

- [54] **SHIELDED COAXIAL CABLE TRANSFORMER**
- [75] Inventor: **Otakar Antonin Horna**, Bethesda, Md.
- [73] Assignee: **Communications Satellite Corporation**, Washington, D.C.
- [22] Filed: **May 19, 1971**
- [21] Appl. No.: **144,940**
- [52] U.S. Cl.....**323/44 R, 323/48, 336/69, 336/84, 336/195**
- [51] Int. Cl.....**H01f 27/36**
- [58] Field of Search....**323/44 R, 48; 336/69, 84, 195**

- 2,273,955 2/1942 Grimditch336/84 X
- 2,724,108 11/1955 Hayes et al336/84 X

Primary Examiner—A. D. Pellinen
Attorney—Surhroe, Rothwell, Mion, Zinn & MacPeak

[57] **ABSTRACT**

A coaxial cable transformer which includes a shielded conductor for reducing primary to secondary winding capacitive coupling which results from the mutual capacitance therebetween. Included between and concentric with inner and outer coaxial conductors, operating as primary and secondary windings, is a selectively grounded shield conductor. This shield conductor is grounded such that there is no instantaneous potential difference between corresponding points on the shield and secondary winding. To reduce indirect primary to secondary capacitive coupling which results from capacitive current between the primary and shield conductors, additional capacitance is included in the transformer circuit.

[56] **References Cited**

UNITED STATES PATENTS

- 1,320,980 11/1919 Bowman.....336/84
- 3,244,960 4/1966 Stevens et al.....336/84 X
- 2,553,324 5/1951 Lord.....336/84 X
- 1,362,138 12/1920 Pratt.....336/84

5 Claims, 10 Drawing Figures

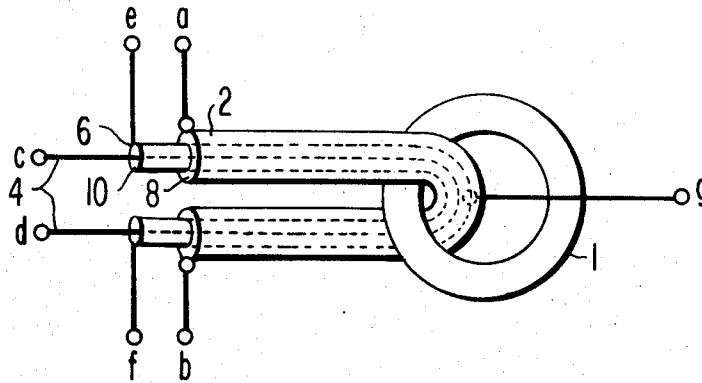

FIG. 1

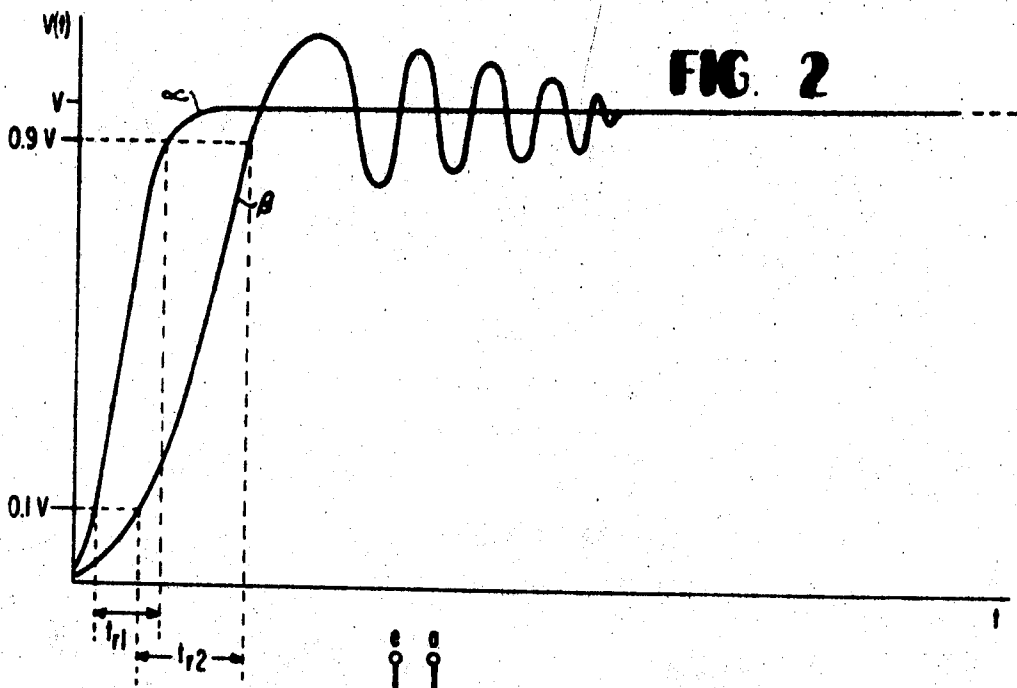
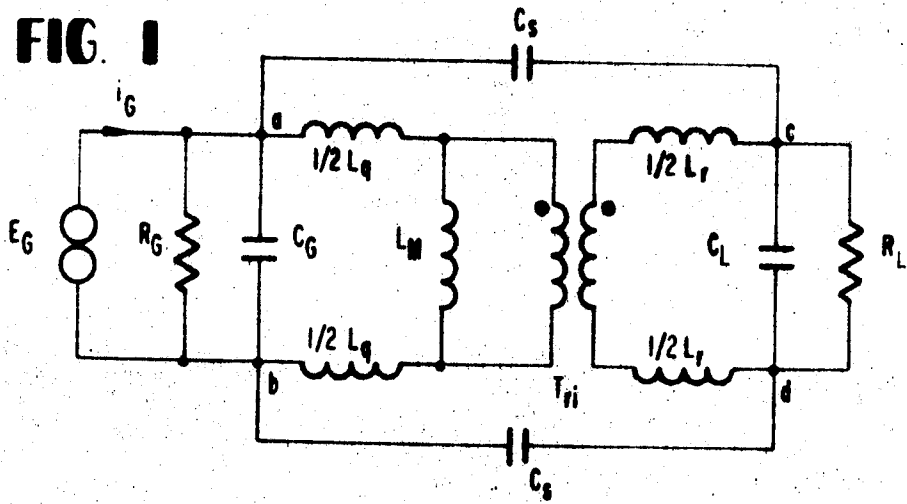

FIG. 3a

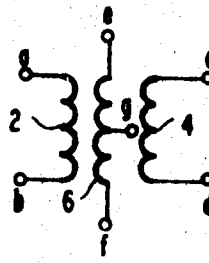
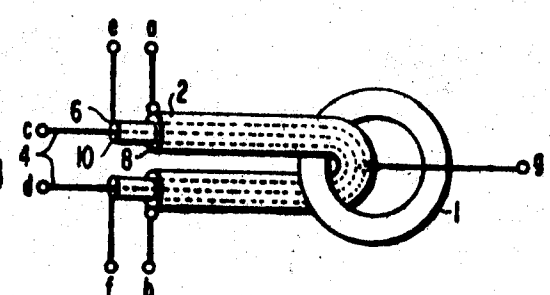

FIG. 3b

INVENTOR
OTAKAR ANTONIN HORNA

BY *Sughrue, Rothwell, Mavin,
Zinn & Macpeak*
ATTORNEYS

PRIOR ART

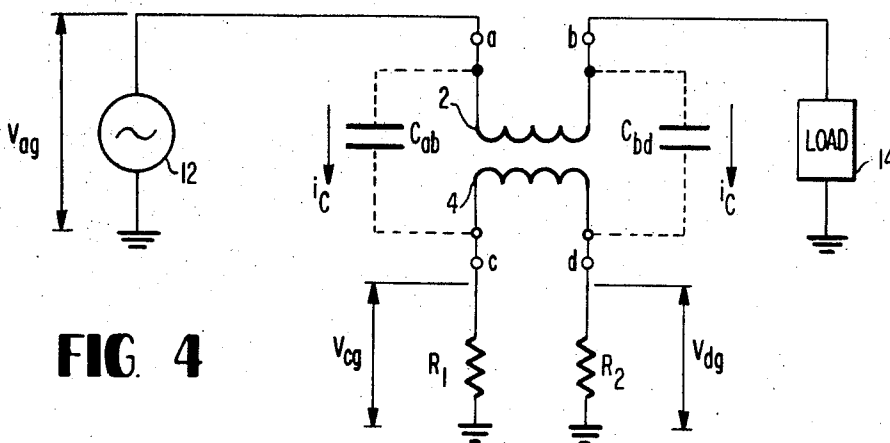

FIG. 4

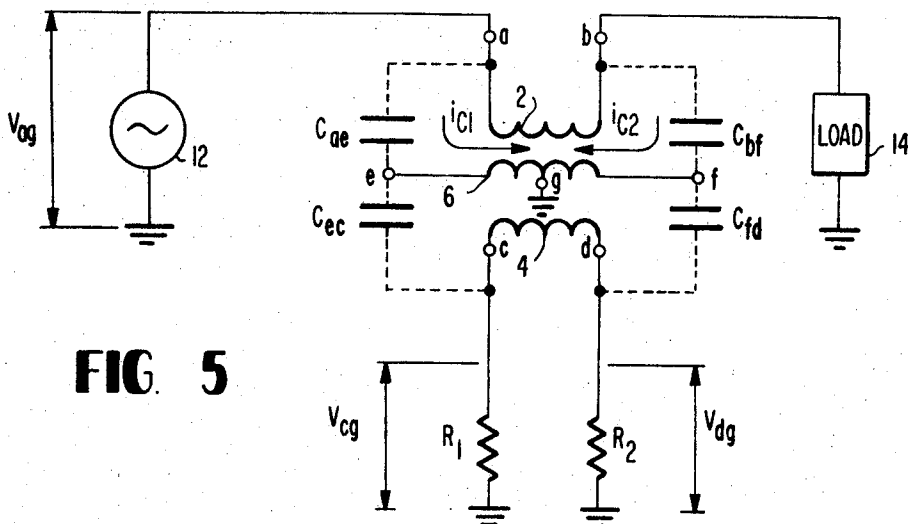

FIG. 5

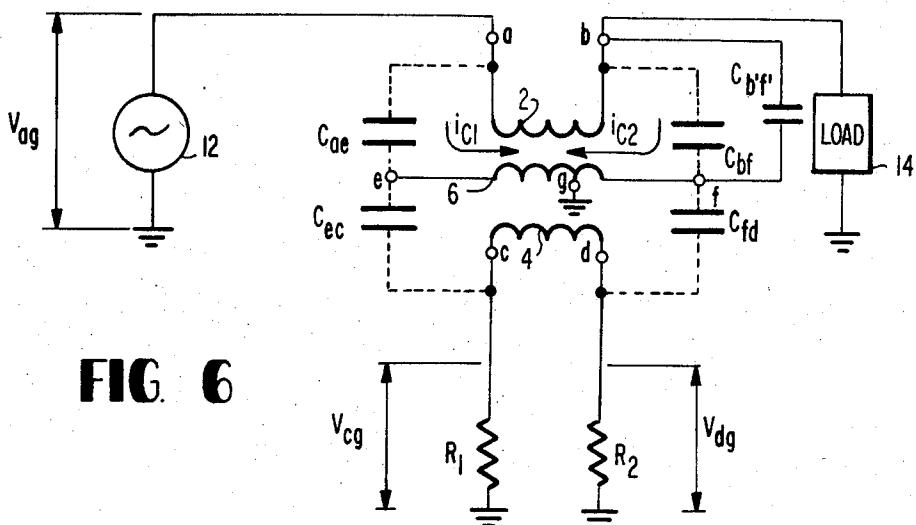
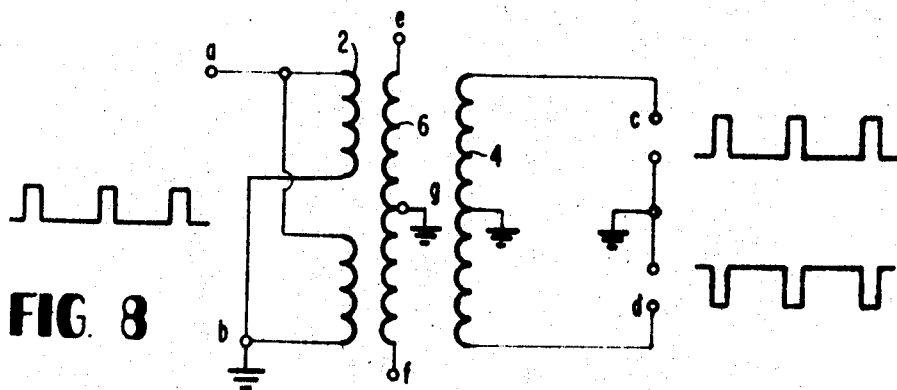
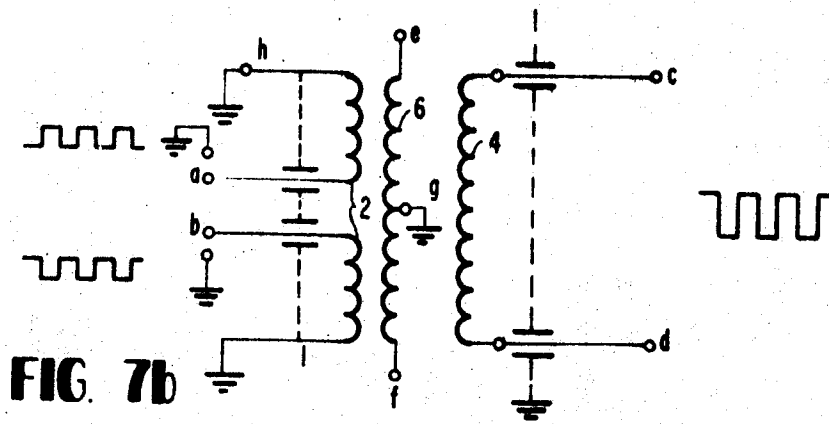
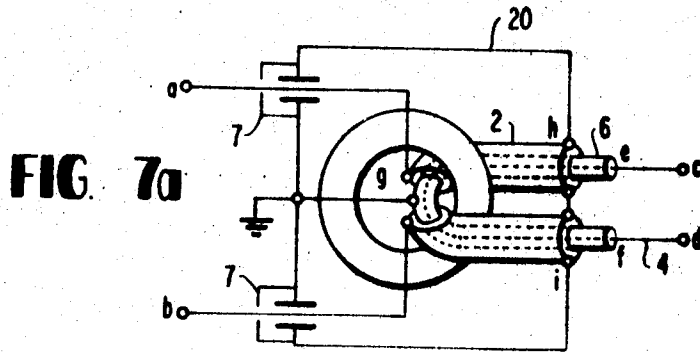

FIG. 6



SHIELDED COAXIAL CABLE TRANSFORMER

BACKGROUND OF THE INVENTION

An important requirement of a high-frequency transformer is the generation of an output signal which corresponds as precisely as possible to the input signal, save for amplitude distinctions resulting from the primary to secondary turns ratio. As a result of stray capacitance and inductance in transformer circuits, output signals often appear distorted. In pulse transformers this distortion appears primarily as a distorted transient response. Transient distortion is seen as a slow rise time along with a ringing or oscillatory transient portion of the output pulse.

In prior transformers with non-concentric windings, the primary cause of transient distortion was stray inductance, stray capacitance being negligible. Development of coaxial cable transformers such as those described in U.S. Pat. No. 3,005,965 and U.S. Pat. No. 3,197,723 resulting from the realization that stray inductance could be appreciably reduced by forming the primary and secondary windings from concentric conductors wound on a suitable core.

Although coaxial cable transformers did indeed reduce stray inductance, the close proximity between the primary and secondary windings gave rise to an appreciable stray capacitance caused by the mutual capacitance between these windings. It is the object of this invention to reduce this capacitive coupling between the primary and secondary windings.

SUMMARY OF THE INVENTION

In accordance with the teaching of this invention transient distortion in coaxial cable transformers is substantially eliminated by reducing the capacitive current which results from the mutual capacitance. Reduction of capacitive current reduces the transient distortion. To reduce capacitive current in the secondary circuit a third conductor is located between first and second concentric conductors, functioning as primary and secondary windings. This third or shield conductor is selectively connected to a reference potential so that corresponding points on the shield and secondary conductors have the same instantaneous high-frequency potential with respect to the reference potential. As a result, no capacitive current, which results from an instantaneous potential difference between adjacent windings, flows through the mutual capacitance between the shield conductor and the secondary.

The shield conductor may give rise to an indirect capacitive coupling between the primary and secondary windings. This coupling results from the instantaneous potential difference between the primary and the shield conductor which causes capacitive current to flow in the shield conductor. This capacitive current can give rise to an induced capacitive current in the secondary. To eliminate this indirect capacitive coupling, the invention provides for the addition of a capacitor between the primary and the shield conductors, when needed, to assure that the resultant potential induced in the secondary in response to the shield conductor's capacitive current is substantially zero.

BRIEF DESCRIPTION OF THE DRAWINGS

FIG. 1 represents an equivalent circuit for a high-frequency transformer,

FIG. 2 represents the transient portions of input and output pluses from a coaxial cable transformer without the improvements of the present invention;

FIG. 3a and 3b illustrate a transformer constructed according to the teaching of this invention,

FIG. 4 illustrates a prior art current transformer coupled to a circuit in which it operates.

FIG. 5 illustrates the circuit of FIG. 4 modified to include the teachings of this invention,

FIG. 6 illustrates the circuit of FIG. 5 further modified to include a capacitor between the primary and shield conductor,

FIGS. 7a and 7b illustrate a transformer constructed according to the teachings of this invention and including a shielding box surrounding substantially all of the transformer, and

FIG. 8 illustrates a transformer embodiment built according to this invention and providing a 1:2 turns ratio.

DETAILED DESCRIPTION OF THE PREFERRED EMBODIMENTS OF THE INVENTION

FIG. 1 represents an equivalent circuit for a high-frequency transformer valid for concentric and non-concentric winding transformers. This equivalent circuit will be used to explain the operation of the invention.

The primary of the transformer of FIG. 1 is coupled at points *a*, *b* to source E_G containing an internal resistance R_G . Source E_G drives the primary winding to induce a potential across the secondary to drive the load R_L . The primary inductance of the circuit given by L_M . The stray inductance on the primary side is given by L_p and is represented by two inductors in series with the inductance L_M . The stray inductance produced on the secondary side of the transformer is given by L_r and is represented in the equivalent circuit by two inductors in series with the winding capacitance C_L . Capacitance C_L represents the capacitance between adjacent turns of the secondary winding, while capacitance C_G represents the capacitance between adjacent turns of the primary. Since each secondary turn in a coaxial cable transformer is shielded by the outer braid, the value of C_L is negligible. The mutual stray capacitance, hereinafter referred to simply as the mutual capacitance, between the primary and secondary windings is distributed along the length of the windings. This distributed capacitance is represented in FIG. 1 by a pair of lumped capacitive elements C_s . In practice $C_s \gg C_G$.

For ease in discussing the theory behind the invention a capacitance C'_s is defined as the equivalent stray capacitance as viewed from the primary side of the transformer where $C'_s = kC_s + C_0$, C_0 representing all the stray capacitance excluding the mutual capacitance. Since the value of C_0 for coaxial cable transformers is negligible compared to the value of kC_s the equivalent stray capacitance is essentially equal to the equivalent mutual capacitance and therefore $C'_s = kC_s$. The value of the constant of proportionality, k , depends on the circuit in which the transformer is used and is primarily dependent upon the transformer turns ratio and the transformer-load interconnection. For example, if points *b* and *d* in FIG. 1 were grounded or more generally connected to the same high frequency reference potential, the equivalent mutual capacitance

would be considerably lower than if points *b* and *c* were coupled to the same high frequency reference potential. Such variations are reflected in the value of *k*. At this point it is noted that the term ground will be used herein to denote any suitable common high frequency reference potential.

It has been determined that as C'_s increases so does the transient distortion.

A better appreciation of the transient distortion may be had by referring to FIG. 2. Waveform α represents the transient portion of an essentially ideal pulse. It is not ideal since it shows a finite rise time. The transient portion of the corresponding output pulse is illustrated by waveform β . The transformer producing this pulse does not contain the elements of this invention. The 10%/90% rise time for the ideal pulse is represented by time t_{r1} . The rise time for the output pulse is given by t_{r2} . The difference between t_{r2} and t_{r1} is the rise time distortion caused by the stray capacitance and inductance. Ringing distortion, shown as the oscillatory portion of waveform β also results from the stray inductance and capacitance.

In transformers with primary and secondary windings not formed from concentric conductors, the relatively large distance between the windings results in a negligible stray capacitance. Therefore, the transient distortion is primarily a function of the stray inductance. This can be seen from the following equation. With stray capacitance neglected the 10%/90% rise time t_r is expressed as:

$$t_r = 2.2 (L_s R_G + R'_L)$$

where: $L_s = L_g + n^2 L_r$; $n^2 L_r$ representing the secondary stray inductance viewed from the primary side of the transformer and $R'_L = n^2 R_L$, the equivalent load resistance.

Thus, when stray capacitance can be neglected, transient distortion can be reduced by decreasing the value of L_s . A popular method of reducing L_s has been to form the primary and secondary windings from a pair of concentric conductors. However, such a transformer configuration causes an appreciable increase in the equivalent capacitance C'_s which counters the advantages realized with lowering L_s . Therefore, it becomes necessary to reduce the effect of this equivalent capacitance C'_s without effecting the value of L_s . This is done by controlling the capacitive current flowing in the secondary which results from C'_s .

Capacitive current in the secondary is controlled by providing a third or shield conductor grounded so that each point on the shield conductor has the same instantaneous high-frequency potential with respect to ground as the corresponding point on the secondary conductor. Under this condition, there is no instantaneous voltage difference between corresponding points on the shield conductor and the secondary winding, thereby preventing a capacitive current between the primary and secondary windings.

FIG. 3a illustrates the basic configuration of a transformer designed in accordance with the teachings of this invention, while FIG. 3b illustrates the FIG. 3a configuration in schematic form. The three conductor coaxial cable is wound around a core 1. The outer conductor 2 which may be used as the primary winding cylindrically encloses and is isolated from the shield

conductor 6 by suitable insulating material 8. Similarly, inner conductor 4 is isolated from the shield conductor 6 by insulating material 10. When outer conductor 2 acts as a primary winding, conductor 4 acts as the secondary. The shield conductor is provided with a terminal *o* for coupling the shield to ground at one point only. The position of terminal *g* on conductor 6 is dependent upon the circuitry coupled across terminals *c*, *d*. In every case, however, terminal *g* is positioned so that corresponding points on the shield and secondary conductors have the same instantaneous high-frequency potential with respect to ground. Therefore, there is no instantaneous potential difference between the shield and the secondary winding and thus no capacitive current flow.

The rules for selectively grounding the shield conductor may better be explained with reference to a circuit which includes a coaxial transformer. FIG. 4 shows a coaxial cable transformer connected as a current transformer. The primary of this transformer is connected to source 12 at terminal *a* and to load 14 at terminal *b*. Terminal *c* of the secondary is connected to ground through a load resistor R_1 while terminal *d* is connected to ground through load resistor R_2 . This transformer is not constructed in accordance with the teaching of this invention.

Capacitance C_{ab} and C_{bd} represent mutual capacitance between primary winding 2 and secondary winding 4. At this point it is noted that common numerals designate equivalent elements in the different figures. If resistance R_1 and R_2 are equal, then in the absence of capacitive current, the voltages across resistances R_1 and R_2 are equal in magnitude, but of opposite instantaneous polarity with respect to ground. If capacitive current, i_c , flows through the mutual capacitances C_{ab} and C_{bd} , the voltages across the resistances have additional components, $i_c R_1$ and $i_c R_2$ which have the same instantaneous polarity with reference to ground causing $|v_{cb}| \neq |v_{db}|$.

The generation of this capacitive current flow between the primary and secondary windings can be explained as follows. In operation, source 12 produces a high-frequency, high potential signal to feed load 14 which may for example be an antenna. As connected in FIG. 4 only a small potential is seen across terminals *a*, *b*. For example, with source 12 generating a 1,000 volt peak voltage it is conceivable to have only a 1 volt drop across the primary winding. With R_1 and R_2 of equal magnitude the 1 volt difference between terminals *c*, *d* (assuming a 1:1 turns ratio) appears as a 0.5 volt drop across each of the resistors. Thus, by way of explanation only and with no intent to so limit the invention, terminal *c* may be at +0.5 volts with respect to ground in which case terminal *d* would be at -0.5 volts with respect to ground. However, terminals *a* and *b* are both at approximately 1,000 volts with respect to ground giving rise to a potential difference between terminals *a* and *c* and *b* and *d*. Of course corresponding potential differences appear between other corresponding points on the primary and secondary windings. This potential difference causes the flow of capacitive current through the mutual capacitance, illustrated as C_{ab} and C_{bd} , causing transient distortion. Thus in our illustrative example, as can be seen from FIG. 4, the voltage drop across resistor R_1 due to the capacitive current i_c is in a

direction that causes it to increase the absolute potential of V_{cg} such that $|V_{cg}| \neq |0.5 + i_c R_1|$ while

- b. a third conductor located concentric with and between said first and second conductors, and
- c. coupling means coupling said third conductor to a reference potential whereby the instantaneous potential at corresponding points on the second and third conductors are equal so that capacitive current flow in said second conductor resulting from the mutual stray capacitance between said first and second conductors is substantially reduced.

FIG. 5 illustrates the circuit of FIG. 4 modified to include a transformer constructed in accordance with the teachings of this invention. This transformer includes a selectively grounded shield conductor 6 surrounding inner conductor 4 which is functioning as a secondary winding. Mutual capacitance exists between the primary winding 2 and the shield conductor 6 as well as between the shield conductor 6 and conductor 4, as illustrated by capacitances C_{ae} , C_{bf} , and C_{ec} , C_{fd} respectively.

To eliminate direct capacitive coupling between the shield conductor 6 and winding 4 there must be no instantaneous voltage difference between the windings. This is accomplished in accordance with the teachings of this invention by selectively locating terminal g on winding 6 and coupling that terminal to ground. With resistors R_1 and R_2 assumed equal and with the winding resistance of conductor 4 distributed uniformly over its length, the midpoint between terminals c and d is at ground potential. Therefore, the terminal g is located at the mid-point of conductor 6 and then connected to ground. Since points e and f are at the same instantaneous potential with respect to ground as points c and d respectively, corresponding points on the shield and secondary conductors have the same instantaneous potential. If resistors R_1 and R_2 are unequal then a point other than the midpoint of conductor 4 is at ground potential. In general, the ground point on conductor 4 for the configuration shown is determined by the ratio of $R_1:R_2$. Therefore the location of terminal g is such that $n_{eg}:n_{gf} = R_1:R_2$, where n_{eg} and n_{gf} represent the number of turns between points e, g and g, f respectively.

Introduction of the shield conductor 4 results in a possible indirect capacitive coupling between the primary and secondary windings. This indirect coupling occurs because of the potential difference between the primary and shield conductors. As a result, capacitive current flows through the mutual capacitance represented in FIG. 5 by capacitives C_{ae} and C_{bf} . This capacitive current in winding 6 induces a voltage which by transformer action appears in secondary winding 4 giving rise to capacitive current in the secondary circuit.

A technique for eliminating this indirect capacitive coupling will now be explained. For the circuit of FIG. 5, terminal g was positioned at the midpoint of conductor 6. Therefore, the voltage across capacitors C_{ae} and C_{bf} is V_{ag} , the source voltage, causing the capacitive currents i_{c1} and i_{c2} to be of the same magnitude but of opposite direction and thus their effect is suppressed. That is, the potential induced in conductor 4 as a result of i_{c1} and i_{c2} are equal in magnitude but opposite in

polarity. When R_1 does not equal R_2 , the positioning of the terminal g on conductor 6 is changed to assure that the instantaneous potential difference at corresponding points on the shield and secondary conductors is zero.

As previously explained, this requirement is met by positioning terminal g such that the ratio $n_{eg}:n_{gf} = R_1:R_2$. In such a case, the capacitive current induced potential in winding 4 does not cancel and a capacitance caused current flows in the secondary circuit.

FIG. 6 represents an embodiment of the invention incorporating means for compensating for this capacitive current. The potential across conductor 4 due to capacitive currents i_{c1} and i_{c2} is given by the expression $V_{ed_{\text{cap}}} \approx n_{eg} i_{c1} - n_{gf} i_{c2}$ where n_{eg} and n_{gf} represent the number of turns between points eg and gf on conductor 6 respectively. Therefore, if $n_{eg} > n_{gf}$, $V_{ed_{\text{cap}}}$ can be reduced by increasing i_{c2} . Since $i_{c2} = C_{bf} dV_{bf}/dt$, i_{c2} can be increased by increasing C_{bf} . In practice this is achieved by increasing the capacitance in the vicinity of the turns n_{gf} .

The added capacitance is illustrated in FIG. 6 by capacitor $C_{b'f'}$. Since conductor 6 protects against direct coupling between the primary and secondary windings, an increase in the capacitance between the primary and shield conductors has no effect upon the secondary circuit.

FIG. 7a illustrates another transformer arrangement which incorporates the teachings of this invention. This embodiment further protects against the introduction of capacitance induced current in the secondary circuit by enclosing the transformer in a shielding box.

FIG. 7b is a schematic drawing of the FIG. 7a transformer configuration. The split primary configuration illustrated in FIG. 7b is conventional. In such transformer configurations equal and opposite pulse trains are applied to the primary side of the transformer to produce output pulses having twice the amplitude as the input pulses. However, in accordance with the teachings of this invention the transformer which includes shield conductor 6 is surrounded by a shielding box 20. Terminals a and b , which receive input signals are connected to primary conductor 2 through the shielding box 20 by means of coaxial connectors shown diagrammatically at 7. Terminals h and i are connected directly to the shielding box 20 by any suitable means. For example, these terminals may be soldered to the box 20. Openings are made in the box to permit passage of conductors 4 and 6. With this configuration terminals a and b are capacitively shielded from terminals c and d , thus further reducing secondary circuit capacitance induced current.

FIG. 8 illustrates the applicability of this invention to a coaxial transformer built with a primary to secondary turns ratio other than 1:1. Again, shield conductor 6 is selectively grounded at one point only so that there is no instantaneous potential difference between corresponding points on conductors 6 and 4. In other respects the configuration of this coaxial cable transformer is conventional.

Although the invention has been described with respect to the preferred embodiment thereof, it is to be understood by those skilled in the art that various modifications can be made in construction and arrangement within the scope of the invention as defined in the appendant claims.

What is claimed:

1. In a transformer circuit including a source and load impedance, a coaxial cable transformer comprising:

a. first and second concentric conductors, said first conductor cylindrically enclosing said second conductor, said first and second conductors functioning as primary and secondary windings, the voltage drop across resistor R_2 due to the capacitive current i_c is in a direction that causes it to decrease the absolute potential of V_{ds} such that $|V_{ds}| = |-0.5 + i_c R_2|$. Thus, $|V_{cs}| = |V_{ds}|$. This voltage imbalance gives rise to transient distortion of the output.

2. The transformer circuit of claim 1 further including applied capacitance between said first and third conductors to substantially eliminate the resultant capacitive current in said third conductor caused by the mutual stray capacitance between said first and third conductors.

3. The transformer circuit of claim 1 further comprising shielding means surrounding said transformer circuit and electrically connected to one end of said first conductor and said reference source, and connector means for permitting electrical connections through said shielding means to said circuit.

4. The transformer circuit of claim 3 further comprising a fourth conductor surrounding said third conductor, one end of said fourth conductor being electrically connected to said shielding means and means for connecting the other ends of said first and fourth conductor to said connector means.

5. In a transformer circuit including a source and

load impedance, a coaxial cable transformer comprising:

a. first and second concentric conductors said first conductor surrounding said second conductor, said first and second conductors functioning as primary and secondary windings,

b. a third conductor located concentric with and between said first and second conductors,

c. coupling means coupling said third conductor to a reference potential to cause the instantaneous potential at corresponding points on the second and third conductors to be equal so that capacitive current flow in said second conductor resulting from the mutual stray capacitance between said first and second conductors is substantially reduced, and

d. wherein the primary winding of said coaxial cable transformer is serially connected between said source and load, further including a second load impedance coupled between one end of the secondary winding of the transformer and said reference potential and a third load impedance coupled between the other end of said secondary winding and said reference potential, said coupling means being connected to said third conductor at a point along the length of said conductor such that the ratio of the number of turns of said third conductor between said one end and said coupling means to the number of turns of said third conductor between said other end and said coupling means equals the ratio of the values of said second load impedance to the said third load impedance.

* * * * *

35

40

45

50

55

60

65