

Recent Advances in Resistance Thermometry Readouts

Rick Walker
Fluke Corporation, Hart Scientific Division
799 East Utah Valley Drive
American Fork, Utah 84003-9775, USA
E-mail: rick.walker@fluke.com
Phone: (801) 763-1600

Recent innovations and technological advances have significantly enhanced the performance and utility of digital resistance thermometry readouts. The readout is an important component of a temperature calibration system, especially when used with a standard platinum resistance thermometer, since the readout contributes to the accuracy, reliability, and efficiency of the system. Accurate digital readouts offering convenient features in a cost-effective solution have been available for many years, particularly since the introduction of the Hart Scientific “Super-Thermometer.” Building on prior work, Fluke-Hart Scientific has continued to improve the technology. This paper discusses some of the recent developments incorporated into a new instrument, which include much improved precision and accuracy; automatic self-calibration of ratio; more stable built-in reference resistors; accurate, traceable sensing current; automatic zero-power resistance and temperature measurements; additional input terminals for thermometers and resistors; and other enhanced features. Results of tests to evaluate the performance of the new readout are presented. The uncertainty evaluation reported in this paper indicates that expanded uncertainties as low as $0.000026\text{ }^{\circ}\text{C}$ at $0.01\text{ }^{\circ}\text{C}$ (a key temperature of the International Temperature Scale of 1990) are achieved. The demonstrated improvements in the resistance thermometry readout are expected to expand capability and increase efficiency in calibration laboratories of all levels.

1 Introduction

Low measurement uncertainty, efficient operations, and reliable results are important objectives in temperature calibration facilities. As a key component of a temperature calibration system, the thermometer readout can either limit or enhance the capability of the laboratory.

In the process of calibrating a resistance temperature sensor, a resistance thermometer readout is needed to measure the resistance of the sensor under test—which may be a platinum resistance thermometer (PRT), standard platinum resistance thermometer (SPRT), or thermistor—while it is held at a known temperature. The temperature standard used for comparison may be a temperature fixed point or a calibrated thermometer, which may also be measured by the thermometer readout. As defined by the International Temperature Scale of 1990 (ITS-90) [1, 2], an SPRT is characterized in terms of $W(T_{90})$, which is the ratio of the resistance at temperature T_{90} and the resistance at the triple point of water temperature ($0.01\text{ }^{\circ}\text{C}$). In practice, $W(T_{90})$ may be taken as the ratio of two resistance ratios, each being the ratio of the SPRT resistance and the fixed resistance of a reference resistor. The reference resistor may be a laboratory-grade standard resistor or high-quality resistor built in to the readout.

Fundamentally, a resistance thermometer readout actually only measures resistance ratio—the ratio of resistance between the temperature sensor and the reference resistor. Resistance can be calculated by multiplying the measured resistance ratio by the known resistance of the reference resistor. Accurate resistance determination requires that both the resistance ratio and the reference resistance have low uncertainties. In some applications, such as calibrating a thermistor, accuracy of resistance is important, and uncertainty as low as 6 ppm or lower may be required. In other cases, such as measuring temperature with an SPRT or calibrating an SPRT, resistance ratio accuracy and stability of the reference resistor are more important than resistance accuracy, and uncertainty as low as 0.2 ppm or better is often required.

There are several characteristics of the resistance thermometer readout that affect the accuracy of resistance ratio measurements. Electrical noise in internal components causes random errors or measurement noise. Nonlinearity in electrical components and circuits causes systematic measurement error. Short-term instability of the reference resistor causes errors when determining $W(T_{90})$ because the two resistance ratio measurements are taken at different times. Errors present in the system or process used to calibrate the readout directly transfer to the readout. All these factors must be controlled and limited to guarantee accurate, low-uncertainty resistance ratio measurements.

Accuracy of resistance determinations is affected not only by the factors just listed, it also depends on the reference resistor. The reference resistor must be calibrated with low uncertainty and must remain constant over time and as environmental conditions, including temperature, change.

As mentioned, process efficiency may be as important, and in some cases even more important, than uncertainty. Characteristics of the readout that can enhance process efficiency are measurement speed, number of input connections, and a well-designed user interface.



Figure 1. The newest and most advanced digital thermometer readout: The Fluke-Hart Scientific Model 1595A “Super-Thermometer.”

Work at Fluke-Hart Scientific has been ongoing to develop more advanced digital resistance thermometry readouts that offer ever better accuracy, convenience, and efficiency. In 1994, Hart Scientific developed the 1575 “Super-Thermometer,” the first digital resistance thermometer readout of its kind that provided very good accuracy (4 ppm for resistance ratio) combined with a multitude of convenience and efficiency-related features, at lower cost than previous solutions. The most recent in this family of instruments is the 1595A “Super-Thermometer” (see Figure 1). It incorporates the latest advances in technology and design and achieves resistance ratio measurement uncertainties as low as 0.1 ppm. It also provides many features that support quality and efficiency in a temperature calibration laboratory, such as automatic ratio self-calibration, additional input connections, faster measurement speed, and automated zero-power measurement. The remainder of the paper will describe some of the recent advances incorporated in the new resistance thermometer readout.

2 Reduced Measurement Noise

The new resistance thermometer readout exhibits measurement noise that is five to ten times less than that of the previous generation. This was achieved through improvements in the design of the amplifier, use of multiple analog-to-digital converters operating in parallel, and on/off control of the power supply. (Several of the innovations have been filed for patents.)

A simplified schematic diagram of the measurement circuit used in the original thermometer readout is shown in Figure 2 [3]. A common direct current flows through the sensor (R_X) and reference resistor (R_S). A single analog-to-digital converter (ADC) samples the voltage from each resistor through a switch and amplifier. The switch alternates to connect the input of the amplifier to the sensor and reference resistor in turn. Samples from the two resistances are divided to produce a measurement of the voltage ratio, and hence the resistance ratio. In the original thermometer readout, measurement noise came primarily from the ADC, with some contribution from the amplifier and current source as well.

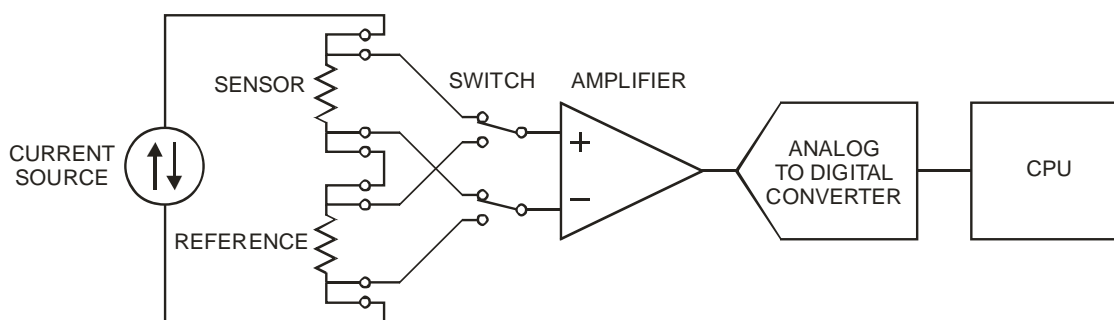

Figure 2. Simplified schematic diagram of the original digital thermometer readout.

In the new resistance thermometer readout, significant improvements in the amplifier were made to reduce noise. Also, a more advanced circuit architecture was developed, one that uses multiple ADCs [4]. A simplified schematic diagram of the new design is shown in Figure 3. The measurement circuit has two similar sections, each with its own amplifier and pair of ADCs. While one

section is sampling the sensor with two ADCs, the other is sampling the reference resistor with the other two ADCs. When the switch reverses, each samples the other resistance.

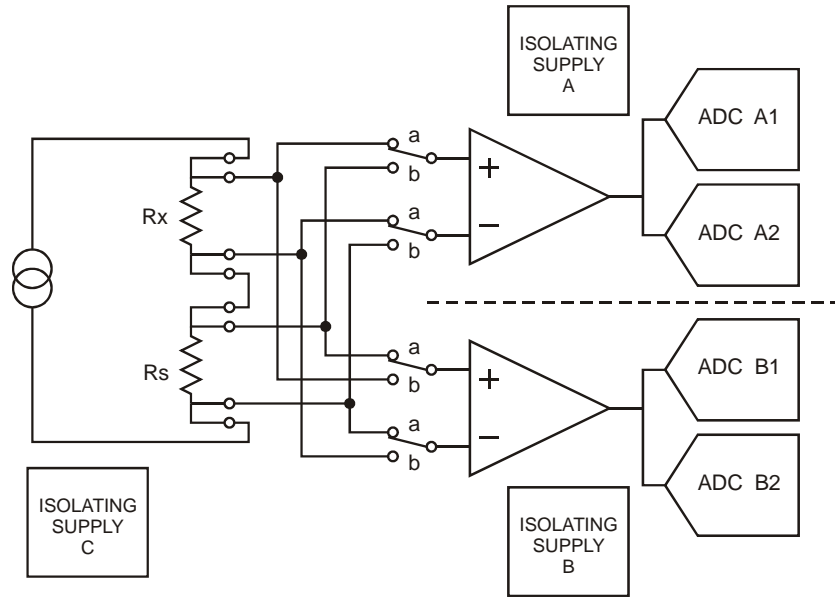

Figure 3. Simplified schematic diagram of the new resistance thermometer readout.

The design reduces noise in several ways. Noise from the current source is canceled because both resistances are sampled at the same time. The higher-quality amplifiers and ADCs generate less noise. The impact of noise from all sources is reduced by averaging many ADC samples.

The measurement circuits require three isolated power-supplies that are prone to generating electrical noise. To prevent power supply noise from interfering with the measurements, the power supplies are switched off during ADC conversions. During that time the circuits draw quiet power from charged capacitors [5].

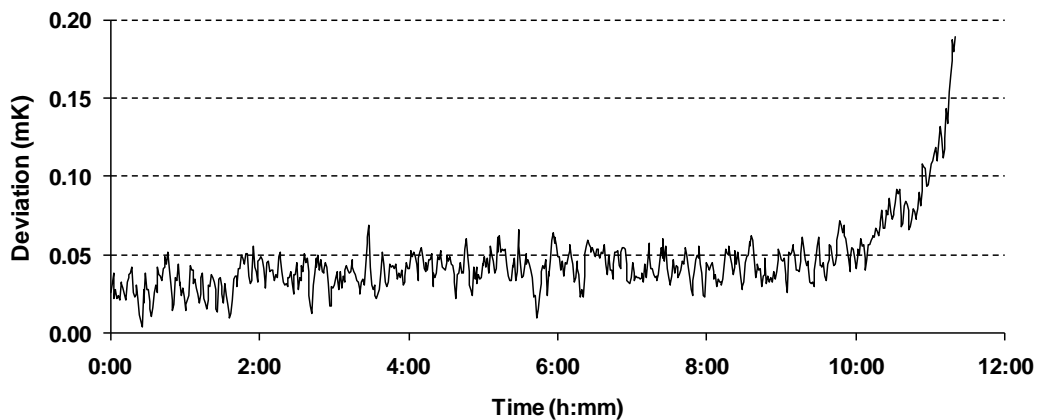

Figure 4. Measurements of a mercury fixed point cell using the resistance thermometer readout.

The performance of the new measurement circuit with regard to noise is demonstrated in Figure 4. This shows the results of measuring the melting temperature of a mercury fixed-point cell over several hours using the 1595A “Super-Thermometer.” The temperature sensor was a 25.5 Ω SPRT. Its resistance was measured against a 25 Ω reference resistor using 1 mA sensing current. The readout was set to produce a measurement of resistance ratio every 10 seconds. The digital filter in the readout was set to apply a moving average on 20 readings. The standard deviation of the recorded measurements during the stable part of the plateau was 0.009 mK.

3 Improved Accuracy

The nominal resistance ratio accuracy of the new resistance thermometer readout is about five times better than that of the previous generation. This was achieved by careful design of the measurement circuits (including the amplifier), use of newer ADCs, attention to possible sources of electrical interference, and correction for residual nonlinearity.

To evaluate resistance ratio accuracy, the new resistance thermometer readout was tested using an Aeonz/Industrial Research RBC400 Resistance Bridge Calibrator. This device contains a set of precision resistors that can be switched in various series and parallel configurations, producing many different resistances. After measuring the resistances with a resistance thermometer readout, analysis of the data results in a determination of the measurement errors at each of the resistances tested [6].

The test of the new resistance thermometer readout produced measurements at 35 different resistance ratios (against a 100 Ω reference resistor). Figure 5 plots the observed relative errors at each test point resistance ratio. The standard deviation of the relative errors is 0.044 ppm. Errors tend to be smallest near a ratio of 1.

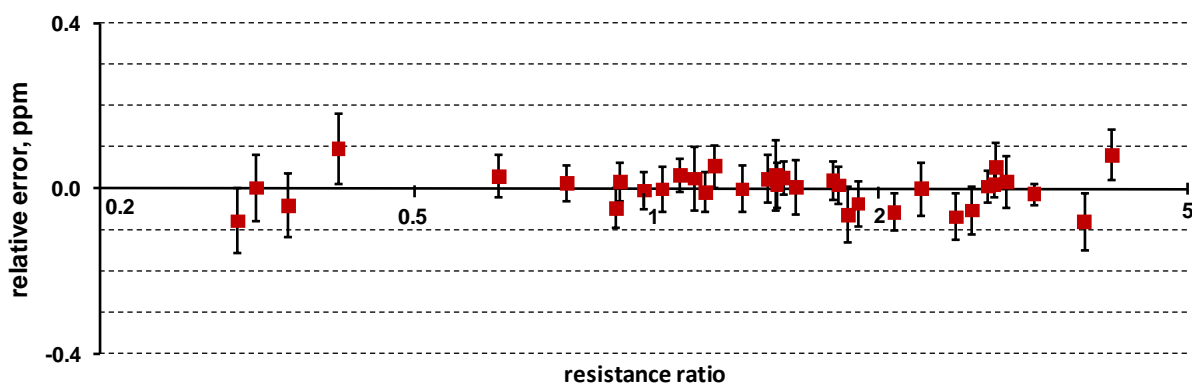

Figure 5. Relative error vs. resistance ratio with the new resistance thermometer readout.

4 Ratio Self-Calibration

One issue that has always been a problem with the most accurate resistance thermometer readouts and bridges is how to calibrate them. It typically requires expensive equipment, special expertise, and lots of time. As a result, many instruments go untested for long periods. One of the more significant advances that has been made in the development of the new resistance ther-

meter readout is the capability to self-calibrate its resistance ratio accuracy [7]. Rather than requiring external equipment, the Ratio Self-Calibration method uses only built-in resistors and switches.

Measurement nonlinearity in a digital thermometer readout arises primarily from nonlinearity of the ADCs and, to a lesser degree, nonlinearity of the amplifiers and electrical leakage currents between circuit components. The Ratio Self-Calibration method was found to be very effective at quantifying measurement error due to these nonlinearities.

Ratio Self-Calibration makes use of a built-in resistance voltage divider comprised of two resistors having resistances R_1 and R_2 , as shown in Figure 6. A Ratio Self-Calibration test has two steps. In the first step, the R_X source connects across R_1 and the R_S source connects across both resistors. The resulting resistance ratio, $r_a = R_1 / (R_1 + R_2)$, is measured. In the second step, the R_X connections are changed so that the opposite resistance ratio, $r_b = R_2 / (R_1 + R_2)$, is measured. When the two measurements are added, the result would be exactly 1 of there were no measurement error. This type of test is called a ratio-sum test.

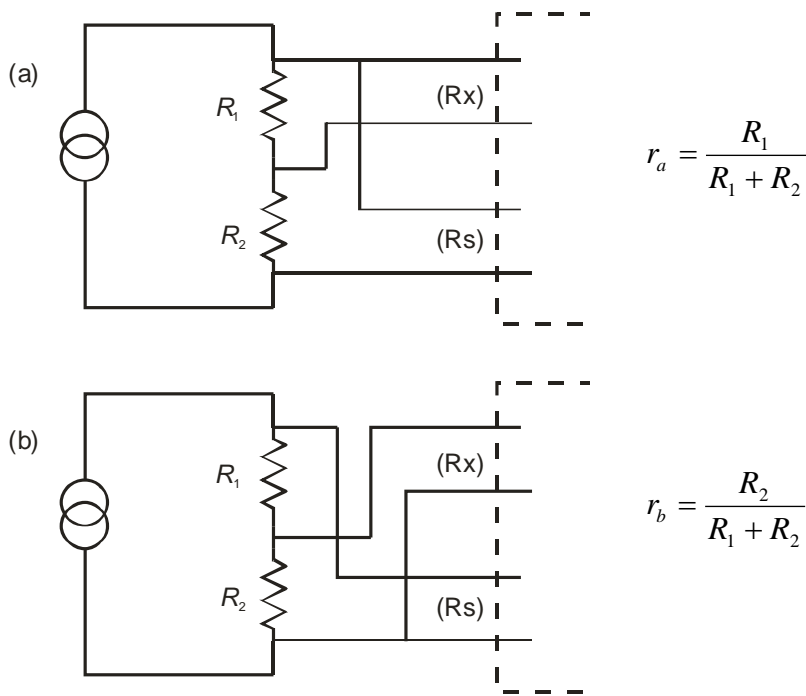

Figure 6. Schematic diagram showing connections for a Ratio Self-Calibration test.

Because the nonlinearity of the ADC and amplifier can vary depending on the magnitude of the voltage signal, it is necessary to perform ratio-sum tests at several different levels of amplifier gain. The ratio-sum test is also performed with two different resistance voltage dividers, one having nearly equal resistances and the other having unequal resistances of a 3 to 1 ratio. Switching among the various connections and programming of the amplifier gain is handled automatically by the central processor using electronically controlled switches and relays.

Two additional types of tests can be performed automatically to further add confidence or help diagnose a failure if it occurs. One is a zero test. In this test, the Rx input of the measurement circuit is shorted, and the measured resistance ratio is ideally exactly 0. The second test is a complement test, where in the first step the R_X and R_S inputs are connected to resistances that are nearly equal, producing a resistance ratio near 1. In the second step the resistances are swapped. The second resistance ratio should be the reciprocal of the first, and their product ideally would be exactly 1. In total, Ratio Self-Calibration contains eight different tests.

The resistance thermometer readout tested previously using the RBC400 was also tested using the Ratio Self-Calibration method. The results for each of the eight tests are given in Table 1. The observed errors are similar in magnitude to those of the RBC400 test.

Table 1. Results of Ratio Self-Calibration tests.

	mean (a)	mean (b)	combined	error (10^{-6})
1. Zero	-0.00000003	-0.00000003	-0.00000003	-0.03
2. Complement	0.99984357	1.00015645	1.00000000	0.00
3. Equal ratio-sum, 100%	0.49996091	0.50003913	1.00000004	0.04
4. Equal ratio-sum, 90%	0.49996094	0.50003912	1.00000006	0.06
5. Equal ratio-sum, 75%	0.49996088	0.50003914	1.00000002	0.02
6. Equal ratio-sum, 60%	0.49996091	0.50003906	0.99999997	-0.03
7. Equal ratio-sum, 50%	0.49996084	0.50003907	0.99999991	-0.09
8. Unequal ratio-sum	0.75003171	0.24996828	0.99999999	-0.01

5 Improved Resistor Stability

Effort was made to improve the stability of the internal reference resistors. Better resistor stability improves the accuracy of resistance measurements when calibrating PRTs and thermistors. If the internal resistors are stable enough, they can also be used for SPRT calibration, instead of the expensive and space-consuming standard resistor systems that have typically been used.

Very stable, low-TCR metal foil resistors were selected for the new resistance thermometer readout. A 25 Ω resistor was added, in addition to the 1 Ω , 10 Ω , 100 Ω , and 10 k Ω internal resistors built in to earlier thermometer readouts. The 25 Ω resistor is the optimal choice when using 25.5 Ω SPRTs.

The resistors are embedded in a metal block that is temperature controlled using a thermistor sensor and thermo-electric heating device that heats or cools the resistor block as needed. Thus the temperature of the resistors is controlled at a constant temperature, typically within $\pm 0.01^\circ\text{C}$, even as ambient temperature changes.

The long-term stability of the resistors is typically 5 ppm or better and can be as low as 2 ppm depending on laboratory conditions. The short-term stability is much better, due to the tight temperature control. Most of the resistors can hold their resistances to within about 0.04 ppm over a several-hour period.

As a demonstration of the stability of the internal reference resistors, refer again to Figure 4. The measurements of the mercury temperature were made using an SPRT and the internal 25 Ω reference resistor. Over the several hours of the test, any drift in the resistance of the internal reference resistor is imperceptible.

6 Accurate and Traceable Sensing Current

An accurate current source is important when considering errors caused by self-heating of the sensor as its resistance is measured. Self-heating cannot be avoided, but its effect can be mostly corrected if the magnitude of the current is accurately known and can be controlled. Special attention was given to the design of the current source in the new resistance thermometer readout, and procedures were implemented to calibrate and test the current source and establish traceability to voltage and resistance standards. As a result, uncertainty in the magnitude of the sensing current is typically less than 0.2 % at 1 mA. When applying self-heating corrections, the current uncertainty translates to a temperature uncertainty component ($k = 1$) that is typically less than 0.007 mK.

7 Measurement Speed

One advantage offered by the measurement circuit architecture used in the digital thermometer readout, as opposed to other designs, particularly those of traditional resistance bridges, is measurement speed. This can be defined as the time required to display the first accurate measurement after a sensor is connected (or the input channel is switched) and the measurement is started. Measurement speed contributes to process efficiency, especially when a large number of sensors are being calibrated. In some cases it can also result in lower uncertainties by reducing the time between the measurement of the sensor under test and that of the temperature reference.

Resistance bridges typically balance in 10 to 30 seconds. In contrast, the original digital thermometer produced measurements within two seconds. With an improved design based on modern ADCs, the new resistance thermometer readout is capable of measuring in one second, even while scanning among many input channels.

8 Input Connections

Traditional resistance bridges and other early readouts usually had only one set of input connections for the measured sensor, and one set of connections for the external reference resistor. Hart Scientific's original digital thermometer readout contained built-in reference resistors, which frees up an input for a second sensor, allowing simultaneous connection of the sensor under test and the reference thermometer. Modern calibration procedures may require additional inputs, such as one dedicated for a check standard. Extra inputs can allow connection of a reference thermometer while one or more external reference resistors are also connected. The latest

resistance thermometer readout is constructed with four sensor inputs and two dedicated reference resistor inputs (at the rear) for maximum flexibility, convenience, and efficiency. For instance, it is possible to have two test sensors, a check standard, a reference thermometer, and two reference resistors all connected at once.

The spring-loaded connection terminals are designed for quick connect and disconnect, again assisting process efficiency. The oblique orientation and the arrangement of terminals add to their convenience [8]. The terminals are made of gold-plated tellurium copper having a low thermoelectric coefficient, which helps control measurement noise in drafty conditions.

9 Other Features

The new resistance thermometer readout incorporates several other features that help boost process efficiency. These include automatic zero-power measurement, standby current, and statistical calculations.

To correct for self-heating in the sensor and achieve lowest uncertainties, measurements may be performed at two levels of sensing current, allowing extrapolation of the measurement to zero power. Whereas in the past the self-heating measurements and zero-power calculations would be done manually or under computer control, the new resistance thermometer readout can do it all automatically. After the user selects the currents to use and the timing settings, the readout makes the measurements and calculates the zero-power results by itself.

During a calibration process, time is sometimes wasted waiting for the self-heating in sensors to stabilize, especially when multiple sensors and reference thermometers are to be measured. The new resistance thermometer readout avoids unnecessary settling delays by providing independent standby or “keep-warm” currents for each input channel. While one sensor is being measured, standby currents applied to sensors connected to other inputs maintain constant and precise self-heating and keep the sensors ready for quick measurement.

The resistance thermometer readout displays a variety of useful statistical quantities related to the measurement, such as mean, standard deviation, minimum, maximum, and spread. It also automatically calculates and displays the standard error of the mean. This indication provides assurance that the uncertainty in the mean due to measurement noise is adequately low.

10 Uncertainty Analysis and Conclusion

Uncertainty in the measurement of an SPRT has several components that depend on the thermometer readout. The most notable of these linearity, measurement noise, and reference resistor stability, and sensing current uncertainty. Table 2 lists typical uncertainties for the new resistance thermometer readout using a 25.5 Ω SPRT. Uncertainties as low as 0.026 mK at the triple point of water are achievable.

The results demonstrate that the advances incorporated into the design of the new resistance thermometer readout lead to extremely low uncertainties. At the same time, the features and

characteristics of the new resistance thermometer readout offer greater convenience and support process efficiency.

Table 2. Uncertainties of the new resistance thermometer readout measuring resistance ratio of an SPRT at several fixed-point temperatures.

Component	-189 °C	0.01 °C	157 °C	420 °C
Linearity (ppm)	0.12	0.03	0.06	0.08
Measurement noise (ppm)	0.14	0.04	0.05	0.06
Sensing current (ppm)	0.002	0.010	0.015	0.025
Combined standard uncertainty (ppm)	0.184	0.051	0.080	0.103
Expanded ($k = 2$) uncertainty (ppm)	0.369	0.102	0.159	0.206
Uncertainty in W_{T90}	7.97×10^{-8}	1.02×10^{-7}	2.56×10^{-7}	5.29×10^{-7}
Equivalent temperature uncertainty (mK)	0.018	0.026	0.067	0.151
Uncertainty with internal resistor (mK)	0.018	0.027	0.070	0.154

Conditions: 25.5 Ω SPRT; 25 Ω external reference resistor, uncertainty not included; 1 mA sensing current; 2.5 min. measurement time; fixed-point temperature uncertainty not included.

References

1. Preston-Thomas H., “The International Temperature Scale of 1990”, *Metrologia* 27, 3 (1990).
2. Mangum B. W., Furakawa G. T., *NIST Technical Note 1265, Guidelines for Realizing the International Temperature Scale of 1990* (1990).
3. Walker R., “Precision Temperature Readout Using Solid-State Electronics”, *Proceedings of the 1996 Workshop and Symposium, Vol. 2*, p. 809, National Conference of Standards Laboratories.
4. United States patent application 12/497318: “Resistance Bridge Architecture and Method.”
5. United States patent application 12/477791: “System and Method for Using Stored Electrical Energy to Quiet Power Sensitive Measurement Circuits.”
6. White D. R., “A Method for Calibrating Resistance Thermometry Bridges”, *Proceedings of TEMPMEKO '96*, p. 129.
7. United States patent application 12/497296: “Internal self-check resistance bridge and method.”
8. United States design patent D613251: “Instrument Design Using Oblique Mounted Terminal Posts”.