

#### 4.1 Comment

Measuring instruments with digital readouts have the advantages of high resolution and of not requiring visual interpolation of an analog scale. Perhaps even more important today is their ability to pass data to a computer thus avoiding the possibility of human error in the reading and recording of measurement data and eliminating the time it takes for a human to perform these functions. Moreover, once the data is passed on to a computer, it can be used to perform the overall task for which the measurement was made: sorting components, controlling processes, characterizing networks, studying materials, calibrating impedance standards etc. The human operator now gets the final output, what he really wants, and need not be concerned with the result of any single measurement. Measuring instruments have become the interface between the physical world and the computer world, a critical part of the "information age".

#### 4.2 Digital DC Meters

The first instruments with digital readouts were counters, timers and frequency meters that were completely digital in nature and needed no analog-to-digital conversion. Early digital voltmeters compared the unknown voltage to the output of a precision D/A converter or used integrating methods such as voltage-to-frequency converters or pulse-width modulators. Many other A/D techniques quickly became available, but the most important for precision meters of all sorts was the dual-slope or up-down integrator which was described in a 1966 paper by H. Schmidt<sup>1</sup> and is related to a modification of the integrating pulse-width modulator patented by R. W. Gilbert<sup>2</sup> in 1963. This circuit not only converts an analog voltage to a digital number, it also

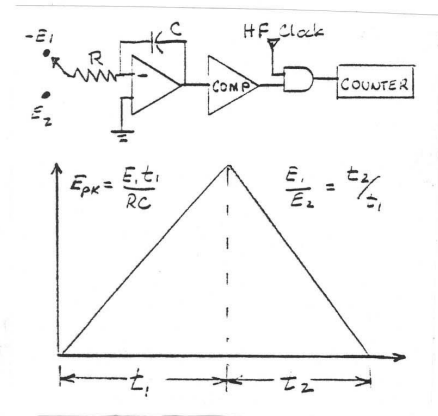

4-1 Dual-Slope Integrator



4-2 Digital Ohmmeter  
ESI Type 1700 1977

makes a division, the ratio of two voltages, the one that drives the integrator voltage up and the other, of the opposite sign, that drives it down, see figure 4-1. The up slope occurs for a fixed time interval, a fixed number of pulses,  $N_1$ , of a HF clock. The time of down slope depends on the down voltage and is measured as a count  $N_2$  that stops when the output voltage returns to zero. Thus the ratio of the two voltages is the reciprocal of the ratio of the two time intervals or the two counts. In a dc voltmeter this ratio is that of the unknown voltage to a voltage standard.

Digital meters of all types quickly became very popular and could be very precise because the accuracy was not limited to the resolution of an analog meter scale. Many digital multimeters (DMMs, digital voltmeters) that also measure current and resistance) measure resistance by connecting the DUT to a precision current source and measuring the voltage across it. On the other hand most of them take the ratio of the voltage across the DUT to the current through it, the current being measured as the voltage across a standard resistor in series with the DUT. This has the advantage that their accuracy is not dependent on the stability of a current source. Digital milliohmmeters and micro-ohmmeters apply more current to very low-valued resistors than do DMMs and thus get better accuracy at these values. For example the ESI Model 1700 (figure 4-2) which, with the SP 3779 plug-in unit, applies 1 ampere and can resolve  $0.1 \mu\Omega$ .

Digital resistance limit bridges can be used with preset, internal or external, digital limit comparators for automatic sorting to percent tolerances. DMMs that read resistance, not percent deviation, require limits expressed in resistance values rather than percent. Later, "smart" meters calculated the percent deviation from the resistance reading and a nominal resistance value that had been entered into memory.

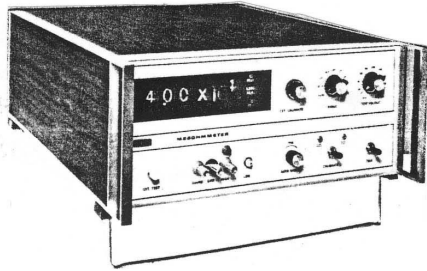

**4-3 Digital Megohmmeter  
Beckman Type L-9 c1982**

Analog-to-digital methods were applied to megohmmeters such as the Beckman Model L-9 (figure 4-3), but most applications of megohmmeters, such as leakage resistance measurements, require only low ac curacy and thus high-resolution digital readouts are of little advantage except for logging data or setting limits. However, measuring precision, high-valued resistors requires the best possible accuracy and the Guildline Teraohmmeter, type 9520 (figure 4-4) that was based on a design by H. Tsao<sup>3</sup> of NRC was by far the most accurate, more accurate than most megohm bridges. It measured 100 MΩ to .035%, 1 TΩ to .2% and 1 EΩ (10<sup>15</sup> ohm) to 1%. It too uses an integrator but the integrator resistance is the resistance being measured and the capacitance is an air capacitor to keep the leakage current negligible. A revised version of this instrument is still one of the most accurate of this type.

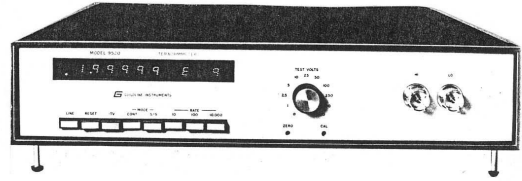

**4-4 Digital Teraohmmeter  
Guildline Model 9520 c1970**

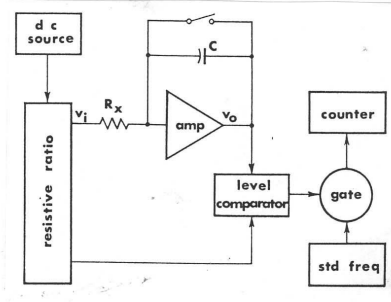

### 4.3 Ac Digital Meters

Digital ac impedance meters also use the dual-slope integrator to make the voltage/current division but they required phase-sensitive detectors to supply the correct dc voltages. Examples of meters that measured capacitance were the early (1960) Electro-Instruments series CD Digital Capacitance Meter (figure 4-5) and the Micro Instruments 5300 series Capacitance Tester (c1965)

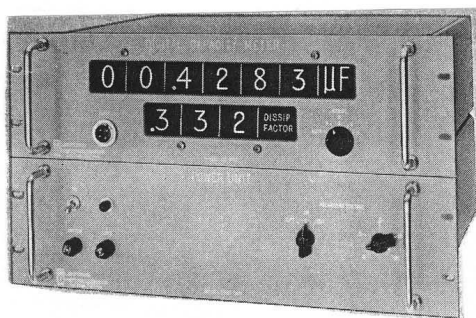

**4-5 Digital Capacity Meter  
Electro-Instr. Model CD 1960**

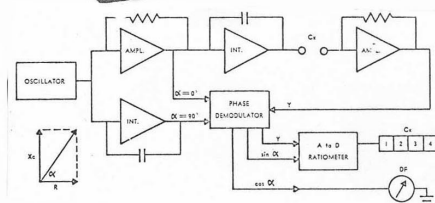
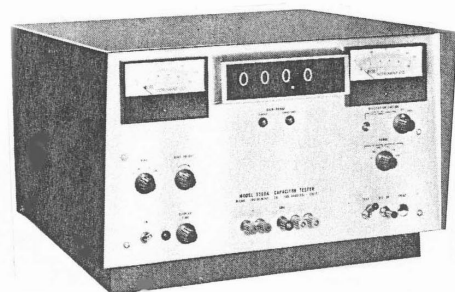

**4-6 Capacitance Tester  
Micro Instr. 5300A c1965**

(figure 4-6). Digital impedance meters that measured R, L and C were the ESI Model 251, figure 4-7 and the GR 1685, figure 4-8. These instruments had accuracies of 0.25% or so, some to 0.1%, and they competed well with general-purpose bridges. They had two disadvantages. Having no memory, they could only make one division at a time and thus they could measure and display the main component (R, L or C) or the phase component (D or Q), but not both simultaneously. Also their phase accuracy, particularly accuracy of low D measurements, was limited by the ability of getting a precise 90° phase shift for the necessary phase reference signal.

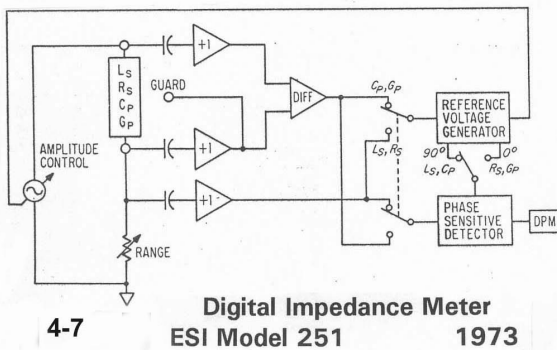
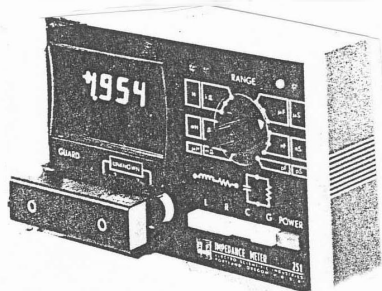

**4-8 Digital Impedance Meter  
GR Type 1685-A 1973**

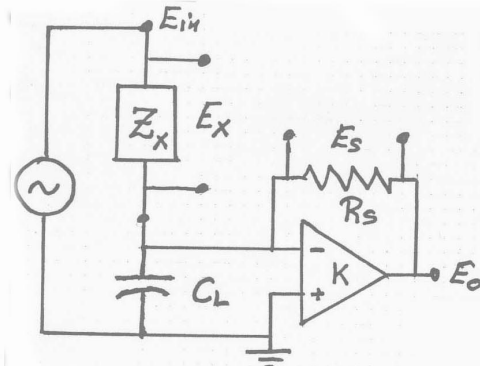

**4-9 Front - End Circuit**

The GR 1685 and most other meters used an inverter amplifier and standard resistor as the current detector, as shown in figure 4-9. The amplifier brought the junction of  $Z_x$  and  $R_s$  near ground potential so that there was little current through a loading capacitance,  $C_L$ , thus keeping the error small. The error due to  $C_L$  is  $\omega C_L R_s / K$  where  $K$  is the open-loop at the test frequency. While this scheme is usually adequate at lower frequencies for reasonable loading capacitances, it becomes



**4-10 1 MHz LCR Meter  
HP Model 4271 1974**

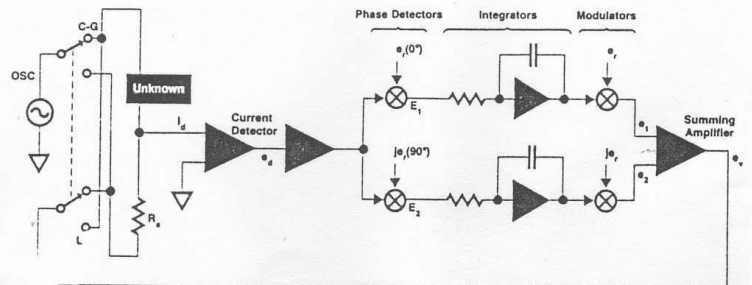

poorer at higher frequencies where  $K$  is greatly decreased and the loading admittance of stray capacitance increased. HP (Yokagawa-Hewlett Packard or YHP) developed a integrating-modulating scheme for their type 4271 1 MHz meter<sup>4</sup> in which this junction point was brought to ground by an automatic "bridge" balance that had very high effective loop gain (figure 4-10). The voltages across the unknown and the standard were still measured by a dual-slope converter as in other meters, the "bridge" only improved the guarding

capability. HP used this microprocessor-based Z meters. This instrument had two dual-slope detectors so that it could indicate C and D, C and G or L and R simultaneously.

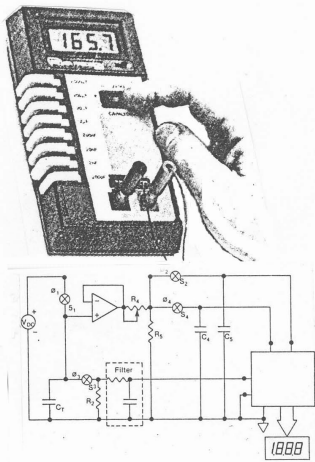

4-11 Hand-held Capacitance Meter  
Data Precision Model 938 1979

Another class of digital meters was that of small, hand-held capacitance meters. While these were very useful and inexpensive, many of them, such as type 938 by Data Precision (1979) (figure 4-11), used RC charge-discharge methods rather than sinusoidal signals so that their measurements of frequency-dependent capacitors, such as those with electrolytic or high-K ceramic dielectrics, did not agree with those made at the industry-specified test frequencies. Later other hand-held meters, such as the AVO/Biddle B183, did use standard test frequencies and measured inductance and resistance as well as capacitance.

#### 4.4 Automatic AC Bridges

Several attempts were made to mechanically automate the balancing process so that the accuracy of bridges could be combined with the speed and ease of use of a meter. In 1951 Graham<sup>5</sup> described a complex inductance bridge using phase-sensitive detectors and servo motors that drove a variable resistor and an inductor. Frischman<sup>6</sup> automated a GR 716-C Schering bridge for dielectric measurements in 1960 by driving its variable capacitors in a similar manner. Barnes also mechanically automated a GR 1611 for high capacitance measurements, their type 61, see figure 4-12. Rohde & Schwarz also had a motor-driven bridge "for heavy current capacitors", their type KVZA (figure 4-13). Simmonds Aerocessories, Inc. made a mechanically automated bridge of their own design (model 387011) for testing capacitive fuel gages.

An interesting development was the "semi-automatic" HP 4260A Universal Bridge, developed by a team at YHP under Yoshimoto<sup>7</sup>, see figure 4-14. The main bridge adjustment, the R, L or C balance, was manually made but the secondary (D or Q) balance was an electrically variable component, the

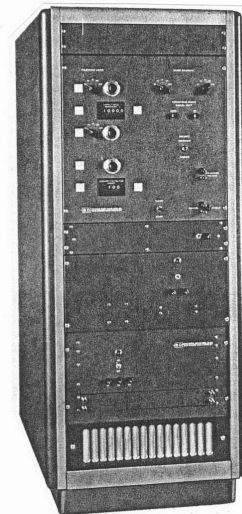

4-12 Automatic High Capacitance  
Test Set Type 61  
Barnes Dev. Co. 1961

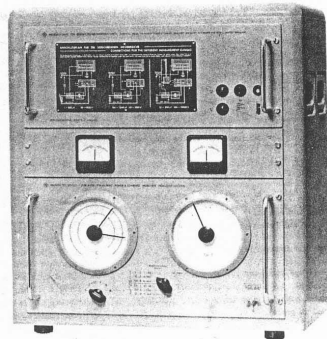

4-13 Automatic Test Bridge  
R&S Type KVZA 1960

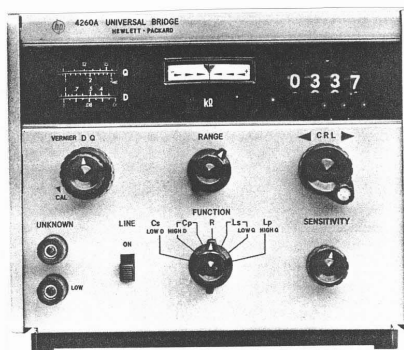

4-14 Universal Bridge  
HP Model 4260A 1966

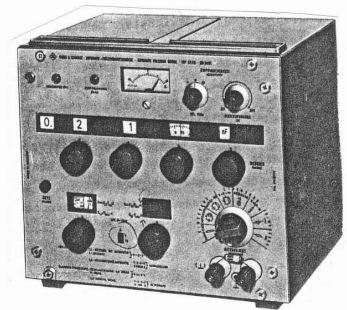

4-15 Automatic Precision Bridge  
R&S Type RLCB 1969

ac resistance of diodes driven by the phase-detected bridge output. This made the main balance easier, particularly when there is interaction between the balances, the so-called "sliding null" of most RLC bridges had when measuring low-Q inductors. The D or Q value was not determined automatically, but if these values were desired, a manually-balanced rheostat could be substituted for the diodes and that balance could then be made quickly. Rohde & Schwarz had a somewhat similar unit, the "RLCB" bridge, designed by Schmidt and Kolbe<sup>8</sup>, that also used diodes as the electrically variable bridge component, see figure 4-15. A patent by Whatley<sup>9</sup> filed in 1965 had proposed using photo diodes. Wayne-Kerr made a "Push-Button" bridge, the B641, whose digital adjustment as made sequentially by manual buttons guided by a meter indication, see figure 4-16, using a method described by Calvert and Mildwater<sup>10</sup> in 1963.

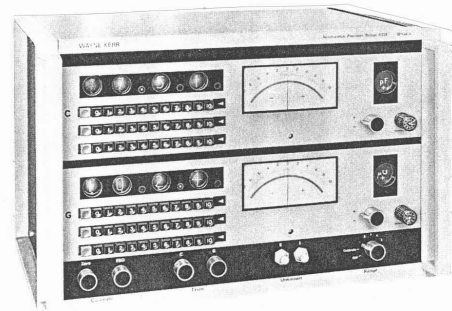

**4-16 Universal Impedance Bridge  
"Push-Button Bridge"  
W-K Model B641 1966**

A milestone was reached in 1965 with the introduction of the first digitally-balanced automatic capacitance bridge, the GR 1680, developed by R.G. Fulks<sup>11</sup>. This used transistor-switched, weighted-conductance, digital-to-analog converters to adjust the balance of an active transformer-ratio-arm bridge circuit, see figure 4-17. The bridge unbalance voltage was sampled and phase detected and the result drove reversible counters that drove the D/A converters until a null was reached. Alternately, each digit could be balanced separately, starting with the first, a technique that allowed a faster balance. The digital inputs to the converters at balance were the digital outputs. External signals could control the test conditions and the "start" pulse and the digital output was available on a rear connector. As a

result the 1680 was used in many automatic test systems, usually with a DEC PDP-8 computer. One might note that this instrument was designed before analog or digital integrated circuits were available and thus used only transistors, more than 250 of them.

The GR 1680 measured equivalent parallel C and G and also D. It could also measure negative capacitance so that it could balance an inductance but a calculation was necessary to get the value ( $L = -1/\omega^2 C$ ). The later GR type 1683 by Coughlin<sup>12</sup> measured series R, L, and C using several different active bridge configurations which were active modifications of the basic bridges in the old manual "universal" bridges. Again, the variable elements were switched-conductance D/A converters. Micro Instruments Co. made a 1 MHz Automatic Bridge, the Model 6201, as did GR. Their type 1682 by Sette<sup>13</sup> was a transformer-ratio-arm bridge that switched capacitors of weighted value to get the balance. Other Automatic bridges were made by Hewlett-Packard in the US, and Marconi, Culton and Wayne-Kerr in the UK and Kohan in Japan.

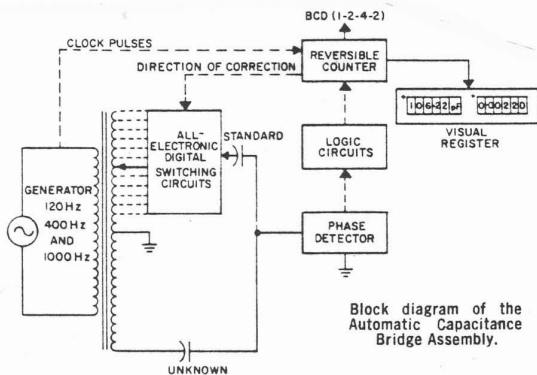
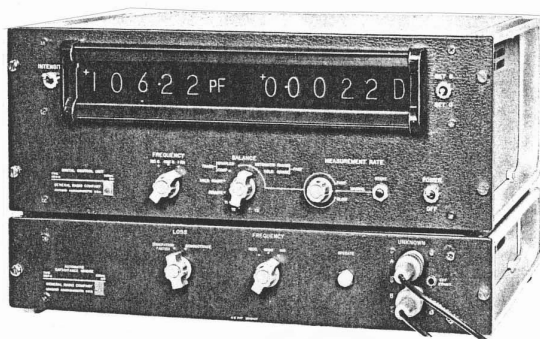

**4-17 Automatic Capacitance Bridge  
GR Type 1680-A 1965**

#### 4.5 Computer-Bridge Systems.

Many early component-sorting systems had no computer but used instead digital limit comparators<sup>14</sup>. The component handler initiated the measurement and, when the measurement was complete, the digital bridge output was compared to preset limits and the handler was indexed starting the next cycle. However, if the system included a computer, components could be sorted in many categories ("bins") and thus it often paid to use a computer rather than several separated limit comparators. Moreover, the computer gave many other advantages: control, memory, printer interface etc.

But the bridge-computer combination allowed more than just sorting. Many special purpose systems were designed to do what couldn't have been done before. A good example was testing multiple-pair telephone cables. A system by Fulks and Lamont<sup>15</sup> used the 1680 automatic bridge to test telephone cables with 100 twisted pairs for crosstalk between them.. Using only guarded capacitance measurements, it calculated mutual capacitance and unbalance to ground and then measured all 4950 pair-to-pair combinations for unbalance between pairs. Previously only manual, sampling measurements had been made and they took much more time than the automatic system.

An automated, precision, resistance-measuring system was developed by Geraci et al<sup>16</sup> in 1969. An automatic calibration system designed for the US Army was described by Seeley & Barron<sup>17</sup> that calculated many impedance quantities, ac as well as dc, from automatic measurements on basic voltage and resistance standards. A 50 Hz to 250 MHz, transmission measuring system by Geldart, Haymie and Schleich<sup>18</sup> of Bell Labs calculated a variety of parameters from automatic measurements and stored calibration constants. Also microwave test systems were automated such as that by Adam<sup>19</sup>.

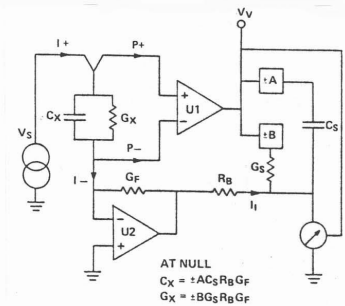
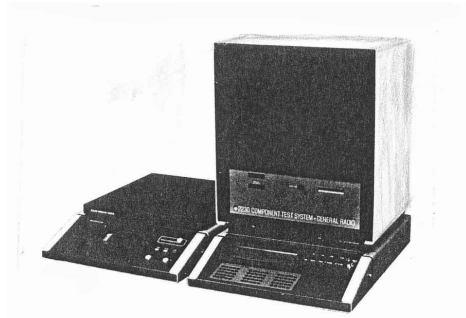

4-18 Passive Test System  
GR Type 2230 1975

#### 4.6 Computers in Bridges and Meters

When computers came on single circuit boards, such as the DEC LSI-11, the computer could be incorporated with instruments in the same box as was done in the GR 2230 Passive Test System that measured dc quantities as well as ac impedance. Unlike earlier automatic bridges, the ac bridge in this system designed by Kabele<sup>20</sup> (1975) (see figure 4-18) depended on the computer; it could not operate without it. Besides controlling the bridge balance, the computer calculated the desired parameters. The bridge itself measured only parallel C and G, but the computer calculated not only series and parallel C and R, and D and Q, it also calculated inductance from negative capacitance. Thus, because of the computer, the bridge did not have to be "direct reading" in the desired measurement parameter and only one bridge circuit was needed to measure all impedance parameters.



4-19 1MHz Automatic Capacitance Br.  
BEC Model 76 A 1976

When small, inexpensive microprocessors were available they could be put in an instrument. The first microprocessor-controlled bridge was the BEC 76A, Automatic Capacitance Bridge figure 4-19, designed by R. C. Lee<sup>21</sup> (1976). Besides controlling the

bridge, the microprocessor calculated series C and R, as well as D and Q, from the parallel C and G balance values. It also calculated the percent deviation of the measured value from an entered value and it applied stored zero corrections. These are important features that are now included in all current impedance measuring instruments. The ESI 296 Auto LCR Meter (1976) was a microprocessor-controlled impedance meter that converted the results into many parameter combinations as well as percent deviation from an entered L, R or C value (figure 4-20).



4-20 Auto LCR Meter  
ESI Model 296 1976

#### 4.7 Computing Impedance Meters

The microprocessor could do more than control a bridge and operate on the results; it could change the basic measurement method, combining the speed of digital meters with the accuracy of automatic bridges and at a lower cost than either. The microprocessor could make a complex division and thus calculate complex impedance using the ac version of Ohm's Law,  $Z = E/I$ . The current was measured by placing a standard resistor in series with the DUT and measuring the voltage across each sequentially, with the same amplifier and A/D converter (see the simplified diagram in figure 4-21). Because the same detector was used for both measurements, its gain and phase shift had no effect, they canceled in the division. Moreover, the two phase references, which were used to get the quadrature components of each voltage, needed only to be at  $90^\circ$  with each other, their phase relationship to the voltage or current of the DUT had no effect. This allowed the  $90^\circ$  phase relationship to be made easily by digital means and, as a result, the method gave very good phase accuracy as well as magnitude accuracy if an A/D with high resolution and linearity was used. The microprocessor calculated any impedance quantity from the measured complex voltage ratio and the known value of the current-measuring standard resistor.

This method was first used on the GR 1657 "Digibridge™" in 1976, figure 4-21, designed by Gipe, Hall and Sullivan<sup>22</sup>. Its name was a misnomer for it was a really a meter, not a balanced bridge, although "bridge" was (and still is) often loosely used to refer to any impedance measuring device. This was only a 0.2% instrument (.001 in D), but was much less expensive than automatic bridges of comparable accuracy. GR was very hesitant to describe the operation of their new

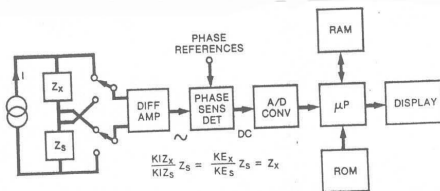
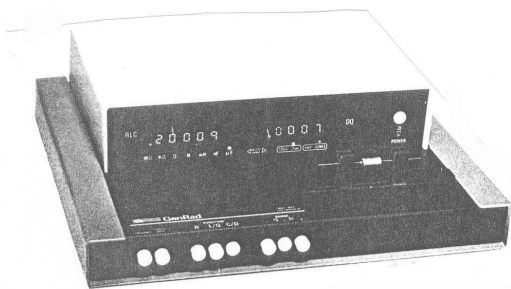

4-21 RLC Digibridge™  
GR Type 1657 1976

instruments in any detail in a paper even though the instruction manual for the 1657 gave the full circuit diagram. As a result, the best description of the new method was in the HP Journal<sup>23</sup> in

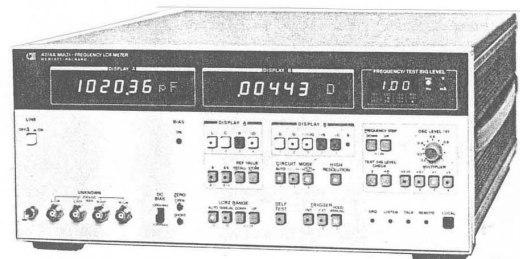

4-22 Multi-Frequency LCR Meter  
HP Model 4274 1978

their description of the HP models 4274A (figure 4-22) and 4575A that use the same basic method (but with the front-end circuit of figure 4-10). These instruments were designed by Maeda and Narimatsu of YHP.

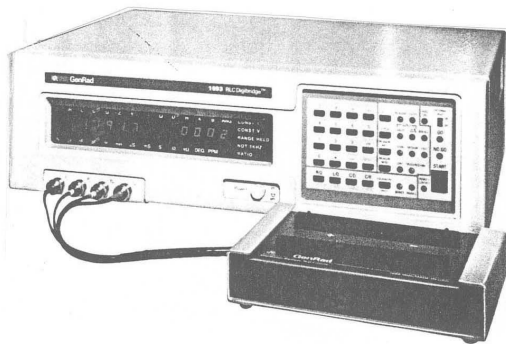

**4-23 Precision RLC Digibridge™  
GR Type 1693 1988**



**4-24 Video Bridge®  
FSI Model 2100 1981**



**4-25 LCR Meter  
Stanford Res. SR 715 1991**

Microprocessor-based digital impedance meters were or are still made by at least twenty companies including Agilent (formerly HP), Quadtech, Stanford Research (see figure 4-25), Wayne Kerr (figure 4-26) and Tinsley (UK), Keithley, Fluke/Philips, Danbridge (Denmark), Chen Hwa and Chroma (Taiwan), Hioki (Japan), Goodwill (Korea, figure 2-27), Combinova (Sweden) and HuGuang and MPC (PRC), see appendix C. Tegam sells many of the instruments of the ESI line and IET Labs acquired the GR Digibridge™ line of instruments.

GR followed the 1657 with instruments with tighter and tighter specifications, wider ranges and a keyboard that allowed numeric entry as well as selection of parameters and test conditions. The last of the line, the GR 1693 (figure 4-23) had an accuracy of .02% at 1 kHz and went from 12 Hz to 200 kHz. (This instrument and other Digibridges™ are now sold by IET Labs). The GR 1693, like other precise instruments of this type, is calibrated by external standards rather than relying on the accuracy of the range resistors. Thus they can be recalibrated regularly and the actual value of their internal standards was not critical. As wider frequency ranges were used,

calibrations were made at several frequencies with calculated corrections at the intermediate frequencies. Note that the frequency used has to be precisely known in order to calculate capacitance and inductance accurately. Inexpensive crystal oscillators are accurate enough for many of these instruments but the most accurate have their frequency calibrated against an external standard and a correction entered.

Most of these instruments had two displays, primary (RLCZ) and secondary (DQ etc) that used light - emitting diodes (LEDs) and some method of displaying units and test conditions. The ESI Type 2100/2110 "VideoBridge" (figure 4-24), designed by N. Morrison, has a CRT readout that gave a high resolution readout and also displayed the units, the test frequency and voltage and other information. Later, liquid-crystal displays (LCDs) were used which could display a lot of information without the disadvantages of CRTs (high voltage, noise, power consumption and cost).

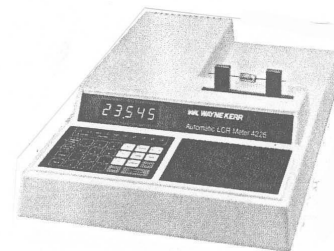

**4-26 Automatic LCR Meter  
W-K Model 4225 1984**



These instruments are all quite similar in principle, if not in appearance, and most all have extremely wide range of R, C and L, good 3-terminal (guarding) and 4-terminal ("Kelvin") capability. They also have the advantages of speed, some up to 50 or more measurements per second, the current record being 5.6 ms measurements set by the Agilent (formerly HP) E4980A. Many have only low-frequency capability but many others several can go up to 1 MHz such as HP's 4284, figure 4-28 and the QuadTech 7600, figure 4-29. Agilent's extensive line of RLC meters also extends up to much higher frequencies with the older 4275 (1978) that goes to 10 MHz and the 4285 that goes to 30 MHz. They also have replaced their old analog-display Vector digital display of magnitude and phase and operates up to 110 MHz. This makes two-terminal measurements as does their type 4191A RF Impedance Analyzer that goes to 1000 MHz and which measures R, L, C, D and Q as well as  $|Z|$ ,  $|Y|$ ,  $|\Gamma|$  and  $\theta$  (figure 4-30).

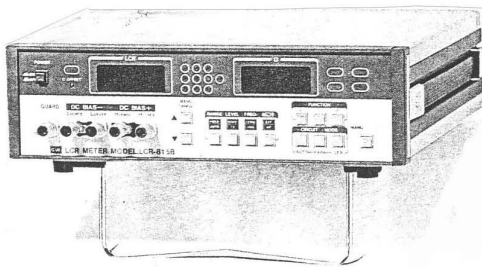

**4-27 LCR Meter  
Goodwill Model 815B c1995**



**4-29 Precision LCR Meter  
QT Type 7600 1995**

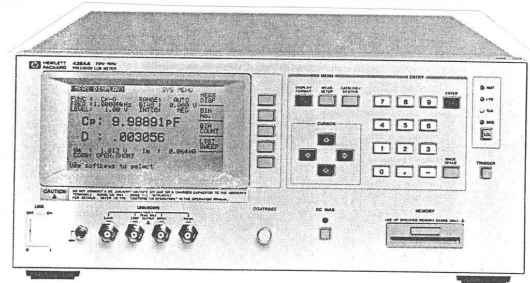

**4-28 Precision LCR Meter  
HP Model 4284 1988**

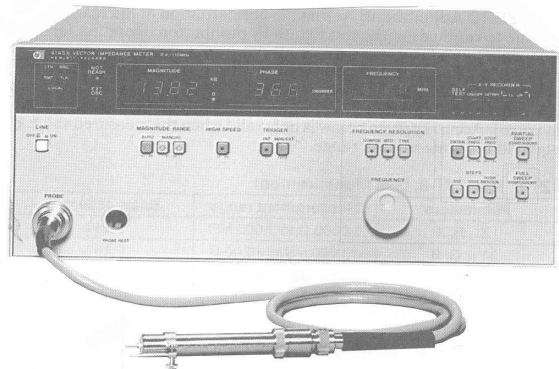

**4-30 Vector Impedance Meter  
HP Model 4193A c1990**

A noteworthy meter with special capability is the Wayne-Kerr Inductance Analyzer, model 3245 (figure 4-31). Besides measuring the usual ac impedance parameters over a wide frequency range it also measures dc resistance and turns ratio. It supplies an ac signal level up to 5 volts and the dc bias needed to test iron-cored transformers and chokes, up to 1 ampere internally and 100 amperes with external bias units.



**4-31 Precision Inductance Analyzer  
W-K Type 3245 1982**

#### 4.8 Instruments in Use Today

These microprocessor-based impedance meters have replaced all of the manual RLC bridges, automatic bridges and the older, non-computing, digital, and analog meters. Some of the companies that made these earlier instruments are still around, but many of them have disappeared, either they have gone out of business or were bought by other companies.

Many of these  $\mu\text{P}$  based meters have excellent repeatability making them ideal for the comparisons of standards of similar value. Some, such as the GR/IET Labs 1689 and 1693, have ppm resolution for comparison measurements and have a standard deviation at 1 kHz of about 2 ppm for a 1 second measurement. These can make  $3\sigma$  comparisons to 1 ppm by averaging fifty measurements, often with a total measurement time less than the time it would take to balance a precision bridge. As a result these meters are used in many standards labs for comparing standards of all types. These meters are better than any commercial bridge for comparison of standard inductors and high-valued capacitors. NIST recognized this and has used a GR 1689M  $\mu\text{P}$ -based meter for comparing inductance standards<sup>24</sup>.

These meters do have eventual limitations in both accuracy and precision. Their accuracy depends on the linearity of their amplifiers and A/D converters, but is mainly limited by their calibration and the stability of their internal standards. These factors limit ratio accuracy as well and ratio accuracy is needed for scaling impedance values. (Ratio accuracy is not limited by calibration accuracy if both measurements are made on the same range.) Their precision is limited by A/D resolution and eventually by noise. Manual transformer-ratio-arm (TRA) bridges apply higher signal levels and thus are less affected by noise and they have very good ratio accuracy. Thus older manual precision capacitance bridges, such as the GR 1615 and 1616, are still used for precision capacitance calibrations. However they don't have the many advantages of computer control.

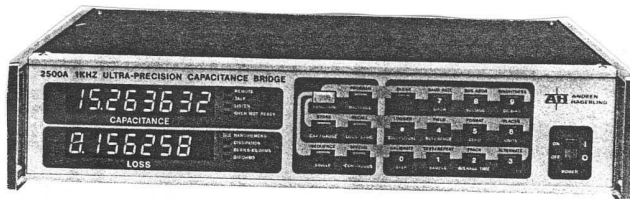

**4-32 1 kHz Automatic Capacitance Br.  
A-H Type 2500A 1992  
( Type 2500 1985)**

A high-resolution, automatically balanced bridge would be slow and expensive to make because of many switches that would be required. Andeen-Hagerling<sup>25</sup> has solved this problem by making a hybrid combination of a bridge and meter, their Capacitance Bridge model 2500A, figure 4-32, which has 3 ppm accuracy and .07 ppm resolution at 1 kHz. This instrument has an  $8\frac{1}{2}$  digit readout, the first three digits are automatically-switched, high-precision capacitors and

the last digits come from a high-resolution A/D converter. This instrument is also used by NIST<sup>26</sup> and by many standards labs as well.

Although low-frequency ac meters can be used to test most resistors, resistance measurements are usually made today using digital dc multimeters, both in the shop, on the production floor and in the lab. These, except for the cheapest, are capable of computer control and the advantages that go with it. Hand-held, digital volt-ohmmeters have replaced delicate, less accurate analog meters for casual use. Computer-controlled digital multimeters, DMMs, are fast and accurate enough to replace limit bridges for sorting resistors. Some standardization labs still use traditional high-resolution bridges and ratio sets for comparing

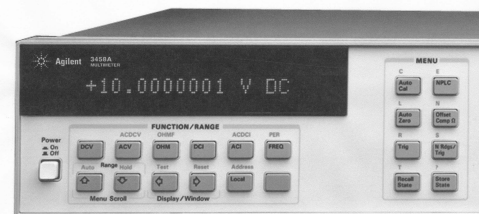

**4-33 Digital Multimeter  
Agilent Type 3458A**



**4-34 Digital Multimeter  
Fluke Type 8508A**

resistance standards, but many use precision DMMs such as the 8½ digit Agilent 3458A (figure 4-33) or the Fluke 8508A (figure 4-34) that have accuracies of a few ppm and resolution better than 0.1 ppm. The Guildline Current-Comparator Bridge is still one of the best instruments for scaling resistance calibrations to different values. An alternative

is to use series-parallel ratio boxes for scaling, making only 1:1 measurements with a high-resolution DMMs or a conventional DRRS. The main limitation of DMMs is at extremely low and extremely high values of resistance. Specialized micro-ohmmeters apply higher currents and thus get better resolution at very low values. At very high values, analog and digital megohmmeters apply much higher voltages for better sensitivity. For precision high-resistance work, the updated Guildline Teraohmmeter, model 6520, is probably the best.

#### **4.9 A Long Way From Ohm**

The history of impedance measurements illustrates the changes in the science of electricity and the development of electronics from the age of the early experimenters to the computer age of today. The designers of impedance measuring instruments took advantage of the latest ideas and devices to make their products more useful and more competitive. These instruments had to measure the widening range of component values with accuracies consistent with the increasing accuracies of new components at measurement rates sufficient to handle the exploding number of components used. Thus their development was driven by needs of technical change and realized by results technological advances.

It's somewhat ironic that the present day calculating impedance meters use Ohm's Law in a more obvious way than do classic bridges and older impedance meters. GR was once accused of patenting Ohm's Law in their "Digibridge™" patent<sup>27</sup> that gives the complex formula for the division of two complex numbers as the means of calculating impedance from measurements of voltage and current. It is also ironic, and perhaps sad, that your author, who has been fascinated by the history of classic bridges and has designed several commercial bridges, should have been instrumental in the end of the long bridge era. To my knowledge no new, commercial, true (nulled) bridge, manual or automatic, has been introduced for many years.

## References Part IV

- 4.1 Schmidt, H., "Digital voltmeters for under \$100", *Electronics*, Nov 28, 1966
- 4.2 Gilbert, R.W., "Pulse-Time Encoding Apparatus" US Patent 3,074,057 Filed March 12, 1957, Issued January 15, 1963
- 4.3 Tsao, S.H., "An Accurate, Semiautomatic Technique of Measuring High Resistances", *IEEE Trans on I&M*, Vol. IM-16, No.3, Sept 1967, pp. 220-225
- 4.4 Maeda, K., "An Automatic, Precision 1-MHz Digital LCR Meter" *HP Jour* March 1974
- 4.5 Graham, J.F., "Automatic A-C Bridges" *Electronics*, Vol 30, pp110-116 Feb 1951
- 4.6 Frischman, P.G., "Measuring Dielectric Properties Automatically" *Electronics*, Aug 5 1960, pp56-57
- 4.7 Yoshimoto, Katsumi, "A New Universal Impedance Bridge with Simplified, Semi-automatic Tuning" *HP Jour* vol. 18. no. 1 August 1966 pp. 2-5
- 4.8 Schmidt, T. and Kolbe, D. "Automatic Precision Bridge RLCB" *News from Rohde & Schwarz*, Vol 36, No. 9, 1969
- 4.9 Whatley, L.A., US Patent 3,315,153 "Bridge Circuit Employing Self-Balancing Control Means" filed Jan 21, 1965, dated April 18, 1967
- 4.10 Calvert, R and Mildwater, J. "Self-Balancing Transformer Ratio Arm Bridges" *Electronic Engineering*, Dec 1963 pp 782-784
- 4.11 Fulks, R.G., "The Automatic Capacitance Bridge", *GR Experimenter* April 1965. See also Fulks, R.G., US Patent 3,562,641 "Impedance Measuring Transformer Bridge with Automatic Digital Balancing Circuit", Filed Nov. 25 1968, issued Feb 9, 1971
- 4.12 Coughlin, T.J. "Five-Terminal Automatic RLC Bridge" *GR Experimenter* Vol 44, March-June 1970
- 4.13 Sette, R.F., "Five-Terminal, 1-MHz Automatic Capacitance Bridge" *GR Experimenter* Nov/Dec 1969
- 4.14 McAleer H.T. and Sette, R.F. "Automatic Capacitor Test Systems" *GR Experimenter* Nov-Dec 1966
- 4.15 Fulks, R.G. and Lamont, J. "An Automatic Computer-Controlled System for the Measurement of Cable Capacitance" *Trans I&M IM-17 No 4, Dec 1968* pp 299-303
- 4.16 Geraci, E.E., Smith, H.O., Tonooka, S. & Goslin, M.B., "A Computer-Controlled, High-Precision Resistance Measuring System", paper 69-624, *ISA Annual Conference*, October 29-30 1969
- 4.17 Seeley, F.B. and Barron, W.J. "Automatic Certification of a Computer-Controlled Calibration System" *Trans I&M IM-9 Dec 1975* pp 245-252
- 4.18 Geldart, Haymie & Schleich "A 50 Hz to 250 MHz Computer Operated Transmission Measuring Set", *C.P.E.M. Digest*, June 1968
- 4.19 Adam, S.F., "A New Precision Automatic Microwave Measurement System" *C.P.E.M. Digest* pp 29-31, June 1968
- 4.20 Kabele, W.C. "A Fast Microcomputer-Controlled Admittance Bridge" *Trans I&M IM-25 No. 4 Dec 1976*, pp 541-544 (CPEM '76)  
See also Abemaim, D. "Impact of Microprocessors on Design of Analog Instrumentation", *Electro '76 Program Record*
- 4.21 Lee, R.C., Paper, *WESCON 1976*
- 4.22 Gipe, M.A., Hall, H.P. and Sullivan, R., "Microprocessor Simplifies Impedance Measurements", Session 1, Paper #4, *Wescon 1976* (GR Reprint)  
See also: Hall, H.P., "Analog tests: the microprocessor scores" *IEEE Spectrum*, April 1977 Also see reference 4.28
- 4.23 Maeda, K., and Narimatsu, Y., "Multi-Frequency LCR Meters Test Components Under Realistic Conditions", *HP Jour*, Feb. 1979
- 4.24 Chang, Y.M. and Tillett, S.B., "Calibration Procedures for Inductance Standards Using a Commercial Impedance Meter as a Comparator" *NISTIR # 4466*, Nov 1990, US Dept of Commerce
- 4.25 Andeen, C.G. and Hagerling, C.W., "High Precision Capacitance Bridge", *US Paten 4,772,844*, Filed Oct. 1, 1985, Issued Sept. 20, 1988
- 4.26 Chang, Y.M., "NIST Capacitance Measurement Assurance Program (MAP)" *Meas. Science Conf 1993*, Section 1-B, paper #1

4.27 Hall, H.P., "Method of and apparatus for the measurement of impedance and other parameters with microprocessor calculating techniques", US Patent 4,196,475, Filed Sept 2, 1976, Issued 1980