

GENERAL DESCRIPTION

The DS33R11 extends a 10/100 Ethernet LAN segment by encapsulating MAC frames in HDLC or X.86 (LAPS) for transmission over a T1/E1/J1 data stream.

The device performs store-and-forward of packets with full wire-speed transport capability. The built-in Committed Information Rate (CIR) Controller provides fractional bandwidth allocation up to the line rate in increments of 512kbps. The DS33R11 can operate with an inexpensive external processor.

APPLICATIONS

Transparent LAN Service
LAN Extension
Ethernet Delivery Over T1/E1/J1

FUNCTIONAL DIAGRAM

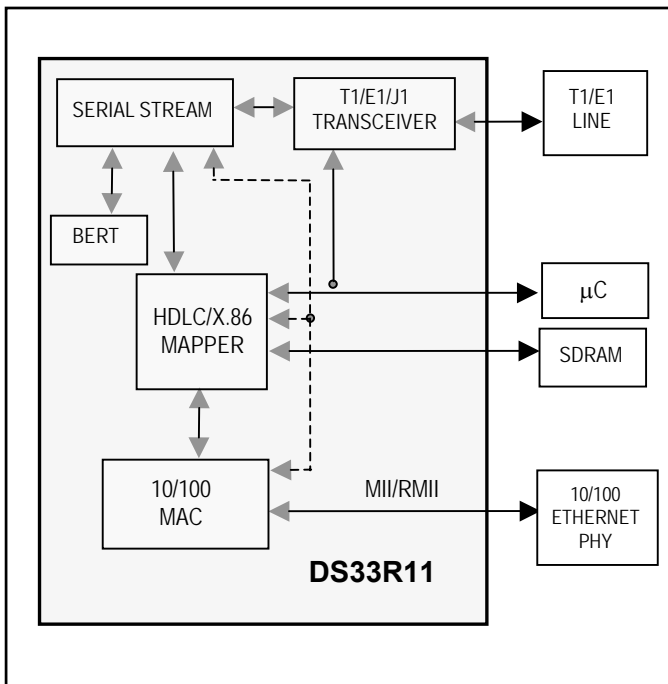

FEATURES

- 10/100 IEEE 802.3 Ethernet MAC (MII and RMII) Half/Full Duplex with Automatic Flow Control
- Integrated T1/E1/J1 Framer and LIU
- HDLC/LAPS Encapsulation with Programmable FCS and Interframe Fill
- Committed Information Rate Controller Provides Fractional Allocations in 512kbps Increments
- Programmable BERT for Serial (TDM) Interface
- External 16MB, 100MHz SDRAM Buffering
- Parallel Microprocessor Interface
- 1.8V, 3.3V Supplies
- Reference Design Routes on Two Signal Layers
- IEEE 1149.1 JTAG Support

Features continued on page [11](#).

ORDERING INFORMATION

PART	TEMP RANGE	PIN-PACKAGE
DS33R11	-40°C to +85°C	256 BGA

Note: Some revisions of this device may incorporate deviations from published specifications known as errata. Multiple revisions of any device may be simultaneously available through various sales channels. For information about device errata, click here: www.maxim-ic.com/errata.

TABLE OF CONTENTS

1	DESCRIPTION	9
2	FEATURE HIGHLIGHTS.....	11
2.1	GENERAL.....	11
2.2	MICROPROCESSOR INTERFACE.....	11
2.3	HDLC ETHERNET MAPPING	11
2.4	X.86 (LINK ACCESS PROTOCOL FOR SONET/SDH) ETHERNET MAPPING.....	11
2.5	ADDITIONAL HDLC CONTROLLERS IN THE INTEGRATED T1/E1/J1 TRANSCEIVER	12
2.6	COMMITTED INFORMATION RATE (CIR) CONTROLLER	12
2.7	SDRAM INTERFACE.....	12
2.8	MAC INTERFACE.....	12
2.9	T1/E1/J1 LINE INTERFACE	13
2.10	CLOCK SYNTHESIZER.....	13
2.11	JITTER ATTENUATOR.....	13
2.12	T1/E1/J1 FRAMER	14
2.13	TDM BUS	14
2.14	TEST AND DIAGNOSTICS.....	15
2.15	SPECIFICATIONS COMPLIANCE.....	16
3	APPLICATIONS	17
4	ACRONYMS AND GLOSSARY	18
5	MAJOR OPERATING MODES	19
6	BLOCK DIAGRAMS.....	20
7	PIN DESCRIPTIONS.....	25
7.1	PIN FUNCTIONAL DESCRIPTION.....	25
8	FUNCTIONAL DESCRIPTION.....	41
8.1	PROCESSOR INTERFACE	42
8.1.1	<i>Read-Write/Data Strobe Modes.....</i>	<i>42</i>
8.1.2	<i>Clear on Read.....</i>	<i>42</i>
8.1.3	<i>Interrupt and Pin Modes.....</i>	<i>42</i>
9	ETHERNET MAPPER	43
9.1	ETHERNET MAPPER CLOCKS.....	43
9.1.1	<i>Ethernet Interface Clock Modes.....</i>	<i>45</i>
9.1.2	<i>Serial Interface Clock Modes.....</i>	<i>45</i>
9.2	RESETS AND LOW POWER MODES.....	46
9.3	INITIALIZATION AND CONFIGURATION.....	47
9.4	GLOBAL RESOURCES	47
9.5	PER-PORT RESOURCES	47
9.6	DEVICE INTERRUPTS	48
9.7	INTERRUPT INFORMATION REGISTERS	50
9.8	STATUS REGISTERS	50
9.9	INFORMATION REGISTERS	50
9.10	SERIAL INTERFACE.....	50
9.11	CONNECTIONS AND QUEUES	51
9.12	ARBITER	52
9.13	FLOW CONTROL.....	53
9.13.1	<i>Full Duplex Flow Control.....</i>	<i>54</i>
9.13.2	<i>Half Duplex Flow Control.....</i>	<i>55</i>
9.13.3	<i>Host-Managed Flow Control.....</i>	<i>55</i>
9.14	ETHERNET INTERFACE PORT	56

9.14.1	DTE and DCE Mode	58
9.15	ETHERNET MAC	59
9.15.1	MII Mode Options.....	61
9.15.2	RMII Mode.....	61
9.15.3	PHY MII Management Block and MDIO Interface	62
9.16	BERT IN THE ETHERNET MAPPER	62
9.16.1	Receive Data Interface	63
9.16.2	Repetitive Pattern Synchronization.....	64
9.16.3	Pattern Monitoring.....	64
9.16.4	Pattern Generation.....	64
9.17	TRANSMIT PACKET PROCESSOR.....	65
9.18	RECEIVE PACKET PROCESSOR.....	66
9.19	X.86 ENCODING AND DECODING.....	68
9.20	COMMITTED INFORMATION RATE CONTROLLER.....	71
10	INTEGRATED T1/E1/J1 TRANSCEIVER	72
10.1	T1/E1/J1 CLOCKS	72
10.2	PER-CHANNEL OPERATION.....	73
10.3	T1/E1/J1 TRANSCEIVER INTERRUPTS.....	73
10.4	T1 FRAMER/FORMATTER CONTROL AND STATUS	74
10.4.1	T1 Transmit Transparency.....	74
10.4.2	AIS-CI and RAI-CI Generation and Detection	74
10.4.3	T1 Receive-Side Digital-Milliwatt Code Generation.....	75
10.5	E1 FRAMER/FORMATTER CONTROL AND STATUS.....	76
10.5.1	Automatic Alarm Generation.....	77
10.6	PER-CHANNEL LOOPBACK.....	77
10.7	ERROR COUNTERS.....	78
10.7.1	Line-Code Violation Counter (TR.LCVCR)	78
10.7.2	Path Code Violation Count Register (TR.PCVCR)	79
10.7.3	Frames Out-of-Sync Count Register (TR.FOSCR)	80
10.7.4	E-Bit Counter (TR.EBCR)	80
10.8	DS0 MONITORING FUNCTION	81
10.9	SIGNALING OPERATION	82
10.9.1	Processor-Based Receive Signaling	82
10.9.2	Hardware-Based Receive Signaling.....	83
10.9.3	Processor-Based Transmit Signaling	84
10.9.4	Hardware-Based Transmit Signaling.....	85
10.10	PER-CHANNEL IDLE CODE GENERATION	86
10.10.1	Idle-Code Programming Examples	87
10.11	CHANNEL BLOCKING REGISTERS	88
10.12	ELASTIC STORES OPERATION.....	88
10.12.1	Receive Elastic Store.....	88
10.12.2	Transmit Elastic Store.....	89
10.12.3	Elastic Stores Initialization	89
10.12.4	Minimum Delay Mode	89
10.13	G.706 INTERMEDIATE CRC-4 UPDATING (E1 MODE ONLY).....	90
10.14	T1 BIT-ORIENTED CODE (BOC) CONTROLLER.....	91
10.14.1	Transmit BOC	91
10.15	RECEIVE BOC	91
10.16	ADDITIONAL (SA) AND INTERNATIONAL (SI) BIT OPERATION (E1 ONLY).....	92
10.16.1	Method 1: Internal Register Scheme Based on Double-Frame.....	92
10.16.2	Method 2: Internal Register Scheme Based on CRC4 Multiframe	92
10.17	ADDITIONAL HDLC CONTROLLERS IN T1/E1/J1 TRANSCEIVER.....	93
10.17.1	HDLC Configuration.....	93
10.17.2	FIFO Control	95
10.17.3	HDLC Mapping.....	95

10.17.4 FIFO Information	96
10.17.5 Receive Packet-Bytes Available	96
10.18 LEGACY FDL SUPPORT (T1 MODE)	97
10.18.1 Overview	97
10.18.2 Receive Section	97
10.18.3 Transmit Section	98
10.19 D4/SLC-96 OPERATION	98
10.20 PROGRAMMABLE IN-BAND LOOP CODE GENERATION AND DETECTION	99
10.21 LINE INTERFACE UNIT (LIU)	100
10.21.1 LIU Operation	100
10.21.2 Receiver	100
10.21.3 Transmitter	102
10.22 MCLK PRESCALER	103
10.23 JITTER ATTENUATOR	103
10.24 CMI (CODE MARK INVERSION) OPTION	103
10.25 RECOMMENDED CIRCUITS	104
10.26 T1/E1/J1 TRANSCEIVER BERT FUNCTION	108
10.26.1 BERT Status	108
10.26.2 BERT Mapping	108
10.26.3 BERT Repetitive Pattern Set	110
10.26.4 BERT Bit Counter	110
10.26.5 BERT Error Counter	110
10.26.6 BERT Alternating Word-Count Rate	110
10.27 PAYLOAD ERROR-INSERTION FUNCTION (T1 MODE ONLY)	111
10.27.1 Number-of-Errors Registers	111
10.28 PROGRAMMABLE BACKPLANE CLOCK SYNTHESIZER	112
10.29 FRACTIONAL T1/E1 SUPPORT	112
10.30 T1/E1/J1 TRANSMIT FLOW DIAGRAMS	113
11 DEVICE REGISTERS	117
11.1 REGISTER BIT MAPS	118
11.1.1 Global Ethernet Mapper Register Bit Map	118
11.1.2 Arbiter Register Bit Map	119
11.1.3 BERT Register Bit Map	119
11.1.4 Serial Interface Register Bit Map	120
11.1.5 Ethernet Interface Register Bit Map	122
11.1.6 MAC Register Bit Map	123
11.2 GLOBAL REGISTER DEFINITIONS FOR ETHERNET MAPPER	134
11.3 ARBITER REGISTERS	143
11.3.1 Arbiter Register Bit Descriptions	143
11.4 BERT REGISTERS	144
11.5 SERIAL INTERFACE REGISTERS	151
11.5.1 Serial Interface Transmit and Common Registers	151
11.5.2 Serial Interface Transmit Register Bit Descriptions	151
11.5.3 Transmit HDLC Processor Registers	152
11.5.4 X.86 Registers	159
11.5.5 Receive Serial Interface	161
11.6 ETHERNET INTERFACE REGISTERS	174
11.6.1 Ethernet Interface Register Bit Descriptions	174
11.6.2 MAC Registers	186
11.7 T1/E1/J1 TRANSCEIVER REGISTERS	201
11.7.1 Number-of-Errors Left Register	299
12 FUNCTIONAL TIMING	300
12.1 FUNCTIONAL SERIAL I/O TIMING	300
12.2 MII AND RMII INTERFACES	301
12.3 TRANSCEIVER T1 MODE FUNCTIONAL TIMING	303

12.4 E1 MODE.....	308
13 OPERATING PARAMETERS	313
13.1 THERMAL CHARACTERISTICS.....	314
13.2 MII INTERFACE.....	315
13.3 RMII INTERFACE.....	317
13.4 MDIO INTERFACE.....	319
13.5 TRANSMIT WAN INTERFACE.....	320
13.6 RECEIVE WAN INTERFACE.....	321
13.7 SDRAM TIMING.....	322
13.8 MICROPROCESSOR BUS AC CHARACTERISTICS.....	324
13.9 AC CHARACTERISTICS: RECEIVE-SIDE.....	327
13.10 AC CHARACTERISTICS: BACKPLANE CLOCK TIMING.....	331
13.11 AC CHARACTERISTICS: TRANSMIT SIDE.....	332
13.12 JTAG INTERFACE TIMING.....	335
14 JTAG INFORMATION.....	336
14.1 JTAG TAP CONTROLLER STATE MACHINE DESCRIPTION.....	337
14.2 INSTRUCTION REGISTER.....	339
14.3 JTAG ID CODES.....	341
14.4 TEST REGISTERS.....	341
14.4.1 <i>Boundary Scan Register</i>	341
14.4.2 <i>Bypass Register</i>	341
14.4.3 <i>Identification Register</i>	341
14.5 JTAG FUNCTIONAL TIMING.....	342
15 PACKAGE INFORMATION.....	343
15.1 PACKAGE OUTLINE DRAWING OF 256-BGA (VIEW FROM BOTTOM OF DEVICE).....	343
16 DOCUMENT REVISION HISTORY.....	344

LIST OF FIGURES

Figure 3-1. Ethernet-to-WAN Extension (With or Without Framing)	17
Figure 6-1. Main Block Diagram	20
Figure 6-2. Block Diagram of T1/E1/J1 Transceiver	21
Figure 6-3. Receive and Transmit T1/E1/J1 LIU	22
Figure 6-4. Receive and Transmit T1/E1/J1 Framer	23
Figure 6-5. T1/E1/J1 Backplane Interface	24
Figure 7-1. 256-Ball BGA Pinout	40
Figure 9-1. Clocking for the DS33R11	44
Figure 9-2. Device Interrupt Information Flow Diagram	49
Figure 9-3. Flow Control Using Pause Control Frame	55
Figure 9-4. IEEE 802.3 Ethernet Frame	56
Figure 9-5. Configured as DTE Connected to an Ethernet PHY in MII Mode	58
Figure 9-6. DS33R11 Configured as a DCE in MII Mode	59
Figure 9-7. RMII Interface	61
Figure 9-8. MII Management Frame	62
Figure 9-9. PRBS Synchronization State Diagram	63
Figure 9-10. Repetitive Pattern Synchronization State Diagram	64
Figure 9-11. HDLC Encapsulation of MAC Frame	67
Figure 9-12. LAPS Encoding of MAC Frames Concept	68
Figure 9-13. X.86 Encapsulation of the MAC frame	69
Figure 10-1. T1/E1/J1 Clock Map	72
Figure 10-2. Simplified Diagram of Receive Signaling Path	82
Figure 10-3. Simplified Diagram of Transmit Signaling Path	84
Figure 10-4. CRC-4 Recalculate Method	90
Figure 10-5. Typical Monitor Application	101
Figure 10-6. CMI Coding	103
Figure 10-7. Basic Interface	104
Figure 10-8. E1 Transmit Pulse Template	105
Figure 10-9. T1 Transmit Pulse Template	105
Figure 10-10. Jitter Tolerance	106
Figure 10-11. Jitter Tolerance (E1 Mode)	106
Figure 10-12. Jitter Attenuation (T1 Mode)	107
Figure 10-13. Jitter Attenuation (E1 Mode)	107
Figure 10-14. Optional Crystal Connections	108
Figure 10-15. Simplified Diagram of BERT in Network Direction	109
Figure 10-16. Simplified Diagram of BERT in Backplane Direction	109
Figure 10-17. T1/J1 Transmit Flow Diagram	113
Figure 10-18. E1 Transmit Flow Diagram	115
Figure 12-1. Tx Serial Interface Functional Timing	300
Figure 12-2. Rx Serial Interface Functional Timing	300
Figure 12-3. Transmit Byte Sync Functional Timing	301
Figure 12-4. Receive Byte Sync Functional Timing	301
Figure 12-5. MII Transmit Functional Timing	301
Figure 12-6. MII Transmit Half Duplex with a Collision Functional Timing	302
Figure 12-7. MII Receive Functional Timing	302
Figure 12-8. RMII Transmit Interface Functional Timing	302
Figure 12-9. RMII Receive Interface Functional Timing	303
Figure 12-10. Receive-Side D4 Timing	303
Figure 12-11. Receive-Side ESF Timing	303
Figure 12-12. Receive-Side Boundary Timing (Elastic Store Disabled)	304
Figure 12-13. Receive-Side 1.544MHz Boundary Timing (Elastic Store Enabled)	304
Figure 12-14. Receive-Side 2.048MHz Boundary Timing (Elastic Store Enabled)	305
Figure 12-15. Transmit-Side D4 Timing	305
Figure 12-16. Transmit-Side ESF Timing	306
Figure 12-17. Transmit-Side Boundary Timing (with Elastic Store Disabled)	306
Figure 12-18. Transmit-Side 1.544MHz Boundary Timing (Elastic Store Enabled)	307

Figure 12-19. Transmit-Side 2.048MHz Boundary Timing (Elastic Store Enabled).....	307
Figure 12-20. Receive-Side Timing.....	308
Figure 12-21. Receive-Side Boundary Timing (with Elastic Store Disabled).....	308
Figure 12-22. Receive-Side Boundary Timing, RSYSCLK = 1.544MHz (E-Store Enabled).....	309
Figure 12-23. Receive-Side Boundary Timing, RSYSCLK = 2.048MHz (E-Store Enabled).....	309
Figure 12-24. G.802 Timing, E1 Mode Only.....	310
Figure 12-25. Transmit-Side Timing.....	310
Figure 12-26. Transmit-Side Boundary Timing (Elastic Store Disabled).....	311
Figure 12-27. Transmit-Side Boundary Timing, TSYSCCLK = 1.544MHz (Elastic Store Enabled).....	311
Figure 12-28. Transmit-Side Boundary Timing, TSYSCCLK = 2.048MHz (Elastic Store Enabled).....	312
Figure 13-1. Transmit MII Interface Timing.....	315
Figure 13-2. Receive MII Interface Timing.....	316
Figure 13-3. Transmit RMII Interface Timing.....	317
Figure 13-4. Receive RMII Interface Timing.....	318
Figure 13-5. MDIO Interface Timing.....	319
Figure 13-6. Transmit WAN Interface Timing.....	320
Figure 13-7. Receive WAN Interface Timing.....	321
Figure 13-8. SDRAM Interface Timing.....	323
Figure 13-9. Intel Bus Read Timing (MODEC = 00).....	325
Figure 13-10. Intel Bus Write Timing (MODEC = 00).....	325
Figure 13-11. Motorola Bus Read Timing (MODEC = 01).....	326
Figure 13-12. Motorola Bus Write Timing (MODEC = 01).....	326
Figure 13-13. Receive-Side Timing.....	328
Figure 13-14. Receive-Side Timing, Elastic Store Enabled.....	329
Figure 13-15. Receive Line Interface Timing.....	330
Figure 13-16. Receive Timing Delay RCLKO to BPCLK.....	331
Figure 13-17. Transmit-Side Timing.....	333
Figure 13-18. Transmit-Side Timing, Elastic Store Enabled.....	334
Figure 13-19. Transmit Line Interface Timing.....	334
Figure 13-20. JTAG Interface Timing Diagram.....	335
Figure 14-1. JTAG Functional Block Diagram.....	336
Figure 14-2. TAP Controller State Diagram.....	339
Figure 14-3. JTAG Functional Timing.....	342

LIST OF TABLES

Table 2-1. T1-Related Telecommunications Specifications	16
Table 7-1. Detailed Pin Descriptions	25
Table 9-1. Clocking Options for the Ethernet Interface	43
Table 9-2. Reset Functions.....	46
Table 9-3. Registers Related to Connections and Queues.....	52
Table 9-4. Options for Flow Control.....	53
Table 9-5. Registers Related to Setting the Ethernet Port	57
Table 9-6. MAC Control Registers.....	60
Table 9-7. MAC Status Registers	60
Table 10-1. T1/E1/J1 Transmit Clock Source	73
Table 10-2. T1 Alarm Criteria	75
Table 10-3. E1 Sync/Resync Criteria	76
Table 10-4. E1 Alarm Criteria	77
Table 10-5 T1 Line Code Violation Counting Options.....	78
Table 10-6. E1 Line-Code Violation Counting Options.....	78
Table 10-7. T1 Path Code Violation Counting Arrangements	79
Table 10-8. T1 Frames Out-of-Sync Counting Arrangements	80
Table 10-9. Time Slot Numbering Schemes.....	85
Table 10-10. Idle-Code Array Address Mapping	86
Table 10-11. Elastic Store Delay After Initialization	89
Table 10-12. HDLC Controller Registers.....	94
Table 10-13. Transformer Specifications.....	104
Table 10-14. Transmit Error-Insertion Setup Sequence.....	111
Table 10-15. Error Insertion Examples.....	111
Table 11-1. Register Address Map.....	117
Table 11-2. Global Ethernet Mapper Register Bit Map	118
Table 11-3. Arbiter Register Bit Map	119
Table 11-4. BERT Register Bit Map	119
Table 11-5. Serial Interface Register Bit Map.....	120
Table 11-6. Ethernet Interface Register Bit Map	122
Table 11-7. MAC Indirect Register Bit Map	123
Table 11-8. T1/E1/J1 Transceiver Register Bit Map (Active when $\overline{CST} = 0$)	125
Table 13-1. Recommended DC Operating Conditions.....	313
Table 13-2. DC Electrical Characteristics.....	313
Table 13-3. Thermal Characteristics	314
Table 13-4. Theta-JA vs. Airflow	314
Table 13-5. Transmit MII Interface	315
Table 13-6. Receive MII Interface	316
Table 13-7. Transmit RMII Interface.....	317
Table 13-8. Receive RMII Interface.....	318
Table 13-9. MDIO Interface	319
Table 13-10. Transmit WAN Interface	320
Table 13-11. Receive WAN Interface	321
Table 13-12. SDRAM Interface Timing.....	322
Table 13-13. AC Characteristics—Microprocessor Bus Timing	324
Table 13-14. AC Characteristics: Receive Side	327
Table 13-15. AC Characteristics: Backplane Clock Synthesis.....	331
Table 13-16. AC Characteristics: Transmit Side	332
Table 13-17. JTAG Interface Timing	335
Table 14-1. Instruction Codes for IEEE 1149.1 Architecture	340
Table 14-2. ID Code Structure.....	341

1 DESCRIPTION

The DS33R11 provides interconnection and mapping functionality between Ethernet Packet Systems and T1/E1/J1 WAN Time-Division Multiplexed (TDM) systems. The device is composed of a 10/100 Ethernet MAC, Packet Arbiter, Committed Information Rate Controller (CIR), HDLC/X.86 (LAPS) Mapper, SDRAM interface, control ports, Bit Error Rate Tester (BERT), and integrated T1/E1/J1 Transceiver. The packet interface consists of a MII/RMII Ethernet PHY interface. The Ethernet interface can be configured for 10Mbit/s or 100Mbit/s service. The DS33R11 encapsulates Ethernet traffic with HDLC or X.86 (LAPS) encoding to be transmitted over a T1, E1, or J1 line. The T1/E1/J1 interface also receives encapsulated Ethernet packets and transmits the extracted packets over the Ethernet ports. Access is provided to the signals between the Serial port and the integrated T1/E1/J1 Transceiver.

The device includes a software-selectable T1, E1, or J1 single-chip transceiver (SCT) for short-haul and long-haul applications. The transceiver is composed of an LIU, framer, and two additional HDLC controllers. The transceiver is software compatible with the DS2155 and DS2156.

The LIU is composed of transmit and receive interfaces and a jitter attenuator. The transmit interface is responsible for generating the necessary waveshapes for driving the network and providing the correct source impedance depending on the type of media used. T1 waveform generation includes DSX-1 line build-outs as well as CSU line build-outs of -7.5dB, -15dB, and -22.5dB. E1 waveform generation includes G.703 waveshapes for both 75Ω coax and 120Ω twisted cables. The receive interface provides network termination and recovers clock and data from the network. The receive sensitivity adjusts automatically to the incoming signal and can be programmed for 0 to 43dB or 0 to 12dB for E1 applications and 0 to 30dB or 0 to 36dB for T1 applications. The jitter attenuator removes phase jitter from the transmitted or received signal. The crystal-less jitter attenuator requires only a 2.048MHz MCLK for both E1 and T1 applications (with the option of using a 1.544MHz MCLK in T1 applications) and can be placed in either transmit or receive data paths. An additional feature of the LIU is a CMI coder/decoder for interfacing to optical networks.

On the transmit side, clock, data, and frame-sync signals are provided to the framer by the backplane interface section. The framer inserts the appropriate synchronization framing patterns, alarm information, calculates and inserts the CRC codes, and provides the B8ZS/HDB3 (zero code suppression) and AMI line coding. The receive-side framer decodes AMI, B8ZS, and HDB3 line coding, synchronizes to the data stream, reports alarm information, counts framing/coding/CRC errors, and provides clock/data and frame-sync signals to the backplane interface section. Diagnostic capabilities include loopbacks, PRBS pattern generation/detection, and 16-bit loop-up and loop-down code generation and detection.

Both the transmit and receive path have two HDLC controllers. The HDLC controllers transmit and receive data through the framer block. The HDLC controllers can be assigned to any time slot, group of time slots, portion of a time slot or to FDL (T1) or Sa bits (E1). Each controller has 128-byte FIFOs, thus reducing the amount of processor overhead required to manage the flow of data. In addition, built-in support for reducing the processor time is required in SS7 applications.

The backplane interface provides a versatile method of sending and receiving data from the host system. Elastic stores provide a method for interfacing to asynchronous systems, converting from a T1/E1 network to a 2.048MHz, 4.096MHz, 8.192MHz, or N x 64kHz system backplane. The elastic stores also manage slip conditions (asynchronous interface).

An 8-bit parallel microcontroller port provides access for control and configuration of all the features of the device. The internal 100MHz SDRAM controller interfaces to a 32-bit wide 128Mb SDRAM. The SDRAM is used to buffer the data from the Ethernet and WAN ports for transport. The external SDRAM can accommodate up to 8192 frames with a maximum frame size of 2016 bytes. Diagnostic capabilities include SDRAM BIST, loopbacks, PRBS pattern generation/detection, and 16-bit loop-up and loop-down code generation and detection. The DS33R11 operates with a 1.8V core supply and 3.3V I/O supply.

The integrated Ethernet Mapper is software compatible with the DS33Z11 Ethernet mapper. There are a few things to note when porting a DS33Z11 application to this device:

- The SPI and hardware modes are not supported.
- RSER has been renamed to RSERI.
- RCLK has been renamed to RCLKI.
- TSER has been renamed to TSERO.
- TCLK has been renamed to TCLKE.

The integrated T1/E1/J1 transceiver is software compatible with the DS2155 T1/E1/J1 transceiver. There are a few things to note when porting a DS2155 application to this device:

- The Facilities Data Link (FDL) support is available through software only. The TLINK, RLINK, TLCLK, RLCLK pins are not available on the DS33R11.
- Multiplexed Microprocessor Bus mode is not supported on the DS33R11.
- The Extended System Information Bus (ESIB) is not supported on the DS33R11.
- The MODEC pins serve the function of the DS2155's BTS pin.
- The interim LIU/Framer clock signals RCLKI, RCLKO have been renamed to RDCLKI, RDCLKO to avoid confusion with the receive clock connections between the transceiver and the Ethernet mapper.
- The interim LIU/Framer clock signals TCLKI, TCLKO have been renamed to TDCLKI, TDCLKO to avoid confusion with the receive clock connections between the transceiver and the Ethernet mapper.
- RSER has been renamed RSERO.
- RCLK has been renamed RCLKO.
- TSER has been renamed TSERI.
- TCLK has been renamed TCLKT.

2 FEATURE HIGHLIGHTS

2.1 General

- 256-pin, 27mm BGA package
- 1.8V and 3.3V supplies
- IEEE 1149.1 JTAG boundary scan
- Software access to device ID and silicon revision
- Development support includes evaluation kit, driver source code, and reference designs
- Reference design routes on a two-layer PC board
- Programmable output clocks for fractional T1, E1, H0, and H12 applications

2.2 Microprocessor Interface

- Parallel control port with 8-bit data bus
- Nonmultiplexed Intel and Motorola timing modes
- Internal software reset and external hardware reset-input pin
- Supports polled or interrupt-driven environments
- Software access to device ID and silicon revision
- Global interrupt-output pin

2.3 HDLC Ethernet Mapping

- Dedicated HDLC controller engine for protocol encapsulation
- Compatible with polled or interrupt driven environments
- Programmable FCS insertion and extraction
- Programmable FCS type
- Supports FCS error insertion
- Programmable packet size limits (Minimum 64 bytes and maximum 2016 bytes)
- Supports bit stuffing/destuffing
- Selectable packet scrambling/descrambling ($X^{43}+1$)
- Separate FCS errored packet and aborted packet counts
- Programmable inter-frame fill for transmit HDLC

2.4 X.86 (Link Access Protocol for SONET/SDH) Ethernet Mapping

- Programmable X.86 address/control fields for transmit and receive
- Programmable 2-byte protocol (SAPI) field for transmit and receive
- 32 bit FCS
- Transmit transparency processing—7E is replaced by 7D, 5E
- Transmit transparency processing—7D replaced by 7D, 5D
- Receive rate adaptation (7D, DD) is deleted.
- Receive transparency processing—7D, 5E is replaced by 7E
- Receive transparency processing—7D, 5D is replaced by 7D
- Receive abort sequence the LAPS packet is dropped if 7D7E is detect
- Self-synchronizing $X^{43}+1$ payload scrambling.
- Frame indication due to bad address/control/SAPI, FCS error, abort sequence or frame size longer than preset max

2.5 Additional HDLC Controllers in the Integrated T1/E1/J1 Transceiver

- Two additional independent HDLC controllers
- Fast load and unload features for FIFOs
- SS7 support for FISU transmit and receive
- Independent 128-byte Rx and Tx buffers with interrupt support
- Access FDL, Sa, or single/multiple DS0 channels
- DS0 access includes Nx64 or Nx56
- Compatible with polled or interrupt driven environments
- Bit-oriented code (BOC) support

2.6 Committed Information Rate (CIR) Controller

- CIR Rate controller limits transmission of data from the Ethernet interface to the serial interface
- CIR granularity at 512kbit/s
- CIR averaging for smoothing traffic peaks

2.7 SDRAM Interface

- Interface for 128Mb, 32-bit-wide SDRAM
- SDRAM Interface speed up to 100MHz
- Auto refresh timing
- Automatic precharge
- Master clock provided to the SDRAM
- No external components required for SDRAM connectivity

2.8 MAC Interface

- MAC port with standard MII (less TX_ER) or RMII
- 10Mbps and 100Mbps Data rates
- Configurable DTE or DCE modes
- Facilitates auto-negotiation by host microprocessor
- Programmable half and full-duplex modes
- Flow control for both half-duplex (back-pressure) and full-duplex (PAUSE) modes
- Programmable Maximum MAC frame size up to 2016 bytes
- Minimum MAC frame size: 64 bytes
- Discards frames greater than programmed maximum MAC frame size and runt, nonoctet bounded, or bad-FCS frames upon reception
- Configurable for promiscuous broadcast-discard mode.
- Programmable threshold for SDRAM queues to initiate flow control and status indication
- MAC loopback support for transmit data looped to receive data at the MII/RMII interface

2.9 T1/E1/J1 Line Interface

- Requires only a 2.048MHz master clock for both E1 and T1 operation with the option to use 1.544MHz for T1 operation
- Fully software configurable
- Short-haul and long-haul applications
- Automatic receive sensitivity adjustments
- Ranges include 0 to 43dB or 0 to 12dB for E1 applications and 0 to 13dB or 0 to 36dB for T1 applications
- Receive level indication in 2.5dB steps from -42.5dB to -2.5dB
- Internal receive termination option for 75 Ω , 100 Ω , and 120 Ω lines
- Internal transmit termination option for 75 Ω , 100 Ω , and 120 Ω lines
- Monitor application gain settings of 20dB, 26dB, and 32dB
- G.703 receive synchronization-signal mode
- Flexible transmit waveform generation
- T1 DSX-1 line build-outs
- T1 CSU line build-outs of -7.5dB, -15dB, and -22.5dB
- E1 waveforms include G.703 waveshapes for both 75 Ω coax and 120 Ω twisted cables
- AIS generation independent of loopbacks
- Alternating ones and zeros generation
- Square-wave output
- Open-drain output option
- NRZ format option
- Transmitter power-down
- Transmitter 50mA short-circuit limiter with current-limit-exceeded indication
- Transmit open-circuit-detected indication
- Line interface function can be completely decoupled from the framer/formatter

2.10 Clock Synthesizer

- Output frequencies include 2.048MHz, 4.096MHz, 8.192MHz, and 16.384MHz
- Derived from recovered receive clock

2.11 Jitter Attenuator

- 32-bit or 128-bit crystal-less jitter attenuator
- Requires only a 2.048MHz master clock for both E1 and T1 operation with the option to use 1.544MHz for T1 operation
- Can be placed in either the receive or transmit path or disabled
- Limit trip indication

2.12 T1/E1/J1 Framer

- Fully independent transmit and receive functionality
- Full receive and transmit path transparency
- T1 framing formats include D4 (SLC-96) and ESF
- Detailed alarm and status reporting with optional interrupt support
- Large path and line error counters for:
 - T1: BPV, CV, CRC6, and framing bit errors
 - E1: BPV, CV, CRC4, E-bit, and frame alignment errors
- Timed or manual update modes
- DS1 idle code generation on a per-channel basis in both transmit and receive paths
 - User-defined
 - Digital milliwatt
- ANSI T1.403-1998 Support
- RAI-CI detection and generation
- AIS-CI detection and generation
- E1 ETS 300 011 RAI generation
- G.965 V5.2 link detect
- Ability to monitor one DS0 channel in both the transmit and receive paths
- In-band repeating pattern generators and detectors
 - Three independent generators and detectors
 - Patterns from 1 to 8 bits or 16 bits in length
- RCL, RLOS, RRA, and RAIS alarms interrupt on change-of-state
- Flexible signaling support
 - Software or hardware based
 - Interrupt generated on change of signaling data
 - Receive signaling freeze on loss-of-sync, carrier loss, or frame slip
- Addition of hardware pins to indicate carrier loss and signaling freeze
- Automatic RAI generation to ETS 300 011 specifications
- Access to Sa and Si bits
- Option to extend carrier loss criteria to a 1ms period as per ETS 300 233
- Japanese J1 support
 - Ability to calculate and check CRC6 according to the Japanese standard
 - Ability to generate Yellow Alarm according to the Japanese standard

2.13 TDM Bus

- Dual two-frame independent receive and transmit elastic stores
 - Independent control and clocking
 - Controlled slip capability with status
 - Minimum delay mode supported
- Programmable output clocks for fractional T1, E1, H0, and H12 applications
- Hardware signaling capability
 - Receive signaling reinsertion to a backplane multiframe sync
 - Availability of signaling in a separate PCM data stream
 - Signaling freezing
- Ability to pass the T1 F-bit position through the elastic stores in the 2.048MHz backplane mode
- Access to the data streams in between the framer/formatter and the elastic stores
- User-selectable synthesized clock output

2.14 Test and Diagnostics

- IEEE 1149.1 support
- Programmable on-chip bit error-rate tester (BERT)
- Pseudorandom patterns including QRSS
- User-defined repetitive patterns
- Daly pattern
- Error insertion single and continuous
- Total bit and errored bit counts
- Payload error insertion
- Error insertion in the payload portion of the T1 frame in the transmit path
- Errors can be inserted over the entire frame or selected channels
- Insertion options include continuous and absolute number with selectable insertion rates
- F-bit corruption for line testing
- Loopbacks: remote, local, analog, and per-channel loopback

2.15 Specifications Compliance

The DS33R11 meets relevant telecommunications specifications. The following table provides the specifications and relevant sections that are applicable to the DS33R11.

Table 2-1. T1-Related Telecommunications Specifications

IEEE 802.3-2002—CSMA/CD access method and physical layer specifications.
RFC1662—PPP in HDLC-like Framing
RFC2615—PPP over SONET/SDH
X.86—Ethernet over LAPS
RMII—Industry Implementation Agreement for “Reduced MII Interface,” Sept 1997
ANSI: T1.403-1995, T1.231–1993, T1.408
AT&T: TR54016, TR62411
ITU-T: G.703, G.704, G.706, G.736, G.775, G.823, G.932, I.431, O.151, Q.161, Recommendation I.432–03/93 B-ISDN User-Network Interface—Physical Layer Specification
ETSI: ETS 300 011, ETS 300 166, ETS 300 233, CTR12, CTR4
Japanese: JTG.703, JTI.431, JJ-20.11 (CMI Coding Only)

3 APPLICATIONS

The DS33R11 is ideal for application areas such as transparent LAN service, LAN extension, and Ethernet delivery over T1/E1/J1, T3/E3, OC-1/EC-1, G.SHDSL, or HDSL2/4.

For an example of a complete LAN-to-WAN design, refer to *Application Note 3411: DS33Z11—Ethernet LAN to Unframed T1/E1 WAN Bridge*, available on our website at www.maxim-ic.com/telecom.

Figure 3-1. Ethernet-to-WAN Extension (With or Without Framing)

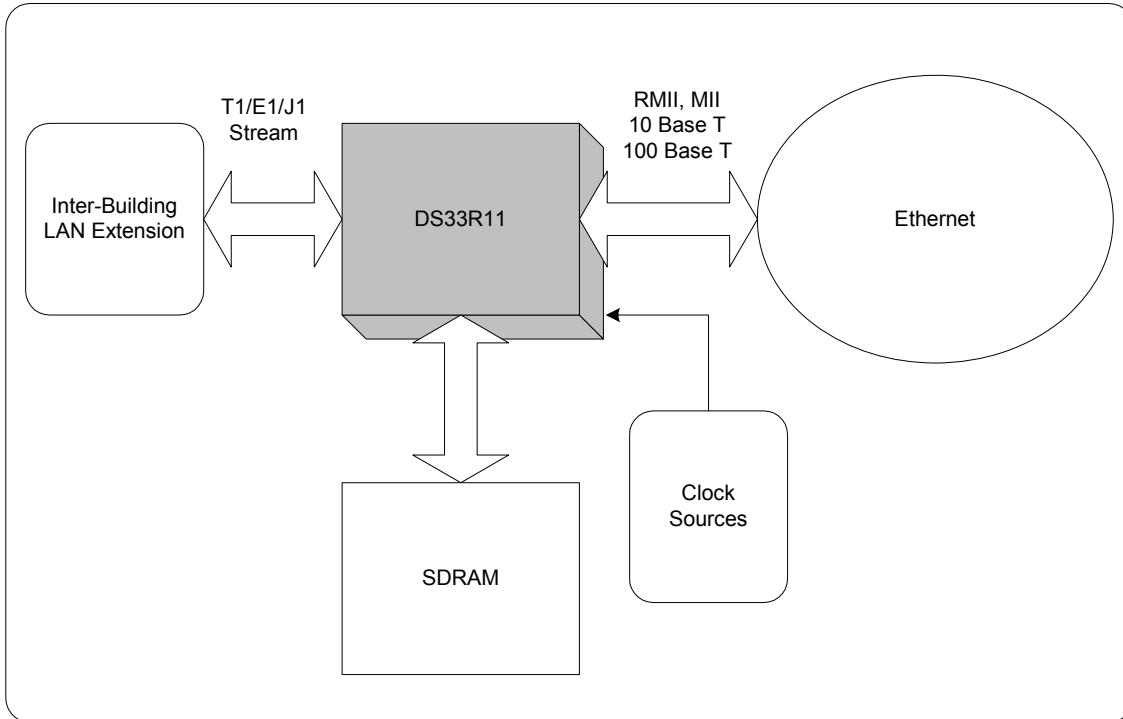

4 ACRONYMS AND GLOSSARY

- BERT: Bit Error-Rate Tester
- DCE: Data Communication Interface
- DTE: Data Terminating Interface
- FCS: Frame Check Sequence
- HDLC: High-Level Data Link Control
- MAC: Media Access Control
- MII: Media Independent Interface
- RMII: Reduced Media Independent Interface
- WAN: Wide Area Network

Note 1: Previous versions of this document used the term “Subscriber” to refer to the Ethernet Interface function. The register names have been allowed to remain with a “SU.” prefix to avoid register renaming.

Note 2: Previous versions of this document used the term “Line” to refer to the Serial Interface. The register names have been allowed to remain with a “LI.” prefix to avoid register renaming.

Note 3: The terms “Transmit Queue” and “Receive Queue” are with respect to the Ethernet Interface. The Receive Queue is the queue for the data that arrives on the MII/RMII interface, is processed by the MAC and stored in the SDRAM. Transmit queue is for data that arrives from the Serial port, is processed by the HDLC and stored in the SDRAM to be sent to the MAC transmitter.

Note 4: This data sheet assumes a particular nomenclature of the T1 operating environment. In each 125 μ s frame there are 24 8-bit channels plus a framing bit. It is assumed that the framing bit is sent first followed by channel 1. Each channel is made up of eight bits that are numbered 1 to 8. Bit number 1 is the MSB and is transmitted first. Bit number 8 is the LSB and is transmitted last. The term “locked” is used to refer to two clock signals that are phase- or frequency-locked or derived from a common clock (i.e., a 1.544MHz clock can be locked to a 2.048MHz clock if they share the same 8kHz component). Throughout this data sheet, the following abbreviations are used:

B8ZS	Bipolar with 8 Zero Substitution
BOC	Bit-Oriented Code
CRC	Cyclical Redundancy Check
D4	Superframe (12 frames per multiframe) Multiframe Structure
ESF	Extended Superframe (24 frames per multiframe) Multiframe Structure
FDL	Facility Data Link
FPS	Framing Pattern Sequence in ESF
Fs	Signaling Framing Pattern in D4
Ft	Terminal Framing Pattern in D4
HDLC	High-Level Data Link Control
MF	Multiframe
SLC-96	Subscriber Loop Carrier—96 Channels

5 MAJOR OPERATING MODES

Microprocessor control is possible through the 8-bit parallel control port and provides configuration for all the features of the device. The Ethernet Link Transport Engine in the device can be configured for HDLC or X.86 encapsulation.

The integrated transceiver can be software configured for T1, E1, or J1 operation. It is composed of a line interface unit (LIU), framer, two additional HDLC controllers, and a TDM backplane interface, and is controlled via an 8-bit parallel port configured for Intel or Motorola bus operations.

The LIUs are composed of a transmit interface, receive interface, and a jitter attenuator. The transmit interface is responsible for generating the necessary waveshapes for driving the network and providing the correct source impedance depending on the type of media used. T1 waveform generation includes DSX-1 line build-outs as well as CSU line build-outs of -7.5dB, -15dB, and -22.5dB. E1 waveform generation includes G.703 waveshapes for both 75 Ω coax and 120 Ω twisted cables. The receive interface provides network termination and recovers clock and data from the network. The receive sensitivity adjusts automatically to the incoming signal and can be programmed for 0dB to 43dB or 0dB to 12dB for E1 applications and 0dB to 15dB or 0dB to 36dB for T1 applications. The jitter attenuator removes phase jitter from the transmitted or received signal. The crystal-less jitter attenuator requires only a 2.048MHz MCLK for both E1 and T1 applications (with the option of using a 1.544MHz MCLK in T1 applications) and can be placed in either transmit or receive data paths.

More information on microprocessor control is available in Section [8.1](#).

6 BLOCK DIAGRAMS

Figure 6-1. Main Block Diagram

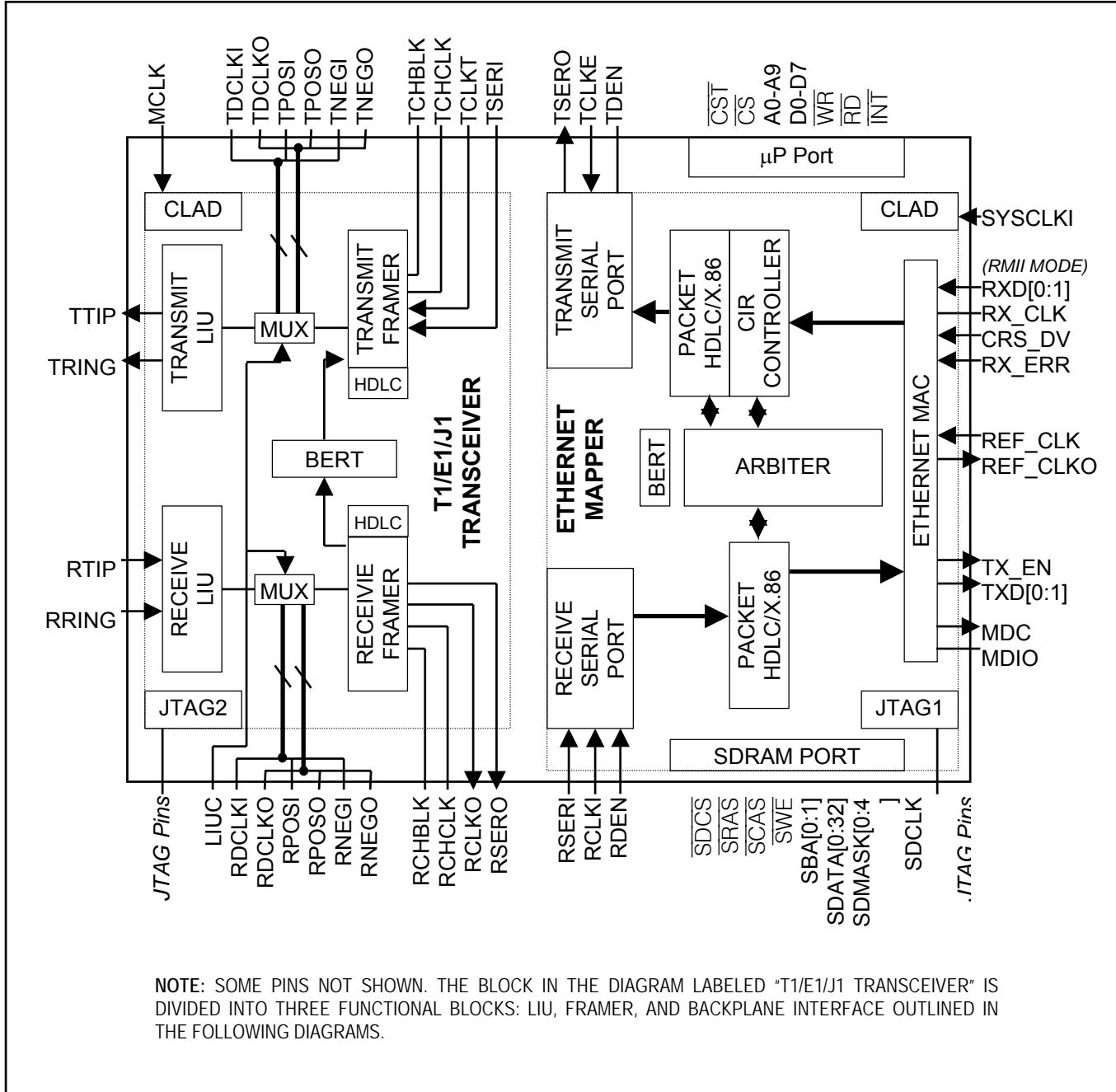

Figure 6-2. Block Diagram of T1/E1/J1 Transceiver

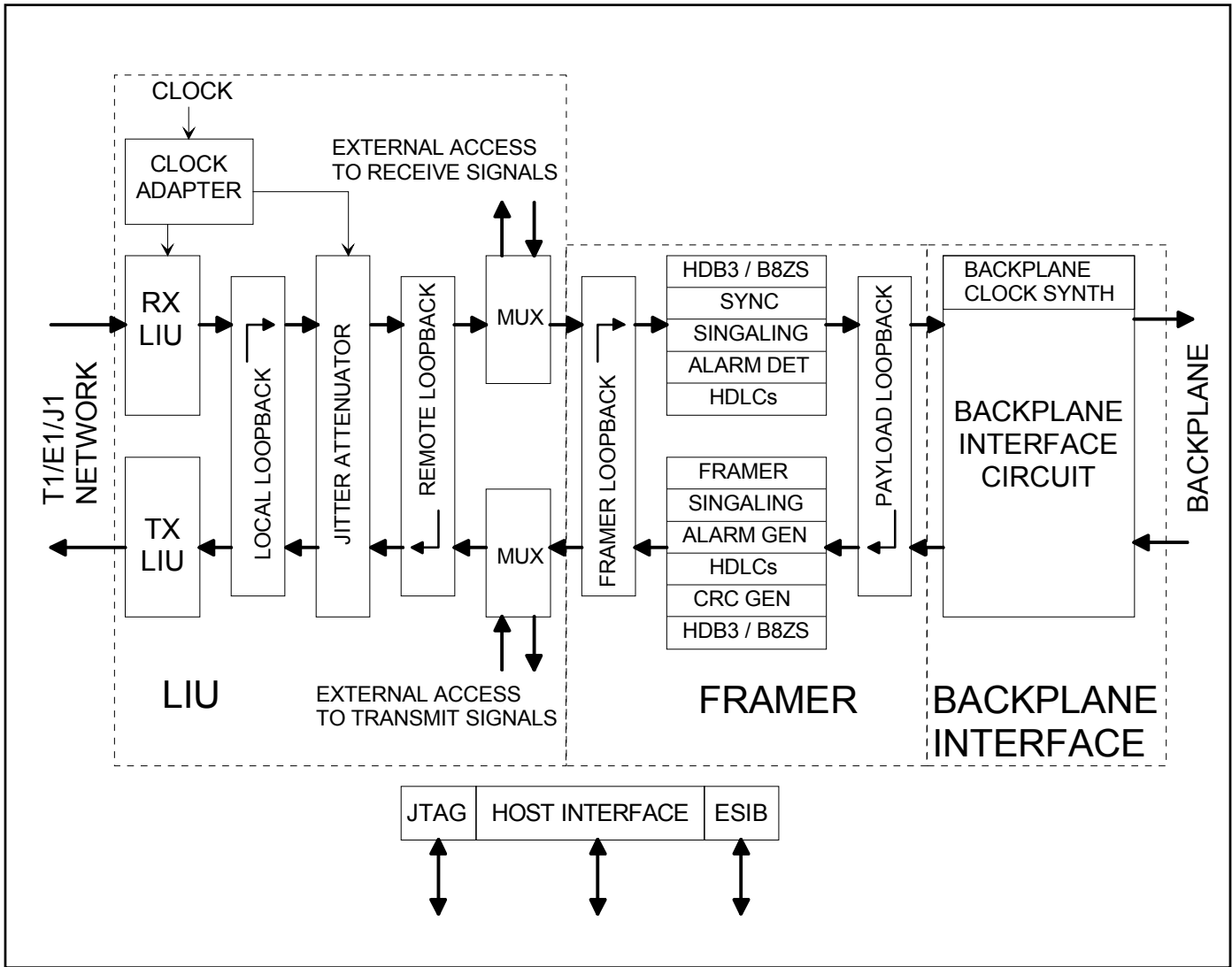

Figure 6-3. Receive and Transmit T1/E1/J1 LIU

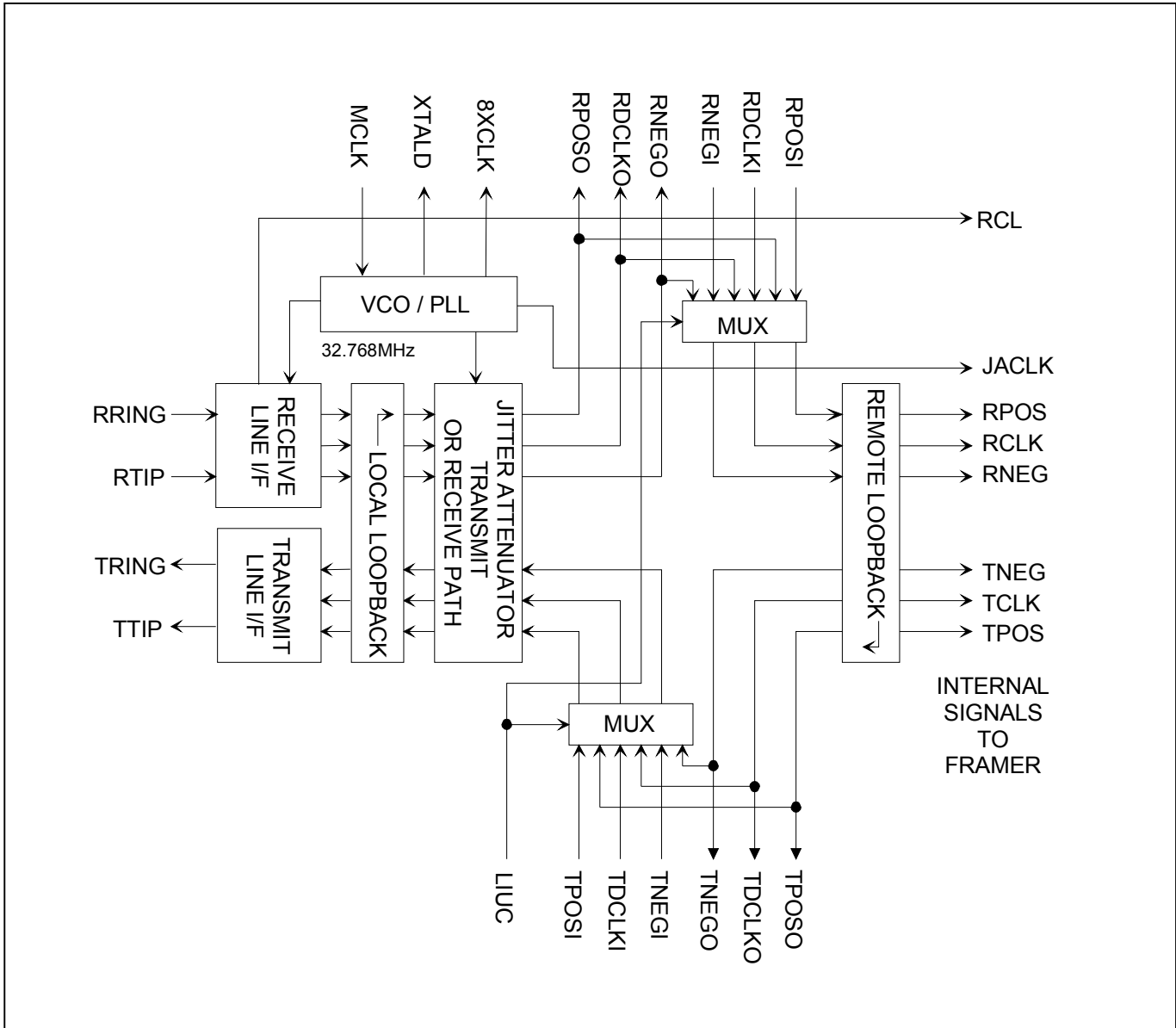

Figure 6-4. Receive and Transmit T1/E1/J1 Framer

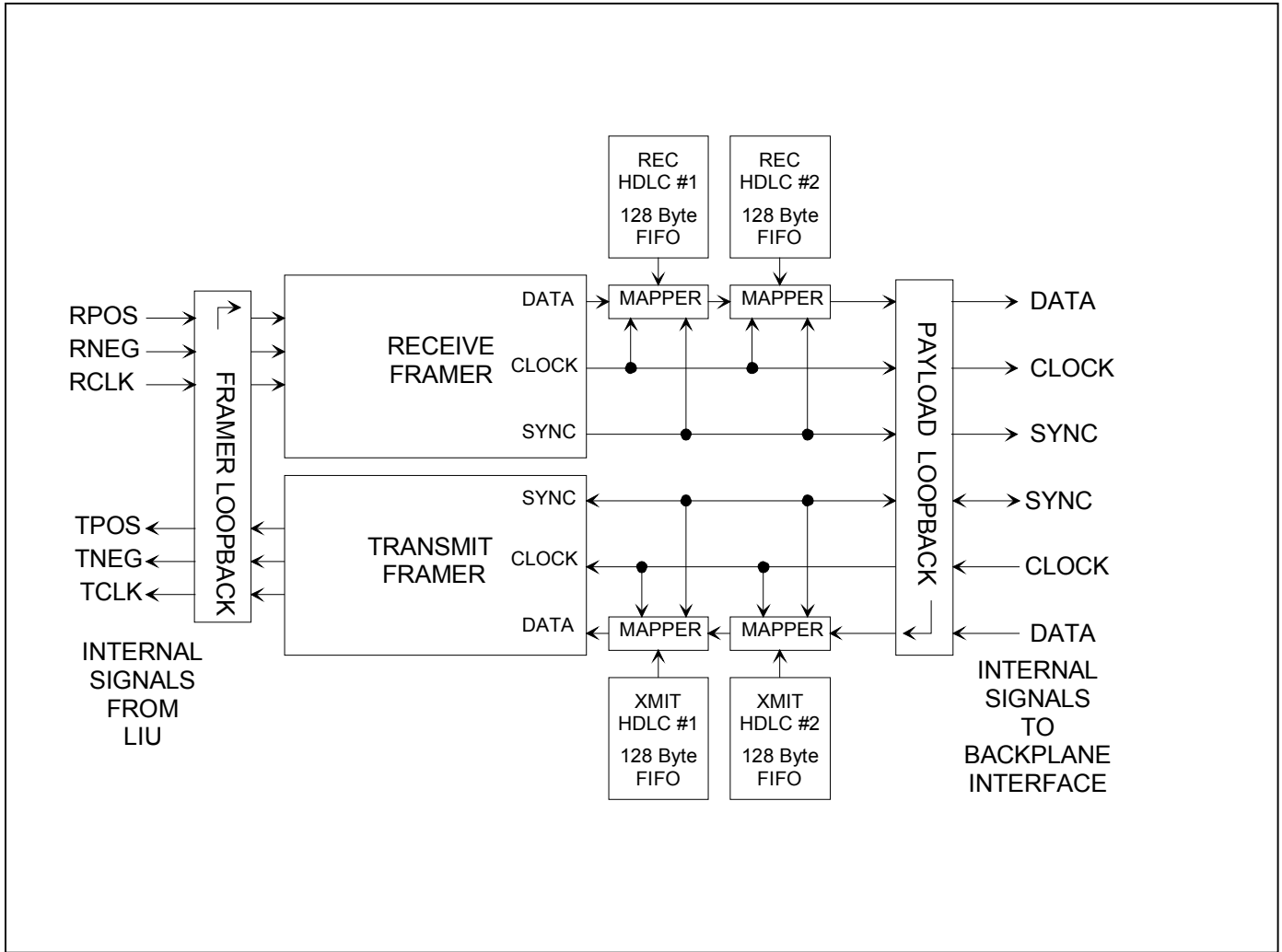
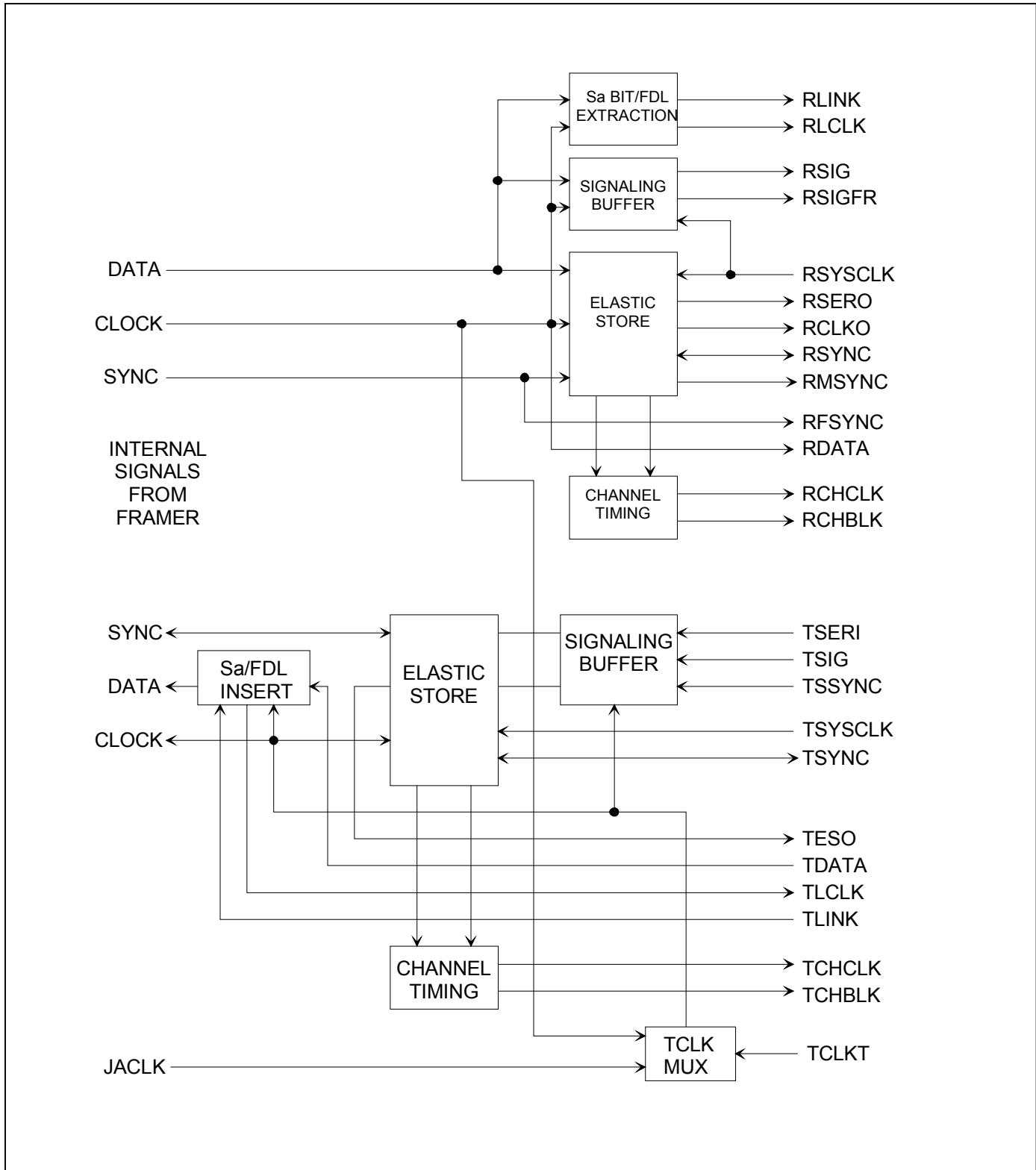

Figure 6-5. T1/E1/J1 Backplane Interface



7 PIN DESCRIPTIONS

7.1 Pin Functional Description

Note that all digital pins are IO pins in JTAG mode. This feature increases the effectiveness of board level ATPG patterns.

LEGEND: I = input, O = output, Ipu = input with pullup, Oz = output with tri-state, IO = bidirectional pin, IOz = bidirectional pin with tri-state.

Table 7-1. Detailed Pin Descriptions

NAME	PIN	TYPE	FUNCTION
MICROPROCESSOR PORT			
A0	A18	I	Address Bit 0: Address bit 0 of the microprocessor interface. Least Significant Bit.
A1	B18	I	Address Bit 1: Address bit 1 of the microprocessor interface.
A2	C18	I	Address Bit 2: Address bit 2 of the microprocessor interface.
A3	A17	I	Address Bit 3: Address bit 3 of the microprocessor interface.
A4	B17	I	Address Bit 4: Address bit 4 of the microprocessor interface.
A5	C17	I	Address Bit 5: Address bit 5 of the microprocessor interface.
A6	A16	I	Address Bit 6: Address bit 6 of the microprocessor interface.
A7	B16	I	Address Bit 7: Address bit 7 of the microprocessor interface.
A8	C16	I	Address Bit 8: Address bit 8 of the microprocessor interface.
A9	C15	I	Address Bit 9: Address bit 9 of the microprocessor interface.
D0	A14	IOZ	Data Bit 0: Bidirectional data bit 0 of the microprocessor interface. Least Significant Bit. Not driven when $\overline{CS} = 1$ or $\overline{RST} = 0$.
D1	B14	IOZ	Data Bit 1: Bidirectional data bit 1 of the microprocessor interface. Not driven when $\overline{CS} = 1$ or $\overline{RST} = 0$.
D2	C14	IOZ	Data Bit 2: Bidirectional data bit 2 of the microprocessor interface. Not driven when $\overline{CS} = 1$ or $\overline{RST} = 0$.
D3	A13	IOZ	Data Bit 3: Bidirectional data bit 3 of the microprocessor interface. Not driven when $\overline{CS} = 1$ or $\overline{RST} = 0$.
D4	B13	IOZ	Data Bit 4: Bidirectional data bit 4 of the microprocessor interface. Not driven when $\overline{CS} = 1$ or $\overline{RST} = 0$.
D5	C13	IOZ	Data Bit 5: Bidirectional data bit 5 of the microprocessor interface. Not driven when $\overline{CS} = 1$ or $\overline{RST} = 0$.
D6	A12	IOZ	Data Bit 6: Bidirectional data bit 6 of the microprocessor interface. Not driven when $\overline{CS} = 1$ or $\overline{RST} = 0$.
D7	B12	IOZ	Data Bit 7: Bidirectional data bit 7 of the microprocessor interface. Most Significant Bit. Not driven when $\overline{CS} = 1$ or $\overline{RST} = 0$.
$\overline{WR}/\overline{RW}$	C11	I	<p>Write (Intel Mode): The DS33R11 captures the contents of the data bus (D0-D7) on the rising edge of \overline{WR} and writes them to the addressed register location. \overline{CS} must be held low during write operations.</p> <p>Read Write (Motorola Mode): Used to indicate read or write operation. \overline{RW} must be set high for a register read cycle and low for a register write cycle.</p>

NAME	PIN	TYPE	FUNCTION
$\overline{RD/DS}$	B11	I	<p>Read Data Strobe (Intel Mode): The DS33R11 drives the data bus (D0-D7) with the contents of the addressed register while \overline{RD} and \overline{CS} are both low.</p> <p>Data Strobe (Motorola Mode): Used to latch data through the microprocessor interface. \overline{DS} must be low during read and write operations.</p>
\overline{CS}	A11	I	<p>Chip Select for Protocol Conversion Device: This pin must be taken low for read/write operations. When \overline{CS} is high, the $\overline{RD/DS}$ and \overline{WR} signals are ignored.</p>
\overline{CST}	D7	I	<p>Chip Select for the T1/E1/J1 Transceiver: Must be low to read or write the T1/E1/J1 transceiver.</p>
\overline{INT}	A10	OZ	<p>Interrupt Output: Outputs a logic zero when an unmasked interrupt event is detected. \overline{INT} is deasserted when all interrupts have been acknowledged and serviced. Active low. Inactive state is programmable in register GL.CR1. is deasserted when all interrupts have been acknowledged and serviced. Active low. Inactive state is programmable in register GL.CR1.</p>

NAME	PIN	TYPE	FUNCTION
MII/RMII PHY PORT			
COL_DET	N18	O	Collision Detect (MII): Asserted by the MAC PHY to indicate that a collision is occurring. In DCE Mode this signal should be connected to ground. This signal is only valid in half duplex mode, and is ignored in full duplex mode.
RX_CRS/ CRS_DV	M19	I	Receive Carrier Sense (MII): Should be asserted (high) when data from the PHY (RXD[3:0]) is valid. For each clock pulse 4 bits arrive from the PHY. Bit 0 is the least significant bit. In DCE mode, connect to V _{DD} . Carrier Sense/Receive Data Valid (RMII): This signal is asserted (high) when data is valid from the PHY. For each clock pulse 2 bits arrive from the PHY. In DCE mode, this signal must be grounded.
RX_CLK	M20	IO	Receive Clock (MII): Timing reference for RX_DV, RX_ERR and RXD[3:0], which are clocked on the rising edge. RX_CLK frequency is 25MHz for 100Mbit/s operation and 2.5MHz for 10Mbit/s operation. In DTE mode, this is a clock input provided by the PHY. In DCE mode, this is an output derived from REF_CLK providing 2.5MHz (10Mbit/s operation) or 25MHz (100Mbit/s operation).
RXD[0]	L18	O	Receive Data 0 through 3 (MII): Four bits of received data, sampled synchronously with the rising edge of RX_CLK. For every clock cycle, the PHY transfers 4 bits to the DS33R11. RXD[0] is the least significant bit of the data. Data is not considered valid when RX_DV is low. Receive Data 0 through 1 (RMII): Two bits of received data, sampled synchronously with REF_CLK with 100Mbit/s mode. Accepted when CRS_DV is asserted. When configured for 10Mbit/s mode, the data is sampled once every 10 clock periods.
RXD[1]	L19		
RXD[2]	L20		
RXD[3]	M18		
RX_DV	K19	I	Receive Data Valid (MII): This active high signal indicates valid data from the PHY. The data RXD is ignored if RX_DV is not asserted high.
RX_ERR	K18	I	Receive Error (MII): Asserted by the MAC PHY for one or more RX_CLK periods indicating that an error has occurred. Active High indicates Receive code group is invalid. If CRS_DV is low, RX_ERR has no effect. This is synchronous with RX_CLK. In DCE mode, this signal must be grounded. Receive Error (RMII): Signal is synchronous to REF_CLK.
TX_CLK	H19	IO	Transmit Clock (MII): Timing reference for TX_EN and TXD[3:0]. The TX_CLK frequency is 25MHz for 100Mbit/s operation and 2.5MHz for 10Mbit/s operation. In DTE mode, this is a clock input provided by the PHY. In DCE mode, this is an output derived from REF_CLK providing 2.5MHz (10Mbit/s operation) or 25MHz (100Mbit/s operation).

NAME	PIN	TYPE	FUNCTION
TXD[0]	F19	O	<p>Transmit Data 0 through 3(MII): TXD [3:0] is presented synchronously with the rising edge of TX_CLK. TXD [0] is the least significant bit of the data. When TX_EN is low the data on TXD should be ignored.</p> <p>Transmit Data 0 through 1(RMII): Two bits of data TXD [1:0] presented synchronously with the rising edge of REF_CLK.</p>
TXD[1]	F18		
TXD[2]	E20		
TXD[3]	E19		
TX_EN	F20	O	<p>Transmit Enable (MII): This pin is asserted high when data TXD [3:0] is being provided by the DS33R11. The signal is deasserted prior to the first nibble of the next frame. This signal is synchronous with the rising edge TX_CLK. It is asserted with the first bit of the preamble.</p> <p>Transmit Enable (RMII): When this signal is asserted, the data on TXD [1:0] is valid. This signal is synchronous to the REF_CLK.</p>
REF_CLK	A19	I	<p>Reference Clock (RMII and MII): When in RMII mode, all signals from the PHY are synchronous to this clock input for both transmit and receive. This required clock can be up to 50MHz and should have ± 100ppm accuracy.</p> <p>When in MII mode in DCE operation, the DS33R11 uses this input to generate the RX_CLK and TX_CLK outputs as required for the Ethernet PHY interface. When the MII interface is used with DTE operation, this clock is not required and should be tied low.</p> <p>In DCE and RMII modes, this input must have a stable clock input before setting the $\overline{\text{RST}}$ pin high for normal operation.</p>
REF_CLKO	A20	O	<p>Reference Clock Output (RMII and MII): A derived clock output up to 50MHz, generated by internal division of the SYSCLKI signal. Frequency accuracy of the REF_CLKO signal will be proportional to the accuracy of the user-supplied SYSCLKI signal. See Section 9.1.1 for more information.</p>
DCEDTES	G20	I	<p>DCE or DTE Selection: The user must set this pin high for DCE Mode selection or low for DTE Mode. In DCE Mode, the DS33R11 MAC port can be directly connected to another MAC. In DCE Mode, the Transmit clock (TX_CLK) and Receive clock (RX_CLK) are output by the DS33R11. Note that there is no software bit selection of DCEDTES. Note that DCE Mode is only relevant when the MAC interface is in MII mode.</p>
RMIIMIIS	G19	I	<p>RMII or MII Selection: Set high to configure the MAC for RMII interfacing. Set low for MII interfacing.</p>

NAME	PIN	TYPE	FUNCTION
PHY MANAGEMENT BUS			
MDC	C19	O	Management Data Clock (MII): Clocks management data between the PHY and DS33R11. The clock is derived from the SYSCLKI, with a maximum frequency is 1.67MHz. The user must leave this pin unconnected in the DCE Mode.
MDIO	C20	IO	MII Management data IO (MII): Data path for control information between the PHY and DS33R11. When not used, pull to logic high externally through a 10kΩ resistor. The MDC and MDIO pins are used to write or read up to 32 Control and Status Registers in 32 PHY Controllers. This port can also be used to initiate Auto-Negotiation for the PHY. The user must leave this pin unconnected in the DCE Mode.
SDRAM INTERFACE			
$\overline{\text{SCAS}}$	W7	O	SDRAM Column Address Strobe: Active-low output, used to latch the column address on the rising edge of SDCLKO. It is used with commands for Bank Activate, Precharge, and Mode Register Write.
$\overline{\text{SRAS}}$	W9	O	SDRAM Row Address Strobe: Active-low output, used to latch the row address on rising edge of SDCLKO. It is used with commands for Bank Activate, Precharge, and Mode Register Write.
$\overline{\text{SDCS}}$	V10	O	SDRAM Chip Select: Active-low output enables SDRAM access.
$\overline{\text{SWE}}$	W10	O	SDRAM Write Enable: This active-low output enables write operation and auto precharge.
SBA[0]	Y11	O	SDRAM Bank Select: These 2 bits select 1 of 4 banks for the read/write/precharge operations. Note: All SDRAM operations are controlled entirely by the DS33R11. No user programming for SDRAM buffering is required.
SBA[1]	V11		

NAME	PIN	TYPE	FUNCTION
SDATA[0]	W2	O	<p>SDRAM Data Bus Bits 0 to 31: The 32 pins of the SDRAM data bus are inputs for read operations and outputs for write operations. At all other times, these pins are high-impedance.</p> <p>Note: All SDRAM operations are controlled entirely by the DS33R11. No user programming for SDRAM buffering is required.</p>
SDATA[1]	Y4		
SDATA[2]	Y2		
SDATA[3]	Y5		
SDATA[4]	Y3		
SDATA[5]	W5		
SDATA[6]	V5		
SDATA[7]	W6		
SDATA[8]	V6		
SDATA[9]	W4		
SDATA[10]	V4		
SDATA[11]	V2		
SDATA[12]	V3		
SDATA[13]	V1		
SDATA[14]	W3		
SDATA[15]	W1		
SDATA[16]	Y16		
SDATA[17]	Y17		
SDATA[18]	V18		
SDATA[19]	Y19		
SDATA[20]	V19		
SDATA[21]	Y20		
SDATA[22]	U19		
SDATA[23]	W20		
SDATA[24]	U20		
SDATA[25]	T19		
SDATA[26]	T20		
SDATA[27]	Y18		
SDATA[28]	W19		
SDATA[29]	V17		
SDATA[30]	W17		
SDATA[31]	W16		
SDA[0]	W14	O	<p>SDRAM Address Bus 0 to 11: The 12 pins of the SDRAM address bus output the row address first, followed by the column address. The row address is determined by SDA0 to SDA11 at the rising edge of clock. Column address is determined by SDA0-SDA9 and SDA11 at the rising edge of the clock. SDA10 is used as an auto-precharge signal.</p> <p>Note: All SDRAM operations are controlled entirely by the DS33R11. No user programming for SDRAM buffering is required.</p>
SDA[1]	W12		
SDA[2]	Y15		
SDA[3]	W15		
SDA[4]	Y14		
SDA[5]	V13		
SDA[6]	W13		
SDA[7]	Y12		
SDA[8]	V12		
SDA[9]	Y10		
SDA[10]	V14		
SDA[11]	W11		
SDMASK[0]	Y6	O	<p>SDRAM Mask 0 through 3: When high, a write is done for that byte. The least significant byte is SDATA7 to SDATA0. The most significant byte is SDATA31 to SDATA24.</p>
SDMASK[1]	V7		
SDMASK[2]	V16		
SDMASK[3]	V15		
SDCLKO	Y8	O (4mA)	<p>SDRAM CLK Out: System clock output to the SDRAM. This clock is a buffered version of SYSCLKI.</p>

NAME	PIN	TYPE	FUNCTION
T1/E1/J1 ANALOG LINE INTERFACE			
TTIP	R1, R2	O	Transmit Analog Tip Output for the T1/E1/J1 Transceiver: Analog line-driver outputs. Two connections are provided to improve signal quality. These pins connect via a 1:2 step-up transformer to the network. See Section 10.24 for details.
TRING	T1,T2	O	Transmit Analog Ring Output for the T1/E1/J1 Transceiver: Analog line-driver outputs. Two connections are provided to improve signal quality. These pins connect via a 1:2 step-up transformer to the network. See Section 10.24 for details.
RTIP	K1	I	Receive Analog Tip Input for the T1/E1/J1 Transceiver: Analog input for clock recovery circuitry. These pins connect via a 1:1 transformer to the network. See Section 10.24 for details.
RRING	M1	I	Receive Analog Ring Input for the T1/E1/J1 Transceiver: Analog input for clock recovery circuitry. These pins connect via a 1:1 transformer to the network. See Section 10.24 for details.
T1/E1/J1 TRANSMIT FRAMER INTERFACE			
TSERI	E3	I	Transmit Serial Data Input to the T1/E1/J1 Framer: Transmit NRZ serial data. Sampled on the falling edge of TCLKT when the transmit-side elastic store is disabled. Sampled on the falling edge of TSYCLK when the transmit-side elastic store is enabled.
TCLKT	D2	I	Transmit Clock for the T1/E1/J1 Transceiver: 1.544MHz or a 2.048MHz primary clock. Used to clock data from the TSERI pin through the transmit-side formatter.
TCHBLK	A2	O	Transmit Channel Block for the T1/E1/J1 Transceiver: A user-programmable output that can be forced high or low during any of the channels. Synchronous with TCLKT when the transmit-side elastic store is disabled. Synchronous with TSYCLK when the transmit-side elastic store is enabled. Useful for locating individual channels in drop-and-insert applications, for external per-channel loopback, and for per-channel conditioning.
TCHCLK	G1	O	Transmit Channel Clock for the T1/E1/J1 Transceiver: A 192kHz (T1) or 256kHz (E1) clock that pulses high during the LSB of each channel. Can also be programmed to output a gated transmit-bit clock for fractional T1/E1 applications. Synchronous with TCLKT when the transmit-side elastic store is disabled. Synchronous with TSYCLK when the transmit-side elastic store is enabled. Useful for parallel-to-serial conversion of channel data.
TSSYNC	A5	I	Transmit System Sync for the T1/E1/J1 Transceiver: Only used when the transmit-side elastic store is enabled. A pulse at this pin will establish either frame or multiframe boundaries for the transmit side. Should be tied low in applications that do not use the transmit-side elastic store.
TSYNC	C1	I/O	Transmit Sync for the T1/E1/J1 Transceiver: A pulse at this pin will establish either frame or multiframe boundaries for the transmit side. Can be programmed to output either a frame or multiframe pulse. If this pin is set to output pulses at frame boundaries, it can also be set via TR.IOCR1.3 to output double-wide pulses at signaling frames in T1 mode.
TSYSCLK	E4	I	Transmit System Clock for the T1/E1/J1 Transceiver: 1.544MHz, 2.048MHz, 4.096MHz, 8.192MHz, or 16.384MHz clock. Only used when the transmit-side elastic-store function is enabled. Should be tied low in applications that do not use the transmit-side elastic store.

NAME	PIN	TYPE	FUNCTION
TSIG	B4	I	Transmit Signaling Input for the T1/E1/J1 Transceiver: When enabled, this input will sample signaling bits for insertion into outgoing PCM data stream. Sampled on the falling edge of TCLKT when the transmit-side elastic store is disabled. Sampled on the falling edge of TSYCLK when the transmit-side elastic store is enabled.
ETHERNET MAPPER TRANSMIT SERIAL INTERFACE			
TSERO	E2	O	Transmit Serial Data Output from Ethernet Mapper: Output on the rising edge of TCLKE. Selective clock periods can be skipped for output of TSERO with a gapped clock input on TCLKE. The maximum data rate is 52Mbit/s.
TCLKE	F1	I	Serial Interface Transmit Clock Input to Ethernet Mapper: The clock reference for TSERO, which is output on the rising edge of the clock. TCLKE supports gapped clocking, up to a maximum frequency of 52MHz.
TDEN/ TBSYNC	D5	IO	Transmit Data Enable (Input): The transmit data enable is programmable to selectively block/enable the transmit data. The TDEN signal must occur one clock edge prior to the affected data bit. The active polarity of TDEN is programmable in register LI.TSLCR. It is recommended for both T1/E1 and T3/E3 applications that use gapped clocks. The TDEN signal is provided for interfacing to framers that do not have a gapped clock facility. Transmit Byte Sync (Output): This output can be used by an external Serial to Parallel to convert TSERO stream to byte wide data. This output indicates the last bit of the byte data sent serially on TSERO. This signal is only active in the X.86 Mode.
T1/E1/J1 RECEIVE FRAMER INTERFACE			
RSERO	H2	O	Receive Serial Data for T1/E1/J1 Transceiver: Received NRZ serial data. Updated on rising edges of RCLKO when the receive-side elastic store is disabled. Updated on the rising edges of RSYCLK when the receive-side elastic store is enabled.
RCLKO	G3	O	Receive Clock Output from the T1/E1/J1 Framer: 1.544MHz (T1) or 2.048MHz (E1) clock that is used to clock data through the receive-side framer. Normally connected to the RCLKI input.
RCHBLK	A1	O	Receive Channel Block for the T1/E1/J1 Transceiver: A user-programmable output that can be forced high or low during any of the 24 T1 or 32 E1 channels. Synchronous with RCLKO when the receive-side elastic store is disabled. Synchronous with RSYCLK when the receive-side elastic store is enabled. Also useful for locating individual channels in drop-and-insert applications, for external per-channel loopback, and for per-channel conditioning. See the <i>Channel Blocking Registers</i> section.
RCHCLK	G2	O	Receive Channel Clock for the T1/E1/J1 Transceiver: A 192kHz (T1) or 256kHz (E1) clock that pulses high during the LSB of each channel can also be programmed to output a gated receive-bit clock for fractional T1/E1 applications. Synchronous with RCLKO when the receive-side elastic store is disabled. Synchronous with RSYCLK when the receive-side elastic store is enabled. Useful for parallel-to-serial conversion of channel data.

NAME	PIN	TYPE	FUNCTION
RSYNC	G4	I/O	Receive Sync for the T1/E1/J1 Transceiver: An extracted pulse, one RCLKO wide, is output at this pin, which identifies either frame (TR.IOCR1.5 = 0) or multiframe (TR.IOCR1.5 = 1) boundaries. If set to output-frame boundaries then via TR.IOCR1.6, RSYNC can also be set to output double-wide pulses on signaling frames in T1 mode. If the receive-side elastic store is enabled, then this pin can be enabled to be an input via TR.IOCR1.4 at which a frame or multiframe boundary pulse is applied.
RSYSCLK	F4	I	Receive System Clock for the Transceiver: 1.544MHz, 2.048MHz, 4.096MHz, or 8.192MHz clock. Only used when the receive-side elastic-store function is enabled. Should be tied low in applications that do not use the receive-side elastic store.
RFSYNC	A3	O	Receive Frame Sync (Pre Receive Elastic Store) for T1/E1/J1 Transceiver: An extracted 8kHz pulse, one RCLKO wide, is output at this pin, which identifies frame boundaries.
RMSYNC	U3	O	Receive Multiframe Sync for the T1/E1/J1 Transceiver: An extracted pulse, one RCLKO wide (elastic store disabled) or one RSYSCLK wide (elastic store enabled), is output at this pin, which identifies multiframe boundaries.
RSIG	L3	O	Receive Signaling Output: Outputs signaling bits in a PCM format. Updated on rising edges of RCLKO when the receive-side elastic store is disabled. Updated on the rising edges of RSYSCLK when the receive-side elastic store is enabled.

NAME	PIN	TYPE	FUNCTION
ETHERNET MAPPER RECEIVE SERIAL INTERFACE			
RSERI	H1	I	Receive Serial Data Input to Ethernet Mapper: Receive Serial data arrives on the rising edge of RCLKI. Normally connected to RSERO.
RCLKI	F2	I	Serial Interface Receive Clock Input to the Ethernet Mapper: Reference clock for receive serial data on RSERI. Gapped clocking is supported, up to the maximum RCLKI frequency of 52 MHz.
RDEN/ RBSYNC	P2	I	Receive Data Enable for the Ethernet Mapper: The receive data enable is programmable to block the receive data. The RDEN must be coincident with the RSERI data bit to be blocked or enabled. The active polarity of RDEN is programmable in register LI.RSLCR . It is recommended for both T1/E1 and T3/E3 applications that use gapped clocks. The RDEN signal is provided for interfacing to framers that do not have a gapped clock facility. Receive Byte Synchronization Input: Provides byte synchronization input to X.86 decoder. This signal will go high at the last bit of the byte as it arrives. This signal can occur at maximum rate every 8 bits. Note that as long as the R11 receives one RBSYNC indicator. The X.86 receiver will determine the byte boundary. Hence the R11 does not require a continuous 8 bit sync indicator. A new sync pulse is required if the byte boundary changes.
T1/E1/J1 FRAMER/LIU INTERIM SIGNALS			
RDCLKI	M4	I	Receive Clock Input to the T1/E1/J1 Framer: Clock used to clock data through the receive-side framer. This pin is normally connected to RDCLKO. Can be internally connected to RDCLKO by connecting the LIUC pin high.
RDCLKO	M3	O	Receive Clock Output from the T1/E1/J1 LIU: Buffered recovered clock from the network. This pin is normally connected to RDCLKI.
RNEGI	L4	I	Receive Negative-Data Input: Sampled on the falling edge of RDCLKI for data to be clocked through the receive-side framer. RPOSI and RNEGI can be connected together for an NRZ interface. Can be internally connected to RNEGO by connecting the LIUC pin high.
RNEGO	N2	O	Receive Negative Data Output from the T1/E1/J1 LIU: Updated on the rising edge of RDCLKO with the bipolar data out of the line interface. This pin is normally tied to RNEGI.
RPOSI	J3	I	Receive Positive-Data Input to the T1/E1/J1 Framer: Sampled on the falling edge of RDCLKI for data to be clocked through the receive-side framer. RPOSI and RNEGI can be connected together for an NRZ interface. Can be internally connected to RPOSO by connecting the LIUC pin high.
RPOSO	N3	O	Receive Positive-Data Output from the T1/E1/J1 LIU: Updated on the rising edge of RDCLKO with bipolar data out of the line interface. This pin is normally connected to RPOSI.
RDATA	H3	O	Receive Data from the T1/E1/J1 Framer: Updated on the rising edge of RCLKO with the data out of the receive-side framer, before passing through the Elastic Store.
TDCLKI	D1	I	Serial Interface Transmit Clock Input for the T1/E1/J1 LIU: Line interface transmit clock. This pin is normally tied to TCLKO. Can be internally connected to TCLKO by connecting the LIUC pin high.

NAME	PIN	TYPE	FUNCTION
TDCLKO	C2	O	Transmit Clock Output from the T1/E1/J1 Framer: Buffered clock that is used to clock data through the transmit-side formatter (either TCLKT or RDCLKI). This pin is normally tied to TDCLKI.
TNEGI	C3	I	Transmit Negative-Data Input: Sampled on the falling edge of TDCLKI for data to be transmitted out onto the T1 line. Can be internally connected to TNEGO by connecting the LIUC pin high. TPOSI and TNEGI can be connected together in NRZ applications.
TNEGO	D3	O	Transmit Negative-Data Output: Updated on the rising edge of TCLKO with the bipolar data out of the transmit-side formatter. This pin is normally connected to TNEGI.
TPOSI	B3	I	Transmit Positive-Data Input: Sampled on the falling edge of TDCLKI for data to be transmitted out onto the T1 line. Can be internally connected to TPOSO by connecting the LIUC pin high. TPOSI and TNEGI can be connected together in NRZ applications.
TPOSO	E1	O	Transmit Positive-Data Output: Updated on the rising edge of TCLKO with the bipolar data out of the transmit-side formatter. Can be programmed to source NRZ data by the output data format (TR.IOCR1.0) control bit. This pin is normally connected to TPOSI.
TDATA	A4	I	Transmit Data: Sampled on the falling edge of TCLKT with data to be clocked through the transmit-side formatter. This pin is normally connected to TESO.
TESO	D4	O	Transmit Elastic Store Output: Updated on the rising edge of TCLKT with data out of the transmit-side elastic store whether the elastic store is enabled or not. This pin is normally connected to TDATA.

NAME	PIN	TYPE	FUNCTION
HARDWARE AND STATUS PINS			
LIUC	B2	I	<p>Line Interface Unit Connect: When a logic low is present on this input pin, the T1/E1/J1 Framer and LIU are not internally connected. The line interface circuitry will be separated from the framer/formatter circuitry and the TPOSI, TNEGI, TDCLKI, RPOSI, RNEGI, and RDCLKI input pins will be active.</p> <p>When a logic high is present on this input pin, the T1/E1/J1 Framer is internally connected to the LIU. The TPOSI, TNEGI, TDCLKI, RPOSI, RNEGI, RDCLKI input pins are deactivated. When LIUC is connected high, the TPOSI, TNEGI, TDCLKI, RPOSI, RNEGI, and RDCLKI pins should be tied low.</p>
$\overline{\text{RST}}$	A8	I	<p>Reset for the Ethernet Mapper: An active low signal on this pin resets the internal registers and logic of the protocol conversion device. This pin should remain low until power, SYSCLKI, RX_CLK, and TX_CLK are stable, then set high for normal operation. This input requires a clean edge with a rise time of 25ns or less to properly reset the device.</p>
TSTRST	C4	I	<p>Test/Reset for the T1/E1/J1 Transceiver: A dual-function pin. A zero-to-one transition issues a hardware reset to the transceiver register set. A reset clears all configuration registers. Configuration register contents are set to zero. Leaving TSTRST high will tri-state all output and I/O pins (including the parallel control port). Set low for normal operation. Useful in board-level testing.</p>
MODEC[0], MODEC[1]	B19, B20	I	<p>Mode Control for Processor Interface: 00 = Read/Write Strobe Used (Intel Mode) 01 = Data Strobe Used (Motorola Mode) 10 = Reserved. Do not use. 11 = Reserved. Do not use.</p>
QOVF	H18	O	<p>Queue Overflow for Ethernet Mapper: This pin goes high when the transmit or receive queue has overflowed. This pin will go low when the high watermark is reached again.</p>
RLOS/LTC	N1	O	<p>T1/E1/J1 Receive Loss-of-Sync/Loss-of-Transmit Clock: A dual function output that is controlled by the CCR1.0 control bit. This pin can be programmed to either toggle high when the synchronizer is searching for the frame and multiframe or to toggle high if the TCLKT pin has not been toggled for 5μs.</p>
RCL	B5	O	<p>T1/E1/J1 Receive Carrier Loss: Set high when the T1/E1/J1 line interface detects a carrier loss.</p>
RSIGF	P3	O	<p>T1/E1/J1 Receive Signaling-Freeze Output: Set high when the signaling data is frozen by either automatic or manual intervention. Used to alert downstream equipment of the condition.</p>

NAME	PIN	TYPE	FUNCTION
SYSTEM CLOCKS			
SYCLKI	V8	I	System Clock In for Ethernet Mapper: 100MHz System Clock input to the DS33R11, used for internal operation. This clock is buffered and provided at SDCLKO for the SDRAM interface. The DS33R11 also provides a divided version output at the REF_CLKO pin. A clock supply with ± 100 ppm frequency accuracy is suggested.
MCLK	H4	I	Master Clock Input for the T1/E1/J1 Transceiver: A (50ppm) clock source. This clock is used internally for both clock/data recovery and for the jitter attenuator for both T1 and E1 modes. The clock rate can be 16.384MHz, 8.192MHz, 4.096MHz, or 2.048MHz. When using the transceiver in T1-only operation a 1.544MHz (50ppm) clock source can be used.
BPCLK	B1	O	Backplane Clock from T1/E1/J1 Transceiver: A user-selectable synthesized clock output that is referenced to the clock that is output at the RCLKO pin.
8XCLK	K4	O	Eight Times Clock from the T1/E1/J1 Transceiver: An 8x clock that is locked to the recovered network clock provided from the clock/data recovery block (if the jitter attenuator is enabled on the receive side) or from the TDCLKI pin (if the jitter attenuator is enabled on the transmit side).
XTALD	J4	O	Quartz Crystal Driver for the T1/E1/J1 Transceiver: A quartz crystal of 2.048MHz (optional 1.544MHz in T1-only operation) can be applied across MCLK and XTALD instead of a clock source at MCLK. Leave open circuited if a clock source is applied at MCLK.

NAME	PIN	TYPE	FUNCTION
JTAG INTERFACE			
JTCLK1	A7	Ipu	JTAG Clock 1 for the Ethernet Mapper: This signal is used to shift data into JTDI1 on the rising edge and out of JTDO1 on the falling edge.
JTDI1	C9	Ipu	JTAG Data In 1 for the Ethernet Mapper: Test instructions and data are clocked into this pin on the rising edge of JTCLK1. This pin has a 10k Ω pullup resistor.
JTDO1	B7	Oz	JTAG Data Out 1 for the Ethernet Mapper: Test instructions and data are clocked out of this pin on the falling edge of JTCLK1. If not used, this pin should be left unconnected.
JTMS1	C8	Ipu	JTAG Mode Select 1 for the Ethernet Mapper: This pin is sampled on the rising edge of JTCLK1 and is used to place the test access port into the various defined IEEE 1149.1 states. This pin has a 10k Ω pullup resistor.
$\overline{JTRST1}$	C7	Ipu	JTAG Reset 1 for the Ethernet Mapper: $\overline{JTRST1}$ is used to asynchronously reset the test access port controller. After power up, a rising edge on $\overline{JTRST1}$ will reset the test port and cause the device I/O to enter the JTAG DEVICE ID mode. Pulling $\overline{JTRST1}$ low restores normal device operation. $\overline{JTRST1}$ is pulled HIGH internally via a 10k Ω resistor operation. If boundary scan is not used, this pin should be held low.
JTCLK2	A6	Ipu	JTAG Clock 2 for the T1/E1/J1 Transceiver: This signal is used to shift data into JTDI1 on the rising edge and out of JTDO1 on the falling edge.
JTDI2	B6	Ipu	JTAG Data In 2 for the T1/E1/J1 Transceiver: Test instructions and data are clocked into this pin on the rising edge of JTCLK2. This pin has a 10k Ω pullup resistor.
JTDO2	C5	Oz	JTAG Data Out 2 for the T1/E1/J1 Transceiver: Test instructions and data are clocked out of this pin on the falling edge of JTCLK2. If not used, this pin should be left unconnected.
JTMS2	B9	Ipu	JTAG Mode Select 2 for the T1/E1/J1 Transceiver: This pin is sampled on the rising edge of JTCLK2 and is used to place the test-access port into the various defined IEEE 1149.1 states. This pin has a 10k Ω pullup resistor.
$\overline{JTRST2}$	B8	Ipu	JTAG Reset 2 for the T1/E1/J1 Transceiver: $\overline{JTRST2}$ is used to asynchronously reset the test access port controller. After power-up, $\overline{JTRST2}$ must be toggled from low to high. This action will set the device into the JTAG DEVICE ID mode. Normal device operation is restored by pulling $\overline{JTRST2}$ low. $\overline{JTRST2}$ is pulled HIGH internally via a 10k Ω resistor operation.

NAME	PIN	TYPE	FUNCTION
POWER SUPPLIES			
RVDD	K3, L1	—	Receive Analog Positive Supply: Connect to 3.3V power supply.
RVSS	J1, J2, K2, L2, M2	—	Receive Analog Signal Ground: Connect to the common supply ground.
TVDD	U1	—	Transmit Analog Positive Supply: Connect to 3.3V power supply.
TVSS	P1, R3, T3, U2	—	Transmit Analog Signal Ground: Connect to the common supply ground.
DVDD	D1–D17, E17	—	Digital Positive Supply: Connect to 3.3V power supply.
DVSS	N4, P4, R4, T4	—	Digital Signal Ground: Connect to the common supply ground.
VDD1.8	B10, B15, C12, F3, J18, J20, P18, P19, R19, R20, V9, Y9, Y13	I	VDD1.8: Connect to 1.8V power supply.
VDD3	D20, F17, G17, G18, H17, J17, K17, L17, M17, N17, P17, R17, R18, T17, T18, U17	I	VDD3.3: Connect to 3.3V power supply.
VSS	A15, C10, D8, D9, D10, D18, D19, E18, H20, J19, K20, N19, N20, P20, U4–U16, U18, V20, W8, W18, Y1, Y7	I	VSS: Connect to the common supply ground.
N.C.	A9, C6, D6	—	No Connection. Do not connect these pins. Leave these pins open.

Figure 7-1. 256-Ball BGA Pinout

	1	2	3	4	5	6	7	8	9	10	11	12	13	14	15	16	17	18	19	20
A	RCHBLK	TCHBLK	RFSYNC	TDATA	TSSYNC	JTCLK2	JTCLK1	RST	N.C.	INT	CS	D6	D3	D0	VSS	A6	A3	A0	REF_CLK	REF_CLKO
B	BPCLK	LIUC	TPOSI	TSIG	RCL	JTDI2	JTDO1	JTRST2	JTMS2	VDD1.8	RD/DS	D7	D4	D1	VDD1.8	A7	A4	A1	MODEC [0]	MODEC [1]
C	TSYNC	TDCLKO	TNEGI	TSTRST	JTDO2	N.C.	JTRST1	JTMS1	JTDI1	VSS	WR/RW	VDD1.8	D5	D2	A9	A8	A5	A2	MDC	MDIO
D	TDCLKI	TCLKT	TNEGO	TESO	TDEN/TBSYNC	N.C.	CST	VSS	VSS	VSS	DVDD	DVDD	DVDD	DVDD	DVDD	DVDD	DVDD	VSS	VSS	VDD3
E	TPOSO	TSERO	TSERI	TSYSCLK												DVDD	VSS	TXD [3]	TXD [2]	
F	TCLKE	RCLKI	VDD1.8	RSYSCLK													VDD3	TXD [1]	TXD [0]	TX_EN
G	TCHCLK	RCHCLK	RCLKO	RSYNC													VDD3	VDD3	RMIIMIS	DCE DTES
H	RSERI	RSERO	RDATA	MCLK													VDD3	QOVF	TX_CLK	VSS
J	RVSS	RVSS	RPOSI	XTALD													VDD3	VDD1.8	VSS	VDD1.8
K	RTIP	RVSS	RVDD	8XCLK													VDD3	RX_ERR	RX_DV	VSS
L	RVDD	RVSS	RSIG	RNEGI													VDD3	RXD [0]	RXD [1]	RXD [2]
M	RRING	RVSS	RDCLKO	RDCLKI													VDD3	RXD [3]	RX_CRS / CRS_DV	RX_CLK
N	RLOS/LTC	RNEGO	RPOSO	DVSS													VDD3	COL_DE1	VSS	VSS
P	TVSS	RDEN/RBSYNC	RSIGF	DVSS													VDD3	VDD1.8	VDD1.8	VSS
R	TTIP	TTIP	TVSS	DVSS													VDD3	VDD3	VDD1.8	VDD1.8
T	TRING	TRING	TVSS	DVSS													VDD3	VDD3	SDATA [25]	SDATA [26]
U	TVDD	TVSS	RMSYNC	VSS	VSS	VSS	VSS	VSS	VSS	VSS	VSS	VSS	VSS	VSS	VSS	VSS	VDD3	VSS	SDATA [22]	SDATA [24]
V	SDATA [13]	SDATA [11]	SDATA [12]	SDATA [10]	SDATA [6]	SDATA [8]	SDMASK [1]	SYCLKI	VDD1.8	SDCS	SBA [1]	SDA [8]	SDA [5]	SDA [10]	SDMASK [3]	SDMASK [2]	SDATA [29]	SDATA [18]	SDATA [20]	VSS
W	SDATA [15]	SDATA [0]	SDATA [14]	SDATA [9]	SDATA [5]	SDATA [7]	SCAS	VSS	SRAS	SWE	SDA [11]	SDA [1]	SDA [6]	SDA [0]	SDA [3]	SDATA [31]	SDATA [30]	VSS	SDATA [28]	SDATA [23]
Y	VSS	SDATA [2]	SDATA [4]	SDATA [1]	SDATA [3]	SDMASK [0]	VSS	SDCLKO	VDD1.8	SDA [9]	SBA [0]	SDA [7]	VDD1.8	SDA [4]	SDA [2]	SDATA [16]	SDATA [17]	SDATA [27]	SDATA [19]	SDATA [21]

8 FUNCTIONAL DESCRIPTION

The DS33R11 provides interconnection and mapping functionality between Ethernet packet LANs and T1/E1/J1 WAN Time-Division Multiplexed (TDM) systems. The device is composed of a 10/100 Ethernet MAC, packet arbiter, committed information rate controller (CIR), HDLC/X.86 (LAPS) mapper, SDRAM interface, control ports, bit error-rate tester (BERT), and integrated T1/E1/J1 transceiver. The packet interface consists of a MII/RMII Ethernet PHY interface. The Ethernet interface can be configured for 10Mbit/s or 100Mbit/s service. The DS33R11 encapsulates Ethernet traffic with HDLC or X.86 (LAPS) encoding to be transmitted over a T1, E1, or J1 line. The T1/E1/J1 interface also receives encapsulated Ethernet packets and transmits the extracted packets over the Ethernet ports. Access is provided to the signals between the serial port and the integrated T1/E1/J1 transceiver.

The Ethernet packet interface supports MII and RMII interfaces, allowing the DS33R11 to connect to commercially available Ethernet PHY and MAC devices. The Ethernet interface can be configured for 10Mbit/s or 100Mbit/s service, in DTE and DCE configurations. The DS33R11 MAC interface rejects frames with bad FCS and short frames (less than 64 bytes).

Ethernet frames are queued and stored in external 32-bit SDRAM. The DS33R11 SDRAM controller enables connection to a 128Mb SDRAM without external glue logic, at clock frequencies up to 100MHz. The SDRAM is used for both the transmit and receive data queues. The receive queue stores data to be sent from the packet interface to the WAN serial interface. The transmit queue stores data to be sent from the WAN serial interface to the Ethernet LAN packet interface. The external SDRAM can accommodate up to 8192 frames with a maximum frame size of 2016 bytes. The sizing of the queues can be adjusted by software. The user can also program high and low watermarks for each queue that can be used for automatic or manual flow control. The packet data stored in the SDRAM is encapsulated in HDLC or X.86 (LAPS) to be transmitted over the WAN interface. The device also provides the capability for bit and packet scrambling.

The WAN interface also receives encapsulated Ethernet packets and transmits the extracted packets over the Ethernet port. The WAN serial port can operate with a gapped clock, and is designed to be connected to the integrated T1/E1/J1 transceiver for transmission.

The DS33R11 can be configured through an 8-bit microprocessor interface port. Diagnostic capabilities include loopbacks, PRBS pattern generation/detection, and 16-bit loop-up/loop-down code generation and detection. The DS33R11 provides two on-board clock dividers for the system-clock input and reference-clock input for the 802.3 interfaces, further reducing the need for ancillary devices.

The integrated transceiver is a software-selectable T1, E1, or J1 single-chip transceiver (SCT) for short-haul and long-haul applications. The transceiver is composed of an LIU, framer, HDLC controllers, and a TDM backplane interface, and is controlled by the 8-bit parallel port. The transceiver is software compatible with the DS2155 and DS2156.

The LIU is composed of transmit and receive interfaces and a jitter attenuator. The transmit interface is responsible for generating the necessary waveshapes for driving the network and providing the correct source impedance depending on the type of media used. T1 waveform generation includes DSX-1 line build-outs as well as CSU line build-outs of -7.5dB, -15dB, and -22.5dB. E1 waveform generation includes G.703 waveshapes for both 75Ω coax and 120Ω twisted cables. The receive interface provides network termination and recovers clock and data from the network. The receive sensitivity adjusts automatically to the incoming signal and can be programmed for 0 to 43dB or 0 to 12dB for E1 applications and 0 to 30dB or 0 to 36dB for T1 applications. The jitter attenuator removes phase jitter from the transmitted or received signal. The crystal-less jitter attenuator requires only a 2.048MHz MCLK for both E1 and T1 applications (with the option of using a 1.544MHz MCLK in T1 applications) and can be placed in either transmit or receive data paths. An additional feature of the LIU is a CMI coder/decoder for interfacing to optical networks.

On the transmit side, clock, data, and frame-sync signals are provided to the framer by the backplane interface section. The framer inserts the appropriate synchronization framing patterns, alarm information, calculates and inserts the CRC codes, and provides the B8ZS/HDB3 (zero code suppression) and AMI line coding. The receive-side framer decodes AMI, B8ZS, and HDB3 line coding, synchronizes to the data stream, reports alarm information, counts framing/coding/CRC errors, and provides clock/data and frame-sync signals to the backplane interface section.

Both the transmit and receive path of the integrated T1/E1/J1 transceiver also have two HDLC controllers. The HDLC controllers transmit and receive data through the framer block. The HDLC controllers can be assigned to any time slot, group of time slots, portion of a time slot or to FDL (T1) or Sa bits (E1). Each controller has 128-byte FIFOs, thus reducing the amount of processor overhead required to manage the flow of data. In addition, built-in support for reducing the processor time is required in SS7 applications.

The backplane interface provides a versatile method of sending and receiving data from the host system. Elastic stores provide a method for interfacing to asynchronous systems, converting from a T1/E1 network to a 2.048MHz, 4.096MHz, 8.192MHz, or N x 64kHz system backplane. The elastic stores also manage slip conditions (asynchronous interface).

8.1 Processor Interface

Microprocessor control of the DS33R11 is accomplished through the interface pins of the microprocessor port. The 8-bit parallel data bus can be configured for Intel or Motorola modes of operation with the two MODEC[1:0] pins. When MODEC[1:0] = 00, bus timing is in Intel mode, as shown in [Figure 13-9](#) and [Figure 13-10](#). When MODEC[1:0] = 01, bus timing is in Motorola mode, as shown in [Figure 13-11](#) and [Figure 13-12](#). The address space is mapped through the use of 10 address lines, A0-A9. Multiplexed Mode is not supported on the processor interface. See the timing diagrams in *AC Electrical Characteristics* in Section [13](#) for more details.

The Chip Select (\overline{CS}) pin must be brought to a logic low level to gain read and write access to the microprocessor port. With Intel timing selected, the Read (\overline{RD}) and Write (\overline{WR}) pins are used to indicate read and write operations and latch data through the interface. With Motorola timing selected, the Read-Write (\overline{RW}) pin is used to indicate read and write operations while the Data Strobe (\overline{DS}) pin is used to latch data through the interface.

The interrupt output pin (\overline{INT}) is an open-drain output that will assert a logic-low level upon a number of software maskable interrupt conditions. This pin is normally connected to the microprocessor interrupt input. The register map is shown in [Table 11-1](#).

8.1.1 Read-Write/Data Strobe Modes

The processor interface can operate in either read-write strobe mode or data strobe mode. When MODEC[1:0] = 00 the read-write strobe mode is enabled and a negative pulse on \overline{RD} performs a read cycle, and a negative pulse on \overline{WR} performs a write cycle. When MODEC[1:0] pins = 01 the data strobe mode is enabled and a negative pulse on \overline{DS} when \overline{RW} is high performs a read cycle, and a negative pulse on \overline{DS} when \overline{RW} is low performs a write cycle. The read-write strobe mode is commonly called the “Intel” mode, and the data strobe mode is commonly called the “Motorola” mode.

8.1.2 Clear on Read

The latched status registers will clear on a read access. It is important to note that in a multi-task software environment, the user should handle all status conditions of each register at the same time to avoid inadvertently clearing status conditions. The latched status register bits are carefully designed so that an event occurrence cannot collide with a user read access.

8.1.3 Interrupt and Pin Modes

The interrupt (\overline{INT}) pin is configurable to drive high or float when not active. The INTM bit controls the pin configuration, when it is set the \overline{INT} pin will drive high when not active. After reset, the \overline{INT} pin is in high-impedance mode until an interrupt source is active and enabled to drive the interrupt pin.

9 ETHERNET MAPPER

9.1 Ethernet Mapper Clocks

The DS33R11 clocks sources and functions are as follows:

- Serial Transmit Data (TCLKE) and Serial Receive Data (RCLKI) clock inputs are used to transfer data from the serial interface. These clocks can be continuous or gapped.
- System Clock (SYSCLKI) input. Used for internal operation. This clock input cannot be a gapped clock. A clock supply with ± 100 ppm frequency accuracy is suggested. A buffered version of this clock is provided on the SDCLKO pin for the operation of the SDRAM. A divided and buffered version of this clock is provided on REF_CLKO for the RMII/MII interface.
- Packet Interface Reference clock (REF_CLK) input that can be 25MHz or 50MHz. This clock is used as the timing reference for the RMII/MII interface.
- The Transmit and Receive clocks for the MII Interface (TX_CLK and RX_CLK). In DTE mode, these are input pins and accept clocks provided by an Ethernet PHY. In the DCE mode, these are output pins and will output an internally generated clock to the Ethernet PHY. The output clocks are generated by internal division of REF_CLK. In RMII mode, only the REF_CLK input is used.
- REF_CLKO is an output clock that is generated by dividing the 100MHz System clock (SYSCLKI) by 2 or 4.
- A Management Data Clock (MDC) output is derived from SYSCLKI and is used for information transfer between the internal Ethernet MAC and external PHY. The MDC clock frequency is 1.67MHz.

Clocking of the integrated T1/E1/J1 transceiver is discussed in Section [10.1](#). The following table provides the different clocking options for the Ethernet interface.

Table 9-1. Clocking Options for the Ethernet Interface

RMIIMIIIS PIN	SPEED	DCE/ DTE	REF_CLKO OUTPUT	REF_CLK INPUT	RX_CLK	TX_CLK	MDC OUTPUT
0 (MII)	10 Mbps	DTE	25MHz	25MHz ± 100 ppm	Input from PHY	Input from PHY	1.67MHz
0 (MII)	10 Mbps	DCE	25MHz	25MHz ± 100 ppm	2.5MHz (Output)	2.5MHz (Output)	1.67MHz
0 (MII)	100 Mbps	DCE	25MHz	25MHz ± 100 ppm	25MHz (Output)	25MHz (Output)	1.67MHz
1 (RMII)	10 Mbps	—	50MHz	50MHz ± 100 ppm	Not Applicable	Not Applicable	1.67MHz
1 (RMII)	100 Mbps	—	50MHz	50MHz ± 100 ppm	Not Applicable	Not Applicable	1.67MHz

Figure 9-1. Clocking for the DS33R11

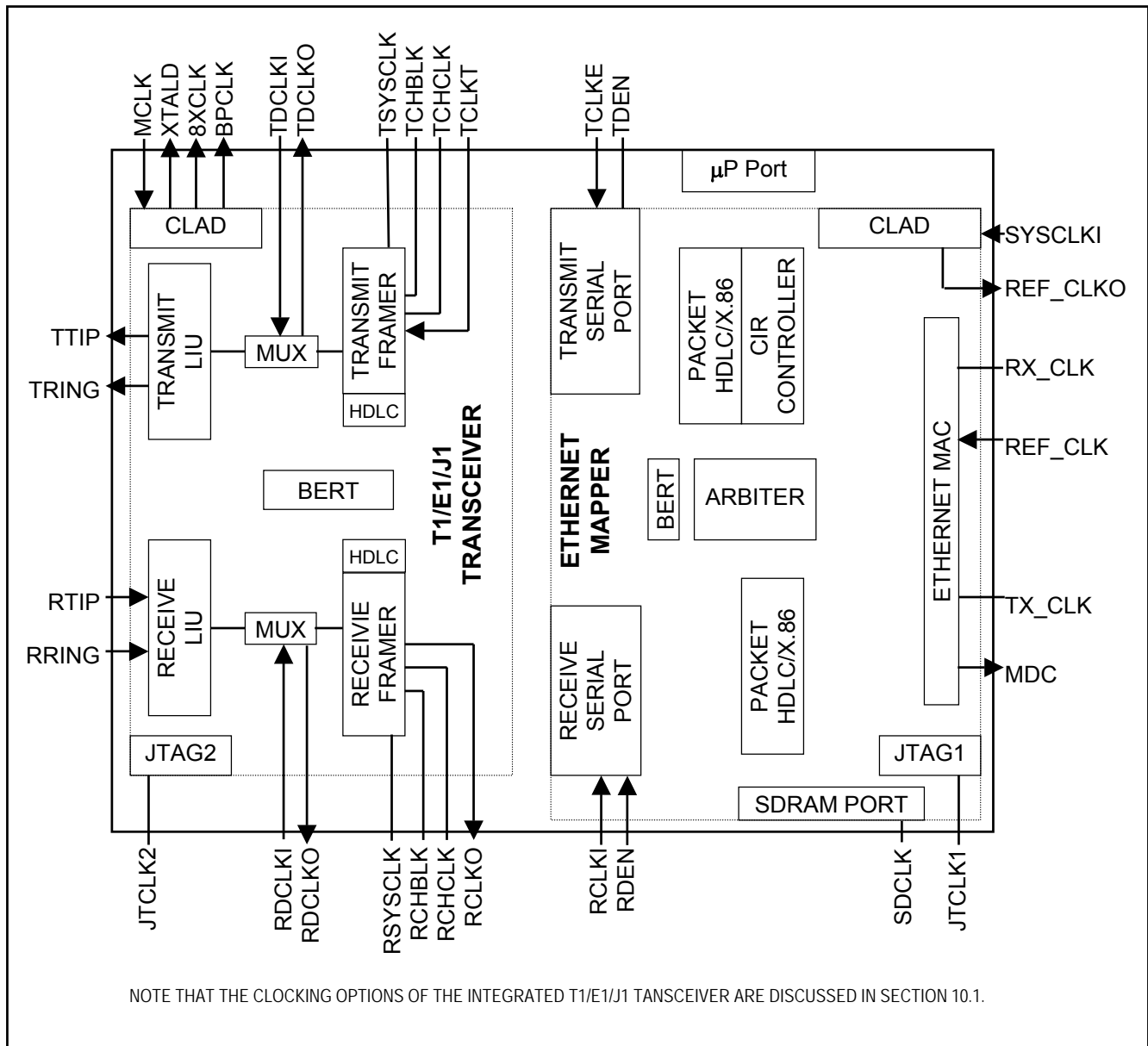

9.1.1 Ethernet Interface Clock Modes

The Ethernet PHY interface has several different clocking requirements, depending on the mode of operation. [Table 9-1](#) outlines the possible clocking modes for the Ethernet Interface. The buffered REF_CLKO output is generated by division of the 100MHz system clock input by the user on SYSCLKI. The frequency of the REF_CLKO pin is automatically determined by the DS33R11 based on the state of the RMIIMIS pin. The REF_CLKO function can be turned off with the [GL.CR1](#).RFOO bit. Note that in DCE and RMII operating modes, the REF_CLKO signal should not be used to provide an input to REF_CLK, due to the reset requirements in these operating modes.

In RMII mode, receive and transmit timing is always synchronous to a 50 MHz clock input on the REF_CLK pin. The source of REF_CLK is expected to be the external PHY. The user has the option of using the 50MHz REF_CLKO output as the timing source for the PHY. More information on RMII mode can be found in [Section 9.15.2](#).

While using MII mode with DTE operation, the MII clocks (RX_CLK and TX_CLK) are inputs that are expected to be provided by the external PHY. While using MII mode with DCE operation, the MII clocks (TX_CLK and RX_CLK) are output by the DS33R11, and are derived from the 25MHz REF_CLK input. More information on MII mode can be found in [Section 9.15.1](#).

9.1.2 Serial Interface Clock Modes

The serial interface timing is determined by the line clocks. Both the transmit and receive clocks (TCLKE and RCLKI) are inputs, and can be gapped.

9.2 Resets and Low Power Modes

The external $\overline{\text{RST}}$ pin and the global reset bit in [GL.CR1](#) create an internal global reset signal. The global reset signal resets the status and control registers on the chip (except the GL.CR1.RST bit) to their default values and resets all the other flops to their reset values. The processor bus output signals are also placed in high-impedance mode when the $\overline{\text{RST}}$ pin is active (low). The global reset bit (GL.CR1.RST) stays set after a one is written to it, but is reset to zero when the external $\overline{\text{RST}}$ pin is active or when a zero is written to it. Allow 5ms after initiating a reset condition for the reset operation to complete.

The Serial Interface reset bit in [LI.RSTPD](#) resets all the status and control registers on the serial interface to their default values, except for the LI.RSTPD.RST bit. The serial interface includes the HDLC encoder/decoder, X86 encoder and decoder and the corresponding serial port. The serial interface reset bit (LI.RSTPD.RST) stays set after a one is written to it, but is reset to zero when the global reset signal is active or when a zero is written to it.

Table 9-2. Reset Functions

RESET FUNCTION	LOCATION	COMMENTS
Hardware Device Reset	$\overline{\text{RST}}$ Pin	Transition from a logic 0 to a logic 1 resets the device.
Hardware JTAG Reset	$\overline{\text{JTRST}}$ Pin	Resets the JTAG test port.
Global Software Reset	GL.CR1	Writing to this bit resets the device.
Serial Interface Reset	LI.RSTPD	Writing to this bit resets the Serial Interface.
Queue Pointer Reset	GL.C1QPR	Writing to this bit resets the Queue Pointers.

There are several features in the DS33R11 to reduce power consumption. The reset bit in the [LI.RSTPD](#) register minimizes power usage in the Serial Interface. Additionally, the $\overline{\text{RST}}$ pin or GL.CR1.RST bit may be held in reset indefinitely to keep the device in a low-power mode. Note that exiting a reset condition requires re-initialization and configuration. For the lowest possible standby current, clocks may be externally gated.

The T1/E1/J1 transceiver contains an on-chip power-up reset function that automatically clears the writeable register space immediately after power is supplied to the transceiver. The user can issue a chip reset at any time. Issuing a reset disrupts traffic flowing through the transceiver until the device is reprogrammed. The reset can be issued through hardware using the TSTRST pin or through software using the SFTRST function in the master mode register. The LIRST (TR.LIC2.6) should be toggled from 0 to 1 to reset the line interface circuitry. (It takes the transceiver about 40ms to recover from the LIRST bit being toggled.) Finally, after the TSYCLK and RSYCLK inputs are stable, the receive and transmit elastic stores should be reset (this step can be skipped if the elastic stores are disabled).

9.3 Initialization and Configuration

EXAMPLE DEVICE INITIALIZATION SEQUENCE:

STEP 1: Apply 3.3V supplies, then apply 1.8V supplies.

STEP 2: Reset the integrated Ethernet Mapper by pulling the $\overline{\text{RST}}$ pin low or by using the software reset bits outlined in Section [9.2](#). Clear all reset bits. Allow 5ms for the reset recovery.

STEP 3: Reset the integrated T1/E1/J1 Transceiver through hardware using the TSTRST pin or through software using the SFTRST function in the master mode register.

STEP 4: The LIRST (TR.LIC2.6) should be toggled from 0 to 1 to reset the line interface circuitry. Allow 40ms for the reset recovery.

STEP 5: Check the Ethernet Mapper Device ID in the [GL.IDRL](#) and [GL.IDRH](#) registers.

STEP 6: Check the T1/E1/J1 Transceiver Device ID in the TR.IDR register.

STEP 7: Configure the system clocks. Allow the clock system to properly adjust.

STEP 8: Initialize the entire remainder of the register space with 00h (or otherwise if specifically noted in the register's definition), including the reserved bits and reserved register locations.

STEP 9: Write FFFFFFFFh to the MAC indirect addresses 010Ch through 010Fh.

STEP 10: Setup connection in the GL.CON1 register.

STEP 11: Configure the Serial Port register space as needed.

STEP 12: Configure the Ethernet Port register space as needed.

STEP 13: Configure the Ethernet MAC indirect registers as needed.

STEP 14: Configure the T1/E1/J1 Framer as needed.

STEP 15: Configure the T1/E1/J1 LIU as needed.

STEP 16: Configure the external Ethernet PHY through the MDIO interface.

STEP 17: Clear all counters and latched status bits.

STEP 18: Set the queue size in the Arbiter and reset the queue pointers for the Ethernet and serial interfaces.

STEP 19: After the TSYCLK and RSYCLK inputs to the T1/E1/J1 transceiver are stable, the receive and transmit elastic stores should be reset (this step can be skipped if the elastic stores are disabled).

STEP 20: Enable Interrupts as needed.

STEP 21: Begin handling interrupts and latched status events.

9.4 Global Resources

In order to maintain software compatibility with the multiport devices in the product family, a set of global registers are located at 0F0h-0FFh. The global registers include Global resets, global interrupt status, interrupt masking, clock configuration, and the Device ID registers. See the *Global Register Definitions* in [Table 11-2](#).

9.5 Per-Port Resources

Multiport devices in this product family share a common set of global registers, BERT, and arbiter. All other resources are per-port.

9.6 Device Interrupts

[Figure 9-2](#) diagrams the flow of interrupt conditions from their source status bits through the multiple levels of information registers and mask bits to the interrupt pin. When an interrupt occurs, the host can read the Global Latched Status registers [GL.LIS](#), [GL.SIS](#), [GL.BIS](#), and [GL.TRQIS](#) to initially determine the source of the interrupt. The host can then read the [LI.TQCTL](#), [LI.TPPSRL](#), [LI.RPPSRL](#), [LI.RX86S](#), [SU.QCRLS](#), or BSRL registers to further identify the source of the interrupt(s). In order to maintain software compatibility with the multiport devices in the product family, the global interrupt status and interrupt enable registers have been preserved, but do not need to be used. If [GL.TRQIS](#) is determined to be the interrupt source, the host will then read the [LI.TPPSRL](#) and [LI.RPPSRL](#) registers for the cause of the interrupt. If [GL.LIS](#) is determined to be the interrupt source, the host will then read the [LI.TQCTL](#), [LI.TPPSRL](#), [LI.RPPSRL](#), and [LI.RX86S](#) registers for the source of the interrupt. If [GL.SIS](#) is the source, the host will then read the [SU.QCRLS](#) register for the source of the interrupt. If [GL.BIS](#) is the source, the host will then read the BSRL register for the source of the interrupt. All Global Interrupt Status Register bits are real-time bits that will clear once the appropriate interrupt has been serviced and cleared, as long as no additional, enabled interrupt conditions are present in the associated status register. All Latched Status bits must be cleared by the host writing a “1” to the bit location of the interrupt condition that has been serviced. In order for individual status conditions to transmit their status to the next level of interrupt logic, they must be enabled by placing a “1” in the associated bit location of the correct Interrupt Enable Register. The Interrupt enable registers are [LI.TPPSRIE](#), [LI.RPPSRIE](#), [LI.RX86LSIE](#), BSRIE, SU.QRIE, GL.LIE, GL.SIE, GL.BIE, and GL.TRQIE. Latched Status bits that have been enabled via Interrupt Enable registers are allowed to pass their interrupt conditions to the Global Interrupt Status Registers. The Interrupt enable registers allow individual Latched Status conditions to generate an interrupt, but when set to zero, they do not prevent the Latched Status bits from being set. Therefore, when servicing interrupts, the user should AND the Latched Status with the associated Interrupt Enable Register in order to exclude bits for which the user wished to prevent interrupt service. This architecture allows the application host to periodically poll the latched status bits for noninterrupt conditions, while using only one set of registers. Note the bit-orders of [SU.QRIE](#) and [SU.QCRLS](#) are different.

Note that the inactive state of the interrupt output pin is configurable. The INTM bit in [GL.CR1](#) controls the inactive state of the interrupt pin, allowing selection of a pull-up resistor or active driver.

The interrupt structure is designed to efficiently guide the user to the source of an enabled interrupt source. The latched status bits for the interrupting entity must be read to clear the interrupt. Also reading the latched status bit will reset all bits in that register. During a reset condition, interrupts cannot be generated. The interrupts from any source can be blocked at a global level by the placing a zero in the global interrupt enable registers ([GL.LIE](#), [GL.SIE](#), [GL.BIE](#), and [GL.TRQIE](#)). Reading the Latched Status bit for all interrupt generating events will clear the interrupt status bit and Interrupt signal will be de-asserted.

Note that the integrated T1/E1/J1 transceiver also generates interrupts, as discussed in Section [10.3](#).

Figure 9-2. Device Interrupt Information Flow Diagram

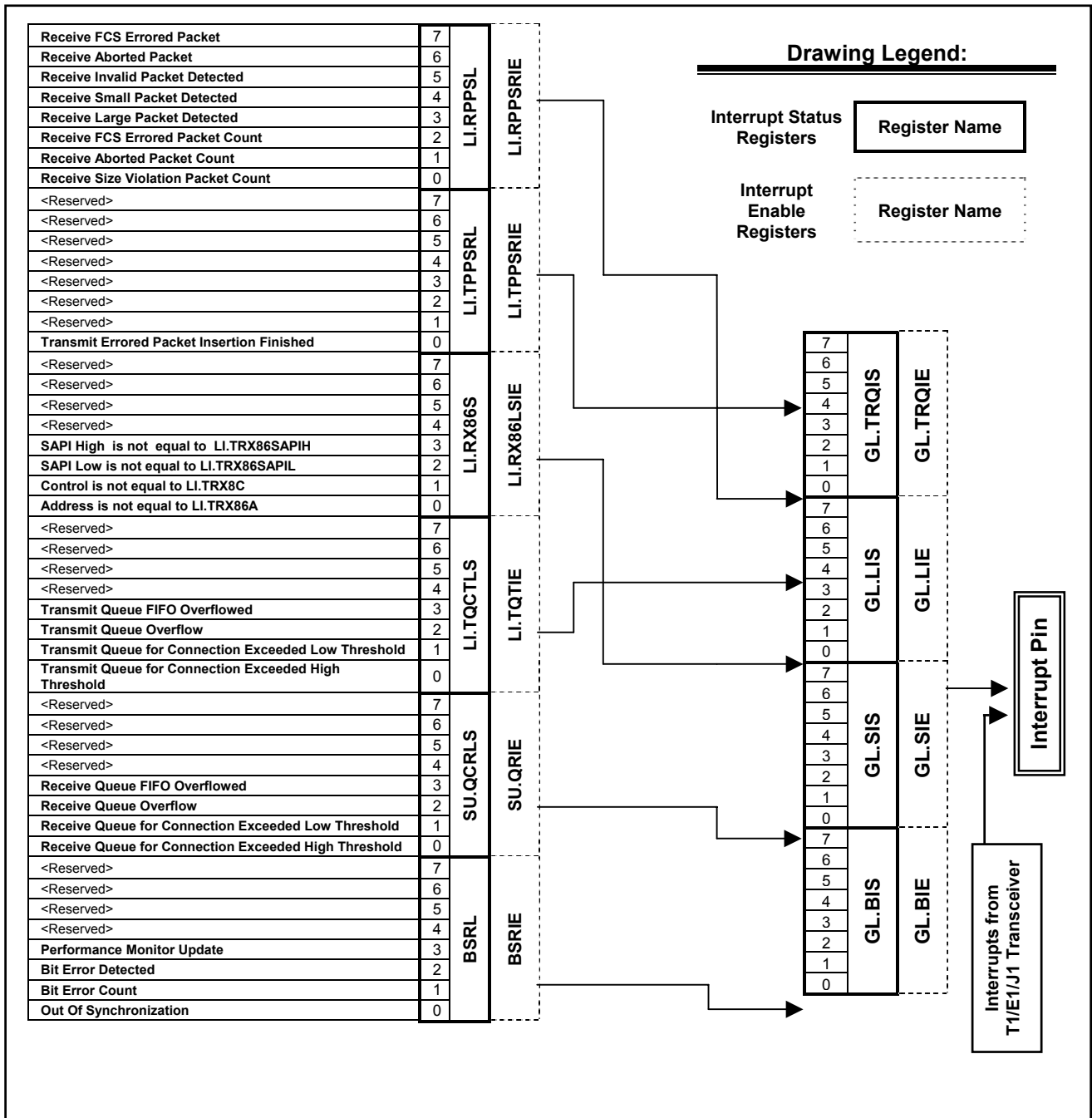

9.7 Interrupt Information Registers

The interrupt information registers provide an indication of which status registers (SR1 through SR9) are generating an interrupt. When an interrupt occurs, the host can read TR.IIR1 and TR.IIR2 to quickly identify which of the nine status registers are causing the interrupt.

9.8 Status Registers

When a particular event or condition has occurred (or is still occurring in the case of conditions), the appropriate bit in a status register is set to a 1. All of the status registers operate in a latched fashion. This means that if an event or condition occurs a bit is set to a 1. It remains set until the user reads that bit. An event bit is cleared when it is read and it is not set again until the event has occurred again. Condition bits such as RBL, RLOS, etc., remain set if the alarm is still present.

The user always proceeds a read of any of the status registers with a write. The byte written to the register informs the device which bits the user wishes to read and have cleared. The user writes a byte to one of these registers, with a 1 in the bit positions the user wishes to read and a 0 in the bit positions the user does not wish to obtain the latest information on. When a 1 is written to a bit location, the read register is updated with the latest information. When a 0 is written to a bit position, the read register is not updated and the previous value is held. A write to the status registers is immediately followed by a read of the same register. This write-read scheme allows an external microcontroller or microprocessor to individually poll certain bits without disturbing the other bits in the register. This operation is key in controlling the device with higher order languages.

Status register bits are divided into two groups, condition bits and event bits. Condition bits are typically network conditions such as loss-of-sync or all-ones detect. Event bits are typically markers such as the one-second timer, elastic store slip, etc. Each status register bit is labeled as a condition or event bit. Some of the status registers have bits for both the detection of a condition and the clearance of the condition. For example, TR.SR2 has a bit that is set when the device goes into a loss-of-sync state (TR.SR2.0, a condition bit) and a bit that is set (TR.SR2.4, an event bit) when the loss-of-sync condition clears (goes in sync). Some of the status register bits (condition bits) do not have a separate bit for the "condition clear" event but rather the status bit can produce interrupts on both edges, setting and clearing. These bits are marked as double interrupt bits. An interrupt is produced when the condition occurs and when it clears.

9.9 Information Registers

Information registers operate the same as status registers except they cannot cause interrupts. They are all latched except for TR.INFO7 and some of the bits in TR.INFO5 and TR.INFO6. TR.INFO7 register is a read-only register. It reports the status of the E1 synchronizer in real time. TR.INFO7 and some of the bits in TR.INFO6 and TR.INFO5 are not latched and it is not necessary to precede a read of these bits with a write.

9.10 Serial Interface

The Serial (WAN) interface is intended to be connected to the integrated T1/E1/J1 Transceiver. However, the interface supports time-division multiplexed, serial data input and output up to 52 Mbit/s. The Serial interface receives and transmits encapsulated Ethernet packets. The Serial Interface block consists of the physical serial port and HDLC / X.86 engine. The physical interface consists of a Transmit Data, Transmit Clock, Transmit Enable, Receive Data, Receive Clock, and Receive Enable. The WAN serial port can operate with a gapped clock, and can be connected to a framer, electrical LIU, optical transceiver, or T/E-Carrier transceiver for transmission to the WAN.

9.11 Connections and Queues

The multi-port devices in this product family provide bidirectional cross-connections between the multiple Ethernet ports and Serial ports when operating in software mode. A single connection is preserved in this single-port device to provide software compatibility with multi-port devices. The connection will have an associated transmit and receive queue. Note that the terms “Transmit Queue” and “Receive Queue” are with respect to the Ethernet Interface. The Receive queue is for data arriving from Ethernet interface to be transmitted to the WAN interface. The Transmit queue is for data arriving from the WAN to be transmitted to the Ethernet interface. Hence the transmit and receive direction terminology is the same as is used for the Ethernet MAC port.

The user can define the connection and the size of the transmit and receive queues. The size is adjustable in units of 32 (by 2048 byte) packets. The external SDRAM can hold up to 8192 packets of data. The user must ensure that all the connection queues do not exceed this limit. The user also must ensure that the transmit and receive queues do not overlap each other. Unidirectional connections are not supported.

When the user changes the queue sizes, the connection must be torn down and re-established. When a connection is disconnected all transmit and receive queues associated with the connection are flushed and a “1” is sourced towards the Serial transmit and the HDLC receiver. The clocks to the HDLC are sourced a “0”.

The user can also program high and low watermarks. If the queue size grows past the High watermark, an interrupt is generated if enabled. The registers of relevance are described in [Table 9-3](#). The [AR.TQSC1](#) size provides the size of the transmit queue for the connection. The high watermark will set a latched status bit. The latched status bit will clear when the register is read. The status bit is indicated by [LI.TQCTL5.TQHT5](#). Interrupts can be enabled on the latched bit events by [LI.TQTIE](#). A latched status bit ([LI.TQCTL5.TQLTS](#)) is also set when the queue crosses a low watermark.

The Receive Queue functions in a similar manner. Note that the user must ensure that sizes and watermarks are set in accordance with the configuration speed of the Ethernet and Serial interfaces. The DS33R11 does not provide error indication if the user creates a connection and queue that overwrites data for another connection queue. The user must take care in setting the queue sizes and watermarks. The registers of relevance are [AR.RQSC1](#) and [SU.QCRLS](#). Queue size should never be set to 0.

It is recommended that the user reset the queue pointers for the connection after disconnection. The pointers must be reset before a connection is made. If this disconnect/connect procedure is not followed, incorrect data may be transmitted. The proper procedure for setting up a connection follows:

- Set up the queue sizes for both transmit and receive queue ([AR.TQSC1](#) and [AR.RQSC1](#)).
- Set up the high/low thresholds and interrupt enables if desired ([GL.TRQIE](#), [LI.TQTIE](#), [SU.QRIE](#)).
- Reset all the pointers for the connection desired ([GL.C1QPR](#)).
- Set up the connections ([GL.CON1](#)).
- If a connection is disconnected, reset the queue pointers after the disconnection.

Table 9-3. Registers Related to Connections and Queues

REGISTER	FUNCTION
GL.CON1	Enables connection between the Ethernet Interface and the Serial Interface. Note that once connection is set up, then the queues and thresholds can be setup for that connection.
AR.TQSC1	Size for the Transmit Queue in Number of 32—2K packets.
AR.RQSC1	Size for the Receive Queue in Number of 32—2K packets.
GL.TRQIE	Interrupt enable for items related to the connections at the global level
GL.TRQIS	Interrupt enable status for items related to the connections at the global level
LI.TQTIE	Enables for the Transmit queue crossing high and low thresholds
LI.TQCTLS	Latched status bits for connection high and low thresholds for the transmit queue.
SU.QRIE	Enables for the receive queue crossing high and low thresholds
SU.QCRLS	Latched status bits for receive queue high and low thresholds.
GL.C1QPR	Resets the connection pointer.

9.12 Arbiter

The Arbiter manages the transport between the Ethernet port and the Serial port. It is responsible for queuing and dequeuing packets to a single external SDRAM. The arbiter handles requests from the HDLC and MAC to transfer data to and from the SDRAM.

9.13 Flow Control

Flow control may be required to ensure that data queues do not overflow and packets are not lost. The DS33R11 allows for optional flow control based on the queue high watermark or through host processor intervention. There are 2 basic mechanisms that are used for flow control:

- In half duplex mode, a jam sequence is sent that causes collisions at the far end. The collisions cause the transmitting node to reduce the rate of transmission.
- In full duplex mode, flow control is initiated by the receiving node sending a pause frame. The pause frame has a timer parameter that determines the pause timeout to be used by the transmitting node.

Note that the terms “transmit queue” and “receive queue” are with respect to the Ethernet Interface. The Receive Queue is the queue for the data that arrives on the MII/RMII interface, is processed by the MAC and stored in the SDRAM. Transmit queue is for data that arrives from the Serial port, is processed by the HDLC and stored in the SDRAM to be sent to the MAC transmitter.

The following flow control options are possible:

- Automatic flow control can be enabled in software mode with the [SU.GCR.ATFLOW](#) bit. Note that the user does not have control over [SU.MACFCR.FCE](#) and [FCB](#) bits if [ATFLOW](#) is set. The mechanism of sending pause or jam is dependent only on the receive queue high threshold.
- Manual flow control can be performed through software when [SU.GCR.ATFLOW](#)=0. The host processor must monitor the receive queues and generate pause frames (full duplex) and/or jam bytes through the [SU.MACFCR.FCB](#), [SU.GCR.JAME](#), and [SU.MACFCR.FCE](#) bits.

Note that in order to use flow control, the receive queue size (in [AR.RQSC1](#)) must be 02h or greater. The receive queue high threshold (in [SU.RQHT](#)) must be set to 01h or greater, but must be less than the queue size. If the high threshold is set to the same value as the queue size, automatic flow control will not be effective. The high threshold must always be set to less than the corresponding queue size.

The following table provides all the options on flow control mechanism for DS33R11.

Table 9-4. Options for Flow Control

TYPE	MODE			
	Half Duplex; Manual Flow Control	Half Duplex; Automatic Flow Control	Full Duplex; Manual Flow Control	Full Duplex; Automatic Flow Control
Configuration	Half Duplex; Manual Flow Control	Half Duplex; Automatic Flow Control	Full Duplex; Manual Flow Control	Full Duplex; Automatic Flow Control
ATFLOW Bit	0	1	0	1
JAME Bit	Controlled By User	Controlled Automatically	N/A	N/A
FCB Bit (Pause)	N/A	N/A	Controlled by User	Controlled Automatically
FCE Bit	Controlled By User	Controlled Automatically	Controlled By User	Controlled Automatically
Pause Timer	N/A	N/A	Programmed by User	Programmed by User

9.13.1 Full Duplex Flow Control

Automatic flow control is enabled by default. The host processor can disable this functionality with [SU.GCR.ATFLOW](#). The flow control mechanism is governed by the high watermarks ([SU.RQHT](#)). The [SU.RQLT](#) low threshold can be used as indication that the network congestion is clearing up. The value of [SU.RQLT](#) does not affect the flow control. When the connection queue high threshold is exceeded the DS33R11 will send a pause frame with the timer value programmed by the user. See [Table 9-6](#) for more information. It is recommended that 80 slots (80 by 64 bytes or 5120 bytes) be used as the standard timer value.

The pause frame causes the distant transmitter to “pause for a time” before starting transmission again. The pause command has a multicast address 01-80-62-00-00-01. The high and low thresholds for the receive queue are configurable by the user but it is recommended that the high threshold be set approximately 96 packets from the maximum size of the queue and the low threshold 96 packets lower than the high threshold. The DS33R11 will send a pause frame as the queue has crossed the high threshold and a frame is received. Pause is sent every time a frame is received in the “high threshold state”. Pause control will only take care of temporary congestion. Pause control does not take care of systems where the traffic throughput is too high for the queue sizes selected. If the flow control is not effective the receive queue will eventually overflow. This is indicated by [SU.QCRLS.RQOVFL](#) latched bit. If the receive queue is overflowed any new frames will not be received.

The user has the option of not enabling automatic flow control. In this case the thresholds and corresponding interrupt mechanism to send pause frame by writing to flow control busy bit in the MAC flow control registers [SU.MACFCR.FCB](#), [SU.GCR.JAME](#), and [SU.MACFCR](#). This allows the user to set not only the watermarks but also to decide when to send a pause frame or not based on watermark crossings.

On the receive side the user has control over whether to respond to the pause frame sent by the distant end (PCF bit). Note that if automatic flow control is enabled the user cannot modify the FCE bit in the MAC flow control register. On the Transmit queue the user has the option of setting high and low thresholds and corresponding interrupts. **There is no automatic flow control mechanism for data received from the Serial side waiting for transmission over the Ethernet interface during times of heavy Ethernet congestion.**

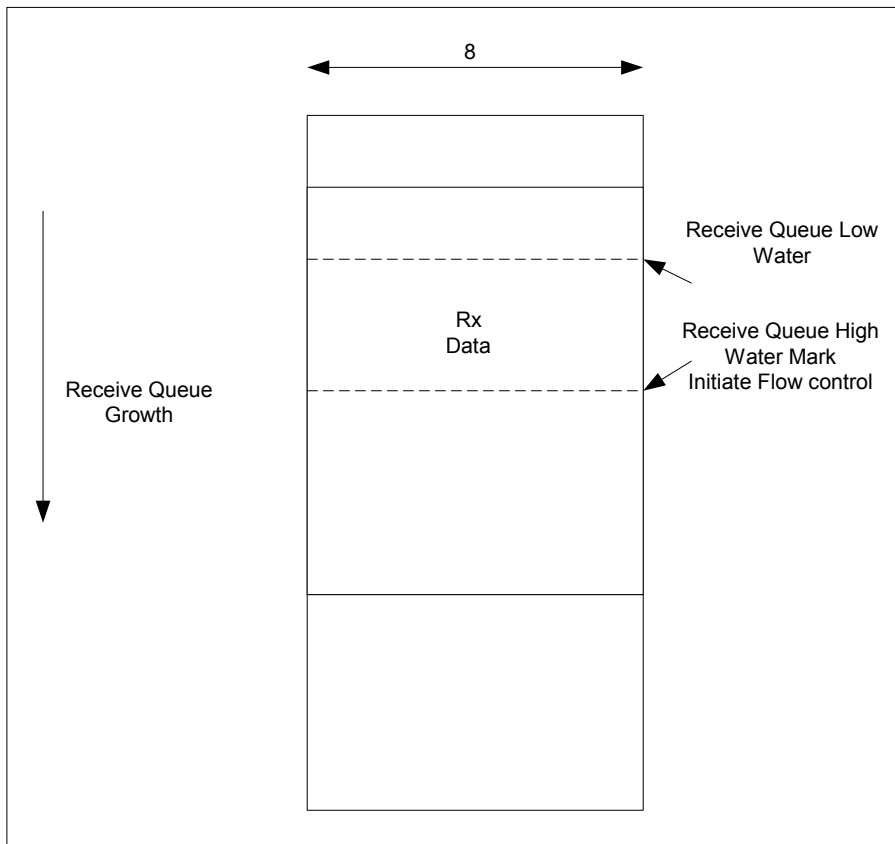
Figure 9-3. Flow Control Using Pause Control Frame

9.13.2 Half Duplex Flow Control

Half duplex flow control uses a jamming sequence to exert backpressure on the transmitting node. The receiving node jams the first 4 bytes of a packet that are received from the MAC in order to cause collisions at the distant end. In both 100Mbit/s and 10Mbit/s MII/RMII modes, 4 bytes are jammed upon reception of a new frame. Note that the jamming mechanism does not jam the current frame that is being received during the watermark crossing, but will wait to jam the next frame after the [SU.RQHT](#) bit is set. If the queue remains above the high threshold, received frames will continue to be jammed. This jam sequence is stopped when the queue falls below the high threshold.

9.13.3 Host-Managed Flow Control

Although automatic flow control is recommended, flow control by the host processor is also possible. By utilizing the high watermark interrupts, the host processor can manually issue pause frames or jam incoming packets to exert backpressure on the transmitting node. Pause frames can be initiated with `SU.MACFCR.FCB` bit. Jam sequences can be initiated by setting `SU.GCR.JAME`. The host can detect pause frames by monitoring `SU.RFSB3.UF` and `SU.RFSB3.CF`. Jammed frames will be indistinguishable from packet collisions.

9.14 Ethernet Interface Port

The Ethernet port interface allows for direct connection to an Ethernet PHY. The interface consists of a 10/100Mbit/s MII/RMII interface and an Ethernet MAC. In RMII operation, the interface contains seven signals with a reference clock of 50 MHz. In MII operation, the interface contains 17 signals and a clock reference of 25MHz. The DS33R11 can be configured to RMII or MII interface by the Hardware pin RMIIMIIS. If the port is configured for MII in DCE mode, REF_CLK must be 25MHz. The DS33R11 will internally generate the TX_CLK and RX_CLK outputs (at 25MHz for 100Mbps, 2.5MHz for 10Mbps) required for DCE mode from the REF_CLK input. In MII mode with DTE operation, the TX_CLK and RX_CLK signals are generated by the PHY and are inputs to the DS33R11. For more information on clocking the Ethernet Interface, see Section 9.1.

The data received from the MII or RMII interface is processed by the internal IEEE 802.3 compliant Ethernet MAC. The user can select the maximum frame size (up to 2016 bytes) that is received with the [SU.RMFSRH](#) and [SU.RMFSRL](#) registers. The maximum frame length (in bits) is the number specified in SU.RMFSRH and SU.RMFSRL multiplied by 8. **Any programmed value greater than 2016 bytes will result in unpredictable behavior and should be avoided.** The maximum frame size is shown in [Figure 9-4](#). The length includes only destination address, source address, VLAN tag (2 bytes), type length field, data and CRC32. The frame size is different than the 802.3 “type length field.”

Frames from the Ethernet PHY or received from the packet processor are rejected if greater than the maximum frame size specified. Each Ethernet frame sent or received generates status bits ([SU.TFSH](#) and [SU.TFSL](#) and [SU.RFSB0](#) to [SU.RFSB3](#)). These are real-time status registers and will change as each frame is sent or received. Hence they are useful to the user only when one frame is sent or received and the status is associated with the frame sent or received.

Figure 9-4. IEEE 802.3 Ethernet Frame

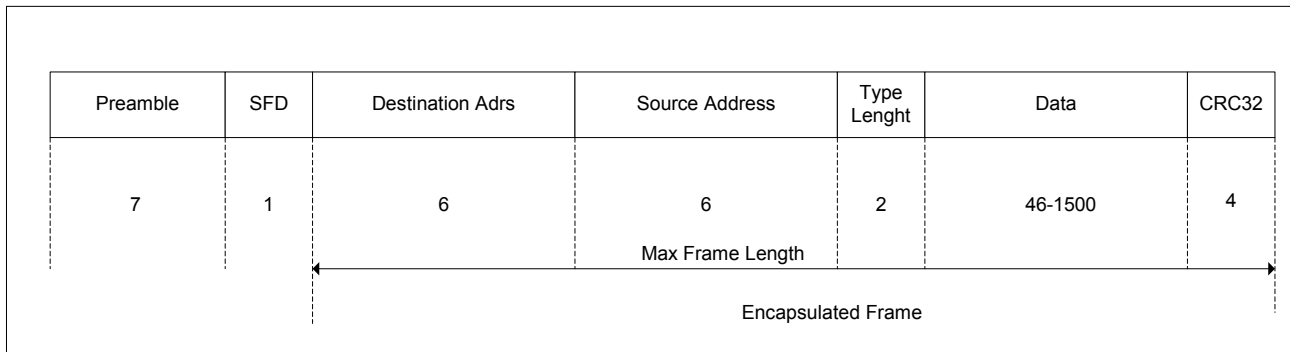

The distant end will normally reject the sent frames if jabber timeout, Loss of carrier, excessive deferral, late collisions, excessive collisions, under run, deferred or collision errors occur. Transmission of a frame under any of these errors will generate a status bit in SU.TFSL, SU.TFSH. The DS33R11 provides user the option to automatically retransmit the frame if any of the errors have occurred through the bit settings in [SU.TFRC](#). Deferred frames and heartbeat fail have separate resend control bits (SU.TFRC.TFBFCB and SU.TFRC.TPRHBC). If there is no carrier (indicated by the MAC Transmit Packet Status), the transmit queue (data from the Serial Interface to the SDRAM to Ethernet Interface) can be selectively flushed. This is controlled by SU.TFRC.NCFQ.

The MAC circuitry generates a frame status for every frame that is received. This real time status can be read by [SU.RFSB0](#) to [SU.RFSB3](#). Note the frame status is the “real time” status and hence the value will change as new frames are received. Hence the real time status reflects the status in time and may not correspond to the current received frame being processed. This is also true for the transmitted frames.

Frames with errors are usually rejected by the DS33R11. The user has the option of accepting frames by settings in Receive Frame Rejection Control register ([SU.RFRC](#)). The user can program whether to reject or accept frames with the following errors:

- MII error asserted during the reception of the frame
- Dribbling bits occurred in the frame
- CRC error occurred
- Length error occurred—the length indicated by the frame length is inconsistent with the number of bytes received
- Control frame was received. The mode must be full duplex
- Unsupported control frame was received

Note that frames received that are runt frames or frames with collision will automatically be rejected.

Table 9-5. Registers Related to Setting the Ethernet Port

REGISTER	NAME	FUNCTION
Transmit Frame Resend Control	SU.TFRC	This register determines if the current frame is retransmitted due to various transmit errors.
Transmit Frame Status Low and Transmit Frame Status High	SU.TFSL and SU.TFSH	These two registers provide the real-time status of the transmit frame. Only apply to the last frame transmitted.
Receive Frame Status Byte 0 to 3	SU.RFSB0 to 3	These registers provide the real-time status for the received frame. Only apply to the last frame received.
Receive Frame Rejection Control	SU.RFRC	This register provides settings for reception or rejection of frame based on errors detected by the MAC.
Receiver Maximum Frame High and Receiver Maximum Frame Low	SU.RMFSRH and SU.RMFSRL	The settings for this register provide the maximum size of frames to be accepted from the MII/RMII receive interface.
MAC Control	SU.MACCR	This register provides configuration control for the MAC.

9.14.1 DTE and DCE Mode

The Ethernet MII/RMII port can be configured for DCE or DTE Mode. When the port is configured for the DTE Mode it can be connected to an Ethernet PHY. In DCE mode, the port can be connected to MII/RMII MAC devices other than an Ethernet PHY. The DTE/DCE connections for the DS33R11 in MII mode are shown in the following two figures.

In DCE Mode, the DS33R11 transmitter is connected to an external receiver and DS33R11 receiver is connected to an external MAC transmitter. The selection of DTE or DCE mode is done by the hardware pin DCEDTES.

Figure 9-5. Configured as DTE Connected to an Ethernet PHY in MII Mode

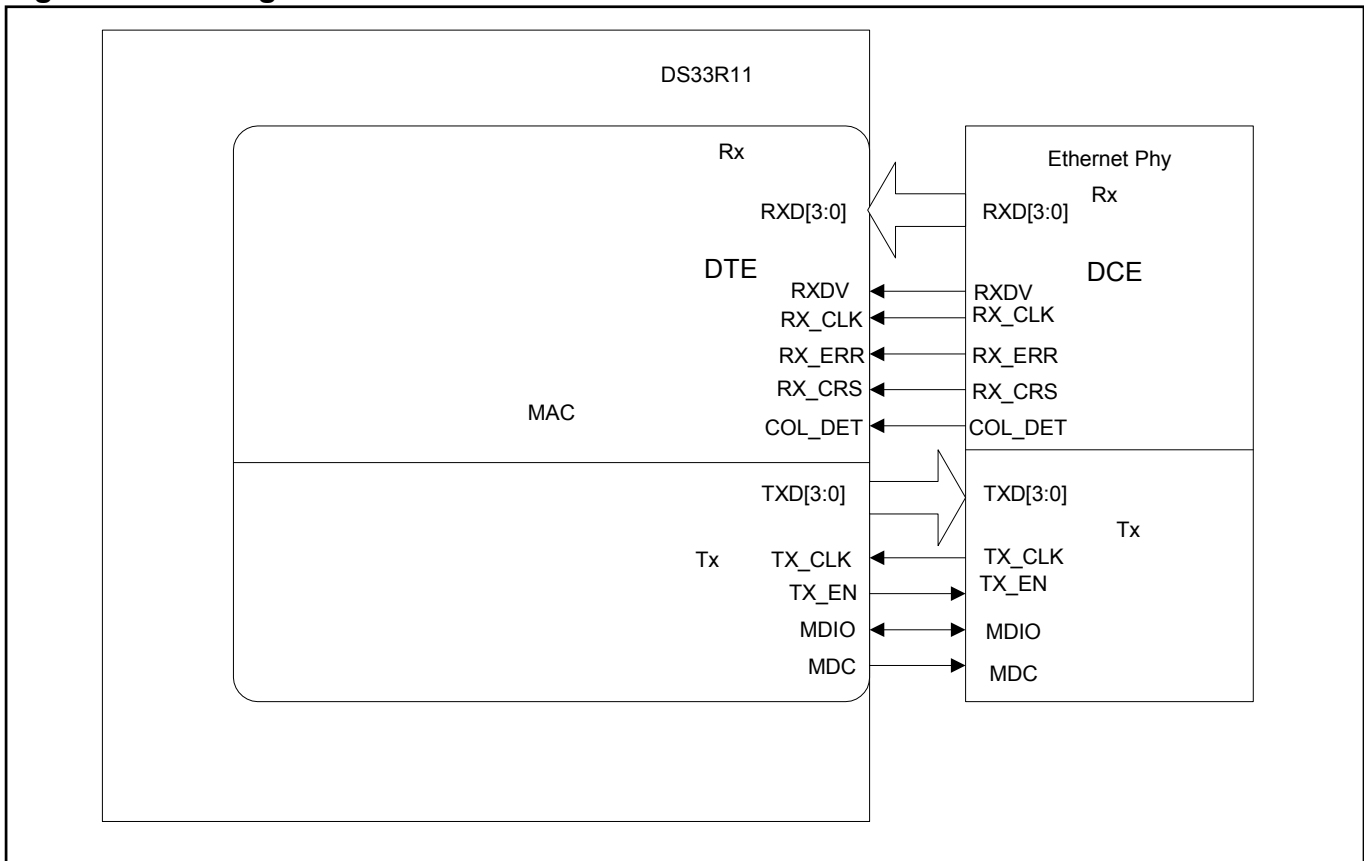
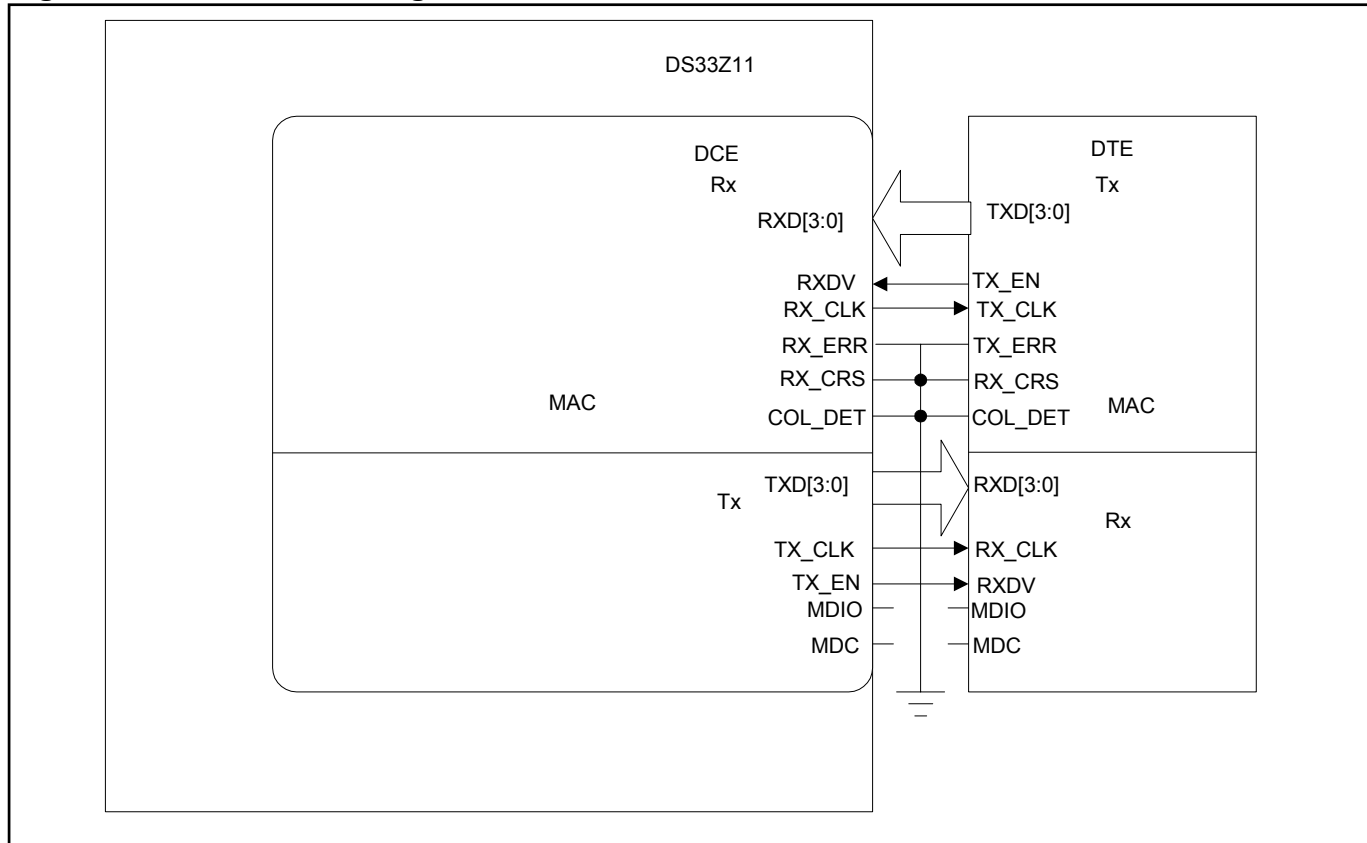

Figure 9-6. DS33R11 Configured as a DCE in MII Mode

9.15 Ethernet MAC

Indirect addressing is required to access the MAC register settings. Writing to the MAC registers requires the [SU.MACWD0-3](#) registers to be written with 4 bytes of data. The address for the write operation must be written to [SU.MACAWL](#) and [SU.MACAWH](#). A write command is issued by writing a zero to [SU.MACRWC.MCRW](#) and a one to [SU.MACRWC.MCS](#) (MAC command status). MCS is cleared by the DS33R11 when the operation is complete.

Reading from the MAC registers requires the [SU.MACRADH](#) and [SU.MACRADL](#) registers to be written with the address for the read operation. A read command is issued by writing a one to [SU.MACRWC.MCRW](#) and a zero to [SU.MACRWC.MCS](#). [SU.MACRWC.MCS](#) is cleared by the DS33R11 when the operation is complete. After MCS is clear, valid data is available in [SU.MACRD0-SU.MACRD3](#). Note that only one operation can be initiated (read or write) at one time. Data cannot be written or read from the MAC registers until the MCS bit has been cleared by the device. The MAC registers are detailed in the following table.

Table 9-6. MAC Control Registers

ADDRESS	REGISTER	DESCRIPTION
0000h-0003h	SU.MACCR	MAC Control Register. This register is used for programming full duplex, half duplex, promiscuous mode, and back-off limit for half duplex. The transmit and receive enable bits must be set for the MAC to operate.
0014h-0017h	SU.MACMIIA	MAC MII Management (MDIO) Address Register. The address for PHY access through the MDIO interface.
0018h-001Bh	SU.MACMIID	MAC MII (MDIO) Data Register. Data to be written to (or read from) the PHY through MDIO interface.
001Ch-001Fh	SU.MACFCR	MAC Flow Control Register
0100h-0103h	SU.MMCCTRL	MAC MMC Control Register. Bit 0 for resetting the status counters.

Table 9-7. MAC Status Registers

ADDRESS	REGISTER	DESCRIPTION
0200h-0203h	SU.RxFrmCtr	All frames received counter.
0204h-0207h	SU.RxFrmOkCtr	Number of received frames that are good.
0300h-0303h	SU.TxFrmCtr	Number of frames transmitted.
0308h-030Bh	SU.TxBytesCtr	Number of bytes transmitted.
030Ch-030Fh	SU.TxBytesOkCtr	Number of bytes transmitted with good frames.
0334h-0337h	SU.TxFrmUndr	Transmit FIFO underflow counter.
0338h-033Bh	SU.TxBdFrmCtr	Transmit number of frames aborted.

9.15.1 MII Mode Options

The Ethernet interface can be configured for MII operation by setting the hardware pin RMIIMIIS low. The MII interface consists of 17 pins. For instructions on clocking the Ethernet Interface while in MII mode, see Section 9.1. Diagrams of system connections for MII operation are shown in [Figure 9-5](#) and [Figure 9-6](#).

9.15.2 RMI Mode

The Ethernet interface can be configured for RMI operation by setting the hardware pin RMIIMIIS high. RMI interface operates synchronously from the external 50MHz reference (REF_CLK). Only seven signals are required. The following figure shows the RMI architecture. Note that DCE mode is not supported for RMI mode and RMI is valid only for full duplex operation.

Figure 9-7. RMI Interface

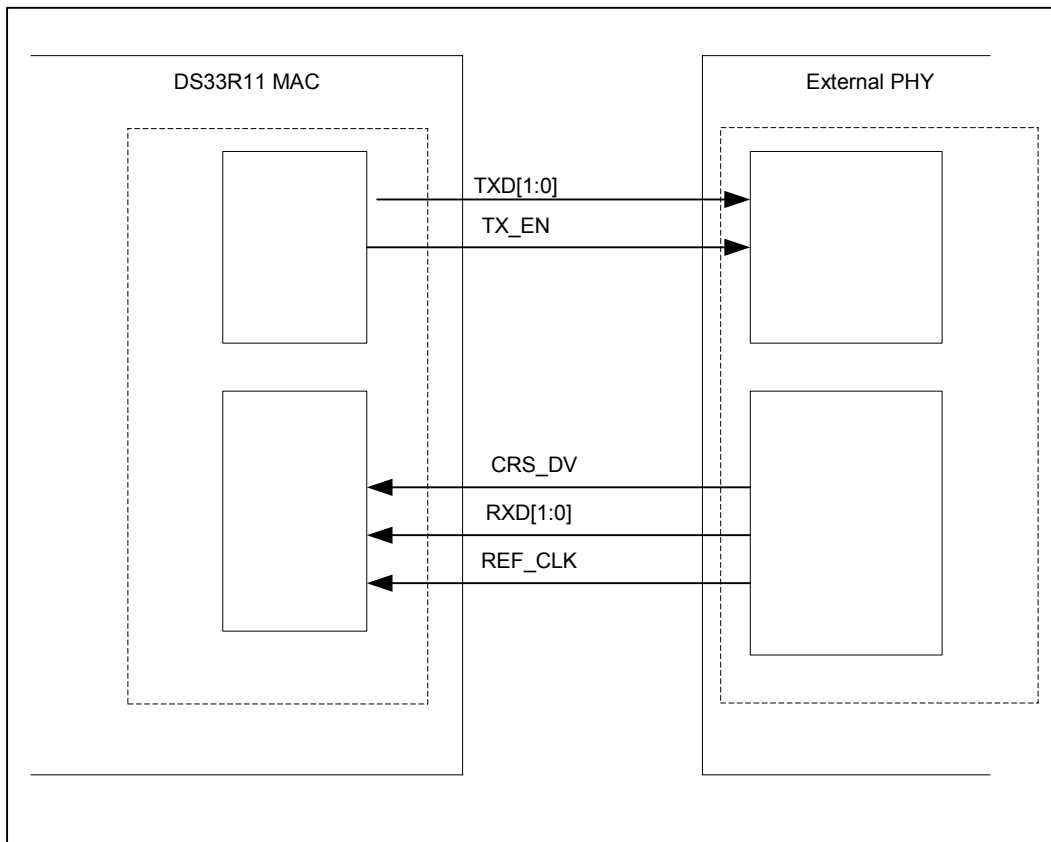

9.15.3 PHY MII Management Block and MDIO Interface

The MII Management Block allows for the host to control up to 32 PHYs, each with 32 registers. The MII block communicates with the external PHY using 2-wire serial interface composed of MDC (serial clock) and MDIO for data. The MDIO data is valid on the rising edge of the MDC clock. The Frame format for the MII Management Interface is shown [Figure 9-8](#). The read/write control of the MII Management is accomplished through the indirect SU.MACMIIA MII Management Address Register and data is passed through the indirect SU.MACMIID Data Register. These indirect registers are accessed through the MAC Control Registers defined in [Table 9-6](#). The MDC clock is internally generated and runs at 1.67MHz.

Figure 9-8. MII Management Frame

	Preamble 32 bits	Start 2 bits	Opco de 2 bits	Phy Adrs 5 bits	Phy Reg 5 bits	Turn Aroun d 2 bits	Data 16 bits	Idle 1 Bit
READ	111...111	01	10	PHYA[4:0]	PHYR[4:0]	ZZ	ZZZZZZZZ	Z
WRITE	111...111	01	01	PHYA[4:0]	PHYR[4:0]	10	PHYD[15:0]	Z

9.16 BERT in the Ethernet Mapper

The BERT in the Ethernet Mapper can be used for generation and detection of BERT patterns. The BERT is a software programmable test pattern generator and monitor capable of meeting most error performance requirements for digital transmission equipment. The following restrictions are related to the BERT:

- The RDEN and TDEN are inputs that can be used to “gap” bits.
- BERT will transmit even when the device is set for X.86 mode and TDEN is configured as an output.
- The normal traffic flow is halted while the BERT is in operation.
- If the BERT is enabled for a Serial port, it will override the normal connection.
- If there is a connection overridden by the BERT, when BERT operation is terminated the normal operation is restored.

The transmit direction generates the programmable test pattern, and inserts the test pattern payload into the data stream. The receive direction extracts the test pattern payload from the receive data stream, and monitors the test pattern payload for the programmable test pattern.

BERT Features

- PRBS and QRSS patterns of 2^9-1 , $2^{15}-1$ $2^{23}-1$ and QRSS pattern support.
- Programmable repetitive pattern. The repetitive pattern length and pattern are programmable. [length n = 1 to 32 and pattern = 0 to $(2^n - 1)$].
- 24-bit error count and 32-bit bit count registers.
- Programmable bit error insertion. Errors can be inserted individually.

9.16.1 Receive Data Interface

9.16.1.1 Receive Pattern Detection

The Receive BERT receives only the payload data and synchronizes the receive pattern generator to the incoming pattern. The receive pattern generator is a 32-bit shift register that shifts data from the least significant bit (LSB) or bit 1 to the most significant bit (MSB) or bit 32. The input to bit 1 is the feedback. For a PRBS pattern (generating polynomial $x^n + x^y + 1$), the feedback is an XOR of bit n and bit y . For a repetitive pattern (length n), the feedback is bit n . The values for n and y are individually programmable (1 to 32). The output of the receive pattern generator is the feedback. If QRSS is enabled, the feedback is an XOR of bits 17 and 20, and the output is forced to one if the next 14 bits are all zeros. QRSS is programmable (on or off). For PRBS and QRSS patterns, the feedback is forced to one if bits 1 through 31 are all zeros. Depending on the type of pattern programmed, pattern detection performs either PRBS synchronization or repetitive pattern synchronization.

9.16.1.2 PRBS Synchronization

PRBS synchronization synchronizes the receive pattern generator to the incoming PRBS or QRSS pattern. The receive pattern generator is synchronized by loading 32 data stream bits into the receive pattern generator, and then checking the next 32 data stream bits. Synchronization is achieved if all 32 bits match the incoming pattern. If at least is incoming bits in the current 64-bit window do not match the receive pattern generator, automatic pattern resynchronization is initiated. Automatic pattern resynchronization can be disabled.

Figure 9-9. PRBS Synchronization State Diagram

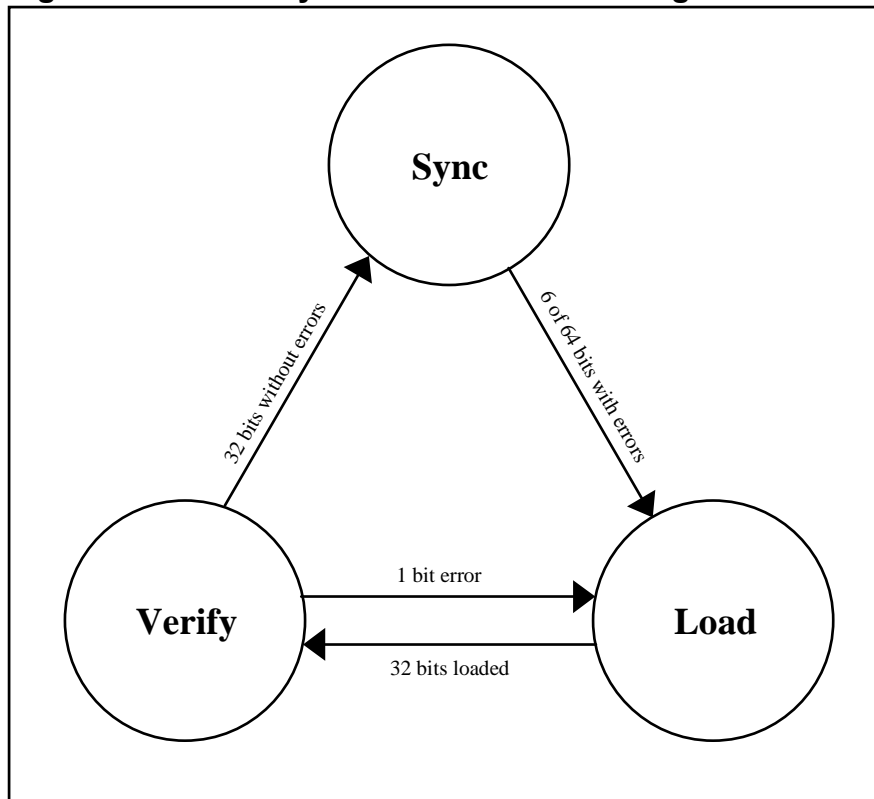

9.16.2 Repetitive Pattern Synchronization

Repetitive pattern synchronization synchronizes the receive pattern generator to the incoming repetitive pattern. The receive pattern generator is synchronized by searching each incoming data stream bit position for the repetitive pattern, and then checking the next 32 data stream bits. Synchronization is achieved if all 32 bits match the incoming pattern. If at least six incoming bits in the current 64-bit window do not match the receive PRBS pattern generator, automatic pattern resynchronization is initiated. Automatic pattern resynchronization can be disabled.

Figure 9-10. Repetitive Pattern Synchronization State Diagram

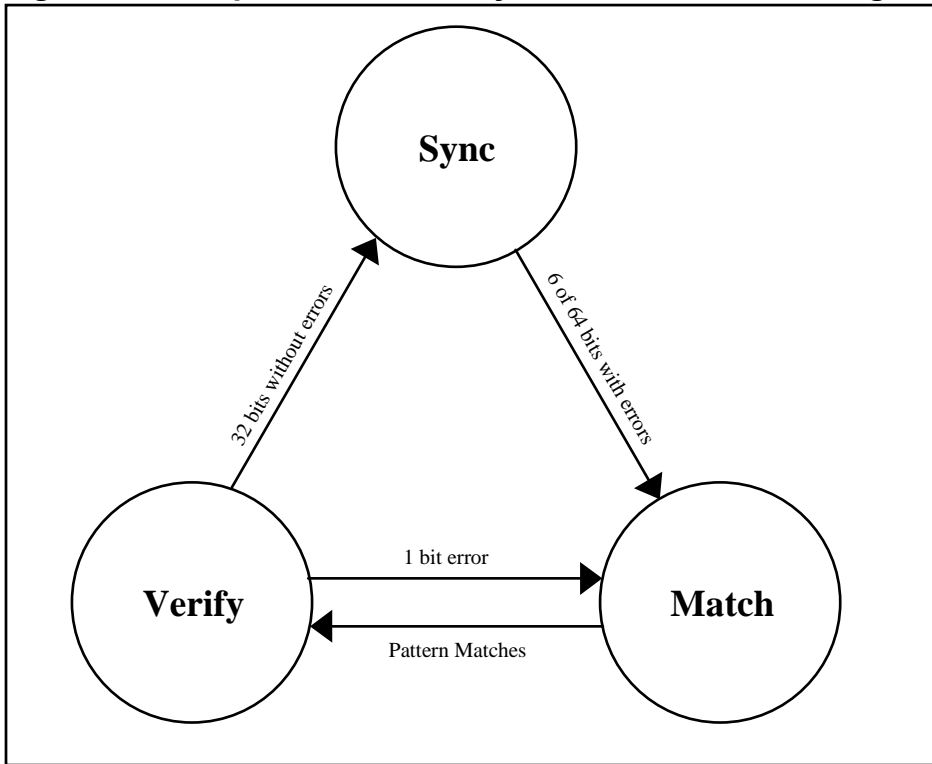

9.16.3 Pattern Monitoring

Pattern monitoring monitors the incoming data stream for Out Of Synchronization (OOS) condition, bit errors, and counts the incoming bits. An OOS condition is declared when the synchronization state machine is not in the "Sync" state. An OOS condition is terminated when the synchronization state machine is in the "Sync" state.

Bit errors are determined by comparing the incoming data stream bit to the receive pattern generator output. If they do not match, a bit error is declared, and the bit error and bit counts are incremented. If they match, only the bit count is incremented. The bit count and bit error count are not incremented when an OOS condition exists.

9.16.4 Pattern Generation

Pattern Generation generates the outgoing test pattern, and passes it onto Error Insertion. The transmit pattern generator is a 32-bit shift register that shifts data from the least significant bit (LSB) or bit 1 to the most significant bit (MSB) or bit 32. The input to bit 1 is the feedback. For a PRBS pattern (generating polynomial $x^n + x^y + 1$), the feedback is an XOR of bit n and bit y . For a repetitive pattern (length n), the feedback is bit n . The values for n and y are individually programmable. The output of the receive pattern generator is the feedback. If QRSS is enabled, the feedback is an XOR of bits 17 and 20, and the output is forced to one if the next 14 bits are all zeros. QRSS is programmable (on or off). For PRBS and QRSS patterns, the feedback is forced to one if bits 1 through 31 are all zeros. When a new pattern is loaded, the pattern generator is loaded with a pattern value before pattern generation starts. The pattern value is programmable ($0 - 2^n - 1$). When PRBS and QRSS patterns are generated the seed value is all ones.

9.16.4.1 Error Insertion

Error insertion inserts errors into the outgoing pattern data stream. Errors are inserted one at a time. Single bit error insertion can be initiated from the microprocessor interface. If pattern inversion is enabled, the data stream is inverted before the overhead/stuff bits are inserted. Pattern inversion is programmable (on or off).

9.16.4.2 Performance Monitoring Update

All counters stop counting at their maximum count. A counter register is updated by asserting (low to high transition) the performance monitoring update signal (PMU). During the counter register update process, the performance monitoring status signal (PMS) is de-asserted. The counter register update process consists of loading the counter register with the current count, resetting the counter, forcing the zero count status indication low for one clock cycle, and then asserting PMS. No events shall be missed during an update procedure.

9.17 Transmit Packet Processor

The Transmit Packet Processor accepts data from the Transmit FIFO, performs bit reordering, FCS processing, packet error insertion, stuffing, packet abort sequence insertion, inter-frame padding, and packet scrambling. The data output from the Transmit Packet Processor to the Transmit Serial Interface is a serial data stream (bit synchronous mode). HDLC processing can be disabled (clear channel enable). Disabling HDLC processing disables FCS processing, packet error insertion, stuffing, packet abort sequence insertion, and inter-frame padding. Only bit reordering and packet scrambling are not disabled.

Bit reordering changes the bit order of each byte. If bit reordering is disabled, the outgoing 8-bit data stream DT[1:8] with DT[1] being the MSB and DT[8] being the LSB is output from the Transmit FIFO with the MSB in TFD[7] (or 15, 23, or 31) and the LSB in TFD[0] (or 8, 16, or 24) of the transmit FIFO data TFD[7:0] 15:8, 23:16, or 31:24). If bit reordering is enabled, the outgoing 8-bit data stream DT[1:8] is output from the Transmit FIFO with the MSB in TFD[0] and the LSB in TFD[7] of the transmit FIFO data TFD[7:0]. In bit synchronous mode, DT [1] is the first bit transmitted.

FCS processing calculates an FCS and appends it to the packet. FCS calculation is a CRC-16 or CRC-32 calculation over the entire packet. The polynomial used for FCS-16 is $x^{16} + x^{12} + x^5 + 1$. The polynomial used for FCS-32 is $x^{32} + x^{26} + x^{23} + x^{22} + x^{16} + x^{12} + x^{11} + x^{10} + x^8 + x^7 + x^5 + x^4 + x^2 + x + 1$. The FCS is inverted after calculation. The FCS type is programmable. If FCS append is enabled, the calculated FCS is appended to the packet. If FCS append is disabled, the packet is transmitted without an FCS. The FCS append mode is programmable. If packet processing is disabled, FCS processing is not performed.

Packet error insertion inserts errors into the FCS bytes. A single FCS bit is corrupted in each errored packet. The FCS bit corrupted is changed from errored packet to errored packet. Error insertion can be controlled by a register or by the manual error insertion input ([LI.TMEI.TMEI](#)). The error insertion initiation type (register or input) is programmable. If a register controls error insertion, the number and frequency of the errors are programmable. If FCS append is disabled, packet error insertion will not be performed. If packet processing is disabled, packet error insertion is not performed.

Stuffing inserts control data into the packet to prevent packet data from mimicking flags. A packet start indication is received, and stuffing is performed until, a packet end indication is received. Bit stuffing consists of inserting a '0' directly following any five contiguous '1's. If packet processing is disabled, stuffing is not performed.

There is at least one flag plus a programmable number of additional flags between packets. The inter-frame fill can be flags or all '1's followed by a start flag. If the inter-frame fill is all '1's, the number of '1's between the end and start flags does not need to be an integer number of bytes, however, there must be at least 15 consecutive '1's between the end and start flags. The inter-frame padding type is programmable. If packet processing is disabled, inter-frame padding is not performed.

Packet abort insertion inserts a packet abort sequences as necessary. If a packet abort indication is detected, a packet abort sequence is inserted and inter-frame padding is done until a packet start flag is detected. The abort sequence is FFh. If packet processing is disabled, packet abort insertion is not performed.

The packet scrambler is a $x^{43} + 1$ scrambler that scrambles the entire packet data stream. The packet scrambler runs continuously, and is never reset. In bit synchronous mode, scrambling is performed one bit at a time. In byte synchronous mode, scrambling is performed 8 bits at a time. Packet scrambling is programmable.

Once all packet processing has been completed serial data stream is passed on to the Transmit Serial Interface.

9.18 Receive Packet Processor

The Receive Packet Processor accepts data from the Receive Serial Interface performs packet descrambling, packet delineation, inter-frame fill filtering, packet abort detection, destuffing, packet size checking, FCS error monitoring, FCS byte extraction, and bit reordering. The data coming from the Receive Serial Interface is a serial data stream. Packet processing can be disabled (clear channel enable). Disabling packet processing disables packet delineation, inter-frame fill filtering, packet abort detection, destuffing, packet size checking, FCS error monitoring, and FCS byte extraction. Only packet descrambling and bit reordering are not disabled.

The packet descrambler is a self-synchronous $x^{43} + 1$ descrambler that descrambles the entire packet data stream. Packet descrambling is programmable. The descrambler runs continuously, and is never reset. The descrambling is performed one bit at a time. Packet descrambling is programmable. If packet processing is disabled, the serial data stream is demultiplexed in to an 8-bit data stream before being passed on.

If packet processing is disabled, a packet boundary is arbitrarily chosen and the data is divided into "packets" of programmable size (dependent on maximum packet size setting). These packets are then passed on to bit reordering with packet start and packet end indications. Data then bypasses packet delineation, inter-frame fill filtering, packet abort detection, destuffing, packet size checking, FCS error monitoring, and FCS byte extraction.

Packet delineation determines the packet boundary by identifying a packet start or end flag. Each time slot is checked for a flag sequence (7Eh). Once a flag is found, it is identified as a start/end flag and the packet boundary is set. The flag check is performed one bit at a time. If packet processing is disabled, packet delineation is not performed.

Inter-frame fill filtering removes the inter-frame fill between packets. When a packet end flag is detected, all data is discarded until a packet start flag is detected. The inter-frame fill can be flags or all '1's. The number of '1's between flags does not need to be an integer number of bytes, and if at least 7 '1's are detected in the first 16 bits after a flag, all data after the flag is discarded until a start flag is detected. There may be only one flag between packets. When the inter-frame fill is flags, the flags may have a shared zero (01111101111110). If there is less than 16 bits between two flags, the data is discarded. If packet processing is disabled, inter-frame fill filtering is not performed.

Packet abort detection searches for a packet abort sequence. Between a packet start flag and a packet end flag, if an abort sequence is detected, the packet is marked with an abort indication, the aborted packet count is incremented, and all subsequent data is discarded until a packet start flag is detected. The abort sequence is seven consecutive ones. If packet processing is disabled, packet abort detection is not performed.

Destuffing removes the extra data inserted to prevent data from mimicking a flag or an abort sequence. A start flag is detected, a packet start is set, the flag is discarded, destuffing is performed until an end flag is detected, a packet end is set, and the flag is discarded. In bit synchronous mode, bit destuffing is performed. Bit destuffing consists of discarding any '0' that directly follows five contiguous '1's. After destuffing is completed, the serial bit stream is demultiplexed into an 8-bit parallel data stream and passed on with packet start, packet end, and packet abort indications. If there is less than eight bits in the last byte, an invalid packet flag is raised, the packet is tagged with an abort indication, and the packet size violation count is incremented. If packet processing is disabled, destuffing is not performed.

Packet size checking checks each packet for a programmable maximum and programmable minimum size. As the packet data comes in, the total number of bytes is counted. If the packet length is below the minimum size limit, the packet is marked with an aborted indication, and the packet size violation count is incremented. If the packet length is above the maximum size limit, the packet is marked with an aborted indication, the packet size violation count is incremented, and all packet data is discarded until a packet start is received. The minimum and maximum lengths include the FCS bytes, and are determined after destuffing has occurred. If packet processing is disabled, packet size checking is not performed.

FCS error monitoring checks the FCS and aborts errored packets. If an FCS error is detected, the FCS errored packet count is incremented and the packet is marked with an aborted indication. If an FCS error is not detected, the receive packet count is incremented. The FCS type (16-bit or 32-bit) is programmable. If FCS processing or packet processing is disabled, FCS error monitoring is not performed.

FCS byte extraction discards the FCS bytes. If FCS extraction is enabled, the FCS bytes are extracted from the packet and discarded. If FCS extraction is disabled, the FCS bytes are stored in the receive FIFO with the packet. If FCS processing or packet processing is disabled, FCS byte extraction is not performed.

Bit reordering changes the bit order of each byte. If bit reordering is disabled, the incoming 8-bit data stream DT[1:8] with DT[1] being the MSB and DT[8] being the LSB is output to the Receive FIFO with the MSB in RFD[7] (or 15, 23, or 31) and the LSB in RFD[0] (or 8, 16, or 24) of the receive FIFO data RFD[7:0] (or 15:8, 23:16, or 31:24). If bit reordering is enabled, the incoming 8-bit data stream DT[1:8] is output to the Receive FIFO with the MSB in RFD[0] and the LSB in RFD[7] of the receive FIFO data RFD[7:0]. DT[1] is the first bit received from the incoming data stream.

Once all of the packet processing has been completed, The 8-bit parallel data stream is demultiplexed into a 32-bit parallel data stream. The Receive FIFO data is passed on to the Receive FIFO with packet start, packet end, packet abort, and modulus indications. At a packet end, the 32-bit word may contain 1, 2, 3, or 4 bytes of data depending on the number of bytes in the packet. The modulus indications indicate the number of bytes in the last data word of the packet.

Figure 9-11. HDLC Encapsulation of MAC Frame

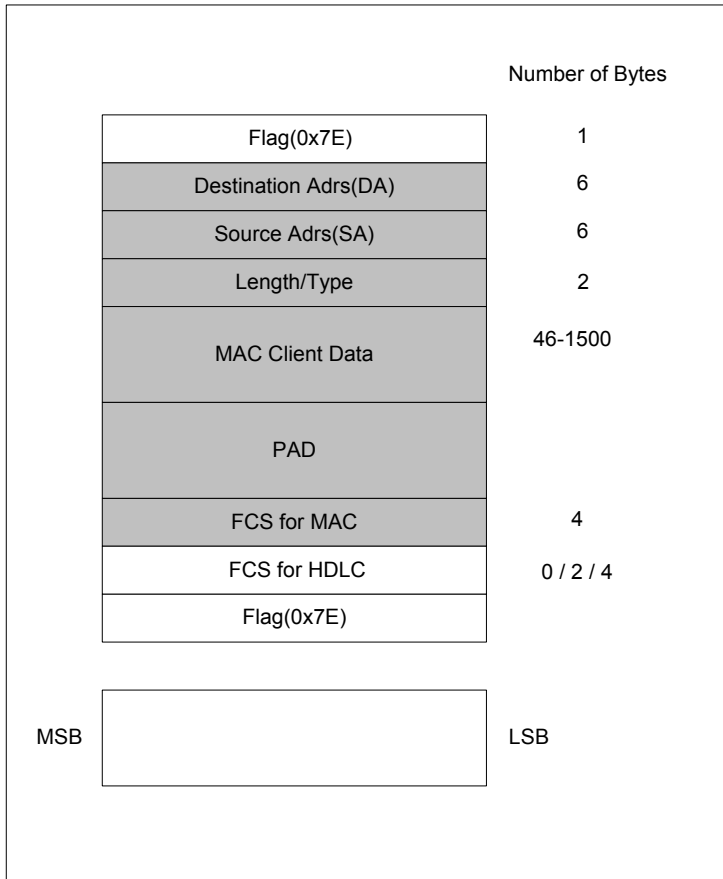

9.19 X.86 Encoding and Decoding

X.86 protocol provides a method for encapsulating Ethernet Frame onto LAPS. LAPS provides HDLC type framing structure for encapsulation of Ethernet frames. LAPS encapsulated frames can be used to send data onto a SONET/SDH network. The DS33R11 expects a byte synchronization signal to provide the byte boundary for the X.86 receiver. This is provided by the RBSYNC pin. The functional timing is shown in [Figure 12-4](#). The X.86 transmitter provides a byte boundary indicator with the signal TBSYNC. The functional timing is shown in [Figure 12-3](#). Note that in some cases, additional logic may be required to meet RSYNC/TSYNC synchronization timing requirements when operating in X.86 mode.

Figure 9-12. LAPS Encoding of MAC Frames Concept

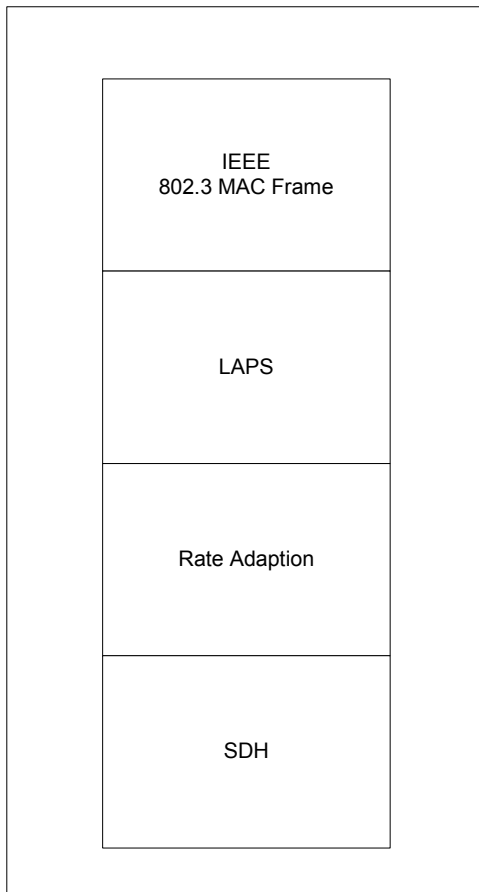
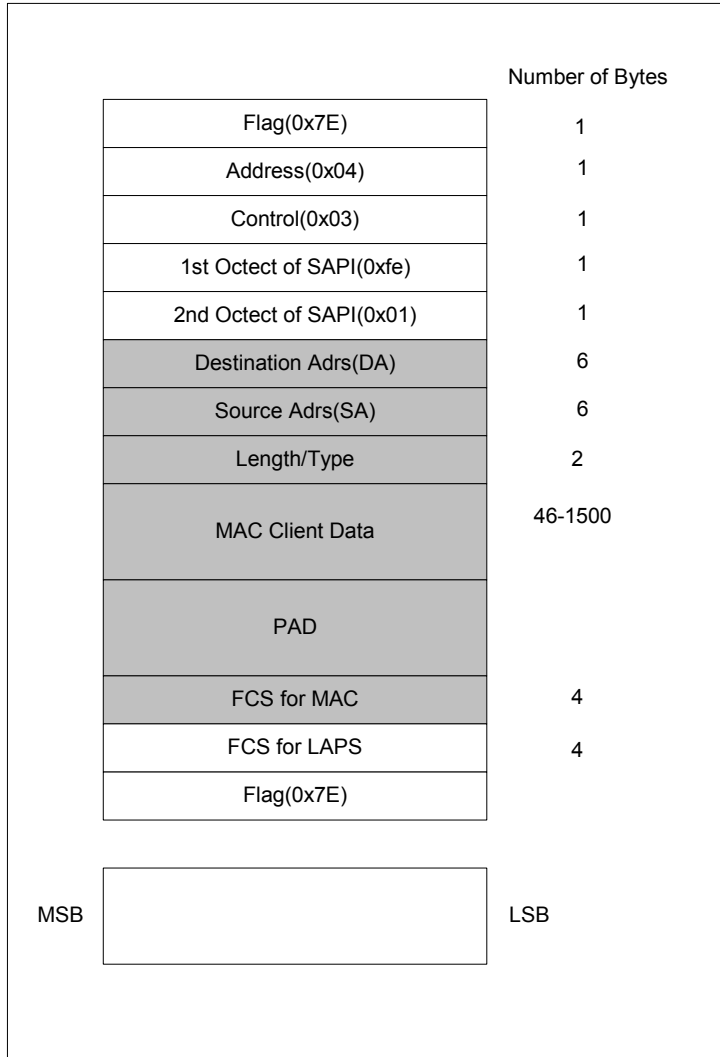

Figure 9-13. X.86 Encapsulation of the MAC frame

The DS33R11 will encode the MAC Frame with the LAPS encapsulation on a complete serial stream if configured for X.86 mode in the register [LI.TX86E](#). The DS33R11 provides the following functions:

- Control Registers for Address, Control, SAPIH, SAPIL.
- 32 bit FCS enabled.
- Programmable $X^{43}+1$ scrambling.

The sequence of processing performed by the receiver is as follows:

- Programmable octets $X^{43}+1$ descrambling.
- Detect the Start Flag (7E).
- Remove Rate adaptation octets 7d, dd.
- Perform transparency-processing 7d, 5e is converted to 7e and 7d, 5d is converted to 7d.
- Check for a valid Address, Control and SAPI fields ([LI.TRX86A](#) to [LI.TRX86SAPIL](#)).
- Perform FCS checking.
- Detect the closing flag.

The X86 received frame is aborted if:

- If 7d,7E is detected. This is an abort packet sequence in X.86.
- Invalid FCS is detected.
- The received frame has less than 6 octets.
- Control, SAPI and address field are mismatched to the programmed value.
- Octet 7d and octet other than 5d,5e,7e or dd is detected.

For the transmitter if X.86 is enabled the sequence of processing is as follows:

- Construct frame including start flag, SAPI, Control and MAC frame.
- Calculate FCS.
- Perform transparency processing - 7E is translated to 7D5E, 7D is translated to 7D5D.
- Append the end flag(7E).
- Scramble the sequence $X^{43}+1$.

Note that the serial transmit and receive registers apply to the X.86 implementations with specific exceptions. The exceptions are outlined in the serial interface transmit and receive register sections.

9.20 Committed Information Rate Controller

The DS33R11 provides a CIR provisioning facility. The CIR can be used to restrict the transport of received MAC data to a programmable rate. The CIR location is shown in [Figure 6-1](#). The CIR will restrict the data flow from the Receive MAC to Transmit HDLC. This can be used for provisioning and billing functions towards the WAN. The user must set the CIR register to control the amount of data throughput from the MAC to HDLC transmit. The CIR register is in granularity of 500kbit/s with a range of 0 to 52Mbit/s. The operation of the CIR is as follows:

- The CIR block counts the credits that are accumulated at the end of every 125ms.
- If data is received and stored in the SDRAM to be sent to the Serial Interface, the interface will request the data if there is a positive credit balance. If the credit balance is negative, transmit interface does not request data.
- New credit balance is calculated $\text{credit balance} = \text{old credit balance} - \text{frame size in bytes}$ after the frame is sent.
- The credit balance is incremented every 125ms by $\text{CIR}/8$.
- Credit balances not used in 250ms are reset to 0.
- The maximum value of CIR can not exceed the transmit line rate.
- If the data rate received from the Ethernet interface is higher than the CIR, the receive queue buffers will fill and the high threshold water mark will invoke flow control to reduce the incoming traffic rate.
- The CIR function is only available for software mode of operation only.
- CIR function is only available in data received at the Ethernet Interface to be sent to WAN. There is not CIR functionality for data arriving from the WAN to be sent to the Ethernet Interface.
- Negative credits are not allowed, if there is not a credit balance, no frames are sent until there is a credit balance again.

10 INTEGRATED T1/E1/J1 TRANSCEIVER

10.1 T1/E1/J1 Clocks

Figure 10-1 shows the clock map of the T1/E1 transceiver. The routing for the transmit and receive clocks are shown for the various loopback modes and jitter attenuator positions. Although there is only one jitter attenuator, which can be placed in the receive or transmit path, two are shown for simplification and clarity.

Figure 10-1. T1/E1/J1 Clock Map

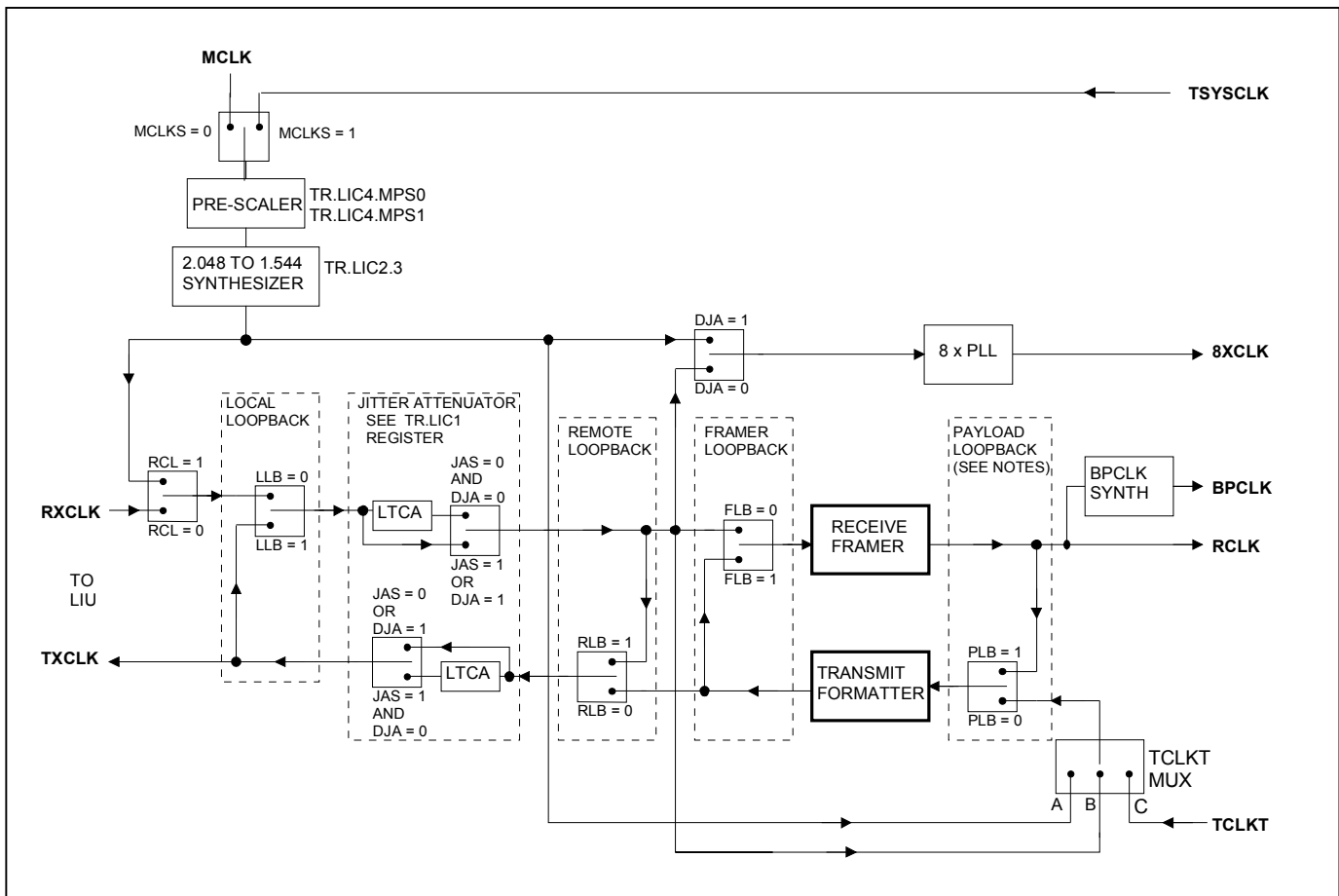

The TCLKT MUX is dependent on the state of the TCSS0 and TCSS1 bits in the TR.CCR1 register and the state of the TCLKT pin.

Table 10-1. T1/E1/J1 Transmit Clock Source

TCSS1	TCSS0	TRANSMIT CLOCK SOURCE
0	0	The TCLKT pin (C) is always the source of transmit clock.
0	1	Switch to the recovered clock (B) when the signal at the TCLKT pin fails to transition after one channel time.
1	0	Use the scaled signal (A) derived from MCLK as the transmit clock. The TCLKT pin is ignored.
1	1	Use the recovered clock (B) as the transmit clock. The TCLKT pin is ignored.

10.2 Per-Channel Operation

Some of the features described in the data sheet that operate on a per-channel basis use a special method for channel selection. There are five registers involved: per-channel pointer register (TR.PCPR) and per-channel data registers 1–4 (TR.PCDR1–4). The user selects which function or functions are to be applied on a per-channel basis by setting the appropriate bit(s) in the TR.PCPR register. The user then writes to the TR.PCDR registers to select the channels for that function. The following is an example of mapping the transmit and receive BERT function to channels 9–12, 20, and 21.

```
Write 11h to TR.PCPR
Write 00h to TR.PCDR1
Write 0fh to TR.PCDR2
Write 18h to TR.PCDR3
Write 00h to TR.PCDR4
```

The user may write to the TR.PCDR1-4 with multiple functions in the TR.PCPR register selected, but can only read the values from the TR.PCDR1-4 registers for a single function at a time. More information about how to use these per-channel features can be found in the [TR.PCPR](#) register.

10.3 T1/E1/J1 Transceiver Interrupts

Various alarms, conditions, and events in the T1/E1/J1 transceiver can cause interrupts. For simplicity, these are all referred to as events in this explanation. All status registers can be programmed to produce interrupts. Each status register has an associated interrupt mask register. For example, TR.SR1 (status register 1) has an interrupt control register called TR.IMR1 (interrupt mask register 1). Status registers are the only sources of interrupts in the device. On power-up, all writeable registers of the T1/E1/J1 transceiver are automatically cleared. Since bits in the TR.IMRx registers have to be set = 1 to allow a particular event to cause an interrupt, no interrupts can occur until the host selects which events are to produce interrupts. Since there are potentially many sources of interrupts on the device, several features are available to help sort out and identify which event is causing an interrupt. When an interrupt occurs, the host should first read the TR.IIR1 and TR.IIR2 registers (interrupt information registers) to identify which status register (or registers) is producing the interrupt. Once that is determined, the individual status register or registers can be examined to determine the exact source.

Once an interrupt has occurred, the interrupt handler routine should set the INTDIS bit (TR.CCR3.6) to stop further activity on the interrupt pin. After all interrupts have been determined and processed, the interrupt handler routine should re-enable interrupts by setting the INTDIS bit = 0.

Note that the integrated Ethernet Mapper also generates interrupts, as discussed in Section [9.6](#).

10.4 T1 Framer/Formatter Control and Status

The T1 framer portion of the transceiver is configured through a set of nine control registers. Typically, the control registers are only accessed when the system is first powered up. Once the transceiver has been initialized, the control registers only need to be accessed when there is a change in the system configuration. There are two receive control registers (TR.T1RCR1 and TR.T1RCR2), two transmit control registers (TR.T1TCR1 and TR.T1TCR2), and a common control register (TR.T1CCR1). Each of these registers is described in this section.

10.4.1 T1 Transmit Transparency

The software signaling insertion-enable registers, TR.SSIE1–TR.SSIE4, can be used to select signaling insertion from the transmit signaling registers, TS1–TS12, on a per-channel basis. Setting a bit in the SSIE_x register allows signaling data to be sourced from the signaling registers for that channel.

In transparent mode, bit 7 stuffing and/or robbed-bit signaling is prevented from overwriting the data in the channels. If a DS0 is programmed to be clear, no robbed-bit signaling is inserted nor does the channel have bit 7 stuffing performed. However, in the D4 framing mode, bit 2 is overwritten by a 0 when a Yellow Alarm is transmitted. Also, the user has the option to globally override the TR.SSIE_x registers from determining which channels are to have bit 7 stuffing performed. If the TR.T1TCR1.3 and TR.T1TCR2.0 bits are set to 1, then all 24 T1 channels have bit 7 stuffing performed on them, regardless of how the TR.SSIE_x registers are programmed. In this manner, the TR.SSIE_x registers are only affecting the channels that are to have robbed-bit signaling inserted into them.

10.4.2 AIS-CI and RAI-CI Generation and Detection

The device can transmit and detect the RAI-CI and AIS-CI codes in T1 mode. These codes are compatible with and do not interfere with the standard RAI (Yellow) and AIS (Blue) alarms. These codes are defined in ANSI T1.403.

The AIS-CI code (alarm indication signal-customer installation) is the same for both ESF and D4 operation. Setting the TAIS-CI bit in the TR.T1CCR1 register and the TBL bit in the TR.T1TCR1 register causes the device to transmit the AIS-CI code. The RAIS-CI status bit in the TR.SR4 register indicates the reception of an AIS-CI signal.

The RAI-CI (remote alarm indication-customer installation) code for T1 ESF operation is a special form of the ESF Yellow Alarm (an unscheduled message). Setting the RAIS-CI bit in the TR.T1CCR1 register causes the device to transmit the RAI-CI code. The RAI-CI code causes a standard Yellow Alarm to be detected by the receiver. When the host processor detects a Yellow Alarm, it can then test the alarm for the RAI-CI state by checking the BOC detector for the RAI-CI flag. That flag is a 011111 code in the 6-bit BOC message.

The RAI-CI code for T1 D4 operation is a 10001011 flag in all 24 time slots. To transmit the RAI-CI code the host sets all 24 channels to idle with a 10001011 idle code. Since this code meets the requirements for a standard T1 D4 Yellow Alarm, the host can use the receive channel monitor function to detect the 100001011 code whenever a standard Yellow Alarm is detected.

10.4.3 T1 Receive-Side Digital-Milliwatt Code Generation

Receive-side digital-milliwatt code generation involves using the receive digital-milliwatt registers (TR.T1RDMR1/2/3) to determine which of the 24 T1 channels of the T1 line going to the backplane should be overwritten with a digital-milliwatt pattern. The digital-milliwatt code is an 8-byte repeating pattern that represents a 1kHz sine wave (1E/0B/0B/1E/9E/8B/8B/9E). Each bit in the TR.T1RDMRx registers represents a particular channel. If a bit is set to a 1, then the receive data in that channel is replaced with the digital-milliwatt code. If a bit is set to 0, no replacement occurs.

Table 10-2. T1 Alarm Criteria

ALARM	SET CRITERIA	CLEAR CRITERIA
Blue Alarm (AIS) (Note 1)	When over a 3ms window, five or fewer 0s are received	When over a 3ms window, six or more 0s are received
Yellow Alarm (RAI) D4 Bit 2 Mode (TR.T1RCR2.0 = 0)	When bit 2 of 256 consecutive channels is set to 0 for at least 254 occurrences	When bit 2 of 256 consecutive channels is set to 0 for fewer than 254 occurrences
D4 12th F-Bit Mode (TR.T1RCR2.0 = 1; this mode is also referred to as the “Japanese Yellow Alarm”)	When the 12th framing bit is set to 1 for two consecutive occurrences	When the 12th framing bit is set to 0 for two consecutive occurrences
ESF Mode	When 16 consecutive patterns of 00FF appear in the FDL	When 14 or fewer patterns of 00FF hex out of 16 possible appear in the FDL
Red Alarm (LRCL) (Also referred to as loss of signal)	When 192 consecutive 0s are received	When 14 or more 1s out of 112 possible bit positions are received

Note 1: The definition of Blue Alarm (or AIS) is an unframed all-ones signal. Blue Alarm detectors should be able to operate properly in the presence of a 10E-3 error rate and they should not falsely trigger on a framed all-1s signal. Blue Alarm criteria in the device has been set to achieve this performance. It is recommended that the RBL bit be qualified with the RLOS bit.

Note 2: ANSI specifications use a different nomenclature than this document. The following terms are equivalent:

RBL = AIS
RCL = LOS
RLOS = LOF
RYEL = RAI

10.5 E1 Framer/Formatter Control and Status

The E1 framer portion of the transceiver is configured by a set of four control registers. Typically, the control registers are only accessed when the system is first powered up. Once the device has been initialized, the control registers need only to be accessed when there is a change in the system configuration. There are two receive control registers (TR.E1RCR1 and TR.E1RCR2) and two transmit control registers (TR.E1TCR1 and TR.E1TCR2). There are also four status and information registers. Each of these eight registers is described in this section.

Table 10-3. E1 Sync/Resync Criteria

FRAME OR MULTIFRAME LEVEL	SYNC CRITERIA	RESYNC CRITERIA	ITU SPEC.
FAS	FAS present in frame N and N + 2; FAS not present in frame N + 1	Three consecutive incorrect FAS received Alternate: (TR.E1RCR1.2 = 1) The above criteria is met or three consecutive incorrect bit 2 of non-FAS received	G.706 4.1.1 4.1.2
CRC4	Two valid MF alignment words found within 8ms	915 or more CRC4 codewords out of 1000 received in error	G.706 4.2 and 4.3.2
CAS	Valid MF alignment word found and previous time slot 16 contains code other than all 0s	Two consecutive MF alignment words received in error	G.732 5.2

10.5.1 Automatic Alarm Generation

The device can be programmed to automatically transmit AIS or remote alarm. When automatic AIS generation is enabled (TR.E1TCR2.1 = 1), the device monitors the receive-side framer to determine if any of the following conditions are present: loss-of-receive frame synchronization, AIS alarm (all ones) reception, or loss-of-receive carrier (or signal). The framer forces either an AIS or remote alarm if any one or more of these conditions is present.

When automatic RAI generation is enabled (TR.E1TCR2.0 = 1), the framer monitors the receive side to determine if any of the following conditions are present: loss-of-receive-frame synchronization, AIS alarm (all ones) reception, loss-of-receive carrier (or signal), or if CRC4 multiframe synchronization cannot be found within 128ms of FAS synchronization (if CRC4 is enabled). If any one or more of these conditions is present, then the framer transmits an RAI alarm. RAI generation conforms to ETS 300 011 specifications and a constant remote alarm is transmitted if the device cannot find CRC4 multiframe synchronization within 400ms as per G.706.

Note: It is an invalid state to have both automatic AIS generation and automatic remote alarm generation enabled at the same time.

Table 10-4. E1 Alarm Criteria

ALARM	SET CRITERIA	CLEAR CRITERIA	ITU SPECIFICATION
RLOS	An RLOS condition exists on power-up prior to initial synchronization, when a resync criteria has been met, or when a manual resync has been initiated by TR.E1RCR1.0		
RCL	255 or 2048 consecutive 0s received as determined by TR.E1RCR2.0	At least 32 1s in 255-bit times are received	G.775/G.962
RRA	Bit 3 of nonalign frame set to 1 for three consecutive occasions	Bit 3 of nonalign frame set to 0 for three consecutive occasions	O.162 2.1.4
RUA1	Fewer than three 0s in two frames (512 bits)	More than two 0s in two frames (512 bits)	O.162 1.6.1.2
RDMA	Bit 6 of time slot 16 in frame 0 has been set for two consecutive multiframes		
V52LNK	Two out of three Sa7 bits are 0		G.965

10.6 Per-Channel Loopback

The per-channel loopback registers (PCLRs) determine which channels (if any) from the backplane should be replaced with the data from the receive side or, i.e., off of the T1 or E1 line. If this loopback is enabled, then transmit and receive clocks and frame syncs must be synchronized. One method to accomplish this is to connect RCLKO to TCLKT and RFSYNC to TSYNC. There are no restrictions on which channels can be looped back or on how many channels can be looped back.

Each of the bit positions in the per-channel loopback registers (TR.PCLR1/TR.PCLR2/TR.PCLR3/TR.PCLR4) represents a DS0 channel in the outgoing frame. When these bits are set to a 1, data from the corresponding receive channel replaces the data on TSER1 for that channel.

10.7 Error Counters

The transceiver contains four counters that are used to accumulate line-coding errors, path errors, and synchronization errors. Counter update options include one-second boundaries, 42ms (T1 mode only), 62ms (E1 mode only), or manual. See *Error-Counter Configuration Register (TR.ERCNT)*. When updated automatically, the user can use the interrupt from the timer to determine when to read these registers. All four counters saturate at their respective maximum counts, and they do not roll over. Note: Only the line-code violation count register has the potential to overflow, but the bit error would have to exceed 10E-2 before this would occur.

10.7.1 Line-Code Violation Counter (TR.LCVCR)

In T1 mode, code violations are defined as bipolar violations (BPVs) or excessive 0s. If the B8ZS mode is set for the receive side, then B8ZS codewords are not counted. This counter is always enabled; it is not disabled during receive loss-of-synchronization (RLOS = 1) conditions. [Table 10-5](#) shows what the LCVCRs count.

Table 10-5 T1 Line Code Violation Counting Options

COUNT EXCESSIVE ZEROS? (TR.ERCNT.0)	B8ZS ENABLED? (TR.T1RCR2.5)	COUNTED IN THE LCVCRs
No	No	BPVs
Yes	No	BPVs + 16 consecutive 0s
No	Yes	BPVs (B8ZS codewords not counted)
Yes	Yes	BPVs + 8 consecutive 0s

In E1 mode, either bipolar violations or code violations can be counted. Bipolar violations are defined as consecutive marks of the same polarity. In this mode, if the HDB3 mode is set for the receive side, then HDB3 codewords are not counted as BPVs. If TR.ERCNT.3 is set, then the LVC counts code violations as defined in ITU O.161. Code violations are defined as consecutive bipolar violations of the same polarity. In most applications, the framer should be programmed to count BPVs when receiving AMI code and to count CVs when receiving HDB3 code. This counter increments at all times and is not disabled by loss-of-sync conditions. The counter saturates at 65,535 and does not roll over. The bit-error rate on an E1 line would have to be greater than 10⁻² before the VCR would saturate ([Table 10-6](#)).

Table 10-6. E1 Line-Code Violation Counting Options

E1 CODE VIOLATION SELECT (TR.ERCNT.3)	COUNTED IN THE LCVCRs
0	BPVs
1	CVs

10.7.2 Path Code Violation Count Register (TR.PCVCR)

In T1 mode, the path code violation count register records Ft, Fs, or CRC6 errors in T1 frames. When the receive side of a framer is set to operate in the T1 ESF framing mode, TR.PCVCR records errors in the CRC6 codewords. When set to operate in the T1 D4 framing mode, TR.PCVCR counts errors in the Ft framing bit position. Through the TR.ERCNT.2 bit, a framer can be programmed to also report errors in the Fs framing bit position. The TR.PCVCR is disabled during receive loss-of-synchronization (RLOS = 1) conditions. [Table 10-7](#) shows what errors the TR.PCVCR counts.

Table 10-7. T1 Path Code Violation Counting Arrangements

FRAMING MODE	COUNT Fs ERRORS?	COUNTED IN THE PCVCRs
D4	No	Errors in the Ft pattern
D4	Yes	Errors in both the Ft and Fs patterns
ESF	Don't Care	Errors in the CRC6 codewords

In E1 mode, the path code violation-count register records CRC4 errors. Since the maximum CRC4 count in a one-second period is 1000, this counter cannot saturate. The counter is disabled during loss-of-sync at either the FAS or CRC4 level; it continues to count if loss-of-multiframe sync occurs at the CAS level.

Path code violation-count register 1 (TR.PCVCR1) is the most significant word and TR.PCVCR2 is the least significant word of a 16-bit counter that records path violations (PVs).

10.7.3 Frames Out-of-Sync Count Register (TR.FOSCR)

In T1 mode, TR.FOSCR is used to count the number of multiframes that the receive synchronizer is out of sync. This number is useful in ESF applications needing to measure the parameters loss-of-frame count (LOFC) and ESF error events as described in AT&T publication TR54016. When TR.FOSCR is operated in this mode, it is not disabled during receive loss-of-synchronization (RLOS = 1) conditions. TR.FOSCR has an alternate operating mode whereby it counts either errors in the Ft framing pattern (in the D4 mode) or errors in the FPS framing pattern (in the ESF mode). When TR.FOSCR is operated in this mode, it is disabled during receive loss-of-synchronization (RLOS = 1) conditions. [Table 10-8](#) shows what the FOSCR is capable of counting.

Table 10-8. T1 Frames Out-of-Sync Counting Arrangements

FRAMING MODE (TR.T1RCR1.3)	COUNT MOS OR F-BIT ERRORS (TR.ERCNT.1)	COUNTED IN THE FOSCRs
D4	MOS	Number of multiframes out-of-sync
D4	F-Bit	Errors in the Ft pattern
ESF	MOS	Number of multiframes out-of-sync
ESF	F-Bit	Errors in the FPS pattern

In E1 mode, TR.FOSCR counts word errors in the FAS in time slot 0. This counter is disabled when RLOS is high. FAS errors are not counted when the framer is searching for FAS alignment and/or synchronization at either the CAS or CRC4 multiframe level. Since the maximum FAS word error count in a one-second period is 4000, this counter cannot saturate.

The frames out-of-sync count register 1 (TR.FOSCR1) is the most significant word and TR.FOSCR2 is the least significant word of a 16-bit counter that records frames out-of-sync.

10.7.4 E-Bit Counter (TR.EBCR)

This counter is only available in E1 mode. E-bit count register 1 (TR.EBCR1) is the most significant word and TR.EBCR2 is the least significant word of a 16-bit counter that records far-end block errors (FEBE) as reported in the first bit of frames 13 and 15 on E1 lines running with CRC4 multiframe. These count registers increment once each time the received E-bit is set to 0. Since the maximum E-bit count in a one-second period is 1000, this counter cannot saturate. The counter is disabled during loss-of-sync at either the FAS or CRC4 level; it continues to count if loss-of-multiframe sync occurs at the CAS level.

10.8 DS0 Monitoring Function

The transceiver has the ability to monitor one DS0 64kbps channel in the transmit direction and one DS0 channel in the receive direction at the same time. In the transmit direction, the user determines which channel is to be monitored by properly setting the TCM0 to TCM4 bits in the TR.TDS0SEL register. In the receive direction, the RCM0 to RCM4 bits in the TR.RDS0SEL register need to be properly set. The DS0 channel pointed to by the TCM0 to TCM4 bits appear in the transmit DS0 monitor (TR.TDS0M) register. The DS0 channel pointed to by the RCM0 to RCM4 bits appear in the receive DS0 (TR.RDS0M) register. The TCM4 to TCM0 and RCM4 to RCM0 bits should be programmed with the decimal decode of the appropriate T1 or E1 channel. T1 channels 1 through 24 map to register values 0 through 23. E1 channels 1 through 32 map to register values 0 through 31. For example, if DS0 channel 6 in the transmit direction and DS0 channel 15 in the receive direction needed to be monitored, then the following values would be programmed into TR.TDS0SEL and TR.RDS0SEL:

TCM4 = 0	RCM4 = 0
TCM3 = 0	RCM3 = 1
TCM2 = 1	RCM2 = 1
TCM1 = 0	RCM1 = 1
TCM0 = 1	RCM0 = 0

10.9 Signaling Operation

There are two methods to access receive signaling data and provide transmit signaling data, processor-based (software-based) or hardware-based. Processor-based refers to access through the transmit and receive signaling registers RS1–RS16 and TS1–TS16. Hardware-based refers to the TSIG and RSIG pins. Both methods can be used simultaneously.

Figure 10-2. Simplified Diagram of Receive Signaling Path

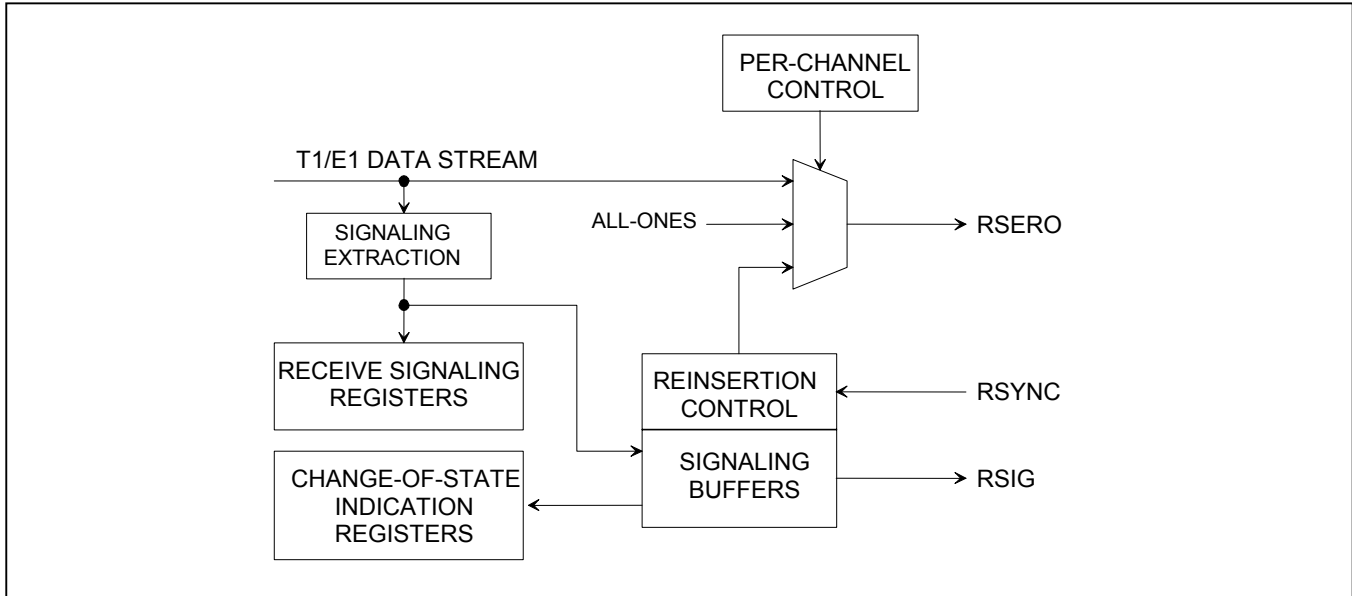

10.9.1 Processor-Based Receive Signaling

The robbed-bit signaling (T1) or TS16 CAS signaling (E1) is sampled in the receive data stream and copied into the receive signaling registers, RS1–RS16. In T1 mode, only RS1–RS12 are used. The signaling information in these registers is always updated on multiframe boundaries. This function is always enabled.

10.9.1.1 Change-of-State

To avoid constant monitoring of the receive signaling registers, the transceiver can be programmed to alert the host when any specific channel or channels undergo a change of their signaling state. TR.RSCSE1–TR.RSCSE4 for E1 and TR.RSCSE1–TR.RSCSE3 for T1 are used to select which channels can cause a change-of-state indication. The change-of-state is indicated in status register 5 (TR.SR1.5). If signaling integration (TR.CCR1.5) is enabled, then the new signaling state must be constant for three multiframes before a change-of-state is indicated. The user can enable the INT pin to toggle low upon detection of a change in signaling by setting the TR.IMR1.5 bit. The signaling integration mode is global and cannot be enabled on a channel-by-channel basis.

The user can identify which channels have undergone a signaling change-of-state by reading the TR.RSINFO1–TR.RSINFO4 registers. The information from these registers inform the user which TR.RSx register to read for the new signaling data. All changes are indicated in the TR.RSINFO1–TR.RSINFO4 registers regardless of the TR.RSCSE1–TR.RSCSE4 registers.

10.9.2 Hardware-Based Receive Signaling

In hardware-based signaling the signaling data can be obtained from the RSERO pin or the RSIG pin. RSIG is a signaling PCM stream output on a channel-by-channel basis from the signaling buffer. The signaling data, T1 robbed bit or E1 TS16, is still present in the original data stream at RSERO. The signaling buffer provides signaling data to the RSIG pin and also allows signaling data to be reinserted into the original data stream in a different alignment that is determined by a multiframe signal from the RSYNC pin. In this mode, the receive elastic store can be enabled or disabled. If the receive elastic store is enabled, then the backplane clock (RSYSCLK) can be either 1.544MHz or 2.048MHz. In the ESF framing mode, the ABCD signaling bits are output on RSIG in the lower nibble of each channel. The RSIG data is updated once a multiframe (3ms) unless a freeze is in effect. In the D4 framing mode, the AB signaling bits are output twice on RSIG in the lower nibble of each channel. Hence, bits 5 and 6 contain the same data as bits 7 and 8, respectively, in each channel. The RSIG data is updated once a multiframe (1.5ms) unless a freeze is in effect. See the timing diagrams in Section [12](#) for some examples.

10.9.2.1 Receive Signaling Reinsertion at RSERO

In this mode, the user provides a multiframe sync at the RSYNC pin and the signaling data is reinserted based on this alignment. In T1 mode, this results in two copies of the signaling data in the RSERO data stream, the original signaling data and the realigned data. This is of little consequence in voice channels. Reinsertion can be avoided in data channels since this feature is activated on a per-channel basis. In this mode, the elastic store must be enabled; however, the backplane clock can be either 1.544MHz or 2.048MHz.

Signaling reinsertion can be enabled on a per-channel basis by setting the RSRCS bit high in the TR.PCPR register. The channels that will have signaling reinserted are selected by writing to the TR.PCDR1–TR.PCDR3 registers for T1 mode and TR.PCDR1–TR.PCDR4 registers for E1 mode. In E1 mode, the user generally selects all channels or none for reinsertion. In E1 mode, signaling reinsertion on all channels can be enabled with a single bit, TR.SIGCR.7 (GRSRE). This bit allows the user to reinsert all signaling channels without having to program all channels through the per-channel function.

10.9.2.2 Force Receive Signaling All Ones

In T1 mode, the user can, on a per-channel basis, force the robbed-bit signaling bit positions to a 1 by using the per-channel register (Section [10.2](#)). The user sets the BTCS bit in the TR.PCPR register. The channels that will be forced to 1 are selected by writing to the TR.PCDR1–TR.PCDR3 registers.

10.9.2.3 Receive Signaling Freeze

The signaling data in the four multiframe signaling buffers is frozen in a known good state upon either a loss of synchronization (OOF event), carrier loss, or frame slip. This action meets the requirements of BellCore TR-TSY-000170 for signaling freezing. To allow this freeze action to occur, the RFE control bit (TR.SIGCR.4) should be set high. The user can force a freeze by setting the RFF control bit (TR.SIGCR.3) high. The RSIGF output pin provides a hardware indication that a freeze is in effect. The four-multiframe buffer provides a three-multiframe delay in the signaling bits provided at the RSIG pin (and at the RSERO pin if receive signaling reinsertion is enabled). When freezing is enabled (RFE = 1), the signaling data is held in the last-known good state until the corrupting error condition subsides. When the error condition subsides, the signaling data is held in the old state for at least an additional 9ms (or 4.5ms in D4 framing mode) before updating with new signaling data.

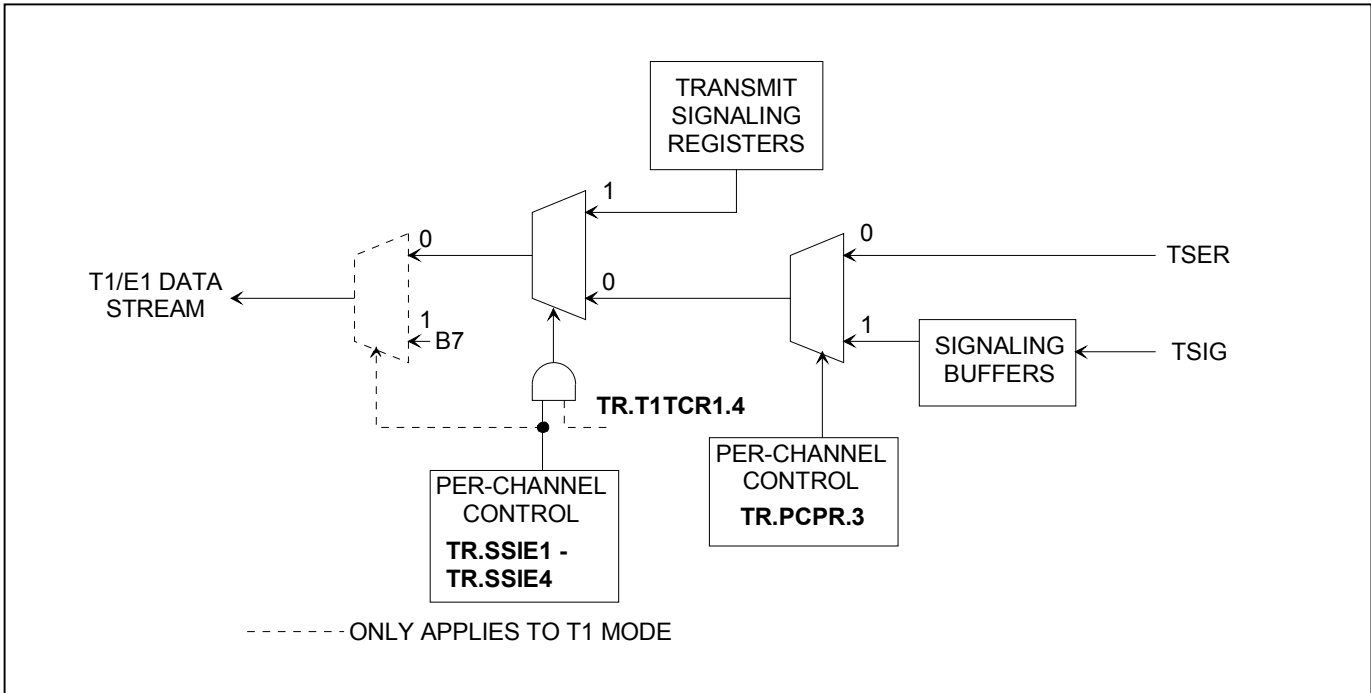
Figure 10-3. Simplified Diagram of Transmit Signaling Path

10.9.3 Processor-Based Transmit Signaling

In processor-based mode, signaling data is loaded into the transmit signaling registers (TS1–TS16) by the host interface. On multiframe boundaries, the contents of these registers are loaded into a shift register for placement in the appropriate bit position in the outgoing data stream. The user can employ the transmit multiframe interrupt in status register 4 (TR.SR4.4) to know when to update the signaling bits. The user need not update any transmit signaling register for which there is no change-of-state for that register.

Each transmit signaling register contains the robbed-bit signaling (T1) or TS16 CAS signaling (E1) for two time slots that are inserted into the outgoing stream, if enabled to do so through TR.T1TCR1.4 (T1 mode) or TR.E1TCR1.6 (E1 mode). In T1 mode, only TS1–TS12 are used.

Signaling data can be sourced from the TR.TS registers on a per-channel basis by using the software signaling insertion enable registers, TR.SSIE1–TR.SSIE4.

10.9.3.1 T1 Mode

In T1 ESF framing mode, there are four signaling bits per channel (A, B, C, and D). TS1–TS12 contain a full multiframe of signaling data. In T1 D4 framing mode, there are only two signaling bits per channel (A and B). In T1 D4 framing mode, the framer uses the C and D bit positions as the A and B bit positions for the next multiframe. In D4 mode, two multiframes of signaling data can be loaded into TS1–TS12. The framer loads the contents of TS1–TS12 into the outgoing shift register every other D4 multiframe. In D4 mode, the host should load new contents into TS1–TS12 on every other multiframe boundary and no later than 120µs after the boundary. In T1 mode, only registers TR.SSIE1–TR.SSIE3 are used since there are only 24 channels in a T1 frame.

10.9.3.2 E1 Mode

In E1 mode, TS16 carries the signaling information. This information can be in either CCS (common channel signaling) or CAS (channel associated signaling) format. The 32 time slots are referenced by two different channel number schemes in E1. In “Channel” numbering, TS0–TS31 are labeled channels 1 through 32. In “Phone Channel” numbering, TS1–TS15 are labeled channel 1 through channel 15 and TS17–TS31 are labeled channel 15 through channel 30. In E1 CAS mode, the CAS signaling alignment/alarm byte can be sourced from the transmit signaling registers along with the signaling data.

Table 10-9. Time Slot Numbering Schemes

TS	0	1	2	3	4	5	6	7	8	9	10	11	12	13	14	15	16	17	18	19	20	21	22	23	24	25	26	27	28	29	30	31
Channel	1	2	3	4	5	6	7	8	9	10	11	12	13	14	15	16	17	18	19	20	21	22	23	24	25	26	27	28	29	30	31	32
Phone Channel		1	2	3	4	5	6	7	8	9	10	11	12	13	14	15		16	17	18	19	20	21	22	23	24	25	26	27	28	29	30

10.9.4 Hardware-Based Transmit Signaling

In hardware-based mode, signaling data is input through the TSIG pin. This signaling PCM stream is buffered and inserted to the data stream being input at the TSERI pin.

Signaling data can be inserted on a per-channel basis by the transmit hardware-signaling channel-select (THSCS) function. The user has the ability to control which channels are to have signaling data from the TSIG pin inserted into them on a per-channel basis. See Section [10.2](#) for details on using this per-channel (THSCS) feature. The signaling insertion capabilities of the framer are available whether the transmit-side elastic store is enabled or disabled. If the elastic store is enabled, the backplane clock (TSYSCLK) can be either 1.544MHz or 2.048MHz. Also, if the elastic is enabled in conjunction with transmit hardware signaling, CCR3.7 must be set = 0.

10.10 Per-Channel Idle Code Generation

Channel data can be replaced by an idle code on a per-channel basis in the transmit and receive directions. When operated in the T1 mode, only the first 24 channels are used by the device, the remaining channels, CH25–CH32, are not used.

The device contains a 64-byte idle code array accessed by the idle array address register (TR.IAAR) and the per-channel idle code register (TR.PCICR). The contents of the array contain the idle codes to be substituted into the appropriate transmit or receive channels. This substitution can be enabled and disabled on a per-channel basis by the transmit-channel idle code-enable registers (TR.TCICE1–4) and receive-channel idle code-enable registers (TR.RCICE1–4).

To program idle codes, first select a channel by writing to the TR.IAAR register. Then write the idle code to the TR.PCICR register. For successive writes there is no need to load the TR.IAAR with the next consecutive address. The TR.IAAR register automatically increments after a write to the TR.PCICR register. The auto increment feature can be used for read operations as well. Bits 6 and 7 of the TR.IAAR register can be used to block write a common idle code to all transmit or receive positions in the array with a single write to the TR.PCICR register. Bits 6 and 7 of the TR.IAAR register should not be used for read operations. TR.TCICE1–4 and TR.RCICE1–4 are used to enable idle code replacement on a per-channel basis.

Table 10-10. Idle-Code Array Address Mapping

BITS 0 to 5 OF IAAR REGISTER	MAPS TO CHANNEL
0	Transmit Channel 1
1	Transmit Channel 2
2	Transmit Channel 3
—	—
—	—
30	Transmit Channel 31
31	Transmit Channel 32
32	Receive Channel 1
33	Receive Channel 2
34	Receive Channel 3
—	—
—	—
62	Receive Channel 31
63	Receive Channel 32

10.10.1 Idle-Code Programming Examples

Example 1

Sets transmit channel 3 idle code to 7Eh.

```
Write TR.IAAR = 02h ;select channel 3 in the array
Write TR.PCICR = 7Eh ;set idle code to 7Eh
```

Example 2

Sets transmit channels 3, 4, 5, and 6 idle code to 7Eh and enables transmission of idle codes for those channels.

```
Write TR.IAAR = 02h ;select channel 3 in the array
Write TR.PCICR = 7Eh ;set channel 3 idle code to 7Eh
Write TR.PCICR = 7Eh ;set channel 4 idle code to 7Eh
Write TR.PCICR = 7Eh ;set channel 5 idle code to 7Eh
Write TR.PCICR = 7Eh ;set channel 6 idle code to 7Eh
Write TR.TCICE1 = 3Ch ;enable transmission of idle codes for channels 3,4,5, and 6
```

Example 3

Sets transmit channels 3, 4, 5, and 6 idle code to 7Eh, EEh, FFh, and 7Eh, respectively.

```
Write TR.IAAR = 02h
Write TR.PCICR = 7Eh
Write TR.PCICR = EEh
Write TR.PCICR = FFh
Write TR.PCICR = 7Eh
```

Example 4

Sets all transmit idle codes to 7Eh.

```
Write TR.IAAR = 4xh
Write TR.PCICR = 7Eh
```

Example 5

Sets all receive and transmit idle codes to 7Eh and enables idle code substitution in all E1 transmit and receive channels.

```
Write TR.IAAR = Cxh ;enable block write to all transmit and receive positions in the array
Write TR.PCICR = 7Eh ;7Eh is idle code
Write TR.TCICE1 = FEh ;enable idle code substitution for transmit channels 2 through 8
;Although an idle code was programmed for channel 1 by the block write
;function above, enabling it for channel 1 would step on the frame
;alignment, alarms, and Sa bits
Write TR.TCICE2 = FFh ;enable idle code substitution for transmit channels 9 through 16
Write TR.TCICE3 = FEh ;enable idle code substitution for transmit channels 18 through 24
;Although an idle code was programmed for channel 17 by the block write
;function above, enabling it for channel 17 would step on the CAS frame
;alignment, and signaling information
Write TR.TCICE4 = FFh ;enable idle code substitution for transmit channels 25 through 32
Write TR.RCICE1 = FEh ;enable idle code substitution for receive channels 2 through 8
Write TR.RCICE2 = FFh ;enable idle code substitution for receive channels 9 through 16
Write TR.RCICE3 = FEh ;enable idle code substitution for receive channels 18 through 24
Write TR.RCICE4 = FFh ;enable idle code substitution for receive channels 25 through 32
```

The transmit-channel idle-code enable registers (TR.TCICE1/2/3/4) are used to determine which of the 24 T1 or 32 E1 channels from the backplane to the T1 or E1 line should be overwritten with the code placed in the per-channel code array.

The receive-channel idle-code enable registers (TR.RCICE1/2/3/4) are used to determine which of the 24 T1 or 32 E1 channels from the backplane to the T1 or E1 line should be overwritten with the code placed in the per-channel code array.

10.11 Channel Blocking Registers

The receive channel blocking registers (TR.RCBR1/TR.RCBR2/TR.RCBR3/TR.RCBR4) and the transmit channel blocking registers (TR.TCBR1/TR.TCBR2/TR.TCBR3/TR.TCBR4) control RCHBLK and TCHBLK pins, respectively. The RCHBLK and TCHBLK pins are user-programmable outputs that can be forced either high or low during individual channels. These outputs can be used to block clocks to a USART or LAPD controller in ISDN-PRI applications. When the appropriate bits are set to a 1, the RCHBLK and TCHBLK pins are held high during the entire corresponding channel time. Channels 25 through 32 are ignored when the device is operated in the T1 mode.

10.12 Elastic Stores Operation

The device contains dual two-frame elastic stores, one for the receive direction and one for the transmit direction. Both elastic stores are fully independent. The transmit and receive-side elastic stores can be enabled/disabled independently of each other. Also, each elastic store can interface to either a 1.544MHz or 2.048MHz/4.096MHz/8.192MHz/16.384MHz backplane without regard to the backplane rate the other elastic store is interfacing to.

The elastic stores have two main purposes. Firstly, they can be used for rate conversion. When the device is in the T1 mode, the elastic stores can rate-convert the T1 data stream to a 2.048MHz backplane. In E1 mode, the elastic store can rate-convert the E1 data stream to a 1.544MHz backplane. Secondly, they can be used to absorb the differences in frequency and phase between the T1 or E1 data stream and an asynchronous (i.e., not locked) backplane clock, which can be 1.544MHz or 2.048MHz. In this mode, the elastic stores manage the rate difference and perform controlled slips, deleting or repeating frames of data in order to manage the difference between the network and the backplane. The elastic stores can also be used to multiplex T1 or E1 data streams into higher backplane rates.

10.12.1 Receive Elastic Store

See the TR.IOCR1 and TR.IOCR2 registers for information about clock and I/O configurations. If the receive-side elastic store is enabled, then the user must provide either a 1.544MHz or 2.048MHz clock at the RSYCLK pin. The user has the option of either providing a frame/multiframe sync at the RSYNC pin or having the RSYNC pin provide a pulse on frame/multiframe boundaries. If signaling reinsertion is enabled, signaling data in TS16 is realigned to the multiframe sync input on RSYNC. Otherwise, a multiframe sync input on RSYNC is treated as a simple frame boundary by the elastic store. The framer always indicates frame boundaries on the network side of the elastic store by the RFSYNC output, whether the elastic store is enabled or not. Multiframe boundaries are always indicated by the RMSYNC output. If the elastic store is enabled, then RMSYNC outputs the multiframe boundary on the backplane side of the elastic store.

10.12.1.1 T1 Mode

If the user selects to apply a 2.048MHz clock to the RSYCLK pin, then the data output at RSERO is forced to all 1s every fourth channel and the F-bit is passed into the MSB of TS0. Hence, channels 1 (bits 1–7), 5, 9, 13, 17, 21, 25, and 29 [time slots 0 (bits 1–7), 4, 8, 12, 16, 20, 24, and 28] are forced to a 1. Also, in 2.048MHz applications, the RCHBLK output is forced high during the same channels as the RSERO pin. This is useful in T1-to-E1 conversion applications. If the two-frame elastic buffer either fills or empties, a controlled slip occurs. If the buffer empties, then a full frame of data is repeated at RSERO, and the TR.SR5.0 and TR.SR5.1 bits are set to a 1. If the buffer fills, then a full frame of data is deleted, and the TR.SR5.0 and TR.SR5.2 bits are set to a 1.

10.12.1.2 E1 Mode

If the elastic store is enabled, then either CAS or CRC4 multiframe boundaries are indicated through the RMSYNC output. If the user selects to apply a 1.544MHz clock to the RSYCLK pin, then every fourth channel of the received E1 data is deleted and an F-bit position, which is forced to 1, is inserted. Hence, channels 1, 5, 9, 13, 17, 21, 25, and 29 (time slots 0, 4, 8, 12, 16, 20, 24, and 28) are deleted from the received E1 data stream. Also, in 1.544MHz applications, the RCHBLK output is not active in channels 25 through 32 (i.e., RCBR4 is not active). If the two-frame elastic buffer either fills or empties, a controlled slip occurs. If the buffer empties, then a full frame of data is repeated at RSERO, and the TR.SR5.0 and TR.SR5.1 bits are set to a 1. If the buffer fills, then a full frame of data is deleted, and the TR.SR5.0 and TR.SR5.2 bits are set to a 1.

10.12.2 Transmit Elastic Store

See the TR.IOCR1 and TR.IOCR2 registers for information about clock and I/O configurations. The operation of the transmit elastic store is very similar to the receive side. If the transmit-side elastic store is enabled, a 1.544MHz or 2.048MHz clock can be applied to the TSYCLK input. Controlled slips in the transmit elastic store are reported in the TR.SR5.3 bit, and the direction of the slip is reported in the TR.SR5.4 and TR.SR5.5 bits. If hardware signaling insertion is not enabled, TR.CCR3.7 should be set = 1.

10.12.2.1 T1 Mode

If the user selects to apply a 2.048MHz clock to the TSYCLK pin, then the data input at TSERI is ignored every fourth channel. Therefore channels 1, 5, 9, 13, 17, 21, 25, and 29 (time slots 0, 4, 8, 12, 16, 20, 24, and 28) are ignored. The user can supply frame or multiframe sync pulse to the TSSYNC input. Also, in 2.048MHz applications, the TCHBLK output is forced high during the channels ignored by the framer.

10.12.2.2 E1 Mode

A 1.544MHz or 2.048MHz clock can be applied to the TSYCLK input. The user must supply a frame sync pulse or a multiframe sync pulse to the TSSYNC input.

10.12.3 Elastic Stores Initialization

There are two elastic store initializations that can be used to improve performance in certain applications, elastic store reset and elastic store align. Both of these involve the manipulation of the elastic store's read and write pointers and are useful primarily in synchronous applications (RSYSCLK/TSYCLK are locked to RCLKO/TCLKT, respectively) ([Table 10-11](#)).

Table 10-11. Elastic Store Delay After Initialization

INITIALIZATION	REGISTER BIT	DELAY
Receive Elastic Store Reset	TR.ESCR.2	8 Clocks < Delay < 1 Frame
Transmit Elastic Store Reset	TR.ESCR.6	1 Frame < Delay < 2 Frames
Receive Elastic Store Align	TR.ESCR.3	½ Frame < Delay < 1 ½ Frames
Transmit Elastic Store Align	TR.ESCR.7	½ Frame < Delay < 1 ½ Frames

10.12.4 Minimum Delay Mode

Elastic store minimum delay mode can be used when the elastic store's system clock is locked to its network clock (i.e., RCLKO locked to RSYSCLK for the receive side and TCLKT locked to TSYCLK for the transmit side). TR.ESCR.5 and TR.ESCR.1 enable the transmit and receive elastic store minimum delay modes. When enabled, the elastic stores are forced to a maximum depth of 32 bits instead of the normal two-frame depth. This feature is useful primarily in applications that interface to a 2.048MHz bus. Certain restrictions apply when minimum delay mode is used. In addition to the restriction mentioned above, RSYNC must be configured as an output when the receive elastic store is in minimum delay mode; TSYNC must be configured as an output when transmit minimum delay mode is enabled. In a typical application, RSYSCLK and TSYCLK are locked to RCLKO, and RSYNC (frame output mode) is connected to TSSYNC (frame input mode). All of the slip contention logic in the framer is disabled (since slips cannot occur). On power-up, after the RSYSCLK and TSYCLK signals have locked to their respective network clock signals, the elastic store reset bits (TR.ESCR.2 and TR.ESCR.6) should be toggled from a 0 to a 1 to ensure proper operation.

10.13 G.706 Intermediate CRC-4 Updating (E1 Mode Only)

The device can implement the G.706 CRC-4 recalculation at intermediate path points. When this mode is enabled, the data stream presented at TSER1 already has the FAS/NFAS, CRC multiframe alignment word, and CRC-4 checksum in time slot 0. The user can modify the Sa bit positions. This change in data content is used to modify the CRC-4 checksum. This modification, however, does not corrupt any error information the original CRC-4 checksum may contain. In this mode of operation, TSYNC must be configured to multiframe mode. The data at TSER1 must be aligned to the TSYNC signal. If TSYNC is an input, then the user must assert TSYNC aligned at the beginning of the multiframe relative to TSER1. If TSYNC is an output, the user must multiframe-align the data presented to TSER1.

Figure 10-4. CRC-4 Recalculate Method

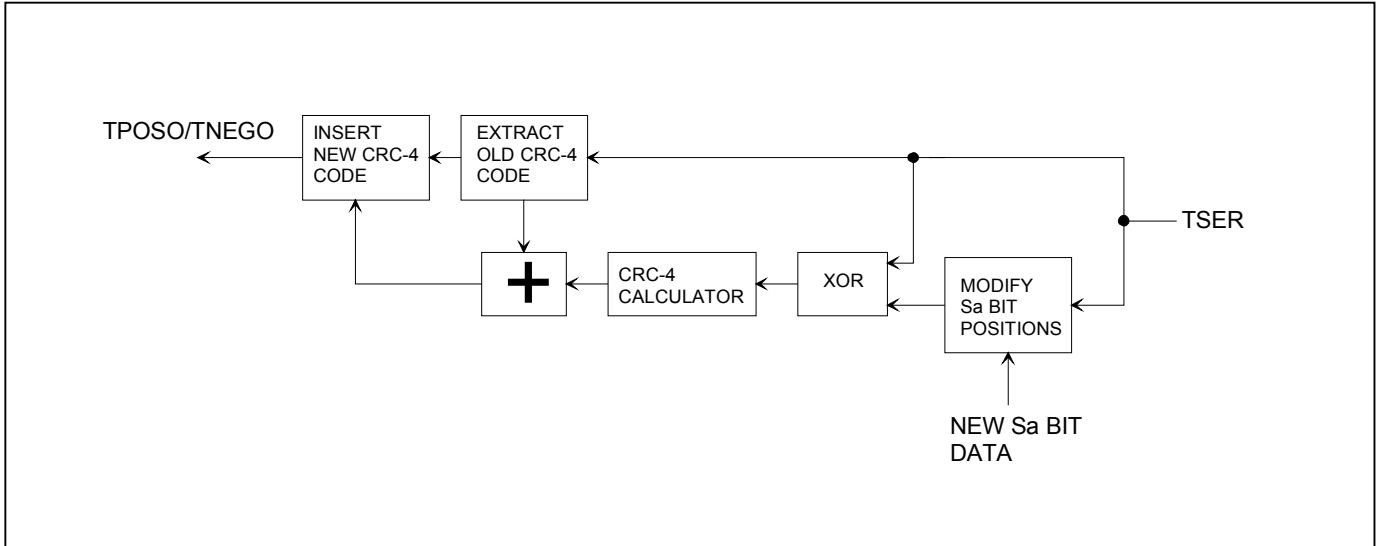

10.14 T1 Bit-Oriented Code (BOC) Controller

The transceiver contains a BOC generator on the transmit side and a BOC detector on the receive side. The BOC function is available only in T1 mode.

10.14.1 Transmit BOC

Bits 0 to 5 in the TR.TFDL register contain the BOC message to be transmitted. Setting TR.BOCC.0 = 1 causes the transmit BOC controller to immediately begin inserting the BOC sequence into the FDL bit position. The transmit BOC controller automatically provides the abort sequence. BOC messages are transmitted as long as TR.BOCC.0 is set.

10.14.1.1 Transmit a BOC

- 1) Write 6-bit code into the TR.TFDL register.
- 2) Set the SBOC bit in TR.BOCC = 1.

10.14.2 Receive BOC

The receive BOC function is enabled by setting TR.BOCC.4 = 1. The TR.RFDL register now operates as the receive BOC message and information register. The lower six bits of the TR.RFDL register (BOC message bits) are preset to all 1s. When the BOC bits change state, the BOC change-of-state indicator, TR.SR8.0, alerts the host. The host then reads the TR.RFDL register to get the BOC status and message. A change-of-state occurs when either a new BOC code has been present for a time determined by the receive BOC filter bits RBF0 and RBF1 in the TR.BOCC register, or a nonvalid code is being received.

10.14.2.1 Receive a BOC

- 1) Set integration time through TR.BOCC.1 and TR.BOCC.2.
- 2) Enable the receive BOC function (TR.BOCC.4 = 1).
- 3) Enable interrupt (TR.IMR8.0 = 1).
- 4) Wait for interrupt to occur.
- 5) Read the TR.RFDL register.
- 6) If TR.SR2.7 = 1, then a valid BOC message was received. The lower six bits of the TR.RFDL register comprise the message.

10.15 Additional (Sa) and International (Si) Bit Operation (E1 Only)

When operated in the E1 mode, the transceiver provides two methods for accessing the Sa and the Si bits. The first method involves using the internal TR.RAF/TR.RNAF and TR.TAF/TR.TNAF registers (Section [10.15.1](#)). The second method, which is covered in Section [10.15.2](#), involves an expanded version of the first method.

10.15.1 Method 1: Internal Register Scheme Based on Double-Frame

On the receive side, the TR.RAF and TR.RNAF registers always report the data as it received in the Sa and Si bit locations. The TR.RAF and TR.RNAF registers are updated on align-frame boundaries. The setting of the receive align frame bit in Status Register 4 (TR.SR4.0) indicates that the contents of the TR.RAF and TR.RNAF have been updated. The host can use the TR.SR4.0 bit to know when to read the TR.RAF and TR.RNAF registers. The host has 250µs to retrieve the data before it is lost.

On the transmit side, data is sampled from the TR.TAF and TR.TNAF registers with the setting of the transmit align frame bit in Status Register 4 (TR.SR4.3). The host can use the TR.SR4.3 bit to know when to update the TR.TAF and TR.TNAF registers. It has 250µs to update the data or else the old data is retransmitted. **If the TR.TAF and TR.TNAF registers are only being used to source the align frame and nonalign frame-sync patterns, then the host need only write once to these registers.** Data in the Si bit position is overwritten if either the framer is (1) programmed to source the Si bits from the TSER1 pin, (2) in the CRC4 mode, or (3) has automatic E-bit insertion enabled. Data in the Sa bit position is overwritten if any of the TR.E1TCR2.3 to TR.E1TCR2.7 bits are set to 1.

10.15.2 Method 2: Internal Register Scheme Based on CRC4 Multiframe

The receive side contains a set of eight registers (TR.RSiAF, TR.RSiNAF, TR.RRA, and TR.RSa4–TR.RSa8) that report the Si and Sa bits as they are received. These registers are updated with the setting of the receive CRC4 multiframe bit in Status Register 2 (TR.SR4.1). The host can use the TR.SR4.1 bit to know when to read these registers. The user has 2ms to retrieve the data before it is lost. The MSB of each register is the first received. See the following register descriptions for more details.

The transmit side also contains a set of eight registers (TR.TSiAF, TR.TSiNAF, TR.TRA, and TR.TSa4–TR.TSa8) that, through the transmit Sa bit control register (TR.TSACR), can be programmed to insert Si and Sa data. Data is sampled from these registers with the setting of the transmit multiframe bit in Status Register 2 (TR.SR4.4). The host can use the TR.SR4.4 bit to know when to update these registers. It has 2ms to update the data or else the old data is retransmitted. The MSB of each register is the first bit transmitted. See the register descriptions for more details.

10.16 Additional HDLC Controllers in T1/E1/J1 Transceiver

This device has two enhanced HDLC controllers, HDLC #1 and HDLC #2. Each controller is configurable for use with time slots, Sa4 to Sa8 bits (E1 mode), or the FDL (T1 mode). Each HDLC controller has 128-byte buffers in the transmit and receive paths. When used with time slots, the user can select any time slot or multiple time slots, contiguous or noncontiguous, as well as any specific bits within the time slot(s) to assign to the HDLC controllers.

The user must not map both transmit HDLC controllers to the same Sa bits, time slots or, in T1 mode, map both controllers to the FDL. HDLC #1 and HDLC #2 are identical in operation and therefore the following operational description refers only to a singular controller.

The HDLC controller performs the entire necessary overhead for generating and receiving performance report messages (PRMs) as described in ANSI T1.403 and the messages as described in AT&T TR54016. The HDLC controller automatically generates and detects flags, generates and checks the CRC check sum, generates and detects abort sequences, stuffs and destuffs zeros, and byte aligns to the data stream. The 128-byte buffers in the HDLC controller are large enough to allow a full PRM to be received or transmitted without host intervention.

The HDLC registers are divided into four groups: control/configuration, status/information, mapping, and FIFOs. [Table 10-12](#) lists these registers by group.

10.16.1 HDLC Configuration

The TR.HxTC and TR.HxRC registers perform the basic configuration of the HDLC controllers. Operating features such as CRC generation, zero stuffer, transmit and receive HDLC mapping options, and idle flags are selected here. These registers also reset the HDLC controllers.

Table 10-12. HDLC Controller Registers

REGISTER	FUNCTION
CONTROL AND CONFIGURATION	
TR.H1TC , HDLC #1 Transmit Control Register TR.H2TC , HDLC #2 Transmit Control Register	General control over the transmit HDLC controllers
TR.H1RC , HDLC #1 Receive Control Register TR.H2RC , HDLC #2 Receive Control Register	General control over the receive HDLC controllers
TR.H1FC , HDLC #1 FIFO Control Register TR.H2FC , HDLC #2 FIFO Control Register	Sets high watermark for receiver and low watermark for transmitter
STATUS AND INFORMATION	
TR.SR6 , HDLC #1 Status Register TR.SR7 , HDLC #2 Status Register	Key status information for both transmit and receive directions
TR.IMR6 , HDLC #1 Interrupt Mask Register TR.IMR7 , HDLC #2 Interrupt Mask Register	Selects which bits in the status registers (SR7 and SR8) cause interrupts
TR.INFO4 , HDLC #1 and #2 Information Register TR.INFO5 , HDLC #1 Information Register TR.INFO6 , HDLC #2 Information Register	Information about HDLC controller
TR.H1RPBA , HDLC #1 Receive Packet Bytes Available TR.H2RPBA , HDLC #2 Receive Packet Bytes Available	Indicates the number of bytes that can be read from the receive FIFO
TR.H1TFBA , HDLC #1 Transmit FIFO Buffer Available TR.H2TFBA , HDLC #2 Transmit FIFO Buffer Available	Indicates the number of bytes that can be written to the transmit FIFO
MAPPING	
TR.H1RCS1 , TR.H1RCS2 , TR.H1RCS3 , TR.H1RCS4 , HDLC #1 Receive Channel Select Registers TR.H2RCS1 , TR.H2RCS2 , TR.H2RCS3 , TR.H2RCS4 , HDLC #2 Receive Channel Select Registers	Selects which channels are mapped to the receive HDLC controller
TR.H1RTSBS , HDLC #1 Receive TS/Sa Bit Select TR.H2RTSBS , HDLC #2 Receive TS/Sa Bit Select	Selects which bits in a channel are used or which Sa bits are used by the receive HDLC controller
TR.H1TCS1 , TR.H1TCS2 , TR.H1TCS3 , TR.H1TCS4 , HDLC #1 Transmit Channel Select Registers TR.H2TCS1 , TR.H2TCS2 , TR.H2TCS3 , TR.H2TCS4 , HDLC #2 Transmit Channel Select Registers	Selects which channels are mapped to the transmit HDLC controller
TR.H1TTSBS , HDLC # 1 Transmit TS/Sa Bit Select TR.H2TTSBS , HDLC # 2 Transmit TS/Sa Bit Select	Selects which bits in a channel are used or which Sa bits are used by the transmit HDLC controller
FIFOs	
TR.H1RF , HDLC #1 Receive FIFO Register TR.H2RF , HDLC #1 Receive FIFO Register	Access to 128-byte receive FIFO
TR.H1TF , HDLC #1 Transmit FIFO Register TR.H2TF , HDLC #2 Transmit FIFO Register	Access to 128-byte transmit FIFO

10.16.2 FIFO Control

The FIFO control register (TR.HxFC) controls and sets the watermarks for the transmit and receive FIFOs. Bits 3, 4, and 5 set the transmit low watermark and the lower 3 bits set the receive high watermark.

When the transmit FIFO empties below the low watermark, the TLWM bit in the appropriate HDLC status register TR.SR6 or TR.SR7 is set. TLWM is a real-time bit and remains set as long as the transmit FIFO's read pointer is below the watermark. If enabled, this condition can also cause an interrupt through the $\overline{\text{INT}}$ pin.

When the receive FIFO fills above the high watermark, the RHWM bit in the appropriate HDLC status register is set. RHWM is a real-time bit and remains set as long as the receive FIFO's write pointer is above the watermark. If enabled, this condition can also cause an interrupt through the $\overline{\text{INT}}$ pin.

10.16.3 HDLC Mapping

The HDLC controllers must be assigned a space in the T1/E1 bandwidth in which they transmit and receive data. The controllers can be mapped to either the FDL (T1), Sa bits (E1), or to channels. If mapped to channels, then any channel or combination of channels, contiguous or not, can be assigned to an HDLC controller. When assigned to a channel(s), any combination of bits within the channel(s) can be avoided.

The TR.HxRCS1 – TR.HxRCS4 registers are used to assign the receive controllers to channels 1–24 (T1) or 1–32 (E1) according to the following table:

REGISTER	CHANNELS
TR.HxRCS1	1–8
TR.HxRCS2	9–16
TR.HxRCS3	17–24
TR.HxRCS4	25–32

The TR.HxTCS1 – TR.HxTCS4 registers are used to assign the transmit controllers to channels 1–24 (T1) or 1–32 (E1) according to the following table.

REGISTER	CHANNELS
TR.HxTCS1	1–8
TR.HxTCS2	9–16
TR.HxTCS3	17–24
TR.HxTCS4	25–32

10.16.4 FIFO Information

The transmit FIFO buffer-available register indicates the number of bytes that can be written into the transmit FIFO. The count from this register informs the host as to how many bytes can be written into the transmit FIFO without overflowing the buffer.

10.16.5 Receive Packet-Bytes Available

The lower 7 bits of the receive packet-bytes available register indicates the number of bytes (0 through 127) that can be read from the receive FIFO. The value indicated by this register (lower seven bits) informs the host as to how many bytes can be read from the receive FIFO without going past the end of a message. This value refers to one of four possibilities: the first part of a packet, the continuation of a packet, the last part of a packet, or a complete packet. After reading the number of bytes indicated by this register, the host then checks the HDLC information register for detailed message status.

If the value in the TR.HxRPBA register refers to the beginning portion of a message or continuation of a message, then the MSB of the TR.HxRPBA register returns a value of 1. This indicates that the host can safely read the number of bytes returned by the lower seven bits of the TR.HxRPBA register, but there is no need to check the information register since the packet has not yet terminated (successfully or otherwise).

10.16.5.1 Receive HDLC Code Example

The following is an example of a receive HDLC routine:

- 1) Reset receive HDLC controller.
- 2) Set HDLC mode, mapping, and high watermark.
- 3) Start new message buffer.
- 4) Enable RPE and RHWM interrupts.
- 5) Wait for interrupt.
- 6) Disable RPE and RHWM interrupts.
- 7) Read TR.HxRPBA register. N = TR.HxRPBA (lower 7 bits are byte count, MSB is status).
- 8) Read (N and 7Fh) bytes from receive FIFO and store in message buffer.
- 9) Read TR.INFO5 register.
- 10) If PS2, PS1, PS0 = 000, then go to Step 4.
- 11) If PS2, PS1, PS0 = 001, then packet terminated OK, save present message buffer.
- 12) If PS2, PS1, PS0 = 010, then packet terminated with CRC error.
- 13) If PS2, PS1, PS0 = 011, then packet aborted.
- 14) If PS2, PS1, PS0 = 100, then FIFO overflowed.
- 15) Go to Step 3.

10.17 Legacy FDL Support (T1 Mode)

10.17.1 Overview

To provide backward compatibility to the older DS21x52 T1 device, the transceiver maintains the circuitry that existed in the previous generation of the T1 framer. In new applications, it is recommended that the HDLC controllers and BOC controller described in Section [10.14](#) and [10.16](#) are used.

10.17.2 Receive Section

In the receive section, the recovered FDL bits or Fs bits are shifted bit-by-bit into the receive FDL register (TR.RFDL). Because the TR.RFDL is 8 bits in length, it fills up every 2ms (8 x 250µs). The framer signals an external microcontroller that the buffer has filled through the TR.SR8.3 bit. If enabled through TR.IMR8.3, the INT pin toggles low, indicating that the buffer has filled and needs to be read. The user has 2ms to read this data before it is lost. If the byte in the TR.RFDL matches either of the bytes programmed into the TR.RFDLM1 or TR.RFDLM2 registers, then the TR.SR8.1 bit is set to a 1 and the INT pin toggles low if enabled through TR.IMR8.1. This feature allows an external microcontroller to ignore the FDL or Fs pattern until an important event occurs.

The framer also contains a zero destuffer, which is controlled through the TR.T1RCR2.3 bit. In both ANSI T1.403 and TR54016, communications on the FDL follows a subset of an LAPD protocol. The LAPD protocol states that no more than five 1s should be transmitted in a row so that the data does not resemble an opening or closing flag (01111110) or an abort signal (11111111). If enabled through TR.T1RCR2.3, the device automatically looks for five 1s in a row, followed by a 0. If it finds such a pattern, it automatically removes the zero. If the zero destuffer sees six or more 1s in a row followed by a 0, the 0 is not removed. The TR.T1RCR2.3 bit should always be set to a 1 when the device is extracting the FDL. Refer to *Application Note 335: DS2141A, DS2151 Controlling the FDL* for information about using the device in FDL applications in this legacy support mode.

10.17.3 Transmit Section

The transmit section shifts out into the T1 data stream either the FDL (in the ESF framing mode) or the Fs bits (in the D4 framing mode) contained in the transmit FDL register (TR.TFDL). When a new value is written to TR.TFDL, it is multiplexed serially (LSB first) into the proper position in the outgoing T1 data stream. After the full 8 bits have been shifted out, the framer signals the host microcontroller by setting the TR.SR8.2 bit to a 1 that the buffer is empty and that more data is needed. The INT also toggles low if enabled through TR.IMR8.2. The user has 2ms to update TR.TFDL with a new value. If TR.TFDL is not updated, the old value in TR.TFDL is transmitted once again. The framer also contains a zero stuffer that is controlled through the TR.T1TCR2.5 bit. In both ANSI T1.403 and TR54016, communications on the FDL follows a subset of an LAPD protocol. The LAPD protocol states that no more than five 1s should be transmitted in a row so that the data does not resemble an opening or closing flag (01111110) or an abort signal (11111111). If enabled through TR.T1TCR2.5, the framer automatically looks for five 1s in a row. If it finds such a pattern, it automatically inserts a 0 after the five 1s. The TR.T1TCR2.5 bit should always be set to a 1 when the framer is inserting the FDL.

10.18 D4/SLC-96 Operation

In the D4 framing mode, the framer uses the TR.TFDL register to insert the Fs framing pattern. To allow the device to properly insert the Fs framing pattern, the TR.TFDL register at address C1h must be programmed to 1Ch and the following bits must be programmed as shown:

TR.T1TCR1.2 = 0 (source Fs data from the TR.TFDL register)

TR.T1TCR2.6 = 1 (allow the TR.TFDL register to load on multiframe boundaries)

Since the SLC-96 message fields share the Fs-bit position, the user can access these message fields through the TR.TFDL and TR.RFDL registers. Refer to *Application Note 345: DS2141A, DS2151, DS2152 SLC-96* for a detailed description about implementing an SLC-96 function.

10.19 Programmable In-Band Loop Code Generation and Detection

The transceiver has the ability to generate and detect a repeating bit pattern from one to eight bits or 16 bits in length. **This function is available only in T1 mode.** To transmit a pattern, the user loads the pattern into the transmit code-definition registers (TR.TCD1 and TR.TCD2) and selects the proper length of the pattern by setting the TC0 and TC1 bits in the in-band code control (TR.IBCC) register. When generating a 1-, 2-, 4-, 8-, or 16-bit pattern, both transmit code-definition registers must be filled with the proper code. Generation of a 3-, 5-, 6-, and 7-bit pattern only requires TR.TCD1 to be filled. Once this is accomplished, the pattern is transmitted as long as the TLOOP control bit (TR.T1CCR1.0) is enabled. Normally (unless the transmit formatter is programmed to not insert the F-bit position) the framer overwrites the repeating pattern once every 193 bits to send the F-bit position.

For example, to transmit the standard “loop-up” code for CSUs, which is a repeating pattern of ...10000100001... , set TR.TCD1 = 80h, TR.IBCC = 0, and TR.T1CCR1.0 = 1.

The framer has three programmable pattern detectors. Typically two of the detectors are used for “loop-up” and “loop-down” code detection. The user programs the codes to be detected in the receive up-code definition (TR.RUPCD1 and TR.RUPCD2) registers and the receive down-code definition (TR.RDNCD1 and TR.RDNCD2) registers, and the length of each pattern is selected through the TR.IBCC register. There is a third detector (spare) that is defined and controlled through the TR.RSCD1/ TR.RSCD2 and TR.RSCC registers. When detecting a 16-bit pattern, both receive code-definition registers are used together to form a 16-bit register. For 8-bit patterns, both receive code-definition registers are filled with the same value. Detection of a 1-, 2-, 3-, 4-, 5-, 6-, and 7-bit pattern only requires the first receive code-definition register to be filled. The framer detects repeating pattern codes in both framed and unframed circumstances with bit error rates as high as $10E-2$. The detectors are capable of handling both F-bit inserted and F-bit overwrite patterns. Writing the least significant byte of the receive code-definition register resets the integration period for that detector. The code detector has a nominal integration period of 36ms. Hence, after about 36ms of receiving a valid code, the proper status bit (LUP at TR.SR3.5, LDN at TR.SR3.6, and LSPARE at TR.SR3.7) is set to a 1. Normally codes are sent for a period of five seconds. It is recommended that the software poll the framer every 50ms to 1000ms until five seconds has elapsed to ensure the code is continuously present.

10.20 Line Interface Unit (LIU)

The LIU contains three sections: the receiver that handles clock and data recovery, the transmitter that waveshapes and drives the T1 line, and the jitter attenuator. These three sections are controlled by the line interface control registers (LIC1–LIC4), which are described in the following sections. The LIU has its own T1/E1 mode-select bit and can operate independently of the framer function.

The transceiver can switch between T1 or E1 networks without changing external components on the transmit or receive side. [Figure 10-7](#) shows a network connection using minimal components. In this configuration, the transceiver can connect to T1, J1, or E1 (75Ω or 120Ω) without component changes. The receiver can adjust the 120Ω termination to 100Ω or 75Ω. The transmitter can adjust its output impedance to provide high return-loss characteristics for 120Ω, 100Ω, and 75Ω lines. Other components can be added to this configuration to meet safety and network protection requirements (Section [10.24](#)).

10.20.1 LIU Operation

The analog AMI/HDB3 waveform off the E1 line or the AMI/B8ZS waveform off of the T1 line is transformer-coupled into the RTIP and RRING pins of the device. The user has the option to use internal termination, software selectable for 75Ω/100Ω/120Ω applications, or external termination. The LIU recovers clock and data from the analog signal and passes it through the jitter-attenuation mux outputting the received line clock at RDCLKO and bipolar or NRZ data at RPOSO and RNEGO. The transceiver contains an active filter that reconstructs the analog-received signal for the nonlinear losses that occur in transmission. The receive circuitry also is configurable for various monitor applications. The device has a usable receive sensitivity of 0dB to -43dB for E1 and 0dB to -36dB for T1, which allow the device to operate on 0.63mm (22AWG) cables up to 2.5km (E1) and 6k feet (T1) in length. Data input at TPOSI and TNEGI is sent through the jitter-attenuation mux to the waveshaping circuitry and line driver. The transceiver drives the E1 or T1 line from the TTIP and TRING pins through a coupling transformer. The line driver can handle both CEPT 30/ISDN-PRI lines for E1 and long-haul (CSU) or short-haul (DSX-1) lines for T1.

10.20.2 Receiver

The receiver contains a digital clock recovery system. The device couples to the receive E1 or T1 twisted pair (or coaxial cable in 75Ω E1 applications) through a 1:1 transformer. See [Table 10-13](#) for transformer details. The device has the option of using software-selectable termination requiring only a single fixed pair of termination resistors.

The transceiver's LIU is designed to be fully software selectable for E1 and T1, requiring no change to any external resistors for the receive side. The receive side allows the user to configure the transceiver for 75Ω, 100Ω, or 120Ω receive termination by setting the RT1 (TR.LIC4.1) and RT0 (TR.LIC4.0) bits. When using the internal termination feature, the resistors labeled R in [Figure 10-7](#) should be 60Ω each. If external termination is used, RT1 and RT0 should be set to 0 and the resistors labeled R in [Figure 10-7](#) should be 37.5Ω, 50Ω, or 60Ω each, depending on the line impedance.

There are two ranges of user-selectable receive sensitivity for T1 and E1. The EGL bit of TR.LIC1 (TR.LIC1.4) selects the full or limited sensitivity. The resultant E1 or T1 clock derived from MCLK is multiplied by 16 through an internal PLL and fed to the clock recovery system. The clock recovery system uses the clock from the PLL circuit to form a 16-times over-sampler that is used to recover the clock and data. This over-sampling technique offers outstanding performance to meet jitter tolerance specifications shown in [Figure 10-10](#).

Normally, the clock that is output at the RCLKO pin is the recovered clock from the E1 AMI/HDB3 or T1 AMI/B8ZS waveform presented at the RTIP and RRING inputs. If the jitter attenuator is placed in the receive path (as is the case in most applications), the jitter attenuator restores the RCLKO to an approximate 50% duty cycle. If the jitter attenuator is either placed in the transmit path or is disabled, the RCLKO output can exhibit slightly shorter high cycles of the clock. This is because of the highly over-sampled digital-clock recovery circuitry. See the *Receive AC Timing Characteristics* in Section [13.9](#) for more details. When no signal is present at RTIP and RRING, a receive carrier loss (RCL) condition occurs and the RCLKO is derived from the JACLK source.

10.20.2.1 Receive Level Indicator and Threshold Interrupt

The device reports the signal strength at RTIP and RRING in 2.5dB increments through RL3–RL0 located in Information Register 2 (TR.INFO2). This feature is helpful when trouble-shooting line-performance problems. The device can initiate an interrupt whenever the input falls below a certain level through the input-level under-threshold indicator (TR.SR1.7). Using the RLT0–RLT4 bits of the TR.CCR4 register, the user can set a threshold in 2.5dB increments. The TR.SR1.7 bit is set whenever the input level at RTIP and RRING falls below the threshold set by the value in RLT0–RLT4. The level must remain below the programmed threshold for approximately 50ms for this bit to be set. The accuracy of the receive level indication is ± 1 LSB (2.5dB) from 25°C to 85°C and ± 2 LSBs (5dB) from -40°C to 25°C.

10.20.2.2 Receive G.703 Synchronization Signal (E1 Mode)

The transceiver is capable of receiving a 2.048MHz square-wave synchronization clock as specified in Section 13 of ITU G.703, October 1998. In order to use the device in this mode, set the receive synchronization clock enable (TR.LIC3.2) = 1.

10.20.2.3 Monitor Mode

Monitor applications in both E1 and T1 require various flat gain settings for the receive-side circuitry. The device can be programmed to support these applications through the monitor mode control bits MM1 and MM0 in the TR.LIC3 register ([Figure 10-5](#)).

Figure 10-5. Typical Monitor Application

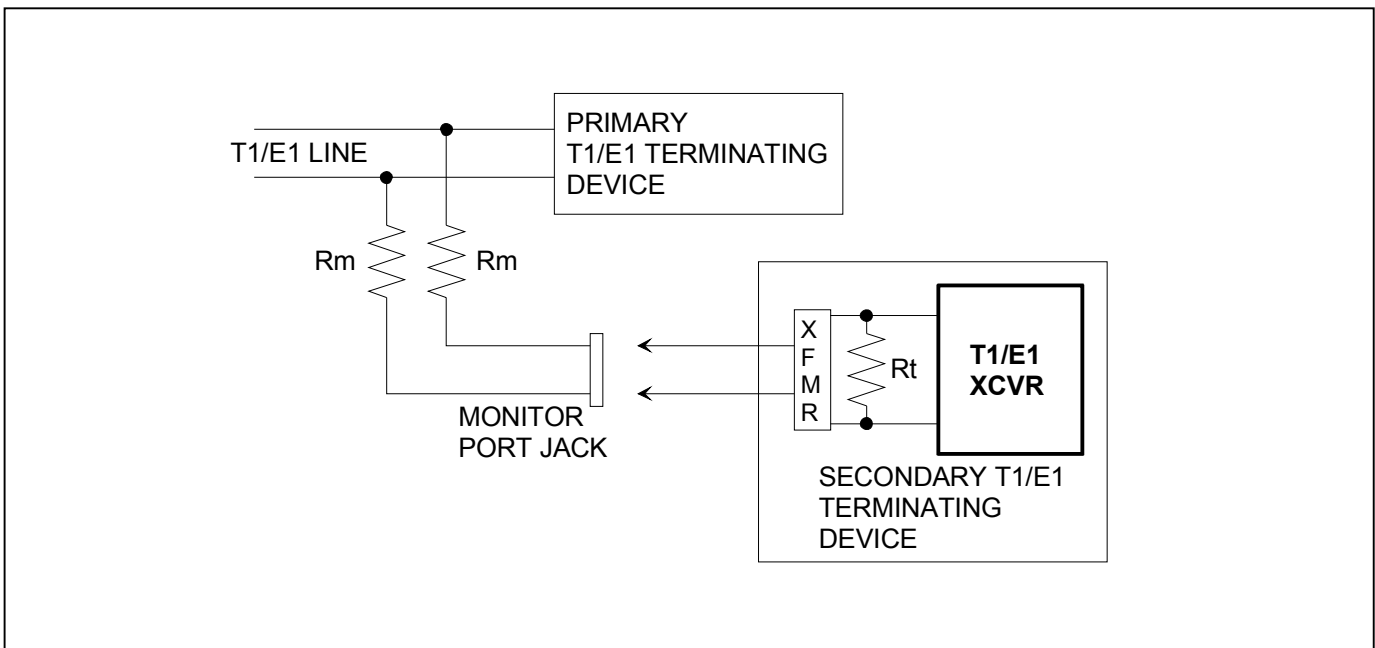

10.20.3 Transmitter

The transceiver uses a phase-lock loop along with a precision digital-to-analog converter (DAC) to create the waveforms that are transmitted onto the E1 or T1 line. The waveforms created by the device meet the latest ETSI, ITU-T, ANSI, and AT&T specifications. The user selects which waveform is generated by setting the ETS bit (TR.LIC2.7) for E1 or T1 operation, then programming the L2/L1/L0 bits in register TR.LIC1 for the appropriate application.

A 2.048MHz or 1.544MHz clock is required at TDCLKI for transmitting data presented at TPOSI and TNEGI. Normally these pins are connected to TCLKO, TPOSO, and TNEGO. However, the LIU can operate in an independent fashion. ITU specification G.703 requires an accuracy of ± 50 ppm for both T1 and E1. TR62411 and ANSI specifications require an accuracy of ± 32 ppm for T1 interfaces. The clock can be sourced internally from RCLKO or JACLK. See TR.LIC2.3, TR.LIC4.4, and TR.LIC4.5 for details. Because of the nature of the transmitter's design, very little jitter (less than $0.005U_{I_{P,P}}$ broadband from 10Hz to 100kHz) is added to the jitter present on TCLKT. Also, the waveforms created are independent of the duty cycle of TCLKT. The transmitter in the device couples to the E1 or T1 transmit twisted pair (or coaxial cable in some E1 applications) through a 1:2 step-up transformer. For the device to create the proper waveforms, the transformer used must meet the specifications listed in [Table 10-13](#). The device has the option of using software-selectable transmit termination.

The transmit line drive has two modes of operation: fixed gain or automatic gain. In the fixed gain mode, the transmitter outputs a fixed current into the network load to achieve a nominal pulse amplitude. In the automatic gain mode, the transmitter adjusts its output level to compensate for slight variances in the network load. See the *Transmit Line Build-Out Control* (TR.TLBC) register for details.

10.20.3.1 Transmit Short-Circuit Detector/Limiter

The device has an automatic short-circuit limiter that limits the source current to 50mA (RMS) into a 1 Ω load. This feature can be disabled by setting the SCLD bit (TR.LIC2.1) = 1. TCLE (TR.INFO2.5) provides a real-time indication of when the current limiter is activated. If the current limiter is disabled, TCLE indicates that a short-circuit condition exists. Status Register TR.SR1.2 provides a latched version of the information, which can be used to activate an interrupt when enabled by the TR.IMR1 register. The TPD bit (TR.LIC1.0) powers down the transmit line driver and three-states the TTIP and TRING pins.

10.20.3.2 Transmit Open-Circuit Detector

The device can also detect when the TTIP or TRING outputs are open circuited. TOCD (TR.INFO2.4) provides a real-time indication of when an open circuit is detected. TR.SR1 provides a latched version of the information (TR.SR1.1), which can be used to activate an interrupt when enabled by the TR.IMR1 register.

10.20.3.3 Transmit BPV Error Insertion

When IBPV (TR.LIC2.5) is transitioned from a 0 to a 1, the device waits for the next occurrence of three consecutive 1s to insert a BPV. IBPV must be cleared and set again for another BPV error insertion.

10.20.3.4 Transmit G.703 Synchronization Signal (E1 Mode)

The transceiver can transmit the 2.048MHz square-wave synchronization clock as specified in Section 13 of ITU G.703, October 1998. In order to transmit the 2.048MHz clock, when in E1 mode, set the transmit synchronization clock enable (TR.LIC3.1) = 1.

10.21 MCLK Prescaler

A 16.384MHz, 8.192MHz, 4.096MHz, 2.048MHz, or 1.544MHz clock must be applied at MCLK. ITU specification G.703 requires an accuracy of ± 50 ppm for both T1 and E1. TR62411 and ANSI specifications require an accuracy of ± 32 ppm for T1 interfaces. A prescaler divides the 16MHz, 8MHz, or 4MHz clock down to 2.048MHz. There is an on-board PLL for the jitter attenuator, which converts the 2.048MHz clock to a 1.544MHz rate for T1 applications. Setting JAMUX (TR.LIC2.3) to a logic 0 bypasses this PLL.

10.22 Jitter Attenuator

The device contains an on-board jitter attenuator that can be set to a depth of either 32 or 128 bits through the JABDS bit (TR.LIC1.2). The 128-bit mode is used in applications where large excursions of wander are expected. The 32-bit mode is used in delay-sensitive applications. The characteristics of the attenuation are shown in [Figure 10-12](#). The jitter attenuator can be placed in either the receive path or the transmit path by appropriately setting or clearing the JAS bit (TR.LIC1.3). Setting the DJA bit (TR.LIC1.1) disables (in effect, removes) the jitter attenuator. On-board circuitry adjusts either the recovered clock from the clock/data recovery block or the clock applied at the TCLKT pin to create a smooth jitter-free clock that is used to clock data out of the jitter attenuator FIFO. It is acceptable to provide a gapped/bursty clock at the TCLKT pin if the jitter attenuator is placed on the transmit side. If the incoming jitter exceeds either $120U_{I_{P,P}}$ (buffer depth is 128 bits) or $28U_{I_{P,P}}$ (buffer depth is 32 bits), then the transceiver divides the internal nominal 32.768MHz (E1) or 24.704MHz (T1) clock by either 15 or 17 instead of the normal 16 to keep the buffer from overflowing. When the device divides by either 15 or 17, it also sets the jitter attenuator limit trip (JALT) bit in Status Register 1 (TR.SR1.4).

10.23 CMI (Code Mark Inversion) Option

The device provides a CMI interface for connection to optical transports. This interface is a unipolar 1T2B signal type. Ones are encoded as either a logical 1 or 0 level for the full duration of the clock period. Zeros are encoded as a 0-to-1 transition at the middle of the clock period.

Figure 10-6. CMI Coding

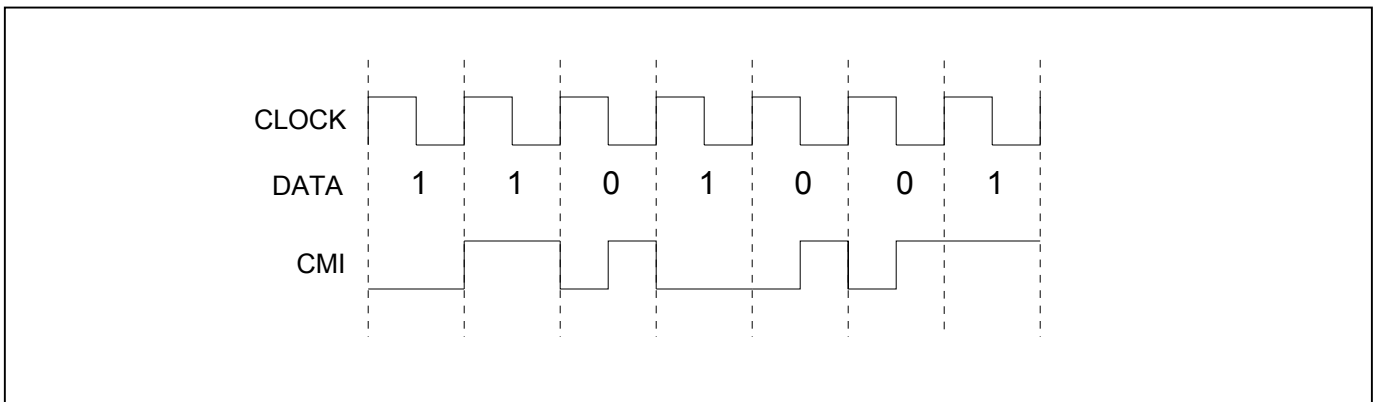

Transmit and receive CMI are enabled through TR.LIC4.7. When this register bit is set, the TTIP pin outputs CMI-coded data at normal levels. This signal can be used to directly drive an optical interface. When CMI is enabled, the user can also use HDB3/B8ZS coding. When this register bit is set, the RTIP pin becomes a unipolar CMI input. The CMI signal is processed to extract and align the clock with data.

10.24 Recommended Circuits

Figure 10-7. Basic Interface

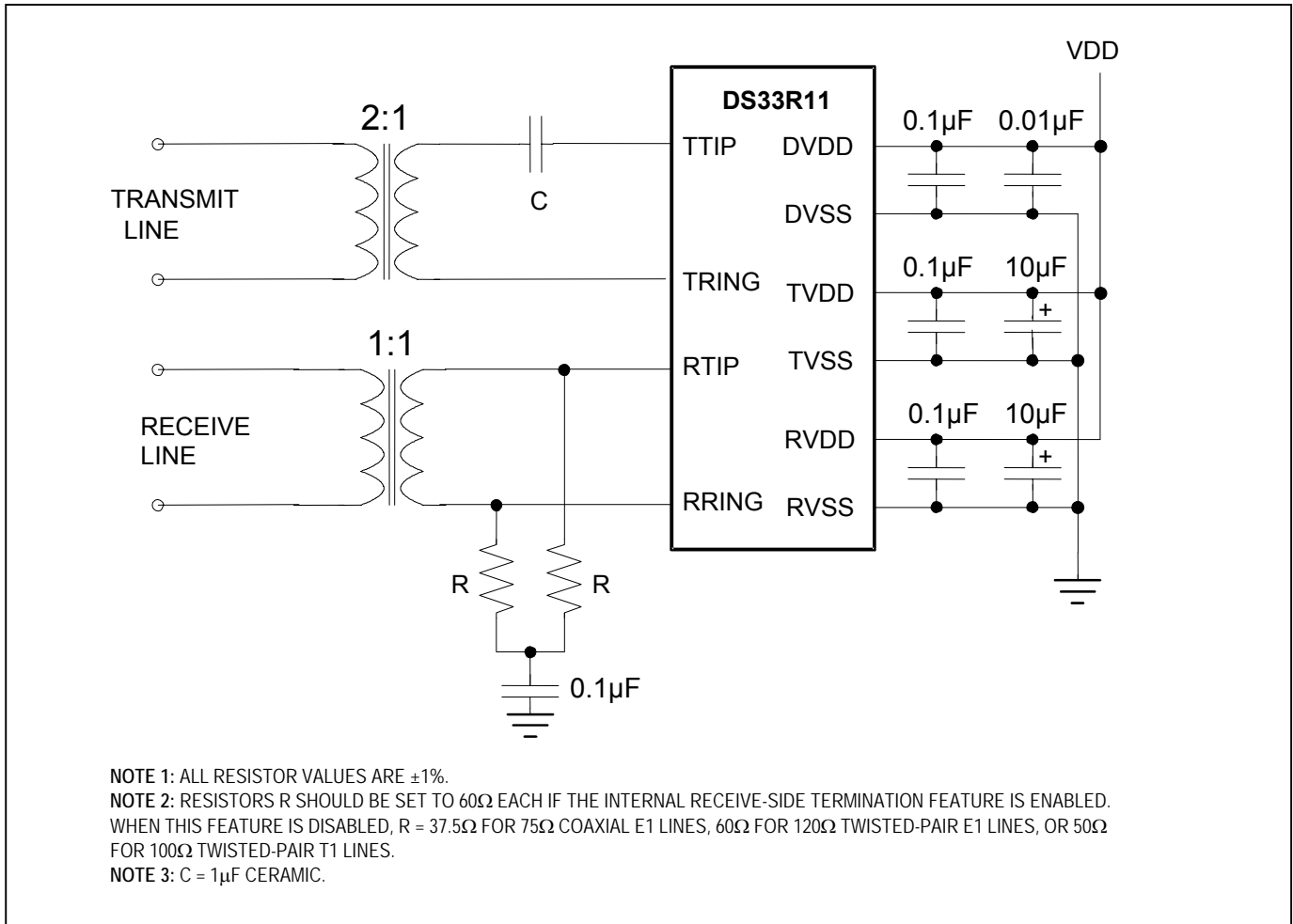

Refer to *Application Note 324: T1/E1 Network Interface Design* for more information on protected interfaces.

Table 10-13. Transformer Specifications

SPECIFICATION	RECOMMENDED VALUE
Turns Ratio 3.3V Applications	1:1 (receive) and 1:2 (transmit) $\pm 2\%$
Primary Inductance	$600\mu\text{H}$ (min)
Leakage Inductance	$1.0\mu\text{H}$ (max)
Intertwining Capacitance	40pF (max)
Transmit Transformer DC Resistance	
Primary (Device Side)	1.0Ω (max)
Secondary	2.0Ω (max)
Receive Transformer DC Resistance	
Primary (Device Side)	1.2Ω (max)
Secondary	1.2Ω (max)

Figure 10-8. E1 Transmit Pulse Template

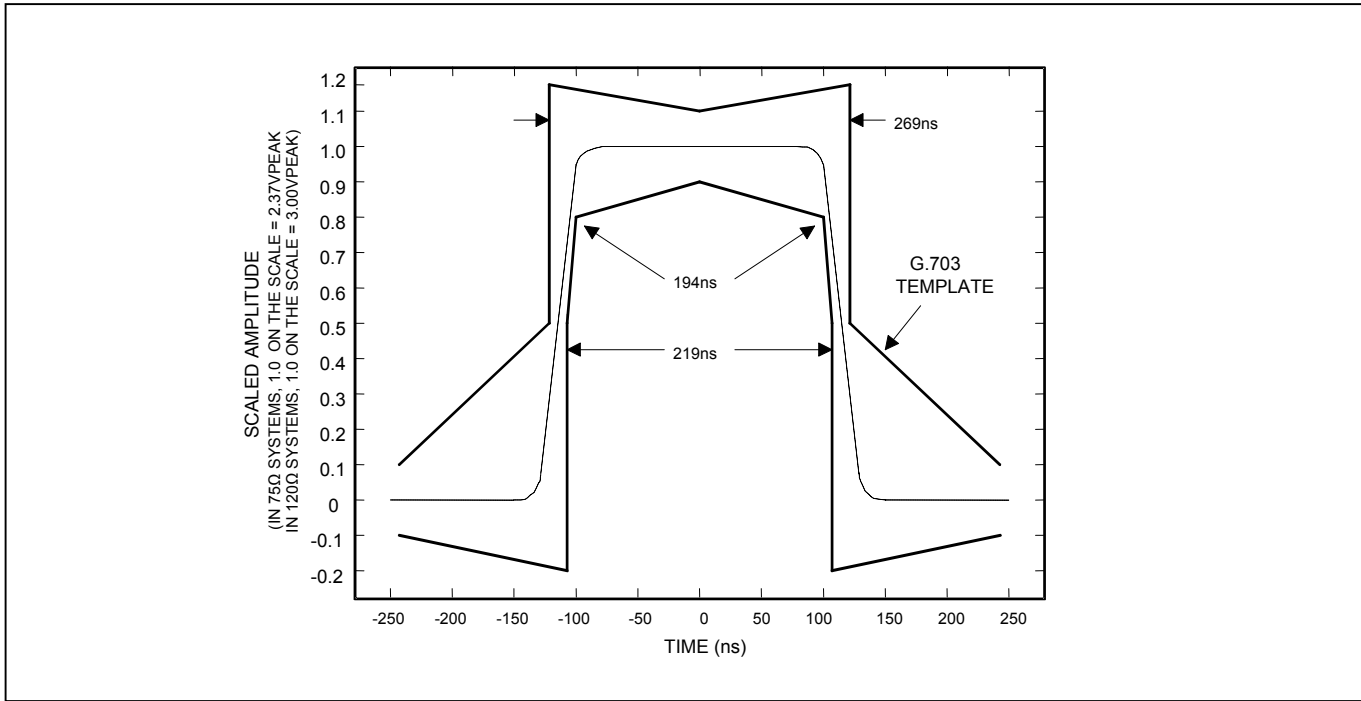

Figure 10-9. T1 Transmit Pulse Template

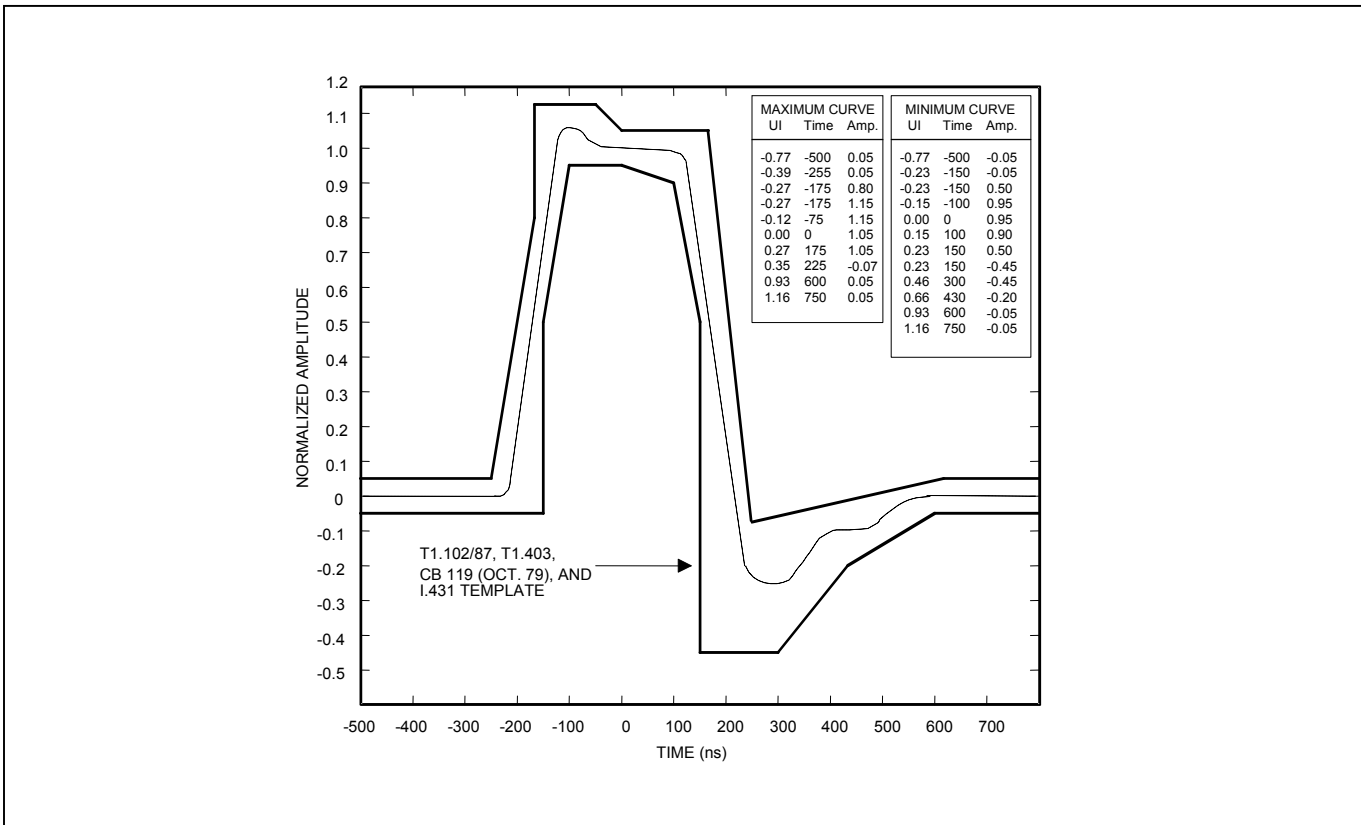

Figure 10-10. Jitter Tolerance

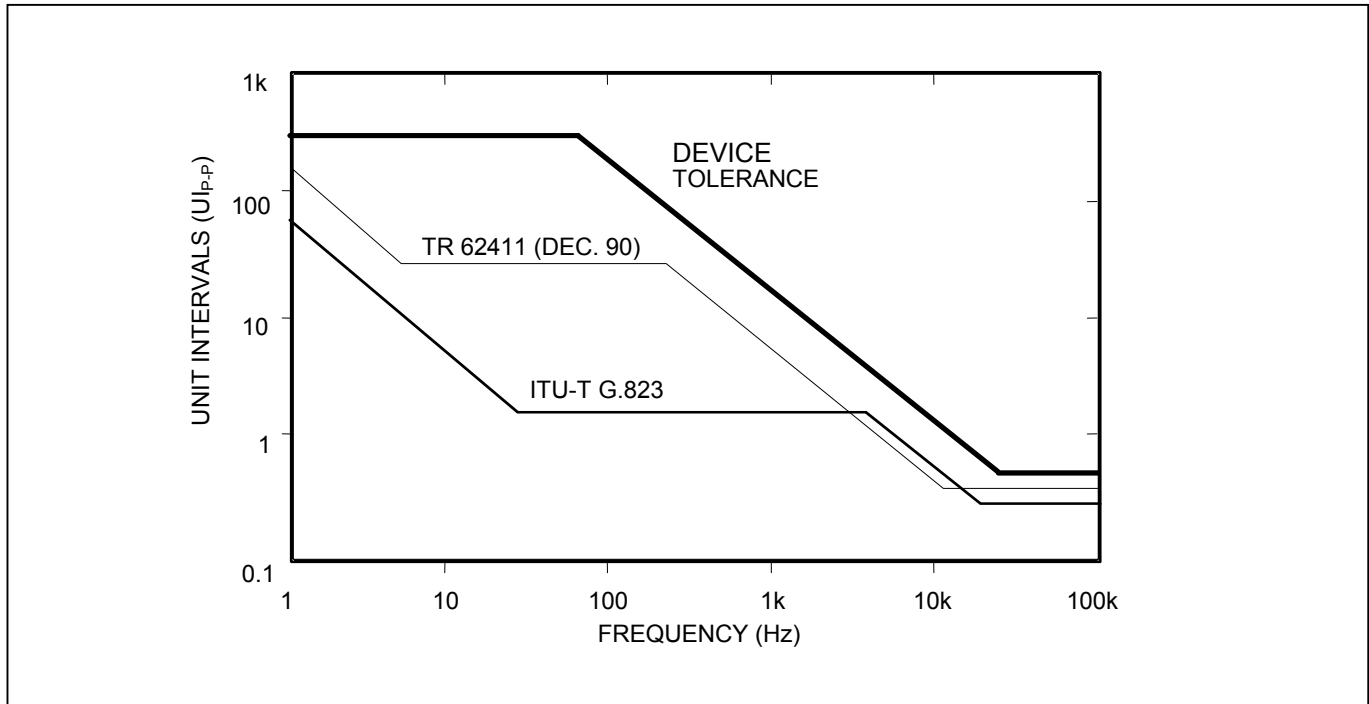

Figure 10-11. Jitter Tolerance (E1 Mode)

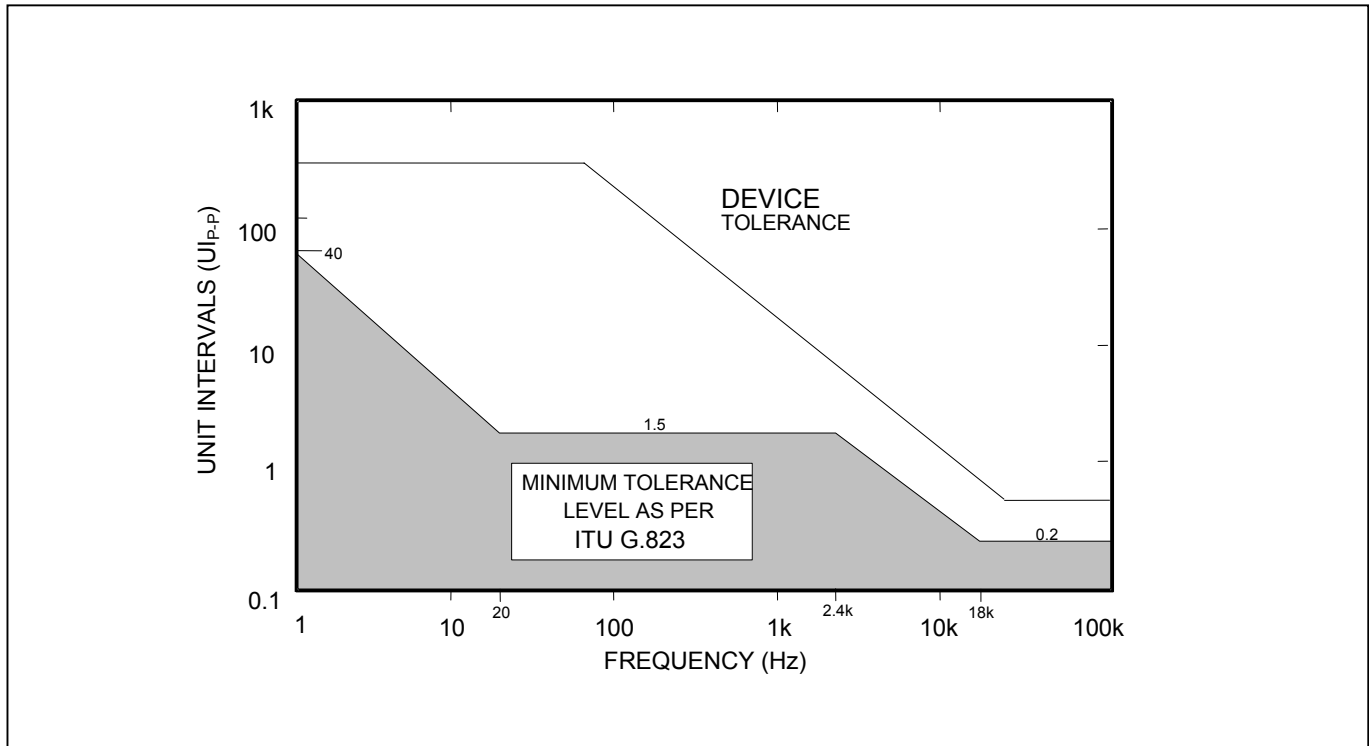

Figure 10-12. Jitter Attenuation (T1 Mode)

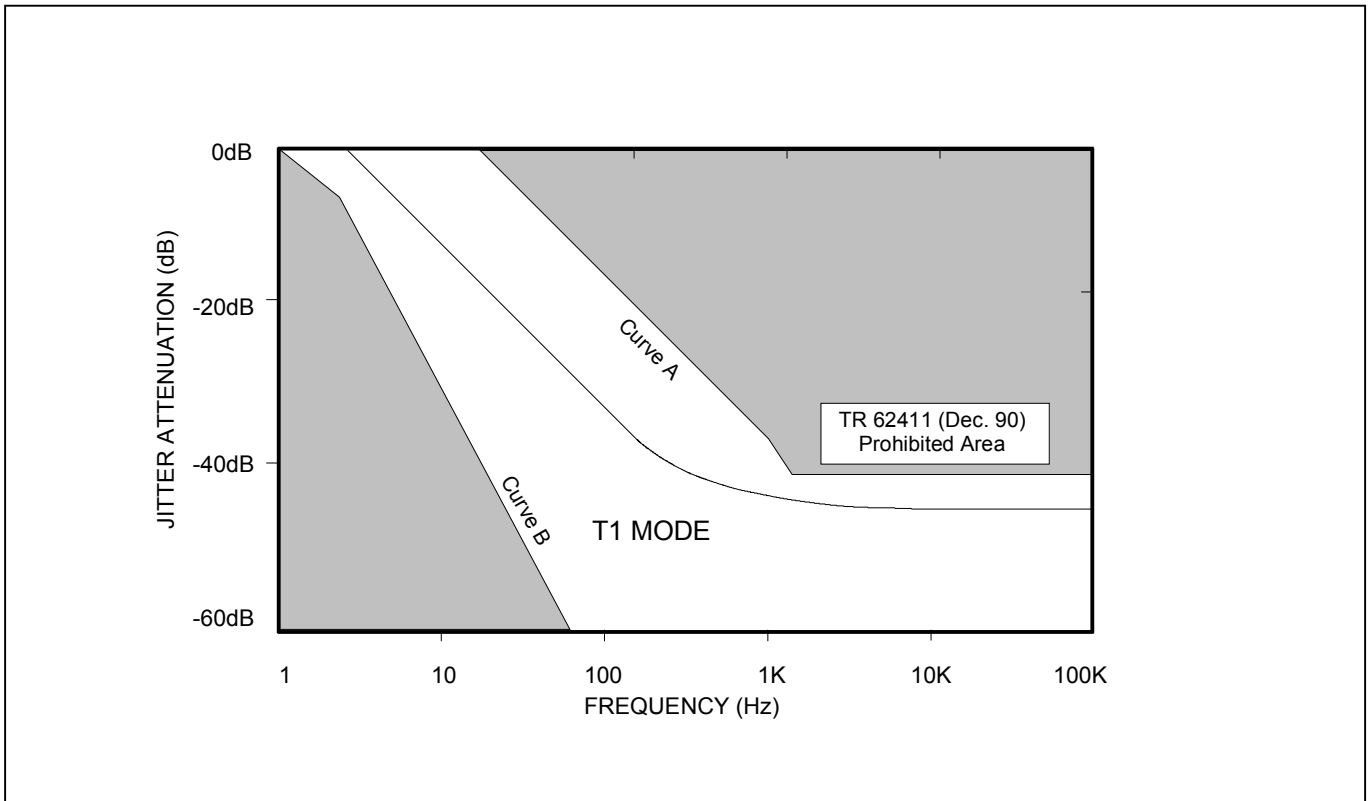

Figure 10-13. Jitter Attenuation (E1 Mode)

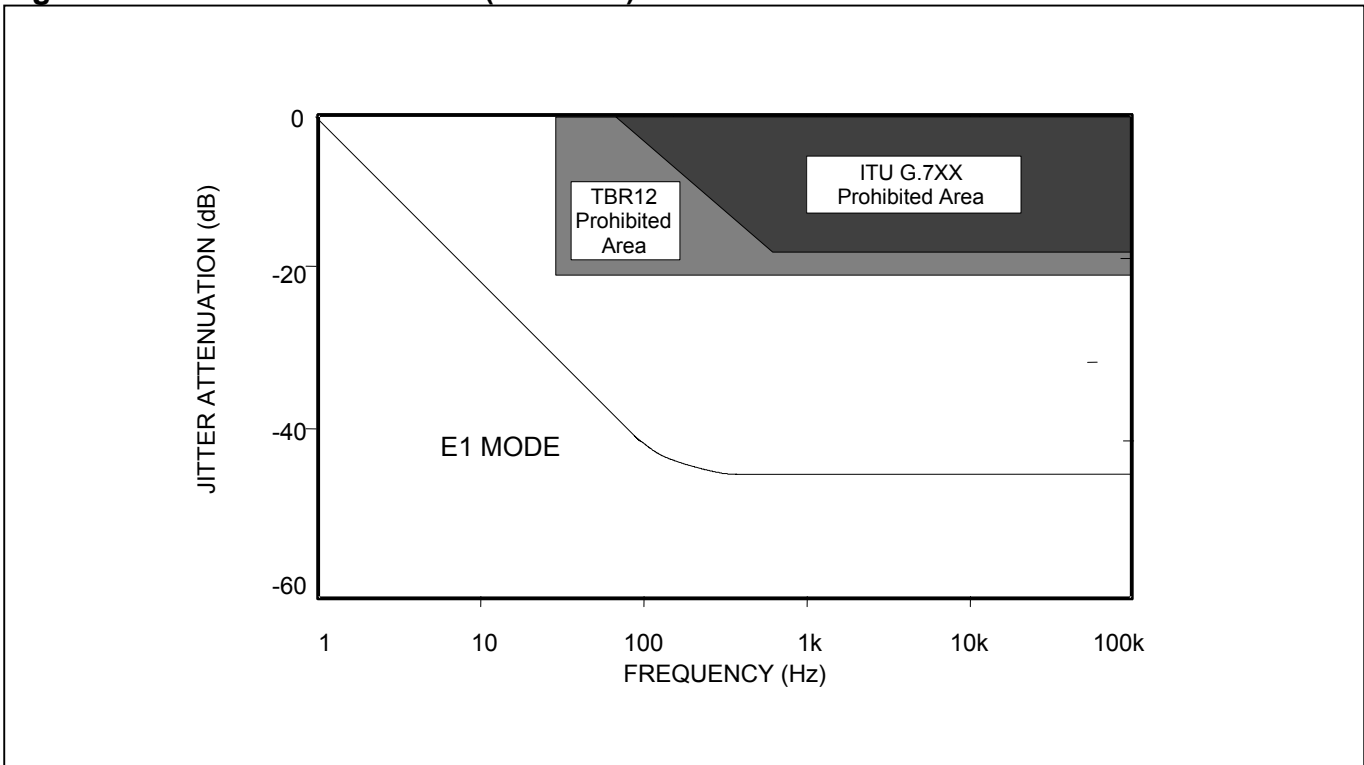
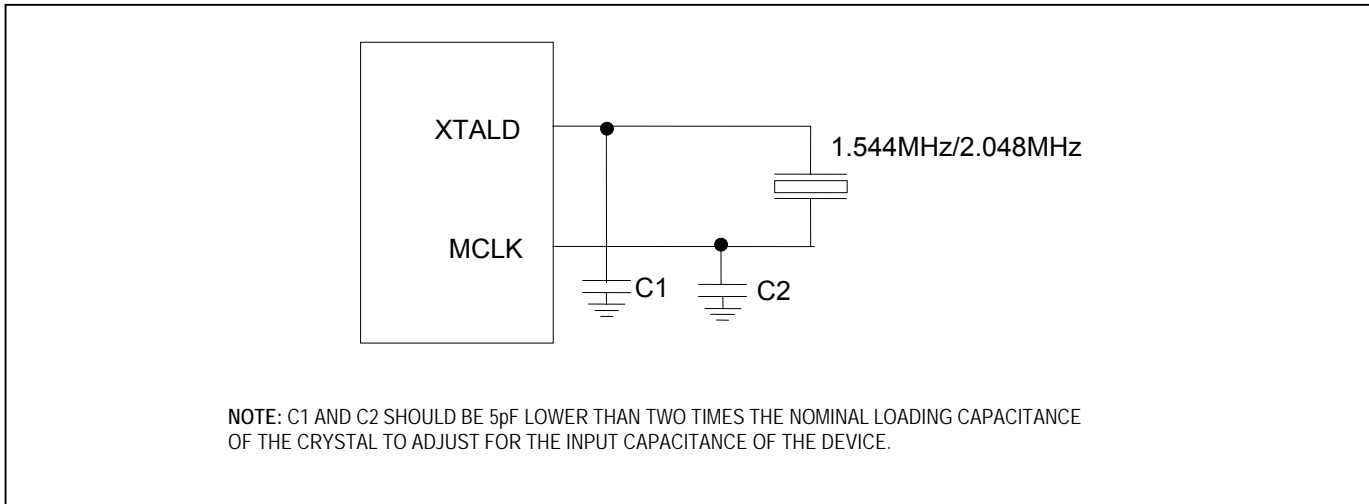

Figure 10-14. Optional Crystal Connections

10.25 T1/E1/J1 TRANSCEIVER BERT FUNCTION

The BERT block can generate and detect pseudorandom and repeating bit patterns. It is used to test and stress data communication links, and it is capable of generating and detecting the following patterns:

- The pseudorandom patterns 2E7, 2E11, 2E15, and QRSS
- A repetitive pattern from 1 to 32 bits in length
- Alternating (16-bit) words that flip every 1 to 256 words
- Daly pattern

The BERT receiver has a 32-bit bit counter and a 24-bit error counter. The BERT receiver reports three events: a change in receive synchronizer status, a bit error being detected, and if either the bit counter or the error counter overflows. Each of these events can be masked within the BERT function through the BERT control register 1 (TR.BC1). If the software detects that the BERT has reported an event, then the software must read the BERT information register (BIR) to determine which event(s) has occurred. To activate the BERT block, the host must configure the BERT mux through the TR.BIC register.

10.25.1 BERT Status

TR.SR9 contains the status information on the BERT function. The host can be alerted through this register when there is a BERT change-of-state. A major change-of-state is defined as either a change in the receive synchronization (i.e., the BERT has gone into or out of receive synchronization), a bit error has been detected, or an overflow has occurred in either the bit counter or the error counter. The host must read status register 9 (TR.SR9) to determine the change-of-state.

10.25.2 BERT Mapping

The BERT function can be assigned to the network direction or backplane direction through the direction control bit in the BIC register (TR.BIC.1). See [Figure 10-15](#) and [Figure 10-16](#). The BERT also can be assigned on a per-channel basis. The BERT transmit control selector (BTCS) and BERT receive control selector (BRCS) bits of the per-channel pointer register (TR.PCPR) are used to map the BERT function into time slots of the transmit and receive data streams. In T1 mode, the user can enable mapping into the F-bit position for the transmit and receive directions through the RFUS and TFUS bits in the BERT interface control (TR.BIC) register.

Figure 10-15. Simplified Diagram of BERT in Network Direction

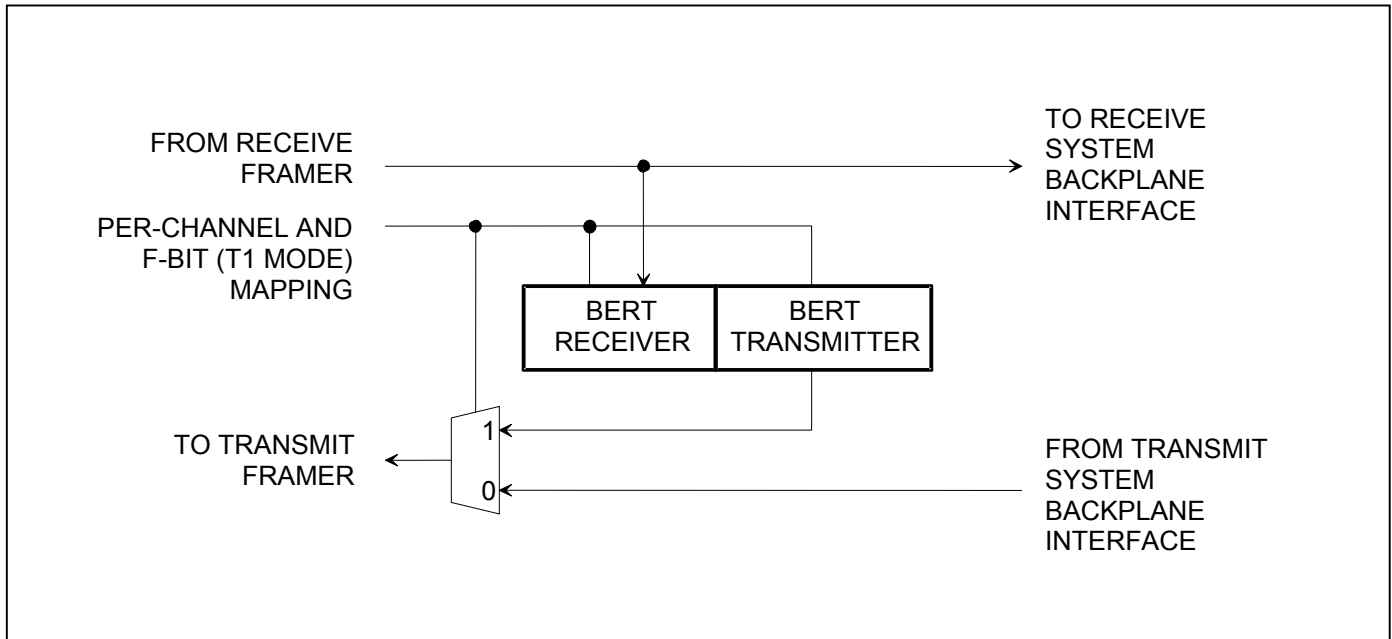
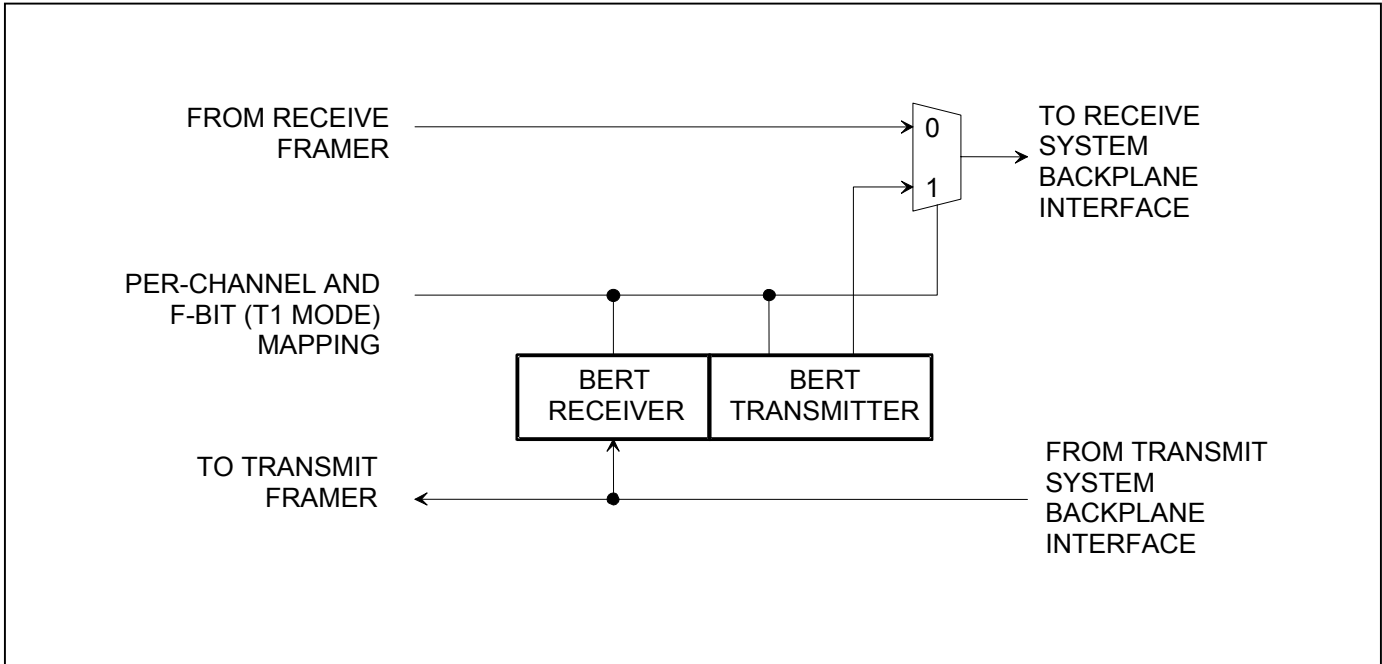

Figure 10-16. Simplified Diagram of BERT in Backplane Direction



10.25.3 BERT Repetitive Pattern Set

These registers must be properly loaded for the BERT to generate and synchronize to a repetitive pattern, a pseudorandom pattern, alternating word pattern, or a Daly pattern. For a repetitive pattern that is fewer than 32 bits, the pattern should be repeated so that all 32 bits are used to describe the pattern. For example, if the pattern was the repeating 5-bit pattern ...01101... (where the rightmost bit is the one sent first and received first), then TR.BRP1 should be loaded with ADh, TR.BRP2 with B5h, TR.BRP3 with D6h, and TR.BRP4 with 5Ah. For a pseudorandom pattern, all four registers should be loaded with all 1s (i.e., FFh). For an alternating word pattern, one word should be placed into TR.BRP1 and TR.BRP2 and the other word should be placed into TR.BRP3 and TR.BRP4. For example, if the DDS stress pattern "7E" is to be described, the user would place 00h in TR.BRP1, 00h in TR.BRP2, 7Eh in TR.BRP3, and 7Eh in TR.BRP4 and the alternating word counter would be set to 50 (decimal) to allow 100 bytes of 00h followed by 100 bytes of 7Eh to be sent and received.

10.25.4 BERT Bit Counter

The BERT Bit Counter is comprised of TR.BBC1, TR.BBC2, TR.BBC3, and TR.BBC4. Once BERT has achieved synchronization, this 32-bit counter increments for each data bit (i.e., clock) received. Toggling the LC control bit in TR.BC1 can clear this counter. This counter saturates when full and sets the BBCO status bit.

10.25.5 BERT Error Counter

The BERT Error Counter is comprised of TR.BEC1, TR.BEC2, and TR.BEC3. Once BERT has achieved synchronization, this 24-bit counter increments for each data bit received in error. Toggling the LC control bit in TR.BC1 can clear this counter. This counter saturates when full and sets the BECO status bit.

10.25.6 BERT Alternating Word-Count Rate

When the BERT is programmed in the alternating word mode, each word repeats for the count loaded into TR.BAWC. One word should be placed into TR.BRP1 and TR.BRP2 and the other word should be placed into TR.BRP3 and TR.BRP4.

10.26 Payload Error-Insertion Function (T1 Mode Only)

An error-insertion function is available in the transceiver and is used to create errors in the payload portion of the T1 frame in the transmit path. This function is only available in T1 mode. Errors can be inserted over the entire frame or the user can select which channels are to be corrupted. Errors are created by inverting the last bit in the count sequence. For example, if the error rate 1 in 16 is selected, the 16th bit is inverted. F-bits are excluded from the count and are never corrupted. Error rate changes occur on frame boundaries. Error-insertion options include continuous and absolute number with both options supporting selectable insertion rates.

Table 10-14. Transmit Error-Insertion Setup Sequence

STEP	ACTION
1	Enter desired error rate in the TR.ERC register. Note: If TR.ER3 through TR.ER0 = 0, no errors are generated even if the constant error-insertion feature is enabled.
2A or 2B	For constant error insertion, set CE = 1 (TR.ERC.4). For a defined number of errors: <ul style="list-style-type: none"> – Set CE = 0 (TR.ERC.4) – Load TR.NOE1 and TR.NOE2 with the number of errors to be inserted – Toggle WNOE (TR.ERC.7) from 0 to 1 to begin error insertion

10.26.1 Number-of-Errors Registers

The number-of-error registers determine how many errors are generated. Up to 1023 errors can be generated. The host loads the number of errors to be generated into the TR.NOE1 and TR.NOE2 registers. The host can also update the number of errors to be created by first loading the prescribed value into the TR.NOE registers and then toggling the WNOE bit in the error-rate control registers.

Table 10-15. Error Insertion Examples

VALUE	WRITE	READ
000h	Do not create any errors	No errors left to be inserted
001h	Create a single error	One error left to be inserted
002h	Create two errors	Two errors left to be inserted
3FFh	Create 1023 errors	1023 errors left to be inserted

10.27 Programmable Backplane Clock Synthesizer

The transceiver contains an on-chip clock synthesizer that generates a user-selectable clock output on the BPCLK pin, referenced to the recovered receive clock (RCLKO). The synthesizer uses a phase-locked loop to generate low-jitter clocks. Common applications include generation of port and backplane system clocks. The TR.CCR2 register is used to enable (TR.CCR2.0) and select (TR.CCR2.1 and TR.CCR2.2) the clock frequency of the BPCLK pin.

10.28 Fractional T1/E1 Support

The transceiver can be programmed to output gapped clocks for selected channels in the receive and transmit paths to simplify connections into a USART or LAPD controller in fractional T1/E1 or ISDN-PRI applications. The receive and transmit paths have independent enables. Channel formats supported include 56kbps and 64kbps. This is accomplished by assigning an alternate function to the RCHCLK and TCHCLK pins. Setting TR.CCR3.0 = 1 causes the RCHCLK pin to output a gapped clock as defined by the receive fractional T1/E1 function of the TR.PCPR register. Setting TR.CCR3.2 = 1 causes the TCHCLK pin to output a gapped clock as defined by the transmit fractional T1/E1 function of the TR.PCPR register. TR.CCR3.1 and TR.CCR3.3 can be used to select between 64kbps and 56kbps operation. See Section [10.2](#) for details about programming the per-channel function. In T1 mode no clock is generated at the F-bit position.

When 56kbps mode is selected, the LSB clock in the channel is omitted. Only the seven most significant bits of the channel have clocks.

10.29 T1/E1/J1 Transmit Flow Diagrams

Figure 10-17. T1/J1 Transmit Flow Diagram

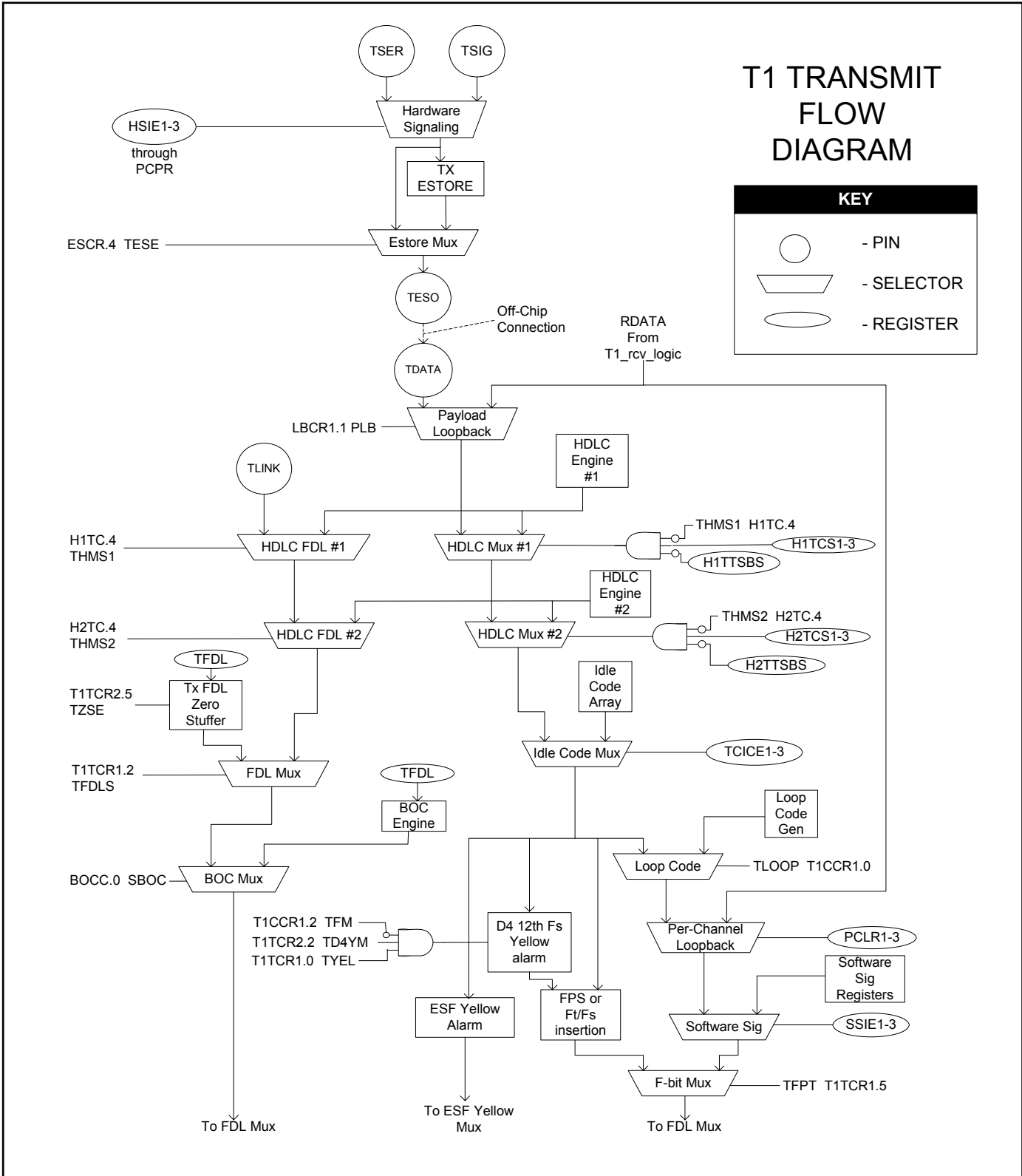

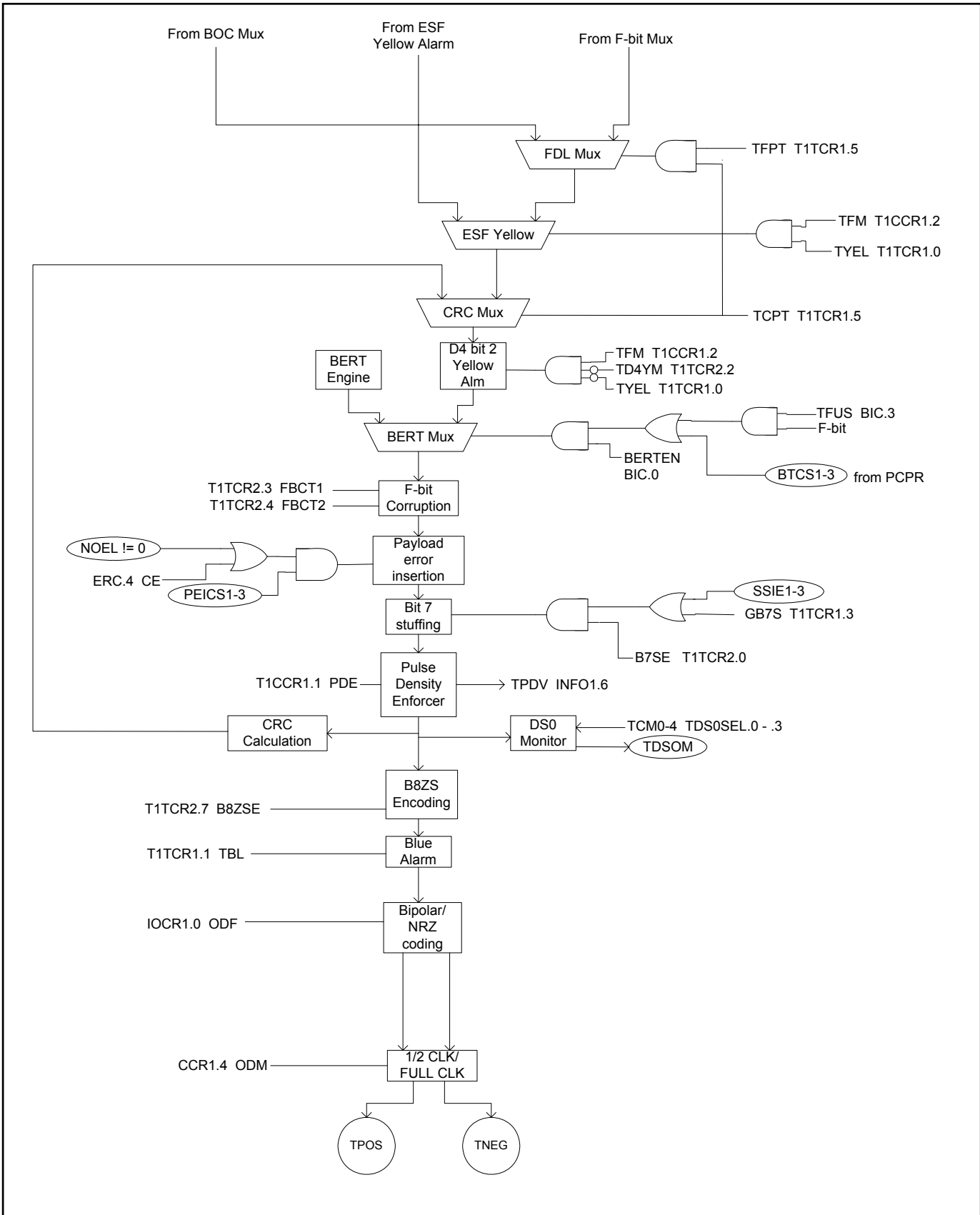
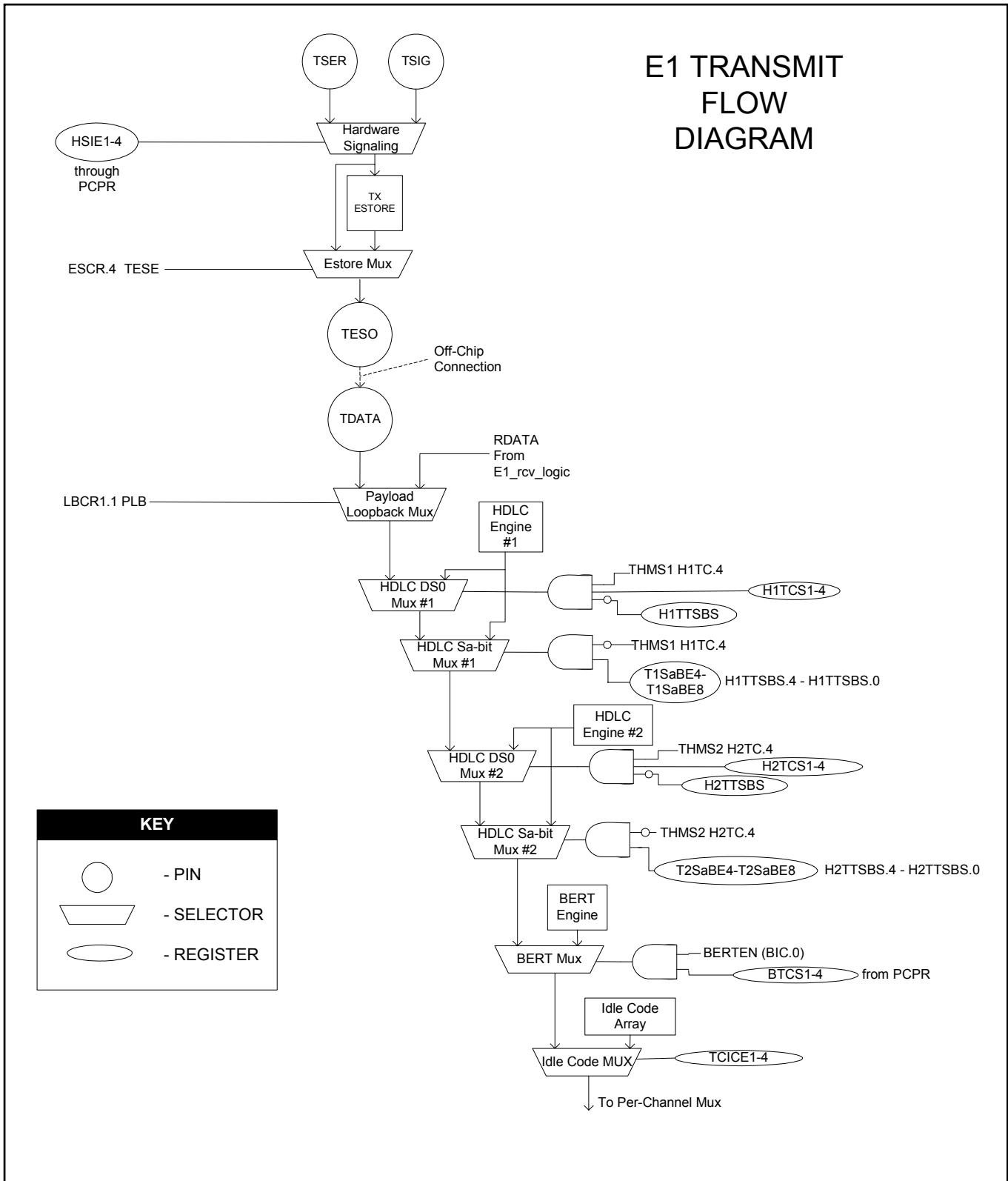
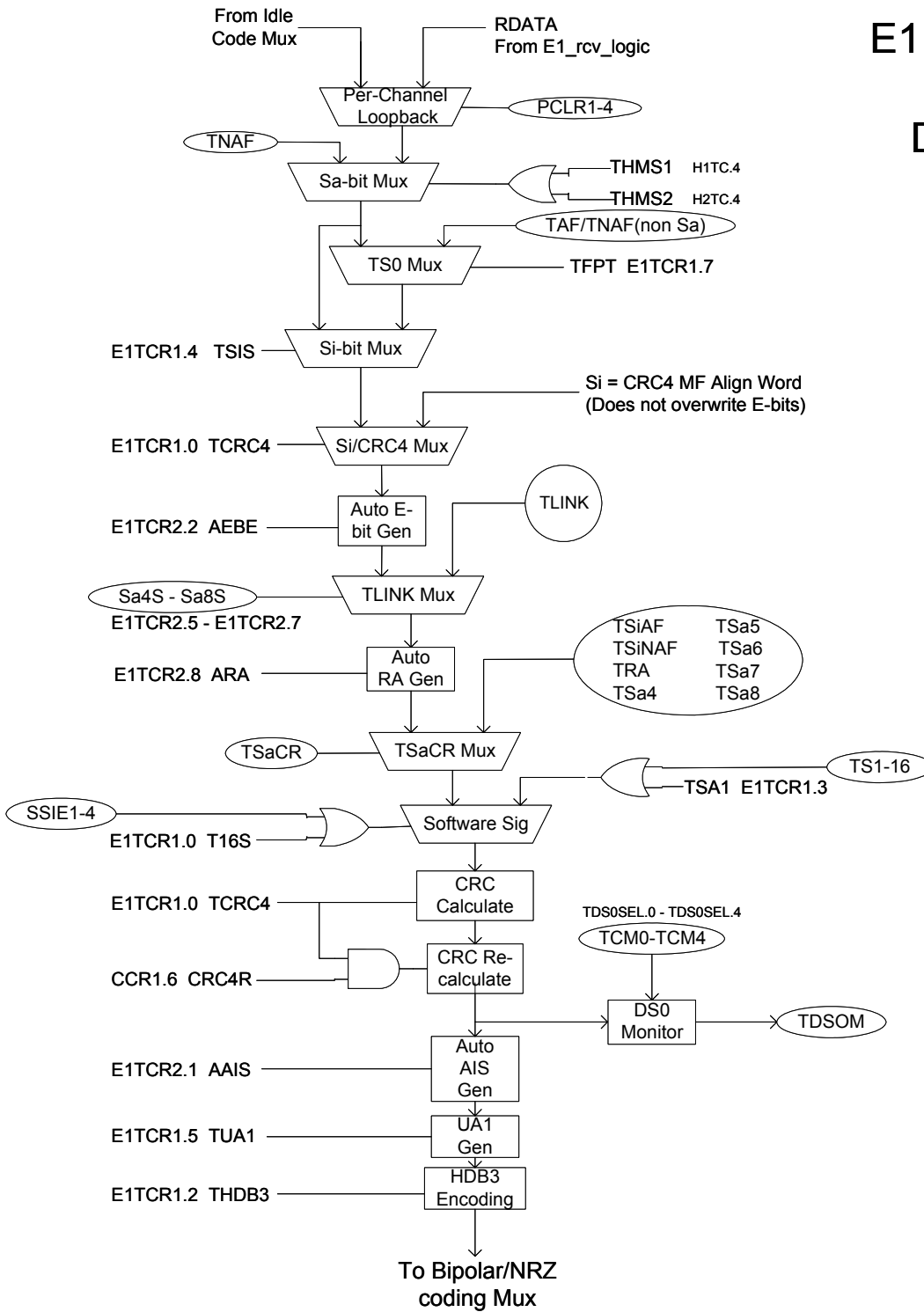

Figure 10-18. E1 Transmit Flow Diagram



E1 TRANSMIT FLOW DIAGRAM



11 DEVICE REGISTERS

Ten address lines are used to address the register space. [Table 11-1](#) shows the register map for the DS33R11. The addressable range for the device is 0000h to 08FFh. Each Register Section is 64 bytes deep. Global Registers are preserved for software compatibility with multiport devices. The Serial Interface (Line) Registers are used to configure the serial port and the associated transport protocol. The Ethernet Interface (Subscriber) registers are used to control and observe each of the Ethernet ports. The registers associated with the MAC must be configured through indirect register write /read access due to the architecture of the device.

When writing to a register input values for unused bits and registers (those designated with “-”) should be zero, as these bits and registers are reserved. When a register is read from, the values of the unused bits and registers should be ignored. A latched status bit is set when an event happens and is cleared when read. The register details are provided in the following tables.

Table 11-1. Register Address Map

MAPPER/ PORT	CHIP SELECT	GLOBAL REGISTERS	ARBITER	BERT	SERIAL INTERFAC E	ETHERNET INTERFACE	T1/E1/J1 TRANSCEIVER
Ethernet Mapper	$\overline{CS}=0$, $\overline{CST}=1$	0000h– 003Fh	0040h– 007Fh	0080h– 00BFh	00C0h– 013Fh	0140h– 17Fh	—
T1/E1/J1 Port 1	$\overline{CS}=1$, $\overline{CST}=0$	—	—	—	—	—	000h–0FFh

11.1 Register Bit Maps

[Table 11-2](#), [Table 11-3](#), [Table 11-4](#), [Table 11-5](#), [Table 11-6](#), and [Table 11-7](#) contain the registers of the DS33R11. Bits that are reserved are noted with a single dash “-”. All registers not listed are reserved and should be initialized with a value of 00h for proper operation, unless otherwise noted.

11.1.1 Global Ethernet Mapper Register Bit Map

Table 11-2. Global Ethernet Mapper Register Bit Map

ADDR	Name	BIT 7	BIT 6	BIT 5	BIT 4	BIT 3	BIT 2	BIT 1	BIT 0
00h	GL.IDRL	ID07	ID06	ID05	ID04	ID03	ID02	ID01	ID00
01h	GL.IDRH	ID15	ID14	ID13	ID12	ID11	ID10	ID09	ID08
02h	GL.CR1	-	-	-	-	-	REF_CLKO	INTM	RST
03h	GL.BLR	-	-	-	-	-	-	-	GL.BLC1
04h	GL.RTCAL	-	-	-	RLCAL1	-	-	-	TLCAL1
05h	GL.SRCALS	-	-	-	-	-	-	REFCLKS	SYSCLS
06h	GL.LIE	-	-	-	LIN1TIE	-	-	-	LIN1RIE
07h	GL.LIS	-	-	-	LIN1TIS	-	-	-	LIN1RIS
08h	GL.SIE	-	-	-	-	-	-	-	SUB1IE
09h	GL.SIS	-	-	-	-	-	-	-	SUB1IS
0Ah	GL.TRQIE	-	-	-	TQ1IE	-	-	-	RQ1IE
0Bh	GL.TRQIS	-	-	-	TQ1IS	-	-	-	RQ1IS
0Ch	GL.BIE	-	-	-	-	-	-	-	BIE
0Dh	GL.BIS	-	-	-	-	-	-	-	BIS
0Eh	GL.CON1	-	-	-	-	-	-	-	LINE0
0Fh	Reserved	-	-	-	-	-	-	-	-
10h	Reserved	-	-	-	-	-	-	-	-
11h	Reserved	-	-	-	-	-	-	-	-
12h	GL.C1QPR	-	-	-	-	C1MRPR	C1HWPR	C1MHPR	C1HRPR
13h	Reserved	-	-	-	-	-	-	-	-
14h	Reserved	-	-	-	-	-	-	-	-
15h	Reserved	-	-	-	-	-	-	-	-
20h	GL.BISTEN	-	-	-	-	-	-	-	BISTE
21h	GL.BISTPF	-	-	-	-	-	-	BISTDN	BISTPF

Note: 22h–3Fh are reserved.

11.1.2 Arbiter Register Bit Map

Table 11-3. Arbiter Register Bit Map

ADDR	NAME	BIT 7	BIT 6	BIT 5	BIT 4	BIT 3	BIT 2	BIT 1	BIT 0
40h	AR.RQSC1	RQSC7	RQSC6	RQSC5	RQSC4	RQSC3	RQSC2	RQSC1	RQSC0
41h	AR.TQSC1	TQSC7	TQSC6	TQSC5	TQSC4	TQSC3	TQSC2	TQSC1	TQSC0

11.1.3 BERT Register Bit Map

Table 11-4. BERT Register Bit Map

ADDR	NAME	BIT 7	BIT 6	BIT 5	BIT 4	BIT 3	BIT 2	BIT 1	BIT 0
080h	BCR	-	PMU	RNPL	RPIC	MPR	APRD	TNPL	TPIC
081h	Reserved	-	-	-	-	-	-	-	-
082h	BPCLR	-	QRSS	PTS	PLF4	PLF3	PLF2	PLF1	PLF0
083h	BPCHR	-	-	-	PTF4	PTF3	PTF2	PTF1	PTF0
084h	BSPB0R	BSP7	BSP6	BSP5	BSP4	BSP3	BSP2	BSP1	BSP0
085h	BSPB1R	BSP15	BSP14	BSP13	BSP12	BSP11	BSP10	BSP9	BSP8
086h	BSPB2R	BSP23	BSP22	BSP21	BSP20	BSP19	BSP18	BSP17	BSP16
087h	BSPB3R	BSP31	BSP30	BSP29	BSP28	BSP27	BSP26	BSP25	BSP24
088h	TEICR	-	-	TIER2	TIER1	TIER0	BEI	TSEI	-
08Ah	Reserved	-	-	-	-	-	-	-	-
08Bh	Reserved	-	-	-	-	-	-	-	-
08Ch	BSR	-	-	-	-	PMS	-	<u>BEC</u>	<u>OOS</u>
08Dh	Reserved	-	-	-	-	-	-	-	-
08Eh	BSRL	-	-	-	-	PMSL	<u>BEL</u>	<u>BEC</u> <u>L</u>	<u>OOS</u> <u>L</u>
08Fh	Reserved	-	-	-	-	-	-	-	-
90h	BSRIE	-	-	-	-	PMSIE	BEIE	BECIE	OOSIE
91h	Reserved	-	-	-	-	-	-	-	-
92h	Reserved	-	-	-	-	-	-	-	-
93h	Reserved	-	-	-	-	-	-	-	-
94h	RBECB0R	<u>BEC7</u>	<u>BEC6</u>	<u>BEC5</u>	<u>BEC4</u>	<u>BEC3</u>	<u>BEC2</u>	<u>BEC1</u>	<u>BEC0</u>
95h	RBECB1R	<u>BEC15</u>	<u>BEC14</u>	<u>BEC13</u>	<u>BEC12</u>	<u>BEC11</u>	<u>BEC10</u>	<u>BEC9</u>	<u>BEC8</u>
96h	RBECB2R	<u>BEC23</u>	<u>BEC22</u>	<u>BEC21</u>	<u>BEC20</u>	<u>BEC19</u>	<u>BEC18</u>	<u>BEC17</u>	<u>BEC16</u>
97h	Reserved	-	-	-	-	-	-	-	-
98h	RBCB0	<u>BC7</u>	<u>BC6</u>	<u>BC5</u>	<u>BC4</u>	<u>BC3</u>	<u>BC2</u>	<u>BC1</u>	<u>BC0</u>
99h	RBCB1	<u>BC15</u>	<u>BC14</u>	<u>BC13</u>	<u>BC12</u>	<u>BC11</u>	<u>BC10</u>	<u>BC9</u>	<u>BC8</u>
9Ah	RBCB2	<u>BC23</u>	<u>BC22</u>	<u>BC21</u>	<u>BC20</u>	<u>BC19</u>	<u>BC18</u>	<u>BC17</u>	<u>BC16</u>
9Bh	RBCB3	<u>BC31</u>	<u>BC30</u>	<u>BC29</u>	<u>BC28</u>	<u>BC27</u>	<u>BC26</u>	<u>BC25</u>	<u>BC24</u>
9Ch	Reserved	-	-	-	-	-	-	-	-
9Dh	Reserved	-	-	-	-	-	-	-	-
9Eh	Reserved	-	-	-	-	-	-	-	-
9Fh	Reserved	-	-	-	-	-	-	-	-

11.1.4 Serial Interface Register Bit Map

Table 11-5. Serial Interface Register Bit Map

ADDR	NAME	BIT 7	BIT 6	BIT 5	BIT 4	BIT 3	BIT 2	BIT 1	BIT 0
0C0h	LI.TSLCR	-	-	-	-	-	-	-	TDENPLT
0C1h	LI.RSTPD	-	-	-	-	-	-	RESET	-
0C2h	LI.LPBK	-	-	-	-	-	-	-	QLP
0C3h	Reserved	-	-	-	-	-	-	-	-
0C4h	LI.TPPCL	-	-	TFAD	TF16	TIFV	TSD	TBRE	-
0C5h	LI.TIFGC	TIFG7	TIFG6	TIFG5	TIFG4	TIFG3	TIFG2	TIFG1	TIFG0
0C6h	LI.TEPLC	TPEN7	TPEN6	TPEN5	TPEN4	TPEN3	TPEN2	TPEN1	TPEN0
0C7h	LI.TEPHC	MEIMS	TPER6	TPER5	TPER4	TPER3	TPER2	TPER1	TPER0
0C8h	LI.TPPSR	-	-	-	-	-	-	-	<u>TEPF</u>
0C9h	LI.TPPSRL	-	-	-	-	-	-	-	<u>TEPFL</u>
0CAh	LI.TPPSRIE	-	-	-	-	-	-	-	TEPFIE
0CBh	Reserved	-	-	-	-	-	-	-	-
0CCh	LI.TPCR0	<u>IPC7</u>	<u>IPC6</u>	<u>IPC5</u>	<u>IPC4</u>	<u>IPC3</u>	<u>IPC2</u>	<u>IPC1</u>	<u>IPC0</u>
0CDh	LI.TPCR1	<u>IPC15</u>	<u>IPC14</u>	<u>IPC13</u>	<u>IPC12</u>	<u>IPC11</u>	<u>IPC10</u>	<u>IPC9</u>	<u>IPC8</u>
0CEh	LI.TPCR2	<u>IPC23</u>	<u>IPC22</u>	<u>IPC21</u>	<u>IPC20</u>	<u>IPC19</u>	<u>IPC18</u>	<u>IPC17</u>	<u>IPC16</u>
0CFh	Reserved	-	-	-	-	-	-	-	-
0D0h	LI.TBCR0	<u>TBC7</u>	<u>TBC6</u>	<u>TBC5</u>	<u>TBC4</u>	<u>TBC3</u>	<u>TBC2</u>	<u>TBC1</u>	<u>TBC0</u>
0D1h	LI.TBCR1	<u>TBC15</u>	<u>TBC14</u>	<u>TBC13</u>	<u>TBC12</u>	<u>TBC11</u>	<u>TBC10</u>	<u>TBC9</u>	<u>TBC8</u>
0D2h	LI.TBCR2	<u>TBC23</u>	<u>TBC22</u>	<u>TBC21</u>	<u>TBC20</u>	<u>TBC19</u>	<u>TBC18</u>	<u>TBC17</u>	<u>TBC16</u>
0D3h	LI.TBCR3	<u>TBC31</u>	<u>TBC30</u>	<u>TBC29</u>	<u>TBC28</u>	<u>TBC27</u>	<u>TBC26</u>	<u>TBC25</u>	<u>TBC24</u>
0D4h	LI.TMEI	-	-	-	-	-	-	-	TMEI
0D5h	Reserved	-	-	-	-	-	-	-	-
0D6h	LI.THPMUU	-	-	-	-	-	-	-	TPMUU
0D7h	LI.THPMUS	-	-	-	-	-	-	-	TPMUS
0D8h	LI.TX86EDE	-	-	-	-	-	-	-	X86ED
0D9h	LI.TRX86A	X86TRA7	X86TRA6	X86TRA5	X86TRA4	X86TRA3	X86TRA2	X86TRA1	X86TRA0
0DAh	LI.TRX8C	X86TRC7	X86TRC6	X86TRC5	X86TRC4	X86TRC3	X86TRC2	X86TRC1	X86TRC0
0DBh	LI.TRX86SAPIH	TRSAPIH7	TRSAPIH6	TRSAPIH5	TRSAPIH4	TRSAPIH3	TRSAPIH2	TRSAPIH1	TRSAPIH0
0DCh	LI.TRX86SAPIL	TRSAPIL7	TRSAPIL6	TRSAPIL5	TRSAPIL4	TRSAPIL3	TRSAPIL2	TRSAPIL1	TRSAPIL0
0DDh	LI.CIR	CIRE	CIR6	CIR5	CIR4	CIR3	CIR2	CIR1	CIR0
100h	LI.RSLCR	-	-	-	-	-	-	-	RDENPLT
101h	LI.RPPCL	-	-	RFPD	RF16	RFED	RDD	RBRE	RCCE
102h	LI.RMPSC	RMX7	RMX6	RMX5	RMX4	RMX3	RMX2	RMX1	RMX0
103h	LI.RMPSCH	RMX15	RMX14	RMX13	RMX12	RMX11	RMX10	RMX9	RMX8
104h	LI.RPPSR	-	-	-	-	-	REPC	RAPC	RSPC
105h	LI.RPPSRL	<u>REPL</u>	<u>RAPL</u>	<u>RIPDL</u>	<u>RSPDL</u>	<u>RLPDL</u>	<u>REPL</u>	<u>RAPCL</u>	<u>RSPCL</u>
106h	LI.RPPSRIE	REPIE	RAPIE	RIPDIE	RSPDIE	RLPDIE	REPCIE	RAPCIE	RSPCIE
107h	Reserved								
108h	LI.RPCB0	<u>RPC7</u>	<u>RPC6</u>	<u>RPC5</u>	<u>RPC4</u>	<u>RPC3</u>	<u>RPC2</u>	<u>RPC1</u>	<u>RPC0</u>
109h	LI.RPCB1	<u>RPC15</u>	<u>RPC14</u>	<u>RPC13</u>	<u>RPC12</u>	<u>RPC11</u>	<u>RPC10</u>	<u>RPC9</u>	<u>RPC8</u>
10Ah	LI.RPCB2	<u>RPC23</u>	<u>RPC22</u>	<u>RPC21</u>	<u>RPC20</u>	<u>RPC19</u>	<u>RPC18</u>	<u>RPC17</u>	<u>RPC16</u>
10Ch	LI.RFPCB0	<u>RFPC7</u>	<u>RFPC6</u>	<u>RFPC5</u>	<u>RFPC4</u>	<u>RFPC3</u>	<u>RFPC2</u>	<u>RFPC1</u>	<u>RFPC0</u>
10Dh	LI.RFPCB1	<u>RFPC15</u>	<u>RFPC14</u>	<u>RFPC13</u>	<u>RFPC12</u>	<u>RFPC11</u>	<u>RFPC10</u>	<u>RFPC9</u>	<u>RFPC8</u>
10Eh	LI.RFPCB2	<u>RFPC23</u>	<u>RFPC22</u>	<u>RFPC21</u>	<u>RFPC20</u>	<u>RFPC19</u>	<u>RFPC18</u>	<u>RFPC17</u>	<u>RFPC16</u>
10Fh	Reserved								
110h	LI.RAPCB0	<u>RAPC7</u>	<u>RAPC6</u>	<u>RAPC5</u>	<u>RAPC4</u>	<u>RAPC3</u>	<u>RAPC2</u>	<u>RAPC1</u>	<u>RAPC0</u>
111h	LI.RAPCB1	<u>RAPC15</u>	<u>RAPC14</u>	<u>RAPC13</u>	<u>RAPC12</u>	<u>RAPC11</u>	<u>RAPC10</u>	<u>RAPC9</u>	<u>RAPC8</u>
112h	LI.RAPCB2	<u>RAPC23</u>	<u>RAPC22</u>	<u>RAPC21</u>	<u>RAPC20</u>	<u>RAPC19</u>	<u>RAPC18</u>	<u>RAPC17</u>	<u>RAPC16</u>
113h	Reserved	-	-	-	-	-	-	-	-

ADDR	NAME	BIT 7	BIT 6	BIT 5	BIT 4	BIT 3	BIT 2	BIT 1	BIT 0
114h	LI.RSPCB0	<u>RSPC7</u>	<u>RSPC6</u>	<u>RSPC5</u>	<u>RSPC4</u>	<u>RSPC3</u>	<u>RSPC2</u>	<u>RSPC1</u>	<u>RSPC0</u>
115h	LI.RSPCB1	<u>RSPC15</u>	<u>RSPC14</u>	<u>RSPC13</u>	<u>RSPC12</u>	<u>RSPC11</u>	<u>RSPC10</u>	<u>RSPC9</u>	<u>RSPC8</u>
116h	LI.RSPCB2	<u>RSPC23</u>	<u>RSPC22</u>	<u>RSPC21</u>	<u>RSPC20</u>	<u>RSPC19</u>	<u>RSPC18</u>	<u>RSPC17</u>	<u>RSPC16</u>
118h	LI.RBC0	<u>RBC7</u>	<u>RBC6</u>	<u>RBC5</u>	<u>RBC4</u>	<u>RBC3</u>	<u>RBC2</u>	<u>RBC1</u>	<u>RBC0</u>
119h	LI.RBC1	<u>RBC15</u>	<u>RBC14</u>	<u>RBC13</u>	<u>RBC12</u>	<u>RBC11</u>	<u>RBC10</u>	<u>RBC9</u>	<u>RBC8</u>
11Ah	LI.RBC2	<u>RBC23</u>	<u>RBC22</u>	<u>RBC21</u>	<u>RBC20</u>	<u>RBC19</u>	<u>RBC18</u>	<u>RBC17</u>	<u>RBC16</u>
11Bh	LI.RBC3	<u>RBC31</u>	<u>RBC30</u>	<u>RBC29</u>	<u>RBC28</u>	<u>RBC27</u>	<u>RBC26</u>	<u>RBC25</u>	<u>RBC24</u>
11Ch	LI.RAC0	<u>REBC7</u>	<u>REBC6</u>	<u>REBC5</u>	<u>REBC4</u>	<u>REBC3</u>	<u>REBC2</u>	<u>REBC1</u>	<u>REBC0</u>
11Dh	LI.RAC1	<u>REBC15</u>	<u>REBC14</u>	<u>REBC13</u>	<u>REBC12</u>	<u>REBC11</u>	<u>REBC10</u>	<u>REBC9</u>	<u>REBC8</u>
11Eh	LI.RAC2	<u>REBC23</u>	<u>REBC22</u>	<u>REBC21</u>	<u>REBC20</u>	<u>REBC19</u>	<u>REBC18</u>	<u>REBC17</u>	<u>REBC16</u>
11Fh	LI.RAC3	<u>REBC31</u>	<u>REBC30</u>	<u>REBC29</u>	<u>REBC28</u>	<u>REBC27</u>	<u>REBC26</u>	<u>REBC25</u>	<u>REBC24</u>
120h	LI.RHPMUU	-	-	-	-	-	-	-	RPMUU
121h	LI.RHPMUS	-	-	-	-	-	-	-	RPMUUS
122h	LI.RX86S	-	-	-	-	SAPIHNE	SAPILNE	CNE	ANE
123h	LI.RX86LSIE	-	-	-	-	SAPINE01IM	SAPINEFEIM	CNE3LIM	ANE4IM
124h	LI.TQLT	<u>TQLT7</u>	<u>TQLT6</u>	<u>TQLT5</u>	<u>TQLT4</u>	<u>TQLT3</u>	<u>TQLT2</u>	<u>TQLT1</u>	<u>TQLT0</u>
125h	LI.TQHT	<u>TQHT7</u>	<u>TQHT6</u>	<u>TQHT5</u>	<u>TQHT4</u>	<u>TQHT3</u>	<u>TQHT2</u>	<u>TQHT1</u>	<u>TQHT0</u>
126h	LI.TQTIE	-	-	-	-	TFOVFIE	TQOVFIE	TQHTIE	TQLTIE
127h	LI.TQCTLS	-	-	-	-	TFOVFLS	TQOVFLS	TQHTLS	TQLTLS

Note: 0DEh–0FFh, 128h–13Fh are reserved.

11.1.5 Ethernet Interface Register Bit Map

Table 11-6. Ethernet Interface Register Bit Map

ADDR	NAME	BIT 7	BIT 6	BIT 5	BIT 4	BIT 3	BIT 2	BIT 1	BIT 0
140h	SU.MACRADL	MACRA7	MACRA6	MACRA5	MACRA4	MACRA3	MACRA2	MACRA1	MACRA0
141h	SU.MACRADH	MACRA15	MACRA14	MACRA13	MACRA12	MACRA11	MACRA10	MACRA09	MACRA08
142h	SU.MACRD0	MACRD7	MACRD6	MACRD5	MACRD4	MACRD3	MACRD2	MACRD1	MACRD0
143h	SU.MACRD1	MACRD15	MACRD14	MACRD13	MACRD12	MACRD11	MACRD10	MACRD9	MACRD8
144h	SU.MACRD2	MACRD23	MACRD22	MACRD21	MACRD20	MACRD19	MACRD18	MACRD17	MACRD16
145h	SU.MACRD3	MACRD31	MACRD30	MACRD29	MACRD28	MACRD27	MACRD26	MACRD25	MACRD24
146h	SU.MACWD0	MACWD7	MACWD6	MACWD5	MACWD4	MACWD3	MACWD2	MACWD1	MACWD0
147h	SU.MACWD1	MACWD15	MACWD14	MACWD13	MACWD12	MACWD11	MACWD10	MACWD09	MACWD08
148h	SU.MACWD2	MACWD23	MACWD22	MACWD21	MACWD20	MACWD19	MACWD18	MACWD17	MACWD16
149h	SU.MACWD3	MACD31	MACD30	MACD29	MACD28	MACD27	MACD26	MACD25	MACD24
14Ah	SU.MACAWL	MACAW 7	MACAW 6	MACAW 5	MACAW4	MACAW3	MACAW2	MACAW1	MACAW0
14Bh	SU.MACAWH	MACAW 15	MACAW 14	MACAW 13	MACAW12	MACAW11	MACAW10	MACAW9	MACAW8
14Ch	SU.MACRWC	-	-	-	-	-	-	MCRW	MCS
14Eh	RESERVED	-	-	-	-	-	-	-	-
14Fh	SU.LPBK	-	-	-	-	-	-	-	QLP
150h	SU.GCR	-	-	-	-	CRCS	H10S	ATFLOW	JAME
151h	SU.TFRC	-	-	-	-	NCFQ	TPDFCB	TPRHBC	TPRCB
152h	SU.TFSL	UR	EC	LC	ED	LOC	NOC	-	FABORT
153h	SU.TFSH	PR	HBF	CC3	CC2	CC1	CC0	LCO	DEF
154h	SU.RFSB0	FL7	FL6	FL5	FL4	FL3	FL2	FL1	FI0
155h	SU.RFSB1	RF	WT	FL13	FL12	FL11	FL10	FL9	FI8
156h	SU.RFSB2	-	-	CRCE	DB	MIIE	FT	CS	FTL
157h	SU.RFSB3	MF	-	-	BF	MCF	UF	CF	LE
158h	SU.RMFSRL	RMPS7	RMPS6	RMPS5	RMPS4	RMPS3	RMPS2	RMPS1	RMPS0
159h	SU.RMFSRH	RMPS15	RMPS14	RMPS13	RMPS12	RMPS11	RMPS10	RMPS09	RMPS08
15Ah	SU.RQLT	RQLT7	RQLT6	RQLT5	RQLT4	RQLT3	RQLT2	RQLT1	RQLT0
15Bh	SU.RQHT	RQHT7	RQHT6	RQHT5	RQHT4	RQHT3	RQHT2	RQHT1	RQHT0
15Ch	SU.QRIE	-	-	-	-	RFOVFIE	RQVFIE	RQLTIE	RQHTIE
15Dh	SU.QCRLS	-	-	-	-	RFOVFLS	RQOVFLS	RQHTLS	RQLTLS
15Eh	SU.RFRC	-	UCFR	CFRR	LERR	CRCERR	DBR	MIIER	BFR

Note: 15Fh–17Fh are reserved.

11.1.6 MAC Register Bit Map

Table 11-7. MAC Indirect Register Bit Map

ADDR	NAME	BIT 7	BIT 6	BIT 5	BIT 4	BIT 3	BIT 2	BIT 1	BIT 0
0000h	SU.MACCR 31:24	Reserved	Reserved	Reserved	HDB	PS	Reserved	Reserved	Reserved
0001h	23:16	DRO	OML1	OML0	F	PM	PAM	Reserved	Reserved
0002h	15:8	Reserved	Reserved	Reserved	LCC	Reserved	DRTY	Reserved	ASTP
0003h	7:0	BOLMT1	BOLMT0	DC	Reserved	TE	RE	Reserved	Reserved
0004h	Reserved	Reserved	Reserved	Reserved	Reserved	Reserved	Reserved	Reserved	Reserved
0005h	Reserved	Reserved	Reserved	Reserved	Reserved	Reserved	Reserved	Reserved	Reserved
0006h	Reserved	Reserved	Reserved	Reserved	Reserved	Reserved	Reserved	Reserved	Reserved
0007h	Reserved	Reserved	Reserved	Reserved	Reserved	Reserved	Reserved	Reserved	Reserved
0008h	Reserved	Reserved	Reserved	Reserved	Reserved	Reserved	Reserved	Reserved	Reserved
0009h	Reserved	Reserved	Reserved	Reserved	Reserved	Reserved	Reserved	Reserved	Reserved
000Ah	Reserved	Reserved	Reserved	Reserved	Reserved	Reserved	Reserved	Reserved	Reserved
000Bh	Reserved	Reserved	Reserved	Reserved	Reserved	Reserved	Reserved	Reserved	Reserved
000Ch	Reserved	Reserved	Reserved	Reserved	Reserved	Reserved	Reserved	Reserved	Reserved
000Dh	Reserved	Reserved	Reserved	Reserved	Reserved	Reserved	Reserved	Reserved	Reserved
000Eh	Reserved	Reserved	Reserved	Reserved	Reserved	Reserved	Reserved	Reserved	Reserved
000Fh	Reserved	Reserved	Reserved	Reserved	Reserved	Reserved	Reserved	Reserved	Reserved
0010h	Reserved	Reserved	Reserved	Reserved	Reserved	Reserved	Reserved	Reserved	Reserved
0011h	Reserved	Reserved	Reserved	Reserved	Reserved	Reserved	Reserved	Reserved	Reserved
0012h	Reserved	Reserved	Reserved	Reserved	Reserved	Reserved	Reserved	Reserved	Reserved
0013h	Reserved	Reserved	Reserved	Reserved	Reserved	Reserved	Reserved	Reserved	Reserved
0014h	SU.MACMIA 31:24	Reserved	Reserved	Reserved	Reserved	Reserved	Reserved	Reserved	Reserved
0015h	23:16	Reserved	Reserved	Reserved	Reserved	Reserved	Reserved	Reserved	Reserved
0016h	15:8	PHYA4	PHYA3	PHYA2	PHYA1	PHYA0	MIIA4	MIIA3	MIIA2
0017h	7:0	MIIA1	MIIA0	Reserved	Reserved	Reserved	Reserved	MIIW	MIIW
0018h	SU.MACMIID 31:24	Reserved	Reserved	Reserved	Reserved	Reserved	Reserved	Reserved	Reserved
0019h	23:16	Reserved	Reserved	Reserved	Reserved	Reserved	Reserved	Reserved	Reserved
001Ah	15:8	MIID15	MIID14	MIID13	MIID12	MIID11	MIID10	MIID09	MIID08
001Bh	7:0	MIID07	MIID06	MIID05	MIID04	MIID03	MIID02	MIID01	MIID00
001Ch	SU.MACFCR 31:24	PT15	PT14	PT13	PT12	PT11	PT10	PT09	PT08
001Dh	23:16	PT07	PT06	PT05	PT04	PT03	PT02	PT01	PT00
001Eh	15:8	Reserved	Reserved	Reserved	Reserved	Reserved	Reserved	Reserved	Reserved
001Fh	7:0	Reserved	Reserved	Reserved	Reserved	Reserved	PCF	FCE	FCB
100h	SU.MMCCTRL 31:24	Reserved	Reserved	Reserved	Reserved	Reserved	Reserved	Reserved	Reserved
101h	23:16	Reserved	Reserved	Reserved	Reserved	Reserved	Reserved	Reserved	Reserved
102h	15:8	Reserved	Reserved	MXFRM10	MXFRM9	MXFRM8	MXFRM7	MXFRM6	MXFRM5
103h	7:0	MXFRM4	MXFRM3	MXFRM2	MXFRM1	MXFRM0	Reserved	Reserved	Reserved
10Ch	RESERVED – initialize to FF	Reserved	Reserved	Reserved	Reserved	Reserved	Reserved	Reserved	Reserved
10Dh	RESERVED – initialize to FF	Reserved	Reserved	Reserved	Reserved	Reserved	Reserved	Reserved	Reserved
10Eh	RESERVED – initialize to FF	Reserved	Reserved	Reserved	Reserved	Reserved	Reserved	Reserved	Reserved
10Fh	RESERVED – initialize to FF	Reserved	Reserved	Reserved	Reserved	Reserved	Reserved	Reserved	Reserved
110h	RESERVED – initialize to FF	Reserved	Reserved	Reserved	Reserved	Reserved	Reserved	Reserved	Reserved
111h	RESERVED – initialize to FF	Reserved	Reserved	Reserved	Reserved	Reserved	Reserved	Reserved	Reserved

ADDR	NAME	BIT 7	BIT 6	BIT 5	BIT 4	BIT 3	BIT 2	BIT 1	BIT 0
112h	RESERVED – initialize to FF	Reserved	Reserved	Reserved	Reserved	Reserved	Reserved	Reserved	Reserved
113h	RESERVED – initialize to FF	Reserved	Reserved	Reserved	Reserved	Reserved	Reserved	Reserved	Reserved
200h	SU.RxFrmCtr 31:24	RXFRMC31	RXFRMC30	RXFRMC29	RXFRMC28	RXFRMC27	RXFRMC26	RXFRMC25	RXFRMC24
201h	23:16	RXFRMC23	RXFRMC22	RXFRMC21	RXFRMC20	RXFRMC19	RXFRMC18	RXFRMC17	RXFRMC16
202h	15:8	RXFRMC15	RXFRMC14	RXFRMC13	RXFRMC12	RXFRMC11	RXFRMC10	RXFRMC9	RXFRMC8
203h	7:0	RXFRMC7	RXFRMC6	RXFRMC5	RXFRMC4	RXFRMC3	RXFRMC2	RXFRMC1	RXFRMC0
204h	SU.RxFrmOKCtr 31:24	RXFRMOK31	RXFRMOK30	RXFRMOK29	RXFRMOK28	RXFRMOK27	RXFRMOK26	RXFRMOK25	RXFRMOK24
205h	23:16	RXFRMOK23	RXFRMOK22	RXFRMOK21	RXFRMOK20	RXFRMOK19	RXFRMOK18	RXFRMOK17	RXFRMOK16
206h	15:8	RXFRMOK15	RXFRMOK14	RXFRMOK13	RXFRMOK12	RXFRMOK11	RXFRMOK10	RXFRMOK9	RXFRMOK8
207h	7:0	RXFRMOK7	RXFRMOK6	RXFRMOK5	RXFRMOK4	RXFRMOK3	RXFRMOK2	RXFRMOK1	RXFRMOK0
300h	SU.TxFrmCtr	TXFRMC31	TXFRMC30	TXFRMC29	TXFRMC28	TXFRMC27	TXFRMC26	TXFRMC25	TXFRMC24
301h	23:16	TXFRMC23	TXFRMC22	TXFRMC21	TXFRMC20	TXFRMC19	TXFRMC18	TXFRMC17	TXFRMC16
302h	15:8	TXFRMC15	TXFRMC14	TXFRMC13	TXFRMC12	TXFRMC11	TXFRMC10	TXFRMC9	TXFRMC8
303h	7:0	TXFRMC7	TXFRMC6	TXFRMC5	TXFRMC4	TXFRMC3	TXFRMC2	TXFRMC1	TXFRMC0
308h	SU.TxBytesCtr	TXBYTEC31	TXBYTEC30	TXBYTEC29	TXBYTEC28	TXBYTEC27	TXBYTEC26	TXBYTEC25	TXBYTEC24
309h	23:16	TXBYTEC23	TXBYTEC22	TXBYTEC21	TXBYTEC20	TXBYTEC19	TXBYTEC18	TXBYTEC17	TXBYTEC16
30Ah	15:8	TXBYTEC15	TXBYTEC14	TXBYTEC13	TXBYTEC12	TXBYTEC11	TXBYTEC10	TXBYTEC9	TXBYTEC8
30Bh	7:0	TXBYTEC7	TXBYTEC6	TXBYTEC5	TXBYTEC4	TXBYTEC3	TXBYTEC2	TXBYTEC1	TXBYTEC0
30Ch	SU.TxBytesOkCtr	TXBYTEOK31	TXBYTEOK30	TXBYTEOK29	TXBYTEOK28	TXBYTEOK27	TXBYTEOK26	TXBYTEOK25	TXBYTEOK24
30Dh	23:16	TXBYTEOK23	TXBYTEOK22	TXBYTEOK21	TXBYTEOK20	TXBYTEOK19	TXBYTEOK18	TXBYTEOK17	TXBYTEOK16
30Eh	15:8	TXBYTEOK15	TXBYTEOK14	TXBYTEOK13	TXBYTEOK12	TXBYTEOK11	TXBYTEOK10	TXBYTEOK9	TXBYTEOK8
30Fh	7:0	TXBYTEOK7	TXBYTEOK6	TXBYTEOK5	TXBYTEOK4	TXBYTEOK3	TXBYTEOK2	TXBYTEOK1	TXBYTEOK0
334h	SU.TxFrmUndr	TXFRMU31	TXFRMU30	TXFRMU29	TXFRMU28	TXFRMU27	TXFRMU26	TXFRMU25	TXFRMU24
335h	23:16	TXFRMU23	TXFRMU22	TXFRMU21	TXFRMU20	TXFRMU19	TXFRMU18	TXFRMU17	TXFRMU16
336h	15:8	TXFRMU15	TXFRMU14	TXFRMU13	TXFRMU12	TXFRMU11	TXFRMU10	TXFRMU9	TXFRMU8
337h	7:0	TXFRMU7	TXFRMU6	TXFRMU5	TXFRMU4	TXFRMU3	TXFRMU2	TXFRMU1	TXFRMU0
338h	SU.TxBdFrmCtr	TXFRMBD31	TXFRMBD30	TXFRMBD29	TXFRMBD28	TXFRMBD27	TXFRMBD26	TXFRMBD25	TXFRMBD24
339h	23:16	TXFRMBD23	TXFRMBD22	TXFRMBD21	TXFRMBD20	TXFRMBD19	TXFRMBD18	TXFRMBD17	TXFRMBD16
33Ah	15:8	TXFRMBD15	TXFRMBD14	TXFRMBD13	TXFRMBD12	TXFRMBD11	TXFRMBD10	TXFRMBD9	TXFRMBD8
33Bh	7:0	TXFRMBD7	TXFRMBD6	TXFRMBD5	TXFRMBD4	TXFRMBD3	TXFRMBD2	TXFRMBD1	TXFRMBD0

Note that the addresses in the table above are the indirect addresses that must be provided to the SU.MACAWH and SU.MACAWL. All unused and reserved locations must be initialized to zero for proper operation.

Table 11-8. T1/E1/J1 Transceiver Register Bit Map (Active when $\overline{CST} = 0$)

ADDR	NAME	BIT 7	BIT 6	BIT 5	BIT 4	BIT 3	BIT 2	BIT 1	BIT 0
000h	TR.MSTRREG	—	—	—	—	TEST1	TEST0	T1/E1	SFTRST
001h	TR.IOCR1	RSMS	RSMS2	RSMS1	RSIO	TSDW	TSM	TSIO	ODF
002h	TR.IOCR2	RDCLKIN V	TDCLKIN V	RSYNCINV	TSYNCINV	TSSYNCINV	H100EN	TSCLKM	RSCLKM
003h	TR.T1RCR1	—	ARC	OOF1	OOF2	SYNCC	SYNCT	SYNCE	RESYNC
004h	TR.T1RCR2	—	RFM	RB8ZS	RSLC96	RZSE	—	RJC	RD4YM
005h	TR.T1TCR1	TJC	TFPT	TCPT	TSSE	GB7S	TFDLS	TBL	TYEL
006h	TR.T1TCR2	TB8ZS	TSLC96	TZSE	FBCT2	FBCT1	TD4YM	Reserved	TB7ZS
007h	TR.T1CCR1	—	—	—	TRAI-CI	TAIS-CI	TFM	PDE	TLOOP
008h	TR.SSIE1-T1 TR.SSIE1-E1	CH8 CH7	CH7 CH6	CH6 CH5	CH5 CH4	CH4 CH3	CH3 CH2	CH2 CH1	CH1 UCAW
009h	TR.SSIE2-T1 TR.SSIE2-E1	CH16 CH15	CH15 CH14	CH14 CH13	CH13 CH12	CH12 CH11	CH11 CH10	CH10 CH9	CH9 CH8
00Ah	TR.SSIE3-T1 TR.SSIE3-E1	CH24 CH22	CH23 CH21	CH22 CH20	CH21 CH19	CH20 CH18	CH19 CH17	CH18 CH16	CH17 LCAW
00Bh	TR.SSIE4	CH30	CH29	CH28	CH27	CH26	CH25	CH24	CH23
00Ch	TR.T1RDMR1	CH8	CH7	CH6	CH5	CH4	CH3	CH2	CH1
00Dh	TR.T1RDMR2	CH16	CH15	CH14	CH13	CH12	CH11	CH10	CH9
00Eh	TR.T1RDMR3	CH24	CH23	CH22	CH21	CH20	CH19	CH18	CH17
00Fh	TR.IDR	ID7	ID6	ID5	ID4	ID3	ID2	ID1	ID0
010h	TR.INFO1	RPDV	TPDV	COFA	8ZD	16ZD	SEFE	B8ZS	FBE
011h	TR.INFO2	BSYNC	BD	TCLE	TOCD	RL3	RL2	RL1	RL0
012h	TR.INFO3	—	—	—	—	—	CRCRC	FASRC	CASRC
013h	Reserved	—	—	—	—	—	—	—	—
014h	TR.IIR1	SR8	SR7	SR6	SR5	SR4	SR3	SR2	SR1
015h	TR.IIR2	—	—	—	—	—	—	—	SR9
016h	TR.SR1	ILUT	TIMER	RSCOS	JALT	LRCL	TCLE	TOCD	LOLITC
017h	TR.IMR1	ILUT	TIMER	RSCOS	JALT	LRCL	TCLE	TOCD	LOLITC
018h	TR.SR2	RYELC	RUA1C	FRCLC	RLOSC	RYEL	RUA1	FRCL	RLOS
019h	TR.IMR2	RYELC	RUA1C	FRCLC	RLOSC	RYEL	RUA1	FRCL	RLOS

ADD R	NAME	BIT 7	BIT 6	BIT 5	BIT 4	BIT 3	BIT 2	BIT 1	BIT 0
h									
01A h	TR.SR3	LSPARE	LDN	LUP	LOTC	LORC	V52LNK	RDMA	RRA
01B h	TR.IMR3	LSPARE	LDN	LUP	LOTC	LORC	V52LNK	RDMA	RRA
01C h	TR.SR4	RAIS-CI	RSA1	RSA0	TMF	TAF	RMF	RCMF	RAF
01D h	TR.IMR4	RAIS-CI	RSA1	RSA0	TMF	TAF	RMF	RCMF	RAF
01E h	TR.SR5	—	—	TESF	TESEM	TSLIP	RESF	RESEM	RSLIP
01F h	TR.IMR5	—	—	TESF	TESEM	TSLIP	RESF	RESEM	RSLIP
020 h	TR.SR6	—	TMEND	RPE	RPS	RHWM	RNE	TLWM	TNF
021 h	TR.IMR6	—	TMEND	RPE	RPS	RHWM	RNE	TLWM	TNF
022 h	TR.SR7	—	TMEND	RPE	RPS	RHWM	RNE	TLWM	TNF
023 h	TR.IMR7	—	TMEND	RPE	RPS	RHWM	RNE	TLWM	TNF
024 h	TR.SR8	—	—	BOCC	RFDLAD	RFDLF	TFDLE	RMTCH	RBOC
025 h	TR.IMR8	—	—	BOCC	RFDLAD	RFDLF	TFDLE	RMTCH	RBOC
026 h	TR.SR9	—	BBED	BBCO	BEC0	BRA1	BRA0	BRLOS	BSYNC
027 h	TR.IMR9	—	BBED	BBCO	BEC0	BRA1	BRA0	BRLOS	BSYNC
028 h	TR.PCPR	RSAOICS	RSRCS	RFCS	BRCS	THSCS	PEICS	TFCS	BTCS
029 h	TR.PCDR1	CH8	CH7	CH6	CH5	CH4	CH3	CH2	CH1
02A h	TR.PCDR2	CH16	CH15	CH14	CH13	CH12	CH11	CH10	CH9
02B h	TR.PCDR3	CH24	CH23	CH22	CH21	CH20	CH19	CH18	CH17
02C h	TR.PCDR4	CH32	CH31	CH30	CH29	CH28	CH27	CH26	CH25
02D h	TR.INFO4	—	—	—	—	H2UDR	H2OBT	H1UDR	H1OBT
02E h	TR.INFO5	—	—	EMPTY	TFULL	EMPTY	PS2	PS1	PS0
02F h	TR.INFO6	—	—	EMPTY	TFULL	EMPTY	PS2	PS1	PS0
030 h	TR.INFO7	CSC5	CSC4	CSC3	CSC2	CSC0	FASSA	CASSA	CRC4SA
031 h	TR.H1RC	RHR	RHMS	—	—	HDLCD	—	—	RSFD
032 h	TR.H2RC	RHR	RHMS	—	—	HDLCD	—	—	RSFD
033 h	TR.E1RCR1	RSERC	RSIGM	RHDB3	RG802	RCRC4	FRC	SYNCE	RESYNC
034 h	TR.E1RCR2	—	—	—	—	—	—	—	RCLA

ADD R	NAME	BIT 7	BIT 6	BIT 5	BIT 4	BIT 3	BIT 2	BIT 1	BIT 0
h									
035 h	TR.E1TCR1	TFPT	T16S	TUA1	TSiS	TSA1	THDB3	TG802	TCRC4
036 h	TR.E1TCR2	Reserved	Reserved	Reserved	Reserved	Reserved	AEBE	AAIS	ARA
037 h	TR.BOCC	—	—	—	RBOCE	RBR	RBF1	RBF0	SBOC
038 h	TR.RSINFO1	CH8	CH7	CH6	CH5	CH4	CH3	CH2	CH1
039 h	TR.RSINFO2	CH16	CH15	CH14	CH13	CH12	CH11	CH10	CH9
03A h	TR.RSINFO3	CH24	CH23	CH22	CH21	CH20	CH19	CH18	CH17
03B h	TR.RSINFO4	—	—	CH30	CH29	CH28	CH27	CH26	CH25
03C h	TR.RSCSE1	CH8	CH7	CH6	CH5	CH4	CH3	CH2	CH1
03D h	TR.RSCSE2	CH16	CH15	CH14	CH13	CH12	CH11	CH10	CH9
03E h	TR.RSCSE3	CH24	CH23	CH22	CH21	CH20	CH19	CH18	CH17
03F h	TR.RSCSE4	—	—	CH30	CH29	CH28	CH27	CH26	CH25
040 h	TR.SIGCR	GRSRE	—	—	RFE	RFF	RCCS	TCCS	FRSAO
041 h	TR.ERCNT	—	MECU	ECUS	EAMS	VCRFS	FSBE	MOSCRF	LCVCRF
042 h	TR.LCVCR1	LCVC15	LCVC14	LCVC13	LCVC12	LCVC11	LCVC10	LCVC9	LCCV8
043 h	TR.LCVCR2	LCVC7	LCVC6	LCVC5	LCVC4	LCVC3	LCVC2	LCVC1	LCVC0
044 h	TR.PCVCR1	PCVC15	PCVC14	PCVC13	PCVC12	PCVC11	PCVC10	PCVC9	PCVC8
045 h	TR.PCVCR2	PCVC7	PCVC6	PCVC5	PCVC4	PCVC3	PCVC2	PCVC1	PCVC0
046 h	TR.FOSCR1	FOS15	FOS14	FOS13	FOS12	FOS11	FOS10	FOS9	FOS8
047 h	TR.FOSCR2	FOS7	FOS6	FOS5	FOS4	FOS3	FOS2	FOS1	FOS0
048 h	TR.EBCR1	EB15	EB14	EB13	EB12	EB11	EB10	EB9	EB8
049 h	TR.EBCR2	EB7	EB6	EB5	EB4	EB3	EB2	EB1	EB0
04A h	TR.LBCR	LTS	—	—	LIUC	LLB	RLB	PLB	FLB
04B h	TR.PCLR1	CH8	CH7	CH6	CH5	CH4	CH3	CH2	CH1
04C h	TR.PCLR2	CH16	CH15	CH14	CH13	CH12	CH11	CH10	CH9
04D h	TR.PCLR3	CH24	CH23	CH22	CH21	CH20	CH19	CH18	CH17
04E h	TR.PCLR4	CH32	CH31	CH30	CH29	CH28	CH27	CH26	CH25
04F	TR.ESCR	TESALGN	TESR	TESMDM	TESE	RESALGN	RESR	RESMDM	RESE

ADD R	NAME	BIT 7	BIT 6	BIT 5	BIT 4	BIT 3	BIT 2	BIT 1	BIT 0
h									
050 h	TR.TS1	Transmit Signaling Bit Format Changes With Operating Mode. See Register Definition.							
051 h	TR.TS2	Transmit Signaling Bit Format Changes With Operating Mode. See Register Definition.							
052 h	TR.TS3	Transmit Signaling Bit Format Changes With Operating Mode. See Register Definition.							
053 h	TR.TS4	Transmit Signaling Bit Format Changes With Operating Mode. See Register Definition.							
054 h	TR.TS5	Transmit Signaling Bit Format Changes With Operating Mode. See Register Definition.							
055 h	TR.TS6	Transmit Signaling Bit Format Changes With Operating Mode. See Register Definition.							
056 h	TR.TS7	Transmit Signaling Bit Format Changes With Operating Mode. See Register Definition.							
057 h	TR.TS8	Transmit Signaling Bit Format Changes With Operating Mode. See Register Definition.							
058 h	TR.TS9	Transmit Signaling Bit Format Changes With Operating Mode. See Register Definition.							
059 h	TR.TS10	Transmit Signaling Bit Format Changes With Operating Mode. See Register Definition.							
05A h	TR.TS11	Transmit Signaling Bit Format Changes With Operating Mode. See Register Definition.							
05B h	TR.TS12	Transmit Signaling Bit Format Changes With Operating Mode. See Register Definition.							
05C h	TR.TS13	Transmit Signaling Bit Format Changes With Operating Mode. See Register Definition.							
05D h	TR.TS14	Transmit Signaling Bit Format Changes With Operating Mode. See Register Definition.							
05E h	TR.TS15	Transmit Signaling Bit Format Changes With Operating Mode. See Register Definition.							
05F h	TR.TS16	Transmit Signaling Bit Format Changes With Operating Mode. See Register Definition.							
060 h	TR.RS1	Receive Signaling Bit Format Changes With Operating Mode. See Register Definition.							
061 h	TR.RS2	Receive Signaling Bit Format Changes With Operating Mode. See Register Definition.							
062 h	TR.RS3	Receive Signaling Bit Format Changes With Operating Mode. See Register Definition.							
063 h	TR.RS4	Receive Signaling Bit Format Changes With Operating Mode. See Register Definition.							
064 h	TR.RS5	Receive Signaling Bit Format Changes With Operating Mode. See Register Definition.							
065 h	TR.RS6	Receive Signaling Bit Format Changes With Operating Mode. See Register Definition.							
066 h	TR.RS7	Receive Signaling Bit Format Changes With Operating Mode. See Register Definition.							
067 h	TR.RS8	Receive Signaling Bit Format Changes With Operating Mode. See Register Definition.							
068 h	TR.RS9	Receive Signaling Bit Format Changes With Operating Mode. See Register Definition.							
069 h	TR.RS10	Receive Signaling Bit Format Changes With Operating Mode. See Register Definition.							

ADD R	NAME	BIT 7	BIT 6	BIT 5	BIT 4	BIT 3	BIT 2	BIT 1	BIT 0
06A h	TR.RS11	Receive Signaling Bit Format Changes With Operating Mode. See Register Definition.							
06B h	TR.RS12	Receive Signaling Bit Format Changes With Operating Mode. See Register Definition.							
06C h	TR.RS13	Receive Signaling Bit Format Changes With Operating Mode. See Register Definition.							
06D h	TR.RS14	Receive Signaling Bit Format Changes With Operating Mode. See Register Definition.							
06E h	TR.RS15	Receive Signaling Bit Format Changes With Operating Mode. See Register Definition.							
06F h	TR.RS16	Receive Signaling Bit Format Changes With Operating Mode. See Register Definition.							
070 h	TR.CCR1	—	CRC4R	SIE	ODM	—	TCSS1	TCSS0	RLOSF
071 h	TR.CCR2	—	—	—	—	—	BPCS1	BPCS0	BPEN
072 h	TR.CCR3	—	—	—	—	TDATFMT	TGPCKEN	RDATFMT	RGPCKEN
073 h	TR.CCR4	RLT3	RLT2	RLT1	RLT0	UOP3	UOP2	UOP1	UOP0
074 h	TR.TDS0SEL	—	—	—	TCM4	TCM3	TCM2	TCM1	TCM0
075 h	TR.TDS0M	B1	B2	B3	B4	B5	B6	B7	B8
076 h	TR.RDS0SEL	—	—	—	RCM4	RCM3	RCM2	RCM1	RCM0
077 h	TR.RDS0M	B1	B2	B3	B4	B5	B6	B7	B8
078 h	TR.LIC1	L2	L1	L0	EGL	JAS	JABDS	DJA	TPD
079 h	TR.LIC2	ETS	LIRST	IBPV	TUA1	JAMUX	—	SCLD	CLDS
07A h	TR.LIC3	—	TCES	RCES	MM1	MM0	RSCLKE	TSCLKE	TAOZ
07B h	TR.LIC4	CMIE	CMII	MPS1	MPS0	TT1	TT0	RT1	RT0
07C h	Reserved	—	—	—	—	—	—	—	—
07D h	TR.TLBC	—	AGCD	GC5	GC4	GC3	GC2	GC1	GC0
07E h	TR.IAAR	GRIC	GTIC	IAA5	IAA4	IAA3	IAA2	IAA1	IAA0
07F h	TR.PCICR	C7	C6	C5	C4	C3	C2	C1	C0
080 h	TR.TCICE1	CH8	CH7	CH6	CH5	CH4	CH3	CH2	CH1
081 h	TR.TCICE2	CH16	CH15	CH14	CH13	CH12	CH11	CH10	CH9
082 h	TR.TCICE3	CH24	CH23	CH22	CH21	CH20	CH19	CH18	CH17
083 h	TR.TCICE4	CH32	CH31	CH30	CH29	CH28	CH27	CH26	CH25
084 h	TR.RCICE1	CH8	CH7	CH6	CH5	CH4	CH3	CH2	CH1

ADD R	NAME	BIT 7	BIT 6	BIT 5	BIT 4	BIT 3	BIT 2	BIT 1	BIT 0
085h	TR.RCICE2	CH16	CH15	CH14	CH13	CH12	CH11	CH10	CH9
086h	TR.RCICE3	CH24	CH23	CH22	CH21	CH20	CH19	CH18	CH17
087h	TR.RCICE4	CH32	CH31	CH30	CH29	CH28	CH27	CH26	CH25
088h	TR.RCIBR1	CH8	CH7	CH6	CH5	CH4	CH3	CH2	CH1
089h	TR.RCIBR2	CH16	CH15	CH14	CH13	CH12	CH11	CH10	CH9
08Ah	TR.RCIBR3	CH24	CH23	CH22	CH21	CH20	CH19	CH18	CH17
08Bh	TR.RCIBR4	CH32	CH31	CH30	CH29	CH28	CH27	CH26	CH25
08Ch	TR.TCIBR1	CH8	CH7	CH6	CH5	CH4	CH3	CH2	CH1
08Dh	TR.TCIBR2	CH16	CH15	CH14	CH13	CH12	CH11	CH10	CH9
08Eh	TR.TCIBR3	CH24	CH23	CH22	CH21	CH20	CH19	CH18	CH17
08Fh	TR.TCIBR4	CH32	CH31	CH30	CH29	CH28	CH27	CH26	CH25
090h	TR.H1TC	NOFS	TEOML	THR	THMS	TFS	TEOM	TZSD	TCRCD
091h	TR.H1FC	—	—	TFLWM2	TFLWM1	TFLWM0	RFHWM2	RFHWM1	RFHWM0
092h	TR.H1RCS1	RHCS8	RHCS7	RHCS6	RHCS5	RHCS4	RHCS3	RHCS2	RHCS1
093h	TR.H1RCS2	RHCS16	RHCS15	RHCS14	RHCS13	RHCS12	RHCS11	RHCS10	RHCS9
094h	TR.H1RCS3	RHCS24	RHCS23	RHCS22	RHCS21	RHCS20	RHCS19	RHCS18	RHCS17
095h	TR.H1RCS4	RHCS32	RHCS31	RHCS30	RHCS29	RHCS28	RHCS27	RHCS26	RHCS25
096h	TR.H1RTSBS	RCB8SE	RCB7SE	RCB6SE	RCB5SE	RCB4SE	RCB3SE	RCB2SE	RCB1SE
097h	TR.H1TCS1	THCS8	THCS7	THCS6	THCS5	THCS4	THCS3	THCS2	THCS1
098h	TR.H1TCS2	THCS16	THCS15	THCS14	THCS13	THCS12	THCS11	THCS10	THCS9
099h	TR.H1TCS3	THCS24	THCS23	THCS22	THCS21	THCS20	THCS19	THCS18	THCS17
09Ah	TR.H1TCS4	THCS32	THCS31	THCS30	THCS29	THCS28	THCS27	THCS26	THCS25
09Bh	TR.H1TTSBS	TCB8SE	TCB7SE	TCB6SE	TCB5SE	TCB4SE	TCB3SE	TCB2SE	TCB1SE
09Ch	TR.H1RPBA	MS	RPBA6	RPBA5	RPBA4	RPBA3	RPBA2	RPBA1	RPBA0
09Dh	TR.H1TF	THD7	THD6	THD5	THD4	THD3	THD2	THD1	THD0
09Eh	TR.H1RF	RHD7	RHD6	RHD5	RHD4	RHD3	RHD2	RHD1	RHD0
09Fh	TR.H1TFBA	TFBA7	TFBA6	TFBA5	TFBA4	TFBA3	TFBA2	TFBA1	TFBA0

ADD R	NAME	BIT 7	BIT 6	BIT 5	BIT 4	BIT 3	BIT 2	BIT 1	BIT 0
0A0 h	TR.H2TC	NOFS	TEOML	THR	THMS	TFS	TEOM	TZSD	TCRCD
0A1 h	TR.H2FC	—	—	TFLWM2	TFLWM1	TFLWM0	RFHWM2	RFHWM1	RFHWM0
0A2 h	TR.H2RCS1	RHCS8	RHCS7	RHCS6	RHCS5	RHCS4	RHCS3	RHCS2	RHCS1
0A3 h	TR.H2RCS2	RHCS16	RHCS15	RHCS14	RHCS13	RHCS12	RHCS11	RHCS10	RHCS9
0A4 h	TR.H2RCS3	RHCS24	RHCS23	RHCS22	RHCS21	RHCS20	RHCS19	RHCS18	RHCS17
0A5 h	TR.H2RCS4	RHCS32	RHCS31	RHCS30	RHCS29	RHCS28	RHCS27	RHCS26	RHCS25
0A6 h	TR.H2RTSBS	RCB8SE	RCB7SE	RCB6SE	RCB5SE	RCB4SE	RCB3SE	RCB2SE	RCB1SE
0A7 h	TR.H2TCS1	THCS8	THCS7	THCS6	THCS5	THCS4	THCS3	THCS2	THCS1
0A8 h	TR.H2TCS2	THCS16	THCS15	THCS14	THCS13	THCS12	THCS11	THCS10	THCS9
0A9 h	TR.H2TCS3	THCS24	THCS23	THCS22	THCS21	THCS20	THCS19	THCS18	THCS17
0AA h	TR.H2TCS4	THCS32	THCS31	THCS30	THCS29	THCS28	THCS27	THCS26	THCS25
0AB h	TR.H2TTSBS	TCB8SE	TCB7SE	TCB6SE	TCB5SE	TCB4SE	TCB3SE	TCB2SE	TCB1SE
0AC h	TR.H2RPBA	MS	RPBA6	RPBA5	RPBA4	RPBA3	RPBA2	RPBA1	RPBA0
0AD h	TR.H2TF	THD7	THD6	THD5	THD4	THD3	THD2	THD1	THD0
0AE h	TR.H2RF	RHD7	RHD6	RHD5	RHD4	RHD3	RHD2	RHD1	RHD0
0AF h	TR.H2TFBA	TFBA7	TFBA6	TFBA5	TFBA4	TFBA3	TFBA2	TFBA1	TFBA0
0B6 h	TR.IBCC	TC1	TC0	RUP2	RUP1	RUP0	RDN2	RDN1	RDN0
0B7 h	TR.TCD1	C7	C6	C5	C4	C3	C2	C1	C0
0B8 h	TR.TCD2	C7	C6	C5	C4	C3	C2	C1	C0
0B9 h	TR.RUPCD1	C7	C6	C5	C4	C3	C2	C1	C0
0BA h	TR.RUPCD2	C7	C6	C5	C4	C3	C2	C1	C0
0BB h	TR.RDNCD1	C7	C6	C5	C4	C3	C2	C1	C0
0BC h	TR.RDNCD2	C7	C6	C5	C4	C3	C2	C1	C0
0BD h	TR.RSCC	—	—	—	—	—	RSC2	RSC1	RSC0
0BE h	TR.RSCD1	C7	C6	C5	C4	C3	C2	C1	C0
0BF h	TR.RSCD2	C7	C6	C5	C4	C3	C2	C1	C0
0C0 h	TR.RFDL	Bit Definitions Change With BOCC Setting. See Register Definition.							

ADD R	NAME	BIT 7	BIT 6	BIT 5	BIT 4	BIT 3	BIT 2	BIT 1	BIT 0
0C1h	TR.TFDL	TFDL7	TFDL6	TFDL5	TFDL4	TFDL3	TFDL2	TFDL1	TFDL0
0C2h	TR.RFDLM1	RFDLM7	RFDLM6	RFDLM5	RFDLM4	RFDLM3	RFDLM2	RFDLM1	RFDLM0
0C3h	TR.RFDLM2	RFDLM7	RFDLM6	RFDLM5	RFDLM4	RFDLM3	RFDLM2	RFDLM1	RFDLM0
0C3h	Reserved	—	—	—	—	—	—	—	—
0C5h	Reserved	—	—	—	—	—	—	—	—
0C6h	TR.RAF	Si	0	0	1	1	0	1	1
0C7h	TR.RNAF	Si	1	A	Sa4	Sa5	Sa6	Sa7	Sa8
0C8h	TR.RSiAF	SiF0	SiF2	SiF4	SiF6	SiF8	SiF10	SiF12	SiF14
0C9h	TR.RSiNAF	SiF1	SiF3	SiF5	SiF7	SiF9	SiF11	SiF13	SiF15
0CAh	TR.RRA	RRAF1	RRAF3	RRAF5	RRAF7	RRAF9	RRAF11	RRAF13	RRAF15
0CBh	TR.RSa4	RSa4F1	RSa4F3	RSa4F5	RSa4F7	RSa4F9	RSa4F11	RSa4F13	RSa4F15
0CCh	TR.RSa5	RSa5F1	RSa5F3	RSa5F5	RSa5F7	RSa5F9	RSa5F11	RSa5F13	RSa5F15
0CDh	TR.RSa6	RSa6F1	RSa6F3	RSa6F5	RSa6F7	RSa6F9	RSa6F11	RSa6F13	RSa6F15
0CEh	TR.RSa7	RSa7F1	RSa7F3	RSa7F5	RSa7F7	RSa7F9	RSa7F11	RSa7F13	RSa7F15
0CFh	TR.RSa8	RSa8F1	RSa8F3	RSa8F5	RSa8F7	RSa8F9	RSa8F11	RSa8F13	RSa8F15
0D0h	TR.TAF	Si	0	0	1	1	0	1	1
0D1h	TR.TNAF	Si	1	A	Sa4	Sa5	Sa6	Sa7	Sa8
0D2h	TR.TSiAF	TsiF0	TsiF2	TsiF4	TsiF6	TsiF8	TsiF10	TsiF12	TsiF14
0D3h	TR.TSiNAF	TsiF1	TsiF3	TsiF5	TsiF7	TsiF9	TsiF11	TsiF13	TSiF15
0D4h	TR.TRA	TRAF1	TRAF3	TRAF5	TRAF7	TRAF9	TRAF11	TRAF13	TRAF15
0D5h	TR.TSa4	TSa4F1	TSa4F3	TSa4F5	TSa4F7	TSa4F9	TSa4F11	TSa4F13	TSa4F15
0D6h	TR.TSa5	TSa5F1	TSa5F3	TSa5F5	TSa5F7	TSa5F9	TSa5F11	TSa5F13	TSa5F15
0D7h	TR.TSa6	TSa6F1	TSa6F3	TSa6F5	TSa6F7	TSa6F9	TSa6F11	TSa6F13	TSa6F15
0D8h	TR.TSa7	TSa7F1	TSa7F3	TSa7F5	TSa7F7	TSa7F9	TSa7F11	TSa7F13	TSa7F15
0D9h	TR.TSa8	TSa8F1	TSa8F3	TSa8F5	TSa8F7	TSa8F9	TSa8F11	TSa8F13	TSa8F15
0DAh	TR.TSACR	SiAF	SiNAF	RA	Sa4	Sa5	Sa6	Sa7	Sa8
0DBh	TR.BAWC	ACNT7	ACNT6	ACNT5	ACNT4	ACNT3	ACNT2	ACNT1	ACNT0

ADDR	NAME	BIT 7	BIT 6	BIT 5	BIT 4	BIT 3	BIT 2	BIT 1	BIT 0
0DCh	TR.BRP1	RPAT7	RPAT6	RPAT5	RPAT4	RPAT3	RPAT2	RPAT1	RPAT0
0DDh	TR.BRP2	RPAT15	RPAT14	RPAT13	RPAT12	RPAT11	RPAT10	RPAT9	RPAT8
0DEh	TR.BRP3	RPAT23	RPAT22	RPAT21	RPAT20	RPAT19	RPAT18	RPAT17	RPAT16
0DFh	TR.BRP4	RPAT31	RPAT30	RPAT29	RPAT28	RPAT27	RPAT26	RPAT25	RPAT24
0E0h	TR.BC1	TC	TINV	RINV	PS2	PS1	PS0	LC	RESYNC
0E1h	TR.BC2	EIB2	EIB1	EIB0	SBE	RPL3	RPL2	RPL1	RPL0
0E2h	Reserved	—	—	—	—	—	—	—	—
0E3h	TR.BBC1	BBC7	BBC6	BBC5	BBC4	BBC3	BBC2	BBC1	BBC0
0E4h	TR.BBC2	BBC15	BBC14	BBC13	BBC12	BBC11	BBC10	BBC9	BBC8
0E5h	TR.BBC3	BBC23	BBC22	BBC21	BBC20	BBC19	BBC18	BBC17	BBC16
0E6h	TR.BBC4	BBC31	BBC30	BBC29	BBC28	BBC27	BBC26	BBC25	BBC24
0E7h	TR.BEC1	EC7	EC6	EC5	EC4	EC3	EC2	EC1	EC0
0E8h	TR.BEC2	EC15	EC14	EC13	EC12	EC11	EC10	EC9	EC8
0E9h	TR.BEC3	EC23	EC22	EC21	EC20	EC19	EC18	EC17	EC16
0EAh	TR.BIC	—	RFUS	—	TBAT	TFUS	—	BERTDIR	BERTEN
0EBh	TR.ERC	WNOE	—	—	CE	ER3	ER2	ER1	ER0
0EC h	TR.NOE1	C7	C6	C5	C4	C3	C2	C1	C0
0ED h	TR.NOE2	—	—	—	—	—	—	C9	C8
0EE h	TR.NOEL1	C7	C6	C5	C4	C3	C2	C1	C0
0EF h	TR.NOEL2	—	—	—	—	—	—	C9	C8

11.2 Global Register Definitions for Ethernet Mapper

Functions contained in the global registers include: framer reset, LIU reset, device ID, and BERT interrupt status. These registers are preserved to provide code compatibility with the multiport devices in this product family. The global registers bit descriptions are presented below.

Register Name: **GL.IDRL**
 Register Description: **Global ID Low Register**
 Register Address: **00h**

Bit #	7	6	5	4	3	2	1	0
Name	<u>ID07</u>	<u>ID06</u>	<u>ID05</u>	<u>ID04</u>	<u>ID03</u>	<u>ID02</u>	<u>ID01</u>	<u>ID00</u>
Default	0	0	1	1	0	0	0	0

Bit 7: ID07 Reserved for future use

Bit 6: ID06 Reserved for future use

Bit 5: ID05 If this bit is set the device contains a RMII interface

Bit 4: ID04 If this bit is set the device contains a MII interface

Bit 3: ID03 If this bit is set the device contains an Ethernet PHY

Bits 0-2: ID00-ID02 A three-bit count that is equal to 000b for the first die revision, and is incremented with each successive die revision. May not match the two-letter die revision code on the top brand of the device.

Register Name: **GL.IDRH**
 Register Description: **Global ID High Register**
 Register Address: **01h**

Bit #	7	6	5	4	3	2	1	0
Name	<u>ID15</u>	<u>ID14</u>	<u>ID13</u>	<u>ID12</u>	<u>ID11</u>	<u>ID10</u>	<u>ID09</u>	<u>ID08</u>
Default	0	0	0	0	0	0	1	0

Bits 5-7: ID13-15 Number of Ethernet ports in the device minus 1. (i.e. 000 = 1 Ethernet port)

Bit 4: ID12 If this bit is set the device has LIU functionality

Bit 3: ID11 If this bit is set the device has a framer

Bit 2: ID10 Reserved for future use

Bit 1: ID09 If this bit is set the device has HDLC or X.86 encapsulation

Bit 0: ID08 If this bit is set the device has inverse multiplexing functionality

Register Name: **GL.CR1**
 Register Description: **Global Control Register 1**
 Register Address: **02h**

Bit #	7	6	5	4	3	2	1	0
Name	-	-	-	-	-	REF_CLKO	INTM	RST
Default						0	0	0

Bit 2: REF_CLKO OFF (REF_CLKO) This bit determines if the REF_CLKO is turned off

- 1 = REF_CLKO is disabled and outputs an active low signal.
- 0 = REF_CLKO is active and in accordance with RMII/MII Selection

Bit 1: $\overline{\text{INT}}$ pin mode (INTM) This bit determines the inactive mode of the $\overline{\text{INT}}$ pin. The $\overline{\text{INT}}$ pin always drives low when active.

- 1 = Pin is high impedence when not active
- 0 = Pin drives high when not active

Bit 0: Reset (RST). When this bit is set to 1, all of the internal data path and status and control registers (except this RST bit), on all ports, are reset to their default state. This bit must be set high for a minimum of 100ns.

- 0 = Normal operation
- 1 = Reset and force all internal registers to their default values

Register Name: **GL.BLR**
 Register Description: **Global BERT Connect Register**
 Register Address: **03h**

Bit #	7	6	5	4	3	2	1	0
Name	-	-	-	-	-	-	-	BLC1
Default	0	0	0	0	0	0	0	0

Bit 0: BERT Connect 1 (BLC1) If this bit is set to 1, the BERT is connected to Serial Interface 1. The BERT transmitter is connected to the transmit serial port and receive to receive serial port. When the BERT is connected, normal data transfer is interrupted. Note that connecting the BERT overrides a connection to the Serial Interface, if a connection exists. When the BERT is disconnected, the connection is restored.

Register Name: **GL.RTCAL**
 Register Description: **Global Receive and Transmit Serial Port Clock Activity Latched Status**
 Register Address: **04h**

Bit #	7	6	5	4	3	2	1	0
Name	-	-	-	RLCAL1	-	-	-	TLCALS1
Default	-	-	-	-	-	-	-	-

Bit 4: Receive Serial Interface Clock Activity Latched Status 1 (RLCAL1) This bit is set to 1 if the receive clock for Serial Interface 1 has activity. This bit is cleared upon read.

Bit 0: Transmit Serial Interface Clock Activity Latched Status 1 (TSCALS1) This bit is set to 1 if the transmit clock for Serial Interface 1 has activity. This bit is cleared upon read.

Register Name: **GL.SRCALS**
 Register Description: **Global SDRAM Reference Clock Activity Latched Status**
 Register Address: **05h**

Bit #	7	6	5	4	3	2	1	0
Name	-	-	-	-	-	-	REFCLKS	SYSCLS
Default	-	-	-	-	-	-	-	-

Bit 1: Reference Clock Activity Latched Status (REFCLKS) This bit is set to 1 if REF_CLK has activity. This bit is cleared upon read.

Bit 0: System Clock Input Latched Status (SYSCLS) This bit is set to 1 if SYSCLKI has activity. This bit is cleared upon read.

Register Name: **GL.LIE**
 Register Description: **Global Serial Interface Interrupt Enable**
 Register Address: **06h**

Bit #	7	6	5	4	3	2	1	0
Name	-	-	-	LIN1TIE	-	-	-	LIN1RIE
Default	0	0	0	0	0	0	0	0

Bit 4: Serial Interface 1 TX Interrupt Enable (LINE1TIE) Setting this bit to 1 enables an interrupt on LIN1TIS

Bit 0: Serial Interface 1 RX Interrupt Enable (LINE1RIE) Setting this bit to 1 enables an interrupt on LIN1RIS

Register Name: **GL.LIS**
 Register Description: **Global Serial Interface Interrupt Status**
 Register Address: **07h**

Bit #	7	6	5	4	3	2	1	0
Name	-	-	-	LIN1TIS	-	-	-	LIN1RIS
Default	0	0	0	0	0	0	0	0

Bit 4: Serial Interface 1 TX Interrupt Status (LINE1TIS) This bit is set if Serial Interface 1 Transmit has an enabled interrupt generating event. Serial Interface interrupts consist of HDLC interrupts and X.86 interrupts.

Bit 0: Serial Interface 1 RX Interrupt Status (LINER1IS) This bit is set if Serial Interface 1 Receive has an enabled interrupt generating event. Serial Interface interrupts consist of HDLC interrupts and X.86 interrupts.

Register Name: **GL.SIE**
 Register Description: **Global Ethernet Interface Interrupt Enable**
 Register Address: **08h**

Bit #	7	6	5	4	3	2	1	0
Name	-	-	-	-	-	-	-	SUB1IE
Default	0	0	0	0	0	0	0	0

Bit 0: Ethernet Interface 1 Interrupt Enable (SUB1IE) Setting this bit to 1 enables an interrupt on SUB1S.

Register Name: **GL.SIS**
 Register Description: **Global Ethernet Interface Interrupt Status**
 Register Address: **09h**

Bit #	7	6	5	4	3	2	1	0
Name	-	-	-	-	-	-	-	SUB1IS
Default	0	0	0	0	0	0	0	0

Bit 0: Ethernet Interface 1 Interrupt Status (SUB1IS) This bit is set to 1 if Ethernet Interface 1 has an enabled interrupt generating event. The Ethernet Interface consists of the MAC and The RMII/MII port.

Register Name: **GL.TRQIE**
 Register Description: **Global Transmit Receive Queue Interrupt Enable**
 Register Address: **0Ah**

Bit #	7	6	5	4	3	2	1	0
Name	-	-	-	TQ1IE	-	-	-	RQ1IE
Default	0	0	0	0	0	0	0	0

Bit 4: Transmit Queue 1 Interrupt Enable (TQ1IE) Setting this bit to 1 enables an interrupt on TQ1IS.

Bit 0: Receive Queue 1 Interrupt Enable (RQ1IE) Setting this bit to 1 enables an interrupt on RQ1IS.

Register Name: **GL.TRQIS**
 Register Description: **Global Transmit Receive Queue Interrupt Status**
 Register Address: **0Bh**

Bit #	7	6	5	4	3	2	1	0
Name	-	-	-	TQ1IS	-	-	-	RQ1IS
Default	0	0	0	0	0	0	0	0

Bit 4: Transmit Queue 1 Interrupt Status (TQ1IS) If this bit is set to 1, the Transmit Queue 1 has interrupt status event. Transmit queue events are transmit queue crossing thresholds and queue overflows.

Bit 0: Receive Queue 1 Interrupt Status (RQ1IS) If this bit is set to 1, the Receive Queue 1 has interrupt status event. Receive queue events are transmit queue crossing thresholds and queue overflows.

Register Name: **GL.BIE**
 Register Description: **Global BERT Interrupt Enable**
 Register Address: **0Ch**

Bit #	7	6	5	4	3	2	1	0
Name	-	-	-	-	-	-	-	BIE
Default	0	0	0	0	0	0	0	0

Bit 0: BERT Interrupt Enable (BIE) Setting this bit to 1 enables an interrupt on BIS.

Register Name: **GL.BIS**
 Register Description: **Global BERT Interrupt Status**
 Register Address: **0Dh**

Bit #	7	6	5	4	3	2	1	0
Name	-	-	-	-	-	-	-	BIS
Default	0	0	0	0	0	0	0	0

Bit 0: BERT Interrupt Status (BIS) This bit is set to 1 if the BERT has an enabled interrupt generating event.

Register Name: **GL.CON1**
 Register Description: **Connection Register for Ethernet Interface 1**
 Register Address: **0Eh**

Bit #	7	6	5	4	3	2	1	0
Name	-	-	-	-	-	-	-	LINE1[0]
Default	0	0	0	0	0	0	0	1

Bit 0: LINE1[0] This bit is preserved to provide software compatibility with multiport devices. The LINE1[0] bit selects the Ethernet port that is to be connected to the Serial Interface. Note that bidirectional connection is assumed between the Serial and Ethernet Interfaces. The connection register and corresponding queue size must be defined for proper operation. Writing a 0 to this register will disconnect the connection. When a connection is disconnected, "1"s are sourced to the Serial Interface transmit and to the HDLC receiver and the clocks to the HDLC transmitter/receiver are disabled.

Register Name: **GL.C1QPR**
 Register Description: **Connection 1 Queue Pointer Reset**
 Register Address: **12h**

Bit #	7	6	5	4	3	2	1	0
Name	-	-	-	-	C1MRPR	C1HWPR	C1MHPR	C1HRPR
Default	0	0	0	0	0	0	0	0

Bit 3: MAC Read Pointer Reset (C1MRPR) Setting this bit to 1 resets the receive queue read pointer for connection 1. This queue pointer must be reset after a disconnect and before a connection. The user must clear the bit before subsequent reset operations.

Bit 2: HDLC Write Pointer Reset (C1HWPR) Setting this bit to 1 resets the receive queue write pointer for connection 1. This queue pointer must be reset after a disconnect and before a connection. The user must clear the bit before subsequent reset operations.

Bit 1: HDLC Read Pointer Reset (C1MHPR) Setting this bit to 1 resets the transmit queue read pointer for connection 1. This queue pointer must be reset after a disconnect and before a connection. The user must clear the bit before subsequent reset operations.

Bit 0: MAC Transmit Write Pointer Reset (C1HRPR) Setting this bit to 1 resets the transmit queue write pointer for connection 1. This queue pointer must be reset after a disconnect and before a connection. The user must clear the bit before subsequent reset operations.

Register Name: **GL.BISTEN**
 Register Description: **BIST Enable**
 Register Address: **20h**

Bit #	7	6	5	4	3	2	1	0
Name	-	-	-	-	-	-	-	BISTE
Default	0	0	0	0	0	0	0	0

Bit 0: BIST Enable (BISTE) If this bit is set the DS33R11 performs BIST test on the SDRAM. Normal data communication is halted while BIST enable is high. The user must reset the DS33R11 after completion of BIST test before normal dataflow can begin.

Register Name: **GL.BISTPF**
 Register Description: **BIST Pass-Fail**
 Register Address: **21h**

Bit #	7	6	5	4	3	2	1	0
Name	-	-	-	-	-	-	BISTDN	BISTPF
Default	0	0	0	0	0	0	0	0

Bit 1: BIST DONE (BISTDN) If this bit is set to 1, the DS33R11 has completed the BIST Test initiated by BISTE. The pass fail result is available in BISTPF.

Bit 0: BIST Pass-Fail (BISTPF) This bit is equal to 0 after the DS33R11 performs BIST testing on the SDRAM and the test passes. This bit is set to 1 if the test failed. This bit is valid only after the BIST test is complete and the BIST DN bit is set. If set this bit can only be cleared by resetting the DS33R11.

Register Name: **GL.SDMODE1**
 Register Description: **Global SDRAM Mode Register 1**
 Register Address: **3Ah**

Bit #	7	6	5	4	3	2	1	0
Name	-	-	-	-	WT	BL2	BL1	BL0
Default	0	0	0	0	0	0	1	1

Bit 3: Wrap Type (WT) This bit is used to configure the wrap mode.

- 0 = Sequential
- 1 = Interleave

Bits 0- 2: Burst Length 0 through 2 (BL0 – BL2) These bits are used to determine the Burst Length.

Note: This register has a nonzero default value. This should be taken into consideration when initializing the device.

Note: After changing the value of this register, the user must toggle the GL.SDMODEWS.SDMW bit to write the new values to the SDRAM.

Register Name: **GL.SDMODE2**
 Register Description: **Global SDRAM Mode Register 2**
 Register Address: **3Bh**

Bit #	7	6	5	4	3	2	1	0
Name	-	-	-	-	-	LTMOD2	LTMOD1	LTMOD0
Default	0	0	0	0	0	0	1	0

Bits 0 - 2: CAS Latency Mode (LTMOD0 - LTMOD2) These bits are used to setup CAS Latency

Note: Only CAS Latency of 2 or 3 is allowed

Note: This register has a nonzero default value. This should be taken into consideration when initializing the device.

Note: After changing the value of this register, the user must toggle the GL.SDMODEWS.SDMW bit to write the new values to the SDRAM.

Register Name: **GL.SDMODEWS**
 Register Description: **Global SDRAM Mode Register Write Status**
 Register Address: **3Ch**

Bit #	7	6	5	4	3	2	1	0
Name	-	-	-	-	-	-	-	SDMW
Default	0	0	0	0	0	0	0	0

Bit 0: SDRAM Mode Write (SDMW) Setting this bit to 1 will write the current values of the mode control and refresh time control registers to the SDRAM. The user must clear this bit and set it again for subsequent write operations.

Register Name: **GL.SDRFTC**
 Register Description: **Global SDRAM Refresh Time Control**
 Register Address: **3Dh**

Bit #	7	6	5	4	3	2	1	0
Name	SREFT7	SREFT6	SREFT5	SREFT4	SREFT3	SREFT2	SREFT1	SREFT0
Default	0	1	0	0	0	1	1	0

Bits 0 - 7: SDRAM Refresh Time Control (SREFT0 – SREFT7) These 8 bits are used to control the SDRAM refresh frequency. The refresh rate will be equal to this register value x 8 x 100MHz.

Note: This register has a nonzero default value. This should be taken into consideration when initializing the device.

Note: After changing the value of this register, the user must toggle the GL.SDMODEWS.SDMW bit to write the new values to the SDRAM.

11.3 Arbiter Registers

The Arbiter manages the transport between the Ethernet port and the Serial Interface. It is responsible for queuing and dequeuing data to an external SDRAM. The arbiter handles requests from the HDLC and MAC to transfer data to/from the SDRAM. The base address of the Arbiter register space is 0040h.

11.3.1 Arbiter Register Bit Descriptions

Register Name: **AR.RQSC1**
 Register Description: **Arbiter Receive Queue Size Connection**
 Register Address: **40h**

Bit #	7	6	5	4	3	2	1	0
Name	RQSC7	RQSC6	RQSC5	RQSC4	RQSC3	RQSC2	RQSC1	RQSC0
Default	0	0	1	1	1	1	0	1

Bits 0-7: Receive Queue Size (RQSC[0:7]) These 7 bits of the size of receive queue associated with the connection. Receive queue is for data arriving from the MAC to be sent to the WAN. The Queue address size is defined in increments of 32 x 2048 bytes. The queue size is AR.RQSC1 multiplied by 32 to determine the number of 2048 byte packets that can be stored in the queue. This queue is constructed in the external SDRAM. **Note: Queue size of 0 is not allowed and should never be set.**

Register Name: **AR.TQSC1**
 Register Description: **Arbiter Transmit Queue Size Connection 1**
 Register Address: **41h**

Bit #	7	6	5	4	3	2	1	0
Name	TQSC7	TQSC6	TQSC5	TQSC4	TQSC3	TQSC2	TQSC1	TQSC0
Default	0	0	0	0	0	0	1	1

Bits 0-7: Transmit Queue Size (TQSC[0:7]) This is size of transmit queue associated with the connection. The queue address size is defined in increments of 32 packets. The range of bytes will depend on the external SDRAM connected to the DS33R11. Transmit queue is the data queue for data arriving on the WAN that is sent to the MAC. **Note that queue size of 0 is not allowed and should never be set.**

11.4 BERT Registers

Register Name: **BCR**
 Register Description: **BERT Control Register**
 Register Address: **80h**

Bit #	7	6	5	4	3	2	1	0
Name	-	PMU	RNPL	RPIC	MPR	APRD	TNPL	TPIC
Default	0	0	0	0	0	0	0	0

Bit 7: This bit must be kept low for proper operation.

Bit 6: Performance Monitoring Update (PMU) This bit causes a performance monitoring update to be initiated. A 0 to 1 transition causes the performance monitoring registers to be updated with the latest data, and the counters reset (0 or 1). For a second performance monitoring update to be initiated, this bit must be set to 0, and back to 1. If PMU goes low before the PMS bit goes high, an update might not be performed.

Bit 5: Receive New Pattern Load (RNPL) A zero to one transition of this bit will cause the programmed test pattern (QRSS, PTS, PLF [4:0], PTF [4:0], and BSP [31:0]) to be loaded in to the receive pattern generator. This bit must be changed to zero and back to one for another pattern to be loaded. Loading a new pattern will force the receive pattern generator out of the “Sync” state which causes a resynchronization to be initiated. Note: QRSS, PTS, PLF [4:0], PTF [4:0], and BSP [31:0] must not change from the time this bit transitions from 0 to 1 until four RCLKI clock cycles after this bit transitions from 0 to 1.

Bit 4: Receive Pattern Inversion Control (RPIC) When 0, the receive incoming data stream is not altered. When 1, the receive incoming data stream is inverted.

Bit 3: Manual Pattern Resynchronization (MPR) A zero to one transition of this bit will cause the receive pattern generator to resynchronize to the incoming pattern. This bit must be changed to zero and back to one for another resynchronization to be initiated. Note: A manual resynchronization forces the receive pattern generator out of the “Sync” state.

Bit 2: Automatic Pattern Resynchronization Disable (APRD) When 0, the receive pattern generator will automatically resynchronize to the incoming pattern if six or more times during the current 64-bit window the incoming data stream bit and the receive pattern generator output bit did not match. When 1, the receive pattern generator will not automatically resynchronize to the incoming pattern. Note: Automatic synchronization is prevented by not allowing the receive pattern generator to automatically exit the “Sync” state.

Bit 1: Transmit New Pattern Load (TNPL) A zero to one transition of this bit will cause the programmed test pattern (QRSS, PTS, PLF[4:0], PTF[4:0], and BSP[31:0]) to be loaded in to the transmit pattern generator. This bit must be changed to zero and back to one for another pattern to be loaded. Note: QRSS, PTS, PLF[4:0], PTF[4:0], and BSP[31:0] must not change from the time this bit transitions from 0 to 1 until four TCLKE clock cycles after this bit transitions from 0 to 1.

Bit 0: Transmit Pattern Inversion Control (TPIC) When 0, the transmit outgoing data stream is not altered. When 1, the transmit outgoing data stream is inverted.

Register Name: **BPCLR**
 Register Description: **BERT Pattern Configuration Low Register**
 Register Address: **82h**

Bit #	7	6	5	4	3	2	1	0
Name	-	QRSS	PTS	PLF4	PLF3	PLF2	PLF1	PLF0
Default	0	0	0	0	0	0	0	0

Bit 6: QRSS Enable (QRSS) When 0, the pattern generator configuration is controlled by PTS, PLF[0:4], and PTF[0:4], and BSP[0:31]. When 1, the pattern generator configuration is forced to a QRSS pattern with a generating polynomial of $x^{20} + x^{17} + 1$. The output of the pattern generator is forced to one if the next fourteen output bits are all zero.

Bit 5: Pattern Type Select (PTS) When 0, the pattern is a PRBS pattern. When 1, the pattern is a repetitive pattern.

Register Name: **BPCHR**
 Register Description: **BERT Pattern Configuration High Register**
 Register Address: **83h**

Bit #	7	6	5	4	3	2	1	0
Name	-	-	-	PTF4	PTF3	PTF2	PTF1	PTF0
Default	0	0	0	0	0	0	0	0

Bits 4 to 0: Pattern Tap Feedback (PTF[4:0]) These five bits control the PRBS “tap” feedback of the pattern generator. The “tap” feedback is from bit y of the pattern generator ($y = \text{PTF}[4:0] + 1$). These bits are ignored when programmed for a repetitive pattern. For a PRBS signal, the feedback is an XOR of bit n and bit y . The values possible are outlined in Section [9.16](#).

Register Name: **BSPB0R**
 Register Description: **BERT Pattern Byte0 Register**
 Register Address: **84h**

Bit #	7	6	5	4	3	2	1	0
Name	BSP7	BSP6	BSP5	BSP4	BSP3	BSP2	BSP1	BSP0
Default	0	0	0	0	0	0	0	0

Bits 0 to 7: BERT Pattern (BSP[7:0]) Lower eight bits of 32 bits. Register description follows next register.

Register Name: **BSPB1R**
 Register Description: **BERT Pattern Byte 1 Register**
 Register Address: **85h**

Bit #	7	6	5	4	3	2	1	0
Name	BSP15	BSP14	BSP13	BSP12	BSP11	BSP10	BSP9	BSP8
Default	0	0	0	0	0	0	0	0

Bits 0 to 7: BERT Pattern (BSP[15:8]) 8 bits of 32 bits. Register description below.

Register Name: **BSPB2R**
 Register Description: **BERT Pattern Byte2 Register**
 Register Address: **86h**

Bit #	7	6	5	4	3	2	1	0
Name	BSP23	BSP22	BSP21	BSP20	BSP19	BSP18	BSP17	BSP16
Default	0	0	0	0	0	0	0	0

Bits 0 to 7: BERT Pattern (BSP[23:16]) 8 bits of 32 bits. Register description below.

Register Name: **BSPB3R**
 Register Description: **BERT Seed/Pattern Byte3 Register**
 Register Address: **87h**

Bit #	7	6	5	4	3	2	1	0
Name	BSP31	BSP30	BSP29	BSP28	BSP27	BSP26	BSP25	BSP24
Default	0	0	0	0	0	0	0	0

Bits 0 to 8: BERT Pattern (BSP[31:24]) Upper 8 bits of 32 bits. Register description below.

BERT Pattern (BSP[31:0]) These 32 bits are the programmable seed for a transmit PRBS pattern, or the programmable pattern for a transmit or receive repetitive pattern. BSP(31) is the first bit output on the transmit side for a 32-bit repetitive pattern or 32-bit length PRBS. BSP(31) is the first bit input on the receive side for a 32-bit repetitive pattern.

Register Name: **TEICR**
 Register Description: **Transmit Error Insertion Control Register**
 Register Address: **88h**

Bit #	7	6	5	4	3	2	1	0
Name	-	-	TIER2	TIER1	TIER0	BEI	TSEI	-
Default	0	0	0	0	0	0	0	0

Bits 3 to 5: Transmit Error Insertion Rate (TEIR[2:0]) These three bits indicate the rate at which errors are inserted in the output data stream. One out of every 10^n bits is inverted. TEIR[2:0] is the value n. A TEIR[2:0] value of 0 disables error insertion at a specific rate. A TEIR[2:0] value of 1 result in every 10^{th} bit being inverted. A TEIR[2:0] value of 2 results in every 100^{th} bit being inverted. Error insertion starts when this register is written to with a TEIR[2:0] value that is nonzero. If this register is written to during the middle of an error insertion process, the new error rate is started after the next error is inserted.

Bit 2: Bit Error Insertion Enable (BEI) When 0, single bit error insertion is disabled. When 1, single bit error insertion is enabled.

Bit 1: Transmit Single Error Insert (TSEI) This bit causes a bit error to be inserted in the transmit data stream if and single bit error insertion is enabled. A 0 to 1 transition causes a single bit error to be inserted. For a second bit error to be inserted, this bit must be set to 0, and back to 1. Note: If this bit transitions more than once between error insertion opportunities, only one error is inserted.

All other bits in this register besides BEI and TSEI and TIER must be reset to 0 for proper operation.

Register Name: **BSR**
 Register Description: **BERT Status Register**
 Register Address: **8Ch**

Bit #	7	6	5	4	3	2	1	0
Name	-	-	-	-	PMS	-	<u>BEC</u>	<u>OOS</u>
Default	0	0	0	0	0	0	0	0

Bit 3: Performance Monitoring Update Status (PMS) This bit indicates the status of the receive performance monitoring register (counters) update. This bit will transition from low to high when the update is completed. PMS is asynchronously forced low when the PMU bit goes low. TCLKE and RCLKI must be present.

Bit 1: Bit Error Count (BEC) When 0, the bit error count is zero. When 1, the bit error count is one or more.

Bit 0: Out Of Synchronization (OOS) When 0, the receive pattern generator is synchronized to the incoming pattern. When 1, the receive pattern generator is not synchronized to the incoming pattern.

Register Name: **BSRL**
 Register Description: **BERT Status Register Latched**
 Register Address: **8Eh**

Bit #	7	6	5	4	3	2	1	0
Name	-	-	-	-	PMSL	<u>BEL</u>	<u>BECL</u>	<u>OOSL</u>
Default	-	-	-	-	-	-	-	-

Bit 3: Performance Monitor Update Status Latched (PMSL) This bit is set when the PMS bit transitions from 0 to 1.

Bit 2: Bit Error Detected Latched (BEL) This bit is set when a bit error is detected.

Bit 1: Bit Error Count Latched (BECL) This bit is set when the BEC bit transitions from 0 to 1.

Bit 0: Out Of Synchronization Latched (OOSL) This bit is set when the OOS bit changes state.

Register Name: **BSRIE**
 Register Description: **BERT Status Register Interrupt Enable**
 Register Address: **90h**

Bit #	7	6	5	4	3	2	1	0
Name	-	-	-	-	PMSIE	BEIE	BECIE	OOSIE
Default	0	0	0	0	0	0	0	0

Bit 3: Performance Monitoring Update Status Interrupt Enable (PMSIE) This bit enables an interrupt if the PMSL bit is set.

0 = interrupt disabled
 1 = interrupt enabled

Bit 2: Bit Error Interrupt Enable (BEIE) This bit enables an interrupt if the BEL bit is set.

0 = interrupt disabled
 1 = interrupt enabled

Bit 1: Bit Error Count Interrupt Enable (BECIE) This bit enables an interrupt if the BECL bit is set.

0 = interrupt disabled
 1 = interrupt enabled

Bit 0: Out Of Synchronization Interrupt Enable (OOSIE) This bit enables an interrupt if the OOSL bit is set.

0 = interrupt disabled
 1 = interrupt enabled

Register Name: **RBECB0R**
 Register Description: **Receive Bit Error Count Byte 0 Register**
 Register Address: **94h**

Bit #	7	6	5	4	3	2	1	0
Name	<u>BEC7</u>	<u>BEC6</u>	<u>BEC5</u>	<u>BEC4</u>	<u>BEC3</u>	<u>BEC2</u>	<u>BEC1</u>	<u>BEC0</u>
Default	0	0	0	0	0	0	0	0

Bits 0 - 7: Bit Error Count (BEC[0:7]) Lower eight bits of 24 bits. Register description below.

Register Name: **RBECB1R**
 Register Description: **Receive Bit Error Count Byte 1 Register**
 Register Address: **95h**

Bit #	7	6	5	4	3	2	1	0
Name	<u>BEC15</u>	<u>BEC14</u>	<u>BEC13</u>	<u>BEC12</u>	<u>BEC11</u>	<u>BEC10</u>	<u>BEC9</u>	<u>BEC8</u>
Default	0	0	0	0	0	0	0	0

Bits 0 - 7: Bit Error Count (BEC[8:15]) Eight bits of a 24 bit value. Register description below.

Register Name: **RBECR2**
 Register Description: **Receive Bit Error Count Byte 2 Register**
 Register Address: **96h**

Bit #	7	6	5	4	3	2	1	0
Name	<u>BEC23</u>	<u>BEC22</u>	<u>BEC21</u>	<u>BEC20</u>	<u>BEC19</u>	<u>BEC18</u>	<u>BEC17</u>	<u>BEC16</u>
Default	0	0	0	0	0	0	0	0

Bits 0 - 7: Bit Error Count (BEC[16:23]) Upper 8-bits of the register.

Bit Error Count (BEC[0:23]) These twenty-four bits indicate the number of bit errors detected in the incoming data stream. This count stops incrementing when it reaches a count of FF FFFFh. The associated bit error counter will not be incremented when an OOS condition exists.

Register Name: **RBCB0**
 Register Description: **Receive Bit Count Byte 0 Register**
 Register Address: **98h**

Bit #	7	6	5	4	3	2	1	0
Name	<u>BC7</u>	<u>BC6</u>	<u>BC5</u>	<u>BC4</u>	<u>BC3</u>	<u>BC2</u>	<u>BC1</u>	<u>BC0</u>
Default	0	0	0	0	0	0	0	0

Bits 0 - 7: Bit Count (BC[0:7]) Eight bits of a 32 bit value. Register description below.

Register Name: **RBCB1**
 Register Description: **Receive Bit Count Byte 1 Register #1**
 Register Address: **99h**

Bit #	7	6	5	4	3	2	1	0
Name	<u>BC15</u>	<u>BC14</u>	<u>BC13</u>	<u>BC12</u>	<u>BC11</u>	<u>BC10</u>	<u>BC9</u>	<u>BC8</u>
Default	0	0	0	0	0	0	0	0

Bits 0 - 7: Bit Count (BC[8:15]) Eight bits of a 32 bit value. Register description below.

Register Name: **RBCB2**
 Register Description: **Receive Bit Count Byte 2 Register**
 Register Address: **9Ah**

Bit #	7	6	5	4	3	2	1	0
Name	<u>BC23</u>	<u>BC22</u>	<u>BC21</u>	<u>BC20</u>	<u>BC19</u>	<u>BC18</u>	<u>BC17</u>	<u>BC16</u>
Default	0	0	0	0	0	0	0	0

Bits 0 - 7: Bit Count (BC[16:23]) Eight bits of a 32 bit value. Register description below.

Register Name: **RBCB3**
 Register Description: **Receive Bit Count Byte 3 Register**
 Register Address: **9Bh**

Bit #	7	6	5	4	3	2	1	0
Name	<u>BC31</u>	<u>BC30</u>	<u>BC29</u>	<u>BC28</u>	<u>BC27</u>	<u>BC26</u>	<u>BC25</u>	<u>BC24</u>
Default	0	0	0	0	0	0	0	0

Bits 0 - 7: Bit Count (BC[24:31]) Upper 8-bits of the register.

Bit Count (BC[0:31]) These thirty-two bits indicate the number of bits in the incoming data stream. This count stops incrementing when it reaches a count of FFFF FFFFh. The associated bit counter will not be incremented when an OOS condition exists.

11.5 Serial Interface Registers

The Serial Interface contains the Serial HDLC transport circuitry and the associated serial port. The Serial Interface register map consists of registers that are common functions, transmit functions, and receive functions.

Bits that are underlined are read-only; all other bits can be written. All reserved registers and bits with “-“ designation should be written to zero, unless specifically noted in the register definition. When read, the information from reserved registers and bits designated with “-“ should be discarded.

Counter registers are updated by asserting (low to high transition) the associated performance monitoring update signal (xxPMU). During the counter register update process, the associated performance monitoring status signal (xxPMS) is deasserted. The counter register update process consists of loading the counter register with the current count, resetting the counter, forcing the zero count status indication low for one clock cycle, and then asserting xxPMS. No events are missed during this update procedure.

A latched bit is set when the associated event occurs, and remains set until it is cleared by reading. Once cleared, a latched bit will not be set again until the associated event occurs again. Reserved configuration bits and registers should be written to zero.

11.5.1 Serial Interface Transmit and Common Registers

Serial Interface Transmit Registers are used to control the HDLC transmitter associated with each Serial Interface. The register map is shown in the following Table. Note that throughout this document the HDLC Processor is also referred to as a “packet processor”.

11.5.1.1 Serial Interface Transmit Register Bit Descriptions

Register Name: **LI.TSLCR**
 Register Description: **Transmit Serial Interface Configuration Register**
 Register Address: **0C0h**

Bit #	7	6	5	4	3	2	1	0
Name	-	-	-	-	-	-	-	TDENPLT
Default	0	0	0	0	0	0	0	0

Bit 0: Transmit Data Enable Polarity (TDENPLT) If set to 1, TDEN is active low for enable. In the default mode, when TDEN is logic high, the data is enabled and output by the DS33R11.

Register Name: **LI.RSTPD**
 Register Description: **Serial Interface Reset Register**
 Register Address: **0C1h**

Bit #	7	6	5	4	3	2	1	0
Name	-	-	-	-	-	-	RESET	-
Default	0	0	0	0	0	0	0	0

Bit 1: RESET If this bit set to 1, the Data Path and Control and Status for this interface are reset. The Serial Interface is held in Reset as long as this bit is high. This bit must be high for a minimum of 200ns for a valid reset to occur.

Register Name: **LI.LPBK**
 Register Description: **Serial Interface Loopback Control Register**
 Register Address: **0C2h**

Bit #	7	6	5	4	3	2	1	0
Name	-	-	-	-	-	-	-	QLP
Default	0	0	0	0	0	0	0	0

Bit 0: Queue Loopback Enable (QLP) If this bit set to 1, data received on the Serial Interface is looped back to the Serial Interface transmitter. Received data will not be sent from the Serial Interface to the Ethernet Interface. Buffered packet data will remain in queue until the loopback is removed.

11.5.1.2 Transmit HDLC Processor Register Bit Descriptions

Register Name: **LI.TPPCL**
 Register Description: **Transmit Packet Processor Control Low Register**
 Register Address: **0C4h**

Bit #	7	6	5	4	3	2	1	0
Name	-	-	TFAD	TF16	TIFV	TSD	TBRE	TIAEI
Default	0	0	0	0	0	0	0	0

Note: The user should take care not to modify this register value during packet error insertion.

Bits 5 - 6: Transmit FCS Append Disable (TFAD) – This bit controls whether or not an FCS is appended to the end of each packet. When equal to 0, the calculated FCS bytes are appended to packets. When set to 1, packets are transmitted without FCS. In X.86 Mode, FCS is always 32 bits and is always appended to the packet.

Bit 4: Transmit FCS-16 Enable (TF16) – When 0, the FCS processing uses a 32-bit FCS. When 1, the FCS processing uses a 16-bit FCS. In X.86 Mode, 32-bit FCS processing is always enabled, regardless of this bit.

Bit 3: Transmit Bit Synchronous Inter-frame Fill Value (TIFV) – When 0, inter-frame fill is done with the flag sequence (7Eh). When 1, inter-frame fill is done with all '1's (FFh). This bit is ignored in X.86 mode and the interframe flag is always 7E.

Bit 2: Transmit Scrambling Disable (TSD) – When equal to 0, $X^{43}+1$ scrambling is performed. When set to 1, scrambling is disabled.

Bit 1: Transmit Bit Reordering Enable (TBRE) – When equal to 0, bit reordering is disabled (The first bit transmitted is from the MSB of the transmit FIFO byte TFD [7]). When set to 1, bit reordering is enabled (The first bit transmitted is from the LSB of the transmit FIFO byte TFD [0]).

Bit 0: Transmit Initiate Automatic Error Insertion (TIAEI) – This write-only bit initiates error insertion. See the LI.TEPHC register definition for details of usage.

Register Name: **LI.TIFGC**
 Register Description: **Transmit Inter-Frame Gapping Control Register**
 Register Address: **0C5h**

Bit #	7	6	5	4	3	2	1	0
Name	TIFG7	TIFG6	TIFG5	TIFG4	TIFG3	TIFG2	TIFG1	TIFG0
Default	0	0	0	0	0	0	0	1

Bits 0 - 7: Transmit Inter-Frame Gapping (TIFG[7:0]) – These eight bits indicate the number of additional flags and bytes of inter-frame fill to be inserted between packets. The number of flags and bytes of inter-frame fill between packets is at least the value of TIFG[7:0] plus 1. Note: If inter-frame fill is set to all 1's, a TIFG value of 2 or 3 will result in a flag, two bytes of 1's, and an additional flag between packets.

Register Name: **LI.TEPLC**
 Register Description: **Transmit Errored Packet Low Control Register**
 Register Address: **0C6h**

Bit #	7	6	5	4	3	2	1	0
Name	TPEN7	TPEN6	TPEN5	TPEN4	TPEN3	TPEN2	TPEN1	TPEN0
Default	0	0	0	0	0	0	0	0

Bits 0 – 7: Transmit Errored Packet Insertion Number (TPEN[7:0]) – These eight bits indicate the total number of errored packets to be transmitted when triggered by TIAEI. Error insertion will end after this number of errored packets have been transmitted. A value of FFh results in continuous errored packet insertion at the specified rate.

Register Name: **LI.TEPHC**
 Register Description: **Transmit Errored Packet High Control Register**
 Register Address: **0C7h**

Bit #	7	6	5	4	3	2	1	0
Name	MEIMS	TPER6	TPER5	TPER4	TPER3	TPER2	TPER1	TPER0
Default	0	0	0	0	0	0	0	0

Bit 7: Manual Error Insert Mode Select (MEIMS) – When 0, the transmit manual error insertion signal (TMEI) will not cause errors to be inserted. When 1, TMEI will cause an error to be inserted when it transitions from a 0 to a 1. Note: Enabling TMEI does not disable error insertion using TCER[6:0] and TCEN[7:0].

Bits 0 – 6: Transmit Errored Packet Insertion Rate (TPER[6:0]) – These seven bits indicate the rate at which errored packets are to be output. One out of every $x * 10^y$ packets is to be an errored packet. TPER[3:0] is the value x, and TPER[6:4] is the value y which has a maximum value of 6. If TPER[3:0] has a value of 0h errored packet insertion is disabled. If TPER[6:4] has a value of 6xh or 7xh the errored packet rate is $x * 10^6$. A TPER[6:0] value of 01h results in every packet being errored. A TPER[6:0] value of 0Fh results in every 15th packet being errored. A TPER[6:0] value of 11h results in every 10th packet being errored.

To initiate automatic error insertion, use the following routine:

- 1) Configure LI.TEPLC and LI.TEPHC for the desired error insertion mode.
- 2) Write the LI.TPPCL.TIAEI bit to 1. Note that this bit is write-only.
- 3) If not using continuous error insertion (LI.TPELC is not equal to FFh), the user should monitor the LI.TPPSR.TEPF bit for completion of the error insertion. If interrupt on completion of error insertion is enabled (LI.TPPSR.TEPFIE = 1), the user only needs to wait for the interrupt condition.
- 4) Proceed with the cleanup routine listed below.

Cleanup routine:

- 1) Write LI.TEPLC and LI.TEPHC each to 00h.
- 2) Write the LI.TPPCL.TIAEI bit to 0.

Register Name: **LI.TPPSR**
 Register Description: **Transmit Packet Processor Status Register**
 Register Address: **0C8h**

Bit #	7	6	5	4	3	2	1	0
Name	-	-	-	-	-	-	-	<u>TEPF</u>
Default	0	0	0	0	0	0	0	0

Bit 0: Transmit Errored Packet Insertion Finished (TEPF) – This bit is set when the number of errored packets indicated by the TPEN[7:0] bits in the TEPC register have been transmitted. This bit is cleared when errored packet insertion is disabled, or a new errored packet insertion process is initiated.

Register Name: **LI.TPPSRL**
 Register Description: **Transmit Packet Processor Status Register Latched**
 Register Address: **0C9h**

Bit #	7	6	5	4	3	2	1	0
Name	-	-	-	-	-	-	-	<u>TEPFL</u>
Default	-	-	-	-	-	-	-	-

Bit 0: Transmit Errored Packet Insertion Finished Latched (TEPFL) – This bit is set when the TEPF bit in the TPPSR register transitions from zero to one.

Register Name: **LI.TPPSRIE**
 Register Description: **Transmit Packet Processor Status Register Interrupt Enable**
 Register Address: **0CAh**

Bit #	7	6	5	4	3	2	1	0
Name	-	-	-	-	-	-	-	TEPFIE
Default	0	0	0	0	0	0	0	0

Bit 0: Transmit Errored Packet Insertion Finished Interrupt Enable (TEPFIE) – This bit enables an interrupt if the TEPFL bit in the LI.TPPSRL register is set.

0 = interrupt disabled

1 = interrupt enabled

Register Name: **LI.TPCR0**
 Register Description: **Transmit Packet Count Byte 0**
 Register Address: **0CCh**

Bit #	7	6	5	4	3	2	1	0
Name	<u>TPC7</u>	<u>TPC6</u>	<u>TPC5</u>	<u>TPC4</u>	<u>TPC3</u>	<u>TPC2</u>	<u>TPC1</u>	<u>TPC0</u>
Default	0	0	0	0	0	0	0	0

Bits 0 – 7: Transmit Packet Count (TPC[7:0]) – Eight bits of 24 bit value. Register description below.

Register Name: **LI.TPCR1**
 Register Description: **Transmit Packet Count Byte 1**
 Register Address: **0CDh**

Bit #	7	6	5	4	3	2	1	0
Name	<u>TPC15</u>	<u>TPC14</u>	<u>TPC13</u>	<u>TPC12</u>	<u>TPC11</u>	<u>TPC10</u>	<u>TPC9</u>	<u>TPC8</u>
Default	0	0	0	0	0	0	0	0

Bits 0 – 7: Transmit Packet Count (TPC[15:8]) – Eight bits of 24 bit value. Register description below.

Register Name: **LI.TPCR2**
 Register Description: **Transmit Packet Count Byte 2**
 Register Address: **0CEh**

Bit #	7	6	5	4	3	2	1	0
Name	<u>TPC23</u>	<u>TPC22</u>	<u>TPC21</u>	<u>TPC20</u>	<u>TPC19</u>	<u>TPC18</u>	<u>TPC17</u>	<u>TPC16</u>
Default	0	0	0	0	0	0	0	0

Bits 0 – 7: Transmit Packet Count (TPC[23:16]) – These twenty-four bits indicate the number of packets extracted from the Transmit FIFO and output in the outgoing data stream.

Register Name: **LI.TBCR0**
 Register Description: **Transmit Byte Count Byte 0**
 Register Address: **0D0h**

Bit #	7	6	5	4	3	2	1	0
Name	<u>TBC7</u>	<u>TBC6</u>	<u>TBC5</u>	<u>TBC4</u>	<u>TBC3</u>	<u>TBC2</u>	<u>TBC1</u>	<u>TBC0</u>
Default	0	0	0	0	0	0	0	0

Bits 0 – 7: Transmit Byte Count (TBC[0:7]) – Eight bits of 32 bit value. Register description below.

Register Name: **LI.TBCR1**
 Register Description: **Transmit Byte Count Byte 1**
 Register Address: **0D1h**

Bit #	7	6	5	4	3	2	1	0
Name	<u>TBC15</u>	<u>TBC14</u>	<u>TBC13</u>	<u>TBC12</u>	<u>TBC11</u>	<u>TBC10</u>	<u>TBC9</u>	<u>TBC8</u>
Default	0	0	0	0	0	0	0	0

Bits 0 – 7: Transmit Byte Count (TBC[15:8]) - Eight bits of 32 bit value. Register description below.

Register Name: **LI.TBCR2**
 Register Description: **Transmit Byte Count Byte 2**
 Register Address: **0D2h**

Bit #	7	6	5	4	3	2	1	0
Name	<u>TBC23</u>	<u>TBC22</u>	<u>TBC21</u>	<u>TBC20</u>	<u>TBC19</u>	<u>TBC18</u>	<u>TBC17</u>	<u>TBC16</u>
Default	0	0	0	0	0	0	0	0

Bits 0 – 7: Transmit Byte Count (TBC[23:16]) - Eight bits of 32 bit value. Register description below.

Register Name: **LI.TBCR3**
 Register Description: **Transmit Byte Count Byte 3**
 Register Address: **0D3h**

Bit #	7	6	5	4	3	2	1	0
Name	<u>TBC31</u>	<u>TBC30</u>	<u>TBC29</u>	<u>TBC28</u>	<u>TBC27</u>	<u>TBC26</u>	<u>TBC25</u>	<u>TBC24</u>
Default	0	0	0	0	0	0	0	0

Bits 0 – 7: Transmit Byte Count (TBC[31:24]) – These thirty-two bits indicate the number of packet bytes inserted in the outgoing data stream.

Register Name: **LI.TMEI**
 Register Description: **Transmit Manual Error Insertion**
 Register Address: **0D4h**

Bit #	7	6	5	4	3	2	1	0
Name	-	-	-	-	-	-	-	TMEI
Default	0	0	0	0	0	0	0	0

Bit 0: Transmit Manual Error Insertion (TMEI) A zero to one transition will insert a single error in the Transmit direction.

Register Name: **LI.THPMUU**
 Register Description: **Serial Interface Transmit HDLC PMU Update Register**
 Register Address: **0D6h**

Bit #	7	6	5	4	3	2	1	0
Name	-	-	-	-	-	-	-	TPMUU
Default	0	0	0	0	0	0	0	0

Bit 0: Transmit PMU Update (TPMUU) This signal causes the transmit cell/packet processor block performance monitoring registers (counters) to be updated. A 0 to 1 transition causes the performance monitoring registers to be updated with the latest data, and the counters reset (0 or 1). This update updates performance monitoring counters for the Serial Interface.

Register Name: **LI.THPMUS**
 Register Description: **Serial Interface Transmit HDLC PMU Update Status Register**
 Register Address: **0D7h**

Bit #	7	6	5	4	3	2	1	0
Name	-	-	-	-	-	-	-	TPMUS
Default	0	0	0	0	0	0	0	0

Bit 0: Transmit PMU Update Status (TPMUS) This bit is set when the Transmit PMU Update is completed. This bit is cleared when TPMUU is reset.

11.5.2 X.86 Registers

X.86 transmit and common registers are used to control the operation of the X.86 encoder and decoder.

Register Name: **LI.TX86EDE**
 Register Description: **X.86 Encoding Decoding Enable**
 Register Address: **0D8h**

Bit #	7	6	5	4	3	2	1	0
Name	-	-	-	-	-	-	-	X86ED
Default	0	0	0	0	0	0	0	0

Bit 0: X.86 Encoding Decoding (X86ED) If this bit is set to 1, X.86 encoding and decoding is enabled for the Transmit and Receive paths. The MAC Frame is encapsulated in the X.86 Frame for Transmit and the X.86 headers are checked for in the received data. If X.86 functionality is selected, the X.86 receiver byte boundary is provided by the RBSYNC signal and the DS33R11 provides the transmit byte synchronization TBSYNC. No HDLC encapsulation is performed.

Register Name: **LI.TRX86A**
 Register Description: **Transmit Receive X.86 Address**
 Register Address: **0D9h**

Bit #	7	6	5	4	3	2	1	0
Name	X86TRA7	X86TRA6	X86TRA5	X86TRA4	X86TRA3	X86TRA2	X86TRA1	X86TRA0
Default	0	0	0	0	0	1	0	0

Bits 0 - 7: X86 Transmit Receive Address (X86TRA0-7) This is the address field for the X.86 transmitter and for the receiver. The register default value is 0x04.

Register Name: **LI.TRX8C**
 Register Description: **Transmit Receive X.86 Control**
 Register Address: **0DAh**

Bit #	7	6	5	4	3	2	1	0
Name	X86TRC7	X86TRC6	X86TRC5	X86TRC4	X86TRC3	X86TRC2	X86TRC1	X86TRC0
Default	0	0	0	0	0	0	1	1

Bits 0 - 7: X86 Transmit Receive Control (X86TRC0-7) This is the control field for the X.86 transmitter and expected value for the receiver. The register is reset to 0x03

Register Name: **LI.TRX86SAPIH**
 Register Description: **Transmit Receive X.86 SAPIH**
 Register Address: **0DBh**

Bit #	7	6	5	4	3	2	1	0
Name	TRSAPIH7	TRSAPIH6	TRSAPIH5	TRSAPIH4	TRSAPIH3	TRSAPIH2	TRSAPIH1	TRSAPIH0
Default	1	1	1	1	1	1	1	0

Bits 0 - 7: X86 Transmit Receive Address (TRSAPIH0-7) This is the address field for the X.86 transmitter and expected for the receiver. The register is reset to 0xfe.

Register Name: **LI.TRX86SAPIL**
 Register Description: **Transmit Receive X.86 SAPIL**
 Register Address: **0DCh**

Bit #	7	6	5	4	3	2	1	0
Name	TRSAPIL7	TRSAPIL6	TRSAPIL5	TRSAPIL4	TRSAPIL3	TRSAPIL2	TRSAPIL1	TRSAPIL0
Default	0	0	0	0	0	0	0	1

Bits 0 – 7: X86 Transmit Receive Control (TRSAPIL0-7) This is the address field for the X.86 transmitter and expected value for the receiver. The register is reset to 0x01

Register Name: **LI.CIR**
 Register Description: **Committed Information Rate**
 Register Address: **0DDh**

Bit #	7	6	5	4	3	2	1	0
Name	CIRE	CIR6	CIR5	CIR4	CIR3	CIR2	CIR1	CIR0
Default	0	0	0	0	0	0	0	1

Bit 7: Committed Information Rate Enable (CIRE) Set this bit to 1 to enable the Committed Information Rate Controller feature.

Bits 0 – 6: Committed Information Rate (CIR0-6) These bits provide the value for the committed information rate. The value is multiplied by 500kbit/s to get the CIR value. The user must ensure that the CIR value is less than or equal to the maximum Serial Interface transmit rate. The valid range is from 1 to 104. Any values outside this range will result in unpredictable behavior. Note that a value of 104 translates to a 52Mbit/s line rate. Hence if the CIR is above the line rate, the rate is not restricted by the CIR. For instance - if using a T1 line and the CIR is programmed with a value of 104, it has no effect in restricting the rate.

11.5.3 Receive Serial Interface

Serial Receive Registers are used to control the HDLC Receiver associated with each Serial Interface. Note that throughout this document HDLC Processor is also referred to as “Packet Processor”. The receive packet processor block has seventeen registers.

11.5.3.1 Receive Serial Register Bit Descriptions

Register Name: **LI.RSLCR**
 Register Description: **Receive Serial Interface Configuration Register**
 Register Address: **100h**

Bit #	7	6	5	4	3	2	1	0
Name	-	-	-	-	-	-	-	RDENPLT
Default	0	0	0	0	0	0	0	0

Bit 0: Receive Data Enable Polarity (RDENPLT) Receive Data Enable Polarity. If set to 1, RDEN Low enables reception of the bit.

Register Name: **LI.RPPCL**
 Register Description: **Receive Packet Processor Control Low Register**
 Register Address: **101h**

Bit #	7	6	5	4	3	2	1	0
Name	-	-	RFPD	RF16	RFED	RDD	RBRE	RCCE
Default	0	0	0	0	0	0	0	0

Bit 5: Receive FCS Processing Disable (RFPD) – When equal to 0, FCS processing is performed and FCS is appended to packets. When set to 1, FCS processing is disabled (the packets do not have an FCS appended). In X.86 mode, FCS processing is always enabled.

Bit 4: Receive FCS-16 Enable (RF16) – When 0, the error checking circuit uses a 32-bit FCS. When 1, the error checking circuit uses a 16-bit FCS. This bit is ignored when FCS processing is disabled. In X.86 mode, the FCS is always 32 bits.

Bit 3: Receive FCS Extraction Disable (RFED) – When 0, the FCS bytes are discarded. When 1, the FCS bytes are passed on. This bit is ignored when FCS processing is disabled. In X.86 mode, FCS bytes are discarded.

Bit 2: Receive Descrambling Disable (RDD) – When equal to 0, $X^{43}+1$ descrambling is performed. When set to 1, descrambling is disabled.

Bit 1: Receive Bit Reordering Enable (RBRE) – When equal to 0, reordering is disabled and the first bit received is expected to be the MSB DT [7] of the byte. When set to 1, bit reordering is enabled and the first bit received is expected to be the LSB DT [0] of the byte.

Bit 0: Receive Clear Channel Enable (RCCE) – When equal to 0, packet processing is enabled. When set to 1, the device is in clear channel mode and all packet-processing functions except descrambling and bit reordering are disabled.

Register Name: **LI.RMPSC_L**
 Register Description: **Receive Maximum Packet Size Control Low Register**
 Register Address: **102h**

Bit #	7	6	5	4	3	2	1	0
Name	RMX7	RMX6	RMX5	RMX4	RMX3	RMX2	RMX1	RMX0
Default	1	1	1	0	0	0	0	0

Bits 0 - 7: Receive Maximum Packet Size (RMX[7:0]) Eight bits of a sixteen bit value. Register description below.

Register Name: **LI.RMPSC_H**
 Register Description: **Receive Maximum Packet Size Control High Register**
 Register Address: **103h**

Bit #	7	6	5	4	3	2	1	0
Name	RMX15	RMX14	RMX13	RMX12	RMX11	RMX10	RMX9	RMX8
Default	0	0	0	0	0	1	1	1

Bits 0-7: Receive Maximum Packet Size (RMX[8:15]) These sixteen bits indicate the maximum allowable packet size in bytes. The size includes the FCS bytes, but excludes bit/byte stuffing. Note: If the maximum packet size is less than the minimum packet size, all packets are discarded. When packet processing is disabled, these sixteen bits indicate the "packet" size the incoming data is to be broken into.

The maximum packet size allowable is 2016 bytes plus the FCS bytes. Any values programmed that are greater than 2016 + FCS will have the same effect as 2016+ FCS value.

In X.86 mode, the X.86 encapsulation bytes are included in maximum size control.

Register Name: **LI.RPPSR**
 Register Description: **Receive Packet Processor Status Register**
 Register Address: **104h**

Bit #	7	6	5	4	3	2	1	0
Name	-	-	-	-	-	REPC	RAPC	RSPC
Default	0	0	0	0	0	0	0	0

Bit 2: Receive FCS Errored Packet Count (REPC) This read only bit indicates that the receive FCS errored packet count is nonzero.

Bit 1: Receive Aborted Packet Count (RAPC) This read only bit indicates that the receive aborted packet count is nonzero.

Bit 0: Receive Size Violation Packet Count (RSPC) This read only bit indicates that the receive size violation packet count is nonzero.

Register Name: **LI.RPPSRL**
 Register Description: **Receive Packet Processor Status Register Latched**
 Register Address: **105h**

Bit #	7	6	5	4	3	2	1	0
Name	<u>REPL</u>	<u>RAPL</u>	<u>RIPDL</u>	<u>RSPDL</u>	<u>RLPDL</u>	<u>REPCL</u>	<u>RAPCL</u>	<u>RSPCL</u>
Default	-	-	-	-	-	-	-	-

Bit 7: Receive FCS Errored Packet Latched (REPL) This bit is set when a packet with an errored FCS is detected.

Bit 6: Receive Aborted Packet Latched (RAPL) This bit is set when a packet with an abort indication is detected.

Bit 5: Receive Invalid Packet Detected Latched (RIPDL) This bit is set when a packet with a noninteger number of bytes is detected.

Bit 4: Receive Small Packet Detected Latched (RSPDL) This bit is set when a packet smaller than the minimum packet size is detected.

Bit 3: Receive Large Packet Detected Latched (RLPDL) This bit is set when a packet larger than the maximum packet size is detected.

Bit 2: Receive FCS Errored Packet Count Latched (REPCL) This bit is set when the REPC bit in the RPPSR register transitions from zero to one.

Bit 1: Receive Aborted Packet Count Latched (RAPCL) This bit is set when the RAPC bit in the RPPSR register transitions from zero to one.

Bit 0: Receive Size Violation Packet Count Latched (RSPCL) This bit is set when the RSPC bit in the RPPSR register transitions from zero to one.

Register Name: **LI.RPPSRIE**
 Register Description: **Receive Packet Processor Status Register Interrupt Enable**
 Register Address: **106h**

Bit #	7	6	5	4	3	2	1	0
Name	REPIE	RAPIE	RIPDIE	RSPDIE	RLPDIE	REPCIE	RAPCIE	RSPCIE
Default	0	0	0	0	0	0	0	0

Bit 7: Receive FCS Errored Packet Interrupt Enable (REPIE) This bit enables an interrupt if the REPL bit in the [LI.RPPSRL](#) register is set.

0 = interrupt disabled
 1 = interrupt enabled

Bit 6: Receive Aborted Packet Interrupt Enable (RAPIE) This bit enables an interrupt if the RAPL bit in the [LI.RPPSRL](#) register is set.

0 = interrupt disabled
 1 = interrupt enabled

Bit 5: Receive Invalid Packet Detected Interrupt Enable (RIPDIE) This bit enables an interrupt if the RIPDL bit in the [LI.RPPSRL](#) register is set.

0 = interrupt disabled
 1 = interrupt enabled

Bit 4: Receive Small Packet Detected Interrupt Enable (RSPDIE) This bit enables an interrupt if the RSPDL bit in the [LI.RPPSRL](#) register is set.

0 = interrupt disabled
 1 = interrupt enabled

Bit 3: Receive Large Packet Detected Interrupt Enable (RLPDIE) This bit enables an interrupt if the RLPDL bit in the [LI.RPPSRL](#) register is set.

0 = interrupt disabled
 1 = interrupt enabled

Bit 2: Receive FCS Errored Packet Count Interrupt Enable (REPCIE) This bit enables an interrupt if the REPCL bit in the [LI.RPPSRL](#) register is set. Must be set low when the packets do not have an FCS appended.

0 = interrupt disabled
 1 = interrupt enabled

Bit 1: Receive Aborted Packet Count Interrupt Enable (RAPCIE) This bit enables an interrupt if the RAPCL bit in the [LI.RPPSRL](#) register is set.

0 = interrupt disabled
 1 = interrupt enabled

Bit 0: Receive Size Violation Packet Count Interrupt Enable (RSPCIE) This bit enables an interrupt if the RSPCL bit in the [LI.RPPSRL](#) register is set.

0 = interrupt disabled
 1 = interrupt enabled

Register Name: **LI.RPCB0**
 Register Description: **Receive Packet Count Byte 0 Register**
 Register Address: **108h**

Bit #	7	6	5	4	3	2	1	0
Name	<u>RPC7</u>	<u>RPC6</u>	<u>RPC5</u>	<u>RPC4</u>	<u>RPC3</u>	<u>RPC2</u>	<u>RPC1</u>	<u>RPC0</u>
Default	0	0	0	0	0	0	0	0

Bits 0 - 7: Receive Packet Count (RPC [7:0]) Eight bits of a 24-bit value. Register description below.

Register Name: **LI.RPCB1**
 Register Description: **Receive Packet Count Byte 1 Register**
 Register Address: **109h**

Bit #	7	6	5	4	3	2	1	0
Name	<u>RPC15</u>	<u>RPC14</u>	<u>RPC13</u>	<u>RPC12</u>	<u>RPC11</u>	<u>RPC10</u>	<u>RPC09</u>	<u>RPC08</u>
Default	0	0	0	0	0	0	0	0

Bits 0 - 7: Receive Packet Count (RPC [15:8]) Eight bits of a 24-bit value. Register description below.

Register Name: **LI.RPCB2**
 Register Description: **Receive Packet Count Byte 2 Register**
 Register Address: **10Ah**

Bit #	7	6	5	4	3	2	1	0
Name	<u>RPC23</u>	<u>RPC22</u>	<u>RPC21</u>	<u>RPC20</u>	<u>RPC19</u>	<u>RPC18</u>	<u>RPC17</u>	<u>RPC16</u>
Default	0	0	0	0	0	0	0	0

Bits 0 - 7: Receive Packet Count (RPC [23:16]) These twenty-four bits indicate the number of packets stored in the receive FIFO without an abort indication. Note: Packets discarded due to system loopback or an overflow condition are included in this count. This register is valid when clear channel is enabled.

Register Name: **LI.RFPCB0**
 Register Description: **Receive FCS Errored Packet Count Byte 0 Register**
 Register Address: **10Ch**

Bit #	7	6	5	4	3	2	1	0
Name	<u>RFPC7</u>	<u>RFPC6</u>	<u>RFPC5</u>	<u>RFPC4</u>	<u>RFPC3</u>	<u>RFPC2</u>	<u>RFPC1</u>	<u>RFPC0</u>
Default	0	0	0	0	0	0	0	0

Bits 0 – 7: Receive FCS Errored Packet Count (RFPC[7:0]) Eight bits of a 24-bit value. Register description below.

Register Name: **LI.RFPCB1**
 Register Description: **Receive FCS Errored Packet Count Byte 1 Register**
 Register Address: **10Dh**

Bit #	7	6	5	4	3	2	1	0
Name	<u>RFPC15</u>	<u>RFPC14</u>	<u>RFPC13</u>	<u>RFPC12</u>	<u>RFPC11</u>	<u>RFPC10</u>	<u>RFPC9</u>	<u>RFPC8</u>
Default	0	0	0	0	0	0	0	0

Bits 0 – 7: Receive FCS Errored Packet Count (RFPC[15:8]) Eight bits of a 24-bit value. Register description below.

Register Name: **LI.RFPCB2**
 Register Description: **Receive FCS Errored Packet Count Byte 2 Register**
 Register Address: **10Eh**

Bit #	7	6	5	4	3	2	1	0
Name	<u>RFPC23</u>	<u>RFPC22</u>	<u>RFPC21</u>	<u>RFPC20</u>	<u>RFPC19</u>	<u>RFPC18</u>	<u>RFPC17</u>	<u>RFPC16</u>
Default	0	0	0	0	0	0	0	0

Receive FCS Errored Packet Count (RFPC[23:16]) These twenty-four bits indicate the number of packets received with an FCS error. The byte count for these packets is included in the receive aborted byte count register REBCR.

Register Name: **LI.RAPCB0**
 Register Description: **Receive Aborted Packet Count Byte 0 Register**
 Register Address: **110h**

Bit #	7	6	5	4	3	2	1	0
Name	<u>RAPC7</u>	<u>RAPC6</u>	<u>RAPC5</u>	<u>RAPC4</u>	<u>RAPC3</u>	<u>RAPC2</u>	<u>RAPC1</u>	<u>RAPC0</u>
Default	0	0	0	0	0	0	0	0

Bits 0 - 7: Receive Aborted Packet Count (RAPC [7:0]) Eight bits of a 24-bit value. Register description below.

Register Name: **LI.RAPCB1**
 Register Description: **Receive Aborted Packet Count Byte 1 Register**
 Register Address: **111h**

Bit #	7	6	5	4	3	2	1	0
Name	<u>RAPC15</u>	<u>RAPC14</u>	<u>RAPC13</u>	<u>RAPC12</u>	<u>RAPC11</u>	<u>RAPC10</u>	<u>RAPC9</u>	<u>RAPC8</u>
Default	0	0	0	0	0	0	0	0

Bits 0 - 7: Receive Aborted Packet Count (RAPC[15:8]) Eight bits of a 24-bit value. Register description below.

Register Name: **LI.RAPCB2**
 Register Description: **Receive Aborted Packet Count Byte 2 Register**
 Register Address: **112h**

Bit #	7	6	5	4	3	2	1	0
Name	<u>RAPC23</u>	<u>RAPC22</u>	<u>RAPC21</u>	<u>RAPC20</u>	<u>RAPC19</u>	<u>RAPC18</u>	<u>RAPC17</u>	<u>RAPC16</u>
Default	0	0	0	0	0	0	0	0

Bits 0 – 7: Receive Aborted Packet Count (RAPC [23:16]) The twenty-four bit value from these three registers indicates the number of packets received with a packet abort indication. The byte count for these packets is included in the receive aborted byte count register REBCR.

Register Name: **LI.RSPCB0**
 Register Description: **Receive Size Violation Packet Count Byte 0 Register**
 Register Address: **114h**

Bit #	7	6	5	4	3	2	1	0
Name	<u>RSPC7</u>	<u>RSPC6</u>	<u>RSPC5</u>	<u>RSPC4</u>	<u>RSPC3</u>	<u>RSPC2</u>	<u>RSPC1</u>	<u>RSPC0</u>
Default	0	0	0	0	0	0	0	0

Bits 0 - 7: Receive Size Violation Packet Count (RSPC [7:0]) Eight bits of a 24-bit value. Register description below.

Register Name: **LI.RSPCB1**
 Register Description: **Receive Size Violation Packet Count Byte 1 Register**
 Register Address: **115h**

Bit #	7	6	5	4	3	2	1	0
Name	<u>RSPC15</u>	<u>RSPC14</u>	<u>RSPC13</u>	<u>RSPC12</u>	<u>RSPC11</u>	<u>RSPC10</u>	<u>RSPC9</u>	<u>RSPC8</u>
Default	0	0	0	0	0	0	0	0

Bits 0 - 7: Receive Size Violation Packet Count (RSPC [15:8]) Eight bits of a 24-bit value. Register description below.

Register Name: **LI.RSPCB2**
 Register Description: **Receive Size Violation Packet Count Byte 2 Registers**
 Register Address: **116h**

Bit #	7	6	5	4	3	2	1	0
Name	<u>RSPC23</u>	<u>RSPC22</u>	<u>RSPC21</u>	<u>RSPC20</u>	<u>RSPC19</u>	<u>RSPC18</u>	<u>RSPC17</u>	<u>RSPC16</u>
Default	0	0	0	0	0	0	0	0

Bits 0 - 7: Receive Size Violation Packet Count (RSPC [23:16]) These twenty-four bits indicate the number of packets received with a packet size violation (below minimum, above maximum, or noninteger number of bytes). The byte count for these packets is included in the receive aborted byte count register REBCR.

Register Name: **LI.RBC0**
 Register Description: **Receive Byte Count 0 Register**
 Register Address: **118h**

Bit #	7	6	5	4	3	2	1	0
Name	<u>RBC7</u>	<u>RBC6</u>	<u>RBC5</u>	<u>RBC4</u>	<u>RBC3</u>	<u>RBC2</u>	<u>RBC1</u>	<u>RBC0</u>
Default	0	0	0	0	0	0	0	0

Bits 0 - 7: Receive Byte Count (RBC [7:0]) Eight bits of a 32-bit value. Register description below.

Register Name: **LI.RBC1**
 Register Description: **Receive Byte Count 1 Register**
 Register Address: **119h**

Bit #	7	6	5	4	3	2	1	0
Name	<u>RBC15</u>	<u>RBC14</u>	<u>RBC13</u>	<u>RBC12</u>	<u>RBC11</u>	<u>RBC10</u>	<u>RBC9</u>	<u>RBC8</u>
Default	0	0	0	0	0	0	0	0

Bits 0 - 7: Receive Byte Count (RBC [15:8]) Eight bits of a 32-bit value. Register description below.

Register Name: **LI.RBC2**
 Register Description: **Receive Byte Count 2 Register**
 Register Address: **11Ah**

Bit #	7	6	5	4	3	2	1	0
Name	<u>RBC23</u>	<u>RBC22</u>	<u>RBC21</u>	<u>RBC20</u>	<u>RBC19</u>	<u>RBC18</u>	<u>RBC17</u>	<u>RBC16</u>
Default	0	0	0	0	0	0	0	0

Bits 0 - 7: Receive Byte Count (RBC [23:16]) Eight bits of a 32-bit value. Register description below.

Register Name: **LI.RBC3**
 Register Description: **Receive Byte Count 3 Register**
 Register Address: **11Bh**

Bit #	7	6	5	4	3	2	1	0
Name	<u>RBC31</u>	<u>RBC30</u>	<u>RBC29</u>	<u>RBC28</u>	<u>RBC27</u>	<u>RBC26</u>	<u>RBC25</u>	<u>RBC24</u>
Default	0	0	0	0	0	0	0	0

Bits 0 - 7: Receive Byte Count (RBC [31:24]) These thirty-two bits indicate the number of bytes contained in packets stored in the receive FIFO without an abort indication. Note: Bytes discarded due to FCS extraction, system loopback, FIFO reset, or an overflow condition may be included in this count.

Register Name: **LI.RAC0**
 Register Description: **Receive Aborted Byte Count 0 Register**
 Register Address: **11Ch**

Bit #	7	6	5	4	3	2	1	0
Name	<u>REBC7</u>	<u>REBC6</u>	<u>REBC5</u>	<u>REBC4</u>	<u>REBC3</u>	<u>REBC2</u>	<u>REBC1</u>	<u>REBC0</u>
Default	0	0	0	0	0	0	0	0

Bits 0 - 7: Receive Aborted Byte Count (RBC [7:0]) Eight bits of a 32-bit value. Register description below.

Register Name: **LI.RAC1**
 Register Description: **Receive Aborted Byte Count 1 Register**
 Register Address: **11Dh**

Bit #	7	6	5	4	3	2	1	0
Name	<u>REBC15</u>	<u>REBC14</u>	<u>REBC13</u>	<u>REBC12</u>	<u>REBC11</u>	<u>REBC10</u>	<u>REBC9</u>	<u>REBC8</u>
Default	0	0	0	0	0	0	0	0

Bits 0 - 7: Receive Aborted Byte Count (RBC [15:8]) Eight bits of a 32-bit value. Register description below.

Register Name: **LI.RAC2**
 Register Description: **Receive Aborted Byte Count 2 Register**
 Register Address: **11Eh**

Bit #	7	6	5	4	3	2	1	0
Name	<u>REBC23</u>	<u>REBC22</u>	<u>REBC21</u>	<u>REBC20</u>	<u>REBC19</u>	<u>REBC18</u>	<u>REBC17</u>	<u>REBC16</u>
Default	0	0	0	0	0	0	0	0

Bits 0 - 7: Receive Aborted Byte Count (RBC [16:23]) Eight bits of a 32-bit value. Register description below.

Register Name: **LI.RAC3**
 Register Description: **Receive Aborted Byte Count 3 Register**
 Register Address: **11Fh**

Bit #	7	6	5	4	3	2	1	0
Name	<u>REBC31</u>	<u>REBC30</u>	<u>REBC29</u>	<u>REBC28</u>	<u>REBC27</u>	<u>REBC26</u>	<u>REBC25</u>	<u>REBC24</u>
Default	0	0	0	0	0	0	0	0

Bits 0 - 7: Receive Aborted Byte Count (REBC[31:24]) These thirty-two bits indicate the number of bytes contained in packets stored in the receive FIFO with an abort indication. Note: Bytes discarded due to FCS extraction, system loopback, FIFO reset, or an overflow condition may be included in this count.

Register Name: **LI.RHPMUU**
 Register Description: **Serial Interface Receive HDLC PMU Update Register**
 Register Address: **120h**

Bit #	7	6	5	4	3	2	1	0
Name	-	-	-	-	-	-	-	RPMUU
Default	0	0	0	0	0	0	0	0

Bit 0: Receive PMU Update (RPMUU) This signal causes the receive cell/packet processor block performance monitoring registers (counters) to be updated. A 0 to 1 transition causes the performance monitoring registers to be updated with the latest data, and the counters reset (0 or 1). This update updates performance monitoring counters for the Serial Interface.

Register Name: **LI.RHPMUS**
 Register Description: **Serial Interface Receive HDLC PMU Update Status Register**
 Register Address: **121h**

Bit #	7	6	5	4	3	2	1	0
Name	-	-	-	-	-	-	-	RPMUUS
Default	0	0	0	0	0	0	0	0

Bit 0: Receive PMU Update Status (RPMUUS) This bit is set when the Transmit PMU Update is completed. This bit is cleared when RPMUU is set to 0.

Register Name: **LI.RX86S**
 Register Description: **Receive X.86 Latched Status Register**
 Register Address: **122h**

Bit #	7	6	5	4	3	2	1	0
Name	-	-	-	-	SAPIHNE	SAPILNE	CNE	ANE
Default	-	-	-	-	-	-	-	-

Bit 3: SAPI High is not equal to [LI.TRX86SAPIH](#) Latched Status (SAPIHNE) This latched status bit is set if SAPIH is not equal to LI.TRX86SAPIH. This latched status bit is cleared upon read.

Bit 2: SAPI Low is not equal to [LI.TRX86SAPIL](#) Latched Status (SAPILNE) This latched status bit is set if SAPIL is not equal to LI.TRX86SAPIL. This latched status bit is cleared upon read.

Bit 1: Control is not equal to [LI.TRX8C](#) (CNE) This latched status bit is set if the control field is not equal to LI.TRX8C. This latched status bit is cleared upon read.

Bit 0: Address is not equal to [LI.TRX86A](#) (ANE) This latched status bit is set if the X.86 Address field is not equal to LI.TRX86A. This latched status bit is cleared upon read.

Register Name: **LI.RX86LSIE**
 Register Description: **Receive X.86 Interrupt Enable**
 Register Address: **123h**

Bit #	7	6	5	4	3	2	1	0
Name	-	-	-	-	SAPINE01IM	SAPINEFEIM	CNE3LI M	ANE4IM
Default	0	0	0	0	0	0	0	0

Bit 3: SAPI Octet not equal to [LI.TRX86SAPIH](#) Interrupt Enable (SAPINE01IM) If this bit is set to 1, LI.RX86S.SAPIHNE will generate an interrupt.

Bit 2: SAPI Octet not equal to [LI.TRX86SAPIL](#) Interrupt Enable (SAPINEFEIM) If this bit is set to 1, LI.RX86S.SAPILNE will generate an interrupt.

Bit 1: Control not equal to [LI.TRX8C](#) Interrupt Enable (CNE3LIM) If this bit is set to 1, LI.RX86S.CNE will generate an interrupt.

Bit 0: Address not equal to [LI.TRX86A](#) Interrupt Enable (ANE4IM) If this bit is set to 1, LI.RX86S.ANE will generate an interrupt.

Register Name: **LI.TQLT**
 Register Description: **Serial Interface Transmit Queue Low Threshold (Watermark)**
 Register Address: **124h**

Bit #	7	6	5	4	3	2	1	0
Name	TQLT7	TQLT6	TQLT5	TQLT4	TQLT3	TQLT2	TQLT1	TQLT0
Default	0	0	0	0	0	0	0	0

Bits 0 - 7: Transmit Queue Low Threshold (TQLT[0:7]) The transmit queue low threshold for the connection, in increments of 32 packets of 2048 bytes each. The value of this register is multiplied by 32 * 2048 bytes to determine the byte location of the threshold. Note that the transmit queue is for data that was received from the Serial Interface to be sent to the Ethernet Interface.

Register Name: **LI.TQHT**
 Register Description: **Serial Interface Transmit Queue High Threshold (Watermark)**
 Register Address: **125h**

Bit #	7	6	5	4	3	2	1	0
Name	TQHT7	TQHT6	TQHT5	TQHT4	TQHT3	TQHT2	TQHT1	TQHT0
Default	0	0	0	0	0	0	0	0

Bits 0 - 7: Transmit Queue High Threshold (TQHT[0:7]) The transmit queue high threshold for the connection, in increments of 32 packets of 2048 bytes each. The value of this register is multiplied by 32 * 2048 bytes to determine the byte location of the threshold. Note that the transmit queue is for data that was received from the Serial Interface to be sent to the Ethernet Interface.

Register Name: **LI.TQTIE**
 Register Description: **Serial Interface Transmit Queue Cross Threshold Interrupt Enable**
 Register Address: **126h**

Bit #	7	6	5	4	3	2	1	0
Name	-	-	-	-	TFOVFIE	TQOVFIE	TQHTIE	TQLTIE
Default	0	0	0	0	0	0	0	0

Bit 3: Transmit FIFO Overflow for Connection Interrupt Enable (TFOVFIE) If this bit is set, the watermark interrupt is enabled for TFOVFLS.

Bit 2: Transmit Queue Overflow for Connection Interrupt Enable (TQOVFIE) If this bit is set, the watermark interrupt is enabled for TQOVFLS.

Bit 1: Transmit Queue for Connection High Threshold Interrupt Enable (TQHTIE) If this bit is set, the watermark interrupt is enabled for TQHTS.

Bit 0: Transmit Queue for Connection Low Threshold Interrupt Enable (TQLTIE) If this bit is set, the watermark interrupt is enabled for TQLTS.

Register Name: **LI.TQCTLS**
 Register Description: **Serial Interface Transmit Queue Cross Threshold Latched Status**
 Register Address: **127h**

Bit #	7	6	5	4	3	2	1	0
Name	-	-	-	-	TFOVFLS	TQOVFLS	TQHTLS	TQLTLS
Default	-	-	-	-	-	-	-	-

Bit 3: Transmit Queue FIFO Overflowed Latched Status (TFOVFLS) This bit is set if the transmit queue FIFO has overflowed. This register is cleared after a read. This FIFO is for data to be transmitted from the HDLC to be sent to the SDRAM.

Bit 2: Transmit Queue Overflow Latched Status (TQOVFLS) This bit is set if the transmit queue has overflowed. This register is cleared after a read.

Bit 1: Transmit Queue for Connection Exceeded High Threshold Latched Status (TQHTLS) This bit is set if the transmit queue crosses the High Watermark. This register is cleared after a read.

Bit 0: Transmit Queue for Connection Exceeded Low Threshold Latched Status (TQLTLS) This bit is set if the transmit queue crosses the Low Watermark. This register is cleared after a read.

11.6 Ethernet Interface Registers

The Ethernet Interface registers are used to configure RMII/MII bus operation and establish the MAC parameters as required by the user. The MAC Registers cannot be addressed directly from the Processor port. The registers below are used to perform indirect read or write operations to the MAC registers. The MAC Status Registers are shown in [Table 11-7](#). Accessing the MAC Registers is described in the Section [9.15](#).

11.6.1 Ethernet Interface Register Bit Descriptions

Register Name: **SU.MACRADL**
 Register Description: **MAC Read Address Low Register**
 Register Address: **140h**

Bit #	7	6	5	4	3	2	1	0
Name	MACRA7	MACRA6	MACRA5	MACRA4	MACRA3	MACRA2	MACRA1	MACRA0
Default	0	0	0	0	0	0	0	0

Bits 0 – 7: MAC Read Address (MACRA0-7) Low byte of the MAC indirect register address. Used only for read operations.

Register Name: **SU.MACRADH**
 Register Description: **MAC Read Address High Register**
 Register Address: **141h**

Bit #	7	6	5	4	3	2	1	0
Name	MACRA1	MACRA1	MACRA1	MACRA1	MACRA1	MACRA1	MACRA9	MACRA8
	5	4	3	2	1	0		
Default	0	0	0	0	0	0	0	0

Bits 0 – 7: MAC Read Address (MACRA8-15) High byte of the MAC indirect register address. Used only for read operations.

Register Name: **SU.MACRD0**
 Register Description: **MAC Read Data Byte 0**
 Register Address: **142h**

Bit #	7	6	5	4	3	2	1	0
Name	MACRD7	MACRD6	MACRD5	MACRD4	MACRD3	MACRD2	MACRD1	MACRD0
Default	0	0	0	0	0	0	0	0

Bits 0 – 7: MAC Read Data 0 (MACRD0-7) One of four bytes of data read from the MAC. Valid after a read command has been issued and the [SU.MACRWC](#).MCS bit is zero.

Register Name: **SU.MACRD1**
 Register Description: **MAC Read Data Byte 1**
 Register Address: **143h**

Bit #	7	6	5	4	3	2	1	0
Name	MACRD15	MACRD14	MACRD13	MACRD12	MACRD11	MACRD10	MACRD9	MACRD8
Default	0	0	0	0	0	0	0	0

Bits 0 - 7: MAC Read Data 1 (MACRD8-15) One of four bytes of data read from the MAC. Valid after a read command has been issued and the [SU.MACRWC.MCS](#) bit is zero.

Register Name: **SU.MACRD2**
 Register Description: **MAC Read Data Byte 2**
 Register Address: **144h**

Bit #	7	6	5	4	3	2	1	0
Name	MACRD23	MACRD22	MACRD21	MACRD20	MACRD19	MACRD18	MACRD17	MACRD16
Default	0	0	0	0	0	0	0	0

Bits 0 – 7: MAC Read Data 2 (MACRD16-23) One of four bytes of data read from the MAC. Valid after a read command has been issued and the [SU.MACRWC.MCS](#) bit is zero.

Register Name: **SU.MACRD3**
 Register Description: **MAC Read Data byte 3**
 Register Address: **145h**

Bit #	7	6	5	4	3	2	1	0
Name	MACRD31	MACRD30	MACRD29	MACRD28	MACRD27	MACRD26	MACRD25	MACRD24
Default	0	0	0	0	0	0	0	0

Bits 0 – 7: MAC Read Data 3 (MACRD24-31) One of four bytes of data read from the MAC. Valid after a read command has been issued and the [SU.MACRWC.MCS](#) bit is zero.

Register Name: **SU.MACWD0**
 Register Description: **MAC Write Data 0**
 Register Address: **146h**

Bit #	7	6	5	4	3	2	1	0
Name	MACWD7	MACWD6	MACWD5	MACWD4	MACWD3	MACWD2	MACWD1	MACWD0
Default	0	0	0	0	0	0	0	0

Bits 0 – 7: MAC Write Data 0 (MACWD0-7) One of four bytes of data to be written to the MAC. Data has been written after a write command has been issued and the [SU.MACRWC.MCS](#) bit is zero.

Register Name: **SU.MACWD1**
 Register Description: **MAC Write Data 1**
 Register Address: **147h**

Bit #	7	6	5	4	3	2	1	0
Name	MACWD15	MACWD14	MACWD13	MACWD12	MACWD11	MACWD10	MACWD09	MACWD08
Default	0	0	0	0	0	0	0	0

Bits 0 – 7: MAC Write Data 1 (MACWD8-15) One of four bytes of data to be written to the MAC. Data has been written after a write command has been issued and the [SU.MACRWC.MCS](#) bit is zero.

Register Name: **SU.MACWD2**
 Register Description: **MAC Write Data Register 2**
 Register Address: **148h**

Bit #	7	6	5	4	3	2	1	0
Name	MACWD23	MACWD22	MACWD21	MACWD20	MACWD19	MACWD18	MACWD17	MACWD16
Default	0	0	0	0	0	0	0	0

Bits 0 - 7: MAC Write Data 2 (MACWD16-23) One of four bytes of data to be written to the MAC. Data has been written after a write command has been issued and the [SU.MACRWC.MCS](#) bit is zero.

Register Name: **SU.MACWD3**
 Register Description: **MAC Write Data 3**
 Register Address: **149h**

Bit #	7	6	5	4	3	2	1	0
Name	MACD31	MACD30	MACD29	MACD28	MACD27	MACD26	MACD25	MACD24
Default	0	0	0	0	0	0	0	0

Bits 0 – 7: MAC Write Data 3 (MACD24-31) One of four bytes of data to be written to the MAC. Data has been written after a write command has been issued and the [SU.MACRWC.MCS](#) bit is zero.

Register Name: **SU.MACAWL**
 Register Description: **MAC Address Write Low**
 Register Address: **14Ah**

Bit #	7	6	5	4	3	2	1	0
Name	MACAW 7	MACAW 6	MACAW 5	MACAW4	MACAW3	MACAW2	MACAW1	MACAW0
Default	0	0	0	0	0	0	0	0

Bits 0 -7: MAC Write Address (MACAW0-7) Low byte of the MAC indirect write address. Used only for write operations.

Register Name: **SU.MACAWH**
 Register Description: **MAC Address Write High**
 Register Address: **14Bh**

Bit #	7	6	5	4	3	2	1	0
Name	MACAW15	MACAW14	MACAW13	MACAW12	MACAW11	MACAW10	MACAW9	MACAW8
Default	0	0	0	0	0	0	0	0

Bits 0 – 7: MAC Write Address (MACAW8-15) High byte of the MAC indirect write address. Used only for write operations.

Register Name: **SU.MACRWC**
 Register Description: **MAC Read Write Command Status**
 Register Address: **14Ch**

Bit #	7	6	5	4	3	2	1	0
Name	-	-	-	-	-	-	MCRW	MCS
Default	0	0	0	0	0	0	0	0

Bit 1: MAC Command RW (MCRW) If this bit is written to 1, a read is performed from the MAC. If this bit is written to 0, a write operation is performed. Address information for write operations must be located in [SU.MACAWH](#) and [SU.MACAWL](#). Address information for read operations must be located in [SU.MACRADH](#) and [SU.MACRADL](#). The user must also write a 1 to the MCS bit, and the DS33R11 will clear MCS when the operation is complete.

Bit 0: MAC Command Status (MCS) Setting MCS in conjunction with MCRW will initiate a read or write to the MAC registers. Upon completion of the read or write this bit is cleared. Once a read or write command has been initiated the host must poll this bit to see when the operation is complete.

Register Name: **SU.LPBK**
 Register Description: **Ethernet Interface Loopback Control Register**
 Register Address: **14Fh**

Bit #	7	6	5	4	3	2	1	0
Name	-	-	-	-	-	-	-	QLP
Default	0	0	0	0	0	0	0	0

Bit 0: Queue Loopback Enable (QLP) If this bit is set to 1, data from the Ethernet Interface receive queue is looped back to the transmit queue. Buffered data from the serial interface will remain until the loopback is removed.

Register Name: **SU.GCR**
 Register Description: **Ethernet Interface General Control Register**
 Register Address: **150h**

Bit #	7	6	5	4	3	2	1	0
Name	-	-	-	-	CRCS	H10S	ATFLOW	JAME
Default	0	0	0	0	0	0	1	0

Bit 3: CRCS If this bit is zero (default), the received MAC or Ethernet Frame CRC is stripped before the data is encapsulated and transmitted on the serial interface. Data received from the serial interface is decapsulated, a CRC is recalculated and appended to the packet for transmission to the Ethernet interface. If this bit is set to 1, the CRC is not stripped from received packets prior to encapsulation and transmission to the serial interface, and data received from the serial interface is decapsulated directly. No CRC recalculation is performed on data received from the serial interface. Note that the maximum packet size supported by the Ethernet interface is still 2016 (this includes the 4 bytes of CRC).

Bit 2: H10S This bit controls the 10/100 selection for RMII and DCE Mode. **When in RMII mode**, setting this bit to 1 will cause the MAC will operate at 100 Mbps and setting this bit to zero will cause the MAC to operate at 10 Mbps. **When in DCE mode**, the bit function is inverted – setting this bit to 1 will cause the MAC to operate at 10 Mbps. In DTE and MII mode, the MAC determines the data rate from the incoming TX_CLK and RX_CLK.

Bit 1: Automatic Flow Control Enable (ATFLOW) If this bit is set to 1, automatic flow control is enabled based on the connection receive queue size and high watermarks. Pause frames are sent automatically in full duplex mode. The pause time must be programmed through [SU.MACFCR](#). The jam sequence will not be sent automatically in half duplex mode unless the JAME bit is set. This bit is applicable only in software mode.

Bit 0: Jam Enable (JAME) If this bit is set to 1, a Jam sequence is sent for a duration of 4 bytes. This function is only valid in half duplex mode, and will only function if Automatic Flow Control is disabled. Note that if the receive queue size is less than receive high threshold, setting a JAME will JAM one received frame. If JAME is set and the receiver queue size is higher than the high threshold, all received frames are jammed until the queue empties below the threshold.

Note that [SU.GCR](#) is only valid in the software mode.

Register Name: **SU.TFRC**
 Register Description: **Transmit Frame Resend Control**
 Register Address: **151h**

Bit #	7	6	5	4	3	2	1	0
Name	-	-	-	-	NCFQ	TPDFCB	TPRHBC	TPRCB
Default	0	0	0	0	0	0	0	0

Bit 3: No Carrier Queue Flush Bar (NCFQ) If this bit is set to 1, the queue for data passing from Serial Interface to Ethernet Interface will not be flushed when loss of carrier is detected.

Bit 2: Transmit Packet Deferred Fail Control Enable (TPDFCB) If this bit is set to 1, the current frame is transmitted immediately instead of being deferred. If this bit is set to 0, the frame is deferred if CRS is asserted and sent when the CRS is unasserted indicating the media is idle.

Bit 1: Transmit Packet HB Fail Control Bar (TPRHBC) If this bit is set to 1, the current frame will not be retransmitted if a heartbeat failure is detected.

Bit 0: Transmit Packet Resend Control Bar (TPRCB) If this bit is set to 1, the current frame will not be retransmitted if any of the following errors have occurred:

- Jabber time out
- Loss of carrier
- Excessive deferral
- Late collision
- Excessive collisions
- Under run
- Collision

Note that blocking retransmission due to collision (applicable in MII/Half Duplex Mode) can result in unpredictable system level behavior.

Register Name: **SU.TFSL**
 Register Description: **Transmit Frame Status Low**
 Register Address: **152h**

Bit #	7	6	5	4	3	2	1	0
Name	UR	EC	LC	ED	LOC	NOC	-	FABORT
Default	0	0	0	0	0	0	0	0

Bit 7: Under Run (UR) When this bit is set to 1, the frame was aborted due to a data under run condition of the transmit buffer.

Bit 6: Excessive Collisions (EC) When this bit is set to 1, a frame has been aborted after 16 successive collisions while attempting to transmit the current frame. If the Disable Retry bit is set to 1, then Excessive Collisions will be set to 1 after the first collision.

Bit 5: Late Collision (LC) When this bit is set to 1, a frame was aborted by collision after the 64 bit collision window. Not valid if an under run has occurred.

Bit 4: Excessive Deferral (ED) When this bit is set to 1, a frame was aborted due to excessive deferral.

Bit 3: Loss Of Carrier (LOC) When this bit is set to 1, a frame was aborted due to loss of carrier for one or more bit times. Valid only for noncollided frames. Valid only in half-duplex operation.

Bit 2: No Carrier (NOC) When this bit is set to 1, a frame was aborted because no carrier was found for transmission.

Bit 1: Reserved

Bit 0: Frame Abort (FABORT) When this bit is set to 1, the MAC has aborted a frame for one of the above reasons. When this bit is clear, the previous frame has been transmitted successfully.

Register Name: **SU.TFSH**
 Register Description: **Transmit Frame Status High**
 Register Address: **153h**

Bit #	7	6	5	4	3	2	1	0
Name	PR	HBF	CC3	CC2	CC1	CC0	LCO	DEF
Default	0	0	0	0	0	0	0	0

Bit 7: Packet Resend (PR) When this bit is set, the current packet must be retransmitted due to a collision.

Bit 6: Heartbeat Failure (HBF) When this bit is set, the device failed to detect a heart beat after transmission. This bit is not valid if an under run has occurred.

Bits 2-5: Collision Count (CC0-3) These 4 bits indicate the number of collisions that occurred prior to successful transmission of the previous frame. Not valid if Excessive Collisions is set to 1.

Bit 1: Late Collision (LCO) When set to 1, the MAC observed a collision after the 64-byte collision window.

Bit 0: Deferred Frame (DEF) When set to 1, the current frame was deferred due to carrier assertion by another node after being ready to transmit.

Register Name: **SU.RFSB0**
 Register Description: **Receive Frame Status Byte 0**
 Register Address: **154h**

Bit #	7	6	5	4	3	2	1	0
Name	FL7	FL6	FL5	FL4	FL3	FL2	FL1	FL0
Default	0	0	0	0	0	0	0	0

Bits 0 - 7: Frame Length (FL[0:7]) These 8 bits are the low byte of the length (in bytes) of the received frame, with FCS and Padding. If Automatic Pad Stripping is enabled, this value is the length of the received packet without PCS or Pad bytes. The upper 6 bits are contained in SU.RFSB1.

Register Name: **SU.RFSB1**
 Register Description: **Receive Frame Status Byte 1**
 Register Address: **155h**

Bit #	7	6	5	4	3	2	1	0
Name	RF	WT	FL13	FL12	FL11	FL10	FL9	FL8
Default	0	0	0	0	0	0	0	0

Bit 7: Runt Frame (RF) This bit is set to 1 if the received frame was altered by a collision or terminated within the collision window.

Bit 6: Watchdog Timeout (WT) This bit is set to 1 if a packet receive time exceeds 2048 byte times. After 2048 byte times the receiver is disabled and the received frame will fail CRC check.

Bits 0-5: Frame Length (FL[8:13]) These 6 bits are the upper bits of the length (in bytes) of the received frame, with FCS and Padding. If Automatic Pad Stripping is enabled, this value is the length of the received packet without PCS or Pad bytes.

Register Name: **SU.RFSB2**
 Register Description: **Receive Frame Status Byte 2**
 Register Address: **156h**

Bit #	7	6	5	4	3	2	1	0
Name	-	-	CRCE	DB	MIIE	FT	CS	FTL
Default	0	0	0	0	0	0	0	0

Bit 5: CRC Error (CRCE) This bit is set to 1 if the received frame does not contain a valid CRC value.

Bit 4: Dribbling Bit (DB) This bit is set to 1 if the received frame contains a noninteger multiple of 8 bits. It does not indicate that the frame is invalid. This bit is not valid for runt or collided frames.

Bit 3: MII Error (MIIE) This bit is set to 1 if an error was found on the MII bus.

Bit 2: Frame Type (FT) This bit is set to 1 if the received frame exceeds 1536 bytes. It is equal to zero if the received frame is an 802.3 frame. This bit is not valid for runt frames.

Bit 1: Collision Seen (CS) This bit is set to 1 if a late collision occurred on the received packet. A late collision is one that occurs after the 64 byte collision window.

Bit 0: Frame Too Long (FTL) This bit is set to 1 if a frame exceeds the 1518 byte maximum standard Ethernet frame. This bit is only an indication, and causes no frame truncation.

Register Name: **SU.RFSB3**
 Register Description: **Receive Frame Status Byte 3**
 Register Address: **157h**

Bit #	7	6	5	4	3	2	1	0
Name	MF	-	-	BF	MCF	UF	CF	LE
Default	0	0	0	0	0	0	0	0

Bit 7: Missed Frame (MF) This bit is set to 1 if the packet is not successfully received from the MAC by the packet Arbiter.

Bit 4: Broadcast Frame (BF) This bit is set to 1 if the current frame is a broadcast frame.

Bit 3: Multicast Frame (MCF) This bit is set to 1 if the current frame is a multicast frame.

Bit 2: Unsupported Control Frame (UF) This bit is set to 1 if the frame received is a control frame with an opcode that is not supported. If the Control Frame bit is set, and the Unsupported Control Frame bit is clear, then a pause frame has been received and the transmitter is paused.

Bit 1: Control Frame (CF) This bit is set to 1 when the current frame is a control frame. This bit is only valid in full-duplex mode.

Bit 0: Length Error (LE) This bit is set to 1 when the frames length field and the actual byte count are unequal. This bit is only valid for 802.3 frames.

Register Name: **SU.RMFSRL**
 Register Description: **Receiver Maximum Frame Low Register**
 Register Address: **158h**

Bit #	7	6	5	4	3	2	1	0
Name	RMPS7	RMPS6	RMPS5	RMPS4	RMPS3	RMPS2	RMPS1	RMPS0
Default	1	1	1	0	0	0	0	0

Bits 7- 0: Receiver Maximum Frame (RMPS[0:7]) Eight bits of sixteen bit value. Register description below.

Register Name: **SU.RMFSRH**
 Register Description: **Receiver Maximum Frame High Register**
 Register Address: **159h**

Bit #	7	6	5	4	3	2	1	0
Name	RMPS15	RMPS14	RMPS13	RMPS12	RMPS11	RMPS10	RMPS9	RMPS8
Default	0	0	0	0	0	1	1	1

Bits 7- 0: Receiver Maximum Frame (RMPS[8:15]) This value is the receiver's maximum frame size (in bytes), up to a maximum of 2016 bytes. Any frame received greater than this value is rejected. The frame size includes destination address, source address, type/length, data and crc-32. The frame size is not the same as the frame length encoded within the IEEE 802.3 frame. **Any values programmed that are greater than 2016 will have unpredictable behavior and should be avoided.**

Register Name: **SU.RQLT**
 Register Description: **Receive Queue Low Threshold (Watermark)**
 Register Address: **15Ah**

Bit #	7	6	5	4	3	2	1	0
Name	RQLT7	RQLT6	RQLT5	RQLT4	RQLT3	RQLT2	RQLT1	RQLT0
Default	0	0	0	0	0	0	0	0

Bits 0 - 7: Receive Queue Low Threshold (RQLT[0:7]) The receive queue low threshold for the connection, in increments of 32 packets of 2048 bytes each. The value of this register is multiplied by 32 * 2048 bytes to determine the byte location of the threshold. Note that the receive queue is for data that was received from the Ethernet Interface to be sent to the Serial Interface.

Register Name: **SU.RQHT**
 Register Description: **Receive Queue High Threshold (Watermark)**
 Register Address: **15Bh**

Bit #	7	6	5	4	3	2	1	0
Name	RQHT7	RQHT6	RQHT5	RQHT4	RQHT3	RQHT2	RQHT1	RQHT0
Default	0	0	0	0	0	0	0	0

Bits 0 – 7: Receive Queue High Threshold (RQTH[0:7]) The receive queue high threshold for the connection, in increments of 32 packets of 2048 bytes each. The value of this register is multiplied by 32 * 2048 bytes to determine the byte location of the threshold. Note that the receive queue is for data that was received from the Ethernet Interface to be sent to the Serial Interface.

Register Name: **SU.QRIE**
 Register Description: **Receive Queue Cross Threshold enable**
 Register Address: **15Ch**

Bit #	7	6	5	4	3	2	1	0
Name	-	-	-	-	RFOVFIE	RQVFIE	RQLTIE	RQHTIE
Default	0	0	0	0	0	0	0	0

Bit 3: Receive FIFO Overflow Interrupt Enable (RFOVFIE) If this bit is set, the interrupt is enabled for RFOVFLS.

Bit 2: Receive Queue Overflow Interrupt Enable (RQVFIE) If this bit is set, the interrupt is enabled for RQOVFLS.

Bit 1: Receive Queue Crosses Low Threshold Interrupt Enable (RQLTIE) If this bit is set, the watermark interrupt is enabled for RQLTS.

Bit 0: Receive Queue Crosses High Threshold Interrupt Enable (RQHTIE) If this bit is set, the watermark interrupt is enabled for RQHTS.

Register Name: **SU.QCRLS**
 Register Description: **Queue Cross Threshold Latched Status**
 Register Address: **15Dh**

Bit #	7	6	5	4	3	2	1	0
Name	-	-	-	-	RFOVFLS	RQOVFLS	RQHTLS	RQLTLS
Default	-	-	-	-	-	-	-	-

Bit 3: Receive FIFO Overflow latched Status (RFOVFLS) This bit is set if the receive FIFO overflows for the data to be transmitted from the MAC to the SDRAM.

Bit 2: Receive Queue Overflow Latched Status (RQOVFLS) This bit is set if the receive queue has overflowed. This register is cleared after a read.

Bit 1: Receive Queue for Connection Crossed High Threshold Latched Status (RQHTLS) This bit is set if the receive queue crosses the high Watermark. This register is cleared after a read.

Bit 0: Receive Queue for Connection Crossed Low Threshold Latched Status (RQLTLS) This bit is set if the receive queue crosses the low Watermark. This register is cleared after a read.

Note the bit order differences in the high/low threshold indications in SU.QCRLS and the interrupt enables in SU.QRIE.

Register Name: **SU.RFRC**
 Register Description: **Receive Frame Rejection Control**
 Register Address: **15Eh**

Bit #	7	6	5	4	3	2	1	0
Name	-	UCFR	CFRR	LERR	CRCERR	DBR	MIIER	BFR
Default	0	0	0	0	0	0	0	0

Bit 6: Uncontrolled Control Frame Reject (UCFR) When set to 1, Control Frames other than Pause Frames are allowed. When this bit is equal to zero, nonpause control frames are rejected.

Bit 5: Control Frame Reject (CFRR) When set to 1, control frames are allowed. When this bit is equal to zero, all control frames are rejected.

Bit 4: Length Error Reject (LERR) When set to 1, frames with an unmatched frame length field and actual number of bytes received are allowed. When equal to zero, only frames with matching length fields and actual bytes received will be allowed.

Bit 3: CRC Error Reject (CRCERR) When set to 1, frames received with a CRC error or MII error are allowed. When equal to zero, frames with CRC or MII errors are rejected.

Bit 2: Dribbling Bit Reject (DBR) When set to 1, frames with lengths of noninteger multiples of 8 bits are allowed. When equal to zero, frames with dribbling bits are rejected. The dribbling bit setting is only valid only if there is not a collision or runt frame.

Bit 1: MII Error Reject (MIIER) When set to 1, frames are allowed with MII Receive Errors. When equal to zero, frames with MII errors are rejected.

Bit 0: Broadcast Frame Reject (BFR) When set to 1, broadcast frames are allowed. When equal to zero, broadcast frames are rejected.

11.6.2 MAC Registers

The control Registers related to the control of the individual Mac's are shown in the following Table. The DS33R11 keeps statistics for the packet traffic sent and received. The register address map is shown in the following Table. Note that the addresses listed are the indirect addresses that must be provided to [SU.MACRADH/SU.MACRADL](#) or [SU.MACAWH/SU.MACAWL](#).

Register Name: **SU.MACCR**
 Register Description: **MAC Control Register**
 Register Address: **0000h (indirect)**

0000h:

Bit #	31	30	29	28	27	26	25	24
Name	Reserved	Reserved	Reserved	HDB	PS	Reserved	Reserved	Reserved
Default	0	0	0	0	0	0	0	0

0001h:

Bit #	23	22	21	20	19	18	17	16
Name	DRO	Reserved	OML0	F	PM	PAM	Reserved	Reserved
Default	0	0	0	0	0	0	0	0

0002h:

Bit #	15	14	13	12	11	10	09	08
Name	Reserved	Reserved	Reserved	LCC	Reserved	DRTY	Reserved	ASTP
Default	0	0	0	0	0	0	0	0

0003h:

Bit #	07	06	05	04	03	02	01	00
Name	BOLMT1	BOLMT0	DC	Reserved	TE	RE	Reserved	Reserved
Default	0	0	0	0	0	0	0	0

Bit 28: Heartbeat Disable (HDB) When set to 1, the heartbeat (SQE) function is disabled. This bit should be set to 1 when operating in MII mode.

Bit 27: Port Select (PS) This bit should be equal to 0 for proper operation.

Bit 23: Disable Receive Own (DRO) When set to 1, the MAC disables the reception of frames while TX_EN is asserted. When this bit equals zero, transmitted frames are also received by the MAC. This bit should be cleared when operating in full-duplex mode.

Bit 21: Loopback Operating Mode (OMLO) When set to 1, data is looped from the transmit side, back to the receive side, without being transmitted to the PHY.

Bit 20: Full-Duplex Mode Select (F) When set to 1, the MAC transmits and receives data simultaneously. When in full-duplex mode, the heartbeat check is disabled and the heartbeat fail status should be ignored.

Bit 19: Promiscuous Mode (PM) When set to 1, the MAC is in Promiscuous Mode and forwards all frames. Note that the default value is 1.

Bit 18: Pass All Multicast (PAM) When set to 1, the MAC forwards Multicast Frames.

Bit 12: Late Collision Control (LCC) When set to 1, enables retransmission of a collided packet even after the collision period. When this bit is clear, retransmission of late collisions is disabled.

Bit 10: Disable Retry (DRTY) When set to 1, the MAC makes only a single attempt to transmit each frame. If a collision occurs, the MAC ignores the current frame and proceeds to the next frame. When this bit equals 0, the MAC will retry collided packets 16 times before signaling a retry error.

Bit 8: Automatic Pad Stripping (ASTP) When set to 1, all incoming frames with less than 46 byte length are automatically stripped of the pad characters and FCS.

Bits 6 - 7: Back-Off Limit (BOLMT[0:1]) These two bits allow the user to set the back-off limit used for the maximum retransmission delay for collided packets. Default operation limits the maximum delay for retransmission to a countdown of 10 bits from a random number generator. The user can reduce the maximum number of counter bits as described in the table below. See IEEE 802.3 for details of the back-off algorithm.

Bit 7	Bit 6	Random Number Generator Bits Used
0	0	10
0	1	8
1	0	4
1	1	1

Bit 5: Deferral Check (DC) When set to 1, the MAC will abort packet transmission if it has deferred for more than 24,288 bit times. The deferral counter starts when the transmitter is ready to transmit a packet, but is prevented from transmission because CRS is active. If the MAC begins transmission but a collision occurs after the beginning of transmission, the deferral counter is reset again. If this bit is equal to zero, then the MAC will defer indefinitely.

Bit 3: Transmitter Enable (TE) When set to 1, packet transmission is enabled. When equal to zero, transmission is disabled.

Bit 2: Receiver Enable (RE) When set to 1, packet reception is enabled. When equal to zero, packets are not received.

Register Name: **SU.MACMIIA**
 Register Description: **MAC MII Management (MDIO) Address Register**
 Register Address: **0014h (indirect)**

0014h:

Bit #	31	30	29	28	27	26	25	24
Name	Reserved	Reserved	Reserved	Reserved	Reserved	Reserved	Reserved	Reserved
Default	0	0	0	0	0	0	0	0

0015h:

Bit #	23	22	21	20	19	18	17	16
Name	Reserved	Reserved	Reserved	Reserved	Reserved	Reserved	Reserved	Reserved
Default	0	0	0	0	0	0	0	0

0016h:

Bit #	15	14	13	12	11	10	09	08
Name	PHYA4	PHYA3	PHYA2	PHYA1	PHYA0	MIIA4	MIIA3	MIIA2
Default	0	1	0	1	1	0	1	0

0017h:

Bit #	07	06	05	04	03	02	01	00
Name	MIIA1	MIIA0	Reserved	Reserved	Reserved	Reserved	MIIW	MIIB
Default	1	1	0	0	0	0	0	0

Bits 11 - 15: PHY Address (PHYA[0:4]) These 5 bits select one of the 32 available PHY address locations to access through the PHY management (MDIO) bus.

Bits 6 - 10: MII Address (MIIA[0:4]) - These 5 bits are the address location within the PHY that is being accessed.

Bit 1: MII Write (MIIW) Write this bit to 1 in order to execute a write instruction over the MDIO interface. Write the bit to zero to execute a read instruction.

Bit 0: MII Busy (MIIW) This bit is set to 1 by the DS33R11 during execution of a MII management instruction through the MDIO interface, and is set to zero when the DS33R11 has completed the instruction. The user should read this bit and ensure that it is equal to zero prior to beginning a MDIO instruction.

Register Name: **SU.MACMIID**
 Register Description: **MAC MII (MDIO) Data Register**
 Register Address: **0018h (indirect)**

0018h:

Bit #	31	30	29	28	27	26	25	24
Name	Reserved	Reserved	Reserved	Reserved	Reserved	Reserved	Reserved	Reserved
Default	0	0	0	0	0	0	0	0

0019h:

Bit #	23	22	21	20	19	18	17	16
Name	Reserved	Reserved	Reserved	Reserved	Reserved	Reserved	Reserved	Reserved
Default	0	0	0	0	0	0	0	0

001Ah:

Bit #	15	14	13	12	11	10	09	08
Name	MIID15	MIID14	MIID13	MIID12	MIID11	MIID10	MIID09	MIID08
Default	0	0	0	0	0	0	0	0

001Bh:

Bit #	07	06	05	04	03	02	01	00
Name	MIID07	MIID06	MIID05	MIID04	MIID03	MIID02	MIID01	MIID00
Default	0	0	0	0	0	0	0	0

Bits 0 – 15: MII (MDIO) Data (MIID[00:15]) These two bytes contain the data to be written to or the data read from the MII management interface (MDIO).

Register Name: **SU.MACFCR**
 Register Description: **MAC Flow Control Register**
 Register Address: **001Ch (indirect)**

001Ch:

Bit #	31	30	29	28	27	26	25	24
Name	PT15	PT14	PT13	PT12	PT11	PT10	PT09	PT08
Default	0	0	0	0	0	0	0	0

001Dh:

Bit #	23	22	21	20	19	18	17	16
Name	PT07	PT06	PT05	PT04	PT03	PT02	PT01	PT00
Default	0	1	0	1	0	0	0	0

001Eh:

Bit #	15	14	13	12	11	10	09	08
Name	Reserved	Reserved	Reserved	Reserved	Reserved	Reserved	Reserved	Reserved
Default	0	0	0	0	0	0	0	0

001Fh:

Bit #	07	06	05	04	03	02	01	00
Name	Reserved	Reserved	Reserved	Reserved	Reserved	Reserved	FCE	FCB
Default	0	0	0	0	0	0	1	0

Bits 16 - 31: Pause Time (PT[00:15]) These bits are used for the Pause Time Field in transmitted Pause Frames. This value is the number of time slots the remote node should wait prior to transmission.

Bit 1: Flow Control Enable (FCE) When set to 1, the MAC automatically detects pause frames and will disable the transmitter for the requested pause time.

Bit 0: Flow Control Busy (FCB) The host can set this bit to 1 in order to initiate transmission of a pause frame. During transmission of a pause frame, this bit remains set. The DS33R11 will clear this bit when transmission of the pause frame has been completed. The user should read this bit and ensure that this bit is equal to zero prior to initiating a pause frame.

Register Name: **SU.MMCCTRL**
 Register Description: **MAC MMC Control Register**
 Register Address: **0100h (indirect)**

0100h:

Bit #	31	30	29	28	27	26	25	24
Name	Reserved	Reserved	Reserved	Reserved	Reserved	Reserved	Reserved	Reserved
Default	0	0	0	0	0	0	0	0

0101h:

Bit #	23	22	21	20	19	18	17	16
Name	Reserved	Reserved	Reserved	Reserved	Reserved	Reserved	Reserved	Reserved
Default	0	0	0	0	0	0	0	0

0102h:

Bit #	15	14	13	12	11	10	09	08
Name	Reserved	Reserved	MXFRM10	MXFRM9	MXFRM8	MXFRM7	MXFRM6	MXFRM5
Default	0	0	1	0	1	1	1	1

0103h:

Bit #	07	06	05	04	03	02	01	00
Name	MXFRM4	MXFRM3	MXFRM2	MXFRM1	MXFRM0	Reserved	Reserved	Reserved
Default	0	1	1	1	0	0	1	0

Bits 3 - 13: Maximum Frame Size (MXFRM[0:10]) These bits indicate the maximum packet size value. All transmitted frames larger than this value are counted as long frames.

Bit 1: Reserved - Note that this bit must be written to a "1" for proper operation.

Register Name: **Reserved**
 Register Description: **MAC Reserved Control Register**
 Register Address: **010Ch (indirect)**

010Ch:

Bit #	31	30	29	28	27	26	25	24
Name	Reserved	Reserved	Reserved	Reserved	Reserved	Reserved	Reserved	Reserved
Default	0	0	0	0	0	0	0	0

010Dh:

Bit #	23	22	21	20	19	18	17	16
Name	Reserved	Reserved	Reserved	Reserved	Reserved	Reserved	Reserved	Reserved
Default	0	0	0	0	0	0	0	0

010Eh:

Bit #	15	14	13	12	11	10	09	08
Name	Reserved	Reserved	Reserved	Reserved	Reserved	Reserved	Reserved	Reserved
Default	0	0	0	0	0	0	0	0

010Fh:

Bit #	07	06	05	04	03	02	01	00
Name	Reserved	Reserved	Reserved	Reserved	Reserved	Reserved	Reserved	Reserved
Default	0	0	0	0	0	0	0	0

Note – Addresses 10Ch through 10Fh must each be initialized with all 1's (FFh) for proper software-mode operation.

Register Name: **Reserved**
 Register Description: **MAC Reserved Control Register**
 Register Address: **0110h (indirect)**

0110h:

Bit #	31	30	29	28	27	26	25	24
Name	Reserved	Reserved	Reserved	Reserved	Reserved	Reserved	Reserved	Reserved
Default	0	0	0	0	0	0	0	0

0111h:

Bit #	23	22	21	20	19	18	17	16
Name	Reserved	Reserved	Reserved	Reserved	Reserved	Reserved	Reserved	Reserved
Default	0	0	0	0	0	0	0	0

0112h:

Bit #	15	14	13	12	11	10	09	08
Name	Reserved	Reserved	Reserved	Reserved	Reserved	Reserved	Reserved	Reserved
Default	0	0	0	0	0	0	0	0

0113h:

Bit #	07	06	05	04	03	02	01	00
Name	Reserved	Reserved	Reserved	Reserved	Reserved	Reserved	Reserved	Reserved
Default	0	0	0	0	0	0	0	0

Note – Addresses 110h through 113h must each be initialized with all 1's (FFh) for proper software-mode operation.

Register Name: **SU.RxFrmCtr**
 Register Description: **MAC All Frames Received Counter**
 Register Address: **0200h (indirect)**

0200h:

Bit #	31	30	29	28	27	26	25	24
Name	RXFRMC31	RXFRMC30	RXFRMC29	RXFRMC28	RXFRMC27	RXFRMC26	RXFRMC25	RXFRMC24
Default	0	0	0	0	0	0	0	0

0201h:

Bit #	23	22	21	20	19	18	17	16
Name	RXFRMC23	RXFRMC22	RXFRMC21	RXFRMC20	RXFRMC19	RXFRMC18	RXFRMC17	RXFRMC16
Default	0	0	0	0	0	0	0	0

0202h:

Bit #	15	14	13	12	11	10	09	08
Name	RXFRMC15	RXFRMC14	RXFRMC13	RXFRMC12	RXFRMC11	RXFRMC10	RXFRMC9	RXFRMC8
Default	0	0	0	0	0	0	0	0

0203h:

Bit #	07	06	05	04	03	02	01	00
Name	RXFRMC7	RXFRMC6	RXFRMC5	RXFRMC4	RXFRMC3	RXFRMC2	RXFRMC1	RXFRMC0
Default	0	0	0	0	0	0	0	0

Bits 0 - 31: All Frames Received Counter (RXFRMC[0:31]) 32 bit value indicating the number of frames received. Each time a frame is received, this counter is incremented by 1. This counter resets only upon device reset, does not saturate, and rolls-over to zero upon reaching the maximum value. The user should ensure that the measurement period is less than the minimum length of time required for the counter to increment $2^{32}-1$ times at the maximum frame rate. The user should store the value from the beginning of the measurement period for later calculations, and take into account the possibility of a roll-over to occurring.

Register Name: **SU.RxFrmOkCtr**
 Register Description: **MAC Frames Received OK Counter**
 Register Address: **0204h (indirect)**

0204h:

Bit #	31	30	29	28	27	26	25	24
Name	RXFRMOK31	RXFRMOK30	RXFRMOK29	RXFRMOK28	RXFRMOK27	RXFRMOK26	RXFRMOK25	RXFRMOK24
Default	0	0	0	0	0	0	0	0

0205h:

Bit #	23	22	21	20	19	18	17	16
Name	RXFRMOK23	RXFRMOK22	RXFRMOK21	RXFRMOK20	RXFRMOK19	RXFRMOK18	RXFRMOK17	RXFRMOK16
Default	0	0	0	0	0	0	0	0

0206h:

Bit #	15	14	13	12	11	10	09	08
Name	RXFRMOK15	RXFRMOK14	RXFRMOK13	RXFRMOK12	RXFRMOK11	RXFRMOK10	RXFRMOK9	RXFRMOK8
Default	0	0	0	0	0	0	0	0

0207h:

Bit #	07	06	05	04	03	02	01	00
Name	RXFRMOK7	RXFRMOK6	RXFRMOK5	RXFRMOK4	RXFRMOK3	RXFRMOK2	RXFRMOK1	RXFRMOK0
Default	0	0	0	0	0	0	0	0

Bits 0 - 31: Frames Received OK Counter (RXFRMOK[0:31]) 32 bit value indicating the number of frames received and determined to be valid. Each time a valid frame is received, this counter is incremented by 1. This counter resets only upon device reset, does not saturate, and rolls-over to zero upon reaching the maximum value. The user should ensure that the measurement period is less than the minimum length of time required for the counter to increment $2^{32}-1$ times at the maximum frame rate. The user should store the value from the beginning of the measurement period for later calculations, and take into account the possibility of a roll-over to occurring.

Register Name: **SU.TxFrmCtr**
 Register Description: **MAC All Frames Transmitted Counter**
 Register Address: **0300h (indirect)**

0300h:

Bit #	31	30	29	28	27	26	25	24
Name	TXFRMC31	TXFRMC30	TXFRMC29	TXFRMC28	TXFRMC27	TXFRMC26	TXFRMC25	TXFRMC24
Default	0	0	0	0	0	0	0	0

0301h:

Bit #	23	22	21	20	19	18	17	16
Name	TXFRMC23	TXFRMC22	TXFRMC21	TXFRMC20	TXFRMC19	TXFRMC18	TXFRMC17	TXFRMC16
Default	0	0	0	0	0	0	0	0

0302h:

Bit #	15	14	13	12	11	10	09	08
Name	TXFRMC15	TXFRMC14	TXFRMC13	TXFRMC12	TXFRMC11	TXFRMC10	TXFRMC9	TXFRMC8
Default	0	0	0	0	0	0	0	0

0303h:

Bit #	07	06	05	04	03	02	01	00
Name	TXFRMC7	TXFRMC6	TXFRMC5	TXFRMC4	TXFRMC3	TXFRMC2	TXFRMC1	TXFRMC0
Default	0	0	0	0	0	0	0	0

Bits 0 - 31: All Frames Transmitted Counter (TXFRMC[0:31]) 32 bit value indicating the number of frames transmitted. Each time a frame is transmitted, this counter is incremented by 1. This counter resets only upon device reset, does not saturate, and rolls-over to zero upon reaching the maximum value. The user should ensure that the measurement period is less than the minimum length of time required for the counter to increment $2^{32}-1$ times at the maximum frame rate. The user should store the value from the beginning of the measurement period for later calculations, and take into account the possibility of a roll-over to occurring.

Register Name: **SU.TxBytesCtr**
 Register Description: **MAC All Bytes Transmitted Counter**
 Register Address: **0308h (indirect)**

0308h:

Bit #	31	30	29	28	27	26	25	24
Name	TXBYTEC31	TXBYTEC30	TXBYTEC29	TXBYTEC28	TXBYTEC27	TXBYTEC26	TXBYTEC25	TXBYTEC24
Default	0	0	0	0	0	0	0	0

0309h:

Bit #	23	22	21	20	19	18	17	16
Name	TXBYTEC23	TXBYTEC22	TXBYTEC21	TXBYTEC20	TXBYTEC19	TXBYTEC18	TXBYTEC17	TXBYTEC16
Default	0	0	0	0	0	0	0	0

030Ah:

Bit #	15	14	13	12	11	10	09	08
Name	TXBYTEC15	TXBYTEC14	TXBYTEC13	TXBYTEC12	TXBYTEC11	TXBYTEC10	TXBYTEC9	TXBYTEC8
Default	0	0	0	0	0	0	0	0

030Bh:

Bit #	07	06	05	04	03	02	01	00
Name	TXBYTEC7	TXBYTEC6	TXBYTEC5	TXBYTEC4	TXBYTEC3	TXBYTEC2	TXBYTEC1	TXBYTEC0
Default	0	0	0	0	0	0	0	0

Bits 0 - 31: All Bytes Transmitted Counter (TXBYTEC[0:31]) 32 bit value indicating the number of bytes transmitted. Each time a byte is transmitted, this counter is incremented by 1. This counter resets only upon device reset, does not saturate, and rolls-over to zero upon reaching the maximum value. The user should ensure that the measurement period is less than the minimum length of time required for the counter to increment $2^{32}-1$ times at the maximum data rate. The user should store the value from the beginning of the measurement period for later calculations, and take into account the possibility of a roll-over to occurring.

Register Name: **SU.TxBytesOkCtr**
 Register Description: **MAC Bytes Transmitted OK Counter**
 Register Address: **030Ch (indirect)**

030Ch:

Bit #	31	30	29	28	27	26	25	24
Name	TXBYTEOK31	TXBYTEOK30	TXBYTEOK29	TXBYTEOK28	TXBYTEOK27	TXBYTEOK26	TXBYTEOK25	TXBYTEOK24
Default	0	0	0	0	0	0	0	0

030Dh:

Bit #	23	22	21	20	19	18	17	16
Name	TXBYTEOK23	TXBYTEOK22	TXBYTEOK21	TXBYTEOK20	TXBYTEOK19	TXBYTEOK18	TXBYTEOK17	TXBYTEOK16
Default	0	0	0	0	0	0	0	0

030Eh:

Bit #	15	14	13	12	11	10	09	08
Name	TXBYTEOK15	TXBYTEOK14	TXBYTEOK13	TXBYTEOK12	TXBYTEOK11	TXBYTEOK10	TXBYTEOK9	TXBYTEOK8
Default	0	0	0	0	0	0	0	0

030Fh:

Bit #	07	06	05	04	03	02	01	00
Name	TXBYTEOK7	TXBYTEOK6	TXBYTEOK5	TXBYTEOK4	TXBYTEOK3	TXBYTEOK2	TXBYTEOK1	TXBYTEOK0
Default	0	0	0	0	0	0	0	0

Bits 0 - 31: Bytes Transmitted OK Counter (TXBYTEOK[0:31]) 32 bit value indicating the number of bytes transmitted and determined to be valid. Each time a valid byte is transmitted, this counter is incremented by 1. This counter resets only upon device reset, does not saturate, and rolls-over to zero upon reaching the maximum value. The user should ensure that the measurement period is less than the minimum length of time required for the counter to increment $2^{32}-1$ times at the maximum frame rate. The user should store the value from the beginning of the measurement period for later calculations, and take into account the possibility of a roll-over to occurring.

Register Name: **SU.TxFrmUndr**
 Register Description: **MAC Transmit Frame Under Run Counter**
 Register Address: **0334h (indirect)**

0334h:

Bit #	31	30	29	28	27	26	25	24
Name	TXFRMU31	TXFRMU30	TXFRMU29	TXFRMU28	TXFRMU27	TXFRMU26	TXFRMU25	TXFRMU24
Default	0	0	0	0	0	0	0	0

0335h:

Bit #	23	22	21	20	19	18	17	16
Name	TXFRMU23	TXFRMU22	TXFRMU21	TXFRMU20	TXFRMU19	TXFRMU18	TXFRMU17	TXFRMU16
Default	0	0	0	0	0	0	0	0

0336h:

Bit #	15	14	13	12	11	10	09	08
Name	TXFRMU15	TXFRMU14	TXFRMU13	TXFRMU12	TXFRMU11	TXFRMU10	TXFRMU9	TXFRMU8
Default	0	0	0	0	0	0	0	0

0337h:

Bit #	07	06	05	04	03	02	01	00
Name	TXFRMU7	TXFRMU6	TXFRMU5	TXFRMU4	TXFRMU3	TXFRMU2	TXFRMU1	TXFRMU0
Default	0	0	0	0	0	0	0	0

Bits 0 - 31: Frames Aborted Due to FIFO Under Run Counter (TXFRMU[0:31]) 32 bit value indicating the number of frames aborted due to FIFO under run. Each time a frame is aborted due to FIFO under run, this counter is incremented by 1. This counter resets only upon device reset, does not saturate, and rolls-over to zero upon reaching the maximum value. The user should ensure that the measurement period is less than the minimum length of time required for the counter to increment $2^{32}-1$ times at the maximum frame rate. The user should store the value from the beginning of the measurement period for later calculations, and take into account the possibility of a roll-over to occurring.

Register Name: **SU.TxBdFrmCtr**
 Register Description: **MAC All Frames Aborted Counter**
 Register Address: **0338h (indirect)**

0338h:

Bit #	31	30	29	28	27	26	25	24
Name	TXFRMBD31	TXFRMBD30	TXFRMBD29	TXFRMBD28	TXFRMBD27	TXFRMBD26	TXFRMBD25	TXFRMBD24
Default	0	0	0	0	0	0	0	0

0339h:

Bit #	23	22	21	20	19	18	17	16
Name	TXFRMBD23	TXFRMBD22	TXFRMBD21	TXFRMBD20	TXFRMBD19	TXFRMBD18	TXFRMBD17	TXFRMBD16
Default	0	0	0	0	0	0	0	0

033Ah:

Bit #	15	14	13	12	11	10	09	08
Name	TXFRMBD15	TXFRMBD14	TXFRMBD13	TXFRMBD12	TXFRMBD11	TXFRMBD10	TXFRMBD9	TXFRMBD8
Default	0	0	0	0	0	0	0	0

033Bh:

Bit #	07	06	05	04	03	02	01	00
Name	TXFRMBD7	TXFRMBD6	TXFRMBD5	TXFRMBD4	TXFRMBD3	TXFRMBD2	TXFRMBD1	TXFRMBD0
Default	0	0	0	0	0	0	0	0

Bits 0 to 31: All Frames Aborted Counter (TXFRMBD[0:31]) 32 bit value indicating the number of frames aborted due to any reason. Each time a frame is aborted, this counter is incremented by 1. This counter resets only upon device reset, does not saturate, and rolls-over to zero upon reaching the maximum value. The user should ensure that the measurement period is less than the minimum length of time required for the counter to increment $2^{32}-1$ times at the maximum frame rate. The user should store the value from the beginning of the measurement period for later calculations, and take into account the possibility of a roll-over to occurring.

11.7 T1/E1/J1 Transceiver Registers

Register Name: **TR.MSTRREG**
 Register Description: **Master Mode Register**
 Register Address: **00h**

Bit #	7	6	5	4	3	2	1	0
Name	—	—	—	—	TEST1	TEST0	T1/E1	SFTRST
Default	0	0	0	0	0	0	0	0

Bits 2 – 3: Test Mode Bits (TEST0, TEST1) Test modes are used to force the output pins of the transceiver into known states. This can facilitate the checkout of assemblies during the manufacturing process and also be used to isolate devices from shared buses.

TEST1	TEST0	Effect On Output Pins
0	0	Operate normally
0	1	Force all output pins into tri-state (including all I/O pins and parallel port pins)
1	0	Force all output pins low (including all I/O pins except parallel port pins)
1	1	Force all output pins high (including all I/O pins except parallel port pins)

Bit 1: Transceiver Operating Mode (T1/E1) Used to select the operating mode of the framer/formatter (digital) portion of the Transceiver. The operating mode of the LIU must also be programmed.

0 = T1 operation

1 = E1 operation

Bit 0: Software-Issued Reset (SFTRST) A 0-to-1 transition causes the register space in the T1/E1/J1 transceiver to be cleared. A reset clears all configuration and status registers. The bit automatically clears itself when the reset has completed.

Register Name: **TR.IOCR1**
 Register Description: **I/O Configuration Register 1**
 Register Address: **01h**

Bit #	7	6	5	4	3	2	1	0
Name	RSMS	RSMS2	RSMS1	RSIO	TSDW	TSM	TSIO	ODF
Default	0	0	0	0	0	0	0	0

Bit 7: RSYNC Multiframe Skip Control (RSMS) Useful in framing format conversions from D4 to ESF. This function is not available when the receive-side elastic store is enabled. RSYNC must be set to output multiframe pulses (TR.IOCR1.5 = 1 and TR.IOCR1.4 = 0).

- 0 = RSYNC outputs a pulse at every multiframe
- 1 = RSYNC outputs a pulse at every other multiframe

Bit 6: RSYNC Mode Select 2 (RSMS2)

T1 Mode: RSYNC pin must be programmed in the output frame mode (TR.IOCR1.5 = 0, TR.IOCR1.4 = 0).

- 0 = do not pulse double-wide in signaling frames
- 1 = do pulse double-wide in signaling frames

E1 Mode: RSYNC pin must be programmed in the output multiframe mode (TR.IOCR1.5 = 1, TR.IOCR1.4 = 0).

- 0 = RSYNC outputs CAS multiframe boundaries
- 1 = RSYNC outputs CRC4 multiframe boundaries

Bit 5: RSYNC Mode Select 1 (RSMS1) Selects frame or multiframe pulse when RSYNC pin is in output mode. In input mode (elastic store must be enabled), multiframe mode is only useful when receive signaling reinsertion is enabled. See the timing diagrams in Section [12](#).

- 0 = frame mode
- 1 = multiframe mode

Bit 4: RSYNC I/O Select (RSIO) (Note: This bit must be set to 0 when TR.ESCR.0 = 0.)

- 0 = RSYNC is an output
- 1 = RSYNC is an input (only valid if elastic store enabled)

Bit 3: TSYNC Double-Wide (TSDW) (Note: This bit must be set to 0 when TR.IOCR1.2 = 1 or when TR.IOCR1.1 = 0.)

- 0 = do not pulse double-wide in signaling frames
- 1 = do pulse double-wide in signaling frames

Bit 2: TSYNC Mode Select (TSM) Selects frame or multiframe mode for the TSYNC pin. See the timing diagrams in Section [12](#).

- 0 = frame mode
- 1 = multiframe mode

Bit 1: TSYNC I/O Select (TSIO)

- 0 = TSYNC is an input
- 1 = TSYNC is an output

Bit 0: Output Data Format (ODF)

- 0 = bipolar data at TPOSO and TNEGO
- 1 = NRZ data at TPOSO; TNEGO = 0

Register Name: **TR.IOCR2**
 Register Description: **I/O Configuration Register 2**
 Register Address: **02h**

Bit #	7	6	5	4	3	2	1	0
Name	RCLKINV	TCLKINV	RSYNCINV	TSYNCINV	TSSYNCINV	H100EN	TSCLKM	RSCLKM
Default	0	0	0	0	0	0	0	0

Bit 7: RCLKO Invert (RCLKINV)

0 = no inversion
 1 = inverts signal on RCLKO output.

Bit 6: TCLKT Invert (TCLKINV)

0 = no inversion
 1 = inverts signal on TCLKT input.

Bit 5: RSYNC Invert (RSYNCINV)

0 = no inversion
 1 = invert

Bit 4: TSYNC Invert (TSYNCINV)

0 = no inversion
 1 = invert

Bit 3: TSSYNC Invert (TSSYNCINV)

0 = no inversion
 1 = invert

Bit 2 : H.100 SYNC Mode (H100EN)

0 = normal operation
 1 = SYNC shift

Bit 1: TSYCLK Mode Select (TSCLKM)

0 = if TSYCLK is 1.544MHz
 1 = if TSYCLK is 2.048MHz

Bit 0: RSYCLK Mode Select (RSCLKM)

0 = if RSYCLK is 1.544MHz
 1 = if RSYCLK is 2.048MHz

Register Name: **TR.T1RCR1**
 Register Description: **T1 Receive Control Register 1**
 Register Address: **03h**

Bit #	7	6	5	4	3	2	1	0
Name	—	ARC	OOF1	OOF2	SYNCC	SYNCT	SYNCE	RESYNC
Default	0	0	0	0	0	0	0	0

Bit 6: Auto Resync Criteria (ARC)

0 = resync on OOF or RCL event

1 = resync on OOF only

Bits 4- 5: Out-of-Frame Select Bits (OOF2, OOF1)

OOF2	OOF1	Out-Of-Frame Criteria
0	0	2/4 frame bits in error
0	1	2/5 frame bits in error
1	0	2/6 frame bits in error
1	1	2/6 frame bits in error

Bit 3: Sync Criteria (SYNCC)

In D4 Framing Mode:

0 = search for Ft pattern, then search for Fs pattern

1 = cross couple Ft and Fs pattern

In ESF Framing Mode:

0 = search for FPS pattern only

1 = search for FPS and verify with CRC6

Bit 2: Sync Time (SYNCT)

0 = qualify 10 bits

1 = qualify 24 bits

Bit 1: Sync Enable (SYNCE)

0 = auto resync enabled

1 = auto resync disabled

Bit 0: Resynchronize (RESYNC) When toggled from low to high, a resynchronization of the receive-side framer is initiated. Must be cleared and set again for a subsequent resync.

Register Name: **TR.T1RCR2**
 Register Description: **T1 Receive Control Register 2**
 Register Address: **04h**

Bit #	7	6	5	4	3	2	1	0
Name	—	RFM	RB8ZS	RSLC96	RZSE	—	RJC	RD4YM
Default	0	0	0	0	0	0	0	0

Bit 6: Receive Frame Mode Select (RFM)

0 = D4 framing mode
 1 = ESF framing mode

Bit 5: Receive B8ZS Enable (RB8ZS)

0 = B8ZS disabled
 1 = B8ZS enabled

Bit 4: Receive SLC-96 Enable (RSLC96). Only set this bit to a 1 in D4/SLC-96 framing applications. See Section [10.18](#) for details.

0 = SLC-96 disabled
 1 = SLC-96 enabled

Bit 3: Receive FDL Zero-Destuffer Enable (RZSE). Set this bit to 0 if using the internal HDLC/BOC controller instead of the legacy support for the FDL. See Section [10.17](#) for details.

0 = zero destuffer disabled
 1 = zero destuffer enabled

Bit 2: Reserved. Set to zero for proper operation.

Bit 1: Receive Japanese CRC6 Enable (RJC)

0 = use ANSI/AT&T/ITU CRC6 calculation (normal operation)
 1 = use Japanese standard JT-G704 CRC6 calculation

Bit 0: Receive-Side D4 Yellow Alarm Select (RD4YM)

0 = 0s in bit 2 of all channels
 1 = a 1 in the S-bit position of frame 12 (J1 Yellow Alarm Mode)

Register Name: **TR.T1TCR1**
 Register Description: **T1 Transmit Control Register 1**
 Register Address: **05h**

Bit #	7	6	5	4	3	2	1	0
Name	TJC	TFPT	TCPT	TSSE	GB7S	TFDLS	TBL	TYEL
Default	0	0	0	0	0	0	0	0

Bit 7: Transmit Japanese CRC6 Enable (TJC)

0 = use ANSI/AT&T/ITU CRC6 calculation (normal operation)
 1 = use Japanese standard JT-G704 CRC6 calculation

Bit 6: Transmit F-Bit Pass-Through (TFPT)

0 = F bits sourced internally
 1 = F bits sampled at TSER1

Bit 5: Transmit CRC Pass-Through (TCPT)

0 = source CRC6 bits internally
 1 = CRC6 bits sampled at TSER1 during F-bit time

Bit 4: Transmit Software Signaling Enable (TSSE).

0 = do not source signaling data from the TR.TSx registers regardless of the TR.SSIEEx registers. The TR.SSIEEx registers still define which channels are to have B7 stuffing preformed.
 1 = source signaling data as enabled by the TR.SSIEEx registers

Bit 3: Global Bit 7 Stuffing (GB7S)

0 = allow the SSIEEx registers to determine which channels containing all 0s are to be bit 7 stuffed
 1 = force bit 7 stuffing in all 0-byte channels regardless of how the TR.SSIEEx registers are programmed

Bit 2: TFDL Register Select (TFDLS)

0 = source FDL or Fs-bits from the internal TR.TFDL register (legacy FDL support mode)
 1 = source FDL or Fs-bits from the internal HDLC controller

Bit 1: Transmit Blue Alarm (TBL)

0 = transmit data normally
 1 = transmit an unframed all-ones code at TPOS and TNEG

Bit 0: Transmit Yellow Alarm (TYEL)

0 = do not transmit yellow alarm
 1 = transmit yellow alarm

Register Name: **TR.T1TCR2**
 Register Description: **T1 Transmit Control Register 2**
 Register Address: **06h**

Bit #	7	6	5	4	3	2	1	0
Name	TB8ZS	TSLC96	TZSE	FBCT2	FBCT1	TD4YM	—	TB7ZS
Default	0	0	0	0	0	0	0	0

Bit 7: Transmit B8ZS Enable (TB8ZS)

0 = B8ZS disabled
 1 = B8ZS enabled

Bit 6: Transmit SLC-96/Fs-Bit Insertion Enable (TSLC96). Only set this bit to a 1 in D4 framing applications. Must be set to 1 to source the Fs pattern from the TR.TFDL register. See Section [10.18](#) for details.

0 = SLC-96/Fs-bit insertion disabled
 1 = SLC-96/Fs-bit insertion enabled

Bit 5: Transmit FDL Zero-Stuffer Enable (TZSE). Set this bit to 0 if using the internal HDLC controller instead of the legacy support for the FDL. See Section 15 for details.

0 = zero stuffer disabled
 1 = zero stuffer enabled

Bit 4: F-Bit Corruption Type 2 (FBCT2). Setting this bit high enables the corruption of one Ft (D4 framing mode) or FPS (ESF framing mode) bit in every 128 Ft or FPS bits as long as the bit remains set.

Bit 3: F-Bit Corruption Type 1 (FBCT1). A low-to-high transition of this bit causes the next three consecutive Ft (D4 framing mode) or FPS (ESF framing mode) bits to be corrupted causing the remote end to experience a loss of synchronization.

Bit 2: Transmit-Side D4 Yellow Alarm Select (TD4YM)

0 = 0s in bit 2 of all channels
 1 = a 1 in the S-bit position of frame 12

Bit 0: Transmit-Side Bit 7 Zero-Suppression Enable (TB7ZS)

0 = no stuffing occurs
 1 = bit 7 forced to a 1 in channels with all 0s

Register Name: **TR.T1CCR1**
 Register Description: **T1 Common Control Register 1**
 Register Address: **07h**

Bit #	7	6	5	4	3	2	1	0
Name	—	—	—	TRAI-CI	TAIS-CI	TFM	PDE	TLOOP
Default	0	0	0	0	0	0	0	0

Bit 4: Transmit RAI-CI Enable (TRAI-CI). Setting this bit causes the ESF RAI-CI code to be transmitted in the FDL bit position.

- 0 = do not transmit the ESF RAI-CI code
- 1 = transmit the ESF RAI-CI code

Bit 3: Transmit AIS-CI Enable (TAIS-CI). Setting this bit and the TBL bit (TR.T1TCR1.1) causes the AIS-CI code to be transmitted at TPOSO and TNEGO, as defined in ANSI T1.403.

- 0 = do not transmit the AIS-CI code
- 1 = transmit the AIS-CI code (TR.T1TCR1.1 must also be set = 1)

Bit 2: Transmit Frame Mode Select (TFM)

- 0 = D4 framing mode
- 1 = ESF framing mode

Bit 1: Pulse Density Enforcer Enable (PDE). The framer always examines the transmit and receive data streams for violations of these, which are required by ANSI T1.403: No more than 15 consecutive 0s and at least N 1s in each and every time window of $8 \times (N + 1)$ bits, where N = 1 through 23. Violations for the transmit and receive data streams are reported in the TR.INFO1.6 and TR.INFO1.7 bits, respectively. When this bit is set to 1, the T1/E1/J1 transceiver forces the transmitted stream to meet this requirement no matter the content of the transmitted stream. When running B8ZS, this bit should be set to 0 since B8ZS encoded data streams cannot violate the pulse density requirements.

- 0 = disable transmit pulse density enforcer
- 1 = enable transmit pulse density enforcer

Bit 0: Transmit Loop-Code Enable (TLOOP). See Section [10.19](#) for details.

- 0 = transmit data normally
- 1 = replace normal transmitted data with repeating code as defined in registers TR.TCD1 and TR.TCD2

Register Name: **TR.SSIE1 (T1 Mode)**
 Register Description: **Software Signaling Insertion Enable 1**
 Register Address: **08h**

Bit #	7	6	5	4	3	2	1	0
Name	CH8	CH7	CH6	CH5	CH4	CH3	CH2	CH1
Default	0	0	0	0	0	0	0	0

Bits 0 – 7: Software Signaling Insertion Enable for Channels 1 to 8 (CH1 to CH8). These bits determine which channels are to have signaling inserted from the transmit signaling registers.

- 0 = do not source signaling data from the TR.TSx registers for this channel
- 1 = source signaling data from the TR.TSx registers for this channel

Register Name: **TR.SSIE1 (E1 Mode)**
 Register Description: **Software Signaling Insertion Enable 1**
 Register Address: **08h**

Bit #	7	6	5	4	3	2	1	0
Name	CH7	CH6	CH5	CH4	CH3	CH2	CH1	UCAW
Default	0	0	0	0	0	0	0	0

Bits 1 – 7: Software Signaling-Insertion Enable for Channels 1 to 7 (CH1 to CH7). These bits determine which channels are to have signaling inserted from the transmit signaling registers.

0 = do not source signaling data from the TR.TSx registers for this channel

1 = source signaling data from the TR.TSx registers for this channel

Bit 0: Upper CAS Align/Alarm Word (UCAW). Selects the upper CAS align/alarm pattern (0000) to be sourced from the upper 4 bits of the TS1 register.

0 = do not source the upper CAS align/alarm pattern from the TR.TS1 register

1 = source the upper CAS align/alarm pattern from the TR.TS1 register

Register Name: **TR.SSIE2 (T1 Mode)**
 Register Description: **Software Signaling-Insertion Enable 2**
 Register Address: **09h**

Bit #	7	6	5	4	3	2	1	0
Name	CH16	CH15	CH14	CH13	CH12	CH11	CH10	CH9
Default	0	0	0	0	0	0	0	0

Bits 0 – 7: Software Signaling Insertion Enable for Channels 9 to 16 (CH9 to CH16). These bits determine which channels are to have signaling inserted from the transmit signaling registers.

0 = do not source signaling data from the TR.TSx registers for this channel

1 = source signaling data from the TR.TSx registers for this channel

Register Name: **TR.SSIE2 (E1 Mode)**
 Register Description: **Software Signaling Insertion Enable 2**
 Register Address: **09h**

Bit #	7	6	5	4	3	2	1	0
Name	CH15	CH14	CH13	CH12	CH11	CH10	CH9	CH8
Default	0	0	0	0	0	0	0	0

Bits 0 – 7: Software Signaling Insertion Enable for Channels 8 to 15 (CH8 to CH15). These bits determine which channels are to have signaling inserted from the transmit signaling registers.

0 = do not source signaling data from the TR.TSx registers for this channel

1 = source signaling data from the TR.TSx registers for this channel

Register Name: **TR.SSIE3 (T1 Mode)**
 Register Description: **Software Signaling-Insertion Enable 3**
 Register Address: **0Ah**

Bit #	7	6	5	4	3	2	1	0
Name	CH24	CH23	CH22	CH21	CH20	CH19	CH18	CH17
Default	0	0	0	0	0	0	0	0

Bits 0 – 7: Software Signaling Insertion Enable for Channels 17 to 24 (CH17 to CH24). These bits determine which channels are to have signaling inserted from the transmit signaling registers.

0 = do not source signaling data from the TR.TSx registers for this channel

1 = source signaling data from the TR.TSx registers for this channel

Register Name: **TR.SSIE3 (E1 Mode)**
 Register Description: **Software Signaling Insertion Enable 3**
 Register Address: **0Ah**

Bit #	7	6	5	4	3	2	1	0
Name	CH22	CH21	CH20	CH19	CH18	CH17	CH16	LCAW
Default	0	0	0	0	0	0	0	0

Bits 1 – 7: Software Signaling Insertion Enable for LCAW and Channels 16 to 22 (CH16 to CH22). These bits determine which channels are to have signaling inserted from the transmit signaling registers.

0 = do not source signaling data from the TR.TSx registers for this channel

1 = source signaling data from the TR.TSx registers for this channel

Bit 0: Lower CAS Align/Alarm Word (LCAW). Selects the lower CAS align/alarm bits (xyxx) to be sourced from the lower 4 bits of the TS1 register.

0 = do not source the lower CAS align/alarm bits from the TR.TS1 register

1 = source the lower CAS alarm align/bits from the TR.TS1 register

Register Name: **TR.SSIE4**
 Register Description: **Software Signaling Insertion Enable 4**
 Register Address: **0Bh**

Bit #	7	6	5	4	3	2	1	0
Name	CH30	CH29	CH28	CH27	CH26	CH25	CH24	CH23
Default	0	0	0	0	0	0	0	0

Bits 0 – 7: Software Signaling Insertion Enable for Channels 22 to 30 (CH23 to CH30). These bits determine which channels are to have signaling inserted from the transmit signaling registers.

0 = do not source signaling data from the TR.TSx registers for this channel

1 = source signaling data from the TR.TSx registers for this channel

Register Name: **TR.T1RDMR1**
 Register Description: **T1 Receive Digital-Milliwatt Enable Register 1**
 Register Address: **0Ch**

Bit #	7	6	5	4	3	2	1	0
Name	CH8	CH7	CH6	CH5	CH4	CH3	CH2	CH1
Default	0	0	0	0	0	0	0	0

Bits 0 - 7: Receive Digital-Milliwatt Enable for Channels 1 to 8 (CH1 to CH8)

0 = do not affect the receive data associated with this channel

1 = replace the receive data associated with this channel with digital-milliwatt code

Register Name: **TR.T1RDMR2**
 Register Description: **T1 Receive Digital-Milliwatt Enable Register 2**
 Register Address: **0Dh**

Bit #	7	6	5	4	3	2	1	0
Name	CH16	CH15	CH14	CH13	CH12	CH11	CH10	CH9
Default	0	0	0	0	0	0	0	0

Bits 0 - 7: Receive Digital-Milliwatt Enable for Channels 9 to 16 (CH9 to CH16)

0 = do not affect the receive data associated with this channel

1 = replace the receive data associated with this channel with digital-milliwatt code

Register Name: **TR.T1RDMR3**
 Register Description: **T1 Receive Digital-Milliwatt Enable Register 3**
 Register Address: **0Eh**

Bit #	7	6	5	4	3	2	1	0
Name	CH24	CH23	CH22	CH21	CH20	CH19	CH18	CH17
Default	0	0	0	0	0	0	0	0

Bits 0 - 7: Receive Digital-Milliwatt Enable for Channels 17 to 24 (CH17 to CH24)

0 = do not affect the receive data associated with this channel

1 = replace the receive data associated with this channel with digital-milliwatt code

Register Name: **TR.IDR**
 Register Description: **Device Identification Register**
 Register Address: **0Fh**

Bit #	7	6	5	4	3	2	1	0
Name	ID7	ID6	ID5	ID4	ID3	ID2	ID1	ID0
Default	1	0	1	1	X	X	X	X

Bits 4 - 7: Device ID (ID4 to ID7). The upper four bits of TR.IDR are used to display the transceiver ID.

Bits 0 – 3: Chip Revision Bits (ID0 to ID3). The lower four bits of TR.IDR are used to display the die revision of the chip. ID0 is the LSB of a decimal code that represents the chip revision.

Register Name: **TR.INFO1**
 Register Description: **Information Register 1**
 Register Address: **10h**

Bit #	7	6	5	4	3	2	1	0
Name	RPDV	TPDV	COFA	8ZD	16ZD	SEFE	B8ZS	FBE
Default	0	0	0	0	0	0	0	0

Bit 7: Receive Pulse-Density Violation Event (RPDV). Set when the receive data stream does not meet the ANSI T1.403 requirements for pulse density.

Bit 6: Transmit Pulse-Density Violation Event (TPDV). Set when the transmit data stream does not meet the ANSI T1.403 requirements for pulse density.

Bit 5: Change-of-Frame Alignment Event (COFA). Set when the last resync resulted in a change-of-frame or multiframe alignment.

Bit 4: Eight Zero-Detect Event (8ZD). Set when a string of at least eight consecutive 0s (regardless of the length of the string) have been received at RPOSI and RNEGI.

Bit 3: Sixteen Zero-Detect Event (16ZD). Set when a string of at least 16 consecutive 0s (regardless of the length of the string) have been received at RPOSI and RNEGI.

Bit 2: Severely Errored Framing Event (SEFE). Set when two out of six framing bits (Ft or FPS) are received in error.

Bit 1: B8ZS Codeword Detect Event (B8ZS). Set when a B8ZS codeword is detected at RPOS and RNEG independent of whether the B8ZS mode is selected or not by TR.T1TCR2.7. Useful for automatically setting the line coding.

Bit 0: Frame Bit-Error Event (FBE). Set when an Ft (D4) or FPS (ESF) framing bit is received in error.

Register Name: **TR.INFO2**
 Register Description: **Information Register 2**
 Register Address: **11h**

Bit #	7	6	5	4	3	2	1	0
Name	BSYNC	BD	TCLE	TOCD	RL3	RL2	RL1	RL0
Default	0	0	0	0	0	0	0	0

Bit 7: BERT Real-Time Synchronization Status (BSYNC). Real-time status of the synchronizer (this bit is not latched). This bit is set when the incoming pattern matches for 32 consecutive bit positions. It is cleared when six or more bits out of 64 are received in error. Refer to BSYNC in the BERT status register, TR.SR9, for an interrupt-generating version of this signal.

Bit 6: BOC Detected (BD). A real-time bit that is set high when the BOC detector is presently seeing a valid sequence and set low when no BOC is currently being detected.

Bit 5: Transmit Current-Limit Exceeded (TCLE). A real-time bit that is set when the 50mA (RMS) current limiter is activated, whether the current limiter is enabled or not.

Bit 4: Transmit Open-Circuit Detect (TOCD). A real-time bit that is set when the device detects that the TTIP and TRING outputs are open-circuited.

Bits 0 – 3: Receive Level Bits (RL0 to RL3). Real-time bits

RL3	RL2	RL1	RL0	Receive Level (dB)
0	0	0	0	Greater than -2.5
0	0	0	1	-2.5 to -5.0
0	0	1	0	-5.0 to -7.5
0	0	1	1	-7.5 to -10.0
0	1	0	0	-10.0 to -12.5
0	1	0	1	-12.5 to -15.0
0	1	1	0	-15.0 to -17.5
0	1	1	1	-17.5 to -20.0
1	0	0	0	-20.0 to -22.5
1	0	0	1	-22.5 to -25.0
1	0	1	0	-25.0 to -27.5
1	0	1	1	-27.5 to -30.0
1	1	0	0	-30.0 to -32.5
1	1	0	1	-32.5 to -35.0
1	1	1	0	-35.0 to -37.5
1	1	1	1	Less than -37.5

NOTE: RL0 through RL3 only indicate the signal range as specified by the EGL bit in TR.LIC1. Example; if EGL = 1 and in T1 mode, RL0 through RL3 will only indicate a signal range of >-2.5dB to -15dB even if the signal is < -15dB.

Register Name: **TR.INFO3**
 Register Description: **Information Register 3**
 Register Address: **12h**

Bit #	7	6	5	4	3	2	1	0
Name	—	—	—	—	—	CRCRC	FASRC	CASRC
Default	0	0	0	0	0	0	0	0

Bit 2: CRC Resync Criteria Met Event (CRCRC). Set when 915/1000 codewords are received in error.

Bit 1: FAS Resync Criteria Met Event (FASRC). Set when three consecutive FAS words are received in error. Note: During a CRC resync the FAS synchronizer is brought online to verify the FAS alignment. If during this process an FAS emulator exists, the FAS synchronizer may temporarily align to the emulator. The FASRC will go active indicating a search for a valid FAS has been activated.

Bit 0: CAS Resync Criteria Met Event (CASRC). Set when two consecutive CAS MF alignment words are received in error.

Register Name: **TR.IIR1**
 Register Description: **Interrupt Information Register 1**
 Register Address: **14h**

Bit #	7	6	5	4	3	2	1	0
Name	SR8	SR7	SR6	SR5	SR4	SR3	SR2	SR1
Default	0	0	0	0	0	0	0	0

Bits 0 – 7: Status Register 1 – 8 (SR1–SR8). When set to 1, these bits indicate that an enabled interrupt is active in the associated T1/E1/J1 status register.

Register Name: **TR.IIR2**
 Register Description: **Interrupt Information Register 2**
 Register Address: **15h**

Bit #	7	6	5	4	3	2	1	0
Name	—	—	—	—	—	—	—	SR9
Default	0	0	0	0	0	0	0	0

Bits 0: Status Register 9 (SR9). When set to 1, this bit indicates that an enabled interrupt is active in the associated T1/E1/J1 status register.

Register Name: **TR.SR1**
 Register Description: **Status Register 1**
 Register Address: **16h**

Bit #	7	6	5	4	3	2	1	0
Name	ILUT	TIMER	RSCOS	JALT	LRCL	TCLE	TOCD	LOLITC
Default	0	0	0	0	0	0	0	0

Bit 7: Input Level Under Threshold (ILUT). This bit is set whenever the input level at RTIP and RRING falls below the threshold set by the value in TR.CCR4.4 through TR.CCR4.7. The level must remain below the programmed threshold for approximately 50ms for this bit to be set. This is a double interrupt bit (Section [9.7](#)).

Bit 6: Timer Event (TIMER). Follows the error-counter update interval as determined by the ECUS bit in the error-counter configuration register (TR.ERCNT).

T1: set on increments of 1 second or 42ms based on RCLKO

E1: set on increments of 1 second or 62.5ms based on RCLKO

Bit 5: Receive Signaling Change-of-State Event (RSCOS). Set when any channel selected by the receive signaling change-of-state interrupt-enable registers (TR.RSCSE1 through TR.RSCSE4) changes signaling state.

Bit 4: Jitter Attenuator Limit Trip Event (JALT). Set when the jitter attenuator FIFO reaches to within 4 bits of its useful limit. This bit is cleared when read. Useful for debugging jitter attenuation operation.

Bit 3: Line Interface Receive Carrier-Loss Condition (LRCL). Set when the carrier signal is lost. This is a double interrupt bit (Section [9.7](#)).

Bit 2: Transmit Current-Limit Exceeded Condition (TCLE). Set when the 50mA (RMS) current limiter is activated, whether the current limiter is enabled or not. This is a double interrupt bit (Section [9.7](#)).

Bit 1: Transmit Open-Circuit Detect Condition (TOCD). Set when the device detects that the TTIP and TRING outputs are open-circuited. This is a double interrupt bit (Section [9.7](#)).

Bit 0: Loss of Line-Interface Transmit-Clock Condition (LOLITC). Set when TDCLKI has not transitioned for one channel time. This is a double interrupt bit (Section [9.7](#)).

Register Name: **TR.IMR1**
 Register Description: **Interrupt Mask Register 1**
 Register Address: **17h**

Bit #	7	6	5	4	3	2	1	0
Name	ILUT	TIMER	RSCOS	JALT	LRCL	TCLE	TOCD	LOLITC
Default	0	0	0	0	0	0	0	0

Bit 7: Input Level Under Threshold (ILUT)

0 = interrupt masked
 1 = interrupt enabled

Bit 6: Timer Event (TIMER)

0 = interrupt masked
 1 = interrupt enabled

Bit 5: Receive Signaling Change-of-State Event (RSCOS)

0 = interrupt masked
 1 = interrupt enabled

Bit 4: Jitter Attenuator Limit Trip Event (JALT)

0 = interrupt masked
 1 = interrupt enabled

Bit 3: Line Interface Receive Carrier-Loss Condition (LRCL)

0 = interrupt masked
 1 = interrupt enabled—generates interrupts on rising and falling edges

Bit 2: Transmit Current-Limit Exceeded Condition (TCLE)

0 = interrupt masked
 1 = interrupt enabled—generates interrupts on rising and falling edges

Bit 1: Transmit Open-Circuit Detect Condition (TOCD)

0 = interrupt masked
 1 = interrupt enabled—generates interrupts on rising and falling edges

Bit 0: Loss-of-Transmit Clock Condition (LOLITC)

0 = interrupt masked
 1 = interrupt enabled—generates interrupts on rising and falling edges

Register Name: **TR.SR2**
 Register Description: **Status Register 2**
 Register Address: **18h**

Bit #	7	6	5	4	3	2	1	0
Name	RYELC	RUA1C	FRCLC	RLOSC	RYEL	RUA1	FRCL	RLOS
Default	0	0	0	0	0	0	0	0

Bit 7: Receive Yellow Alarm Clear Event (RYELC) (T1 Only). Set when the receive Yellow Alarm condition is no longer detected.

Bit 6: Receive Unframed All-Ones Clear Event (RUA1C). Set when the unframed all 1s condition is no longer detected.

Bit 5: Framer Receive Carrier-Loss Clear Event (FRCLC). Set when the carrier loss condition at RPOSI and RNEGI is no longer detected.

Bit 4: Receive Loss-of-Sync Clear Event (RLOSC). Set when the framer achieves synchronization; remains set until read.

Bit 3: Receive Yellow Alarm Condition (RYEL) (T1 Only). Set when a Yellow Alarm is received at RPOSI and RNEGI.

Bit 2: Receive Unframed All-Ones (T1 Blue Alarm, E1 AIS) Condition (RUA1). Set when an unframed all 1s code is received at RPOSI and RNEGI.

Bit 1: Framer Receive Carrier-Loss Condition (FRCL). Set when 255 (or 2048 if TR.E1RCR2.0 = 1) E1 mode or 192 T1 mode consecutive 0s have been detected at RPOSI and RNEGI.

Bit 0: Receive Loss-of-Sync Condition (RLOS). Set when the transceiver is not synchronized to the received data stream.

Register Name: **TR.IMR2**
 Register Description: **Interrupt Mask Register 2**
 Register Address: **19h**

Bit #	7	6	5	4	3	2	1	0
Name	RYELC	RUA1C	FRCLC	RLOSC	RYEL	RUA1	FRCL	RLOS
Default	0	0	0	0	0	0	0	0

Bit 7: Receive Yellow Alarm Clear Event (RYELC)

0 = interrupt masked
 1 = interrupt enabled

Bit 6: Receive Unframed All-Ones Condition Clear Event (RUA1C)

0 = interrupt masked
 1 = interrupt enabled

Bit 5: Framer Receive Carrier Loss Condition Clear (FRCLC)

0 = interrupt masked
 1 = interrupt enabled

Bit 4: Receive Loss-of-Sync Clear Event (RLOSC)

0 = interrupt masked
 1 = interrupt enabled

Bit 3: Receive Yellow Alarm Condition (RYEL)

0 = interrupt masked
 1 = interrupt enabled—interrupts on rising edge only

Bit 2: Receive Unframed All-Ones (Blue Alarm) Condition (RUA1)

0 = interrupt masked
 1 = interrupt enabled—interrupts on rising edge only

Bit 1: Framer Receive Carrier Loss Condition (FRCL)

0 = interrupt masked
 1 = interrupt enabled—interrupts on rising edge only

Bit 0: Receive Loss-of-Sync Condition (RLOS)

0 = interrupt masked
 1 = interrupt enabled—interrupts on rising edge only

Register Name: **TR.SR3**
 Register Description: **Status Register 3**
 Register Address: **1Ah**

Bit #	7	6	5	4	3	2	1	0
Name	LSPARE	LDN	LUP	LOTCL	LORCL	V52LNK	RDMA	RRA
Default	0	0	0	0	0	0	0	0

Bit 7: Spare Code Detected Condition (LSPARE) (T1 Only). Set when the spare code as defined in the TR.RSCD1/2 registers is being received. See Section [10.19](#) for details. This is a double interrupt bit. See Section [9.7](#).

Bit 6: Loop-Down Code Detected Condition (LDN) (T1 Only). Set when the loop down code as defined in the TR.RDNC1/2 register is being received. See Section [10.19](#) for details. This is a double interrupt bit. See Section [9.7](#).

Bit 5: Loop-Up Code Detected Condition (LUP) (T1 Only). Set when the loop-up code as defined in the TR.RUPC1/2 register is being received. See Section [10.19](#) for details. This is a double interrupt bit. See Section [9.7](#).

Bit 4: Loss-of-Transmit Clock Condition (LOTCL). Set when the TCLKT pin has not transitioned for one channel time. Forces the LOTCL pin high if enabled by TR.CCR1.0. This is a double interrupt bit. See Section [9.7](#).

Bit 3: Loss-of-Receive Clock Condition (LORCL). Set when the RDCLKI pin has not transitioned for one channel time. This is a double interrupt bit. See Section [9.7](#).

Bit 2: V5.2 Link Detected Condition (V52LNK) (E1 Only). Set on detection of a V5.2 link identification signal (G.965). This is a double interrupt bit. See Section [9.7](#).

Bit 1: Receive Distant MF Alarm Condition (RDMA) (E1 Only). Set when bit 6 of time slot 16 in frame 0 has been set for two consecutive multiframes. This alarm is not disabled in the CCS signaling mode. This is a double interrupt bit. See Section [9.7](#).

Bit 0: Receive Remote Alarm Condition (RRA) (E1 Only). Set when a remote alarm is received at RPOSI and RNEGI. This is a double interrupt bit. See Section [9.7](#).

Register Name: **TR.IMR3**
 Register Description: **Interrupt Mask Register 3**
 Register Address: **1Bh**

Bit #	7	6	5	4	3	2	1	0
Name	LSPARE	LDN	LUP	LOTCT	LORC	V52LNK	RDMA	RRA
Default	0	0	0	0	0	0	0	0

Bit 7: Spare Code Detected Condition (LSPARE)

0 = interrupt masked
 1 = interrupt enabled—interrupts on rising and falling edges

Bit 6: Loop-Down Code-Detected Condition (LDN)

0 = interrupt masked
 1 = interrupt enabled—interrupts on rising and falling edges

Bit 5: Loop-Up Code-Detected Condition (LUP)

0 = interrupt masked
 1 = interrupt enabled—interrupts on rising and falling edges

Bit 4: Loss-of-Transmit Clock Condition (LOTCT)

0 = interrupt masked
 1 = interrupt enabled—interrupts on rising and falling edges

Bit 3: Loss-of-Receive Clock Condition (LORC)

0 = interrupt masked
 1 = interrupt enabled—interrupts on rising and falling edges

Bit 2: V5.2 Link Detected Condition (V52LNK)

0 = interrupt masked
 1 = interrupt enabled—interrupts on rising and falling edges

Bit 1: Receive Distant MF Alarm Condition (RDMA)

0 = interrupt masked
 1 = interrupt enabled—interrupts on rising and falling edges

Bit 0: Receive Remote Alarm Condition (RRA)

0 = interrupt masked
 1 = interrupt enabled—interrupts on rising and falling edges

Register Name: **TR.SR4**
 Register Description: **Status Register 4**
 Register Address: **1Ch**

Bit #	7	6	5	4	3	2	1	0
Name	RAIS-CI	RSAO	RSAZ	TMF	TAF	RMF	RCMF	RAF
Default	0	0	0	0	0	0	0	0

Bit 7: Receive AIS-CI Event (RAIS-CI) (T1 Only). Set when the receiver detects the AIS-CI pattern as defined in ANSI T1.403.

Bit 6: Receive Signaling All-Ones Event (RSAO) (E1 Only). Set when the contents of time slot 16 contains fewer than three 0s over 16 consecutive frames. This alarm is not disabled in the CCS signaling mode.

Bit 5: Receive Signaling All-Zeros Event (RSAZ) (E1 Only). Set when over a full MF, time slot 16 contains all 0s.

Bit 4: Transmit Multiframe Event (TMF)

E1 Mode: Set every 2ms (regardless if CRC4 is enabled) on transmit multiframe boundaries. Used to alert the host that signaling data needs to be updated.

T1 Mode: Set every 1.5ms on D4 MF boundaries or every 3ms on ESF MF boundaries.

Bit 3: Transmit Align Frame Event (TAF) (E1 Only). Set every 250 μ s at the beginning of align frames. Used to alert the host that the TR.TAF and TR.TNAF registers need to be updated.

Bit 2: Receive Multiframe Event (RMF)

E1 Mode: Set every 2ms (regardless if CAS signaling is enabled or not) on receive multiframe boundaries. Used to alert the host that signaling data is available.

T1 Mode: Set every 1.5ms on D4 MF boundaries or every 3ms on ESF MF boundaries.

Bit 1: Receive CRC4 Multiframe Event (RCMF) (E1 Only). Set on CRC4 multiframe boundaries; continues to set every 2ms on an arbitrary boundary if CRC4 is disabled.

Bit 0: Receive Align Frame Event (RAF) (E1 Only). Set every 250 μ s at the beginning of align frames. Used to alert the host that Si and Sa bits are available in the TR.RAF and TR.RNAF registers.

Register Name: **TR.IMR4**
 Register Description: **Interrupt Mask Register 4**
 Register Address: **1Dh**

Bit #	7	6	5	4	3	2	1	0
Name	RAIS-CI	RSAO	RSAZ	TMF	TAF	RMF	RCMF	RAF
Default	0	0	0	0	0	0	0	0

Bit 7: Receive AIS-CI Event (RAIS-CI)

0 = interrupt masked
 1 = interrupt enabled

Bit 6: Receive Signaling All-Ones Event (RSAO)

0 = interrupt masked
 1 = interrupt enabled

Bit 5: Receive Signaling All-Zeros Event (RSAZ)

0 = interrupt masked
 1 = interrupt enabled

Bit 4: Transmit Multiframe Event (TMF)

0 = interrupt masked
 1 = interrupt enabled

Bit 3: Transmit Align Frame Event (TAF)

0 = interrupt masked
 1 = interrupt enabled

Bit 2: Receive Multiframe Event (RMF)

0 = interrupt masked
 1 = interrupt enabled

Bit 1: Receive CRC4 Multiframe Event (RCMF)

0 = interrupt masked
 1 = interrupt enabled

Bit 0: Receive Align Frame Event (RAF)

0 = interrupt masked
 1 = interrupt enabled

Register Name: **TR.SR5**
 Register Description: **Status Register 5**
 Register Address: **1Eh**

Bit #	7	6	5	4	3	2	1	0
Name	—	—	TESF	TESEM	TSLIP	RESF	RESEM	RSLIP
Default	0	0	0	0	0	0	0	0

Bit 5: Transmit Elastic Store Full Event (TESF). Set when the transmit elastic store buffer fills and a frame is deleted.

Bit 4: Transmit Elastic Store Empty Event (TESEM). Set when the transmit elastic store buffer empties and a frame is repeated.

Bit 3: Transmit Elastic Store Slip-Occurrence Event (TSLIP). Set when the transmit elastic store has either repeated or deleted a frame.

Bit 2: Receive Elastic Store Full Event (RESF). Set when the receive elastic store buffer fills and a frame is deleted.

Bit 1: Receive Elastic Store Empty Event (RESEM). Set when the receive elastic store buffer empties and a frame is repeated.

Bit 0: Receive Elastic Store Slip-Occurrence Event (RSLIP). Set when the receive elastic store has either repeated or deleted a frame.

Register Name: **TR.IMR5**
 Register Description: **Interrupt Mask Register 5**
 Register Address: **1Fh**

Bit #	7	6	5	4	3	2	1	0
Name	—	—	TESF	TESEM	TSLIP	RESF	RESEM	RSLIP
Default	0	0	0	0	0	0	0	0

Bit 5: Transmit Elastic Store Full Event (TESF)

0 = interrupt masked
 1 = interrupt enabled

Bit 4: Transmit Elastic Store Empty Event (TESEM)

0 = interrupt masked
 1 = interrupt enabled

Bit 3: Transmit Elastic Store Slip-Occurrence Event (TSLIP)

0 = interrupt masked
 1 = interrupt enabled

Bit 2: Receive Elastic Store Full Event (RESF)

0 = interrupt masked
 1 = interrupt enabled

Bit 1: Receive Elastic Store Empty Event (RESEM)

0 = interrupt masked
 1 = interrupt enabled

Bit 0: Receive Elastic Store Slip-Occurrence Event (RSLIP)

0 = interrupt masked
 1 = interrupt enabled

Register Name: **TR.SR6, TR.SR7**
 Register Description: **HDLC #1 Status Register 6**
HDLC #2 Status Register 7
 Register Address: **20h, 22h**

Bit #	7	6	5	4	3	2	1	0
Name	—	TMEND	RPE	RPS	RHWM	RNE	TLWM	TNF
Default	0	0	0	0	0	0	0	0

Bit 6: Transmit Message-End Event (TMEND). Set when the transmit HDLC controller has finished sending a message. This is a latched bit and is cleared when read.

Bit 5: Receive Packet-End Event (RPE). Set when the HDLC controller detects either the finish of a valid message (i.e., CRC check complete) or when the controller has experienced a message fault such as a CRC checking error, or an overrun condition, or an abort has been seen. This is a latched bit and is cleared when read.

Bit 4: Receive Packet-Start Event (RPS). Set when the HDLC controller detects an opening byte. This is a latched bit and is cleared when read.

Bit 3: Receive FIFO Above High-Watermark Condition (RHWM). Set when the receive 128-byte FIFO fills beyond the high watermark as defined by the receive high-watermark register (TR.RHWMR).

Bit 2: Receive FIFO Not Empty Condition (RNE). Set when the receive 128-byte FIFO has at least 1 byte available for a read.

Bit 1: Transmit FIFO Below Low-Watermark Condition (TLWM). Set when the transmit 128-byte FIFO empties beyond the low watermark as defined by the transmit low-watermark register (TR.TLWMR).

Bit 0: Transmit FIFO Not Full Condition (TNF). Set when the transmit 128-byte FIFO has at least 1 byte available.

Register Name: **TR.IMR6, TR.IMR7**
 Register Description: **HDLC # 1 Interrupt Mask Register 6**
HDLC # 2 Interrupt Mask Register 7
 Register Address: **21h, 23h**

Bit #	7	6	5	4	3	2	1	0
Name	—	TMEND	RPE	RPS	RHWM	RNE	TLWM	TNF
Default	0	0	0	0	0	0	0	0

Bit 6: Transmit Message-End Event (TMEND)

0 = interrupt masked
 1 = interrupt enabled

Bit 5: Receive Packet-End Event (RPE)

0 = interrupt masked
 1 = interrupt enabled

Bit 4: Receive Packet-Start Event (RPS)

0 = interrupt masked
 1 = interrupt enabled

Bit 3: Receive FIFO Above High-Watermark Condition (RHWM)

0 = interrupt masked
 1 = interrupt enabled—interrupts on rising edge only

Bit 2: Receive FIFO Not Empty Condition (RNE)

0 = interrupt masked
 1 = interrupt enabled—interrupts on rising edge only

Bit 1: Transmit FIFO Below Low-Watermark Condition (TLWM)

0 = interrupt masked
 1 = interrupt enabled—interrupts on rising edge only

Bit 0: Transmit FIFO Not Full Condition (TNF)

0 = interrupt masked
 1 = interrupt enabled—interrupts on rising edge only

Register Name: **TR.INFO5, TR.INFO6**
 Register Description: **HDLC #1 Information Register**
HDLC #2 Information Register
 Register Address: **2Eh, 2Fh**

Bit #	7	6	5	4	3	2	1	0
Name	—	—	EMPTY	TFULL	EMPTY	PS2	PS1	PS0
Default	0	0	0	0	0	0	0	0

Bit 5: Transmit FIFO Empty (EMPTY). A real-time bit that is set high when the FIFO is empty.

Bit 4: Transmit FIFO Full (TFULL). A real-time bit that is set high when the FIFO is full.

Bit 3: Receive FIFO Empty (EMPTY). A real-time bit that is set high when the receive FIFO is empty.

Bits 0 – 2: Receive Packet Status (PS0 to PS2). These are real-time bits indicating the status as of the last read of the receive FIFO.

PS2	PS1	PS0	Packet Status
0	0	0	In Progress
0	0	1	Packet OK: Packet ended with correct CRC codeword
0	1	0	CRC Error: A closing flag was detected, preceded by a corrupt CRC codeword
0	1	1	Abort: Packet ended because an abort signal was detected (seven or more 1s in a row).
1	0	0	Overrun: HDLC controller terminated reception of packet because receive FIFO is full.

Register Name: **TR.INFO4**
 Register Description: **HDLC Event Information Register #4**
 Register Address: **2Dh**

Bit #	7	6	5	4	3	2	1	0
Name	—	—	—	—	H2UDR	H2OBT	H1UDR	H1OBT
Default	0	0	0	0	0	0	0	0

Bit 3: HDLC #2 Transmit FIFO Underrun Event (H2UDR). Set when the transmit FIFO empties out without having seen the TMEND bit set. An abort is automatically sent. This bit is latched and is cleared when read.

Bit 2: HDLC #2 Opening Byte Event (H2OBT). Set when the next byte available in the receive FIFO is the first byte of a message.

Bit 1: HDLC #1 Transmit FIFO Underrun Event (H1UDR). Set when the transmit FIFO empties out without having seen the TMEND bit set. An abort is automatically sent. This bit is latched and is cleared when read.

Bit 0: HDLC #1 Opening Byte Event (H1OBT). Set when the next byte available in the receive FIFO is the first byte of a message.

Register Name: **TR.SR8**
 Register Description: **Status Register 8**
 Register Address: **24h**

Bit #	7	6	5	4	3	2	1	0
Name	—	—	BOCC	RFDLAD	RFDLF	TFDLE	RMTCH	RBOC
Default	0	0	0	0	0	0	0	0

Bit 5: BOC Clear Event (BOCC). Set when 30 FDL bits occur without an abort sequence.

Bit 4: RFDL Abort Detect Event (RFDLAD). Set when eight consecutive 1s are received on the FDL.

Bit 3: RFDL Register Full Event (RFDLF). Set when the receive FDL buffer (TR.RFDL) fills to capacity.

Bit 2: TFDL Register Empty Event (TFDLE). Set when the transmit FDL buffer (TR.TFDL) empties.

Bit 1: Receive FDL Match Event (RMTCH). Set whenever the contents of the TR.RFDL register matches TR.RFDLM1 or TR.RFDLM2.

Bit 0: Receive BOC Detector Change-of-State Event (RBOC). Set whenever the BOC detector sees a change of state to a valid BOC. The setting of this bit prompts the user to read the TR.RFDL register.

Register Name: **TR.IMR8**
 Register Description: **Interrupt Mask Register 8**
 Register Address: **25h**

Bit #	7	6	5	4	3	2	1	0
Name	—	—	BOCC	RFDLAD	RFDLF	TFDLE	RMTCH	RBOC
Default	0	0	0	0	0	0	0	0

Bit 5: BOC Clear Event (BOCC)

0 = interrupt masked
 1 = interrupt enabled

Bit 4: RFDL Abort Detect Event (RFDLAD)

0 = interrupt masked
 1 = interrupt enabled

Bit 3: RFDL Register Full Event (RFDLF)

0 = interrupt masked
 1 = interrupt enabled

Bit 2: TFDL Register Empty Event (TFDLE)

0 = interrupt masked
 1 = interrupt enabled

Bit 1: Receive FDL Match Event (RMTCH)

0 = interrupt masked
 1 = interrupt enabled

Bit 0: Receive BOC Detector Change-of-State Event (RBOC)

0 = interrupt masked
 1 = interrupt enabled

Register Name: **TR.SR9**
 Register Description: **Status Register 9**
 Register Address: **26h**

Bit #	7	6	5	4	3	2	1	0
Name	—	BBED	BBCO	BECO	BRA1	BRA0	BRLOS	BSYNC
Default	0	0	0	0	0	0	0	0

Bit 6: BERT Bit-Error Detected (BED) Event (BBED). A latched bit that is set when a bit error is detected. The receive BERT must be in synchronization for it to detect bit errors. Cleared when read.

Bit 5: BERT Bit-Counter Overflow Event (BBCO). A latched bit that is set when the 32-bit BERT bit counter (BBC) overflows. Cleared when read and is not set again until another overflow occurs.

Bit 4: BERT Error-Counter Overflow (BECO) Event (BECO). A latched bit that is set when the 24-bit BERT error counter (BEC) overflows. Cleared when read and is not set again until another overflow occurs.

Bit 3: BERT Receive All-Ones Condition (BRA1). A latched bit that is set when 32 consecutive 1s are received. Allowed to be cleared once a 0 is received. This is a double interrupt bit (Section [9.7](#)).

Bit 2: BERT Receive All-Zeros Condition (BRA0). A latched bit that is set when 32 consecutive 0s are received. Allowed to be cleared once a 1 is received. This is a double interrupt bit (Section [9.7](#)).

Bit 1: BERT Receive Loss-of-Synchronization Condition (BRLOS). A latched bit that is set whenever the receive BERT begins searching for a pattern. Once synchronization is achieved, this bit remains set until read. This is a double interrupt bit (Section [9.7](#)).

Bit 0: BERT in Synchronization Condition (BSYNC). Set when the incoming pattern matches for 32 consecutive bit positions. Refer to BSYNC in the TR.INFO2 register for a real-time version of this bit. This is a double interrupt bit (Section [9.7](#)).

Register Name: **TR.IMR9**
 Register Description: **Interrupt Mask Register 9**
 Register Address: **27h**

Bit #	7	6	5	4	3	2	1	0
Name	—	BBED	BBCO	BECO	BRA1	BRA0	BRLOS	BSYNC
Default	0	0	0	0	0	0	0	0

Bit 6: Bit-Error Detected Event (BBED)

0 = interrupt masked
 1 = interrupt enabled

Bit 5: BERT Bit-Counter Overflow Event (BBCO)

0 = interrupt masked
 1 = interrupt enabled

Bit 4: BERT Error-Counter Overflow Event (BECO)

0 = interrupt masked
 1 = interrupt enabled

Bit 3: Receive All-Ones Condition (BRA1)

0 = interrupt masked
 1 = interrupt enabled—interrupts on rising and falling edges

Bit 2: Receive All-Zeros Condition (BRA0)

0 = interrupt masked
 1 = interrupt enabled—interrupts on rising and falling edges

Bit 1: Receive Loss-of-Synchronization Condition (BRLOS)

0 = interrupt masked
 1 = interrupt enabled—interrupts on rising and falling edges

Bit 0: BERT in Synchronization Condition (BSYNC)

0 = interrupt masked
 1 = interrupt enabled—interrupts on rising and falling edges

Register Name: **TR.PCPR**
 Register Description: **Per-Channel Pointer Register**
 Register Address: **28h**

Bit #	7	6	5	4	3	2	1	0
Name	RSAOICS	RSRCS	RFCS	BRCS	THSCS	PEICS	TFCS	BTCS
Default	0	0	0	0	0	0	0	0

Bit 7: Receive Signaling All-Ones Insertion Channel Select (RSAOICS)

Bit 6: Receive Signaling Reinsertion Channel Select (RSRCS)

Bit 5: Receive Fractional Channel Select (RFCS)

Bit 4: Bert Receive Channel Select (BRCS)

Bit 3: Transmit Hardware Signaling Channel Select (THSCS)

Bit 2: Payload Error Insert Channel Select (PEICS)

Bit 1: Transmit Fractional Channel Select (TFCS)

Bit 0: Bert Transmit Channel Select (BTCS)

See Section [10.2](#) for a general overview of per-channel operation. See Section [10.10](#) for more information on per-channel idle code generation. See Section [10.6](#) for more information on per-channel loopback operation.

Register Name: **TR.PCDR1**
 Register Description: **Per-Channel Data Register 1**
 Register Address: **29h**

Bit #	7	6	5	4	3	2	1	0
Name	—	—	—	—	—	—	—	—
Default	CH8	CH7	CH6	CH5	CH4	CH3	CH2	CH1

Register Name: **TR.PCDR2**
 Register Description: **Per-Channel Data Register 2**
 Register Address: **2Ah**

Bit #	7	6	5	4	3	2	1	0
Name	—	—	—	—	—	—	—	—
Default	CH16	CH15	CH14	CH13	CH12	CH11	CH10	CH9

Register Name: **TR.PCDR3**
 Register Description: **Per-Channel Data Register 3**
 Register Address: **2Bh**

Bit #	7	6	5	4	3	2	1	0
Name	—	—	—	—	—	—	—	—
Default	CH24	CH23	CH22	CH21	CH20	CH19	CH18	CH17

Register Name: **TR.PCDR4**
 Register Description: **Per-Channel Data Register 4**
 Register Address: **2Ch**

Bit #	7	6	5	4	3	2	1	0
Name	—	—	—	—	—	—	—	—
Default	CH32	CH31	CH30	CH29	CH28	CH27	CH26	CH25

See Section [10.2](#) for a general overview of per-channel operation. See Section [10.10](#) for more information on per-channel idle code generation. See Section [10.6](#) for more information on per-channel loopback operation.

Register Name: **TR.INFO7**
 Register Description: **Information Register 7 (Real-Time, Non-Latched Register)**
 Register Address: **30h**

Bit #	7	6	5	4	3	2	1	0
Name	CSC5	CSC4	CSC3	CSC2	CSC0	FASSA	CASSA	CRC4SA
Default	0	0	0	0	0	0	0	0

Bits 3 – 7: CRC4 Sync Counter Bits (CSC0, CSC2 to CSC4). The CRC4 sync counter increments each time the 8ms CRC4 multiframe search times out. The counter is cleared when the framer has successfully obtained synchronization at the CRC4 level. The counter can also be cleared by disabling the CRC4 mode (TR.E1RCR1.3 = 0). This counter is useful for determining the amount of time the framer has been searching for synchronization at the CRC4 level. ITU G.706 suggests that if synchronization at the CRC4 level cannot be obtained within 400ms, then the search should be abandoned and proper action taken. The CRC4 sync counter rolls over. CSC0 is the LSB of the 6-bit counter. (Note: The bit next to LSB is not accessible. CSC1 is omitted to allow resolution to >400ms using 5 bits.) These are read-only, non-latched, real-time bits. It is not necessary to precede the read of these bits with a write.

Bit 2: FAS Sync Active (FASSA). Set while the synchronizer is searching for alignment at the FAS level. This is a read-only, non-latched, real-time bit. It is not necessary to precede the read of this bit with a write.

Bit 1: CAS MF Sync Active (CASSA). Set while the synchronizer is searching for the CAS MF alignment word. This is a read-only, non-latched, real-time bit. It is not necessary to precede the read of this bit with a write.

Bit 0: CRC4 MF Sync Active (CRC4SA). Set while the synchronizer is searching for the CRC4 MF alignment word. This is a read-only, non-latched, real-time bit. It is not necessary to precede the read of this bit with a write.

Register Name: **TR.H1RC, TR.H2RC**
 Register Description: **HDLC #1 Receive Control
 HDLC #2 Receive Control**
 Register Address: **31h, 32h**

Bit #	7	6	5	4	3	2	1	0
Name	RHR	RHMS	—	—	—	—	—	RSFD
Default	0	0	0	0	0	0	0	0

Bit 7: Receive HDLC Reset (RHR). Resets the receive HDLC controller and flushes the receive FIFO. Must be cleared and set again for a subsequent reset.

0 = normal operation

1 = reset receive HDLC controller and flush the receive FIFO

Bit 6: Receive HDLC Mapping Select (RHMS)

0 = receive HDLC assigned to channels

1 = receive HDLC assigned to FDL (T1 mode), Sa bits (E1 mode)

Bits 1 – 5: Unused, must be set to 0 or proper operation

Bit 0: Receive SS7 Fill-In Signal Unit Delete (RSFD)

0 = normal operation; all FISUs are stored in the receive FIFO and reported to the host.

1 = When a consecutive FISU having the same BSN the previous FISU is detected, it is deleted without host intervention.

Register Name: **TR.E1RCR1**
 Register Description: **E1 Receive Control Register 1**
 Register Address: **33h**

Bit #	7	6	5	4	3	2	1	0
Name	RSERC	RSIGM	RHDB3	RG802	RCRC4	FRC	SYNCE	RESYNC
Default	0	0	0	0	0	0	0	0

Bit 7: RSERO Control (RSERC)

0 = allow RSERO to output data as received under all conditions
 1 = force RSERO to 1 under loss-of-frame alignment conditions

Bit 6: Receive Signaling Mode Select (RSIGM)

0 = CAS signaling mode
 1 = CCS signaling mode

Bit 5: Receive HDB3 Enable (RHDB3)

0 = HDB3 disabled
 1 = HDB3 enabled

Bit 4: Receive G.802 Enable (RG802). See Section [10.10](#) for details.

0 = do not force RCHBLK high during bit 1 of time slot 26
 1 = force RCHBLK high during bit 1 of time slot 26

Bit 3: Receive CRC4 Enable (RCRC4)

0 = CRC4 disabled
 1 = CRC4 enabled

Bit 2: Frame Resync Criteria (FRC)

0 = resync if FAS received in error three consecutive times
 1 = resync if FAS or bit 2 of non-FAS is received in error three consecutive times

Bit 1: Sync Enable (SYNCE)

0 = auto resync enabled
 1 = auto resync disabled

Bit 0: Resync (RESYNC). When toggled from low to high, a resync is initiated. Must be cleared and set again for a subsequent resync.

Register Name: **TR.E1RCR2**
 Register Description: **E1 Receive Control Register 2**
 Register Address: **34h**

Bit #	7	6	5	4	3	2	1	0
Name	—	—	—	—	—	—	—	RCLA
Default	0	0	0	0	0	0	0	0

Bit 0: Receive Carrier-Loss (RCL) Alternate Criteria (RCLA). Defines the criteria for a receive carrier-loss condition for both the framer and LIU.

0 = RCL declared upon 255 consecutive 0s (125 μ s)
 1 = RCL declared upon 2048 consecutive 0s (1ms)

Register Name: **TR.E1TCR1**
 Register Description: **E1 Transmit Control Register 1**
 Register Address: **35h**

Bit #	7	6	5	4	3	2	1	0
Name	TFPT	T16S	TUA1	TSiS	TSA1	THDB3	TG802	TCRC4
Default	0	0	0	0	0	0	0	0

Bit 7: Transmit Time Slot 0 Pass-Through (TFPT)

0 = FAS bits/Sa bits/remote alarm sourced internally from the TR.TAF and TR.TNAF registers
 1 = FAS bits/Sa bits/remote alarm sourced from TSERI

Bit 6: Transmit Time Slot 16 Data Select (T16S)

0 = time slot 16 determined by the TR.SSiEx registers and the THSCS function in the TR.PCPR register
 1 = source time slot 16 from TR.TS1 to TR.TS16 registers

Bit 5: Transmit Unframed All Ones (TUA1)

0 = transmit data normally
 1 = transmit an unframed all-ones code at TPOSO and TNEGO

Bit 4: Transmit International Bit Select (TSiS)

0 = sample Si bits at TSERI pin
 1 = source Si bits from TR.TAF and TR.TNAF registers (in this mode, TR.E1TCR1.7 must be set to 0)

Bit 3: Transmit Signaling All Ones (TSA1)

0 = normal operation
 1 = force time slot 16 in every frame to all ones

Bit 2: Transmit HDB3 Enable (THDB3)

0 = HDB3 disabled
 1 = HDB3 enabled

Bit 1: Transmit G.802 Enable (TG802). See Section [10.10](#) for details.

0 = do not force TCHBLK high during bit 1 of time slot 26
 1 = force TCHBLK high during bit 1 of time slot 26

Bit 0: Transmit CRC4 Enable (TCRC4)

0 = CRC4 disabled
 1 = CRC4 enabled

Register Name: **TR.E1TCR2**
 Register Description: **E1 Transmit Control Register 2**
 Register Address: **36h**

Bit #	7	6	5	4	3	2	1	0
Name	-	-	-	-	-	AEBE	AAIS	ARA
Default	0	0	0	0	0	0	0	0

Bit 2: Automatic E-Bit Enable (AEBE)

0 = E-bits not automatically set in the transmit direction
 1 = E-bits automatically set in the transmit direction

Bit 1: Automatic AIS Generation (AAIS)

0 = disabled
 1 = enabled

Bit 0: Automatic Remote Alarm Generation (ARA)

0 = disabled
 1 = enabled

Register Name: **TR.BOCC**
 Register Description: **BOC Control Register**
 Register Address: **37h**

Bit #	7	6	5	4	3	2	1	0
Name	—	—	—	RBOCE	RBR	RBF1	RBF0	SBOC
Default	0	0	0	0	0	0	0	0

Bit 4: Receive BOC Enable (RBOCE). Enables the receive BOC function. The TR.RFDL register reports the received BOC code and two information bits when this bit is set.

0 = receive BOC function disabled
 1 = receive BOC function enabled; the TR.RFDL register reports BOC messages and information

Bit 3: Receive BOC Reset (RBR). A 0-to-1 transition resets the BOC circuitry. Must be cleared and set again for a subsequent reset.

Bits 1 – 2: Receive BOC Filter Bits (RBF0, RBF1). The BOC filter sets the number of consecutive patterns that must be received without error prior to an indication of a valid message.

RBF1	RBF0	Consecutive BOC Codes for Valid Sequence Identification
0	0	None
0	1	3
1	0	5
1	1	7

Bit 0: Send BOC (SBOC). Set = 1 to transmit the BOC code placed in bits 0 to 5 of the TR.TFDL register.

Register Name: **TR.RSINFO1, TR.RSINFO2, TR.RSINFO3, TR.RSINFO4**
 Register Description: **Receive Signaling Change-of-State Information**
 Register Address: **38h, 39h, 3Ah, 3Bh**

(MSB)							(LSB)	
CH8	CH7	CH6	CH5	CH4	CH3	CH2	CH1	RSINFO1
CH16	CH15	CH14	CH13	CH12	CH11	CH10	CH9	RSINFO2
CH24	CH23	CH22	CH21	CH20	CH19	CH18	CH17	RSINFO3
		CH30	CH29	CH28	CH27	CH26	CH25	RSINFO4

When a channel's signaling data changes state, the respective bit in registers TR.RSINFO1–4 is set. An interrupt is generated if the channel was also enabled as an interrupt source by setting the appropriate bit in TR.RSCSE1–4. The bit remains set until read.

Register Name: **TR.RSCSE1, TR.RSCSE2, TR.RSCSE3, TR.RSCSE4**
 Register Description: **Receive Signaling Change-of-State Interrupt Enable**
 Register Address: **3Ch, 3Dh, 3Eh, 3Fh**

(MSB)							(LSB)	
CH8	CH7	CH6	CH5	CH4	CH3	CH2	CH1	RSCSE1
CH16	CH15	CH14	CH13	CH12	CH11	CH10	CH9	RSCSE2
CH24	CH23	CH22	CH21	CH20	CH19	CH18	CH17	RSCSE3
		CH30	CH29	CH28	CH27	CH26	CH25	RSCSE4

Setting any of the CH1–CH30 bits in the TR.RSCSE1– TR.RSCSE4 registers causes an interrupt when that channel's signaling data changes state.

Register Name: **TR.SIGCR**
 Register Description: **Signaling Control Register**
 Register Address: **40h**

Bit #	7	6	5	4	3	2	1	0
Name	GRSRE	—	—	RFE	RFF	RCCS	TCCS	FRSAO
Default	0	0	0	0	0	0	0	0

Bit 7: Global Receive Signaling Reinsertion Enable (GRSRE). This bit allows the user to reinsert all signaling channels without programming all channels through the per-channel function.

- 0 = do not reinsert all signaling
- 1 = reinsert all signaling

Bit 4: Receive Freeze Enable (RFE). See Section [10.9.2.3](#) for details.

- 0 = no freezing of receive signaling data occurs
- 1 = allow freezing of receive signaling data at RSIG (and RSERO if receive signaling reinsertion is enabled)

Bit 3: Receive Force Freeze (RFF). Freezes receive-side signaling at RSIG (and RSERO if receive signaling reinsertion is enabled); overrides receive freeze enable (RFE). See Section [10.9.2.3](#) for details.

- 0 = do not force a freeze event
- 1 = force a freeze event

Bit 2: Receive Time Slot Control for CAS Signaling (RCCS). Controls the order that signaling is placed into the receive signaling registers. This bit should be set = 0 in T1 mode.

- 0 = signaling data is CAS format
- 1 = signaling data is CCS format

Bit 1: Transmit Time Slot Control for CAS Signaling (TCCS). Controls the order that signaling is transmitted from the transmit signaling registers. This bit should be set = 0 in T1 mode.

- 0 = signaling data is CAS format
- 1 = signaling data is CCS format

Bit 0: Force Receive Signaling All Ones (FRSAO). In T1 mode, this bit forces all signaling data at the RSIG and RSERO pin to all ones. This bit has no effect in E1 mode.

- 0 = normal signaling data at RSIG and RSERO
- 1 = force signaling data at RSIG and RSERO to all ones

Register Name: **TR.ERCNT**
 Register Description: **Error-Counter Configuration Register**
 Register Address: **41h**

Bit #	7	6	5	4	3	2	1	0
Name	—	MECU	ECUS	EAMS	VCRFS	FSBE	MOSCRF	LCVCRF
Default	0	0	0	0	0	0	0	0

Bit 6: Manual Error-Counter Update (MECU). When enabled by TR.ERCNT.4, the changing of this bit from a 0 to a 1 allows the next clock cycle to load the error-counter registers with the latest counts and reset the counters. The user must wait a minimum of 1.5 RCLKO clock periods before reading the error count registers to allow for proper update.

Bit 5: Error-Counter Update Select (ECUS)

T1 Mode:

- 0 = update error counters once a second
- 1 = update error counters every 42ms (333 frames)

E1 Mode:

- 0 = update error counters once a second
- 1 = update error counters every 62.5ms (500 frames)

Bit 4: Error-Accumulation Mode Select (EAMS)

- 0 = TR.ERCNT.5 determines accumulation time
- 1 = TR.ERCNT.6 determines accumulation time

Bit 3: E1 Line-Code Violation Count Register Function Select (VCRFS)

- 0 = count bipolar violations (BPVs)
- 1 = count code violations (CVs)

Bit 2: PCVCR Fs-Bit Error-Report Enable (FSBE)

- 0 = do not report bit errors in Fs-bit position; only Ft-bit position
- 1 = report bit errors in Fs-bit position as well as Ft-bit position

Bit 1: Multiframe Out-of-Sync Count Register Function Select (MOSCRF)

- 0 = count errors in the framing bit position
- 1 = count the number of multiframe out-of-sync

Bit 0: T1 Line-Code Violation Count Register Function Select (LCVCRF)

- 0 = do not count excessive 0s
- 1 = count excessive 0s

Register Name: **TR.LCVCR1**
 Register Description: **Line-Code Violation Count Register 1**
 Register Address: **42h**

Bit #	7	6	5	4	3	2	1	0
Name	LCVC15	LCVC14	LCVC13	LCVC12	LCVC11	LCVC10	LCVC9	LCVC8
Default	0	0	0	0	0	0	0	0

Bits 0 – 7: Line-Code Violation Counter Bits 8 to 15 (LCVC8 to LCVC15). LCVC15 is the MSB of the 16-bit code violation count.

Register Name: **TR.LCVCR2**
 Register Description: **Line-Code Violation Count Register 2**
 Register Address: **43h**

Bit #	7	6	5	4	3	2	1	0
Name	LCVC7	LCVC6	LCVC5	LCVC4	LCVC3	LCVC2	LCVC1	LCVC0
Default	0	0	0	0	0	0	0	0

Bits 0 – 7: Line-Code Violation Counter Bits 0 to 7 (LCVC0 to LCVC7). LCVC0 is the LSB of the 16-bit code violation count.

Register Name: **TR.PCVCR1**
 Register Description: **Path Code Violation Count Register 1**
 Register Address: **44h**

Bit #	7	6	5	4	3	2	1	0
Name	PCVC15	PCVC14	PCVC13	PCVC12	PCVC11	PCVC10	PCVC9	PCVC8
Default	0	0	0	0	0	0	0	0

Bits 0 – 7: Path Code Violation Counter Bits 8 to 15 (PCVC8 to PCVC15). PCVC15 is the MSB of the 16-bit path code violation count.

Register Name: **TR.PCVCR2**
 Register Description: **Path Code Violation Count Register 2**
 Register Address: **45h**

Bit #	7	6	5	4	3	2	1	0
Name	PCVC7	PCVC6	PCVC5	PCVC4	PCVC3	PCVC2	PCVC1	PCVC0
Default	0	0	0	0	0	0	0	0

Bits 0 – 7: Path Code Violation Counter Bits 0 to 7 (PCVC0 to PCVC7). PCVC0 is the LSB of the 16-bit path code violation count.

Register Name: **TR.FOSCR1**
 Register Description: **Frames Out-of-Sync Count Register 1**
 Register Address: **46h**

Bit #	7	6	5	4	3	2	1	0
Name	FOS15	FOS14	FOS13	FOS12	FOS11	FOS10	FOS9	FOS8
Default	0	0	0	0	0	0	0	0

Bits 0 – 7: Frames Out-of-Sync Counter Bits 8 to 15 (FOS8 to FOS15). FOS15 is the MSB of the 16-bit frames out-of-sync count.

Register Name: **TR.FOSCR2**
 Register Description: **Frames Out-of-Sync Count Register 2**
 Register Address: **47h**

Bit #	7	6	5	4	3	2	1	0
Name	FOS7	FOS6	FOS5	FOS4	FOS3	FOS2	FOS1	FOS0
Default	0	0	0	0	0	0	0	0

Bits 0 – 7: Frames Out-of-Sync Counter Bits 0 to 7 (FOS0 to FOS7). FOS0 is the LSB of the 16-bit frames out-of-sync count.

Register Name: **TR.EBCR1**
 Register Description: **E-Bit Count Register 1**
 Register Address: **48h**

Bit #	7	6	5	4	3	2	1	0
Name	EB15	EB14	EB13	EB12	EB11	EB10	EB9	EB8
Default	0	0	0	0	0	0	0	0

Bits 0 – 7: E-Bit Counter Bits 8 to 15 (EB8 to EB15). EB15 is the MSB of the 16-bit E-bit count.

Register Name: **TR.EBCR2**
 Register Description: **E-Bit Count Register 2**
 Register Address: **49h**

Bit #	7	6	5	4	3	2	1	0
Name	EB7	EB6	EB5	EB4	EB3	EB2	EB1	EB0
Default	0	0	0	0	0	0	0	0

Bits 0 – 7: E-Bit Counter Bits 0 to 7 (EB0 to EB7). EB0 is the LSB of the 16-bit E-bit count.

Register Name: **TR.LBCR**
 Register Description: **Loopback Control Register**
 Register Address: **4Ah**

Bit #	7	6	5	4	3	2	1	0
Name	—	—	—	LIUC	LLB	RLB	PLB	FLB
Default	0	0	0	0	0	0	0	0

Bit 4: Line Interface Unit Mux Control (LIUC). This is a software version of the LIUC pin. When the LIUC pin is connected high, the LIUC bit has control. When the LIUC pin is connected low, the framer and LIU are separated and the LIUC bit has no effect.

0 = LIU internally connected to framer.

1 = LIU disconnected from framer. Use TPOSI/TNEGI/TDCLKI/RPOSI/RNEGI/RDCLKI pins

LIUC Pin	LIUC Bit	Condition
0	0	LIU and framer separated
0	1	LIU and framer separated
1	0	LIU and framer connected
1	1	LIU and framer separated

Bit 3: Local Loopback (LLB). When this bit is set to 1, data continues to be transmitted as normal through the transmit side of the transceiver. Data being received at RTIP and RRING are replaced with the data being transmitted. Data in this loopback passes through the jitter attenuator. See [Figure 6-3](#) for more details.

Bit 2: Remote Loopback (RLB). When this bit is set to 1, data input by the RPOSI and RNEGI pins is transmitted back to the TPOSO and TNEGO pins. Data continues to pass through the receive-side framer of the transceiver as it would normally. Data from the transmit-side formatter is ignored. See [Figure 6-2](#) for more details.

Bit 1: Payload Loopback (PLB). When set to 1, payload loopback is enabled and the following occurs:

- 1) Data is transmitted from the TPOSO and TNEGO pins synchronous with RCLKO instead of TCLKT.
- 2) All the receive side signals continue to operate normally.
- 3) Data at the TSERI, TDATA, and TSIG pins is ignored.

T1 Mode: Normally, this loopback is only enabled when ESF framing is being performed but can also be enabled in D4 framing applications. The transceiver loops the 192 bits of payload data (with BPVs corrected) from the receive section back to the transmit section. The FPS framing pattern, CRC6 calculation, and the FDL bits are not looped back; they are reinserted by the transceiver.

E1 Mode: The transceiver loops the 248 bits of payload data (with BPVs corrected) from the receive section back to the transmit section. The transmit section modifies the payload as if it was input at TSERI. The FAS word; Si, Sa, and E bits; and CRC4 are not looped back; they are reinserted by the transceiver.

Bit 0: Framer Loopback (FLB). When this bit is set to 1, the transceiver loops data from the transmit side back to the receive side. When FLB is enabled, the following occurs:

- 1) T1 Mode: An unframed all-ones code is transmitted at TPOSO and TNEGO.
E1 Mode: Normal data is transmitted at TPOSO and TNEGO.
- 2) Data at RPOSI and RNEGI is ignored.
- 3) All receive-side signals take on timing synchronous with TCLKT instead of RDCLKI.

Please note that it is not acceptable to have RCLKO connected to TCLKT during this loopback because this causes an unstable condition.

Register Name: **TR.PCLR1**
 Register Description: **Per-Channel Loopback Enable Register 1**
 Register Address: **4Bh**

Bit #	7	6	5	4	3	2	1	0
Name	CH8	CH7	CH6	CH5	CH4	CH3	CH2	CH1
Default	0	0	0	0	0	0	0	0

Bits 0 – 7: Per-Channel Loopback Enable for Channels 1 to 8 (CH1 to CH8)

0 = loopback disabled

1 = enable loopback; source data from the corresponding receive channel

Register Name: **TR.PCLR2**
 Register Description: **Per-Channel Loopback Enable Register 2**
 Register Address: **4Ch**

Bit #	7	6	5	4	3	2	1	0
Name	CH16	CH15	CH14	CH13	CH12	CH11	CH10	CH9
Default	0	0	0	0	0	0	0	0

Bits 0 – 7: Per-Channel Loopback Enable for Channels 9 to 16 (CH9 to CH16)

0 = loopback disabled

1 = enable loopback; source data from the corresponding receive channel

Register Name: **TR.PCLR3**
 Register Description: **Per-Channel Loopback Enable Register 3**
 Register Address: **4Dh**

Bit #	7	6	5	4	3	2	1	0
Name	CH24	CH23	CH22	CH21	CH20	CH19	CH18	CH17
Default	0	0	0	0	0	0	0	0

Bits 0 – 7: Per-Channel Loopback Enable for Channels 17 to 24 (CH17 to CH24)

0 = loopback disabled

1 = enable loopback; source data from the corresponding receive channel

Register Name: **TR.PCLR4**
 Register Description: **Per-Channel Loopback Enable Register 4**
 Register Address: **4Eh**

Bit #	7	6	5	4	3	2	1	0
Name	CH32	CH31	CH30	CH29	CH28	CH27	CH26	CH25
Default	0	0	0	0	0	0	0	0

Bits 0 – 7: Per-Channel Loopback Enable for Channels 25 to 32 (CH25 to CH32)

0 = loopback disabled

1 = enable loopback; source data from the corresponding receive channel

Register Name: **TR.ESCR**
 Register Description: **Elastic Store Control Register**
 Register Address: **4Fh**

Bit #	7	6	5	4	3	2	1	0
Name	TESALGN	TESR	TESMDM	TESE	RESALGN	RESR	RESMDM	RESE
Default	0	0	0	0	0	0	0	0

Bit 7: Transmit Elastic Store Align (TESALGN). Setting this bit from a 0 to a 1 forces the transmit elastic store's write/read pointers to a minimum separation of half a frame. No action is taken if the pointer separation is already greater or equal to half a frame. If pointer separation is less than half a frame, the command is executed and the data is disrupted. It should be toggled after TSYCLK has been applied and is stable. It must be cleared and set again for a subsequent align. See Section [10.12.3](#) for details.

Bit 6: Transmit Elastic Store Reset (TESR). Setting this bit from a 0 to a 1 forces the read and write pointers into opposite frames, maximizing the delay through the transmit elastic store. Transmit data is lost during the reset. It should be toggled after TSYCLK has been applied and is stable. See Section [10.12.3](#) for details. Do not leave this bit set HIGH.

Bit 5: Transmit Elastic Store Minimum-Delay Mode (TESMDM). See Section [10.12.4](#) for details.

0 = elastic stores operate at full two-frame depth

1 = elastic stores operate at 32-bit depth

Bit 4: Transmit Elastic Store Enable (TESE)

0 = elastic store is bypassed

1 = elastic store is enabled

Bit 3: Receive Elastic Store Align (RESALGN). Setting this bit from a 0 to a 1 forces the receive elastic store's write/read pointers to a minimum separation of half a frame. No action is taken if the pointer separation is already greater or equal to half a frame. If pointer separation is less than half a frame, the command is executed and the data is disrupted. It should be toggled after RSYCLK has been applied and is stable. Must be cleared and set again for a subsequent align. See Section [10.12.3](#) for details.

Bit 2: Receive Elastic Store Reset (RESR). Setting this bit from a 0 to a 1 forces the read and write pointers into opposite frames, maximizing the delay through the receive elastic store. It should be toggled after RSYCLK has been applied and is stable. See Section [10.12.3](#) for details. Do not leave this bit set HIGH.

Bit 1: Receive Elastic Store Minimum-Delay Mode (RESMDM). See Section [10.12.4](#) for details.

0 = elastic stores operate at full two-frame depth

1 = elastic stores operate at 32-bit depth

Bit 0: Receive Elastic Store Enable (RESE)

0 = elastic store is bypassed

1 = elastic store is enabled

Register Name: **TR.TS1 to TR.TS16**
 Register Description: **Transmit Signaling Registers (E1 Mode, CAS Format)**
 Register Address: **50h to 5Fh**

(MSB)							(LSB)	
0	0	0	0	X	Y	X	X	TS1
CH2-A	CH2-B	CH2-C	CH2-D	CH1-A	CH1-B	CH1-C	CH1-D	TS2
CH4-A	CH4-B	CH4-C	CH4-D	CH3-A	CH3-B	CH3-C	CH3-D	TS3
CH6-A	CH6-B	CH6-C	CH6-D	CH5-A	CH5-B	CH5-C	CH5-D	TS4
CH8-A	CH8-B	CH8-C	CH8-D	CH7-A	CH7-B	CH7-C	CH7-D	TS5
CH10-A	CH10-B	CH10-C	CH10-D	CH9-A	CH9-B	CH9-C	CH9-D	TS6
CH12-A	CH12-B	CH12-C	CH12-D	CH11-A	CH11-B	CH11-C	CH11-D	TS7
CH14-A	CH14-B	CH14-C	CH14-D	CH13-A	CH13-B	CH13-C	CH13-D	TS8
CH16-A	CH16-B	CH16-C	CH16-D	CH15-A	CH15-B	CH15-C	CH15-D	TS9
CH18-A	CH18-B	CH18-C	CH18-D	CH17-A	CH17-B	CH17-C	CH17-D	TS10
CH20-A	CH20-B	CH20-C	CH20-D	CH19-A	CH19-B	CH19-C	CH19-D	TS11
CH22-A	CH22-B	CH22-C	CH22-D	CH21-A	CH21-B	CH21-C	CH21-D	TS12
CH24-A	CH24-B	CH24-C	CH24-D	CH23-A	CH23-B	CH23-C	CH23-D	TS13
CH26-A	CH26-B	CH26-C	CH26-D	CH25-A	CH25-B	CH25-C	CH25-D	TS14
CH28-A	CH28-B	CH28-C	CH28-D	CH27-A	CH27-B	CH27-C	CH27-D	TS15
CH30-A	CH30-B	CH30-C	CH30-D	CH29-A	CH29-B	CH29-C	CH29-D	TS16

Register Name: **TR.TS1 to TR.TS16**
 Register Description: **Transmit Signaling Registers (E1 Mode, CCS Format)**
 Register Address: **50h to 5Fh**

(MSB)							(LSB)	
1	2	3	4	5	6	7	8	TS1
9	10	11	12	13	14	15	16	TS2
17	18	19	20	21	22	23	24	TS3
25	26	27	28	29	30	31	32	TS4
33	34	35	36	37	38	39	40	TS5
41	42	43	44	45	46	47	48	TS6
49	50	51	52	53	54	55	56	TS7
57	58	59	60	61	62	63	64	TS8
65	66	67	68	69	70	71	72	TS9
73	74	75	76	77	78	79	80	TS10
81	82	83	84	85	86	87	88	TS11
89	90	91	92	93	94	95	96	TS12
97	98	99	100	101	102	103	104	TS13
105	106	107	108	109	110	111	112	TS14
113	114	115	116	117	118	119	120	TS15
121	122	123	124	125	126	127	128	TS16

Register Name: **TR.TS1 to TR.TS12**
 Register Description: **Transmit Signaling Registers (T1 Mode, ESF Format)**
 Register Address: **50h to 5Bh**

(MSB)							(LSB)	
CH2-A	CH2-B	CH2-C	CH2-D	CH1-A	CH1-B	CH1-C	CH1-D	TS1
CH4-A	CH4-B	CH4-C	CH4-D	CH3-A	CH3-B	CH3-C	CH3-D	TS2
CH6-A	CH6-B	CH6-C	CH6-D	CH5-A	CH5-B	CH5-C	CH5-D	TS3
CH8-A	CH8-B	CH8-C	CH8-D	CH7-A	CH7-B	CH7-C	CH7-D	TS4
CH10-A	CH10-B	CH10-C	CH10-D	CH9-A	CH9-B	CH9-C	CH9-D	TS5
CH12-A	CH12-B	CH12-C	CH12-D	CH11-A	CH11-B	CH11-C	CH11-D	TS6
CH14-A	CH14-B	CH14-C	CH14-D	CH13-A	CH13-B	CH13-C	CH13-D	TS7
CH16-A	CH16-B	CH16-C	CH16-D	CH15-A	CH15-B	CH15-C	CH15-D	TS8
CH18-A	CH18-B	CH18-C	CH18-D	CH17-A	CH17-B	CH17-C	CH17-D	TS9
CH20-A	CH20-B	CH20-C	CH20-D	CH19-A	CH19-B	CH19-C	CH19-D	TS10
CH22-A	CH22-B	CH22-C	CH22-D	CH21-A	CH21-B	CH21-C	CH21-D	TS11
CH24-A	CH24-B	CH24-C	CH24-D	CH23-A	CH23-B	CH23-C	CH23-D	TS12

Register Name: **TR.TS1 to TR.TS12**
 Register Description: **Transmit Signaling Registers (T1 Mode, D4 Format)**
 Register Address: **50h to 5Bh**

(MSB)							(LSB)	
CH2-A	CH2-B	CH2-A	CH2-B	CH1-A	CH1-B	CH1-A	CH1-B	TS1
CH4-A	CH4-B	CH4-A	CH4-B	CH3-A	CH3-B	CH3-A	CH3-B	TS2
CH6-A	CH6-B	CH6-A	CH6-B	CH5-A	CH5-B	CH5-A	CH5-B	TS3
CH8-A	CH8-B	CH8-A	CH8-B	CH7-A	CH7-B	CH7-A	CH7-B	TS4
CH10-A	CH10-B	CH10-A	CH10-B	CH9-A	CH9-B	CH9-A	CH9-B	TS5
CH12-A	CH12-B	CH12-A	CH12-B	CH11-A	CH11-B	CH11-A	CH11-B	TS6
CH14-A	CH14-B	CH14-A	CH14-B	CH13-A	CH13-B	CH13-A	CH13-B	TS7
CH16-A	CH16-B	CH16-A	CH16-B	CH15-A	CH15-B	CH15-A	CH15-B	TS8
CH18-A	CH18-B	CH18-A	CH18-B	CH17-A	CH17-B	CH17-A	CH17-B	TS9
CH20-A	CH20-B	CH20-A	CH20-B	CH19-A	CH19-B	CH19-A	CH19-B	TS10
CH22-A	CH22-B	CH22-A	CH22-B	CH21-A	CH21-B	CH21-A	CH21-B	TS11
CH24-A	CH24-B	CH24-A	CH24-B	CH23-A	CH23-B	CH23-A	CH23-B	TS12

Note: In D4 format, TR.TS1– TR.TS12 contain signaling data for two frames. Bold type indicates data for second frame.

Register Name: **TR.RS1 to TR.RS12**
 Register Description: **Receive Signaling Registers (T1 Mode, ESF Format)**
 Register Address: **60h to 6Bh**

(MSB)							(LSB)	
CH2-A	CH2-B	CH2-C	CH2-D	CH1-A	CH1-B	CH1-C	CH1-D	RS1
CH4-A	CH4-B	CH4-C	CH4-D	CH3-A	CH3-B	CH3-C	CH3-D	RS2
CH6-A	CH6-B	CH6-C	CH6-D	CH5-A	CH5-B	CH5-C	CH5-D	RS3
CH8-A	CH8-B	CH8-C	CH8-D	CH7-A	CH7-B	CH7-C	CH7-D	RS4
CH10-A	CH10-B	CH10-C	CH10-D	CH9-A	CH9-B	CH9-C	CH9-D	RS5
CH12-A	CH12-B	CH12-C	CH12-D	CH11-A	CH11-B	CH11-C	CH11-D	RS6
CH14-A	CH14-B	CH14-C	CH14-D	CH13-A	CH13-B	CH13-C	CH13-D	RS7
CH16-A	CH16-B	CH16-C	CH16-D	CH15-A	CH15-B	CH15-C	CH15-D	RS8
CH18-A	CH18-B	CH18-C	CH18-D	CH17-A	CH17-B	CH17-C	CH17-D	RS9
CH20-A	CH20-B	CH20-C	CH20-D	CH19-A	CH19-B	CH19-C	CH19-D	RS10
CH22-A	CH22-B	CH22-C	CH22-D	CH21-A	CH21-B	CH21-C	CH21-D	RS11
CH24-A	CH24-B	CH24-C	CH24-D	CH23-A	CH23-B	CH23-C	CH23-D	RS12

Register Name: **TR.RS1 to TR.RS12**
 Register Description: **Receive Signaling Registers (T1 Mode, D4 Format)**
 Register Address: **60h to 6Bh**

(MSB)							(LSB)	
CH2-A	CH2-B	CH2-A	CH2-B	CH1-A	CH1-B	CH1-A	CH1-B	RS1
CH4-A	CH4-B	CH4-A	CH4-B	CH3-A	CH3-B	CH3-A	CH3-B	RS2
CH6-A	CH6-B	CH6-A	CH6-B	CH5-A	CH5-B	CH5-A	CH5-B	RS3
CH8-A	CH8-B	CH8-A	CH8-B	CH7-A	CH7-B	CH7-A	CH7-B	RS4
CH10-A	CH10-B	CH10-A	CH10-B	CH9-A	CH9-B	CH9-A	CH9-B	RS5
CH12-A	CH12-B	CH12-A	CH12-B	CH11-A	CH11-B	CH11-A	CH11-B	RS6
CH14-A	CH14-B	CH14-A	CH14-B	CH13-A	CH13-B	CH13-A	CH13-B	RS7
CH16-A	CH16-B	CH16-A	CH16-B	CH15-A	CH15-B	CH15-A	CH15-B	RS8
CH18-A	CH18-B	CH18-A	CH18-B	CH17-A	CH17-B	CH17-A	CH17-B	RS9
CH20-A	CH20-B	CH20-A	CH20-B	CH19-A	CH19-B	CH19-A	CH19-B	RS10
CH22-A	CH22-B	CH22-A	CH22-B	CH21-A	CH21-B	CH21-A	CH21-B	RS11
CH24-A	CH24-B	CH24-A	CH24-B	CH23-A	CH23-B	CH23-A	CH23-B	RS12

Note: In D4 format, TR.TS1– TR.TS12 contain signaling data for two frames. Bold type indicates data for second frame.

Register Name: **TR.RS1 to TR.RS16**
 Register Description: **Receive Signaling Registers (E1 Mode, CAS Format)**
 Register Address: **60h to 6Fh**

(MSB)							(LSB)	
0	0	0	0	X	Y	X	X	RS1
CH2-A	CH2-B	CH2-C	CH2-D	CH1-A	CH1-B	CH1-C	CH1-D	RS2
CH4-A	CH4-B	CH4-C	CH4-D	CH3-A	CH3-B	CH3-C	CH3-D	RS3
CH6-A	CH6-B	CH6-C	CH6-D	CH5-A	CH5-B	CH5-C	CH5-D	RS4
CH8-A	CH8-B	CH8-C	CH8-D	CH7-A	CH7-B	CH7-C	CH7-D	RS5
CH10-A	CH10-B	CH10-C	CH10-D	CH9-A	CH9-B	CH9-C	CH9-D	RS6
CH12-A	CH12-B	CH12-C	CH12-D	CH11-A	CH11-B	CH11-C	CH11-D	RS7
CH14-A	CH14-B	CH14-C	CH14-D	CH13-A	CH13-B	CH13-C	CH13-D	RS8
CH16-A	CH16-B	CH16-C	CH16-D	CH15-A	CH15-B	CH15-C	CH15-D	RS9
CH18-A	CH18-B	CH18-C	CH18-D	CH17-A	CH17-B	CH17-C	CH17-D	RS10
CH20-A	CH20-B	CH20-C	CH20-D	CH19-A	CH19-B	CH19-C	CH19-D	RS11
CH22-A	CH22-B	CH22-C	CH22-D	CH21-A	CH21-B	CH21-C	CH21-D	RS12
CH24-A	CH24-B	CH24-C	CH24-D	CH23-A	CH23-B	CH23-C	CH23-D	RS13
CH26-A	CH26-B	CH26-C	CH26-D	CH25-A	CH25-B	CH25-C	CH25-D	RS14
CH28-A	CH28-B	CH28-C	CH28-D	CH27-A	CH27-B	CH27-C	CH27-D	RS15
CH30-A	CH30-B	CH30-C	CH30-D	CH29-A	CH29-B	CH29-C	CH29-D	RS16

Register Name: **TR.RS1 to TR.RS16**
 Register Description: **Receive Signaling Registers (E1 Mode, CCS Format)**
 Register Address: **60h to 6Fh**

(MSB)							(LSB)	
1	2	3	4	5	6	7	8	RS1
9	10	11	12	13	14	15	16	RS2
17	18	19	20	21	22	23	24	RS3
25	26	27	28	29	30	31	32	RS4
33	34	35	36	37	38	39	40	RS5
41	42	43	44	45	46	47	48	RS6
49	50	51	52	53	54	55	56	RS7
57	58	59	60	61	62	63	64	RS8
65	66	67	68	69	70	71	72	RS9
73	74	75	76	77	78	79	80	RS10
81	82	83	84	85	86	87	88	RS11
89	90	91	92	93	94	95	96	RS12
97	98	99	100	101	102	103	104	RS13
105	106	107	108	109	110	111	112	RS14
113	114	115	116	117	118	119	120	RS15
121	122	123	124	125	126	127	128	RS16

Register Name: **TR.CCR1**
 Register Description: **Common Control Register 1**
 Register Address: **70h**

Bit #	7	6	5	4	3	2	1	0
Name	MCLKS	CRC4R	SIE	ODM	DICAI	TCSS1	TCSS0	RLOSF
Default	0	0	0	0	0	0	0	0

Bit 7: MCLK Source (MCLKS). Selects the source of MCLK

- 0 = MCLK is source from the MCLK pin
- 1 = MCLK is source from the TSYSCLK pin

Bit 6: CRC-4 Recalculate (CRC4R)

- 0 = transmit CRC-4 generation and insertion operates in normal mode
- 1 = transmit CRC-4 generation operates according to G.706 intermediate path recalculation method

Bit 5: Signaling Integration Enable (SIE)

- 0 = signaling changes of state reported on any change in selected channels
- 1 = signaling must be stable for three multiframes in order for a change of state to be reported

Bit 4: Output Data Mode (ODM)

- 0 = pulses at TPOSO and TNEGO are one full TCLKO period wide
- 1 = pulses at TPOSO and TNEGO are one-half TCLKO period wide

Bit 3: Disable Idle Code Auto Increment (DICAI). Selects/deselects the auto-increment feature for the transmit and receive idle code array address register. See Section [10.10](#).

- 0 = addresses in TR.IAAR register automatically increment on every read/write operation to the TR.PCICR register
- 1 = addresses in TR.IAAR register do not automatically increment

Bit 2: Transmit Clock Source Select Bit 0 (TCSS1)

TCSS1	TCSS0	Transmit Clock Source
0	0	The TCLKT pin is always the source of transmit clock.
0	1	Switch to the clock present at RCLKO when the signal at the TCLKT pin fails to transition after 1 channel time.
1	0	Use the scaled signal present at MCLK as the transmit clock. The TCLKT pin is ignored.
1	1	Use the signal present at RCLKO as the transmit clock. The TCLKT pin is ignored.

Bit 1: Transmit Clock Source Select Bit 0 (TCSS0)

Bit 0: Function of the RLOS/LOTC Output (RLOSF)

- 0 = receive loss of sync (RLOS)
- 1 = loss-of-transmit clock (LOTC)

Register Name: **TR.CCR2**
 Register Description: **Common Control Register 2**
 Register Address: **71h**

Bit #	7	6	5	4	3	2	1	0
Name	—	—	—	—	—	BPCS1	BPCS0	BPEN
Default	0	0	0	0	0	0	0	0

Bits 1 – 2: Backplane Clock Selects (BPCS0, BPCS1)

BPCS1	BPCS0	BPCLK Frequency (MHz)
0	0	16.384
0	1	8.192
1	0	4.096
1	1	2.048

Bit 0: Backplane Clock Enable (BPEN)

- 0 = disable BPCLK pin (pin held at logic 0)
- 1 = enable BPCLK pin

Register Name: **TR.CCR3**
 Register Description: **Common Control Register 3**
 Register Address: **72h**

Bit #	7	6	5	4	3	2	1	0
Name	TMSS	INTDIS	—	—	TDATFMT	TGPCKEN	RDATFMT	RGPCKEN
Default	0	0	0	0	0	0	0	0

Bit 7: Transmit Multiframe Sync Source (TMSS). Should be set = 0 only when transmit hardware signaling is enabled.

- 0 = elastic store is source of multiframe sync
- 1 = framer or TSYNC pin is source of multiframe sync

Bit 6: Interrupt Disable (INTDIS). This bit is convenient for disabling interrupts without altering the various interrupt mask register settings.

- 0 = interrupts are enabled according to the various mask register settings
- 1 = interrupts are disabled regardless of the mask register settings

Bit 3: Transmit Channel-Data Format (TDATFMT)

- 0 = 64kbps (data contained in all 8 bits)
- 1 = 56kbps (data contained in seven out of the 8 bits)

Bit 2: Transmit Gapped-Clock Enable (TGPCKEN)

- 0 = TCHCLK functions normally
- 1 = enable gapped bit-clock output on TCHCLK

Bit 1: Receive Channel-Data Format (RDATFMT)

- 0 = 64kbps (data contained in all 8 bits)
- 1 = 56kbps (data contained in seven out of the 8 bits)

Bit 0: Receive Gapped-Clock Enable (RGPKEN)

- 0 = RCHCLK functions normally
- 1 = enable gapped bit-clock output on RCHCLK

Register Name: **TR.CCR4**
 Register Description: **Common Control Register 4**
 Register Address: **73h**

Bit #	7	6	5	4	3	2	1	0
Name	RLT3	RLT2	RLT1	RLT0	—	—	—	—
Default	0	0	0	0	0	0	0	0

Bits 4 – 7: Receive Level Threshold Bits (RLT0 to RLT3)

RLT3	RLT2	RLT1	RLT0	Receive Level (dB)
0	0	0	0	Greater than -2.5
0	0	0	1	-2.5
0	0	1	0	-5.0
0	0	1	1	-7.5
0	1	0	0	-10.0
0	1	0	1	-12.5
0	1	1	0	-15.0
0	1	1	1	-17.5
1	0	0	0	-20.0
1	0	0	1	-22.5
1	0	1	0	-25.0
1	0	1	1	-27.5
1	1	0	0	-30.0
1	1	0	1	-32.5
1	1	1	0	-35.0
1	1	1	1	Less than -37.5

Register Name: **TR.TDS0SEL**
 Register Description: **Transmit Channel Monitor Select**
 Register Address: **74h**

Bit #	7	6	5	4	3	2	1	0
Name	—	—	—	TCM4	TCM3	TCM2	TCM1	TCM0
Default	0	0	0	0	0	0	0	0

Bits 0 – 4: Transmit Channel Monitor Bits (TCM0 to TCM4). TCM0 is the LSB of a 5-bit channel select that determines which transmit channel data appear in the TR.TDS0M register.

Register Name: **TR.TDS0M**
 Register Description: **Transmit DS0 Monitor Register**
 Register Address: **75h**

Bit #	7	6	5	4	3	2	1	0
Name	B1	B2	B3	B4	B5	B6	B7	B8
Default	0	0	0	0	0	0	0	0

Bits 0 – 7: Transmit DS0 Channel Bits (B1 to B8). Transmit channel data that has been selected by the transmit channel monitor select register. B8 is the LSB of the DS0 channel (last bit to be transmitted).

Register Name: **TR.RDS0SEL**
 Register Description: **Receive Channel Monitor Select**
 Register Address: **76h**

Bit #	7	6	5	4	3	2	1	0
Name	—	—	—	RCM4	RCM3	RCM2	RCM1	RCM0
Default	0	0	0	0	0	0	0	0

Bits 0 – 4: Receive Channel Monitor Bits (RCM0 to RCM4). RCM0 is the LSB of a 5-bit channel select that determines which receive DS0 channel data appear in the TR.RDS0M register.

Register Name: **TR.RDS0M**
 Register Description: **Receive DS0 Monitor Register**
 Register Address: **77h**

Bit #	7	6	5	4	3	2	1	0
Name	B1	B2	B3	B4	B5	B6	B7	B8
Default	0	0	0	0	0	0	0	0

Bits 0 – 7: Receive DS0 Channel Bits (B1 to B8). Receive channel data that has been selected by the receive channel monitor select register. B8 is the LSB of the DS0 channel (last bit to be received).

Register Name: **TR.LIC1**
 Register Description: **Line Interface Control 1**
 Register Address: **78h**

Bit #	7	6	5	4	3	2	1	0
Name	L2	L1	L0	EGL	JAS	JABDS	DJA	TPD
Default	0	0	0	0	0	0	0	0

Bits 5 – 7: Line Build-Out Select (L0 to L2). When using the internal termination, the user needs only to select 000 for 75Ω operation or 001 for 120Ω operation below. This selects the proper voltage levels for 75Ω or 120Ω operation. Using TT0 and TT1 of the TR.LICR4 register, the user can then select the proper internal source termination. Line build-outs 100 and 101 are for backwards compatibility with older products only.

E1 Mode

L2	L1	L0	Application	N (1)	Return Loss	Rt (1) (Ω)
0	0	0	75Ω normal	1:2	NM	0
0	0	1	120Ω normal	1:2	NM	0
1	0	0	75Ω with high return loss*	1:2	21dB	6.2
1	0	1	120Ω with high return loss*	1:2	21dB	11.6

*TT0 and TT1 of LIC4 register must be set to 0 in this configuration.

T1 Mode

L2	L1	L0	Application	N (1)	Return Loss	Rt (1) (Ω)
0	0	0	DSX-1 (0ft to 133ft) / 0dB CSU	1:2	NM	0
0	0	1	DSX-1 (133ft to 266ft)	1:2	NM	0
0	1	0	DSX-1 (266ft to 399ft)	1:2	NM	0
0	1	1	DSX-1 (399ft to 533ft)	1:2	NM	0
1	0	0	DSX-1 (533ft to 655ft)	1:2	NM	0
1	0	1	-7.5dB CSU	1:2	NM	0
1	1	0	-15dB CSU	1:2	NM	0
1	1	1	-22.5dB CSU	1:2	NM	0

Bit 4: Receive Equalizer Gain Limit (EGL). This bit controls the sensitivity of the receive equalizer.

T1 Mode

0 = -36dB (long haul)

1 = -15dB (limited long haul)

E1 Mode

0 = -12dB (short haul)

1 = -43dB (long haul)

Bit 3: Jitter Attenuator Select (JAS)

0 = place the jitter attenuator on the receive side

1 = place the jitter attenuator on the transmit side

Bit 2: Jitter Attenuator Buffer Depth Select (JABDS)

0 = 128 bits

1 = 32 bits (use for delay-sensitive applications)

Bit 1: Disable Jitter Attenuator (DJA)

0 = jitter attenuator enabled

1 = jitter attenuator disabled

Bit 0: Transmit Power-Down (TPD)

0 = powers down the transmitter and tri-states the TTIP and TRING pins

1 = normal transmitter operation

Register Name: **TR.TLBC**
 Register Description: **Transmit Line Build-Out Control**
 Register Address: **7Dh**

Bit #	7	6	5	4	3	2	1	0
Name	—	AGCE	GC5	GC4	GC3	GC2	GC1	GC0
Default	0	0	0	0	0	0	0	0

Bit 6: Automatic Gain Control Enable (AGCE).

0 = use Transmit AGC, TR.TLBC bits 0–5 are “don’t care”

1 = do not use Transmit AGC, TR.TLBC bits 0–5 set nominal level

Bits 0–5: Gain Control Bits (GC0–GC5). The GC0 through GC5 bits control the gain setting for the nonautomatic gain mode. Use the tables below for setting the recommended values. The LB (line build-out) column refers to the value in the L0–L2 bits in TR.LIC1 (Line Interface Control 1) register.

NETWORK MODE	LB	GC5	GC4	GC3	GC2	GC1	GC0
T1, Impedance Match Off	0	1	0	0	1	1	0
	1	0	1	1	0	1	1
	2	0	1	1	0	1	0
	3	1	0	0	0	0	0
	4	1	0	0	1	1	1
	5	1	0	0	1	1	1
	6	0	1	0	0	1	1
T1, Impedance Match On	0	0	1	1	1	1	0
	1	0	1	0	1	0	1
	2	0	1	0	1	0	1
	3	0	1	1	0	1	0
	4	1	0	0	0	1	0
	5	1	0	0	0	0	0
	6	0	0	1	1	0	0
E1, Impedance Match Off	0	1	0	0	0	0	1
	1	1	0	0	0	0	1
	4	1	0	1	0	1	0
	5	1	0	1	0	0	0
E1, Impedance Match On	0	0	1	1	0	1	0
	1	0	1	1	0	1	0

Register Name: **TR.LIC2**
 Register Description: **Line Interface Control 2**
 Register Address: **79h**

Bit #	7	6	5	4	3	2	1	0
Name	ETS	LIRST	IBPV	TUA1	JAMUX	—	SCLD	CLDS
Default	0	0	0	0	0	0	0	0

Bit 7: E1/T1 Select (ETS)

0 = T1 mode selected

1 = E1 mode selected

Bit 6: Line Interface Reset (LIRST). Setting this bit from a 0 to a 1 initiates an internal reset that resets the clock recovery state machine and recenters the jitter attenuator. Normally this bit is only toggled on power-up. Must be cleared and set again for a subsequent reset.

Bit 5: Insert BPV (IBPV). A 0-to-1 transition on this bit causes a single BPV to be inserted into the transmit data stream. Once this bit has been toggled from a 0 to a 1, the device waits for the next occurrence of three consecutive 1s to insert the BPV. This bit must be cleared and set again for a subsequent error to be inserted.

Bit 4: Transmit Unframed All Ones (TUA1). The polarity of this bit is set such that the device transmits an all-ones pattern on power-up or device reset. This bit must be set to a 1 to allow the device to transmit data. The transmission of this data pattern is always timed off of the JACLK.

0 = transmit all ones at TTIP and TRING

1 = transmit data normally

Bit 3: Jitter Attenuator Mux (JAMUX). Controls the source for JACLK.

0 = JACLK sourced from MCLK (2.048MHz or 1.544MHz at MCLK)

1 = JACLK sourced from internal PLL (2.048MHz at MCLK)

Bit 1: Short-Circuit Limit Disable (ETS = 1) (SCLD). Controls the 50mA (RMS) current limiter.

0 = enable 50mA current limiter

1 = disable 50mA current limiter

Bit 0: Custom Line Driver Select (CLDS). Setting this bit to a 1 redefines the operation of the transmit line driver. When this bit is set to a 1 and TR.LIC1.5 = TR.LIC1.6 = TR.LIC1.7 = 0, the device generates a square wave at the TTIP and TRING outputs instead of a normal waveform. When this bit is set to a 1 and TR.LIC1.5 = TR.LIC1.6 = TR.LIC1.7 ≠ 0, the device forces TTIP and TRING outputs to become open-drain drivers instead of their normal push-pull operation. This bit should be set to 0 for normal operation of the device.

Register Name: **TR.LIC3**
 Register Description: **Line Interface Control 3**
 Register Address: **7Ah**

Bit #	7	6	5	4	3	2	1	0
Name	—	TCES	RCES	MM1	MM0	RSCLKE	TSCLKE	TAOZ
Default	0	0	0	0	0	0	0	0

Bit 6: Transmit-Clock Edge Select (TCES). Selects which TDCLKI edge to sample TPOSI and TNEGI.
 0 = sample TPOSI and TNEGI on falling edge of TDCLKI
 1 = sample TPOSI and TNEGI on rising edge of TDCLKI

Bit 5: Receive-Clock Edge Select (RCES). Selects which RDCLKO edge to update RPOSO and RNEGO.
 0 = update RPOSO and RNEGO on rising edge of RDCLKO
 1 = update RPOSO and RNEGO on falling edge of RDCLKO

Bits 3 – 4: Monitor Mode (MM0 to MM1)

MM1	MM0	Internal Linear Gain Boost (dB)
0	0	Normal operation (no boost)
0	1	20
1	0	26
1	1	32

Bit 2: Receive Synchronization G.703 Clock Enable (RSCLKE)
 0 = disable 1.544MHz (T1)/2.048MHz (E1) synchronization receive mode
 1 = enable 1.544MHz (T1)/2.048MHz (E1) synchronization receive mode

Bit 1: Transmit Synchronization G.703 Clock Enable (TSCLKE)
 0 = disable 1.544MHz (T1)/2.048MHz (E1) transmit synchronization clock
 1 = enable 1.544MHz (T1)/2.048MHz (E1) transmit synchronization clock

Bit 0: Transmit Alternate Ones and Zeros (TAOZ). Transmit a ...101010... pattern (customer disconnect indication signal) at TTIP and TRING. The transmission of this data pattern is always timed off of TCLKT.
 0 = disabled
 1 = enabled

Register Name: **TR.LIC4**
 Register Description: **Line Interface Control 4**
 Register Address: **7Bh**

Bit #	7	6	5	4	3	2	1	0
Name	CMIE	CMII	MPS1	MPS0	TT1	TT0	RT1	RT0
Default	0	0	0	0	0	0	0	0

Bit 7: CMI Enable (CMIE)

0 = disable CMI mode

1 = enable CMI mode

Bit 6: CMI Invert (CMII)

0 = CMI normal at TTIP and RTIP

1 = invert CMI signal at TTIP and RTIP

Bits 4 – 5: MCLK Prescaler**T1 Mode:**

MCLK (MHz)	MPS1	MPS0	JAMUX (TR.LIC2.3)
1.544	0	0	0
3.088	0	1	0
6.176	1	0	0
12.352	1	1	0
2.048	0	0	1
4.096	0	1	1
8.192	1	0	1
16.384	1	1	1

E1 Mode:

MCLK (MHz)	MPS1	MPS0	JAMUX (TR.LIC2.3)
2.048	0	0	0
4.096	0	1	0
8.192	1	0	0
16.384	1	1	0

Bits 2 – 3: Transmit Termination Select (TT0, TT1)

TT1	TT0	Internal Transmit-Termination Configuration
0	0	Internal transmit-side termination disabled
0	1	Internal transmit -side 75Ω enabled
1	0	Internal transmit -side 100Ω enabled
1	1	Internal transmit -side 120Ω enabled

Bits 0 – 1: Receive Termination Select (RT0, RT1)

RT1	RT0	Internal Receive-Termination Configuration
0	0	Internal receive-side termination disabled
0	1	Internal receive-side 75Ω enabled
1	0	Internal receive-side 100Ω enabled
1	1	Internal receive-side 120Ω enabled

Register Name: **TR.IAAR**
 Register Description: **Idle Array Address Register**
 Register Address: **7Eh**

Bit #	7	6	5	4	3	2	1	0
Name	GRIC	GTIC	IAA5	IAA4	IAA3	IAA2	IAA1	IAA0
Default	0	0	0	0	0	0	0	0

Bit 7: Global Receive-Idle Code (GRIC). Setting this bit causes all receive channels to be set to the idle code written to the TR.PCICR register. This bit must be set = 0 for read operations. The value in bits IAA0–IAA5 must be a valid transmit channel (01h to 20h for E1 mode; 01h to 18h for T1 mode).

Bit 6: Global Transmit-Idle Code (GTIC). Setting this bit causes all transmit channels to be set to the idle code written to the PCICR register. This bit must be set = 0 for read operations. The value in bits IAA0–IAA5 must be a valid transmit channel (01h to 20h for E1 mode; 01h to 18h for T1 mode).

GRIC	GTIC	FUNCTION
0	0	Updates a single transmit or receive channel
0	1	Updates all transmit channels
1	0	Updates all receive channels
1	1	Updates all transmit and receive channels

Bits 0 – 5: Channel Pointer Address Bits (IAA0 to IAA5). These bits select the channel to be programmed with the idle code defined in the TR.PCICR register. IAA0 is the LSB of the 5-bit channel code. Channel 1 is 01h.

Register Name: **TR.PCICR**
 Register Description: **Per-Channel Idle Code Register**
 Register Address: **7Fh**

Bit #	7	6	5	4	3	2	1	0
Name	C7	C6	C5	C4	C3	C2	C1	C0
Default	0	0	0	0	0	0	0	0

Bits 0 – 7: Per-Channel Idle-Code Bits (C0 to C7). This register defines the idle code to be programmed in the channel selected by the TR.IAAR register. C0 is the LSB of the idle code (this bit is transmitted last).

Register Name: **TR.TCICE1**
 Register Description: **Transmit-Channel Idle-Code Enable Register 1**
 Register Address: **80h**

Bit #	7	6	5	4	3	2	1	0
Name	CH8	CH7	CH6	CH5	CH4	CH3	CH2	CH1
Default	0	0	0	0	0	0	0	0

Bits 0 – 7: Transmit Channels 1 to 8 Code Insertion Control Bits (CH1 to CH8)

0 = do not insert data from the idle-code array into the transmit data stream

1 = insert data from the idle-code array into the transmit data stream

Register Name: **TR.TCICE2**
 Register Description: **Transmit-Channel Idle-Code Enable Register 2**
 Register Address: **81h**

Bit #	7	6	5	4	3	2	1	0
Name	CH16	CH15	CH14	CH13	CH12	CH11	CH10	CH9
Default	0	0	0	0	0	0	0	0

Bits 0 – 7: Transmit Channels 9 to 16 Code Insertion Control Bits (CH9 to CH16)

0 = do not insert data from the idle-code array into the transmit data stream

1 = insert data from the idle code-array into the transmit data stream

Register Name: **TR.TCICE3**
 Register Description: **Transmit-Channel Idle-Code Enable Register 3**
 Register Address: **82h**

Bit #	7	6	5	4	3	2	1	0
Name	CH24	CH23	CH22	CH21	CH20	CH19	CH18	CH17
Default	0	0	0	0	0	0	0	0

Bits 0 – 7: Transmit Channels 17 to 24 Code Insertion Control Bits (CH17 to CH24)

0 = do not insert data from the idle-code array into the transmit data stream

1 = insert data from the idle code-array into the transmit data stream

Register Name: **TR.TCICE4**
 Register Description: **Transmit-Channel Idle-Code Enable Register 4**
 Register Address: **83h**

Bit #	7	6	5	4	3	2	1	0
Name	CH32	CH31	CH30	CH29	CH28	CH27	CH26	CH25
Default	0	0	0	0	0	0	0	0

Bits 0 – 7: Transmit Channels 25 to 32 Code Insertion Control Bits (CH25 to CH32)

0 = do not insert data from the idle-code array into the transmit data stream

1 = insert data from the idle-code array into the transmit data stream

Register Name: **TR.RCICE1**
 Register Description: **Receive-Channel Idle-Code Enable Register 1**
 Register Address: **84h**

Bit #	7	6	5	4	3	2	1	0
Name	CH8	CH7	CH6	CH5	CH4	CH3	CH2	CH1
Default	0	0	0	0	0	0	0	0

Bits 0 – 7: Receive Channels 1 to 8 Code Insertion Control Bits (CH1 to CH8)

0 = do not insert data from the idle-code array into the receive data stream

1 = insert data from the idle-code array into the receive data stream

Register Name: **TR.RCICE2**
 Register Description: **Receive-Channel Idle-Code Enable Register 2**
 Register Address: **85h**

Bit #	7	6	5	4	3	2	1	0
Name	CH16	CH15	CH14	CH13	CH12	CH11	CH10	CH9
Default	0	0	0	0	0	0	0	0

Bits 0 – 7: Receive Channels 9 to 16 Code Insertion Control Bits (CH9 to CH16)

0 = do not insert data from the idle-code array into the receive data stream

1 = insert data from the idle-code array into the receive data stream

Register Name: **TR.RCICE3**
 Register Description: **Receive-Channel Idle-Code Enable Register 3**
 Register Address: **86h**

Bit #	7	6	5	4	3	2	1	0
Name	CH24	CH23	CH22	CH21	CH20	CH19	CH18	CH17
Default	0	0	0	0	0	0	0	0

Bits 0 – 7: Receive Channels 17 to 24 Code Insertion Control Bits (CH17 to CH24)

0 = do not insert data from the idle-code array into the receive data stream

1 = insert data from the idle-code array into the receive data stream

Register Name: **TR.RCICE4**
 Register Description: **Receive-Channel Idle-Code Enable Register 4**
 Register Address: **87h**

Bit #	7	6	5	4	3	2	1	0
Name	CH32	CH31	CH30	CH29	CH28	CH27	CH26	CH25
Default	0	0	0	0	0	0	0	0

Bits 0 – 7: Receive Channels 25 to 32 Code Insertion Control Bits (CH25 to CH32)

0 = do not insert data from the idle-code array into the receive data stream

1 = insert data from the idle-code array into the receive data stream

Register Name: **TR.RCBR1**
 Register Description: **Receive Channel Blocking Register 1**
 Register Address: **88h**

Bit #	7	6	5	4	3	2	1	0
Name	CH8	CH7	CH6	CH5	CH4	CH3	CH2	CH1
Default	0	0	0	0	0	0	0	0

Bits 0 – 7: Receive Channels 1 to 8 Channel Blocking Control Bits (CH1 to CH8)

0 = force the RCHBLK pin to remain low during this channel time

1 = force the RCHBLK pin high during this channel time

Register Name: **TR.RCBR2**
 Register Description: **Receive Channel Blocking Register 2**
 Register Address: **89h**

Bit #	7	6	5	4	3	2	1	0
Name	CH16	CH15	CH14	CH13	CH12	CH11	CH10	CH9
Default	0	0	0	0	0	0	0	0

Bits 0 – 7: Receive Channels 9 to 16 Channel Blocking Control Bits (CH9 to CH16)

0 = force the RCHBLK pin to remain low during this channel time

1 = force the RCHBLK pin high during this channel time

Register Name: **TR.RCBR3**
 Register Description: **Receive Channel Blocking Register 3**
 Register Address: **8Ah**

Bit #	7	6	5	4	3	2	1	0
Name	CH24	CH23	CH22	CH21	CH20	CH19	CH18	CH17
Default	0	0	0	0	0	0	0	0

Bits 0 – 7: Receive Channels 17 to 24 Channel Blocking Control Bits (CH17 to CH24)

0 = force the RCHBLK pin to remain low during this channel time

1 = force the RCHBLK pin high during this channel time

Register Name: **TR.RCBR4**
 Register Description: **Receive Channel Blocking Register 4**
 Register Address: **8Bh**

Bit #	7	6	5	4	3	2	1	0
Name	CH32	CH31	CH30	CH29	CH28	CH27	CH26	CH25
Default	0	0	0	0	0	0	0	0

Bits 0 – 7: Receive Channels 25 to 32 Channel Blocking Control Bits (CH25 to CH32)

0 = force the RCHBLK pin to remain low during this channel time

1 = force the RCHBLK pin high during this channel time

Register Name: **TR.TCBR1**
 Register Description: **Transmit Channel Blocking Register 1**
 Register Address: **8Ch**

Bit #	7	6	5	4	3	2	1	0
Name	CH8	CH7	CH6	CH5	CH4	CH3	CH2	CH1
Default	0	0	0	0	0	0	0	0

Bits 0 – 7: Transmit Channels 1 to 8 Channel Blocking Control Bits (CH1 to CH8)

0 = force the TCHBLK pin to remain low during this channel time

1 = force the TCHBLK pin high during this channel time

Register Name: **TR.TCBR2**
 Register Description: **Transmit Channel Blocking Register 2**
 Register Address: **8Dh**

Bit #	7	6	5	4	3	2	1	0
Name	CH16	CH15	CH14	CH13	CH12	CH11	CH10	CH9
Default	0	0	0	0	0	0	0	0

Bits 0 – 7: Transmit Channels 9 to 16 Channel Blocking Control Bits (CH9 to CH16)

0 = force the TCHBLK pin to remain low during this channel time

1 = force the TCHBLK pin high during this channel time

Register Name: **TR.TCBR3**
 Register Description: **Transmit Channel Blocking Register 3**
 Register Address: **8Eh**

Bit #	7	6	5	4	3	2	1	0
Name	CH24	CH23	CH22	CH21	CH20	CH19	CH18	CH17
Default	0	0	0	0	0	0	0	0

Bits 0 – 7: Transmit Channels 17 to 24 Channel Blocking Control Bits (CH17 to CH24)

0 = force the TCHBLK pin to remain low during this channel time

1 = force the TCHBLK pin high during this channel time

Register Name: **TR.TCBR4**
 Register Description: **Transmit Channel Blocking Register 4**
 Register Address: **8Fh**

Bit #	7	6	5	4	3	2	1	0
Name	CH32	CH31	CH30	CH29	CH28	CH27	CH26	CH25
Default	0	0	0	0	0	0	0	0

Bits 0 – 7: Transmit Channels 25 to 32 Channel Blocking Control Bits (CH25 to CH32)

0 = force the TCHBLK pin to remain low during this channel time

1 = force the TCHBLK pin high during this channel time

Register Name: **TR.H1TC, TR.H2TC**
 Register Description: **HDLC #1 Transmit Control**
HDLC #2 Transmit Control
 Register Address: **90h, A0h**

Bit #	7	6	5	4	3	2	1	0
Name	NOFS	TEOML	THR	THMS	TFS	TEOM	TZSD	TCRCD
Default	0	0	0	0	0	0	0	0

Bit 7: Number of Flags Select (NOFS)

- 0 = send one flag between consecutive messages
- 1 = send two flags between consecutive messages

Bit 6: Transmit End of Message and Loop (TEOML). To loop on a message, this bit should be set to a 1 just before the last data byte of an HDLC packet is written into the transmit FIFO. The message repeats until the user clears this bit or a new message is written to the transmit FIFO. If the host clears the bit, the looping message completes, then flags are transmitted until a new message is written to the FIFO. If the host terminates the loop by writing a new message to the FIFO, the loop terminates, one or two flags are transmitted, and the new message starts. If not disabled through TCRCD, the transmitter automatically appends a 2-byte CRC code to the end of all messages. This is useful for transmitting consecutive SS7 FISUs without host intervention.

Bit 5: Transmit HDLC Reset (THR). Resets the transmit HDLC controller and flushes the transmit FIFO. An abort followed by 7Eh or FFh flags/idle is transmitted until a new packet is initiated by writing new data into the FIFO. Must be cleared and set again for a subsequent reset.

- 0 = normal operation
- 1 = reset transmit HDLC controller and flush the transmit FIFO

Bit 4: Transmit HDLC Mapping Select (THMS)

- 0 = transmit HDLC assigned to channels
- 1 = transmit HDLC assigned to FDL (T1 mode), Sa bits (E1 mode)

Bit 3: Transmit Flag/Idle Select (TFS). This bit selects the intermessage fill character after the closing and before the opening flags (7Eh).

- 0 = 7Eh
- 1 = FFh

Bit 2: Transmit End of Message (TEOM). Should be set to a 1 just before the last data byte of an HDLC packet is written into the transmit FIFO at HxTF. If not disabled through TCRCD, the transmitter automatically appends a 2-byte CRC code to the end of the message.

Bit 1: Transmit Zero-Stuffer Defeat (TZSD). The zero-stuffer function automatically inserts a 0 in the message field (between the flags) after five consecutive 1s to prevent the emulation of a flag or abort sequence by the data pattern. The receiver automatically removes (destuffs) any 0 after five 1s in the message field.

- 0 = enable the zero stuffer (normal operation)
- 1 = disable the zero stuffer

Bit 0: Transmit CRC Defeat (TCRCD). A 2-byte CRC code is automatically appended to the outbound message. This bit can be used to disable the CRC function.

- 0 = enable CRC generation (normal operation)
- 1 = disable CRC generation

Register Name: **TR.H1FC, TR.H2FC**
 Register Description: **HDLC # 1 FIFO Control**
HDLC # 2 FIFO Control
 Register Address: **91h, A1h**

Bit #	7	6	5	4	3	2	1	0
Name	—	—	TFLWM2	TFLWM1	TFLWM0	RFHWM2	RFHWM1	RFHWM0
Default	0	0	0	0	0	0	0	0

Bits 3 – 5: Transmit FIFO Low-Watermark Select (TFLWM0 to TFLWM2)

TFLWM2	TFLWM1	TFLWM0	Transmit FIFO Watermark (bytes)
0	0	0	4
0	0	1	16
0	1	0	32
0	1	1	48
1	0	0	64
1	0	1	80
1	1	0	96
1	1	1	112

Bits 0 – 2: Receive FIFO High-Watermark Select (RFHWM0 to RFHWM2)

RFHWM2	RFHWM1	RFHWM0	Receive FIFO Watermark (bytes)
0	0	0	4
0	0	1	16
0	1	0	32
0	1	1	48
1	0	0	64
1	0	1	80
1	1	0	96
1	1	1	112

Register Name: **TR.H1RCS1, TR.H1RCS2, TR.H1RCS3, TR.H1RCS4
TR.H2RCS1, TR.H2RCS2, TR.H2RCS3, TR.H2RCS4**

Register Description: **HDLC # 1 Receive Channel Select
HDLC # 2 Receive Channel Select**

Register Address: **92h, 93h, 94h, 95h
A2h, A3h, A4h, A5h**

Bit #	7	6	5	4	3	2	1	0
Name	RHCS7	RHCS6	RHCS5	RHCS4	RHCS3	RHCS2	RHCS1	RHCS0
Default	0	0	0	0	0	0	0	0

Bit 7: Receive HDLC Channel Select Bit 7 (RHCS7). Select Channel 8, 16, 24, or 32.

Bit 6: Receive HDLC Channel Select Bit 6 (RHCS6). Select Channel 7, 15, 23, or 31.

Bit 5: Receive HDLC Channel Select Bit 5 (RHCS5). Select Channel 6, 14, 22, or 30.

Bit 4: Receive HDLC Channel Select Bit 4 (RHCS4). Select Channel 5, 13, 21, or 29.

Bit 3: Receive HDLC Channel Select Bit 3 (RHCS3). Select Channel 4, 12, 20, or 28.

Bit 2: Receive HDLC Channel Select Bit 2 (RHCS2). Select Channel 3, 11, 19, or 27.

Bit 1: Receive HDLC Channel Select Bit 1 (RHCS1). Select Channel 2, 10, 18, or 26.

Bit 0: Receive HDLC Channel Select Bit 0 (RHCS0). Select Channel 1, 9, 17, or 25.

Register Name: **TR.H1RTSBS, TR.H2RTSBS**
 Register Description: **HDLC # 1 Receive Time Slot Bits/Sa Bits Select**
HDLC # 2 Receive Time Slot Bits/Sa Bits Select
 Register Address: **96h, A6h**

Bit #	7	6	5	4	3	2	1	0
Name	RCB8SE	RCB7SE	RCB6SE	RCB5SE	RCB4SE	RCB3SE	RCB2SE	RCB1SE
Default	0	0	0	0	0	0	0	0

Bit 7: Receive Channel Bit 8 Suppress Enable (RCB8SE). MSB of the channel. Set to 1 to stop this bit from being used.

Bit 6: Receive Channel Bit 7 Suppress Enable (RCB7SE). Set to 1 to stop this bit from being used.

Bit 5: Receive Channel Bit 6 Suppress Enable (RCB6SE). Set to 1 to stop this bit from being used.

Bit 4: Receive Channel Bit 5 Suppress Enable/Sa4 Bit Enable (RCB5SE). Set to 1 to stop this bit from being used.

Bit 3: Receive Channel Bit 4 Suppress Enable/Sa5 Bit Enable (RCB4SE). Set to 1 to stop this bit from being used.

Bit 2: Receive Channel Bit 3 Suppress Enable/Sa6 Bit Enable (RCB3SE). Set to 1 to stop this bit from being used.

Bit 1: Receive Channel Bit 2 Suppress Enable/Sa7 Bit Enable (RCB2SE). Set to 1 to stop this bit from being used.

Bit 0: Receive Channel Bit 1 Suppress Enable/Sa8 Bit Enable (RCB1SE). LSB of the channel. Set to 1 to stop this bit from being used.

Register Name: **TR.H1TCS1, TR.H1TCS2, TR.H1TCS3, TR.H1TCS4
TR.H2TCS1, TR.H2TCS2, TR.H2TCS3, TR.H2TCS4**

Register Description: **HDLC # 1 Transmit Channel Select
HDLC # 2 Transmit Channel Select**

Register Address: **97h, 98h, 99h, 9Ah
A7h, A8h, A9h, AAh**

Bit #	7	6	5	4	3	2	1	0
Name	THCS7	THCS6	THCS5	THCS4	THCS3	THCS2	THCS1	THCS0
Default	0	0	0	0	0	0	0	0

Bit 7: Transmit HDLC Channel Select Bit 7 (THCS7). Select Channel 8, 16, 24, or 32.

Bit 6: Transmit HDLC Channel Select Bit 6 (THCS6). Select Channel 7, 15, 23, or 31.

Bit 5: Transmit HDLC Channel Select Bit 5 (THCS5). Select Channel 6, 14, 22, or 30.

Bit 4: Transmit HDLC Channel Select Bit 4 (THCS4). Select Channel 5, 13, 21, or 29.

Bit 3: Transmit HDLC Channel Select Bit 3 (THCS3). Select Channel 4, 12, 20, or 28.

Bit 2: Transmit HDLC Channel Select Bit 2 (THCS2). Select Channel 3, 11, 19, or 27.

Bit 1: Transmit HDLC Channel Select Bit 1 (THCS1). Select Channel 2, 10, 18, or 26.

Bit 0: Transmit HDLC Channel Select Bit 0 (THCS0). Select Channel 1, 9, 17, or 25.

Register Name: **TR.H1TTSBS, TR.H2TTSBS**
 Register Description: **HDLC # 1 Transmit Time Slot Bits/Sa Bits Select**
HDLC # 2 Transmit Time Slot Bits/Sa Bits Select
 Register Address: **9Bh, ABh**

Bit #	7	6	5	4	3	2	1	0
Name	TCB8SE	TCB7SE	TCB6SE	TCB5SE	TCB4SE	TCB3SE	TCB2SE	TCB1SE
Default	0	0	0	0	0	0	0	0

Bit 7: Transmit Channel Bit 8 Suppress Enable (TCB1SE). MSB of the channel. Set to 1 to stop this bit from being used.

Bit 6: Transmit Channel Bit 7 Suppress Enable (TCB1SE). Set to 1 to stop this bit from being used.

Bit 5: Transmit Channel Bit 6 Suppress Enable (TCB1SE). Set to 1 to stop this bit from being used.

Bit 4: Transmit Channel Bit 5 Suppress Enable/Sa4 Bit Enable (TCB1SE). Set to 1 to stop this bit from being used.

Bit 3: Transmit Channel Bit 4 Suppress Enable/Sa5 Bit Enable (TCB1SE). Set to 1 to stop this bit from being used.

Bit 2: Transmit Channel Bit 3 Suppress Enable/Sa6 Bit Enable (TCB1SE). Set to 1 to stop this bit from being used.

Bit 1: Transmit Channel Bit 2 Suppress Enable/Sa7 Bit Enable (TCB1SE). Set to 1 to stop this bit from being used.

Bit 0: Transmit Channel Bit 1 Suppress Enable/Sa8 Bit Enable (TCB1SE). LSB of the channel. Set to 1 to stop this bit from being used.

Register Name: **TR.H1RPBA, TR.H2RPBA**
 Register Description: **HDLC # 1 Receive Packet Bytes Available**
HDLC # 2 Receive Packet Bytes Available
 Register Address: **9Ch, ACh**

Bit #	7	6	5	4	3	2	1	0
Name	MS	RPBA6	RPBA5	RPBA4	RPBA3	RPBA2	RPBA1	RPBA0
Default	0	0	0	0	0	0	0	0

Bit 7: Message Status (MS)

0 = bytes indicated by RPBA0 through RPBA6 are the end of a message. Host must check the INFO5 or INFO6 register for details.

1 = bytes indicated by RPBA0 through RPBA6 are the beginning or continuation of a message. The host does not need to check the INFO5 or INFO6 register.

Bits 0 – 6: Receive FIFO Packet Bytes Available Count (RPBA0 to RPBA6). RPBA0 is the LSB.

Register Name: **TR.H1TF, TR.H2TF**
 Register Description: **HDLC # 1 Transmit FIFO**
HDLC # 2 Transmit FIFO
 Register Address: **9Dh, ADh**

Bit #	7	6	5	4	3	2	1	0
Name	THD7	THD6	THD5	THD4	THD3	THD2	THD1	THD0
Default	0	0	0	0	0	0	0	0

Bit 7: Transmit HDLC Data Bit 7 (THD7). MSB of an HDLC packet data byte.

Bit 6: Transmit HDLC Data Bit 6 (THD6)

Bit 5: Transmit HDLC Data Bit 5 (THD5)

Bit 4: Transmit HDLC Data Bit 4 (THD4)

Bit 3: Transmit HDLC Data Bit 3 (THD3)

Bit 2: Transmit HDLC Data Bit 2 (THD2)

Bit 1: Transmit HDLC Data Bit 1 (THD1)

Bit 0: Transmit HDLC Data Bit 0 (THD0). LSB of an HDLC packet data byte.

Register Name: **TR.H1RF, TR.H2RF**
 Register Description: **HDLC # 1 Receive FIFO**
HDLC # 2 Receive FIFO
 Register Address: **9Eh, AEh**

Bit #	7	6	5	4	3	2	1	0
Name	RHD7	RHD6	RHD5	RHD4	RHD3	RHD2	RHD1	RHD0
Default	0	0	0	0	0	0	0	0

Bit 7: Receive HDLC Data Bit 7 (RHD7). MSB of an HDLC packet data byte.

Bit 6: Receive HDLC Data Bit 6 (RHD6)

Bit 5: Receive HDLC Data Bit 5 (RHD5)

Bit 4: Receive HDLC Data Bit 4 (RHD4)

Bit 3: Receive HDLC Data Bit 3 (RHD3)

Bit 2: Receive HDLC Data Bit 2 (RHD2)

Bit 1: Receive HDLC Data Bit 1 (RHD1)

Bit 0: Receive HDLC Data Bit 0 (RHD0). LSB of an HDLC packet data byte.

Register Name: **TR.H1TFBA, TR.H2TFBA**
 Register Description: **HDLC # 1 Transmit FIFO Buffer Available**
HDLC # 2 Transmit FIFO Buffer Available
 Register Address: **9Fh, Afh**

Bit #	7	6	5	4	3	2	1	0
Name	TFBA7	TFBA6	TFBA5	TFBA4	TFBA3	TFBA2	TFBA1	TFBA0
Default	0	0	0	0	0	0	0	0

Bits 0 – 7: Transmit FIFO Bytes Available (TFBA0 to TFBA7). TFBA0 is the LSB.

Register Name: **TR.IBCC**
 Register Description: **In-Band Code Control Register**
 Register Address: **B6h**

Bit #	7	6	5	4	3	2	1	0
Name	TC1	TC0	RUP2	RUP1	RUP0	RDN2	RDN1	RDN0
Default	0	0	0	0	0	0	0	0

Bits 6 – 7: Transmit Code Length Definition Bits (TC0 to TC1)

TC1	TC0	Length Selected (bits)
0	0	5
0	1	6/3
1	0	7
1	1	16/8/4/2/1

Bits 3 – 5: Receive Up-Code Length Definition Bits (RUP0 to RUP2)

RUP2	RUP1	RUP0	Length Selected (bits)
0	0	0	1
0	0	1	2
0	1	0	3
0	1	1	4
1	0	0	5
1	0	1	6
1	1	0	7
1	1	1	8/16

Bits 0 – 2: Receive Down-Code Length Definition Bits (RDN0 to RDN2)

RDN2	RDN1	RDN0	Length Selected (bits)
0	0	0	1
0	0	1	2
0	1	0	3
0	1	1	4
1	0	0	5
1	0	1	6
1	1	0	7
1	1	1	8/16

Register Name: **TR.TCD1**
 Register Description: **Transmit Code-Definition Register 1**
 Register Address: **B7h**

Bit #	7	6	5	4	3	2	1	0
Name	C7	C6	C5	C4	C3	C2	C1	C0
Default	0	0	0	0	0	0	0	0

Bit 7: Transmit Code-Definition Bit 7 (C7). First bit of the repeating pattern.

Bits 3 – 6: Transmit Code-Definition Bits 3–6 (C3–C6)

Bit 2: Transmit Code-Definition Bit 2 (C2). A don't care if a 5-bit length is selected.

Bit 1: Transmit Code-Definition Bit 1 (C1). A don't care if a 5-bit or 6-bit length is selected.

Bit 0: Transmit Code-Definition Bit 0 (C0). A don't care if a 5-, 6-, or 7-bit length is selected.

Register Name: **TR.TCD2**
 Register Description: **Transmit Code Definition Register 2**
 Register Address: **B8h**

Bit #	7	6	5	4	3	2	1	0
Name	C7	C6	C5	C4	C3	C2	C1	C0
Default	0	0	0	0	0	0	0	0

Least significant byte of 16 bit code.

Bits 0 – 7: Transmit Code-Definition Bits 0–7 (C0–C7). A don't care if a 5-, 6-, or 7-bit length is selected.

Register Name: **TR.RUPCD1**
 Register Description: **Receive Up-Code Definition Register 1**
 Register Address: **B9h**

Bit #	7	6	5	4	3	2	1	0
Name	C7	C6	C5	C4	C3	C2	C1	C0
Default	0	0	0	0	0	0	0	0

Note: Writing this register resets the detector's integration period.

Bit 7: Receive Up-Code Definition Bit 7 (C7). First bit of the repeating pattern.

Bit 6: Receive Up-Code Definition Bit 6 (C6). A don't care if a 1-bit length is selected.

Bit 5: Receive Up-Code Definition Bit 5 (C5). A don't care if a 1-bit or 2-bit length is selected.

Bit 4: Receive Up-Code Definition Bit 4 (C4). A don't care if a 1-bit to 3-bit length is selected.

Bit 3: Receive Up-Code Definition Bit 3 (C3). A don't care if a 1-bit to 4-bit length is selected.

Bit 2: Receive Up-Code Definition Bit 2 (C2). A don't care if a 1-bit to 5-bit length is selected.

Bit 1: Receive Up-Code Definition Bit 1 (C1). A don't care if a 1-bit to 6-bit length is selected.

Bit 0: Receive Up-Code Definition Bit 0 (C0). A don't care if a 1-bit to 7-bit length is selected.

Register Name: **TR.RUPCD2**
 Register Description: **Receive Up-Code Definition Register 2**
 Register Address: **BAh**

Bit #	7	6	5	4	3	2	1	0
Name	C7	C6	C5	C4	C3	C2	C1	C0
Default	0	0	0	0	0	0	0	0

Bits 0 – 7: Receive Up-Code Definition Bits 0–7 (C0–C7). A don't care if a 1-bit to 7-bit length is selected.

Register Name: **TR.RDNCD1**
 Register Description: **Receive Down-Code Definition Register 1**
 Register Address: **BBh**

Bit #	7	6	5	4	3	2	1	0
Name	C7	C6	C5	C4	C3	C2	C1	C0
Default	0	0	0	0	0	0	0	0

Note: Writing this register resets the detector's integration period.

Bit 7: Receive Down-Code Definition Bit 7 (C7). First bit of the repeating pattern.

Bit 6: Receive Down-Code Definition Bit 6 (C6). A don't care if a 1-bit length is selected.

Bit 5: Receive Down-Code Definition Bit 5 (C5). A don't care if a 1-bit or 2-bit length is selected.

Bit 4: Receive Down-Code Definition Bit 4 (C4). A don't care if a 1-bit to 3-bit length is selected.

Bit 3: Receive Down-Code Definition Bit 3 (C3). A don't care if a 1-bit to 4-bit length is selected.

Bit 2: Receive Down-Code Definition Bit 2 (C2). A don't care if a 1-bit to 5-bit length is selected.

Bit 1: Receive Down-Code Definition Bit 1 (C1). A don't care if a 1-bit to 6-bit length is selected.

Bit 0: Receive Down-Code Definition Bit 0 (C0). A don't care if a 1-bit to 7-bit length is selected.

Register Name: **TR.RDNCD2**
 Register Description: **Receive Down-Code Definition Register 2**
 Register Address: **BCh**

Bit #	7	6	5	4	3	2	1	0
Name	C7	C6	C5	C4	C3	C2	C1	C0
Default	0	0	0	0	0	0	0	0

Bits 0 – 7: Receive Down-Code Definition Bits 0–7 (C0–C7). A don't care if a 1-bit to 7-bit length is selected.

Register Name: **TR.RSCC**
 Register Description: **In-Band Receive Spare Control Register**
 Register Address: **BDh**

Bit #	7	6	5	4	3	2	1	0
Name	—	—	—	—	—	RSC2	RSC1	RSC0
Default	0	0	0	0	0	0	0	0

Bits 3 – 7: Unused, must be set to 0 for proper operation

Bits 0 – 2: Receive Spare Code Length Definition Bits (RSC0 to RSC2)

RSC2	RSC1	RSC0	Length Selected (bits)
0	0	0	1
0	0	1	2
0	1	0	3
0	1	1	4
1	0	0	5
1	0	1	6
1	1	0	7
1	1	1	8/16

Register Name: **TR.RSCD1**
 Register Description: **Receive Spare-Code Definition Register 1**
 Register Address: **BEh**

Bit #	7	6	5	4	3	2	1	0
Name	C7	C6	C5	C4	C3	C2	C1	C0
Default	0	0	0	0	0	0	0	0

Note: Writing this register resets the detector's integration period.

Bit 7: Receive Spare-Code Definition Bit 7 (C7). First bit of the repeating pattern.

Bit 6: Receive Spare-Code Definition Bit 6 (C6). A don't care if a 1-bit length is selected.

Bit 5: Receive Spare-Code Definition Bit 5 (C5). A don't care if a 1-bit or 2-bit length is selected.

Bit 4: Receive Spare-Code Definition Bit 4 (C4). A don't care if a 1-bit to 3-bit length is selected.

Bit 3: Receive Spare-Code Definition Bit 3 (C3). A don't care if a 1-bit to 4-bit length is selected.

Bit 2: Receive Spare-Code Definition Bit 2 (C2). A don't care if a 1-bit to 5-bit length is selected.

Bit 1: Receive Spare-Code Definition Bit 1 (C1). A don't care if a 1-bit to 6-bit length is selected.

Bit 0: Receive Spare-Code Definition Bit 0 (C0). A don't care if a 1-bit to 7-bit length is selected.

Register Name: **TR.RSCD2**
 Register Description: **Receive Spare Code Definition Register 2**
 Register Address: **BFh**

Bit #	7	6	5	4	3	2	1	0
Name	C7	C6	C5	C4	C3	C2	C1	C0
Default	0	0	0	0	0	0	0	0

Bits 0 – 7: Receive Spare-Code Definition Bits 0–7 (C0–C7). A don't care if a 1-bit to 7-bit length is selected.

Register Name: **TR.RFDL (TR.BOCC.4 = 1)**
 Register Description: **Receive FDL Register**
 Register Address: **C0h**

Bit #	7	6	5	4	3	2	1	0
Name	—	—	RBOC5	RBOC4	RBOC3	RBOC2	RBOC1	RBOC0
Default	0	0	0	0	0	0	0	0

RFDL register bit definitions when TR.BOCC.4 = 1:

Bit 5: BOC Bit 5 (RBOC5)

Bit 4: BOC Bit 4 (RBOC4)

Bit 3: BOC Bit 3 (RBOC3)

Bit 2: BOC Bit 2 (RBOC2)

Bit 1: BOC Bit 1 (RBOC1)

Bit 0: BOC Bit 0 (RBOC0)

Register Name: **TR.RFDL (TR.BOCC.4 = 0)**
 Register Description: **Receive FDL Register**
 Register Address: **C0h**

Bit #	7	6	5	4	3	2	1	0
Name	RFDL7	RFDL6	RFDL5	RFDL4	RFDL3	RFDL2	RFDL1	RFDL0
Default	0	0	0	0	0	0	0	0

The receive FDL register (TR.RFDL) reports the incoming FDL or the incoming Fs bits. The LSB is received first.

Bit 7: Receive FDL Bit 7 (RFDL7). MSB of the received FDL code.

Bit 6: Receive FDL Bit 6 (RFDL6)

Bit 5: Receive FDL Bit 5 (RFDL5)

Bit 4: Receive FDL Bit 4 (RFDL4)

Bit 3: Receive FDL Bit 3 (RFDL3)

Bit 2: Receive FDL Bit 2 (RFDL2)

Bit 1: Receive FDL Bit 1 (RFDL1)

Bit 0: Receive FDL Bit 0 (RFDL0). LSB of the received FDL code.

Register Name: **TR.TFDL**
 Register Description: **Transmit FDL Register**
 Register Address: **C1h**

Bit #	7	6	5	4	3	2	1	0
Name	TFDL7	TFDL6	TFDL5	TFDL4	TFDL3	TFDL2	TFDL1	TFDL0
Default	0	0	0	0	0	0	0	0

Note: Also used to insert Fs framing pattern in D4 framing mode.

The transmit FDL register (TR.TFDL) contains the FDL information that is to be inserted on a byte basis into the outgoing T1 data stream. The LSB is transmitted first.

Bit 7: Transmit FDL Bit 7 (TFDL7). MSB of the transmit FDL code.

Bit 6: Transmit FDL Bit 6 (TFDL6)

Bit 5: Transmit FDL Bit 5 (TFDL5)

Bit 4: Transmit FDL Bit 4 (TFDL4)

Bit 3: Transmit FDL Bit 3 (TFDL3)

Bit 2: Transmit FDL Bit 2 (TFDL2)

Bit 1: Transmit FDL Bit 1 (TFDL1)

Bit 0: Transmit FDL Bit 0 (TFDL0). LSB of the transmit FDL code.

Register Name: **TR.RFDLM1, TR.RFDLM2**
 Register Description: **Receive FDL Match Register 1**
Receive FDL Match Register 2
 Register Address: **C2h, C3h**

Bit #	7	6	5	4	3	2	1	0
Name	RFDLM7	RFDLM6	RFDLM5	RFDLM4	RFDLM3	RFDLM2	RFDLM1	RFDLM0
Default	0	0	0	0	0	0	0	0

Bit 7: Receive FDL Match Bit 7 (RFDLM7). MSB of the FDL match code.

Bit 6: Receive FDL Match Bit 6 (RFDLM6)

Bit 5: Receive FDL Match Bit 5 (RFDLM5)

Bit 4: Receive FDL Match Bit 4 (RFDLM4)

Bit 3: Receive FDL Match Bit 3 (RFDLM3)

Bit 2: Receive FDL Match Bit 2 (RFDLM2)

Bit 1: Receive FDL Match Bit 1 (RFDLM1)

Bit 0: Receive FDL Match Bit 0 (RFDLM0). LSB of the FDL match code.

Register Name: **TR.RAF**
 Register Description: **Receive Align Frame Register**
 Register Address: **C6h**

Bit #	7	6	5	4	3	2	1	0
Name	Si	0	0	1	1	0	1	1
Default	0	0	0	0	0	0	0	0

Bit 7: International Bit (Si)

Bit 6: Frame Alignment Signal Bit (0)

Bit 5: Frame Alignment Signal Bit (0)

Bit 4: Frame Alignment Signal Bit (1)

Bit 3: Frame Alignment Signal Bit (1)

Bit 2: Frame Alignment Signal Bit (0)

Bit 1: Frame Alignment Signal Bit (1)

Bit 0: Frame Alignment Signal Bit (1)

Register Name: **TR.RNAF**
 Register Description: **Receive Nonalign Frame Register**
 Register Address: **C7h**

Bit #	7	6	5	4	3	2	1	0
Name	Si	1	A	Sa4	Sa5	Sa6	Sa7	Sa8
Default	0	0	0	0	0	0	0	0

Bit 7: International Bit (Si)

Bit 6: Frame Nonalignment Signal Bit (1)

Bit 5: Remote Alarm (A)

Bit 4: Additional Bit 4 (Sa4)

Bit 3: Additional Bit 5 (Sa5)

Bit 2: Additional Bit 6 (Sa6)

Bit 1: Additional Bit 7 (Sa7)

Bit 0: Additional Bit 8 (Sa8)

Register Name: **TR.RSiAF**
 Register Description: **Received Si Bits of the Align Frame**
 Register Address: **C8h**

Bit #	7	6	5	4	3	2	1	0
Name	SiF0	SiF2	SiF4	SiF6	SiF8	SiF10	SiF12	SiF14
Default	0	0	0	0	0	0	0	0

Bit 7: Si Bit of Frame 0 (SiF0)

Bit 6: Si Bit of Frame 2 (SiF2)

Bit 5: Si Bit of Frame 4 (SiF4)

Bit 4: Si Bit of Frame 6 (SiF6)

Bit 3: Si Bit of Frame 8 (SiF8)

Bit 2: Si Bit of Frame 10 (SiF10)

Bit 1: Si Bit of Frame 12 (SiF12)

Bit 0: Si Bit of Frame 14 (SiF14)

Register Name: **TR.RSiNAF**
 Register Description: **Received Si Bits of the Nonalign Frame**
 Register Address: **C9h**

Bit #	7	6	5	4	3	2	1	0
Name	SiF1	SiF3	SiF5	SiF7	SiF9	SiF11	SiF13	SiF15
Default	0	0	0	0	0	0	0	0

Bit 7: Si Bit of Frame 1 (SiF1)

Bit 6: Si Bit of Frame 3 (SiF3)

Bit 5: Si Bit of Frame 5 (SiF5)

Bit 4: Si Bit of Frame 7 (SiF7)

Bit 3: Si Bit of Frame 9 (SiF9)

Bit 2: Si Bit of Frame 11 (SiF11)

Bit 1: Si Bit of Frame 13 (SiF13)

Bit 0: Si Bit of Frame 15 (SiF15)

Register Name: **TR.RRA**
 Register Description: **Received Remote Alarm**
 Register Address: **Cah**

Bit #	7	6	5	4	3	2	1	0
Name	RRAF1	RRAF3	RRAF5	RRAF7	RRAF9	RRAF11	RRAF13	RRAF15
Default	0	0	0	0	0	0	0	0

Bit 7: Remote Alarm Bit of Frame 1 (RRAF1)

Bit 6: Remote Alarm Bit of Frame 3 (RRAF3)

Bit 5: Remote Alarm Bit of Frame 5 (RRAF5)

Bit 4: Remote Alarm Bit of Frame 7 (RRAF7)

Bit 3: Remote Alarm Bit of Frame 9 (RRAF9)

Bit 2: Remote Alarm Bit of Frame 11 (RRAF11)

Bit 1: Remote Alarm Bit of Frame 13 (RRAF13)

Bit 0: Remote Alarm Bit of Frame 15 (RRAF15)

Register Name: **TR.RSa4**
 Register Description: **Received Sa4 Bits**
 Register Address: **CBh**

Bit #	7	6	5	4	3	2	1	0
Name	RSa4F1	RSa4F3	RSa4F5	RSa4F7	RSa4F9	RSa4F11	RSa4F13	RSa4F15
Default	0	0	0	0	0	0	0	0

Bit 7: Sa4 Bit of Frame 1 (RSa4F1)

Bit 6: Sa4 Bit of Frame 3 (RSa4F3)

Bit 5: Sa4 Bit of Frame 5 (RSa4F5)

Bit 4: Sa4 Bit of Frame 7 (RSa4F7)

Bit 3: Sa4 Bit of Frame 9 (RSa4F9)

Bit 2: Sa4 Bit of Frame 11 (RSa4F11)

Bit 1: Sa4 Bit of Frame 13 (RSa4F13)

Bit 0: Sa4 Bit of Frame 15 (RSa4F15)

Register Name: **TR.RSa5**
 Register Description: **Received Sa5 Bits**
 Register Address: **CCh**

Bit #	7	6	5	4	3	2	1	0
Name	RSa5F1	RSa5F3	RSa5F5	RSa5F7	RSa5F9	RSa5F11	RSa5F13	RSa5F15
Default	0	0	0	0	0	0	0	0

Bit 7: Sa5 Bit of Frame 1 (RSa5F1)

Bit 6: Sa5 Bit of Frame 3 (RSa5F3)

Bit 5: Sa5 Bit of Frame 5 (RSa5F5)

Bit 4: Sa5 Bit of Frame 7 (RSa5F7)

Bit 3: Sa5 Bit of Frame 9 (RSa5F9)

Bit 2: Sa5 Bit of Frame 11 (RSa5F11)

Bit 1: Sa5 Bit of Frame 13 (RSa5F13)

Bit 0: Sa5 Bit of Frame 15 (RSa5F15)

Register Name: **TR.RSa6**
 Register Description: **Received Sa6 Bits**
 Register Address: **CDh**

Bit #	7	6	5	4	3	2	1	0
Name	RSa6F1	RSa6F3	RSa6F5	RSa6F7	RSa6F9	RSa6F11	RSa6F13	RSa6F15
Default	0	0	0	0	0	0	0	0

Bit 7: Sa6 Bit of Frame 3(RSa6F3)

Bit 6: Sa6 Bit of Frame 4 (RSa6F4)

Bit 5: Sa6 Bit of Frame 5 (RSa6F5)

Bit 4: Sa6 Bit of Frame 7 (RSa6F7)

Bit 3: Sa6 Bit of Frame 9 (RSa6F9)

Bit 2: Sa6 Bit of Frame 11 (RSa6F11)

Bit 1: Sa6 Bit of Frame 13 (RSa6F13)

Bit 0: Sa6 Bit of Frame 15 (RSa6F15)

Register Name: **TR.RSa7**
 Register Description: **Received Sa7 Bits**
 Register Address: **CEh**

Bit #	7	6	5	4	3	2	1	0
Name	RSa7F1	Rsa7F3	RSa7F5	RSa7F7	RSa7F9	RSa7F11	RSa7F13	RSa7F15
Default	0	0	0	0	0	0	0	0

Bit 7: Sa7 Bit of Frame 1 (RSa4F1)

Bit 6: Sa7 Bit of Frame 3 (RSa7F3)

Bit 5: Sa7 Bit of Frame 5 (RSa7F5)

Bit 4: Sa7 Bit of Frame 7 (RSa7F7)

Bit 3: Sa7 Bit of Frame 9 (RSa7F9)

Bit 2: Sa7 Bit of Frame 11 (RSa7F11)

Bit 1: Sa7 Bit of Frame 13 (RSa7F13)

Bit 0: Sa7 Bit of Frame 15 (RSa7F15)

Register Name: **TR.RSa8**
 Register Description: **Received Sa8 Bits**
 Register Address: **CFh**

Bit #	7	6	5	4	3	2	1	0
Name	RSa8F1	RSa8F3	RSa8F5	RSa8F7	RSa8F9	RSa8F11	RSa8F13	RSa8F15
Default	0	0	0	0	0	0	0	0

Bit 7: Sa8 Bit of Frame 1 (RSa8F1)

Bit 6: Sa8 Bit of Frame 3 (RSa8F3)

Bit 5: Sa8 Bit of Frame 5 (RSa8F5)

Bit 4: Sa8 Bit of Frame 7 (RSa8F7)

Bit 3: Sa8 Bit of Frame 9 (RSa8F9)

Bit 2: Sa8 Bit of Frame 11 (RSa8F11)

Bit 1: Sa8 Bit of Frame 13 (RSa8F13)

Bit 0: Sa8 Bit of Frame 15 (RSa8F15)

Register Name: **TR.TAF**
 Register Description: **Transmit Align Frame Register**
 Register Address: **D0h**

Bit #	7	6	5	4	3	2	1	0
Name	Si	0	0	1	1	0	1	1
Default	0	0	0	1	1	0	1	1

Bit 7: International Bit (Si)

Bit 6: Frame Alignment Signal Bit (0)

Bit 5: Frame Alignment Signal Bit (0)

Bit 4: Frame Alignment Signal Bit (1)

Bit 3: Frame Alignment Signal Bit (1)

Bit 2: Frame Alignment Signal Bit (0)

Bit 1: Frame Alignment Signal Bit (1)

Bit 0: Frame Alignment Signal Bit (1)

Register Name: **TR.TNAF**
 Register Description: **Transmit Nonalign Frame Register**
 Register Address: **D1h**

Bit #	7	6	5	4	3	2	1	0
Name	Si	1	A	Sa4	Sa5	Sa6	Sa7	Sa8
Default	0	1	0	0	0	0	0	0

Bit 7: International Bit (Si)

Bit 6: Frame Nonalignment Signal Bit (1)

Bit 5: Remote Alarm [used to transmit the alarm (A)]

Bit 4: Additional Bit 4 (Sa4)

Bit 3: Additional Bit 5 (Sa5)

Bit 2: Additional Bit 6 (Sa6)

Bit 1: Additional Bit 7 (Sa7)

Bit 0: Additional Bit 8 (Sa8)

Register Name: **TR.TSiAF**
 Register Description: **Transmit Si Bits of the Align Frame**
 Register Address: **D2h**

Bit #	7	6	5	4	3	2	1	0
Name	TSiF0	TSiF2	TSiF4	TSiF6	TSiF8	TSiF10	TSiF12	TSiF14
Default	0	0	0	0	0	0	0	0

Bit 7: Si Bit of Frame 0 (TSiF0)

Bit 6: Si Bit of Frame 2 (TSiF2)

Bit 5: Si Bit of Frame 4 (TSiF4)

Bit 4: Si Bit of Frame 6 (TSiF6)

Bit 3: Si Bit of Frame 8 (TSiF8)

Bit 2: Si Bit of Frame 10 (TSiF10)

Bit 1: Si Bit of Frame 12 (TSiF12)

Bit 0: Si Bit of Frame 14 (TSiF14)

Register Name: **TR.TSiNAF**
 Register Description: **Transmit Si Bits of the Nonalign Frame**
 Register Address: **D3h**

Bit #	7	6	5	4	3	2	1	0
Name	TSiF1	TSiF3	TSiF5	TSiF7	TSiF9	TSiF11	TSiF13	TSiF15
Default	0	0	0	0	0	0	0	0

Bit 7: Si Bit of Frame 1 (TSiF1)

Bit 6: Si Bit of Frame 3 (TSiF3)

Bit 5: Si Bit of Frame 5 (TSiF5)

Bit 4: Si Bit of Frame 7 (TSiF7)

Bit 3: Si Bit of Frame 9 (TSiF9)

Bit 2: Si Bit of Frame 11 (TSiF11)

Bit 1: Si Bit of Frame 13 (TSiF13)

Bit 0: Si Bit of Frame 15 (TSiF15)

Register Name: **TR.TRA**
 Register Description: **Transmit Remote Alarm**
 Register Address: **D4h**

Bit #	7	6	5	4	3	2	1	0
Name	TRAF1	TRAF3	TRAF5	TRAF7	TRAF9	TRAF11	TRAF13	TRAF15
Default	0	0	0	0	0	0	0	0

Bit 7: Remote Alarm Bit of Frame 1 (TRAF1)

Bit 6: Remote Alarm Bit of Frame 3 (TRAF3)

Bit 5: Remote Alarm Bit of Frame 5 (TRAF5)

Bit 4: Remote Alarm Bit of Frame 7 (TRAF7)

Bit 3: Remote Alarm Bit of Frame 9 (TRAF9)

Bit 2: Remote Alarm Bit of Frame 11 (TRAF11)

Bit 1: Remote Alarm Bit of Frame 13 (TRAF13)

Bit 0: Remote Alarm Bit of Frame 15 (TRAF15)

Register Name: **TR.TSa4**
 Register Description: **Transmit Sa4 Bits**
 Register Address: **D5h**

Bit #	7	6	5	4	3	2	1	0
Name	TSa4F1	TSa4F3	TSa4F5	TSa4F7	TSa4F9	TSa4F11	TSa4F13	TSa4F15
Default	0	0	0	0	0	0	0	0

Bit 7: Sa4 Bit of Frame 1 (TSa4F1)

Bit 6: Sa4 Bit of Frame 3 (TSa4F3)

Bit 5: Sa4 Bit of Frame 5 (TSa4F5)

Bit 4: Sa4 Bit of Frame 7 (TSa4F7)

Bit 3: Sa4 Bit of Frame 9 (TSa4F9)

Bit 2: Sa4 Bit of Frame 11 (TSa4F11)

Bit 1: Sa4 Bit of Frame 13 (TSa4F13)

Bit 0: Sa4 Bit of Frame 15 (TSa4F15)

Register Name: **TR.TSa5**
 Register Description: **Transmitted Sa5 Bits**
 Register Address: **D6h**

Bit #	7	6	5	4	3	2	1	0
Name	TSa5F1	TSa5F3	TSa5F5	TSa5F7	TSa5F9	TSa5F11	TSa5F13	TSa5F15
Default	0	0	0	0	0	0	0	0

Bit 7: Sa5 Bit of Frame 1 (TSa5F1)

Bit 6: Sa5 Bit of Frame 3 (TSa5F3)

Bit 5: Sa5 Bit of Frame 5 (TSa5F5)

Bit 4: Sa5 Bit of Frame 7 (TSa5F7)

Bit 3: Sa5 Bit of Frame 9 (TSa5F9)

Bit 2: Sa5 Bit of Frame 11 (TSa5F11)

Bit 1: Sa5 Bit of Frame 13 (TSa5F13)

Bit 0: Sa5 Bit of Frame 15 (TSa5F15)

Register Name: **TR.TSa6**
 Register Description: **Transmit Sa6 Bits**
 Register Address: **D7h**

Bit #	7	6	5	4	3	2	1	0
Name	TSa6F1	TSa6F3	TSa6F5	TSa6F7	TSa6F9	TSa6F11	TSa6F13	TSa6F15
Default	0	0	0	0	0	0	0	0

Bit 7: Sa6 Bit of Frame 1 (TSa6F1)

Bit 6: Sa6 Bit of Frame 3 (TSa6F3)

Bit 5: Sa6 Bit of Frame 5 (TSa6F5)

Bit 4: Sa6 Bit of Frame 7 (TSa6F7)

Bit 3: Sa6 Bit of Frame 9 (TSa6F9)

Bit 2: Sa6 Bit of Frame 11 (TSa6F11)

Bit 1: Sa6 Bit of Frame 13 (TSa6F13)

Bit 0: Sa6 Bit of Frame 15 (TSa6F15)

Register Name: **TR.TSa7**
 Register Description: **Transmit Sa7 Bits**
 Register Address: **D8h**

Bit #	7	6	5	4	3	2	1	0
Name	TSa7F1	TSa7F3	TSa7F5	TSa7F7	TSa7F9	TSa7F11	TSa7F13	TSa7F15
Default	0	0	0	0	0	0	0	0

Bit 7: Sa7 Bit of Frame 1 (TSa4F1)

Bit 6: Sa7 Bit of Frame 3 (TSa7F3)

Bit 5: Sa7 Bit of Frame 5 (TSa7F5)

Bit 4: Sa7 Bit of Frame 7 (TSa7F7)

Bit 3: Sa7 Bit of Frame 9 (TSa7F9)

Bit 2: Sa7 Bit of Frame 11 (TSa7F11)

Bit 1: Sa7 Bit of Frame 13 (TSa7F13)

Bit 0: Sa7 Bit of Frame 15 (TSa7F15)

Register Name: **TR.TSa8**
 Register Description: **Transmit Sa8 Bits**
 Register Address: **D9h**

Bit #	7	6	5	4	3	2	1	0
Name	TSa8F1	TSa8F3	TSa8F5	TSa8F7	TSa8F9	TSa8F11	TSa8F13	TSa8F15
Default	0	0	0	0	0	0	0	0

Bit 7: Sa8 Bit of Frame 1 (TSa8F1)

Bit 6: Sa8 Bit of Frame 3 (TSa8F3)

Bit 5: Sa8 Bit of Frame 5 (TSa8F5)

Bit 4: Sa8 Bit of Frame 7 (TSa8F7)

Bit 3: Sa8 Bit of Frame 9 (TSa8F9)

Bit 2: Sa8 Bit of Frame 11 (TSa8F11)

Bit 1: Sa8 Bit of Frame 13 (TSa8F13)

Bit 0: Sa8 Bit of Frame 15 (TSa8F15)

Register Name: **TR.TSACR**
 Register Description: **Transmit Sa Bit Control Register**
 Register Address: **DAh**

Bit #	7	6	5	4	3	2	1	0
Name	SiAF	SiNAF	RA	Sa4	Sa5	Sa6	Sa7	Sa8
Default	0	0	0	0	0	0	0	0

Bit 7: International Bit in Align Frame Insertion Control Bit (SiAF)

0 = do not insert data from the TR.TSiAF register into the transmit data stream

1 = insert data from the TR.TSiAF register into the transmit data stream

Bit 6: International Bit in Nonalign Frame Insertion Control Bit (SiNAF)

0 = do not insert data from the TR.TSiNAF register into the transmit data stream

1 = insert data from the TR.TSiNAF register into the transmit data stream

Bit 5: Remote Alarm Insertion Control Bit (RA)

0 = do not insert data from the TR.TRA register into the transmit data stream

1 = insert data from the TR.TRA register into the transmit data stream

Bit 4: Additional Bit 4 Insertion Control Bit (Sa4)

0 = do not insert data from the TR.TSa4 register into the transmit data stream

1 = insert data from the TR.TSa4 register into the transmit data stream

Bit 3: Additional Bit 5 Insertion Control Bit (Sa5)

0 = do not insert data from the TR.TSa5 register into the transmit data stream

1 = insert data from the TR.TSa5 register into the transmit data stream

Bit 2: Additional Bit 6 Insertion Control Bit (Sa6)

0 = do not insert data from the TR.TSa6 register into the transmit data stream

1 = insert data from the TR.TSa6 register into the transmit data stream

Bit 1: Additional Bit 7 Insertion Control Bit (Sa7)

0 = do not insert data from the TR.TSa7 register into the transmit data stream

1 = insert data from the TR.TSa7 register into the transmit data stream

Bit 0: Additional Bit 8 Insertion Control Bit (Sa8)

0 = do not insert data from the TR.TSa8 register into the transmit data stream

1 = insert data from the TR.TSa8 register into the transmit data stream

Register Name: **TR.BAWC**
 Register Description: **BERT Alternating Word-Count Rate**
 Register Address: **DBh**

Bit #	7	6	5	4	3	2	1	0
Name	ACNT7	ACNT6	ACNT5	ACNT4	ACNT3	ACNT2	ACNT1	ACNT0
Default	0	0	0	0	0	0	0	0

Bits 0 – 7: Alternating Word-Count Rate Bits 0 to 7 (ACNT0 to ACNT7). ACNT0 is the LSB of the 8-bit alternating word-count rate counter.

Register Name: **TR.BRP1**
 Register Description: **BERT Repetitive Pattern Set Register 1**
 Register Address: **DCh**

Bit #	7	6	5	4	3	2	1	0
Name	RPAT7	RPAT6	RPAT5	RPAT4	RPAT3	RPAT2	RPAT1	RPAT0
Default	0	0	0	0	0	0	0	0

Bits 0 – 7: BERT Repetitive Pattern Set Bits 0 to 7 (RPAT0 to RPAT7) RPAT0 is the LSB of the 32-bit repetitive pattern set.

Register Name: **TR.BRP2**
 Register Description: **BERT Repetitive Pattern Set Register 2**
 Register Address: **DDh**

Bit #	7	6	5	4	3	2	1	0
Name	RPAT15	RPAT14	RPAT13	RPAT12	RPAT11	RPAT10	RPAT9	RPAT8
Default	0	0	0	0	0	0	0	0

Bits 0 – 7: BERT Repetitive Pattern Set Bits 8 to 15 (RPAT8 to RPAT15)

Register Name: **TR.BRP3**
 Register Description: **BERT Repetitive Pattern Set Register 3**
 Register Address: **DEh**

Bit #	7	6	5	4	3	2	1	0
Name	RPAT23	RPAT22	RPAT21	RPAT20	RPAT19	RPAT18	RPAT17	RPAT16
Default	0	0	0	0	0	0	0	0

Bits 0 – 7: BERT Repetitive Pattern Set Bits 16 to 23 (RPAT16 to RPAT23)

Register Name: **TR.BRP4**
 Register Description: **BERT Repetitive Pattern Set Register 4**
 Register Address: **DFh**

Bit #	7	6	5	4	3	2	1	0
Name	RPAT31	RPAT30	RPAT29	RPAT28	RPAT27	RPAT26	RPAT25	RPAT24
Default	0	0	0	0	0	0	0	0

Bits 0 – 7: BERT Repetitive Pattern Set Bits 24 to 31 (RPAT24 to RPAT31). RPAT31 is the LSB of the 32-bit repetitive pattern set.

Register Name: **TR.BC1**
 Register Description: **BERT Control Register 1**
 Register Address: **E0h**

Bit #	7	6	5	4	3	2	1	0
Name	TC	TINV	RINV	PS2	PS1	PS0	LC	RESYNC
Default	0	0	0	0	0	0	0	0

Bit 7: Transmit Pattern Load (TC). A low-to-high transition loads the pattern generator with the pattern that is to be generated. This bit should be toggled from low to high whenever the host wishes to load a new pattern. Must be cleared and set again for subsequent loads.

Bit 6: Transmit Invert-Data Enable (TINV)

0 = do not invert the outgoing data stream

1 = invert the outgoing data stream

Bit 5: Receive Invert-Data Enable (RINV)

0 = do not invert the incoming data stream

1 = invert the incoming data stream

Bits 2 – 4: Pattern Select Bits (PS0 to PS2)

PS 2	PS1	PS0	Pattern Definition
0	0	0	Pseudorandom $2E7 - 1$
0	0	1	Pseudorandom $2E11 - 1$
0	1	0	Pseudorandom $2E15 - 1$
0	1	1	Pseudorandom pattern QRSS. A $2^{20} - 1$ pattern with 14 consecutive zero restrictions.
1	0	0	Repetitive pattern
1	0	1	Alternating word pattern
1	1	0	Modified 55 octet (Daly) pattern. The Daly pattern is a repeating 55 octet pattern that is byte-aligned into the active DS0 time slots. The pattern is defined in an ATIS (Alliance for Telecommunications Industry Solutions) Committee T1 Technical Report Number 25 (November 1993).
1	1	1	Pseudorandom $2E9 - 1$

Bit 1: Load Bit and Error Counters (LC). A low-to-high transition latches the current bit and error counts into registers TR.BBC1/ TR.BBC2/ TR.BBC3/ TR.BBC4 and TR.BEC1/ TR.BEC2/ TR.BEC3 and clears the internal count. This bit should be toggled from low to high whenever the host wishes to begin a new acquisition period. Must be cleared and set again for subsequent loads.

Bit 0: Force Resynchronization (RESYNC). A low-to-high transition forces the receive BERT synchronizer to resynchronize to the incoming data stream. This bit should be toggled from low to high whenever the host wishes to acquire synchronization on a new pattern. Must be cleared and set again for a subsequent resynchronization.

Register Name: **TR.BC2**
 Register Description: **BERT Control Register 2**
 Register Address: **E1h**

Bit #	7	6	5	4	3	2	1	0
Name	EIB2	EIB1	EIB0	SBE	RPL3	RPL2	RPL1	RPL0
Default	0	0	0	0	0	0	0	0

Bits 5 – 7: Error Insert Bits 0 to 2 (EIB0 to EIB2). Automatically inserts bit errors at the prescribed rate into the generated data pattern. Can be used for verifying error-detection features.

EIB2	EIB1	EIB0	Error Rate Inserted
0	0	0	No errors automatically inserted
0	0	1	10E-1
0	1	0	10E-2
0	1	1	10E-3
1	0	0	10E-4
1	0	1	10E-5
1	1	0	10E-6
1	1	1	10E-7

Bit 4: Single Bit-Error Insert (SBE). A low-to-high transition creates a single-bit error. Must be cleared and set again for a subsequent bit error to be inserted.

Bits 0 – 3: Repetitive Pattern Length Bit 3 (RPL0 to RPL3). RPL0 is the LSB and RPL3 is the MSB of a nibble that describes how long the repetitive pattern is. The valid range is 17 (0000) to 32 (1111). These bits are ignored if the receive BERT is programmed for a pseudorandom pattern. To create repetitive patterns fewer than 17 bits in length, the user must set the length to an integer number of the desired length that is less than or equal to 32. For example, to create a 6-bit pattern, the user can set the length to 18 (0001) or to 24 (0111) or to 30 (1101).

Length (bits)	RPL3	RPL2	RPL1	RPL0
17	0	0	0	0
18	0	0	0	1
19	0	0	1	0
20	0	0	1	1
21	0	1	0	0
22	0	1	0	1
23	0	1	1	0
24	0	1	1	1
25	1	0	0	0
26	1	0	0	1
27	1	0	1	0
28	1	0	1	1
29	1	1	0	0
30	1	1	0	1
31	1	1	1	0
32	1	1	1	1

Register Name: **TR.BBC1**
 Register Description: **BERT Bit Count Register 1**
 Register Address: **E3h**

Bit #	7	6	5	4	3	2	1	0
Name	BBC7	BBC6	BBC5	BBC4	BBC3	BBC2	BBC1	BBC0
Default	0	0	0	0	0	0	0	0

Bits 0 – 7: BERT Bit Counter Bits 0 to 7 (BBC0 to BBC7). BBC0 is the LSB of the 32-bit counter.

Register Name: **TR.BBC2**
 Register Description: **BERT Bit Count Register 2**
 Register Address: **E4h**

Bit #	7	6	5	4	3	2	1	0
Name	BBC15	BBC14	BBC13	BBC12	BBC11	BBC10	BBC9	BBC8
Default	0	0	0	0	0	0	0	0

Bits 0 – 7: BERT Bit Counter Bits 8 to 15 (BBC8 to BBC15)

Register Name: **TR.BBC3**
 Register Description: **BERT Bit Count Register 3**
 Register Address: **E5h**

Bit #	7	6	5	4	3	2	1	0
Name	BBC23	BBC22	BBC21	BBC20	BBC19	BBC18	BBC17	BBC16
Default	0	0	0	0	0	0	0	0

Bits 0 – 7: BERT Bit Counter Bits 16 to 23 (BBC16 to BBC23)

Register Name: **TR.BBC4**
 Register Description: **BERT Bit Count Register 4**
 Register Address: **E6h**

Bit #	7	6	5	4	3	2	1	0
Name	BBC31	BBC30	BBC29	BBC28	BBC27	BBC26	BBC25	BBC24
Default	0	0	0	0	0	0	0	0

Bits 0 – 7: BERT Bit Counter Bits 24 to 31 (BBC24 to BBC31). BBC31 is the MSB of the 32-bit counter.

Register Name: **TR.BEC1**
 Register Description: **BERT Error-Count Register 1**
 Register Address: **E7h**

Bit #	7	6	5	4	3	2	1	0
Name	EC7	EC6	EC5	EC4	EC3	EC2	EC1	EC0
Default	0	0	0	0	0	0	0	0

Bits 0 – 7: Error Counter Bits 0 to 7 (EC0 to EC7). EC0 is the LSB of the 24-bit counter.

Register Name: **TR.BEC2**
 Register Description: **BERT Error-Count Register 2**
 Register Address: **E8h**

Bit #	7	6	5	4	3	2	1	0
Name	EC15	EC14	EC13	EC12	EC11	EC10	EC9	EC8
Default	0	0	0	0	0	0	0	0

Bits 0 – 7: Error Counter Bits 8 to 15 (EC8 to EC15)

Register Name: **TR.BEC3**
 Register Description: **BERT Error-Count Register 3**
 Register Address: **E9h**

Bit #	7	6	5	4	3	2	1	0
Name	EC23	EC22	EC21	EC20	EC19	EC18	EC17	EC16
Default	0	0	0	0	0	0	0	0

Bits 0 – 7: Error Counter Bits 16 to 23 (EC16 to EC23). EC0 is the MSB of the 24-bit counter.

Register Name: **TR.BIC**
 Register Description: **BERT Interface Control Register**
 Register Address: **EAh**

Bit #	7	6	5	4	3	2	1	0
Name	—	RFUS	—	TBAT	TFUS	—	BERTDIR	BERTEN
Default	0	0	0	0	0	0	0	0

Bit 6: Receive Framed/Unframed Select (RFUS)

- 0 = BERT is not sent data from the F-bit position (framed)
- 1 = BERT is sent data from the F-bit position (unframed)

Bit 4: Transmit Byte-Align Toggle (TBAT). A 0-to-1 transition forces the BERT to byte align its pattern with the transmit formatter. This bit must be transitioned in order to byte align the Daly pattern.

Bit 3: Transmit Framed/Unframed Select (TFUS)

- 0 = BERT does not source data into the F-bit position (framed)
- 1 = BERT does source data into the F-bit position (unframed)

Bit 1: BERT Direction (BERTDIR)

0 = network

BERT transmits toward the network (TTIP and TRING) and receives from the network (RTIP and RRING). The BERT pattern can be looped back to the receiver internally by using the framer loopback function.

1 = system

BERT transmits toward the system backplane (RSERO) and receives from the system backplane (TSERI).

Bit 0: BERT Enable (BERTEN)

0 = BERT disabled

1 = BERT enabled

Register Name: **TR.ERC**
 Register Description: **Error-Rate Control Register**
 Register Address: **EBh**

Bit #	7	6	5	4	3	2	1	0
Name	WNOE	—	—	CE	ER3	ER2	ER1	ER0
Default	0	0	0	0	0	0	0	0

Bit 7: Write NOE Registers (WNOE). If the host wishes to update to the TR.NOEx registers, this bit must be toggled from a 0 to a 1 after the host has already loaded the prescribed error count into the TR.NOEx registers. The toggling of this bit causes the error count loaded into the TR.NOEx registers to be loaded into the error-insertion circuitry on the next clock cycle. Subsequent updates require that the WNOE bit be set to 0 and then 1 once again.

Bit 4: Constant Errors (CE). When this bit is set high (and the ER0 to ER3 bits are not set to 0000), the error-insertion logic ignores the number-of-error registers (TR.NOE1, TR.NOE2) and generates errors constantly at the selected insertion rate. When CE is set to 0, the TR.NOEx registers determine how many errors are to be inserted.

Bits 0 – 3: Error-Insertion Rate Select Bits (ER0 to ER3)

ER3	ER2	ER1	ER0	Error Rate
0	0	0	0	No errors inserted
0	0	0	1	1 in 16
0	0	1	0	1 in 32
0	0	1	1	1 in 64
0	1	0	0	1 in 128
0	1	0	1	1 in 256
0	1	1	0	1 in 512
0	1	1	1	1 in 1024
1	0	0	0	1 in 2048
1	0	0	1	1 in 4096
1	0	1	0	1 in 8192
1	0	1	1	1 in 16,384
1	1	0	0	1 in 32,768
1	1	0	1	1 in 65,536
1	1	1	0	1 in 131,072
1	1	1	1	1 in 262,144

Register Name: **TR.NOE1**
 Register Description: **Number-of-Errors 1**
 Register Address: **ECh**

Bit #	7	6	5	4	3	2	1	0
Name	C7	C6	C5	C4	C3	C2	C1	C0
Default	0	0	0	0	0	0	0	0

Bits 0 – 7: Number-of-Errors Counter Bits 0 to 7 (C0 to C7). Bit C0 is the LSB of the 10-bit counter.

Register Name: **TR.NOE2**
 Register Description: **Number-of-Errors 2**
 Register Address: **EDh**

Bit #	7	6	5	4	3	2	1	0
Name	—	—	—	—	—	—	C9	C8
Default	0	0	0	0	0	0	0	0

Bits 0 – 1: Number-of-Errors Counter Bits 8 to 9 (C8 to C9). Bit C9 is the MSB of the 10-bit counter.

11.7.1 Number-of-Errors Left Register

The host can read the TR.NOELx registers at any time to determine how many errors are left to be inserted.

Register Name: **TR.NOEL1**
 Register Description: **Number-of-Errors Left 1**
 Register Address: **EEh**

Bit #	7	6	5	4	3	2	1	0
Name	C7	C6	C5	C4	C3	C2	C1	C0
Default	0	0	0	0	0	0	0	0

Bits 0 – 7: Number-of-Errors Left Counter Bits 0 to 7 (C0 to C7). Bit C0 is the LSB of the 10-bit counter.

Register Name: **TR.NOEL2**
 Register Description: **Number-of-Errors Left 2**
 Register Address: **EFh**

Bit #	7	6	5	4	3	2	1	0
Name	—	—	—	—	—	—	C9	C8
Default	0	0	0	0	0	0	0	0

Bits 0 – 1: Number-of-Errors Left Counter Bits 8 to 9 (C8 to C9). Bit C9 is the MSB of the 10-bit counter.

12 FUNCTIONAL TIMING

12.1 Functional Serial I/O Timing

The Serial Interface provides flexible timing to interconnect with a wide variety of serial interfaces. TDEN is an input signal that can be used to enable or block the TSERO data. The “shaded bits” are not clocked by the DS33R11. The TDEN must occur one bit before the effected bit in the TSERO stream. Note that polarity of the TDEN is selectable through LI.TSLCR. In the figure below, TDEN is active low, allowing the bits to clock and inactive high, causing the next data bit not be clocked. TCLKE can be gapped as shown in the following figure. Similarly, the receiver function is governed by RCLKI, RDEN and RSERI. RSERI data will not be provided to the receiver for the bits blocked when RDEN is inactive. The RDEN polarity can be programmed by [LI.RSLCR](#). The RDEN signal must be coincident with the RSERI bit that needs to be blocked.

Figure 12-1. Tx Serial Interface Functional Timing



Figure 12-2. Rx Serial Interface Functional Timing

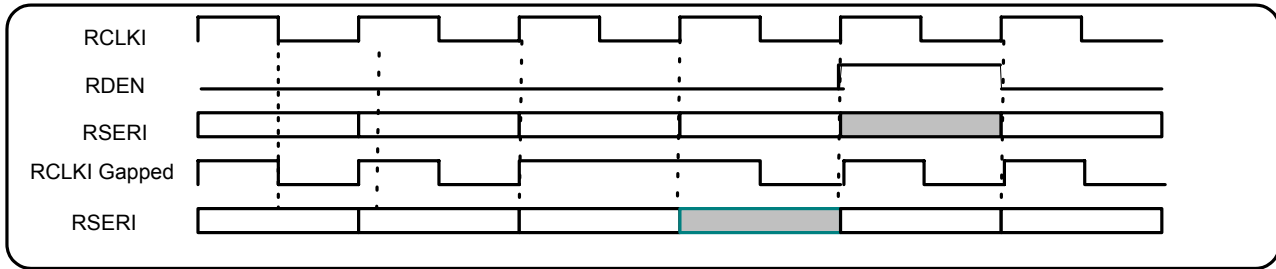

The DS33R11 provides the TBSYNC signal as a byte boundary indication to an external interface when X.86 (LAPS) functionality is selected. The functional timing of TBSYNC is shown in the following figure. TBSYNC is active high on the last bit of the byte being shifted out, and occurs every 8 bits. For the serial receiver interface, RBSYNC is used to provide byte boundary indication to the DS33R11 when X.86 (LAPS) mode is used. The functional timing is shown in [Figure 12-3](#). In X.86 Mode, the receiver expects the RBSYNC byte indicator as shown in [Figure 12-4](#).

Figure 12-3. Transmit Byte Sync Functional Timing

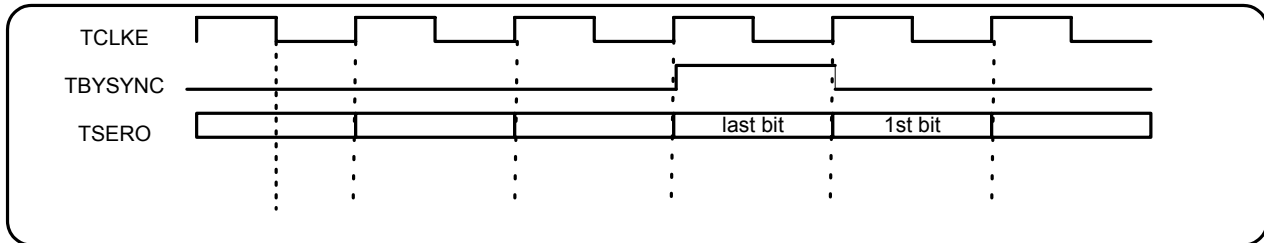
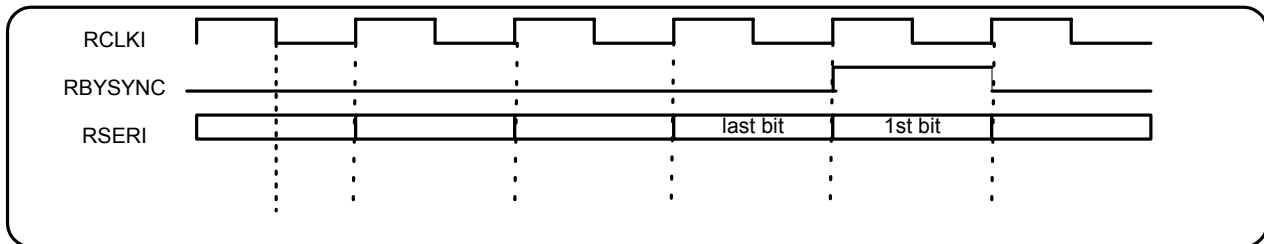

Figure 12-4. Receive Byte Sync Functional Timing



12.2 MII and RMII Interfaces

The MII Interface Transmit Port has its own TX_CLK and data interface. The data TXD [3:0] operates synchronously with TX_CLK. The LSB is presented first. TX_CLK should be 2.5MHz for 10Mbit/s operation and 25MHz for 100Mbit/s operation. TX_EN is valid at the same time as the first byte of the preamble. In DTE Mode TX_CLK is input from the external PHY. In DCE Mode, the DS33R11 provides TX_CLK, derived from an external reference (SYSCLKI).

Figure 12-5. MII Transmit Functional Timing

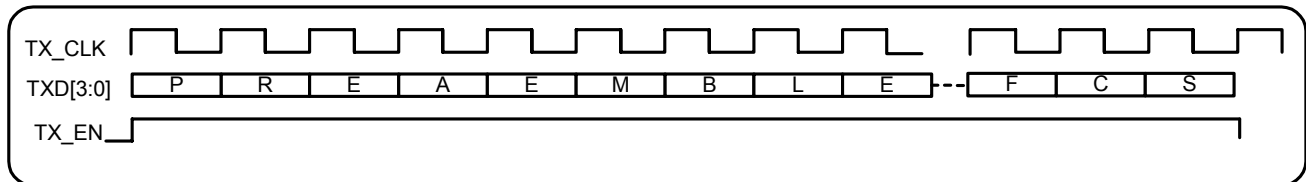

In Half-Duplex (DTE) Mode, the DS33R11 supports CRS and COL signals. CRS is active when the PHY detects transmit or receive activity. If there is a collision as indicated by the COL input, the DS33R11 will replace the data nibbles with jam nibbles. After a “random” time interval, the packet is retransmitted. The MAC will try to send the packet a maximum of 16 times. The jam sequence consists of 55555555h. Note that the COL signal and CRS can be asynchronous to the TX_CLK and are only valid in half duplex mode.

Figure 12-6. MII Transmit Half Duplex with a Collision Functional Timing

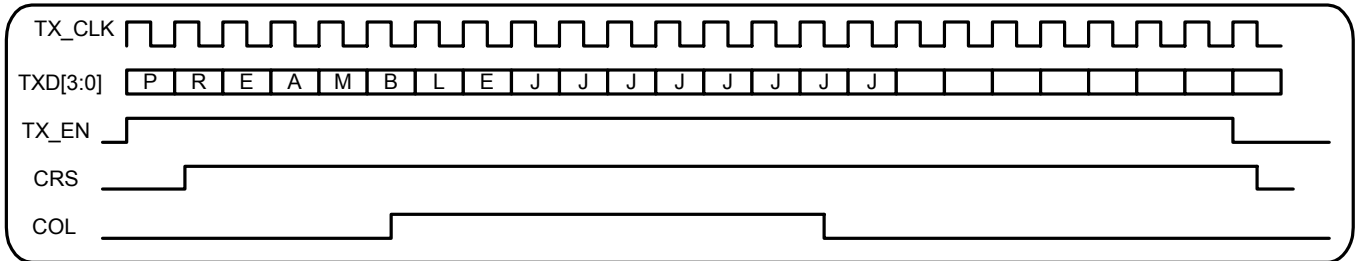

Receive Data (RXD[3:0]) is clocked from the external PHY synchronously with RX_CLK. The RX_CLK signal is 2.5MHz for 10Mbit/s operation and 25MHz for 100Mbit/s operation. RX_DV is asserted by the PHY from the first nibble of the preamble in 100 Mbit/s operation or first nibble of SFD for 10 Mbit/s operation. The data on RXD[3:0] is not accepted by the MAC if RX_DV is low or RX_ERR is high (in DTE mode). RX_ERR should be tied low when in DCE Mode.

Figure 12-7. MII Receive Functional Timing

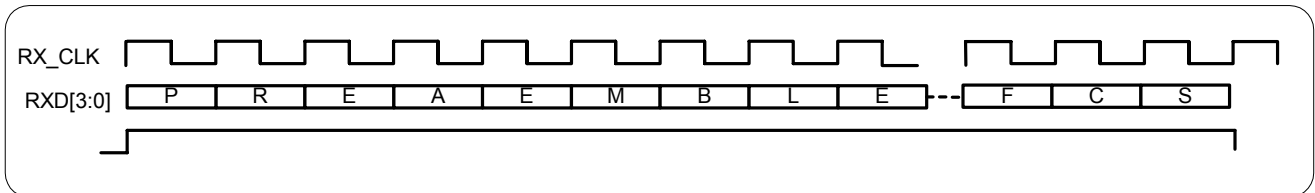

In RMII Mode, TX_EN is high with the first bit of the preamble. The TXD[1:0] is synchronous with the 50MHz REF_CLK. For 10 Mbit/s operation, the data bit outputs are updated every 10 clocks.

Figure 12-8. RMII Transmit Interface Functional Timing

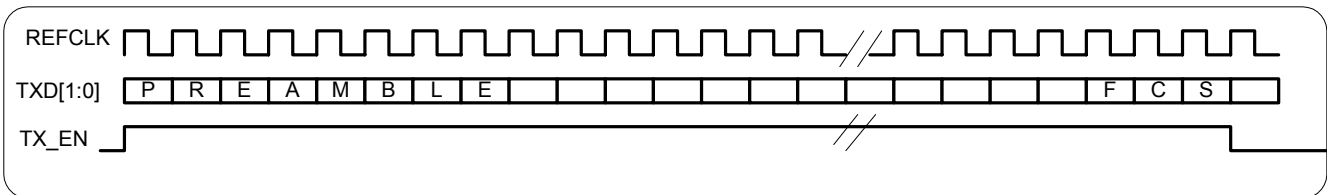

RMII Receive data on RXD[1:0] is expected to be synchronous with the rising edge of the 50 MHz REF_CLK. The data is only valid if CRS_DV is high. The external PHY asynchronously drives CRS_DV low during carrier loss.

Figure 12-9. RMII Receive Interface Functional Timing

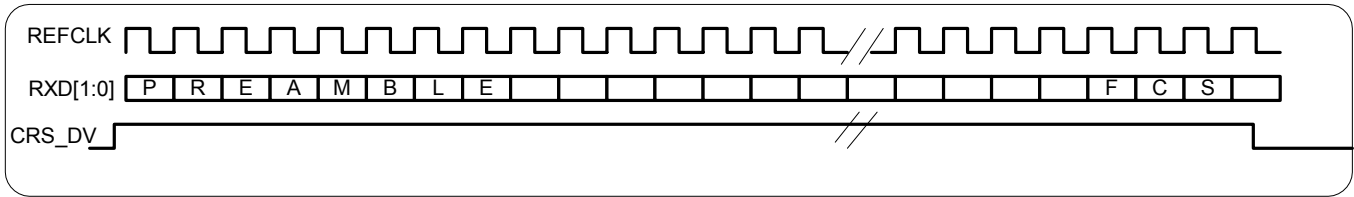

12.3 Transceiver T1 Mode Functional Timing

Figure 12-10. Receive-Side D4 Timing

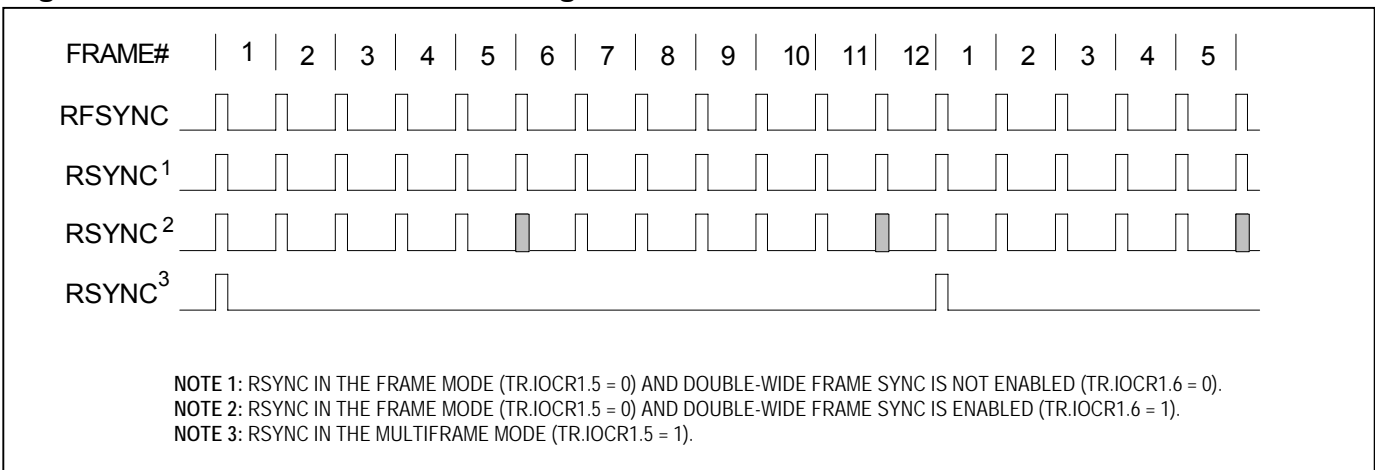

Figure 12-11. Receive-Side ESF Timing

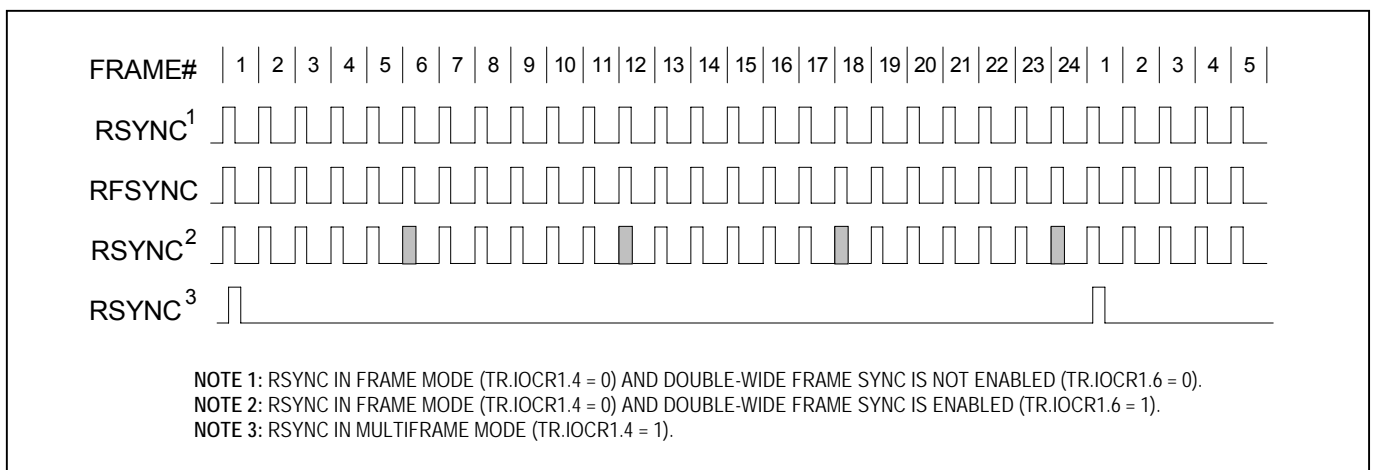

Figure 12-12. Receive-Side Boundary Timing (Elastic Store Disabled)

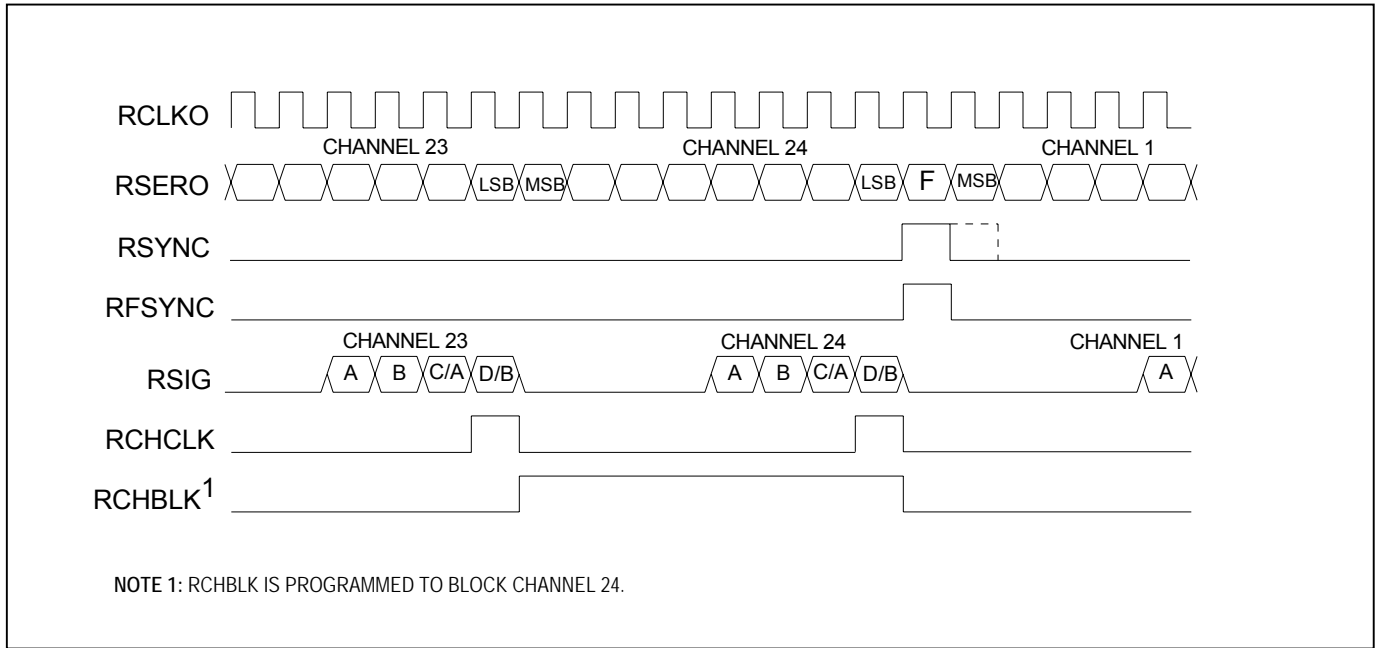

Figure 12-13. Receive-Side 1.544MHz Boundary Timing (Elastic Store Enabled)

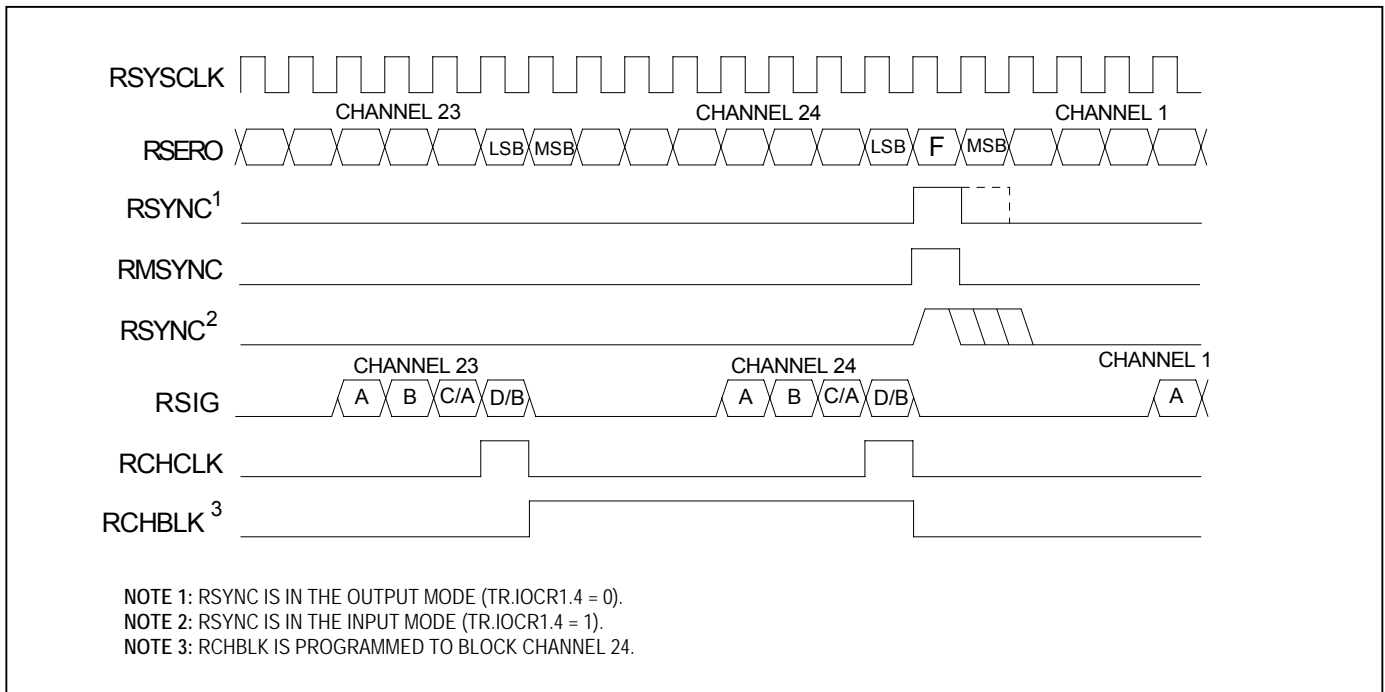

Figure 12-14. Receive-Side 2.048MHz Boundary Timing (Elastic Store Enabled)

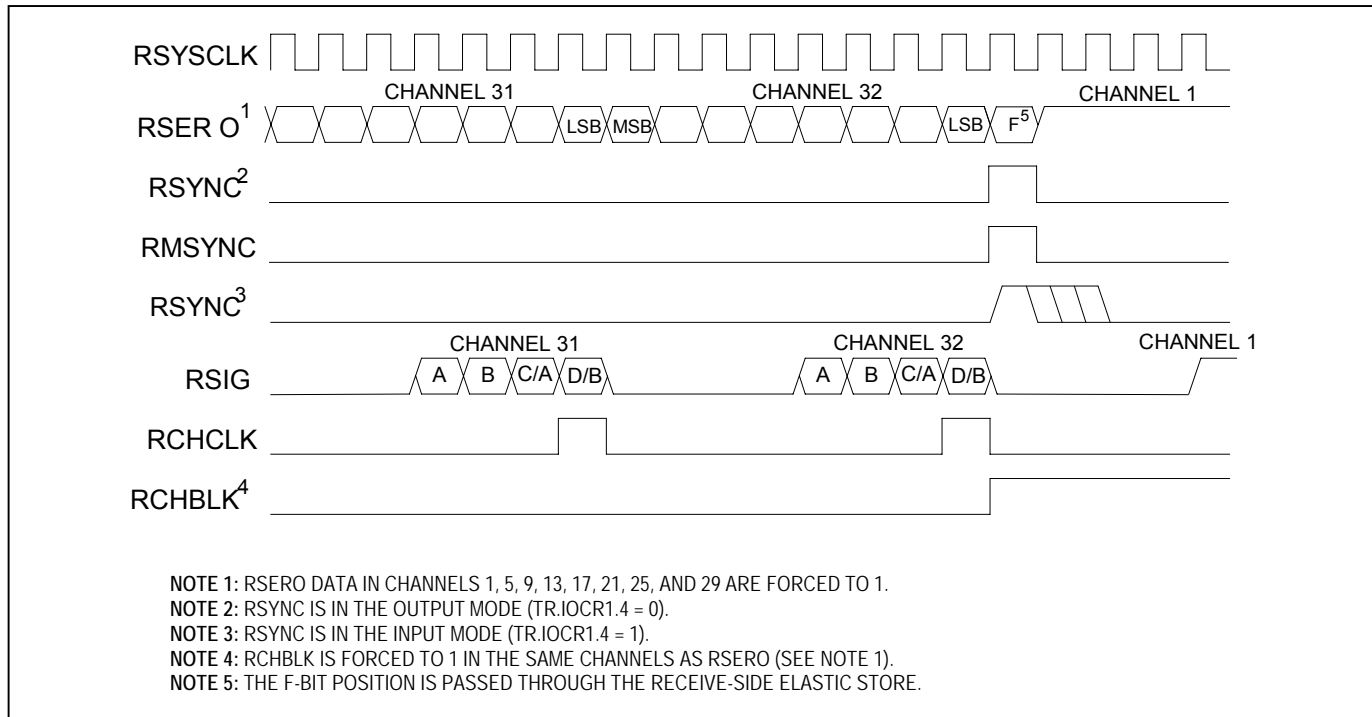

Figure 12-15. Transmit-Side D4 Timing

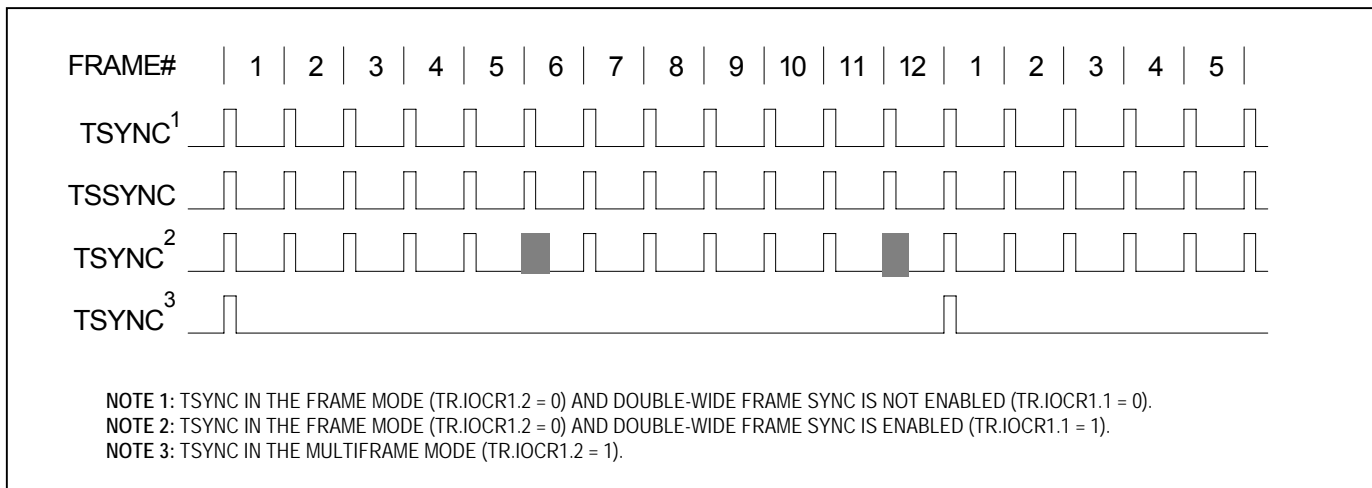

Figure 12-16. Transmit-Side ESF Timing

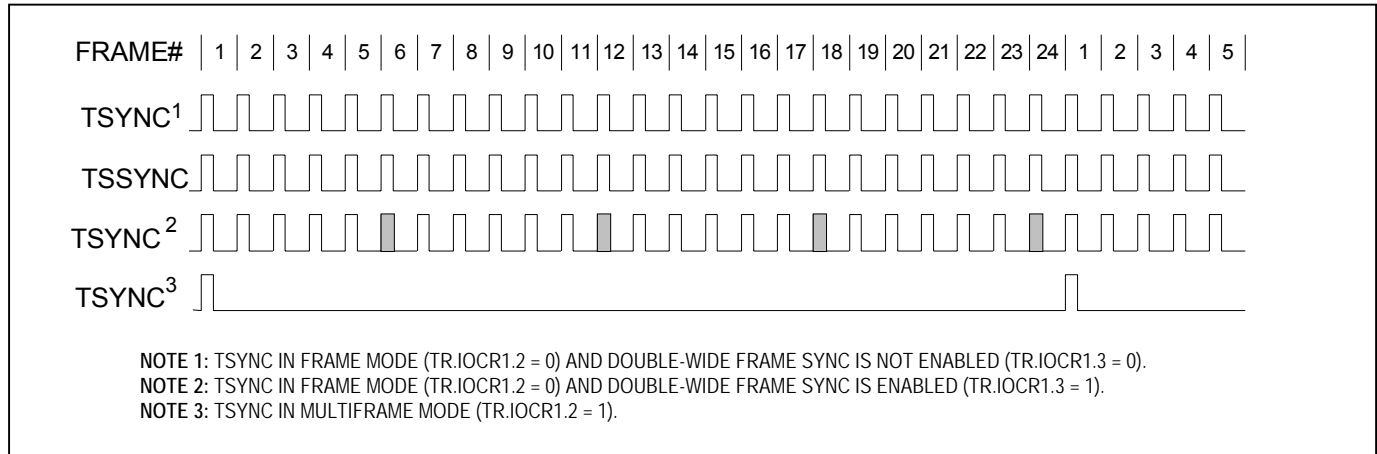

Figure 12-17. Transmit-Side Boundary Timing (with Elastic Store Disabled)

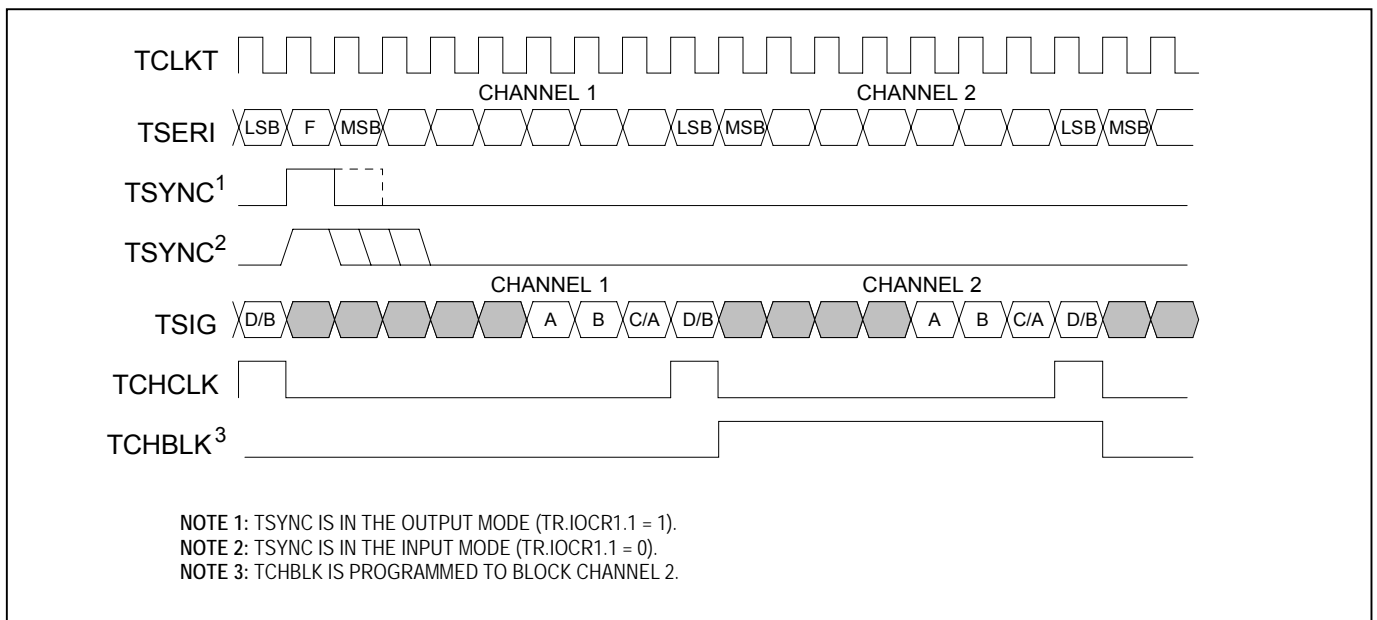

Figure 12-18. Transmit-Side 1.544MHz Boundary Timing (Elastic Store Enabled)

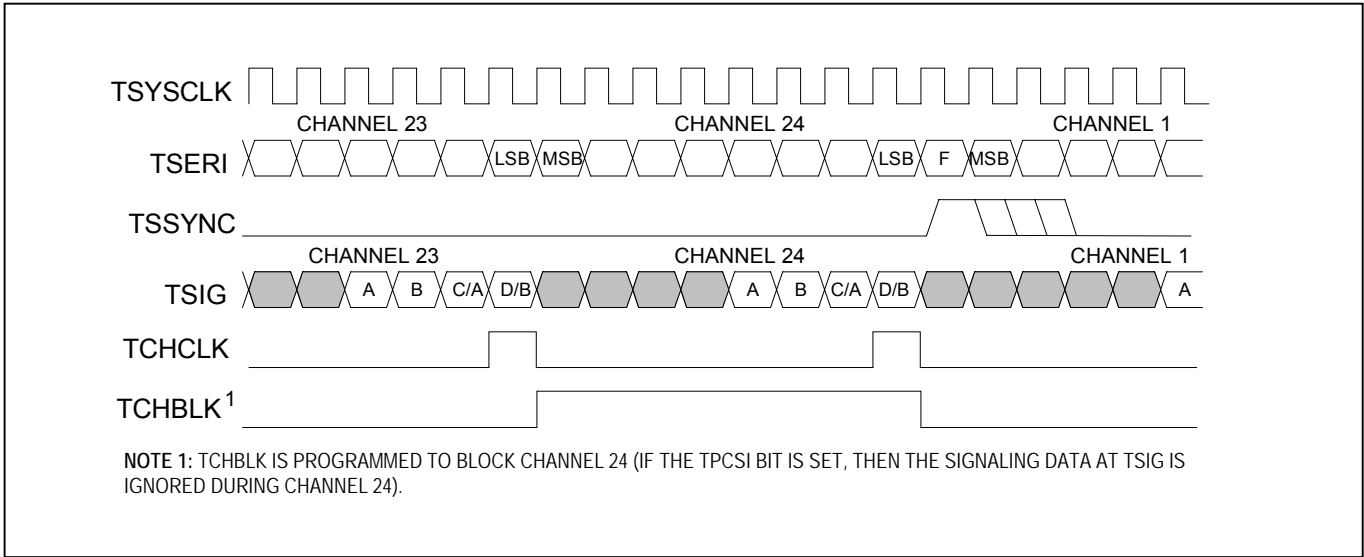
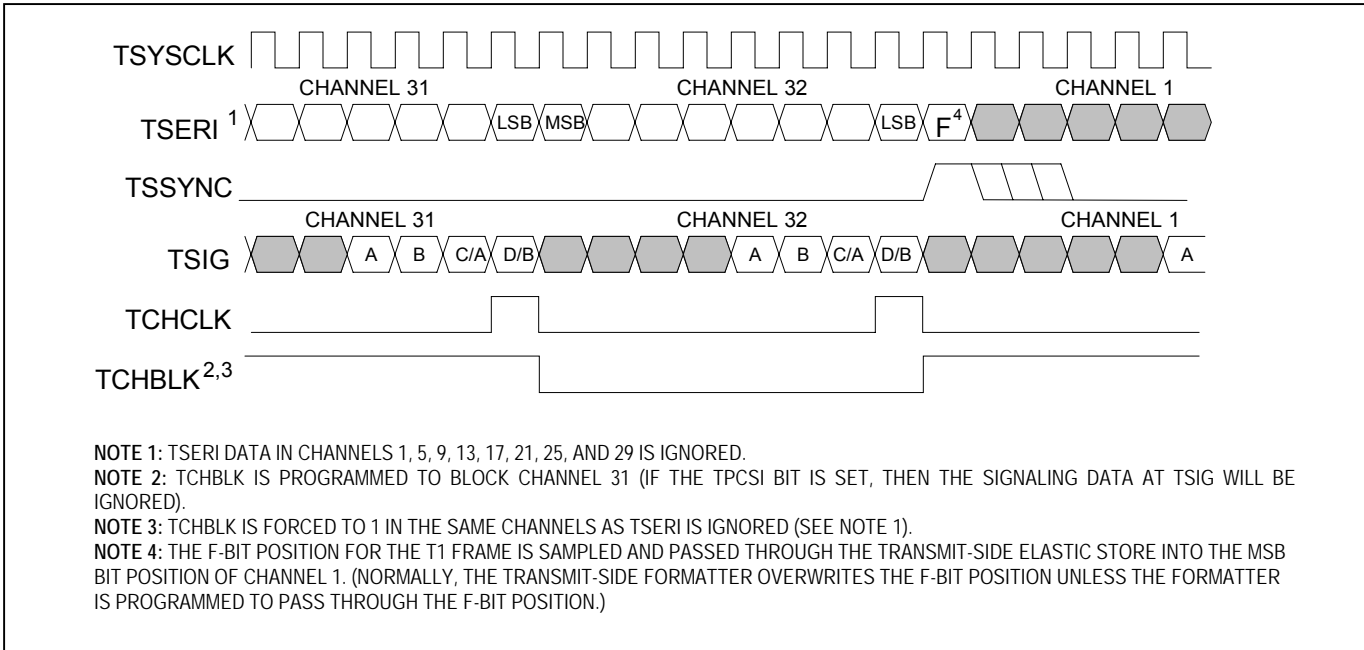

Figure 12-19. Transmit-Side 2.048MHz Boundary Timing (Elastic Store Enabled)



12.4 E1 Mode

Figure 12-20. Receive-Side Timing

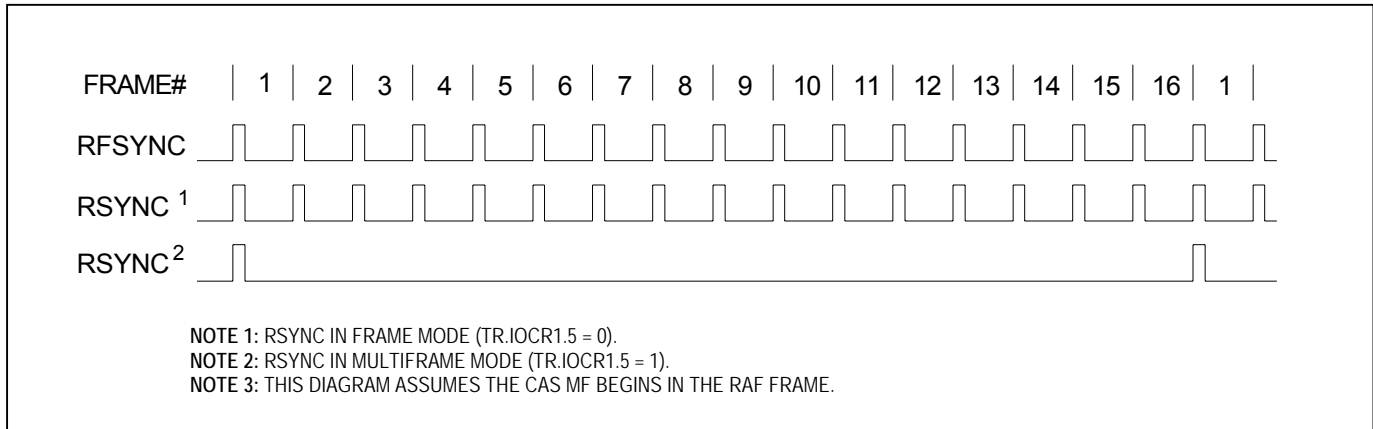

Figure 12-21. Receive-Side Boundary Timing (with Elastic Store Disabled)

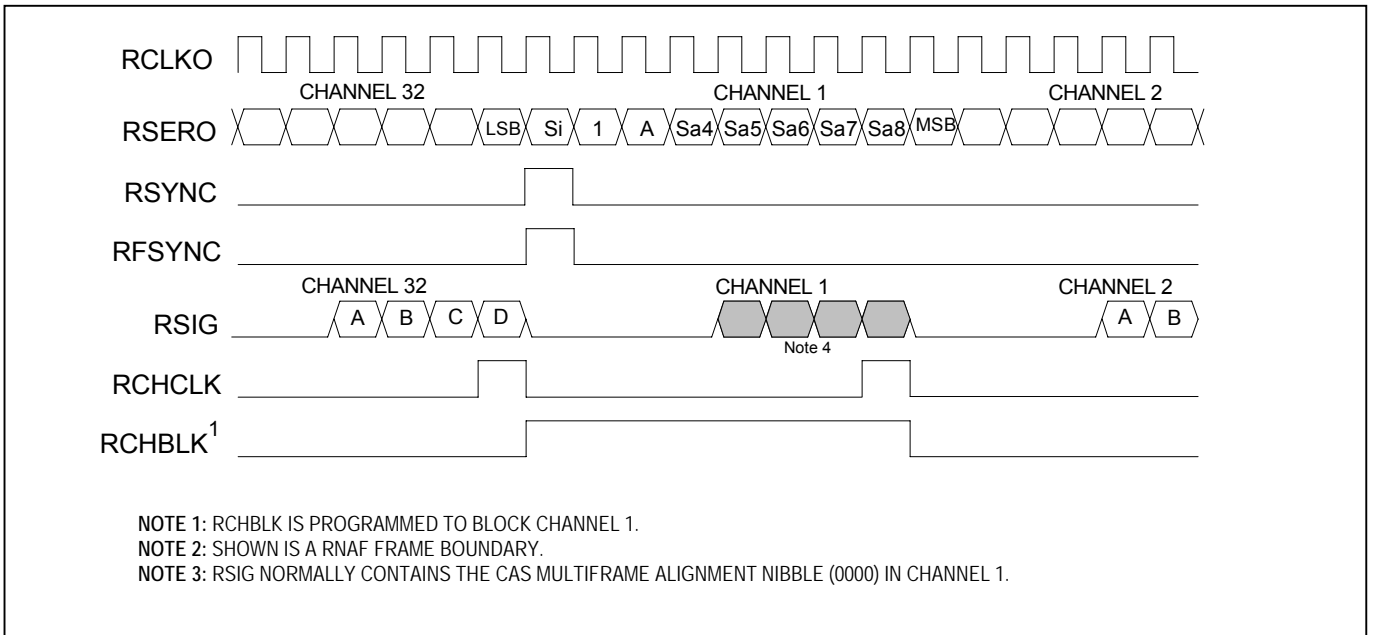

Figure 12-22. Receive-Side Boundary Timing, RSYCLK = 1.544MHz (E-Store Enabled)

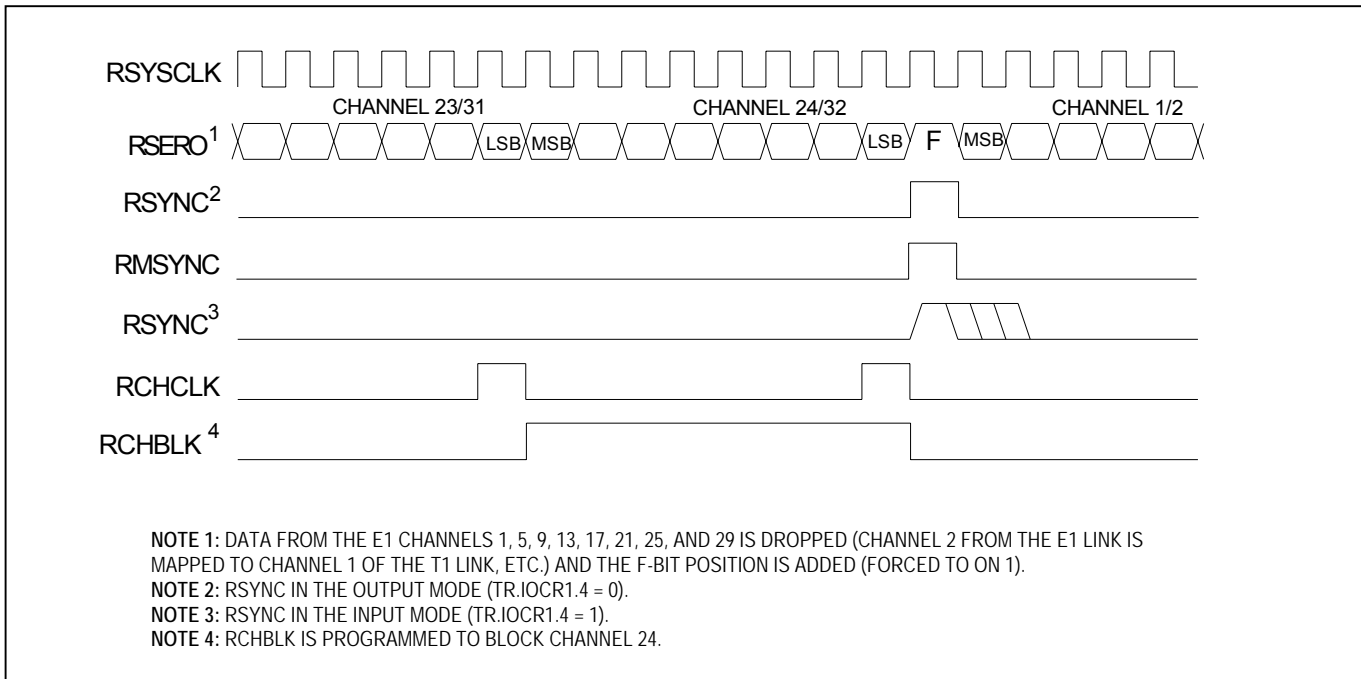

Figure 12-23. Receive-Side Boundary Timing, RSYCLK = 2.048MHz (E-Store Enabled)

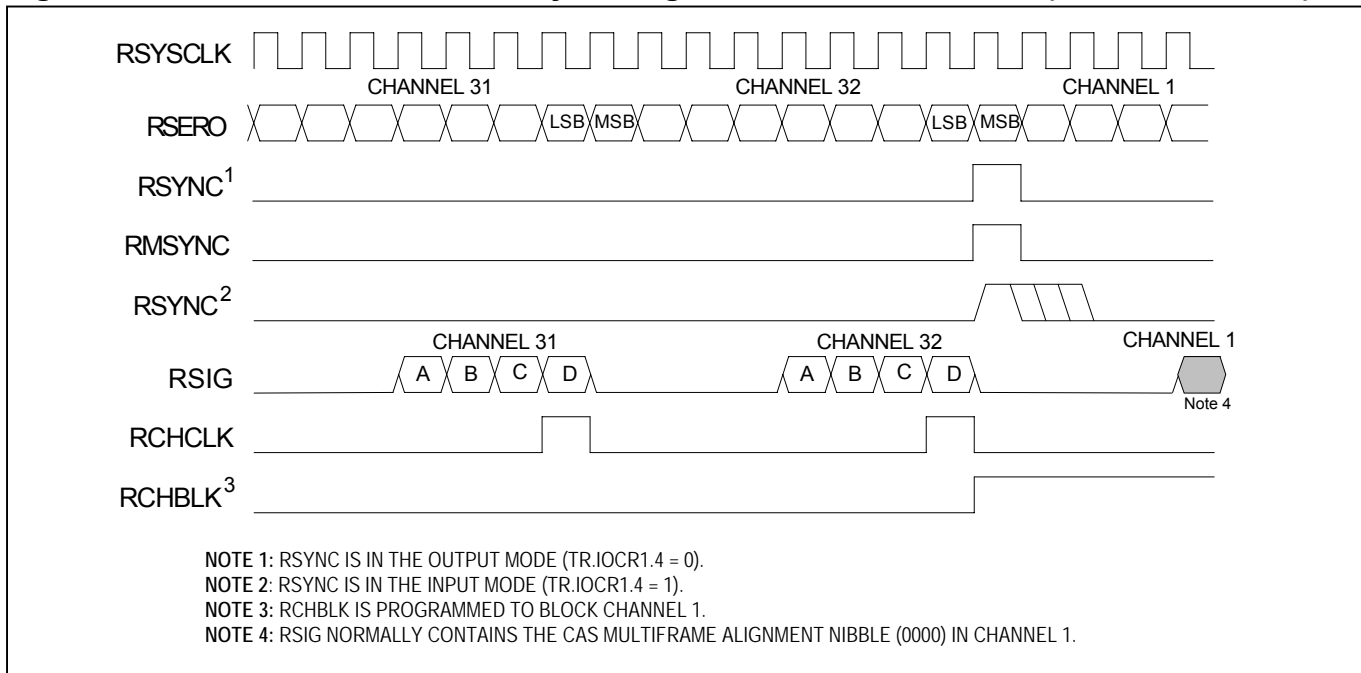

Figure 12-24. G.802 Timing, E1 Mode Only

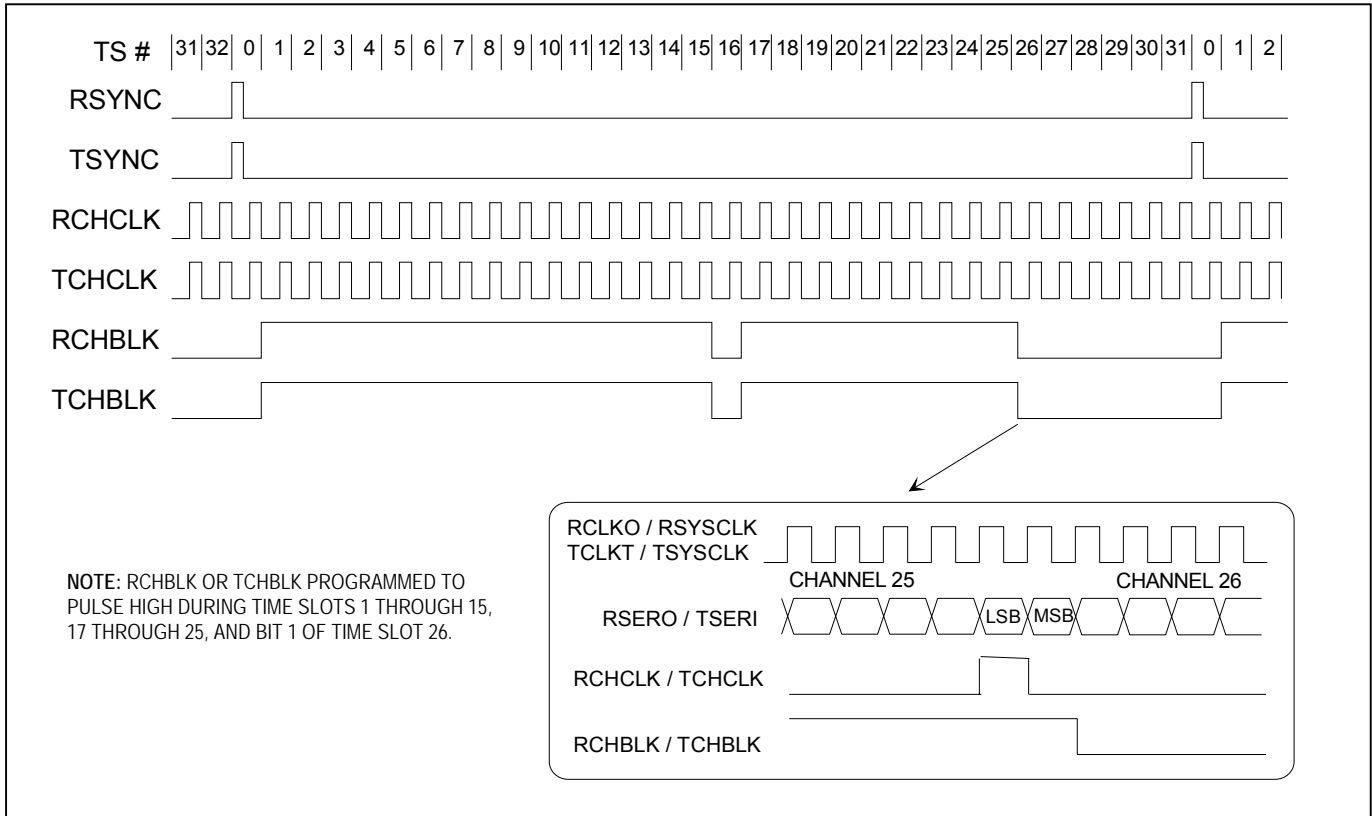

Figure 12-25. Transmit-Side Timing

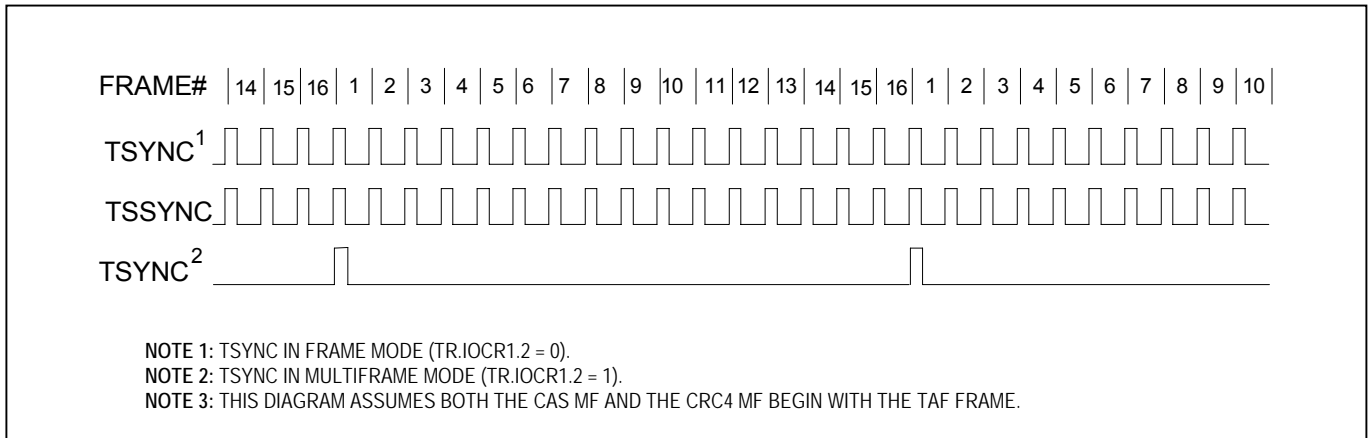

Figure 12-26. Transmit-Side Boundary Timing (Elastic Store Disabled)

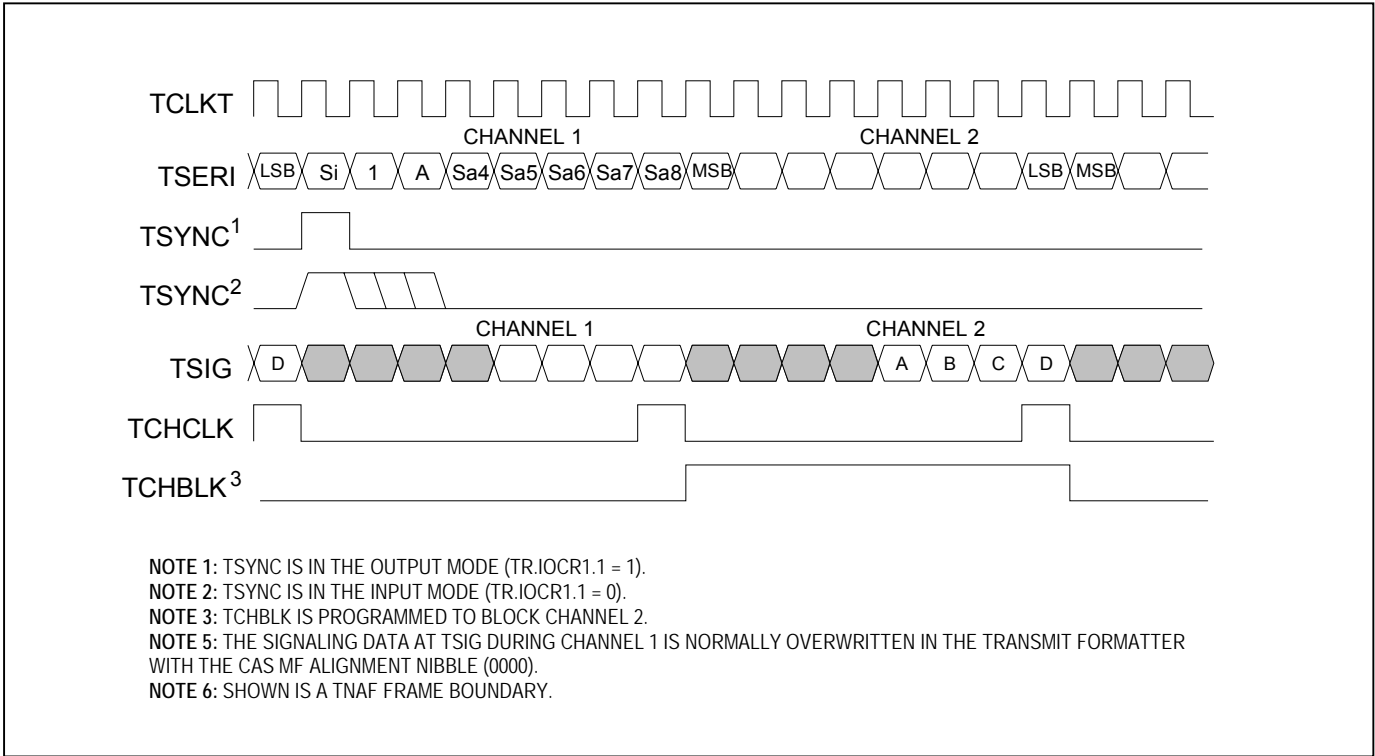

Figure 12-27. Transmit-Side Boundary Timing, TSYSCLK = 1.544MHz (Elastic Store Enabled)

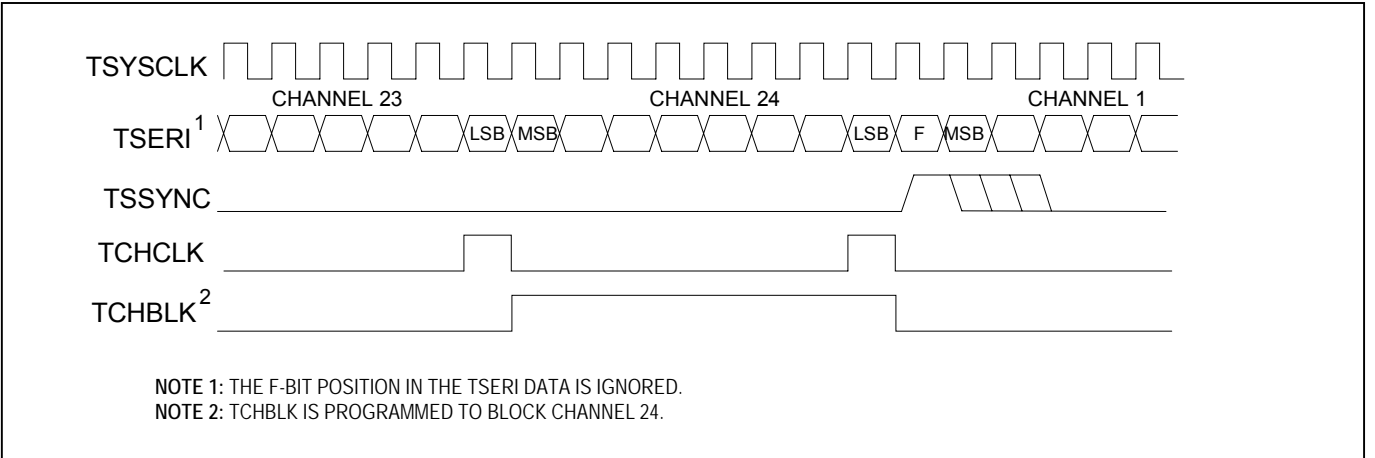
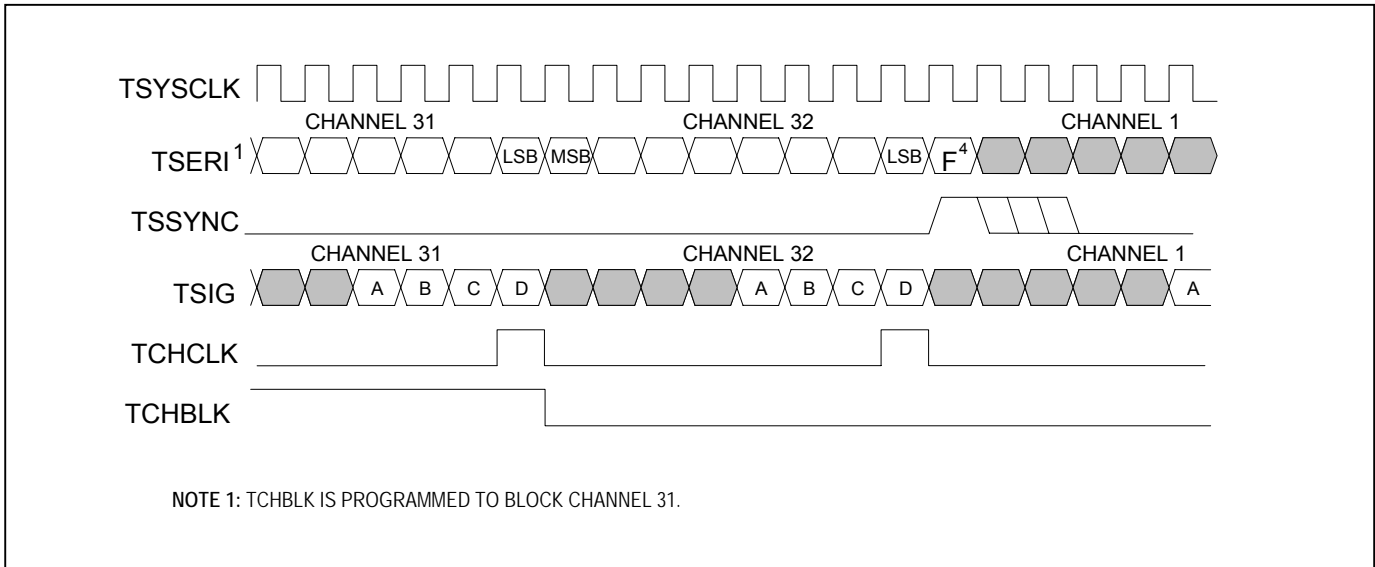

Figure 12-28. Transmit-Side Boundary Timing, TSYSCLK = 2.048MHz (Elastic Store Enabled)



13 OPERATING PARAMETERS

ABSOLUTE MAXIMUM RATINGS

Voltage Range on Any Lead with Respect to V_{SS} (except V_{DD})	-0.5V to +5.5V
Supply Voltage ($V_{DD3.3}$) Range with Respect to V_{SS}	-0.3V to +3.6V
Supply Voltage ($V_{DD1.8}$) with Respect to V_{SS}	-0.3V to +2.0V
Ambient Operating Temperature Range	-40°C to +85°C
Junction Operating Temperature Range	-40°C to +125°C
Storage Temperature Range	-55°C to +125°C
Soldering Temperature	See IPC/JEDEC J-STD-020 Specification

These are stress ratings only and functional operation of the device at these or any other conditions beyond those indicated in the operation sections of this specification is not implied. Exposure to absolute maximum rating conditions for extended periods of time can affect reliability. Ambient Operating Temperature Range is assuming the device is mounted on a JEDEC standard test board in a convection cooled JEDEC test enclosure.

Note: The “typ” values listed below are not production tested.

Table 13-1. Recommended DC Operating Conditions

($V_{DD3.3} = 3.3V \pm 5\%$, $V_{DD1.8} = 1.8V \pm 5\%$, $T_j = -40^\circ\text{C}$ to $+85^\circ\text{C}$.)

PARAMETER	SYMBOL	CONDITIONS	MIN	TYP	MAX	UNITS
Logic 1	V_{IH}		2.35		3.465	V
Logic 0	V_{IL}		-0.3		+0.75	V
Supply ($V_{DD3.3}$) $\pm 5\%$	$V_{DD3.3}$		3.135	3.300	3.465	V
Supply ($V_{DD1.8}$) $\pm 5\%$	$V_{DD1.8}$		1.71	1.8	1.89	V

Table 13-2. DC Electrical Characteristics

($V_{DD3.3} = 3.3V \pm 5\%$, $V_{DD1.8} = 1.8V \pm 5\%$, $T_j = -40^\circ\text{C}$ to $+85^\circ\text{C}$.)

PARAMETER	SYMBOL	CONDITIONS	MIN	TYP	MAX	UNITS
I/O Supply Current ($V_{DD3.3} = 3.465V$)	I_{DDIO}	(Notes 1, 2)		100		mA
Core Supply Current ($V_{DD1.8} = 1.89V$)	I_{DDCORE}	(Notes 1, 2)		30		mA
Lead Capacitance	C_{IO}	(Note 3)		7		pF
Input Leakage	I_{IL}		-10		+10	μA
	I_{ILP}		-50		-10	
Output Leakage (when High-Z)	I_{LO}		-10		+10	μA
Output Voltage	($I_{OH} = -4.0\text{mA}$)	V_{OH}	All outputs	2.35		V
	($I_{OL} = +4.0\text{mA}$)	V_{OL}	All outputs		0.75	
	($I_{OH} = -8.0\text{mA}$)	V_{OH}	REF_CLKO	2.35		
	($I_{OL} = +12.0\text{mA}$)	V_{OL}	TSERO		0.75	
Input Voltage	V_{IL}				0.75	V
	V_{IH}		2.35			

Note 1: Typical power consumption is approximately 400mW.

Note 2: All outputs loaded with rated capacitance; all inputs between V_{DD} and V_{SS} ; inputs with pullups connected to V_{DD} .

Note 3: Value guaranteed by design (GBD).

13.1 Thermal Characteristics

Table 13-3. Thermal Characteristics

PARAMETER	MIN	TYP	MAX
Ambient Temperature (Note 1)	-40°C		+85°C
Junction Temperature (Note 2)			+125°C
Theta-JA (θ_{JA}) in Still Air for 256-Pin 27mm BGA (Notes 2, 3)		+20.3°C/W	

Note 1: The package is mounted on a four-layer JEDEC standard test board.

Note 2: Value guaranteed by design (GBD).

Note 3: Theta-JA (θ_{JA}) is the junction to ambient thermal resistance, when the package is mounted on a four-layer JEDEC standard test board.

Table 13-4. Theta-JA vs. Airflow

AIR FLOW	THETA-JA 256-PIN (27mm) BGA
0m/s (Note 1)	20.3°C/W
1m/s (Note 1)	17.9°C/W
2.5m/s (Note 1)	16.9°C/W

Note 1: Value guaranteed by design (GBD).

13.2 MII Interface

Table 13-5. Transmit MII Interface

(Note 1, [Figure 13-1](#))

PARAMETER	SYMBOL	10Mbps			100Mbps			UNITS
		MIN	TYP	MAX	MIN	TYP	MAX	
TX_CLK Period	t1		400			40		ns
TX_CLK Low Time	t2	140		260	14		26	ns
TX_CLK High Time	t3	140		260	14		26	ns
TX_CLK to TXD, TX_EN Delay	t4	0		20	0		20	ns

Note 1: Timing parameters in this table are guaranteed by design (GBD).

Figure 13-1. Transmit MII Interface Timing

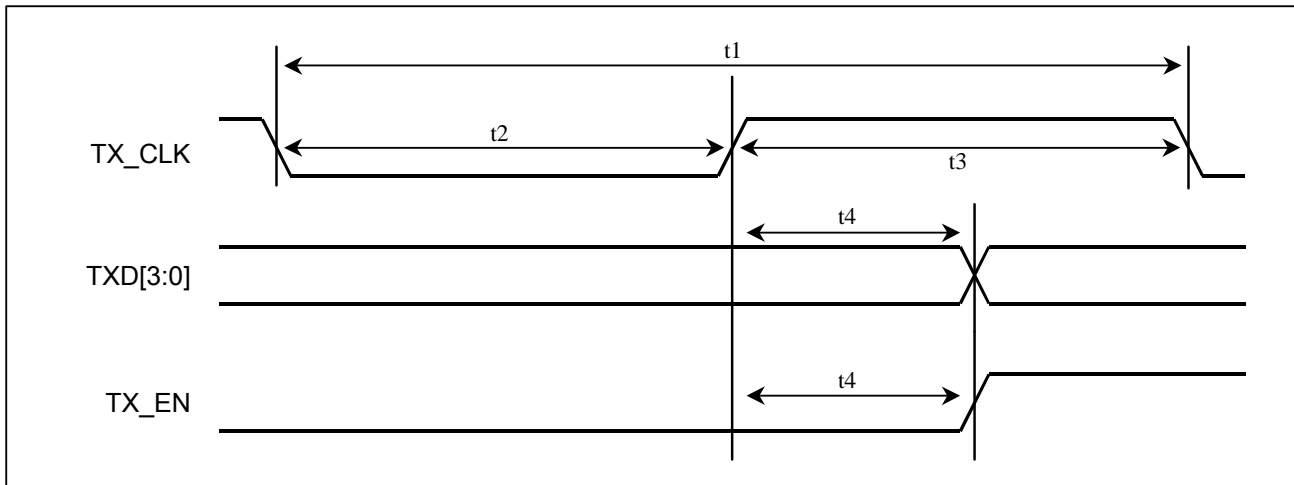

Table 13-6. Receive MII Interface

(Note 1, [Figure 13-2](#))

PARAMETER	SYMBOL	10Mbps			100Mbps			UNITS
		MIN	TYP	MAX	MIN	TYP	MAX	
RX_CLK Period	t5	400			40			ns
RX_CLK Low Time	t6	140		260	14		26	ns
RX_CLK High Time	t7	140		260	14		26	ns
RXD, RX_DV to RX_CLK Setup Time	t8	5			5			ns
RX_CLK to RXD, RX_DV Hold Time	t9	5			5			ns

Note 1: Timing parameters in this table are guaranteed by design (GBD).

Figure 13-2. Receive MII Interface Timing

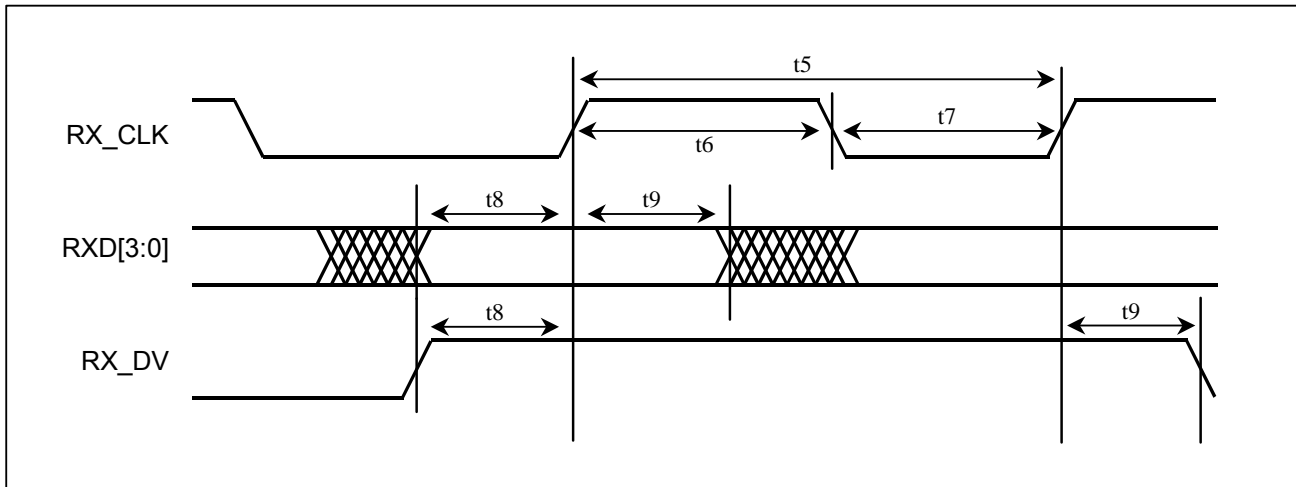

13.3 RMI Interface

Table 13-7. Transmit RMI Interface

(Note 1, [Figure 13-3](#))

PARAMETER	SYMBOL	10Mbps			100Mbps			UNITS
		MIN	TYP	MAX	MIN	TYP	MAX	
REF_CLK Frequency			50MHz ±50ppm			50MHz ±50ppm		
REF_CLK Period	t1		20			20		ns
REF_CLK Low Time	t2	7		13	7		13	ns
REF_CLK High Time	t3	7		13	7		13	ns
REF_CLK to TXD, TX_EN Delay	t4	5		10	5		10	ns

Note 1: Timing parameters in this table are guaranteed by design (GBD).

Figure 13-3. Transmit RMI Interface Timing

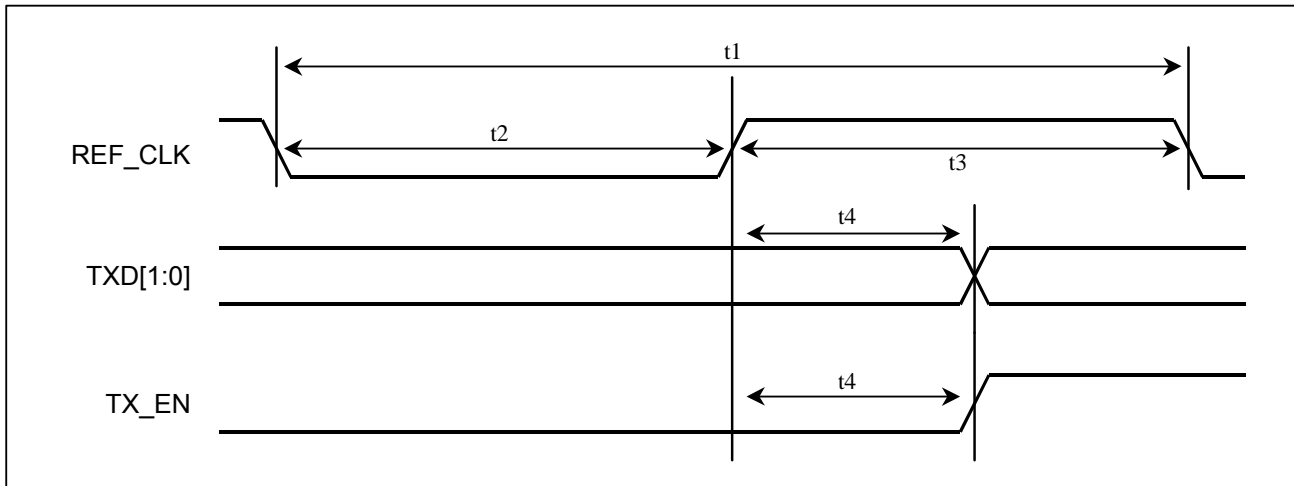

Table 13-8. Receive RMI Interface

(Note 1, [Figure 13-4](#))

PARAMETER	SYMBOL	10Mbps			100Mbps			UNITS
		MIN	TYP	MAX	MIN	TYP	MAX	
REF_CLK Frequency		50MHz ±50ppm			50MHz ±50ppm			MHz
REF_CLK Period	t1	20			20			ns
REF_CLK Low Time	t2	7		13	7		13	ns
REF_CLK High Time	t3	7		13	7		13	ns
RXD, CRS_DV to REF_CLK Setup Time	t8	5			5			ns
REF_CLK to RXD, CRS_DV Hold Time	t9	5			5			ns

Note 1: Timing parameters in this table are guaranteed by design (GBD).

Figure 13-4. Receive RMI Interface Timing

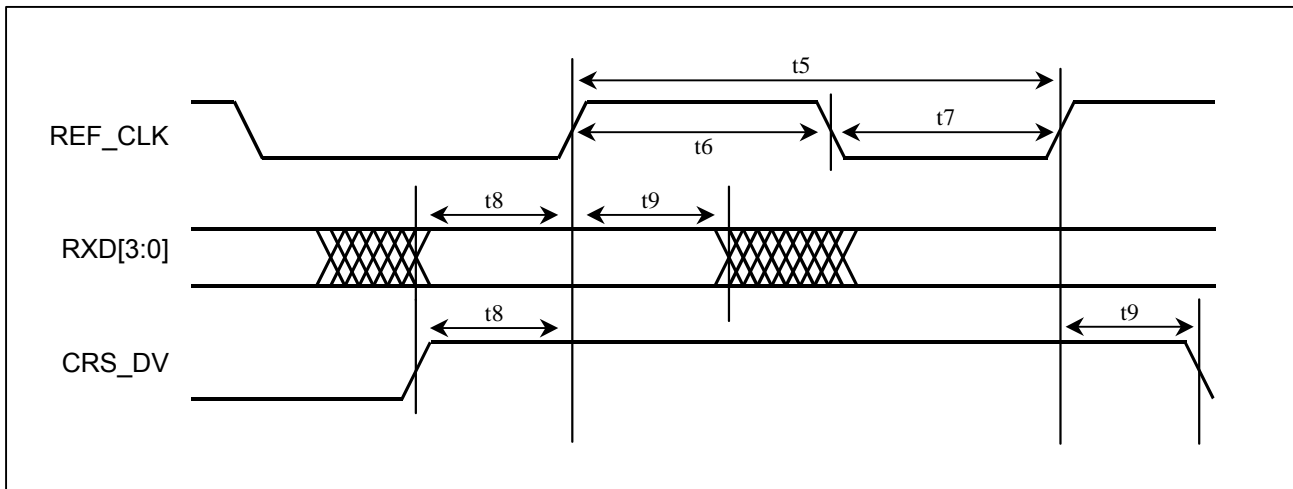

13.4 MDIO Interface

Table 13-9. MDIO Interface

(Note 1, [Figure 13-5](#))

PARAMETER	SYMBOL	MIN	TYP	MAX	UNITS
MDC Frequency			1.67		MHz
MDC Period	t1	540	600	660	ns
MDC Low Time	t2	270	300	330	ns
MDC High Time	t3	270	300	330	ns
MDC to MDIO Output Delay	t4	20		10	ns
MDIO Setup Time	t5	10			ns
MDIO Hold Time	t6	20			ns

Note 1: Timing parameters in this table are guaranteed by design (GBD).

Figure 13-5. MDIO Interface Timing

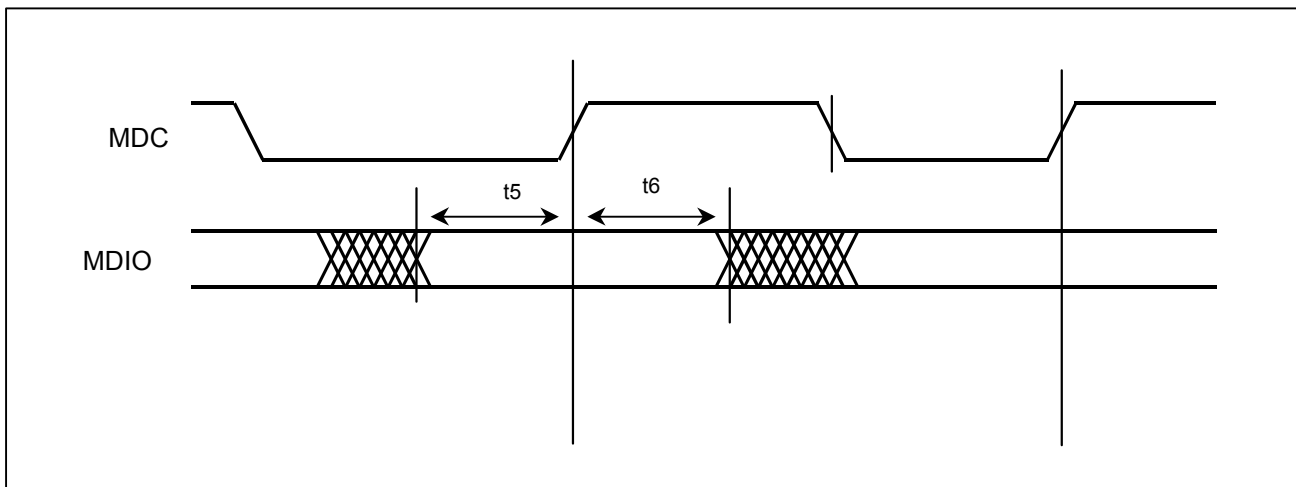
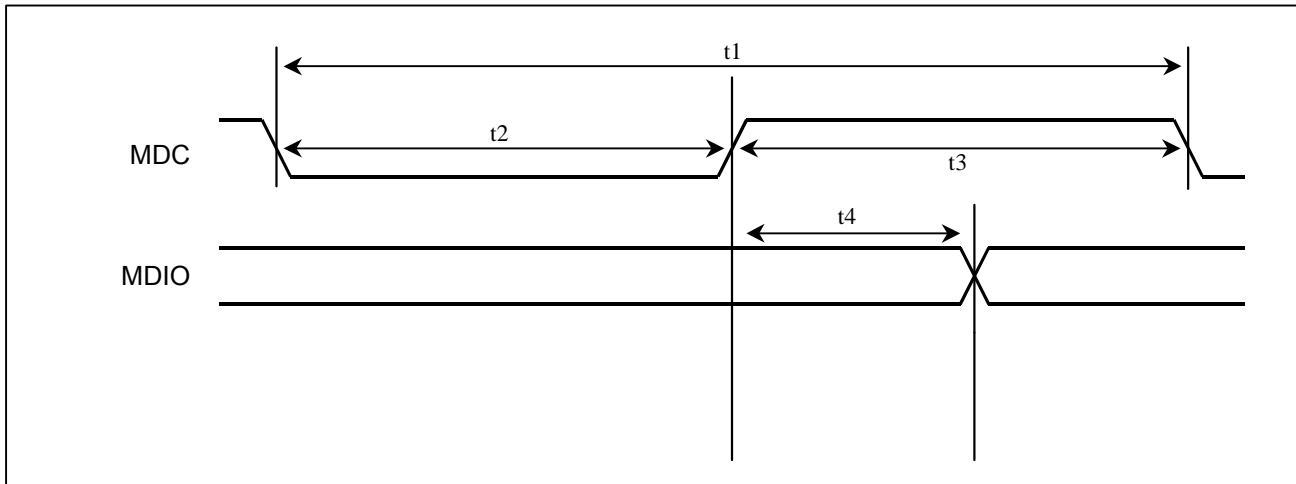

13.5 Transmit WAN Interface

Table 13-10. Transmit WAN Interface

(Note 1, [Figure 13-6](#))

PARAMETER	SYMBOL	MIN	TYP	MAX	UNITS
TCLKE Frequency				52	MHz
TCLKE Period	t1	19.2			ns
TCLKE Low Time	t2	8			ns
TCLKE High Time	t3	8			ns
TCLKE to TSERO Output Delay	t4	3		10	ns
TCLKE to TBSYNC Setup Time	t5	3.5			ns
TBSYNC Hold Time	t6	7			ns
TCLKE to TDEN Output Delay	t7	3		10	ns

Note 1: Timing parameters in this table are guaranteed by design (GBD).

Figure 13-6. Transmit WAN Interface Timing

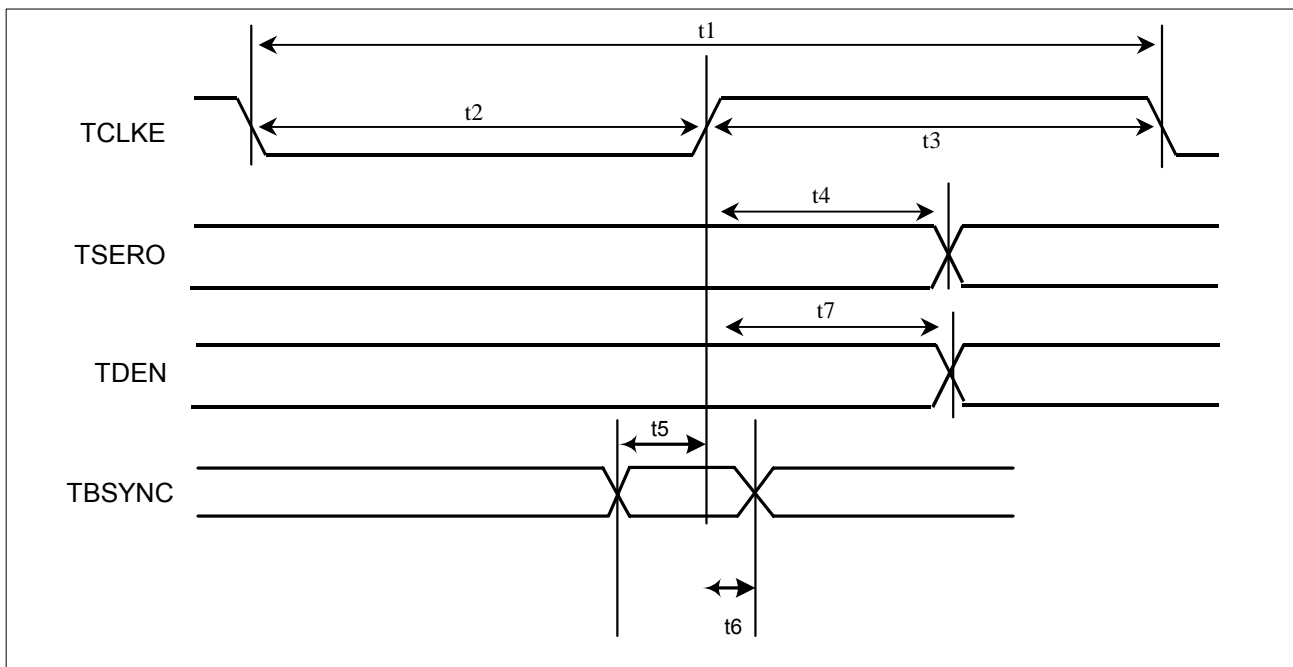

13.6 Receive WAN Interface

Table 13-11. Receive WAN Interface

(Note 1, [Figure 13-7](#))

PARAMETER	SYMBOL	MIN	TYP	MAX	UNITS
RCLKI Frequency				52	MHz
RCLKI Period	t1	19.2			ns
RCLKI Low Time	t2	8			ns
RCLKI High Time	t3	8			ns
RSERI Setup Time	t4	7			ns
RDEN Setup Time	t4	7			ns
RBSYNC Setup Time	t4	7			ns
RDEN Hold Time	t5	2			ns
RBSYNC Hold Time	t5	2			ns
RDEN Hold Time	t5	2			ns
RBSYNC Hold Time	t5	2			ns

Note 1: Timing parameters in this table are guaranteed by design (GBD).

Figure 13-7. Receive WAN Interface Timing

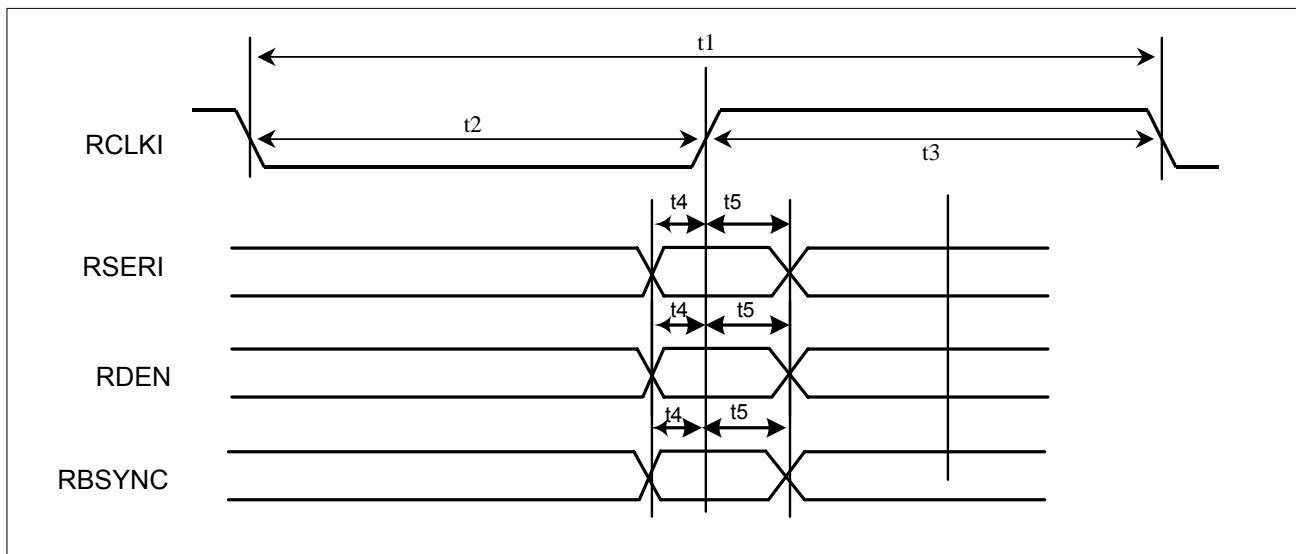

13.7 SDRAM Timing

Table 13-12. SDRAM Interface Timing

(Note 1, [Figure 13-8](#))

PARAMETER	SYMBOL	100 MHz			UNITS
		MIN	TYP	MAX	
SDCLKO Period	t1	9.7	10	10.3	ns
SDCLKO Duty Cycle	t2	4		6	ns
SDCLKO to SDATA Valid Write to SDRAM	t3			7	ns
SDCLKO to SDATA Drive On Write to SDRAM	t4	4			ns
SDCLKO to SDATA Invalid Write to SDRAM	t5	3			ns
SDCLKO to SDATA Drive Off Write to SDRAM	t6			4	ns
SDATA to SDCLKO Setup Time Read from SDRAM	t7	2			ns
SDCLKO to SDATA Hold Time Read from SDRAM	t8			2	ns
SDCLKO to \overline{SRAS} , \overline{SCAS} , \overline{SWE} , \overline{SDCS} Active Read or Write to SDRAM	t9			5	ns
SDCLKO TO \overline{SRAS} , \overline{SCAS} , \overline{SWE} , \overline{SDCS} Inactive Read or Write to SDRAM	t10	2			ns
SDCLKO to SDA, SBA Valid Read or Write to SDRAM	t11			7	ns
SDCLKO TO SDA, SBA Invalid Read or write to SDRAM	t12	2			ns
SDCLKO to SDMASK Valid Read or write to SDRAM	t13			5	ns
SDCLKO TO SDMASK Invalid Read or write to SDRAM	t14	2			ns

Note 1: Timing parameters in this table are guaranteed by design (GBD).

Figure 13-8. SDRAM Interface Timing

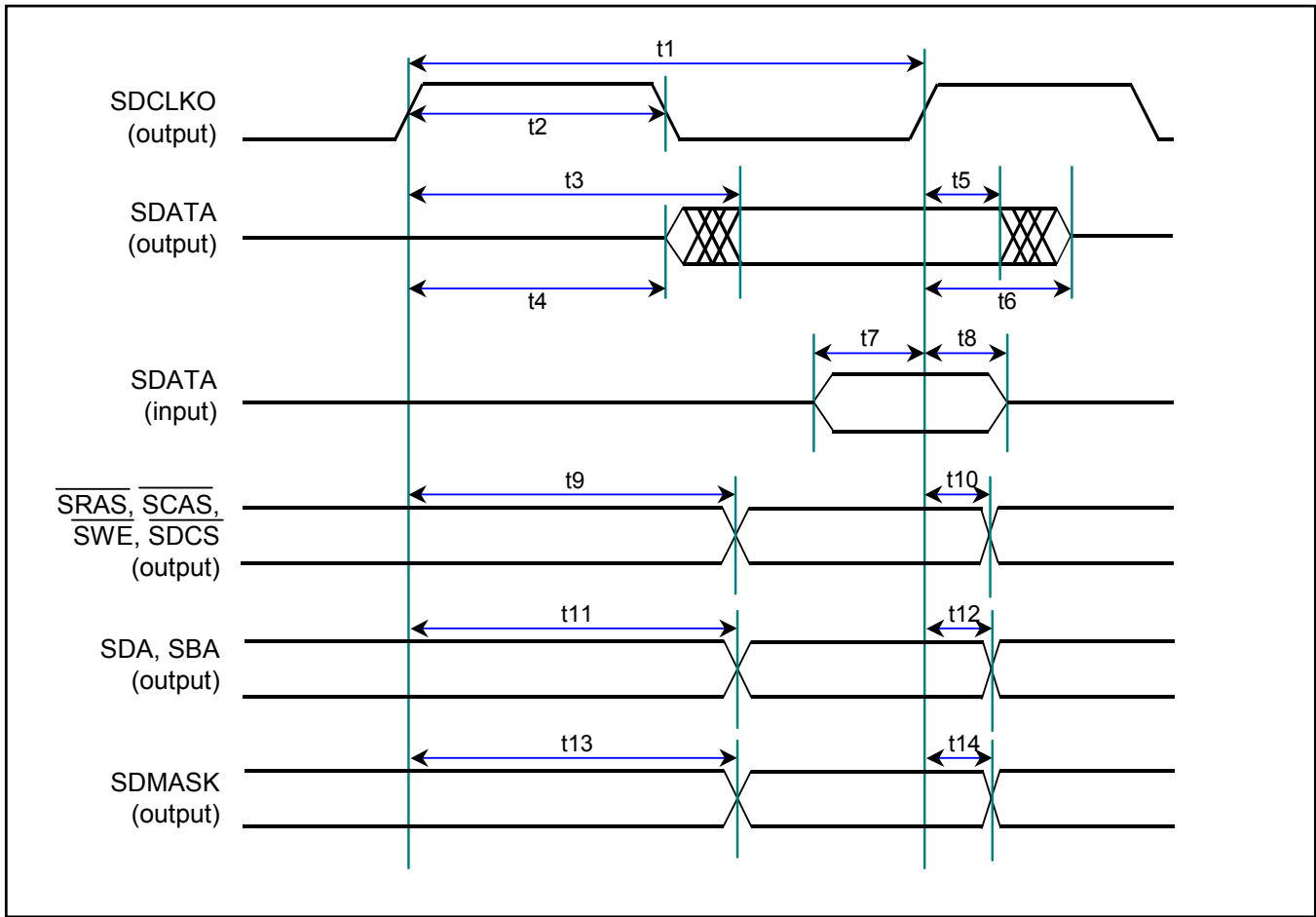

13.8 Microprocessor Bus AC Characteristics

Table 13-13. AC Characteristics—Microprocessor Bus Timing

(VDD3.3 = 3.3V \pm 5%, VDD1.8 = 1.8V \pm 5%, T_j = -40°C to +85°C.) (Note 1, [Figure 13-9](#), [Figure 13-10](#), [Figure 13-11](#), and [Figure 13-12](#))

PARAMETER	SYMBOL	MIN	TYP	MAX	UNITS
Setup Time for A[12:0] Valid to \overline{CS} Active	t1	0			ns
Setup Time for \overline{CS} Active to Either \overline{RD} or \overline{WR} Active	t2	0			ns
Delay Time from either \overline{RD} or \overline{DS} Active to DATA[7:0] Valid	t3			75	ns
Hold Time from either \overline{RD} or \overline{WR} Inactive to \overline{CS} Inactive	t4	0			ns
Hold Time from \overline{CS} or \overline{RD} or \overline{DS} Inactive to DATA[7:0] Tri-State	t5	5		20	ns
Wait Time from \overline{RW} Active to Latch Data	t6	80			ns
Data Set Up Time to \overline{DS} Active	t7	10			ns
Data Hold Time from \overline{RW} Inactive	t8	2			ns
Address Hold from \overline{RW} Inactive	t9	0			ns
Write Access to Subsequent Write/Read Access Delay Time	t10	80			ns

Note 1: Timing parameters in this table are guaranteed by design (GBD).

Figure 13-9. Intel Bus Read Timing (MODEC = 00)

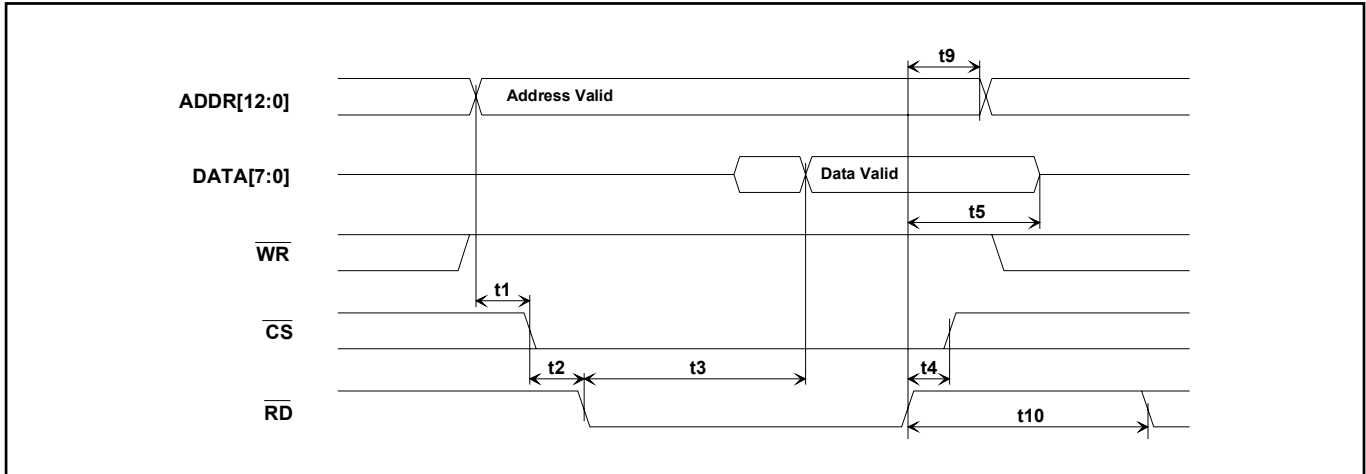

Figure 13-10. Intel Bus Write Timing (MODEC = 00)

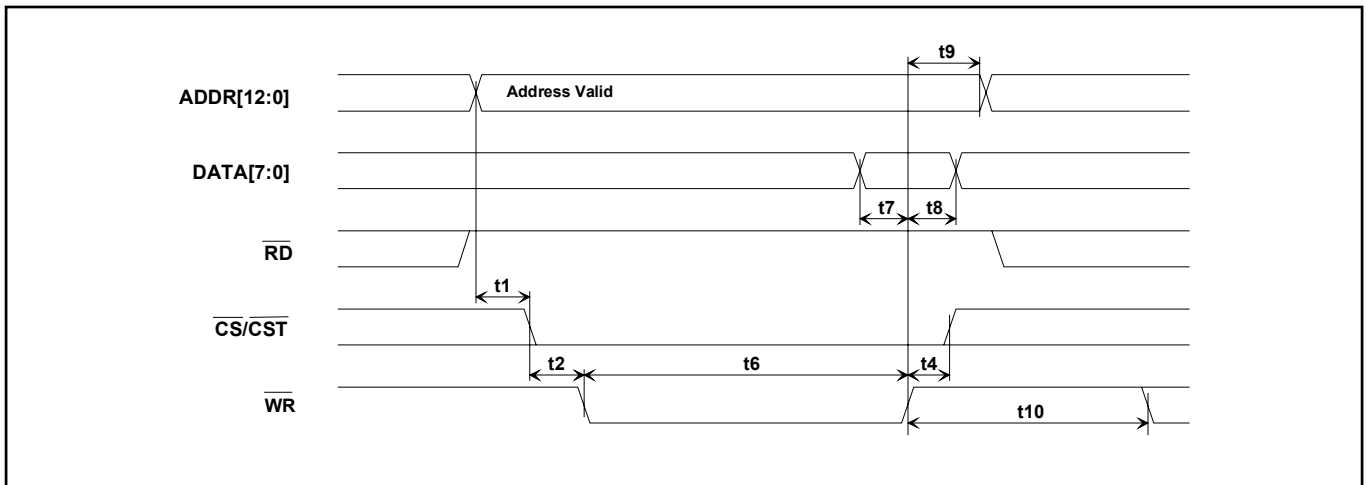

Figure 13-11. Motorola Bus Read Timing (MODEC = 01)

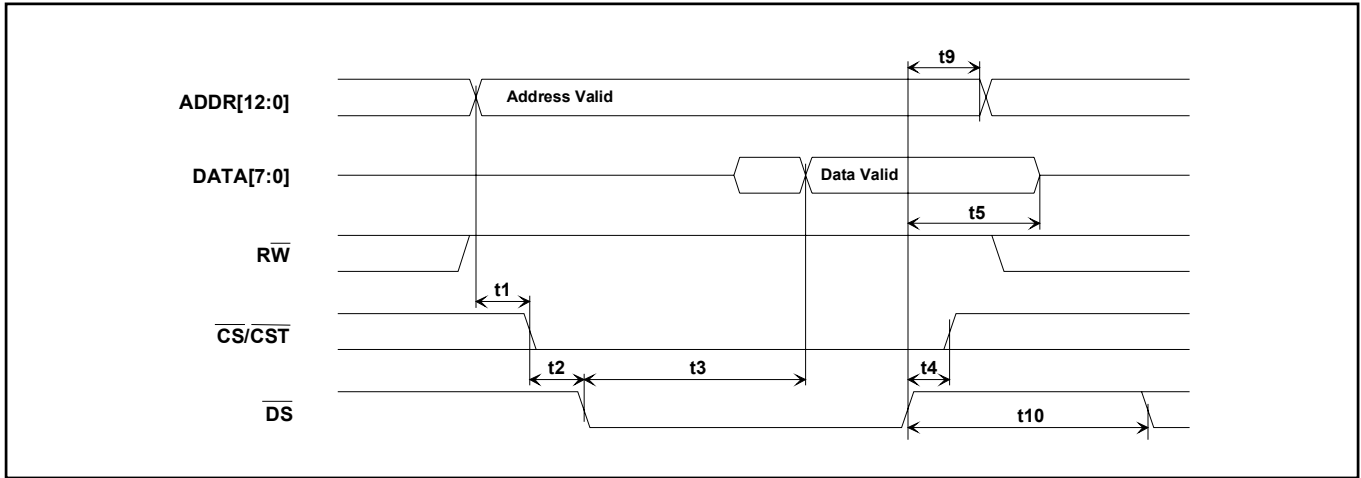
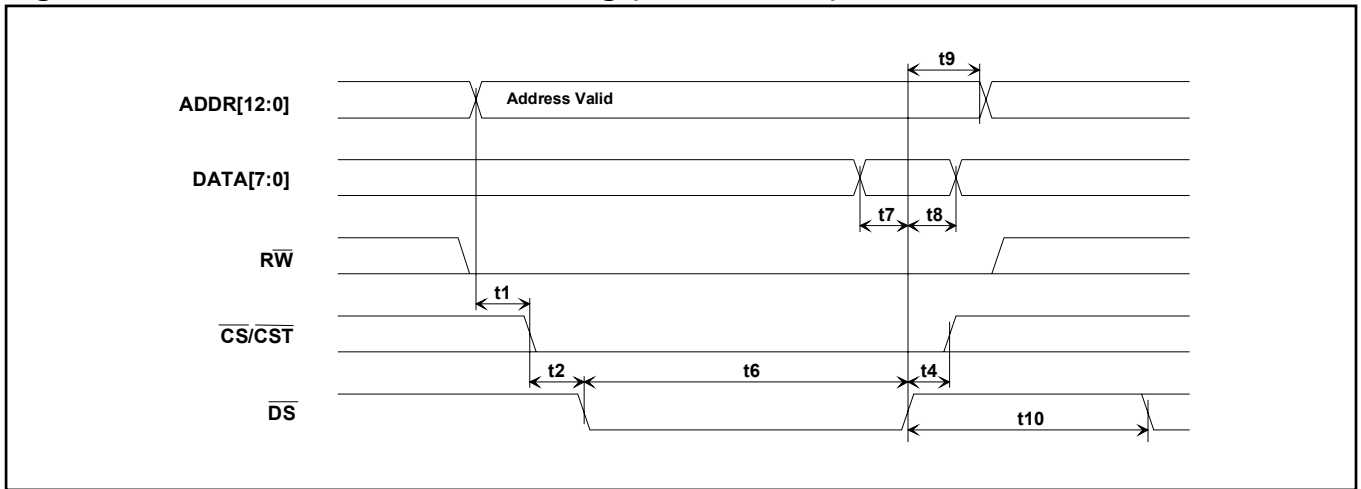

Figure 13-12. Motorola Bus Write Timing (MODEC = 01)



13.9 AC Characteristics: Receive-Side

Table 13-14. AC Characteristics: Receive Side

($V_{DD} = 3.3V \pm 5\%$, $T_A = -40^\circ C$ to $+85^\circ C$.) (Note 1, [Figure 13-3](#), [Figure 13-14](#), and [Figure 13-15](#))

PARAMETER	SYMBOL	CONDITIONS	MIN	TYP	MAX	UNITS
RDCLKO Period	t_{LP}			488 (E1)		ns
				648 (T1)		
RDCLKO Pulse Width	t_{LH}	(Note 2)	200	$0.5 t_{LP}$		ns
	t_{LL}	(Note 2)	200	$0.5 t_{LP}$		
RDCLKO Pulse Width	t_{LH}	(Note 3)	150	$0.5 t_{LP}$		ns
	t_{LL}	(Note 3)	150	$0.5 t_{LP}$		
RDCLKI Period	t_{CP}			488 (E1)		ns
				648 (T1)		
RDCLKI Pulse Width	t_{CH}		20	$0.5 t_{CP}$		ns
	t_{CL}		20	$0.5 t_{CP}$		
RSYSCLK Period	t_{SP}	(Note 4)		648		ns
		(Note 5)		488		
RSYSCLK Pulse Width	t_{SH}		20	$0.5 t_{SP}$		ns
	t_{SL}		20	$0.5 t_{SP}$		ns
RSYNC Setup to RSYCLK Falling	t_{SU}		20			ns
RSYNC Pulse Width	t_{PW}		50			ns
RPOSI/RNEGI Setup to RDCLKI Falling	t_{SU}		20			ns
RPOSI/RNEGI Hold from RDCLKI Falling	t_{HD}		20			ns
RSYSCLK, RDCLKI Rise and Fall Times	t_R, t_F				22	ns
Delay RDCLKO to RPOSO, RNEGO Valid	t_{DD}				50	ns
Delay RCLKO to RSERO, RDATA, RSIG Valid	t_{D1}				50	ns
Delay RCLKO to RCHCLK, RSYNC, RCHBLK, RFSYNC	t_{D2}				50	ns
Delay RSYCLK to RSERO, RSIG Valid	t_{D3}				22	ns
Delay RSYCLK to RCHCLK, RCHBLK, RMSYNC, RSYNC	t_{D4}				22	ns

Note 1: Timing parameters in this table are guaranteed by design (GBD).

Note 2: Jitter attenuator enabled in the receive path.

Note 3: Jitter attenuator disabled or enabled in the transmit path.

Note 4: RSYCLK = 1.544MHz.

Note 5: RSYCLK = 2.048MHz.

Figure 13-13. Receive-Side Timing

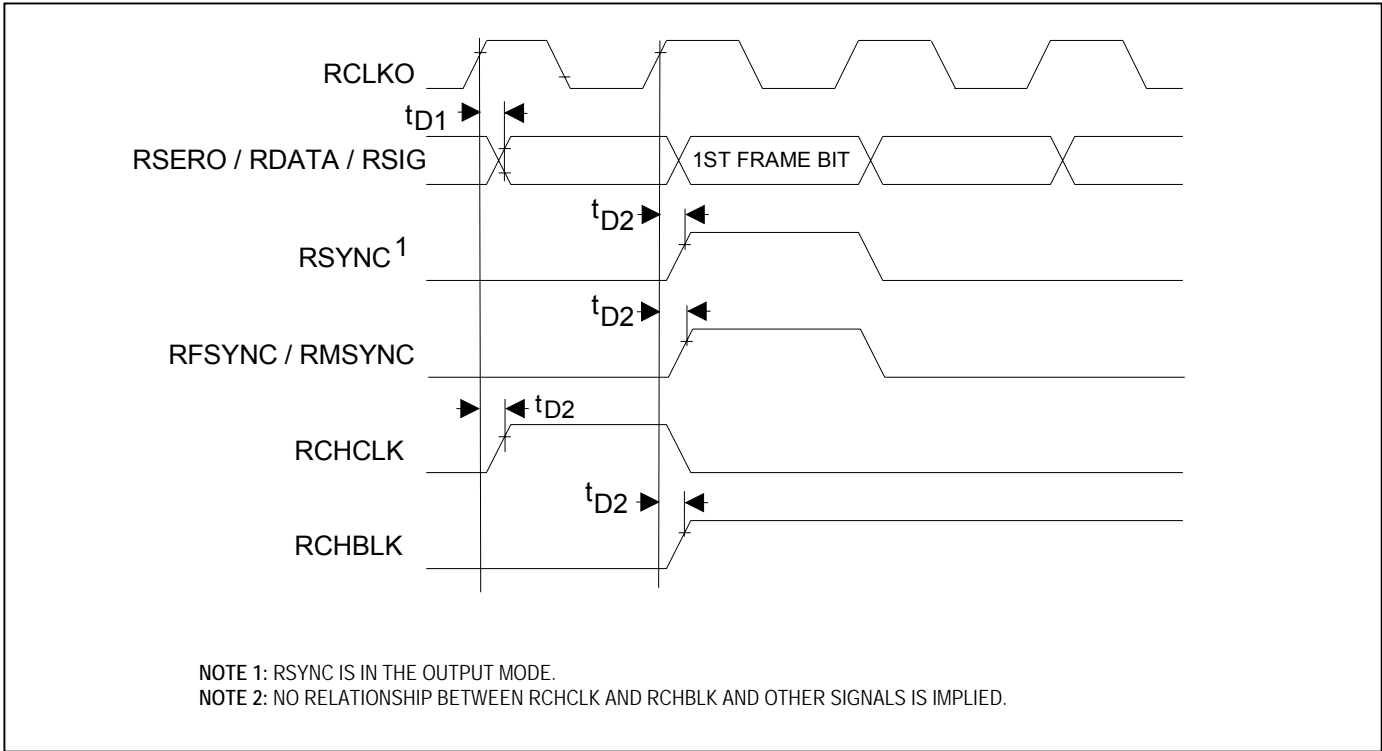

Figure 13-14. Receive-Side Timing, Elastic Store Enabled

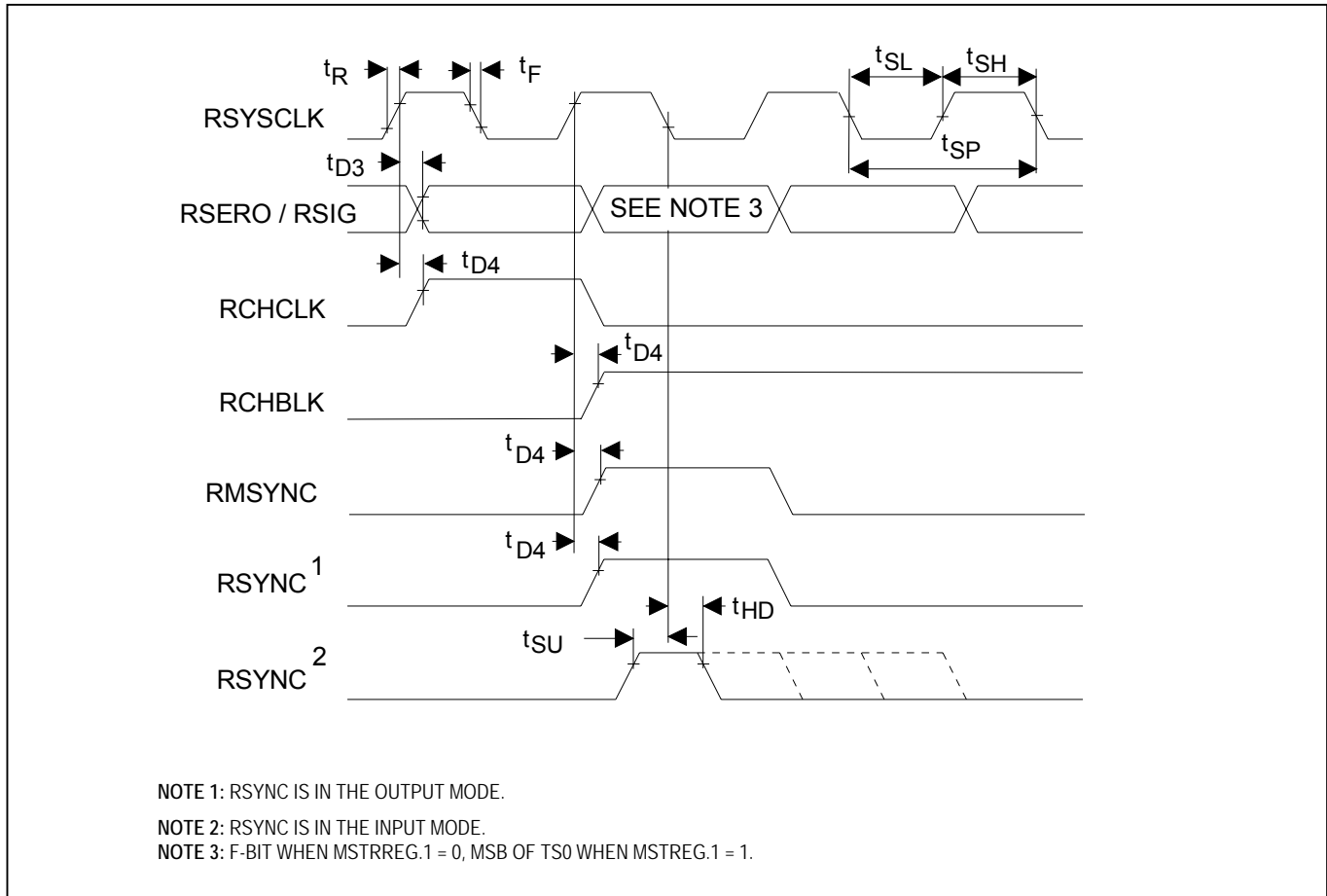
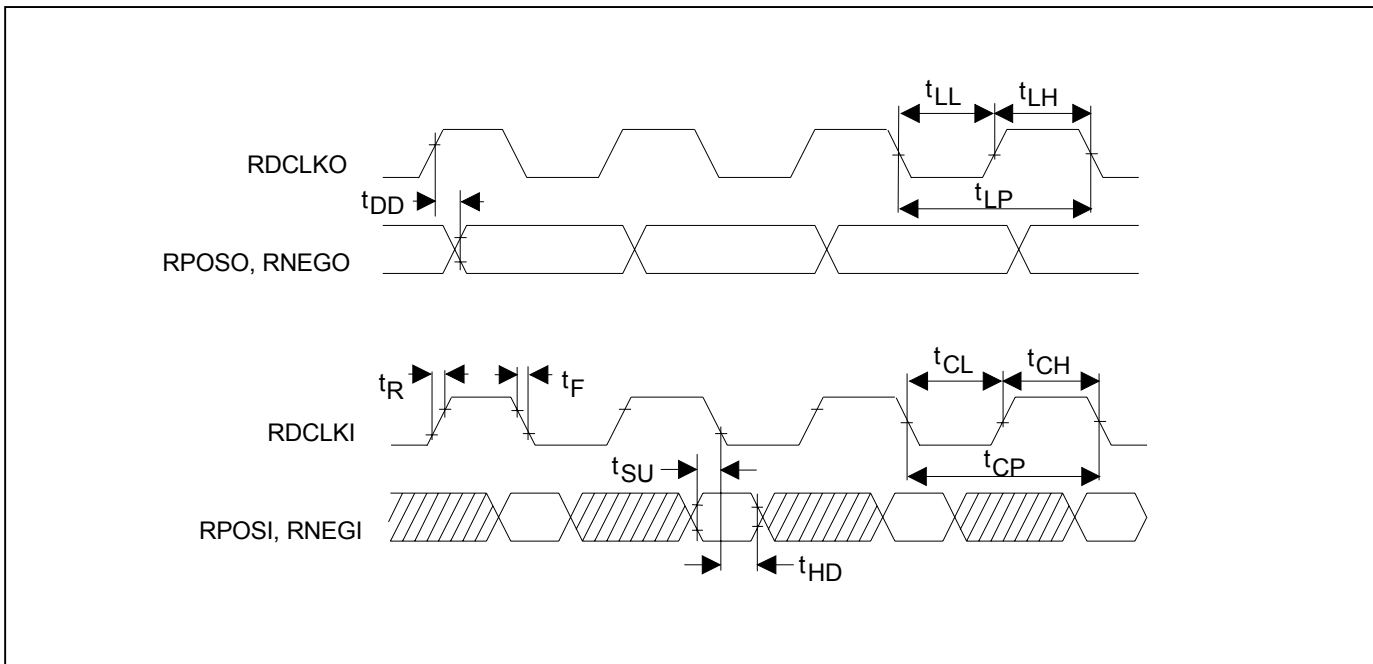

Figure 13-15. Receive Line Interface Timing



13.10 AC Characteristics: Backplane Clock Timing

Table 13-15. AC Characteristics: Backplane Clock Synthesis

($V_{DD} = 3.3V \pm 5\%$, $T_A = -40^\circ\text{C}$ to $+85^\circ\text{C}$.) (Note 1, ([Figure 13-16](#)))

PARAMETER	SYMBOL	CONDITIONS	MIN	TYP	MAX	UNITS
Delay RCLKO to BPCLK	t_{D1}				10	ns

Note: Timing parameters in this table are guaranteed by design (GBD).

Figure 13-16. Receive Timing Delay RCLKO to BPCLK

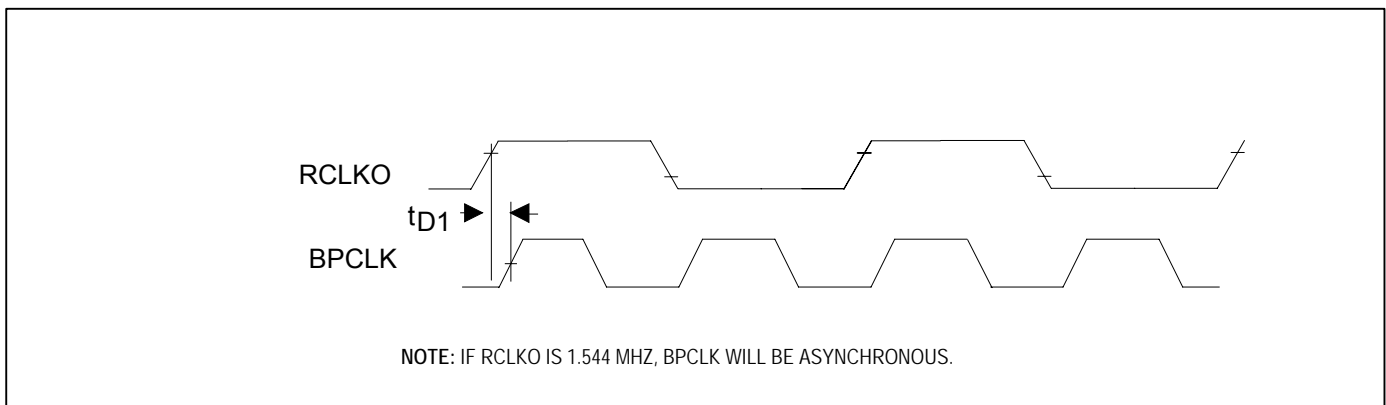

13.11 AC Characteristics: Transmit Side

Table 13-16. AC Characteristics: Transmit Side

($V_{DD} = 3.3V \pm 5\%$, $T_A = 0^\circ C$ to $+85^\circ C$.) (Note 1, [Figure 13-17](#), [Figure 13-18](#), and [Figure 13-19](#))

PARAMETER	SYMBOL	CONDITIONS	MIN	TYP (E1)	MAX	UNITS
TCLKT Period	t_{CP}			488 (E1)		ns
				648 (T1)		
TCLKT Pulse Width	t_{CH}		20	$0.5 t_{CP}$		ns
	t_{CL}		20	$0.5 t_{CP}$		
TDCLKI Period	t_{LP}			488 (E1)		ns
				648 (T1)		
TDCLKI Pulse Width	t_{LH}		20	$0.5 t_{LP}$		ns
	t_{LL}		20	$0.5 t_{LP}$		
TSYSCLK Period	t_{SP}	(Note 2)		648		ns
		(Note 3)		448		
TSYSCLK Pulse Width	t_{SP}		20	$0.5 t_{SP}$		ns
			20	$0.5 t_{SP}$		
TSYNC or TSSYNC Setup to TCLKT or TSYSCLK Falling	t_{SU}		20			ns
TSYNC or TSSYNC Pulse Width	t_{PW}		50			ns
TSERI, TSIG, TDATA, TPOSI, TNEGI Setup to TCLKT, TSYSCLK, TDCLKI Falling	t_{SU}		20			ns
TSERI, TSIG, TDATA Hold from TCLKT or TSYSCLK Falling	t_{HD}		20			ns
TPOSI, TNEGI Hold from TDCLKI Falling	t_{HD}		20			ns
TCLKT, TDCLKI or TSYSCLK Rise and Fall Times	t_R, t_F				25	ns
Delay TCLKO to TPOSO, TNEGO Valid	t_{DD}				50	ns
Delay TCLKT to TESO, UT-UTDO Valid	t_{D1}				50	ns
Delay TCLKT to TCHBLK, TCHCLK, TSYNC	t_{D2}				50	ns
Delay TSYSCLK to TCHCLK, TCHBLK	t_{D3}				22	ns

Note 1: Timing parameters in this table are guaranteed by design (GBD).

Note 2: TSYSCLK = 1.544MHz.

Note 3: TSYSCLK = 2.048MHz.

Figure 13-17. Transmit-Side Timing

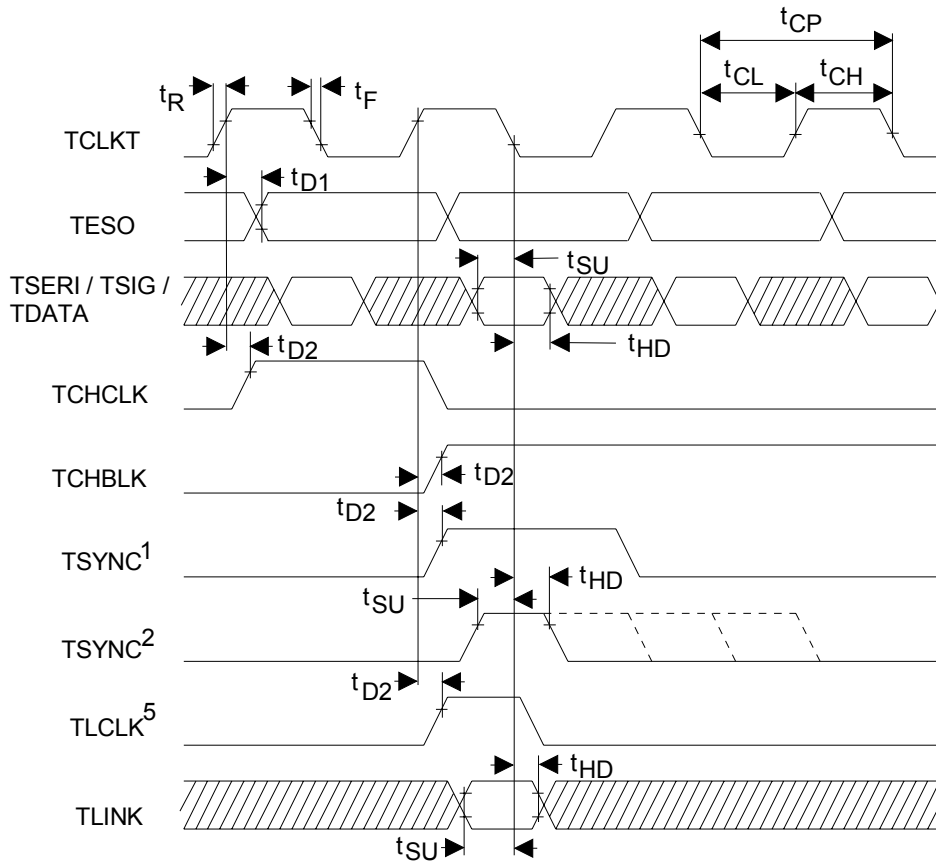

NOTE 1: TSYNC IS IN THE OUTPUT MODE (IOCR1.1 = 1).

NOTE 2: TSYNC IS IN THE INPUT MODE (IOCR1.1 = 0).

NOTE 3: TSERI IS SAMPLED ON THE FALLING EDGE OF TCLKT WHEN THE TRANSMIT-SIDE ELASTIC STORE IS DISABLED.

NOTE 4: TCHCLK AND TCHBLK ARE SYNCHRONOUS WITH TCLKT WHEN THE TRANSMIT-SIDE ELASTIC STORE IS DISABLED.

Figure 13-18. Transmit-Side Timing, Elastic Store Enabled

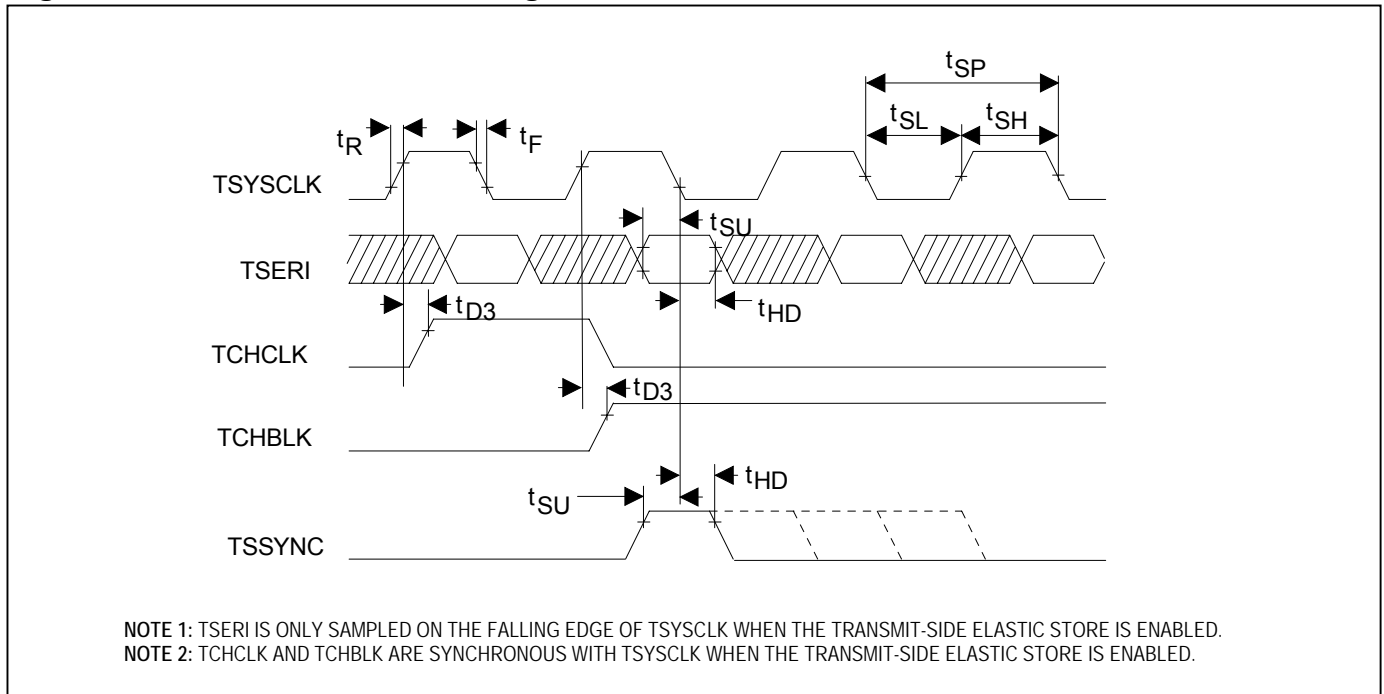
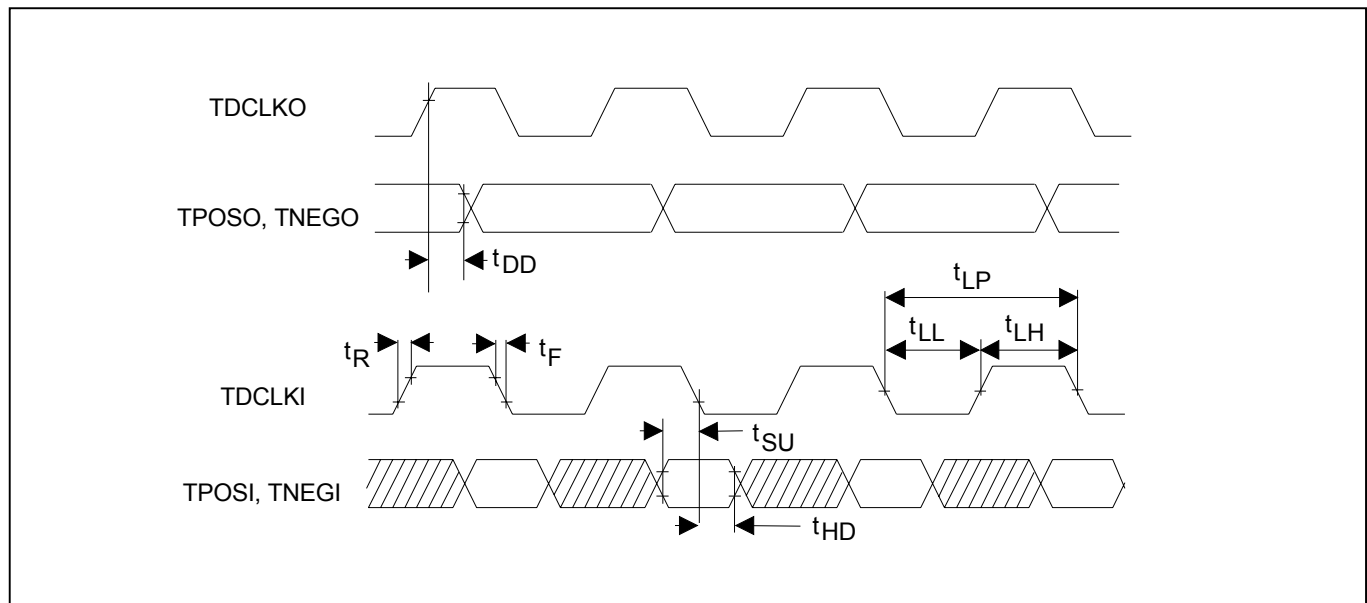

Figure 13-19. Transmit Line Interface Timing



13.12 JTAG Interface Timing

Table 13-17. JTAG Interface Timing

(VDD3.3 = 3.3V \pm 5%, VDD1.8 = 1.8V \pm 5%, T_i = -40°C to +85°C.) (Note 1, [Figure 13-20](#))

PARAMETER	SYMBOL	MIN	TYP	MAX	UNITS
JTCLK Clock Period	t1		1000		ns
JTCLK Clock High:Low Time (Note 2)	t2 : t3	50	500		ns
JTCLK to JTDI, JTMS Setup Time	t4	2			ns
JTCLK to JTDI, JTMS Hold Time	t5	2			ns
JTCLK to JTDO Delay	t6	2		50	ns
JTCLK to JTDO HIZ Delay	t7	2		50	ns
$\overline{\text{JTRST}}$ Width Low Time	t8	100			ns

Note 1: Timing parameters in this table are guaranteed by design (GBD).

Note 2: Clock can be stopped high or low

Figure 13-20. JTAG Interface Timing Diagram

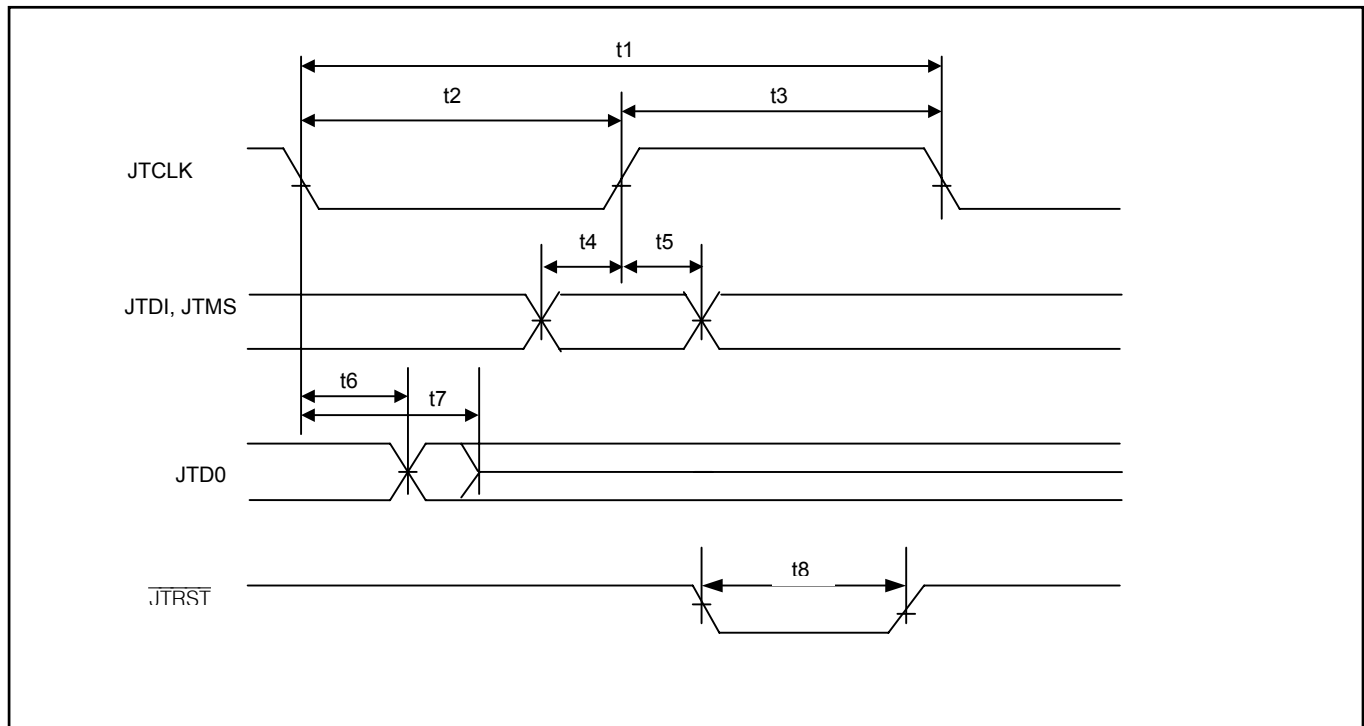

14 JTAG INFORMATION

The DS33R11 contains two JTAG ports. Port 1 is for the Ethernet Mapper, and Port 2 is for the T1/E1/J1 Transceiver. Because of this, this device requires special consideration during JTAG test design. For more information on performing JTAG testing using this device, email telecom.support@dalsemi.com.

The device supports the standard instruction codes SAMPLE:PRELOAD, BYPASS, and EXTEST. Optional public instructions included are HIGHZ, CLAMP, and IDCODE. See Table 20-1. The DS26521 contains the following as required by IEEE 1149.1 Standard Test Access Port and Boundary Scan Architecture.

Test Access Port (TAP)
TAP Controller
Instruction Register

Bypass Register
Boundary Scan Register
Device Identification Register

The Test Access Port has the necessary interface pins: $\overline{\text{JTRST}}$, JTCLK, JTMS, JTDI, and JTDO. See the pin descriptions for details. Refer to IEEE 1149.1-1990, IEEE 1149.1a-1993, and IEEE 1149.1b-1994 for details about the Boundary Scan Architecture and the Test Access Port.

Figure 14-1. JTAG Functional Block Diagram

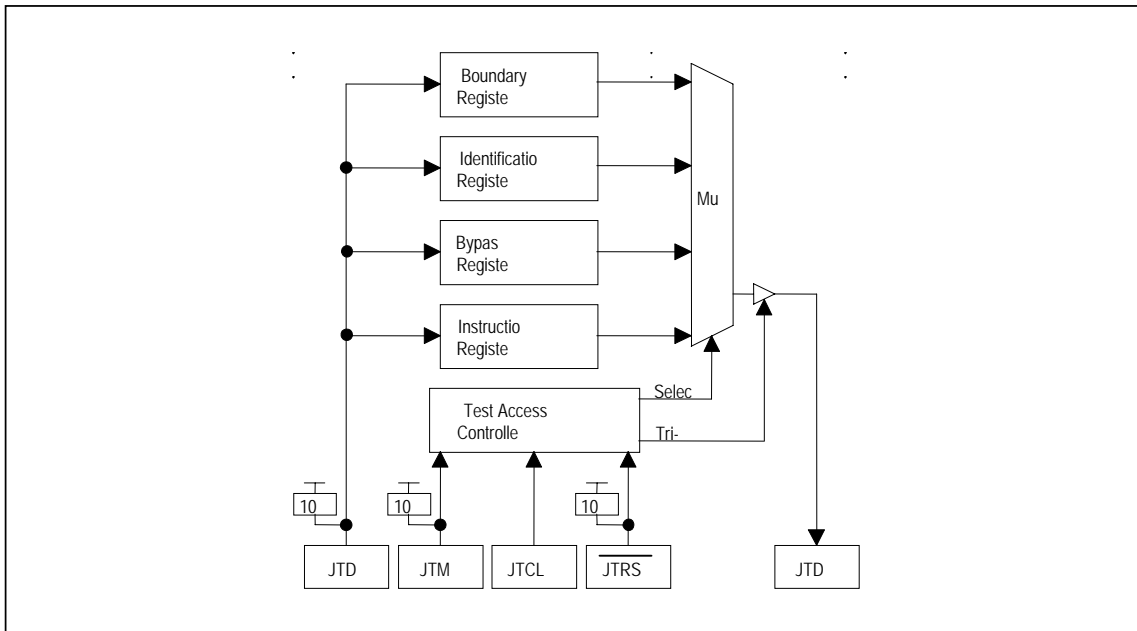

14.1 JTAG TAP Controller State Machine Description

This section covers the details on the operation of the Test Access Port (TAP) Controller State Machine. The TAP controller is a finite state machine that responds to the logic level at JTMS on the rising edge of JTCLK.

TAP Controller State Machine

The TAP controller is a finite state machine that responds to the logic level at JTMS on the rising edge of JTCLK. See [Figure 14-2](#) for a diagram of the state machine operation.

Test-Logic-Reset

Upon power up, the TAP Controller is in the Test-Logic-Reset state. The Instruction register will contain the IDCODE instruction. All system logic of the device will operate normally.

Run-Test-Idle

The Run-Test-Idle is used between scan operations or during specific tests. The Instruction register and test registers will remain idle.

Select-DR-Scan

All test registers retain their previous state. With JTMS LOW, a rising edge of JTCLK moves the controller into the Capture-DR state and will initiate a scan sequence. JTMS HIGH during a rising edge on JTCLK moves the controller to the Select-IR-Scan state.

Capture-DR

Data may be parallel-loaded into the test data registers selected by the current instruction. If the instruction does not call for a parallel load or the selected register does not allow parallel loads, the test register will remain at its current value. On the rising edge of JTCLK, the controller will go to the Shift-DR state if JTMS is LOW or it will go to the Exit1-DR state if JTMS is HIGH.

Shift-DR

The test data register selected by the current instruction is connected between JTDI and JTDO and will shift data one stage towards its serial output on each rising edge of JTCLK. If a test register selected by the current instruction is not placed in the serial path, it will maintain its previous state.

Exit1-DR

While in this state, a rising edge on JTCLK will put the controller in the Update-DR state, which terminates the scanning process, if JTMS is HIGH. A rising edge on JTCLK with JTMS LOW will put the controller in the Pause-DR state.

Pause-DR

Shifting of the test registers is halted while in this state. All test registers selected by the current instruction will retain their previous state. The controller will remain in this state while JTMS is LOW. A rising edge on JTCLK with JTMS HIGH will put the controller in the Exit2-DR state.

Exit2-DR

A rising edge on JTCLK with JTMS HIGH while in this state will put the controller in the Update-DR state and terminate the scanning process. A rising edge on JTCLK with JTMS LOW will enter the Shift-DR state.

Update-DR

A falling edge on JTCLK while in the Update-DR state will latch the data from the shift register path of the test registers into the data output latches. This prevents changes at the parallel output due to changes in the shift register.

Select-IR-Scan

All test registers retain their previous state. The instruction register will remain unchanged during this state. With JTMS LOW, a rising edge on JTCLK moves the controller into the Capture-IR state and will initiate a scan sequence for the instruction register. JTMS HIGH during a rising edge on JTCLK puts the controller back into the Test-Logic-Reset state.

Capture-IR

The Capture-IR state is used to load the shift register in the instruction register with a fixed value. This value is loaded on the rising edge of JTCLK. If JTMS is HIGH on the rising edge of JTCLK, the controller will enter the Exit1-IR state. If JTMS is LOW on the rising edge of JTCLK, the controller will enter the Shift-IR state.

Shift-IR

In this state, the shift register in the instruction register is connected between JTDI and JTDO and shifts data one stage for every rising edge of JTCLK towards the serial output. The parallel register, as well as all test registers, remains at their previous states. A rising edge on JTCLK with JTMS HIGH will move the controller to the Exit1-IR state. A rising edge on JTCLK with JTMS LOW will keep the controller in the Shift-IR state while moving data one stage through the instruction shift register.

Exit1-IR

A rising edge on JTCLK with JTMS LOW will put the controller in the Pause-IR state. If JTMS is HIGH on the rising edge of JTCLK, the controller will enter the Update-IR state and terminate the scanning process.

Pause-IR

Shifting of the instruction shift register is halted temporarily. With JTMS HIGH, a rising edge on JTCLK will put the controller in the Exit2-IR state. The controller will remain in the Pause-IR state if JTMS is LOW during a rising edge on JTCLK.

Exit2-IR

A rising edge on JTCLK with JTMS LOW will put the controller in the Update-IR state. The controller will loop back to Shift-IR if JTMS is HIGH during a rising edge of JTCLK in this state.

Update-IR

The instruction code shifted into the instruction shift register is latched into the parallel output on the falling edge of JTCLK as the controller enters this state. Once latched, this instruction becomes the current instruction. A rising edge on JTCLK with JTMS held low will put the controller in the Run-Test-Idle state. With JTMS HIGH, the controller will enter the Select-DR-Scan state.

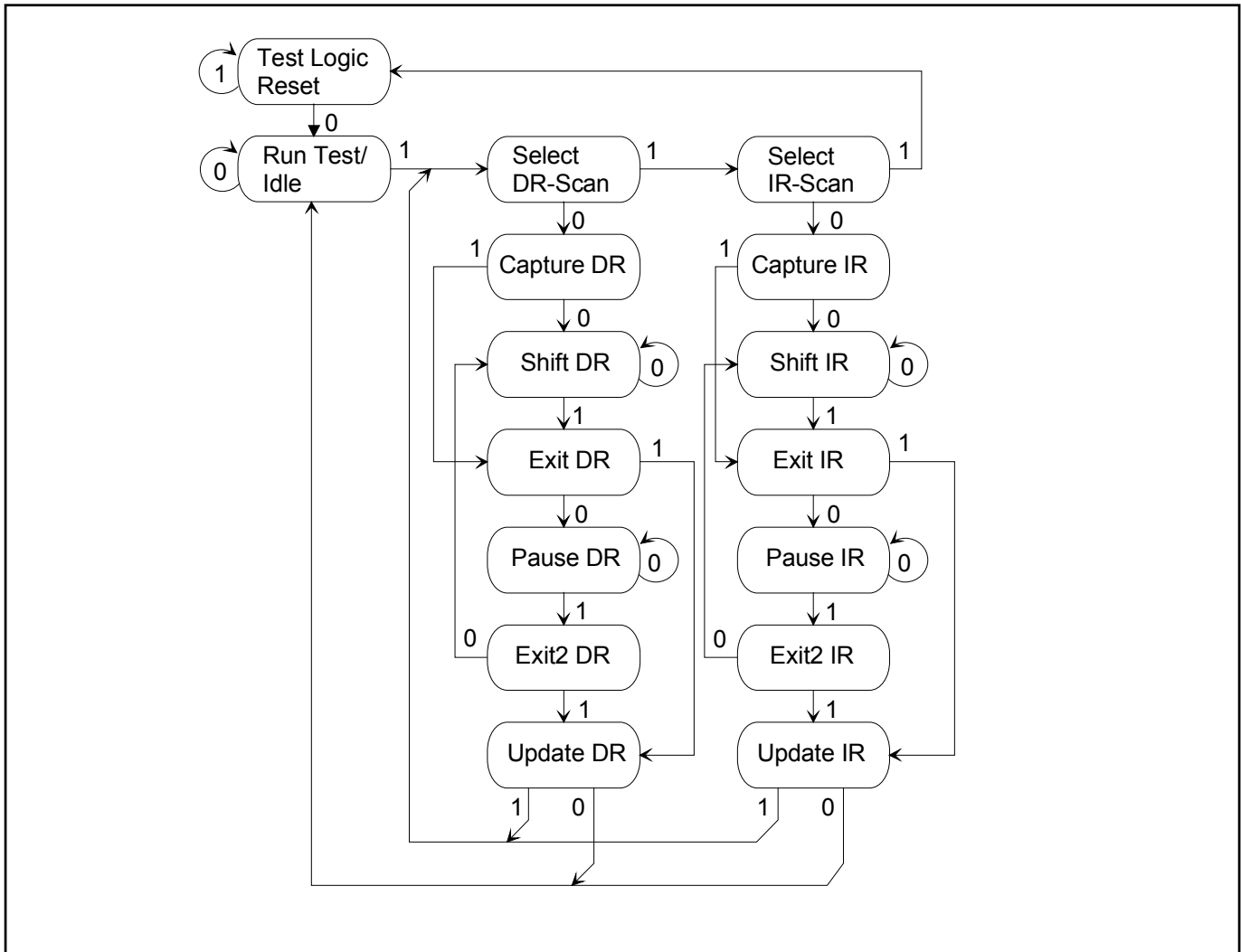
Figure 14-2. TAP Controller State Diagram

14.2 Instruction Register

The instruction register contains a shift register as well as a latched parallel output and is 3 bits in length. When the TAP controller enters the Shift-IR state, the instruction shift register is connected between JTDI and JTDO. While in the Shift-IR state, a rising edge on JTCLK with JTMS LOW will shift the data one stage towards the serial output at JTDO. A rising edge on JTCLK in the Exit1-IR state or the Exit2-IR state with JTMS HIGH will move the controller to the Update-IR state. The falling edge of that same JTCLK will latch the data in the instruction shift register to the instruction parallel output. Instructions supported by the DS26521 and its respective operational binary codes are shown in [Table 14-1](#).

Table 14-1. Instruction Codes for IEEE 1149.1 Architecture

INSTRUCTION	SELECTED REGISTER	INSTRUCTION CODES
SAMPLE:PRELOAD	Boundary Scan	010
BYPASS	Bypass	111
EXTEST	Boundary Scan	000
CLAMP	Bypass	011
HIGHZ	Bypass	100
IDCODE	Device Identification	001

SAMPLE:PRELOAD

This is a mandatory instruction for the IEEE 1149.1 specification. This instruction supports two functions. The digital I/Os of the device can be sampled at the boundary scan register without interfering with the normal operation of the device by using the Capture-DR state. SAMPLE:PRELOAD also allows the device to shift data into the boundary scan register via JTDI using the Shift-DR state.

BYPASS

When the BYPASS instruction is latched into the parallel instruction register, JTDI connects to JTDO through the one-bit bypass test register. This allows data to pass from JTDI to JTDO not affecting the device's normal operation.

EXTEST

This allows testing of all interconnections to the device. When the EXTEST instruction is latched in the instruction register, the following actions occur. Once enabled via the Update-IR state, the parallel outputs of all digital output pins are driven. The boundary scan register is connected between JTDI and JTDO. The Capture-DR will sample all digital inputs into the boundary scan register.

CLAMP

All digital outputs of the device will output data from the boundary scan parallel output while connecting the bypass register between JTDI and JTDO. The outputs will not change during the CLAMP instruction.

HIGHZ

All digital outputs of the device are placed in a high-impedance state. The BYPASS register is connected between JTDI and JTDO.

IDCODE

When the IDCODE instruction is latched into the parallel instruction register, the identification test register is selected. The device identification code is loaded into the identification register on the rising edge of JTCLK following entry into the Capture-DR state. Shift-DR can be used to shift the identification code out serially via JTDO. During Test-Logic-Reset, the identification code is forced into the instruction register's parallel output. The ID code will always have a '1' in the LSB position. The next 11 bits identify the manufacturer's JEDEC number and number of continuation bytes followed by 16 bits for the device and 4 bits for the version.

14.3 JTAG ID Codes

Table 14-2. ID Code Structure

DEVICE	REVISION ID[31:28]	DEVICE CODE ID[27:12]	MANUFACTURER'S CODE ID[11:1]	REQUIRED ID[0]
Ethernet Mapper	0000	0000 0000 0110 0001	000 1010 0001	1
T1/E1/J1 Transceiver	0000	0000 0000 0001 0000	000 1010 0001	1

14.4 Test Registers

IEEE 1149.1 requires a minimum of two test registers: the bypass register and the boundary scan register. An optional test register has been included with the DS26521 design. This test register is the identification register and is used in conjunction with the IDCODE instruction and the Test-Logic-Reset state of the TAP controller.

14.4.1 Boundary Scan Register

This register contains both a shift register path and a latched parallel output for all control cells and digital I/O cells and is n bits in length.

14.4.2 Bypass Register

This is a single one-bit shift register used in conjunction with the BYPASS, CLAMP, and HIGHZ instructions, which provides a short path between JTDI and JTDO.

14.4.3 Identification Register

The identification register contains a 32-bit shift register and a 32-bit latched parallel output. This register is selected during the IDCODE instruction and when the TAP controller is in the Test-Logic-Reset state.

14.5 JTAG Functional Timing

This functional timing for the JTAG circuits shows:

- The JTAG controller starting from reset state.
- Shifting out the first 4 LSB bits of the IDCODE.
- Shifting in the BYPASS instruction (111) while shifting out the mandatory X01 pattern.
- Shifting the TDI pin to the TDO pin through the bypass shift register.
- An asynchronous reset occurs while shifting.

Figure 14-3. JTAG Functional Timing

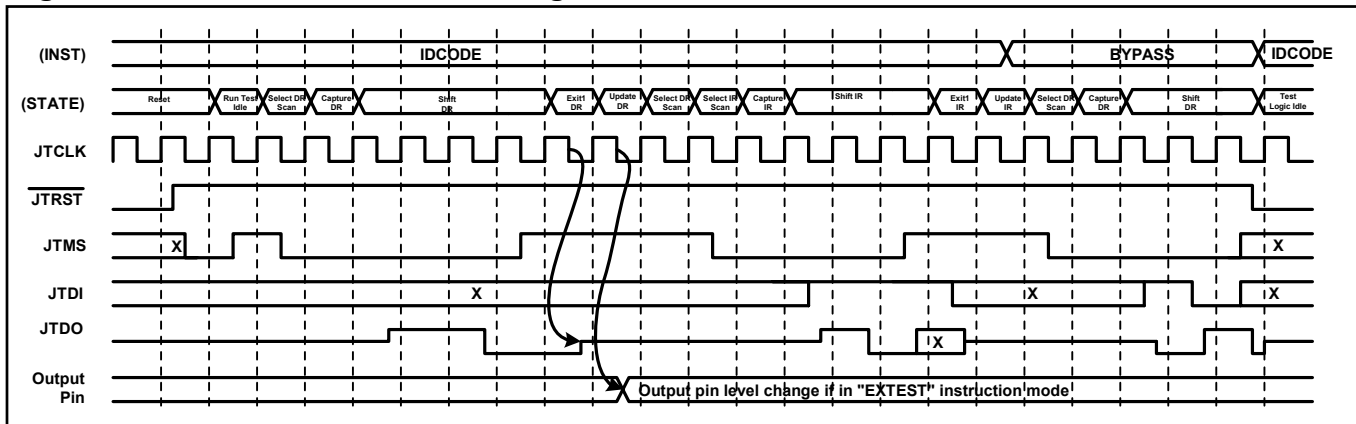

15 PACKAGE INFORMATION

(The package drawing(s) in this data sheet may not reflect the most current specifications. The package number provided for each package is a link to the latest package outline information.)

15.1 256-Ball BGA (27mm x 27mm) ([56-G6004-001](#))

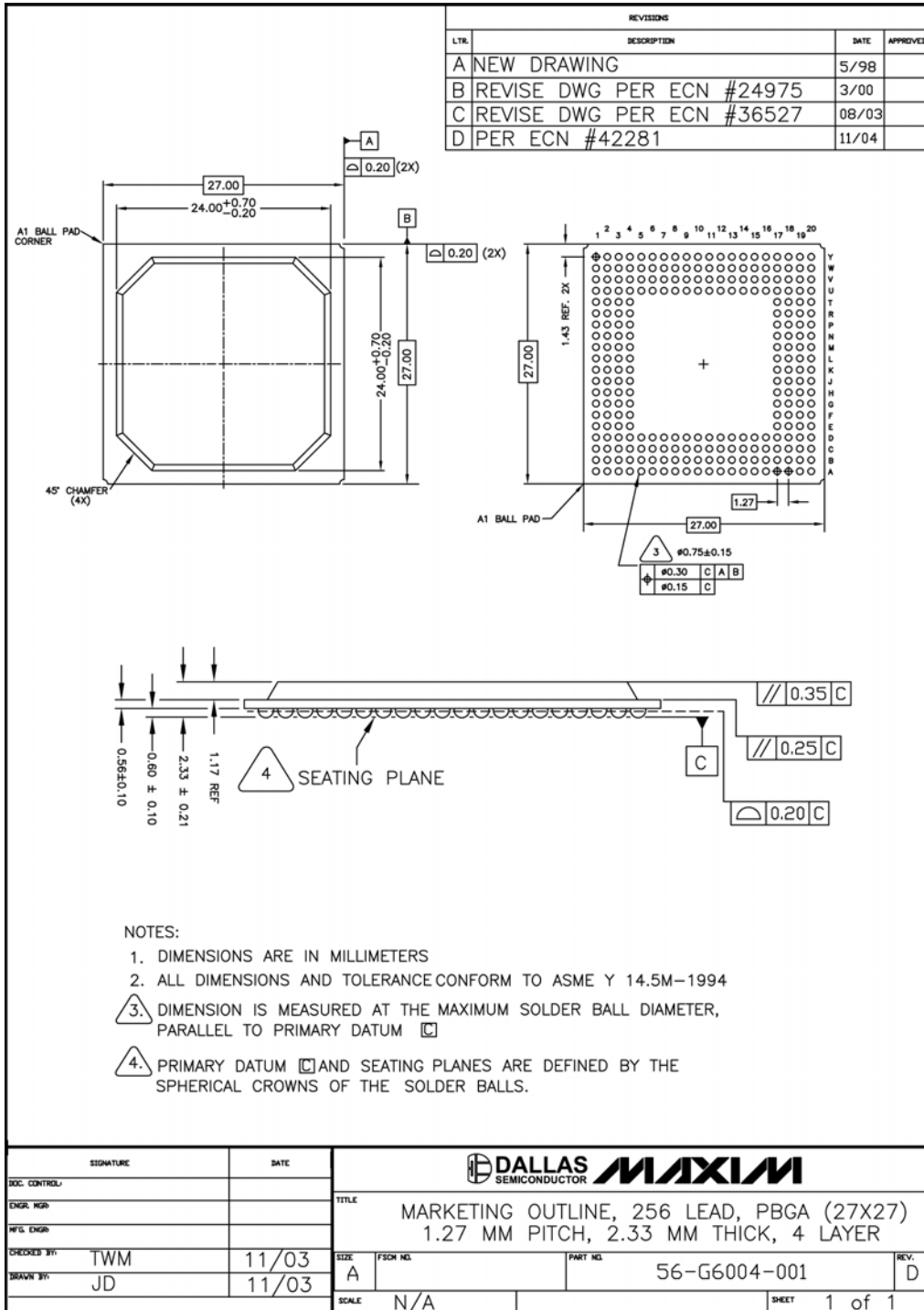

16 DOCUMENT REVISION HISTORY

REVISION	DESCRIPTION
072105	New product release.
030807	<p>(Page 28) Corrected pin description of REF_CLK.</p> <p>(Page 28) Clarified text regarding use of REF_CLKO in DCE and RMII modes.</p> <p>(Page 29) Corrected pin description of MDC.</p> <p>(Page 43) In Section 9.1, removed from third bullet the sentence “The user can utilize the built-in REF_CLKO output clock to drive this input.” Also removed from the fifth bullet the sentence “This output clock can be used as an input to REF_CLK, allowing the user to have one less oscillator for the system.”</p> <p>(Page 45) In Section 9.1.1, updated the section to show that in DCE and RMII operating modes, the REF_CLKO signal should not be used to provide an input to REF_CLK, due to the reset requirements in these operating modes.</p> <p>(Page 46) In Section 9.2, corrected low-power mode information.</p> <p>(Page 56) In Section 9.14, removed the following sentence from the first paragraph: “The REF_CLKO output can be used to source the REF_CLK input.”</p> <p>(Page 68) In Section 9.19, clarified X.86 mode synchronization.</p> <p>(Page 123) In Table 11-7, corrected SU.MACCR register map.</p> <p>(Page 173) Corrected SU.GCR.H10S bit definition.</p> <p>(Page 183) Corrected default value for RMPS (bit 0) in the SU.RMFSRL register definition.</p> <p>(Page 183) Corrected the SU.RQLT and SU.RQHT default values to zero.</p> <p>(Page 186) Corrected SU.MACCR.PM and SU.MACCR.PAM bit definitions.</p> <p>(Page 319) In Table 13-10, added TCLKE to TBSYNC Setup Time Minimum of 3.5ns.</p> <p>(Page 334) Added a note regarding the special considerations required for dual JTAG controllers.</p>