

Click [here](#) to ask about the production status of specific part numbers.

MAX11410 Breakout Board

24-Bit 1.9ksps Delta-Sigma ADC

General Description

Analog-to-digital converters (ADCs) provide accurate measurement and conversion of signals to digital format for sensing in many electronic applications such as industrial, medical, and sensor systems. The MAX11410 is a high speed, 24-bit delta-sigma ADC. Development with delta-sigma ADCs involves expertise in analog systems, power supplies, digital interfaces, and firmware. Now, enter the MAX11410 breakout board to accelerate the development process.

The MAX11410 breakout board provides for rapid prototyping and development with the MAX11410 (a 24-bit, 1.9ksps, delta-sigma ADC). It interfaces to any Arduino™-compatible or Mbed™-compatible platform system with expansion ports configurable for SPI communication. Additionally, the MAX11410 breakout board works with systems that have a Pmod™ connection, a 2x6 right-angle header at board edge (compatible with Digilentinc.com Pmod interface spec) interface type 2A (expanded SPI) on 2x6 header at board edge. The MAX11410 breakout board also comes with schematics, design files, and firmware for immediate use and forking to future projects.

The board interfaces to SPI with logic levels in the 1.71V to 5.5V range.

The board comes with MAX11410ATI+ installed.

[Ordering Information](#) appears at end of data sheet.

Example firmware is provided for Arduino and system boards.

Tested with:

- MAX32625MBED# <https://os.mbed.com/platforms/MAX32625MBED/>
- MAX32600MBED# <https://os.mbed.com/platforms/MAX32600MBED/>
- STM32F446 Nucleo-64 <https://os.mbed.com/platforms/ST-Nucleo-F446RE/>
- Arduino UNO (rev 3) <https://store.arduino.cc/usa/arduino-uno-rev3/>
- Adafruit Metro 328 Arduino compatible (USB micro B) <https://www.adafruit.com/product/50>
- Arduino Pro Mini 3.3V/8MHz <https://store.arduino.cc/usa/arduino-pro-mini/>

Board Photo

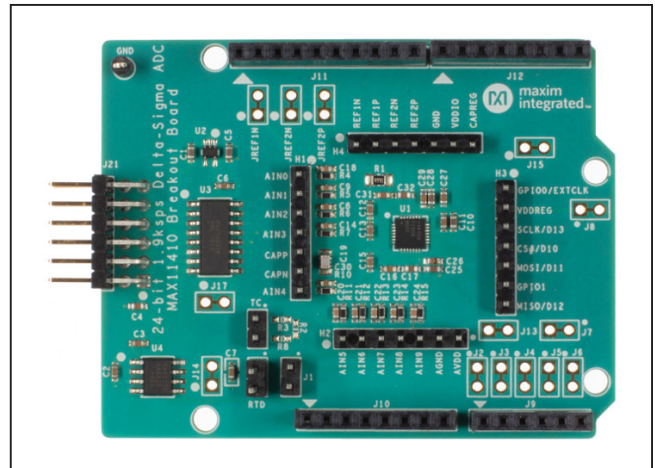

Arduino is a trademark of Arduino AG.

Mbed is a registered trademark and service mark of Arm Limited.

Pmod is a trademark of Diligent, Inc.



Procedure for Mbed: Simplified Hello World

The Simplified Hello World program is a small example program that can be changed by modifying the Hello_MAX11410.cpp source code and repeating the compile-build-upload cycle, providing straightforward code for easy adoption.

The breakout board is fully assembled and tested.

The first time the board is used, the MAX11410 breakout board firmware must be loaded into the MAX32625MBED or equivalent platform board. This firmware is stored on the MAX32625MBED board and remains after the board is powered off.

When the board is plugged into the USB for the first time, the computer might need about a minute to install its device drivers.

Use the following steps to verify board operation:

- 1) Connect the MAX11410 breakout board to the MAX32625MBED or equivalent Mbed platform board using the standard pinout.
- 2) Connect a USB cable from computer to MAX32625MBED board HDK USB port. (Windows can require some time to install its device driver.) Expect the system to automatically mount the board as a new USB drive named MBED or DAPLINK or something similar. This is a special-purpose drive: firmware loads into the board by copying the compiled binary into the board's drive. Do not write any other files to this drive.
- 3) Open the board's USB device folder and double click on its MBED.HTML file. On the board page, click **Add to your Mbed Compiler**. This adds the Mbed board to the online compiler as a compilation target. Refer to <https://os.mbed.com/docs/mbed-os/v5.13/quick-start/index.html> for more detailed instructions on using the online compiler.
- 4) In a web browser, navigate to https://os.mbed.com/teams/MaximIntegrated/code/MAX11410BOB_24bit_ADC/ and click **Import into Compiler**. The Mbed online IDE window opens and prompts to import program. Click the **Import** button to complete the import.
- 5) Compile the program. When complete, the online Mbed IDE downloads the firmware file to the local downloads folder.

- 6) Locate the newly built firmware file (MAX11410BOB_24bit_ADC.MAX32625MBED.bin) and copy the file to the board's Mbed drive. (The names might not match exactly if using a platform other than MAX32625MBED or if there is already a file with that name.) If a warning dialog appears asking to move this file without its properties, click **Yes**. After file copying is complete, press and release the board's **RESET** button to start the firmware. Connect input voltages to AIN inputs. Note if nothing is connected to the analog inputs, the value can float to an unspecified, arbitrary value.
- 7) The program behavior can be changed by modifying the Hello_MAX11410.cpp source code and repeating the compile-build-upload cycle from step 4.
- 8) Optionally, discard local changes and reset to the latest published firmware version as follows: Bring up the project **Revision** tab and right-click on the line that says default tip. In the popup context menu, select switch working copy to this revision. A warning appears indicating that there are uncommitted local changes in the working tree. Click **Discard**, and all of the local files are reset to the published version.

Procedure for Mbed: Serial Tester

The Serial Tester program is an interactive, menu-driven test program which is controlled through a serial communications port, using a terminal emulator, supporting quick discovery and evaluation of device features for testing functionality.

The breakout board is fully assembled and tested.

The first time the board is used, the MAX11410 breakout board firmware must be loaded into the MAX32625MBED, or equivalent platform board. This firmware is stored on the MAX32625MBED board and remains after the board is powered off.

The serial tester firmware uses a USB serial port to communicate.

When the board is plugged into the USB for the first time, the computer might need about a minute to install its device drivers.

Windows is a registered trademark and registered service mark of Microsoft Corp.

Use the following steps to verify board operation:

- 1) Connect the MAX11410 breakout board to the MAX32625MBED or equivalent Mbed platform board using the standard pinout.
- 2) Connect a USB cable from computer to MAX32625MBED board HDK USB port. (Windows can require some time to install its device driver.) Expect the system to automatically mount the board as a new USB drive named MBED or DAPLINK or something similar. This is a special-purpose drive: firmware loads into the board by copying the compiled binary into the board's drive. Do not write any other files to this drive.
- 3) Open the board's USB device folder and double click on its Mbed.HTML file. On the board page, click **Add to your Mbed Compiler**. This adds the Mbed board to the online compiler as a compilation target. Refer to <https://os.mbed.com/docs/mbed-os/v5.13/quick-start/index.html> for more detailed instructions on using the online compiler.
- 4) In a web browser, navigate to https://os.mbed.com/teams/MaximIntegrated/code/MAX11410BOB_Serial_Tester/ and click **Import into Compiler**. The Mbed online IDE window opens and prompts to import program. Click the **Import** button to complete the import.
- 5) Compile the program. When complete, the online Mbed IDE downloads the firmware file to the local downloads folder.
- 6) Locate the newly built firmware file MAX11410BOB_Serial_Tester.MAX32625MBED.bin and copy the file to the board's MBED drive. (The names might not match exactly if using a platform other than MAX-32625MBED, or if there is already a file with that name.) If a warning dialog appears asking to move this file without its properties, click **Yes**.
- 7) Connect another, or the existing USB cable from computer to the MAX32625MBED board DEV USB port. Expect the LEDs in the lower right corner should flash briefly and then remain lit.
- 8) Locate the newly arrived USB serial device COM port and use a serial terminal emulator (such as teraterm, realterm, picocom, minicom, or equivalent). Baud rate is 9600.

Procedure for Arduino: Simplified Hello World

The Simplified Hello World program is a small example program which can be changed by modifying the Hello_MAX11410.cpp source code and repeating the compile-build-upload cycle, providing straightforward code for easy adoption.

The breakout board is fully assembled and tested.

Note if used with classic Arduino UNO which has full-sized USB type B connector, ensure that the shield of the USB connector does not contact the underside of the breakout board/Arduino shield.

The first time the board is used, the MAX11410 breakout board firmware must be loaded into the Arduino board. This firmware is stored on the Arduino board and remains after the board is powered off.

The firmware uses a USB serial port to communicate.

When the board is plugged into the USB for the first time, the computer might need about a minute to install its device drivers.

Use the following steps to verify board operation:

- 1) Connect the MAX11410 breakout board to the Arduino board using the standard pinout.
- 2) Connect a USB cable from computer to Arduino board USB port. (Windows can require some time to install its device driver.)
- 3) In a web browser, navigate to <https://create.arduino.cc/editor/whismanoid/88dd946b-d8be-45ef-b922-aa1dfd13d1af/preview> and click **Add to my Sketchbook**.
- 4) Connect the USB cable to the Arduino hardware. If this is the first time using Arduino Create online, a prompt may appear to install the Arduino Create Agent to connect with the hardware.
- 5) Compile the program with the **Upload** and **Save** button.
- 6) Connect input voltages to AIN inputs. Note if nothing is connected to the analog inputs, the value can float to an unspecified, arbitrary value.
- 7) The program behavior can be changed by modifying the Hello_MAX11410.cpp source code and repeating the compile-build-upload cycle.

Procedure for Arduino: Serial Tester

The Serial Tester program is an interactive, menu-driven test program which is controlled through a serial communications port, using a terminal emulator, supporting quick discovery, and evaluation of device features for testing functionality.

The breakout board is fully assembled and tested.

Note if used with classic Arduino UNO which has full-sized USB type B connector, ensure that the shield of the USB connector does not contact the underside of the breakout board/Arduino shield.

The first time the board is used, the MAX11410 breakout board firmware must be loaded into the Arduino board. This firmware is stored on the Arduino board and remains after the board is powered off.

The firmware uses a USB serial port to communicate.

When the board is plugged into the USB for the first time, the computer might need about a minute to install its device drivers.

Use the following steps to verify board operation:

- 1) Connect the MAX11410 breakout board to the Arduino board using the standard pinout.
- 2) Connect a USB cable from computer to Arduino board USB port. (Windows may require some time to install its device driver.)
- 3) In a web browser, navigate to <https://create.arduino.cc/editor/whismanoid/4a982b95-bb92-4ca3-99f8-3029b693a119/preview> and click **Add to my Sketchbook**.
- 4) Connect the USB cable to the Arduino hardware. If this is the first time using Arduino Create online, a prompt may appear to install the Arduino Create Agent to connect with the hardware.
- 5) Compile the program with the **Upload** and **Save** button.
- 6) Locate the newly arrived USB serial device COM port and use a serial terminal emulator (such as teraterm, realterm, picocom, minicom, or equivalent). Baud rate is 9600.

Sending Commands with a Serial Console

A serial terminal emulator software (such as teraterm, realterm, putty, picocom, minicom, or equivalent) must be installed to communicate with the example firmware. Various terminal programs connect in various ways and have different user interfaces, but they all share a common set of basic features:

- Connecting to a specific serial port device by name, such as COM4 or /dev/ttyACM0
- Settings such as baud rate 9600, 8 bits/No parity/1 Stop bit, no flow control
- Typing at the keyboard transmits to the firmware through the serial port
- Messages received from the firmware are displayed on the screen
- A special keyboard command or menu item exits the terminal program

Refer to <https://os.mbed.com/handbook/Terminals> for more details.

More resources:

- <https://learn.sparkfun.com/tutorials/terminal-basics/tera-term-windows>
- <https://learn.sparkfun.com/tutorials/terminal-basics/real-term-windows>
- <https://learn.sparkfun.com/tutorials/terminal-basics/yat---yet-another-terminal-windows>
- <https://learn.sparkfun.com/tutorials/terminal-basics/coolterm-windows-mac-linux>
- <https://learn.adafruit.com/windows-tools-for-the-electrical-engineer/serial-terminal>
- <https://www.putty.org/>

In Windows, install a terminal emulator such as teraterm, realterm, or putty. Find the serial port name and COM port number in Control Panel View devices and printers. The Mbed board will appear as USB Serial Device or mbed Serial Port. Refer to <https://os.mbed.com/handbook/Windows-serial-configuration> and <https://os.mbed.com/docs/mbed-os/v5.11/tutorials/windows-serial-driver.html> for troubleshooting. Start the terminal emulator and use the menu to connect to the serial port that belongs to the board. Pressing **ENTER** displays the firmware's banner message (see [Example Serial Console Session](#)).

In linux, install a terminal emulator such as minicom or picocom. For example, under Debian or Ubuntu linux, use

```
<PRE>
  sudo apt-get install picocom
</PRE>
```

In linux (Debian), find the serial port name as follows:

```
<PRE>
  # with the board not connected, get list of tty device names
  ls -l /dev/tty* >dev_tty_baseline
  # now connect the device to USB and find the new tty device name (such as /dev/ttyACM0)
  ls -l /dev/tty* | diff dev_tty_baseline -
</PRE>
```

The picocom terminal emulator runs from the tty console. The tty device name must be given on the command line when starting picocom. See man picocom for more details.

```
<PRE>
  picocom /dev/ttyACM0 --baud 9600
</PRE>
```

Pressing ENTER displays the firmware's banner message (see example session). Pressing CTRL+A and then CTRL+X exits picocom.

Example Serial Console Session

The firmware uses a USB serial port to communicate. Typing ? prints a menu of supported device commands.

```
<PRE>
  # Brief Example for MAX11410BOB Breakout Board

Main menu MAX11410 24-bit 1.9ksps Delta-Sigma ADC [serial]
? -- help
MAX11410 > ?
Main menu MAX11410 24-bit 1.9ksps Delta-Sigma ADC [serial]
? -- help
# -- lines beginning with # are comments
. -- selfTest
%Hn {pin: 0 1 2 3 4 5 6 7 8 9 14 15 16 17} -- High Output
%Ln {pin: 0 1 2 3 4 5 6 7 8 9 14 15 16 17} -- Low Output
%n {pin: 0 1 2 3 4 5 6 7 8 9 14 15 16 17} -- Input
%A -- analogRead
%SC SCLK=8000000=8.000MHZ CPOL=0 CPHA=0 -- SPI config
%SD -- SPI diagnostic messages hide
%SW mosi,mosi,...mosi -- SPI write hex bytes
A-Z,a-z,0-9 -- reserved for application use
! -- Init
```

```
$ -- Read_All_Voltages
R -- Measure_RTD
T -- Measure_Thermocouple
V -- Measure_Voltage
X0 -- Calibrate_Self_Offset_Gain
X1 -- Calibrate_PGA_Gain
XC extclk=? u_bn=? format=? refbufp_en=? refbufn_en=? ref_sel=? -- Configure_CTRL
XF linef=? rate=? -- Configure_FILTER
XI idac1_sel=? idac0_sel=? -- Configure_MUX_CTRL1
XM ainp=? ainm=? -- Configure_MUX_CTRL0
XP sigpath=? gain=? -- Configure_PGA
XR ref_sel=? -- Configure_CTRL_REF
XS vbias_mode=? brn_mode=? idac_mode=? -- Configure_SOURCE
XV vbias_ain7_ain0_bitmap=? -- Configure_MUX_CTRL2
@ -- print MAX11410 configuration
* -- read core registers
*regname? -- read register
*regname=regvalue -- write register
01 23 45 67 89 ab cd ef -- write and read raw hex codes
MAX11410 > *
  scan RegName...
PD=0x000000
CONV_START=0x000001
SEQ_START=0x00003a
CAL_START=0x000000
GP0_CTRL=0x0000c4
GP1_CTRL=0x0000c4
GP_CONV=0x000000
GP_SEQ_ADDR=0x00003a
FILTER=0x000034
CTRL=0x000002
SOURCE=0x00000b
MUX_CTRL0=0x00002a
MUX_CTRL1=0x0000ff
MUX_CTRL2=0x000000
PGA=0x000000
WAIT_EXT=0x000000
WAIT_START=0x000000
```

```
MAX11410 > R
Measure_RTD rtd_iout=7 rtd_ainp=8 rtd_ainn=9 Measure_RTD
  SPI MOSI-> 0x08 0x34 MISO<- 0xFF 0xFF
  SPI MOSI-> 0x09 0x00 MISO<- 0xFF 0xFF
  SPI MOSI-> 0x0A 0x0B MISO<- 0xFF 0xFF
  SPI MOSI-> 0x0B 0x89 MISO<- 0xFF 0xFF
  SPI MOSI-> 0x0C 0xF7 MISO<- 0xFF 0xFF
  SPI MOSI-> 0x0E 0x21 MISO<- 0xFF 0xFF
  SPI MOSI-> 0x05 0xC3 MISO<- 0xFF 0xFF
  SPI MOSI-> 0x05 0xC4 MISO<- 0xFF 0xFF
  SPI MOSI-> 0x01 0x01 MISO<- 0xFF 0xFF
  SPI MOSI-> 0xB0 0x00 0x00 0x00 MISO<- 0xFF 0xFF 0xFE 0xF5
  SPI MOSI-> 0xB8 0x00 0x00 0x00 MISO<- 0xFF 0x00 0x00 0x00
  SPI MOSI-> 0xB8 0x00 0x00 0x00 MISO<- 0xFF 0x00 0x00 0x00
  SPI MOSI-> 0xB8 0x00 0x00 0x00 MISO<- 0xFF 0x00 0x00 0x00
  SPI MOSI-> 0xB8 0x00 0x00 0x00 MISO<- 0xFF 0x00 0x00 0x00
  SPI MOSI-> 0xB8 0x00 0x00 0x00 MISO<- 0xFF 0x00 0x00 0x00
  SPI MOSI-> 0xB8 0x00 0x00 0x00 MISO<- 0xFF 0x00 0x00 0x00
  SPI MOSI-> 0xB8 0x00 0x00 0x00 MISO<- 0xFF 0x00 0x00 0x00
  SPI MOSI-> 0xB8 0x00 0x00 0x00 MISO<- 0xFF 0x00 0x00 0x00
  SPI MOSI-> 0xB8 0x00 0x00 0x00 MISO<- 0xFF 0x00 0x00 0x00
  SPI MOSI-> 0xB8 0x00 0x00 0x00 MISO<- 0xFF 0x00 0x00 0x00
  SPI MOSI-> 0xB8 0x00 0x00 0x00 MISO<- 0xFF 0x00 0x00 0x00
  SPI MOSI-> 0xB8 0x00 0x00 0x00 MISO<- 0xFF 0x00 0x00 0x00
  SPI MOSI-> 0xB8 0x00 0x00 0x00 MISO<- 0xFF 0x00 0x00 0x00
  SPI MOSI-> 0xB8 0x00 0x00 0x00 MISO<- 0xFF 0x00 0x00 0x00
  SPI MOSI-> 0xB8 0x00 0x00 0x00 MISO<- 0xFF 0x00 0x00 0x00
  SPI MOSI-> 0xB8 0x00 0x00 0x00 MISO<- 0xFF 0x01 0x00 0x10
  SPI MOSI-> 0xB0 0x00 0x00 0x00 MISO<- 0xFF 0x7F 0xFF 0xFF
  SPI MOSI-> 0x0C 0xFF MISO<- 0xFF 0xFF =1.250000
rtd_ohm=1.250000
rtd_degc=-243.878942
MAX11410 > V ainp=2
```



```

Measure_Voltage ainp=2 ainn=10 Measure_Voltage
  SPI MOSI-> 0x0B 0x2A MISO<- 0xFF 0xFF
  SPI MOSI-> 0x09 0x02 MISO<- 0xFF 0xFF
  SPI MOSI-> 0x0E 0x00 MISO<- 0xFF 0xFF
  SPI MOSI-> 0x08 0x34 MISO<- 0xFF 0xFF
  SPI MOSI-> 0x01 0x01 MISO<- 0xFF 0xFF
  SPI MOSI-> 0xB0 0x00 0x00 0x00 MISO<- 0xFF 0x7F 0xFF 0xFF
  SPI MOSI-> 0xB8 0x00 0x00 0x00 MISO<- 0xFF 0x00 0x00 0x00
  SPI MOSI-> 0xB8 0x00 0x00 0x00 MISO<- 0xFF 0x00 0x00 0x00
  SPI MOSI-> 0xB8 0x00 0x00 0x00 MISO<- 0xFF 0x00 0x00 0x10
  SPI MOSI-> 0xB0 0x00 0x00 0x00 MISO<- 0xFF 0xFF 0xFE 0xFE ==-0.000077
MAX11410 > %SD
MAX11410 > v ainp-2 =2
Measure_Voltage ainp=2 ainn=10 Measure_Voltage
  ==-0.000083
MAX11410 > $
Read_All_Voltages =1
AINcode[0]=4383421 = 0x0042e2bd
AINcode[1]=2787149 = 0x002a874d
AINcode[2]=16776922 = 0x00ffffeda
AINcode[3]=16776952 = 0x00ffffef8
AINcode[4]=475880 = 0x000742e8
AINcode[5]=16776922 = 0x00ffffeda
AINcode[6]=461652 = 0x00070b54
AINcode[7]=16776921 = 0x00ffffed9
AINcode[8]=16776945 = 0x00ffffef1
AINcode[9]=16776918 = 0x00ffffed6
AINcode[10]=8388607 = 0x007fffff
MAX11410 > @
ref0_v = 2.500000
ref1_v = 4999.000000
ref2_v = 2.500000
avdd_v = 3.300000
ctrl = 2 = 0x00000002
pgaGain = 1 = 0x01
status = 65552 = 0x00010010
data0 = 8388607 = 0x007fffff
AINcode[0] = 4383421 = 0x0042e2bd
AINcode[1] = 2787149 = 0x002a874d

```

```
AINcode[2] = 16776922 = 0x00ffffeda
AINcode[3] = 16776952 = 0x00ffffef8
AINcode[4] = 475880 = 0x000742e8
AINcode[5] = 16776922 = 0x00ffffeda
AINcode[6] = 461652 = 0x00070b54
AINcode[7] = 16776921 = 0x00ffffed9
AINcode[8] = 16776945 = 0x00ffffef1
AINcode[9] = 16776918 = 0x00ffffed6
AINcode[10] = 8388607 = 0x007ffffff
loop_limit = 3000 = 0x0bb8
rtd_ms = 100
rtd_ohm = 1.250000
rtd_degc = -243.878942
rtd_filter = 52 = 0x34
rtd_ctrl = 0 = 0x00
rtd_source = 11
rtd_pga = 33 = 0x21
tc_v = 0.000000
tc_delta_degc = 0.000000
tc_degc = 0.000000
```

```
MAX11410 > @ ref0+v _v=1.25
ref0_v = 1.250000
ref1_v = 4999.000000
ref2_v = 2.500000
avdd_v = 3.300000
ctrl = 2 = 0x00000002
pgaGain = 1 = 0x01
status = 65552 = 0x00010010
data0 = 8388607 = 0x007ffffff
AINcode[0] = 4383421 = 0x0042e2bd
AINcode[1] = 2787149 = 0x002a874d
AINcode[2] = 16776922 = 0x00ffffeda
AINcode[3] = 16776952 = 0x00ffffef8
AINcode[4] = 475880 = 0x000742e8
AINcode[5] = 16776922 = 0x00ffffeda
AINcode[6] = 461652 = 0x00070b54
AINcode[7] = 16776921 = 0x00ffffed9
AINcode[8] = 16776945 = 0x00ffffef1
```

```

AINcode[9] = 16776918 = 0x00ffffed6
AINcode[10] = 8388607 = 0x007fffff
loop_limit = 3000 = 0x0bb8
rtd_ms = 100
rtd_ohm = 1.250000
rtd_degc = -243.878942
rtd_filter = 52 = 0x34
rtd_ctrl = 0 = 0x00
rtd_source = 11
rtd_pga = 33 = 0x21
tc_v = 0.000000
tc_delta_degc = 0.000000
tc_degc = 0.000000
MAX11410 >

```

</PRE>

Detailed Description of Hardware

The MAX11410 is a 24-bit, 1.9ksps, delta-sigma ADC. Connect analog inputs to the AIN0–AIN9 header pins. (The first 6 analog inputs are also connected to the standard Arduino analog pins on the external connector.) The MAX6126 provides the 2.5V analog reference voltage. The MAX8511 provides a low-dropout 3.3V supply. The MAX14931 digital isolator translates the external logic signals in the range of 1.71V to 5.5V for use with the MAX11410's 3.3V supply. For more information on these products, refer below:

- <https://www.maximintegrated.com/max11410>
- <https://www.maximintegrated.com/max6126>
- <https://www.maximintegrated.com/max8511>
- <https://www.maximintegrated.com/max14931>

Measuring Temperature Using Thermocouple

Configure the MAX11410 breakout board to measure temperature using a thermocouple as follows:

- 1) Install optional series resistors at R3 and R8
- 2) Install optional shunt resistor or capacitor at R2

- 3) Connect the thermocouple wires to the board at the TC header site. The square marks the positive lead which connects to AIN5 through optional resistor R3.
- 4) For cold junction measurement, follow the instructions in *Measuring Temperature Using RTD*, and ensure the RTD is located close to the board.

External voltage reference U4 MAX6126 provides a highly accurate +2.5V reference voltage at REF2P.

The software library provides functions `Measure_Thermocouple` and `TemperatureOfTC_TypeK`, which implements ITS-90 Thermocouple Inverse Polynomial to calculate temperature difference ΔT based on thermocouple voltage. External reference provided to REF2P is compared with the voltage across the thermocouple, AIN5–AIN6. The thermocouple voltage indicates the temperature difference between the cold junction (where the thermocouple wires connect to the board) and the hot junction (where the thermocouple wires are welded together). For best accuracy, an RTD is used to measure the temperature of the cold junction, which is then added to the thermocouple temperature difference to give the temperature at the hot junction. (Note that cold junction and hot junction are just terms of art, the hot junction does not need to be hotter than the cold junction.)

Measuring Temperature Using RTD

Configure the MAX11410 breakout board to measure temperature using a resistive temperature device (RTD) as follows:

- 1) Connect the RTD wires to the board at the RTD header site.
- 2) Connect jumper shunt or wire across J1 (connecting AIN9 to REF1P)

The software library provides functions Measure_RTDT and TemperatureOfRTD, which implements ITS-90 inverse polynomial for PT-100 or PT-1000 RTD. The MAX11410 is configured to drive its internal current source from AIN8, through both the RTD and the high-accuracy reference resistor R1 between REF1P and REF1N. The ratio of

$(AIN8-AIN9)/(REF1P-REF1N)$ indicates the resistance ratio $R_{RTD}/R1$. The value of R1 must be known to good accuracy. The MAX11410 breakout board comes with a 4.99k, 0.01% resistor installed at R1. From the measured resistance of the RTD, the temperature is calculated.

The equivalent (simplified) formula for calculating temperature from RTD resistance measurement is as follows:

$R0 = 100.0$ or 1000.0 depending on PT-100 or PT-1000 type

$a = 3.9083e-3$

$b = -5.7750e-7$

$$rtd_degc = ((-R0 \times a) + (\sqrt{R0 \times R0 \times a \times a - 4 \times R0 \times b \times (R0 - rtd_ohm)})) / (2 \times R0 \times b)$$

Table 1. Jumper Functions

JUMPER	STATE	FUNCTION
J2	1-2*	Analog input AIN0 connects to Arduino pin A0
J3	1-2*	Analog input AIN1 connects to Arduino pin A1
J4	1-2*	Analog input AIN2 connects to Arduino pin A2
J5	1-2*	Analog input AIN3 connects to Arduino pin A3
J6	1-2*	Analog input AIN4 connects to Arduino pin A4
J7	1-2*	Analog input AIN5 connects to Arduino pin A5
JREF2P	1-2*	Analog reference input REF2P is driven by on-board +2.5V reference (MAX6126)
J8	1-2*	VDDREG supply is provided by on-board +3.3V regulator (MAX8511)
J13	1-2*	AVDD supply is provided by on-board +3.3V regulator (MAX8511)
J15	1-2*	VDDIO supply is provided by on-board +3.3V regulator (MAX8511)
J14	1-2*	2.5V reference force/sense connection point
J17	1-2*	MAX14931 GNDA-GNDB connection point
JREF1N	1-2*	Analog reference input REF1N ground reference
JREF2N	1-2*	Analog reference input REF2N ground reference
J1	Open*	AIN9 voltage measurement independent of REF1P reference resistor
	1-2	RTD sensor current flows from AIN9 into REF1P, for ratiometric measurement
TC	Open	Connection point for optional thermocouple temperature sensor
RTD	Open	Connection point for optional resistive temperature device sensor

*Default position

Ordering Information

PART	TYPE
MAX11410BOB#	Breakout Board

#Denotes RoHS compliance.

MAX11410 Breakout Board Bill of Materials

ITEM	REF_DES	DNI/DNP	QTY	MFG PART #	MANUFACTURER	VALUE	DESCRIPTION	COMMENTS
1	C1, C5, C10, C25, C28	-	5	C0603C105K4RAC; GRM188R71C105KA12; C1608X7R1C105K080AC; EMK107B7105KA; GCM188R71C105KA64; CGA3E1X7R1C105K080AC; 0603YC105KAT2A	KEMET;MURATA;TDK; TAIYO YUDEN;MURATA; TDK;AVX	1UF	CAPACITOR; SMT (0603); CERAMIC CHIP; 1UF; 16V; TOL=10%; MODEL=; TG=-55 DEGC TO +125 DEGC; TC=X7R	
2	C2-C4, C6, C7, C11-C13, C15-C17, C26, C27, C29, C31, C32	-	16	CC0603KRX7R0BB104; GRM188R72A104KA35; GCJ188R72A104KA01; HMK107B7104KA; 06031C104KAT2A; GRM188R72A104K	YAGEO;MURATA;MURATA; TAIYO YUDEN; AVX;MURATA	0.1UF	CAPACITOR; SMT (0603); CERAMIC CHIP; 0.1UF; 100V; TOL=10%; TG=-55 DEGC TO +125 DEGC; TC=X7R	
3	C8, C9, C14, C18, C20-C24, C30	-	10	C0603C103K2RAC	KEMET	0.01UF	CAPACITOR; SMT (0603); CERAMIC CHIP; 0.01UF; 200V; TOL=10%; MODEL=; TG=-55 DEGC TO +125 DEGC; TC=X7R	
4	C19	-	1	GRM21B5C1H203JA01	MURATA	0.02UF	CAPACITOR; SMT (0805); CERAMIC CHIP; 0.02UF; 50V; TOL=5%; TG=-55 DEGC TO +125 DEGC; TC=COG	
5	GND	-	1	5001	KEYSTONE	N/A	TEST POINT; PIN DIA=0.1IN; TOTAL LENGTH=0.3IN; BOARD HOLE=0.04IN; BLACK; PHOSPHOR BRONZE WIRE SILVER PLATE FINISH;	
6	H1-H4	-	4	PEC07SAAN	SULLINS ELECTRONICS CORP.	PEC07SAAN	CONNECTOR; MALE; THROUGH HOLE; BREAKAWAY; STRAIGHT; 7PINS; -65 DEGC TO +125 DEGC	
7	J1, RTD, TC	-	3	PEC02SAAN	SULLINS	PEC02SAAN	CONNECTOR; MALE; THROUGH HOLE; BREAKAWAY; STRAIGHT; 2PINS	
8	J9	-	1	SSQ-106-03-G-S	SAMTEC	SSQ-106-03-G-S	CONNECTOR; MALE; THROUGH HOLE; THROUGH-HOLE .025 SQ POST SOCKET; STRAIGHT; 6PINS	
9	J10, J12	-	2	SSQ-108-03-G-S	SAMTEC	SSQ-108-03-G-S	CONNECTOR; FEMALE; THROUGH HOLE; .025IN SQ POST SOCKET; STRAIGHT; 8PINS	
10	J11	-	1	SSQ-110-03-G-S	SAMTEC	SSQ-110-03-G-S	CONNECTOR; FEMALE; THROUGH HOLE; .025IN SQ POST SOCKET; STRAIGHT; 10PINS	
11	J21	-	1	TSW-106-08-S-D-RA	SAMTEC	TSW-106-08-S-D-RA	CONNECTOR; THROUGH HOLE; DOUBLE ROW; RIGHT ANGLE; 12PINS	
12	R1	-	1	RNCF0805TKY4K99	STACKPOLE ELECTRONICS INC.	4.99K	RES; SMT (0805); 4.99K; 0.01%;+/-5PPM/DEGC; 0.125W	
13	R4-R7, R10-R15	-	10	CRCW06031K00FK; ERJ-3EKF1001	VISHAY DALE;PANASONIC	1K	RESISTOR; 0603; 1K; 1%; 100PPM; 0.10W; THICK FILM	
14	U1	-	1	MAX11410ATI+	MAXIM	MAX11410ATI+	IC; ADC; 24-BIT MULTI-CHANNEL LOW-POWER 1.9KSPS DELTA-SIGMA ADC WITH PGA; TQFN28-EP	
15	U2	-	1	MAX8511EXK33+	MAXIM	MAX8511EXK33+	IC; VREG; ULTRA-LOW-NOISE, HIGH PSRR, LOW-DROPOUT, LINEAR REGULATOR; SC70-5	
16	U3	-	1	MAX14931BASE+	MAXIM	MAX14931BASE+	IC; DISO; 3/1 CHANNEL; 25MBPS; 2.75KVRMS DIGITAL ISOLATOR; NSOIC16 150MIL	
17	U4	-	1	MAX6126AASA25+	MAXIM	MAX6126AASA25+	IC; VREF; ULTRA HIGH PRECISION; ULTRA LOW NOISE VOLTAGE REFERENCE; SOIC8 150MIL; VOUT=2.5V, 3PPM/DEGC MAX TEMP; NSOIC8	
18	PCB	-	1	11410_ARDUINO_DEMO_A	MAXIM	PCB	PCB:11410_ARDUINO_DEMO_A	-
19	R2, R3, R8	DNP	0	CRCW06031K00FK; ERJ-3EKF1001	VISHAY DALE;PANASONIC	1K	RESISTOR; 0603; 1K; 1%; 100PPM; 0.10W; THICK FILM	DNI
TOTAL			61					

MAX11410 Breakout Board Schematic

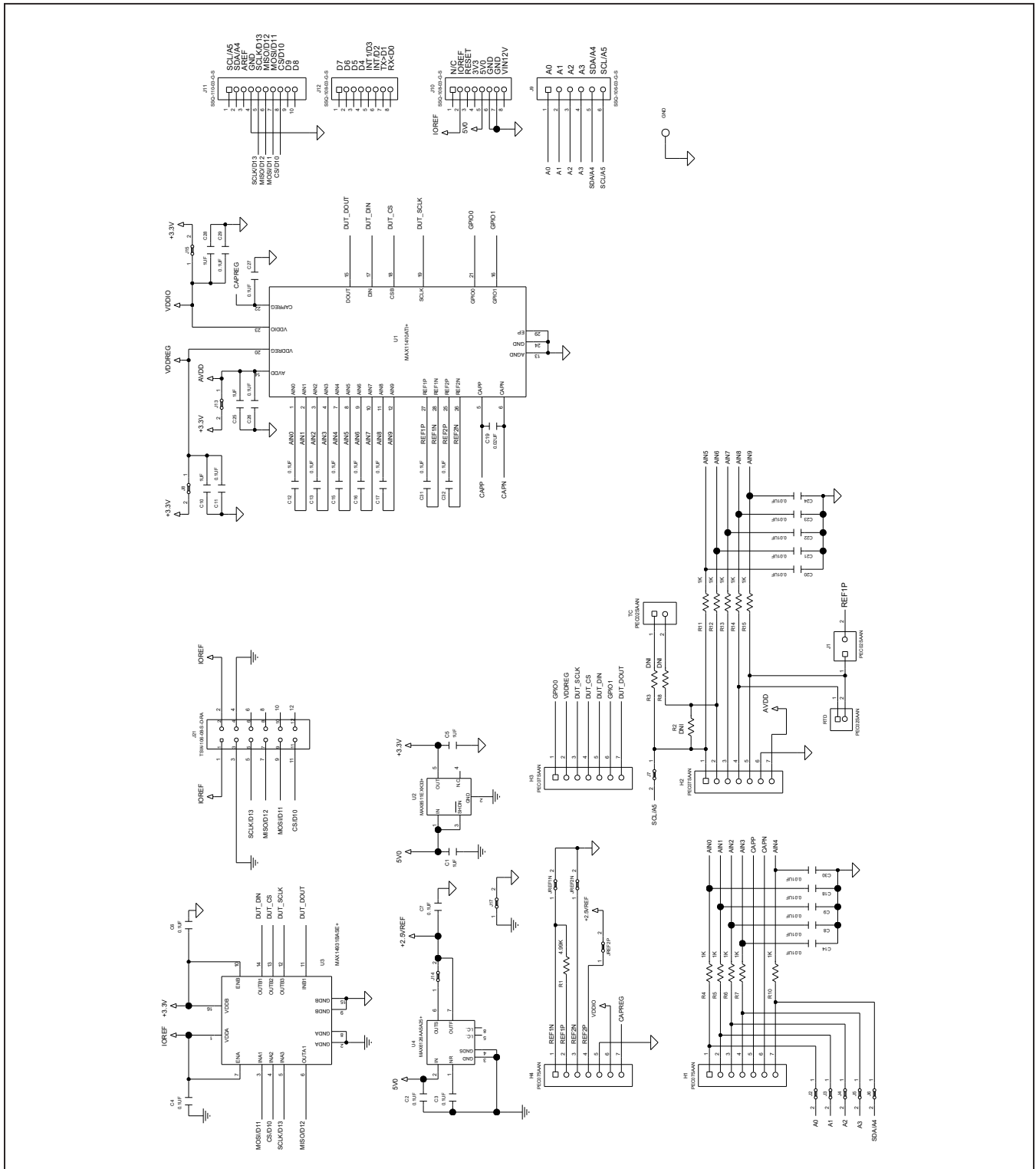

MAX11410 PCB Layout Diagrams

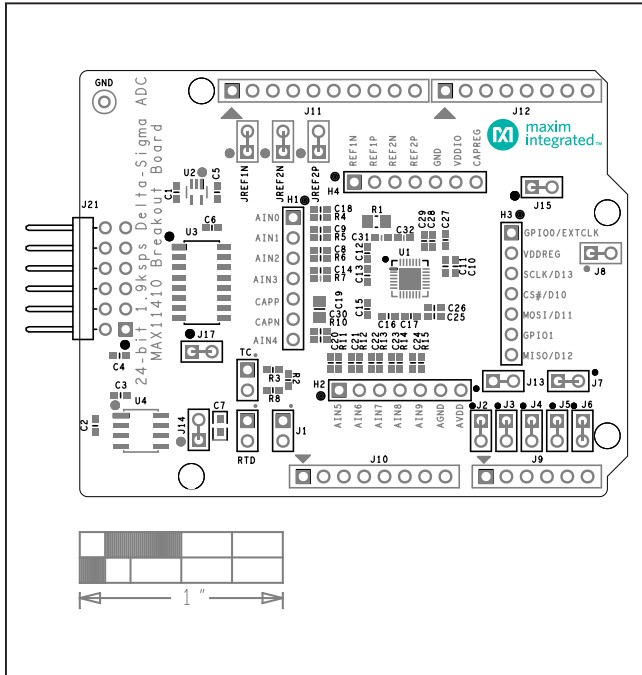

MAX11410 Breakout Board EV Kit Component Placement Guide—Top Silkscreen

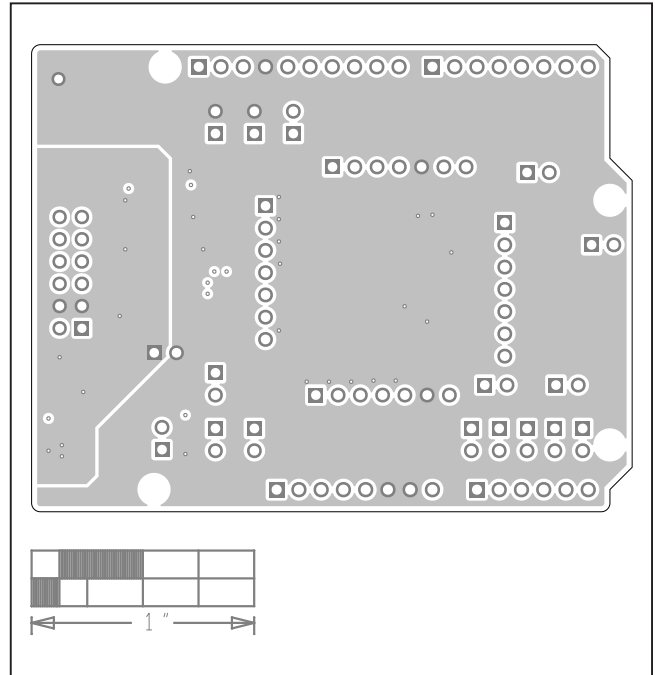

MAX11410 Breakout Board EV Kit PCB Layout—Internal2

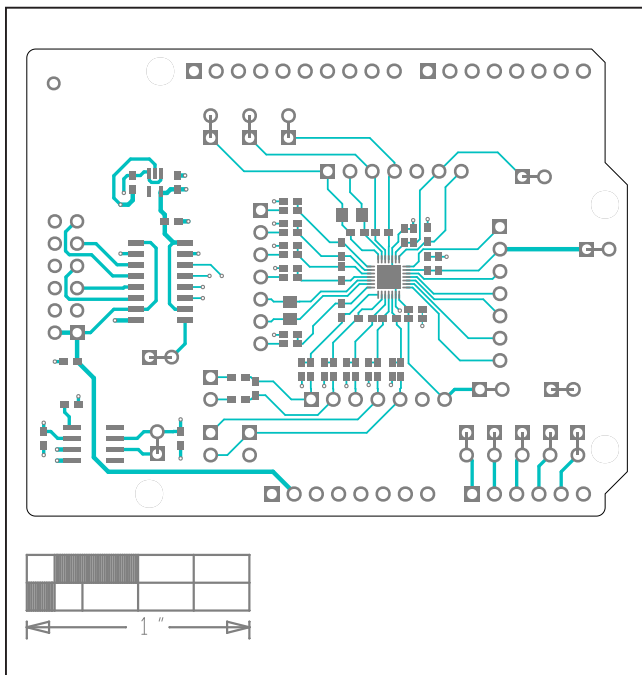

MAX11410 Breakout Board EV Kit PCB Layout—Top

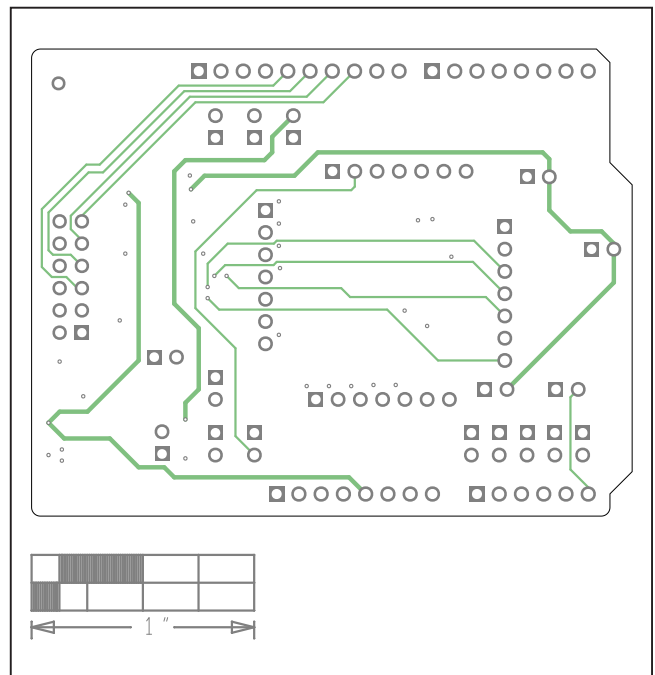

MAX11410 Breakout Board EV Kit PCB Layout—Internal3

MAX11410 PCB Layout Diagrams (continued)

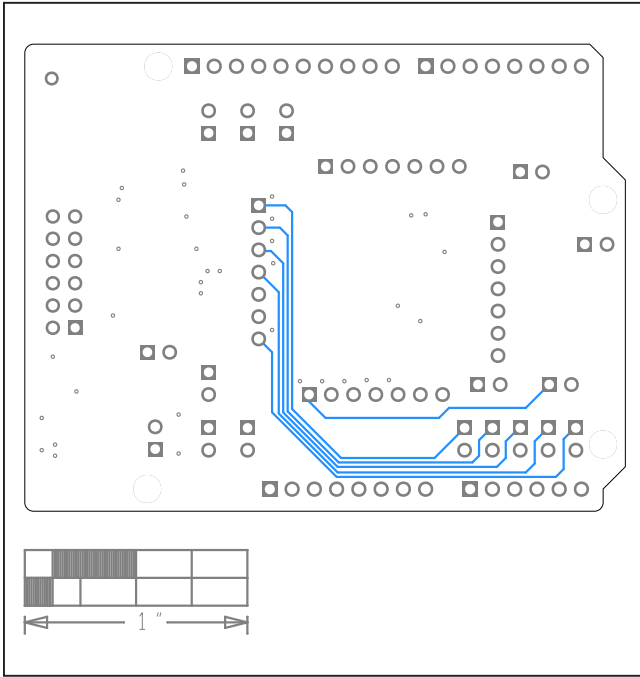

MAX11410 Breakout Board EV Kit PCB Layout—Bottom

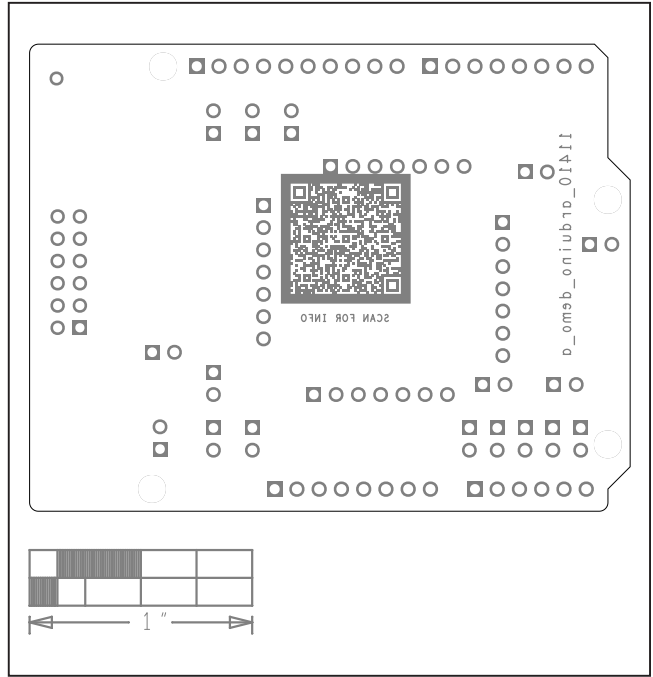

MAX11410 Breakout Board EV Kit Component Placement Guide—Silk Bottom

Revision History

REVISION NUMBER	REVISION DATE	DESCRIPTION	PAGES CHANGED
0	10/20	Initial release	—

For pricing, delivery, and ordering information, please visit Maxim Integrated's online storefront at <https://www.maximintegrated.com/en/storefront/storefront.html>.

Maxim Integrated cannot assume responsibility for use of any circuitry other than circuitry entirely embodied in a Maxim Integrated product. No circuit patent licenses are implied. Maxim Integrated reserves the right to change the circuitry and specifications without notice at any time.