

MAX1471 Evaluation Kit

Evaluates: MAX1471

General Description

The MAX1471 evaluation kit (EV kit) simplifies evaluation of the MAX1471, a low power, superheterodyne, sub-GHz RF dual-channel receiver designed to receive both amplitude shift keying (ASK) and frequency-shift keying (FSK) data without reconfiguring the device in the 300MHz to 450MHz frequency range.

The MAX1471 evaluation kit operates in conjunction with an external microcontroller (MCU) and graphical user interface (GUI) software running on a computer. The MAX1471 uses an SPI interface for internal register configurations and control.

The MAX1471 EV kit is available in two versions: 315MHz (MAX1471EVKIT-315) and 433.92MHz (MAX1471EVKIT-433). The passive components are optimized for these two frequencies but can easily be changed to work at any RF frequency between 300MHz and 450MHz.

The EV kit includes Windows® 10-compatible software that provides a simple GUI for configuration of the MAX1471 registers through the SPI port. The GUI also controls the on-board PMIC and provides a quick start register configuration to evaluate the MAX1471 functionality, when the MAX32630FTHR applications platform is used.

Features

- Evaluates the MAX1471 Sub-1GHz ISM Receiver
- Single Input Voltage Supply from 2.4V to 5.5V or Powered from the USB Interface
- Direct Interface with a MAX32630FTHR Arm® Microcontroller (MCU) Board
- Available in 315MHz- or 433.92MHz-Optimized Versions
- Available PMOD Hardware Interface
- Windows 10-Compatible Software
- On-Board SPI Interface Control
- GUI Controls for the MAX32630FTHR Board PMIC Operation from 2.4V to 3.3V
- Proven 2-Layer PCB Design
- Fully Assembled and Tested

[Ordering Information](#) appears at end of data sheet.

Windows is a registered trademark and registered service mark of Microsoft Corporation.

Click [here](#) for production status of specific part numbers.

MAX1471 Evaluation Kit

Evaluates: MAX1471

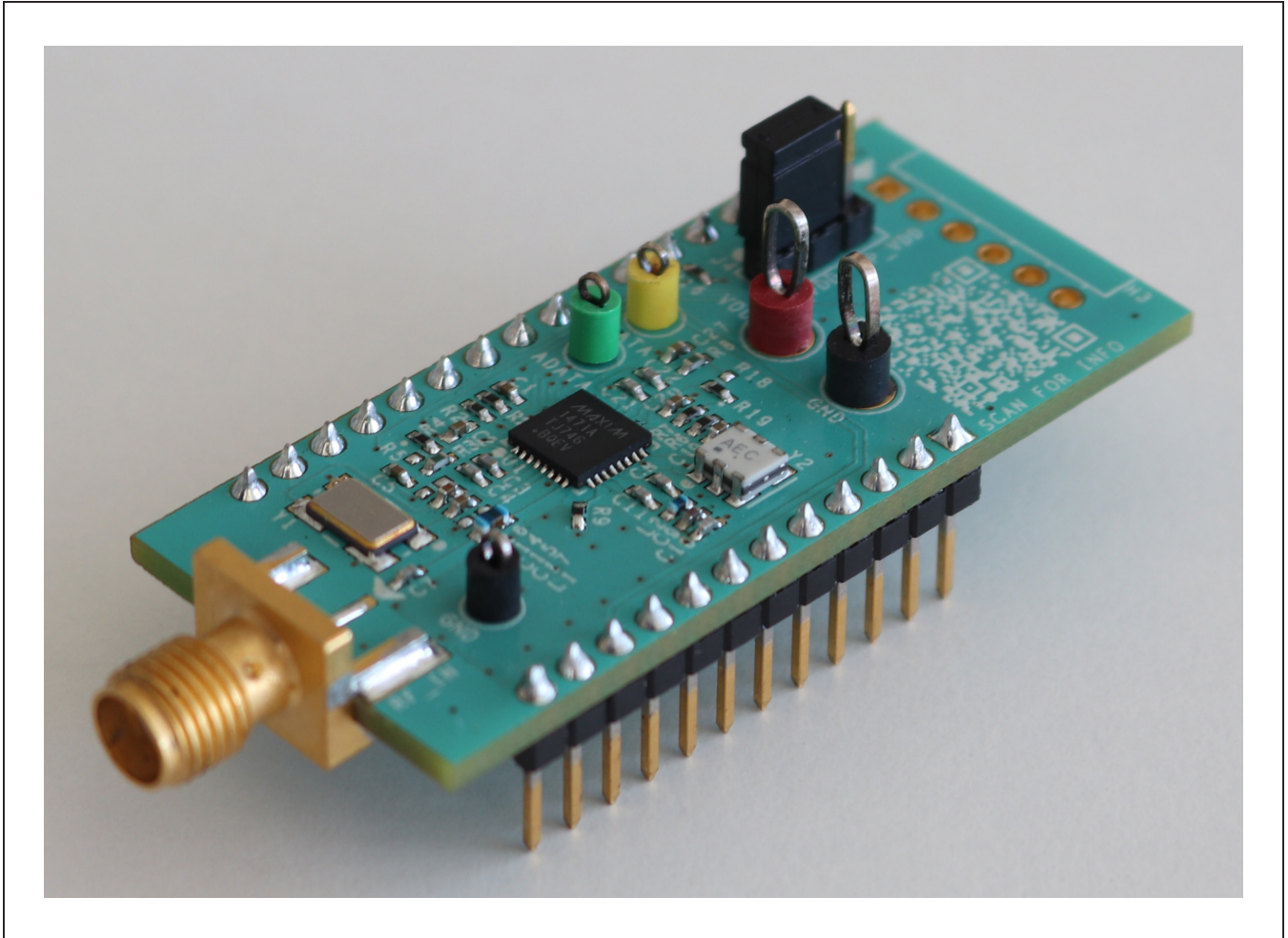

Figure 1. MAX1471 EV Kit Board

Quick Start

Required Equipment

- Included in the MAX1471 evaluation kit
 - MAX1471 evaluation kit board
 - MAX32630FTHR# kit
 - FTHR board
 - MAX32625PICO
 - 2x micro/B USB cables
- Windows PC* (Windows-10), with one to two USB2.0 ports available
- Power supply† capable of 2.4V to 5.5V, 100mA
- RF signal generator capable of delivering from -120dBm to 0dBm of output power at operating frequency, in addition to AM or Pulse modulation and FM modulation capabilities
- Dual-trace oscilloscope
- SMA/SMA cable as needed for connection to the RF signal generator

Software and Drivers

The MAX1471 EV kit can be used in conjunction with the Arm® Cortex®-M4 processor with FPU MAX32630FTHR application platform or FTHR board to provide power and control the device through a GUI software application. For this option, additional equipment is required.

When connected to the FTHR board, the MAX1471 EV kit uses the following drivers and software components. See the [Appendix I](#) for additional information on this installation process.

- **MAX1471 Software Package**

The software, firmware, and drivers are available from the www.maximintegrated.com website. Login to the MyMaxim account on the website, search for the MAX1471 part or EVKIT, click on the **Design Resources** tab, and click on the **ISM RADIO GUI** software link. Finally, click the file link on the software landing page to download the ISMRADIOGUI package.

- **Mbed™ MAX32630FTHR and DAPLINK Interface System**

The DAPLINK system is not required unless a firm-ware update to the FTHR board has been released. The FTHR board included in the MAX1471 EV kit is preprogrammed for interfacing the GUI to the radio. The firmware programming process does not require additional software or drivers, it uses a simple USB drive, drag-and-drop file interface.

It is highly recommended that the target PC be connected to a local area network and have access to the Internet, allowing automatic download and updates of some drivers. This process can take 15 minutes or more to complete.

Installation Procedure

The steps in this section are used when connecting the MAX1471 EV kit to a FTHR board and it needs only once, when configuring the hardware and the PC for the first time. If these steps have already been completed, jump directly to the [FTHR Board Quick Start Procedure](#) section.

Install the MAX1471EVKIT GUI Software

This process takes less than 10 minutes after downloading the software package. See the [Appendix I](#) for detailed information on this installation process.

- 1) Double-click the ISMRadiosGUISetup.msi setup file and follow the setup wizard prompts.
 - a) Click **Next** in the ISM Radio GUI setup wizard window.
 - b) It is recommended to use the default destination folder; click **Next** to continue.
 - c) Install the software by clicking the **Install** button.
 - d) Click **Finish** when the ISM radio GUI setup wizard installation process is complete.

Table 1. MAX1471 EV Kit Installed Files and Folders

FILE NAME	DESCRIPTION
ISM RADIO GUI.exe	Application GUI
MaximStyle.dll	Supporting DLL file for software operation
MAX1471_Registers.xml	Register definition file

*required for operation of the MAX1471 EV kit with the GUI software.

†required when the FTHR board is not connected to the MAX1471EV kit.

Mbed is a trademark of Arm Limited (or its subsidiaries) in the US and/or elsewhere.

Arm and Cortex are registered trademarks of Arm Limited (or its subsidiaries) in the US and/or elsewhere.

Update the MAX32630FTHR Board Driver on the Host PC

No changes are needed for the FTHR board when first receiving the MAX1471EVKIT—the FTHR board has been pre-loaded with the required firmware. Updates to the driver on the host PC may be necessary depending on the operating system and whether the PC has access to the internet when first connecting to the FTHR board. See the [Appendix I](#) for detailed information on how to update the FTHR board firmware and the driver for the FTHR board/USB interface.

Hardware Use Procedure

FTHR Board Quick Start Procedure—SPI Interface

Setup the MAX1471 EV Kit and FTHR Board Hardware MCU/GUI Operation

- 1) Verify the jumper on the MAX1471 EV kit board is in the default position, see [Table 2](#).
- 2) Connect the MAX1471 EV kit to the FTHR board, be sure the USB connector is oriented on the opposite side of the SMA connector as show in [Figure 3](#).

Table 2. MAX1471 EV Kit Jumper Settings

JUMPERS	POSITION	EV KIT FUNCTION
J4	1-2*	Power from L3OUT (FTHR board)
	2-3	Power from PMOD interface (VDD, pin 6 of JU4)

*Default position.

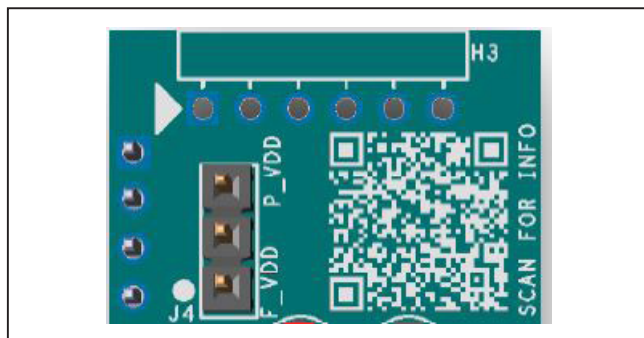

Figure 2. MAX1471 EV Kit Jumpers

- 3) Connect the FTHR board to the PC using a micro USB cable and observe a heartbeat on the FTHR board's red LED.
- 4) Connect the RF_IN to a signal generator using a low-loss SMA cable.
 - a) Set the frequency to the desired frequency of interest: for the MAX1471EVKIT-315 variant program the set frequency to 315MHz and for the MAX1471EVKIT-433 variant program the set frequency to 433.92MHz.
 - b) Set the power level out of the generator to -100dBm.
 - c) Set up and enable the ASK or FSK modulation. Use a 4kHz square wave (50% duty cycle) modulating signal for the ASK (use pulse modulation rather than AM if it is an available option on the signal generator). Use a 4kHz square wave (50% duty cycle) and 50kHz frequency deviation modulating signal for the FSK.
- 5) Connect the ADATA (ASK) or FDATA (FSK) test point output to the oscilloscope.

Table 3. MAX1471 EV Kit Test Points

NAME	COLOR	EVKIT FUNCTION
VDD	Red	2.4V to 5.5V power supply pin
GND	Black	Ground
FDATA	Yellow	FSK Demodulated data output
ADATA	Green	ASK Demodulated data output

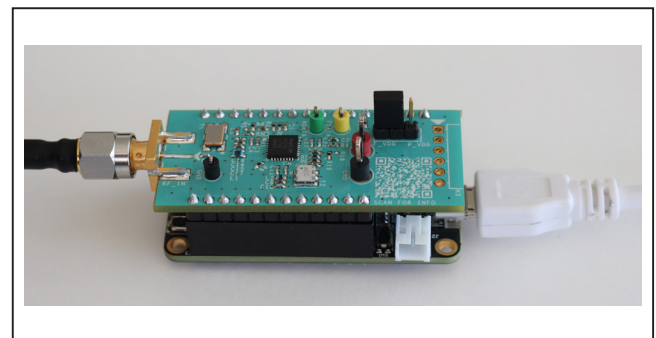

Figure 3. MAX1471 EV Kit Orientation to FTHR Board

- 6) Start the ISM Radios GUI control software.
 - a. An ISM Radios GUI splash screen as shown in [Figure 4](#) will be displayed.
 - i. To disable future displays of the splash screen, click on the **Disable Splash** check box.
 - ii. To continue to the GUI software when the select device message prompted as shown in [Figure 5](#), click on the **OK** button.
 - iii. Select the MAX1471-Rx from the **Device** drop-down menu as shown in [Figure 6](#).

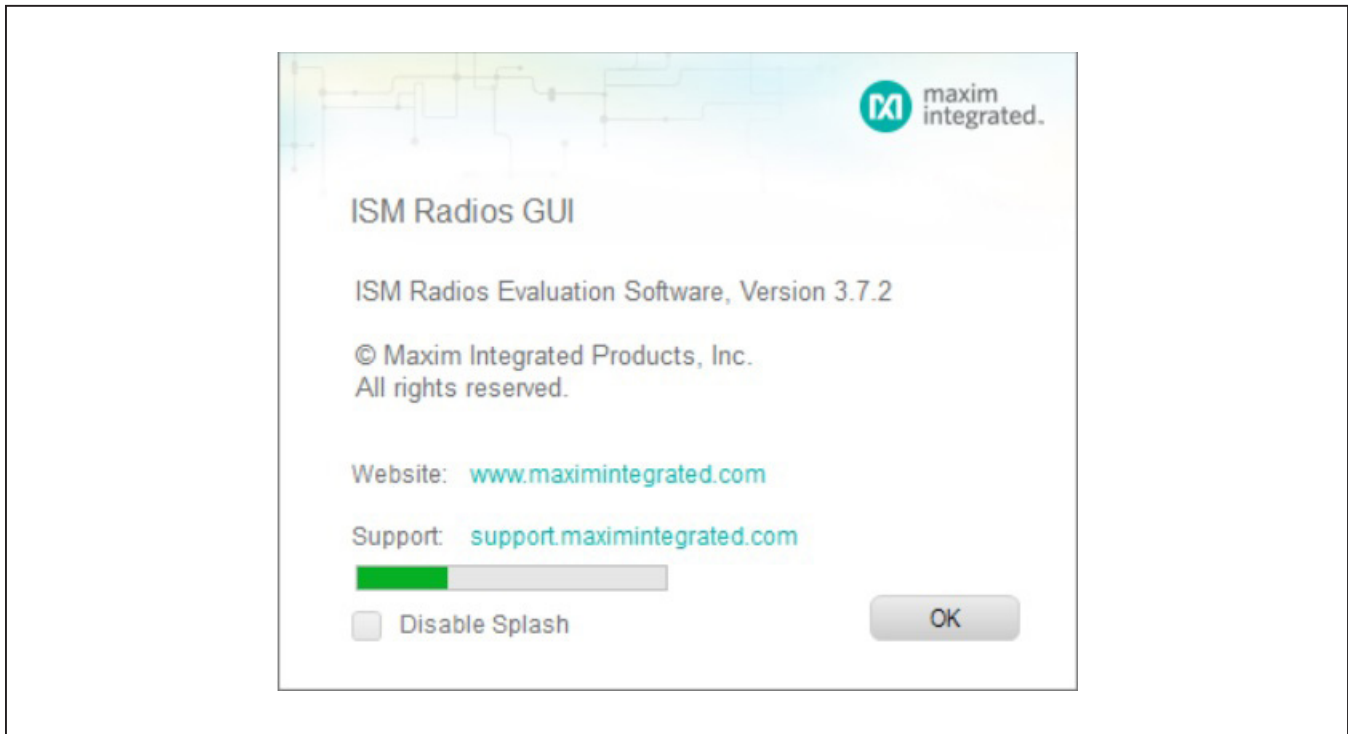

Figure 4. ISM Radios GUI Splash Screen



Figure 5. ISM Radios GUI Device Select Screen



Figure 6. ISM Radios GUI Device Select Screen

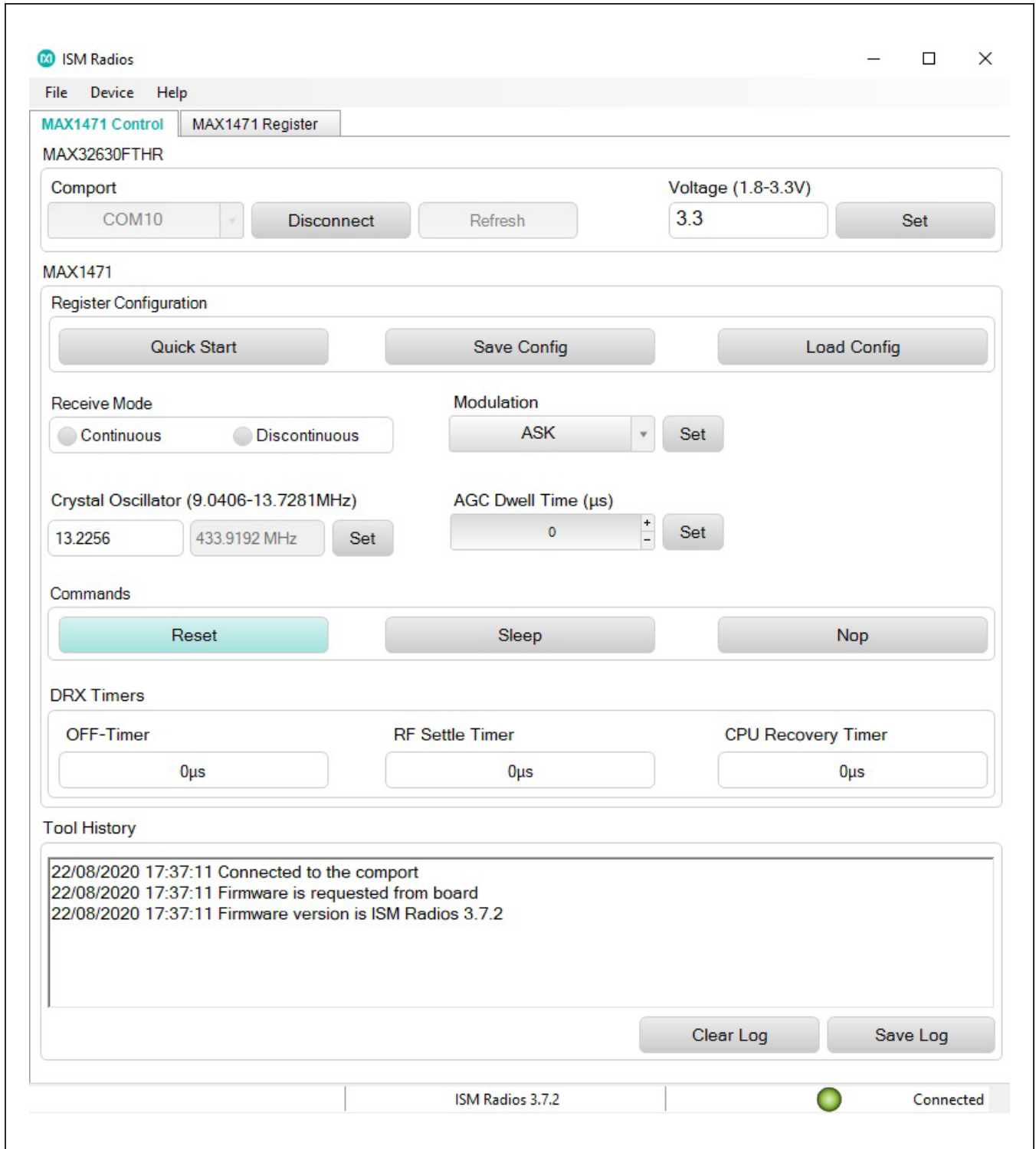

Figure 7. ISM Radio GUI Software

- b. The expected **Comport** displays if the EV kit was connected prior to starting the GUI. Select the appropriate Comport from the drop-down list and click on the **Connect** button. The **Connect** button changes to the **Disconnect** button.
 - c. Confirm the firmware status bar has changed from ISM Radios x.x.x to ISM Radios 3.0.0 or similar, the software LED is lit green, and the port status is noted as **Connected**.
 - d. Enter a supply level into the **Voltage** text box and click the **Set** button; for example, enter 3.3 for a 3.3V supply.
 - e. Select the **Quick Start** setting under Register Configuration.
 - f. Select the Receive mode to be **Continuous**.
 - g. Select a desired form of modulation in the **Modulation** drop-down box (to match signal generator setup) and click the **Set** button.
 - h. Enter a desired **Crystal Oscillator** frequency (for example, 9.509375MHz for 315MHz and 13.2256MHz for 433.92MHz) and click the **Set** button.
- 7) Observe the output on the oscilloscope.

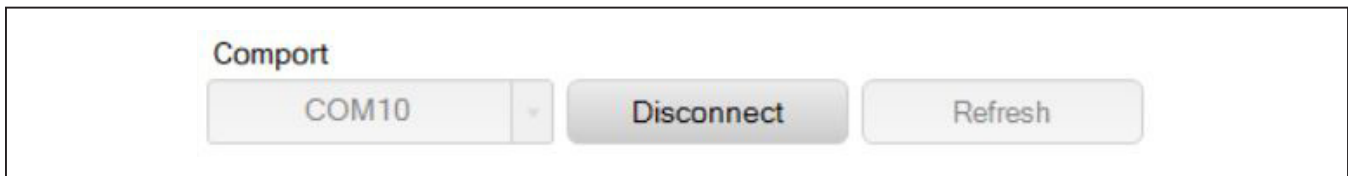

Figure 8. COM Port



Figure 9. Connected Indicators

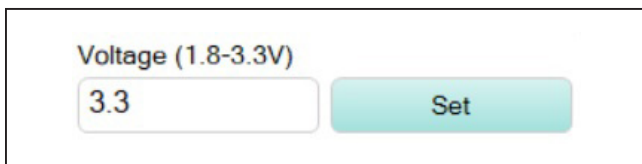

Figure 10. Supply Voltage

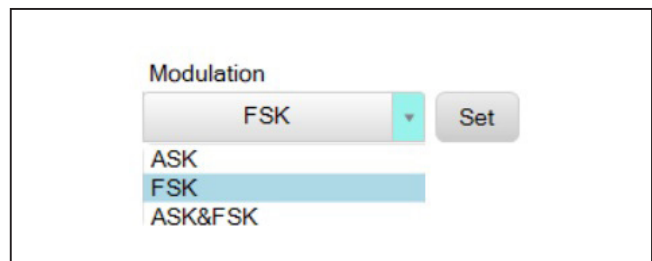

Figure 13. Modulation Selection



Figure 11. Register Configuration



Figure 12. Receive Mode

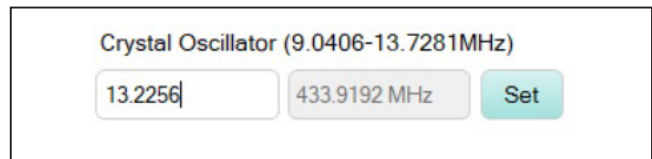

Figure 14. Crystal Oscillator Setting

ADATA

The digital baseband ASK demodulator data output signal can be monitored with the Green ADATA test point.

FDATA

The digital baseband FSK demodulator data output signal can be monitored with the Yellow FDATA test point.

PMOD Interface

The MAX1471 EV kit provides a PMOD-compatible header footprint to interface with the receiver. The H3 connector can be populated with a 6-pin, 100mil, right-angle header allowing direct connections to the CSB, DIO, SCLK, Ground, and VDD lines making it capable with SPI

PMOD interfacing. Populating this header allows control from the MAX32600MBED kit and the MAXREFDES72# Arduino® Uno R3 to PMOD shield adaptor. When using the PMOD interface to supply the MAX1471 EV kit with power, make sure to connect the J4 jumper between pins 2-3. See the [Appendix II](#) for detailed information on evaluation kit hardware modifications.

Detailed Description of Software

The MAX1471 EV kit controller GUI software is designed to control the MAX1471 evaluation kit board and the MAX32630FTHR board as shown in [Figure 3](#). The software includes USB controls which provide SPI communication to the MAX1471 through the FTHR board interface.

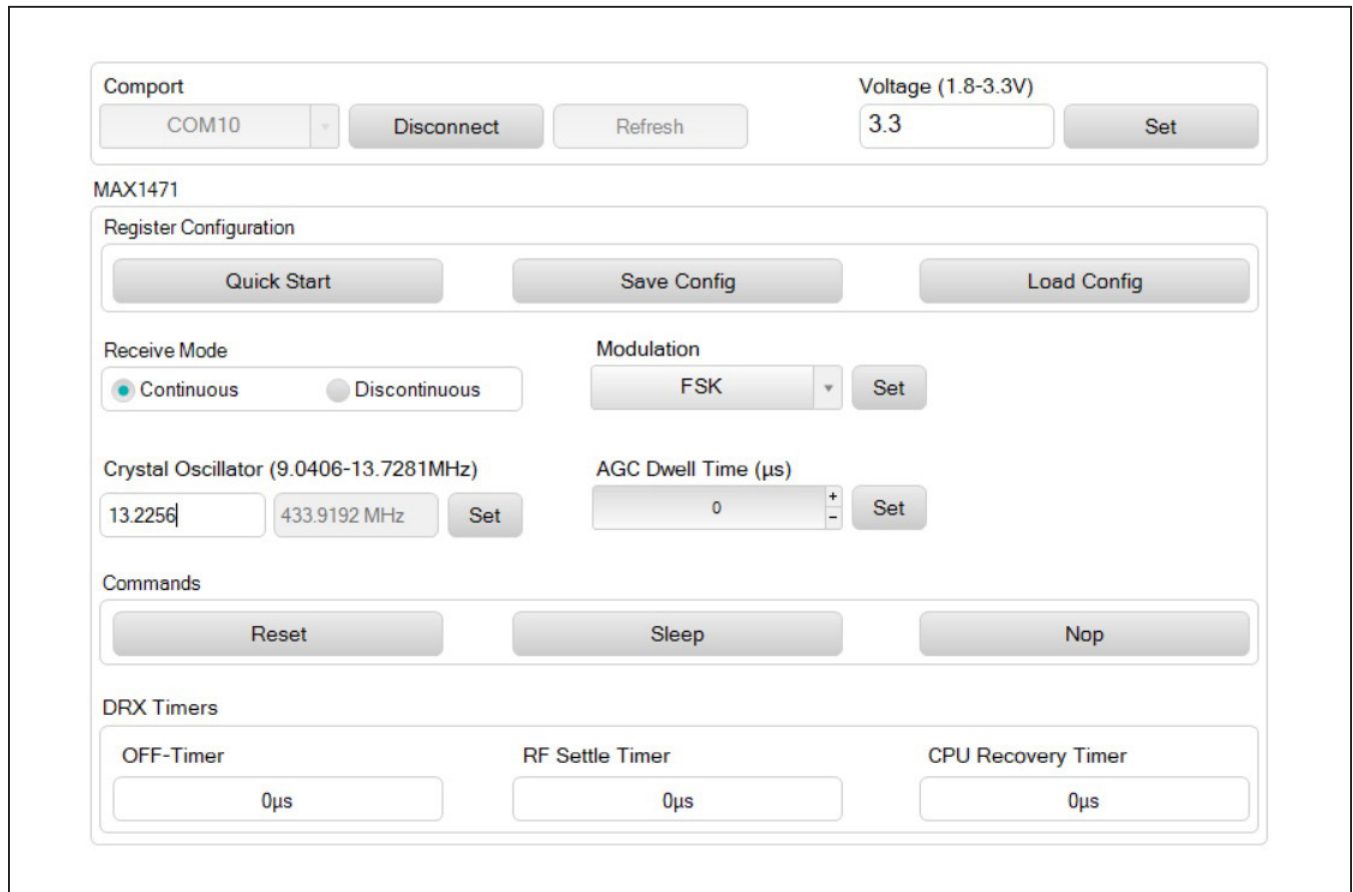

Figure 16. MAX1471 EV Kit GUI Configuration

Arduino is a registered trademark of Arduino, LLC.

Comport

The **Comport** section provides a drop-down selection of serial communication ports available for connection to the MAX1471 evaluation kit through a FTHR board. When the GUI is run after connecting the evaluation kit hardware, the drop-down box is default to the proper Comport. If the hardware is connected to the computer after the GUI is started, click on the **Refresh** button to scan for compatible ports. Once the appropriate Comport is selected in the drop-down box, click on the **Connect** button (See [Figure 8](#)).

After connecting to the **Comport** with the FTHR board, the GUI displays the revision of FTHR board firmware detected, display a Green LED, and display **Connected** in the status bar along the bottom of the GUI window (See [Figure 9](#)).

Voltage (2.4V–3.3V)

The **Voltage** section provides a user-adjustable power supply from the FTHR board MAX14690N power management IC (PMIC) to the MAX1471 EV kit and can be used as the primary VDD supply. The PMIC, L3OUT can be set to voltages between 2.4V and 3.3V and it applies to the level of the logic interface lines as well as the device supply (See [Figure 10](#)).

To program the supply voltage, enter a valid level in the **Voltage** text box and click on the **Set** button. The default value of the L3OUT voltage is 3.3V.

When using the FTHR board interface to supply the MAX1471 EV kit with power, make sure to connect the J4 jumper between pins 1-2.

Register Configuration

The MAX1471 GUI provides the three register configuration settings.

Quick Start: The **Quick Start** option configures the power configuration register. The quick start setting enables the LNA, AGC, mixer, baseband, and peak detector bits.

Save Config: The GUI configuration can be saved by clicking the **Save Config** button. The saved register configuration can be retrieved by clicking the **Load Config** button.

Load Config: A register configuration file can be loaded to the GUI by clicking the **Load Config** button.

Receive Mode

The MAX1471 operates in two modes: **Continuous** and **Discontinuous** receive modes.

Continuous Receive Mode: All analog modules are powered directly through the power configuration register.

Discontinuous Receive Mode: Power signals for the analog modules toggle between OFF and ON, according to the internal timers t_{OFF} , t_{CPU} , and t_{RF} (See the [DRX Timers](#)). This mode is used for the low power operation.

Modulation

The **Modulation** section allows the user to quickly set the form of modulation for the MAX1471 device. To select the modulation, choose ASK or FSK in the **Modulation** drop-down box and click on the **Set** button. (See [Figure 13](#)).

Crystal Oscillator (9.0406-13.7281MHz)

The **Crystal Frequency** section allows the user to indicate the frequency of the crystal installed on the MAX1471 EV kit (f_{XTAL}). This value can be adjusted between the 9.040606MHz and 13.7281MHz. Once appropriate crystal frequency is entered, the calculated receiver frequency value shows on the adjacent text box.

The XTAL oscillator frequency sets the received signal frequency as below:

$$f_{RECEIVE} = (f_{XTAL} \times 32) + 10.7\text{MHz}$$

The MAX1471EVKIT-315 evaluation kits come pre-populated with a 9.509375MHz crystal and the setting in the GUI is 9.509375MHz. The MAX1471EVKIT-433 evaluation kits come pre-populated with a 13.225625MHz crystal and the setting in the GUI is 13.225625MHz.

The MAX1471 has an internal frequency divider that divides down the crystal frequency to 100kHz. The hexadecimal value written to the oscillator frequency register is the nearest integer result of $f_{XTAL}/100\text{kHz}$. For example, if data is being received at 315MHz, the crystal frequency is 9.509375MHz. Dividing the crystal frequency by 100kHz and rounding to the nearest integer gives 95, or 0x5F hex. For 315MHz, 0x5F writes to the oscillator frequency register.

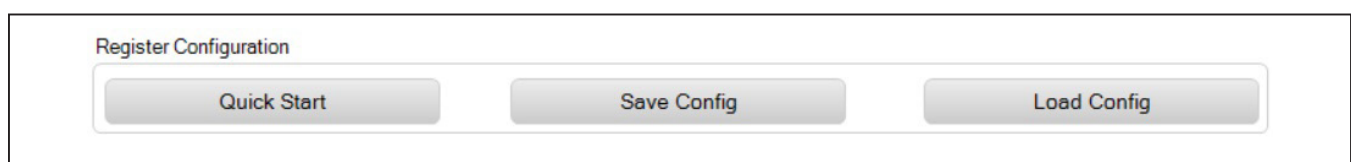

Figure 17. Register Configuration

To configure the reference oscillator, enter a valid frequency (in MHz) in the crystal frequency text box and click on the **Set** button (See [Figure 14](#)).

The **Crystal Oscillator** frequency can also be set manually through the [Direct Register Access Section](#) by clicking on the 0x03 OSC_FREQ (0x03) register, clicking on the FREQ [7:0] field, and typing in a hex value between 0x00 and 0xFF.

AGC Dwell Time

When AGC is enabled, it monitors the RSSI output. When the RSSI output reaches 1.28V, which corresponds to an RF input level of approximately -64dBm, the AGC switches on the LNA gain reduction attenuator. The attenuator reduces the LNA gain by 35dB, thereby reducing the RSSI output by about 0.55V. The LNA resumes high-gain mode when the RSSI output levels drop back below 0.68V (approximately -67dBm at RF input) for a programmable interval called **AGC Dwell Time**.

The **AGC Dwell Timer** holds the AGC in low gain for a set amount of time after the power level drops below the AGC switching threshold. After that set amount of time, if the power level is still below the AGC threshold, the LNA switches into the high-gain state.

The **AGC Dwell Time** is dependent on the crystal frequency and the bit settings of the AGC Dwell Time register. The GUI calculates the register values using the following equation:

$$\text{Dwell Time} = \left(\frac{2^{\text{Reg0xA}}}{f_{\text{XTAL}}} \right)$$

For Manchester code (50% duty cycle), set the dwell time to at least twice the bit period. For NRZ data, set the dwell to greater than the period of the longest string of zeroes or ones. For example, using the Manchester code at 315MHz ($f_{\text{XTAL}} = 9.509375$) with a data rate of 4kbps (bit period = 125µs), the dwell time needs to be greater than 250µs:

$$\text{Reg 0xA} \geq 3.3 \times \log_{10} (250\mu\text{s} \times 9.509375\text{MHz})$$

The calculated value would be ~11.14. The value should be rounded up to the nearest integer value. Therefore, the value of 12 or 0x0C should be chosen and set for the AGC dwell time register (0x0A).

To select the **AGC Dwell Time**, enter the timer value into the dwell time text box and click on the **Set** button.

The **AGC Dwell Time** can also be set manually through the [Direct Register Access Section](#) by clicking on the 0A AGCD_TMR (0x0A) register, clicking on the TMR [7:0] field, and typing in a hex value between 0x00 and 0xFF.

The default value of AGC dwell timer on power-up or reset is 0x0D.

Commands

The **Commands** section provides three command settings.

Reset: The **Reset** command sends the reset signal to all the internal registers of the MAX1471 just like a power-off and power-on sequence.

Sleep: The **Sleep** command puts the MAX1471 into deep-sleep mode when set.

Nop: The **Nop** command sends the No operation command bits to the MAX1471 internal register.

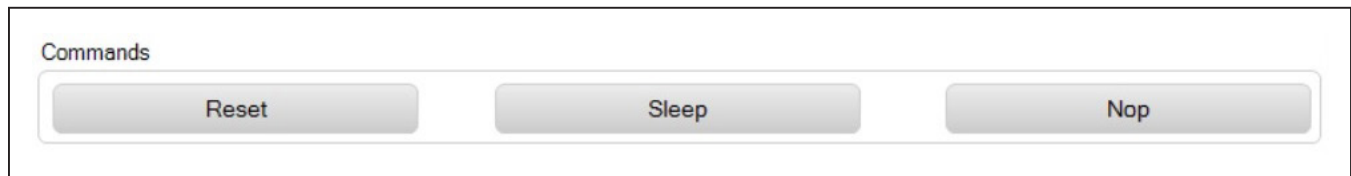

Figure 18. Commands

DRX Timers

The **DRX Timers** section allows the internal timers settings for the **Discontinuous** receive mode. On power up, timer registers are set to zero and must be written before using the DRX mode.

OFF-Timer:

The **OFF-Timer** is a 16-bit timer that is configured using: register 0x4 for the upper byte, register 0x5 for the lower byte, and bits PRESCALE1 and PRESCALE0 in the

configuration register (register 0x1). [Table 4](#) summarizes the configuration of the t_{OFF} timer. The PRESCALE1 and PRESCALE0 bits set the size of the shortest time possible (t_{OFF} time base). The data written to the t_{OFF} registers (0x4 and 0x5) is multiplied by the time base to give the total t_{OFF} time.

To configure the off-timer register, click on the **OFF-Timer** text box, set the appropriate timer value, and click the **Set** button.



Figure 19. DRX Timers

Table 4. OFF-Timer Configuration

PRESCALE1	PRESCALE0	t_{OFF} TIME BASE (1 LSB)	MIN t_{OFF} REG 0x4 = 0x00 REG 0x5 = 0x01	MAX t_{OFF} REG 0x4 = 0xFF REG 0x5 = 0xFF
0	0	120µs	120µs	7.86s
0	1	480µs	480µs	31.46s
1	0	1920µs	1.92ms	2 min 6s
1	1	7680µs	7.68ms	8 min 23s



Figure 20. OFF Timer Configuration

RF Settle Timer

The **RF Settle Timer** is used to allow the RF sections of the MAX1471 to power up and stabilize before ASK or FSK data is received. t_{RF} begins counting once t_{CPU} has expired. t_{RF} is a 16-bit timer, configured through registers 0x7 (upper byte) and 0x8 (lower byte). Table 5 summarize the configuration of t_{RF} timer. The data written to the t_{RF} register (0x7 and 0x8) is multiplied by 120 μ s to give the total t_{RF} time.

To configure the RF timer register, click on the **RF Settle Timer** text box, set the appropriate timer value, and click the **Set** button.

CPU Recovery Timer

The **CPU Recovery Timer** is used to delay the power-up of the MAX1471, thereby providing extra power saving and giving a CPU the time required to complete its own power-on sequence. t_{CPU} is an 8-bit timer, configured through register 0x6. Table 6 summarize the configuration of the t_{CPU} timer. The data written to the t_{CPU} register (0x6) is multiplied by 120 μ s to give the total t_{CPU} time.

To configure the CPU timer register, click on the **CPU Recovery Timer** text box, set the appropriate timer value, and click the **Set** button.

Tool History Section

This portion of the GUI contains a Log File text block, which is used to record activity within the GUI.

Table 5. RF-Timer Configuration

TIME BASE (1 LSB)	MIN t_{RF} REG 0x7 = 0x00 REG 0x8 = 0x01	MAX t_{RF} REG 0x7 = 0xFF REG 0x8 = 0xFF
120 μ s	120 μ s	7.86s

Table 6. CPU-Timer Configuration

TIME BASE (1 LSB)	MIN t_{CPU} REG 0x6 = 0x01	MAX t_{CPU} REG 0x6 = 0xFF
120 μ s	120 μ s	30.72ms

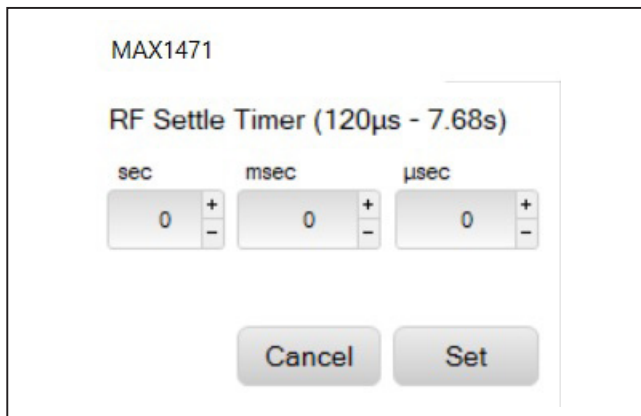

Figure 21. RF Settle Timer Configuration

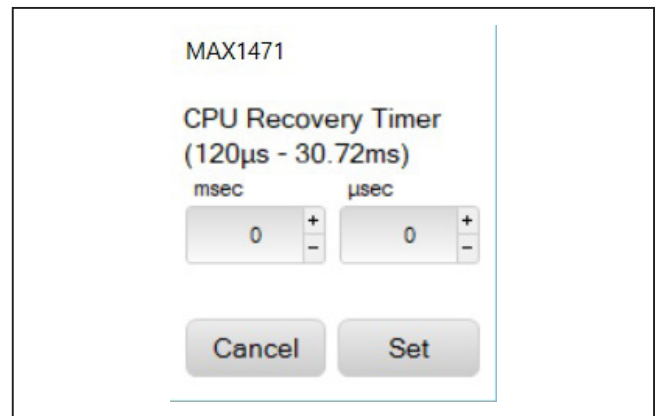

Figure 22. CPU Recovery Timer Configuration

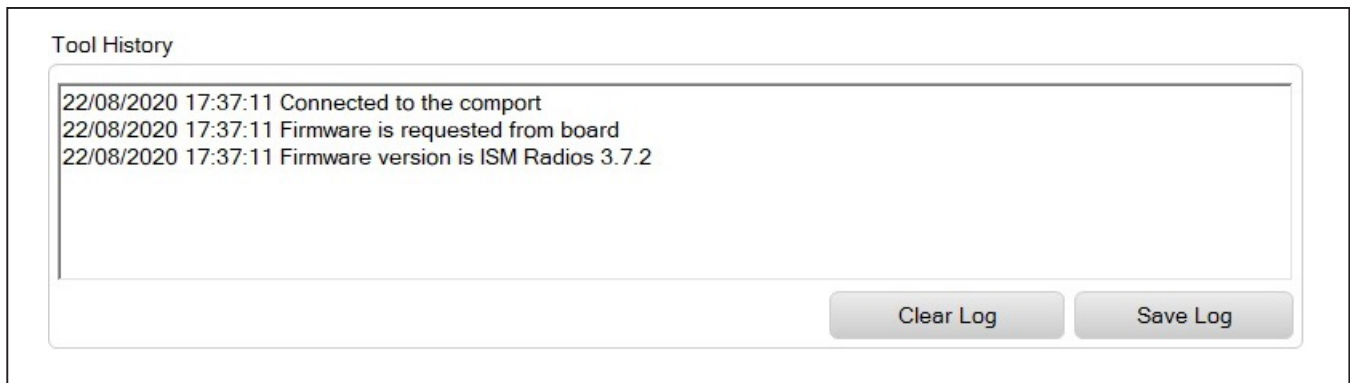

Figure 23. Tool History

Log File

For every set, connection effort, or register programming action, the GUI activity is logged in this text block. The user can add notes and make edits to the content of the **Log File** text block.

Clicking on the **Clear Log** button deletes the contents in the text block.

Clicking on the **Save Log** button opens a save as explorer window and the user prompts to save a .txt file.

Direct Register Access Section

The GUI software allows for direct access to all the available register when interfacing with the MAX1471 SPI mode.

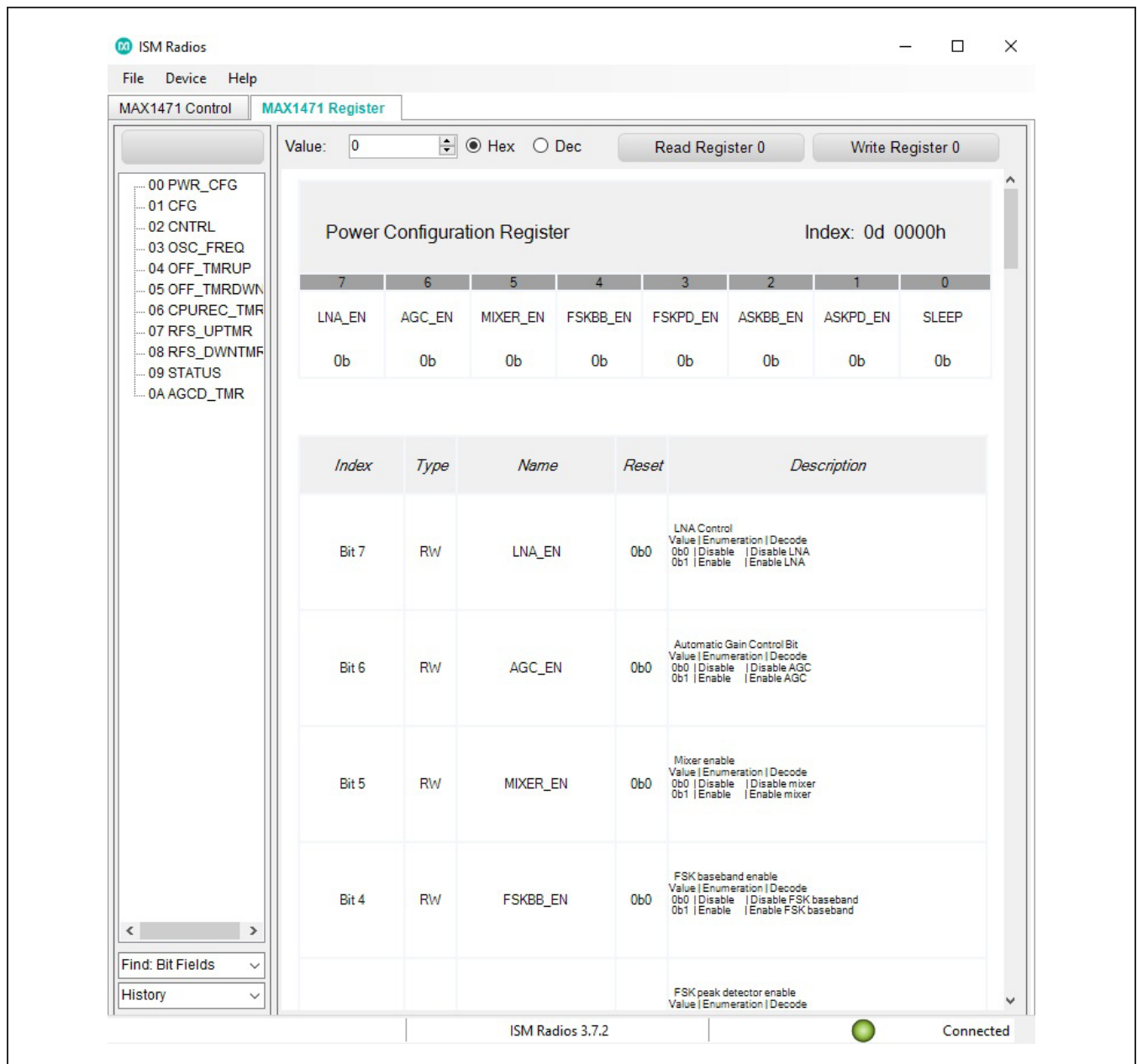

Figure 24. Register Interface

Register List

On the left-hand side of the register interface section is a list of the device's internal registers. Each register address/name (e.g. 00 PWR_CFG) acts as an active control, and by clicking on an individual register, the contents are presented in the [Register Value](#) section.

Register Value

The right-hand side of the register interface section displays the content of the selected device register. At the top of the block, a header displays the name of the selected register (e.g. PWR_CFG), the Index or address of the register in both decimal (0d) and hexadecimal (0000h) form.

The body of this section shows a table with the names of the individual bits for the selected 8b register along with the current value programmed into each bit or bit group.

The remaining portion of the body shows a table with the bit indexes, the type of register (write/read), the name of the bit or bit group, the reset value, and a description of the bit or bit group.

Read and Write Registers

Most of the registers in the MAX1471 are both readable and writable. The read-only register is STATUS (0x09). Writing values to a register can be accomplished by selecting the register of interest, typing a **Hex** or **Dec** value into the **Value** text box, and clicking on the **Write Register X** button (where X is the decimal address of the register).

Ordering Information

PART	TYPE
MAX1471EVKIT-315	MAX1471EVKIT tuned to 315MHz
MAX1471EVKIT-433	MAX1471EVKIT tuned to 433MHz

Component Suppliers

SUPPLIER	PHONE	WEBSITE
YXC Crystal	–	www.yxcxtal.com
Johnson Components/Cinch	–	www.belfuse.com/cinch
Keystone	800-221-5510	www.keyelco.com
Murata Electronics North America, Inc.	770-436-1300	www.murata.com
Panasonic	–	–
Sullins	760-744-0125	www.sullinscorp.com
Vishay Dale	800-433-5700	www.vishay.com

Note: Indicate that you are using the MAX1471 when contacting these component suppliers.

Reading the register content is similar: select the register of interest and click on the **Read Register X** button.

Register Bit Field

Individual bits can be programmed without having to enter the full value of the register. To program a bit, first select the register of interest (CFG, 0x01 for example), next click on the bit to be changed (CFG[3] as an example), the new value automatically reflects in the **Value** text box and writes to the device.

Miscellaneous Software Information

The tool bar along the top of the GUI window provides a couple of options to the user.

File and Help Menu

Selecting **File** → **Exit** from the tool bar closes the GUI program. This has the same effect as clicking the **X** button in the upper-right corner of the GUI software.

Selecting **Help** → **ICs** shows the list of MAXIM's ISM products supported by the GUI. Click the particular part number for the detailed product information.

Selecting **Help** → **About** from the tool bar displays the splash screen. This window shows the name of the software, the revision number, a copyright notice, a link to the Maxim website, a link to the support website, and a checkbox to enable or disable the splash screen during startup. Click the **OK** button to close the **About** window.

.xml File

The register descriptions for the MAX1471 GUI is available in an .xml file which is stored with the executable in the application directory. The default file loaded during initialization of the GUI is MAX1471_Registers.XML. This file can be edited as needed to adjust the names of fields, provide simple indicators to the GUI user, or allow for flexible updates to the GUI interface in the future.

Appendix I—Detailed Software, Firmware, and Driver Installation Procedures

Download the MAX1471EVKIT Software Package

This software and firmware are available from the www.maximintegrated.com website.

- 1) Login to the MyMaxim account on the website.

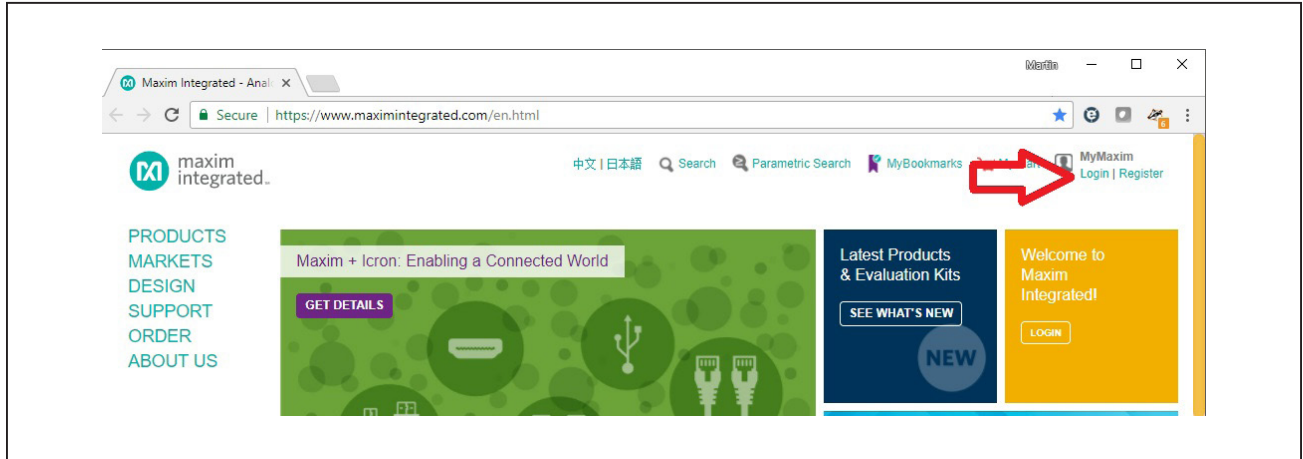

- 2) Click on the magnifying glass and search for the MAX1471 or similar part.

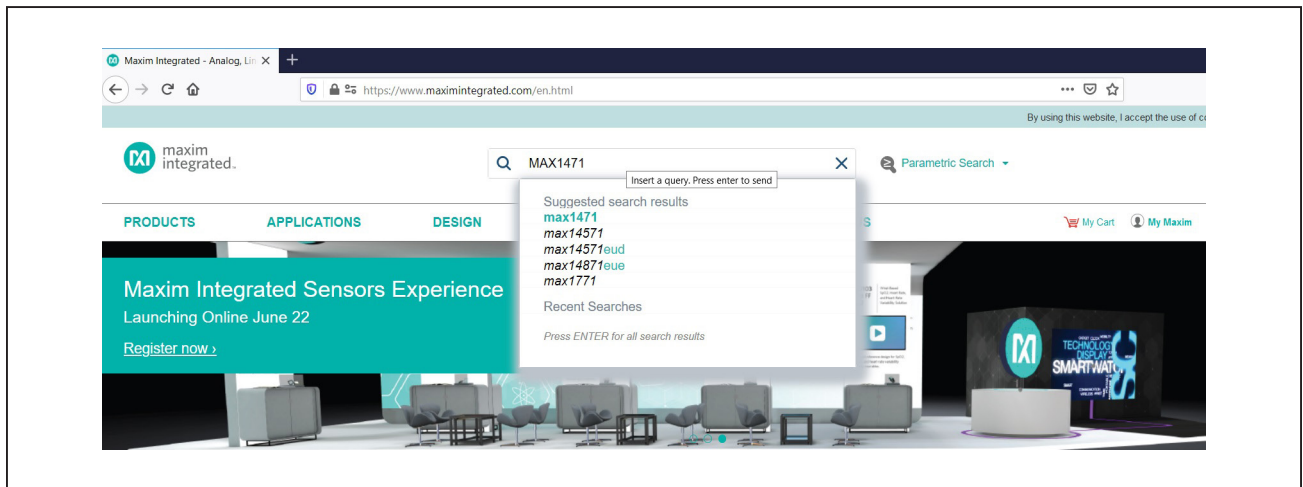

- 3) Click on the **Design Resources** link for the device or the EV kit or click on the **Design Resources** tab on the product web page.

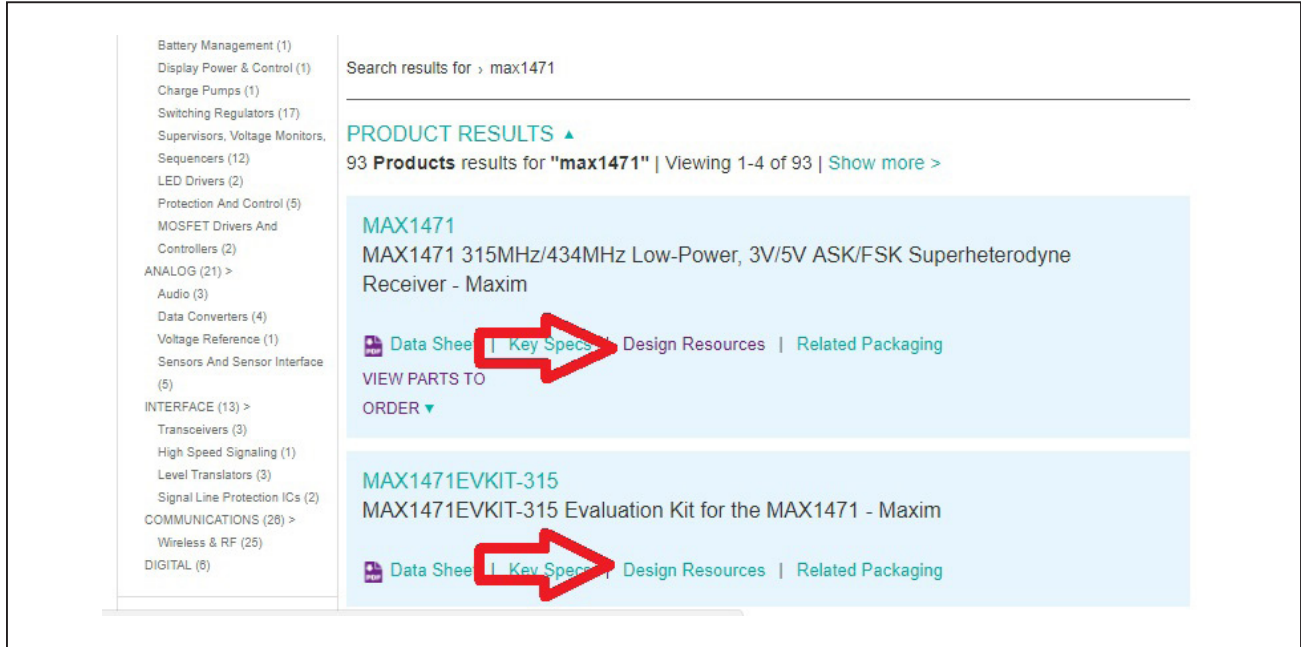

- 4) Click on the appropriate software link.

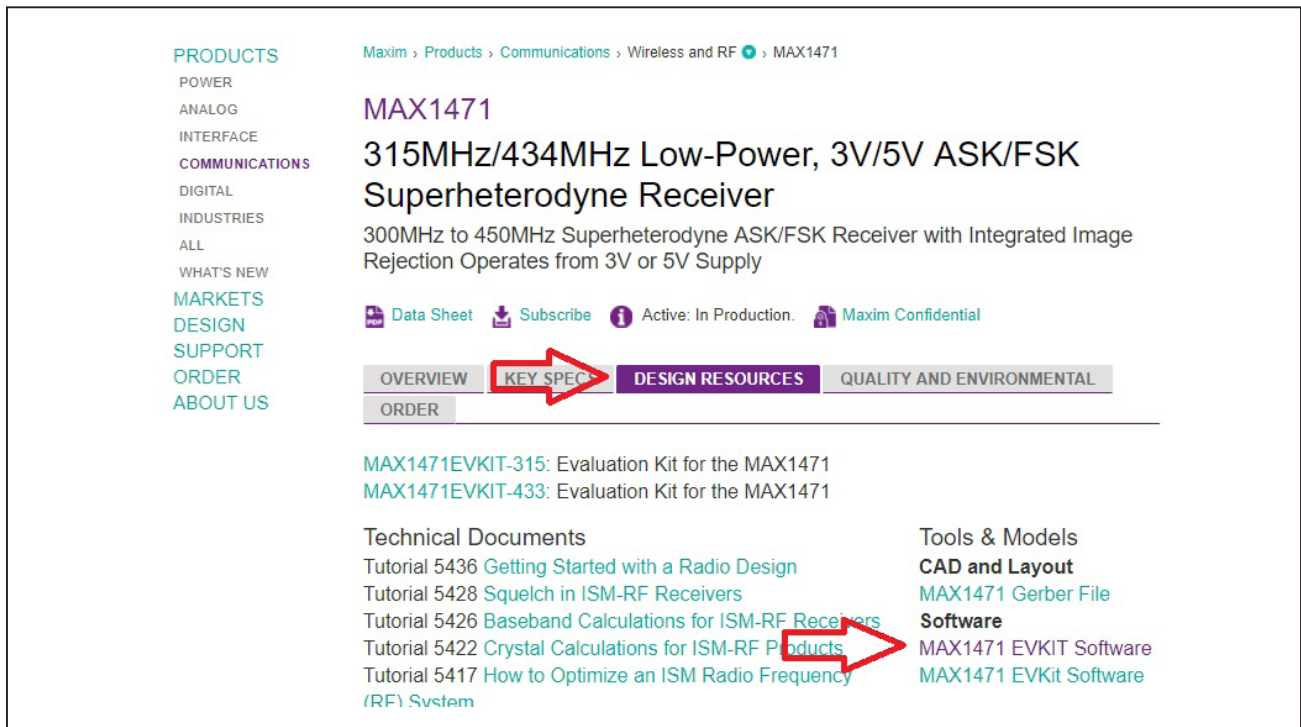

- 5) Click the file link on the software landing page to download the MAX1471 EV kit package.

DESIGN
ORDER
SUPPORT
ABOUT US

EV KIT SOFTWARE

Don't see your EV kit software here? Please use the Site Search to go directly to the EV kit or IC product folder page, and you'll find it on the Design Resources tab.

MAX1471 EVKIT Software

Software Version: 1.1
Filename: 1471R11.ZIP (898KB)
Description:
Operating Systems Supported: Windows 98/2000/XP
Required Hardware: MAX1471EVCMOD2 (MAX1471EVKIT plus CMOD232)
Related Data Sheets: [MAX1471 Product folder](#)

Notes: Download and unzip file. Run install.exe to install program.

- 6) Review the Maxim software license agreement (SLA) and accept the terms by clicking on the **Accept** button.

maxim integrated.

PRODUCTS
SOLUTIONS
DESIGN
ORDER
SUPPORT
ABOUT US

Maxim > Design Support > Tools, Models, and Software > Applications Software > EV Kit Software

EV Kit Software - License Agreement Portal

MAXIM INTEGRATED PRODUCTS, INC.
SOFTWARE LICENSE AGREEMENT

The software you are about to access by clicking on "I Agree" is provided pursuant to this Software License Agreement ("Agreement"). By clicking on "I Agree," downloading, installing, or otherwise using the software, you are entering into and agree to and consent to be bound by all of the terms of this Agreement between you and Maxim Integrated Products, Inc. on behalf of itself and its affiliates and subsidiaries ("Maxim"), effective as of the date you click "I Agree" (the "Effective Date"). You represent and warrant that you are at least eighteen (18) years of age if you are a resident of the United States, or the age of majority in the jurisdiction of your residence. If you are accepting these terms on behalf of another person or a company or other legal entity, you represent and warrant that you have full authority to bind that person, company,

[Download Printable Version](#)

My contact information

Name:	Martin Stoehr
Company:	Maxim Integrated
Address1:	
Address2:	
Address3:	
City:	
State/Province:	
Postal:	
Country:	
Email:	
Phone1:	
Phone2:	
Fax:	

If the information above is incomplete or inaccurate, please visit the [My Maxim](#) site to update your contact information.

- 7) Save the EV kit distribution package to the desktop or other accessible location for later install.

Install the MAX1471EVKIT GUI Software

This software and firmware are available from the www.maximintegrated.com website. See the [Download the MAX1471EVKIT Software Package](#) section above for information on obtaining the latest firmware from Maxim.

This process takes less than 10 minutes after downloading the software, firmware, and driver package.

- 1) Download the ISMRadioGUISetup.msi to the PC.
- 2) Double-click the ISMRadioGUISetup.msi setup file and follow setup wizard prompts.
 - a) Click **Next**

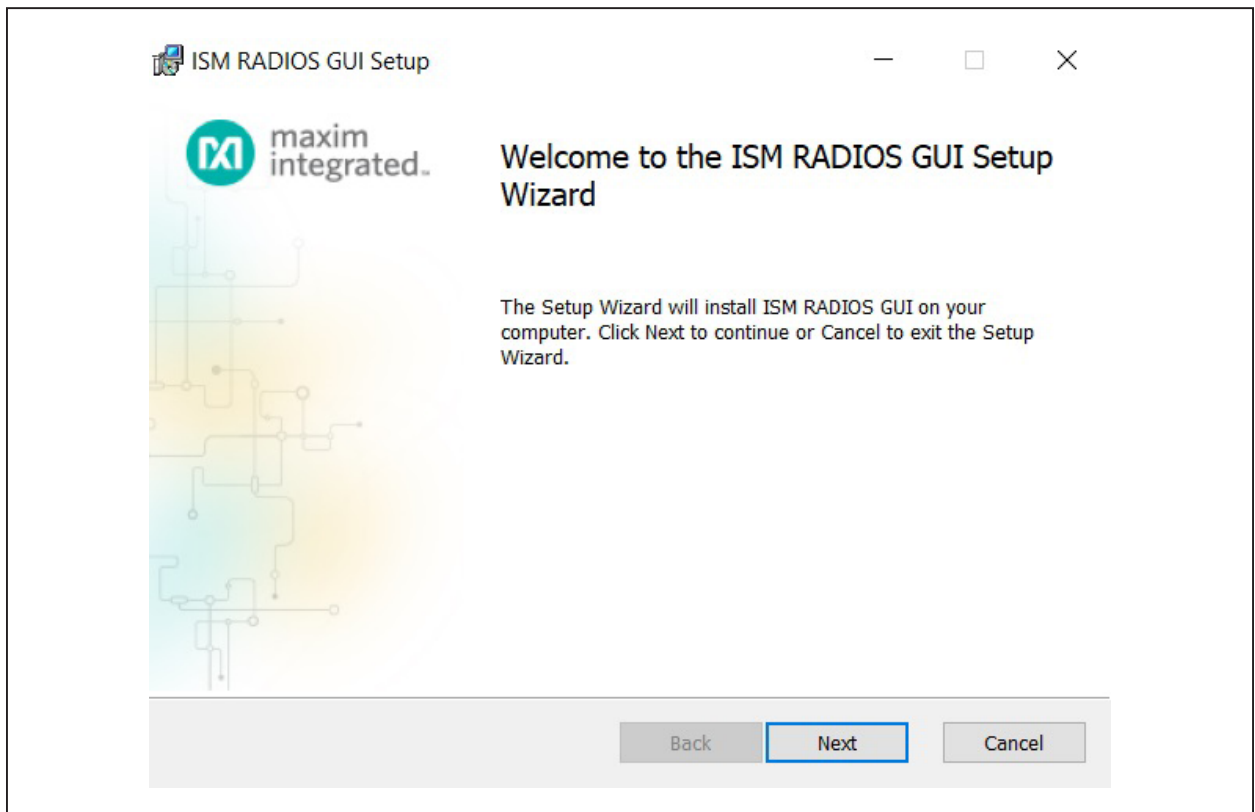

b) Use the default **Destination Folder** and click **Next**.

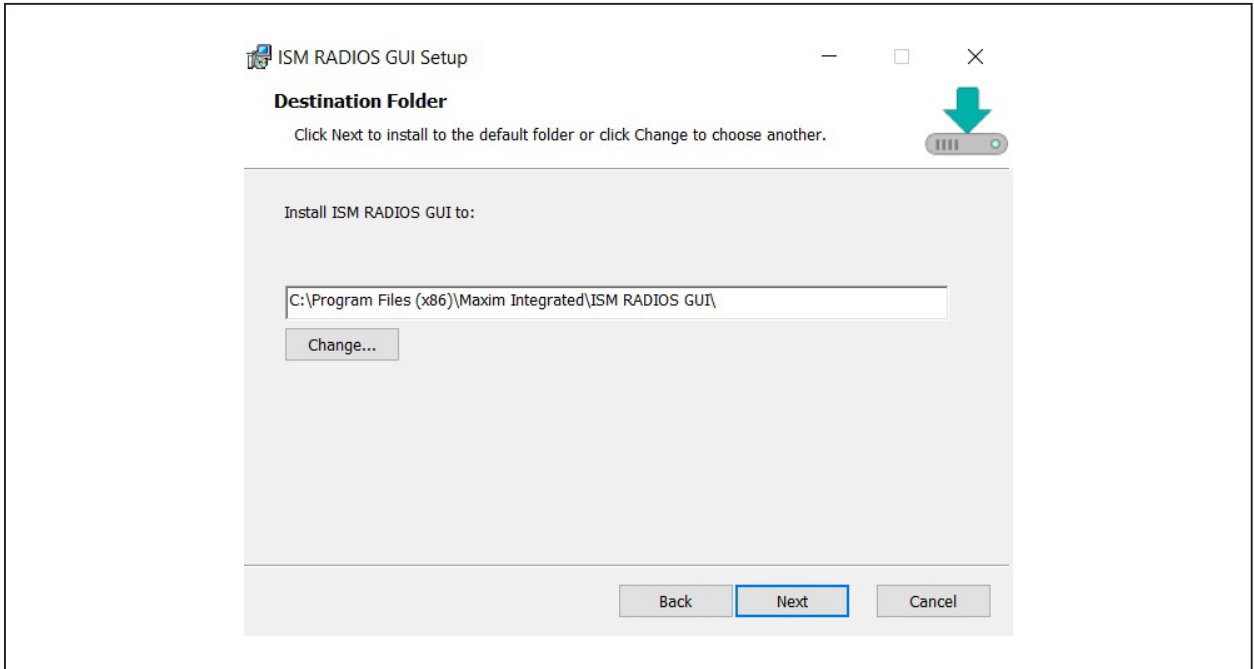

c) Install the software by clicking the **Install** button.

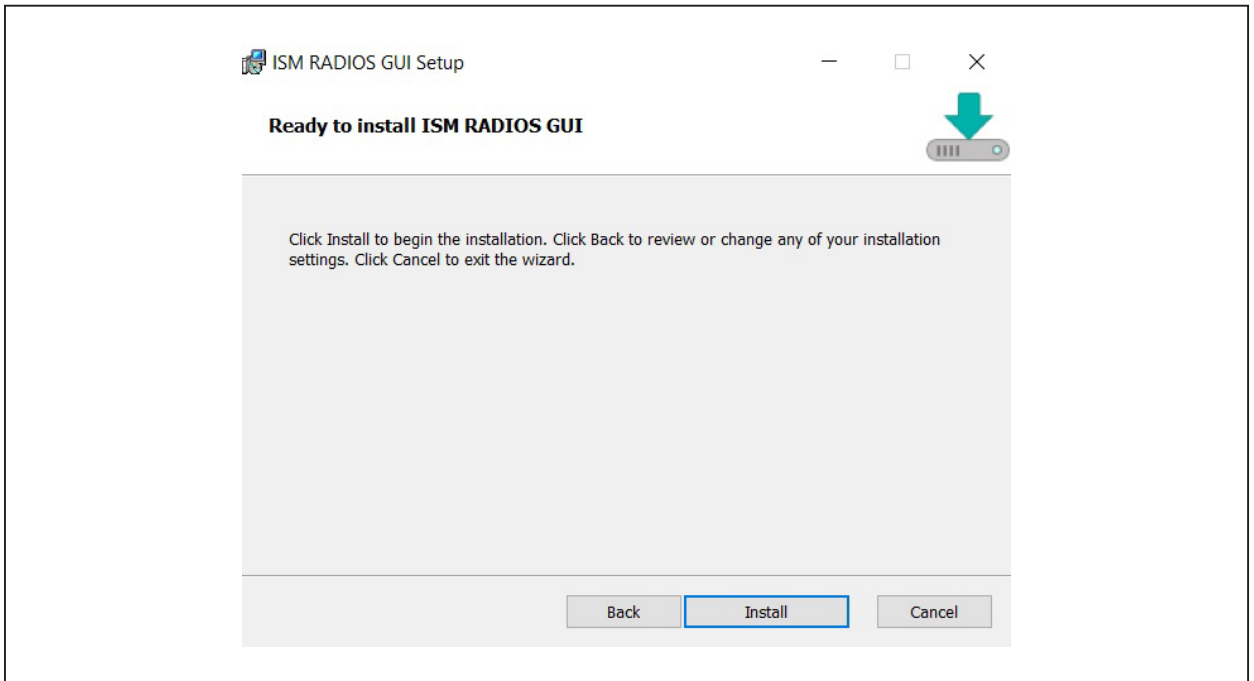

- d) Click **Finish** when the setup process is complete.

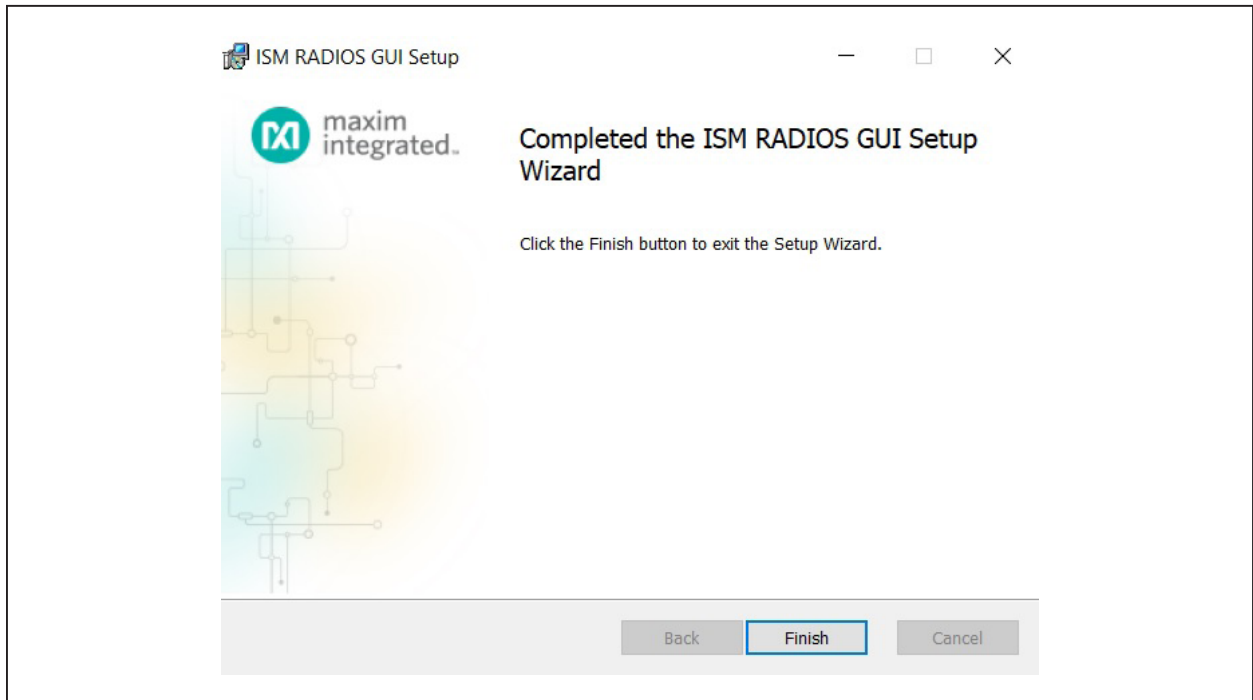

Program the MAX32630FTHR Board with the MAX1471 Firmware

This software and firmware are available from the www.maximintegrated.com website. See the [Download the MAX1471EVKIT Software Package](#) section above for information on obtaining the latest firmware from Maxim.

- 1) Connect the MAX32630FTHR to the MAX32625PICO.
 - a) Use the fine pitch 10pin ribbon cable to connect the boards from the SWD (J3) header on the MAX32625PICO to J4 on the MAX32630FTHR.

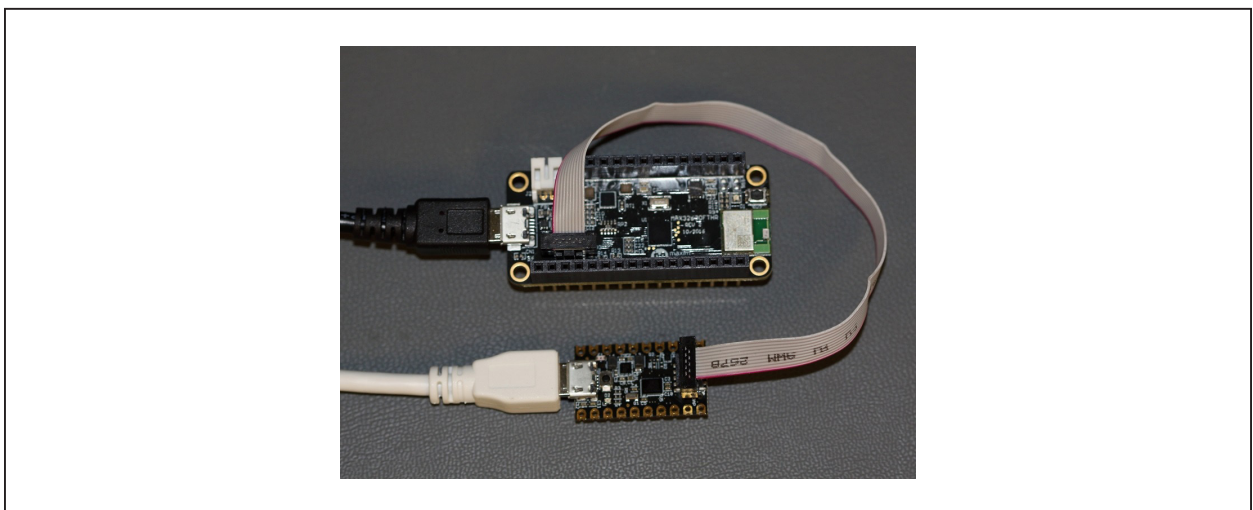

MAX32625PICO DAPLINK

- 2) Connect the MAX32630FTHR to a power source.
 - a) Use a micro-B USB cable to connect the MAX32630FTHR board to a suitable power source (no USB connectivity is required). [The black USB cable in the photos.] Alternatively, power the board from a charged battery and turn it on by pressing the power/reset button next to the battery connector. The board turns on automatically when powered from the USB supply.
 - b) The status LED on the FTHR board is lit a steady red.
- 3) Connect the MAX32625PICO to a PC.
 - a) Use a micro-B USB cable to connect the MAX32625PICO to a PC, through the USB connector. [The white USB cable in the photos.]

- a) The FTHR board LED shuts off and the LED on the MAX32625PICO slowly flashes red as the FTHR board is being programmed.
 - b) Once the programming is complete, the MAX32625PICO USB drive disconnects from the PC and reconnects as a USB drive again.
 - c) If the programming was successful, the contents of the MAX32625PICO USB drive includes a DETAILS.TXT file. If an ERROR.TXT file exists on the drive, check that the FTHR board had power during the programming process and repeat steps 3 and 4.
- 5) To ready the FTHR board for use, disconnect the MAX32625PICO board (ribbon cable) and press the **Reset** button on the FTHR board or disconnect the FTHR board from the USB power supply.
- a) When the Reset Button is pressed, the micro-controller restarts and the newly programmed application begins to run, or disconnects and reconnects the USB cable if using a PC for power.



Windows 7/10 Example

- b) The status LED on the DAPLINK board blinks red when connecting.
 - c) After a few seconds of activity, the PC recognizes the DAPLINK as a standard USB drive.
- 4) Drag and drop or save the ISM_Radio_fw.bin program binary to the Mbed or DAPLINK USB Drive.

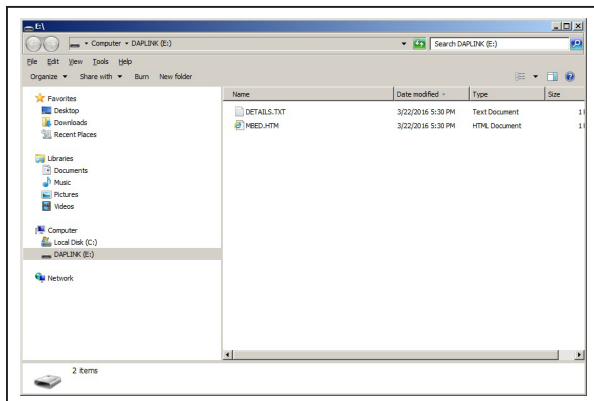

The latest information and these firmware update instructions can be found on the MAX32630FTHR board Mbed web site: <https://os.mbed.com/platforms/MAX32630FTHR/> or by visiting the Mbed home page (<https://www.mbed.com/>) and searching for the MAX32630FTHR.

If you do not have a Mbed account, choose Signup, and create the Mbed account. Otherwise, log in with your normal username and password. This gives an access to the website, tools, libraries, and documentation.

From: <https://os.mbed.com/teams/MaximIntegrated/wiki/MAX32625PICO-Firmware-Updates> note that the MAX32625PICO hardware supports multiple Mbed platforms, and the firmware needs to match the platform you that are using to enable all the features. The virtual serial port and CMSIS-DAP debug adapter is universal, but the drag-and-drop programming must match the target platform being programmed. To update the firmware, you need to put the board in maintenance mode and copy the new firmware image to the board. To put the board in maintenance mode, you need to hold the button while the board is being connected to the computer at the HDK connector. This activates maintenance mode, and the board appears to the computer as a thumb drive named MAINTENANCE. Drag and drop the new image onto the MAINTENANCE drive, and the board installs the new firmware. When the update is complete, the disk disconnects and reappear as a thumb drive named DAPLINK. There are links to the firmware images below.

Note: The board can be sensitive to excess loading on the crystal, which could prevent it from entering maintenance mode. Hold the board by the edges when entering maintenance mode. It can be easier to hold the button while inserting the USB cable at the computer end, rather than trying to insert the cable into the micro USB connector.

Load the matching HDK image for the platform that programs for drag-and-drop programming to work. For the MAX32630FTHR DAPLINK image:

https://os.mbed.com/media/uploads/switches/max32620_daplink_max32630fthr.bin

Update the MAX32630FTHR Board Driver

The required driver is available from the www.maximintegrated.com website. See the [Download the MAX1471EVKIT Software Package](#) section above for information on obtaining the latest driver from Maxim.

- 1) Connect the MAX32630FTHR to the PC's USB port.
- 2) In **Device Manager**, right click Other devices → CDC Device or **mbed Composite Device**.

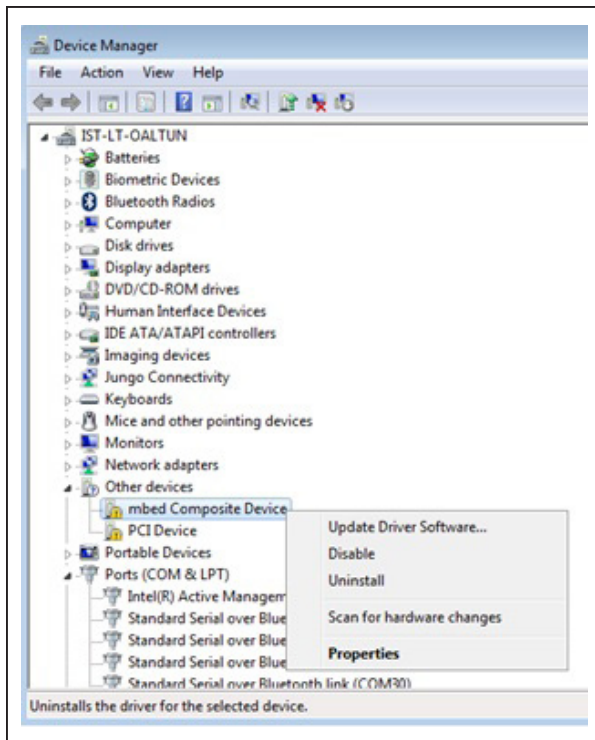

- 3) Click the **Update Driver Software** then select **Browse my computer for driver software**.

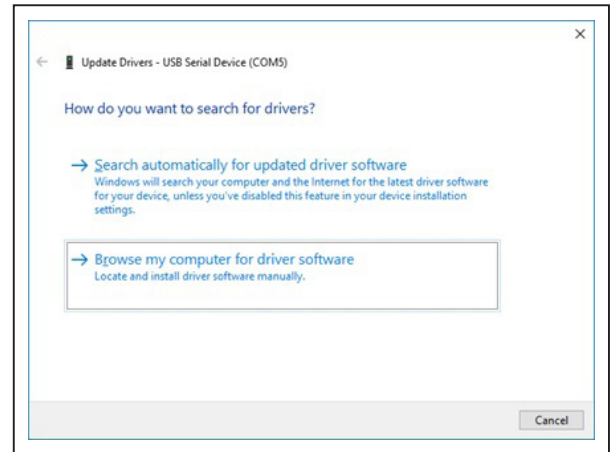

- 4) Select the **Let me pick from a list of available drivers on my computer**.

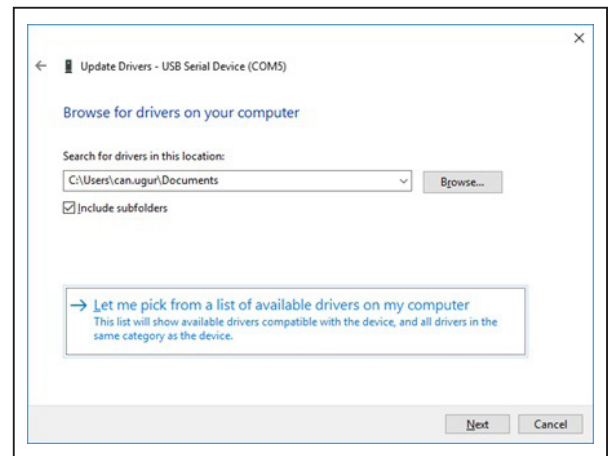

5) On a Windows 10 operating system, click the **Have Disk...** button.

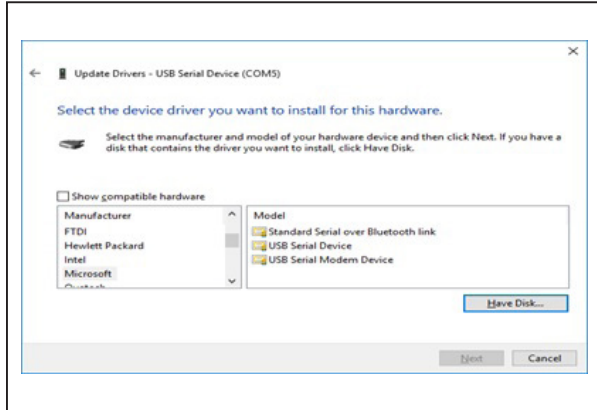

Windows 10: Have Disk... button

7) Click the **Next** button.

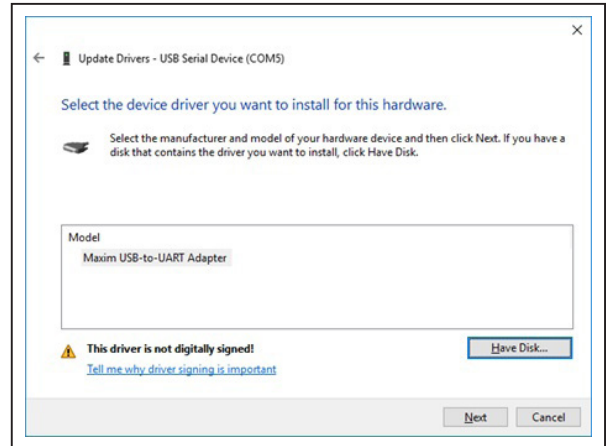

6) Browse the path of the driver folder and for Windows 10, click the **OK** button.

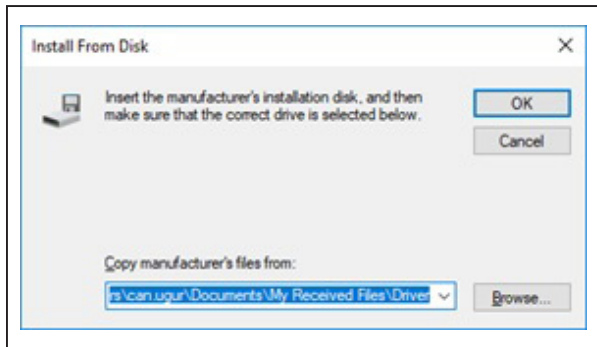

Windows 10: browse to the path and click OK

8) Ignore the warnings and click **Install...**

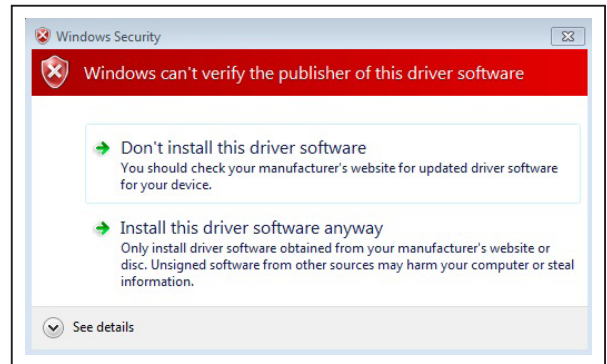

Windows 10 unverified publisher warning

Appendix II—Hardware Modifications

PMOD Header Interface

The MAX1471 EV kit provides a PMOD-compatible header footprint providing yet another built-in interface to the receiver. The H3 connector can be populated with a 6-pin, 100mil, right-angle header such as a SAMTEC TSW-106-25-T-S-RA, allowing direct connections to the CSB, DIO, SCLK, Ground, and VDD lines.

The PMOD interface can be used in combination with the Maxim MAX32600MBED kit and the MAXREFDES72# Arduino Uno R3 to PMOD shield adaptor. When using the PMOD interface to supply the MAX1471 EV kit with power, make sure to connect the J4 jumper between pins 2-3.

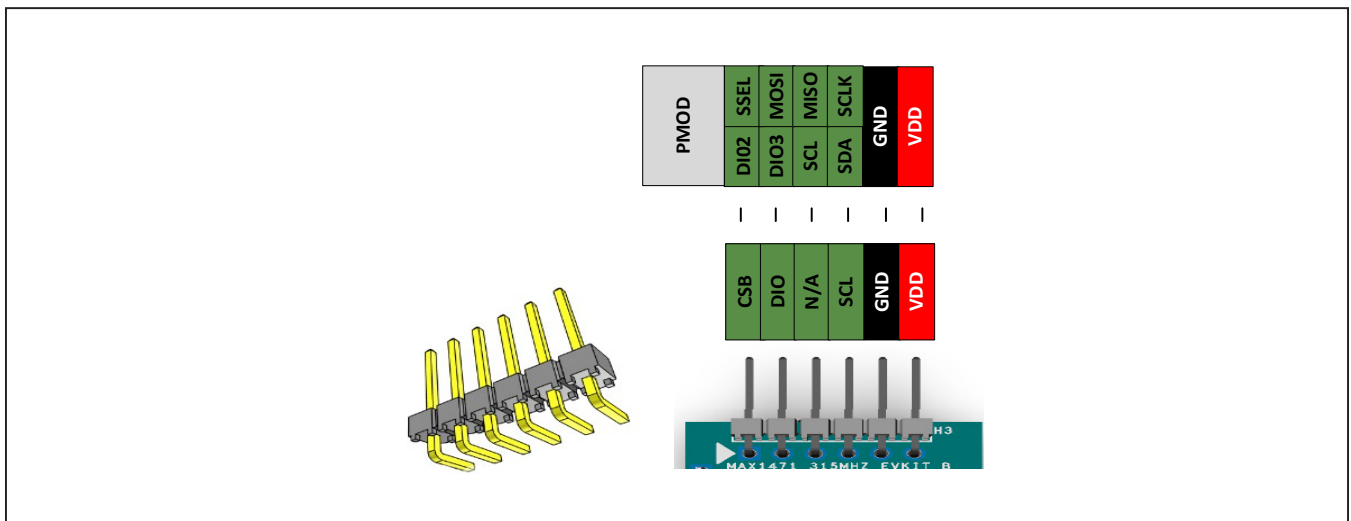
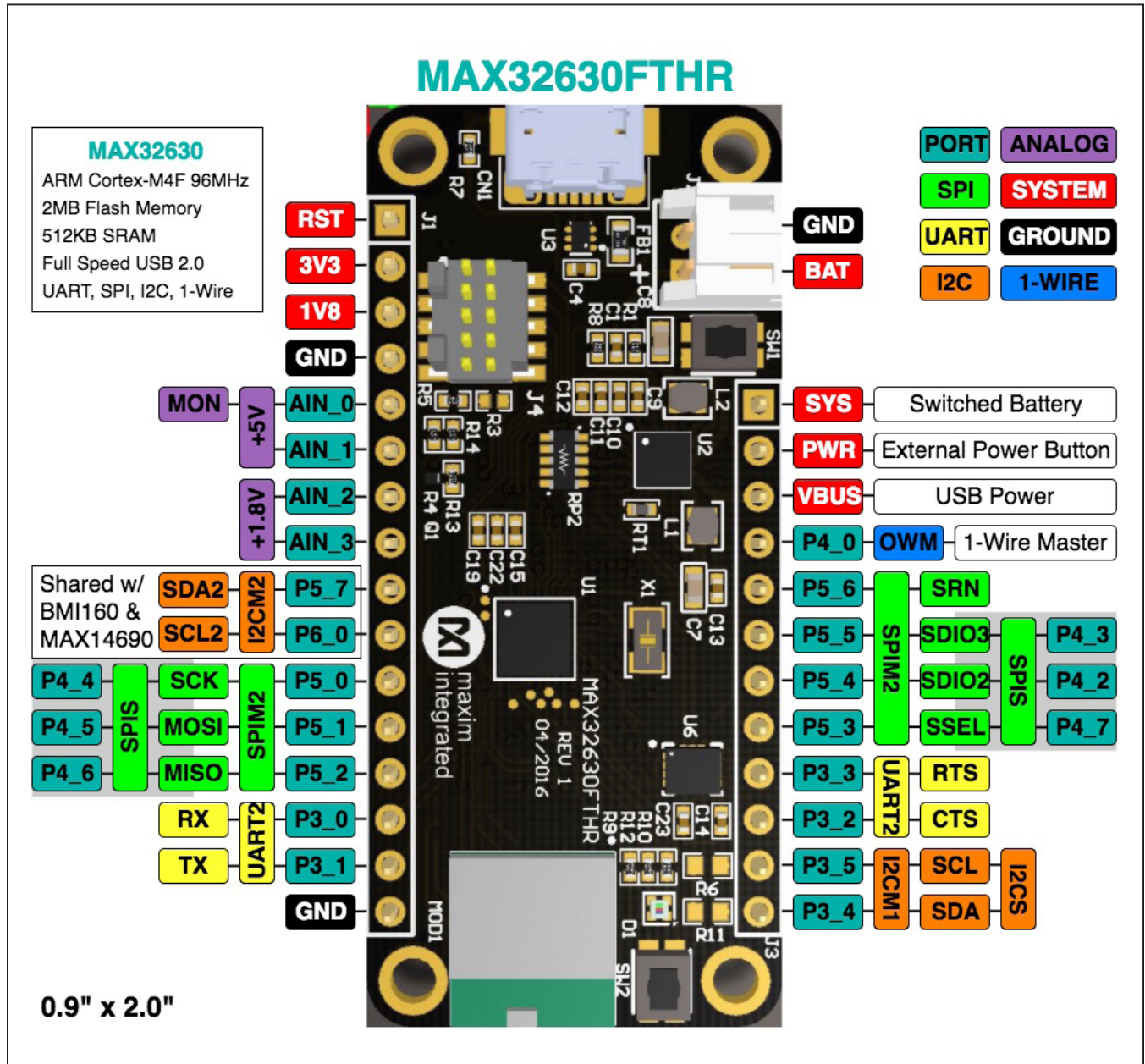

Figure A2-1. MAX1471EV Kit PMOD Interface

MAX32630FTHR

Arm Cortex-M4 processor with FPU rapid development platform.



MAX1471 EV Kit Bill of Materials

ITEM	REF_DES	DNI/DNP	QTY	MFG PART #	MANUFACTURER	VALUE	DESCRIPTION
1	ADATA	-	1	5116	KEYSTONE	N/A	TEST POINT; PIN DIA=0.1IN; TOTAL LENGTH=0.31IN; BOARD HOLE=0.04IN; GREEN; PHOSPHOR BRONZE WIRE SILVER PLATE FINISH;
2	C1, C2, C14, C15, C19, C20, C23, C29-C33	-	12	C0402C103K5RAC; GRM155R71H103KA88; C1005X7R1H103K050BE; C105B103KB5NNN	KEMET;MURATA;TDK; SAMSUNG ELECTRONIC	0.01UF	CAPACITOR; SMT (0402); CERAMIC CHIP; 0.01UF; 50V; TOL=10%; TG=-55 DEGC TO +125 DEGC; TC=X7R
3	C3	-	1	C0402C0G500-151JNP; GCM1555C1H151JA16	VENKEL LTD.;MURATA	150PF	CAPACITOR; SMT (0402); CERAMIC CHIP; 150PF; 50V; TOL=5%; TG=-55 DEGC TO +125 DEGC; TC=C0G
4	C4	-	1	C0402C331J5GAC; GRM1555C1H331JA01	KEMET;MURATA	330PF	CAPACITOR; SMT (0402); CERAMIC CHIP; 330PF; 50V; TOL=5%; TG=-55 DEGC TO +125 DEGC; TC=C0G
5	C5, C27	-	2	GRM155R71C473KA01	MURATA	0.047UF	CAPACITOR; SMT (0402); CERAMIC CHIP; 0.047UF; 16V; TOL=10%; TG=-55 DEGC TO +125 DEGC; TC=X7R
6	C6, C26	-	2	CGA2B3X7R1H104K050BB; C1005X7R1H104K050BB; GRM155R71H104KE14; GCM155R71H104KE02; C1005X7R1H104K050BE	TDK;TDK;MURATA; MURATA;TDK	0.1UF	CAPACITOR; SMT (0402); CERAMIC CHIP; 0.1UF; 50V; TOL=10%; TG=-55 DEGC TO +125 DEGC; TC=X7R
7	C7, C8, C11	-	3	C0402C101J5GAC; NMC0402NPO101J; CC0402JRNPO9BN101; GRM1555C1H101JA01; C1005C0G1H101J050BA; CGA2B2C0G1H101J050BA	KEMET; NIC COMPONENTS CORP.; YAGEO PHICOMP; MURATA;TDK;TDK	100PF	CAPACITOR; SMT (0402); CERAMIC CHIP; 100PF; 50V; TOL=5%; TG=-55 DEGC TO +125 DEGC; TC=C0G
8	C9	-	1	GJM1555C1H1R0BB01	MURATA	1PF	CAP; SMT (0402); 1PF; +/-0.1PF; 50V; C0G; CERAMIC CHIP
9	C10	-	1	GRM1555C1H221FA01	MURATA	220PF	CAP; SMT (0402); 220PF; 1%; 50V; C0G; CERAMIC CHIP
10	C12	-	1	C0402C152K5RAC; GRM155R71H152KA01	KEMET;MURATA	1500PF	CAPACITOR; SMT (0402); CERAMIC CHIP; 1500PF; 50V; TOL=10%; TG=-55 DEGC TO +125 DEGC; TC=X7R
11	C21	-	1	C0402C0G500-560JNE; CC0402JRNPO9BN560; GCM1555C1H560JA16	VENKEL LTD; YAGEO PHICOMP; MURATA	56PF	CAPACITOR; SMT (0402); CERAMIC CHIP; 56PF; 50V; TOL=5%; TG=-55 DEGC TO +125 DEGC; TC=C0G
12	C22	-	1	C0402C121J5GAC; GCM1555C1H121JA16	KEMET;MURATA	120PF	CAPACITOR; SMT (0402); CERAMIC CHIP; 120PF; 50V; TOL=5%; TG=-55 DEGC TO +125 DEGC; TC=C0G
13	FDATA	-	1	5004	KEYSTONE	N/A	TEST POINT; PIN DIA=0.1IN; TOTAL LENGTH=0.31IN; BOARD HOLE=0.04IN; YELLOW; PHOSPHOR BRONZE WIRE SILVER PLATE FINISH;
14	GND	-	1	5011	KEYSTONE	N/A	TEST POINT; PIN DIA=0.125IN; TOTAL LENGTH=0.445IN; BOARD HOLE=0.063IN; BLACK; PHOSPHOR BRONZE WIRE SILVER PLATE FINISH;
15	GND1	-	1	5001	KEYSTONE	N/A	TEST POINT; PIN DIA=0.1IN; TOTAL LENGTH=0.31IN; BOARD HOLE=0.04IN; BLACK; PHOSPHOR BRONZE WIRE SILVER PLATE FINISH;
16	H1	-	1	PRPC016SFAN-RC	SULLINS ELECTRONICS CORP	PRPC016SFAN-RC	CONNECTOR; MALE; THROUGH HOLE; PRPC SERIES; STRAIGHT; 16PINS
17	H2	-	1	PRPC012SFAN-RC	SULLINS ELECTRONICS CORP	PRPC012SFAN-RC	CONNECTOR; MALE; THROUGH HOLE; PRPC SERIES; STRAIGHT; 12PINS
18	J4	-	1	PEC03SAAN	SULLINS	PEC03SAAN	CONNECTOR; MALE; THROUGH HOLE; BREAKAWAY; STRAIGHT; 3PINS
19	L1	-	1	LQW18AN56NJ00	MURATA	56NH	INDUCTOR; SMT (0603); WIREWOUND; 56NH; 5%; 0.36A
20	L2	-	1	LQW15AN16NG00	MURATA	16NH	INDUCTOR; SMT (0402); WIREWOUND CHIP; 16NH; TOL=+/-2%; 0.37A
21	R1, R2, R6, R7	-	4	CRCW0402100KFK; RC0402FR-07100KL	VISHAY;YAGEO	100K	RESISTOR; 0402; 100K; 1%; 100PPM; 0.0625W; THICK FILM
22	R3, R8	-	2	PNM0402E2502BS	VISHAY DALE	25K	RESISTOR; 0402; 25K OHM; 0.1%; 25PPM; 0.05W; THIN FILM
23	R4, R9, R11, R12, R14, R16, R17, R19	-	8	RC0402JR-070RL; CR0402-16W-000RT	YAGEO PHYCOMP; VENKEL LTD.	0	RESISTOR; 0402; 0 OHM; 5%; JUMPER; 0.063W; THICK FILM
24	RF_IN	-	1	142-0701-851	JOHNSON COMPONENTS	142-0701-851	CONNECTOR; END LAUNCH JACK RECEPTACLE; BOARDMOUNT; STRAIGHT THROUGH; 2PINS;
25	SU1	-	1	STC02SYAN	SULLINS ELECTRONICS CORP	STC02SYAN	TEST POINT; JUMPER; STR; TOTAL LENGTH=0.256IN; BLACK; INSULATION=PBT CONTACT=PHOSPHOR BRONZE; COPPER PLATED TIN OVERALL

MAX1471 EV Kit Bill of Materials (continued)

ITEM	REF_DES	DNI/DNP	QTY	MFG PART #	MANUFACTURER	VALUE	DESCRIPTION
26	U1	-	1	MAX1471ATJ+	MAXIM	MAX1471ATJ+	IC; RECV; 315MHZ/434MHZ LOW-POWER, 3V/5V ASK/FSK SUPERHETERODYNE RECEIVER; QFN32-EP 5X5
27	VDD	-	1	5010	KEYSTONE	N/A	TEST POINT; PIN DIA=0.125IN; TOTAL LENGTH=0.445IN; BOARD HOLE=0.063IN; RED; PHOSPHOR BRONZE WIRE SIL;
28	Y1	-	1	X503213225625MED4SI	YXC	13.225625MHZ	EVKIT PART -CRYSTAL; SMT; 3PF; 13.225625MHZ; +/-20PPM;
29	Y2	-	1	SFECF10M7EA00	MURATA	SFECF10M7EA00	FILTER; BNDPS; SMT; 10.7MHZ; 3DB BANDWIDTH=330KHZ
30	PCB	-	1	MAX1471433MHZ	MAXIM	PCB	PCB:MAX1471433MHZ
31	J1	DNI	1	PPPC161LFBN-RC	SULLINS ELECTRONICS CORP	PPPC161LFBN-RC	CONNECTOR; FEMALE; THROUGH HOLE; LFB SERIES; 2.54MM CONTACT CENTER; STRAIGHT; 16PINS
32	J2	DNI	1	PPPC121LFBN-RC	SULLINS ELECTRONICS CORP	PPPC121LFBN-RC	CONNECTOR; FEMALE; THROUGH HOLE; HEADER FEMALE; STRAIGHT; 12PINS
33	U2	DNI	1	MAX32630FTHR#	MAXIM	MAX32620FTHR#	EVKIT PART - MODULE; BOARD ASSEMBLY; THROUGH HOLE; RAPID DEVELOPMENT PLATFORM;
34	H3	DNP	0	TSW-106-25-T-S-RA	SAMTEC	TSW-106-25-T-S-RA	CONNECTOR; MALE; THROUGH HOLE; 0.025IN SQ POST HEADER; RIGHT ANGLE; 6PINS
35	R5, R10, R15, R18	DNP	0	RC0402JR-070RL; CR0402-16W-000RJT	YAGEO PHYCOMP; VENKEL LTD.	0	RESISTOR; 0402; 0 OHM; 5%; JUMPER; 0.063W; THICK FILM
36	R13	DNP	0	CRCW0402200KFK; RF73H1ELTP2003	VISHAY DALE; KOA SPEER ELECTRONICS	200K	RESISTOR; 0402; 200K; 1%; 100PPM; 0.0625W; THICK FILM
37	C16, C17	DNP	0	N/A	N/A	OPEN	PACKAGE OUTLINE 0402 NON-POLAR CAPACITOR
TOTAL			59				

MAX1471 EV Kit Schematics

MECHANICAL

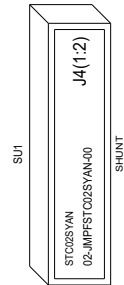
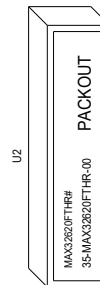
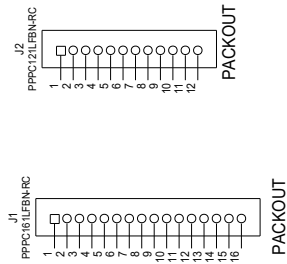

MAX1471 EV Kit Schematics (continued)

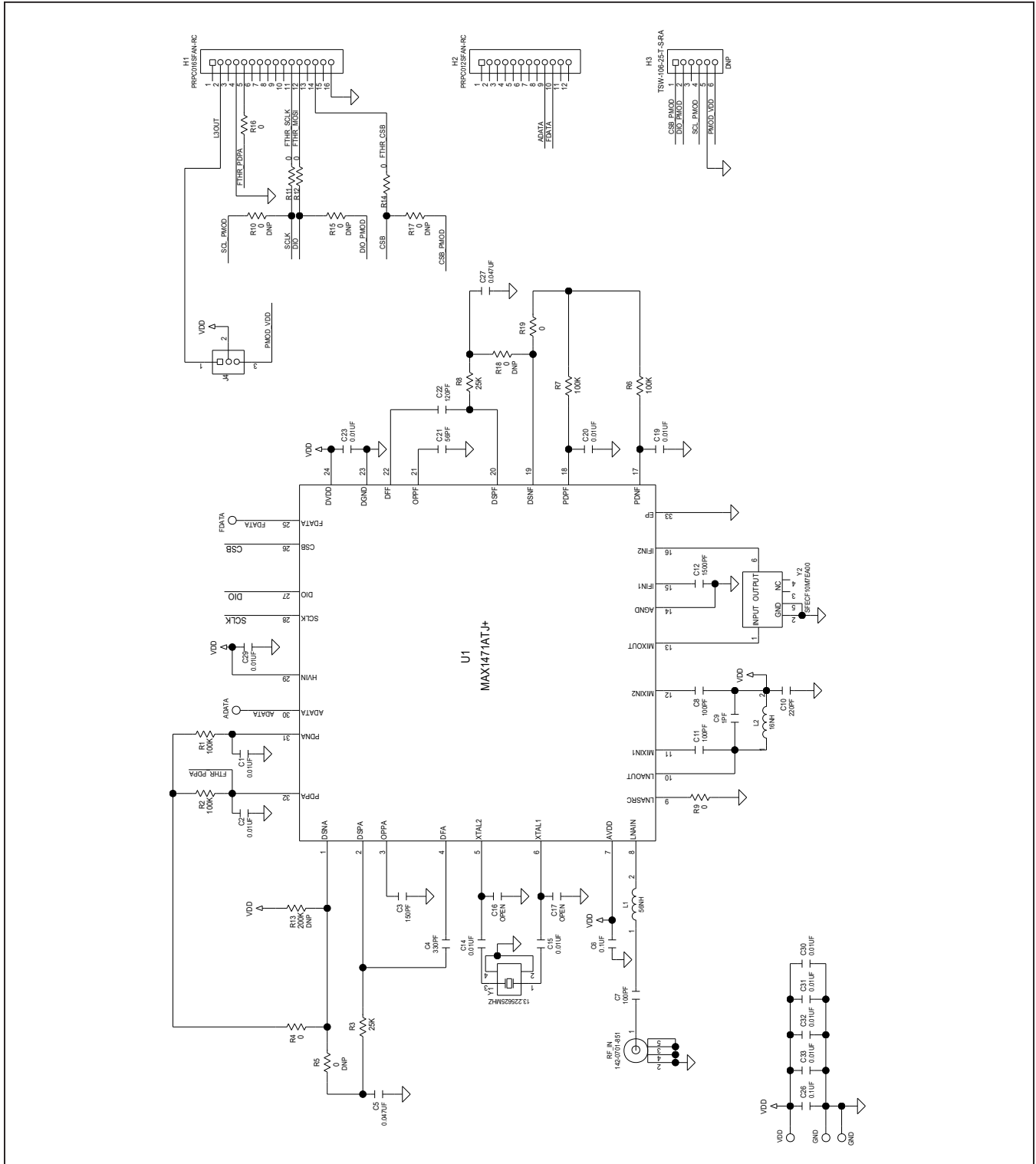

MAX1471 EV Kit PCB Layouts

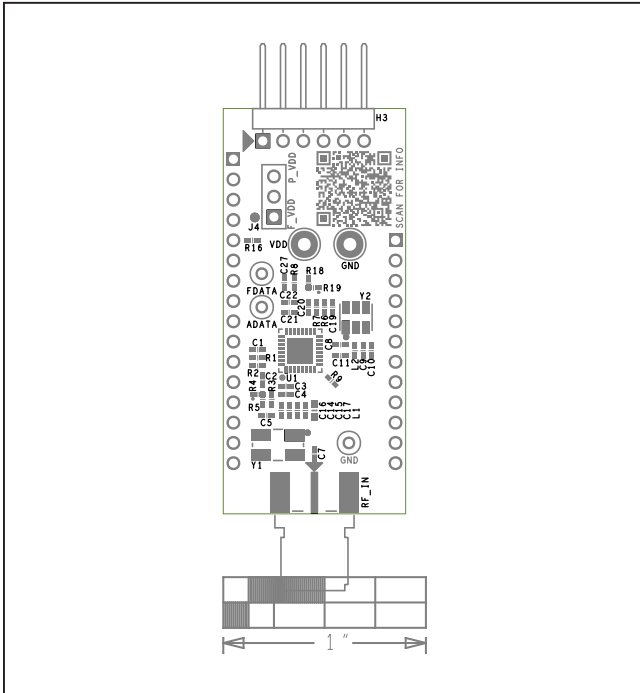

MAX1471 EV Kit Component Placement Guide—Top Silkscreen

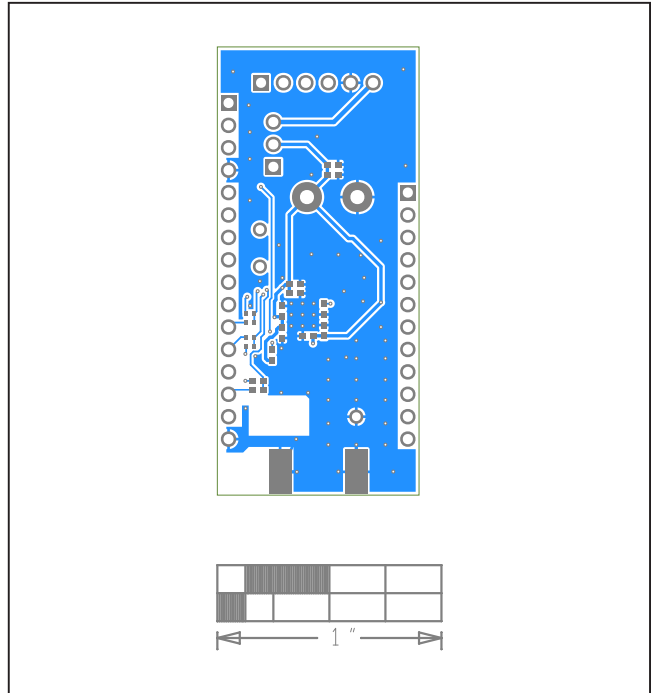

MAX1471 EV Kit PCB Layout—Bottom

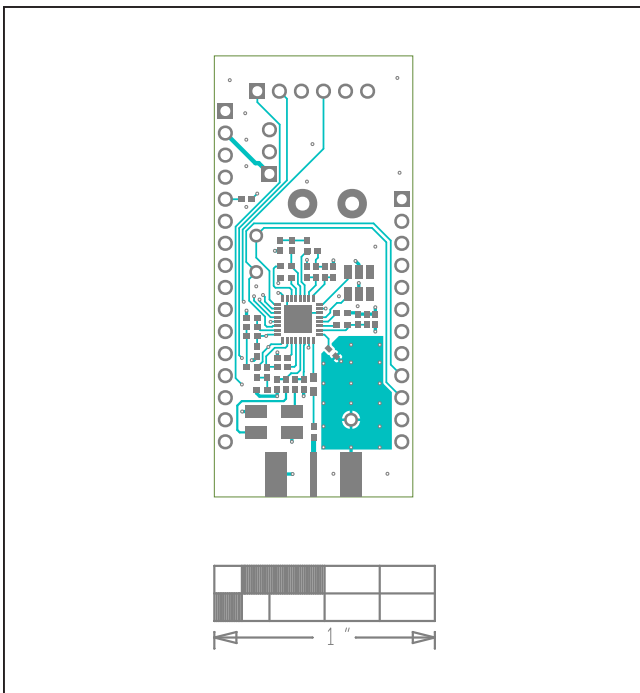

MAX1471 EV Kit PCB Layout—Top

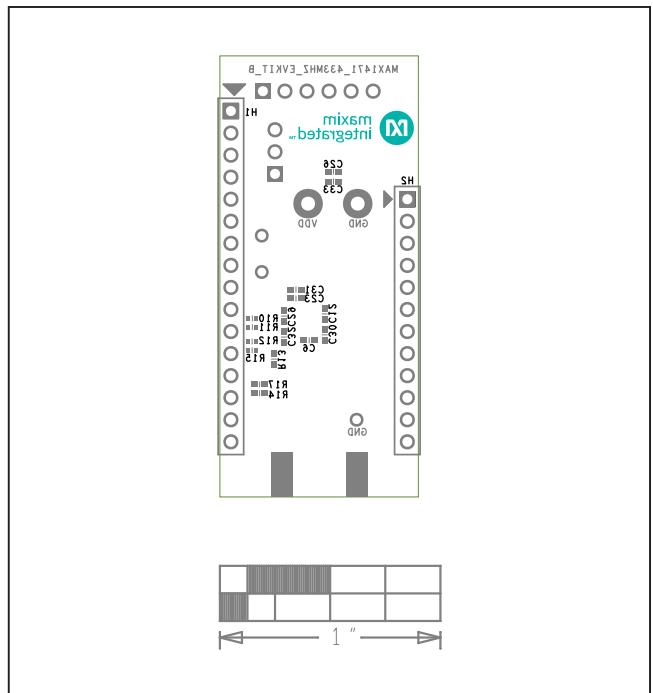

MAX1471 EV Kit PCB Layout—Bottom Silkscreen

Revision History

REVISION NUMBER	REVISION DATE	DESCRIPTION	PAGES CHANGED
0	9/16	Initial release	—
1	1/19	Adjusted text to correlate with component corrections, Corrected schematic component value to match the BOM table: C3, C4, C21, and C22	3, 11
2	10/20	Updated EV kit with a new hardware description	1–33

For pricing, delivery, and ordering information, please visit Maxim Integrated's online storefront at <https://www.maximintegrated.com/en/storefront/storefront.html>.

Maxim Integrated cannot assume responsibility for use of any circuitry other than circuitry entirely embodied in a Maxim Integrated product. No circuit patent licenses are implied. Maxim Integrated reserves the right to change the circuitry and specifications without notice at any time.