

General Description

The MAX14850 evaluation kit (EV kit) is a fully assembled and tested circuit board that demonstrates the functionality of the MAX14850 6-channel digital isolator in a 16-pin narrow body SO surface-mount package. The EV kit features an on-board isolated power supply, an RS-485 transceiver, and an RS-232 transceiver. The EV kit is powered from a single 5V supply.

Features

- Operates from a Single 5V Supply
- On-Board Isolated RS-485 and RS-232 Transceivers for Easy Testing
- 600V_{RMS} Isolation for 60s
- Proven PCB Layout
- Fully Assembled and Tested

Ordering Information appears at end of data sheet.

Quick Start

Required Equipment

- MAX14850 EV kit
- 5V DC power supply or USB cable with a micro-B connector
- Signal/function generator
- Oscilloscope

Startup Procedure

The EV kit is fully assembled and tested. Follow the steps below to verify board operation:

- 1) Connect the DC power supply between the EV kit's +5V and GNDA test points.
- 2) Turn on the DC power supply and set it to 5V, then enable the power-supply output.

Note: It is also possible to power the EV kit with a standard USB port. To do so, connect the micro-B end of a USB cable into P1 on the board. Connect the A end of the USB cable into the USB port.

- 3) Verify that the PWR (LED1) and RS-485 (LED3) LEDs are on.
- 4) Connect a function/signal generator to the INA2 test point (TP3) and set the output to a 1MHz 0 to 5V square wave. Verify that A and B outputs (TP16 and TP15, respectively) switch as the signal toggles.

Detailed Description of Hardware

The MAX14850 EV kit is a fully assembled and tested circuit board for evaluating the MAX14850 6-channel digital isolator (U1) in a 16-pin narrow body SO package. The EV kit has been designed to allow for evaluating the MAX14850 alone or in a standard RS-485 or RS-232 configuration. The EV kit is powered from a single 5V.

External Power Supply

Power on the EV kit is derived from a single 5V source. Connect an external supply to the 5V and GNDA test points or connect a micro-B USB cable to the on-board P1 connector to generate the 5V.

An on-board MAX256 H-bridge driver circuit (U3) and a MAX8881 LDO (U2) generate an isolated 3.3V supply to power the secondary (B) side of the board. The 3.3V supply powers the MAX4948 switch (U5) and the RS-485 and RS-232 interface (U7) ICs.

Mode Selection

The EV kit has been designed to allow for evaluating the U1 IC alone or in a standard interface configuration (i.e., RS-485, RS-232, SPI, or I²C). Jumper JU1 enables/disables the U5 switch. Disable the U5 switch to evaluate the U1 IC alone or in an SPI or I²C configuration. Enable

U5 to evaluate the U1 IC in an RS-485 or RS-232 configuration. See [Table 1](#) for jumper settings.

Evaluating the MAX14850 in a Standalone Configuration

Disable the U5 IC to evaluate the U1 IC alone. VCCA and VCCB remain unchanged (+5V and +3.3V, respectively) in this configuration, and the U5 IC remains powered. Do not apply a voltage higher than +3.3V relative to GNDB on any OUTB_, INB_, or I/OB_ pin when evaluating the U1 IC in standalone mode.

Evaluating the MAX14850 in an Isolated RS-485 Configuration

The EV kit uses a pushbutton switch to select between an RS-232 and an RS-485 interface. The U1 IC is connected to the on-board U7 RS-485 transceiver when LED3 is on. [Table 2](#) shows the U1 IC I/O connections for RS-485 mode.

The U1 IC level shifts the data and control signals and transmits them across the isolation barrier. The signals are then routed through the U5 switch to the U7 transceiver.

Transistors Q1 and Q2 are included to ensure high data rates through the U5 switch.

Table 1. EV Kit Connections for RS-485 and RS-232 Modes

JUMPER	SHUNT POSITION	DESCRIPTION	
		MAX4948 SWITCH	EVALUATION MODE
JU1	1-2	Disabled	MAX14850 alone
	2-3*	Enabled	RS-485 and RS-232 interface

*Default position.

Table 2. EV Kit A-Side Connections for RS-485 Interface Configuration

MAX14850 PIN	TEST POINT CONNECTION	CONNECTION TO THE RS-485 TRANSCEIVER
OUTA1	TP8	RO
OUTA2	TP9	GND
INA1	TP3	DI
INA2	TP5	Unconnected
I/OA1	TP11	\overline{RE}
I/OA2	TP13	DE

A 120Ω resistor (R18) differentially terminates the A and B data lines of the U7 IC. Resistors R16 and R19 are not installed, but are available for testing custom termination.

Figure 1 is a simplified schematic showing the connections for evaluating the U1 IC in an isolated RS-485 circuit. The U1 IC’s high-speed unidirectional channels are used for data channels DI and RO. Bidirectional channels are demonstrated on the enable lines (DE and RE), where lower speed is acceptable. Note that deasserting RE three-states the RO output of the transceiver only; it does not three-state the I/O_1 channel of the U1 IC.

Assert both DE and RE to loop the DI input signal back to the isolated RO output, allowing the DI source and RO monitor to share a common ground (GNDA) while the RS-485 transceiver is unconnected. Note that the signal delays between DI and RO are equivalent to an RS-485 link using a U1 IC isolated transceiver at each end. The total delay includes two U1 IC delays plus the delay from both the RS-485 transmitter and the RS-485 receiver. Test the isolator with changing ground potentials by connecting the GND of a signal generator to GNDA and the output of the generator to GNDB.

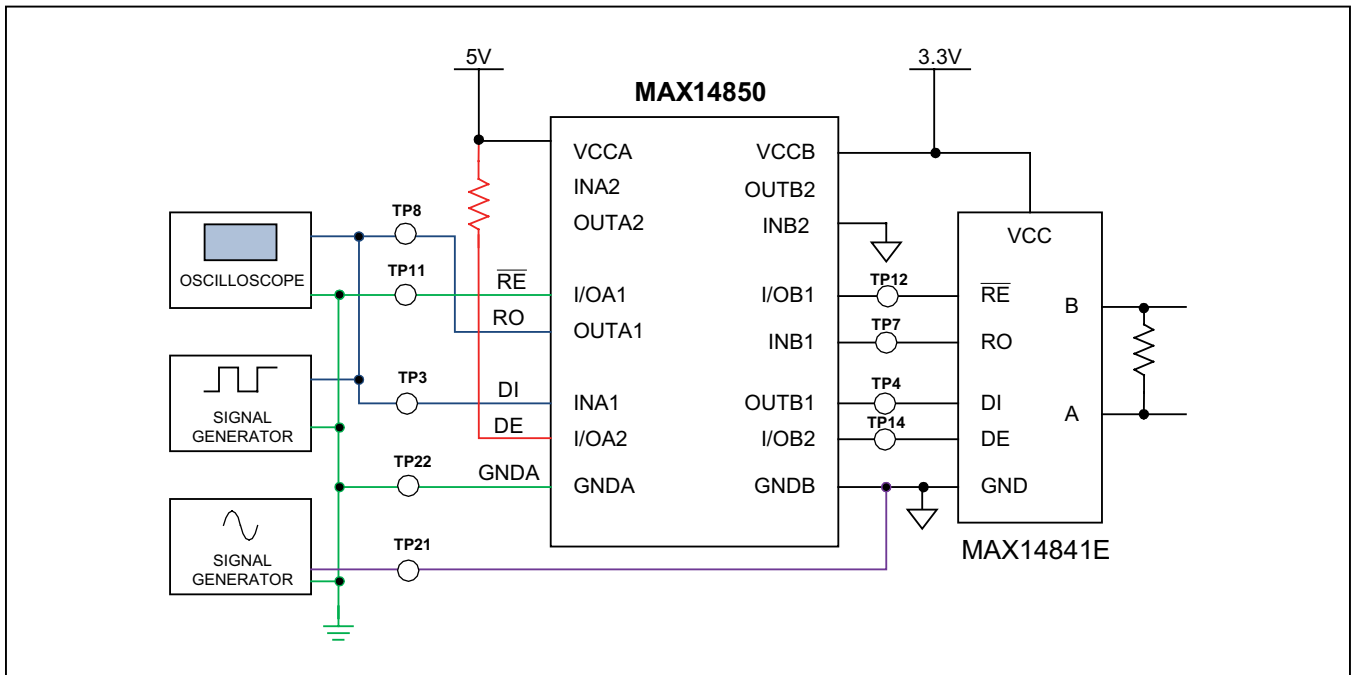

Figure 1. Simplified Connection Diagram for Evaluating the MAX14850 in an Isolated RS-485 Configuration

Evaluating the MAX14850 in an Isolated RS-232 Configuration

The U1 IC is connected to the on-board MAX13235E transceiver (U8) when LED2 is on. Table 3 shows the U1 IC's I/O connections for RS-232 mode.

The U8 IC is a low-voltage interface, RS-232 transceiver capable of data rates up to 3Mbps. The U1 IC level shifts the data and control signals and transmits them across the isolation barrier. The signals are then routed through the U5 switch to the U8 transceiver.

Figure 2 is a simplified schematic showing the connections for evaluating the U1 IC in an isolated RS-232 circuit.

Connect the RX and TX signals on the peripheral unit together to loop the signal back to the isolated input, allowing the input source and output monitor to share a common ground (GNDA) while the RS-232 transceiver is floating.

Test the isolator with changing ground potentials by connecting the GND of a signal generator to GNDA and the output of the generator to GNDB.

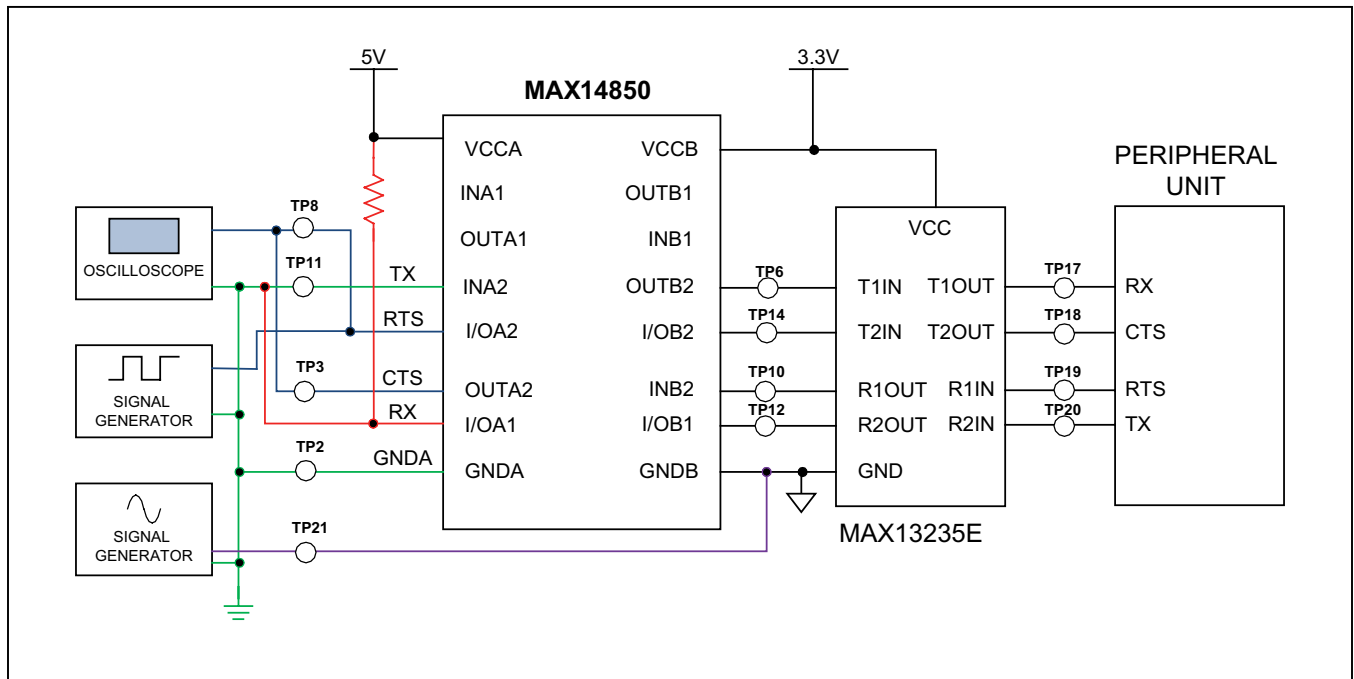

Figure 2. Simplified Connection Diagram for Evaluating the MAX14850 in an Isolated RS-232 Configuration

Table 3. EV Kit A-Side Connections for RS-232 Interface Configuration

MAX14850 PIN	TEST POINT CONNECTION	CONNECTION TO THE RS-232 TRANSCEIVER
OUTA1	TP8	Unconnected
OUTA2	TP9	R1OUT
INA1	TP3	Unconnected
INA2	TP5	T1IN
I/OA1	TP11	R2OUT
I/OA2	TP13	T2IN

Evaluating the MAX14850 in an Isolated I²C Configuration

The U1 IC can be used to transmit signals on isolated I²C serial buses. Set the EV kit in stand-alone mode (see Table 1) and connect signals as shown in Table 4 to evaluate isolated I²C operation.

Figure 3 is a simplified schematic showing the connections for evaluating the U1 IC in an isolated I²C interface. The U1 IC level shifts the data and clock signals and transmits them across the isolation barrier.

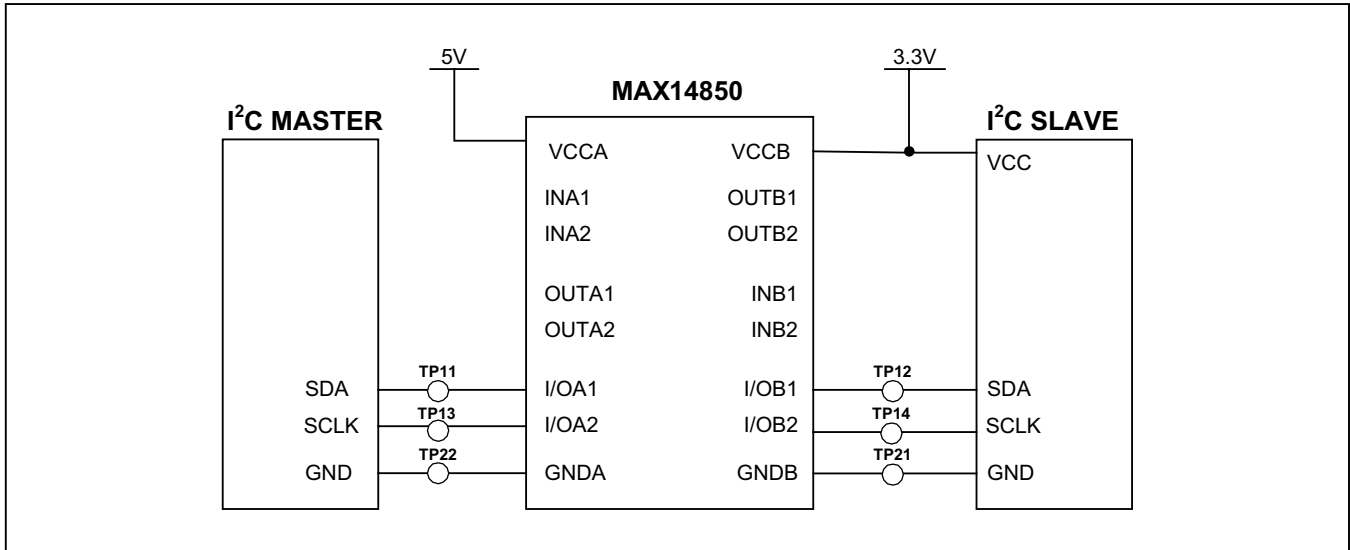

Figure 3. Simplified Connection Diagram for Evaluating the MAX14850 in an Isolated I²C Configuration

Table 4. EV Kit Connections for Isolated I²C Evaluation

MAX14850 PIN	TEST POINT CONNECTION	DESCRIPTION
OUTA1	TP8	Unconnected
OUTA2	TP9	Unconnected
INA1	TP3	Unconnected
INA2	TP5	Unconnected
I/OA1	TP11	SDA
I/OA2	TP13	SCLK

Evaluating the MAX14850 in an Isolated SPI/MICROWIRE® Configuration

The U1 IC can be used to transmit signals on isolated SPI/MICROWIRE serial buses. Set the EV kit in stand-alone mode (see [Table 1](#)) and connect the signals as shown in [Table 5](#) to evaluate isolated SPI/MICROWIRE operation.

[Figure 4](#) is a simplified schematic showing the connections for evaluating the U1 IC in an isolated SPI/MICROWIRE interface. The U1 IC level shifts the data and clock signals and transmits them across the isolation barrier.

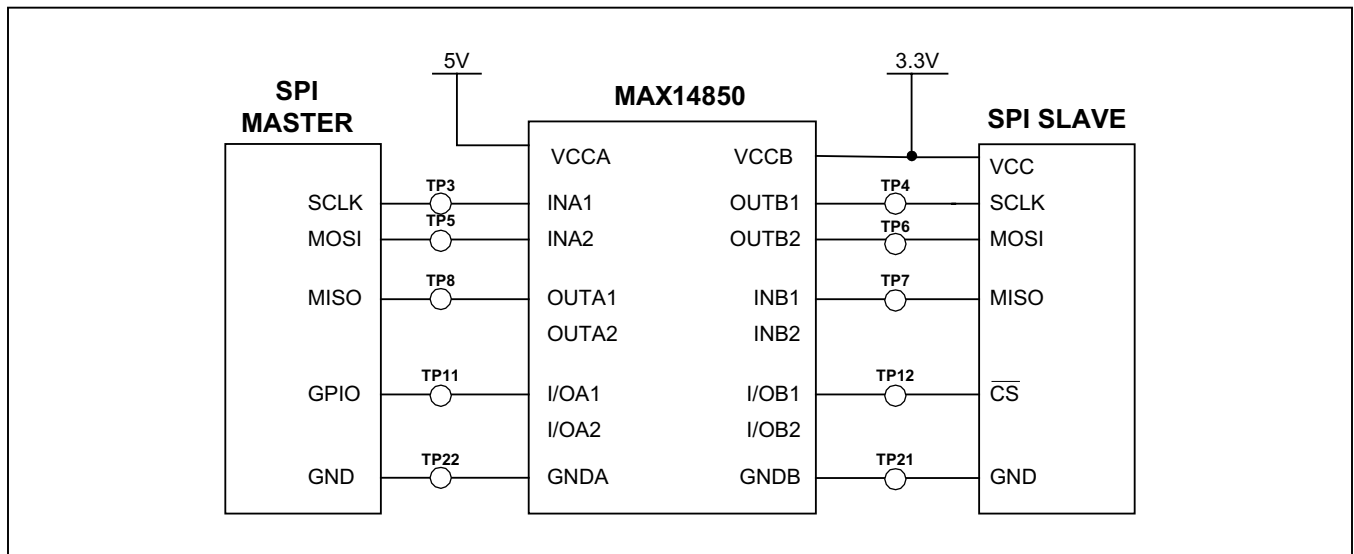

Figure 4. Simplified Connection Diagram for Evaluating the MAX14850 in an Isolated SPI Configuration

Table 5. EV Kit Connections for Isolated SPI/MICROWIRE Evaluation

MAX14850 PIN	TEST POINT CONNECTION	DESCRIPTION
INA1	TP3	SCLK
INA2	TP5	MOSI
OUTA1	TP8	MISO
OUTA2	TP9	Unconnected
I/OA1	TP11	\overline{CS}
I/OA2	TP13	Unconnected

MICROWIRE is a registered trademark of National Semiconductor Corp.

Component Suppliers

SUPPLIER	WEBSITE
Fairchild Semiconductor	www.fairchildsemi.com
Murata Electronics	www.murata.com
Omron	www.omron.com/ecb/
ON Semiconductor	www.onsemi.com
Pulse	www.pulseelectronics.com

Note: Indicate that you are using the MAX14850 when contacting these component suppliers..

Component List, PCB Layout, and Schematics

- [MAX14850 EV BOM](#)
- [MAX14850 EV PCB Layout](#)
- [MAX14850 EV Schematics](#)

Ordering Information

PART	TYPE
MAX14850EVKIT#	EV Kit

#Denotes RoHS compliant.

Revision History

REVISION NUMBER	REVISION DATE	DESCRIPTION	PAGES CHANGED
0	10/15	Initial release	—

For information on other Maxim Integrated products, visit Maxim Integrated's website at www.maximintegrated.com.

Maxim Integrated cannot assume responsibility for use of any circuitry other than circuitry entirely embodied in a Maxim Integrated product. No circuit patent licenses are implied. Maxim Integrated reserves the right to change the circuitry and specifications without notice at any time.

DESIGNATION	QTY	DESCRIPTION
C1, C4	2	4.7 μ F \pm 10%, 10V X7R ceramic capacitors (0805) Murata GRM21BR71A475K
C2	1	0.47 μ F \pm 10%, 16V X7R ceramic capacitor (0603) Murata GCM188R71C474KA55D
C3	1	1 μ F \pm 10%, 25V X7R ceramic capacitor (0805) Murata GRM219R71E105K
C5–C10	6	0.1 μ F \pm 10%, 50V X7R ceramic capacitors (0603) Murata GCM188R71H104K
C11–C16	6	0.22 μ F \pm 10%, 25V X7R ceramic capacitors (0603) Murata GRM188R71E224K
D1–D4	4	40V, 1A Schottky rectifiers (SOD-123) ON Semi MBR140SFT1G
LED1–LED3	3	Green LEDs (1206)
JU1	1	3-pin header
P1	1	USB micro-B connector
Q1, Q2	2	50V, 100mA PNP transistors (SOT23) Fairchild MMBT5087
R1	1	560 Ω \pm 5% resistor (0603)
R2	1	47k Ω \pm 5% resistor (0603)
R3, R4, R16, R19	0	Not installed, resistors (0603)
R5–R8	4	2k Ω \pm 5% resistors (0603)
R9, R10	2	330 Ω \pm 5% resistors (0603)
R11, R14	2	1k Ω \pm 5% resistors (0603)
R12, R15	2	100k Ω \pm 5% resistors (0603)
R13, R17	2	100 Ω \pm 5% resistors (0603)
R18	1	120 Ω \pm 5% resistor (0603)
SW1	1	Pushbutton switch
T1	1	1:1:1, 1500kV basic isolation transformer Pulse P0926
TP1	1	Red test point
TP2, TP21–TP23	4	Black test points
TP3–TP14	12	White test points
TP15–TP20	6	Yellow test points
U1	1	6-channel digital isolator (16 SO) Maxim MAX14850ASE+
U2	1	3.3V LDO (6 SOT23) Maxim MAX8881EUT33+
U3	1	Transformer driver (8 SO-EP*) Maxim MAX256ASA+
U4	1	Dual SPDT switch (10 μ MAX®) Maxim MAX4684EUB+
U5	1	Hex SPDT (24 TQFN-EP*) Maxim MAX4948ETG+
U6	1	Switch debouncer (6 SOT23) Maxim MAX16054AZT+
U7	1	RS-485 transceiver (8 SO) Maxim MAX14841EASA+
U8	1	RS-232 transceiver (20 TQFN-EP*) Maxim MAX13235EETP+
—	1	PCB: MAX14850 EVALUATION KIT

*EP = Exposed pad.

MAX14850 EVKIT	
P/N: EPCB14850	REV A
PROPERTY OF	
	
LAYER TOP SILKSCREEN	
DATE:	ALL UNITS ARE IN 0.001"

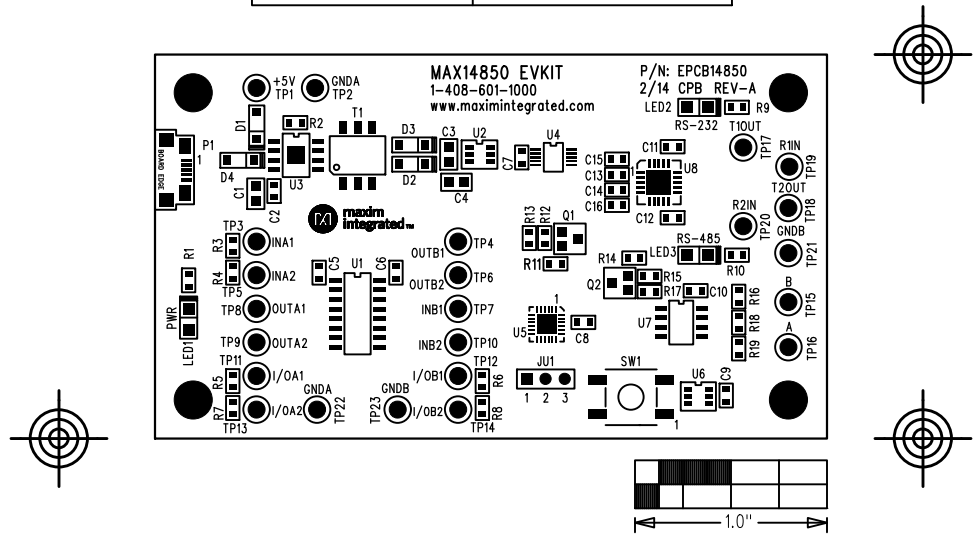

MAX14850 EVKIT	
P/N: EPCB14850	REV A
PROPERTY OF  maxim integrated™	
LAYER LAYER 2 GND	
DATE:	ALL UNITS ARE IN 0.001"

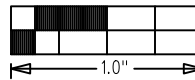
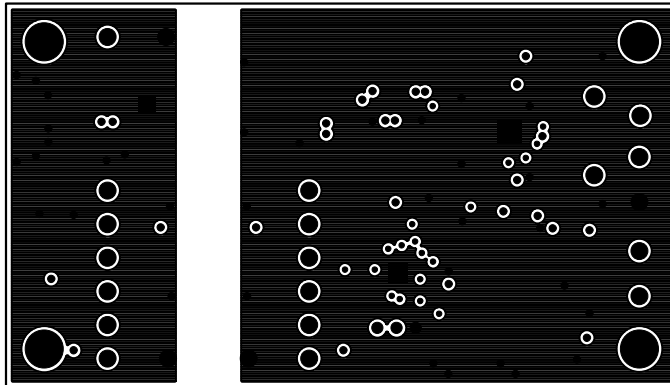

MAX14850 EVKIT	
P/N: EPCB14850	REV A
PROPERTY OF  maxim integrated™	
LAYER LAYER 3 PWR	
DATE:	ALL UNITS ARE IN 0.001"

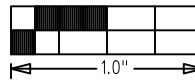
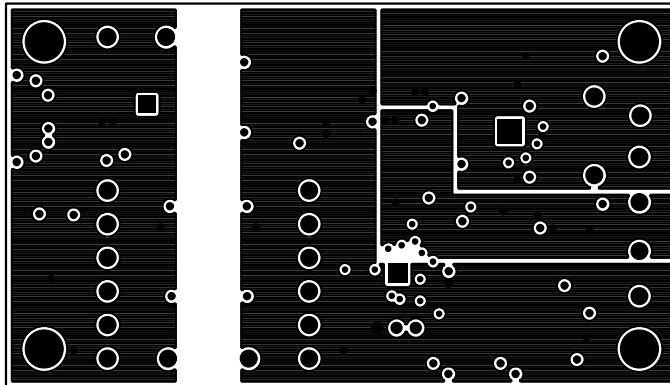

MAX14850 EVKIT	
P/N: EPCB14850	REV A
PROPERTY OF  maxim integrated™	
LAYER COMPONENT SIDE	
DATE:	ALL UNITS ARE IN 0.001"

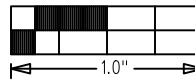
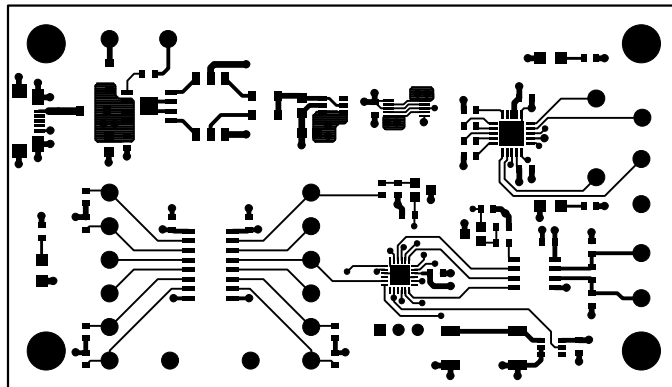

MAX14850 EVKIT	
P/N: EPCB14850	REV A
PROPERTY OF  maxim integrated™	
LAYER SOLDER SIDE	
DATE:	ALL UNITS ARE IN 0.001"

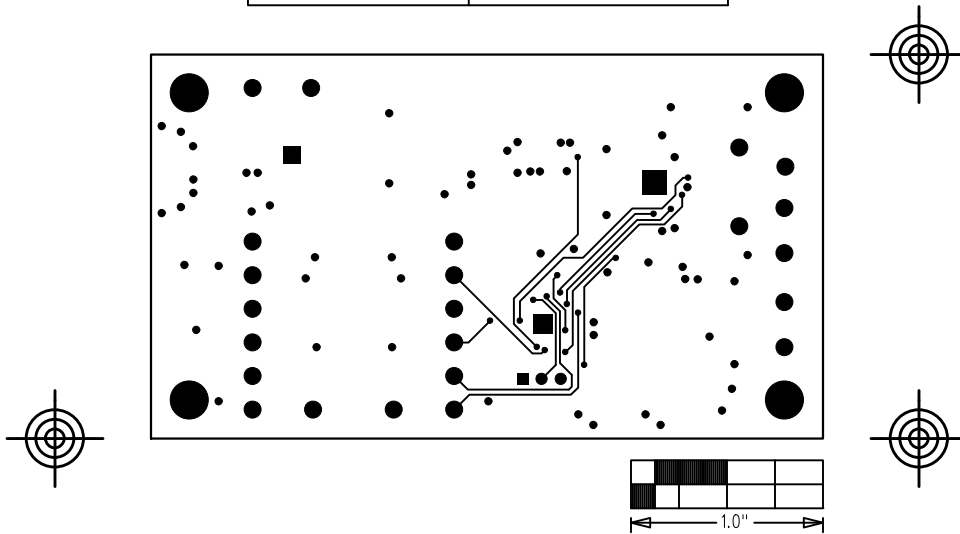

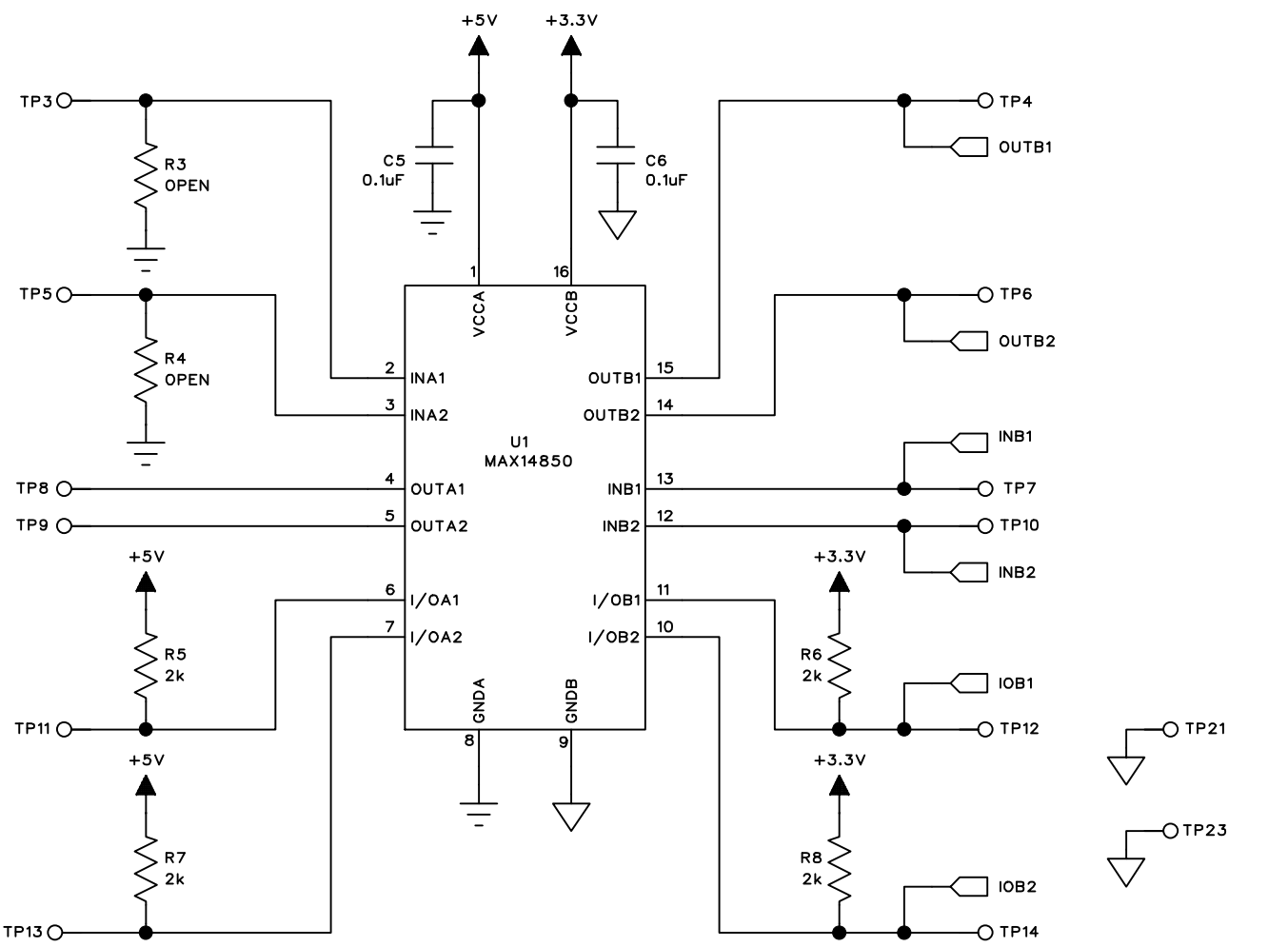
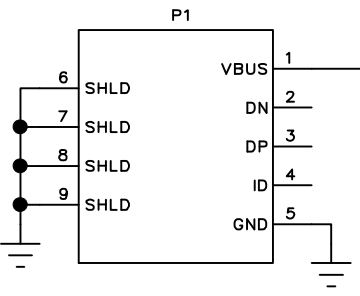
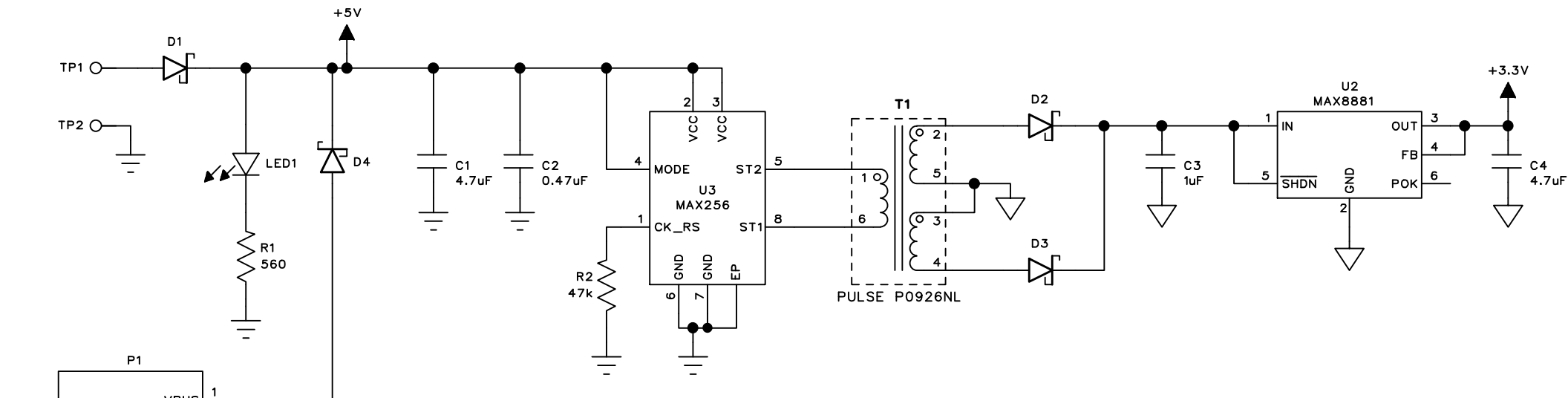

MODE SELECT

