

MAX14895E Evaluation Kit

Evaluates: MAX14895E

General Description

The MAX14895E evaluation kit (EV kit) provides a proven design to evaluate the MAX14895E IC, which integrates level-translating buffers and features RED, GRN, and BLU (RGB) port protection for VGA signals. In addition, horizontal and vertical synchronization (SYNCH0, SYNCV0) inputs feature level-shifting buffers to support low-voltage CMOS or standard TTL-compatible graphics controllers.

The MAX14895E EV kit comes with the MAX14895EETE+ installed.

Features

- ◆ Single 5V DC Supply
- ◆ VGA Input and Output Connectors
- ◆ Proven PCB Layout
- ◆ Fully Assembled and Tested

[Ordering Information](#) appears at end of data sheet.

Component List

DESIGNATION	QTY	DESCRIPTION
C1	1	10 μ F \pm 10%, 16V X5R ceramic capacitor (0805) Murata GRM21BR61C106K
C2–C10, C17	10	0.1 μ F \pm 10%, 16V X5R ceramic capacitors (00603) Murata GRM188R61C104K
C11–C16	0	Not installed, ceramic capacitors (0603)
D1, D2	2	Green LEDs (0603)
D3, D4	2	40V, 500mA Schottky diodes (SOD123) Central Semi CMHSH5-4
GND	1	Black test point
JU1	1	3-pin header
JU2	1	2-pin header

DESIGNATION	QTY	DESCRIPTION
L1, L2, L3	0	Not installed, inductors—short (PC trace) (0603)
P1, P2	2	15-pin VGA, HD sub-D female connectors
R1, R2	2	39 Ω \pm 5% resistors (0603)
R3	1	47k Ω \pm 5% resistor (0603)
R4, R5	2	560 Ω \pm 5% resistors (0603)
U1	1	Enhanced VGA port protector (16 TQFN-EP) Maxim MAX14895EETE+
VCC	1	Red test point
—	2	Shunts
—	1	PCB: MAX14895E EVALUATION KIT

Component Suppliers

SUPPLIER	PHONE	WEBSITE
Central Semiconductor Corp.	631-435-1110	www.centralsemi.com
Murata Electronics North America, Inc.	770-436-1300	www.murata-northamerica.com

Note: Indicate that you are using the MAX14895E when contacting these component suppliers.

MAX14895E Evaluation Kit

Evaluates: MAX14895E

Quick Start

Required Equipment

- MAX14895E EV kit
- PC with VGA connector
- Monitor with VGA connector
- Two VGA cables

Procedure

The EV kit is fully assembled and tested. Follow the steps below to verify board operation:

- 1) Verify that jumpers JU1 and JU2 are in their default positions, as shown in Table 1.
- 2) Connect the first VGA cable from the PC to the VGA connector (P1) on the EV kit.
- 3) Connect the second VGA cable from the monitor to the VGA connector (P2) on the EV kit.
- 4) Enable the monitor.
- 5) Enable the PC.
- 6) Move the shunt on jumper JU1 to the 1-2 position.
- 7) Verify that video is present on the monitor.

Detailed Description of Hardware

The MAX14895E EV kit provides a proven design to evaluate the MAX14895E IC, which integrates level-translating buffers and features RGB port protection for VGA signals. In addition, SYNCH0 and SYNCV0 inputs feature level-shifting buffers to support low-voltage CMOS or standard TTL-compatible graphics controllers.

Enabling (EN and \overline{EN})

The device has dual complementary EN and \overline{EN} enable inputs and can accept either an active-low or active-high enable signal.

The device is in manual operation mode when the shunt on jumper JU2 is not installed. In this configuration, jumper JU1 determines whether the device is enabled.

The device is in automatic operation when jumpers JU1 and JU2 are in their default configuration. In this configuration, connect a monitor to the VGA connector (P2), which automatically enables the device.

Input Supply (Vcc)

Power is applied to the device using the 5V supply from the VGA. Optionally, a 4.75V to 5.25V single supply providing up to 100mA can be applied across the VCC and GND test points. LED D2 indicates that the voltage is present on the EV kit and LED D1 indicates that the V_S output voltage is present from the device.

Table 1. Jumper Descriptions (JU1, JU2)

JUMPER	SHUNT POSITION	DESCRIPTION
JU1	1-2	Enables the device for normal operation.
	2-3*	Disables the device if a shunt is not installed on jumper JU2. If the JU2 shunt is installed, the device is in normal operation.
JU2	Not installed	Disables the device if a shunt is installed in the 2-3 position on jumper JU1.
	1-2*	Enables the device for automatic operation.

*Default position.

MAX14895E Evaluation Kit

Evaluates: MAX14895E

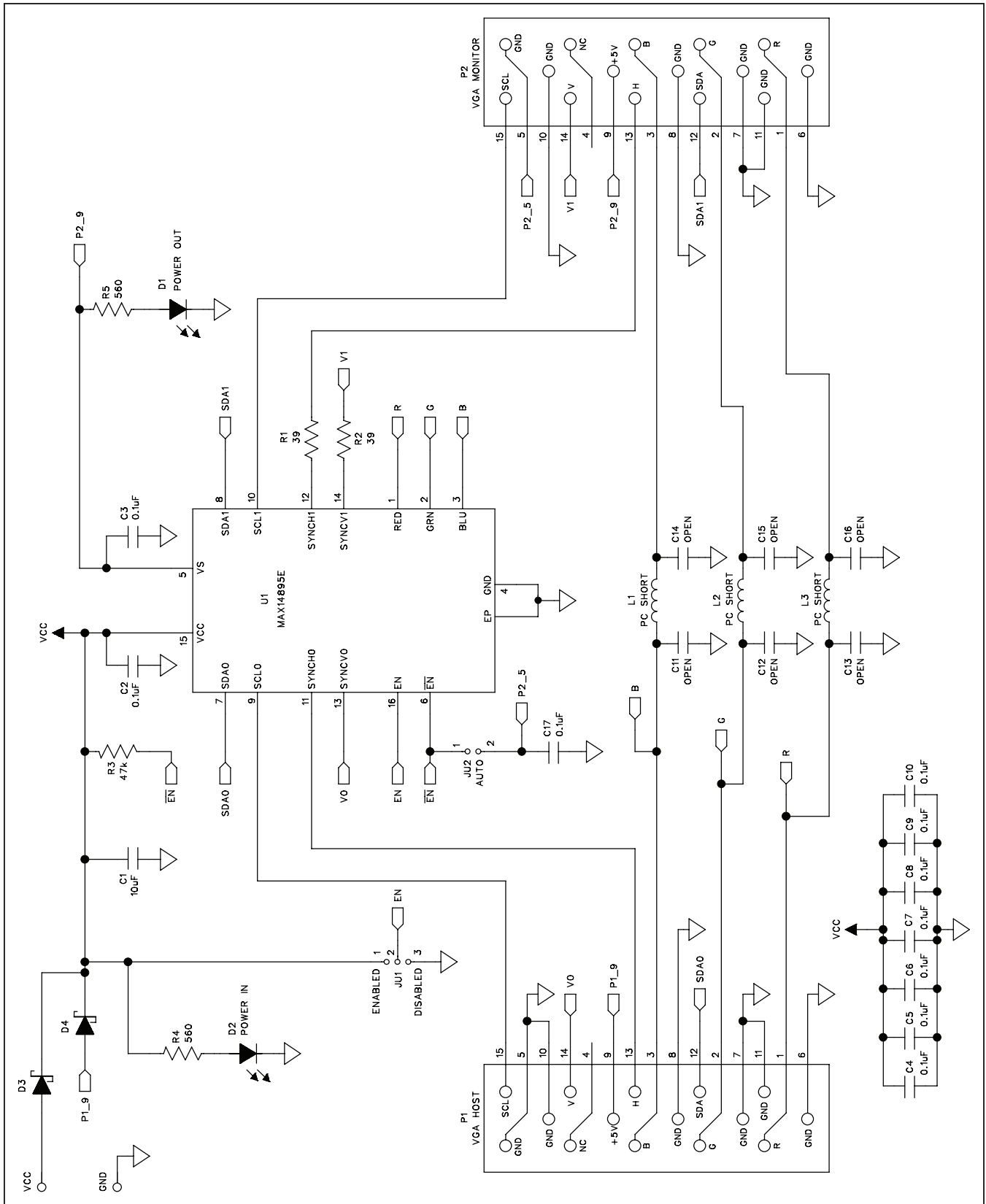

Figure 1. MAX14895E EV Kit Schematic

MAX14895E Evaluation Kit

Evaluates: MAX14895E

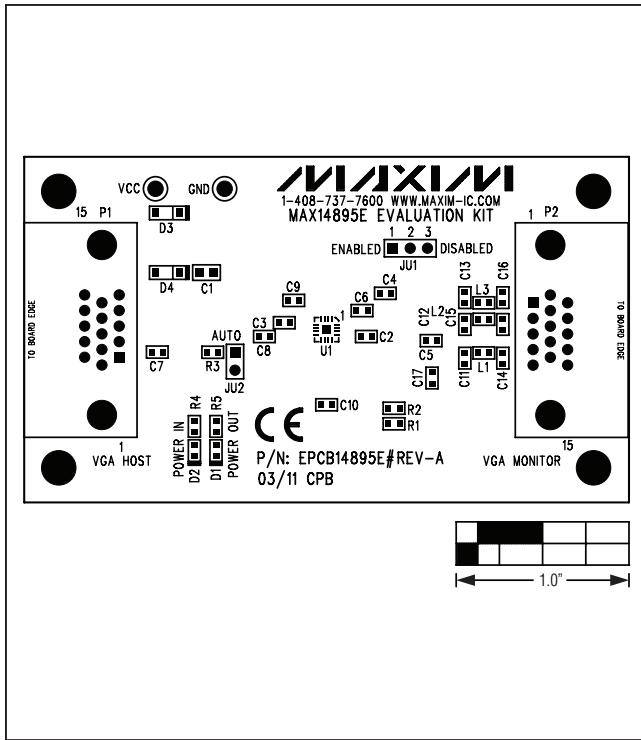

Figure 2. MAX14895E EV Kit Component Placement Guide—Component Side

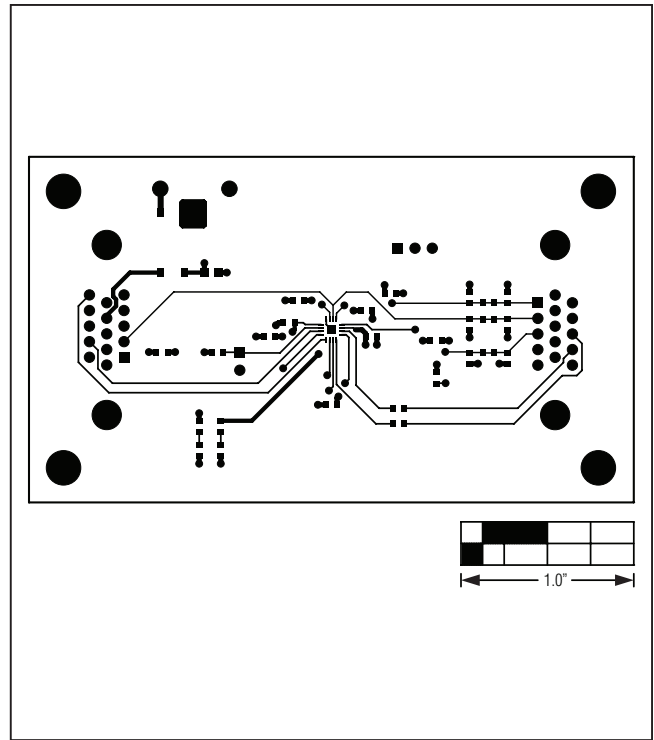

Figure 3. MAX14895E EV Kit PCB Layout—Component Side

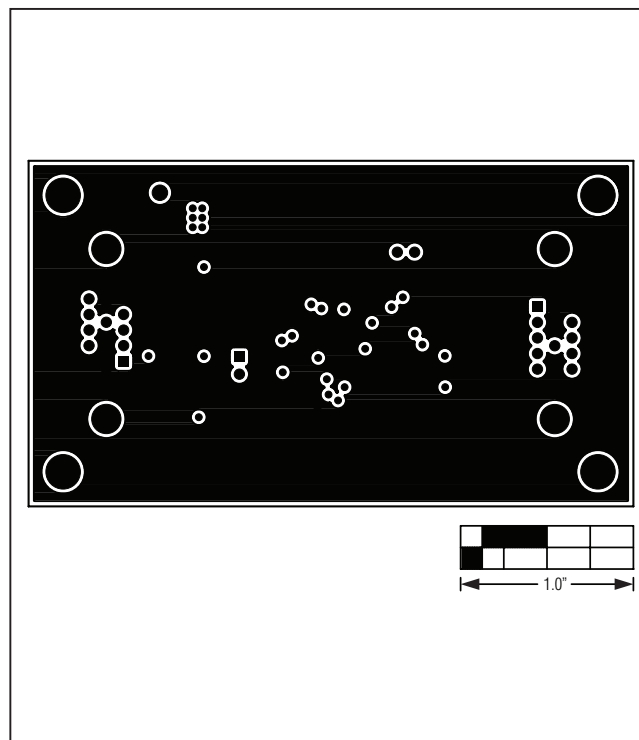

Figure 4. MAX14895E EV Kit PCB Layout—Inner Layer 2

MAX14895E Evaluation Kit

Evaluates: MAX14895E

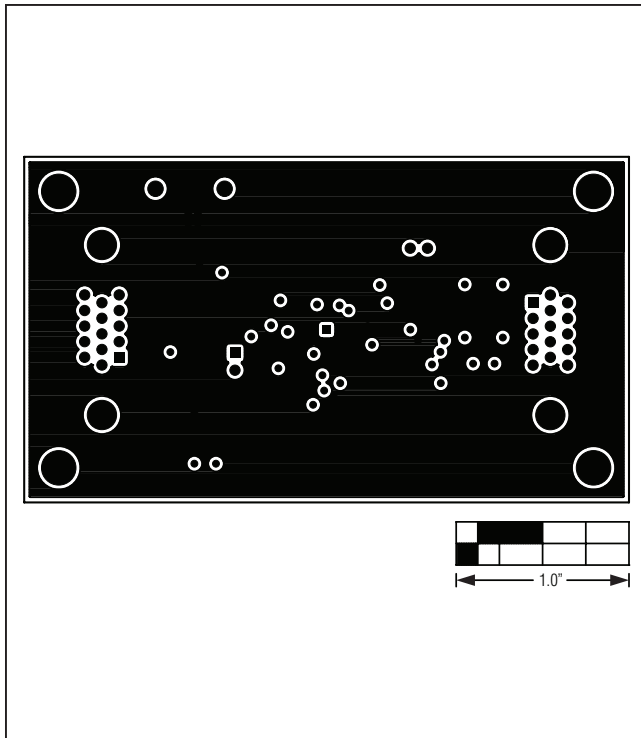

Figure 5. MAX14895E EV Kit PCB Layout—Inner Layer 3

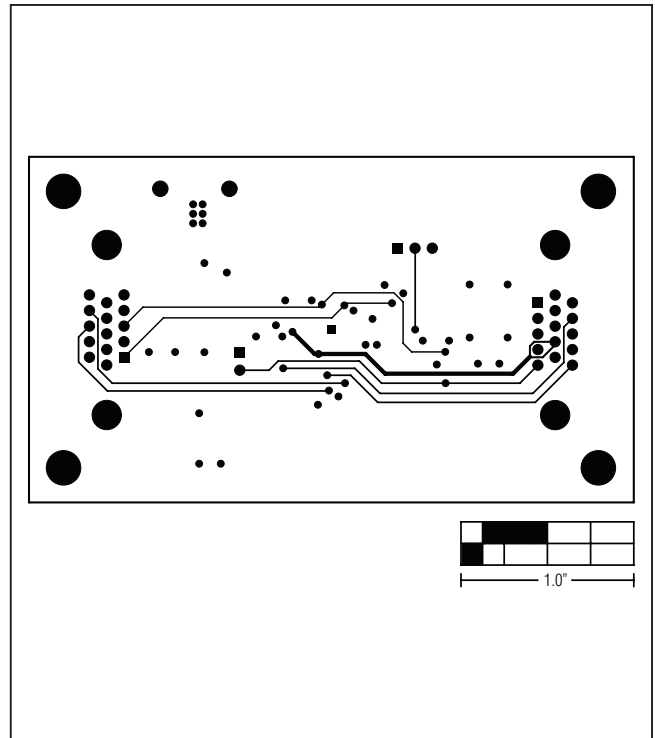

Figure 6. MAX14895E EV Kit PCB Layout—Solder Side

MAX14895E Evaluation Kit

Evaluates: MAX14895E

Ordering Information

PART	TYPE
MAX14895EEVKIT#	EV Kit

#Denotes RoHS compliant.

MAX14895E Evaluation Kit

Evaluates: MAX14895E

Revision History

REVISION NUMBER	REVISION DATE	DESCRIPTION	PAGES CHANGED
0	4/11	Initial release	—

Maxim cannot assume responsibility for use of any circuitry other than circuitry entirely embodied in a Maxim product. No circuit patent licenses are implied. Maxim reserves the right to change the circuitry and specifications without notice at any time.

Maxim Integrated Products, 120 San Gabriel Drive, Sunnyvale, CA 94086 408-737-7600 _____ 7