

MAX17058/MAX17059 Evaluation Kits

Evaluate: MAX17058/MAX17059

General Description

The MAX17058 and MAX17059 evaluation kits (EV kits) consist of the MAX17058 and MAX17059 evaluation kit (EV kit) and the Maxim DS91230+ command module. Windows XP®, Windows Vista®, and Windows® 7-compatible operating systems software is also available for use with the EV kits and can be downloaded from Maxim's website at www.maxim-ic.com/evkitsoftware.

The MAX17058 and MAX17059 EV kits are fully assembled and tested surface-mount PCBs that evaluate the MAX17058 and MAX17059 host- or battery-side fuel gauge for single/double-cell lithium-ion (Li+) batteries in handheld and portable equipment. The EV kits can be powered from a single battery (MAX17058) and can be configured to evaluate a single lithium cell (MAX17058) or two lithium cells in series (MAX17059).

Features

- ◆ **Battery Input Voltage Range**
 - ✧ **MAX17058: +2.5V to +4.5V**
 - ✧ **MAX17059: +2.5V to +12V**
- ◆ **Powered from a Single Battery (MAX17058)**
- ◆ **Evaluates Single-Cell (MAX17058) or 2-Cell (MAX17059) Batteries**
- ◆ **Precision ±7.5mV Voltage Measurement per Cell**
- ◆ **Current Sense Not Required**
- ◆ **On-Board LDO for 2-Cell Evaluation (MAX17059)**
- ◆ **Windows XP-, Windows Vista-, and Windows 7-Compatible Operating Systems Software**
- ◆ **Proven PCB Layout**
- ◆ **Fully Assembled and Tested**

[Ordering Information](#) appears at end of data sheet.

Component List

| DESIGNATION | QTY | DESCRIPTION |
|-------------|-----|---|
| C1, C2 | 2 | 1µF ±10%, 16V X7R ceramic capacitors (0603) Murata GRM188R71C105K TDK C1608X7R1C105K |
| C3 | 1 | 0.1µF ±10%, 16V X7R ceramic capacitor (0402) Murata GRM155R71C104K TDK C1005X7R1C104K |
| C4 | 0 | Not installed, ceramic capacitor (0603) |
| D1, D2, D3 | 3 | 5.6V zener diodes (SOD323) ON Semi MM3Z5V6ST1G |
| J1 | 1 | RJ11 6-pin/6-center right-angle through-hole jack |
| J2 | 1 | 1 x 6-pin straight-row header |
| JU1 | 1 | 3-pin header, 0.1in centers |
| JU2 | 1 | 2-pin header, 0.1in centers |

| DESIGNATION | QTY | DESCRIPTION |
|-------------|-----|--|
| R1, R4, R5 | 3 | 150Ω ±5% resistors (0603) |
| R3 | 0 | Not installed, resistor (0603) (PC short) |
| R6 | 1 | 10kΩ ±5% resistor (0603) |
| R7 | 1 | 1MΩ ±5% resistor (0603) |
| U1 | 1 | See the <i>EV Kit-Specific Component List</i> |
| U2 | 1 | 3.3V LDO (5 SOT23) Maxim MAX1726EUK33-T |
| — | 1 | DS91230 PicBrick board (USB to RJ11) Maxim DS91230+ |
| — | 1 | RJ12 6-pos/6-pos reverse modular cord, 7ft |
| — | 2 | Shunts |
| — | 1 | PCB: MAX17058/MAX17059 EVALUATION KIT |

Windows, Windows XP, and Windows Vista are registered trademarks of Microsoft Corp.

MAX17058/MAX17059 Evaluation Kits

Evaluate: MAX17058/MAX17059

EV Kit-Specific Component List

| PART | DESIGNATION | DESCRIPTION |
|----------------|-------------|---|
| MAX17058EVKIT# | U1 | 1-cell Li+ ModelGauge™ IC (8 TDFN-EP*) Maxim MAX17058G+T10 |
| MAX17059EVKIT# | | 2-cell Li+ ModelGauge IC (8 TDFN-EP*) Maxim MAX17059G+T10 |

*EP = Exposed pad.

Component Suppliers

| SUPPLIER | PHONE | WEBSITE |
|--|--------------|-----------------------------|
| Murata Electronics North America, Inc. | 770-436-1300 | www.murata-northamerica.com |
| ON Semiconductor | 602-244-6600 | www.onsemi.com |
| TDK Corp. | 847-803-6100 | www.component.tdk.com |

Note: Indicate that you are using the MAX17058/MAX17059 when contacting these component suppliers.

MAX17058 EV Kit Files

| FILE | DESCRIPTION |
|---------------|--|
| SETUP.EXE | Installs the EV kit files on your computer |
| MAX17058k.EXE | Application program |
| README.HTML | Help file |

MAX17059 EV Kit Files

| FILE | DESCRIPTION |
|---------------|--|
| SETUP.EXE | Installs the EV kit files on your computer |
| MAX17059k.EXE | Application program |
| README.HTML | Help file |

Quick Start

Required Equipment

- MAX17058 or MAX17059 EV kit
- +2.5V to +4.5V DC power supply or single-cell battery
- DS91230+ PicBrick
- RJ12 6-pos/6-pos reverse modular cord
- PC with Windows XP, Windows Vista, or Windows 7 OS
- USB port

Note: In the following sections, software-related items are identified by bolding. Text in **bold** refers to items directly from the EV kit software. Text in **bold and underlined** refers to items from the Windows operating system.

Procedure

The EV kits are fully assembled and tested. Follow the steps below to verify board operation. **Caution: Do not turn on the power supply until all connections are completed.**

- 1) Connect the DS91230+ board to a spare USB port on the PC.
- 2) Connect the RJ12 cord between J2 on the DS91230+ board and J1 on the EV kit.

- 3) Verify that shunts are installed according to the defaults listed in [Table 1](#).
- 4) Connect the positive terminal of the power supply or battery to the BAT+ PCB pad on the EV kit. Connect the negative terminal of the power supply to the BAT- PCB pad on the EV kit.
- 5) Download the latest version of the EV kit software at www.maxim-ic.com/evkitsoftware, MAX17058Rxx.ZIP or MAX17059Rxx.ZIP. Save the EV kit software to a temporary folder and uncompress the ZIP file.
- 6) Install the EV kit software on your computer by running the SETUP.EXE program inside the temporary folder. The program files are copied and icons are created in the Windows **Start | Programs** menu. The software requires the .NET Framework 4. If you are connected to the Internet, Windows automatically locates the correct files and walks you through the process. You can also download the **Microsoft .NET Framework 4 Client Profile (Standalone Installer)** and run that on your PC.
- 7) Start the EV kit software by opening its icon in the **Start | Programs** menu.
- 8) Load the default or custom battery model.

ModelGauge is a trademark of Maxim Integrated Products, Inc.

MAX17058/MAX17059 Evaluation Kits

Evaluate: MAX17058/MAX17059

Detailed Description of Hardware

The MAX17058/MAX17059 EV kits are fully assembled and tested surface-mount PCBs that evaluate the MAX17058 and MAX17059 host- or battery-side fuel gauge for single/double-cell Li+ batteries in handheld and portable equipment. The EV kits can be powered from a single supply or battery with an input range of +2.5V to +4.5V. The EV kit can be configured to evaluate a single lithium cell (MAX17058) or two lithium cells in series (MAX17059). Optional LDO U2 is provided to power VIN when using a higher voltage 2-cell Li+ battery to evaluate the MAX17059.

Default Jumper Settings

The MAX17058 EV kit is set by default to evaluate single-cell Li+ batteries, while the MAX17059 EV kit is set by default to evaluate 2-cell Li+ batteries. LDO U2 is provided so that only a single supply is needed to power the EV kit in the case where a 2-cell battery is used.

When evaluating the MAX17058, set jumper JU1 to pins 1-2 and remove any shunt installed on JU2 to bypass the LDO. When evaluating the MAX17059, set jumper JU1 to pins 2-3 and install a shunt on JU2 to power VIN from the LDO. See [Table 2](#) and [Table 3](#) for jumper JU1 and JU2 settings. **Note:** When using a separate supply for VIN or evaluating the MAX17058, JU2 should be uninstalled to prevent additional current drawn from the battery.

Table 1. Default Jumper Positions

| JUMPER | DEFAULT SHUNT POSITION | |
|--------|------------------------|-----------|
| | MAX17058 | MAX17059 |
| JU1 | 1-2 | 2-3 |
| JU2 | Open | Installed |

Table 2. Power-Supply Input (JU1)

| SHUNT POSITION | VDD PIN | EV KIT CONFIGURATION |
|----------------|---|----------------------|
| 1-2* | Powered from a battery applied between BAT+ and BAT- PCB pads | MAX17058 |
| 2-3 | Powered from +5V output of LDO U2 | MAX17059 |

*MAX17058 default position.

Table 3. LDO U2 Input Settings (JU2)

| SHUNT POSITION | U2 INPUT | U2 OUTPUT | EV KIT CONFIGURATION |
|----------------|---------------------------|-----------|----------------------|
| Installed | Connected to BAT+ PCB pad | Enabled | MAX17058 |
| Not Installed* | Unconnected | Disabled | MAX17059 |

*MAX17058 default position.

MAX17058/MAX17059 Evaluation Kits

Evaluate: MAX17058/MAX17059

Detailed Description of Software

Splash Screen

The splash screen (Figure 1) allows you to choose one of three distinct modes:

- Custom model with physical MAX17058/MAX17059. Custom models for MAX17040/1/3/4 can be used in this software provided you change the line: Device = MAX1704x to Device = MAX17058.
- Default model with physical MAX17058.

Warning: Using the default model normally results in poor fuel-gauge performance. For good fuel-gauge performance, it is recommended to always use a model that is matched to the battery according to battery characterization.

- Demo mode with a MAX17058 log file.

Note that the MAX17059 EV kit software is also available for download at Maxim's website at www.maxim-ic.com/evkitsoftware.

Main Window

You can resize the left-right split in the window (Figure 2). Most major functionality is available from the menu, but some of the following items should be observed early.

Currently Loaded Custom Battery Model

This group displays any custom model that has been loaded onto the part by the software. If the device resets, this model is automatically reloaded. If you are using the default model, nothing is displayed here. Any changes to the configuration file are not reloaded automatically.

Record Registers to Log File

This group displays the file path to which the software is recording the registers. If this box is blank, no file is being saved.

RCOMP Configuration

You can enter a byte here and press the **Write RCOMP** button to write it to the device. This is not the same as writing the value into the memory map, because RCOMP is part of a larger 2-byte register.

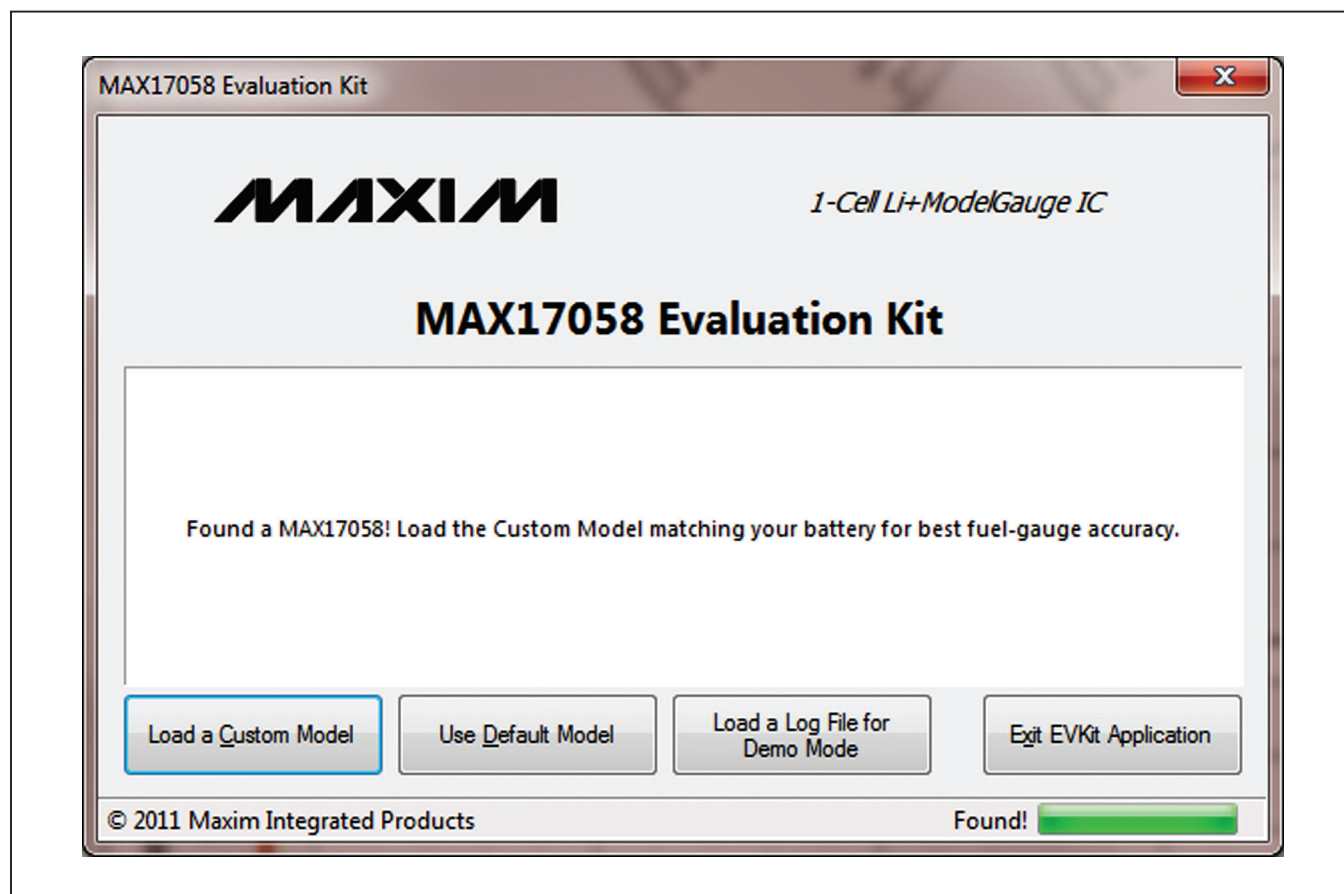

Figure 1. MAX17058 EV Kit Software (Splash Screen)

MAX17058/MAX17059 Evaluation Kits

Evaluate: MAX17058/MAX17059

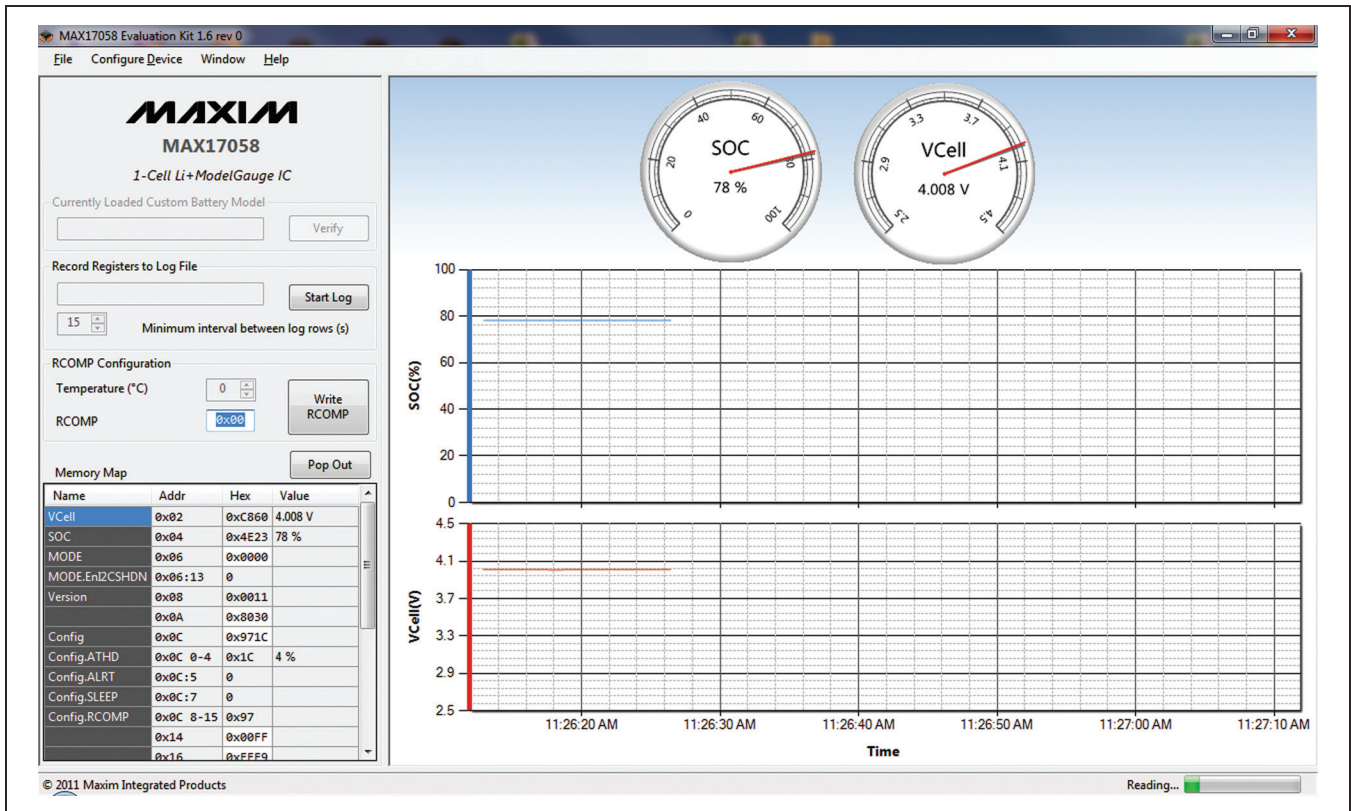

Figure 2. MAX17058 EV Kit Software (Main Window)

If you have a custom model, you can also change the temperature, which adjusts the MAX17058 for proper temperature performance. Changing this value immediately calculates a new value of RCOMP and displays it in the box. This value is not written to the device until you press the **Write RCOMP** button. A change to RCOMP is not reflected in the temperature.

Memory Map

Notation used for **Name** and **Addr** should be familiar to C programmers with one small change. The memory map lists:

- Name: A dot indicates that a single address has multiple meanings. This is similar to how the C firmware might access the bits.
- Addr: A colon indicates the 0-indexed location, not the size of the bit field. A dash indicates a range of values (e.g., 0x0C:0-4 is a 5-bit value, offset 0 bits at address 0x0C).
- Hex: The raw value as read directly from the device
- Value: A conversion of the raw hex value, usually with units. Alert bit flags are blank when inactive, or show text when they are alerting.

- Description: Reminders of the functionality. For full details, refer to the MAX17058/MAX17059 IC data sheet.

You can write values to the device directly through the memory map. To write a raw hex value, select the cell in the **Hex** column, overwrite the value, and press the Enter or Tab key. You will be prompted to write to the device. Normal communication pauses, and you will see a corresponding blank spot in the graph.

For registers with a conversion factor (e.g., **Hibernate Threshold** or **VAlertMax**), you can also modify the Value column. The software converts the value back to the raw hex, and prompts to verify that you are writing what you expect.

Remember that not all registers are writable.

Plot

The plot can be configured using the **Preferences** window. The plot is interactive. You can zoom into the **Time** axis by left-clicking and dragging anywhere in the plot area. You will see the region highlighted as you drag. You can zoom out either by pressing the small button in the bottom left, or by right-clicking in the plot area.

Plotted information not in a log file cannot be recovered once the application closes.

MAX17058/MAX17059 Evaluation Kits

Evaluate: MAX17058/MAX17059

The top and bottom plots are synchronized in time, so zooming one zooms the other. The y-axes are fixed scale, and you cannot modify which registers are plotted, or where.

Stand-Alone Windows **Preferences**

This area contains options for how frequently one wishes to read the device and how to plot points. If you are trying to observe transient events, you need to increase the read speed, as well as how frequently the points are actually plotted.

The plots can use a lot of system memory if you read frequently for a long time, so be aware of these settings. After the maximum number of points is reached, points are trimmed from the beginning. The discarded points cannot be recovered on the plot.

I²C Traffic Log Window

Here you can see a log of traffic which you initiate, as well as any time the device is programmed. It describes each step in detail, including the particular values read or written. This can help remove uncertainty about how to communicate with the device. This log does not show the standard reading events.

Memory Map Pop-Up Window

This displays the same information as the memory map on the main application, except you cannot modify values in this map. This is the easiest place to read descriptions of registers.

MAX17058/MAX17059 Evaluation Kits

Evaluate: MAX17058/MAX17059

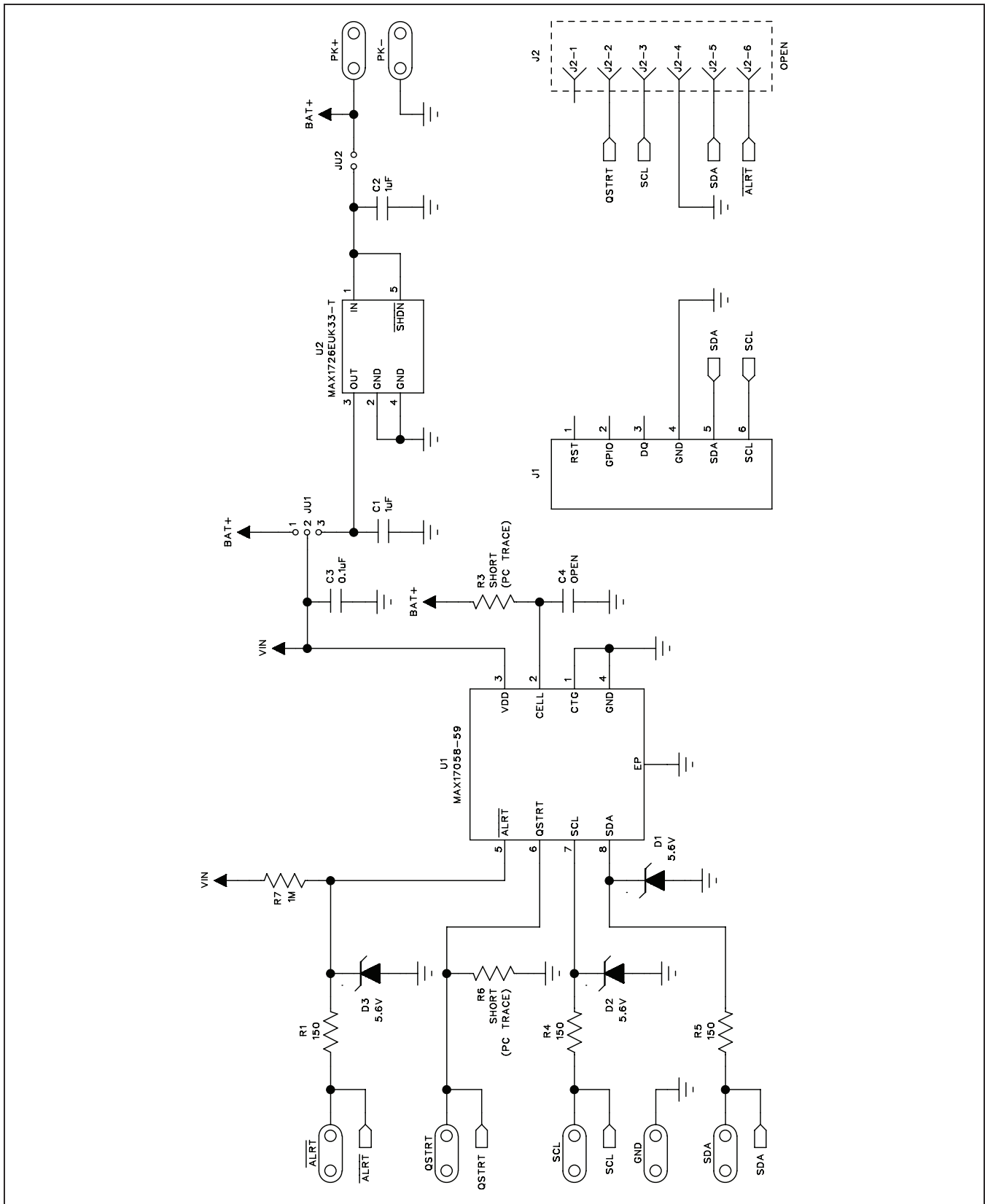

Figure 3. MAX17058/MAX17059 EV Kit Schematic

MAX17058/MAX17059 Evaluation Kits

Evaluate: MAX17058/MAX17059

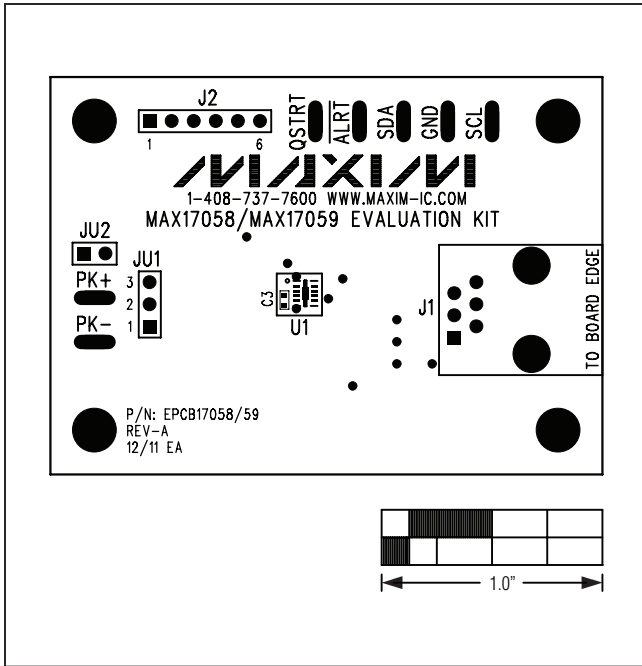

Figure 4. MAX17058/MAX17059 EV Kit Component Placement Guide—Component Side

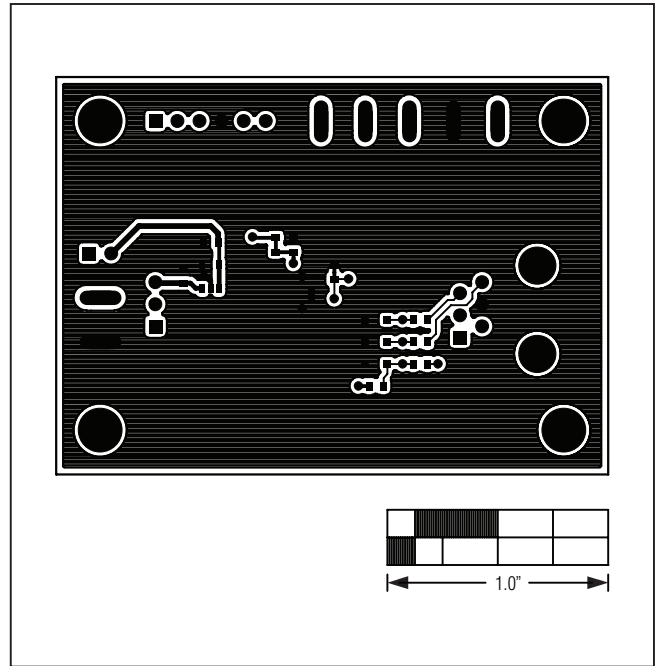

Figure 6. MAX17058/MAX17059 EV Kit PCB Layout—Solder Side

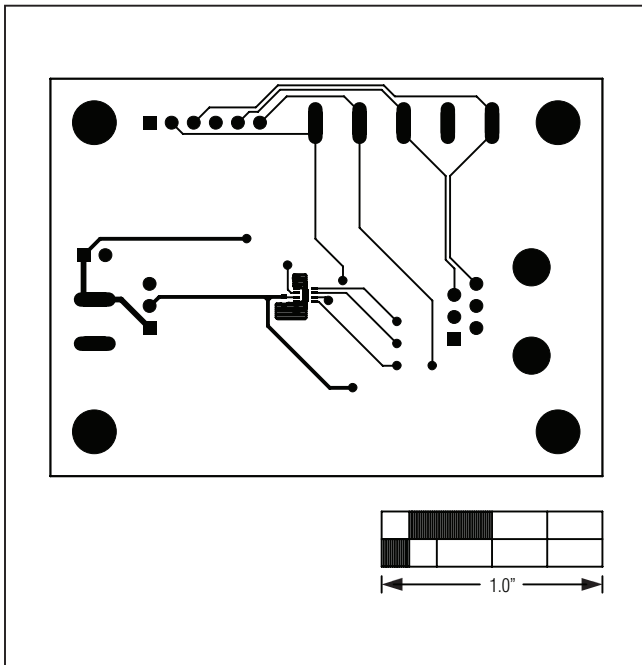

Figure 5. MAX17058/MAX17059 EV Kit PCB Layout—Component Side

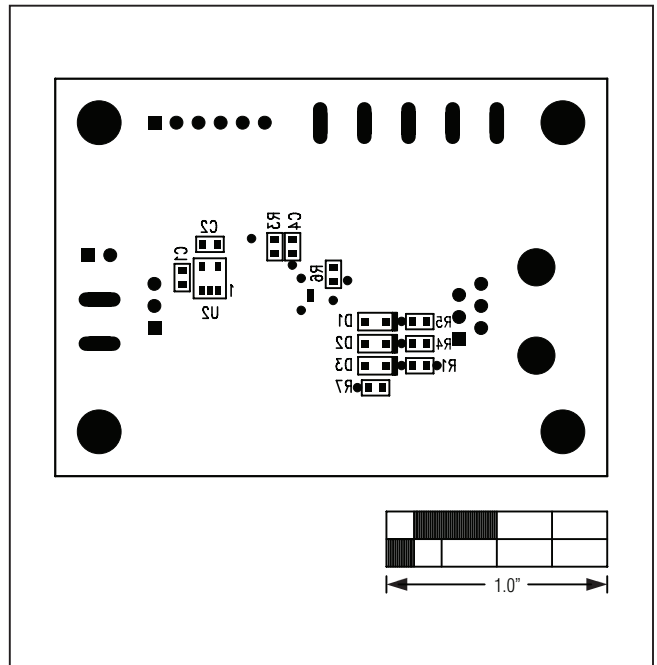

Figure 7. MAX17058/MAX17059 EV Kit Component Placement Guide—Solder Side

MAX17058/MAX17059 Evaluation Kits

Evaluate: MAX17058/MAX17059

Ordering Information

| PART | TYPE |
|----------------|--------|
| MAX17058EVKIT# | EV Kit |
| MAX17059EVKIT# | EV Kit |

#Denotes RoHS compliant.

MAX17058/MAX17059 Evaluation Kits

Evaluate: MAX17058/MAX17059

Revision History

| REVISION NUMBER | REVISION DATE | DESCRIPTION | PAGES CHANGED |
|-----------------|---------------|--|---------------|
| 0 | 1/12 | Initial release | — |
| 1 | 2/12 | Updated U1 description in the EV Kit-Specific Component List and Figures 1 and 2 | 2, 4, 5 |

Maxim cannot assume responsibility for use of any circuitry other than circuitry entirely embodied in a Maxim product. No circuit patent licenses are implied. Maxim reserves the right to change the circuitry and specifications without notice at any time.

Maxim Integrated Products, 120 San Gabriel Drive, Sunnyvale, CA 94086 408-737-7600 _____ **10**