

MAX17223 Evaluation Kit

Evaluates: MAX17220–MAX17225

General Description

The MAX17223 evaluation kit (EV kit) evaluates the MAX17220–MAX17225 IC family of ultra-low quiescent current step-up DC-DC converters. The MAX17223 EV kit features two independent circuits to evaluate two different IC packages of the MAX17220–MAX17225 family. Both circuits on the EV kit operate over an input range of 400mV to 5.5V, depending on load, with 0.88V typical startup with 3k Ω load. Each circuit provides resistor-configurable output voltages from 1.8V to 5V in 100mV/step.

The EV kit comes with the MAX17223ELT+ and MAX17223ENT+ installed.

Features

- Two Independent Circuits on One Board
 - Evaluates the MAX17220–MAX17225 IC Family in a 6-pin μ DFN
 - Evaluates the MAX17220–MAX17225 IC Family in a 6-pin Wafer-Level Package (WLP)
- 400mV to 5.5V Input Range
- 1.8V to 5V Configurable Output Voltage in 100mV/step
- Up to 100mA/225mA/425mA Output Current
- Proven 2-Layer 1oz Copper PCB Layout
- Demonstrates Compact Solution Size
- Fully Assemble and Tested

MAX17223 EV Kit Files

FILE	DESCRIPTION
MAX17223 EV BOM	EV Kit Bill of Material
MAX17223 EV PCB Layout Diagrams	EV Kit Layout
MAX17223 EV Schematic	EV Kit Schematic
MAX17223 EV Minimal Component Schematic	Minimal Component Circuit

Ordering Information appears at end of data sheet.

Quick Start

Required Equipment

- MAX17223 EV kit
- 1.8V to 5V, 3A DC power supply
- Electronic load capable of 225mA
- Digital voltmeter (DVM)

Procedure

The EV kit is fully assembled and tested. Follow the steps below to verify board operation.

Caution: Do not turn on power supply until all connections are completed.

Testing the 3V Output Circuit

- 1) Verify that jumper JU101 is in its default position, as shown in [Table 2](#).
- 2) Connect the power supply between the IN and nearest GND terminal posts.
- 3) Connect the electronic load between the 3V output and nearest GND terminal posts.
- 4) Connect the DVM between the 3V output and nearest GND terminal posts.
- 5) Set the input power supply to 1.8V and turn on the power supply.
- 6) Set the electronic load to 225mA and enable the electronic load.
- 7) Verify that the voltage at the 3V terminal post is approximately 3V.

Testing the 5V Output Circuit

- 1) Verify that jumper JU1 is in its default position, as shown in [Table 1](#).
- 2) Connect the power supply between the IN1 and nearest GND1 terminal posts.
- 3) Connect the electronic load between the 5V output and nearest GND1 terminal posts.
- 4) Connect the DVM between the 5V output and a nearest GND1 terminal posts.
- 5) Set the input power supply to 3V, and turn on the power supply.
- 6) Set the electronic load to 225mA, and enable the electronic load.
- 7) Verify that the voltage at the 5V terminal post is approximately 5V.

Detailed Description of Hardware

The MAX17223 EV kit evaluates the MAX17220–MAX17225 IC family of ultra-low quiescent current step-up DC-DC converters. The MAX17223 EV kit features two independent circuits to evaluate two different IC packages of the MAX17220–MAX17225 family. Both circuits on the EV kit operate over an input range of 400mV to 5.5V. Each circuit provides resistor-configurable output voltages from 1.8V to 5V in 100mV/step.

The MAX17223 EV Kit comes with a MAX17223ELT+ (µDFN) and a MAX17223ENT+ (WLP) installed. The MAX17223ELT+ circuit is configured for a 3V output, and can deliver 225mA with 1.8V input. The MAX17223ENT+ circuit is configured for a 5V output, and can deliver 225mA with 3V input.

EN for the WLP Circuit

The WLP circuit on the EV kit provides a jumper (JU1) to enable or disable the MAX17223ENT+. Refer to [Table 1](#) for JU1 jumper settings.

EN for the µDFN Circuit

The µDFN circuit on the EV kit provides a jumper (JU101) to enable/disable the MAX17223ELT+. Refer to [Table 2](#) for JU101 jumper settings.

Battery Holders

The MAX17223 EV kit provides battery holders for each of the two circuits. The battery holder V1 can accommodate a CR1632 Lithium Coin cell to power the WLP circuit, while the V101 can hold an Energizer 364/363 silver oxide cell to power the µDFN circuit.

Table 1. EN on MAX17223ENT+ (JU1)

JU1 SHUNT POSITION	DESCRIPTION
1-2*	Enabled. EN = IN1 (through pullup resistor R2)
2-3	Disabled. EN = GND1
Installed*	Enabled. EN = high (through internal pullup resistor)

*Default position.

Spare Resistors and Inductors

The EV kit provides spare resistors and inductors on the PCB's bottom side. The spare resistors can be used to reconfigure the EV kit to a different output voltage (2V, 2.5V, 3V, or 3.3V). The spare inductors can be used to reconfigure the EV Kit output current ratings.

Table 2. EN on MAX17223ELT+ (JU101)

JU101 SHUNT POSITION	DESCRIPTION
1-2*	Enabled. EN = IN (through pullup resistor R102)
2-3	Disabled. EN = GND
Not Installed	Enabled. EN = high (through internal pullup resistor)

*Default position.

Evaluating other ICs

The MAX17223 EV kit can also evaluate other ICs in the MAX17220–MAX17225 IC family. To evaluate the other ICs, replace U1 and/or U101 with the desired IC/IC package. Refer to the MAX17220–MAX17225 IC data sheet for additional information.

Component Suppliers

SUPPLIER	WEBSITE
Coilcraft	www.coilcraft.com
Murata/TOKO	www.murata.com
TDK	www.tdk.com
Wurth Elektronik	www.we-online.com

Note: Indicate that you are using the MAX17220–MAX17225 when contacting these component suppliers.

Ordering Information

PART	TYPE
MAX17223EVKIT#	EV Kit

#Denotes RoHS

MAX17223 EV Kit Bill of Materials

ITEM	REF_DES	DNI/DNP	QTY	MFG PART #	MANUFACTURER	VALUE	DESCRIPTION
1	3V, 5V, LX, LX1	—	4	131-4353-00	TEKTRONICS	131-4353-00	CONNECTOR; WIREMOUNT; CIRCUIT BOARD TEST POINT MINIATURE PROBE; STRAIGHT; 4PINS;
2	C1, C101	—	2	GRM155R60J106ME44	MURATA	10 μ F	CAPACITOR; SMT (0402); CERAMIC CHIP; 10 μ F; 6.3V; TOL = 20%; TG = -55°C TO +85°C; TC = X5R;
3	C4, C104	—	2	GRM155R61A106ME44	MURATA	10 μ F	CAPACITOR; SMT (0402); CERAMIC CHIP; 10 μ F; 10V; TOL = 20%; TG = -55°C TO +85°C; TC = X5R;
4	GND, GND1, IN, IN1, J1-J4	—	8	1514-2	KEYSTONE	1514-2	TERMINAL; TURRET; PIN DIA = 0.090IN; TOTAL LENGTH = 0.105IN; BOARD HOLE = 0.098IN; BRASS; TIN PLATING;
5	JU1, JU101	—	2	PEC03SAAN	SULLINS	PEC03SAAN	CONNECTOR; MALE; THROUGH HOLE; BREAKAWAY; STRAIGHT; 3PINS
6	L1	—	1	DFE201612E-2R2M	MURATA	2.2 μ H	INDUCTOR; SMT (0806); WIREWOUND CHIP; 2.2 μ H; TOL = \pm 20%; 1.8A
7	L101	—	1	XFL4020-222ME	COILCRAFT	2.2 μ H	INDUCTOR; SMT; METAL COMPOSITE CORE; 2.29H; TOL = \pm 20%; 8A; -40°C TO +125°C
8	R1	—	1	CRCW12060000ZS; ERJ-8GEY0R00	VISHAY DALE; PANASONIC	0	RESISTOR; 1206; 0 Ω ; 0%; JUMPER; 0.25W; THICK FILM
9	R2, R102	—	2	HMC0402JT33M0	STACKPOLE ELECTRONICS INC	33M	RESISTOR; 0402; 33M Ω ; 5%; 400PPM; 0.063W; THICK FILM
10	R3, R4, R103, R104	—	4	ERJ-2GE0R00	PANASONIC	0	RESISTOR; 0402; 0 Ω ; 0%; JUMPER; 0.10W; THICK FILM
11	R101	—	1	RMCF1206FT133K	STACKPOLE ELECTRONICS INC	133K	RESISTOR; 1206; 133K Ω ; 1%; 100PPM; 0.25W; THICK FILM
12	SU1, SU101	—	2	S1100-B; SX1100-B; STC02SYAN	KYCON; KYCON; SULLINS ELECTRONICS CORP.	SX1100-B	TEST POINT; JUMPER; STR; TOTAL LENGTH = 0.24IN; BLACK; INSULATION = PBT; PHOSPHOR BRONZE CONTACT = GOLD PLATED
13	U1	—	1	MAX17223ENT+	MAXIM	MAX17223ENT+	IC; CONV; 0.4V TO 5.5V INPUT; NANOPOWER SYNCHRONOUS BOOST CONVERTER WITH TRUE SHUTDOWN; WLP6
14	U101	—	1	MAX17223ELT+	MAXIM	MAX17223ELT+	IC; CONV; 0.4V TO 5.5V INPUT; NANOPOWER SYNCHRONOUS BOOST CONVERTER WITH TRUE SHUTDOWN; UDFN6
15	V1	—	1	BHX1-1632-SM	MEMORY PROTECTION DEVICES INC.	BHX1-1632-SM	BATTERY HOLDER; SMT; CR1632 SURFACE MOUNT BATTERY RETAINER WITH INSULATOR; CONTACTS: PHOSPHOR BRONZE C5191; NICKEL PLATED 80-150U THICK

MAX17223 EV Kit Bill of Materials (continued)

ITEM	REF_DES	DNI/DNP	QTY	MFG PART #	MANUFACTURER	VALUE	DESCRIPTION
16	V101	—	1	BK-879	MEMORY PROTECTION DEVICES INC.	BK-879	BATTERY HOLDER; SMT; COIN CELL RETAINER FOR 6.8MM DIA. BATTERIES; 0.25MM PHOSPHOR BRONZE; NICKEL PLATED
17	PCB	—	1	MAX17223	MAXIM	PCB	PCB:MAX17223
18	MTH1-MTH4	DNI	4	9032	KEYSTONE	9032	MACHINE FABRICATED; ROUND-THRU HOLE SPACER; NO THREAD; M3.5; 5/8IN; NYLON
19	C2, C3, C102, C103	DNP	0	N/A	N/A	OPEN	PACKAGE OUTLINE 0402 NON-POLAR CAPACITOR
20	C5, C105	DNP	0	N/A	N/A	OPEN	PACKAGE OUTLINE 0603 NON-POLAR CAPACITOR
21	TP1-TP8	DNP	0	5002	KEYSTONE	N/A	TEST POINT; PIN DIA = 0.1IN; TOTAL LENGTH = 0.3IN; BOARD HOLE = 0.04IN; WHITE; PHOSPHOR BRONZE WIRE SILVER;
22	L1C	Spare	1	MLP1005M1R0DT0S1	TDK	1 μ H	INDUCTOR; SMT (0402); FERRITE CHIP; 1 μ H; TOL = \pm 20%; 0.5A
23	L1F	Spare	1	DFE160808S-1R0M=P2	MURATA	1 μ H	INDUCTOR; SMT (0603); MAGNETICALLY SHIELDED; 1 μ H; TOL = \pm 20%; 1.9A
24	L1V	Spare	1	DFE18SBN2R2MELL	MURATA	2.2 μ H	EVKIT PART - INDUCTOR; SMT (0603); SHIELDED; 2.2 μ H; 20%; 1.2A
25	L1W	Spare	1	DFE201612E-1R0M	MURATA	1 μ H	INDUCTOR; SMT (0806); WIREWOUND CHIP; 1 μ H; TOL = \pm 20%; 2.9A
26	L1X	Spare	1	74479299222	WURTH ELECTRONICS INC	2.2 μ H	INDUCTOR; SMT (1210); MOLDED CHIP; 2.2 μ H; TOL = \pm 20%; 2.1A
27	L1Y	Spare	1	74438357022	WURTH ELECTRONICS INC	2.2 μ H	EVKIT PART-INDUCTOR; SMT; SHIELDED; 2.2 μ H; TOL = \pm 20%; 5.2A;
28	R101A	Spare	1	RMCF1206FT768K; ERJ-8ENF7683	STACKPOLE ELECTRONICS INC; PANASONIC	768K	RESISTOR; 1206; 768K Ω ; 1%; 100PPM; 0.25W; THICK FILM
29	R101B	Spare	1	RMCF1206FT324K	STACKPOLE ELECTRONICS INC	324K	RESISTOR; 1206; 324K Ω ; 1%; 100PPM; 0.25W; THICK FILM
30	R101C	Spare	1	RMCF1206FT133K	STACKPOLE ELECTRONICS INC	133K	RESISTOR; 1206; 133K Ω ; 1%; 100PPM; 0.25W; THICK FILM
31	R101D	Spare	1	RMCF1206FT80K6; ERJ-8ENF8062	STACKPOLE ELECTRONICS INC; PANASONIC	80.6K	RESISTOR; 1206; 80.6K Ω ; 1%; 100PPM; 0.25W; THICK FILM
TOTAL			49				

MAX17223 EV Kit Schematic

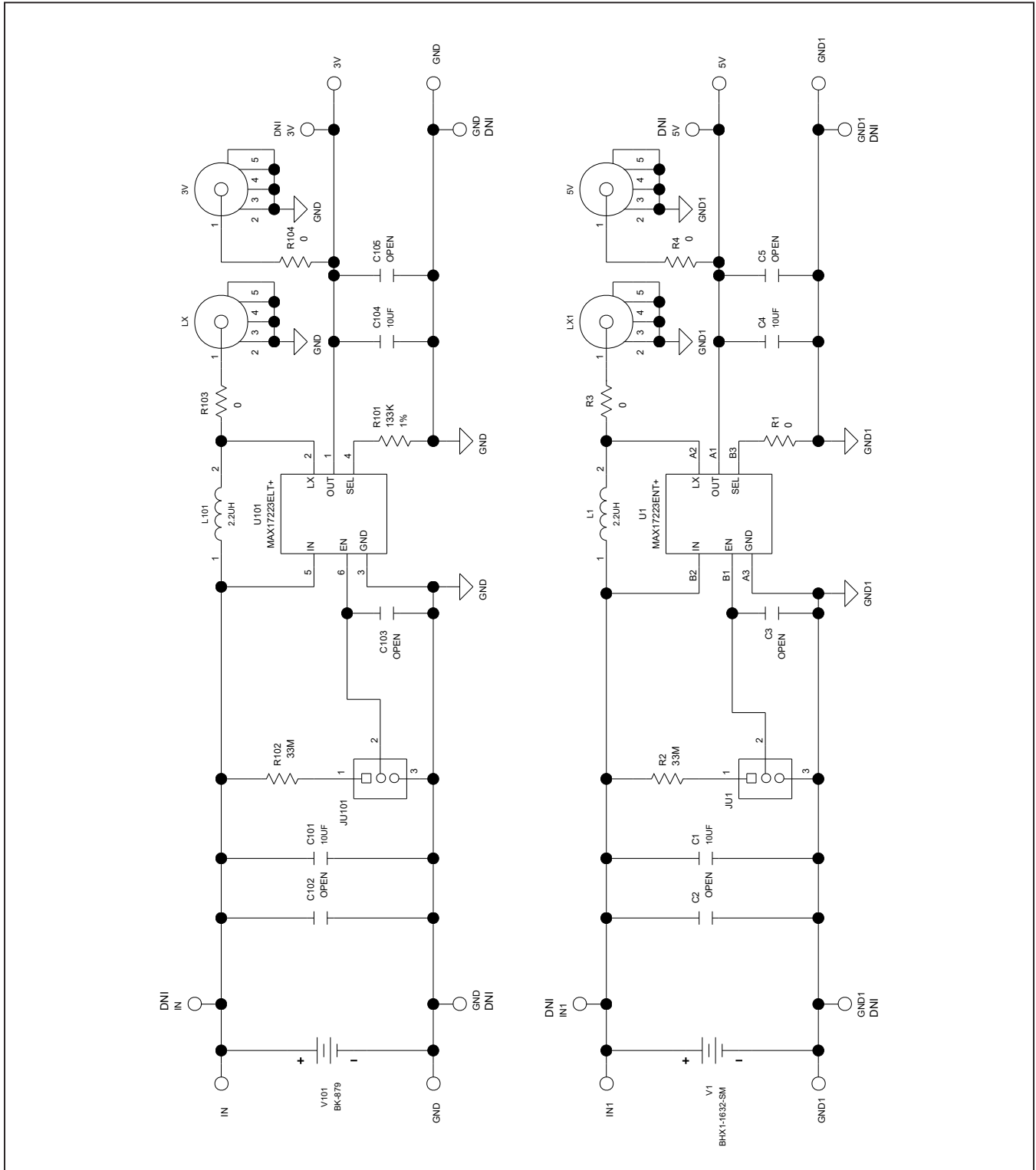

MAX17223 Minimal Component Circuit Schematic

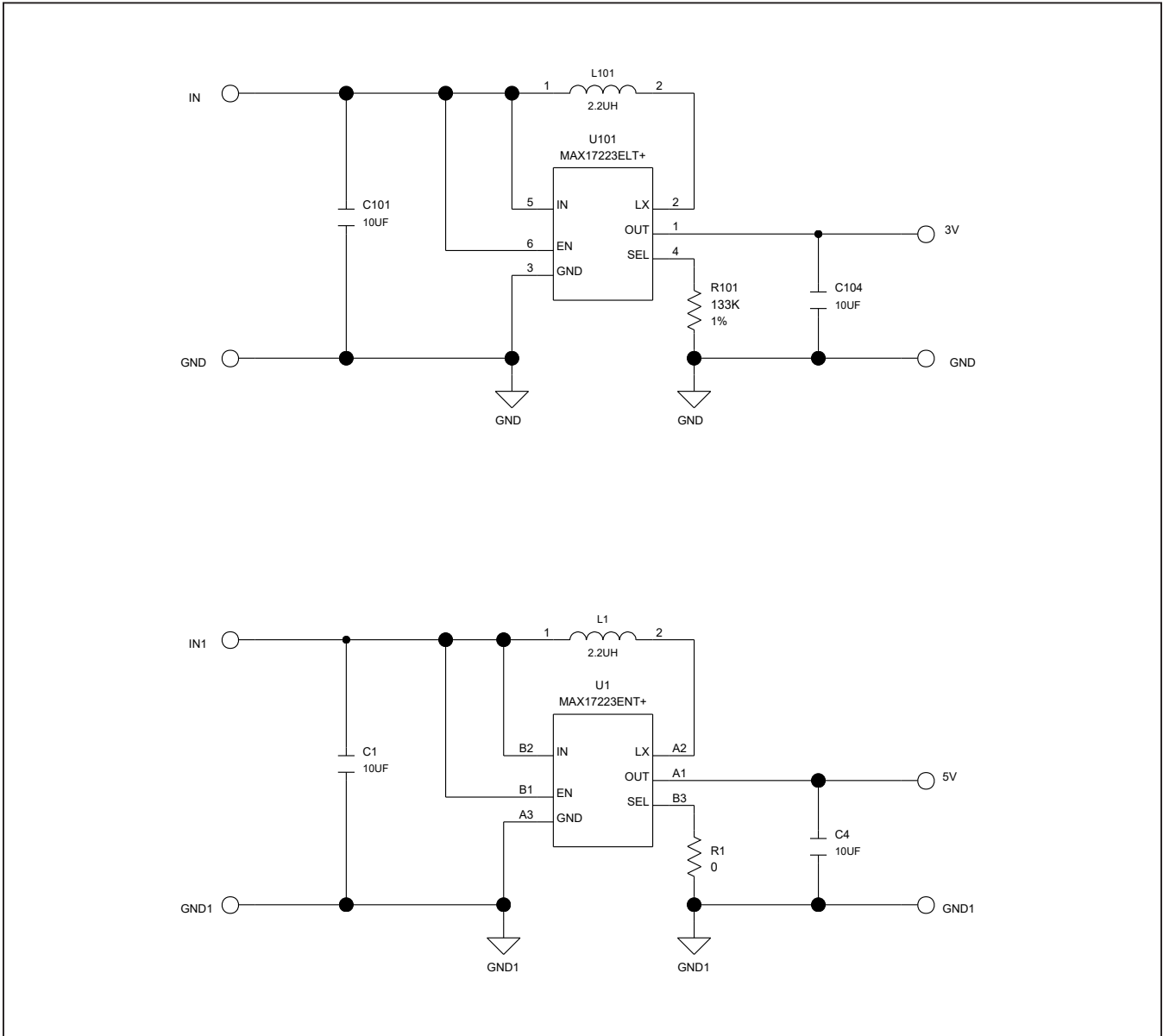

MAX17223 EV Kit PCB Layout Diagrams

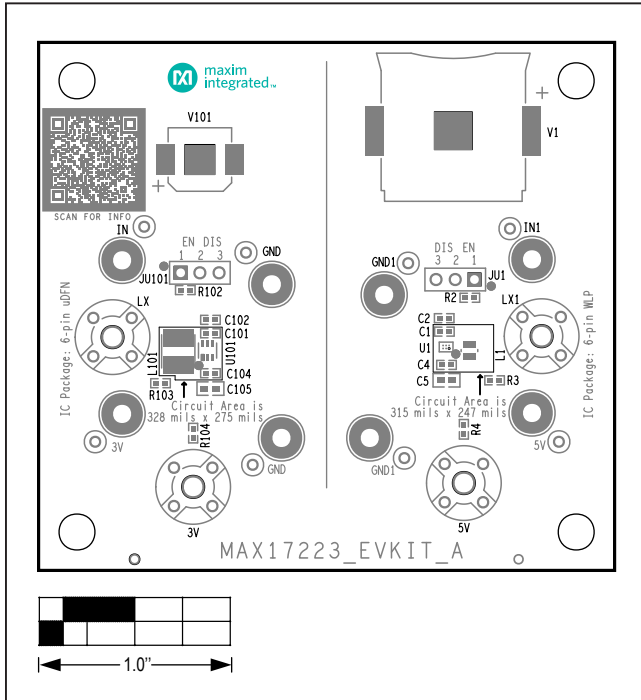

MAX17223 EV Kit—Top Silkscreen

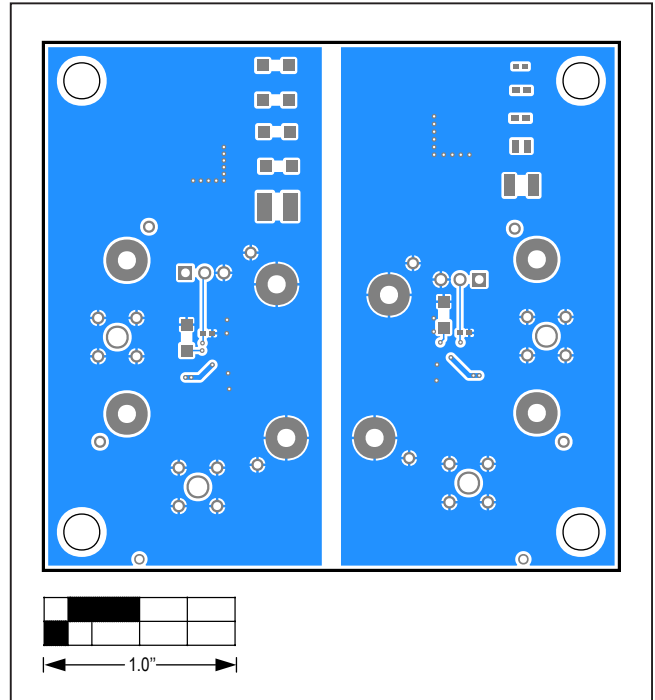

MAX17223 EV Kit—Bottom

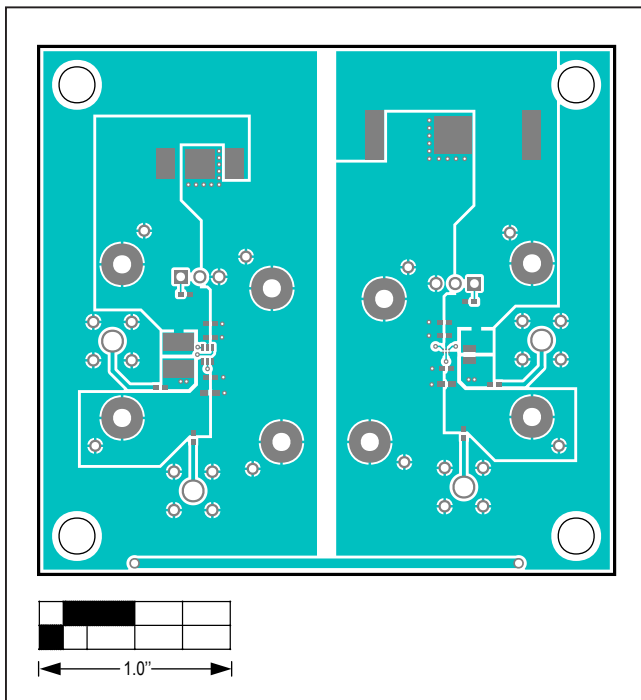

MAX17223 EV Kit—Top

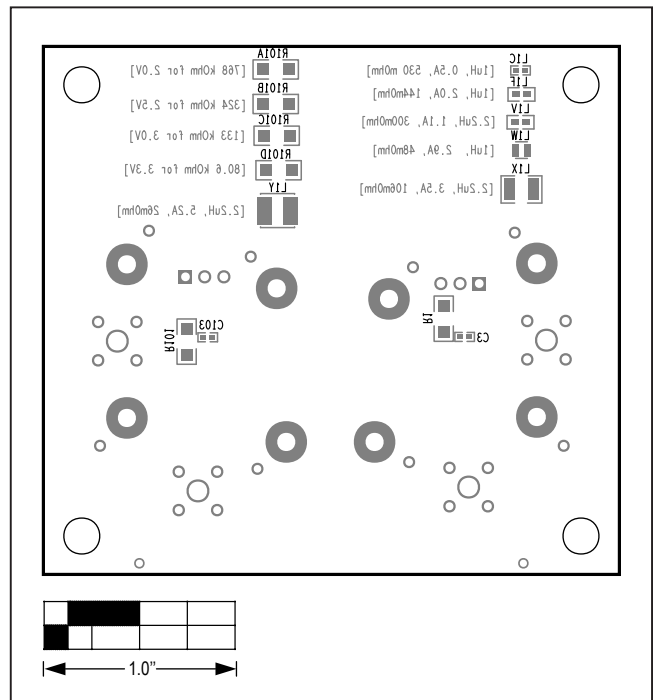

MAX17223 EV Kit—Bottom Silkscreen

Revision History

REVISION NUMBER	REVISION DATE	DESCRIPTION	PAGES CHANGED
0	9/20	Initial release	—
1	9/20	Replaced TDFN with μ DFN	2

For pricing, delivery, and ordering information, please visit Maxim Integrated's online storefront at <https://www.maximintegrated.com/en/storefront/storefront.html>.

Maxim Integrated cannot assume responsibility for use of any circuitry other than circuitry entirely embodied in a Maxim Integrated product. No circuit patent licenses are implied. Maxim Integrated reserves the right to change the circuitry and specifications without notice at any time.