

Evaluates: MAX20345

MAX20345 Evaluation System

General Description

The MAX20345 evaluation system (EV system) is a fully assembled and tested circuit board that demonstrates the MAX20345 ultra low-power wearable power management integrated circuit (PMIC).

The MAX20345 is a battery-charge-management solution ideal for low-power wearable applications. The device includes voltage regulators such as bucks, boost, buck-boost, and linear regulators, as well as a battery management solution with battery seal, linear battery charger, and smart power path selector.

The MAX20345 EV system comes with the MAX20345_SYS_EVKIT_B board, the PICO2PMB# board, and two micro-B cables. The EV system has the MAX20345AEWN+ installed. The device is configurable through an I²C interface that allows for programming various functions and reading the device status. The application sends commands to the MAXPICO2PMB USB-to-I²C adapter board to configure the MAX20345.

Features

- USB-Power Option
- Flexible Configuration
- On-Board Battery Simulation
- Sense Test Point for Output-Voltage Measurement
- Windows® 8/Windows 10-Compatible Graphical User Interface (GUI) Software
- Fully Assembled and Tested

EV Kit Contents

- MAX20345_SYS_EVKIT_B System
- MAXPICO2PMB# board
- Two USB A to USB micro-B cables

PICO2PMB Adapter Board Photo

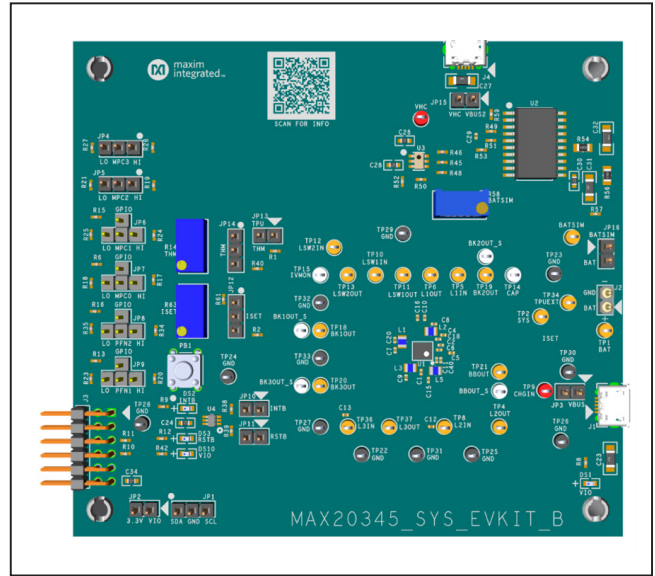

Figure 1. MAX20345_SYS_EVKIT_B

MAX20345 EV KIT Files

| FILE | DESCRIPTION |
|----------------------------|----------------|
| MAX20345EVKitSetupVxxx.exe | PC GUI Program |

[Ordering Information](#) appears at end of data sheet.

Windows is a registered trademark of Microsoft Corporation.

319-100843; Rev 0; 11/21

Quick Start

Required Equipment

- MAX20345 EV System
- Windows PC with USB ports
- One USB A-to-USB micro-B cable and a PICO2PMB adapter board with the latest firmware
- One USB A-to-USB micro-B cable or a power supply (for battery simulation or battery voltage)
- (Optional) One USB A-to-USB Micro-B Cable or power supply (for charger input CHGIN)
- One voltmeter

Note: In the following sections, software-related items are identified by bold text. Text in **bold** refers to items directly from the EV system software. Text which is **bold and underlined** refers to items from the Windows operating system.

Procedure

The EV system is fully assembled and tested. Follow the steps to verify board operation.

- 1) Visit <https://www.maximintegrated.com> to download the latest version of the EV system software, MAX20345EVKitSetupVxxx.zip, located on the MAX20345 EV system web page. Download the EV system software to a temporary folder and unzip the zip file.
- 2) Install the EV System software on your computer by running the MAX20345EVKitSetupVxxx.exe program inside the temporary folder.
- 3) Verify that all jumpers are in their default positions, as shown in [Table 1](#).
- 4) Connect the USB type-A end of the cable to the PC and the micro-USB end of the cable to the MAXPICO2PMB# board, then connect the MAXPICO2PMB# to J3 located on lower left of the EV kit board.
- 5) Connect the USB A to micro-B cable from the computer to J4 on the upper right corner of the EV kit board to use VBUS to power the battery simulation circuits on the board, or power the battery simulation circuits from the VHC test point. (Use a Li-ion battery or power source to evaluate the device if not using the battery simulation circuits. Connect the battery or power source to J2 on the EV kit board. Skip step 7 if not using the battery simulation.)
- 6) Use a voltmeter to check that VHC is approximately 5V and that the BATSIM test point is approximately 3.7V. To adjust the BATSIM voltage, turn the R58 BATSIM potentiometer. Place shunt on JP16, then confirm that TP1 BAT is the set BATSIM voltage.
- 7) On the computer, open the MAX20345 Evaluation Kit Tool GUI. The status bar on the bottom of the EV Kit Tool software shows “Not Connected” as seen in [Figure 2](#).
- 8) In order to use the MAXPICO2PMB with the MAX20345 EV Kit Tool, click on Device on the GUI toolbar, choose the **Advance** option, and finally select Use **MAXPICO2PMB** ([Figure 2](#)).
- 9) The status of the EV Kit Tool now shows “Connected”. Upon successful connection, the device info populates in the EV kit software ([Figure 3](#)).

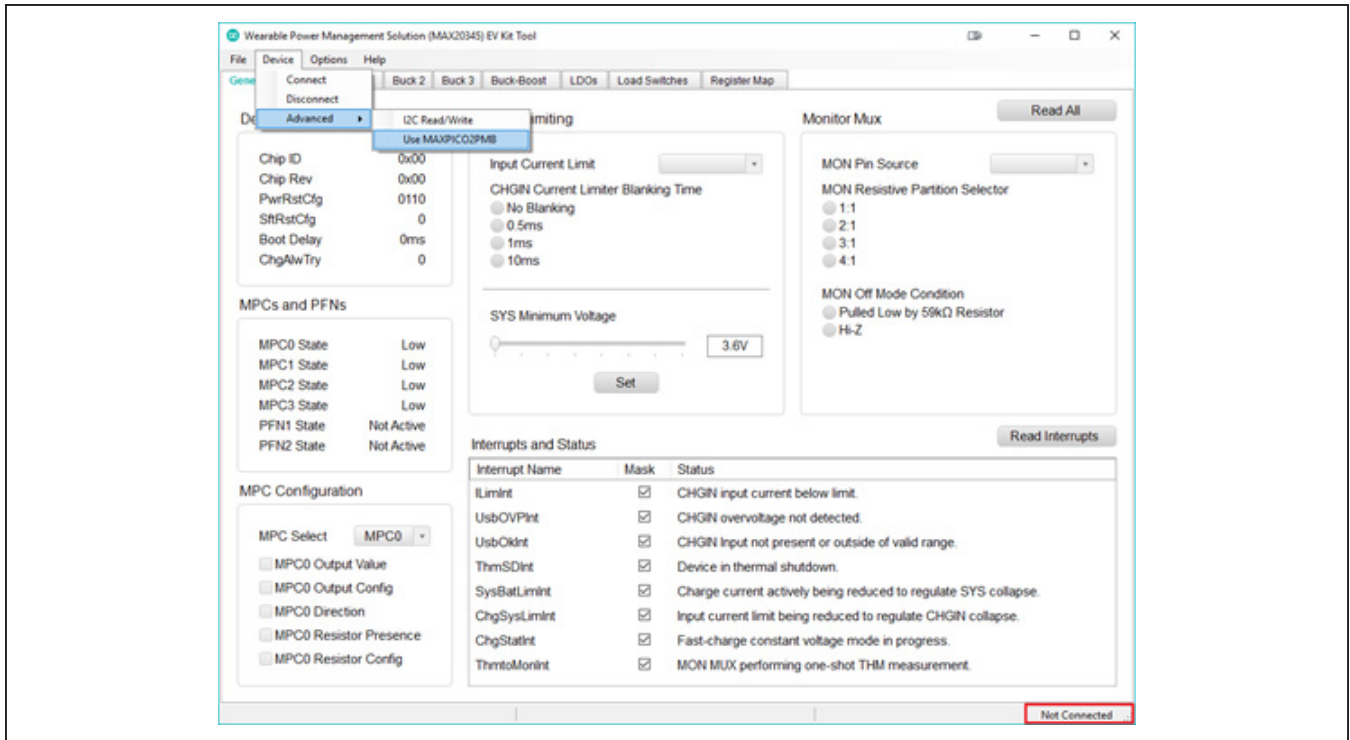

Figure 2. Configuring the EV Kit Tool with MAXPICO2PMB Adapter Board

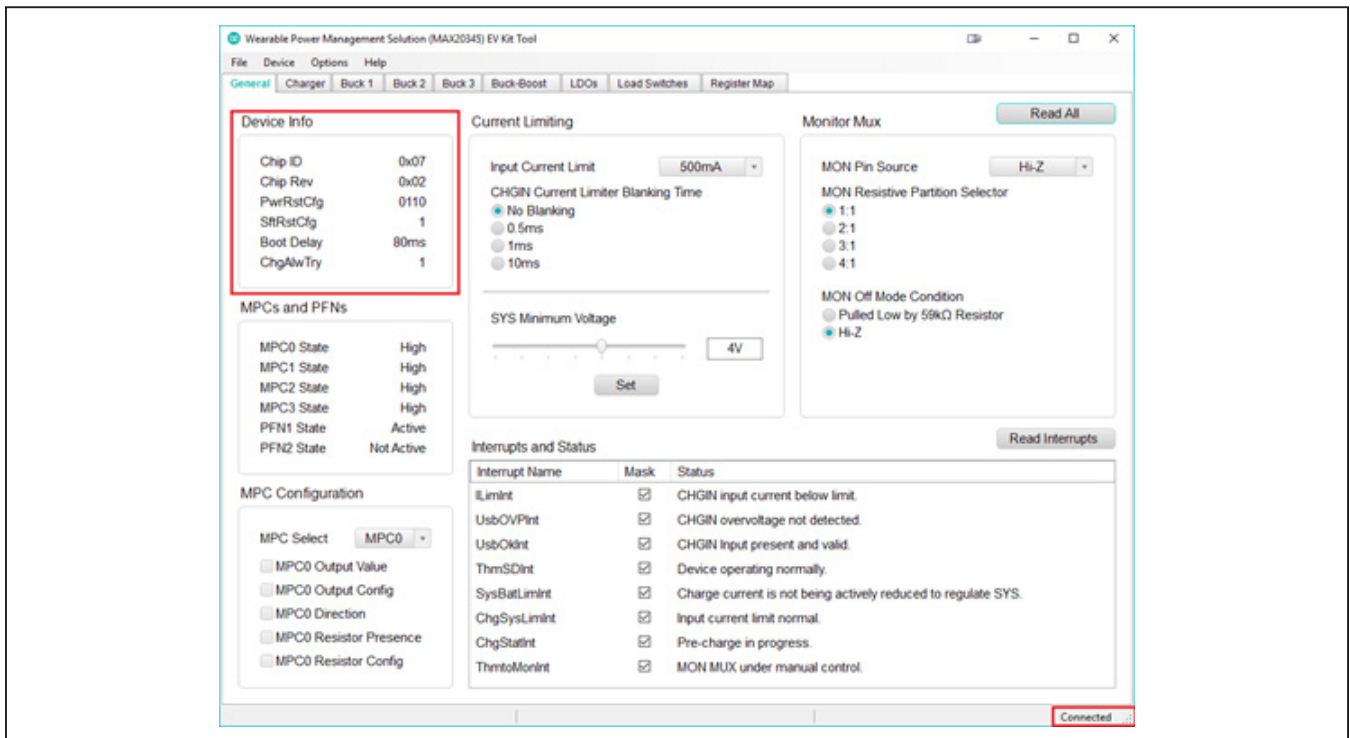

Figure 3. General Tab, MAX20345_SYS_EVKIT_B is Connected to EV Kit Tool

Detailed Description of Software

Software Startup

After opening the application, make sure that “Connected” is shown in the status strip at the bottom of the window. If any other message is displayed, check all connections, and verify that the steps in the Procedure section were followed in the correct order.

At startup, the user is presented with the **General** tab. This tab shows some basic information about the MAX20345 and provides access to general configuration options.

The **Read All** button reads all the configuration registers that are visible on the current tab page.

All configuration tabs have an Interrupt and Status section that shows the user the state of the status registers and their corresponding interrupts. By checking or unchecking the **Mask** option, the user can control which interrupts cause the INT output to be pulled low when asserted. Clicking the **Read Interrupts** button reads and clears the interrupts visible in the current tab. Asserted interrupts are denoted by bold text in the **Interrupt Name** field. All statuses are polled every 500ms. The polling feature can be disabled in the **Options** section of the menu bar by selecting **Disable Polling**.

In the general tab, the user can adjust the input current limit, adjust the minimum SYS voltage, configure the MON Mux, see the MPC/PFN input states, and more.

The tabs along the top provide access to configurations and status information for the Li+ charger and the five voltage regulators. The **Register Map** tab provides access to all I²C configuration registers, some of which are not available in other tabs.

Detailed descriptions of all configuration registers can be found in the MAX20345 datasheet.

Charger Tab

The **Charger** tab contains configuration options for the Li+ battery charger. The **Charger** configuration tab layout is shown in [Figure 4](#).

The **Charger** tab is much like all other tabs; the write command is sent immediately when the state of the toggle, dropdown, or button changes. From the **Charger** tab, the user can enable/disable the charger and adjust any of the charger settings like the battery regulation threshold, the precharge voltage threshold, etc.

Detailed descriptions of all registers in the Charger configuration tab can be found in the MAX20345 datasheet.

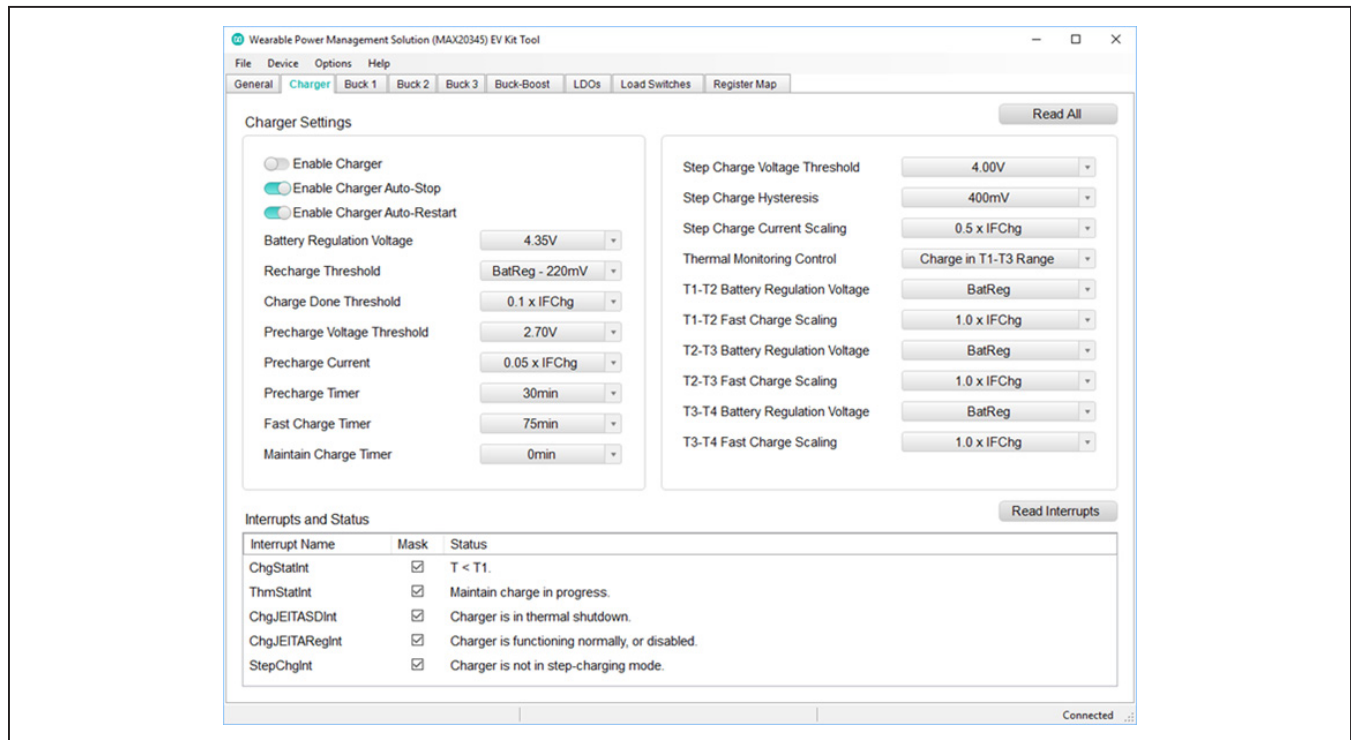

Figure 4. Charger Tab

Regulator Tabs

The **Buck 1-3, Buck-Boost, LDOs, and Load Switches** tabs contain configuration options for the voltage regulators and load switches. All regulator tabs share the same basic layout. The **Buck 1** configuration tab is shown in [Figure 5](#).

From the regulator tabs, the user can enable/disable the regulator, adjust the regulator voltage, adjust the inductor peak current, and configure the various operation modes of the regulator.

Changing a register setting is as easy as clicking the corresponding toggle or radio button. The I²C write command is sent immediately when the state of the toggle, dropdown, or button changes.

The output voltage and peak current settings can be changed by adjusting the slider or by simply typing the voltage or current in the text box. The I²C write command is sent when the user clicks the **Set** button.

Detailed descriptions of all regulator configuration registers can be found in the MAX20345 data sheet.

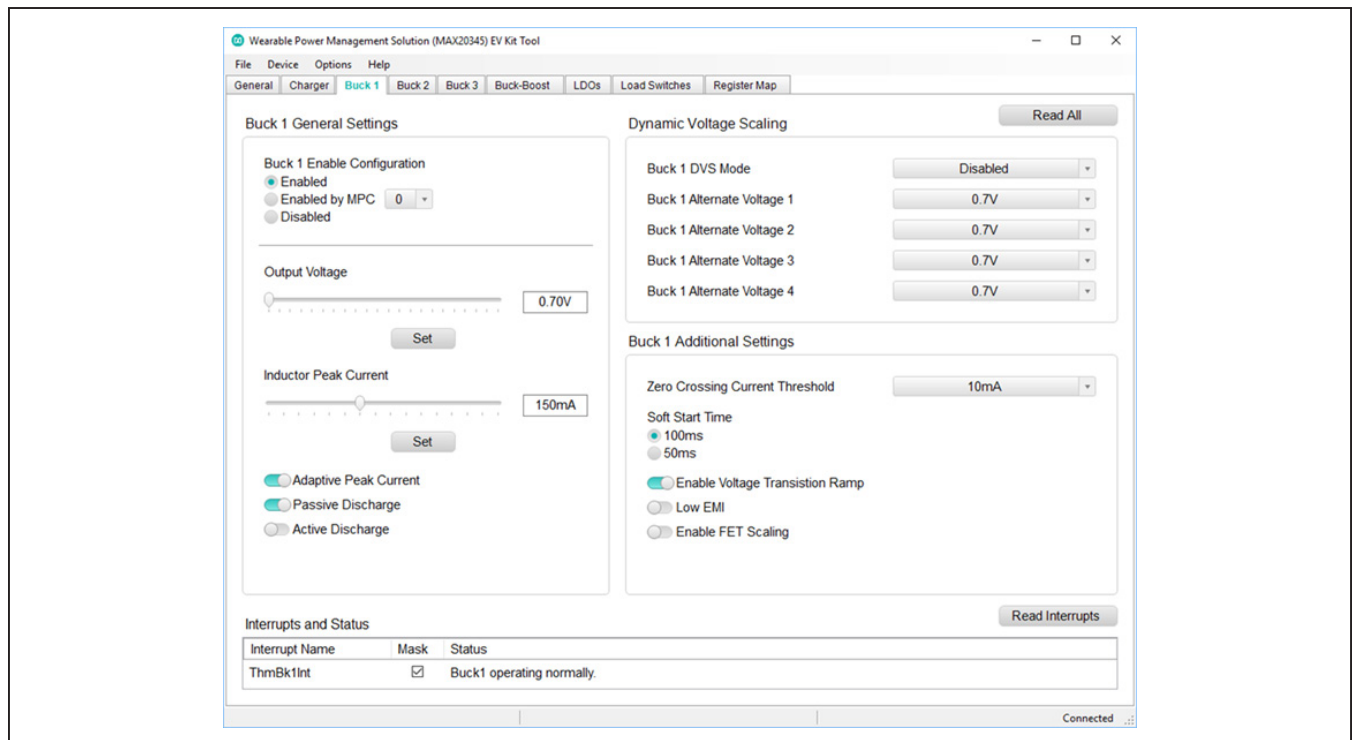

Figure 5. Buck 1 Tab

Register Map Tab

The **Register Map** tab allows for the configuration of all I2C registers, including those not configurable in other tabs. This tab can be resized or maximized to make reading the register descriptions easier. The **Register Map** tab layout is shown in [Figure 6](#).

The register to be read from or written to can be selected in the **I2C Registers** table. The right table contains descriptions for each bit of the selected 8-bit register. At the bottom of the page, all register bits are displayed along with their field names. To set a bit, click the bit label. Bold text represents logic 1 and regular text represents

logic 0. To commit the changes to the device, click the **Write** button in the bottom right of the tab page.

To read or write I2C registers that are not included in the register map, select **Device** from the menu bar at the top of the application. Navigate to **Advanced > I2C Read/Write** to open the generic I2C Read/Write window. To write to a register, enter the 8-bit slave address (including a LSB of zero for the write bit) and the register address in hex then click **Write**. To read from a register, enter the 8-bit slave address (including a LSB of zero even though it is a read) and the register address in hex and click **Read**.

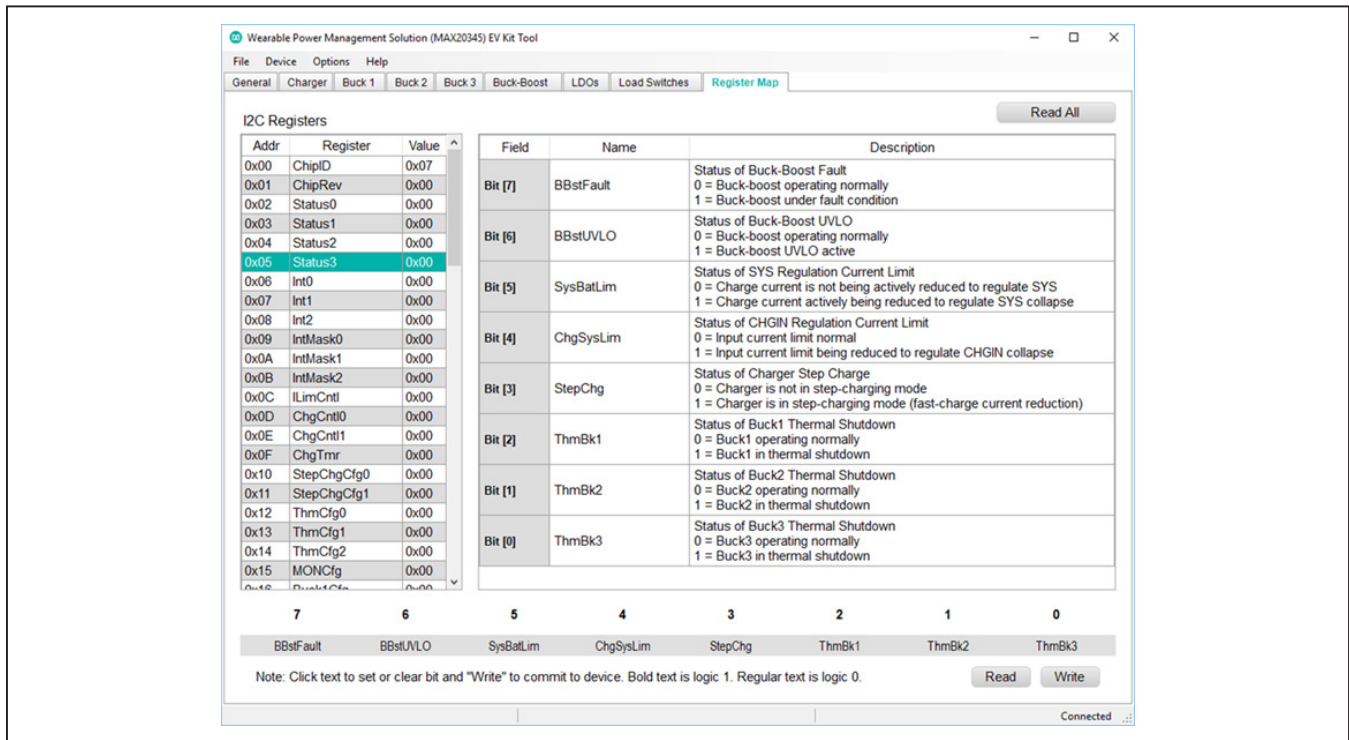

Figure 6. Register Map Tab

Detailed Description of Hardware

To use the EV kit with the EV kit software, connect the MAXPICO2PMB# to the PMOD connector in the bottom left corner of the board. The MAXPICO2PMB# also provides 3.3V to the logic voltage VIO of the EV kit when shunting JP2. Use the JP2 USB VBUS to power the battery simulation circuits on the EV kit to supply BAT of the IC. Turning the R58 (BATSIM) potentiometer can change the BATSIM voltage. Connect BATSIM to BAT of the IC with shunt on JP16. Alternatively, instead of using battery simulation circuits on the board, connect a Li-ion battery on J2 connector. Use the J1 USB VBUS as CHGIN source and place shunt on JP3.

PFNs and MPCs States

The PFNs and MPCs can be pulled up to VIO or connected to ground through a 100kΩ resistor.

Regulators and Peripherals

All regulator outputs are made available on test points. The inputs to the LDO1, LDO2, LDO3, Load Switch 1, and Load Switch 2 must be supplied externally through test points. Bucks, buck-boost, and boost output have sense test points which provide easy voltage measurement.

Thermistor and SET Adjustment

When the JP13 shunt is installed, THM is pulled up to TPU through a 10kΩ resistor. Header JP14 is used to select the pull-down resistor for THM. When pin 1 and 2 are shunted, potentiometer R14 is used to simulate a thermistor at THM. When pins 2 and 3 are shunted, a fixed 10kΩ resistor is connected between THM and ground.

Header JP12 is used to select the resistor for RISET which sets the fast-charge current IFCHG. Shunting pins 1 and 2 selects potentiometer R63. Change RISET to change IFCHG. Shunting pins 2 and 3 selects a fixed 10kΩ resistor, which sets fast-charge current to 0.2A.

The charge current value is determined as:

$$I_{FCHG} = K_{SET} \times V_{SET}/R_{SET}$$

Where K_{SET} has a typical value of 2000A/A and V_{SET} has a typical value of +1V.

INT and RST LED Indicators

Shunts can be installed on JP10 and JP11 to show the status of INT and RST as LED indicators DS2 and DS3. When the corresponding LED illuminates, it verifies that the active-low output is pulled low.

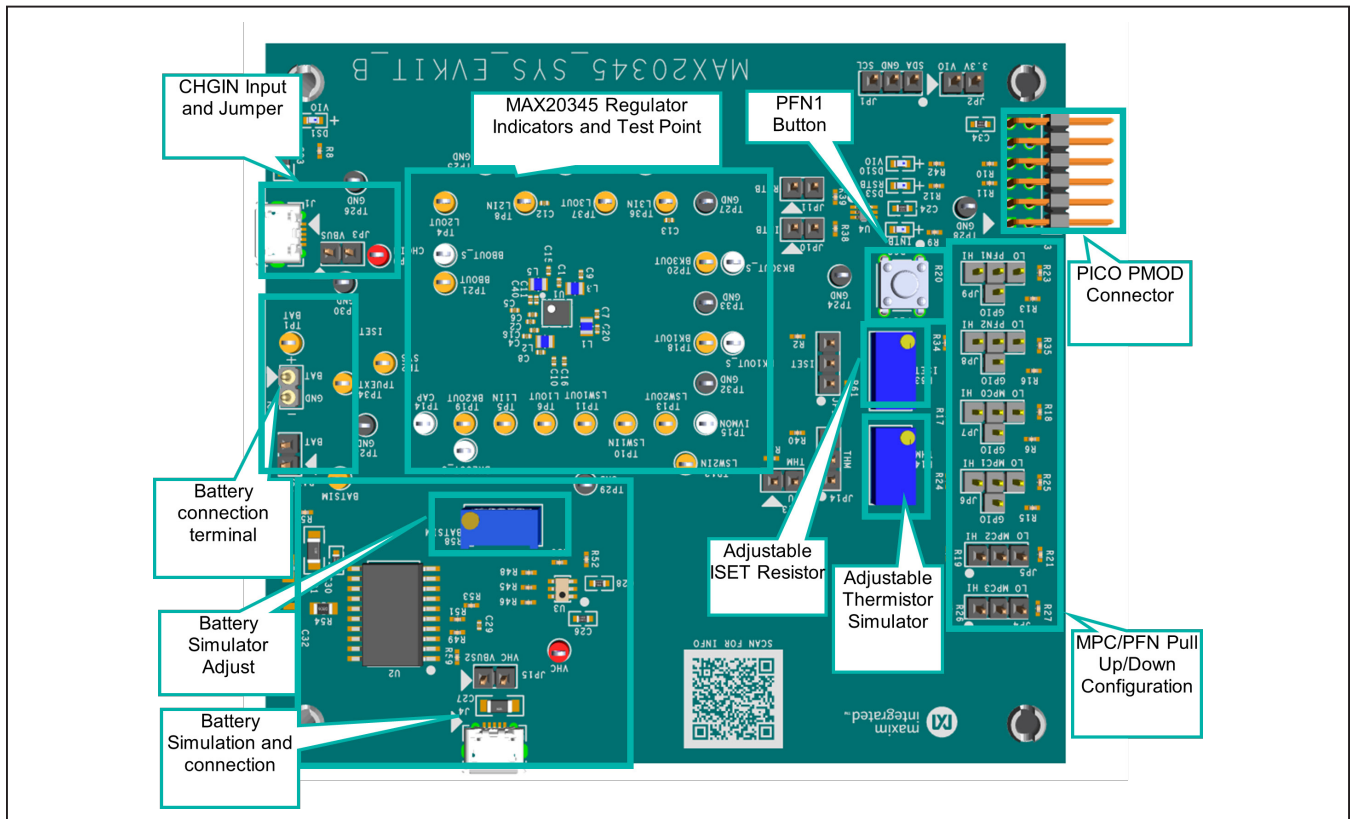

Figure 7. MAX20345_SYS_EVKIT_B

Table 1. Jumper Table (J1-J3)

| JUMPER | SHUNT POSITION | DESCRIPTION |
|--------|----------------|---|
| JP1 | 1-2 | SDA connect to ground |
| | 2-3 | SCL connect to ground |
| JP2 | 1-2* | VIO connect to 3.3V from PMOD |
| JP3 | 1-2 | CHGIN connect to USB VBUS from J1 |
| JP4 | 1-2 | MPC3 pull up to VIO |
| | 2-3 | MPC3 pull down to ground |
| JP5 | 1-2 | MPC2 pull up to VIO |
| | 2-3 | MPC2 pull down to ground |
| JP6 | 1-2 | MPC1 pull down to ground |
| | 1-3 | MPC1 connect to GPIO4 |
| | 1-4 | MPC1 pull up to VIO |
| JP7 | 1-2 | MPC0 pull down to ground |
| | 1-3 | MPC0 connect to GPIO3 |
| | 1-4 | MPC0 pull up to VIO |
| JP8 | 1-2 | PFN2 pull down to ground |
| | 1-3 | PFN2 connect to GPIO2 |
| | 1-4 | PFN2 pull up to VIO |
| JP9 | 1-2 | PFN1 pull down to ground |
| | 1-3 | PFN1 connect to GPIO1 |
| | 1-4 | PFN1 pull up to VIO |
| JP10 | 1-2* | INT connect to pull up VIO and DS2 |
| JP11 | 1-2* | RST connect to pull up VIO and DS3 |
| JP12 | 1-2 | ISET connect to potentiometer |
| | 2-3* | ISET connect to 10kΩ (fast-charge current 0.2A) |
| JP13 | 1-2* | THM connect to TPU for thermistor monitoring |
| JP14 | 1-2 | THM connect to potentiometer |
| | 2-3* | THM connect to 10kΩ (50%/room zone) |
| JP15 | 1-2* | VHC connect to USB VBUS2 from JP3 |
| JP16 | 1-2* | BATSIM connect to BAT |

*Default position.

Table 2. Connectors Description

| CONNECTOR | DESCRIPTION |
|-----------|---|
| J1 | Connect to USB cable for CHGIN voltage |
| J2 | Connect to battery |
| J3 | Connect to MAXPICO2PMB# |
| J4 | Connect to the USB cable for battery simulation |

MAXPICO2PMB Firmware Update

This section covers the procedure to update the PICO2PMB Adapter Board with the latest firmware by programming a firmware image file (.bin) onto the onboard MAX32625PICO microcontroller.

- 1) Put the board in maintenance mode by holding the button while the board is connecting to the computer. It might be easier to hold the button while inserting the USB cable at the computer end rather than the micro USB connector end (see [Figure 8](#)).
- 2) If the board enters bootloader mode successfully, the LED on the board turns red and the board appears to the computer as a USB drive named **MAINTENANCE**.
- 3) Drag and drop the firmware image file (.bin) into the **MAINTENANCE** drive and the board then installs the new firmware.



Figure 8. Enter Maintenance Mode on the MAX32625PICO

Ordering Information

| PART | TYPE |
|----------------|--------|
| MAX20345EVSYS# | EV Kit |

#Denotes RoHS compliant.

MAX20345 EV Kit Bill of Materials

| ITEM | REF_DES | DNI/DNP | QTY | MFG PART # | MANUFACTURER | VALUE | DESCRIPTION | COMMENTS |
|------|--|---------|-----|---|--|----------------------|---|----------|
| 1 | BATSIM, TP1, TP2, TP4-TP6, TP8, TP10-TP13, TP18-TP21, TP34, TP36, TP37 | - | 18 | 5003 | KEYSTONE | N/A | TEST POINT; PIN DIA=0.1IN; TOTAL LENGTH=0.3IN; BOARD HOLE=0.04IN; ORANGE; PHOSPHOR BRONZE WIRE SILVER PLATE FINISH; | |
| 2 | BBOUT_S, BK1OUT_S- BK3OUT_S, TP14, TP15 | - | 6 | 5002 | KEYSTONE | N/A | TEST POINT; PIN DIA=0.1IN; TOTAL LENGTH=0.3IN; BOARD HOLE=0.04IN; WHITE; PHOSPHOR BRONZE WIRE SILVER; | |
| 3 | C1, C4, C13 | - | 3 | C1005X5R0J225K050BC; CL05A225KQ5NSN | TDK;SAMSUNG | 2.2UF | CAP; SMT (0402); 2.2UF; 10%; 6.3V; X5R; CERAMIC | |
| 4 | C2 | - | 1 | C1005X5R1V225K050BC | TDK | 2.2UF | CAP; SMT (0402); 2.2UF; 10%; 35V; X5R; CERAMIC | |
| 5 | C5 | - | 1 | C1005X7S1A225K050BC | TDK | 2.2UF | CAP; SMT (0402); 2.2UF; 10%; 10V; X7S; CERAMIC | |
| 6 | C6-C9, C11, C18, C20, C40 | - | 8 | GRM155R60J226ME11 | MURATA | 22UF | CAP; SMT (0402); 22UF; 20%; 6.3V; X5R; CERAMIC; | |
| 7 | C10, C12, C15, C16 | - | 4 | C1005X5R0J475K050BC | TDK | 4.7UF | CAP; SMT (0402); 4.7UF; 10%; 6.3V; X5R; CERAMIC | |
| 8 | C23, C27 | - | 2 | GRM31CR71H475KA12; GRJ31CR71H475KE11; GXM31CR71H475KA10; UMK316AB7475KL; GRM31CR71H475KA12L | MURATA;MURATA;MURATA; TAIYO YUDEN;MURATA | 4.7UF | CAP; SMT (1206); 4.7UF; 10%; 50V; X7R; CERAMIC | |
| 9 | C24 | - | 1 | C1608X5R1H104K080AA | TDK | 0.1UF | CAP; SMT (0603); 0.1UF; 10%; 50V; X5R; CERAMIC | |
| 10 | C26 | - | 1 | C0603C225K9PAC; GRM188R60J225KE01; C1608X5R0J225K080AB | KEMET;MURATA;TDK | 2.2UF | CAP; SMT (0603); 2.2UF; 10%; 6.3V; X5R; CERAMIC; | |
| 11 | C28 | - | 1 | C0603C475K9PAC | KEMET | 4.7UF | CAP; SMT (0603); 4.7UF; 10%; 6.3V; X5R; CERAMIC; | |
| 12 | C29 | - | 1 | C0402X7R500-222KNE; GRM155R71H222KA01; C1005X7R1H222K050BA | VENKEL LTD.;MURATA;TDK | 2200PF | CAP; SMT (0402); 2200PF; 10%; 50V; X7R; CERAMIC | |
| 13 | C30 | - | 1 | C0603C104K8RAC | KEMET | 0.1UF | CAP; SMT (0603); 0.1UF; 10%; 10V; X7R; CERAMIC | |
| 14 | C31 | - | 1 | C3216X5R1C476M160AB; GRM31CR61C476ME44 | TDK;MURATA | 47UF | CAP; SMT (1206); 47UF; 20%; 16V; X5R; CERAMIC | |
| 15 | C32 | - | 1 | C3216X5R1H106K160AB; GRM31CR61H106KA12 | TDK;MURATA | 10UF | CAP; SMT (1206); 10UF; 10%; 50V; X5R; CERAMIC | |
| 16 | C34 | - | 1 | GRM188R60J105KA01 | MURATA | 1UF | CAP; SMT (0603); 1UF; 10%; 6.3V; X5R; CERAMIC; | |
| 17 | DS1-DS3, DS10 | - | 4 | LG L29K-G2J1-24 | OSRAM | LG L29K-G2J1-24 | DIODE; LED; SMT (0603); Vf=1.7V; If(test)=0.002A; -40 DEGC TO +100 DEGC | |
| 18 | J1, J4 | - | 2 | ZX62D-B-5P8 | HIROSE ELECTRIC CO LTD. | ZX62D-B-5P8 | CONNECTOR; MALE; SMT; MICRO UNIVERSAL SERIES BUS B-TYPE CONNECTOR; RIGHT ANGLE; 5PINS | |
| 19 | J2 | - | 1 | 800-10-002-10-001000 | MILLMAX | 800-10-002-10-001000 | CONNECTOR; MALE; TH; SINGLE ROW; STRAIGHT; 2PINS | |
| 20 | J3 | - | 1 | PBC06DBAN | SULLINS ELECTRONICS CORP. | PBC06DBAN | CONNECTOR; MALE; THROUGH HOLE; BREAKAWAY; RIGHT ANGLE; 12PINS; 12PINS - ALTERNATE PIN NUMBERING | |
| 21 | JP1, JP4, JP5, JP12, JP14 | - | 5 | PBC03SAAN | SULLINS | PBC03SAAN | CONNECTOR; MALE; THROUGH HOLE; BREAKAWAY; STRAIGHT; 3PINS; -65 DEGC TO +125 DEGC | |
| 22 | JP2, JP3, JP10, JP11, JP13, JP15, JP16 | - | 7 | PBC02SAAN | SULLINS ELECTRONICS CORP. | PBC02SAAN | CONNECTOR; MALE; THROUGH HOLE; BREAKAWAY; STRAIGHT; 2PINS | |
| 23 | JP6-JP9 | - | 4 | TSW-104-07-L-S | SAMTEC | TSW-104-07-L-S | EVKIT PART-CONNECTOR; MALE; THROUGH HOLE; TSW SERIES; SINGLE ROW; STRAIGHT; 4PINS | |
| 24 | L1-L3, L5 | - | 4 | DFE201612E-2R2M | MURATA | 2.2UH | INDUCTOR; SMT (0806); WIREWOUND CHIP; 2.2UH; TOL=+/-20%; 1.8A | |
| 25 | MISC1 | - | 1 | MAXPICO2PMB# | MAXIM | MAXPICO2PMB# | ACCESSORY; BRD; PACKOUT; MAXPICO2PMB ADAPTER BOARD | |
| 26 | PB1 | - | 1 | 1825910-6 | TE CONNECTIVITY | 1825910-6 | SWITCH; SPST; THROUGH HOLE; 24V; 0.05A; TACTILE SWITCH; RCOIL=0 OHM; RINSULATION=100M OHM; TE CONNECTIVITY | |
| 27 | R1, R2, R10, R11, R38-R40, R49, R53 | - | 9 | RC0402FR-0710KL | YAGEO PHICOMP | 10K | RES; SMT (0402); 10K; 1%; +/-100PPM/DEGC; 0.0630W | |

MAX20345 EV Kit Bill of Materials (continued)

| ITEM | REF_DES | DNI/DNP | QTY | MFG PART # | MANUFACTURER | VALUE | DESCRIPTION | COMMENTS |
|-------|---|---------|-----|-----------------------------|---------------------------------------|---------------|--|----------|
| 28 | R6, R13, R15, R16 | - | 4 | ERJ-2RKF1001 | PANASONIC | 1K | RES; SMT (0402); 1K; 1%; +/-100PPM/DEGC; 0.1000W | |
| 29 | R8, R9, R12, R42 | - | 4 | CRCW0402499RFK | VISHAY DALE | 499 | RES; SMT (0402); 499; 1%; +/-100PPM/DEGC; 0.0630W | |
| 30 | R14, R63 | - | 2 | PV36Y105C01B00 | MURATA | 1M | RESISTOR; THROUGH-HOLE-RADIAL LEAD; PV36 SERIES; 1M OHM; 10%; 100PPM; 0.5W; TRIMMER POTENTIOMETER; 25 TURNS; MOLDER CERAMIC OVER METAL FILM | |
| 31 | R17-R21, R23-R27, R34, R35, R45, R46, R48, R50, R57 | - | 17 | ERJ-2GEJ104 | PANASONIC | 100K | RES; SMT (0402); 100K; 5%; +/-200PPM/DEGC; 0.1000W | |
| 32 | R51 | - | 1 | ERJ-2GE0R00 | PANASONIC | 0 | RES; SMT (0402); 0; JUMPER; JUMPER; 0.1000W | |
| 33 | R52 | - | 1 | ERJ-2RKF5100 | PANASONIC | 510 | RES; SMT (0402); 510; 1%; +/-100PPM/DEGC; 0.1000W | |
| 34 | R54, R56 | - | 2 | WSL0805R1000FEA18 | VISHAY DALE | 0.1 | RES; SMT (0805); 0.1; 1%; +/-75PPM/DEGC; 0.1250W | |
| 35 | R58 | - | 1 | 3296Y-1-253LF | BOURNS | 25K | RESISTOR; THROUGH-HOLE-RADIAL LEAD; 3296 SERIES; 25K OHM; 10%; 100PPM; 0.5W; SQUARE TRIMMING POTENTIOMETER; 25 TURNS; MOLDER CERAMIC OVER METAL FILM | |
| 36 | R59 | - | 1 | ERJ-2RKF1152 | PANASONIC | 11.5K | RES; SMT (0402); 11.5K; 1%; +/-100PPM/DEGC; 0.1000W | |
| 37 | R61 | - | 1 | CRCW04023K40FK | VISHAY DALE | 3.4K | RES; SMT (0402); 3.4K; 1%; +/-100PPM/DEGC; 0.0630W | |
| 38 | SPACER1-SPACER4 | - | 4 | 9032 | KEYSTONE | 9032 | MACHINE FABRICATED; ROUND-THRU HOLE SPACER; NO THREAD; M3.5; 5/8IN; NYLON | |
| 39 | SU1-SU16 | - | 16 | S1100-B;SX1100-B; STC02SYAN | KYCON;KYCON;SULLINS ELECTRONICS CORP. | SX1100-B | TEST POINT; JUMPER; STR; TOTAL LENGTH=0.24IN; BLACK; INSULATION=PBT;PHOSPHOR BRONZE CONTACT=GOLD PLATED | |
| 40 | TP9_VHC | - | 2 | 5000 | KEYSTONE | N/A | TEST POINT; PIN DIA=0.1IN; TOTAL LENGTH=0.3IN; BOARD HOLE=0.04IN; RED; PHOSPHOR BRONZE WIRE SILVER PLATE FINISH; | |
| 41 | TP22-TP33 | - | 12 | 5001 | KEYSTONE | N/A | TEST POINT; PIN DIA=0.1IN; TOTAL LENGTH=0.3IN; BOARD HOLE=0.04IN; BLACK; PHOSPHOR BRONZE WIRE SILVER PLATE FINISH; | |
| 42 | U1 | - | 1 | MAX20345AEWN+ | MAXIM | MAX20345AEWN+ | EVKIT PART - IC; PMIC WITH ULTRA-LOW IQ VOLTAGE REGULATORS; OHR DRIVER AND CHARGER FOR SMALL LITHIUM ION SYSTEMS; WLP 56 PINS; 0.4MM PITCH; PACKAGE CODE: W563H3+1; PACKAGE OUTLINE DRAWING: 21-100260 | |
| 43 | U2 | - | 1 | OPA569AIDWPR | TEXAS INSTRUMENTS | OPA569AIDWPR | IC; AMP; RAIL-TO-RAIL I/O; POWER AMPLIFIER; WSOIC20-EP 300MIL | |
| 44 | U3 | - | 1 | MAX8880EUT+ | MAXIM | MAX8880EUT+ | IC; VREG; ULTRA-LOW-IQ LOW-DROPOUT LINEAR REGULATOR WITH POK; SOT23-6 | |
| 45 | U4 | - | 1 | NC7WZ07P6X | FAIRCHILD SEMICONDUCTOR | NC7WZ07P6X | IC; BUF; TINY LOGIC ULTRA-HIGH SPEED DUAL BUFFER; SC70-6 | |
| 46 | PCB | - | 1 | MAX20345SYS | MAXIM | PCB | PCB:MAX20345SYS | - |
| 47 | MISC2-MISC4 | DNI | 3 | 3025010-03 | QUALTEK ELECTRONICS CORP | 3025010-03 | CONNECTOR; MALE; USB-A MINI-B; USB 4P(A)M - USB MINI 5P(B)M; STRAIGHT; 36IN | |
| TOTAL | | | 166 | | | | | |

MAX20345 EV Kit Schematics

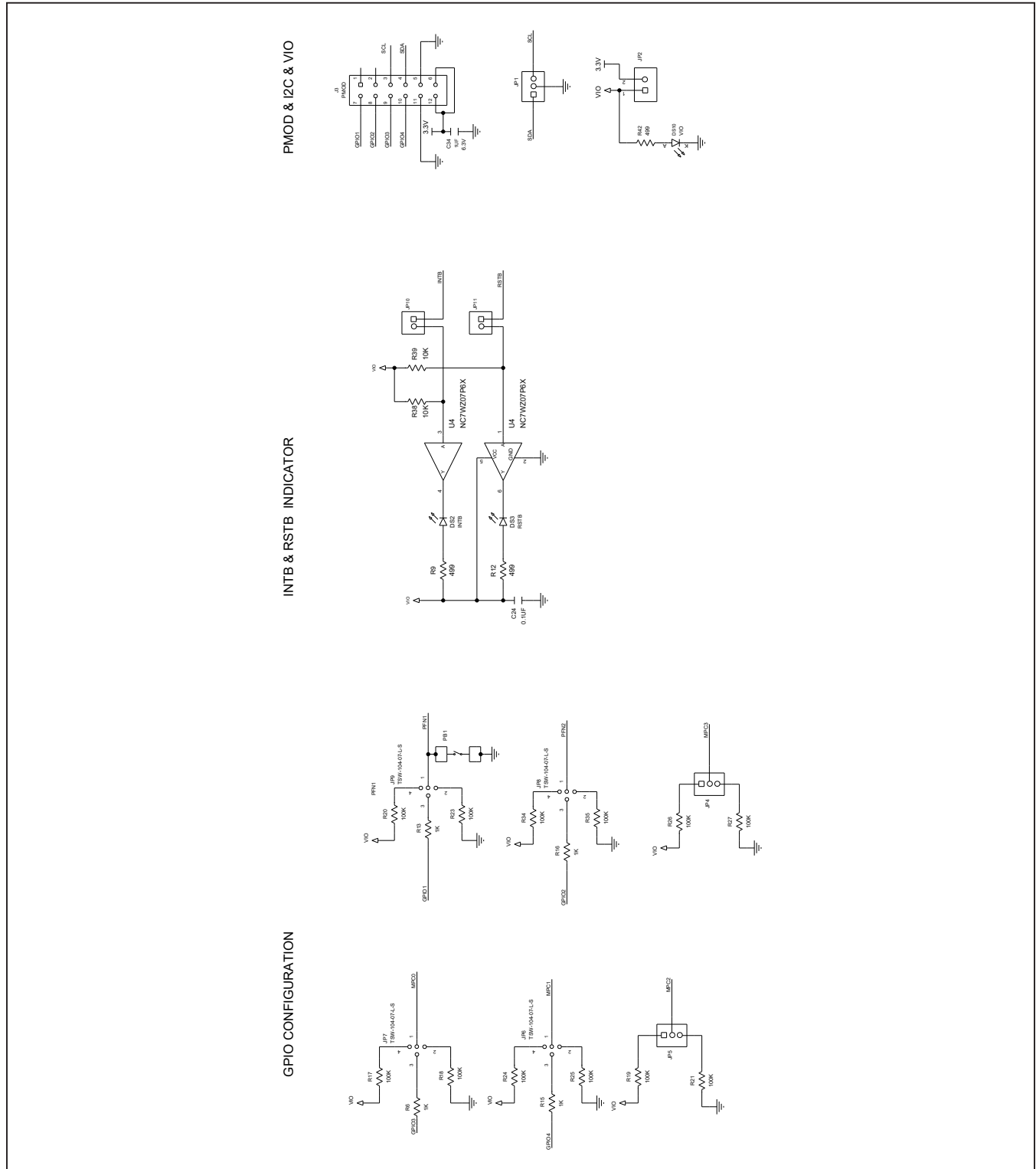

MAX20345 EV Kit Schematics (continued)

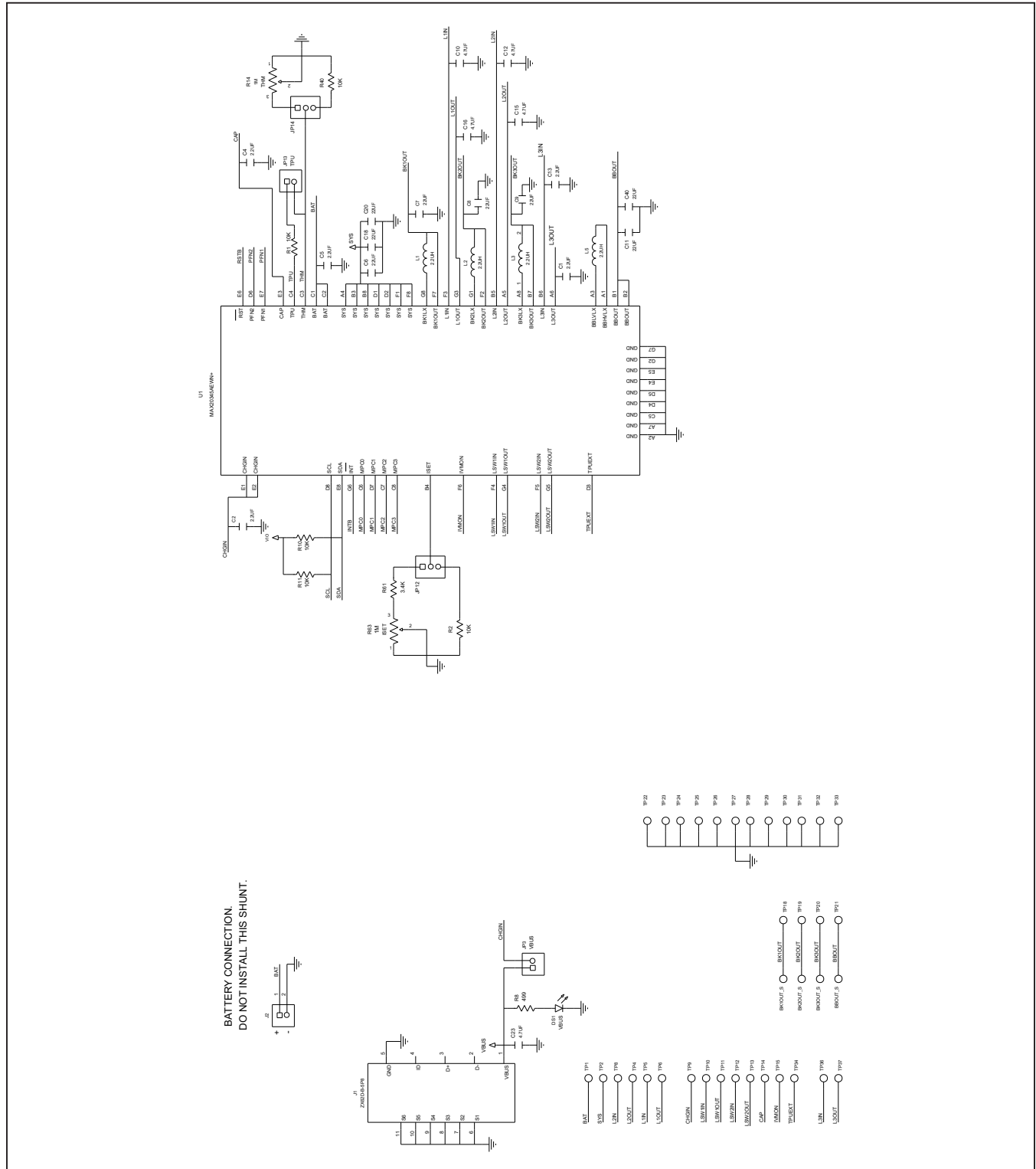

MAX20345 EV Kit PCB Layouts

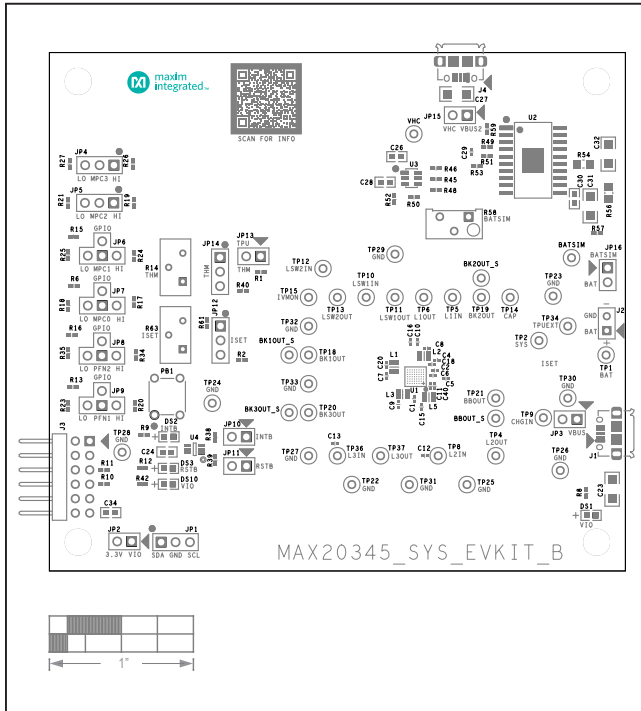

MAX20345 EV Kit PCB Layout—Silk Top

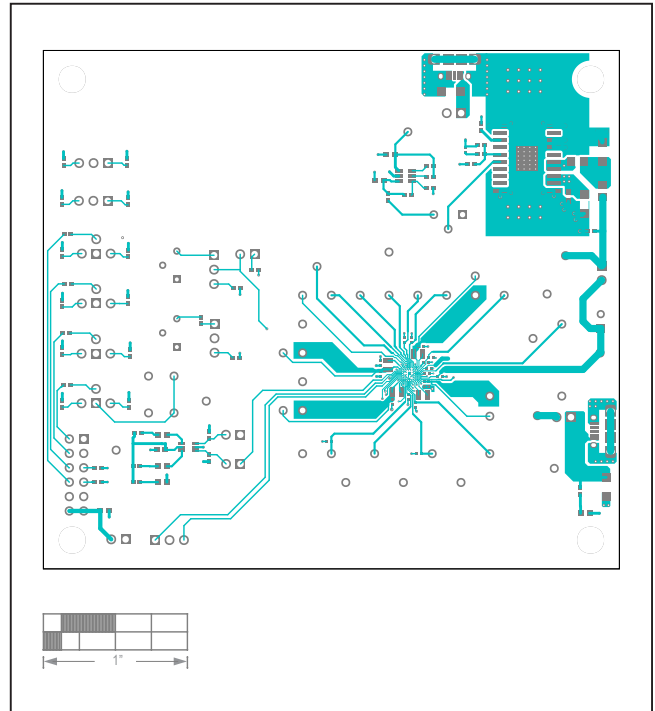

MAX20345 EV Kit PCB Layout—Top

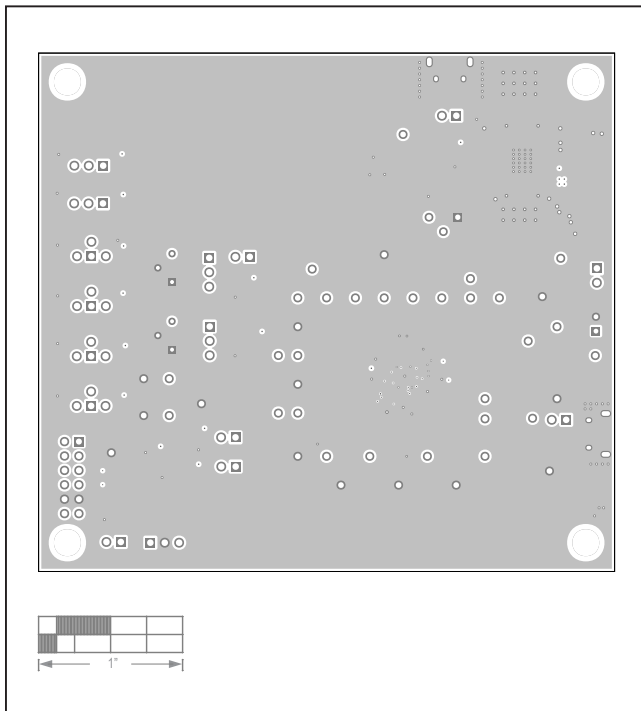

MAX20345 EV Kit PCB Layout—Layer 2

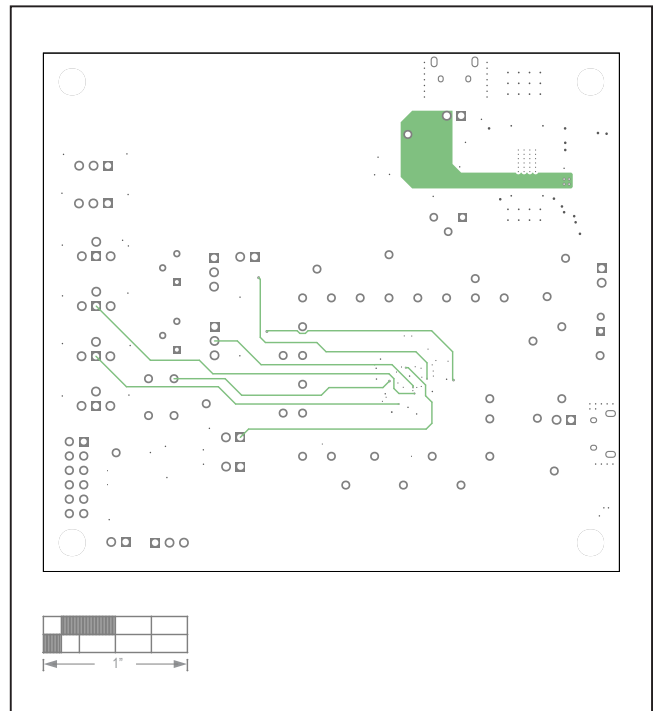

MAX20345 EV Kit PCB Layout—Layer 3

MAX20345 EV Kit PCB Layouts (continued)

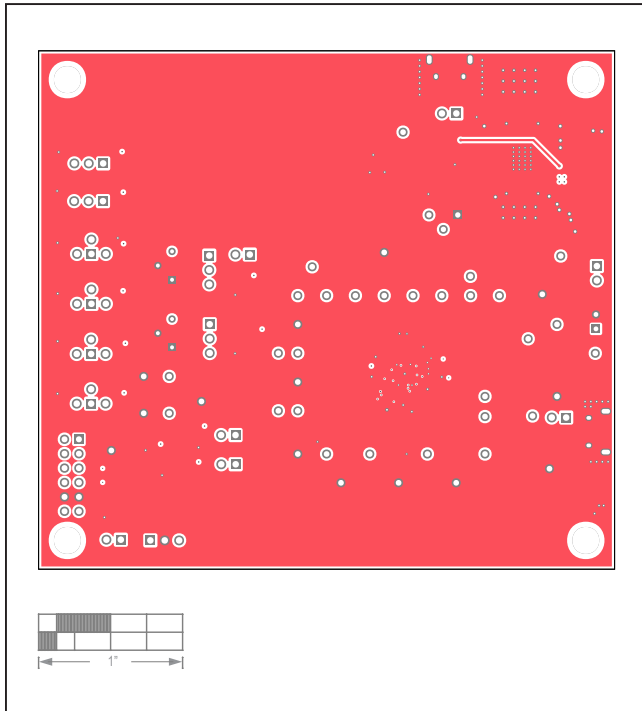

MAX20345 EV Kit PCB Layout—Layer 4

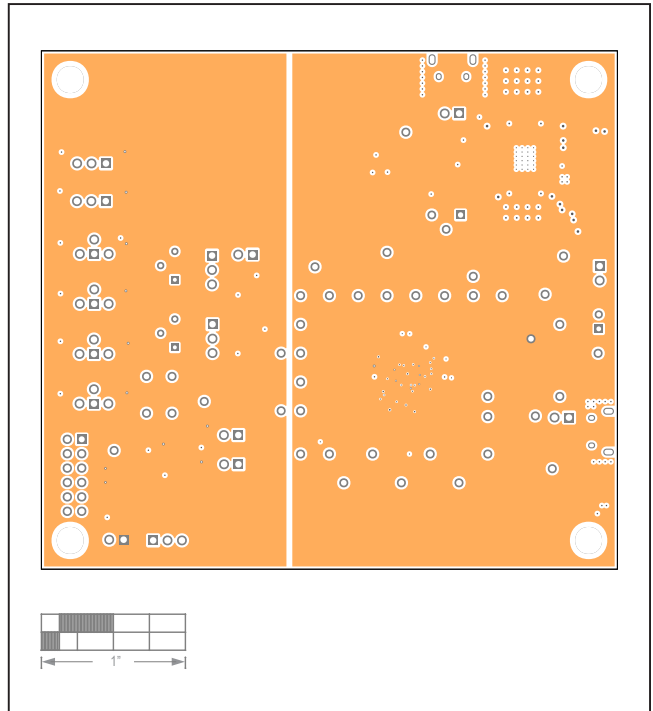

MAX20345 EV Kit PCB Layout—Layer 5

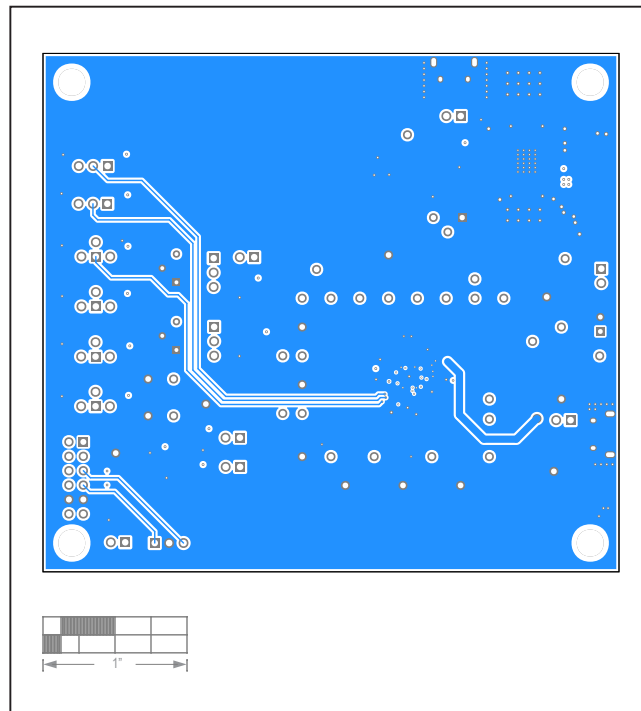

MAX20345 EV Kit PCB Layout—Bottom

Revision History

| REVISION NUMBER | REVISION DATE | DESCRIPTION | PAGES CHANGED |
|-----------------|---------------|--------------------------|---------------|
| 0 | 11/21 | Release for Market Intro | — |

