



Click [here](#) to ask an associate for production status of specific part numbers.

MAX25220, MAX25221, MAX25221B, MAX25221C

MAX25221 Evaluation Kit/ MAX25221 Evaluation System

General Description

The MAX25221 evaluation kit (EV kit) is a fully assembled and tested surface-mount PCB used to evaluate MAX25221 and MAX25221B automotive 4-Channel TFT-LCD Power Supply with VCOM Buffer or the MAX25220 automotive 4-Channel TFT-LCD Power Supply without VCOM. Each output rail (AVDD, NAVDD, VGON, VGOFF and VCOM) can be independently adjusted via I²C. The EV kit demonstrates the device's features: adjustable output voltage, fault protection, VCOM temperature compensation, and non-volatile memory programming. The EV kit exposes an I²C interface which can operate in conjunction with the MINIQUSB+ adapter or a third party I²C master like a general-purpose microcontroller. The EV kit also includes Windows®-compatible software that provides a simple graphical user interface (GUI) for exercising the features of the IC. The EV system includes both the EV kit and the MINIQUSB+ adapter board.

Benefits and Features

- 2.65V to 5.5V Input Range
- Default Output Voltages
 - 6.8V Output at 200mA (Boost Converter)
 - -6.8V Output at -200mA (Inverting Regulator)
 - 12V Output at 15mA (Positive-Charge Pump Regulator)
 - -10V Output at 15mA (Negative-Charge Pump Regulator)
 - -2.49V Output at 100mA (VCOM Buffer)
- The EV Kit Components Fit the 2.1MHz Frequency; for Using 420kHz, Hardware Changes Are Needed
- Spread Spectrum
- Dedicated GUI
- Full Sequencing Flexibility
- Proven PCB Layout
- Fully Assembled and Tested

MAX25221 EV Kit Files

FILE	DESCRIPTION
MAX25221GUISetupVxx.exe	Windows GUI Installer

Windows is a registered trademark and service mark of Microsoft Corporation.

Quick Start

Required Equipment

- MAX25221 EV kit
- 2.65 to 5.5V, 3A power supply
- Voltmeter
- MINIQUSB+ interface board with USB cable
- User-supplied Windows-compatible PC with a spare USB port

Note: In the following sections, software-related items are identified by bolding. Text in **bold** refers to items directly from the EV kit software. Text in **bold and underlined** refers to items from the Windows operating system.

Procedure

The EV kit is fully assembled and tested. To verify board operation, follow the steps:

Stand Alone

- Verify that shunts are installed across pins 1-2 on jumpers J1–J4 and J5 has no jumper installed.
- Connect the positive terminal of the power supply to the TFT_POWER_IN pad and the negative terminal to the GND1 PCB pad.
- Set the power supply TFT_POWER_IN at 5V.
- Turn on the power supply.
- Verify that the green LED (DS1) is on.
- Verify that the boost converter (AVDD PCB pad) is 6.8V.
- Verify that the inverting converter (NAVDD PCB pad) is -6.8V.
- Verify that the positive-gate voltage regulator (VGON PCB pad) is +12V.
- Verify that the negative-gate voltage regulator (VGOFF PCB pad) is -10V.
- Verify that the VCOM buffer (VCOM PCB pad) regulator is -2.49V. (Only for MAX25221, MAX25221B, MAX25221C)

Ordering Information appears at end of data sheet.

319-100548; Rev 2; 8/21

I²C Mode

- Visit www.maximintegrated.com/evkitsoftware download the latest version of the EV kit software, MAX25221GUISetupVxx.exe.
- Install the EV kit software (GUI) on your PC by running the MAX25221GUISetupVxx.exe program.
- The EV kit software application will be installed together with the required MINIUSB+ drivers.
- Verify that shunts are installed across pins 1-2 on jumpers J1-J3, J7, J9-J11, and J17.
- Verify that shunts are installed across pins 2-3 on jumpers J5 and J12.
- Connect the MINIUSB+ interface board's P3 header to the J14 header on the EV kit.
- Connect the positive terminal of the power supply to the TFT_POWER_IN pad and the negative terminal to the GND1 PCB pad.
- Set the power supply VIN at 5V.
- Turn on the power supply.
- Verify that the green LED (DS1) is on.
- Launch the EV kit software application.
- From the EV kit software toolbar, select **Device** → **Scan for Address**. Verify the ENABLE pin in the GUI is enabled. The GUI scans the I²C bus for available slave addresses on the bus and selects the first one (in this case, the MAX25221 I²C address with J5 settings: 42H). Press **OK** once the MAX25220/MAX25221/MAX25221B/MAX25221C I²C address has been found. [Figure 1](#), is a screen capture of MAX25221 Evaluation Kit Software (GUI).
- Verify that the status bar in the bottom-right corner of the GUI displays **EV Kit: Connected**.
- In the **GENERAL SETTINGS** group box press **START button**.
- In the **INDICATORS SEQ ON** and **FLT PIN** status should be green.
- All channels are turned on outputting AVDD 6.8V, NAVDD -6.8V, VGON 12V, VGOFF -10V, VCOM -2.49V.
- For more details on how to use the GUI and all the features available, click on the GUI **Help** menu item.

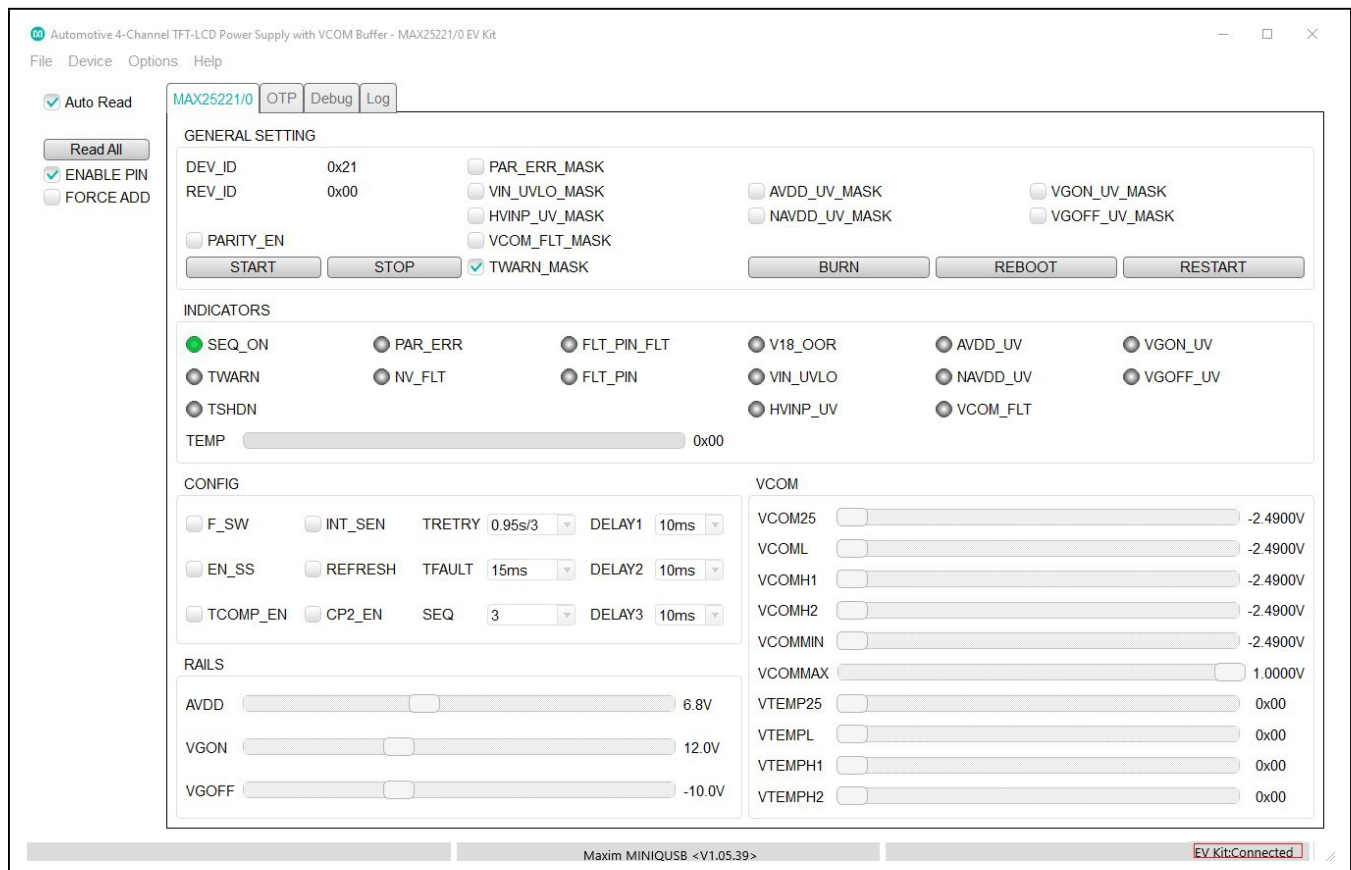

Figure 1. MAX25221 Evaluation Kit Software (GUI)

Detailed Description of Hardware

Jumper Setting

In the following tables, several jumper settings illustrate features of the MAX25221 EV kit.

Power LED Enable (J1)

A green LED (DS1) is used to indicate that the EV kit is powered on.

The LED can be disconnected from the power supply, allowing precise current-consumption evaluation (see [Table 1](#)).

Fault LED Enable (J2)

A red LED (DS2) is used to indicate a fault condition. The LED can be disconnected from the power supply, allowing precise current-consumption evaluation (see [Table 2](#)).

SCL Pull Up (J3)

See [Table 3](#) for jumper functions SCL Pull Up (J3).

Table 1. Jumper Functions (J1)

SHUNT POSITION	DS1 POWER LED
1-2*	Connected
Open	Disconnected

*Default position.

Table 2. Jumper Functions (J2)

SHUNT POSITION	DS2 FAULT LED
1-2*	Connected
Open	Disconnected

*Default position.

Table 3. Jumper Functions SCL Pull Up (J3)

SHUNT POSITION	SCL VOLTAGE PULL UP
1-2	On-board 1.5kΩ Pull up to DVDD
Open	External Pull up

*Default position.

Enable (J4)

The MAX25220/MAX25221/MAX25221B/MAX25221C IC can be disabled acting on the EN pin, reducing the current consumption to its minimum value. Furthermore, an external digital signal can be used to enable/disable the IC (see [Table 4](#) and [Table 6](#)).

ADD_SEL I²C Slave Address—Mode (J5)

The IC's 7-bit I²C slave address can be selected between two options through the J5 jumper setting (see [Table 5](#)). Additionally, the stand-alone mode can be selected with this jumper.

External ADD control (J6)

For future improvement.

Default condition Open.

External Enable (J7)

The MAX25220/MAX25221/MAX25221B/MAX25221C IC can be enabled or disabled acting GUI command **ENABLE_P** or external digital command (see [Table 6](#)).

Table 4. Jumper Functions Enable (J4)

SHUNT POSITION	MAX25220/MAX25221/MAX25221B/ MAX25221C
1-2*	Enable
Open**	External control from EN loop on board edge
2-3	Disable

*Default position.

** J7 must be open.

Table 5. Jumper Functions (J5)

SHUNT POSITION	MODE 7-BIT I ² C SLAVE ADDRESS
1-2	I ² C Mode: 0x52
2-3*	I ² C Mode: 0x42
Open	Stand Alone

*Default position.

For MAX25221B and MAX25221C only:

I²C Mode: 0x52 read only

I²C Mode: 0x42 read/write only

Table 6. Jumper Functions (J7)

SHUNT POSITION	MAX25220/MAX25221/MAX25221B/ MAX25221C
1-2*	Enabled from GUI Control [ENABLE_PIN]
Open	Externally controlled through digital signal (EN at board edge)

*Default position.

NVM Programming (J8, J13)

The EV kit is equipped with a low voltage boost regulator able to provide the VPROG voltage (8.5V) needed for NVM programmability. The VPROG is controlled by the GUI and enabled only during burning procedure. In order to use this feature, J13 jumper must be installed and J8 can be used to select the boost circuitry input voltage (see [Table 7](#) and [Table 8](#)).

FLT (J9)

Allows the Fault signal FLTB to be sent to GUI or an external device (see [Table 9](#)).

SCL (J10)

The SCL can be connected to MINIQUSB+ or external device (see [Table 10](#)).

Table 7. Jumper Functions (J8)

SHUNT POSITION	VPROG BOOST INPUT VOLTAGE
1-2	MINIQUSB+ 3.3V
2-3*	VIN

*Default position.

Table 8. Jumper Functions (J13)

SHUNT POSITION	VPROG BOOST OUTPUT VOLTAGE
1-2*	+8.5V power VPROG pin
Open	

*Default position.

Table 9. Jumper Functions (J9)

SHUNT POSITION	FLT SIGNAL
1-2*	MINIQUSB+ 3.3V
Open	External Signal (FLT at board edge)

*Default position.

Table 10. Jumper Functions (J10)

SHUNT POSITION	SCL SIGNAL
1-2*	MINIQUSB+ 3.3V
Open	External Signal

*Default position.

SDA (J11)

The SDA could be connected to GUI or external device (see [Table 11](#)).

Digital Domain Voltage (J12)

The EV kit exposes open-drain digital signals (FLT, SDA, and SCL) that are pulled up to what is referred as the “digital domain voltage.”

Digital domain voltage can be selected between the EV kit input voltage (VIN) and the fixed 3.3V provided by the MINIQUSB+. Alternatively, you can force an external voltage as digital reference (see [Table 12](#)).

SDA Pull Up (J17)

See [Table 13](#) for jumper functions SDA Pull Up (J17).

Table 11. Jumper Functions (J11)

SHUNT POSITION	SDA SIGNAL
1-2*	MINIQUSB+ 3.3V
Open	External Signal

*Default position.

Table 12. Jumper Functions (J12)

SHUNT POSITION	DIGITAL DOMAIN
1-2	MINIQUSB+ 3.3V
2-3*	VIN
Open	Externally provided (DVDD test point)

*Default position.

Table 13. Jumper Functions SDA Pull Up (J17)

SHUNT POSITION	SDA VOLTAGE PULL UP
1-2*	On-board 1.5kΩ Pull up to DVDD
open	External Pull up

*Default position.

MAX25221 Evaluation Kit/ MAX25221 Evaluation System

MAX25220, MAX25221,
MAX25221B, MAX25221C

VCOM (MAX25221/MAX25221B/MAX25221C Only)

The VCOM output voltage is programmed using I²C to a value between -2.49V and +1V with output peak currents between +/-120mA.

The VCOM output could operate in two different ways.

VCOM without Temperature Compensation (see [Table 14](#))

VCOM with Temperature Compensation

The VCOM output voltage can be compensated for temperature changes using an external or internal temperature sensors, see [Table 15](#), [Table 16](#), and [Table 17](#).

For details of how to use the VCOM temperature compensation function, refer to the sections *VCOM Temperature Compensation* and *VCOM Temperature Compensation Example* in the MAX25220/MAX25221/MAX25221B/MAX25221C data sheet.

Table 14. VCOM without Temperature Compensation Registers

REGISTER	DESCRIPTION	
TCOMP_EN	TCOMP_EN" bit in the DELAYVCOM_LSB Register [0X08 Bit 1]	[0] disables this functionality.
VCOM25	Sets the VCOM value between the range define from the registers VCOMMIN and VCOMMAX	
VCOMMIN	Define Minimum value of VCOM	
VCOMMAX	Define Maximum value of VCOM	

*Default position.

Table 15. VCOM Temperature Compensation Setting Registers

REGISTER	DESCRIPTION	
TCOMP_EN	TCOMP_EN" bit in the DELAYVCOM_LSB Register [0X08 Bit 1]	[1] Enable [0] Disable
INT_SEN	int_sensor bit in the CONFIG register [0X07 Bit 7] select the sensor	[0] Internal Sensor [1]* External T Sensor

*Default position.

Ordering Information

PART	TYPE
MAX25221EVKIT#	EV Kit
MAX25221EVSYS#	EV System

#Denotes RoHS compliant.

MAX25221EVKIT# and MAX25221EVSYS# are supplied in their standard configuration to evaluate MAX25221ATJ/V+.

To evaluate MAX25221B it also necessary to order MAX25221BATJ/V+.

To evaluate MAX25221C it also necessary to order MAX25221CATJ/V+.

VPROG

The EV kit includes a Boost converter in order to supply 8.5V 25mA for programming. To perform non-volatile programming this voltage should be connected to the VPROG pin.

Verify the Jumpers status See [Table 7](#) and [Table 8](#).

Using the GUI send a BURN command, the VPROG_EN connected to SHDN pin enables the Boost converter for a time of 20ms.

All values in registers 0x07 to 0x15 will be stored in non-volatile memory.

Table 16. VTEMP Registers

REGISTER	DESCRIPTION
VTEMPL	Voltage at TEMP* pin corresponding to low-temperature breakpoint in VCOM compensation curve.
VTEMP25	Voltage at TEMP* pin at 25°C
VTEMP_H1	Voltage at TEMP pin corresponding to first high-temperature breakpoint in VCOM compensation curve.
VTEMP_H2	Voltage at TEMP pin corresponding to second high-temperature breakpoint in VCOM compensation curve.

Table 17. VCOM Registers

REGISTER	DESCRIPTION
VCOM_L	Delta VCOM at the temperature corresponding to VTEMP_L. This value sets the difference between the VCOM value at 25°C and that at VTEMP_L.
VCOM25	Set the VCOM value at 25°C
VCOM_H1	Delta VCOM at VTEMP_H1. This value sets the difference between the VCOM value at 25°C and that at VTEMP_H1.
VCOM_H2	Delta VCOM at VTEMP_H2. This value sets the difference between the VCOM value at VTEMP_H1 and that at VTEMP_H2.

MAX25221 Evaluation Kit/ MAX25221 Evaluation System

MAX25220, MAX25221, MAX25221B, MAX25221C

MAX25221 Frequency Switch (FSW) 2.1MHz EV Kit Bill of Materials

The table below refers only to MAX25221/MAX25221B/MAX25221C FSW 2.1MHz. For MAX25221 FSW 420kHz and MAX25220 see the dedicated tables to follow.

DESIGNATION	DNI/DNP	QTY	MFG PART #	MANUFACTURER	DESCRIPTION
C1-C3, C7, C19, C37, C38, C40	-	8	CL10B106MQ8NRN	SAMSUNG ELECTRONICS	10UF; 20%; 6.3V; X7R; CERAMIC CAPACITOR 0603
C4, C10, C11, C13, C21, C23, C39	-	7	GRM188R71E105KA12	MURATA	1UF; 10%; 25V; X7R; CERAMIC CAPACITOR 0603
			CGA3E1X7R1E105K	TDK	
C5, C9, C12, C22, C31, C52	-	6	CC0603KRX7R0BB104	YAGEO	0.1UF; 10%; 100V; X7R; CERAMIC CAPACITOR 0603
			GRM188R72A104KA35	MURATA	
C6, C8, C34, C36	-	4	GRM188R72A223KAC4	MURATA	22000PF; 10%; 100V; X7R; CERAMIC CAPACITOR 0603
			C0603C223K1RAC	KEMET	
C14, C24-C26	-	4	C0603C104K8RAC	KEMET	0.1UF; 10%; 10V; X7R; CERAMIC CAPACITOR 0603
			C0603C103K5RAC	KEMET	
C18	-	1	GRM188R71H103K	MURATA	0.01uF; 10%; 50V; X7R; CERAMIC CAPACITOR 0603
			C1210C106M3RAC	KEMET	
C27, C29	-	2	GRM32DR71E106M	MURATA	10UF; 20%; 25V; X7R; CERAMIC CAPACITOR 1210
			GRM188R61H225KE11	MURATA	
C30	-	1	GRM188R61H225KE11	MURATA	2.2UF; 10%; 50V; X5R; CERAMIC CAPACITOR 0603
C33, C35	-	2	CL10A105KB8NNN	SAMSUNG	1UF; 10%; 50V; X5R; CERAMIC CAPACITOR 0603
			GRM188R61H105KAAL	MURATA	
C47	-	1	C0603C100K1GAC	KEMET	10PF; 10%; 100V; COG; CERAMIC CAPACITOR 0603
C50, C51	-	2	GCM31CR71A226KE02	MURATA	22UF; 10%; 10V; X7R; CERAMIC CAPACITOR 1206
D3	-	1	NRVTS245ESFT1G	ON SEMICONDUCTOR	DIODE; V=45V; IF=2.0A; SOD-123FL
D4-D6	-	3	BAT54S	FAIRCHILD SEMICONDUCTOR	DIODE; IV=30V; IF=0.2A; SOT-23
D7	-	1	CMDSH05-4	CENTRAL SEMICONDUCTOR CORP	DIODE; V=40V; IF=0.5A; SOD-323
DS1	-	1	LTST-C170GKT	LITE-ON ELECTRONICS INC	DIODE LED; V=2.1V; IF=0.01A; 0805
DS2, DS3	-	2	LTST-C170EKT	LITE-ON ELECTRONICS INC	DIODE LED; V=2.0V; IF=0.02A; 0805
J1-J3, J6, J7, J9-J11, J13, J17	-	10	PBC02SAAN	SULLINS ELECTRONICS CORP.	CONNECTOR; 2PINS; STRAIGHT THROUGH HOLE; MALE
J4, J5, J8, J12	-	4	PEC03SAAN	SULLINS ELECTRONICS CORP.	CONNECTOR; 3PINS; STRAIGHT THROUGH HOLE; MALE
J14	-	1	803-87-020-20-001101	PRECI-DIP SA	CONNECTOR; 20PINS; DOUBLE ROW RIGHT ANGLE SOLDER TAIL ;FEMALE
J15	-	1	61301021121	WURTH ELECTRONICS INC	CONNECTOR; 10PINS; DUAL PIN HEADER STRAIGHT THROUGH HOLE; MALE
J16	-	1	DF11-6DP-2DSA(24)	HIROSE ELECTRIC CO LTD	CONNECTOR; STRAIGHT DOUBLE-ROW THROUGH HOLE; MALE
L1	-	1	ETQ-P3M1R0YFN	PANASONIC	1UH; 20%; 10.7A; COMPOSITE SMT
L2	-	1	LQH32CN220K23	MURATA	22UH; +/-10%; 0.25A; SHIELDED SMT
L3, L4	-	2	74437324022	WURTH ELECTRONICS INC	2.2UH; 20%; 3.25A; SHIELDED SMT
Q1	-	1	BCP5516TA	DIODES INCORPORATED	TRANSISTOR; I=1A; V=60V; PD=2W; SOT-223
Q2	-	1	IRLML6346	INTERNATIONAL RECTIFIER	TRANSISTOR; I=2.5A; V=30V; PD=1.3W ;SOT-23
Q3	-	1	BSS84	FAIRCHILD SEMICONDUCTOR	MOSFET P-CHANNEL; ID=-0.13A; VDSS=-50V; PD=0.36W;SOT-23
R1, R2, R26	-	3	CR0603-FX-1001ELF	BOURNS	1K OHM; 100PPM; 0.10W; RESISTOR 0603
R3	-	1	CRCW06033K40FK	VISHAY DALE	3.4K OHM; 100PPM; 0.10W; RESISTOR 0603
R4, R6	-	2	CRCW06031K50FK	VISHAY DALE	1.5K; 100PPM; 0.10W; RESISTOR 0603
R5	-	1	CHPHT0603K1002FGT	VISHAY SFERNICE	10K OHM; 100PPM; 0.0125W; RESISTOR 0603
R7	-	1	CRCW0603330R0FK	VISHAY DALE	330 OHM; 100PPM; 0.10W; RESISTOR 0603
R8, R14	-	2	RC1608J000CS	SAMSUNG ELECTRONICS	0 OHM ;5%; 0.10W; JUMPER 0603
R10	-	1	ERJ-3GEYJ242	PANASONIC	2.4K OHM; 200PPM; 0.10W; RESISTOR 0603
R12	-	1	CRCW06031K00FK	VISHAY DALE	1K; 100PPM; 0.10W; RESISTOR 0603
R19	-	1	ANY	ANY	0 OHM; JUMPER; 0.10W; RESISTOR 0603
R21, R22	-	2	CRCW0603100KFK	VISHAY DALE	100K; 100PPM; 0.10W; RESISTOR 0603
R23	-	1	CRCW0603510KFK	VISHAY DALE	510K; 100PPM; 0.10W; RESISTOR 0603
R24	-	1	CRCW060386K6FK	VISHAY DALE	86.6K OHM; 100PPM; 0.10W; RESISTOR 0603
R25	-	1	CRCW060310K0FK	VISHAY DALE	10K; 100PPM; 0.10W; RESISTOR 0603
RT1	-	1	NCU18XH103F6S	MURATA	10K; TO=+/-1%; THERMISTOR; 0603
U1	-	1	MAX25221ATJ/V+	MAXIM	AUTOMOTIVE 4-CHANNEL TFT-LCD POWER SUPPLY WITH VCOM
U2	-	1	MAX8571EUT+	MAXIM	HIGH-EFFICIENCY LCD BOOST WITH TRUE SHUTDOWN
C15, C16, C48, C49	DNP	0	C0603YC101KAT2A	AVX	100PF; 10%; 16V; X7R; CERAMIC CAPACITOR 0603
			C0603C103K5RAC	KEMET	
C17	DNP	0	GRM188R71H103K	MURATA	0.01uF; 10%; 50V; X7R; CERAMIC CAPACITOR 0603
			GRM188R71E105KA12;	MURATA	
C20, C41, C42	DNP	0	CGA3E1X7R1E105K;	TDK	1UF; 10%; 25V; X7R; CERAMIC CAPACITOR 0603
			GRM188R61H225KE11	MURATA	
C28	DNP	0	CC0603KRX7R0BB104	YAGEO	0.1UF; 10%; 100V; X7R; CERAMIC CAPACITOR 0603
			GRM188R72A104KA35	MURATA	
C32	DNP	0	C1210C106M3RAC	KEMET	10UF; 20%; 25V; X7R; CERAMIC CAPACITOR 1210
			GRM32DR71E106M	MURATA	
C43-C46	DNP	0	RC1608J000CS	SAMSUNG ELECTRONICS;	0 OHM ;5%; 0.10W; JUMPER 0603
			CRCW060310R0FK	VISHAY DALE	
R9, R11, R18	DNP	0	RC1608J000CS	SAMSUNG ELECTRONICS;	0 OHM ;5%; 0.10W; JUMPER 0603
R15, R16, R27, R28	DNP	0	CRCW060310R0FK	VISHAY DALE	0 OHM ;1%; 0.10W; JUMPER 0603
R17	DNP	0	CHPHT0603K1002FGT	VISHAY SFERNICE	10K ;100PPM; 0.0125W; RESISTOR 0603
R20	DNP	0	ANY	ANY	0 OHM ;5%; 0.10W; JUMPER 0603

Note: DNI—DO NOT INSTALL (PACKOUT); DNP—DO NOT PROCURE.

MAX25221 Evaluation Kit/ MAX25221 Evaluation System

MAX25220, MAX25221,
MAX25221B, MAX25221C

MAX25221 Frequency Switch 420kHz EV Kit Bill of Materials

The table below refers to the changes needed for the MAX25221, MAX25221B, MAX25221C FSW 420kHz.

DESIGNATION	DNI/DNP	QTY	MFG PART #	MANUFACTURER	DESCRIPTION
C6, C8, C34, C36		4	GRM188R72A104KA35D	MURATA	10000 PF; 10%; 50V; X7R; CERAMIC CAPACITOR 0603
C43-C44		2	C1210C106M3RAC	KEMET	10UF; 20%; 25V; X7R; CERAMIC CAPACITOR 1210
			GRM32DR71E106M	MURATA	
L3, L4		2	74437346100	WURTH ELECTRONICS INC	INDUCTOR; SHIELDED; 10UH; 20%;3.25A

Note: DNI—DO NOT INSTALL (PACKOUT); DNP—DO NOT PROCURE.

MAX25220 EV Kit Bill of Materials

For the MAX25220 EV kit refer to the MAX25221 EV kit Bill of Materials and make the necessary changes from the table below.

DESIGNATION	DNI/DNP	QTY	MFG PART #	MANUFACTURER	DESCRIPTION
C18	DNI	1	C0603C103K5RAC	KEMET	0.01uF; 10%; 50V; X7R; CERAMIC CAPACITOR 0603
			GRM188R71H103K	MURATA	
C21	DNI	1	GRM188R71E105KA12	MURATA	1UF; 10%; 25V; X7R; CERAMIC CAPACITOR 0603
			CGA3E1X7R1E105K	TDK	
C52	DNI	1	CC0603KRX7R0BB104	YAGEO	0.1UF; 10%; 100V; X7R; CERAMIC CAPACITOR 0603
			GRM188R72A104KA35	MURATA	
Q1	DNI	1	BCP5516TA	DIODES INCORPORATED	TRANSISTOR; I=1A; V=60V; PD=2W; SOT-223
R7	DNI	1	CRCW0603330RFB	VISHAY DALE	330 OHM; 100PPM; 0.10W; RESISTOR 0603
R8, R14	DNI	2	RC1608J000CS	SAMSUNG ELECTRONICS	0 OHM ;5%; 0.10W; JUMPER 0603
R10	DNI	1	ERJ-3GEYJ242	PANASONIC	2.4K OHM; 200PPM; 0.10W; RESISTOR 0603
R12	DNI	1	CRCW06031K00FK	VISHAY DALE	1K; 100PPM; 0.10W; RESISTOR 0603
RT1	DNI	1	NCU18XH103F6S	MURATA	10K; TOL=+-1%; THERMISTOR; 0603
U1	-	1	MAX25220ATJ/V+	MAXIM	AUTOMOTIVE 4-CHANNEL TFT-LCD POWER SUPPLY WITHOUT VCOM

Note: DNI—DO NOT INSTALL (PACKOUT); DNP—DO NOT PROCURE.

MAX25221 EV Kit Schematic

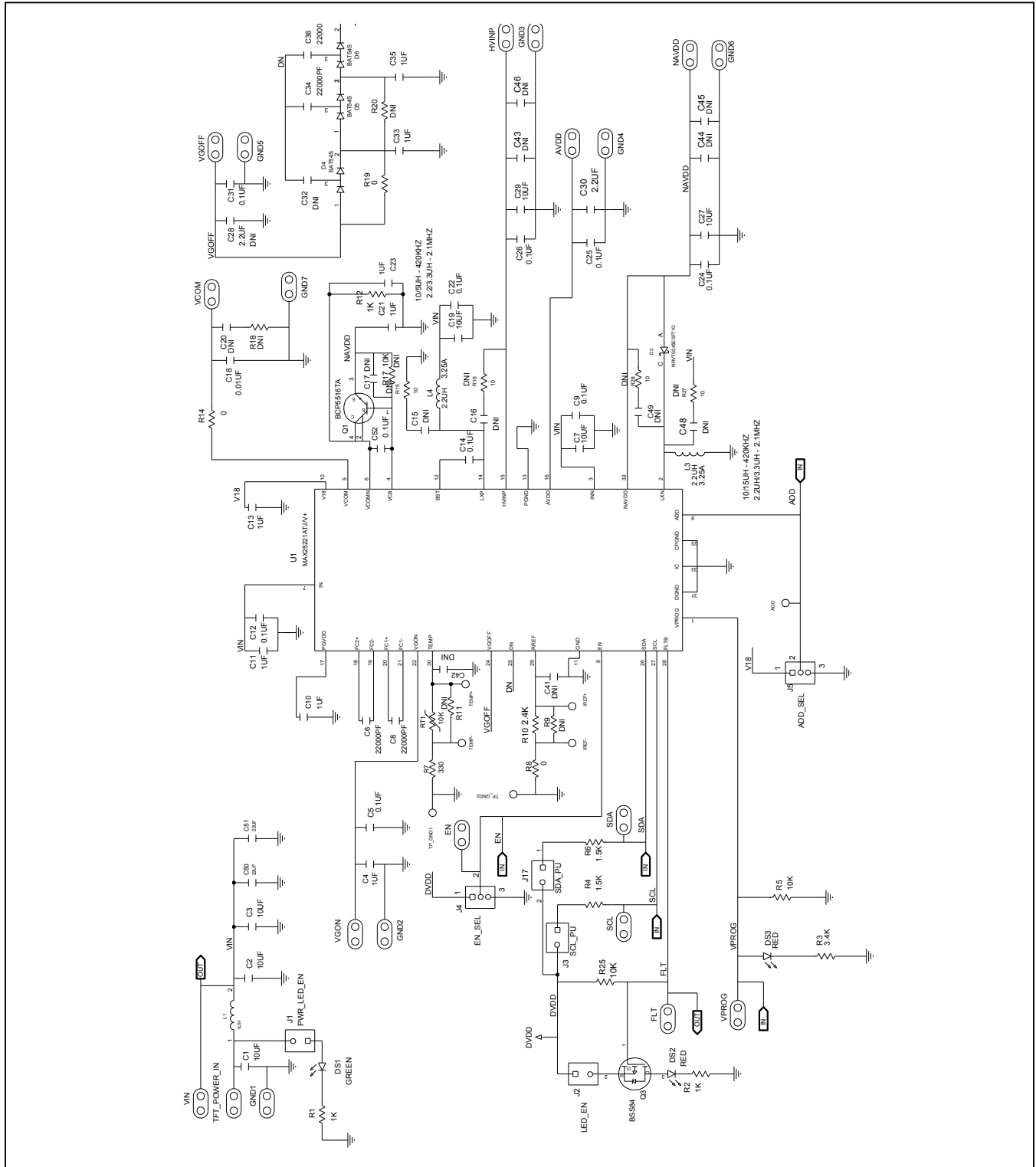

Figure 2. MAX25221 EV Kit Schematic 1-2

MAX25221 EV Kit Schematic (continued)

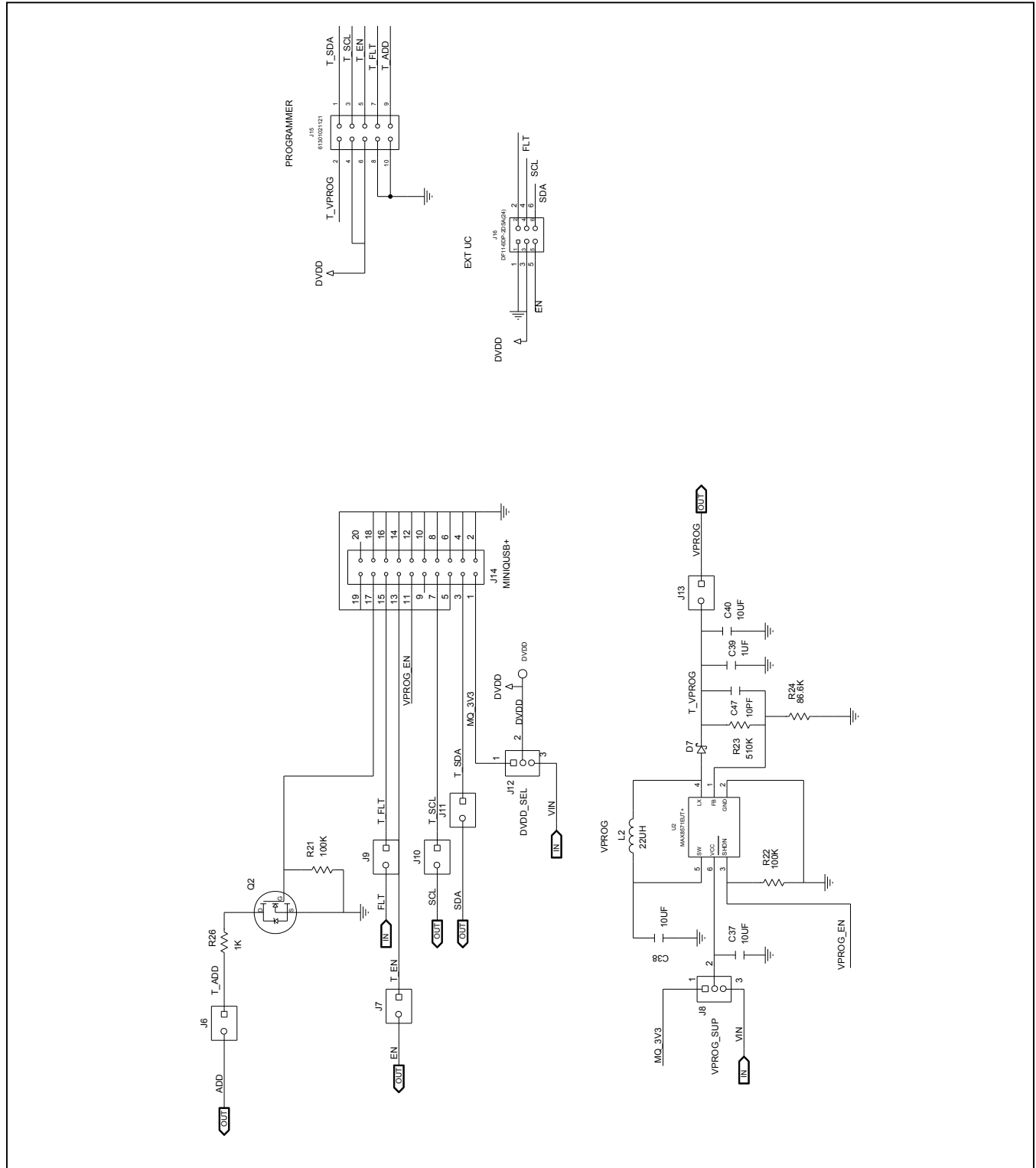
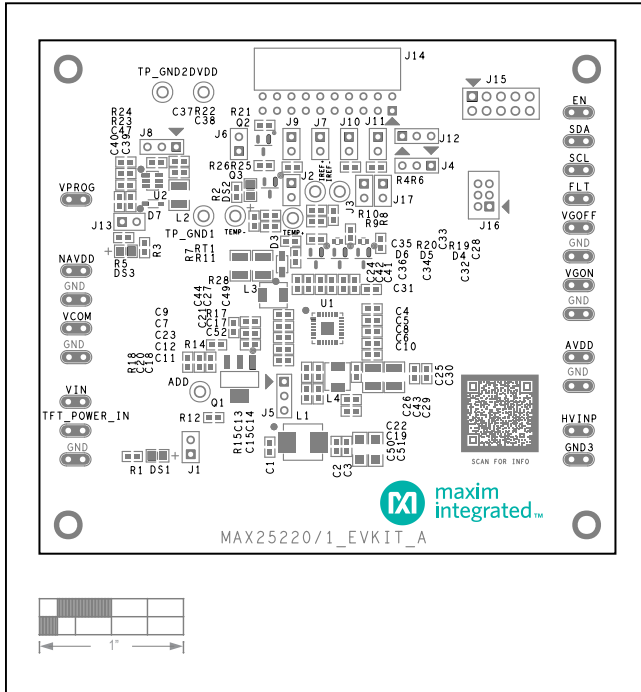

Figure 3. MAX25221 EV Kit Schematic 2-2

MAX25221 Evaluation Kit/ MAX25221 Evaluation System

MAX25220, MAX25221,
MAX25221B, MAX25221C

MAX25221 EV Kit PCB Layouts



MAX25221 EV Kit Component Placement Guide—Top Silkscreen

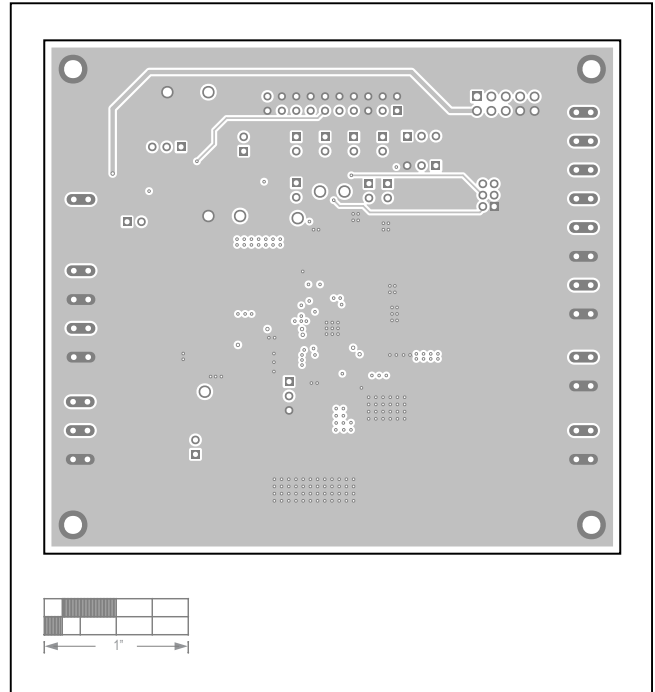

MAX25221 EV Kit PCB Layout—Internal Layer2

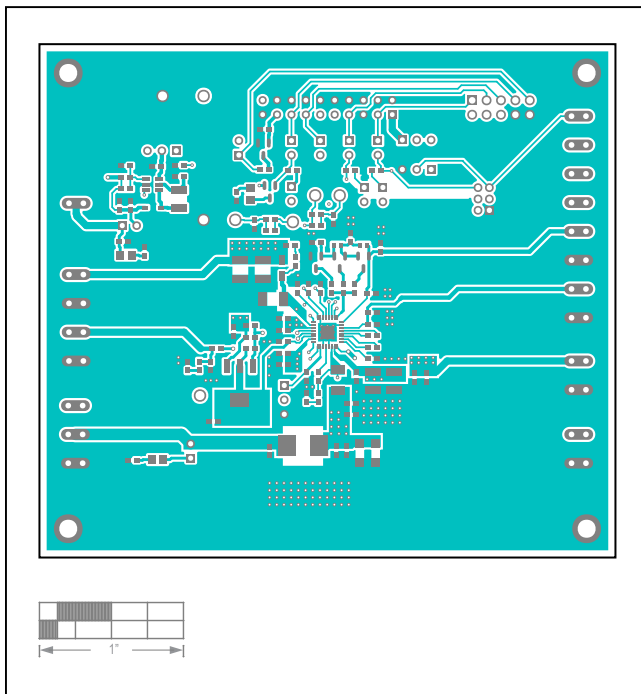

MAX25221 EV Kit PCB Layout—Top Layer+

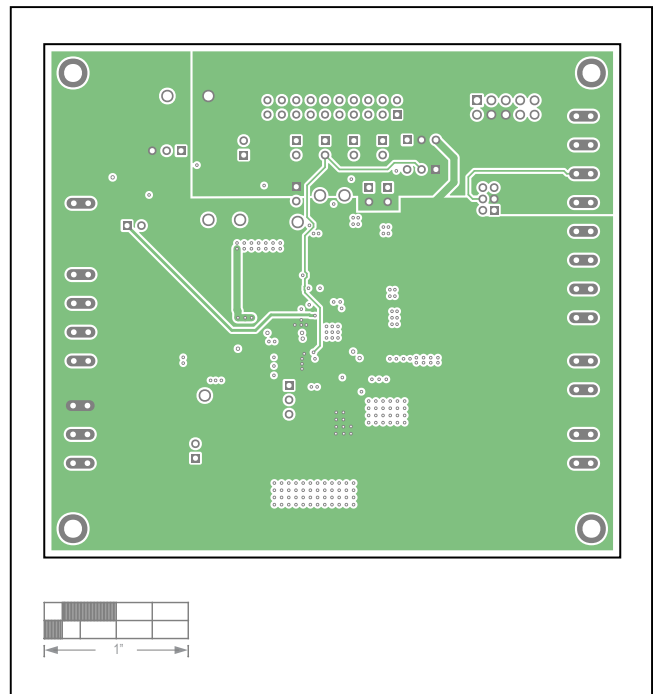

MAX25221 EV Kit PCB Layout—Internal Layer3

MAX25221 EV Kit PCB Layouts (continued)

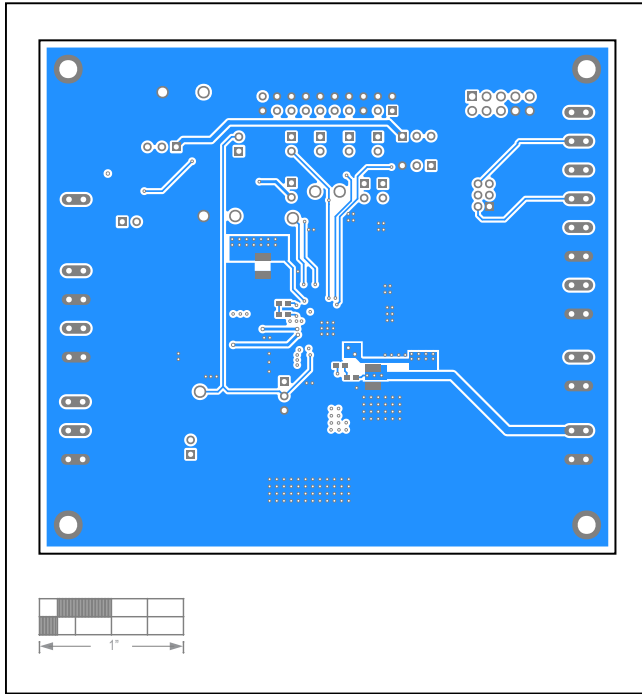

MAX25221 EV Kit PCB Layout—Bottom Layer

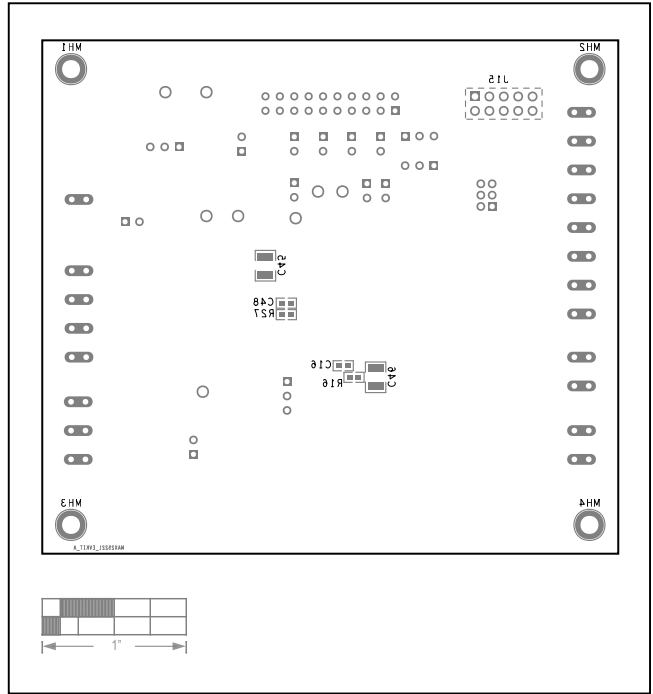

MAX25221 EV Kit PCB Layout—Bottom Components

Revision History

REVISION NUMBER	REVISION DATE	DESCRIPTION	PAGES CHANGED
0	6/20	Initial release	—
1	12/20	Updated part number, <i>General Description, Benefits and Features, Stand Alone, I²C Mode, Enable (J4), External Enable (J7), Table 4, Table 5, Table 6, VCOM (MAX25221 Only), Ordering Information, MAX25221 Frequency Switch 420kHz EV Kit Bill of Materials, MAX25220 EV Kit Bill of Materials</i>	1–14
2	8/21	Updated title, <i>Quick Start, Detailed Description of Hardware, Ordering Information, Bill of Materials</i>	1–3, 5–9



Information furnished by Analog Devices is believed to be accurate and reliable. However, no responsibility is assumed by Analog Devices for its use, nor for any infringements of patents or other rights of third parties that may result from its use. Specifications subject to change without notice. No license is granted by implication or otherwise under any patent or patent rights of Analog Devices. Trademarks and registered trademarks are the property of their respective owners.