

## Evaluates: MAX25302A/MAX25302B

## MAX25302 Evaluation Kit

### General Description

The MAX25302 evaluation kit (EV kit) evaluates the MAX25302A/MAX25302B IC family of low-noise linear regulators. The EV kit operates over an input range of 1.7V to 5.5V, provides any output voltage range from 0.6V to 5.3V, and delivers up to 2A of current. The EV kit comes with the MAX25302AATD/V+ installed.

### Features

- Evaluates the MAX25302A/MAX25302B IC in a 10-pin (3mm x 3mm) TDFN
- 1.7V to 5.5V Input Range
- 0.6V to 5.3V Resistor-Configurable Output Voltage (MAX25302B, with IC Replacement)
- 1.2V to 5.0V Jumper-Configurable Output Voltage (MAX25302A, On Board with Output Set to 3.3V)
- Up to 2A Output Current
- Proven 2-Layer 1oz Copper PCB Layout
- Demonstrates Compact Solution Size
- Fully Assembled and Tested

[Ordering Information](#) appears at end of data sheet.

### Quick Start

#### Required Equipment

- MAX25302 EV kit
- 5.5V, 2A DC power supply
- Electronic load capable of 2A
- Digital voltmeter (DVM)

#### Procedure

The EV kit is fully assembled and tested. To verify board operation, follow the steps:

**Caution: Do not turn on the power supply until all connections are completed.**

- 1) Verify that jumpers JU101, SELA, and SELB are in their default positions, as shown in Tables 1, 2, and 3.
- 2) Connect the 5.5V power supply between the IN and nearest GND terminal posts.
- 3) Connect the 2A electronic load between the OUT and nearest GND terminal posts.
- 4) Connect the DVM between the OUT and nearest GND terminal posts.
- 5) Turn on the power supply.
- 6) Enable the electronic load.
- 7) Verify that the voltage at the OUT terminal post is approximately 3.3V.

### MAX25302 EV Kit Files

FILE	DESCRIPTION
MAX25302 EV Kit BOM	EV Kit Bill of Materials
MAX25302 EV Kit PCB Layout	EV Kit Layout
MAX25302 EV Kit Schematic	EV Kit Schematic

## Detailed Description of Hardware

The MAX25302 EV kit evaluates the MAX25302A/MAX25302B IC family. The MAX25302A/MAX25302B are low noise linear regulators that deliver 2A of output current with only 5.1 $\mu$ V<sub>RMS</sub> of output noise from 10Hz to 100kHz. These regulators require only 100mV of input-to-output headroom at full load.

The MAX25302 EV kit operates over an input range of 1.7V to 5.5V. The EV kit includes an installed MAX25302AATD/V+. The output is jumper configurable between 1.2V and 5.0V (Table 4) and can deliver 2A of current.

### EN for the MAX25302A/MAX25302B

The EV kit provides a jumper JU101 to enable or disable the MAX25302A (or the MAX25302B after IC replacement). See Table 1 for jumper setting of jumper JU101.

### GS for the MAX25302B

When evaluating the MAX25302B, the Ground Sense (GS) pin must be connected to ground to stabilize the output with load. The EV kit provides a jumper SELA to connect the MAX25302B GS pin to ground. See Table 2 for jumper setting of jumper SELA.

### POK for the MAX25302B

The EV kit provides a test point to access the POK output signal from the MAX25302B. Remove shunt from jumper SELB to access the MAX25302B POK test point. See Table 3 for jumper setting of jumper SELB.

### Evaluating the MAX25302B

The EV kit can evaluate the MAX25302B after IC (U1) replacement. When evaluating the MAX25302B, modify the EV kit with the following steps:

- 1) Replace U1 with the MAX25302BATD/V+.
- 2) Install feedback resistors R101 and R102 to obtain the desired output voltage between 0.6V and 5.3V. Refer to the MAX25302 IC data sheet for feedback resistor calculations.

## Output Selection (SELA and SELB) for the MAX25302A

The EV kit provides a set of jumpers SELA and SELB to configure the output voltage of the MAX25302A. See Table 4 for jumper setting of jumpers SELA and SELB.

**Table 1. EN on MAX25302A/MAX25302B (JU101)**

JU101 SHUNT POSITION	DESCRIPTION
1-2*	Enabled. EN = IN
2-3	Disabled. EN = GND

\*Default position.

**Table 2. GS on MAX25302B (SELA)**

SELA SHUNT POSITION	DESCRIPTION
1-2	Not allowed (for MAX25302A output selection)
2-3*	GS = GND

\*Default position.

**Table 3. POK on MAX25302B (SELB)**

SELA SHUNT POSITION	DESCRIPTION
1-2	Not allowed (for MAX25302A output selection)
2-3	Not allowed (for MAX25302A output selection)
Not Installed*	Access signal at the POK test point

\*Default position.

Table 4. SELA and SELB on MAX25302A (SELA, SELB)

SELA		SELB		OUTPUT VOLTAGE
SHUNT POSITION	SELA CONNECTION	SHUNT POSITION	SELB CONNECTION	
Not Installed	Hi-Z	1-2	IN	1.2
1-2	IN	Not Installed	Hi-Z	1.5
Not Installed	Hi-Z	2-3	GND	1.8
Not Installed	Hi-Z	Not Installed	Hi-Z	2.5
2-3	GND	2-3	GND	3.0
2-3	GND	1-2	IN	3.1
2-3	GND	Not Installed	Hi-Z	3.3
1-2	IN	2-3	GND	4.0
1-2*	IN	1-2*	IN	5.0

\*Default position.

## Component Suppliers

SUPPLIER	WEBSITE
Murata/TOKO	<a href="http://www.murata.com">www.murata.com</a>
TDK	<a href="http://www.tdk.com">www.tdk.com</a>
Samsung Electro-Mechanics America, Inc.	<a href="http://www.samsungsem.com">www.samsungsem.com</a>

**Note:** Indicate that you are using the MAX25302A/MAX25302B when contacting these component suppliers.

## Ordering Information

PART	TYPE
MAX25302EVKIT#	EV Kit

#Denotes RoHS compliance.

MAX25302 EV Kit Bill of Materials

ITEM	REF_DES	DNI/DNP	QTY	MFG PART #	MANUFACTURER	VALUE	DESCRIPTION
1	C101	—	1	C0603C473K5RAC; GRM188R71H473KA61; GCM188R71H473KA55; CGA3E2X7R1H473K080AA	KEMET;MURATA; MURATA;TDK	0.047µF	CAPACITOR; SMT (0603); CERAMIC CHIP; 0.047µF; 50V; TOL = 10%; MODEL = X7R; TG = -55°C TO +125°C; TC = X7R
2	C102, C103	—	2	GRM31CR70J226K; GCM31CR70J226KE23	MURATA;MURATA	22µF	CAPACITOR; SMT (1206); CERAMIC CHIP; 22µF; 6.3V; TOL = 10%; MODEL = GRM SERIES; TG = -55°C TO +125°C; TC = X7R
3	GND, IN, OUT	—	3	108-0740-001	EMERSON NETWORK POWER	108-0740-001	CONNECTOR; MALE; PANELMOUNT; BANANA JACK; STRAIGHT; 1PIN
4	JU101, SELA, SELB	—	3	PEC03SAAN	SULLINS	PEC03SAAN	CONNECTOR; MALE; THROUGH HOLE; BREAKAWAY; STRAIGHT; 3PINS
5	R3	—	1	RC1608J000CS; CR0603-J-000ELF; RC0603JR-070RL	SAMSUNG ELECTRONICS; BOURNS;YAGEO PH	0	RESISTOR; 0603; 0Ω; 5%; JUMPER; 0.10W; THICK FILM
6	SU1-SU3	—	3	STC02SYAN	SULLINS ELECTRONICS CORP.	STC02SYAN	TEST POINT; JUMPER; STR; TOTAL LENGTH = 0.256IN; BLACK; INSULATION = PBT CONTACT = PHOSPHOR BRONZE; COPPER PLATED TIN OVERALL;
7	U1	—	1	MAX25302AATD/V+	MAXIM	MAX25302BATD/V+	EVKIT PART-IC; MAX25302BATD/V+; 2A AUTOMOTIVE LOW NOISE LDO LINEAR REGULATORS; PACKAGE OUTLINE DRAWING: 21-100420; LAND PATTERN DRAWING: 90-100149
8	PCB	—	1	MAX25302	MAXIM	PCB	PCB:MAX25302
9	GND_PAD, IN_PAD, OUT_PAD	DNP	0	9020 BUSS	WEICO WIRE	MAXIMPAD	EVK KIT PARTS; MAXIM PAD; WIRE; NATURAL; SOLID; WEICO WIRE; SOFT DRAWN BUS TYPE-S; 20AWG
10	C104	DNP	0	N/A	N/A	OPEN	PACKAGE OUTLINE 0603 NON-POLAR CAPACITOR
11	R1, R2, R4, R5	DNP	0	N/A	N/A	OPEN	RESISTOR; 0603; OPEN; FORMFACTOR
12	R105	DNP	0	N/A	N/A	SHORT	PACKAGE OUTLINE 0603 RESISTOR
<b>TOTAL</b>			<b>15</b>				

MAX25302 EV Kit Schematic Diagram

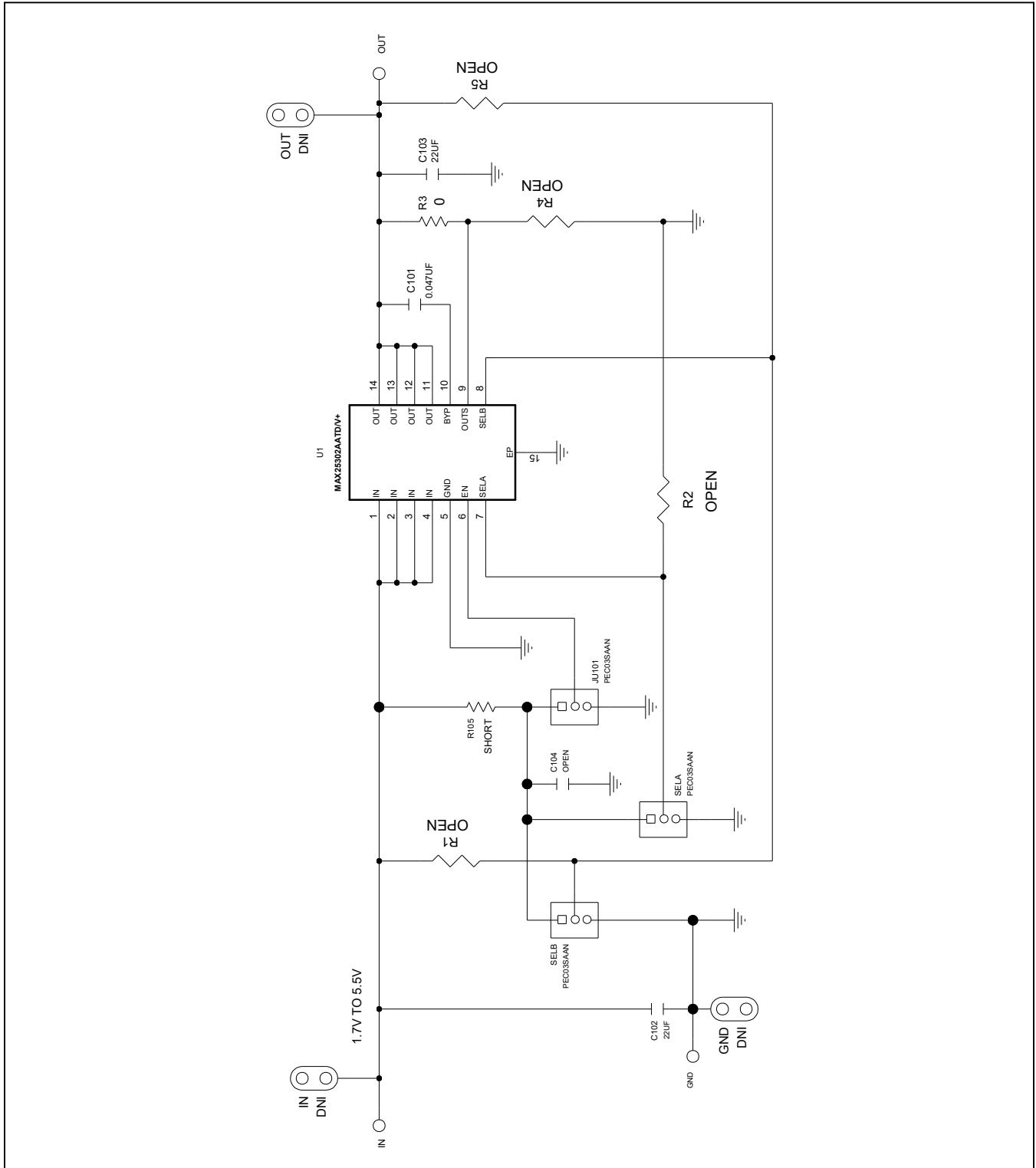

MAX25302 EV Kit PCB Layout Diagrams

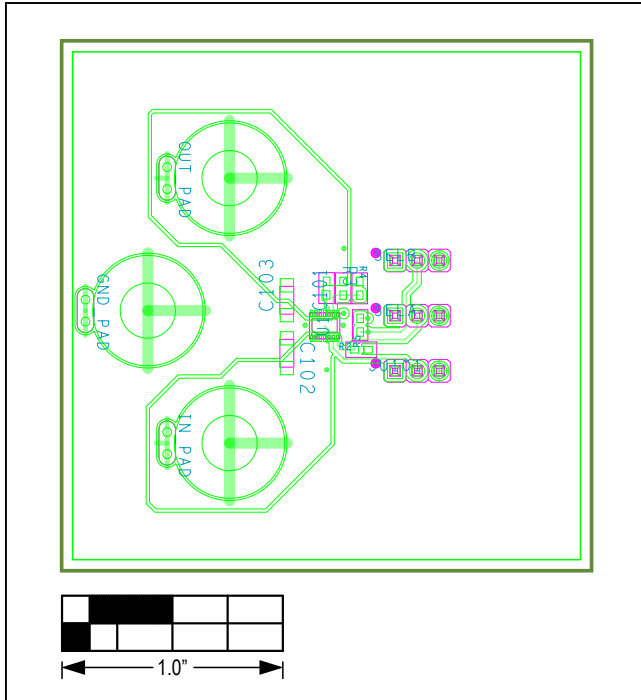

MAX25302 EV Kit—Top Silkscreen

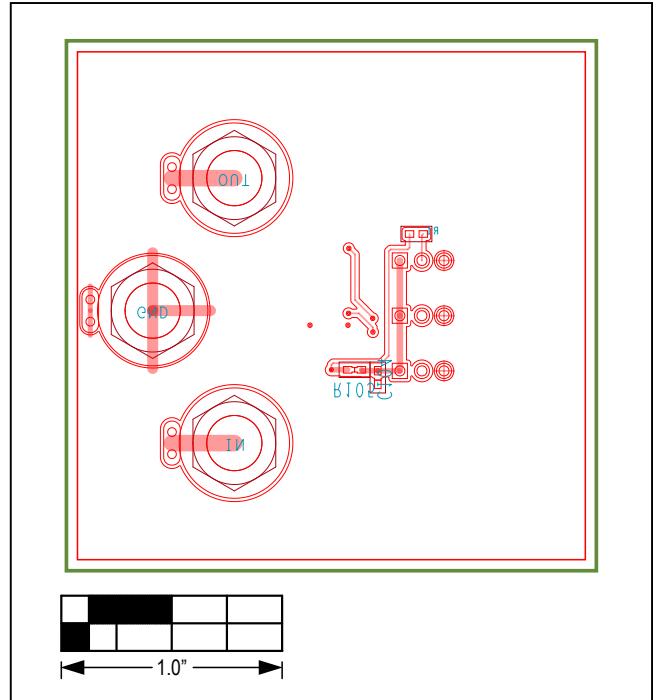

MAX25302 EV Kit—Top View

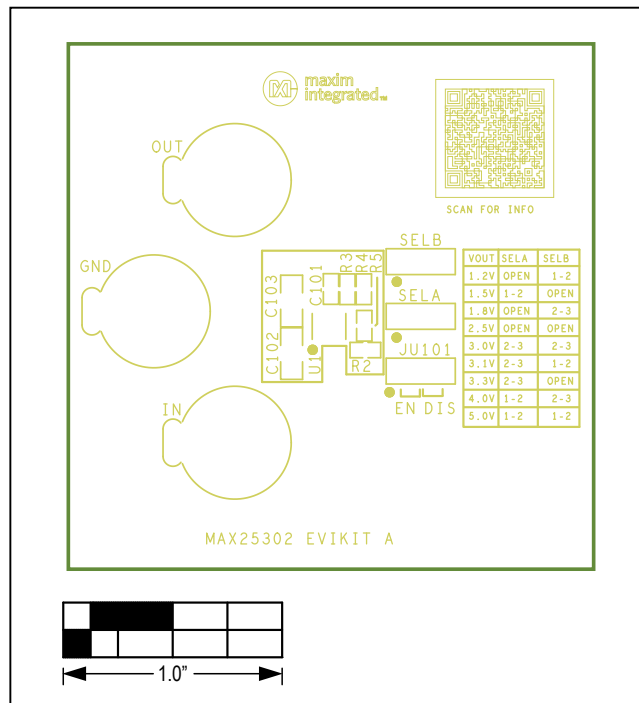

MAX25302 EV Kit—Bottom View

**Revision History**

<b>REVISION NUMBER</b>	<b>REVISION DATE</b>	<b>DESCRIPTION</b>	<b>PAGES CHANGED</b>
0	4/21	Initial release	—



Information furnished by Analog Devices is believed to be accurate and reliable. However, no responsibility is assumed by Analog Devices for its use, nor for any infringements of patents or other rights of third parties that may result from its use. Specifications subject to change without notice. No license is granted by implication or otherwise under any patent or patent rights of Analog Devices. Trademarks and registered trademarks are the property of their respective owners.