

General Description

The MAX31180 evaluation kit (EV kit) is a fully assembled and tested PCB to evaluate the MAX31180 spread-spectrum crystal multiplier. The EV kit operates from a single 3.3V supply and the onboard crystal provides a 25MHz clock signal. The EV kit also provides header pins to configure the clock frequency multiplier, the magnitude of the spread spectrum, and a means to disable the spread spectrum feature. An SMA connector for the clock output is included to easily facilitate the connection of test equipment.

EV Kit Contents

- Assembled circuit board, including MAX31180AUA+

Features

- Easy Evaluation of the MAX31180AUA+
- +3.3V Single-Supply Operation
 - Low Peak Cycle to Cycle 75ns Jitter Typical
 - Configurable Clock Multiplier
 - Selectable Spread Spectrum Magnitude
- Proven PCB Layout
- Fully Assembled and Tested

Ordering Information appears at end of data sheet.

MAX31180 EV Kit Board Photo

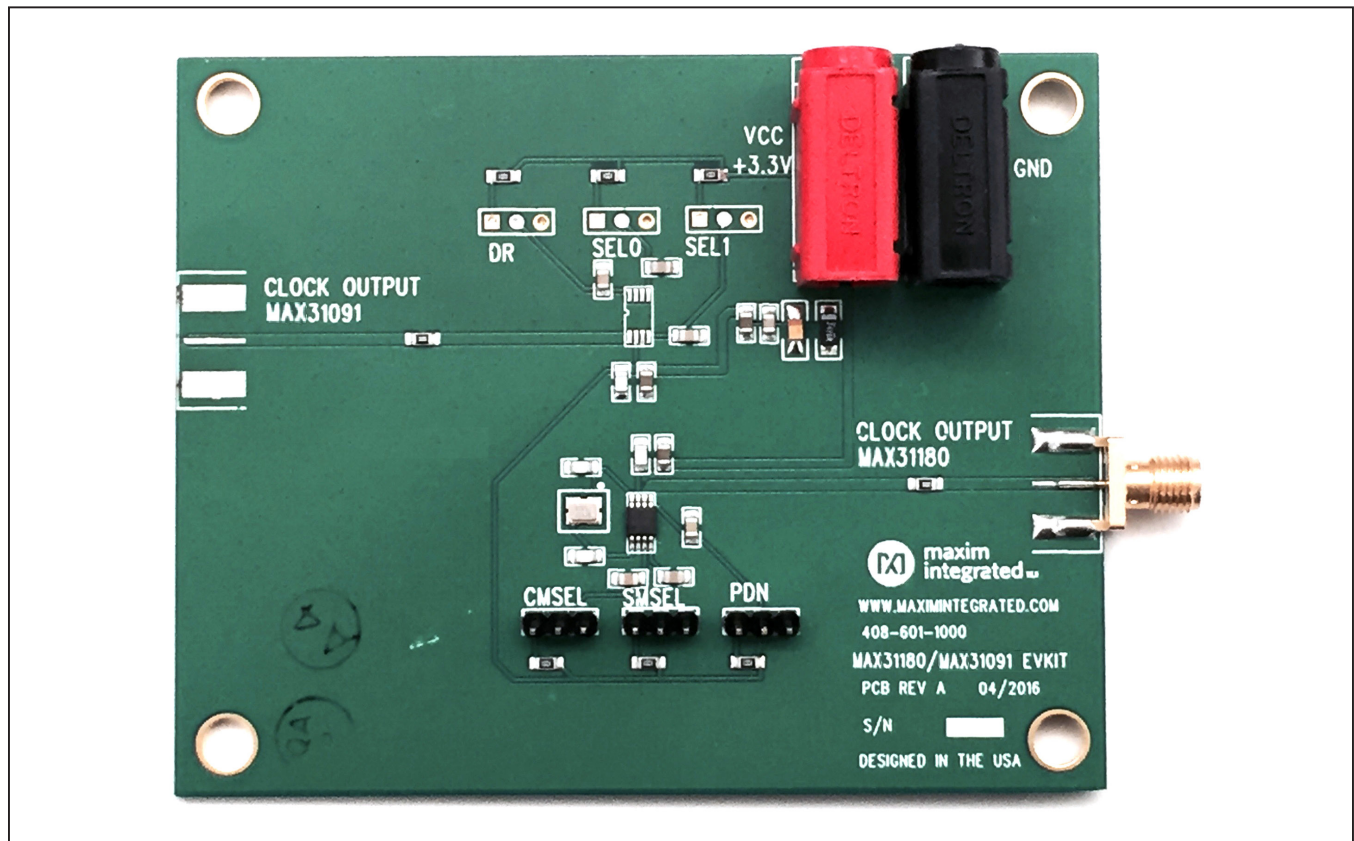

Quick Start

Required Equipment and Accessories

- One DC Power Supply capable of supplying +3.3V
- One multimeter for measuring the current
- One spectrum analyzer
- One SMA cable
- MAX31180 EV kit

Procedure

The EV Kit is fully assembled and tested. Follow the steps below to verify board operation:

Note: To configure the PDN, SMSEL, and CMSEL 3-pin headers, set the jumper to the right side of the header for “0” position and left side for the “1” position.

- 1) Place the EV kit on a nonconductive surface to ensure that nothing on the PCB is shorted to the workspace.
- 2) With the output set to +3.3V and disabled, connect the positive terminal of the DC supply through a Mutimeter to the red ($V_{CC}/+3.3V$) and negative terminal to black (GND) banana jacks of the MAX31180 EV kit.
- 3) Connect an SMA Cable to the MAX31180 CLOCK OUTPUT SMA Connector of the MAX31180 EV kit and connect the other end of the cable to the spectrum analyzer.
- 4) Set the jumper on PDN on the position connected to GND (0). This position of the PDN set the device to the Power-Down mode.
- 5) Set the jumper on CMSEL on the position connected to GND (0). This position of the CMSEL set the Device Output to the 1 x CLOCK mode (25MHz).
- 6) Set the center frequency of the spectrum analyzer to 25MHz (1 x CLOCK), reference level to 20dBm, and span = 10MHz.
- 7) Turn on the power supply. The supply current should be about 0mA and no signal present on the spectrum analyzer.

- 8) Remove the jumper from PDN and leave it open. This position of the PDN sets the device to the Power-Up mode and disables the spread spectrum. The spectrum analyzer shows a CW tone signal at 25MHz.
- 9) Set the jumper on PDN on the position connected to V_{CC} (1). This position of the PDN enables the Spread Spectrum.
- 10) Set the jumper on SMSEL on the position connected to GND (0). This position of the SMSEL set the device to the $\pm 0.5\%$ Spread Spectrum mode. The spectrum analyzer shows a spread spectrum centered at 25MHz and about 250KHz bandwidth ($\pm 0.5\%$).
- 11) By setting the SMSEL and CMSEL at the positions showed on [Table 1](#), you can also see the spread spectrums at 50MHz (2 x CLOCK) and 100MHz (4 x CLOCK), each with $\pm 1.0\%$ and $\pm 1.5\%$.

Detailed Description

The MAX31180 is a spread-spectrum clock generator with low jitter, selectable clock multiplier, selectable dither magnitude, and capable of accepting a 16MHz to 33.4MHz crystal connected to the X1 and X2 pins. In this EV kit, the mounted 25MHz crystal can be replaced and alternately, an external 16MHz to 33.4MHz clock can be applied to X1 in place of the crystal. In this setup, X2 would be left open. Using the CMSEL input, the user selects whether the crystal or clock input is multiplied by 1, 2, or 4. The MAX31180 is capable of generating spread-spectrum clocks from 16MHz to 134MHz.

The PLL can dither the output clock about its center frequency at a user-selectable magnitude. Using the SMSEL input, the user selects the dither magnitude. The PDN input can be used to place the device into a low-power standby mode where the SSO output is three-stated. If the PDN pin is open, the SSO output is active but the spread-spectrum dithering is disabled. The spread-spectrum dither rate is fixed at $f_{IN}/992$ to keep the dither rate above the audio frequency range. On power-up, the output clock (SSO) remains three-stated until the PLL reaches a stable frequency (f_{SSO}) and dither (f_{DITHER}).

Table 1. PDN, SMSEL, and CMSEL Configuration

NAME	FUNCTION
PDN	Active-Low Power-Down/Spread-Spectrum Disable. Tri-level digital input. 0 = Power-Down/SSO Three-States Open = Power-Up/Spread Spectrum Disabled 1 = Power-Up/Spread Spectrum Enabled
SMSEL	Spread-Spectrum Magnitude Select. Tri-level digital input. 0 = $\pm 0.5\%$ Open = $\pm 1.0\%$ 1 = $\pm 1.5\%$
CMSEL	Clock Multiplier Select. Tri-level digital input. 0 = 1x Open = 2x 1 = 4x

Note: Setting the jumper to the right side of the 3-pin header configures the function to "0" position and setting the jumper to the left side configure the function to "1" position.

Component Suppliers

SUPPLIER	WEBSITE
EPSON	www.eea.epson.com
AVX	www.avx.com
Murata	www.murata.com
TDK	www.tdk.com
Del-Tron	www.deltron.com

Note: Indicate that you are using the MAX31180 when contacting these component suppliers.

MAX31180 EV Bill of Materials

ITEM	QTY	REFERENCE	MANUFACTURER	PART NUMBER	DESCRIPTION	VALUE	PCB DECAL
1	1	C1	AVX	TAJA476K006RNJ	Tantalum cap 10%	47uF	1206
2	1	C6	AVX	TAJR106M006RNJ	Tantalum cap 10%	10uF	0805
3	3	C3, C13, C15	Murata	GRM21BR71E104KA01L	Ceramic cap 10%	100nF	0805
4	2	C9-10	Murata	GRM21A5C2E100JW01D	Ceramic cap 5%	10pF	0805
5	4	C11-12, C14, C16	Murata	GRM216R71H102KA01D	Ceramic cap 10%	1nF	0805
6	3	C2, C4-5	Murata	GCM21BR71E105KA56L	Ceramic cap 10%	1uF	0805
7	2	C7-8	Murata	GRM2165C1H221JA01D	Ceramic cap 5%	220pF	0805
8	2	R2-3	TDK		Resistor	0Ω	RES0805
9	6	R1, R4-6, R15, R17	TDK		Resistor	1kΩ	RES0805
10	1	JU1	Deltron	571-0500	Banana Jack Red		
11	1	JU2	Deltron	571-0100	Banana Jack Black		JACK
12	3	TP1-TP2, TP5	Digikey	609-3461-ND	3 pin Header		SIP\3P
13	3	TP3, TP6-TP7	DNP				
14	1	J1 (CLOCK OUTPUT) MAX31180	Cinch Conn	142-0701-801	SMA, Edge mount		SMA\EDGE
15	1	J2 (CLOCK OUTPUT) MAX31091	DNP				
16	1	U1 (MAX31091)	DNP				
17	1	U2 (MAX31180)	Maxim	MAX31180AUA+	IC		8UMAX
18	1	Y1 (FA-238)	Epson	FA-238 25.0000MB-K3	EPSON,25MHz,10pF/50ohm	CRYSTAL	3.2 x 2.5

MAX31180 EV Kit Schematic

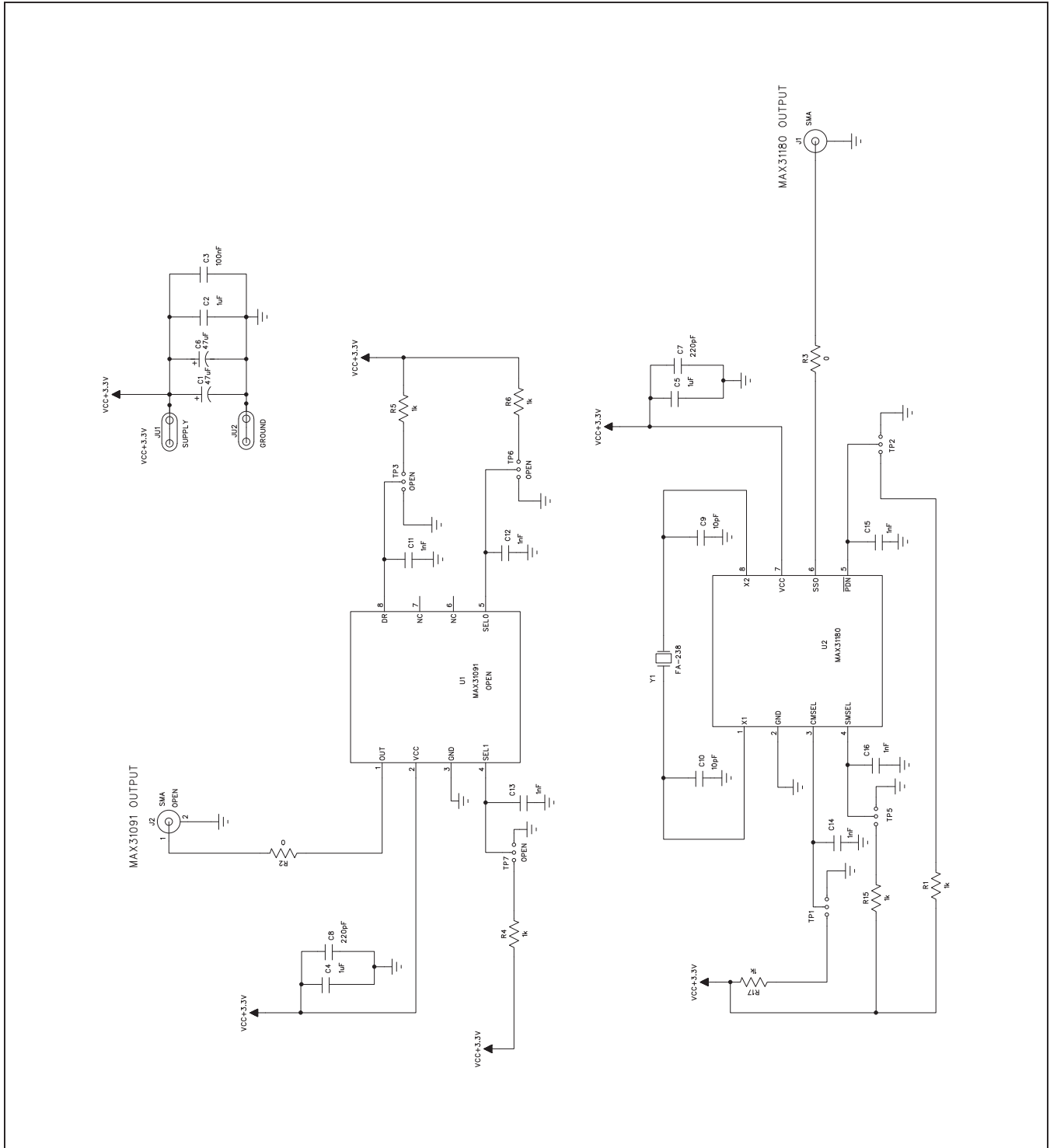

MAX31180 EV Kit PCB Layout Diagrams

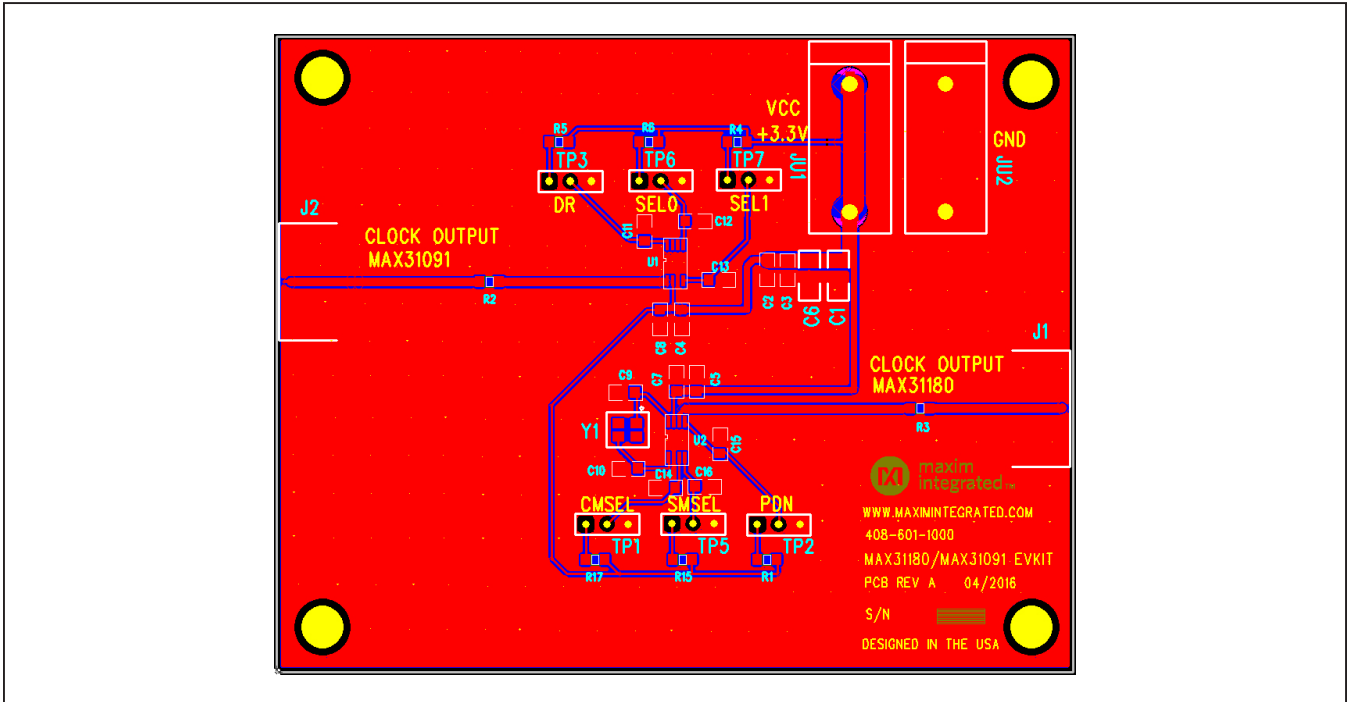

MAX31180 EV Kit—PCB Top Layer

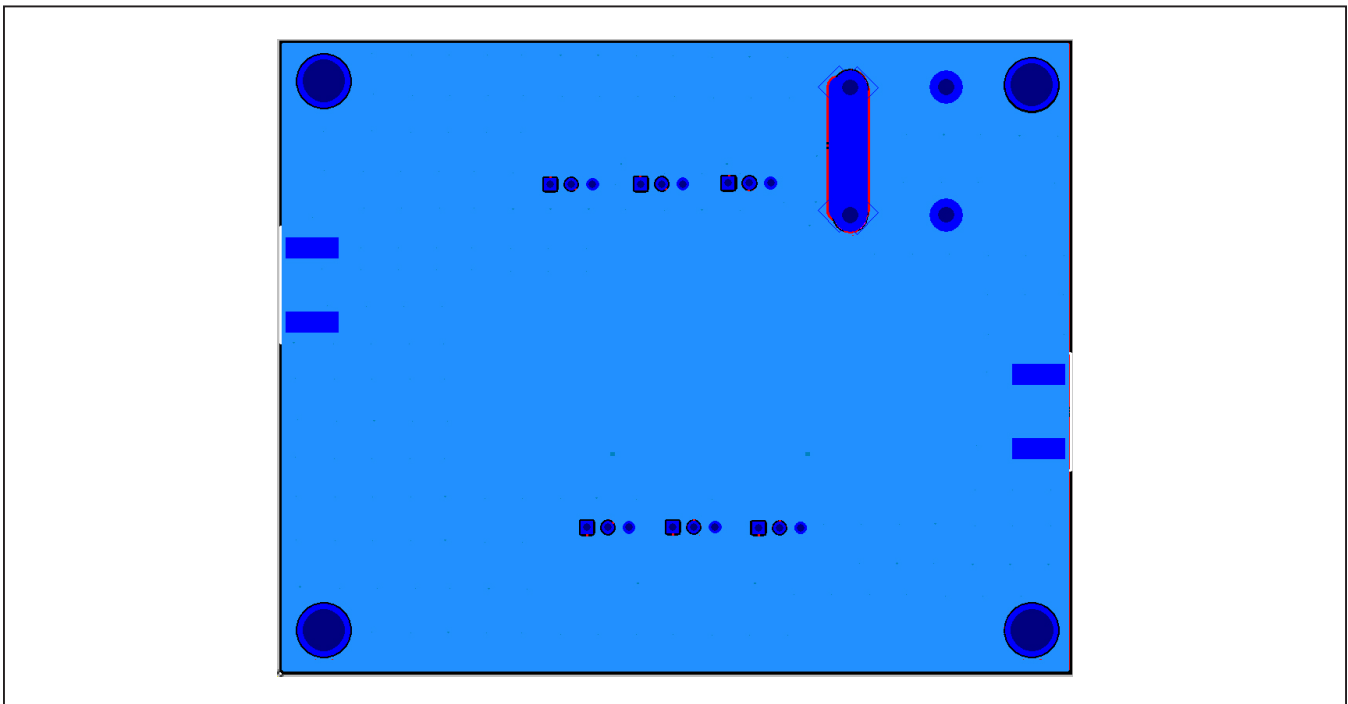

MAX31180 EV Kit—PCB Bottom Layer

Ordering Information

PART	TYPE
MAX31180EVKIT#	EV Kit

#Denotes RoHS compliant.

Revision History

REVISION NUMBER	REVISION DATE	DESCRIPTION	PAGES CHANGED
0	7/17	Initial release	—

For pricing, delivery, and ordering information, please contact Maxim Direct at 1-888-629-4642, or visit Maxim Integrated's website at www.maximintegrated.com.

Maxim Integrated cannot assume responsibility for use of any circuitry other than circuitry entirely embodied in a Maxim Integrated product. No circuit patent licenses are implied. Maxim Integrated reserves the right to change the circuitry and specifications without notice at any time.