

# MAX34565 Evaluation Kit

## Evaluates: MAX34565

### General Description

The MAX34565 evaluation kit (EV kit) simplifies evaluation of the MAX34565 12V hot-plug switch. The EV kit is shipped with a 15Ω current-limit resistor (R2) installed, but this value can be changed from 12Ω to 30Ω to match the application. The EV kit is also shipped with a Kelvin current-sense arrangement, but this can be changed to a direct current-sense arrangement by adding a 0Ω jumper in the R3 position.

**Note:** The PCB used for the MAX34565 EV kit also supports the MAX34564. The two devices share the same footprint. **The PCB silkscreen shows the MAX34564, but if a white label exists on the top side of the PCB, the MAX34565, not the MAX34564, is mounted on the board.**

### EV Kit Contents

- ◆ MAX34565 EV Kit Board

### Component List

DESIGNATION	QTY	DESCRIPTION
C1	1	0.1μF, 25V X7R ceramic capacitor (0805) Venkel C0805X7R250-104KNE
C2	1	2.2μF, 25V X5R ceramic capacitor (0805) Murata GRM21BR61E225K
C3	1	270pF X7R ceramic capacitor (0805) Venkel C0805X7R500-271KNE
J1	1	Red banana jack
J2	1	Black banana jack
J3	1	Blue banana jack
R1	1	0Ω ±1% resistor (0805) Venkel CR0805-10W-000T
R2	1	15Ω ±1% resistor (0805) Venkel CR0805-10W-15R0FT
R3	1	Resistor, do not populate
TP1–TP7	7	Test points
U1	1	12V hot-plug switch (10 TDFN-EP*) Maxim MAX34565ETB+

\*EP = Exposed pad.

### Features

- ◆ Quick Evaluation of the MAX34565
- ◆ Fully Assembled and Tested
- ◆ Ready for Operation Out of the Box
- ◆ Adjustable Current Threshold
- ◆ Supports Both Kelvin and Direct Current Sensing
- ◆ Labeled Test Points for Key Signals
- ◆ PCB Mounting Holes

### Equipment Needed

The following equipment is required to use the MAX34565 EV kit:

- 12V (6A) DC power supply
- Active or passive power load capable of sinking up to 6A

### MAX34565 Evaluation Kit

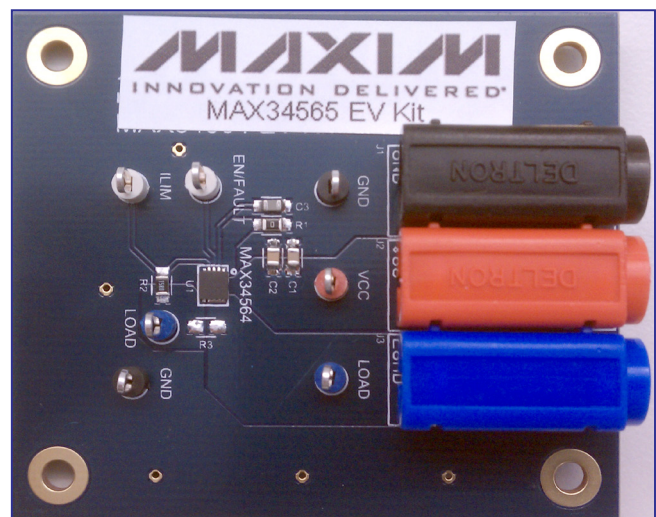

[Ordering Information](#) appears at end of data sheet.

# MAX34565 Evaluation Kit

## Evaluates: MAX34565

### Getting Started

- Connect a high-power 12V (6A) DC power supply to the red (+) and black (-) banana jacks. Do not apply power.
  - Connect a variable (0 to 6A) load between the blue (+) and black (-) banana jacks.
  - Set the load to sink 1A.
  - Turn on the 12V DC power supply.
  - Check the DC voltage drop from VCC to LOAD. It should be approximately 70mV.
  - Decrease the variable load value (increase the current flow) until current stops flowing. The trip point should be approximately 4.5A.
  - The MAX34565 latches off and VCC must be powered cycled to reset the device.
- Note:** Use short leads to minimize inductance. Doing so helps protect the MAX34565 from being exposed to voltages greater than the maximum allowable.

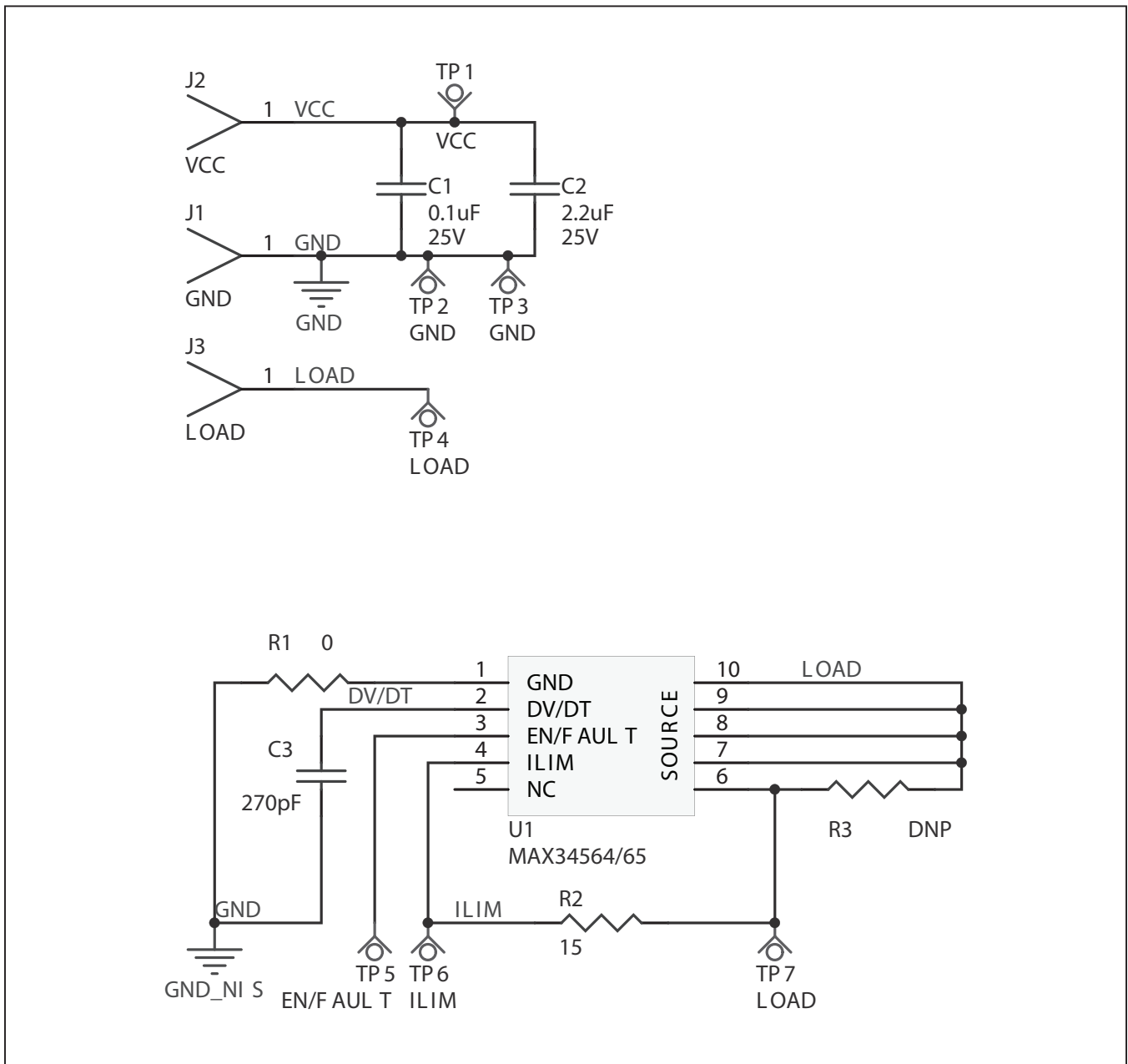

Figure 1. MAX34565 EV Kit Schematic

# MAX34565 Evaluation Kit

## Evaluates: MAX34565

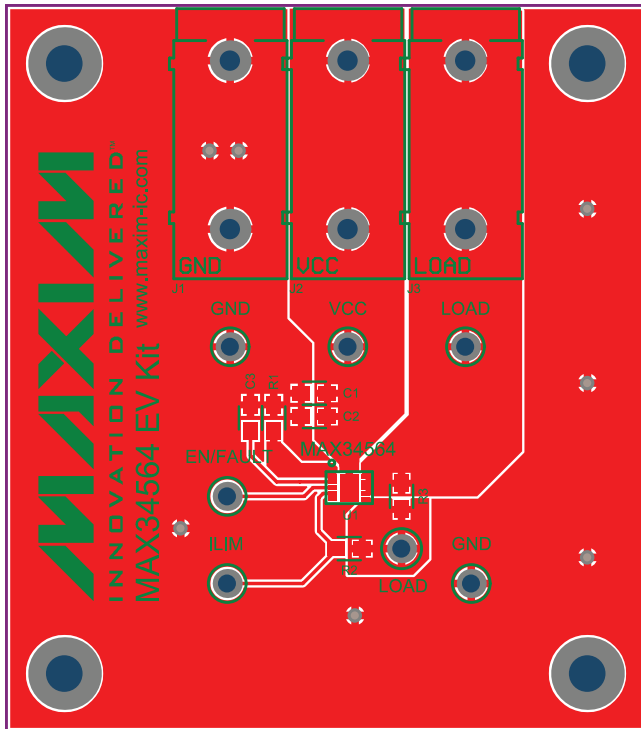

Figure 2. MAX34564/MAX34565 EV Kit PCB Top

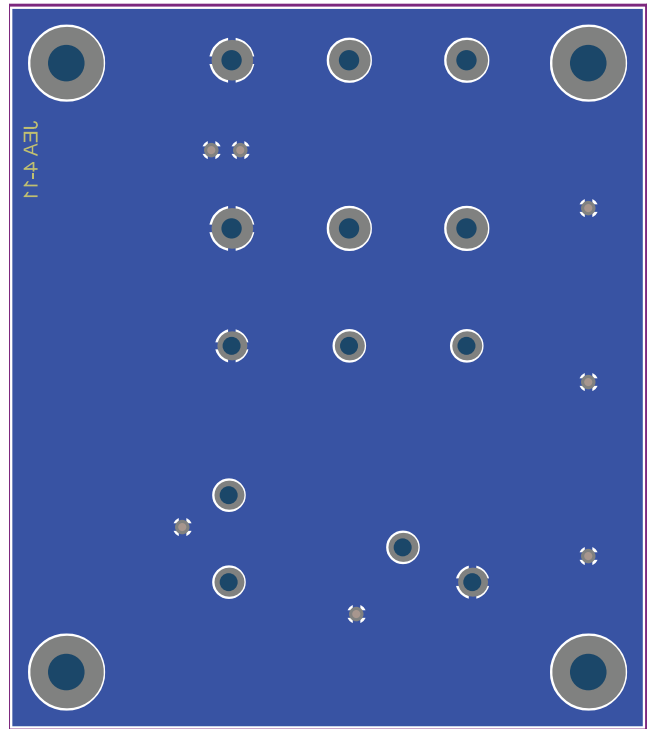

Figure 3. MAX34564/MAX34565 EV Kit PCB Bottom

# MAX34565 Evaluation Kit

## Evaluates: MAX34565

### ***Ordering Information***

---

<b>PART</b>	<b>TYPE</b>
MAX34565EVKIT#	EV Kit

*#Denotes RoHS compliant.*

# MAX34565 Evaluation Kit

## Evaluates: MAX34565

### Revision History

REVISION NUMBER	REVISION DATE	DESCRIPTION	PAGES CHANGED
0	7/12	Initial release	—

Maxim cannot assume responsibility for use of any circuitry other than circuitry entirely embodied in a Maxim product. No circuit patent licenses are implied. Maxim reserves the right to change the circuitry and specifications without notice at any time.

**Maxim Integrated Products, Inc. 160 Rio Robles, San Jose, CA 95134 USA 1-408-601-1000 \_\_\_\_\_ 5**