

MAX35103EVKIT2 Evaluation Kit

Evaluates: MAX35103, MAX32620

General Description

The MAX35103EVKIT2 provides an application example using the MAX35103 time-to-digital converter to measure water flow as part of an off-the-shelf residential irrigation system. The kit includes a PCB and ultrasonic transducer assembly that can be added to standard 24VAC irrigation systems to provide enhanced shut-off irrigation control.

The kit features a MAX32620 Arm® Cortex®-M4 low-power MCU that executes application firmware. Debug support is provided by a 10-pin JTAG connector and a 3.3V TTL UART connector. Future Mbed™ support is provided by the included MAX32625PICO module.

The kit is designed to be inserted between a 24VAC irrigation controller and an irrigation valve. The valve and controller are optional and are not included but can easily be obtained at most home improvement retailers.

Benefits and Features

- Easy Evaluation of the MAX35103 in an Embedded Environment.
- Audiowell Ultrasonic DN20 Ultrasonic Transducer Assembly
- IAR Arm Development Environment Supported
- Flexible Input Power Options for Desktop or Field Development Enabled by the MAX15062

Ordering Information appears at end of data sheet.

Arm and Cortex are registered trademarks and Mbed is a trademark of Arm Limited (or its subsidiaries) in the US and/or elsewhere.

MAX35103EVKIT2 Example Application

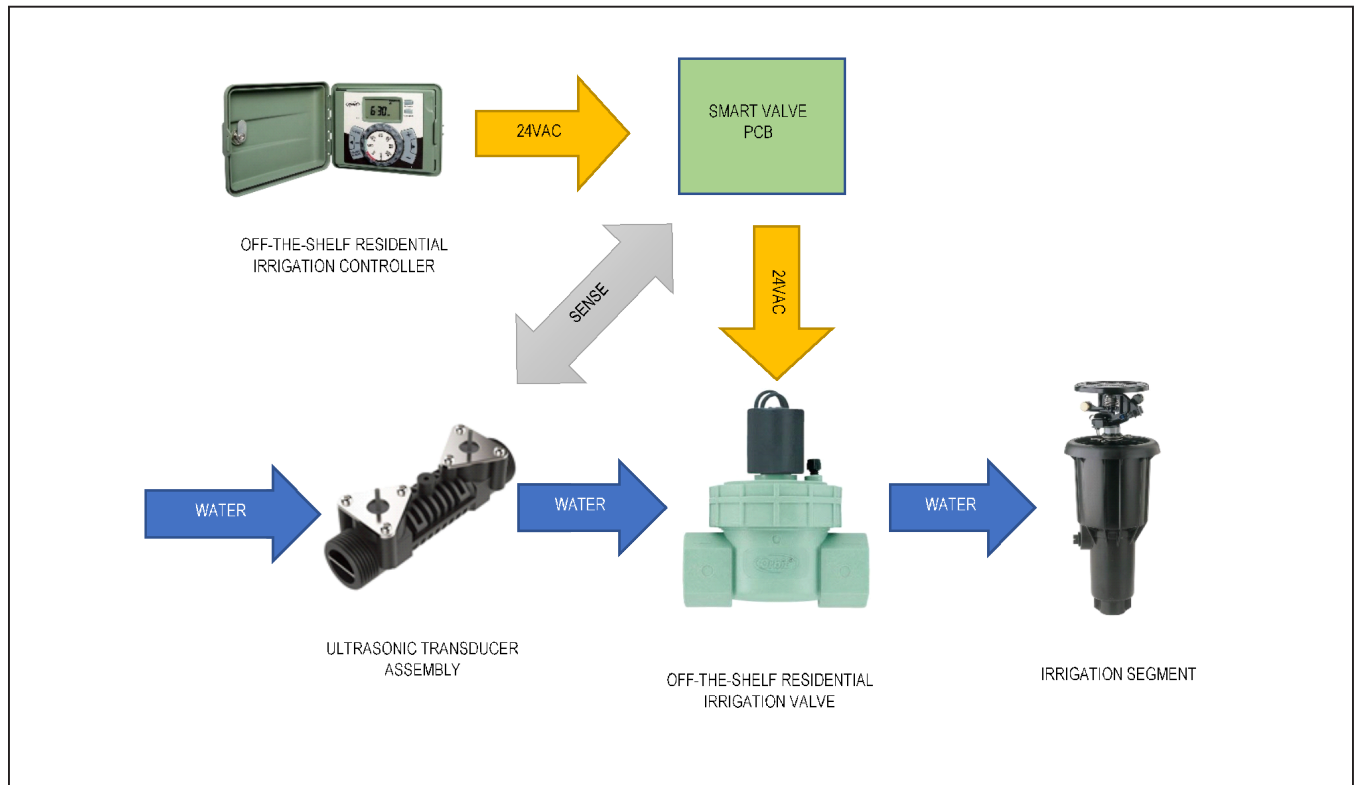

MAX35103EVKIT2 Files

FILE	DESCRIPTION
MAX35103EVKIT2.ZIP	Firmware Package

Quick Start

Required Equipment

Included:

- PCB containing the MAX35103 time-to-digital converter
- Audiowell ultrasonic DN20 transducer

Optional equipment not included:

- 24VAC irrigation controller
- 24VAC irrigation valve
- IAR-compatible Arm JTAG adapter with 10-pin Arm connector (for IAR support)
- FTDI TTL-232R-3V3 USB serial port cable or compatible (for IAR-based debug support)
- PC running terminal software
- 24V AC/DC benchtop power supply or power adapter

Procedure

The MAX35103EVKIT2 can be quickly evaluated without access to an irrigation system as follows. See [Figure 1](#) for J2 connection details.

- 1) Connect one transducer wire pair from the transducer to the piezo up J2 screw terminals.
- 2) Connect the other transducer wire pair from the transducer to the piezo down J2 screw terminals.
- 3) Fill the ultrasonic transducer assembly with water or completely immerse the transducer in water.
- 4) Apply 9V to 24V AC or DC power to the PCB through the J2 screw terminal block. The silkscreen on the bottom of the PCB identifies the two POWER connectors.
- 5) Observe the red LED (D1) illuminate continually.
- 6) Observe the green LED (D2) blinking to indicate that the board and the water-filled transducer is operating correctly.

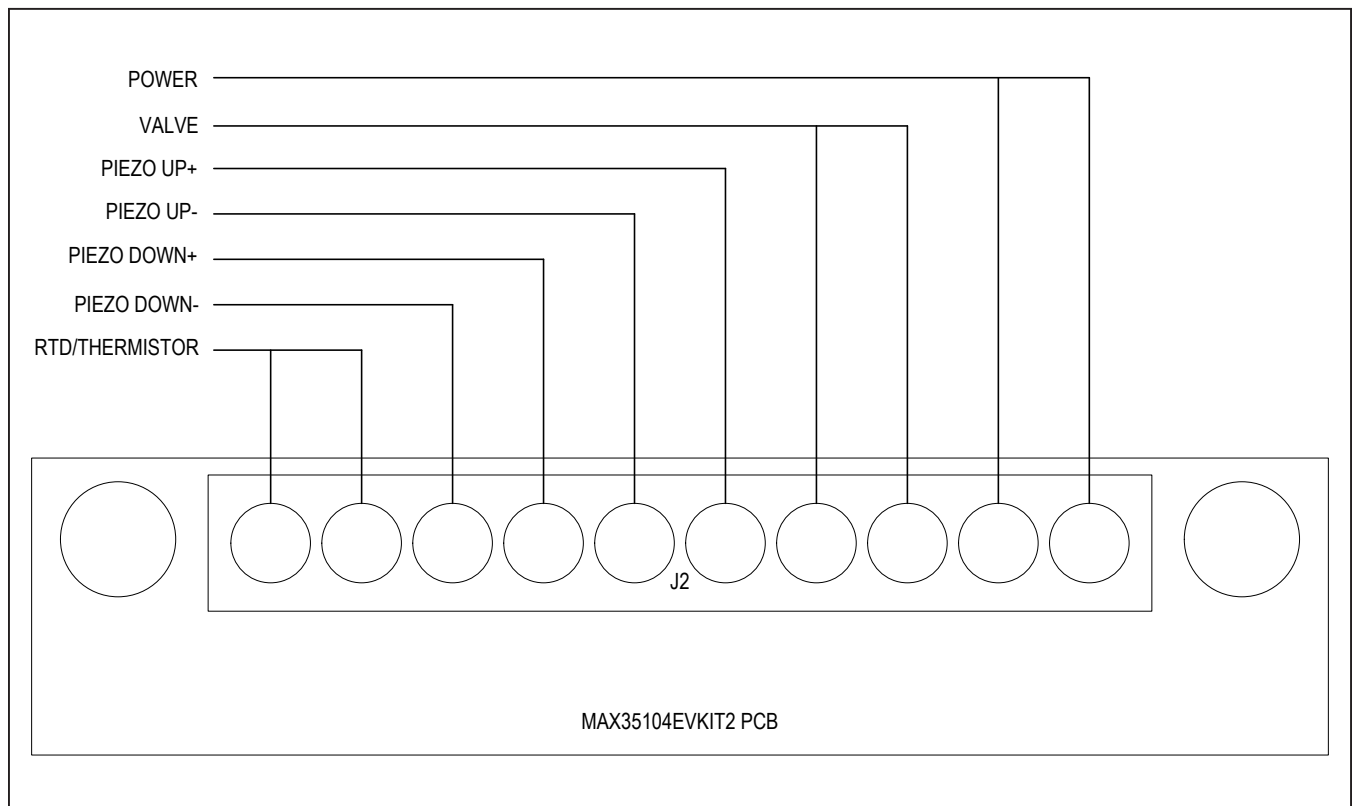

Figure 1. J2 Screw Terminal Pinout

Preloaded Test Firmware

The preloaded test firmware flashes the green LED (D2) when water is detected within the transducer assembly. This provides a quick, out-of-the box test to validate the PCB and the transducer.

If the green LED does not stay illuminated, then there could be a connection problem between the transducer assembly and the J2 screw terminal or the transducer might not be completely filled with water. Be sure to evacuate all air from the transducer assembly by tapping or shaking it. A small air bubble lodged against one of the piezo elements or reflectors can cause the test to fail.

The red LED (D1) should illuminate continually and indicates that power is being supplied correctly.

The IAR Arm test firmware is provided for reference in the firmware package associated with this kit.

Hardware Description

The PCB depicted in [Figure 2](#) features a number of Maxim technologies. Power conversion is handled by the MAX15062 buck converter and MAX1963 and MAX8891 LDOs. This allows the board to accept a wide range of input power, including 24VAC power that is widely used in the residential irrigation market.

A solid state relay circuit allows efficient and reliable control of 24VAC solenoid-based water valves. The circuit features a Omron G3VM-61GR1 1.0A MOSFET relay.

Ultrasonic flow sensing is accomplished with the help of the MAX35103 time-to-digital converter. The converter can also be used to sample an externally connected thermistor or RTD.

For debugging and system expansion, a 3.3V TTL UART header is provided.

Debugging and firmware programming can be accomplished using the 10-pin Arm JTAG header.

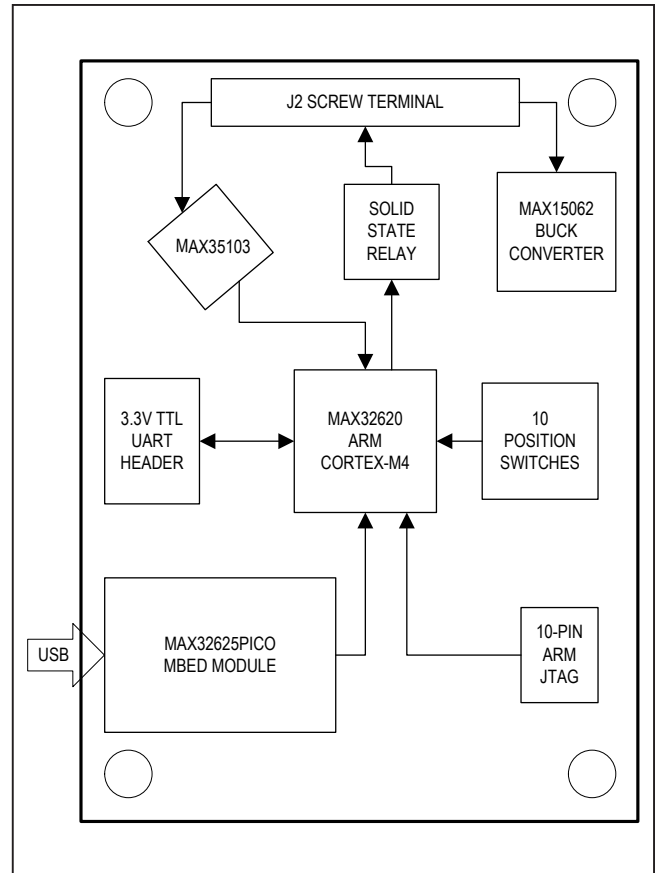

Figure 2. PCB Block Diagram

Two 10-position rotary switches are provided for a simple means of configuring the example application firmware.

The low-power requirements of the MAX32620 Arm Cortex-M4 and the MAX35103 allow the board to use power provided by the irrigation controller normally allocated to the water valve.

Audiowell DN15 Ultrasonic Transducer Assembly

The MAX35103EVKIT2 features the Audiowell DN15 ultrasonic transducer assembly. This is a low-cost ultrasonic sensor with 3/4in NTP male connections for easy interface with standard North American residential irrigation systems.

Example Application Firmware

The firmware package associate with the this evaluation kit contains example firmware and the MAX35103 API. This package can be downloaded from the Maxim website. The part number is SFW0000330A.



Figure 3. Ultrasonic Transducer Assembly

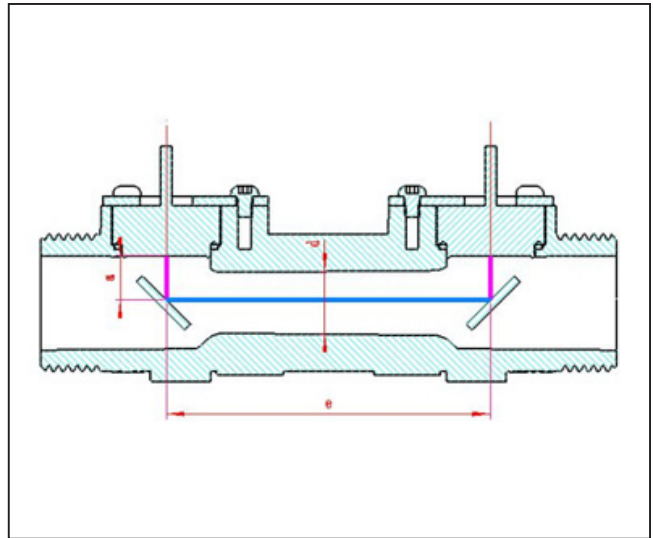

Figure 4. Transducer Assembly Cross Section

Table 1. Dimension for Figure 4

	A (mm)	B (mm)	C (mm)
DN15	8.25	62	12

Component List

DESIGNATION	QTY	DESCRIPTION
C1, C2, C6, C7	4	0.01 μ F 100V X7R 10% (0603) capacitors Murata GCM188R72A103KA37D
C3	1	2.2 μ F 100V X7S 10% (1206) capacitor TDK C3216X7S2A225K160AB
C4, C8, C9, C34	4	1 μ F 25V X5R 10% (0603) capacitors Murata GRM188R61E105KA12D
C5	1	10 μ F 10V X5R 10% (0805) capacitors Murata GRM21BR61A106KE19L
C10, C11	2	2.2 μ F 16V X5R 10% (0603) capacitors Murata GRM188R61C225KE15D
C12, C14, C15, C16, C17, C18, C20, C21, C26, C31, C32, C33	12	0.1 μ F 50V X7R 10% (0603) capacitors Murata GRM188R71H104KA93D
C22, C24, C25, C28, C29, C30	6	12pF 50V C0G 5% (0603) capacitors Murata GRM1885C1H120JA01D
C23, C27	2	1000pF 50V X7R 10% (0603) capacitors Murata GRM188R71H102KA01D
D1	1	Red LED Kingbright AP2012EC
D2	1	Green LED Kingbright APT2012CGCK
J1	1	10-position 1.27mm x 1.27mm header FCI 20021121-00010C4LF
J2	1	10-position fixed terminal block Phoenix Contact 1725737
J3	1	6-position 2.54mm header Molex 87898-0666

DESIGNATION	QTY	DESCRIPTION
L1, L3, L4, L5	4	470 Ω ferrite beads (0603) Murata BLM18PG471SN1D
L2	1	33 μ H 30% 0.45A inductor Bourns SRN3015TA-330M
R1, R2, R6	3	150 Ω 0.5% 1/16W 25ppm (0603) resistors Susumu RR0816P-151-D
R3, R5	2	470 Ω 0.5% 1/16W 25ppm (0603) resistors Susumu RR0816P-471-D
R4	1	1k Ω 0.5% 1/16W 25ppm (0603) resistor Susumu RR0816P-102-D
R7	1	22k Ω 0.5% 1/16W 25ppm (0603) resistor Susumu RR0816P-223-D
R8	1	510 Ω 0.5% 1/16W 25ppm (0603) resistor Susumu RR0816P-511-D
R9	1	220 Ω 0.5% 1/16W 25ppm (0603) resistor Susumu RR0816P-221-D
S1, S2	2	10-position coded rotary switches CTS 221AMA10R
U1	1	0.5A bridge rectifier Fairchild Semiconductor MB1S
U2	1	Buck switching regulator Maxim MAX15062AATA+T
U3	1	1.2V LDO Maxim MAX1963AEZT120+T
U4	1	1.8V LDO Maxim MAX8891EXK18+T
U5	1	Arm Cortex-M4 Maxim MAX32620ICQ+

Component List (continued)

DESIGNATION	QTY	DESCRIPTION
U6	1	Time-to-digital converter Maxim MAX35103EHJ+
U7	1	I/O buffer Fairchild Semiconductor NC7WZ16P6X
U8	1	Solid-state relay Omron G3VM-61GR1
U9, U13	2	40V TVS diodes STMicroelectronics SMAJ40CA-TR

DESIGNATION	QTY	DESCRIPTION
U10	1	EEPROM Maxim DS28EL22Q+U
U11	1	Mbed module Maxim MAX32625PICO-CO
U12	1	I/O voltage level shifter Maxim MAX13032EETE+
X1	1	4MHz crystal Abracon ABLS-4.000MHZ-B2-T
X2	1	32.768kHz crystal ECS ECS-.327-12.5-17X-C-TR

Component Suppliers

SUPPLIER	PHONE	WEBSITE
Audiowell	+86 20 84802041	www.audiowell.com
Murata	+81 75 951 9111	www.murata.com
ON Semiconductor/Fairchild Semiconductor	011 421 33 790 2910	www.onsemi.com
STMicroelectronics	1 (844) STMICRO	www.st.com
Abracon	(949)546-800	www.abracon.com
ECS	(913)782-7787	www.ecsxtal.com
Omron	(224)520-7650	www.omron.com
CTS	See website	www.ctscorp.com
Susumu	(201) 461-4861	www.susumu.co.jp
Bourns	(951) 781-5500 ext. 2778	www.bourns.com
Phoenix Context	(717) 944-1300	www.phoenixcontact.com
Kingbright	+886 2 22499224	www.kingbright.com
FCI	1 (800) 237-2374	www.fci.com
TDK	(516) 535-2600	www.tdk.com

Ordering Information

PART	TYPE
MAX35103EVKIT2#	EV Kit

#Denotes RoHS compliant.

MAX35103 EV Schematic (CPU)

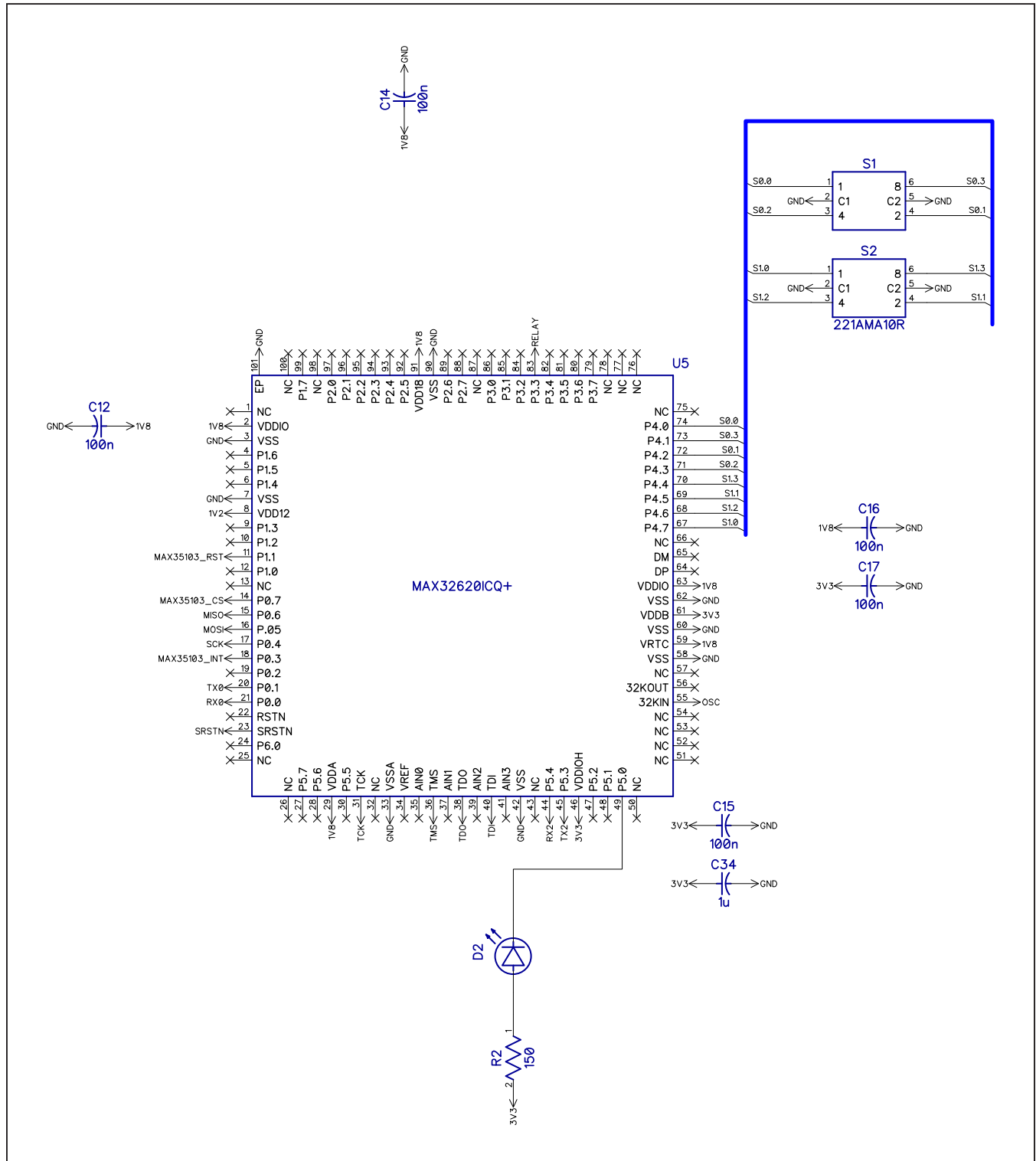

MAX35103 EV Schematic (Ultrasonic Sensor Interface)

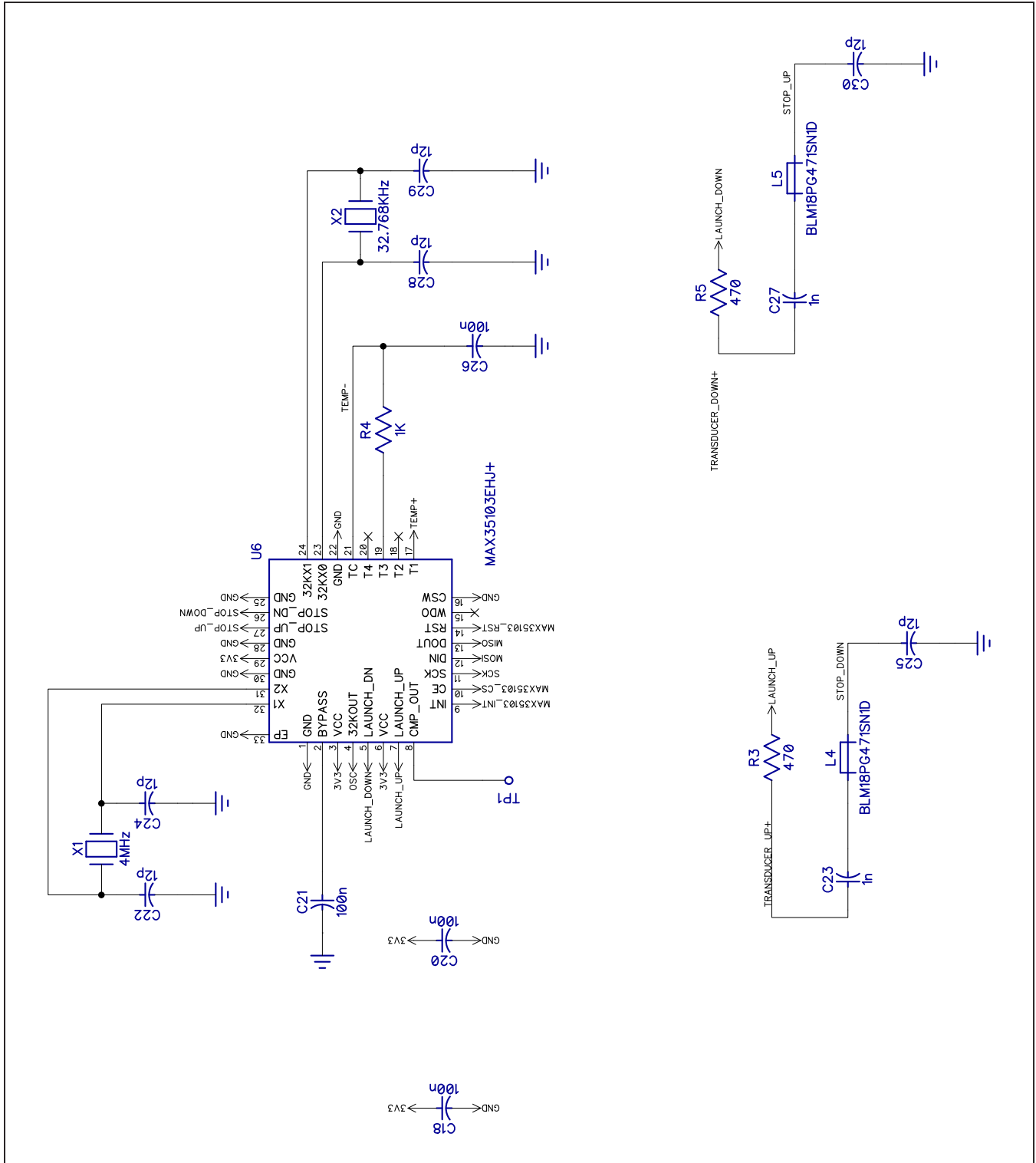

MAX35103 EV Schematic (I/O)

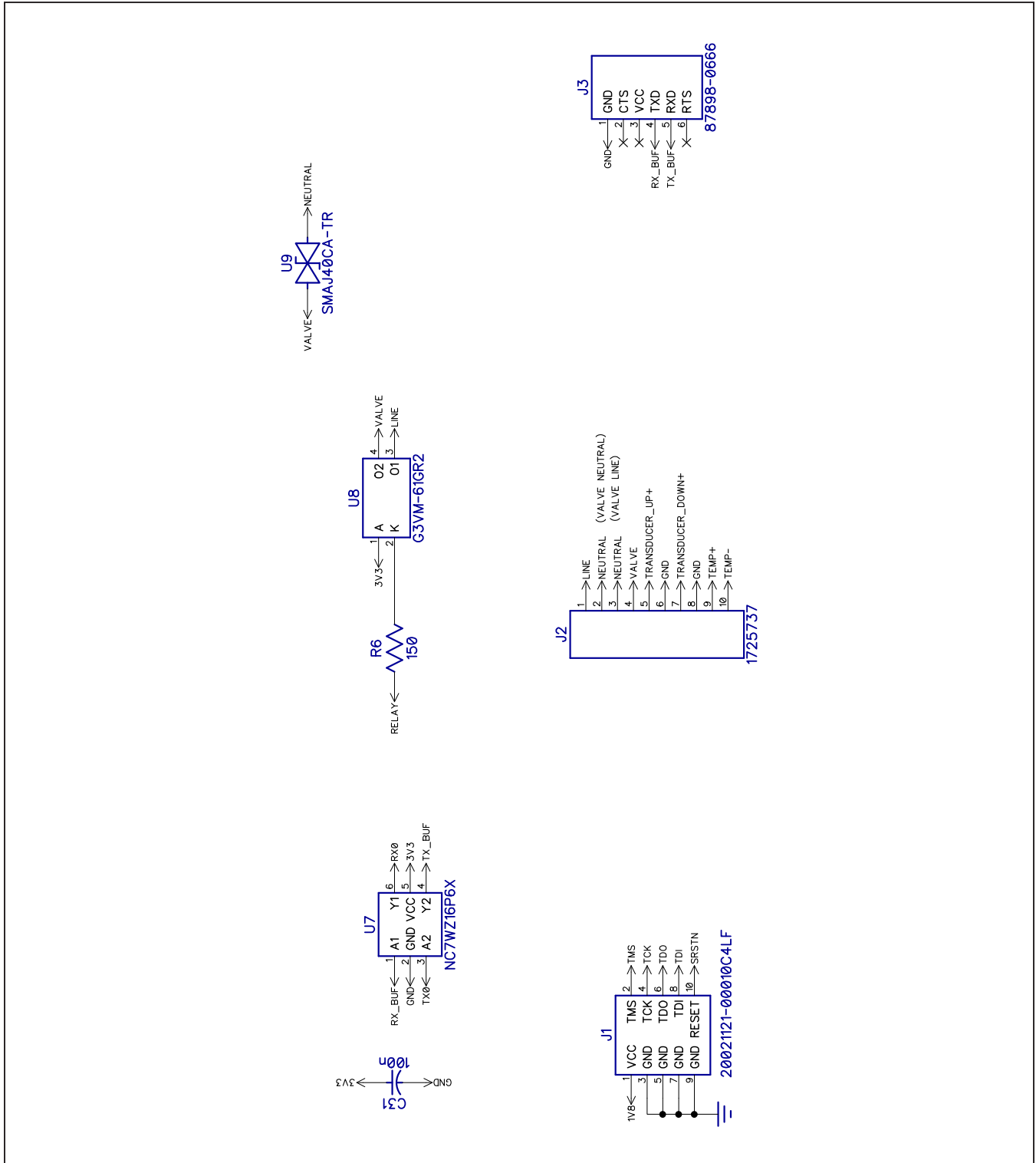

MAX35103 EV Schematic (Mbed Module)

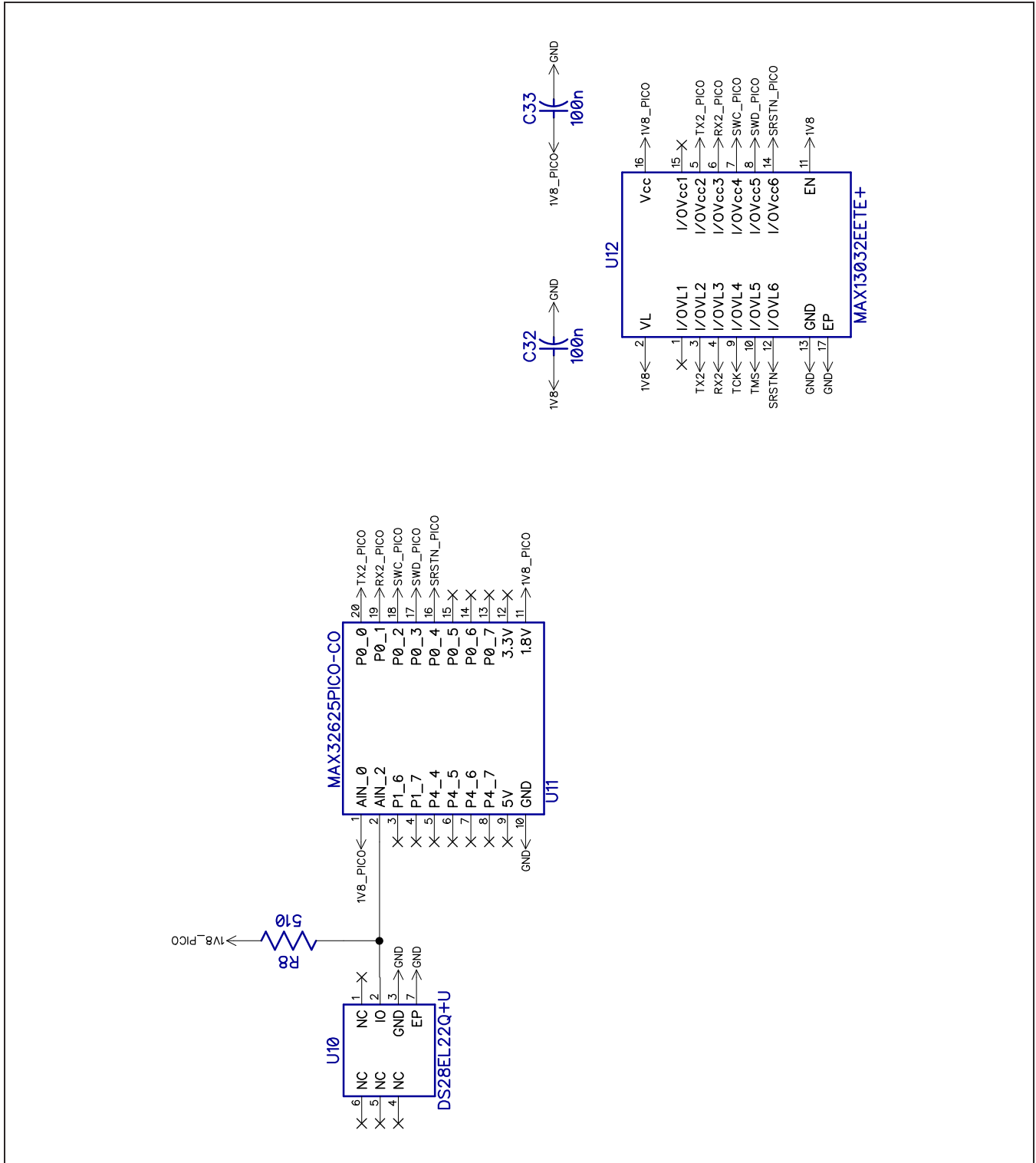

MAX35103 EV PCB Layouts

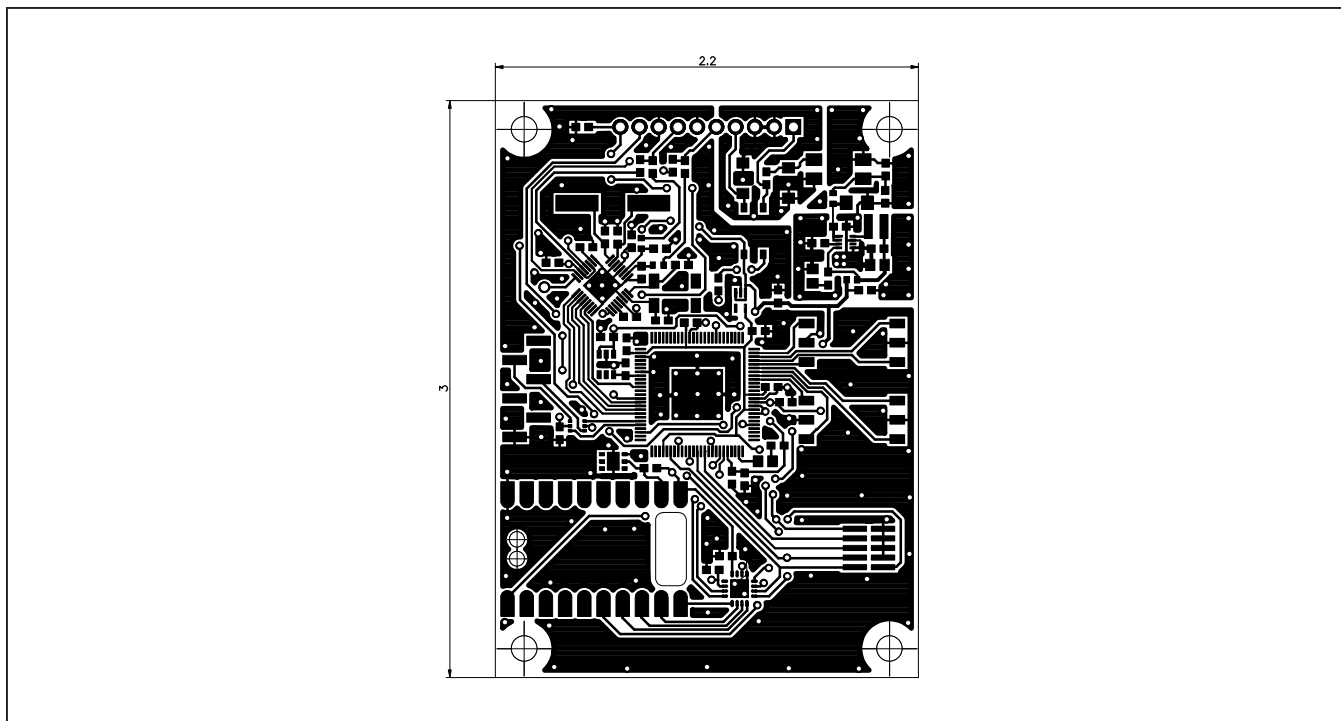

Top Silkscreen

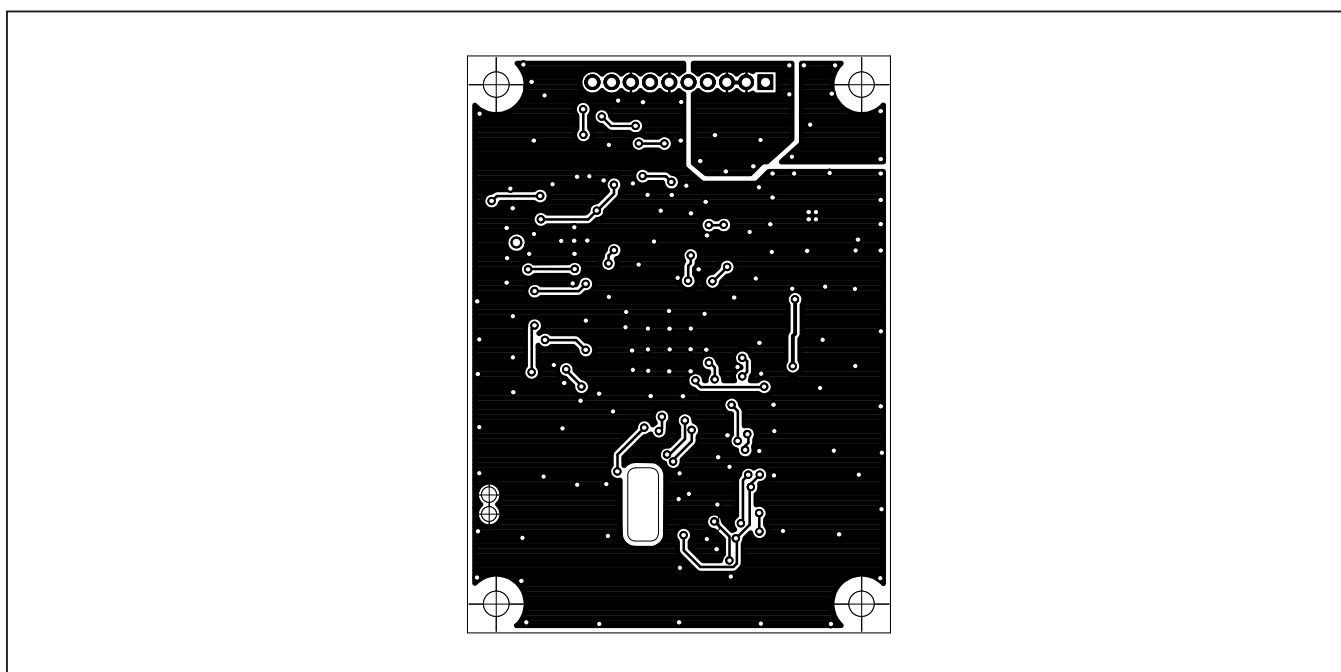

Bottom Silkscreen

Revision History

REVISION NUMBER	REVISION DATE	DESCRIPTION	PAGES CHANGED
0	11/17	Initial release	—

For pricing, delivery, and ordering information, please contact Maxim Direct at 1-888-629-4642, or visit Maxim Integrated's website at www.maximintegrated.com.

Maxim Integrated cannot assume responsibility for use of any circuitry other than circuitry entirely embodied in a Maxim Integrated product. No circuit patent licenses are implied. Maxim Integrated reserves the right to change the circuitry and specifications without notice at any time.