

EVALUATION KIT
AVAILABLE



150Mbps Automotive VCSEL Driver

MAX3905

General Description

The MAX3905 150Mbps automotive VCSEL driver implements low-cost transmitters operating from 8Mbps to 150Mbps at junction temperatures up to +140°C. The device accepts single-ended TTL, differential PECL or LVDS input data, and provides bias and modulation currents for driving a VCSEL. The output is DC-coupled to the VCSEL to minimize component count.

The driver provides temperature compensation to VCSEL high and low currents. Adjustments of the bias current, modulation current, bias-current temperature coefficient, and center of the temperature-stable bias current region are all programmable by wirebond options. The power-reduction feature decreases output modulation by approximately 50%. The data squelch feature disables the VCSEL current when no data is present.

The MAX3905 is available in die form and operates from -40°C to +140°C junction temperature, over a +3.0V to +5.25V supply range.

Applications

Optical Transmitters for Automotive Networks
Polymer-Clad Silica Fiber-Based Networks

Features

- ◆ -40°C to +140°C Operating Junction Temperature Range
- ◆ +3.0V to +5.25V Supply Voltage
- ◆ TTL/CMOS-, LVDS-, or PECL-Compatible Data Input
- ◆ Compatible with SP1 Automotive Network Interface
- ◆ Wirebond-Adjustable VCSEL Low and High Currents
- ◆ Optical Power-Reduction Feature
- ◆ Output Squelch

Ordering Information

PART	TEMP RANGE	PIN-PACKAGE
MAX3905E/D	-40°C to +140°C	Dice*

*Dice are designed to operate from $T_J = -40^\circ\text{C}$ to $+140^\circ\text{C}$, but are tested and guaranteed at $T_A = +49^\circ\text{C}$ only.

Typical Application Circuits

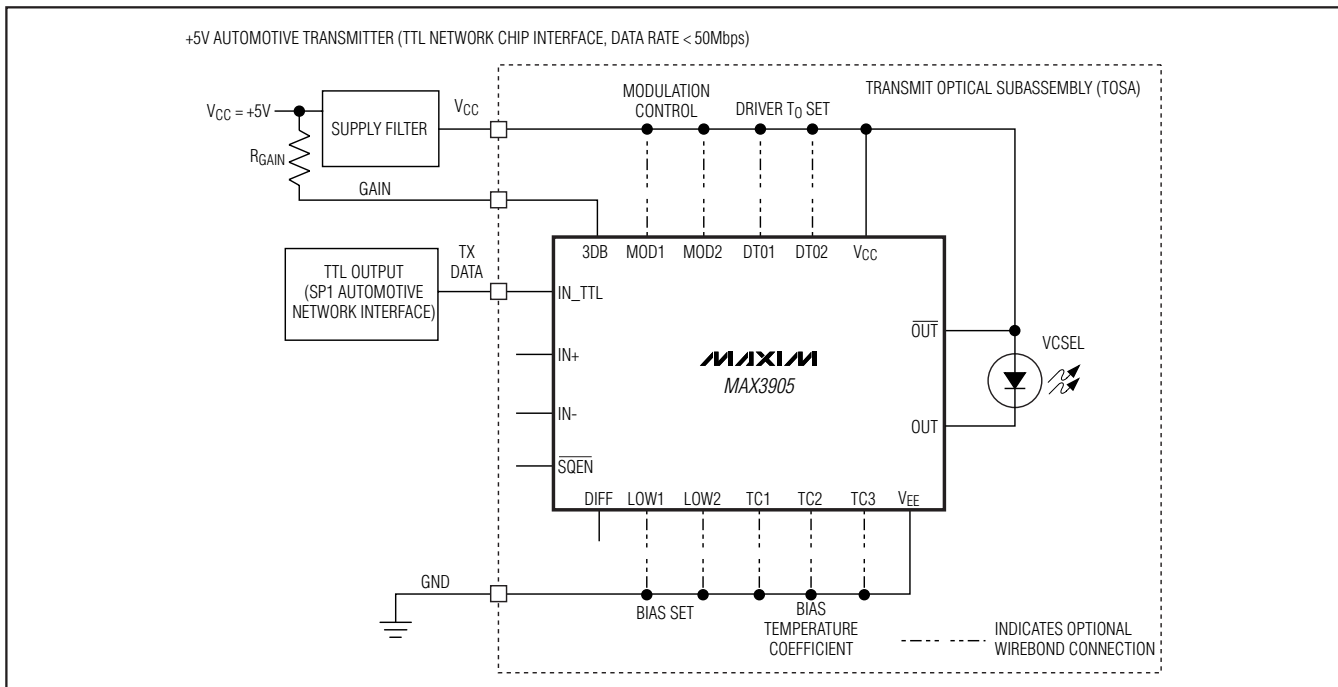

Typical Application Circuits continued at end of data sheet.

150Mbps Automotive VCSEL Driver

ABSOLUTE MAXIMUM RATINGS

Supply Voltage, (V_{CC} - V_{EE})-0.5V to +6.0V
 Voltage at 3DB, IN+, IN-, IN_TTL, DIFF, OUT, OUT,
 MOD1, MOD2, DT01, DT02, SQEN,
 TEMPSENS-0.5V to (V_{CC} + 0.5V)
 Voltage at LOW1, LOW2, TC1, TC2, TC3.....-0.5V to +2V
 Differential Input Voltage IIN+ - IN-I.....V_{CC}
 Current into OUT.....+12mA

Storage Ambient Temperature Range.....-65°C to +150°C
 Operating Junction Temperature Range.....-40°C to +150°C
 Electrostatic Discharge (ESD)
 (Human Body Model, tested per JES D22-A114)2kV
 (Machine Model, tested per JES D22-A115).....+400V
 Die Attach Temperature.....+400°C

Stresses beyond those listed under "Absolute Maximum Ratings" may cause permanent damage to the device. These are stress ratings only, and functional operation of the device at these or any other conditions beyond those indicated in the operational sections of the specifications is not implied. Exposure to absolute maximum rating conditions for extended periods may affect device reliability.

ELECTRICAL CHARACTERISTICS

(V_{CC} = +3.0V to +5.25V, T_J = -40°C to +140°C. Typical values are at V_{CC} = +5.0V and T_A = +25°C, unless otherwise noted.)

PARAMETER	SYMBOL	CONDITIONS	MIN	TYP	MAX	UNITS
OPERATING CONDITIONS						
Voltage at OUT	V _{OUT}		0.9			V
Data Rate		With TTL input	8		50	Mbps
		With differential input	40		150	
TTL Data Input-Edge Transition Time		One-pole response, 10% to 90%			0.23	UI
POWER SUPPLY						
Supply Current	I _{CC}	Excludes I _{OUT} and I _{OUT}		14	25	mA
Supply Current While Data is Squelched	I _{STDBY}	Excludes I _{OUT} and I _{OUT}		14		mA
CURRENT GENERATOR						
Low Current (T _J = DT ₀)	IDT ₀	LOW1 open, LOW2 open	1.69	1.8	1.91	mA
		LOW1 GND, LOW2 open	2.02	2.17	2.28	
		LOW1 open, LOW2 GND	2.35	2.53	2.65	
		LOW1 GND, LOW2 GND	2.68	2.90	3.02	
Low-Current Positive Temperature Coefficient (T _J > DT ₀)	TCL _{LOW+}	TC1 open, TC2 open, TC3 open	12	16	18	μA/°C
		TC1 GND, TC2 open, TC3 open	16	21	24	
		TC1 GND, TC2 GND, TC3 open	24	32	36	
		TC1 GND, TC2 GND, TC3 GND	36	48	54	
Low-Current Negative Temperature Coefficient (T _J < DT ₀)	TCL _{LOW-}	TC1 open, TC2 open, TC3 open	-18	-16	-12	μA/°C
		TC1 GND, TC2 open, TC3 open	-24	-21	-16	
		TC1 GND, TC2 GND, TC3 open	-36	-32	-24	
		TC1 GND, TC2 GND, TC3 GND	-54	-47	-36	
Width of Temperature-Stable Low-Current Region	T _W		38	45	52	°C
Center of Temperature-Stable Low-Current Region	DT ₀	DT01 open, DT02 open	31.5	36	41.5	°C
		DT01 V _{CC} , DT02 open	44	49	54	
		DT01 open, DT02 V _{CC}	56	61	66	
		DT01 V _{CC} , DT02 V _{CC}	68.5	74	78.5	
Modulation-Current Temperature Coefficient	TC _{MOD}	Relative to I _{MOD} at T _J = +25°C	0.311	0.38	0.471	%/°C

150Mbps Automotive VCSEL Driver

MAX3905

ELECTRICAL CHARACTERISTICS (continued)

($V_{CC} = +3.0V$ to $+5.25V$, $T_J = -40^{\circ}C$ to $+140^{\circ}C$. Typical values are at $V_{CC} = +5.0V$ and $T_A = +25^{\circ}C$, unless otherwise noted.)

PARAMETER	SYMBOL	CONDITIONS	MIN	TYP	MAX	UNITS
Modulation Current at $T_J = +25^{\circ}C$	I_{MOD}	MOD1 open, MOD2 open	2.84	3.01	3.22	mA
		MOD1 V_{CC} , MOD2 open	3.44	3.65	3.88	
		MOD1 open, MOD2 V_{CC}	4.03	4.28	4.55	
		MOD1 V_{CC} , MOD2 V_{CC}	4.62	4.91	5.22	
Modulation Current in Low-Power Mode	I_{LP}	Relative to programmed nominal, $T_J = +25^{\circ}C$	40	50	60	%
Modulation Switching Time	t_r, t_f	20% to 80% (Note 1)		0.2	0.5	ns
Pulse-Width Variation	PWV	(Notes 1, 2)	0.97		1.03	UI
Pulse-Width Distortion	PWD	(Notes 1, 2)	-0.02		+0.02	UI
Data-Dependent Jitter	DDJ	(Notes 1, 2)		0.004	0.01	UI
Uncorrelated Jitter	UJ	(Notes 1, 2)			0.001	UI
Deterministic Jitter	DJ	K28.5 pattern at 125Mbps (Notes 1, 3)		85	200	psp-P
Random Jitter	RJ	1-0 pattern differential input (Note 1)		3	11	psRMS
IN_TTL DATA INPUT						
Input Low	V_{INL}		-0.03		+0.80	V
Input High	V_{INH}		2.0		$V_{CC} + 0.3$	V
Input Resistance			4	5.75		k Ω
Input Capacitance		(Note 1)		0.3	2	pF
DIFFERENTIAL DATA INPUT						
Differential-Input Sensitivity				25	200	mVp-P
Differential-Input Overload			1860			mVp-P
Differential-Input Resistance				8		k Ω
3DB INPUT						
Input Threshold Voltage				1.5		V
3DB Input Voltage		Normal mode	2.0			V
		Low-power mode			0.8	
Diagnostic Resistor	R_{GAINN}	$V_{CC} > 4.75V$, normal mode			16	k Ω
	R_{GAINL}	$V_{CC} > 4.75V$, low-power mode	29			
DATA SQUELCH						
Output Current While Squelched	I_{OFF}	No input data		3	50	μA
Time to Squelch	t_{SQ}	(Note 1)	1	8	25	μs
Time to Resume from Squelch State	t_{RS}	(Note 1)		0.1	5	μs
ESD PROTECTION						
IN+, IN-, TTL_IN, 3DB		Human Body Model	± 4			kV
		Machine Model	± 400			V

Note 1: These specifications are guaranteed by design and characterization.

Note 2: Pulse-width variation, pulse-width distortion, data-dependent jitter, and uncorrelated jitter are measured at 45Mbps per MOST specification of physical Layer (revision 1.1).

Note 3: Deterministic jitter is measured with a K28.5 pattern (0011 1110 1011 0000 0101). Deterministic jitter is the peak-to-peak deviation from ideal time crossings, measured at the 50% crossings of the output. Differential data applied to input.

150Mbps Automotive VCSEL Driver

Typical Operating Characteristics

(LOW[1, 2] = [GND, open], MOD[1, 2] = [open, V_{CC}], DT0[1, 2] = [open, open], TC[1, 2, 3] = [GND, GND, open], T_A = +25°C, unless otherwise noted.)

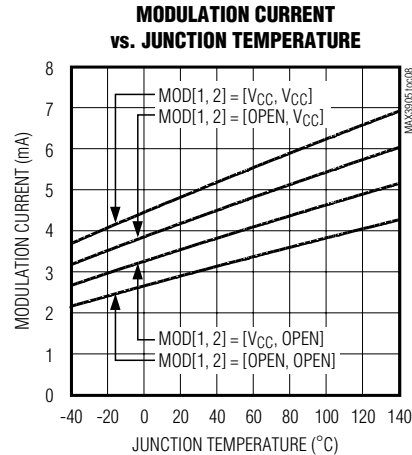
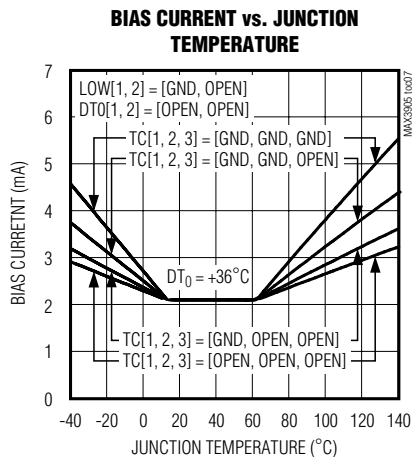
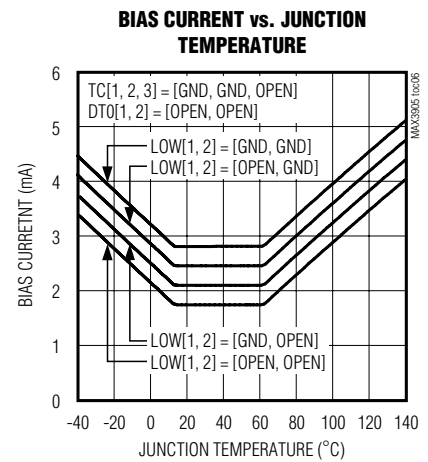
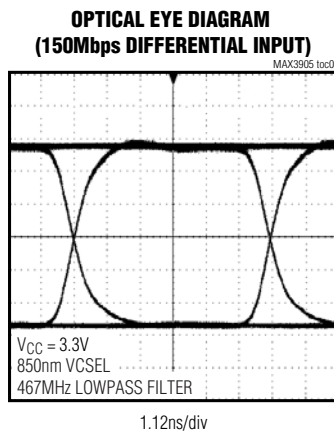
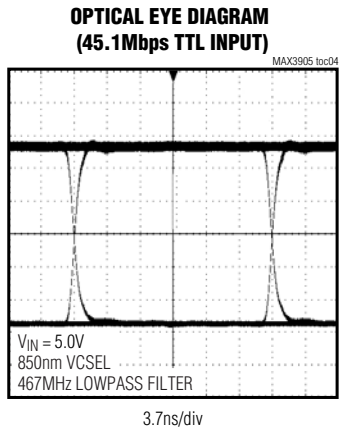
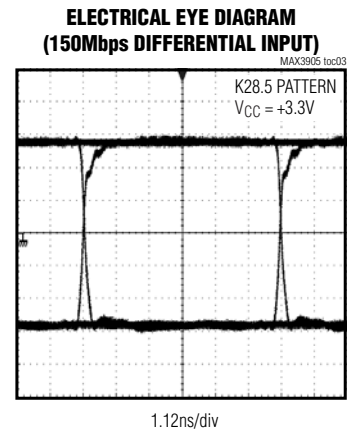
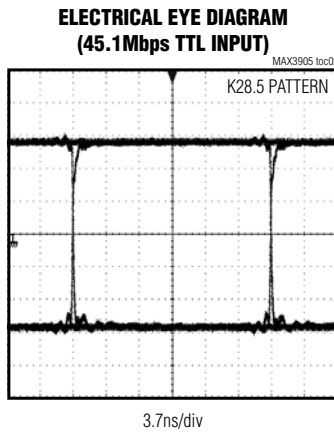
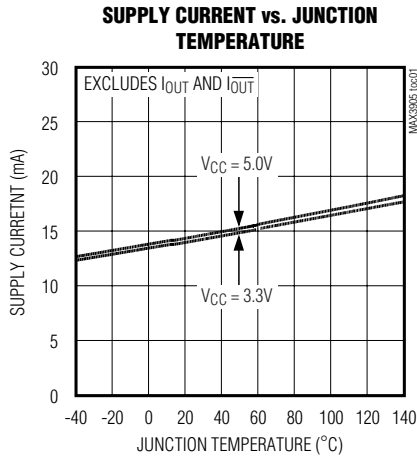

150Mbps Automotive VCSEL Driver

MAX3905

Typical Operating Characteristics (continued)

(LOW[1, 2] = [GND, open], MOD[1, 2] = [open, V_{CC}], DT0[1, 2] = [open, open], TC[1, 2, 3] = [GND, GND, open], T_A = +25°C, unless otherwise noted.)

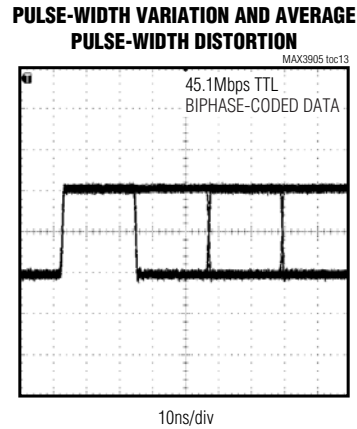
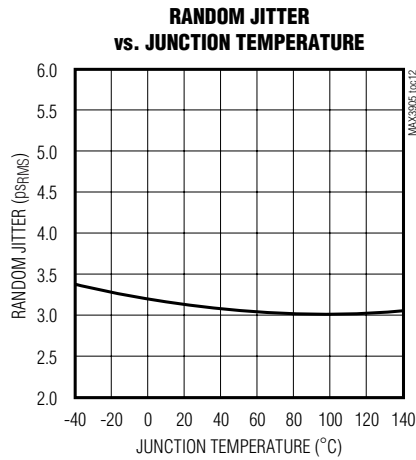
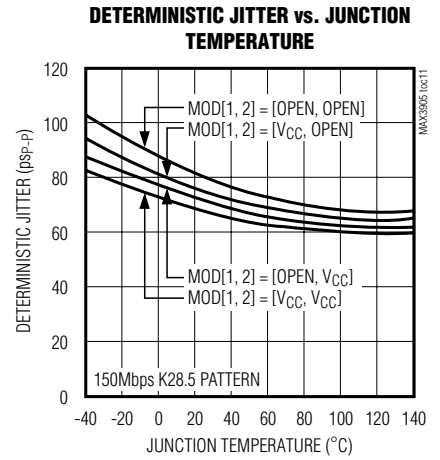
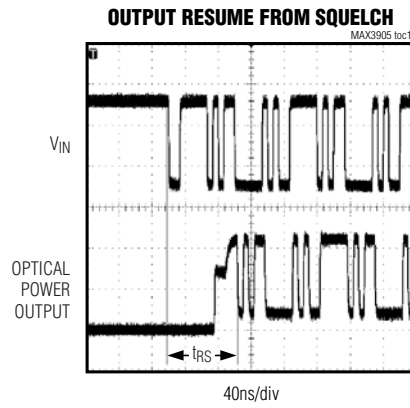
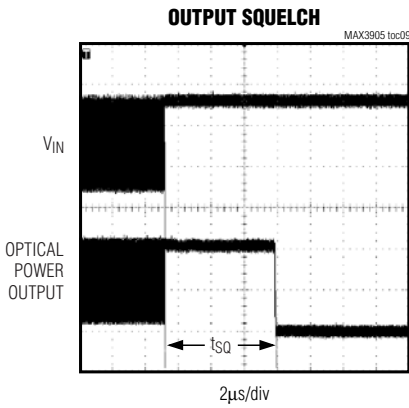

150Mbps Automotive VCSEL Driver

Pad Description

PAD	NAME	FUNCTION
1, 20, 26	VEE	Circuit Ground
2	DIFF	Differential-Input Data Enable. Leave open to enable the TTL data input, or connect to ground to enable the differential data input.
3	IN_TTL	Single-Ended Data Input, TTL. Compatible with SP1 automotive network interface. This input is active when DIFF is left open.
4, 5, 6	N.C.	No Connection
7	IN+	Positive Differential-Data Input, PECL- or LVDS-Compatible. This high-impedance input is internally biased to approximately 1.4V and requires an external termination resistor and an AC-coupling capacitor. It is active when DIFF is connected to ground.
8	TEMPSENS	Junction Temperature Sensor. Analog output corresponding to the junction temperature of the die. Leave open for normal use.
9	IN-	Negative Differential-Data Input, PECL- or LVDS-Compatible. This high-impedance input is internally biased to approximately 1.4V and requires an external termination resistor and an AC-coupling capacitor. It is active when DIFF is connected to ground.
10, 15	V _{CC}	Power Supply
11	DT01	Driver T ₀ Programming Input. Sets the center temperature of lowest bias current. Connect to V _{CC} or leave open.
12	DT02	Driver T ₀ Programming Input. Sets the center temperature of lowest bias current. Connect to V _{CC} or leave open.
13	MOD2	Modulation-Current Programming Input. Sets the modulation-current amplitude. Connect to V _{CC} or leave open.
14	MOD1	Modulation-Current Programming Input. Sets the modulation-current amplitude. Connect to V _{CC} or leave open.
16	$\overline{\text{OUT}}$	Complementary Data Output. Connect to V _{CC} or VCSEL anode.
17	OUT	Data Output. Connect to VCSEL cathode.
18	$\overline{\text{SQEN}}$	Squelch Enable Input. Leave open to enable squelch or connect to ground to disable squelch.
19	3DB	Power-Reduction Input. Compatible with TTL. When low, 3DB activates a test mode, which reduces output power by 50%. When 3DB is high, the modulation output is normal. See the <i>Detailed Description</i> section.
21	TC1	Low-Current Temperature-Coefficient Programming Input. Sets the temperature coefficient of the bias current. Connect to GND or leave open. Do not connect to V _{CC} .
22	TC2	Low-Current Temperature-Coefficient Programming Input. Sets the temperature coefficient of the bias current. Connect to GND or leave open. Do not connect to V _{CC} .
23	TC3	Low-Current Temperature-Coefficient Programming Input. Sets the temperature coefficient of the bias current. Connect to GND or leave open. Do not connect to V _{CC} .
24	LOW1	Low-Current Programming Input. Sets the VCSEL-low (bias) current at the temperature set by the DT0 pins. Connect to GND or leave open. Do not connect to V _{CC} .
25	LOW2	Low-Current Programming Input. Sets the VCSEL-low (bias) current at the temperature set by the DT0 pins. Connect to GND or leave open. Do not connect to V _{CC} .

150Mbps Automotive VCSEL Driver

MAX3905

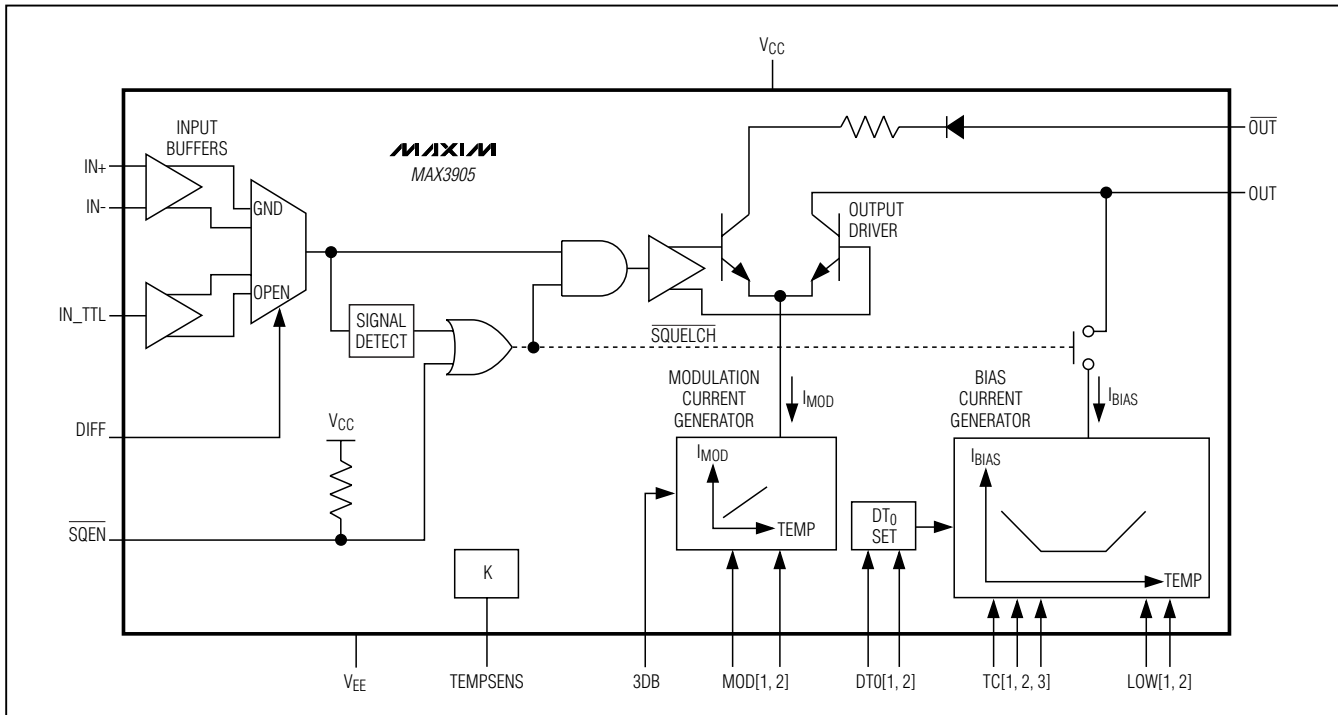

Figure 1. Functional Diagram

Detailed Description

The MAX3905 is comprised of a differential LVDS- or PECL-compatible input buffer, a TTL-compatible input buffer, signal detection, DT₀ set block, modulation-current generator, bias-current generator, and output driver (Figure 1). The device implements temperature compensation in the bias and modulation that can be customized to accommodate the variation of VCSEL properties with process and temperature. See Figure 2 and Table 1 for driver current and temperature coefficient definitions.

Input Buffers

The MAX3905 has two input buffers, one for TTL-compatible DC-coupled input data, and the other for AC-coupled, differential LVDS or PECL input data. The differential input is relatively high impedance. This allows external resistors to be configured in several ways to meet the AC- and DC-termination requirements of LVDS or PECL.

The active data input buffer is set by the DIFF input. To select the single-ended TTL input, leave DIFF open. To select the differential input, connect DIFF to ground.

When using the differential input buffer, input noise can be sufficient to prevent normal operation of the squelch

function. A small offset on the input ensures proper functioning of the squelch feature. A 1M Ω resistor from IN- to ground or VCC creates a 7mV offset.

Signal Detection and Data Squelch

When no data transitions are present at the input, the signal detection issues a squelch signal to the bias and modulation current, disabling the VCSEL output. This ensures that the receiver IC can easily detect the difference between transmitter on and transmitter off. The squelch function is enabled when SQEN is left unconnected. The squelch function can be disabled by connecting SQEN to ground.

With squelch enabled, the delay of the squelch function is suitable for use with biphase-encoded data (maximum of three consecutive identical digits (CIDs)) or 8B-/10B-encoded data (maximum five CIDs). To use the MAX3905 with scrambled data, disable the squelch function.

DT₀ Set Block

Inputs DT01 and DT02 are the 2-bit control of the center of the temperature-stable region, DT₀. The temperature set by DT0[1, 2] should correspond to the T₀ of the VCSEL. Connect DT01 or DT02 to VCC to set the bit high, or leave open to set the bit low.

The typical DT₀ can be calculated by:

150Mbps Automotive VCSEL Driver

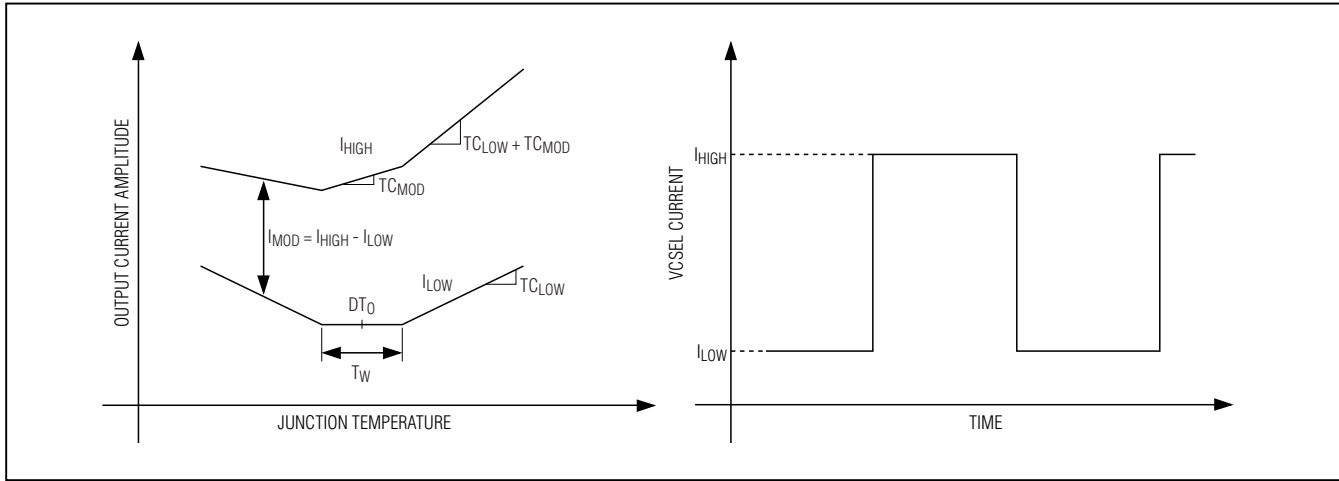

Figure 2. Driver Current and Temperature Coefficient Definitions

Table 1. Driver Current and Temperature Coefficient Definitions

PARAMETER	DESCRIPTION
I_{LOW}	Total VCSEL current when the data input is logic-low.
I_{HIGH}	Total VCSEL current when the data input is logic-high.
I_{MOD}	$I_{HIGH} - I_{LOW}$.
DT_0	The center of the temperature-stable low-current region (T_W). DT_0 roughly corresponds to T_0 of the VCSEL.
I_{DT0}	I_{LOW} at $T_J = DT_0$.
T_W	The size (in °C) of the region where no temperature coefficient is applied to I_{LOW} .
TC_{MOD}	The temperature coefficient applied to I_{MOD} .
TC_{LOW}	The temperature coefficient applied to I_{LOW} . This coefficient is negative below $DT_0 - T_W/2$ and positive above $DT_0 + T_W/2$.
I_{OFF}	Total VCSEL current while squelched.

$$DT_0 \approx [36 + 13(DT01) + 25(DT02)]^\circ C$$

where $DT0[1, 2] = 1$ when bonded to V_{CC} ; $DT0[1, 2] = 0$ when left open.

Modulation-Current Generator

The modulation-current generator provides wirebond-selectable current amplitude with temperature compensation. The temperature coefficient (TC_{MOD}) compensates for the slope-efficiency change of the VCSEL over temperature. The modulation current is set with inputs MOD1 and MOD2. Connect MOD1 or MOD2 to V_{CC} to set the bit high, and leave open to set the bit low.

The typical modulation current at +25°C can be calculated by:

$$I_{MOD} \approx [3.01 + (0.64 \times MOD1) + (1.27 \times MOD2)]mA$$

where $MOD[1, 2] = 1$ when bonded to V_{CC} ; $MOD[1, 2] = 0$ when left open.

Power Reduction

The power-reduction feature is useful for in-system test and diagnostics. When the 3DB input is low, the modulation current is reduced by 50%. When 3DB is high or V_{CC} , the modulation output is normal.

For compatibility with 5V POF transmitters, the power mode can be set by connecting a resistor from 3DB to V_{CC} . A resistor $R_{GAIN} < R_{GAINN}$ sets the normal power mode, while $R_{GAIN} > R_{GAINL}$ sets the low-power mode.

Bias-Current Generator

The bias-current generator provides a current that closely tracks the VCSEL properties with temperature. This current is summed with the modulation current at the OUT pad. The bias current at $T_J = DT_0$ is

150Mbps Automotive VCSEL Driver

MAX3905

programmed by the LOW1 and LOW2 inputs. Connect LOW1 or LOW2 to ground to set the bit high, and leave open to set the bit low. Do not connect LOW1 or LOW2 to VCC.

The typical low current at $T_J = DT_0$ can be calculated by:

$$I_{LOW} \approx [1.8 + (0.37 \times LOW1) + (0.73 \times LOW2)]mA$$

where, LOW[1, 2] = 1 when bonded to ground; LOW[1, 2] = 0 when left open.

The temperature coefficient of the bias current is programmed by the TC1, TC2, and TC3 inputs. Connect TC1, TC2, or TC3 to ground to set the bit high, and leave open to set the bit low. Do not connect TC1, TC2, or TC3 to VCC.

The typical temperature coefficient of the bias current can be calculated by:

$$TC_{LOW} \approx [16 + (5 \times TC1) + (11 \times TC2) + (16 \times TC3)]\mu A/^{\circ}C$$

where, TC[1, 2, 3] = 1 when bonded to ground; TC[1, 2, 3] = 0 when left open.

Junction-Temperature Sensing

A temperature sensor is incorporated into the MAX3905 to aid in evaluation of thermal performance. The TEMPSSENS voltage is proportional to the die junction temperature (approximately -1.39mV per °C). The temperature of the die can be estimated as:

$$T(^{\circ}C) \approx 597^{\circ}C - V_{TEMPSENS} (mV) \times \frac{0.72^{\circ}C}{1mV}$$

Output Driver

The OUT pad connects directly to the VCSEL cathode. The OUT pad must be connected to the VCSEL anode or to VCC. The minimum instantaneous voltage on the OUT pad is 0.9V.

Applications Information

Additional Design Assistance

For more information and design assistance, refer to Maxim Design Note HFDN-32.0: *Output Current Calculator for the MAX3905*.

Layout Considerations

Load inductance on OUT and OUT should be matched within 1.5nH to minimize both jitter and supply noise generation.

Wire Bonding

For high-current density and reliable operation, the MAX3905 uses gold metalization. For best results, use gold-wire ball-bonding techniques. Exercise caution when wedge bonding. Die size is 1.52mm x 1.52mm (60 mils x 60 mils), and die thickness is 300μm (12 mils). The bond-pad passivation opening is 93μm x 93μm and bond-pad metal thickness is 1.2μm. Refer to Maxim Application Note HFAN-08.0.1: *Understanding Bonding Coordinates and Physical Die Size* for additional information on bondpad coordinates. Do not attempt to bond to the laser trim target.

Laser Safety and IEC 825

Using the MAX3905 VCSEL driver alone does not ensure that a transmitter design is compliant with IEC 825. The entire transmitter circuit and component selections must be considered. Determine the level of fault tolerance required by each application, and recognize that Maxim products are not designed or authorized for use as components in systems intended for surgical implant into the body, for applications intended to support or sustain life, or for any other application where the failure of a Maxim product could create a situation where personal injury or death may occur.

150Mbps Automotive VCSEL Driver

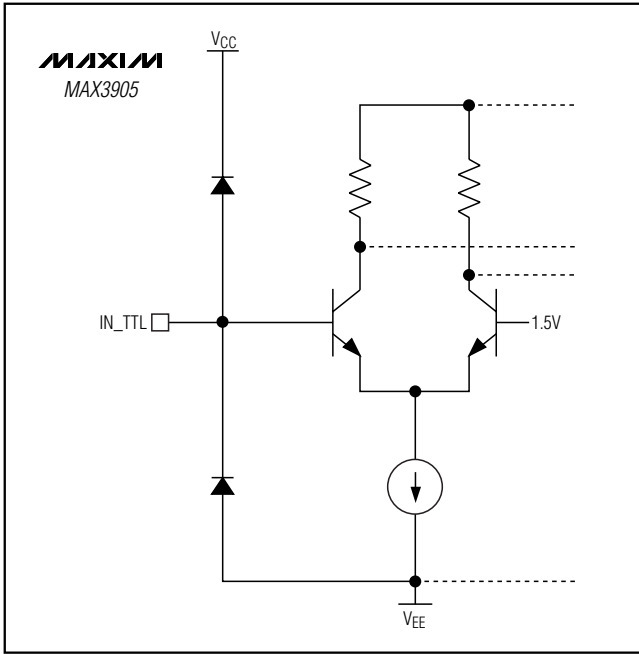

Figure 3. IN_TTL Equivalent Input Structure

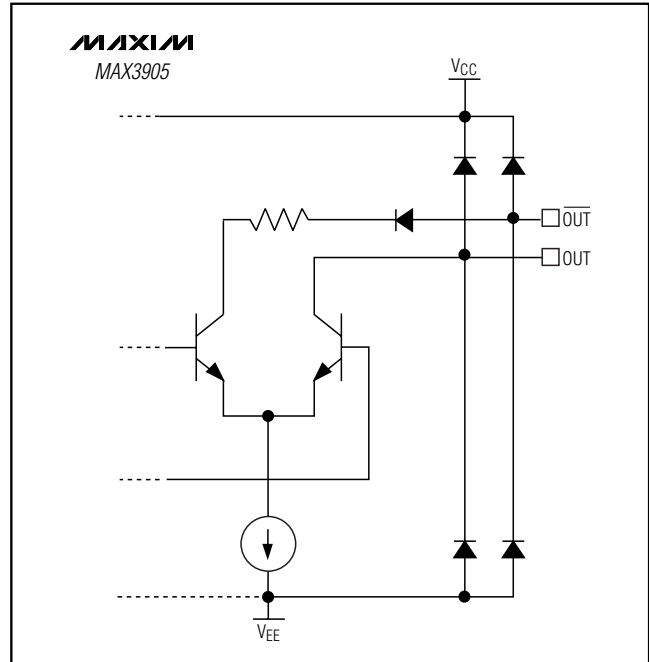

Figure 5. OUT/OUT- Equivalent Output Structure

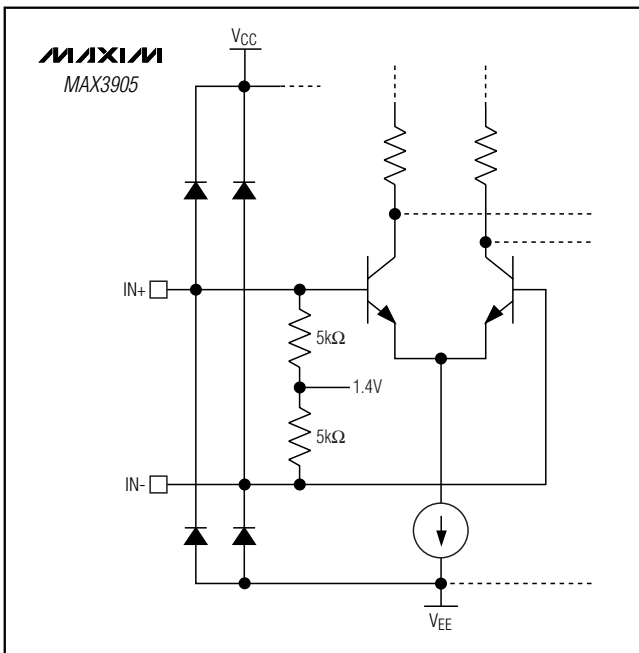

Figure 4. IN+/IN- Equivalent Input Structure

Chip Information

TRANSISTOR COUNT: 985
 PROCESS: Silicon Bipolar GST-2
 SUBSTRATE: Connected to VEE
 DIE SIZE: 1.52mm x 1.52mm (60mils x 60mils)
 DIE THICKNESS: 300μm (12mils)

150Mbps Automotive VCSEL Driver

Typical Application Circuits (continued)

MAX3905

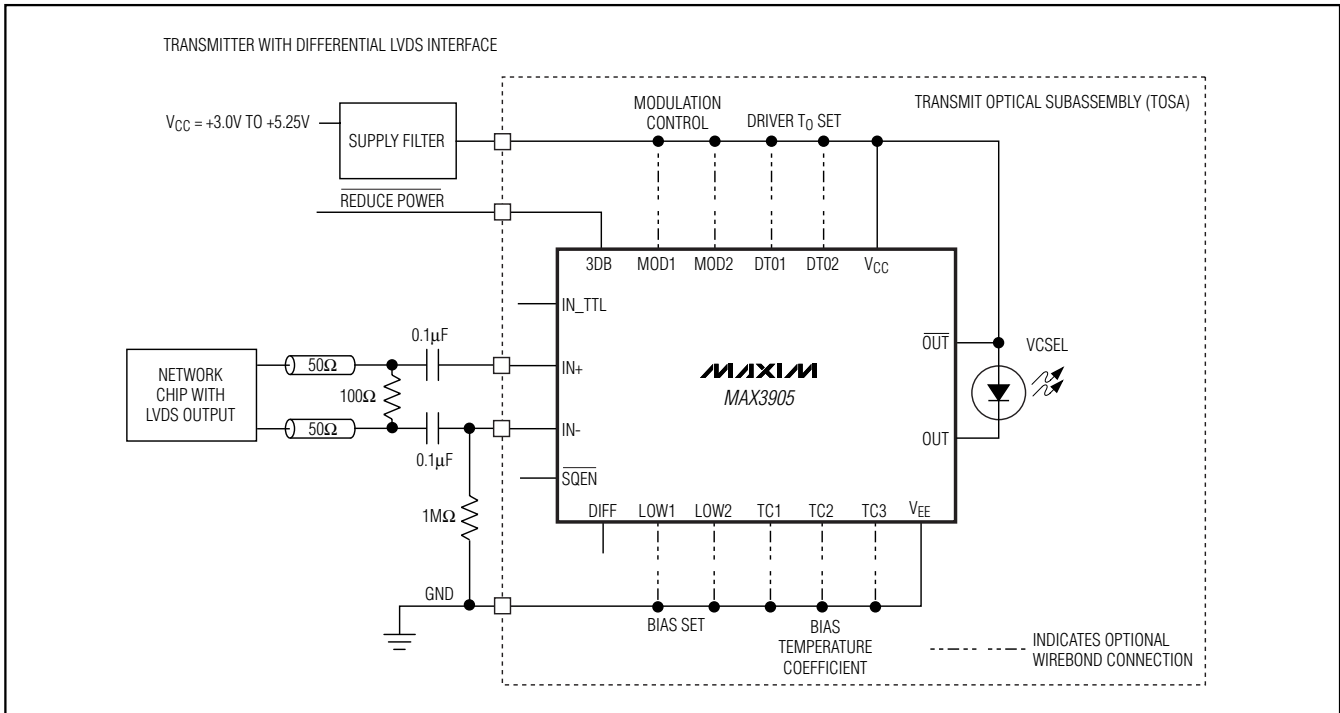
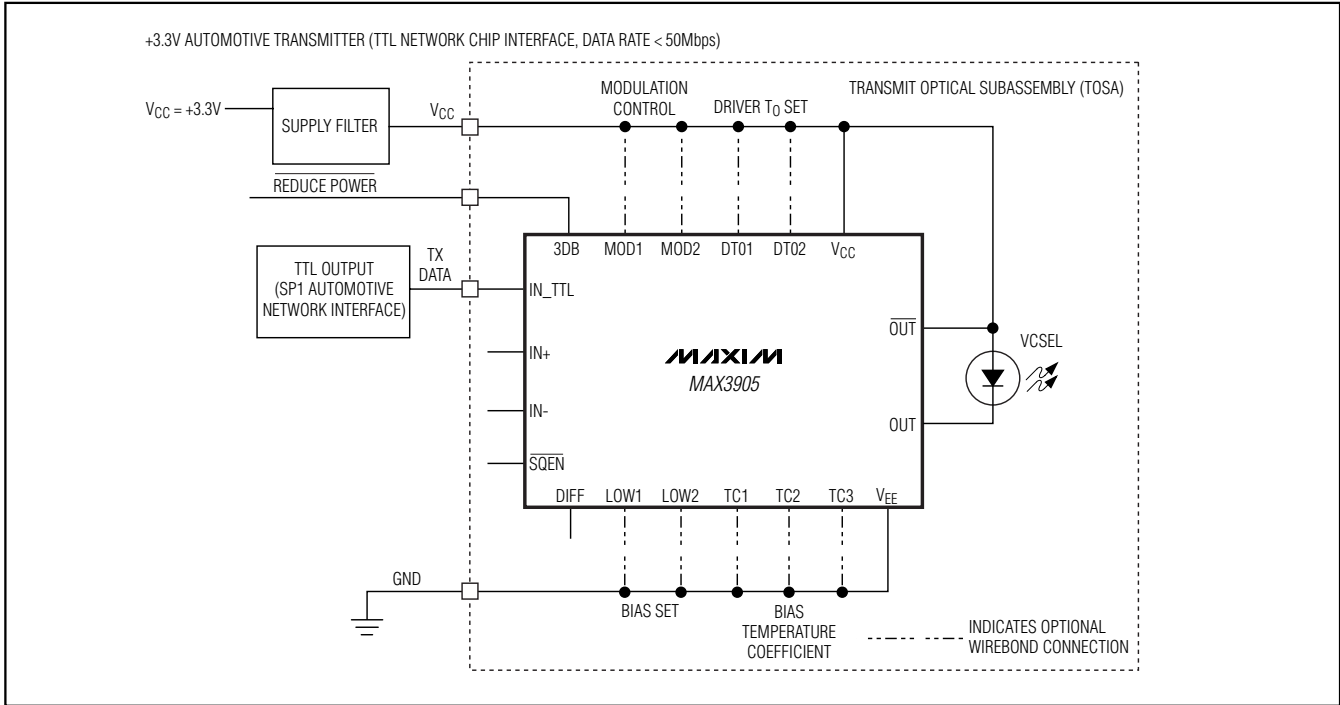

150Mbps Automotive VCSEL Driver

Typical Application Circuits (continued)

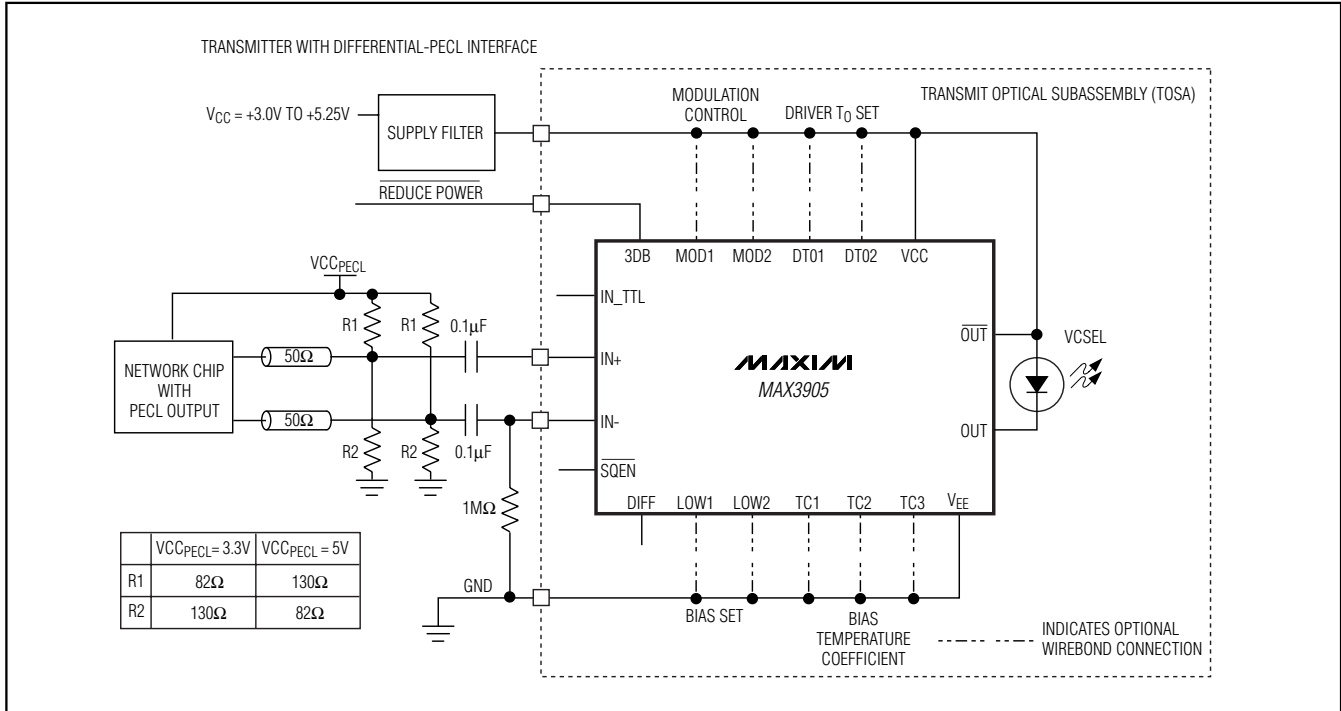

Bonding Coordinates

PAD	PAD NAME	COORDINATES (μm)	
		X	Y
1	VEE	46.6	1285.9
2	DIFF	46.6	1134.7
3	IN_TTL	46.6	983.5
4	N.C.	46.6	832.3
5	N.C.	46.6	511
6	N.C.	46.6	359.8
7	IN+	46.6	208.6
8*	TEMPSENS	46.6	46.6
9	IN-	262.6	46.6
10	VCC	791.8	46.6
11	DT01	956.5	46.6
12	DT02	1121.2	46.6
13	MOD2	1285.9	46.6

PAD	PAD NAME	COORDINATES (μm)	
		X	Y
14	MOD1	1285.9	257.2
15	VCC	1285.9	427.3
16	OUT	1285.9	594.7
17	OUT	1285.9	759.4
18	SQEN	1285.9	921.4
19	3DB	1285.9	1086.1
20	VEE	1285.9	1285.9
21	TC1	1059.1	1285.9
22	TC2	902.5	1285.9
23	TC3	745.9	1285.9
24	LOW1	589.3	1285.9
25	LOW2	432.7	1285.9
26	VEE	276.1	1285.9

Coordinates are for the center of the pad.
 Coordinate 0,0 is the lower left corner of the passivation opening for pad 8.
 *Index pad. Orient the die with this pad in the lower-left corner.

150Mbps Automotive VCSEL Driver

Chip Topography

MAX3905

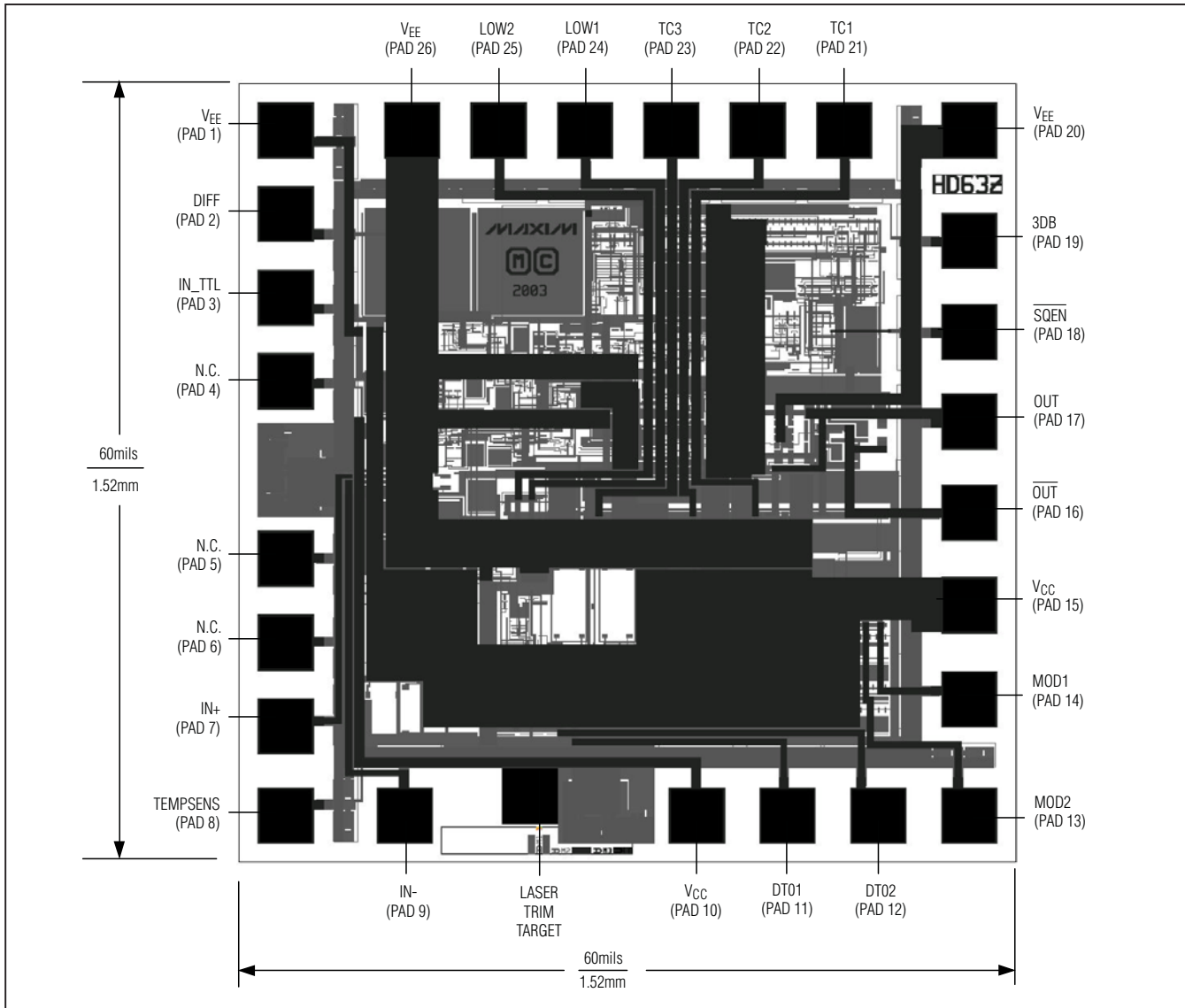

Maxim cannot assume responsibility for use of any circuitry other than circuitry entirely embodied in a Maxim product. No circuit patent licenses are implied. Maxim reserves the right to change the circuitry and specifications without notice at any time.

Maxim Integrated Products, 120 San Gabriel Drive, Sunnyvale, CA 94086 408-737-7600 13