

MAX44004

Digital Ambient Light Sensor

General Description

The MAX44004 is a wide dynamic range, low-power ambient light sensor (ALS) ideal for many light sensing applications: tablets, displays, accessories, medical devices, and light management systems.

The on-chip ambient sensor has the power to measure the exact visible light from 0.03 lux to 65,000 lux and communicate through an I²C digital communication bus. The IC has patented sensors, filters, and circuitry to mimic the human eye response. With on-chip calibration registers, it performs the same in different light conditions (i.e., fluorescent, incandescent). The interrupt pin minimizes the need of constant polling of the device, freeing up micro-controller resources for efficient communication and thus reducing overall power consumption. The part-to-part matching is optimized by proprietary Maxim process to speed up end-product development time.

The IC can operate from a V_{DD} of 1.7V to 3.6V, including both supply and I²C times. It consumes just 5μA operating current.

Applications

Tablets and Netbooks
Displays, TVs, Projectors
Digital Lighting Management
Medical Devices
Industrial Automation

Benefits and Features

- ◆ **Consumes Low Power**
 - ◇ 5μA Supply Current
 - ◇ Interrupt Pin Delivers Efficient Communication
- ◆ **High Sensitivity**
 - ◇ 0.03 Lux Sensitivity
- ◆ **Easy to Design**
 - ◇ 1.7V to 3.6V Supply Voltage
 - ◇ Tight Part-to-Part Variation
- ◆ **Reliable Light Sensing**
 - ◇ Perfect Rejection of 50Hz/60Hz Noise
 - ◇ Adjustable Visible and Infrared Sensor Gain
- ◆ **Tiny, 2mm x 2mm x 0.6mm OTDFN Package**
- ◆ **-40°C to +105°C Temperature Range**

Ordering Information appears at end of data sheet.

For related parts and recommended products to use with this part, refer to www.maxim-ic.com/MAX44004.related.

Typical Application Circuit

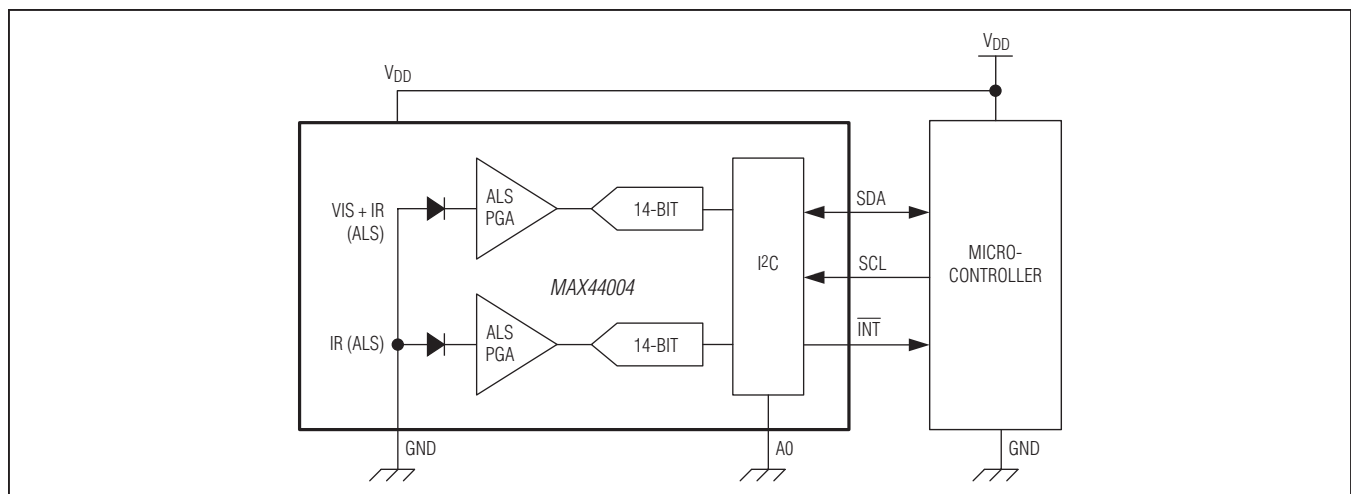

Digital Ambient Light Sensor

ABSOLUTE MAXIMUM RATINGS

All Pins to GND	-0.3V to +4.0V	Continuous Power Dissipation	
Output Short-Circuit Current Duration.....	Continuous	OTDFN (derate 11.9mW/°C above +70°C).....	953mW
Continuous Input Current into Any Terminal.....	±20mA	Operating Temperature Range.....	-40°C to +105°C
		Soldering Temperature (reflow)	+260°C

Stresses beyond those listed under "Absolute Maximum Ratings" may cause permanent damage to the device. These are stress ratings only, and functional operation of the device at these or any other conditions beyond those indicated in the operational sections of the specifications is not implied. Exposure to absolute maximum rating conditions for extended periods may affect device reliability.

ELECTRICAL CHARACTERISTICS

(V_{DD} = 1.8V, T_A = -40°C to +105°C, T_A = +25°C, unless otherwise noted.) (Note 1)

PARAMETER	SYMBOL	CONDITIONS	MIN	TYP	MAX	UNITS
AMBIENT LIGHT RECEIVER CHARACTERISTICS						
Maximum Ambient Light Sensitivity		Fluorescent light (Note 2)		0.03		Lux/ LSB
Ambient Light Saturation Level				65,535		Lux
Gain Error		Green LED 538nm response, T _A = +25°C (Note 2)			15	%
Light Source Matching		Fluorescent/incandescent light		10		%
Infrared Transmittance		850nm vs. 538nm, T _A = +25°C		0.5		%
Ultraviolet Transmittance		363nm vs. 538nm, T _A = +25°C		2		%
Dark Current Level		100ms conversion time, 0 lux, T _A = +25°C		0		Count
ADC Conversion Time		14-bit resolution, has 50Hz/60Hz rejection		100		ms
		12-bit resolution		25		
		10-bit resolution		6.25		
		8-bit resolution		1.56		
ADC Conversion Time Accuracy		T _A = +25°C			0.7	%
		T _A = -40°C to +105°C			6	
POWER SUPPLY						
Power-Supply Voltage	V _{DD}		1.7		3.6	V
Quiescent Current	I _s			5	10	μA
Software Shutdown Current	I _{SHDN}	T _A = +25°C		0.1	0.3	μA
		T _A = -40°C to +105°C			0.6	
Power-Up Time	t _{ON}			100		ms

Digital Ambient Light Sensor

ELECTRICAL CHARACTERISTICS (continued)

(V_{DD} = 1.8V, T_A = -40°C to +105°C, T_A = +25°C, unless otherwise noted.) (Note 1)

PARAMETER	SYMBOL	CONDITIONS	MIN	TYP	MAX	UNITS
DIGITAL CHARACTERISTICS—SDA, SCL, INT, A0						
Output Low Voltage SDA, INT	V _{OL}	I _{SINK} = 6mA		0.06	0.4	V
INT Leakage Current		T _A = +25°C		0.01	1000	nA
SDA, SCL, A0 Input Current				0.01	1000	nA
I ² C Input Low Voltage	V _{IL,I2C}	SDA, SCL			0.4	V
I ² C Input High Voltage	V _{IH,I2C}	SDA, SCL	1.6			V
I ² C Input Low Voltage	V _{IL,I2C}	A0			0.3	V
I ² C Input High Voltage	V _{IH,I2C}	A0	V _{DD} - 0.3			V
Input Capacitance		SDA, SCL		3		pF
I²C TIMING CHARACTERISTICS						
Serial Clock Frequency	f _{SCL}				400	kHz
Bus Free Time Between STOP and START	t _{BUF}		1.3			μs
Hold Time (Repeated) START Condition	t _{HD,STA}		0.6			μs
Low Period of the SCL Clock	t _{LOW}		1.3			μs
High Period of the SCL Clock	t _{HIGH}		0.6			μs
Setup Time for a Repeated START	t _{SU,STA}		0.6			μs
Data Hold Time	t _{HD,DAT}		0		0.9	μs
Data Setup Time	t _{SU,DAT}		100			ns
SDA Transmitting Fall Time	t _f	I _{SINK} ≤ 6mA; t _R and t _F between 0.3 × V _{DD} and 0.7 × V _{DD}		100		ns
Setup Time for STOP Condition	t _{SU,STO}		0.6			μs
Pulse Width of Suppressed Spike	t _{SP}		0		50	ns

Note 1: The device is 100% production tested at T_A = +25°C. Temperature limits are guaranteed by design.

Note 2: Guaranteed by design, green 538nm LED chosen for production so that the IC responds to 100 lux fluorescent light with 100 lux.

Digital Ambient Light Sensor

Typical Operating Characteristics

($V_{DD} = 1.8V$, $T_A = -40^{\circ}C$ to $+85^{\circ}C$, unless otherwise noted. All devices are 100% production tested at $T_A = +25^{\circ}C$. Temperature limits are guaranteed by design.)

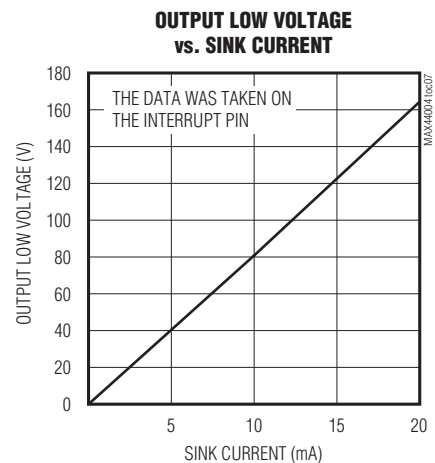
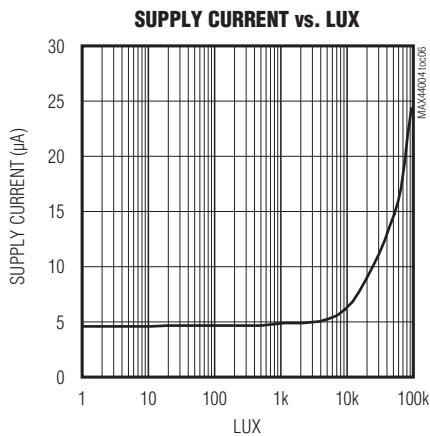
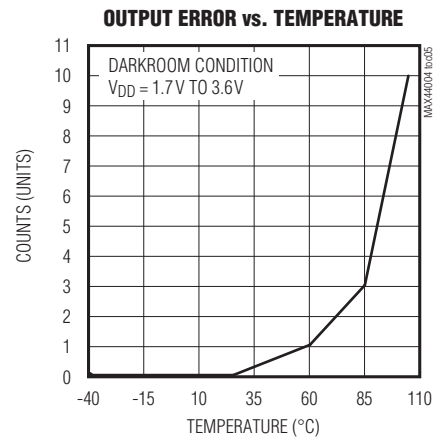
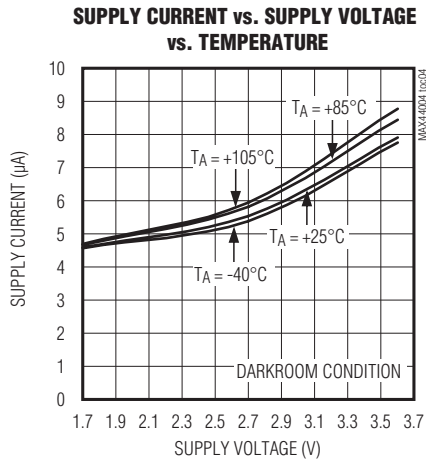
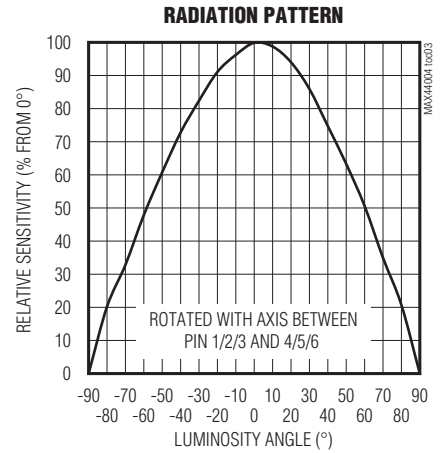
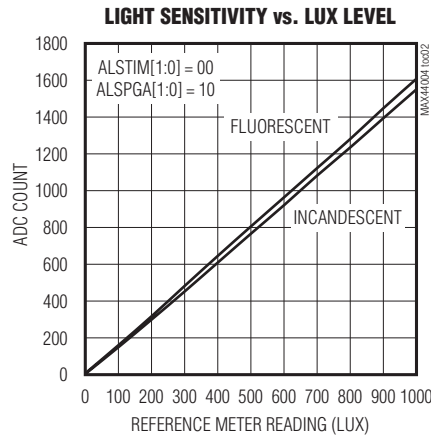
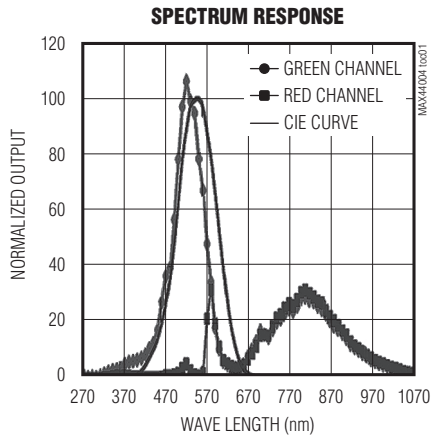

MAX44004

Digital Ambient Light Sensor

Pin Configuration

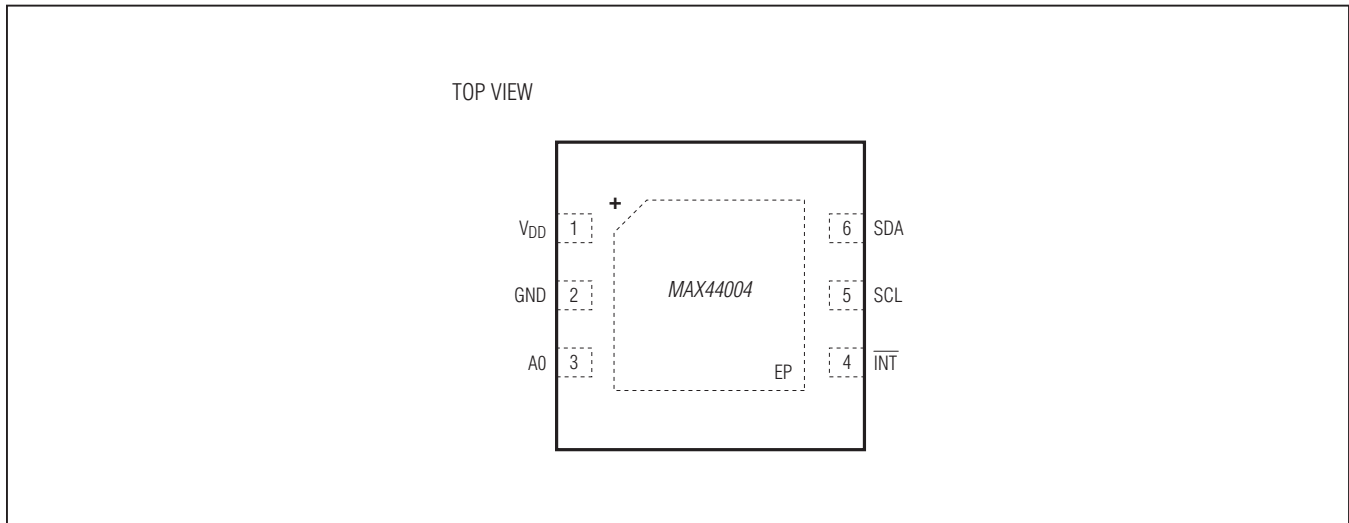

Pin Description

PIN	NAME	FUNCTION
1	V _{DD}	Power Supply
2	GND	Ground
3	A0	Address Select
4	$\overline{\text{INT}}$	Active-Low Interrupt
5	SCL	I ² C Clock
6	SDA	I ² C Data
—	EP	Exposed Pad. EP is internally connected to GND. EP must be connected to GND.

Digital Ambient Light Sensor

Detailed Description

The MAX44004 is a wide-dynamic-range ALS. The die is placed inside an optically transparent (ODFN) package. A photodiode array inside the device converts the light to a current, which is then processed by low-power circuitry into a digital value stream. The data is then stored in an output register that is read by an I²C interface.

Two types of photodiodes are used in the device: a green photodiode and an infrared photodiode. Ambient light sensing is accomplished by subtracting the green ALS photodiode signal and the infrared ALS photodiode signals, after applying appropriate gains.

The photodiodes are connected to two ADCs. The user can choose to view either just the green ALS signal, or just the infrared ALS signal, or the difference of the green and infrared ALS photodiodes.

Two key features of the device's analog design are its low-power design and interrupt pin operation.

The device can operate from a V_{DD} of 1.7V to 3.6V and consumes just 5 μ A current. An on-chip programmable interrupt function eliminates the need to continually poll the device for data, resulting in a significant power saving.

Ambient-Light Sensing

Ambient-light sensors are designed to detect brightness in the same way as human eyes do. To achieve this, the light sensor needs to have a spectral sensitivity that is identical to the photopic curve of the human eye (Figure 1). Small deviations from the photopic curve can affect perceived brightness by ambient light sensors to be wildly different. However, there are practical

difficulties in trying to reproduce the ideal photopic curve in a small cost-efficient package. The devices instead use two types of photodiodes (green and infrared) that have different spectral sensitivities—each of which is amplified and subtracted on-chip with suitable gain coefficients so that the most extreme light sources (fluorescent and incandescent) are well matched to a commercial illuminance lux meter.

The photopic curve represents a typical human eye's sensitivity to different wavelengths of light. As can be seen in Figures 1 and 2, its peak sensitivity is at 555nm (green). The human eye is insensitive to infrared (> 700nm) and ultraviolet (< 400nm) radiation.

Variation between light sources can extend beyond the visible spectral range—fluorescent and incandescent light sources, for example—with similar visible brightness (lux) and can have substantially different IR radiation content (since the human eye is blind to it). Since this infrared radiation can be picked up by silicon photodiodes, differences in light spectra can affect brightness measurement of light sensors. For example, light sources with high IR content such as an incandescent bulb or sunlight could suggest a much brighter environment than our eyes would perceive them to be. Other light sources, such as fluorescent and LED-based systems, have very little infrared content. The devices incorporate on-chip compensation techniques to minimize these effects and still output an accurate lux response in a variety of lighting conditions.

On-chip, user-programmable green channel and IR channel gain trim registers allow the light-sensor response to be tailored to the application, such as when the light sensor is placed under a dark or colored glass.

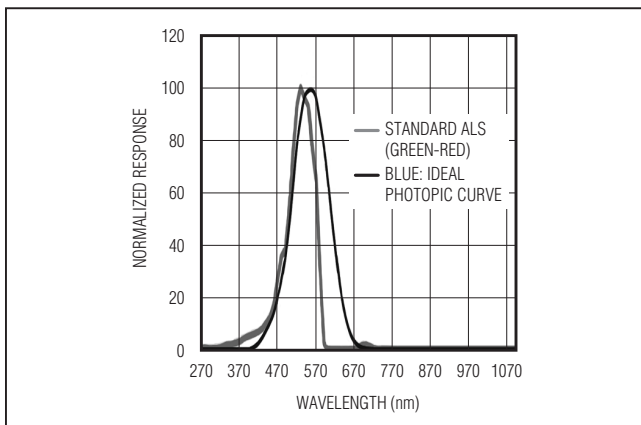

Figure 1. MAX44004 Spectral Response Compared to Ideal Photopic Curve

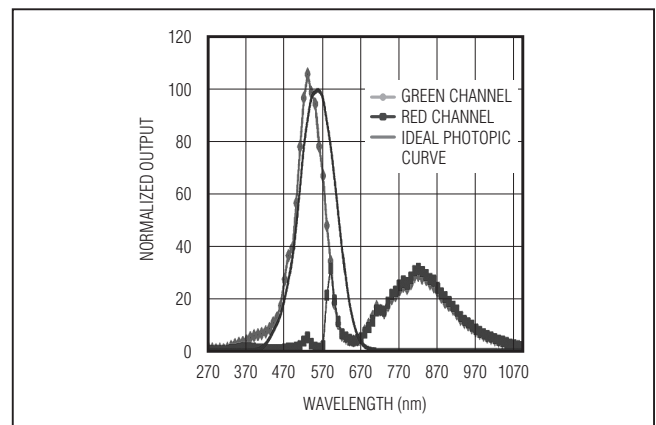

Figure 2. Green Channel and IR Channel Response at Identical Gains on a Typical MAX44004

Digital Ambient Light Sensor

Register Description

Table 1 is the register description.

The individual register bits are explained in Table 2. Default power-up bit states are highlighted in bold.

Interrupt Status 0x00

The PWRON bit in the Status register 0x00, if set, indicates that a power-on-reset (POR) condition has occurred, and any user-programmed thresholds may not

be valid anymore. The ALSINTS bit in the Status register 0x00 indicates that an ambient-light-interrupt condition has occurred. If any of these bits are set to 1, the INT pin is pulled low and is asserted. See Table 2.

Reading the Interrupt Status register clears the PWRON and ALSINTS bits if set, AND deasserts the $\overline{\text{INT}}$ pin (i.e., INT is pulled high by the off-chip pullup resistor). The ALSINTS bit is disabled and set to 0 if the ALSINTE interrupt enable bit in Register 0x01 is set to 0.

Table 1. Component List

REGISTER	BIT7	BIT6	BIT5	BIT4	BIT3	BIT2	BIT1	BIT0	REGISTER ADDRESS	POWER-ON RESET STATE	R/W	
STATUS												
Interrupt Status						PWRON		ALSINTS	0x00	0x04	R	
CONFIGURATION												
Main Configuration			TRIM		MODE[1:0]			ALSINTE	0x01	0x24	R/W	
Receiver Configuration					ALSTIM[1:0]		ALSPGA[1:0]		0x02	0x00	R/W	
ADC DATA												
ADC High Byte—ALS		OFL	ALSDATA[13:8]							0x04	0x00	R
ADC Low Byte—ALS	ALSDATA[7:0]								0x05	0x00	R	
THRESHOLD SET												
ALS Upper Threshold—High Byte			UPTHR [13:8]							0x06	0x00	R/W
ALS Upper Threshold—Low Byte	UPTHR[7:0]								0x07	0x00	R/W	
ALS Lower Threshold—High Byte			LOTHR[13:8]							0x08	0x00	R/W
ALS Lower Threshold—Low Byte	LOTHR [7:0]								0x09	0x00	R/W	
Threshold Persist Timer								ALSPST[1:0]	0x0A	0x00	R/W	
Digital Gain Trim of Green Channel	TRIM_GAIN_GREEN [6:0]							TRIM_GAIN_IR [0]	0x0F	0x80	R/TW	
Digital Gain Trim of Infrared Channel	TRIM_GAIN_IR [8:1]								0x10	0x80	R/TW	

Table 2. Interrupt Status

REGISTER	BIT7	BIT6	BIT5	BIT4	BIT3	BIT2	BIT1	BIT0	REGISTER ADDRESS	POWER-ON RESET STATE	R/W
Interrupt Status						PWRON		ALSINTS	0x00	0x04	R

Digital Ambient Light Sensor

Ambient Interrupt Status (ALSINTS)

The individual ALSINTS register bits are explained in [Table 3](#).

Power-On Reset Status (PWRON)

The individual Power-On Reset Status (PWRON) register bits are explained in [Table 4](#).

Main Configuration 0x01

The individual Main Configuration register bits are explained in [Table 5](#).

This register is used to set the operating mode of the IC and to enable interrupt operation of the device.

TRIM

The individual TRIM register bits are explained in [Table 6](#).

The individual register bits are explained in [Table 7](#).

Table 3. Ambient Interrupt Status (ALSINTS)

BIT0	OPERATION
0	No interrupt trigger event has occurred.
1	The ambient light intensity has traversed outside the designated window limits defined by the Threshold registers for greater than persist timer count ALSPST[1:0], or an overflow condition in the ambient-light readings has occurred. This bit also causes the $\overline{\text{INT}}$ pin to be pulled low. Once set, the only way to clear this bit is to read this register or to set the ALSINTE bit in register 0x01 to 0.

Table 4. Power-On Reset Status (PWRON)

BIT2	OPERATION
0	No interrupt trigger event has occurred.
1	The part went through a power-up event, either because the part was turned on, or because there was a power-supply voltage glitch. All interrupt threshold settings in the registers have been reset to a default state, and should be examined. A 1 on this bit also causes the $\overline{\text{INT}}$ pin to be pulled low. Once this bit is set, the only way to clear this bit is to read this register.

Table 5. Main Configuration (0x01)

REGISTER	BIT7	BIT6	BIT5	BIT4	BIT3	BIT2	BIT1	BIT0	REGISTER ADDRESS	POWER-ON RESET STATE	R/W
Main Configuration			TRIM		MODE[1:0]			ALSINTE	0x01	0x24	R/W

Table 6. TRIM

BIT 5	OPERATION
0	Use bytes written to TRIM_GAIN_GREEN[6:0] and TRIM_GAIN_IR[8:0] registers to set the fine-trim gain of the green and IR gain channels.
1	Use factory-programmed gains for green and IR channels. Ignore bytes written to TRIM_GAIN_GREEN[6:0] and TRIM_GAIN_IR[8:0] registers.

Digital Ambient Light Sensor

Ambient Interrupt Enable (ALSINTE)

The individual Ambient Interrupt Enable bits are explained in [Table 8](#).

Receive Configuration 0x02

[Table 9](#) explains Receive Configuration 0x02.

This register sets the ADC integration time and front-end photodiode circuitry sensitivity (gain). The ADC integration time also controls the bit resolution of measurements.

ADC conversions of MSB are made first (the device needs longer conversion times for higher resolution measurements, i.e., LSBs). Use of lower PGA gains helps expand the full-scale range of the ADC at the expense of per-LSB sensitivity.

Ambient ADC Conversion Time (ALSTIM)

The 2 bits ALSTIM [1:0] set the integration time for ALS ADC conversion, as shown in [Table 10](#).

Table 7. Individual Register Bits

MODE[1:0]	OPERATING MODE	OPERATION
00	Shutdown	Analog circuits are shut down, but digital register retains values.
01	ALS G-IR	Standard ALS mode—stores difference between green and infrared channel readings.
10	ALS G	ALS green channel only.
11	ALS IR	Infrared channel only.

Note: 100–111 are reserved. Do not use.

Table 8. Ambient Interrupt Enable

BIT0	OPERATION
0	The ALSINTS bit remains unasserted; ALS channel readings are not compared with interrupt thresholds.
1	Detection of an ambient-light interrupt event triggers a hardware interrupt (INT pin is pulled low) and sets the ALSINTS bit (register 0x00, B0). ALS channel readings are compared with ALS interrupt threshold settings and ALS persist timer.

Table 9. Receive Configuration (0x02)

REGISTER	BIT7	BIT6	BIT5	BIT4	BIT3	BIT2	BIT1	BIT0	REGISTER ADDRESS	POWER-ON RESET STATE	R/W
Receive Configuration					ALSTIM[1:0]		ALSINTE		0x02	0x00	R/W

Table 10. ALSTIM Integration Time for ADC Conversions

ALSTIM[1:0]	INTEGRATION TIME (ms)	FULL-SCALE ADC COUNTS	BIT RESOLUTION	RELATIVE LSB SIZE
00	100	16,384	14	1x
01	25	4096	12	4x
10	6.25	1024	10	16x
11	1.5625	256	8	64x

Digital Ambient Light Sensor

Ambient Light Measurement Gain (ALSPGA)

The 2 bits ALSPGA [1:0] set the gain of the ambient-light sensing measurement according to [Table 11](#).

ALS Data Register (0x04, 0x05)

The 2 bytes here (ALSDATA[13:0]) hold the results of ALS signal conversion. The resolution and bit length of the result is controlled by the value of the ALSTIM[1:0] and ALSPGA[1:0] bits. The result is always right justified in the two registers, and the unused high bits are zero. See [Table 12](#).

OFL indicates an overflow condition on the ALS channel. If this occurs, set the ALS range (ALSPGA[1:0]) to a higher range (lower sensitivity). If the OFL bit is set to 1 (there is an overflow condition), and the ALSINTE bit is

set to 1 (enabled), then the ALSINTS bit is set to 1 and the $\overline{\text{INT}}$ pin is pulled low.

The data in this register could be either the green channel, infrared channel, or ALS readings (green channel, infrared channel readings), depending on the mode selected by the user.

Internal update of these two registers is disabled during I²C read operations to ensure proper data handoff between the ADC and the I²C registers. Update of the I²C registers is resumed once the master sends a STOP command. Therefore, when reading the 2 bytes of this register, the master should NOT send a STOP command between the 2-byte reads. Instead, a Repeated START command should be used. The exact read sequence using the Repeated START command is shown in the *I²C Serial Interface* section.

Table 11. Ambient Light Measurement Gain (ALSPGA)

ALSPGA[1:0]	LUX/LSB	RELATIVE LSB SIZE
00	0.03125	1x
01	0.125	4x
10	0.5	16x
11	4	128x

Table 12. ALS Data Register (0x04, 0x05)

REGISTER	BIT7	BIT6	BIT5	BIT4	BIT3	BIT2	BIT1	BIT0	REGISTER ADDRESS	POWER-ON RESET STATE	R/W
ADC High Byte—ALS		OFL	ALSDATA[13:8]						0x04	0x00	R
ADC Low Byte—ALS	ALSDATA[7:0]								0x05	0x00	R

Table 13. ALS Interrupt Threshold Registers (0x06–0x09)

REGISTER	BIT7	BIT6	BIT5	BIT4	BIT3	BIT2	BIT1	BIT0	REGISTER ADDRESS	POWER-ON RESET STATE	R/W
ALS Upper Threshold—High Byte			UPTHR [13:8]						0x06	0x00	R/W
ALS Upper Threshold—Low Byte	UPTHR [7:0]								0x07	0x00	R/W
ALS Lower Threshold—High Byte			LOTHR[13:8]						0x08	0x00	R/W
ALS Lower Threshold—Low Byte	LOTHR [7:0]								0x09	0x00	R/W

Digital Ambient Light Sensor

ALS Interrupt Threshold Registers (0x06-0x09)

ALS Interrupt Threshold registers (0x06-0x09) are explained in [Table 13](#).

The ALS upper threshold and ALS lower threshold (UPTHR[13:0] and LOTHR[13:0]) set the window limits that are used to trigger an ALS interrupt. It is important to set these values according to the selected bit resolution/integration time chosen for the ALS measurement based on the ALSTIM[1:0] and ALSPGA[1:0] settings. The upper 2 bits are always ignored. If the INTE bit is set, and the lux level is greater or lower than the respective thresholds for a period greater than that defined by the ALSPST persist time, the INTS bit in the Status register are set and the INT pin is pulled low.

Threshold Persist Timer Register (0x0A)

The MAX44004 incorporates a persist function that allows users to set the number of consecutive triggers before interrupt. The Threshold Persist Timer register is explained in [Table 14](#).

ALSPST[1:0] sets one of four persist values that controls how readily the interrupt logic reacts to a detected event.

This feature is useful in reducing false or nuisance interrupts due to optical noise/minor disturbances. See [Table 15](#).

When ALSPST[1:0] is set to 00, and the ALSINTE bit is set to 1, the first time an ALS interrupt event is detected, the ALSINTE interrupt bit is set and the INT pin goes low. If ALSPST[1:0] is set to 01, then four consecutive interrupt events must be detected on four consecutive measurement cycles. Similarly, if ALSPST[1:0] is set to 10 or 11, then 8 or 16 consecutive interrupts must be detected before the INT pin is pulled low. If there is an intervening measurement cycle where no interrupt is detected, then the count is reset to zero.

Digital Gain Trim Registers (0x0F, 0x10)

Digital gain trim registers are described in [Table 16](#).

TRIM_GAIN_GREEN [6:0] is used to modify the gain of the green channel.

TRIM_GAIN_IR [8:0] is used to modify the gain of the IR channel.

To tell the part to use the values written to this register, set the TRIMB bit to 0 in the Main Configuration register after writing new values to these registers.

Table 14. Threshold Persist Timer Register (0x0A)

REGISTER	BIT7	BIT6	BIT5	BIT4	BIT3	BIT2	BIT1	BIT0	REGISTER ADDRESS	POWER-ON RESET STATE	R/W
Threshold Persist Timer							ALSPST[1:0]		0x0A	0x00	R/W

Table 15. APSPT [1:0]

ALSPST[1:0]	NO. OF CONSECUTIVE TRIGGERS BEFORE AN INTERRUPT
00	1
01	2
10	4
11	16

Table 16. Digital Gain Trim Registers (0x0F, 0x10)

REGISTER	BIT7	BIT6	BIT5	BIT4	BIT3	BIT2	BIT1	BIT0	REGISTER ADDRESS	POWER-ON RESET STATE	R/W
Digital Gain Trim of Green Channel	TRIM_GAIN_GREEN [6:0]							TRIM_GAIN_IR	0x0F	0x80	R/TW
Digital Gain Trim of Infrared Channel	TRIM_GAIN_IR [8:1]								0x10	0x80	R/TW

Note 1: Values read from the Trim_Gain registers are the complement of the written value. This is true for reading both the factory-programmed values and the customer-programmed values.

Digital Ambient Light Sensor

Applications Information

Ambient-Sensing Applications

Typical applications involve placing the device behind a glass with a small semitransparent window above it. Use the photodiode-sensitive area as shown in [Figure 3](#) to properly position the window above the part.

The part comes equipped with internal gain trim registers for the green and IR ALS photodiodes. By suitably choosing the gains for these channels, accurate ambient light readings can be generated in all lighting conditions regardless of the type of glass/ink under which the part is used. This is especially useful for black glass applications where, for cosmetic reasons, the part is placed behind a black film to hide its presence, and this film has the peculiar property of attenuating most ambient light, but passing through IR radiation.

In standard ALS mode, the green channel and infrared channel readings are internally subtracted. Since one is observing only the difference is observed in two separate ADC measurements, wrong readings can be obtained if one of the channels becomes saturated, while the other channel continues to rise. Since the green photodiode also picks up a lot of the infrared signal, this saturation can occur earlier than before the maximum expected

full-scale lux, depending on lighting conditions. For example, under incandescent light, there is a lot more infrared optical power than in the visible spectral range. In these situations, the green channel can saturate much earlier than 511 lux in the most sensitive range. To assist the user in detecting these conditions, an OFL bit is provided that alerts the user of an overrange condition. This bit also triggers an ALS interrupt if it has been enabled.

Typical Operating Sequence

The typical operating sequence for the master to communicate to the device on first power-up is shown below:

- 1) Setup:
 - a) Read the Interrupt Status register (0x00) to confirm only the PWRON bit is set. This also clears a hardware interrupt.
 - b) Set Threshold and Persist Timer registers (registers 0x06–0x0C).
 - c) Write 0x00 to the Receiver Configuration register (register 0x02) to set the ALS sensor in the highest gain setting, and in 14-bit modes of operation.
 - d) Write 0x05 to the Main Configuration register (register 0x01) to set the part in ALS mode and to enable ALS interrupt.
 - e) Set new green channel gains and IR channel gains, if necessary, to customize ALS operation for application conditions. Ensure the TRIM bit is set to 0 when not using default factory-trim settings.
- 2) Wait for interrupt.
- 3) On interrupt:
 - a) Read the Interrupt Status register (0x00) to confirm the device to be the source of interrupt, and to check for type of interrupt. This should clear the hardware interrupt on the part, if set.
 - b) If an ALS interrupt has occurred, read ALS ADC registers (register 0x04–0x05) to confirm if data is valid (i.e., OFL = 0), and take appropriate action (e.g., set new backlight strength). Set new ALS thresholds, if necessary.
 - c) Return to Step 2.

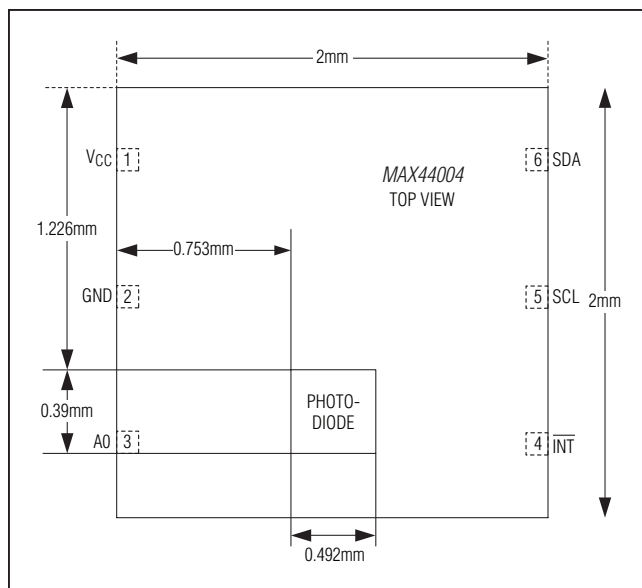

Figure 3. MAX44004 Photodiode Location

Digital Ambient Light Sensor

I²C Serial Interface

The device features an I²C/SMBus™-compatible, 2-wire serial interface consisting of a serial data line (SDA) and a serial clock line (SCL). SDA and SCL facilitate communication between the device and the master at clock rates up to 400kHz. Figure 4 shows the 2-wire interface timing diagram. The master generates SCL and initiates data transfer on the bus. A master device writes data to the device by transmitting the proper slave address followed by the register address and then the data word. Each transmit sequence is framed by a START (S) or Repeated START (Sr) condition and a STOP (P) condition. Each word transmitted to the device is 8 bits long and is followed by an acknowledge clock pulse. A master reading data from the device transmits the proper slave address followed by a series of nine SCL pulses. The IC transmits data on SDA in sync with the master-generated SCL pulses. The master acknowledges receipt of each byte of data. Each read sequence is framed by a START

or Repeated START condition, a not acknowledge, and a STOP condition. SDA operates as both an input and an open-drain output. A pullup resistor, typically greater than 500Ω, is required on the SDA bus. SCL operates as only an input. A pullup resistor, typically greater than 500Ω, is required on SCL if there are multiple masters on the bus, or if the master in a single-master system has an open-drain SCL output. Series resistors in line with SDA and SCL are optional. Series resistors protect the digital inputs of the device from high-voltage spikes on the bus lines, and minimize crosstalk and undershoot of the bus signal.

Bit Transfer

One data bit is transferred during each SCL cycle. The data on SDA must remain stable during the high period of the SCL pulse. Changes in SDA while SCL is high are control signals. See the *START and STOP Conditions* section. SDA and SCL idle high when the I²C bus is not busy.

Table 17. Slave Address

A0	SLAVE ADDRESS
GND	0x94
V _{DD}	0x96

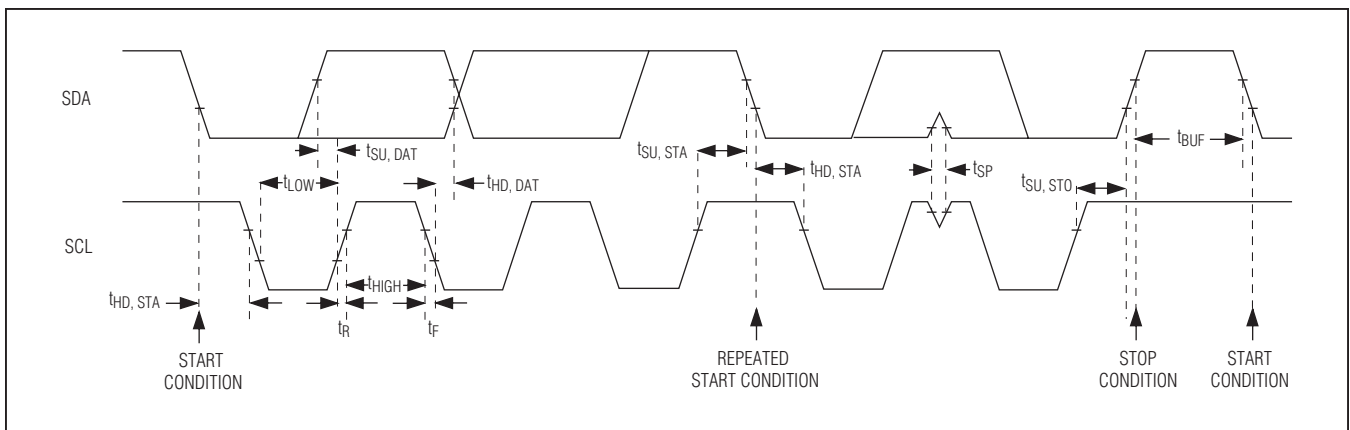

Figure 4. 2-Wire Interface Timing Diagram

SMBus is a trademark of Motorola Corp.

Digital Ambient Light Sensor

START and STOP Conditions

SDA and SCL idle high when the bus is not in use. A master initiates communication by issuing a START condition. A START condition is a high-to-low transition on SDA with SCL high. A STOP condition is a low-to-high transition on SDA while SCL is high (Figure 5). A START condition from the master signals the beginning of a transmission to the device. The master terminates transmission, and frees the bus by issuing a STOP condition. The bus remains active if a Repeated START condition is generated instead of a STOP condition.

Early STOP Conditions

The device recognizes a STOP condition at any point during data transmission, except if the STOP condition occurs in the same high pulse as a START condition. For proper operation, do not send a STOP condition during the same SCL high pulse as the START condition.

Acknowledge

The acknowledge bit (ACK) is a clocked 9th bit that the device uses to handshake receipt of each byte of data when in write mode (Figure 6). The device pulls down SDA during the entire master-generated 9th clock pulse if the previous byte is successfully received. Monitoring

ACK allows for detection of unsuccessful data transfers. An unsuccessful data transfer occurs if a receiving device is busy or if a system fault has occurred. In the event of an unsuccessful data transfer, the bus master may retry communication. The master pulls down SDA during the 9th clock cycle to acknowledge receipt of data when the device is in read mode. An acknowledge is sent by the master after each read byte to allow data transfer to continue. A not acknowledge is sent when the master reads the final byte of data from the device, followed by a STOP condition.

Write Data Format

A write to the device includes transmission of a START condition, the slave address with the R/W bit set to 0, 1 byte of data to configure the internal register address pointer, 1 or more bytes of data, and a STOP condition. Figure 7 illustrates the proper frame format for writing 1 byte of data to the device. Figure 8 illustrates the frame format for writing n bytes of data to the device.

The slave address with the R/W bit set to 0 indicates that the master intends to write data to the device. The device acknowledges receipt of the address byte during the master-generated 9th SCL pulse.

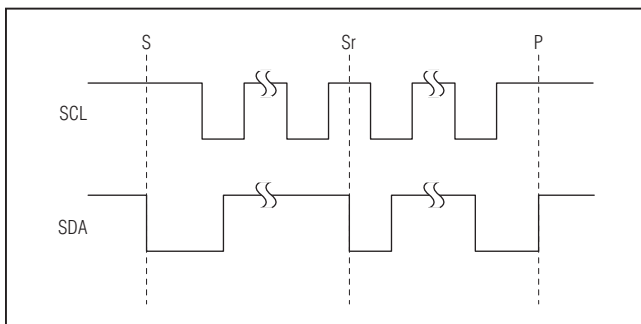

Figure 5. START, STOP, and Repeated START Conditions

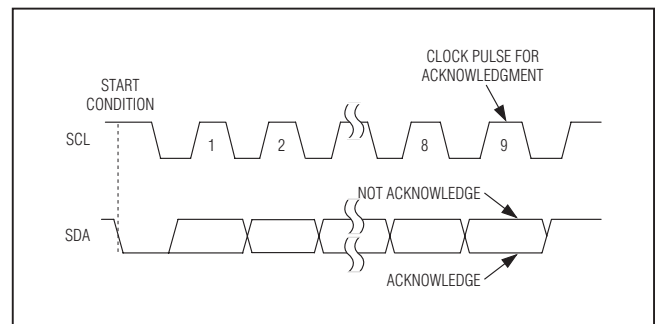

Figure 6. Acknowledge

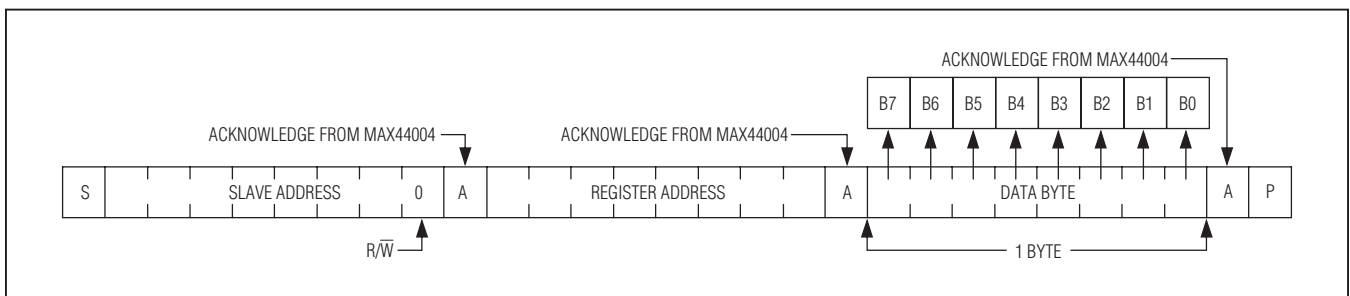

Figure 7. Writing 1 Byte of Data to the MAX44004

Digital Ambient Light Sensor

The second byte transmitted from the master configures the device's internal register address pointer. The pointer tells the device where to write the next byte of data. An acknowledge pulse is sent by the device upon receipt of the address pointer data.

The third byte sent to the device contains the data that is written to the chosen register. An acknowledge pulse from the device signals receipt of the data byte.

Read Data Format

Send the slave address with the R/W bit set to 1 to initiate a read operation. The device acknowledges receipt of its slave address by pulling SDA low during the 9th SCL clock pulse. A start command followed by a read command resets the address pointer to register 0x00.

The first byte transmitted from the device is the contents of register 0x00. Transmitted data is valid on the rising edge of the master-generated serial clock (SCL). The address pointer does not autoincrement after each read data byte. A STOP condition can be issued after any number of read data bytes. If a STOP condition is issued followed by another read operation, the first data byte to be read is

from register 0x00 and subsequent reads autoincrement the address pointer until the next STOP condition.

The address pointer can be preset to a specific register before a read command is issued. The master presets the address pointer by first sending the device's slave address with the R/W bit set to 0 followed by the register address. A Repeated START condition is then sent, followed by the slave address with the R/W bit set to 1. The device transmits the contents of the specified register. Attempting to read from register addresses higher than 0xFF results in repeated reads of 0xFF. Note that 0xF6 to 0xFF are reserved registers.

The master acknowledges receipt of each read byte during the acknowledge clock pulse. The master must acknowledge all correctly received bytes except the last byte. The final byte must be followed by a not acknowledge from the master and then a STOP condition. [Figure 8](#) illustrates the frame format for reading 1 byte from the device. [Figure 9](#) illustrates the frame format for reading two registers consecutively without a STOP condition in between reads.

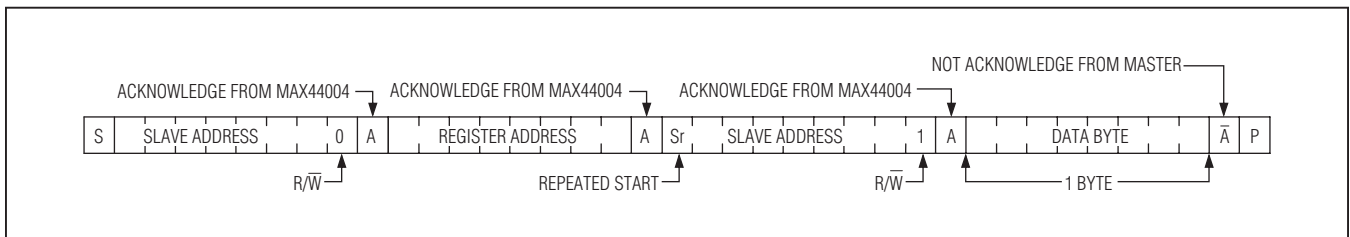

Figure 8. Reading 1 Byte of Data from the MAX44004

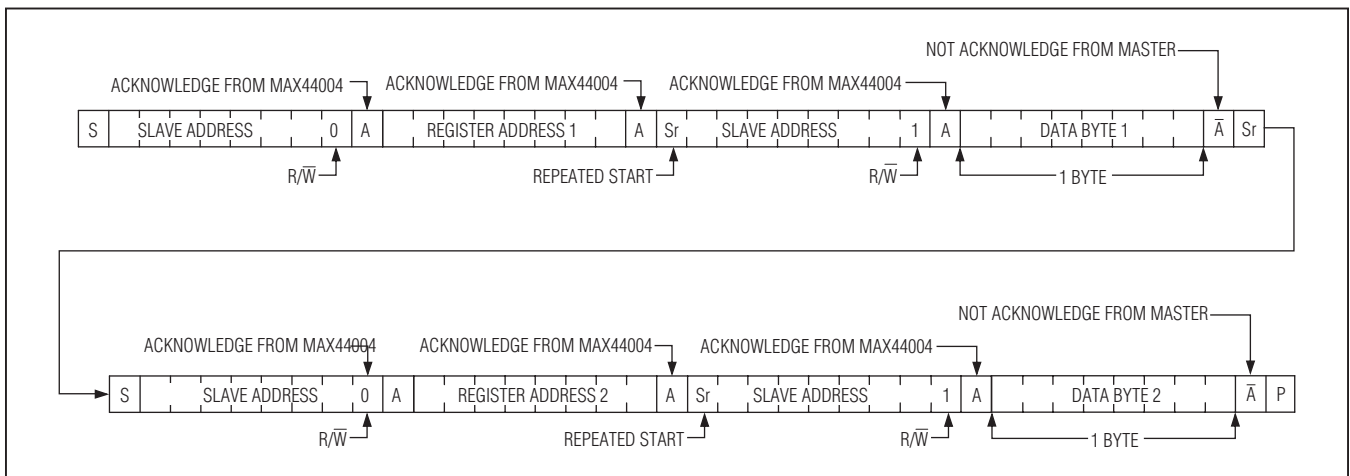

Figure 9. Reading Two Registers Consecutively Without a STOP Condition in Between Reads

MAX44004

Digital Ambient Light Sensor

Ordering Information

PART	TEMP RANGE	PIN-PACKAGE
MAX44004GDT+	-40°C to +105°C	6 OTDFN

+Denotes a lead(Pb)-free/RoHS-compliant package.

Package Information

For the latest package outline information and land patterns (footprints), go to www.maxim-ic.com/packages. Note that a "+", "#", or "-" in the package code indicates RoHS status only. Package drawings may show a different suffix character, but the drawing pertains to the package regardless of RoHS status.

PACKAGE TYPE	PACKAGE CODE	OUTLINE NO.	LAND PATTERN NO.
6 OTDFN	D622N+2	21-0490	90-0344

MAX44004

Digital Ambient Light Sensor

Revision History

REVISION NUMBER	REVISION DATE	DESCRIPTION	PAGES CHANGED
0	5/12	Initial release	—

Maxim cannot assume responsibility for use of any circuitry other than circuitry entirely embodied in a Maxim product. No circuit patent licenses are implied. Maxim reserves the right to change the circuitry and specifications without notice at any time.

Maxim Integrated Products, 160 Rio Robles Drive, San Jose, CA 95134 408-601-1000 _____ 17