

Click [here](#) to ask about the production status of specific part numbers.

## MAX5171 Breakout Board

## 14-Bit Force/Sense DAC

### General Description

Digital-to-analog converters (DACs) provide accurate output voltages for actuation and control in many electronic applications such as industrial, medical and RF systems. The MAX5171 is a highly accurate, 14-bit voltage output DAC. Development with DACs involves expertise in analog systems, power supplies, digital interfaces, and firmware. Now, accelerate the development process using the MAX5171 breakout board.

This breakout board provides rapid prototyping and development with the MAX5171 (a 14-bit, voltage-output DAC). It interfaces to any Arduino™-compatible or Mbed-compatible platform system with expansion ports configurable for SPI communication. Additionally, the MAX5171 breakout board works with systems that have a Pmod™ connection, a 2x6 right-angle header at board edge (compatible with Digilentinc.com Pmod interface spec) interface type 2A (expanded SPI) on 2x6 header at board edge. The breakout board also comes with schematics, design files, and firmware for immediate use and forking to future projects.

The board directly interfaces to SPI with logic levels in the range 2.7V to 5.5V. (**Note:** The MAX5171 is specified for 4.5V to 5.5V operation, and the pin-compatible MAX5173 is specified for 2.7V to 3.6V operation.)

The board comes installed with MAX5171AEEE+ installed. Example firmware is provided for Arduino and Mbed system boards.

Tested with:

- MAX32625MBED#  
<https://os.mbed.com/platforms/MAX32625MBED/>
- MAX32600MBED#  
<https://os.mbed.com/platforms/MAX32600MBED/>
- STM32F446 Nucleo-64  
<https://os.mbed.com/platforms/ST-Nucleo-F446RE/>
- Arduino UNO (rev 3)  
<https://store.arduino.cc/usa/arduino-uno-rev3/>
- Adafruit Metro 328 Arduino compatible (USB micro B)  
<https://www.adafruit.com/product/50>
- Arduino Pro Mini 3.3V/8MHz  
<https://store.arduino.cc/usa/arduino-pro-mini/>

[Ordering Information](#) appears at end of data sheet.

### MAX5171 Breakout Board Photo

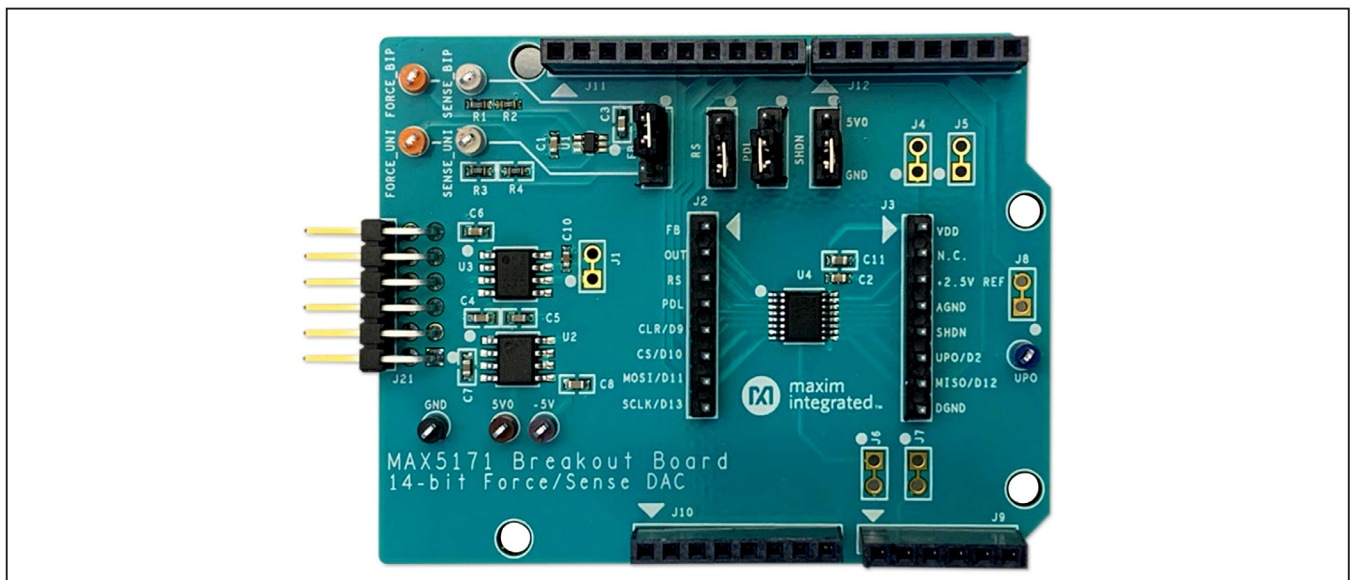

Pmod is a trademark of Digilent, Inc.

Arduino is a trademark of Arduino AG.

Arm is a registered trademark and Mbed is a trademark of Arm Limited (or its subsidiaries) in the US and/or elsewhere.



MAX5171 Breakout Board Pinout

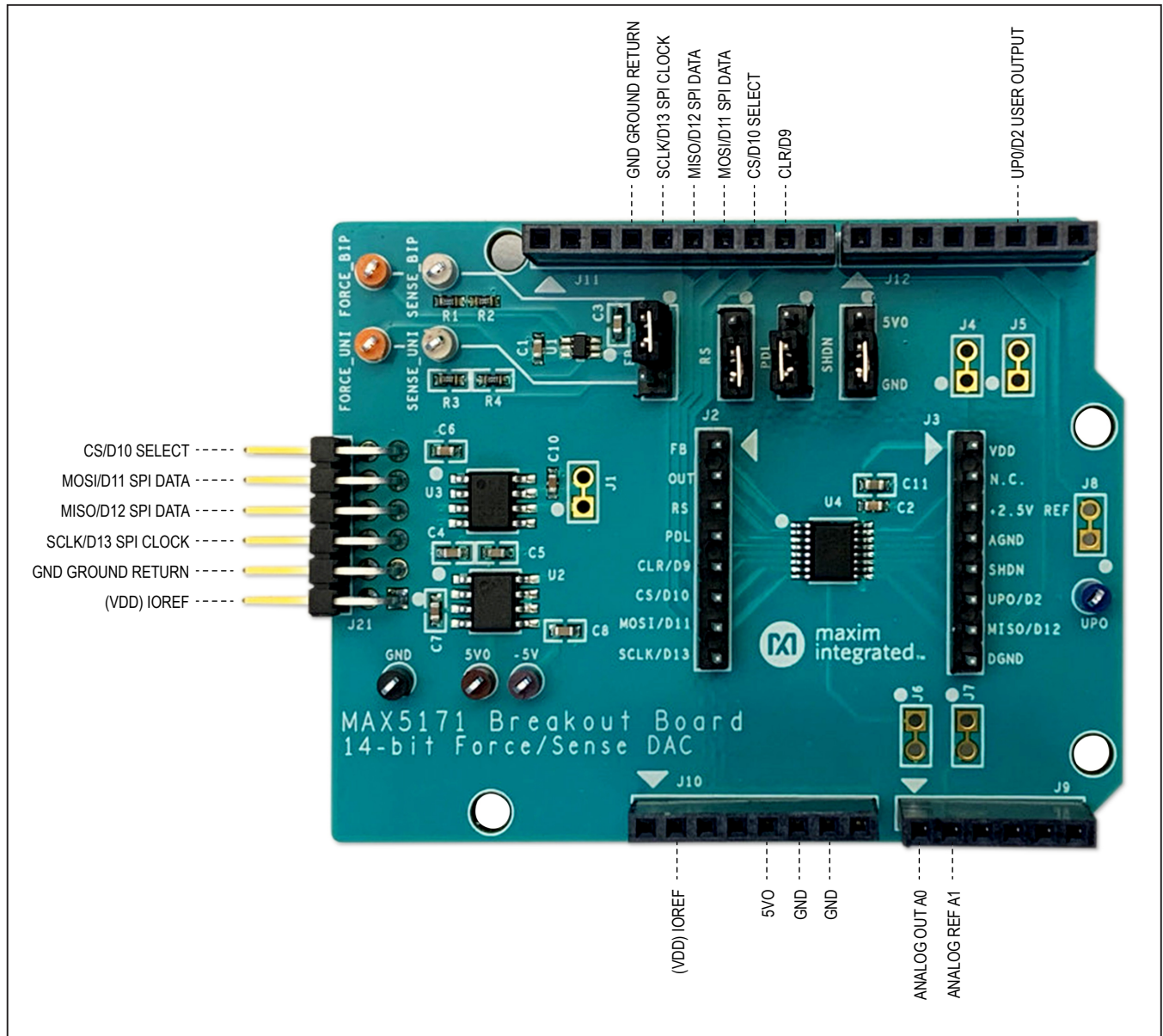

## Quick Start

### Required Equipment

- MAX5171BOB# breakout board
- Appropriate Mbed or Arduino board
- The following procedures describe the Quick Start process with the MAX32625MBED# and the Arduino UNO
- Computer with USB and web access
- A serial terminal emulator software such as teraterm, realterm, picocom, minicom, or equivalent

The following procedures describe the Quick Start process with the MAX32625MBED# and the Arduino. The MAX5171 breakout board has been tested on the platform boards listed above.

There are two example programs for each platform:

- The Simplified Hello World program is a small example program that can be changed by modifying the Hello\_MAX5171.cpp source code and repeating the compile-build-upload cycle, providing straightforward code for easy adoption.
- The Serial Tester program is an interactive, menu-driven test program that is controlled through a serial communications port, using a terminal emulator, supporting quick discovery and evaluation of device features for testing functionality.

### Procedure for Mbed: Simplified Hello World

The Simplified Hello World program is a small example program that can be changed by modifying the Hello\_MAX5171.cpp source code and repeating the compile-build-upload cycle, providing straightforward code for easy adoption.

The MAX5171 breakout board is fully assembled and tested.

The first time the board is used, the MAX5171 breakout board firmware must be loaded into the MAX32625MBED, or equivalent platform board. This firmware is stored on the MAX32625MBED board and remains after the board is powered off.

When the board is plugged into USB the first time, the computer may need about a minute to install its device drivers.

Follow the steps below to verify board operation:

- 1) Connect the MAX5171 breakout board to the MAX32625MBED or equivalent Mbed platform board using the standard pinout.

- 2) Connect a USB cable from the computer to the MAX32625MBED board HDK USB port. (Windows® may require some time to install its device driver.) Expect the system to automatically mount the board as a new USB drive named MBED, DAPLINK, or something similar. This is a special-purpose drive: firmware is loaded into the board by copying the compiled binary into the board's drive. Do not write any other files to this drive.
- 3) Open the board's USB device folder and double click on its MBED.HTML file. On the board page, click **Add** to the Mbed compiler. This adds the Mbed board to the online compiler as a compilation target. See <https://os.mbed.com/docs/mbed-os/v5.13/quick-start/index.html> for more detailed instructions on using the online compiler.
- 4) In a web browser, navigate to [https://os.mbed.com/teams/MaximIntegrated/code/MAX5171BOB\\_14bit\\_Remote\\_Sense\\_SPI\\_DAC/](https://os.mbed.com/teams/MaximIntegrated/code/MAX5171BOB_14bit_Remote_Sense_SPI_DAC/) and click **Import into Compiler**. The Mbed online IDE window opens and prompts to **Import** the program. Click the **Import** button to complete the import.
- 5) Compile the program. When complete, the online Mbed IDE downloads the firmware file to your local **Downloads** folder.
- 6) Locate the newly built firmware file **MAX5171BOB\_14bit\_Remote\_Sense\_SPI\_DAC.MAX32625MBED.bin** and copy the file to the board's Mbed drive. (The names might not match exactly if using a platform other than the MAX32625MBED, or if there is already a file with that name.) If a warning dialog appears asking to move this file without its properties, click **Yes**. After file copying is complete, press and release the board's **Reset** button to start the firmware. Use a DVM to measure the voltages on the MAX5171 breakout board.
- 7) Change the program behavior by modifying the Hello\_MAX5171.cpp source code and repeating the compile-build-upload cycle from step 4.

Discard local changes and reset to the latest published firmware version as follows: Bring up the project **Revision** tab and right-click on the line that says default tip. In the popup context menu, select **Switch working copy to this revision....** A warning indicating that there are uncommitted local changes in the working tree appears. Click **Discard**, and all of the local files are reset to the published version.

*Windows is the registered trademarks and registered service mark of Microsoft Corporation.*

### Procedure for Mbed: Serial Tester

The Serial Tester program is an interactive, menu-driven test program that is controlled through a serial communications port, using a terminal emulator, supporting quick discovery, and evaluation of device features for testing functionality.

The MAX5171 breakout board is fully assembled and tested.

The first time the board is used, the MAX5171 breakout board firmware must be loaded into the MAX32625MBED, or equivalent platform board. This firmware is stored on the MAX32625MBED board and remains after the board is powered off.

The serial tester firmware uses a USB serial port to communicate.

When the board is plugged into the USB port for the first time, the computer may need about a minute to install its device drivers.

Follow the steps below to verify board operation:

- 1) Connect the MAX5171 breakout board to the MAX32625MBED or equivalent Mbed platform board using the standard pinout.
- 2) Connect a USB cable from computer to MAX32625MBED board HDK USB port. (Windows may require some time to install its device driver.) Expect the system to automatically mount the board as a new USB drive named MBED, DAPLINK, or something similar. This is a special-purpose drive: firmware is loaded into the board by copying the compiled binary into the board's drive. Do not write any other files to this drive.
- 3) Open the board's USB device folder and double click on its MBED.HTML file. On the board page, click **Add** to the Mbed compiler. This adds the Mbed board to the online compiler as a compilation target. See <https://os.mbed.com/docs/mbed-os/v5.13/quick-start/index.html> for more detailed instructions on using the online compiler.
- 4) In a web browser, navigate to [https://os.mbed.com/teams/MaximIntegrated/code/MAX5171BOB\\_Serial\\_Tester/](https://os.mbed.com/teams/MaximIntegrated/code/MAX5171BOB_Serial_Tester/) and click **Import into Compiler**. The Mbed online IDE window opens and prompts to import program. Click the **Import** button to complete the import.
- 5) Compile the program. When complete, the online Mbed IDE downloads the firmware file to your local **Downloads** folder.
- 6) Locate the newly built firmware file **MAX5171BOB\_Serial\_Tester.MAX32625MBED.bin** and copy the file to the board's Mbed drive. (The names might not match exactly if using a platform other than MAX32625MBED, or if there is already a file with that name.) If a warning dialog appears asking to move this file without its properties, click **Yes**.
- 7) Connect another, or the existing USB cable from computer to the MAX32625MBED board DEV USB port. Expect the LEDs in the lower-right corner to flash briefly and then remain illuminated.
- 8) Locate the newly installed USB serial device COM port. Use a serial terminal emulator (such as teraterm, realterm, picocom, minicom, or equivalent). Baud rate is 9600.

### Procedure for Arduino: Simplified Hello World

The Simplified Hello World program is a small example program that can be changed by modifying the Hello\_MAX5171.cpp source code and repeating the compile-build-upload cycle, providing straightforward code for easy adoption.

The MAX5171 breakout board is fully assembled and tested.

Note if used with classic Arduino UNO, which has full-sized USB type B connector, ensure that the shield of the USB connector does not come into contact with the underside of the breakout board/Arduino shield.

The first time the board is used, the MAX5171 breakout board firmware must be loaded into the Arduino board. This firmware is stored on the Arduino board and remains after the board is powered off.

The firmware uses a USB serial port to communicate.

When the board is plugged into the USB port for the first time, the computer may need about a minute to install its device drivers.

Follow these steps to verify board operation:

- 1) Connect the MAX5171 breakout board to the Arduino board using the standard pinout.
- 2) Connect a USB cable from the computer to the Arduino board USB port. (Windows may require some time to install its device driver.)
- 3) In a web browser, navigate to <https://create.arduino.cc/editor/whismanoid/10d1ee33-1599-4c0a-aeec-6d4be4091929/preview> and click **Add to my Sketchbook**.

*Windows is the registered trademarks and registered service mark of Microsoft Corporation.*

- 4) Connect the USB cable to the Arduino hardware. If this is the first time using Arduino Create online, a prompted to install Arduino Create Agent to connect with the hardware.
- 5) Compile the program using the **Upload** and **Save** button.
- 6) Change the program behavior by modifying the Hello\_MAX5171.cpp source code and repeating the compile-build-upload cycle.

### Procedure for Arduino: Serial Tester

The Serial Tester program is an interactive, menu-driven test program that is controlled through a serial communications port, using a terminal emulator, supporting quick discovery and evaluation of device features for testing functionality.

The MAX5171 breakout board is fully assembled and tested.

Note if used with classic Arduino UNO, which has full-sized USB type B connector, ensure that the shield of the USB connector does not come into contact with the underside of the breakout board/Arduino shield.

The first time the board is used, the MAX5171 breakout board firmware must be loaded into the Arduino board. This firmware is stored on the Arduino board and remains after the board is powered off.

The firmware uses a USB serial port to communicate.

When the board is plugged into USB the first time, the computer may need about a minute to install its device drivers.

Follow these steps to verify board operation:

- 1) Connect the MAX5171 breakout board to the Arduino board using the standard pinout.
- 2) Connect a USB cable from computer to Arduino board USB port. (Windows may require some time to install its device driver.)
- 3) In a web browser, navigate to <https://create.arduino.cc/editor/whismanoid/8ed60c93-04d2-4b08-b2ab-7289dade5f8c/preview> and click **Add to my Sketchbook**.
- 4) Connect the USB cable to the Arduino hardware. If this is the first time using Arduino Create online, you may be prompted to install Arduino Create Agent to connect with the hardware.
- 5) Compile the program with the **Upload and Save** button.
- 6) Locate the newly installed USB serial device COM port, and use a serial terminal emulator (such as teraterm, realterm, picocom, minicom, or equivalent). Baud rate is 9600.

### Sending Commands with a Serial Console

A serial terminal emulator software (such as teraterm, realterm, putty, picocom, minicom, or equivalent) must be installed to communicate with the example firmware. Various terminal programs connect in various ways and have different user interfaces, but they all share a common set of basic features:

- Connecting to a specific serial port device by name, such as COM4 or /dev/ttyACM0
- Settings such as baud rate 9600, 8 bits/no parity/1 stop bit, no flow control
- Typing with the keyboard transmits to the firmware through the serial port
- Messages received from the firmware are displayed on the screen
- A special keyboard command or menu item exits the terminal program

See <https://os.mbed.com/handbook/Terminals> for more details.

More resources:

- <https://learn.sparkfun.com/tutorials/terminal-basics/tera-term-windows>
- <https://learn.sparkfun.com/tutorials/terminal-basics/real-term-windows>
- <https://learn.sparkfun.com/tutorials/terminal-basics/yat---yet-another-terminal-windows>
- <https://learn.sparkfun.com/tutorials/terminal-basics/coolterm-windows-mac-linux>
- <https://learn.adafruit.com/windows-tools-for-the-electrical-engineer/serial-terminal>
- <https://www.putty.org/>

In Windows, install a terminal emulator such as teraterm, realterm, or putty. Find the serial port name and COM port number in **Control Panel | View devices and printers**. The Mbed board appears as a **USB Serial Device** or **mbed Serial Port**. Refer to <https://os.mbed.com/handbook/Windows-serial-configuration> and <https://os.mbed.com/docs/mbed-os/v5.11/tutorials/windows-serial-driver.html> for troubleshooting. Start the terminal emulator and use its menu to connect to the serial port that belongs to the board. Pressing **Enter** displays the firmware's banner message. See the [Example Serial Console Session](#) section.

In linux, install a terminal emulator such as minicom or picocom. For example, under Debian or Ubuntu linux, use

```
sudo apt-get install picocom
```

In linux (Debian), find the serial port name as follows:

```
# with the board not connected, get list of tty device names
ls -l /dev/tty* >dev_tty_baseline
# now connect the device to USB and find the new tty device name (such as /dev/ttyACM0)
ls -l /dev/tty* | diff dev_tty_baseline -
```

The picocom terminal emulator runs from the tty console. The tty device name must be given on the command line when starting picocom. See man picocom for more details.

```
picocom /dev/ttyACM0 --baud 9600
```

Pressing **Enter** displays the firmware's banner message (see example session). Pressing **Ctrl+A** and then **Ctrl+X** exits picocom.

### Example Serial Console Session

The firmware uses a USB serial port to communicate. Typing `?` prints a menu of supported device commands.

```
<PRE>
Main menu MAX5171 14-bit Force/Sense DAC [serial]
? -- help
MAX5171 > # Example for MAX5171 Breakout Board
Main menu MAX5171 14-bit Force/Sense DAC [serial]
? -- help
MAX5171 > ?

Main menu MAX5171 14-bit Force/Sense DAC [serial]
? -- help
# -- lines beginning with # are comments
. -- SelfTest
%Hn {pin: 0 1 2 3 4 5 6 7 8 9 14 15 16 17} -- High Output
%Ln {pin: 0 1 2 3 4 5 6 7 8 9 14 15 16 17} -- Low Output
%?n {pin: 0 1 2 3 4 5 6 7 8 9 14 15 16 17} -- Input
%A -- analogRead
%SC SCLK=24000000=24.000MHz CPOL=0 CPHA=0 -- SPI config
%SD -- SPI diagnostic messages hide
%SW mosi,mosi,...mosi -- SPI write hex bytes
A-Z,a-z,0-9 -- reserved for application use
! -- Init
0 code=? -- CODE
4 code=? -- CODE_LOAD
8 -- LOAD
c -- NOP
d -- SHUTDOWN
e0 -- UPO_LOW
e8 -- UPO_HIGH
f0 -- MODE1_DOUT_SCLK_RISING_EDGE
f8 -- MODE0_DOUT_SCLK_FALLING_EDGE
@ -- print MAX5171 configuration
MAX5171 > # send 4 CODE_LOAD code=0x3fff expect AIN0(AIN4)=full scale 2.5V

Main menu MAX5171 14-bit Force/Sense DAC [serial]
? -- help
```

```

MAX5171 > 4 code=0x3fff
CODE_LOAD dacCodeLsbs=16383
      SPI MOSI-> 0x7F 0xFF MISO<- 0x00 0x00 =1
MAX5171 > # send 4 CODE_LOAD code=0x0000 expect AIN0(AIN4)=zero scale 0V
Main menu MAX5171 14-bit Force/Sense DAC [serial]
? -- help
MAX5171 > 4 code=0x0000
CODE_LOAD dacCodeLsbs=0
      SPI MOSI-> 0x40 0x00 MISO<- 0x7F 0xFF =1
MAX5171 > # send 4 CODE_LOAD code=0x1fff expect AIN0(AIN4)=mid scale 1.25V
Main menu MAX5171 14-bit Force/Sense DAC [serial]
? -- help
MAX5171 > 4 code=0x1fff
CODE_LOAD dacCodeLsbs=8191
      SPI MOSI-> 0x5F 0xFF MISO<- 0x40 0x00 =1
MAX5171 > # send e8 UPO_HIGH expect input D2=1
Main menu MAX5171 14-bit Force/Sense DAC [serial]
? -- help
MAX5171 > e8
UPO_HIGH
      SPI MOSI-> 0xE8 0x00 MISO<- 0x5F 0xFF =1
MAX5171 > # send e0 UPO_LOW expect input D2=0
Main menu MAX5171 14-bit Force/Sense DAC [serial]
? -- help
MAX5171 > e0
UPO_LOW
      SPI MOSI-> 0xE0 0x00 MISO<- 0xE8 0x00 =1
MAX5171 > .
selfTest()
      VRef = 2.500 MAX5171 14-bit LSB = 0.00015V
+PASS MAX5171.DACCodeOfVoltage(2.4998V) expect 16383
+PASS MAX5171.DACCodeOfVoltage(2.4997V) expect 16382
+PASS MAX5171.DACCodeOfVoltage(2.4995V) expect 16381
+PASS MAX5171.DACCodeOfVoltage(2.4994V) expect 16380
+PASS MAX5171.DACCodeOfVoltage(1.2502V) expect 8193
+PASS MAX5171.DACCodeOfVoltage(1.2500V) expect 8192
+PASS MAX5171.DACCodeOfVoltage(1.2498V) expect 8191
+PASS MAX5171.DACCodeOfVoltage(1.2497V) expect 8190
+PASS MAX5171.DACCodeOfVoltage(0.0005V) expect 3
+PASS MAX5171.DACCodeOfVoltage(0.0003V) expect 2
+PASS MAX5171.DACCodeOfVoltage(0.0002V) expect 1
+PASS MAX5171.DACCodeOfVoltage(0.0000V) expect 0
      VRef = 2.500 MAX5171 14-bit LSB = 0.00015V
+PASS MAX5171.voltageOfCode(0x3fff) expect 2.499847
+PASS MAX5171.voltageOfCode(0x3ffe) expect 2.499695

```

```

+PASS MAX5171.voltageOfCode(0x3ffd) expect 2.499542
+PASS MAX5171.voltageOfCode(0x3ffc) expect 2.499390
+PASS MAX5171.voltageOfCode(0x2001) expect 1.250153
+PASS MAX5171.voltageOfCode(0x2000) expect 1.250000
+PASS MAX5171.voltageOfCode(0x1fff) expect 1.249847
+PASS MAX5171.voltageOfCode(0x1ffe) expect 1.249695
+PASS MAX5171.voltageOfCode(0x3) expect 0.000458
+PASS MAX5171.voltageOfCode(0x2) expect 0.000305
+PASS MAX5171.voltageOfCode(0x1) expect 0.000153
+PASS MAX5171.voltageOfCode(0x0) expect 0.000000
+PASS MAX5171.vRef expect 2.500000
    100.0% of full scale REF(2.50V) = 2.50V Jumper FB=1-2
    SPI MOSI-> 0x7F 0xFF MISO<- 0xE0 0x00
+PASS AIN0 = 41.740% = 2.504V expect 2.500000 +/- 0.050000
    0.0% of full scale REF(2.50V) = 0.000V
    SPI MOSI-> 0x40 0x00 MISO<- 0x7F 0xFF
+PASS AIN0 = 0.391% = 0.023V expect 0.000000 +/- 0.050000
    50.0% of full scale REF(2.50V) = 1.25V
    SPI MOSI-> 0x5F 0xFF MISO<- 0x40 0x00
+PASS AIN0 = 21.017% = 1.261V expect 1.250000 +/- 0.050000
    SPI MOSI-> 0xE8 0x00 MISO<- 0x5F 0xFF
+PASS UPO signal=1 UPO_pin is high after MAX5171 UPO_HIGH command
    SPI MOSI-> 0xE0 0x00 MISO<- 0xE8 0x00
!WARN expected UPO signal=0 UPO_pin is low after MAX5171 UPO_LOW command, but got actual
UPO=1, missing UPO connections?
    SPI MOSI-> 0xE8 0x00 MISO<- 0xE0 0x00
+PASS UPO signal=1 UPO_pin is high after MAX5171 UPO_HIGH command
Summary: 30 PASS 0 FAIL
MAX5171 >
</PRE>

```

## Detailed Description of Hardware

The MAX5171 is a 14-bit, voltage-output DAC with SPI Interface. The MAX6126 provides a 2.5V reference voltage. For bipolar operation, the MAX889 charge pump generates a -5V power supply rail to drive the MAX44260 operational amplifier. Jumper FB selects unipolar or bipolar output configuration. When configured for unipolar output, analog output is driven from the FORCE\_UNI test point and sensed by the SENSE\_UNI test point, with closed-loop feedback through resistor network R1-R2. When configured for bipolar output, the analog output is driven from the FORCE\_BIP test point and sensed by the SENSE\_BIP test point, with closed-loop feedback through resistor network R3-R4. (The analog output pin OUT is also connected to the standard Arduino A0 analog pin on the external connector.) For more information on these products, please visit:

- [www.maximintegrated.com/max5171](http://www.maximintegrated.com/max5171)
- [www.maximintegrated.com/max5173](http://www.maximintegrated.com/max5173)
- [www.maximintegrated.com/max889](http://www.maximintegrated.com/max889)
- [www.maximintegrated.com/max44260](http://www.maximintegrated.com/max44260)
- [www.maximintegrated.com/max6126](http://www.maximintegrated.com/max6126)

## Bipolar (-5V to 5V) Force/Sense Wiring Connection

To drive an output in the range -5V to 5V, put the FB shunt on pins 1-2, and connect both the FORCE\_BIP and SENSE\_BIP test points to the positive side of the load. Connect the ground return side of the load to the GND test point. Leave the FORCE\_UNI and SENSE\_UNI test points unconnected. For best accuracy, avoid the resistive ( $I \times R$ ) voltage drop losses in the supply wire by using two separate wires for FORCE and SENSE.



### Unipolar (0 to 5V) Force/Sense Wiring Connection

To drive an output in the range 0 to 5V, put the FB shunt on pins 2-3 (the MAX889 charge pump and MAX44260 op amp and resistors R3-R4 will not be used). Connect both the FORCE\_UNI and SENSE\_UNI test points to the positive side of the load. Connect the ground return side of the load to the GND test point. Leave the FORCE\_BIP and SENSE\_BIP test points unconnected. For best accuracy, avoid the resistive ( $I \times R$ ) voltage drop losses in the supply wire by using two separate wires for FORCE and SENSE.

### Minimal Component Count (0 to 2.5V) Force/Sense Wiring Connection

To drive an output in the range 0 to 2.5V with minimal component count, remove the FB shunt (the MAX889 charge pump and MAX44260 op amp and resistors

R1-R4 will not be used). Connect both the OUT and FB pins of the MAX5171 to the positive side of the load. Connect the ground return side of the load to the GND test point. Leave all other test points unconnected. For best accuracy, avoid the resistive ( $I \times R$ ) voltage drop losses in the supply wire by using two separate wires for OUT and FB.

### Evaluating the 2.7V to 3.6V MAX5173

The MAX5173 is the pin-compatible low-voltage version of MAX5171, specified for 2.7V to 3.6V operation. All on-board support circuitry (MAX889 charge pump, MAX44260 operational amplifier, and MAX6126 voltage reference) are specified to operate over the full 2.7V to 5.5V range. For specified operation of MAX5173, replace U3 with a 1.25V reference such as the pin-compatible MAX6190AESA+.

**Table 1. Jumper Functions**

JUMPER	STATE	FUNCTION
PDL	1-2*	PDL = logic-high: shutdown function is allowed.
	2-3	PDL = logic-low: shutdown function is disabled.
RS	1-2	RS = logic-high: output will be midscale at reset.
	2-3*	RS = logic-low: output will be zero at reset.
SHDN	1-2	SHDN = logic-high: MAX5171 is shut down.
	2-3*	SHDN = logic-low: normal operation.
FB	1-2* (BIP)	Bipolar output configuration (+5V/-5V): connect positive terminal of load to FORCE_BIP and SENSE_BIP test points.
	2-3 (UNI)	Unipolar output configuration (+5V): connect positive terminal of load to FORCE_UNI and SENSE_UNI test points.
J7	1-2*	Analog reference REF connects to Arduino pin A1
J6	1-2*	Analog output OUT connects to Arduino pin A0
J4	1-2*	VDD supply is driven by Arduino IOREF supply
J8	1-2*	User-programmable output UPO connects to Arduino pin D2
J1	1-2*	2.5V reference force/sense connection point
J5	1-2*	2.5V reference drives MAX5171 REF input

\*Default position

### Ordering Information

PART	TYPE
MAX5171BOB#	Breakout Board

#Denotes RoHS compliance.

MAX5171 Breakout Board Bill of Materials

ITEM	REF_DES	DNI/DNP	QTY	MFG PART #	MANUFACTURER	VALUE	DESCRIPTION
1	-5V	—	1	5119	KEystone	N/A	TEST POINT; PIN DIA = 0.1IN; TOTAL LENGTH = 0.3IN; BOARD HOLE = 0.04IN; PURPLE; PHOSPHOR BRONZE WIRE SILVER PLATE FINISH;
2	5V0	—	1	5000	KEystone	N/A	TEST POINT; PIN DIA = 0.1IN; TOTAL LENGTH = 0.3IN; BOARD HOLE = 0.04IN; RED; PHOSPHOR BRONZE WIRE SILVER PLATE FINISH;
3	C1-C3, C5, C6, C10	—	6	CC0603KRX7R0BB104; GRM188R72A104KA35; HMK107B7104KA; 06031C104KAT2A; GRM188R72A104K	YAGEO;MURATA; TAIYO YUDEN; AVX;MURATA	0.1µF	CAPACITOR; SMT (0603); CERAMIC CHIP; 0.1µF; 100V; TOL = 10%; TG = -55°C TO +125°C; TC = X7R
4	C4, C8	—	2	C1608X5R1A106K080AC	TDK	10µF	CAPACITOR; SMT (0603); CERAMIC CHIP; 10µF; 10V; TOL = 10%; MODEL = ; TG = -55° C TO +85° C; TC = X5R
5	C7	—	1	C1608X5R1E225K; TMK107ABJ225KA; TMK107BJ225KA; GRM188R61E225KA12	TDK; TAIYO YUDEN; TAIYO YUDEN; MURATA	2.2µF	CAPACITOR; SMT (0603); CERAMIC CHIP; 2.2µF; 25V; TOL = 10%; MODEL = ; TG = -55° C TO +85° C; TC = X5R
6	C11	—	1	C0603C475K8PAC; LMK107BJ475KA; CGB3B1X5R1A475K; C1608X5R1A475K080AC; CL10A475KP8NNN	KEMET; TAIYO YUDEN; TDK;TDK; SAMSUNG ELECTRONICS	4.7µF	CAPACITOR; SMT (0603); CERAMIC CHIP; 4.7µF; 10V; TOL = 10%; TG = -55° C TO +85° C; TC = X5R
7	FB, PDL, RS, SHDN	—	4	PEC03SAAN	SULLINS	PEC03SAAN	CONNECTOR; MALE; THROUGH HOLE; BREAKAWAY; STRAIGHT; 3PINS
8	FORCE_BIP, FORCE_UNI	—	2	5003	KEystone	N/A	TEST POINT; PIN DIA = 0.1IN; TOTAL LENGTH = 0.3IN; BOARD HOLE = 0.04IN; ORANGE; PHOSPHOR BRONZE WIRE SILVER PLATE FINISH;
9	GND	—	1	5001	KEystone	N/A	TEST POINT; PIN DIA = 0.1IN; TOTAL LENGTH = 0.3IN; BOARD HOLE = 0.04IN; BLACK; PHOSPHOR BRONZE WIRE SILVER PLATE FINISH;
10	J2, J3	—	2	PEC08SAAN	SULLINS ELECTRONICS CORP.	PEC08SAAN	CONNECTOR; MALE; THROUGH HOLE; .100IN CONTACT CENTER; MALE BREAKAWAY HEADER ; STRAIGHT; 8PINS
11	J9	—	1	SSQ-106-03-G-S	SAMTEC	SSQ-106-03-G-S	CONNECTOR; MALE; THROUGH HOLE; THROUGH-HOLE .025 SQ POST SOCKET ; STRAIGHT; 6PINS
12	J10, J12	—	2	SSQ-108-03-G-S	SAMTEC	SSQ-108-03-G-S	CONNECTOR; FEMALE; THROUGH HOLE; .025IN SQ POST SOCKET; STRAIGHT; 8PINS
13	J11	—	1	SSQ-110-03-G-S	SAMTEC	SSQ-110-03-G-S	CONNECTOR; FEMALE; THROUGH HOLE; .025IN SQ POST SOCKET; STRAIGHT; 10PINS
14	J21	—	1	TSW-106-08-S-D-RA	SAMTEC	TSW-106-08-S-D-RA	CONNECTOR; THROUGH HOLE; DOUBLE ROW; RIGHT ANGLE; 12PINS
15	R1-R4	—	4	CRCW060310K0FK; ERJ-3EKF1002	VISHAY DALE; PANASONIC	10K	RESISTOR; 0603; 10K; 1%; 100PPM; 0.10W; THICK FILM
16	SENSE_BIP, SENSE_UNI	—	2	5002	KEystone	N/A	TEST POINT; PIN DIA = 0.1IN; TOTAL LENGTH = 0.3IN; BOARD HOLE = 0.04IN; WHITE; PHOSPHOR BRONZE WIRE SILVER;
17	SU1-SU4	—	4	S1100-B;SX1100-B; STC02SYAN	KYCON;KYCON; SULLINS ELECTRONICS CORP.	SX1100-B	TEST POINT; JUMPER; STR; TOTAL LENGTH = 0.24IN; BLACK; INSULATION = PBT;PHOSPHOR BRONZE CONTACT = GOLD PLATED
18	U1	—	1	MAX44260AXT+	MAXIM	MAX44260AXT+	IC; OPAMP; 1.8V 15MHZ LOW-OFFSET, LOW-POWER, RAIL-TO-RAIL I/O OP AMP; SC70-6
19	U2	—	1	MAX889SESA+	MAXIM	MAX889SESA+	IC; VREG; 1MHZ SWITCHING FREQUENCY; HIGH-FREQUENCY; REGULATED; 0.2A; INVERTING CHARGE PUMP; NSOIC8 150MIL
20	U3	—	1	MAX6126A25+	MAXIM	MAX6126A25+	IC; VREF; ULTRA-HIGH PRECISION; ULTRA-LOW NOISE; SERIES VOLTAGE REFERENCE; UMAX8
21	U4	—	1	MAX5171AEEE+	MAXIM	MAX5171AEEE+	IC; DAC; LOW-POWER; SERIAL; 14-BIT DACS WITH FORCE/SENSE VOLTAGE OUTPUT; QSOP16 ;
22	UPO	—	1	5117	KEystone	N/A	TEST POINT; PIN DIA = 0.1IN; TOTAL LENGTH = 0.3IN; BOARD HOLE = 0.04IN; BLUE; PHOSPHOR BRONZE WIRE SILVER PLATE FINISH;
23	PCB	—	1	5171_ARDUINO_DEMO_A	MAXIM	PCB	PCB:5171_ARDUINO_DEMO_A
TOTAL			42				

MAX5171 Breakout Board Schematic Diagram

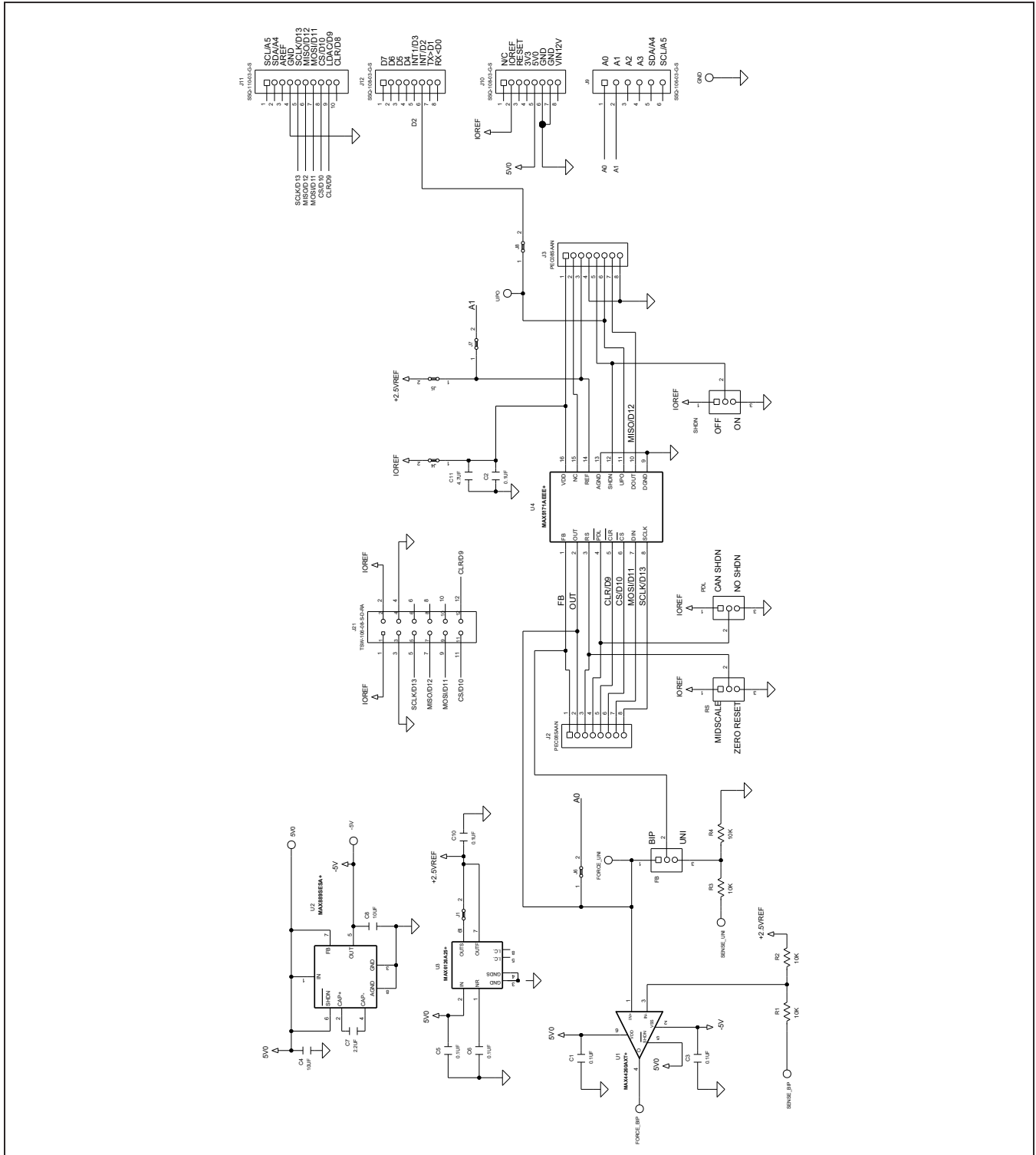

MAX5171 Breakout Board PCB Layout Diagrams

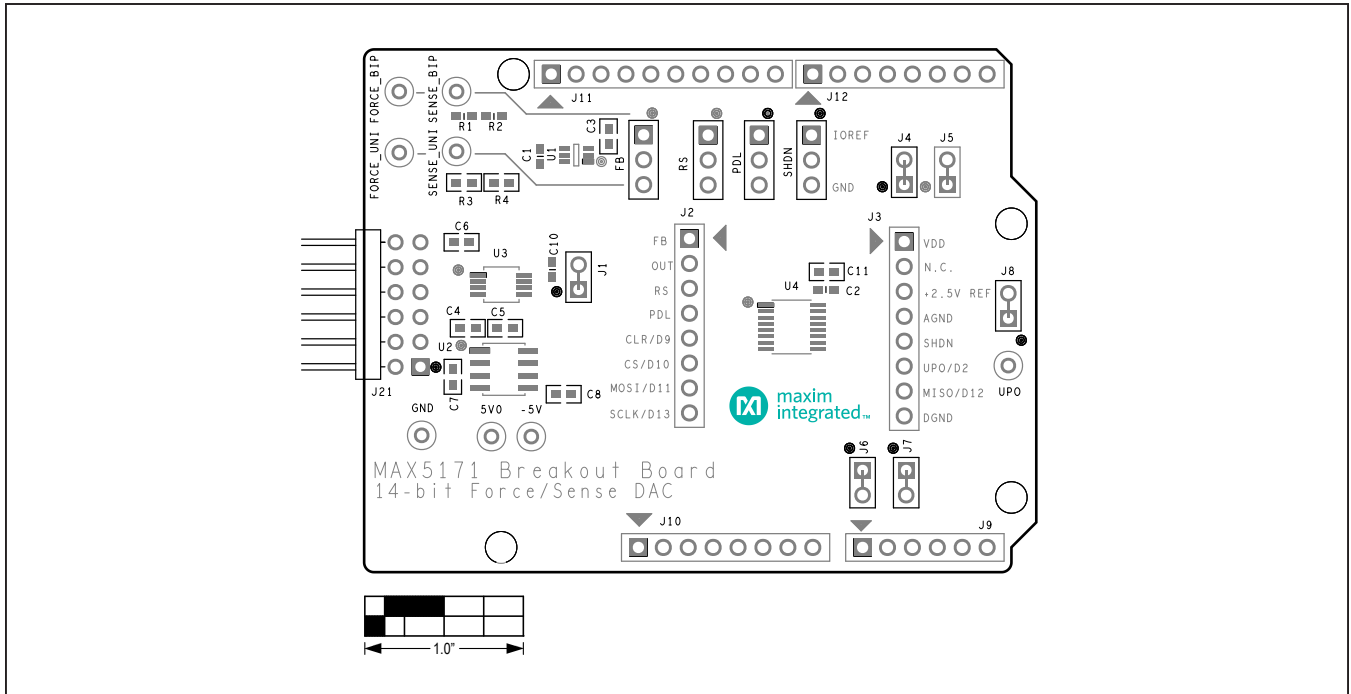

MAX5171 Breakout Board PCB Layout—Top Silkscreen

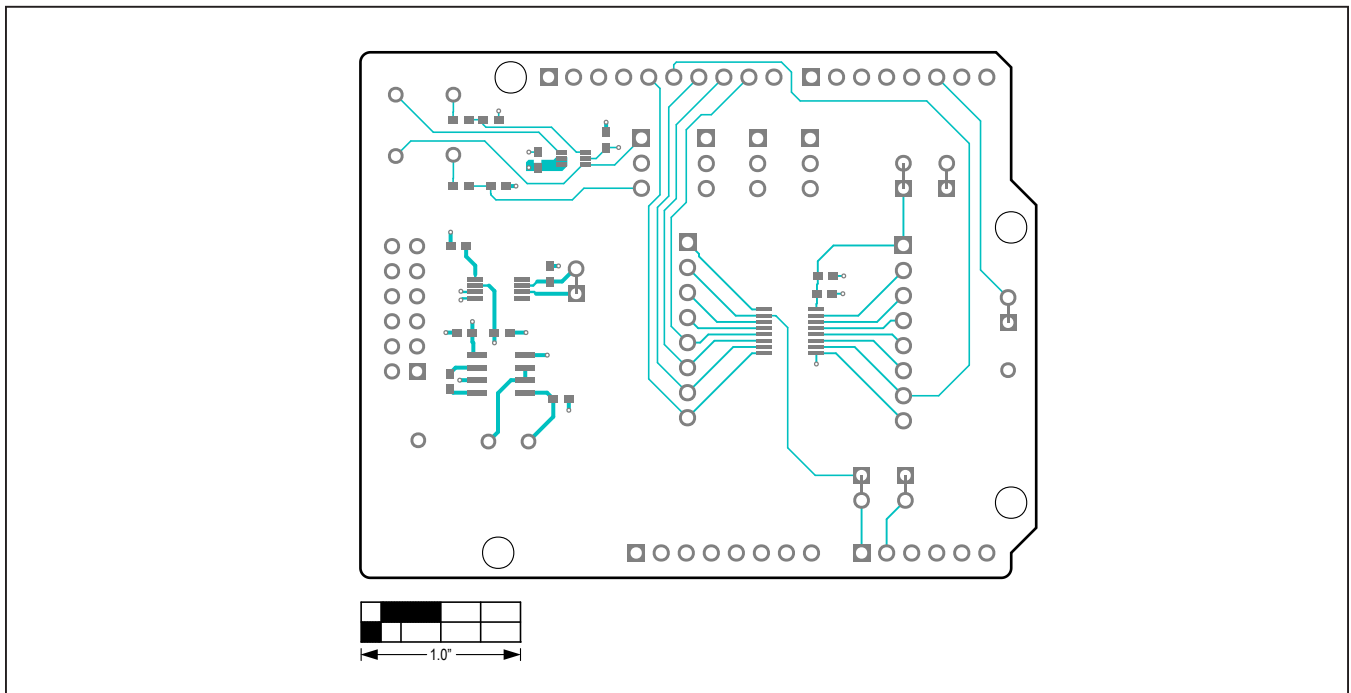

MAX5171 Breakout Board PCB Layout—Top View

MAX5171 Breakout Board PCB Layout Diagrams (continued)

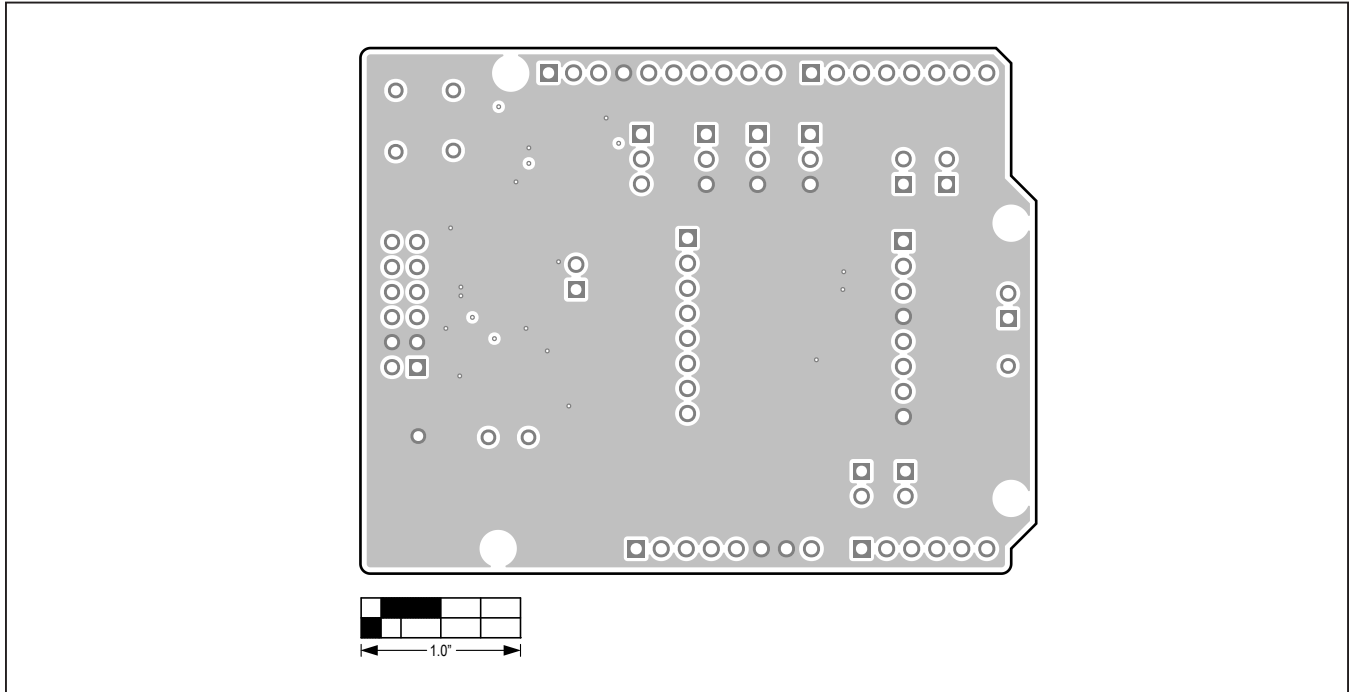

MAX5171 Breakout Board PCB Layout—Internal 2

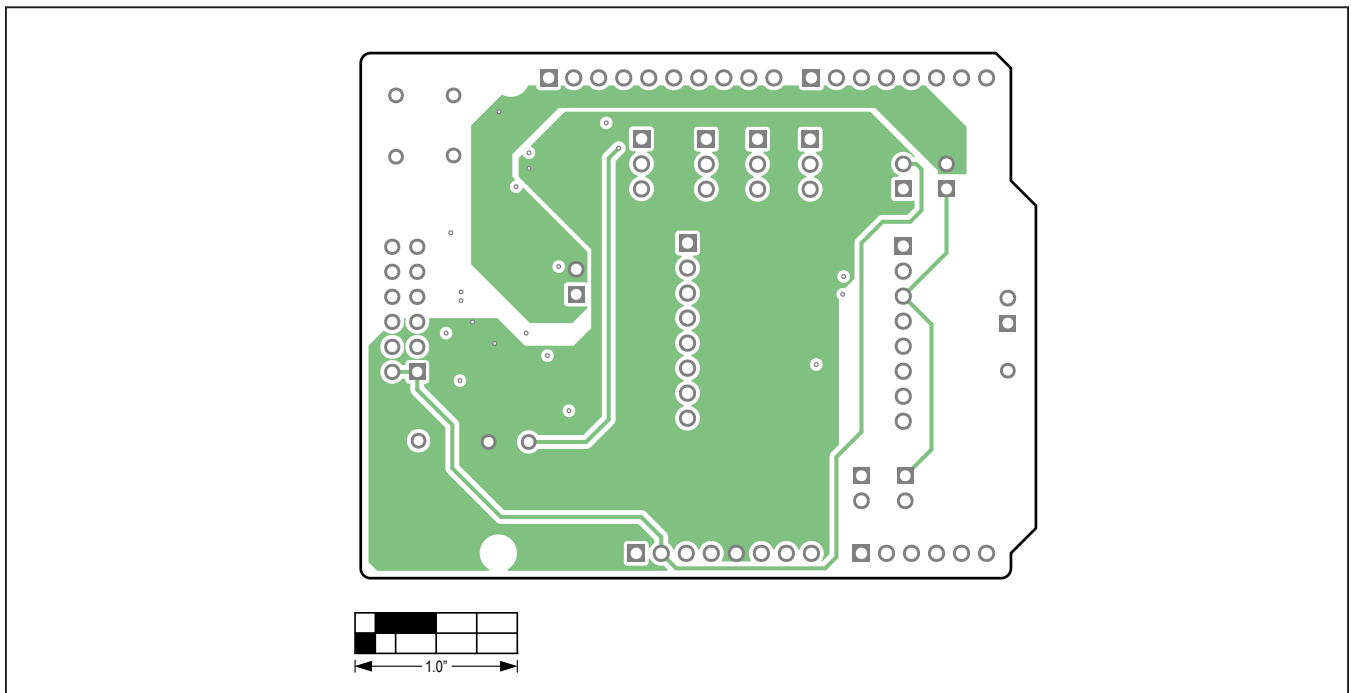

MAX5171 Breakout Board PCB Layout—Internal 3

MAX5171 Breakout Board PCB Layout Diagrams (continued)

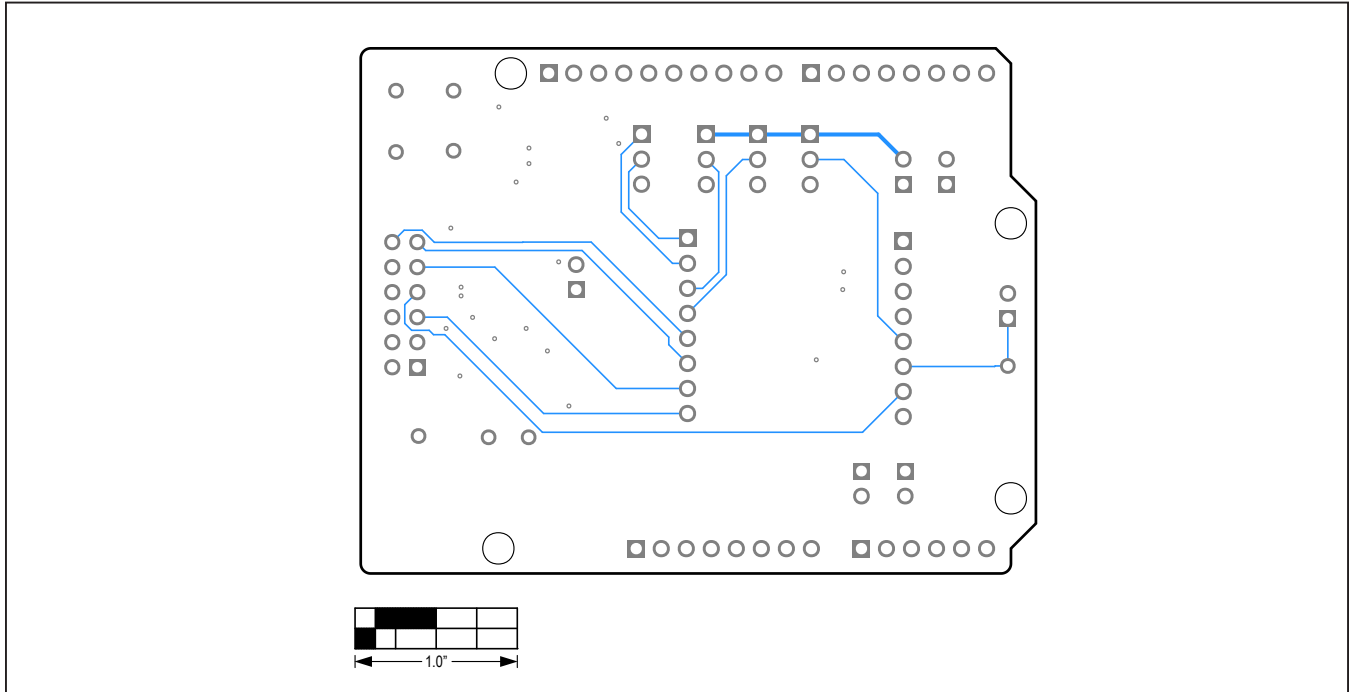

MAX5171 Breakout Board PCB Layout—Bottom View

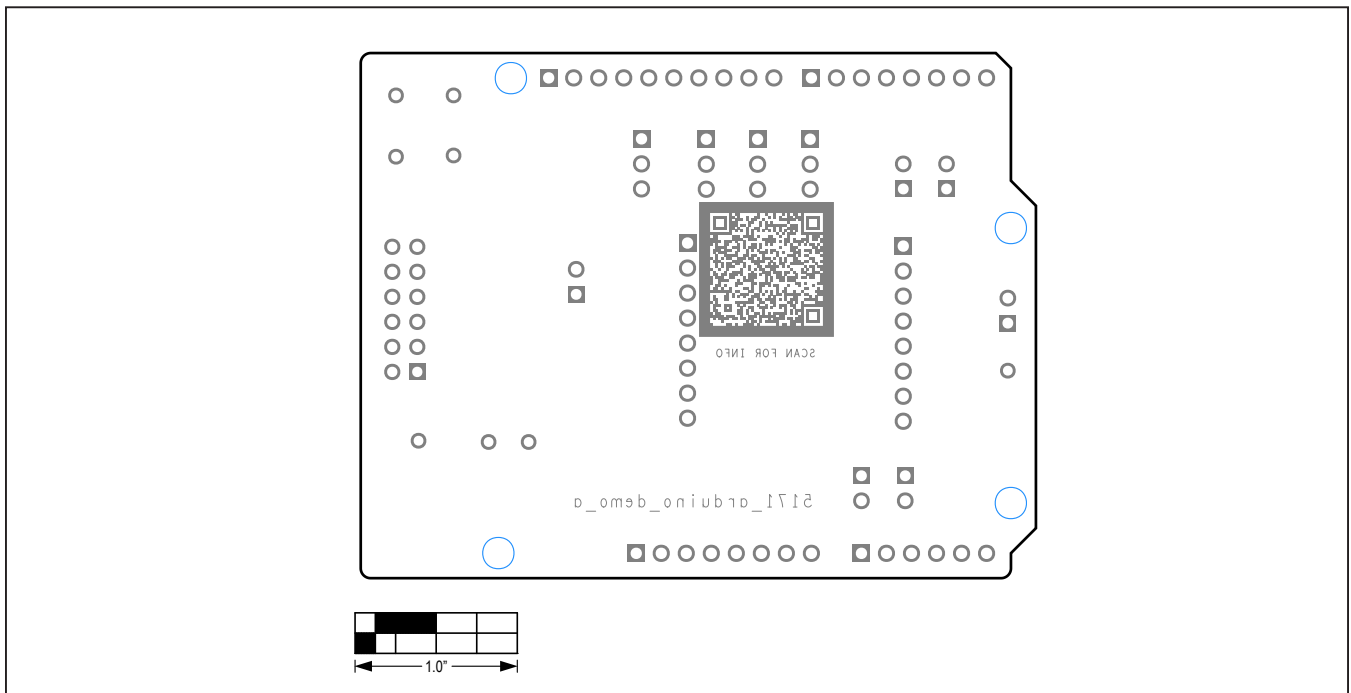

MAX5171 Breakout Board PCB Layout—Bottom Silkscreen

## Revision History

REVISION NUMBER	REVISION DATE	DESCRIPTION	PAGES CHANGED
0	11/20	Release for market intro	—

For pricing, delivery, and ordering information, please visit Maxim Integrated's online storefront at <https://www.maximintegrated.com/en/storefront/storefront.html>.

*Maxim Integrated cannot assume responsibility for use of any circuitry other than circuitry entirely embodied in a Maxim Integrated product. No circuit patent licenses are implied. Maxim Integrated reserves the right to change the circuitry and specifications without notice at any time.*