

Click [here](#) to ask about the production status of specific part numbers.

MAX586x Evaluation Kit

Evaluates: MAX5863/MAX5864/
MAX5865/MAX5866

General Description

The MAX586x evaluation kit (EV kit) is a fully assembled and tested circuit board that contains all the components necessary to evaluate the performance of this family of analog front ends (AFEs) that integrate a dual-channel analog-to-digital converter (ADC), a dual-channel digital-to-analog converter (DAC), and a 1.024V internal voltage reference. The EV kit board accepts AC- or DC-coupled, differential or single-ended analog inputs for the receive ADC and includes circuitry that converts the transmit DAC differential output signals to single-ended analog outputs. The EV kit includes circuitry that generates a clock signal from an AC sine wave input signal. The EV kit operates from a +3.0V analog power supply, +3.0V digital power supply, and $\pm 5V$ bipolar power supply.

The EV kit comes with Windows® 7/10-compatible software that provides a simple graphical user interface (GUI) for exercising the programmable features of the MAX5863–MAX5866.

Windows is a registered trademark and registered service mark of Microsoft Corporation.

Part Selection Table

PART	MAXIMUM SAMPLING SPEED (MSPS)
MAX5863ETM	7.5
MAX5864ETM	22
MAX5865ETM	40
MAX5866ETM	60

Component Suppliers

SUPPLIER	PHONE	FAX	WEBSITE
AVX	843-946-0238	843-626-3123	www.avxcorp.com
Kemet	864-963-6300	864-963-6322	www.kemet.com
Murata	770-436-1300	770-436-3030	www.murata.com
Pericom	800-435-2336	408-435-1100	www.pericom.com
Taiyo Yuden	800-348-2496	847-925-0899	www.t-yuden.com
TDK	847-803-6100	847-390-4405	www.component.tdk.com
Texas Instruments	972-644-5580	214-480-7800	www.ti.com

Note: Please indicate that you are using the MAX586x when contacting these component suppliers.

Features

- Quick Dynamic Performance Evaluation
- 50Ω Matched Clock Input and Analog Signal Lines
- Single-Ended to Fully Differential Analog Input Signal Configuration
- Differential to Single-Ended Output Signal-Conversion Circuitry
- AC- or DC-Coupled Input Signals Configuration
- SMA Coaxial Connectors for Clock Input, Analog Inputs, and Analog Output
- On-Board Clock-Shaping Circuit
- High-Speed PC Board Design
- Fully Assembled and Tested
- Windows-Compatible Software

Ordering Information

PART	TYPE
MAX5863EVKIT#	EV Kit
MAX5864EVKIT#	EV Kit
MAX5865EVKIT#	EV Kit
MAX5866EVKIT#	EV Kit

#Denotes ROHS compliant with exemption.

Component List

ITEM	REF_DES	QTY	VALUE	DESCRIPTION
1	+5V, GND	2		CONNECTOR; MALE; PANELMOUNT; BANANA JACK; STRAIGHT; 1PIN
3	C1-C8, C28-C31, C43, C66, C67, C79, C81-C89	25	0.1UF	0.1UF CERAMIC CAPACITOR; SMT (0402); 50V; 10%; X7R
4	C9-C15, C68	8	2.2UF	2.2UF CERAMIC CAPACITOR; SMT (0603); 16V; 10%; X7R
5	C16-C19	4	22PF	22PF CERAMIC CAPACITOR; SMT (0402); 50V; 5%; C0G
6	C20-C22, C26	4	1000PF	1000PF CERAMIC CAPACITOR; SMT (0402); 50V; 10%; X7R
7	C23-C25	3	0.33UF	0.33UF CERAMIC CAPACITOR; SMT (0603); 25V; 10%; X5R;
8	C27, C69	2	2.2UF	2.2UF CERAMIC CAPACITOR; SMT (0603); 6.3V; 10%; X5R;
9	C32-C34, C36-C39, C42, C44-C53, C93	19	0.1UF	0.1UF CERAMIC CAPACITOR; SMT (0603); 100V; 10%; X7R
10	C35, C40	2	4.7UF	4.7UF TANTALUM CAPACITOR; SMT (3528); 16V; 20%
11	C41, C60-C64, C70, C73, C74, C76	10	10UF	10UF CERAMIC CAPACITOR; SMT (0805); 6.3V; 20%; X5R
12	C54, C65	2	22UF	22UF CERAMIC CAPACITOR; SMT (0603); 6.3V; 20%; X5R
13	C55	1	4.7UF	4.7UF CERAMIC CAPACITOR; SMT (1206); 50V; 10%; X5R
14	C71, C90-C92	4	0.01UF	0.01UF CERAMIC CAPACITOR; SMT (0603); 50V; 5%; X7R
15	C72, C75	2	1UF	1UF CERAMIC CAPACITOR; SMT (0402); 6.3V; 10%; X7R
16	C77, C78	2	8PF	8PF CERAMIC CAPACITOR; SMT (0402); 50V; +/-0.25PF; C0G;
17	C80	1	3.3UF	3.3UF CERAMIC CAPACITOR; SMT (0402); 6.3V; 20%; X5R
18	CLOCK, IA, ID, QA, QD	5	132322	CONNECTOR; FEMALE; BOARDMOUNT; SMA END LAUNCH RECEPT. JACK; STRAIGHT; 5PINS
19	D1	1	B160B-13-F	B160B-13-F DIODE; SCH; SMB (DO-214AA); PIV=60V; IF=1A
20	DS1-DS6	6	LGL29K-G2J1-24-Z	LGL29K-G2J1-24-Z DIODE; LED; SMARTLED; GREEN; SMT; PIV=1.7V; IF=0.02A
21	J1, J2	2	PEC10DAAN	PEC10DAAN CONNECTOR; MALE; THROUGH HOLE; BREAKAWAY; STRAIGHT; 20PINS
22	J3-J5, J13, JU6, JU8-JU10	8	PEC03SAAN	PEC03SAAN CONNECTOR; MALE; THROUGH HOLE; BREAKAWAY; STRAIGHT; 3PINS

Component List (continued)

ITEM	REF_DES	QTY	VALUE	DESCRIPTION
23	J6	1	897-43-005-00-100001	CONNECTOR; FEMALE; SMT; USB MINI B-TYPE SMT CONNECTOR WITH DOWEL PINS; RIGHT ANGLE; 9PINS
24	J7-J10, J12, J14, JU11	7	PEC02SAAN	CONNECTOR; MALE; THROUGH HOLE; BREAKAWAY; STRAIGHT; 2PINS
25	J11	1	PEC08DAAN	CONNECTOR; MALE; THROUGH HOLE; BREAKAWAY; STRAIGHT; 16PINS
26	JU1, JU4	2	TSW-104-07-L-S	CONNECTOR; MALE; THROUGH HOLE; STRAIGHT; 4PINS
27	JU2, JU3, JU5, JU7	4	TSW-103-07-G-S	CONNECTOR; MALE; THROUGH HOLE; STRAIGHT; 3PINS ;
28	L1, L2	2	28	INDUCTOR; SMT (0603); FERRITE-BEAD; 28; TOL=+/-25%; 4A
29	L3	1	600	INDUCTOR; SMT (0603); FERRITE-BEAD; 600; TOL=+/-; 0.5A
30	MH1, SPACER1-SPACER3	4	9032	MACHINE FABRICATED; ROUND-THRU HOLE SPACER; NO THREAD; M3.5; 5/8IN; NYLON
31	R1-R4	4	24.9	RESISTOR; 0402; 24.9 OHM; 1%; 100PPM; 0.0625W; THICK FILM
32	R5-R9	5	2K	RESISTOR; 0603; 2K OHM; 1%; 100PPM; 0.125W; THICK FILM
33	R10, R11	2	4.02	RESISTOR; 0603; 4.02 OHM; 1%; 100PPM; 0.10W; THICK FILM
34	R12	1	6.04K	RESISTOR; 0603; 6.04K; 1%; 100PPM; 0.10W; THICK FILM
35	R13	1	5K	RESISTOR; THROUGH HOLE; 3262 SERIES; 5K OHM; 10%; 100PPM; 0.25W
36	R14-R21	8	10K	RESISTOR; 0603; 10K OHM; 1%; 100PPM; 0.0125W; THICK FILM
37	R29, R32, R64	3	0	RESISTOR; 0603; 0 OHM; 5%; JUMPER; 0.10W; THICK FILM
38	R30, R31, R33-R35	5	49.9	RESISTOR; 0603; 49.9 OHM; 1%; 100PPM; 0.10W; THICK FILM
39	R37-R44	8	100	RESISTOR; 0603; 100 OHM; 5%; 200PPM; 0.10W; THICK FILM
40	R45-R53, R70	10	51	RESISTOR; 0603; 51 OHM; 5%; 200PPM; 0.1W; THICK FILM
41	R54-R63	10	51	RESISTOR; 0402; 51 OHM; 1%; 100PPM; 0.063W; THICK FILM
42	R65, R86-R88	4	100	RESISTOR; 0603; 100 OHM; 1%; 100PPM; 0.10W; THICK FILM
43	R66-R68, R83-R85	6	10K	RESISTOR; 0603; 10K OHM; 5%; 200PPM; 0.10W; THICK FILM
44	R69	1	2.2K	RESISTOR; 0603; 2.2K OHM; 5%; 200PPM; 0.10W; THICK FILM
45	R81	1	1K	RESISTOR; 0603; 1K OHM; 5%; 200PPM; 0.10W; THICK FILM
46	R82	1	12K	RESISTOR, 0603, 12K OHM, 1%, 100PPM, 0.10W, THICK FILM
47	R89, R90	2	270	RESISTOR; 0603; 270R; 1%; 100PPM; 0.10W; THICK FILM
48	R91	1	100K	RESISTOR; 0603; 100K OHM; 5%; 200PPM; 0.10W; THICK FILM
49	R92	1	59K	RESISTOR; 0603; 59K OHM; 1%; 100PPM; 0.1W; THICK FILM
50	S1	1	B3S-1000P	SWITCH; SPST; SMT; 24V; 0.05A; NORMALLY OPEN
51	SU1-SU20	20	SX1100-B	TEST POINT; BLACK

Component List (continued)

ITEM	REF_DES	QTY	VALUE	DESCRIPTION
52	T1, T2	2	TTWB3010-1L	TRANSFORMER; SMT; 200MHZ; WIDEBAND RF TRANSFORMER
53	TP1	1	N/A	TEST POINT; PIN DIA=0.1IN; TOTAL LENGTH=0.3IN; BOARD HOLE=0.04IN; YELLOW; PHOSPHOR BRONZE WIRE SILVER PLATE FINISH;
54	TP2	1	N/A	TEST POINT; PIN DIA=0.1IN; TOTAL LENGTH=0.3IN; BOARD HOLE=0.04IN; RED; PHOSPHOR BRONZE WIRE SILVER PLATE FINISH;
55	TP3	1	N/A	TEST POINT; PIN DIA=0.1IN; TOTAL LENGTH=0.3IN; BOARD HOLE=0.04IN; BLACK; PHOSPHOR BRONZE WIRE SILVER PLATE FINISH;
56	U1	1	MAX586xETM+	IC; AFEC; ULTRA-LOW-POWER; HIGH-DYNAMIC-PERFORMANCE; ANALOG FRONT END; TQFN48-EP
57	U2	1	MAX9113ESA+	IC; LRX; DUAL LVDS LINE RECEIVER WITH ULTRA-LOW PULSE; NSOIC8 150MIL; -40 DEGC TO +85 DEGC
58	U3	1	MAX4128ESA+	IC; OPAMP; DUAL; WIDE-BANDWIDTH; LOW-POWER SINGLE-SUPPLY; RAIL-TO-RAIL I/O OP AMPS; NSOIC8
59	U4	1	MAX889RESA+	IC; VREG; 0.5MHZ SWITCHING FREQUENCY; HIGH-FREQUENCY; REGULATED; 0.2A; INVERTING CHARGE PUMP; NSOIC8 150MIL
60	U5	1	SN74ALVCH16244DGGR	IC; BUF; 16-BIT BUFFER WITH 3-STATE OUTPUT; TSSOP48
61	U6-U8, U13	4	MAX8902AATA+	IC; VREG; LOW-NOISE LDO REGULATOR PIN-SELECTABLE OUTPUT VOLTAGE; TDFN8 2X2
62	U9	1	93LC56BT-I/SN	IC; EEPROM; 2K; 16-BIT MICROWIRE COMPATIBLE SERIAL EEPROM; NSOIC8 150MIL
63	U10	1	MAX8511EXK33+	IC; VREG; ULTRA-LOW-NOISE, HIGH PSRR, LOW-DROPOUT, LINEAR REGULATOR; SC70-5
64	U11	1	FT4232HL	IC; USB; QUAD HIGH SPEED USB TO MULTIPURPOSE UART/MPSSE IC; LQFP64 12X12
65	U12	1	SN74AVC4T774PW	IC; TXRX; 4-BIT DUAL-SUPPLY BUS TRANSCEIVER WITH CONFIGURABLE VOLTAGE TRANSLATION AND 3-STATE OUTPUT; TSSOP16
66	Y1	1	12MHZ	CRYSTAL; SMT NO DATA; 18PF; 12MHZ; +/-30PPM; +/-50PPM
67	PCB	1	PCB	PCB:MAX586x
68	C56-C59	0	OPEN	PACKAGE OUTLINE 0402 NON-POLAR CAPACITOR
69	R22-R26, R27	0	OPEN	PACKAGE OUTLINE 0402 RESISTOR
70	R28, R36	0	SHORT	PACKAGE OUTLINE 0603 RESISTOR
TOTAL		266		

MAX586x EV Kit Software Files

FILE	DESCRIPTION
ftd2xx.dll	FTDI USB interface driver library
libMPSSE.dll	USB to Single Ended interface library
MaximStyle.dll	Maxim object library
FTD2XX_.NET.dll	FTDI USB interface .NET library
MAX586xGUI.exe	MAX586x application GUI executable
unins000.exe	Uninstall executable
unins000.dat	Uninstall data file
unins000.msg	Uninstall support file

Quick Start

Recommended Equipment

- One +5.0V ±0.25V DC power supply
- One function generator with low phase noise and low jitter for clock input (e.g., R&S SMC100A)
- Two function generators for single-ended analog inputs (e.g., R&S SMC100A)
- One 10-bit digital pattern generator for data inputs (e.g., Link Instruments IO3232A)
- Two spectrum analyzers (e.g., HP 8560E)
- One logic analyzer or data-acquisition system (e.g., Link Instruments IO3232A)
- Voltmeter
- Oscilloscope
- MAX586x evaluation software
- Windows 10 computer with a spare USB port
- Analog input filters (select appropriate ADC input filters per application specific)

Procedure

The MAX586x AFE EV kit is a fully assembled and tested surface-mount board. The board is highly configurable through various jumper options. The following steps provide basic instructions for system operation using the transformer coupled ADC inputs and the amplifiers for the DAC outputs. **Do not turn on power supplies or enable signal generators until all connections are completed:**

- 1) Install the evaluation software on your computer by running the MAX586xAFEVKitSoftwareInstaller.exe program. The program files are copied and icons are created for them in the Start menu.
- 2) Verify the shunts are installed in their default positions for JU1, JU2, JU9, JU3, JU4, and JU10 (see Table 4)

(single-ended analog signals IA and QA converted to differential input signals with transformers T1 and T2).

- 3) Verify that shunts are installed across pins 2 and 3 of jumpers JU5, JU6, and JU8; and across pins 2 and 3 for JU7 (differential analog output signals converted to single-ended signals ID and QD with operational-amplifier U3).
- 4) Verify that a shunt is installed across the jumper JU11 (internal reference).
- 5) Connect USB cable between the EV kit board and the PC.
- 6) Connect the clock-function signal generator (HP 8662A) between the IA and QA SMA connectors to the CLOCK SMA connector on the EV kit.
- 7) Connect the two function generators to SMA connectors IA and QA.
- 8) Synchronize the two function generators to the clock function generator.
- 9) Connect the logic analyzer to the 2 x 10 square pin header J1. The CLOCK signal is available on pin J1-1 and bits DA0–DA7 are available on the odd pins J1-3 through J1-19. All other header J1 pins are connected to ground. The clock pin and data pins are labeled CLK and DA0–DA7 on the EV board.
- 10) Verify that the logic analyzer is programmed for an 8-bit input at CMOS voltage levels.
- 11) Verify that the 10-bit digital pattern generator is programmed for valid CMOS output voltage levels.
- 12) Connect the digital pattern generator IO3232A output to the J2 input header connector on the EV kit board. The input header pins are labeled for proper connection with the digital pattern generator (i.e., connect bit 0 to the J2-1 header pin labeled DD0, connect bit 1 to the J2-3 header pin labeled DD1, etc. Input data pins are the odd pins of header J2. All other pins are connected to ground).
- 13) Synchronize the digital pattern generator with the clock function generator.
- 14) Using USB power, verify J13 is connected 1-to-2. Verify J14, J7, J9, J8, J10, and J12 are all installed. Verify J4, J3, and J5 are connected 2-to-3.
- 15) Using external power, connect a +5.0V supply to the +5V banana jack and connect the ground terminal to the GND banana jack. Switch the J13 jumper connecting 2 to 3.
- 16) If using an external +5.0V power source, turn on that supply.

MAX586x Evaluation Kit

Evaluates: MAX5863/MAX5864/
MAX5865/MAX5866

- 17) Probe resistor pad R28 with an oscilloscope and adjust potentiometer R13 to set the clock duty cycle to 50%.
- 18) Start the MAX586x program by opening its icon in the Start menu.
- 19) Click on the **XCVR (Transceiver)** radio button in the **Control Commands/Select Operation Mode** block to set the MAX586x in receive/transmit (transceiver) operational mode.
- 20) Enable the clock function generator (HP 8662A). Set the clock function generator output power to 2.4V_{P-P} (11.6dBm) and the frequency (f_{CLK}) to greater than 22MHz but less than or equal to 40MHz.
- 21) Enable the function generators.
- 22) Set the IA function-generator output signal to 1.024V_{P-P} and the frequency to $\leq f_{CLK}/2$.
- 23) Set the QA function-generator output signal to 1.024V_{P-P} and the frequency to $\leq f_{CLK}/2$.
- 24) Use the logic analyzer to analyze the 8-bit ADC digital output. The IA channel digital data is available on the falling edge of the clock. The QA digital data is available on the rising edge of the clock. Ensure that the ADC input is not overdriven by observing the output digital codes and adjusting the input signal level for code of -0.5dB full scale.
- 25) Enable the digital pattern generator. Program the digital pattern generator to transmit the digital data for the DAC I channel on the falling edge of the clock and transmit the digital data for the Q channel on the rising edge of the clock.
- 26) Connect the spectrum analyzers to the ID and QD SMA connectors to analyze the analog outputs.
- 27) Use the spectrum analyzer to analyze the analog output spectrum or view the analog output waveforms using an oscilloscope.

Detailed Description of Software

The evaluation software's main window (shown in Figure 1) can be used to program the MAX586x to one of the six operational modes: Shutdown, Standby, Idle, RX, TX, and XCVR (Transceiver).

Click one of the buttons to program the MAX586x to the desired operational mode after power has been applied to the EV kit. See Table 1 for the description of each operational mode.

The MAX586x evaluation software uses a 3-wire bit-banging interface that is compatible with SPI™/QSPI™/MICROWIRE™/DSP interfaces to program the MAX586x through the USB port on the computer. Table 1 lists the byte command for each operational mode.

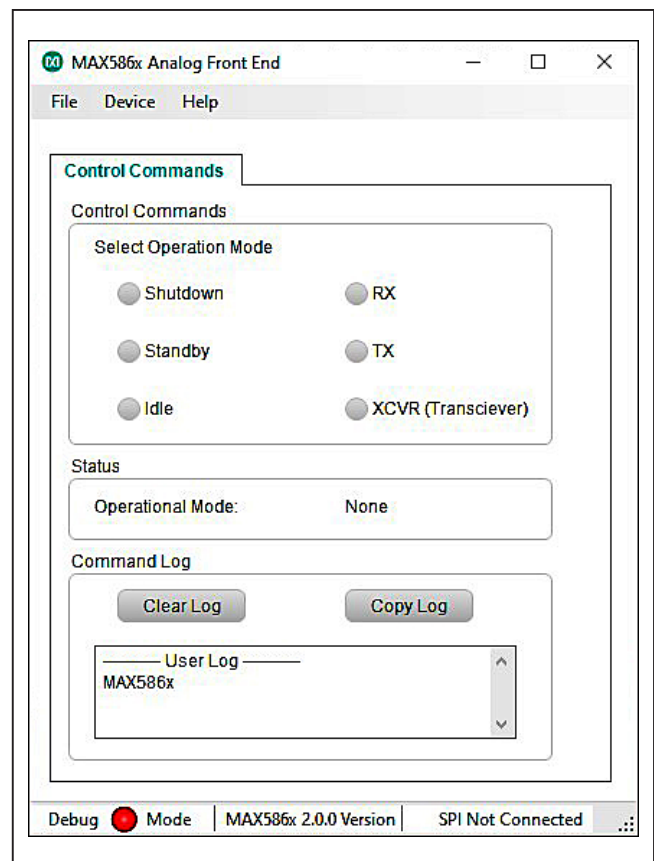

Figure 1. MAX586x EV Kit Software Main Window

SPI and QSPI are trademarks of Motorola, Inc.
MICROWIRE is a trademark of National Semiconductor Corp.

Table 1. Operational Modes

MODE	EV KIT FUNCTION	COMMAND BYTE SENT TO MAX586x
Shutdown	Device shutdown. REF is off, ADCs are off, the ADC bus is tri-stated, and DACs are off. The DAC input bus must be set to zero or OV_{DD} to achieve the lowest shutdown-mode power consumption.	xxxx x000
Standby	REF is on, ADCs are off, the ADC bus is tri-stated, and DACs are off. The DAC input bus must be set to zero or OV_{DD} to achieve the lowest standby-mode power consumption.	xxxx x101
Idle	REF is on, ADCs are off, the ADC bus is tri-stated, and DACs are off. The DAC input bus must be set to zero or OV_{DD} to achieve the lowest Idle Mode™ power consumption.	xxxx x001
RX	REF is on, ADCs are on, and DACs are off. The DAC input bus must be set to zero or OV_{DD} to achieve the lowest Rx-mode power consumption.	xxxx x010
TX	REF is on, ADCs are off, the ADC bus is tri-stated, and DACs are on.	xxxx x011
XCVR (Transceiver)	REF is on, ADCs and DACs are on.	xxxx x100

x = Don't care

Detailed Description of Hardware

The MAX586x EV kit is a fully assembled and tested circuit board that contains all the components necessary to evaluate the performance of the MAX5866, MAX5865, MAX5864, or MAX5863 analog front end. The MAX5863/MAX5864/MAX5865/MAX5866 integrate a 1.024V temperature-stable voltage reference, a dual-input 8-bit parallel-output receive ADC, and a 10-bit parallel-input dual-output transmit DAC. The MAX5863/MAX5864/MAX5865/MAX5866 accept AC-coupled or DC-coupled, differential, or single-ended analog inputs at the receive ADC. The digital output produced by the ADC can be easily captured with a high-speed logic analyzer or data-acquisition system. The MAX5863/MAX5864/MAX5865/MAX5866 digital inputs at the transmit DAC are designed for CMOS-compatible voltage levels. The DAC produces differential analog outputs with 1.4VDC common mode.

The EV kit operates from a +3.0V analog power supply, +3.0V digital power supply, and ±5V bipolar operational amplifier power supply. For best dynamic performance, set the digital power supply to +2V. The EV kit includes circuitry that generates a clock signal from an AC sine wave provided by the user. Other features include: circuitry to convert single-ended inputs to differential input analog signals and circuitry to convert the differential outputs of the DAC to single-ended analog signals.

Idle Mode is a trademark of Maxim Integrated Products, Inc.

Power Supplies

The MAX586x evaluation kit can operate from the +5V USB supply or an external +5.0V power source connected to the “+5V” and “GDN” banana jacks. This master supply is used to generate the VDD (+3.0V), VCLK (+3.0V), OVDD (+3.0V), VCC (+3.0V) and VEE (-3.0V) power rails through several on-board regulators. The EV kit PC board ground layer is a continuous plane, providing strong signal integrity between the analog and digital sections of the AFE. Likewise, several supply connections are made through a shared, sectioned, power plane (layer 3, see Figure 10) allowing low-inductance connections between the on-board regulator and the respective power pins of the MAX586x. Using separate power supplies for each internal AFE block reduces crosstalk and improves the signal integrity of both the analog waveforms and the digital interfaces. Another advantage of using separate power supply connections is the flexibility of input sources: the user is not forced to drive the same voltage level to each supply on the EV kit sub-circuit. VDD has a +2.7V to +3.3V input range with a nominal value of +3.0V. OVDD has a +1.8V to VDD input range with a nominal +3.0V setting and VCLK has a +2.7V to +3.3V input range with a nominal +3.0V value.

Clock Signal

An on-board clock-shaping circuit generates a clock signal from an AC sine wave signal applied to the CLOCK SMA connector. The input clock signal should not exceed a magnitude of 2.6V_{P-P}. The frequency of the signal determines the sampling frequency (f_{CLK}) of the MAX586x EV kit circuit and should not exceed 60MHz. The differential line receiver (U2) processes the input signal to generate the CMOS clock signal. The clock signal's duty cycle can be adjusted with potentiometer R13. A 50% duty cycle is recommended. The clock signal is available at the J1-1 header pin (CLK) and can be used as the external clock for the logic analyzer.

Transmit Dual 10-Bit DAC Input

The MAX586x integrates a dual 10-bit DAC capable of operating with clock speeds up to 60Msps. The digital data for the I and Q channels are alternately clocked onto the DAC's bus DD0–DD9. Data for the I channel is latched on the falling edge of the clock signal and data for the Q channel is latched on the rising edge of the clock signal. The MAX586x EV kit provides a 0.1in 2 x 10 header (J2) to interface a 10-bit CMOS pattern generator to the EV kit. The header data pins are labeled on the board with the appropriate data bits designation. Use the labels on the EV kit to match the data bits from the pattern generator to the corresponding data pins on header J2. Header pins J2-1 through J2-19 (odd pins) are data pins DD0–DD9. All other header pins are connected to ground GND.

Transmit Dual DAC Outputs

The MAX586x transmit DAC outputs are ±400mV_{P-P} full-scale differential analog signals and are biased to 1.4VDC common mode. The full-scale output and DC common-mode level are set by the internal voltage reference. A variation in the reference voltage results in proportional changes to the DAC full-scale output and the DC common-mode level. The ID and QD outputs are simultaneously updated on the rising edge of the clock signal. The differential ID and QD output signals can be sampled at the IDP, IDN, QDP, and QDN PC pads or converted to single-ended signals using on-board operational-amplifier circuits. Configure jumpers JU5, JU6, JU7, and JU8 to select the output signal format. See Tables 2 and 3 to configure jumpers JU5–JU8. When jumpers JU5–JU8 are configured for operational-amplifier conversion, the differential signals are converted into a 50Ω single-ended signal with operational amplifier pair, U3. The single-ended output signals can be sampled at the ID SMA connector for the ID channel and QD SMA connector for the QD channel. When jumpers JU5–JU8 are configured for DC-coupled differential outputs, the DC-coupled differential signals can be sampled at the IDP and IDN PC pads for the ID channel. The QD channel can be probed at the QDP and QDN PC pads.

Table 2. DAC ID Channel Analog Output Selection

JU5 POSITION	JU6 POSITION	EV KIT FUNCTION
open	open	ID channel DC-coupled differential output available at the JU5-2 pin (DAC voltage output) and JU6-2 pin (complementary DAC voltage output)
2-3	2-3	ID channel differential output converted to single-ended signal using operational amplifier configuration; available at ID SMA connector

Table 3. DAC QD Channel Analog Output Selection

JU7 POSITION	JU8 POSITION	EV KIT FUNCTION
open	open	QD channel DC-coupled differential output available at the JU7-2 pin (DAC voltage output) and JU8-2 pin (complementary DAC voltage output)
1-2	2-3	QD channel differential output converted to single-ended signal using operational amplifier configuration; available at QD SMA connector

Receive Dual ADC Analog Inputs

The MAX586x integrates a dual 8-bit ADC that accepts differential or single-ended analog input signals. The inputs are simultaneously sampled on the rising edge of the clock. The EV kit is designed to accept differential or single-ended, AC- or DC-coupled input signals with full-scale amplitude of less than 1.024V_{P-P} (+4dBm). Ensure that the ADC input is not overdriven by observing the output digital codes and adjusting the input signal level for code of -0.5dB full scale. See Table 4 for instructions to configure jumpers JU1, JU2, JU3, JU4, JU9, and JU10 for the desired analog input. During single-ended operation the signal is applied directly to the ADC input. While in differential mode, an on-board transformer uses the single-ended analog input to generate a differential analog signal that is applied at the ADC’s differential input pins.

The EV kit does not include analog input filters for the ADC channels. Note that function generators exhibit high harmonic distortions that could degrade the true performance of the ADC. Select appropriate filters per specific applications, test tones, and improve the signal integrity of the function generators.

Note: When a differential signal is applied to the ADC, the positive and negative input pins of the ADC each receive half of the input signal supplied at SMA connectors IA and QA with an offset voltage of VDD/2.

Receive Dual 8-Bit ADC Output

The 8-bit digital output data for the IA and QA channels are multiplexed at output data bus DA0–DA7. The IA channel data is available on the falling edge of the clock. The QA channel data is available on the rising edge of the clock. The MAX586x EV kit provides a 0.1in 2 x 10 header (J1) to interface with a logic-analyzer or data-acquisition system. The header data pins are labeled on the board with the appropriate data bit designations. Use the labels on the EV kit to match the output data bits to the data-acquisition system. Header pins J1-3 through J1-17 (odd pins) are data pins DA0–DA7. Header pin J1-1 is a clock signal pin. All other header pins are connected to ground GND.

Reference Voltage Options

The MAX586x provides two reference modes of operation that can be selected by applying a voltage input to the REFIN pin. The reference voltage sets the full-scale input voltage of the ADC and the full-scale output voltage of the DAC. The MAX586x EV kit provides jumper JU11 and the REFIN PC board pad that allows access to the input pin and selects one of the two reference modes: internal reference mode or buffered external reference mode. See Table 5 for instructions to select the voltage reference mode. Using an external reference enhances accuracy and drift performance or can be used for gain control.

Table 4. Single-Ended/Differential/AC-Coupled/DC-Coupled Jumper Configuration

JUMPER	SHUNT POSITION	PIN CONNECTION	EV KIT OPERATION
JU1	1–4	IA+ pin assumes the DC offset at REFP and REFN and connects to the IA SMA through C28.	Single-ended input, AC-coupled. Analog input signal is applied to the IA SMA connector, channel IA : • R26 opened (default).
JU2	1-2	IA- pin connected to COM pin through R2 and T1.	
JU9	1-2	IA SMA bypasses the T1 transformer through C28.	
JU1	1–4	IA+ pin connected to the IA SMA through R26.	Single-ended input, DC-coupled. Analog input signal is applied to the IA SMA connector, channel IA : • R26 shorted (0Ω) • C28 opened (removed) • R29 opened (removed)
JU2	1-2	IA- pin connected to COM pin through R2 and T1.	
JU9	1-2	IA+ pin assumes the DC offset from the analog input source.	
JU1	1-2*	IA+ pin connected to pin 6 of transformer T1 through R1.	Differential input, AC-coupled. Single-ended analog input signal is applied to IA SMA connector, channel IA .
JU2	1-2*	IA- pin connected to pin 4 of transformer T1 through R2.	
JU9	2-3*	IA+ SMA connector to pin 1 of transformer T1 through C66.	

Table 4. Single-Ended/Differential/AC-Coupled/DC-Coupled Jumper Configuration (continued)

JUMPER	SHUNT POSITION	PIN CONNECTION	EV KIT OPERATION
JU1	open	IA+ pin DC-coupled to the JU1-1 pin (with JU1-3 as GND) through R1.	Differential input, DC-coupled. Analog input signals are applied to the JU1-1 pin and the JU2-2 pin, channel IA.
JU2	open	IA- pin DC-coupled to the JU1-1 pin (with JU2-3 as GND) through R2.	
JU9	N/A	IA SMA not used.	
JU3	2-3	QA- pin connected to COM through R4 and T2.	Single-ended input, AC-coupled. Analog input signal is applied to the QA SMA connector, channel QA: • R27 opened (default)
JU4	1-2	QA+ pin assumes the DC offset at REFP and REFN and connects to the QA SMA through C30.	
JU10	1-2	QA SMA bypasses the T2 transformer through C30.	
JU3	2-3	QA- pin connected to COM pin through R4 and T2.	Single-ended input, DC-coupled. Analog input signal is applied to the QA SMA connector, channel QA: • R27 shorted (0Ω) • C30 opened (removed) • R31 opened (removed)
JU4	1-2	QA+ pin connected to the QA SMA through R27.	
JU10	1-2	QA+ pin assumes the DC offset from the analog input source.	
JU3	1-4*	QA- pin connected to pin 6 of transformer T2 through R4.	Differential input, AC-coupled. Single-ended analog input signal is applied to QA SMA connector, channel QA.
JU4	2-3*	QA+ pin connected to pin 4 of transformer T2 through R3.	
JU10	2-3*	IA+ SMA connector to pin 3 of transformer T2 through C67.	
JU3	open	QA- pin DC-coupled to the JU3-2 pin (with JU1–3 as GND) through R4.	Differential input, DC-coupled. Analog input signals are applied to the JU3-2 pin and the JU4-1 pin, channel QA.
JU4	open	QA+ pin DC-coupled to the JU4–1 pin (with JU3-4 as GND) through R3.	
JU10	N/A	QA SMA not used.	

*Default configuration

Table 5. Voltage Reference Modes

REFIN VOLTAGE	REFERENCE MODE
VDD (shunt across jumper JU11)	Internal reference mode. Internal reference voltage equal to 0.512V. Sets the full-scale ADC input to 1.024V _{P-P} and DAC output voltage to 400mV _{P-P} .
External 1.024V (remove shunt from jumper JU11)	Buffered external reference mode. ADC full-scale input voltage set to REFIN. DAC full-scale output voltage proportional to REFIN.

Loopback Test

The MAX586x EV kit circuit provides the J1 and J2 headers that, when configured, connects the ADC digital output bus to the DAC digital input. This allows a preliminary evaluation of the AFEs’ using analog input signals only.

Note: Configuring this way, the J1 header supplies an 8-bit output pattern while the J2 header takes a 10-bit input, resulting in a loss of the DAC performance. Install shunts across the J2 pin headers to connect the DA7 output bit to the DD9 input bit, DA6 output bit to the DD8 input bit, etc. The maximum frequency for the ADC output loopback to DAC input is 25MHz. The maximum frequency for the ADC output loopback DAC input can be increased to 30MHz by changing resistors R37 through R44 to 25Ω.

TDD Mode

A time-division duplex (TDD) operating mode can also be implemented by connecting the ADC digital output to the DAC digital input bus. Use the MAX586x EV kit software to switch between receive and transmit mode to implement TDD mode. Operating in this configuration, the ADC digital buffer (U5) is bypassed. Avoid excessive digital

ground currents by keeping the digital bus capacitance to a minimum in this mode. Refer to the *FDD and TDD Modes* section in the AFE data sheet for further details.

Evaluating the AFEs’

The MAX586x EV kit can be used to evaluate any of the MAX5863, MAX5864, MAX5865, or MAX5866 parts which are all pin and function compatible between one another. The MAX5863 operates at clock frequencies of >2MHz, but ≤7.5MHz. The MAX5864 operates at clock frequencies >7.5MHz, but ≤22MHz. The MAX5865 operates with clock frequencies between 22MHz and 40MHz and the MAX5866 operates with clock frequencies from 40MHz up to 60MHz. Refer to the respective data sheet for detailed technical information.

Board Layout

The MAX586x EV kit is a four-layer board design optimized for high-speed signals. All high-speed signal lines are routed through 50Ω impedance-matched transmission lines. The length of these 50Ω transmission lines is matched to within 40 mils (1mm) to minimize layout-dependent data skew. The board layout separates the digital and analog ground plane of the circuit for optimum performance.

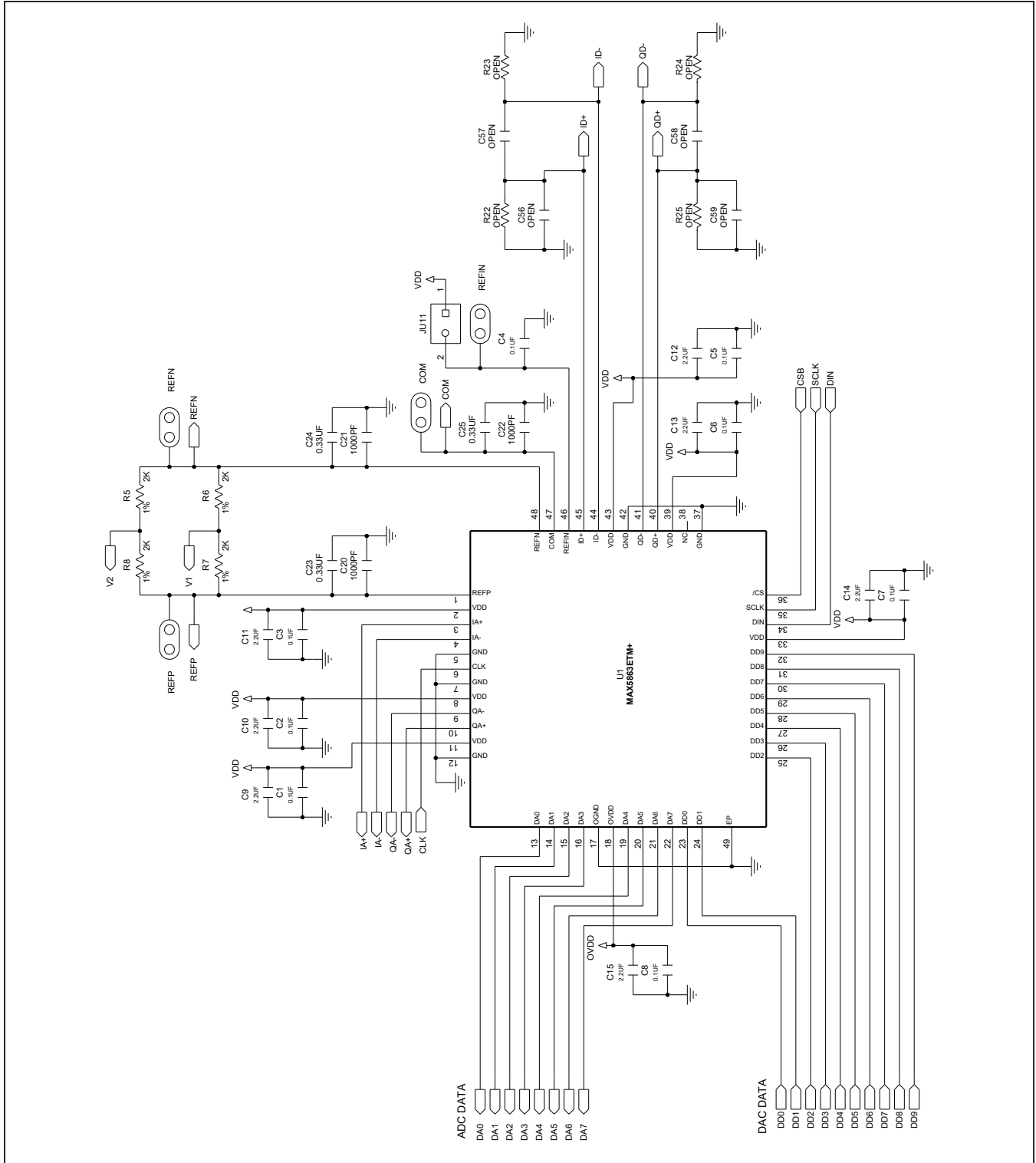

Figure 2. MAX586x EV Kit Schematic (Sheet 1 of 5)

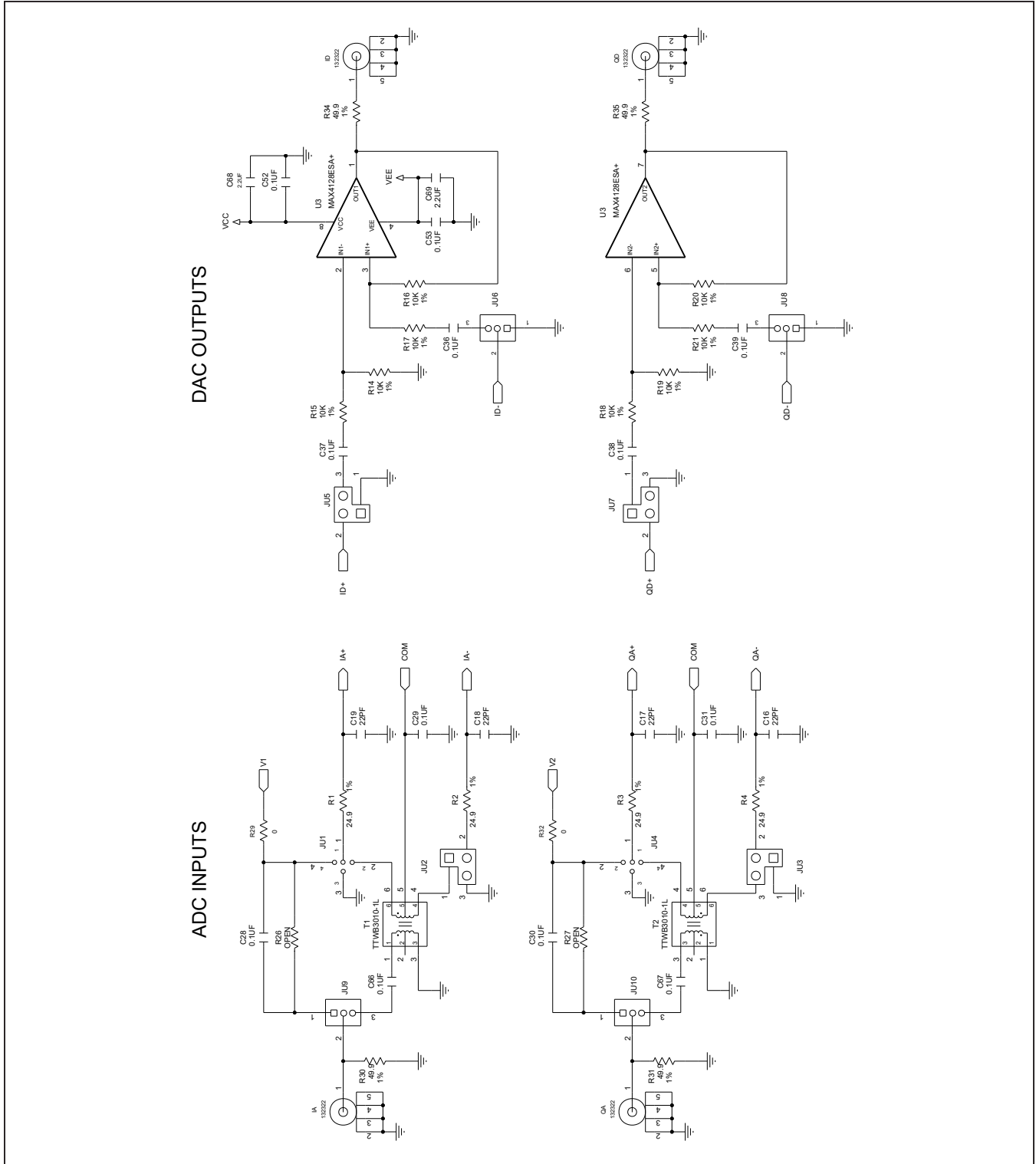

Figure 3. MAX586x EV Kit Schematic (Sheet 2 of 5)

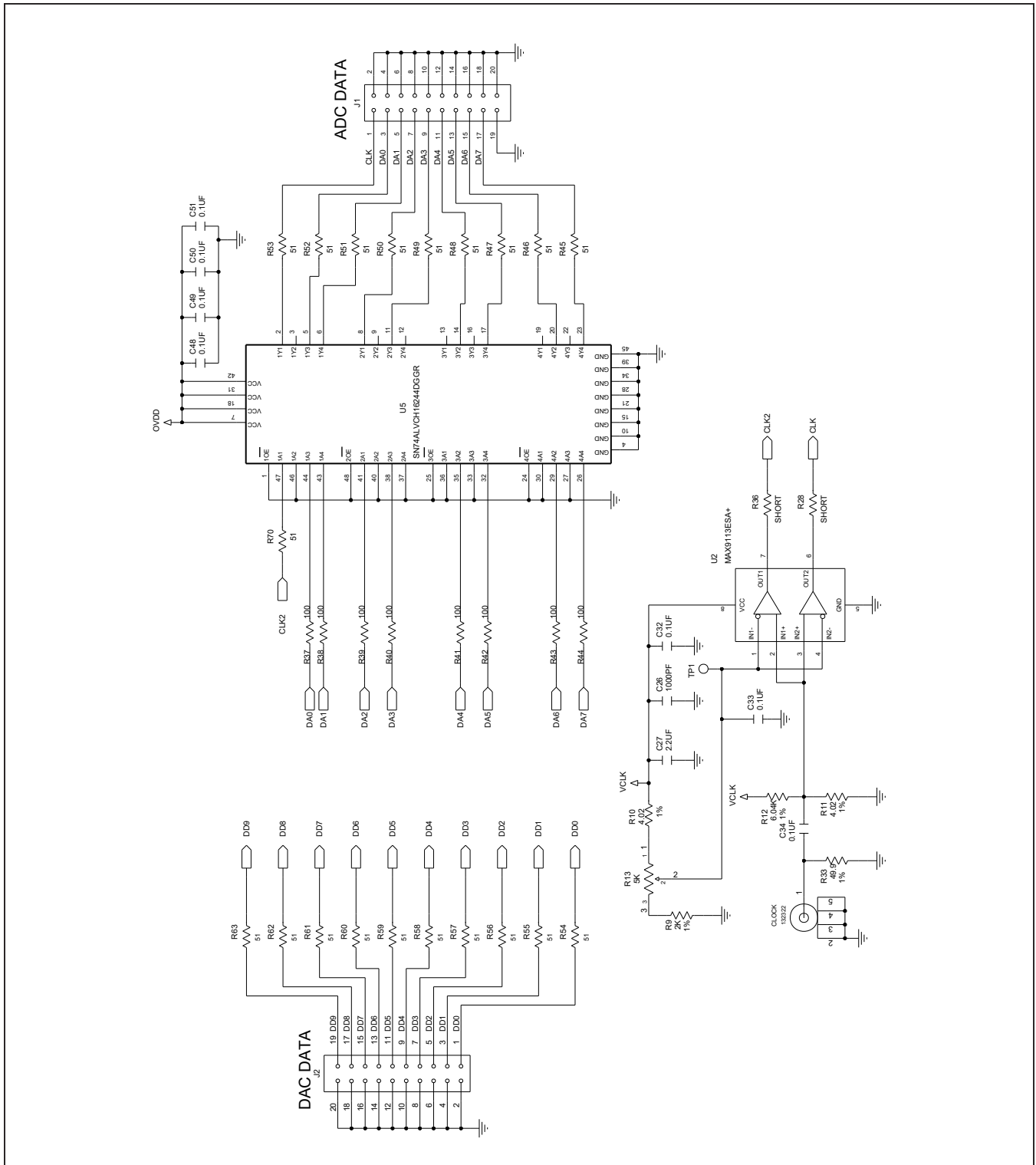

Figure 4. MAX586x EV Kit Schematic (Sheet 3 of 5)

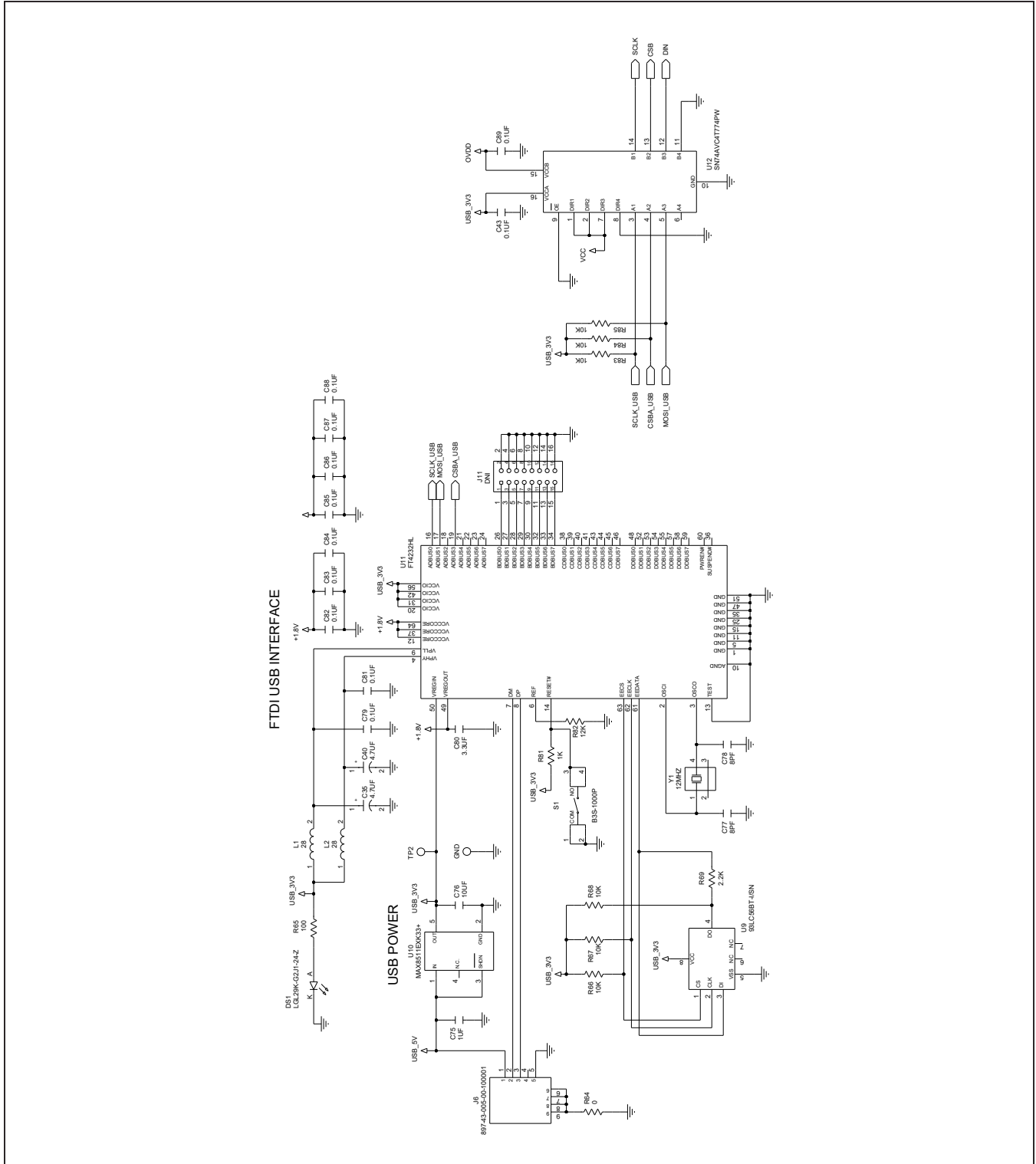

Figure 5. MAX586x EV Kit Schematic (Sheet 4 of 5)

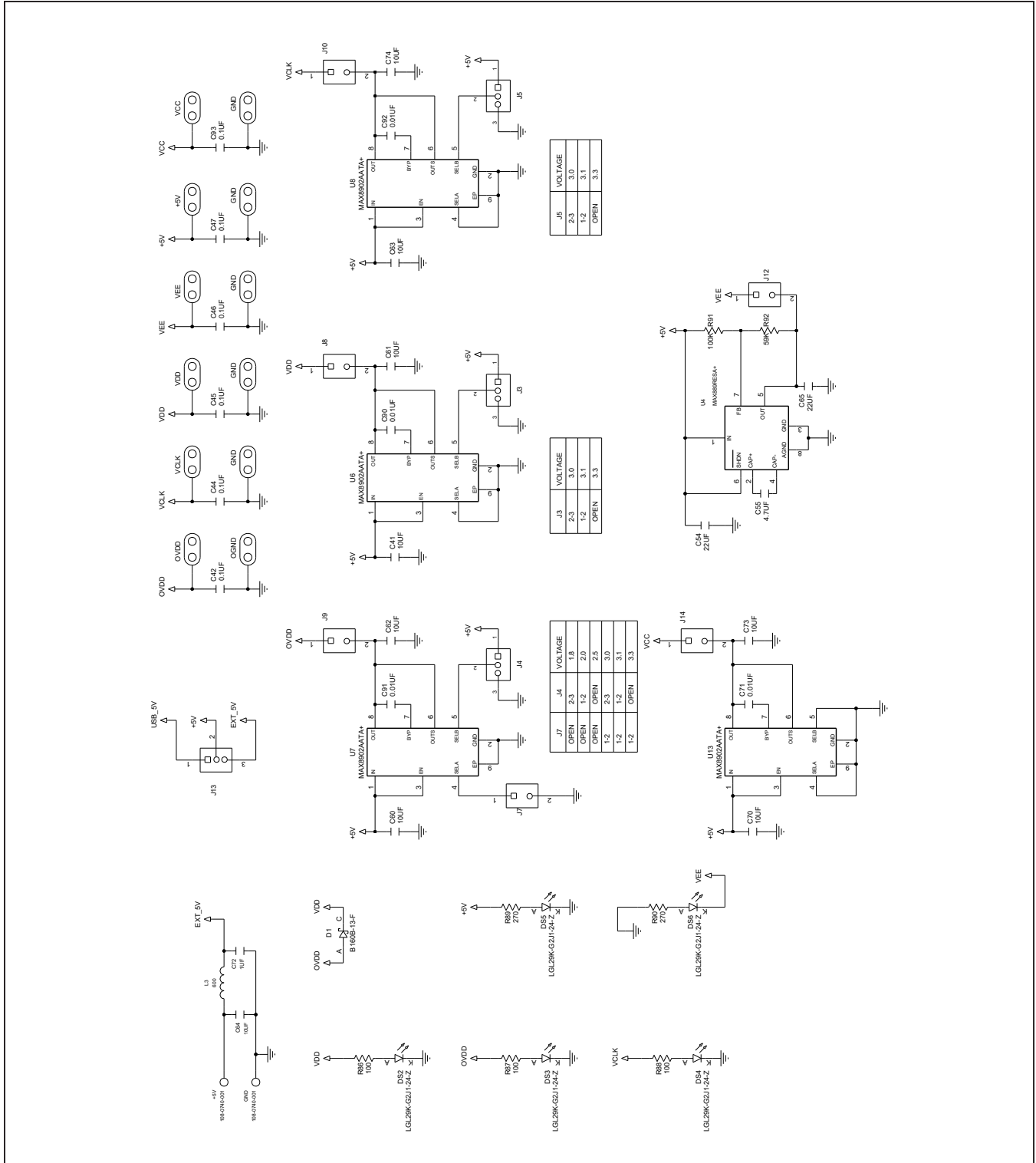

Figure 6. MAX586x EV Kit Schematic (Sheet 5 of 5)

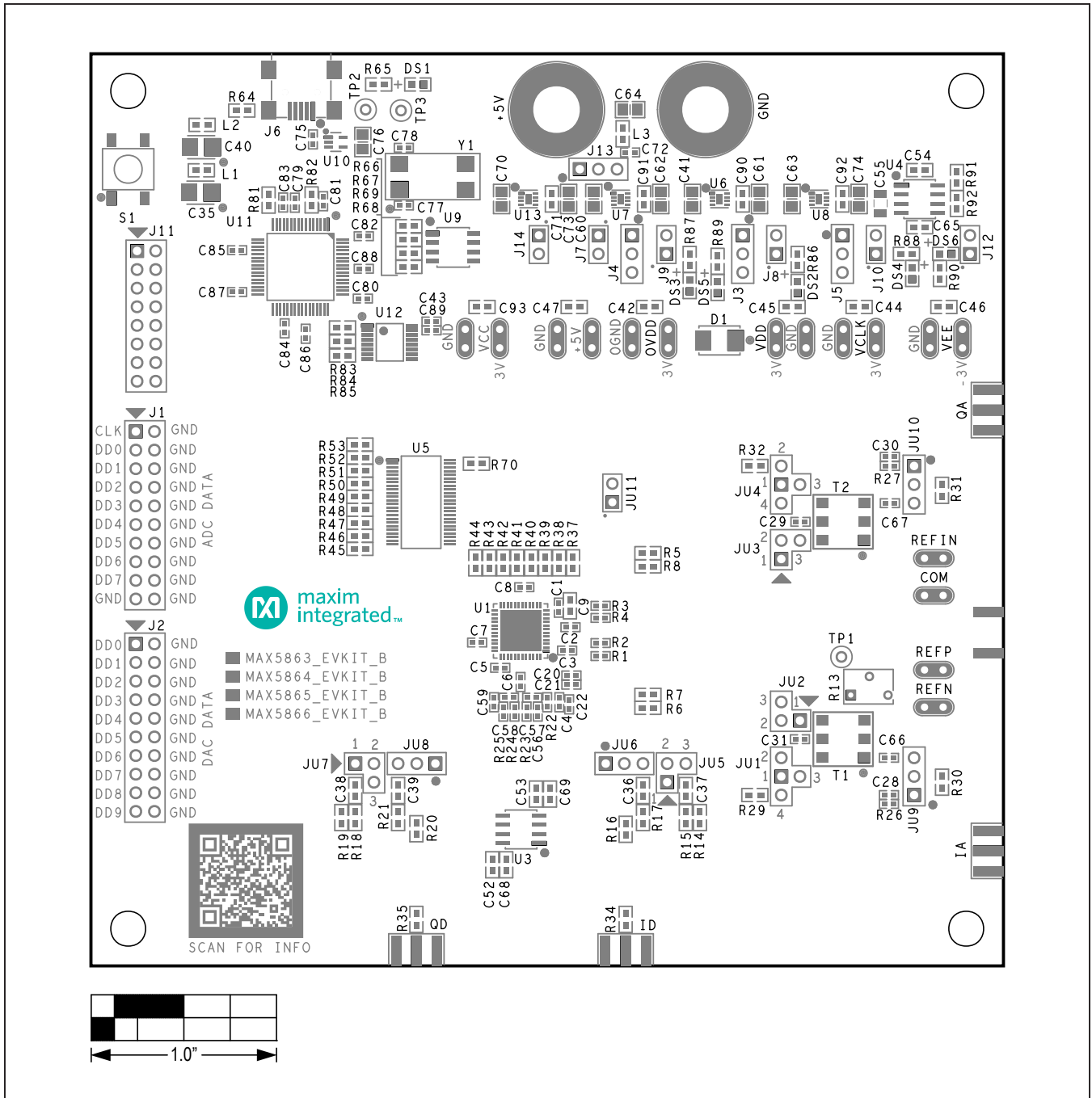

Figure 7. MAX586x EV Kit PC Board Layout—Component Side

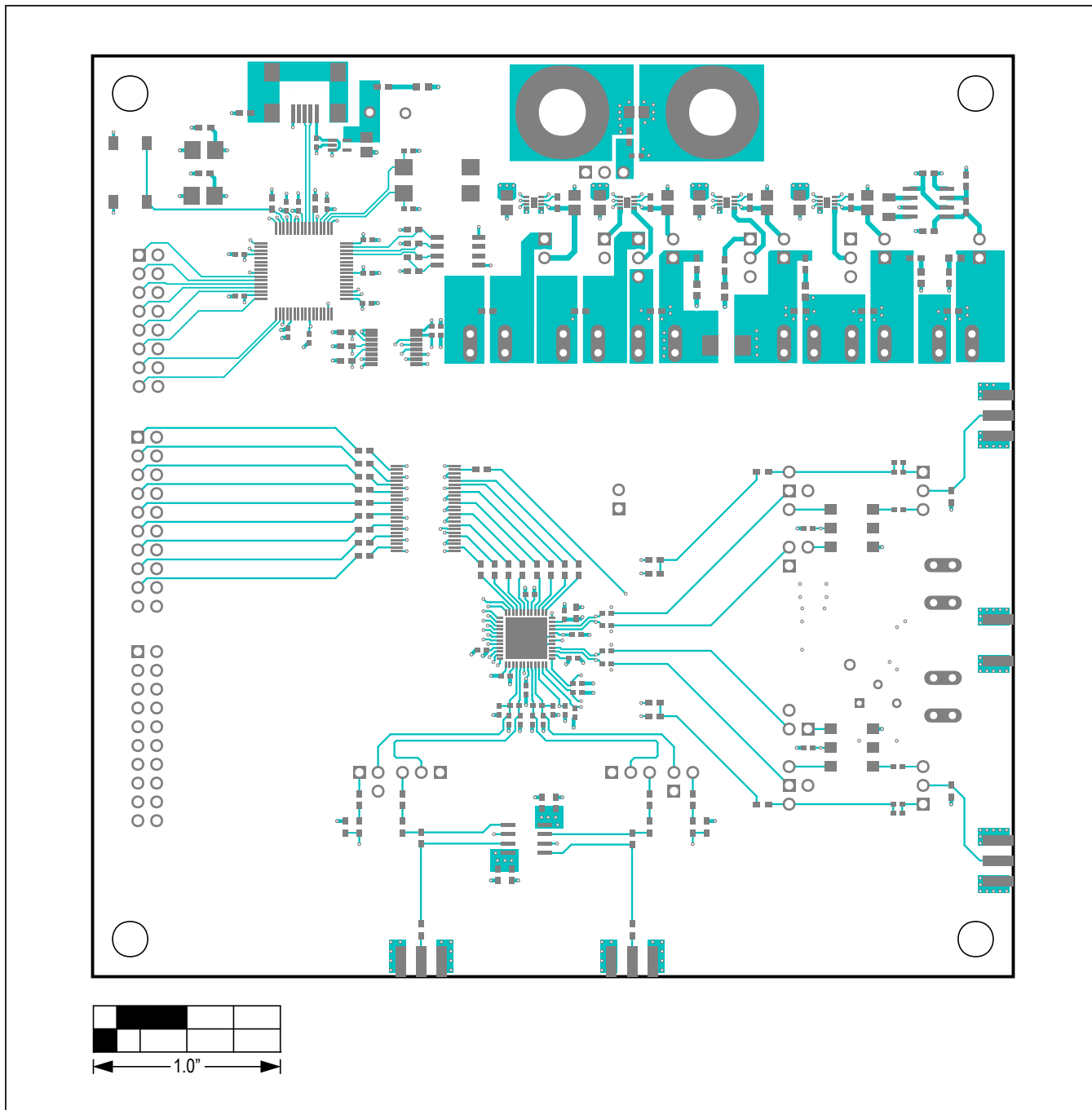

Figure 8. MAX586x EV Kit PC Board Layout—Component Side

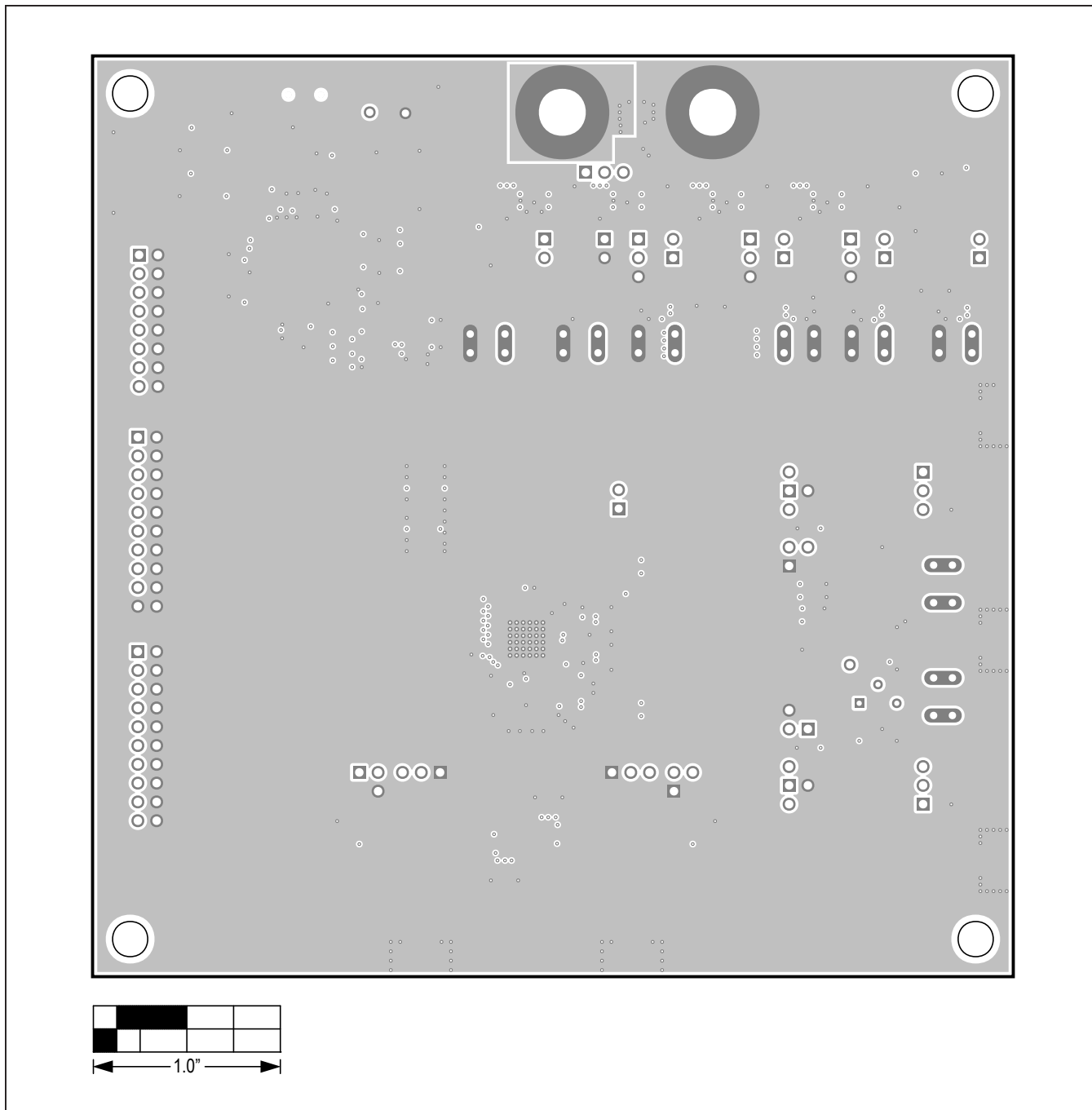

Figure 9. MAX586x EV Kit PC Board Layout—Ground Planes

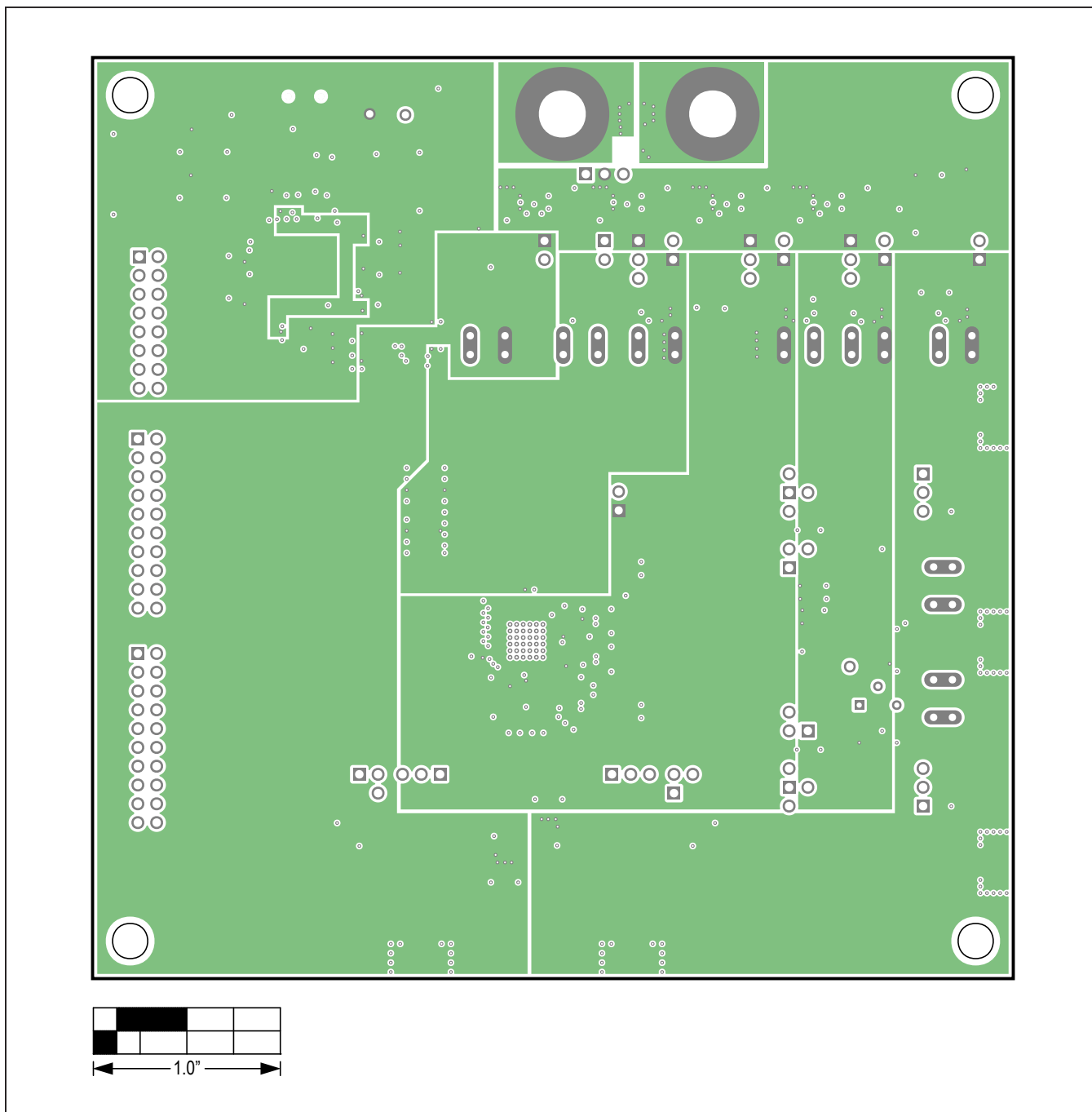

Figure 10. MAX586x EV Kit PC Board Layout—Power Planes

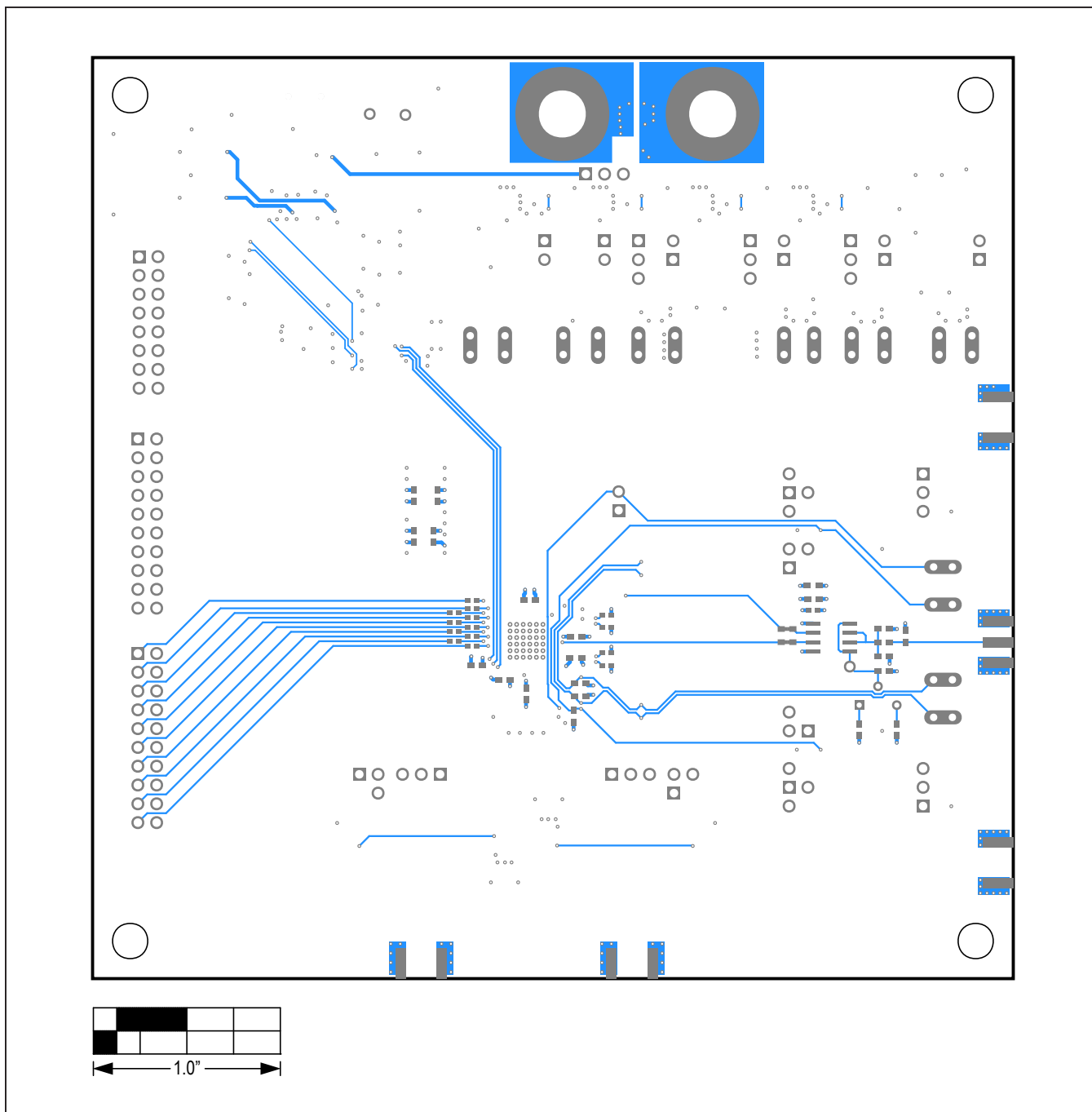

Figure 11. MAX586x EV Kit PC Board Layout—Solder Side

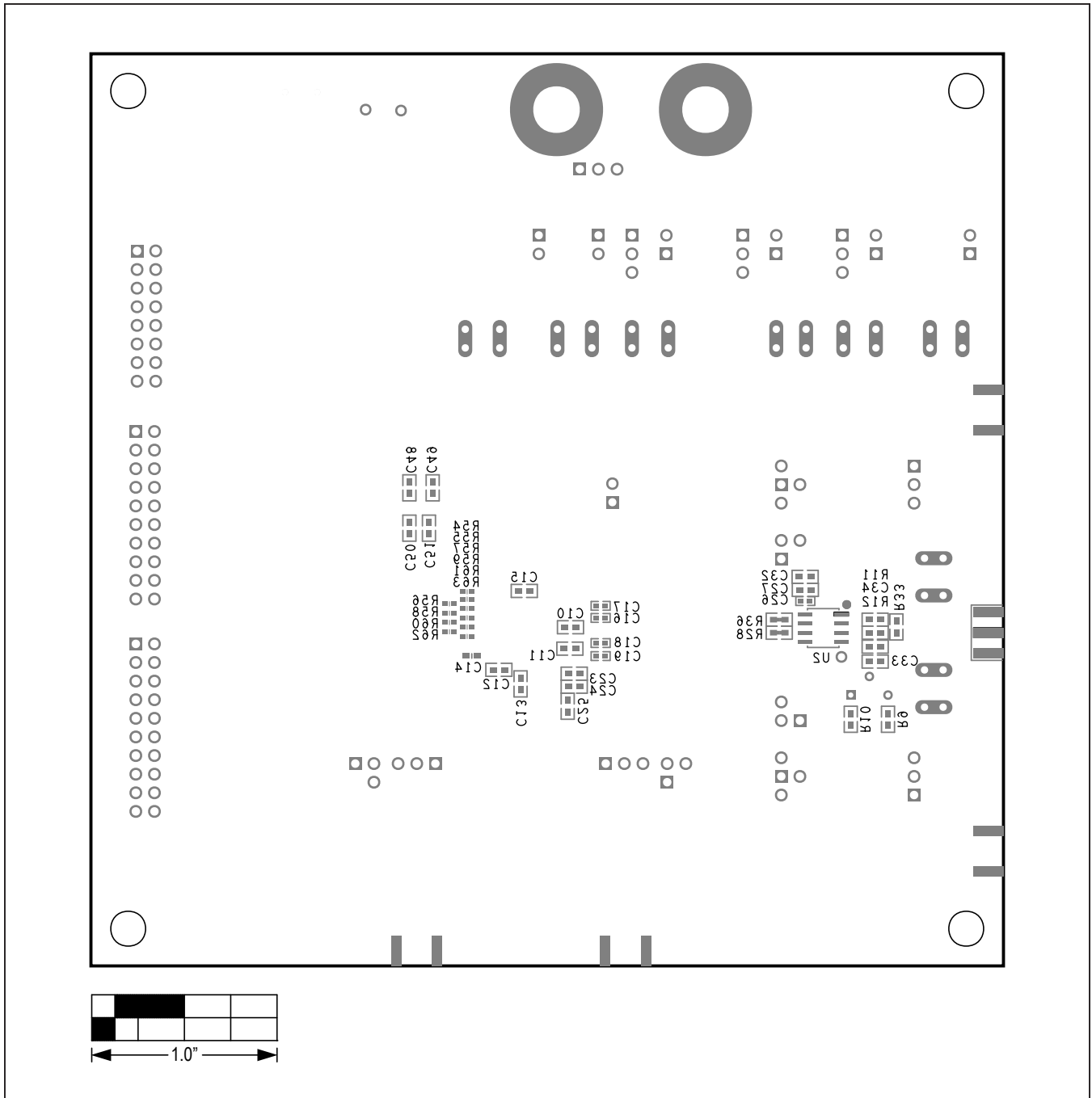

Figure 12. MAX586x EV Kit Component Placement Guide—Solder Side

Revision History

REVISION NUMBER	REVISION DATE	DESCRIPTION	PAGES CHANGED
2	1/21	Updated the entire EV Kit.	1–19
3	3/21	Updated <i>Ordering Information</i> footer with ROHS compliance, Updated the part numbers from MAX5865 to MAX586x, Updated <i>Component List</i> , Updated <i>MAX586x EV Kit Software Files</i> , Updated <i>Procedure</i> section, Updated figure 1, Updated <i>Detailed Description of Hardware</i> section, Updated <i>Power Supplies</i> section, Updated <i>Transmit Dual 10-Bit DAC Input</i> section, and Updated <i>Transmit Dual 10-Bit DAC Input</i> section.	1, 4–8, 11–22

For pricing, delivery, and ordering information, please visit Maxim Integrated's online storefront at <https://www.maximintegrated.com/en/storefront/storefront.html>.

Maxim Integrated cannot assume responsibility for use of any circuitry other than circuitry entirely embodied in a Maxim Integrated product. No circuit patent licenses are implied. Maxim Integrated reserves the right to change the circuitry and specifications without notice at any time.