

MAXIM

MAX5919A Evaluation Kit

General Description

The MAX5919A evaluation kit (EV kit) is a fully assembled and tested surface-mount dual hot-swap controller circuit board that provides current-limiting and VariableSpeed/BiLevel™ fault protection. The circuit uses a MAX5919A IC in a 16-pin QSOP package and is configurable for a 1.0V to 13.2V input range. The MAX5919A features autoretry and output undervoltage and overvoltage monitoring.

The EV kit is configured for 5V and 1.8V inputs. Both inputs are configured for up to 10A of output current. The MAX5919A controls two N-channel MOSFETs and provides current regulation during startup for both inputs. Several configurations allow the MAX5919A IC's unique current-regulation architecture to be tailored to the application. The current-limiting and short-circuit protection features are configurable and demonstrate the various features of the MAX5919A.

The EV kit features several configurations for the startup timer setting, current limit, and output voltage monitoring. The EV kit also provides independent turn-on delays for the outputs. The EV kit can also be used to evaluate other versions of the MAX5918 or MAX5919 after replacing the MAX5919A.

VariableSpeed/BiLevel is a trademark of Maxim Integrated Products, Inc.

Features

- ◆ **Input Voltage:**
5V, VIN1 (As Configured)
1.8V, VIN2 (As Configured)
- ◆ **Independent ON/OFF Control**
- ◆ **Outputs Configured for 5V and 1.8V**
(Configurable from 1.0V to 13.2V)
- ◆ **Configured to 10A Output Current Capability**
(Both Outputs)
- ◆ **25mV Current Threshold Trip (10A)**
- ◆ **Demonstrates Unique Current Regulation Architecture**
- ◆ **Configurable Startup Timer**
- ◆ **Configurable Current Limits**
- ◆ **Configurable Output Overvoltage and Undervoltage Monitoring (Both Outputs)**
- ◆ **Evaluates MAX5918/MAX5919 with IC Replacement**
- ◆ **Surface-Mount Components**
- ◆ **Fully Assembled and Tested**

Ordering Information

| PART | TEMP RANGE | IC PACKAGE |
|---------------|--------------|------------|
| MAX5919AEVKIT | 0°C to +70°C | 16 QSOP |

Note: To evaluate other versions of the MAX5918 and MAX5919, request the desired free sample IC with the MAX5919A EV kit.

Component List

| DESIGNATION | QTY | DESCRIPTION |
|--------------------|-----|--|
| C1, C2, C6, C9 | 4 | 0.1µF ±10%, 50V X7R ceramic capacitors (0805) TDK C2012X7R1H104KT |
| C3, C4 | 2 | 1000µF, 16V OS-CON capacitors (H case) Sanyo 16SA1000M |
| C5 | 0 | Not installed capacitor (H case) |
| C7, C8 | 0 | Not installed capacitors (0805) |
| D1, D2 | 2 | 3A, 30V Schottky diodes (M flat) Toshiba CMS02 |
| JU1, JU2, JU6 | 3 | 3-pin headers |
| JU3, JU4, JU5, JU7 | 4 | 2-pin headers |

| DESIGNATION | QTY | DESCRIPTION |
|-------------|-----|--|
| N1, N2 | 2 | 30V 100A N-channel MOSFETs (D ² PAK) Fairchild FDB7045L |
| R1, R2 | 2 | 0.0025Ω ±5%, 1W sense resistors (2512) Dale/Vishay WSL2512 0.0025Ω ±5%, |
| R3, R4 | 2 | 20kΩ ±1% resistors (0805) |
| R5 | 1 | 723kΩ ±0.5% resistor (0805) PWC-PWC0805-723K-D |
| R6, R8 | 2 | 100kΩ ±0.5% resistors (0805) IRC PFC-W0805R-02-100K-D |

MAX5919A Evaluation Kit

Component List (continued)

| DESIGNATION | QTY | DESCRIPTION |
|-------------|-----|--|
| R7 | 1 | 196k Ω \pm 0.5% resistor (0805) IRC PFC-W0805R-02-196K-D |
| R9, R15 | 2 | 1k Ω \pm 5% resistors (0805) |
| R10, R14 | 2 | 100k Ω \pm 1% resistors (0805) |
| R11 | 1 | 4.02k Ω \pm 1% resistor (0805) |
| R12 | 1 | 7.87k Ω \pm 1% resistor (0805) |
| R13 | 1 | 402k Ω \pm 1% resistor (0805) |
| R16 | 1 | 80.6k Ω \pm 1% resistor (0805) |
| R17, R18 | 2 | 10.0k Ω \pm 5% resistors (0805) |

| DESIGNATION | QTY | DESCRIPTION |
|---|-----|----------------------------|
| SW1, SW2 | 2 | SPST switches |
| U1 | 1 | MAX5919AEEE (16-pin QSOP) |
| VIN1, PGND, VIN2, PGND, VOUT1, PGND, VOUT2, PGND | 8 | Uninsulated banana jacks |
| None | 7 | Shunts (JU1–JU7) |
| None | 1 | MAX5918/MAX5919 data sheet |
| None | 1 | MAX5919A EV kit data sheet |

Component Suppliers

| SUPPLIER | PHONE | FAX | WEBSITE |
|-------------|--------------|--------------|-----------------------|
| Dale/Vishay | 402-564-3131 | 402-563-6296 | www.vishay.com |
| Fairchild | 888-522-5372 | — | www.fairchildsemi.com |
| IRC | 361-992-7900 | 361-992-3377 | www.irctt.com |
| Sanyo USA | 619-661-6322 | 619-661-1055 | www.sanyovideo.com |
| TDK | 847-803-6100 | 847-390-4405 | www.component.tdk.com |
| Toshiba | 949-455-2000 | 949-859-3963 | www.toshiba.com |

Note: Please indicate that you are using the MAX5919A when contacting these component suppliers.

Quick Start

The MAX5919A EV kit is fully assembled and tested. Follow these steps to verify board operation. **Do not turn on the power supply until all connections are completed.**

MAX5919A Configuration 5V and 1.8V, 10A Outputs

- Verify that shunts are on pins 2 and 3 of jumpers JU1 (MON1) and JU2 (MON2).
- Verify that shunts are on jumpers JU3 (LIM1, 10A) and JU4 (LIM2, 10A).
- Verify that shunts are on pins 2 and 3 of jumper JU6 (TIM, 800 μ s).
- Verify that a shunt is not installed on jumpers JU5 and JU7 (no turn-on delay).
- Utilizing very short 10A-rated banana leads (<6in long)**, connect the 5V and 1.8V DC power supplies to the VIN1 and VIN2 banana jacks, respectively. **Utilizing very short 10A-rated banana leads (<6in long)**, connect the supply grounds to the PGND banana jacks.
- Connect a voltmeter to the VOUT1 and PGND pads.
- Turn on both power supplies and verify that the voltage at VOUT1 is 5V.
- Verify that the voltage at VOUT2 is 1.8V.
- Pressing push-button SW1 or SW2 resets the 5V or 1.8V outputs, respectively.
- Test points TP1 and TP2 are provided to observe the MOSFET gate voltage (N1, N2) with an oscilloscope.

Note: The banana leads connecting the power supply and the load to the EV kit must be very short (<6in long) and rated for at least 10A of current.

Detailed Description

The MAX5919A EV kit is a dual hot-swap controller circuit board configured for a 5V input (VIN1, left side) and 1.8V input (VIN2, right side). Both inputs have separate and independent current limiting and VariableSpeed/BiLevel fault protection. The EV kit uses a MAX5919AEEE IC in a 16-pin QSOP package to control both sides of the circuit. The EV kit can be reconfigured for any input voltage between 1.0V to 13.2V, given that at least one input voltage is \geq 2.7V.

MAX5919A Evaluation Kit

Evaluates: MAX5918A/MAX5918L/MAX5919A/MAX5919L

The MAX5919A controls the 5V side N-channel MOSFET (N1) and provides current regulation during startup. The current-limit threshold level can be reconfigured for up to 12A by using jumper JU3. The 5V output voltage monitoring can be disabled by jumper JU1. PC board pads are provided for an external capacitor (C7) to increase the MOSFET (N1) gate turn-on time. Test point TP1 can be used with an oscilloscope to view the gate voltage.

The MAX5919A controls the 1.8V side N-channel MOSFET (N2) and provides current regulation during startup. The current-limit threshold level can be reconfigured for up to 12A by using jumper JU4. The 1.8V output voltage monitoring can be disabled by jumper JU2. PC board pads are provided for an external capacitor (C8) to increase the MOSFET (N2) gate turn-on time. Test point TP2 can be used with an oscilloscope to view the gate voltage.

Three configurable startup timer settings (JU6) and a configurable power-on delay capacitor at each ON pin input (C6, C9) provide several choices for evaluating different hot-swap methods. The MAX5919A's open-drain PGOOD1 and PGOOD2 pin signals are provided at the respective pad on the EV kit. Resistors R17 and R18 pull up the PGOOD1 and PGOOD2 pads, respectively, to the voltage connected at the V_PULL pad. The voltage source connected to V_PULL and GND must not exceed 13.2V maximum. Additionally, the MAX5919A EV kit can be used to evaluate outputs up to 20A. Resistors R1–R4 and MOSFETs N1 and N2 must be appropriately chosen for the higher current levels. Diodes D1 and D2 on the EV kit are used to prevent an inductive kickback resulting from long lead connections in a lab environment. The diodes are not generally needed in a real application circuit. To evaluate a MAX5918, order the desired IC from Maxim's samples department and replace the MAX5919 with the MAX5918.

Jumper Selection

Several jumper selections in Tables 1–7 display the functions provided by the MAX5919A EV kit.

5V Output Voltage Monitoring (VOUT1)

The MAX5919A EV kit features an overvoltage and undervoltage monitor circuit for the 5V output. The PGOOD1 pad is pulled up to the voltage source connected to the V_PULL pad by resistor R17. If the 5V output voltage is $\geq +12.6\%$ (5.63V typ) or $\leq -11\%$ (4.45V typ), the MAX5919A pulls the PGOOD1 pin low. Jumper JU1 is provided to disable this feature. Table 1 lists the various jumper options.

1.8V Output Voltage Monitoring (VOUT2)

The MAX5919A EV kit features an overvoltage and

undervoltage monitor circuit for the 1.8V output. The PGOOD2 pad is pulled up to the voltage source connected to the V_PULL pad by resistor R18. If the 1.8V output voltage is $\geq +12.6\%$ (2.03V typ) or $\leq -11\%$ (1.60V typ), the MAX5919A pulls the PGOOD2 pin low. Jumper JU2 is provided to disable this feature. Table 2 lists the various jumper options.

5V Slow-Comparator Current Limit (VOUT1)

The MAX5919A EV kit features a 2-pin jumper (JU3) to change the slow-comparator current-limit threshold level for the 5V output. Table 3 lists the jumper options.

1.8V Slow-Comparator Current Limit (VOUT2)

The MAX5919A EV kit features a 2-pin jumper (JU4) to change the slow-comparator current-limit threshold level for the 1.8V output. Table 4 lists the jumper options.

Startup Timer Setting

The MAX5919A EV kit features several choices for setting the time limit to completely turn on the MOSFETs (N1, N2). Jumper JU6 selects the time and Table 5 lists the selectable jumper options to reconfigure the startup timer setting.

ON1 PIN Delay (VIN1)

The MAX5919A EV kit features a jumper to delay turning on the VOUT1 output. Given that the power is valid on VIN1 for more than the UVLO-to-startup delay (37.5ms typ), the jumper sets the response of the MAX5919A ON1 pin. Jumper JU7 selects the turn-on delay for the EV kit. Table 6 lists the selectable jumper options.

ON2 PIN Delay (VIN2)

The MAX5919A EV kit features a jumper to delay turning on the VOUT2 output. Given that the power is valid on VIN2 for more than the UVLO-to-startup delay (37.5ms typ), the jumper sets the response of the MAX5919A ON2 pin. Jumper JU5 selects the turn-on delay for the EV kit. Table 7 lists the selectable jumper options.

Control Modes and Other Input Voltages

Fault Resetting

The MAX5919A EV kit features two push-button switches (SW1, SW2) to allow momentary toggling of the ON1 and ON2 pins of the MAX5919A IC. Each switch disables the respective EV kit output or unlatch faults when MAX5918L or MAX5919L has been installed on the EV kit. An external controller can be utilized to control the respective ON pin of the MAX5919A EV kit. Refer to the MAX5918/MAX5919 data sheet for additional functions of the ON1 or ON2 pin when toggling or applying a voltage to it.

MAX5919A Evaluation Kit

Table 1. Jumper JU1 Functions

| SHUNT LOCATION | MON1 PIN | EV KIT MODE |
|----------------|-------------------------------|---|
| 1 and 2 | Connected to VIN1 | Disable monitoring output voltage VOUT1 |
| 2 and 3 | Connected to VOUT1 through R5 | Monitor output voltage VOUT1 |

Table 2. Jumper JU2 Functions

| SHUNT LOCATION | MON2 PIN | EV KIT MODE |
|----------------|-------------------------------|---|
| 1 and 2 | Connected to VIN2 | Disable monitoring output voltage VOUT2 |
| 2 and 3 | Connected to VOUT2 through R7 | Monitor output voltage VOUT2 |

Table 3. Jumper JU3 Functions

| SHUNT LOCATION | LIM1 PIN | EV KIT MODE |
|----------------|------------------|--|
| Installed | Connected to GND | Slow-comparator current limit set to 25mV (10A trip) VOUT1 |
| None | Connected to R3 | Slow-comparator current limit set to 30mV (12A trip) VOUT1 |

Table 4. Jumper JU4 Functions

| SHUNT LOCATION | LIM2 PIN | EV KIT MODE |
|----------------|------------------|--|
| Installed | Connected to GND | Slow-comparator current limit set to 25mV (10A trip) VOUT2 |
| None | Connected to R4 | Slow-comparator current limit set to 30mV (12A trip) VOUT2 |

Table 5. Jumper JU6 Functions

| SHUNT LOCATION | TIM PIN | EV KIT MODE |
|----------------|----------------------|-----------------------------------|
| 1 and 2 | TIM connected to R11 | 400 μ s startup timer setting |
| 2 and 3 | TIM connected to R12 | 800 μ s startup timer setting |
| None | TIM floating | 9ms startup timer setting |

Table 6. Jumper JU7 Functions

| SHUNT LOCATION | ON1 PIN, R13, R14 | EV KIT MODE |
|----------------|---------------------------------------|---|
| None | C6 floating | VOUT1 turns on with no delay |
| Installed | Connected to C6, enable turn-on delay | VOUT1 turns on 16.8ms after releasing SW1 |

Table 7. Jumper JU5 Functions

| SHUNT LOCATION | ON2 PIN, R10, R16 | EV KIT MODE |
|----------------|---------------------------------------|--|
| None | C9 floating | VOUT2 turns on with no delay |
| Installed | Connected to C9, enable turn-on delay | VOUT2 turns on 9.3ms after releasing SW2 |

MAX5919A Evaluation Kit

Evaluates: MAX5918A/MAX5918L/MAX5919A/MAX5919L

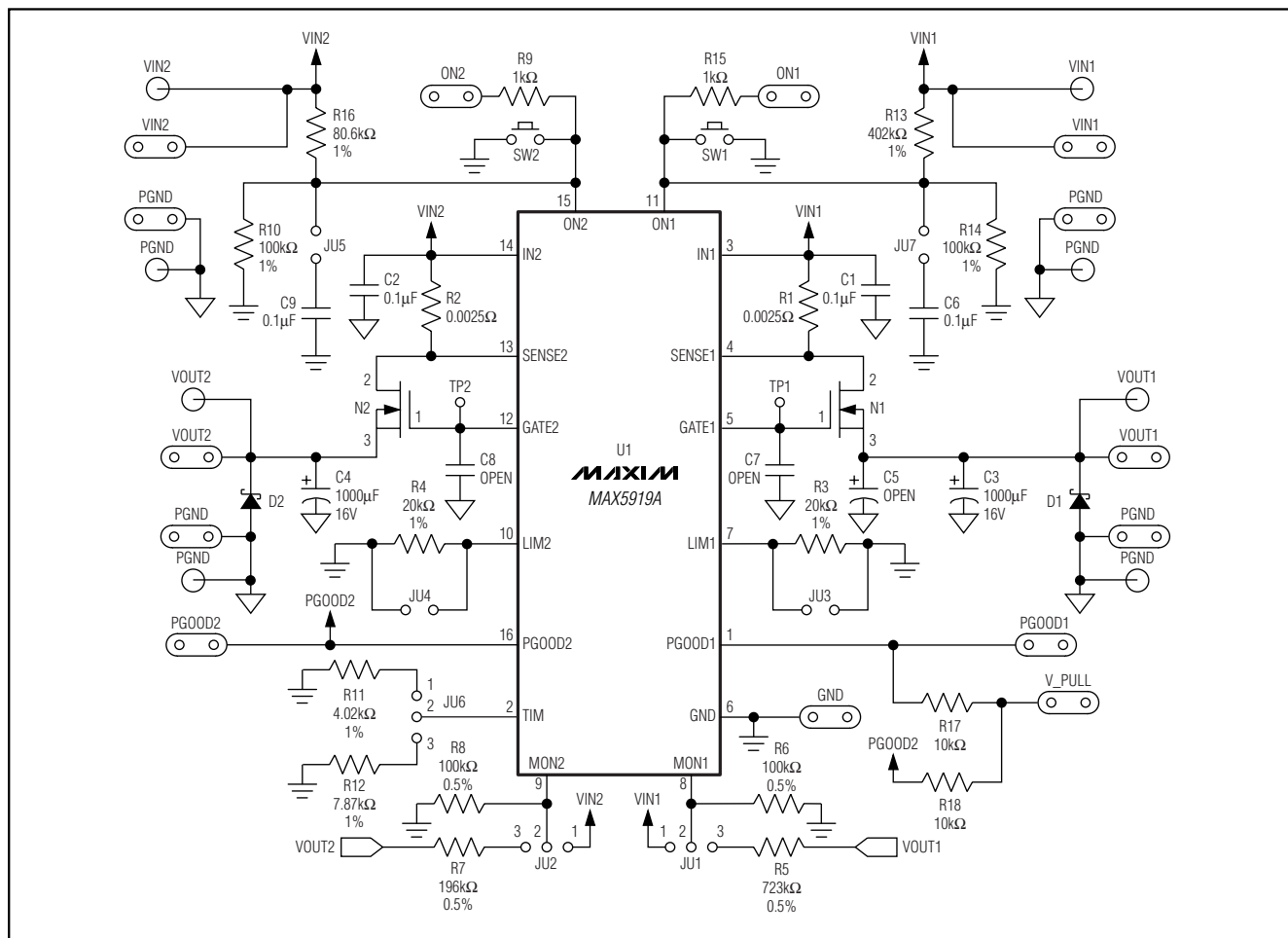

Figure 1. MAX5919A EV Kit Schematic

MOSFET Gate Control

The MAX5919A EV kit features an option to increase the MOSFET gate (N1, N2) turn-on time. PC board pads are provided for installing a capacitor (C7, C8) to the respective gate-drive pins. Refer to the MAX5918/MAX5919 data sheet *Startup Sequence* section for information on selecting the value of the capacitors. Test points TP1 and TP2 are provided to observe the gate-drive voltage with an oscilloscope.

Evaluating Other Input Voltages (1V to 13.2V) and Other Output Currents

The MAX5919A EV kit can evaluate other dual hot-swap controller configuration voltages operating from 1V up to 13.2V and can provide up to 20A of current at the output. The output voltage monitoring resistors (R5, R6, and/or R7, R8) must also be replaced to provide 0.610V at the MON1 and/or MON2 pin at nominal output voltages,

respectively. One of the input voltages (VIN1, VIN2) must be $\geq 2.7V$. To evaluate other current limits, resistors R1–R4 and MOSFETs N1 and N2 must be appropriately chosen for the new current level. Refer to the MAX5918/MAX5919 data sheet for information on selecting components.

Evaluating the MAX5918

Evaluating MAX5918 Dual Hot-Swap Designs

The MAX5919A EV kit can also evaluate a MAX5918 dual hot-swap controller circuit design. Refer to the MAX5918/MAX5919 data sheet for other variations of this product family. The MAX5919A must be removed and replaced by the desired IC. The IC can be ordered from Maxim.

MAX5919A Evaluation Kit

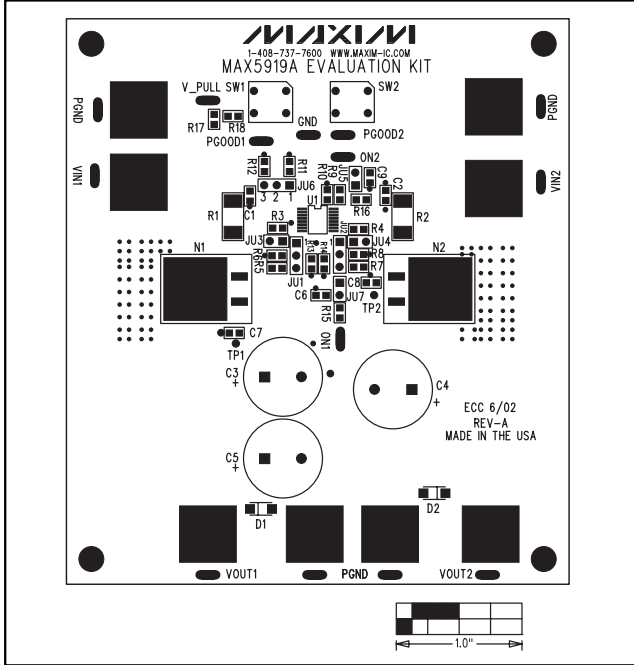

Figure 2. MAX5919A EV Kit Component Placement Guide—Component Side

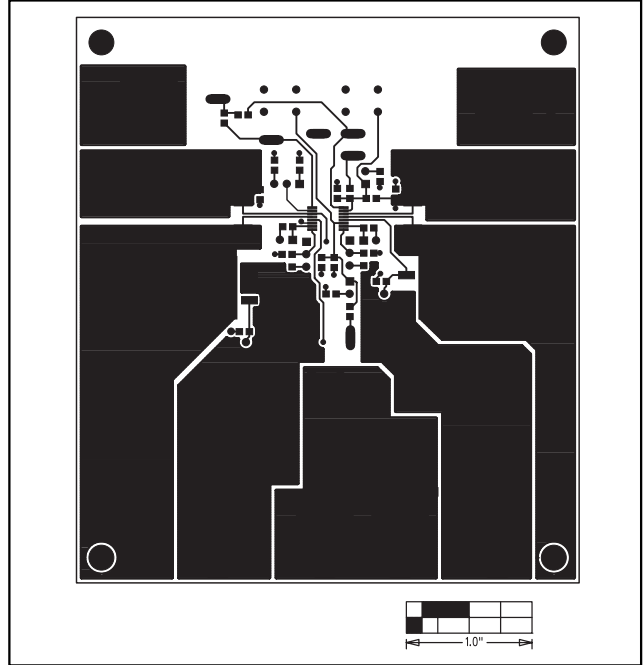

Figure 3. MAX5919A EV Kit PC Board Layout—Component Side

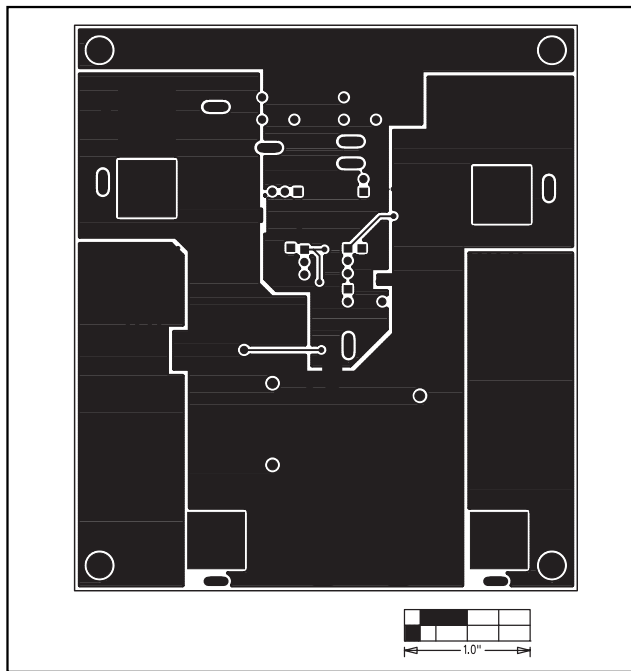

Figure 4. MAX5919A EV Kit PC Board Layout—Solder Side

Maxim cannot assume responsibility for use of any circuitry other than circuitry entirely embodied in a Maxim product. No circuit patent licenses are implied. Maxim reserves the right to change the circuitry and specifications without notice at any time.

6 _____ **Maxim Integrated Products, 120 San Gabriel Drive, Sunnyvale, CA 94086 408-737-7600**