

MAX66903 Evaluation Kit

Evaluates: MAX66100/MAX66120/MAX66140

General Description

The MAX66903 evaluation kit (EV kit) is a fully functional ISO 15693 reader that supports all the mandatory and optional commands in the ISO 15693 protocol. The EV kit also performs a SHA-1 calculation using the on-board microcontroller. SHA-1 is a secure hash algorithm with a challenge-and-response authentication (ISO/IEC 10118-2 SHA-1). This feature was added to support the MAX66140.

The EV kit is complete with an on-board HF antenna, an in-circuit jumper option for an external 50Ω antenna, USB connectivity with parasitic power, and on-board microcontroller with modulation and demodulation circuitry. The EV kit also includes Windows XP®, Windows Vista®, and Windows® 7-compatible software that provides a simple graphical user interface (GUI) that supports the features of the MAX661x0 devices.

Features

- ◆ Fully Functional Low-Cost ISO 15693 Reader
- ◆ SHA-1 Support
- ◆ On-Board HF Antenna
- ◆ External 50Ω Antenna Option
- ◆ USB 2.0 Support
- ◆ Power Provided Through USB
- ◆ External Circuitry for Modulation and Demodulation of the ISO 15693 Frame
- ◆ Windows-Compatible GUI Available for Download
- ◆ Schematics and Firmware Available for Quick Development

[Ordering Information](#) appears at end of data sheet.

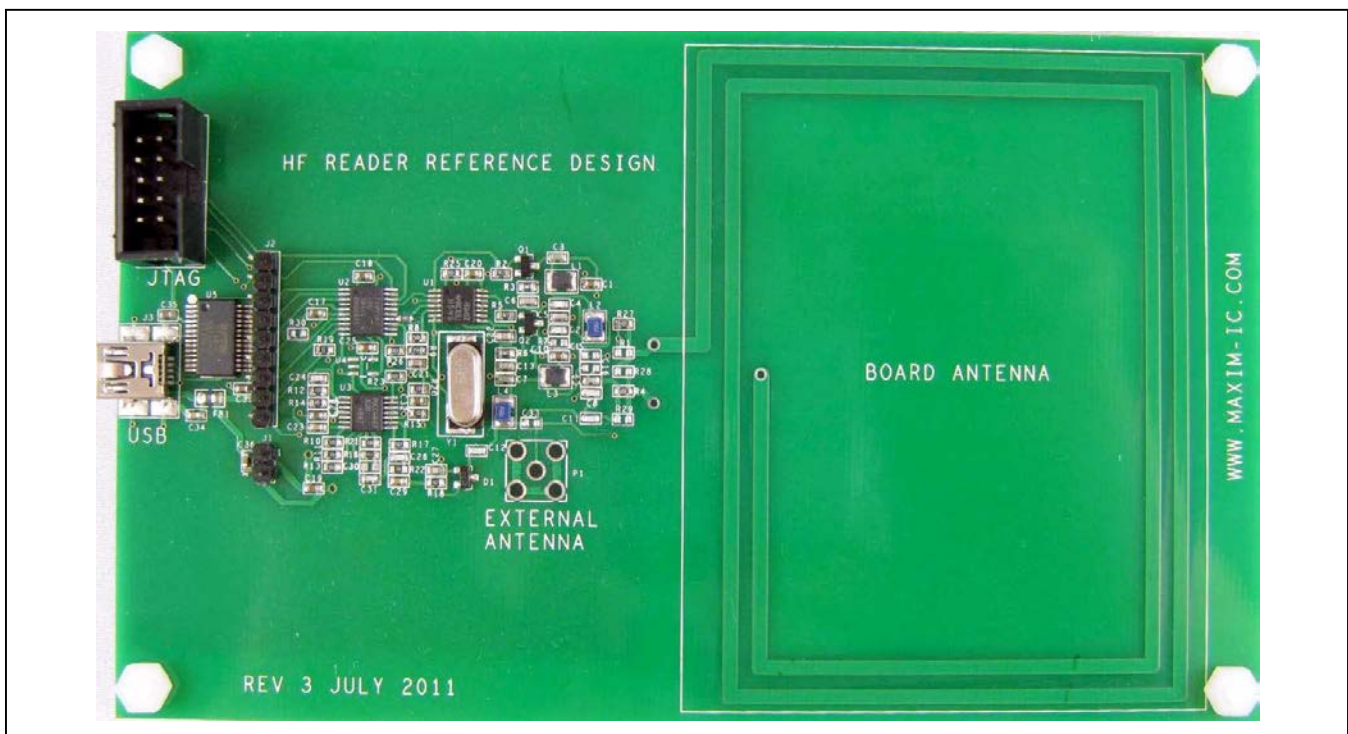

Figure 1. MAX66903 Evaluation Kit

Windows, Windows XP, and Windows Vista are registered trademarks of Microsoft Corp.

For pricing, delivery, and ordering information, please contact Maxim Direct at 1-888-629-4642, or visit Maxim Integrated's website at www.maximintegrated.com.

MAX66903 Evaluation Kit

Evaluates: MAX66100/MAX66120/MAX66140

Component List

DESIGNATION	QTY	DESCRIPTION
C1, C10, C17, C18, C20, C25, C28, C32, C33, C36, C37	11	0.10 μ F, 50V Y5V ceramic capacitors (0603)
C2, C11, C27	3	68pF \pm 5%, 50V C0G ceramic capacitors (0603)
C3, C7	2	91pF 50V C0G ceramic capacitors (0603)
C4, C8	2	180pF \pm 5%, 50V C0G ceramic capacitors (0603)
C5	1	270pF \pm 5%, 50V C0G ceramic capacitor (0603)
C6, C13	2	22pF \pm 5%, 50V C0G ceramic capacitors (0603)
C9	1	270pF \pm 5%, 50V C0G ceramic capacitor (0603)
C12, C24, C26	3	12pF \pm 5%, 50V C0G ceramic capacitors (0603)
C15, C16, C30	2	Capacitors, do not populate
C19, C35	2	0.47 μ F, 50V Y5V ceramic capacitors (0603)
C21, C22	2	18pF \pm 5%, 50V C0G ceramic capacitors (0603)
C23, C29, C34	3	1000pF \pm 10%, 50V X7R ceramic capacitors (0603)
C31	1	110pF \pm 5%, 50V C0G 570 ceramic capacitor (0603)
D1	1	200mA, 70V Schottky diode (SOT23)
FB1	1	220 Ω EMI/RFI suppressor and ferrite (0805)
J1	1	0.100 single-strip 2-position connector header
J2	1	Breakaway 0.100 9-position strip connector header
J3	1	Mini-B USB
L1, L3	2	1.5 μ H \pm 5% RF power inductors

DESIGNATION	QTY	DESCRIPTION
L2, L4	2	0.56 μ H power inductors (1008)
P1	1	Connector plug, do not populate
P10	1	Conn plug 10pos 3a 300v strt dip
Q1, Q2	2	GP npn amp transistors (SOT23)
R1, R29, R28, R30	4	Resistors, do not populate
R2, R5	2	22 Ω \pm 5%, 1/8W SMD resistors (0805)
R3, R6	2	18 Ω \pm 5%, 1/10W SMD resistors (0603)
R4, R27	2	1.40 Ω \pm 1%, 1/10W SMD resistors (0603)
R7, R9, R11, R14, R18, R22	6	1.1k Ω \pm 5%, 1/10W SMD resistors (0603)
R8	1	1.0m Ω \pm 5%, 1/10W SMD resistors (0603)
R10, R12, R15, R17, R20, R21, R23, R25, R26	9	10k Ω \pm 5%, 1/10W SMD resistors (0603)
R13	1	560 Ω \pm 5%, 1/10W SMD resistor (0603)
R16	1	11k Ω \pm 5%, 1/10W \pm 5% SMD resistor (0603)
R19	1	0 Ω 1/4W SMD resistor (1206)
U1	1	Quad 2in pos-nor gate (14 TSSOP) 74AHC02
U2	1	Microcontroller AVR 16kb fl 512b EE 512B RAM 16MHz ind-g ATiny87/167
U3	1	Quad op amp r-r 8MHz (14 TSSOP) Maxim MAX4487AUD
U4	1	Do not populate
U5	1	USB interface , USB-to-serial UART enhanced (28 SSOP) FT232RL
Y1	1	13.560MHz, 18pF SMD crystal

MAX66903 Evaluation Kit

Evaluates: MAX66100/MAX66120/MAX66140

Component Suppliers

SUPPLIER	PHONE	WEBSITE
FTDI	+44 (0) 141-429-2777	www.ftdichip.com
Maxim Integrated Products	408-601-1000	www.maxim-ic.com
Micro Commercial Components	818-701-4933	www.mccsemi.com
Molex Connector	800-786-6539	www.molex.com
Murata	770-436-1300	www.murata-northamerica.com
OMRON	847-882-2288	www.omron.com
Panasonic	800-344-2112	www.panasonic.com
Sullins Connector Solutions	888-774-3100	www.sullinscorp.com
TDK Corporation	847-803-6100	www.component.tdk.com
TE Connectivity	800-522-6752	www.te.com
Texas Instruments	972-644-5580	www.ti.com
Vishay/Dale	402-563-6866	www.vishay.com

Note: Indicate the specific Maxim part number you are using when contacting these component suppliers.

HF Antenna Configuration

The MAX66903 EV kit has two available antenna configurations: internal coil and external 50Ω coax. The EV kit is shipped in the internal coil configuration.

INTERNAL ANTENNA COIL CONFIGURATION	
Populate	L2, L4 = 0.56μH
Do not populate	C15, C16, C33, P1, R7
EXTERNAL 50Ω COAX CONFIGURATION	
Populate	C4 = 0.1μF; L2, L4 = 1.2μH
Do not populate	C2, C5, C8, C9, C11, R1, R4, R27, R28, R29

MAX66903 EV Kit Files

FILE	DESCRIPTION
CDM20814_SETUP.EXE	FTDI installation software
MAXIMHFRFID.APPLICATION.EXE	Application manifest file
SETUP.EXE	Installs the EV kit files on your computer
VISUALBASICPOWERPACKSSETUP.EXE	Visual Basic® Power Pack installation files

Visual Basic is a registered trademark of Microsoft Corp.

MAX66903 Evaluation Kit

Evaluates: MAX66100/MAX66120/MAX66140

Quick Start

Required Equipment

- MAX66903 EV kit (USB cable included)
- User-supplied Windows XP, Windows Vista, or Windows 7 PC with a spare USB port
- MAX66140 ISO card (supplied with EV kit)

Software Installation and Instruction Procedure

Note: In the following sections, software-related items are identified by bolding. Text in **bold** refers to items directly from the EV kit software. Text in **bold and underlined** refers to items from the Windows operating system.

The EV kit is fully assembled and tested. Follow the steps below for proper operation.

- 1) Visit www.maximintegrated.com/evkitsoftware to download the latest version of the kit software, **66903Rxx.ZIP**. Save the file to a temporary folder and uncompress the ZIP file.
- 2) Install the EV kit software on your computer by running the **SETUP.EXE** program inside the temporary folder. The program files are copied and icons are created in the Windows **Start | Programs** menu.
- 3) Install the FTDI USB drivers by running the **CDM20814_SETUP.EXE** program inside the temporary folder.
- 4) Connect the provided Mini-USB cable to the MAX66903 and the PC. A **Building Driver Database** window pops up in addition to **New Hardware Found** message when installing the USB driver for the first time. Administrator privileges are required to install the USB device driver on Windows platforms.
- 5) Run the **MAXIMHFRFID.APPLICATION.EXE** program in the **Start | Programs | MAXHFRFID** menu. If you get an error requesting Microsoft.VisualBasic.PowerPacks, close the **MAXIMHFRFID.APPLICATION.EXE** program and install the **VISUALBASICPOWERPACKSSETUP.EXE** program in the temporary folder. When program has completed the installation, close it and then rerun the **MAXIMHFRFID.APPLICATION.EXE** program.
- 6) When the **MAXIMHFRFID.APPLICATION.EXE** is running, select the COM Port associated with the USB device. See [Figure 2](#).
- 7) Place a MAX66140 ISO card on the on-board antenna and select the **Find Tags** button. See [Figure 3](#).
- 8) Read and display the memory of the tag by pressing the **Read Memory** button. This can only occur if a tag has been found. See [Figure 4](#).
- 9) Load the secret in the **SHA Secret** text box then click the **Load** button.
- 10) Select any page number and click **Authenticate**. If the SHA-1 MAC received is the same as what was calculated, the pass/fail button will be **GREEN**. Otherwise, it will be **RED**. See [Figure 5](#).
- 11) For more information about SHA-1 authentication or the MAX66140, refer to the MAX66140 IC data sheet.

MAX66903 Evaluation Kit

Evaluates: MAX66100/MAX66120/MAX66140

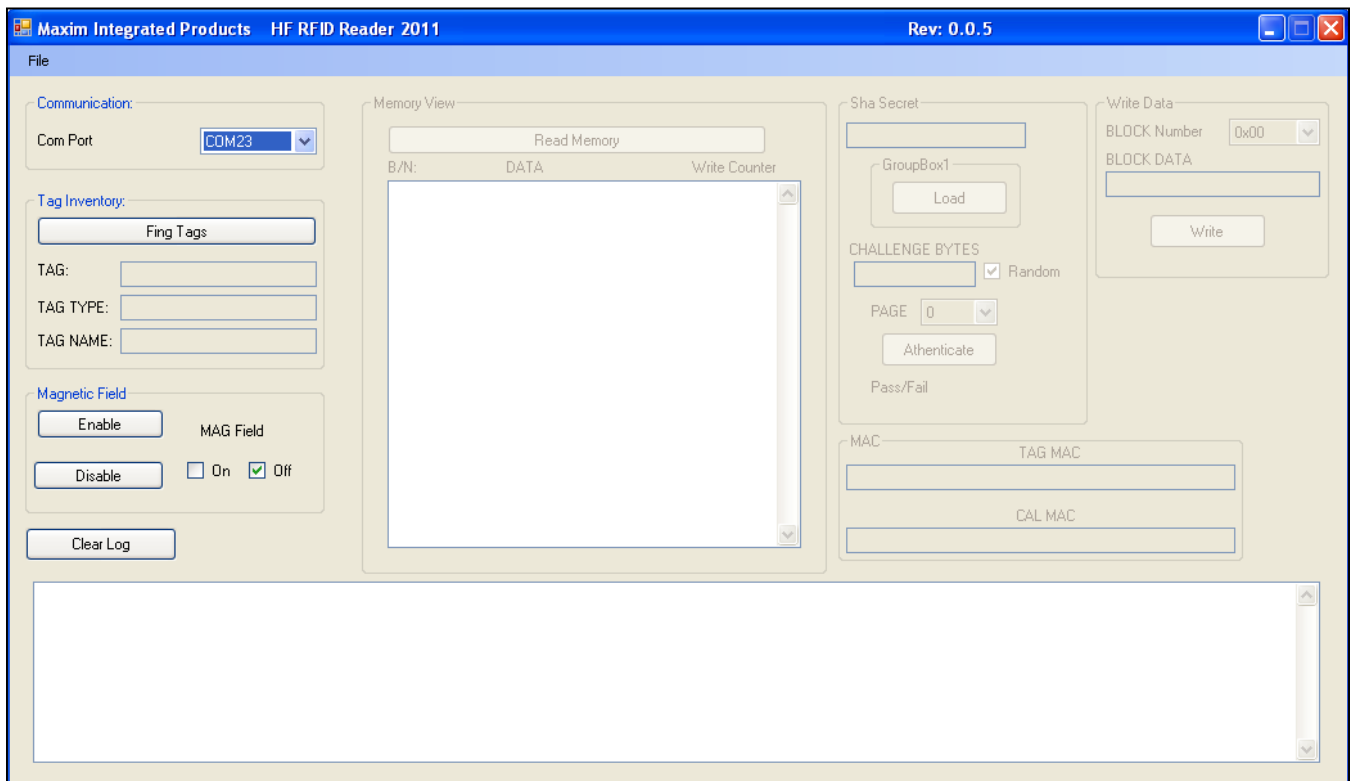

Figure 2. Select Com Port

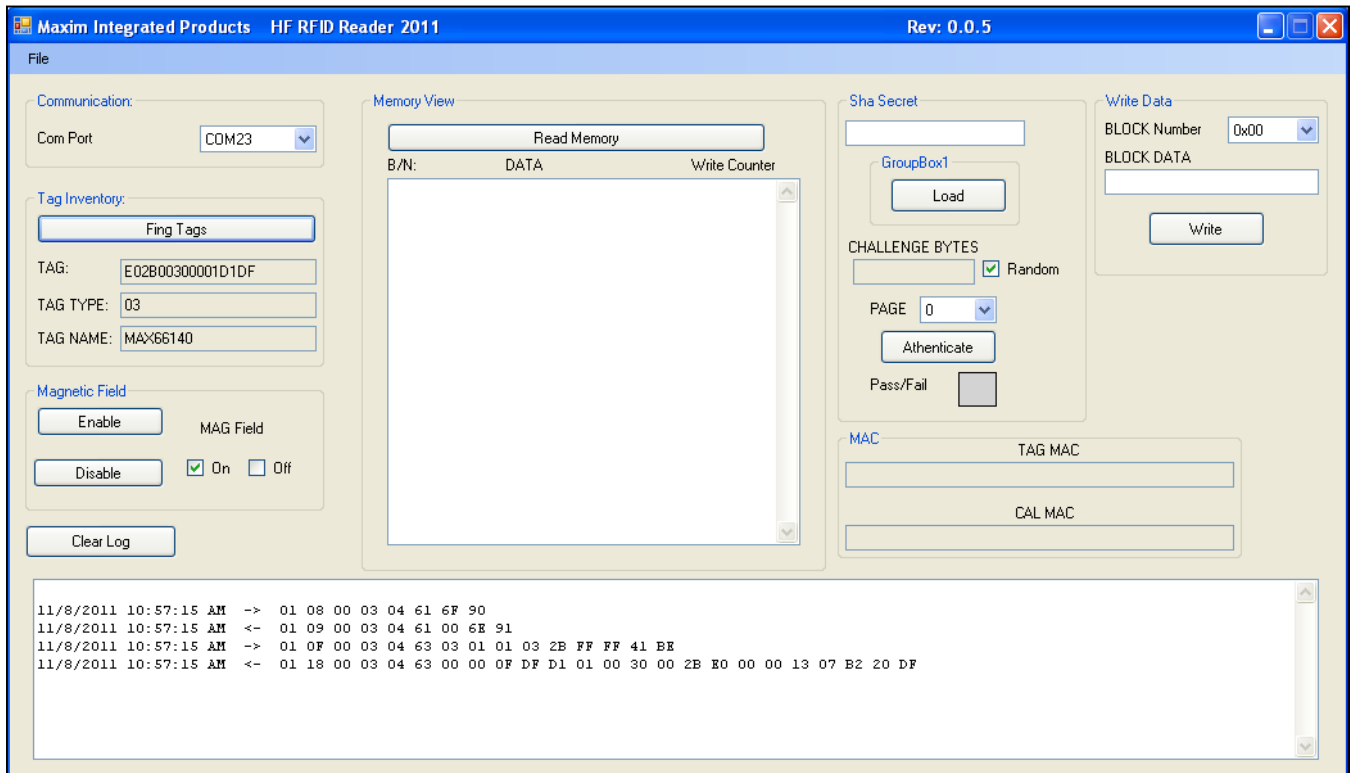

Figure 3. Find Tags
Maxim Integrated

MAX66903 Evaluation Kit

Evaluates: MAX66100/MAX66120/MAX66140

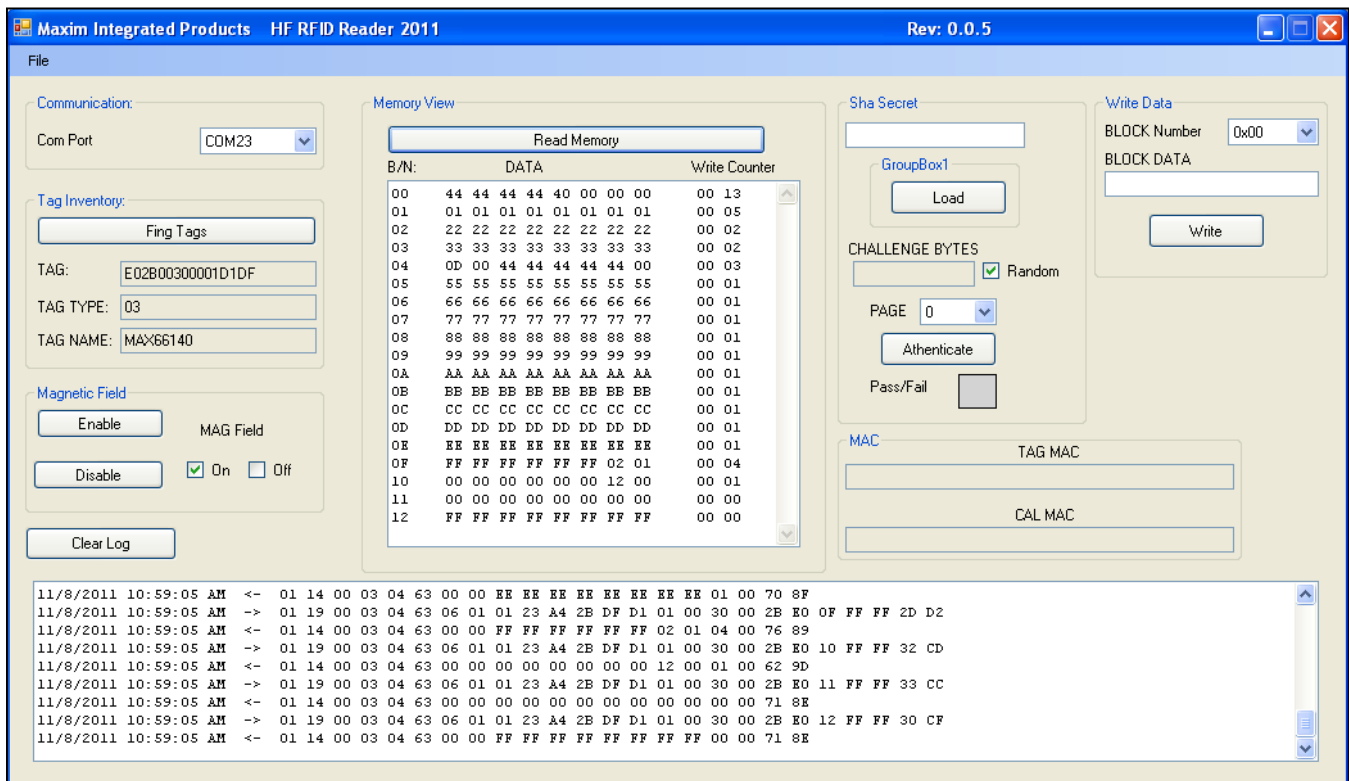

Figure 4. Select Read Memory

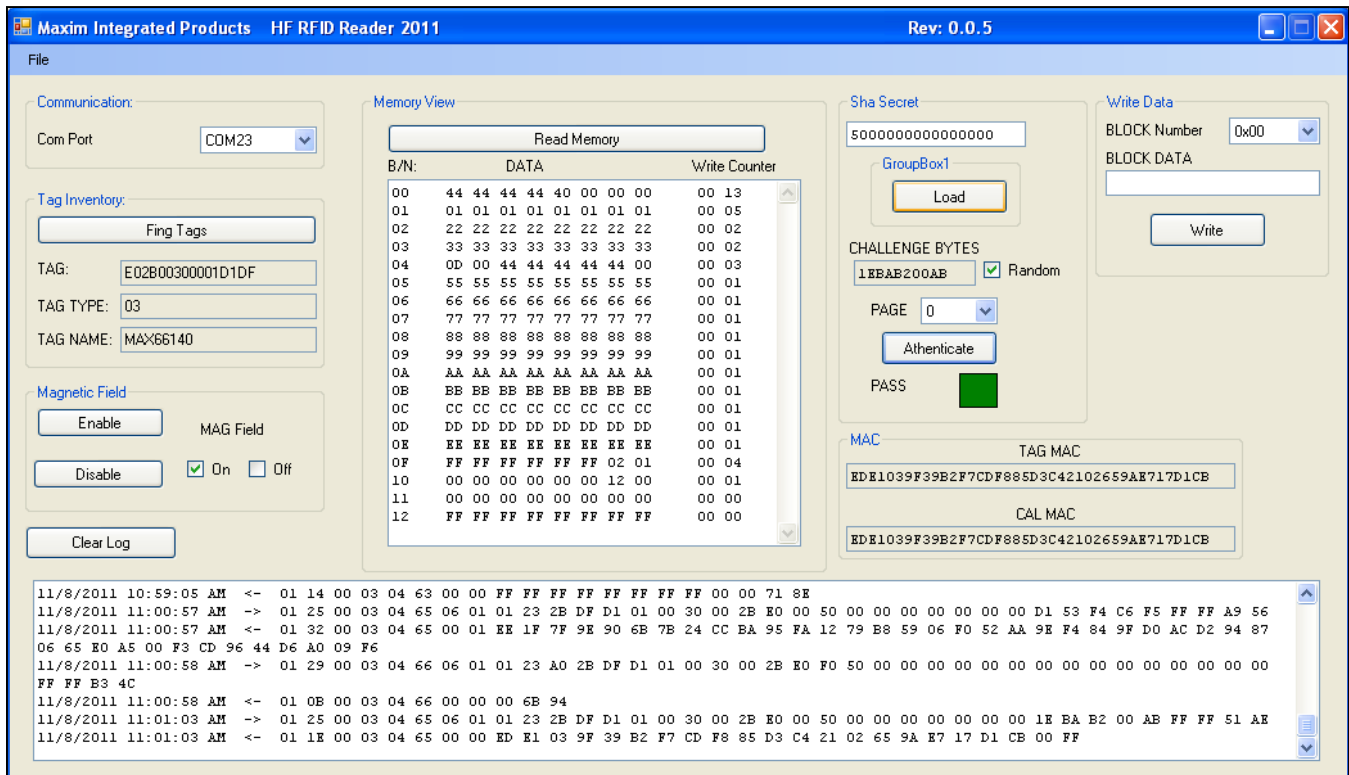

Figure 5. Load Secret and Authenticate Tag

MAX66903 Evaluation Kit

Evaluates: MAX66100/MAX66120/MAX66140

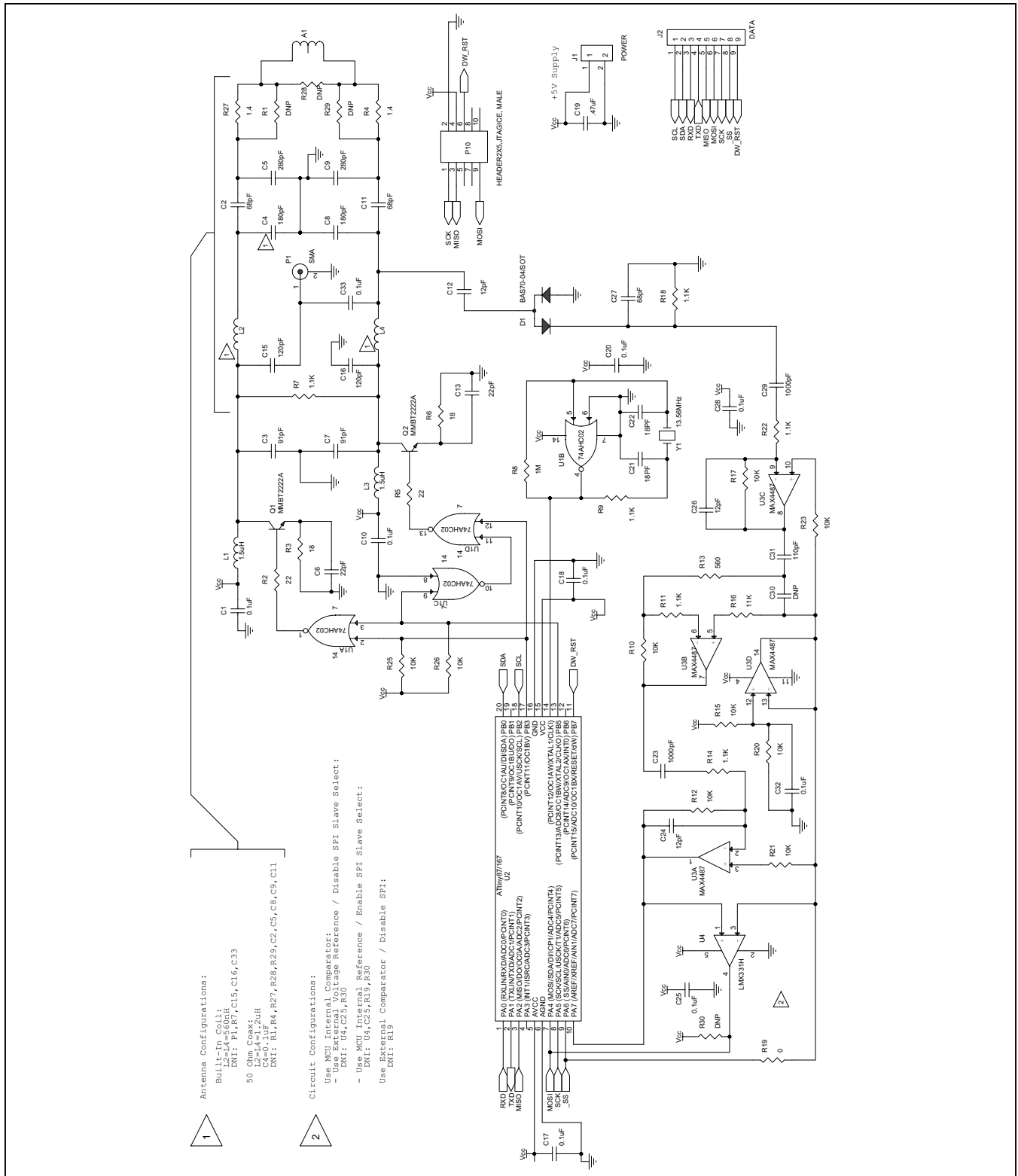

Figure 6. MAX66903 EV Kit Schematic (Sheet 1 of 2)

MAX66903 Evaluation Kit

Evaluates: MAX66100/MAX66120/MAX66140

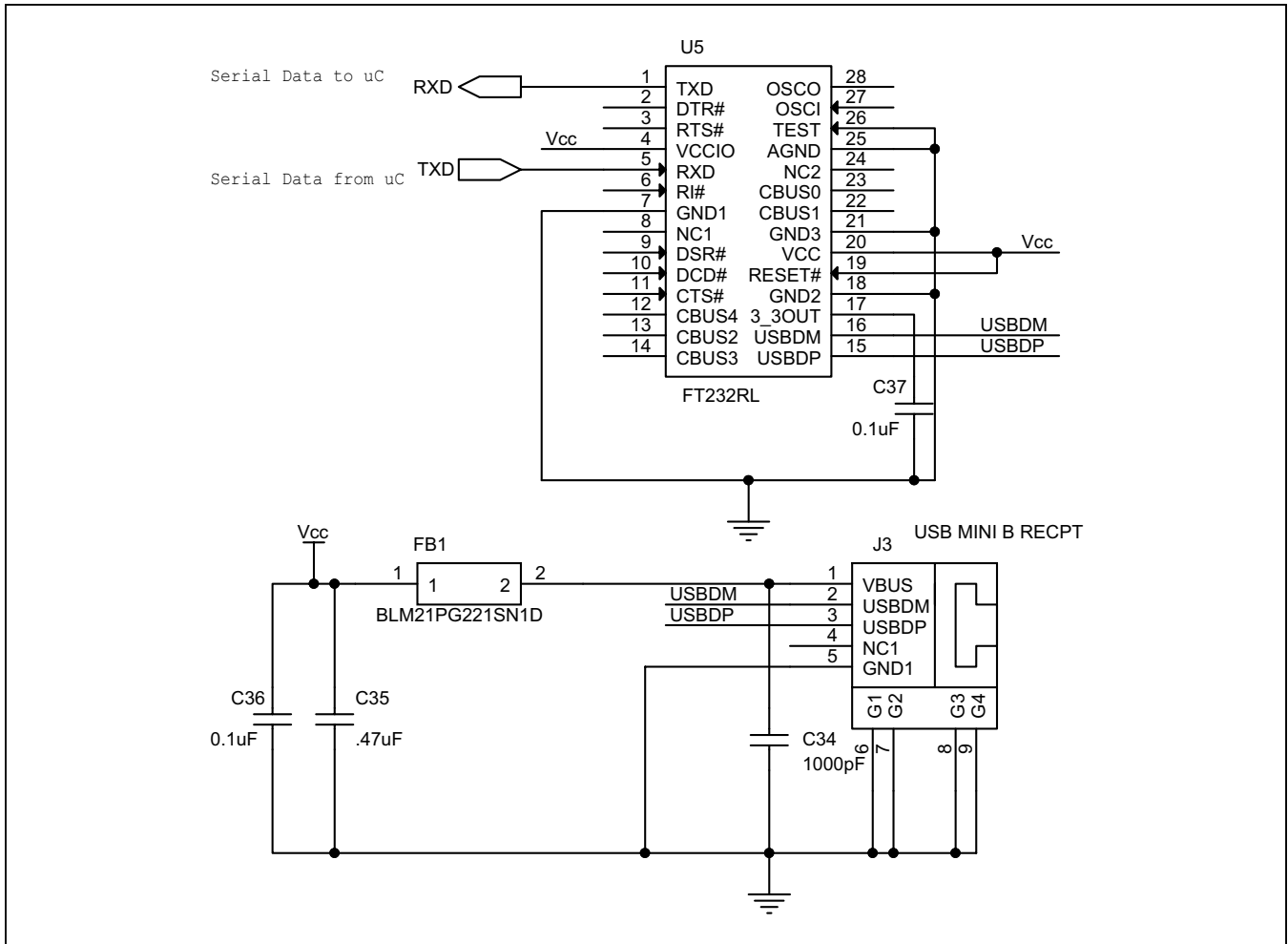

Figure 7. MAX66903 EV Kit Schematic (Sheet 2 of 2)

MAX66903 Evaluation Kit

Evaluates: MAX66100/MAX66120/MAX66140

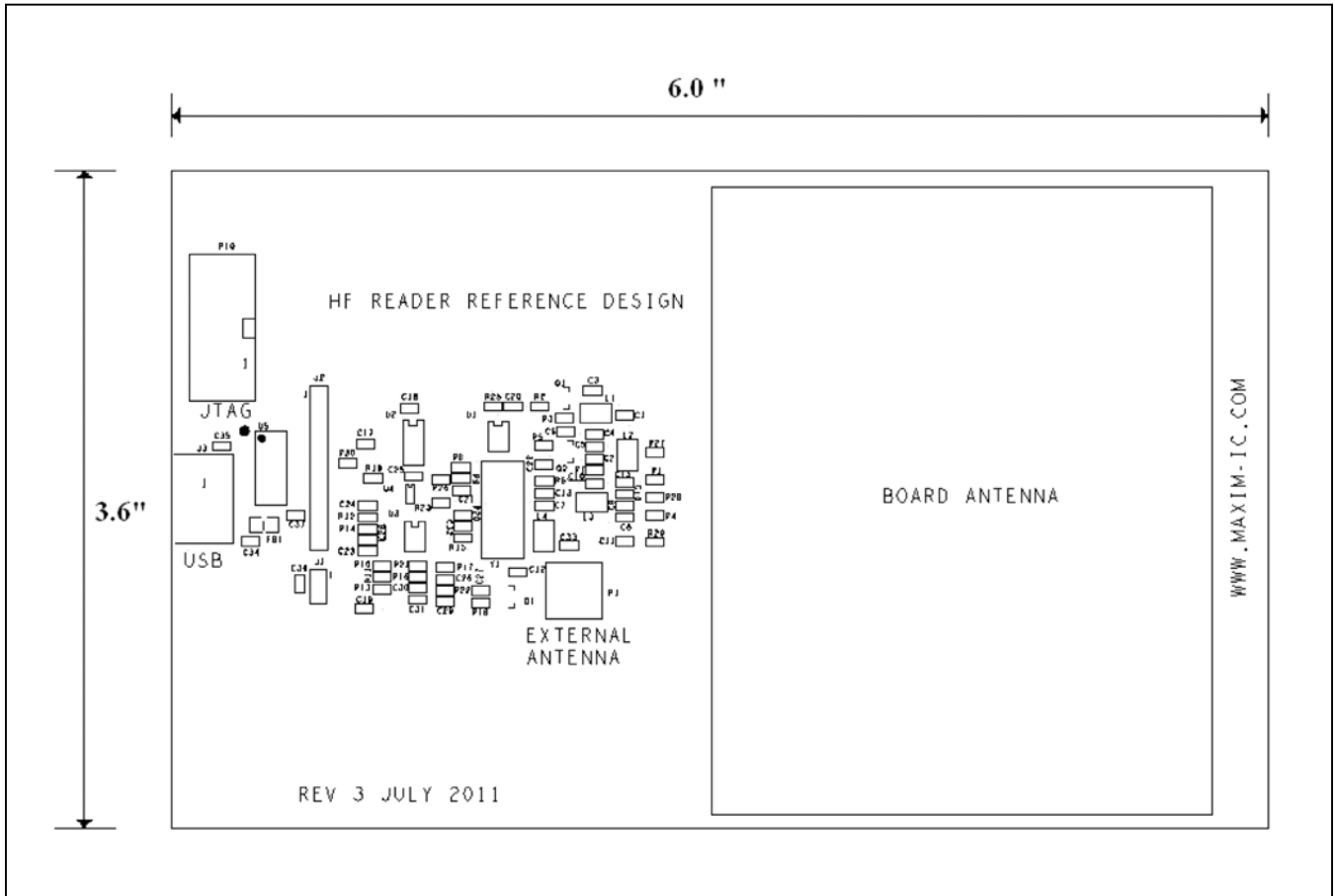

Figure 8. MAX66903 EV Kit Component Placement Guide—Component Side

MAX66903 Evaluation Kit

Evaluates: MAX66100/MAX66120/MAX66140

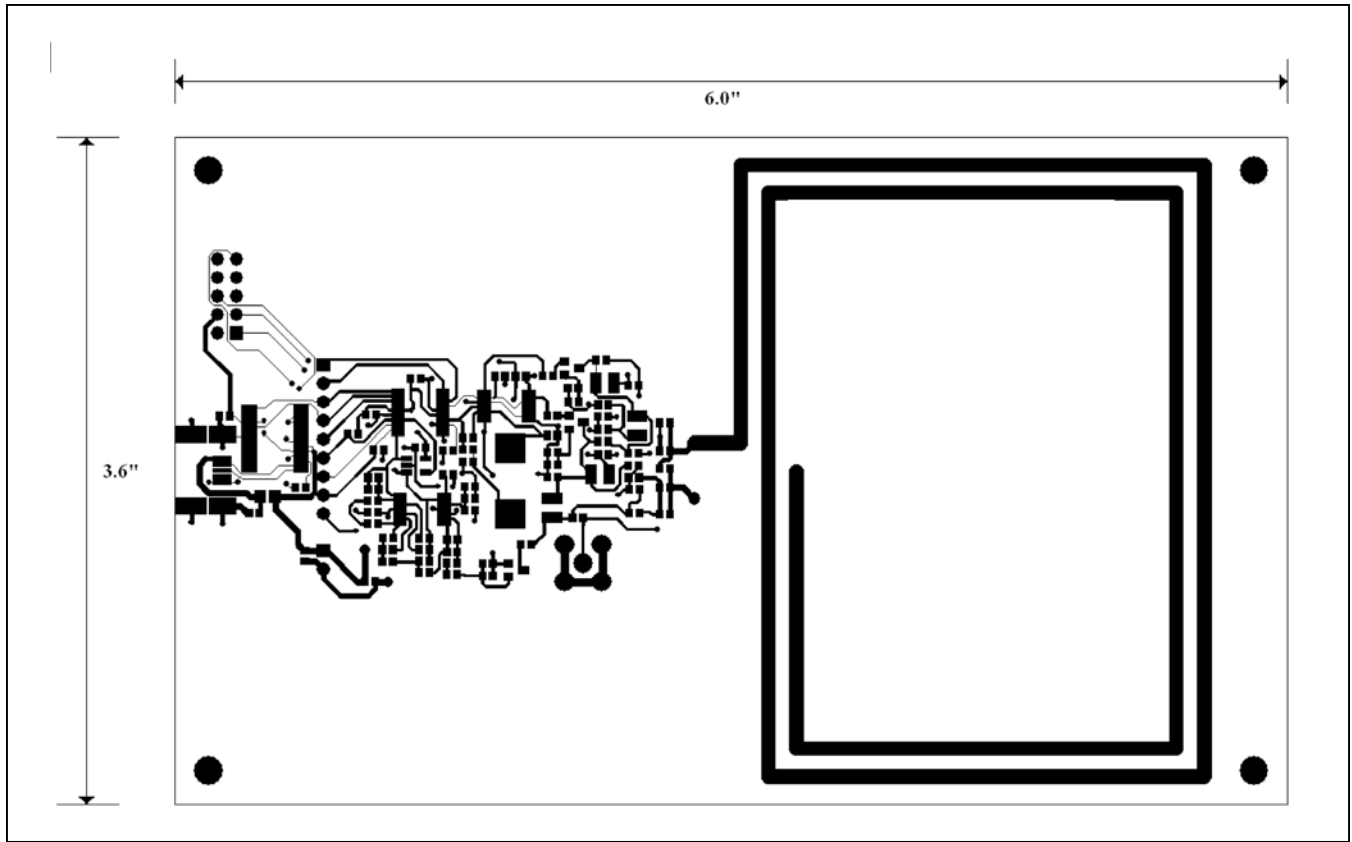

Figure 9. MAX66903 EV Kit PCB Layout—Top Copper

MAX66903 Evaluation Kit

Evaluates: MAX66100/MAX66120/MAX66140

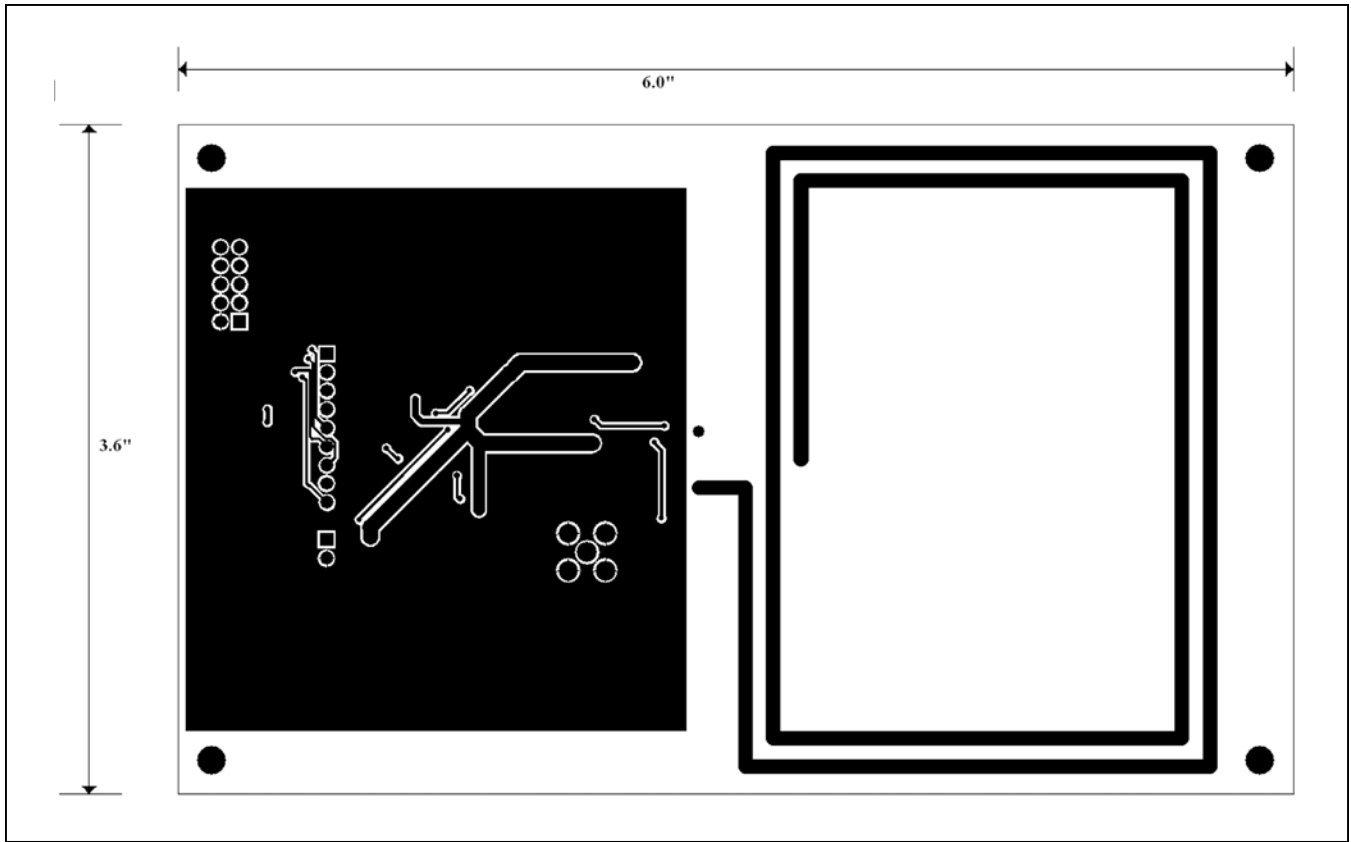

Figure 10. MAX66903 EV Kit PCB Layout—Bottom Copper

MAX66903 Evaluation Kit

Evaluates: MAX66100/MAX66120/MAX66140

Ordering Information

PART	TYPE
MAX66903-K00	EV Kit

MAX66903 Evaluation Kit

Evaluates: MAX66100/MAX66120/MAX66140

Revision History

REVISION NUMBER	REVISION DATE	DESCRIPTION	PAGES CHANGED
0	8/12	Initial release	—



Maxim Integrated cannot assume responsibility for use of any circuitry other than circuitry entirely embodied in a Maxim Integrated product. No circuit patent licenses are implied. Maxim Integrated reserves the right to change the circuitry and specifications without notice at any time. The parametric values (min and max limits) shown in the Electrical Characteristics table are guaranteed. Other parametric values quoted in this data sheet are provided for guidance.

Maxim Integrated 160 Rio Robles, San Jose, CA 95134 USA 1-408-601-1000

13