



MAX8568A Evaluation Kit

General Description

The MAX8568A evaluation kit (EV kit) is a fully assembled and tested circuit board that evaluates the MAX8568A and MAX8568B complete backup-management ICs for lithium and NiMH batteries. The MAX8568A EV kit can charge both NiMH and rechargeable lithium battery types; the EV kit default setting is for NiMH charging. Two on-board p-channel MOSFETs allow the evaluation of backup switchover from the primary source. Low-voltage backup cells can be stepped up by the on-chip synchronous-rectified step-up DC-DC converter, which has a default setting of 3.3V on the EV kit and is capable of 50mA output current. A secondary output provided by an on-chip LDO has a 2.5V output voltage for the MAX8568A and is capable of providing 10mA output current. When the main battery is connected, these two voltages are typically provided by a MAX1586/MAX1587 multi-output complete system power supply. The MAX8568A EV kit can also evaluate the MAX8568B. To evaluate the MAX8568B, order a free sample along with this EV kit.

Features

- ◆ Charges Both NiMH and Rechargeable Lithium Backup Batteries
- ◆ Internal Switch Step-Up DC-DC Converter for 1-Cell NiMH Battery Input
- ◆ Two Backup Output Voltages
 - 3.3V, 50mA Step-Up DC-DC Converter
 - 2.5V, 10mA LDO
- ◆ Programmable Charge Current
- ◆ Programmable Charge Voltage Limit
- ◆ On Board p-Channel MOSFETs for Backup Switchover
- ◆ Fully Assembled and Tested

Ordering Information

PART	TEMP RANGE	IC PACKAGE
MAX8568AEVKIT	0°C to +70°C	16 Thin QFN 3mm x 3mm

Component List

DESIGNATION	QTY	DESCRIPTION
C1, C4	2	4.7 μ F \pm 10%, 6.3V X5R ceramic capacitors (0603) Murata GRM188R60J475K
C2, C3	2	10 μ F \pm 10%, 6.3V X5R ceramic capacitors (0805) Murata GRM219R60J106K
C5	1	0.22 μ F \pm 10%, 6.3V X5R ceramic capacitor (0402) Murata GRM155R60J224K
JU1	1	3-pin header
L1	1	10 μ H inductor Murata LQH32CN100K53
Q1, Q2	2	-12V, 50m Ω (max), SOT23 Fairchild Semiconductor FDN306P

DESIGNATION	QTY	DESCRIPTION
R1	0	Open, resistor (0402)
R2, R7	2	0 Ω resistors (0402)
R3, R4	2	100k Ω \pm 1% resistors (0402)
R5	1	169k Ω \pm 1% resistor (0402)
R6	1	49.9k Ω \pm 1% resistor (0402)
R8	1	1.2M Ω \pm 5% resistor (0402)
R9	1	357k Ω \pm 1% resistor (0402)
R10	1	1M Ω \pm 1% resistor (0402)
U1	1	MAX8568A
None	1	Shunts
None	1	MAX8568A PC board

Component Suppliers

SUPPLIER	COMPONENT	PHONE	WEBSITE
Fairchild Semiconductor	MOSFET	972-910-8000	www.fairchildsemi.com
Kamaya	Resistors	260-489-1533	www.kamaya.com
Murata	Capacitor, Inductor	814-237-1431	www.murata.com

Note: Indicate that you are using the MAX8568A when contacting these component suppliers.



For pricing, delivery, and ordering information, please contact Maxim/Dallas Direct! at 1-888-629-4642, or visit Maxim's website at www.maxim-ic.com.

MAX8568A Evaluation Kit

Quick Start

Recommended Equipment

- MAX1586A EV kit
- One variable-DC power supply (further referred to as PS1) capable of supplying up to 5.5V at 1A
- One variable-DC power supply (further referred to as PS2) capable of supplying up to 5V at 150mA
- Two digital multimeters (DMM)
- One 75 Ω , 1/10W resistor
- 20mA load
- 5mA load
- Ammeter

Procedure (Charging)

Follow the steps below to verify board operation:

- 1) Preset the variable-DC power supply, PS1, to 4.2V. Turn off the power supply. **Do not turn on the power supply until all connections are complete:**
- 2) Preset the variable-DC power supply, PS2, to 1.3V. Turn off the power supply. **Do not turn on the power supply until all connections are complete:**
- 3) Connect the 75 Ω resistor from the positive lead of PS2 to the negative lead of PS2. This allows PS2 to sink current to simulate a rechargeable backup battery.
- 4) Connect the positive lead of PS1 to the VIN pad on the MAX1586A EV kit and connect the negative lead of PS1 to the GND pad on the MAX1586A EV kit.
- 5) Connect the VIN pad of the MAX1586A EV kit, as shown in Figure 1, to the MAIN pad of the MAX8568A EV kit.
- 6) Connect the VCC_I/O pad of the MAX1586A EV kit to the I/O IN pad of the MAX8568A EV kit.
- 7) Connect the VCC_MEM pad of the MAX1586A EV kit to the MEM IN pad of the MAX8568A EV kit.
- 8) Connect the GND pad of the MAX1586A EV kit to the GND pad of the MAX8568A EV kit.
- 9) Connect the positive lead of the ammeter (50mA setting/capability) to the BK pad on the MAX8568A EV kit. Connect the negative lead of the ammeter to the positive lead of PS2. Connect the negative lead of PS2 to the GND pad on the MAX8568A EV kit.
- 10) Connect the positive lead of a DMM to the BK pad on the MAX8568A EV kit and connect the negative lead of that DMM to the GND pad on the MAX8568A EV kit.
- 11) Verify that the shunt on JU1 is in the NI position.

- 12) Turn on PS2, and then turn on PS1.
- 13) Verify that the voltage at BK is approximately 1.3V. Verify that charging current from BK is approximately 10mA.
- 14) Increase the voltage at BK to 1.5V. Verify that charging current from BK is approximately 1mA.
- 15) Decrease the voltage at BK to 1.15V. Verify that charging current from BK is approximately 10mA.
- 16) Increase the voltage at BK to 1.85V. Verify that charging current from BK is approximately 0mA.

Procedure (Backup Switchover)

Follow the steps below to verify board operation:

- 1) Repeat steps 1 through 8 above (from the Procedure (Charging) section).
- 2) Connect the positive lead of PS2 to the BK pad and the negative lead of PS2 to the GND pad on the MAX8568A EV kit.
- 3) Connect the positive lead of one DMM to the I/O OUT pad on the MAX8568A EV kit and connect the negative lead of that DMM to the GND pad on the MAX8568A EV kit.
- 4) Connect the positive lead of the second DMM to the MEM OUT pad on the MAX8568A EV kit and connect the negative lead of that DMM to the GND pad on the MAX8568A EV kit.
- 5) Connect the 20mA load from I/O OUT to GND.
- 6) Connect the 5mA load from MEM OUT to GND.
- 7) Verify that the shunt on JU1 is in the NI position.

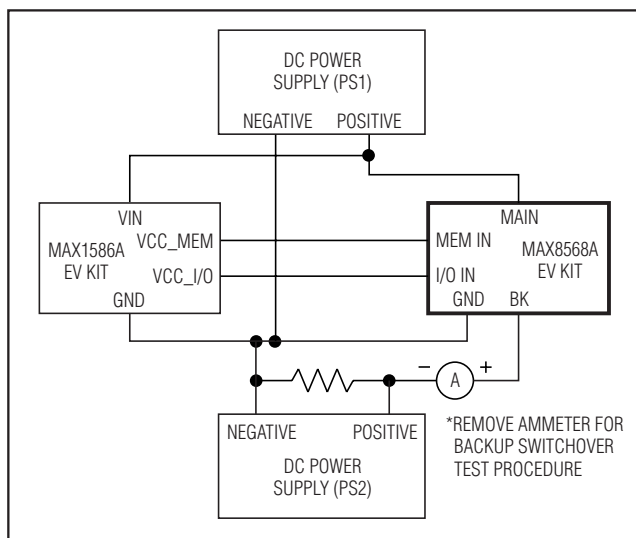

Figure 1. Quick-Start Wiring Diagram

MAX8568A Evaluation Kit

- 8) Turn on PS2, and then turn on PS1.
- 9) Verify that the voltage at I/O OUT is approximately 3.3V. Verify that the voltage at MEM OUT is approximately 2.5V.
- 10) Turn off PS1.
- 11) Verify that the voltage at I/O OUT is approximately 3.3V. Verify that the voltage at MEM OUT is approximately 2.5V.

Detailed Description

Evaluating the MAX8568A EV Kit Without the MAX1586A

To evaluate the MAX8568A without the MAX1586A, four power supplies are required. These supply MAIN (4.2V), BK (1.3V), I/O IN (3.3V), and MEM IN (2.5V). Note that the backup-battery boost converter will not operate unless I/O IN has been activated at least one time. The typical power removal sequence for testing is 1) main battery goes low, then 2) MEM IN and I/O IN go low.

Setting the Charge Current

Charge current is set by a resistor connected from CHGI to GND, R5 in Figure 2. The acceptable resistor range is from 50k Ω to 1800k Ω . Charge current is calculated by the following:

$$R_{\text{CHGI}}(\text{k}\Omega) = \left[\frac{41.2 \times (V_{\text{IN}} - V_{\text{BK}}) + 679.4}{I_{\text{CHG}}(\text{mA})} \right]^{1.1641}$$

where V_{BK} is the nominal voltage of the charged backup battery. This is the fast-charge current for both NiMH and lithium batteries. For NiMH batteries, the trickle-charge is 10% of the fast-charge current.

Setting the Fast-Charge-to-Trickle-Charge Transition Points

One 3-resistor-divider can be used to set the BK voltage where fast-charge begins ($V_{\text{BK(NILO)}}$) and the BK voltage where trickle-charge begins ($V_{\text{BK(NIHI)}}$) independently. $V_{\text{BK(NILO)}}$, $V_{\text{BK(NIHI)}}$, and the BK voltage where all charging stops ($V_{\text{BK(NIMAX)}}$) are defined as follows:

BK voltage where fast-charge begins:

$$V_{\text{BK(NILO)}} = V_{\text{STRTV}}$$

BK voltage where trickle-charge begins:

$$V_{\text{BK(NIHI)}} = 1.163 \times V_{\text{TERMV}}$$

BK voltage where all charging stops:

$$V_{\text{BK(NIMAX)}} = 1.493 \times V_{\text{TERMV}}$$

Figure 2 shows the connection of R6, R7, and R8. Select R8 in the 100k Ω to 2M Ω range. The equations for the two upper divider-resistors are:

$$R7 = R8 \times \left(\frac{V_{\text{BK(NIHI)}}}{1.163 \times V_{\text{BK(NILO)}}} - 1 \right)$$

$$R6 = (R7 + R8) \times \left(\frac{1.163 \times V_{\text{REF}}}{V_{\text{BK(NIHI)}}} - 1 \right)$$

where V_{REF} is 1.25V. The MAX8568A/MAX8568B data sheet discusses using a NiMH backup battery in more detail.

Evaluating Rechargeable Lithium Backup Batteries

The MAX8568A EV kit can charge a lithium-type backup battery from the main battery connected at MAIN. Connect a shunt on jumper JU1 to the pins labeled LI for lithium backup-battery charging.

The lithium charger acts like a current-limited voltage source.

The MAX8568A/MAX8568B data sheet discusses using a lithium backup battery in more detail.

Evaluating the MAX8568B

For evaluating the MAX8568B, carefully remove the MAX8568A and install the MAX8568B. All other components can remain the same.

MAX8568A Evaluation Kit

Evaluates: MAX8568A/MAX8568B

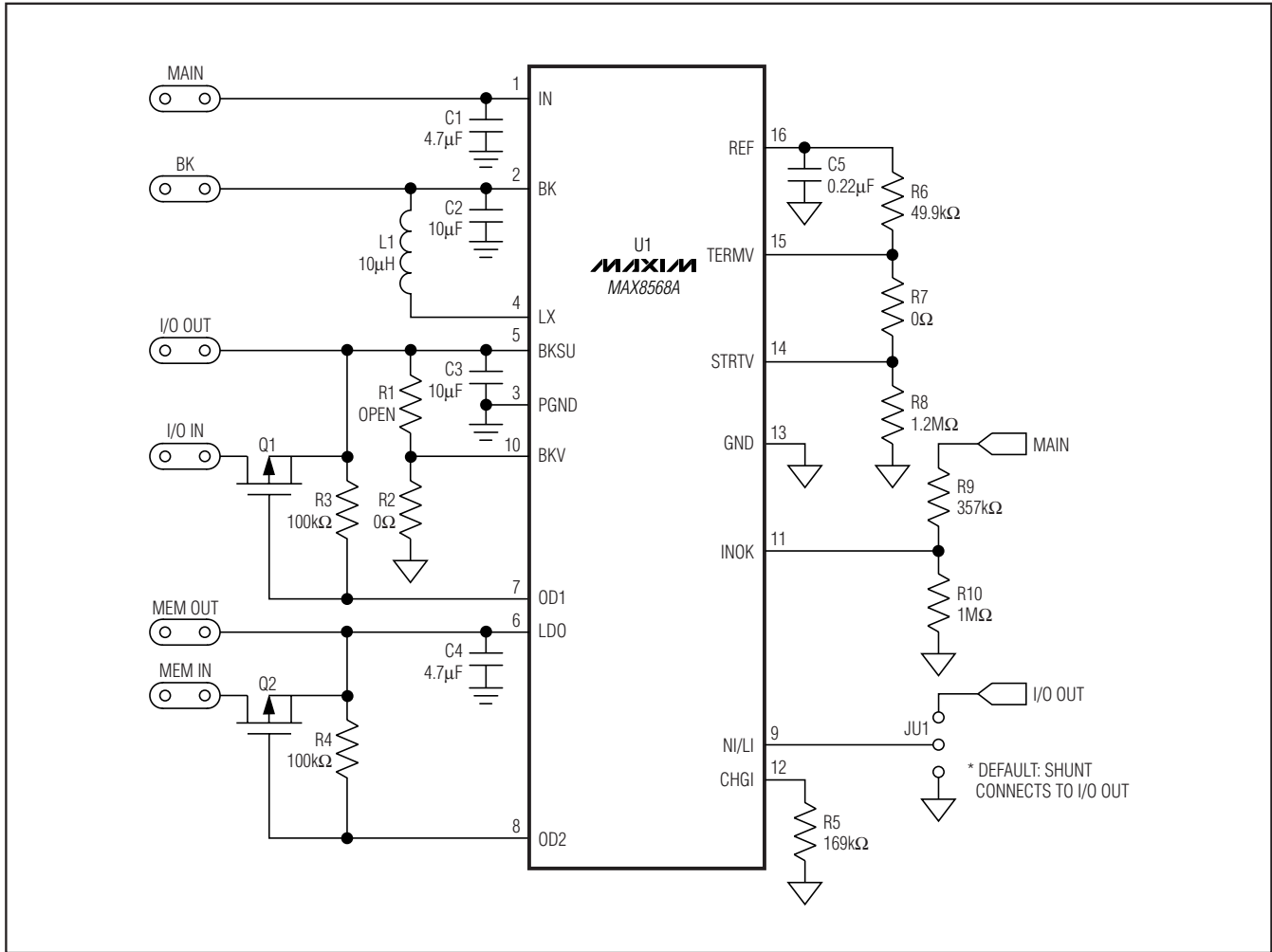

Figure 2. MAX8568A EV Kit Schematic

MAX8568A Evaluation Kit

Evaluates: MAX8568A/MAX8568B

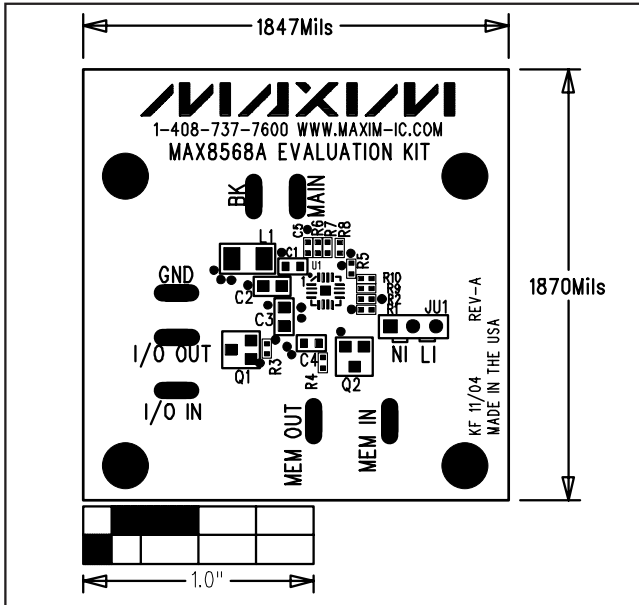

Figure 3. MAX8568A EV Kit Component Placement Guide—Component Side

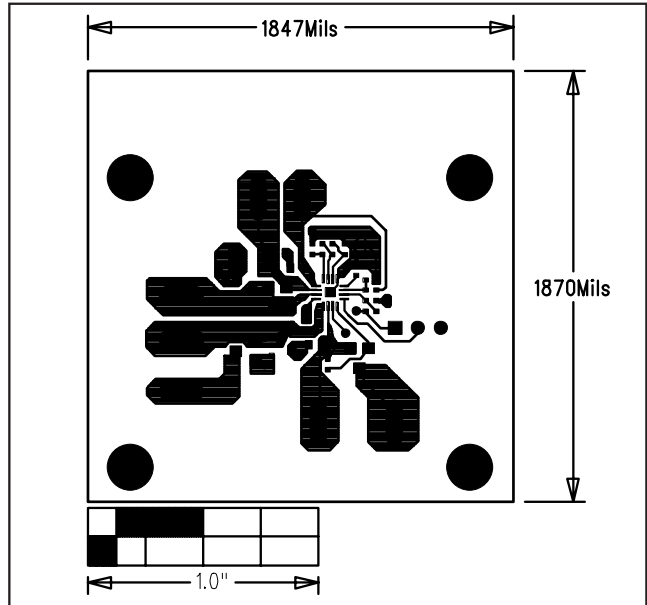

Figure 4. MAX8568A EV Kit PC Board Layout—Component Side

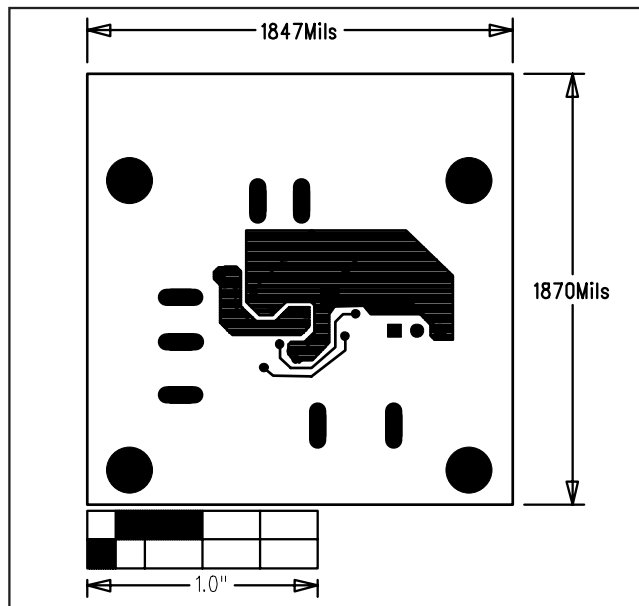

Figure 5. MAX8568A EV Kit PC Board Layout—Solder Side

Maxim cannot assume responsibility for use of any circuitry other than circuitry entirely embodied in a Maxim product. No circuit patent licenses are implied. Maxim reserves the right to change the circuitry and specifications without notice at any time.

Maxim Integrated Products, 120 San Gabriel Drive, Sunnyvale, CA 94086 408-737-7600 _____ 5