

MAX86171 Evaluation System

Evaluates: MAX86171/
MAX86170A/MAX86170B

General Description

The MAX86171 evaluation system (EV sys) allows for the quick evaluation of the MAX86171 optical AFE for applications at various sites on the body, particularly the wrist. MAX86171 supports both I²C and SPI compatible interfaces. MAX86171 has two optical readout channels that operate simultaneously. The EV sys allows flexible configurations to optimize measurement signal quality at minimal power consumption. The EV sys helps the user quickly learn about how to configure and use the MAX86171.

The EV sys consists of two boards. MAXSensor BLE is the main data acquisition board while MAX86171_OSB# is the sensor daughter board for MAX86171. The EV sys can be powered using the USB-C supply or LiPo Battery. The EV sys comes with a MAX86171ENI+ in a 28-bump WLP.

Features

- Quick Evaluation of the MAX86171
- Supports Optimization of Configurations
- Facilitates Understanding MAX86171 Architecture and Solution Strategy
- Real-time Monitoring
- Data Logging Capabilities
- On-Board Accelerometer
- Bluetooth LE

Ordering Information appears at end of data sheet.

Quick Start

Required Equipment

- MAX86171 EV sys
- Data Acquisition EV sys Micro-PCB (MAXSensorBLE#)
- MAX86171 EV sys sensor PCB (MAX86171_OSB#)
- Flex cable
- USB-C cable
- MAX86171 EV sys GUI software
- MAX86171 parser and user guide (included in MAX86171GUISetupVxxx.ZIP)
- Windows PC
- Required bluetooth LE dongle [CY5677](#) or [CY5670](#) (not shipped with EV sys)
- Optional LiPo battery ([LP-401230](#) suggested, not shipped with EV sys)

Note: If you do not already have one of the listed BLE dongles above, purchasing one is recommended.

Procedure

- 1) The EV sys is fully assembled and tested. Follow the steps below to verify board operation:
Visit www.maximintegrated.com/evkit-software to download the most recent version of the EV sys software, MAX86171GUISetupVxxx_Web.ZIP. Save the EV sys software to a temporary folder and decompress the ZIP file.
- 2) Plugged in the BLE dongle to one of the USB port on the PC.
- 3) Open up MAX86171GUISetupVxxx.exe and follow the instructions from the pop-up windows, as shown in [Figure 1](#) to [Figure 7](#).
- 4) The BLE Dongle driver installation will also be completed after the GUI installation, as shown in [Figure 8](#).
- 5) If the MAX86171 EV sys flex cable is not already connecting the Data Acquisition EV sys Micro PCB to the MAX86171 Sensor PCB, then please connect the two PCBs with the cable as shown in [Figure 9](#) and [Figure 10](#).

- 6) Connect USB-C cable or LiPo Battery to the Data Acquisition Board to power up the EV sys. If LiPo battery is used, press the power switch (SW) to turn on/off the device. When powered on, the green LED will toggle.
- 7) After that, start the MAX86171 EV sys GUI program. "Connect Device" will appear, choose your device and press "Connect" as shown in [Figure 11](#).
- 8) The GUI will then be launched as shown in [Figure 12](#) and [Figure 13](#).
- 9) Configure the EV sys on the GUI and Click on the <Start> button on the bottom left side to start the data acquisition.
- 10) When running, the LEDs on the Micro PCB should illuminate and the plots on the GUI should stream with data as shown in [Figure 14](#) and [Figure 15](#).

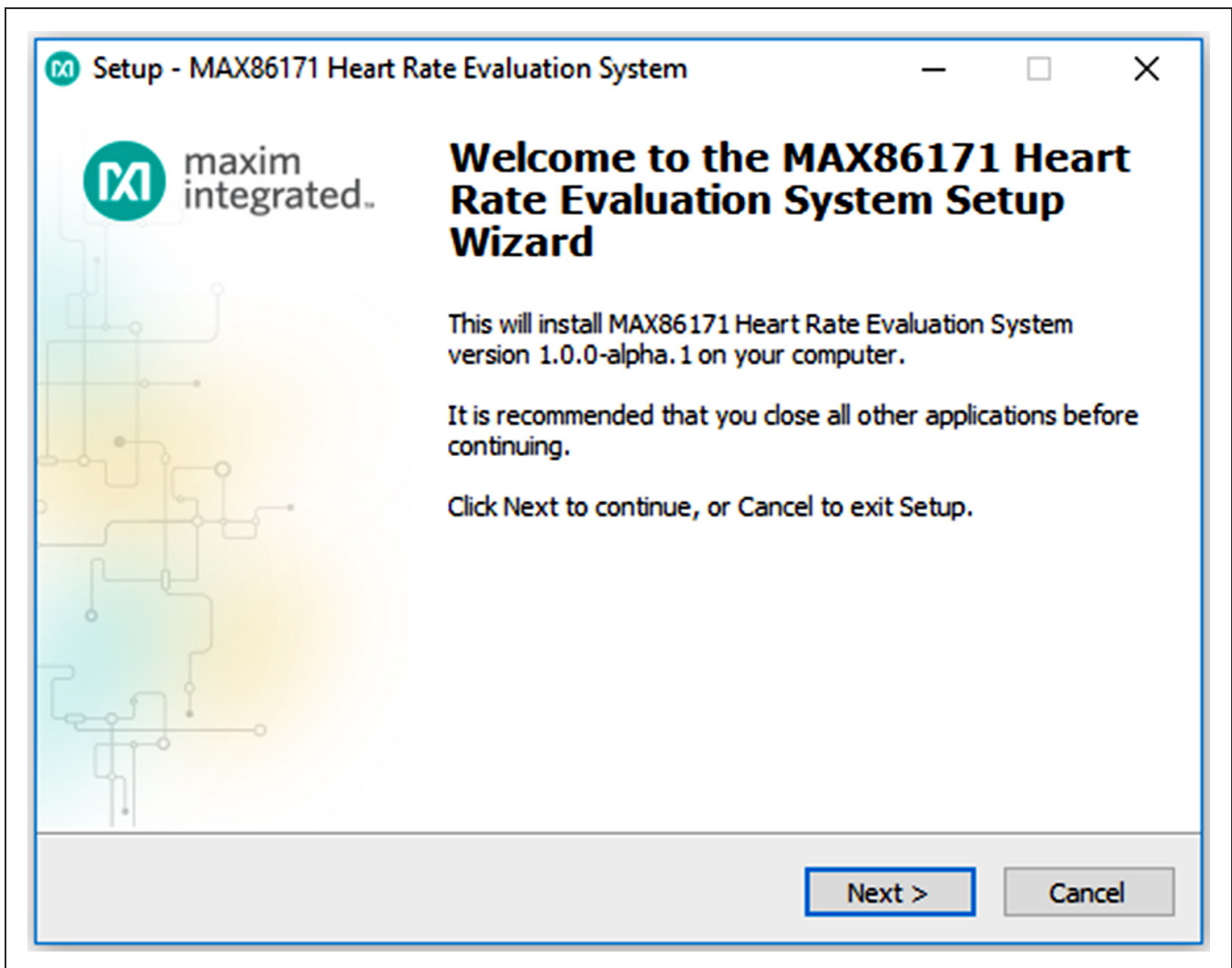

Figure 1. Setup MAX86171 EV Sys GUI Software Step 1

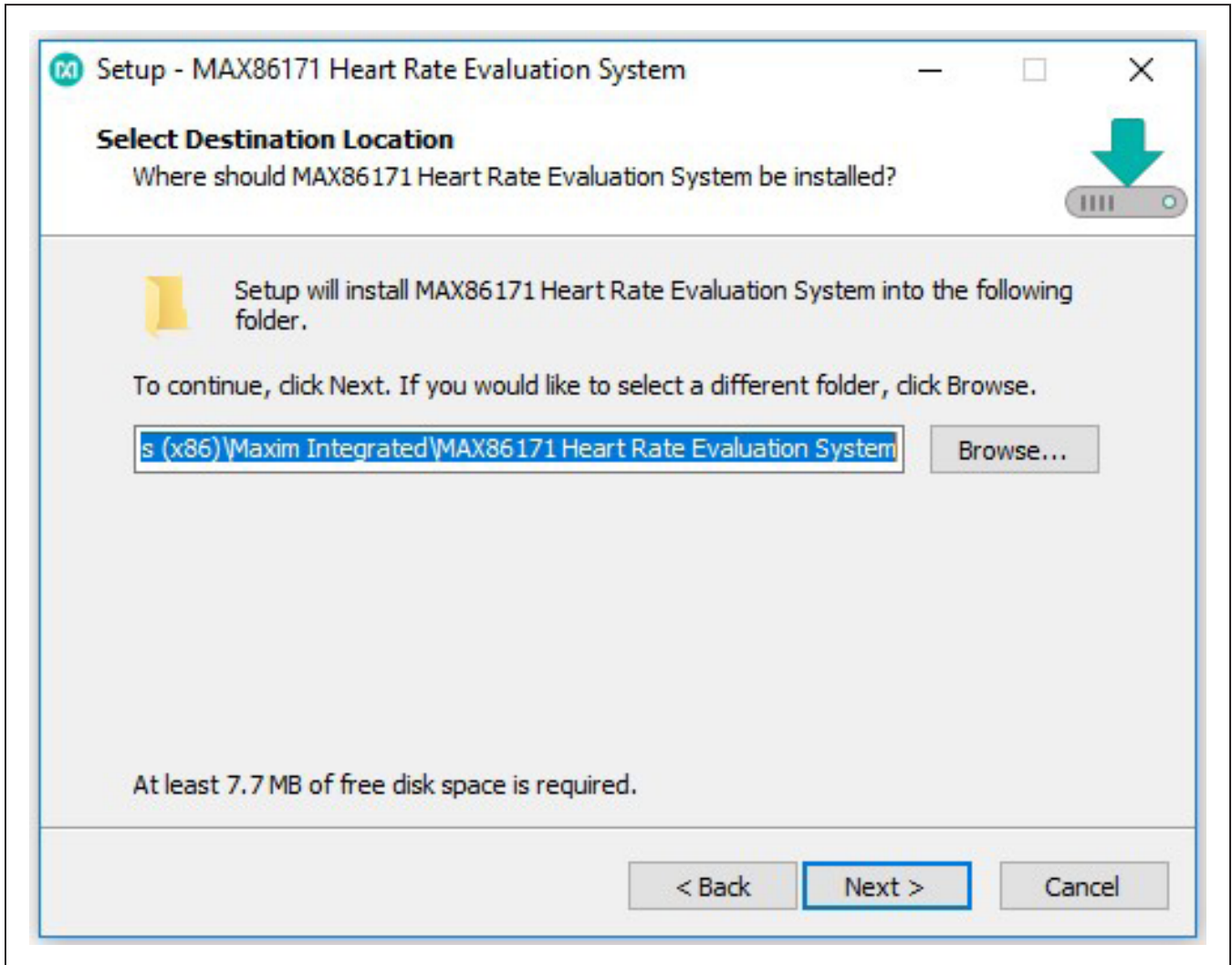

Figure 2. Setup MAX86171 EV Sys GUI Software Step 2

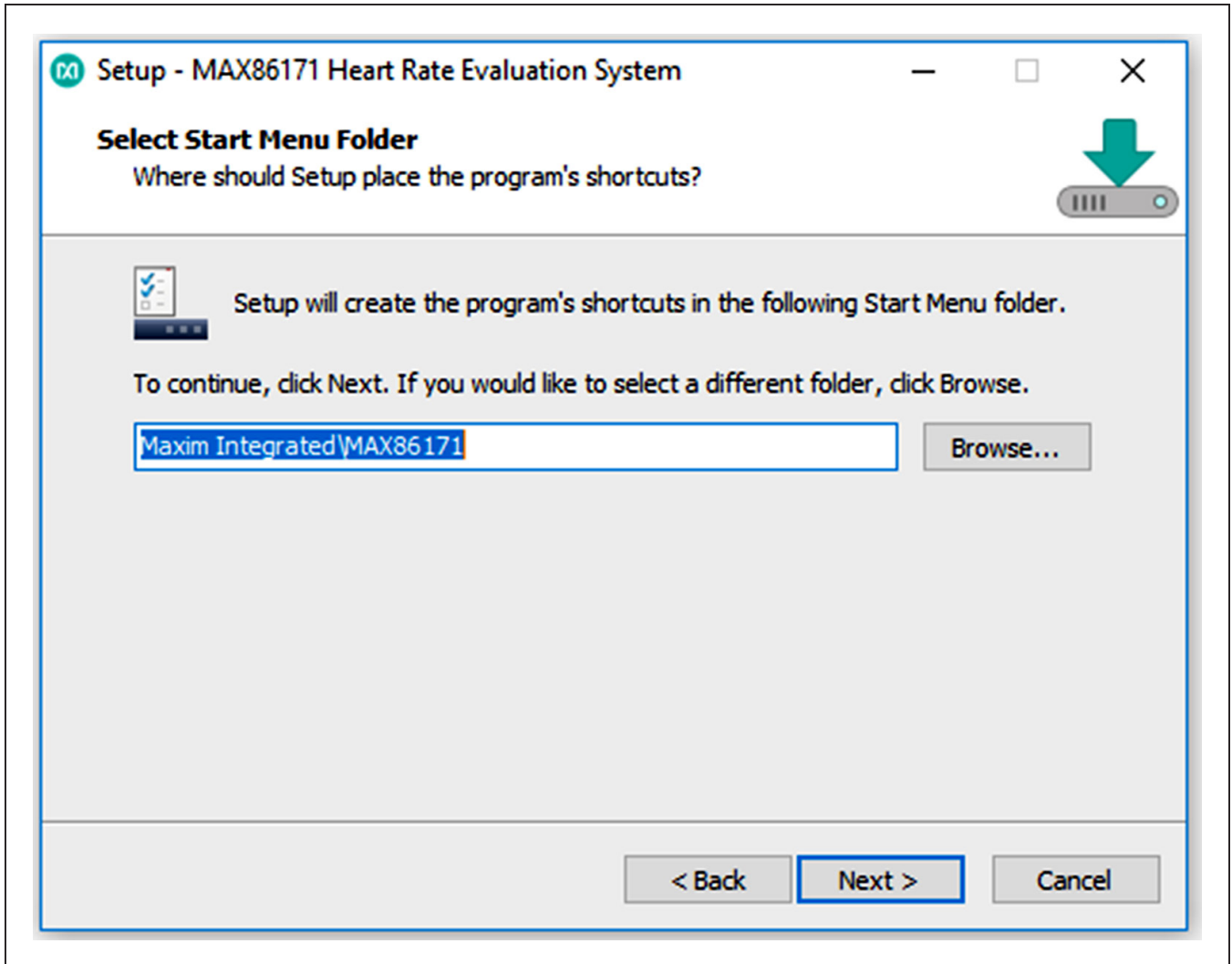

Figure 3. Setup MAX86171 EV Sys GUI Software Step 3

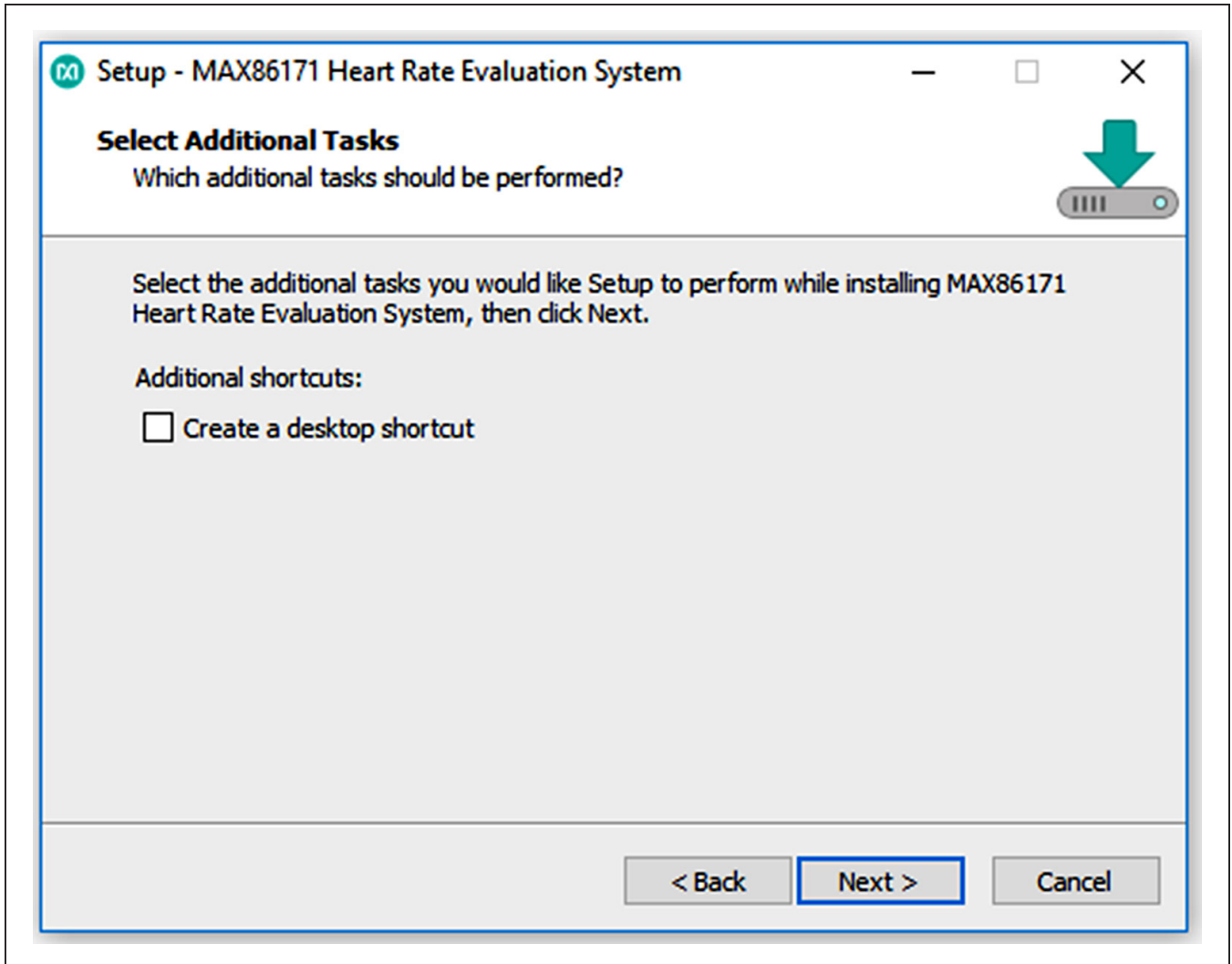

Figure 4. Setup MAX86171 EV Sys GUI Software Step 4

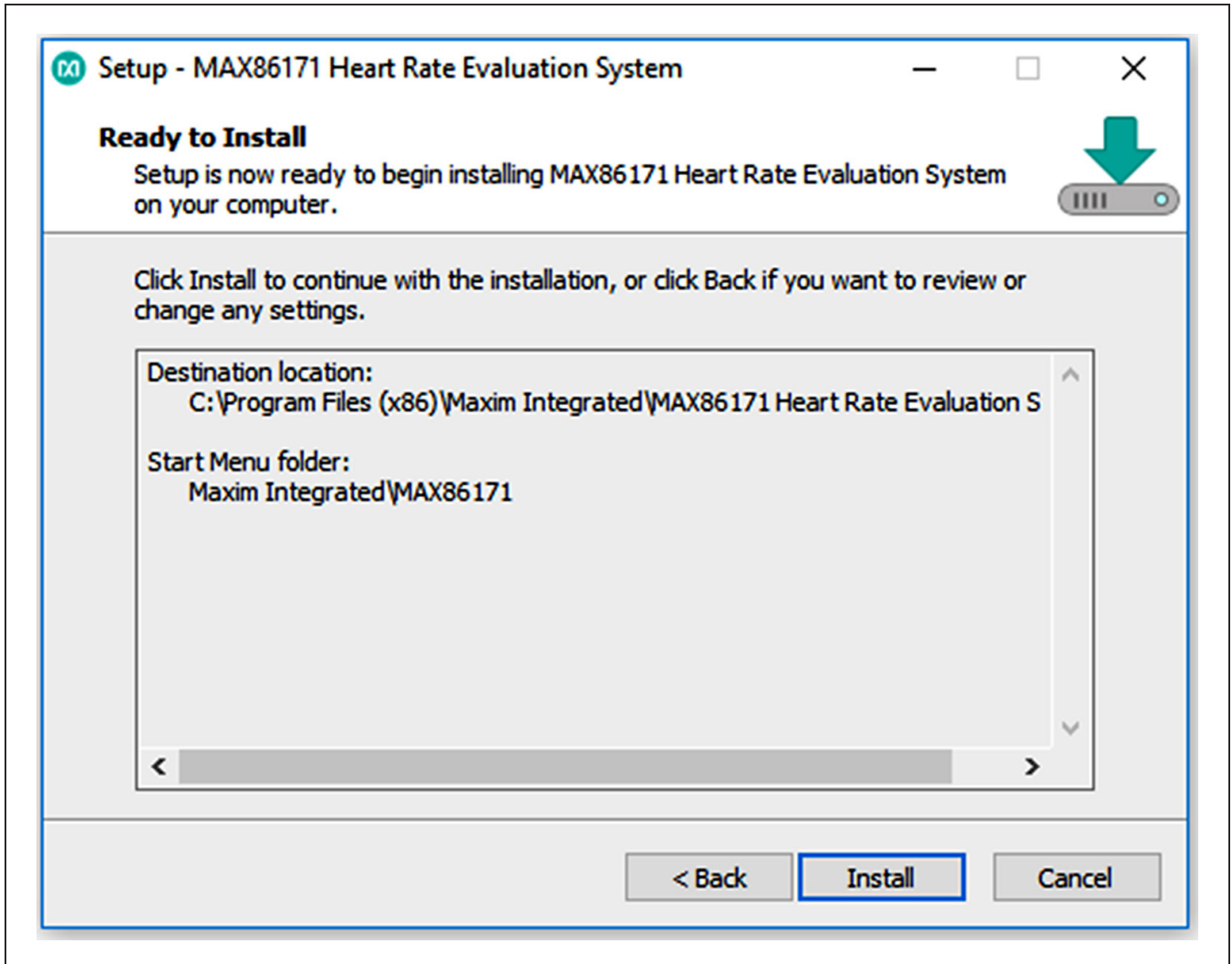

Figure 5. Setup MAX86171 EV Sys GUI Software Step 5

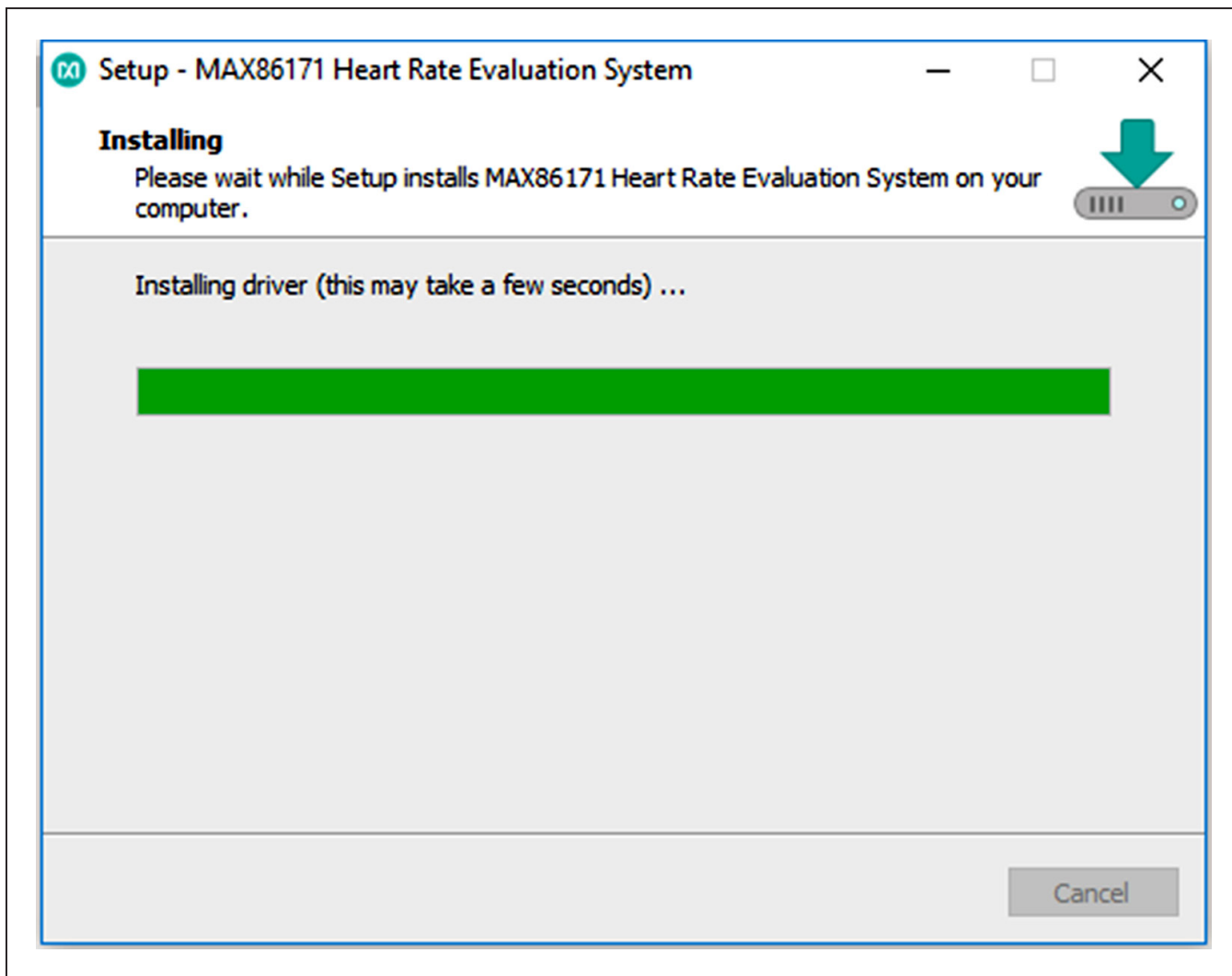

Figure 6. Setup MAX86171 EV Sys GUI Software Step 6

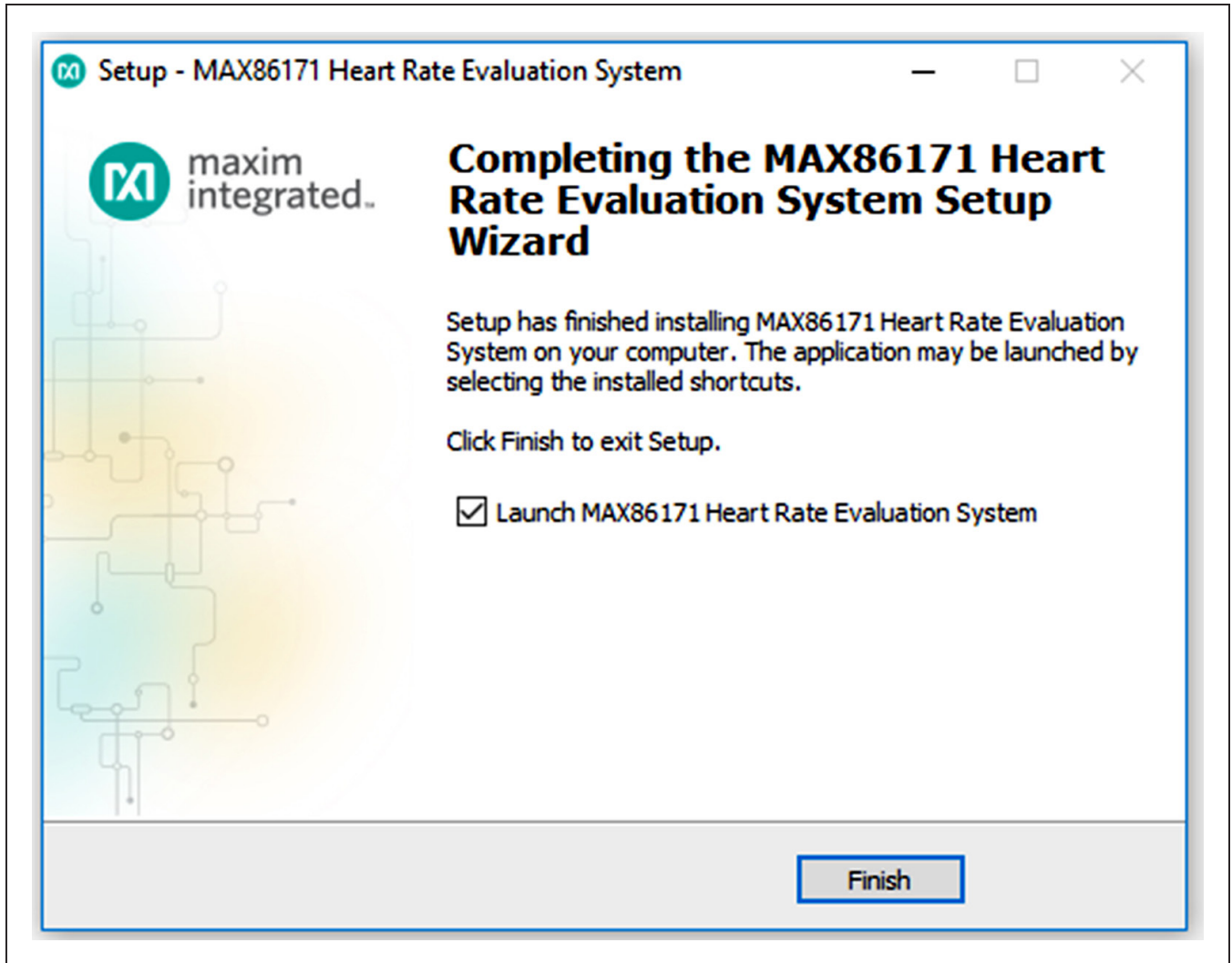

Figure 7. Setup MAX86171 EV Sys GUI Software Step 7

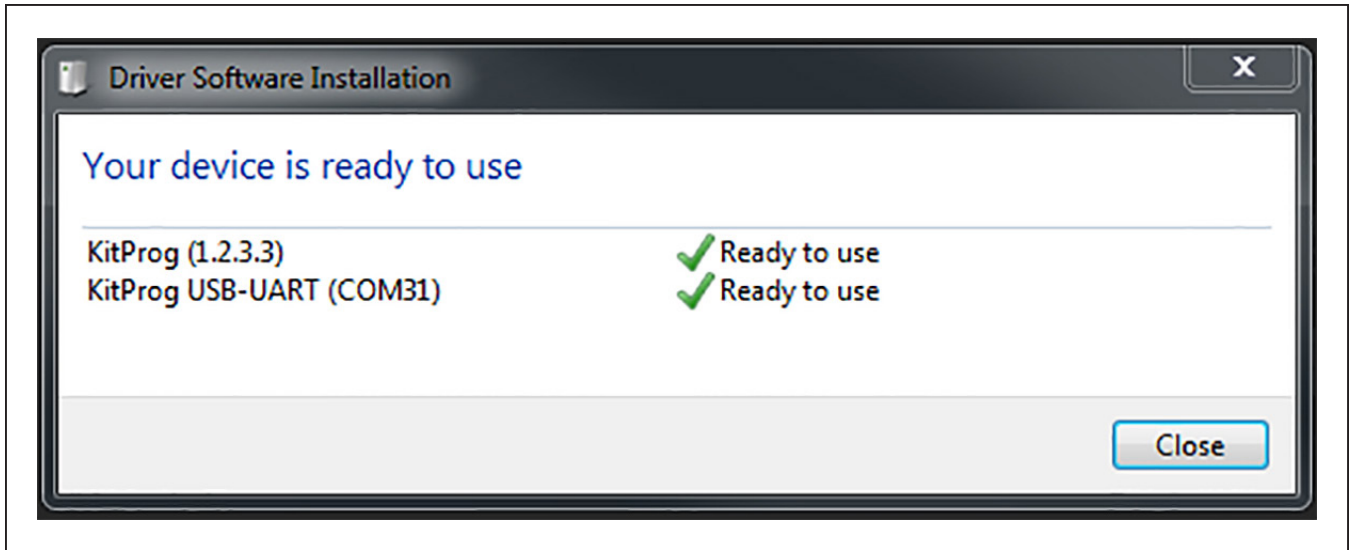

Figure 8. BLE Dongle Driver Installation

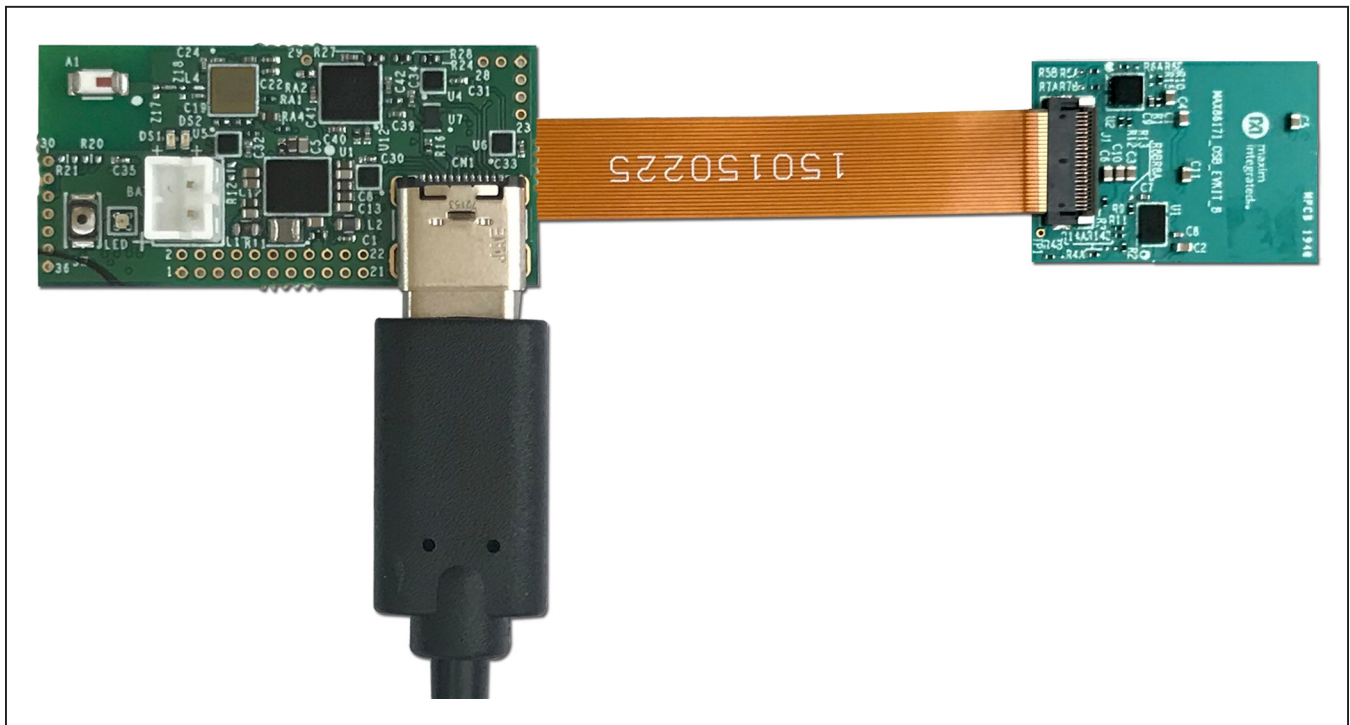

Figure 9. Hardware Setup (MAX86171 EV Sys Micro-PCB)

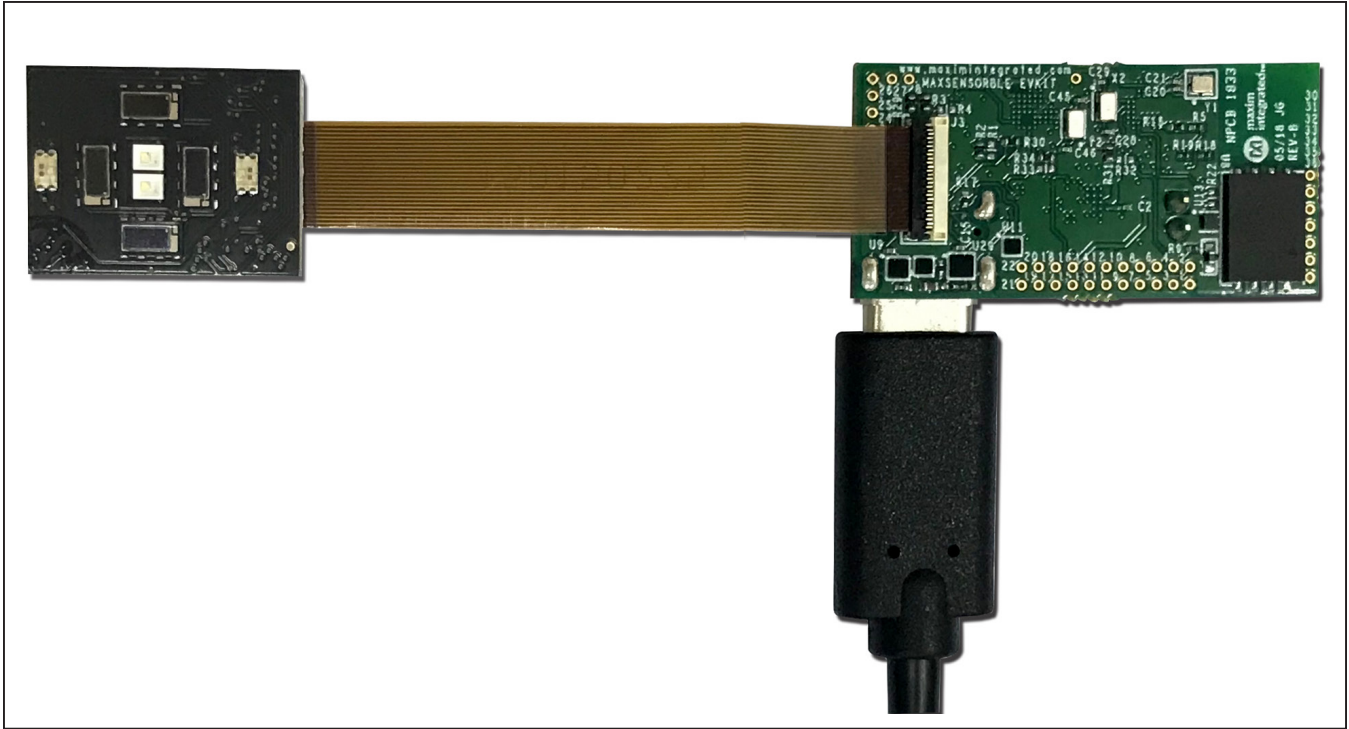

Figure 10. Hardware Setup (MAX86171 EV Sys Sensor PCB)

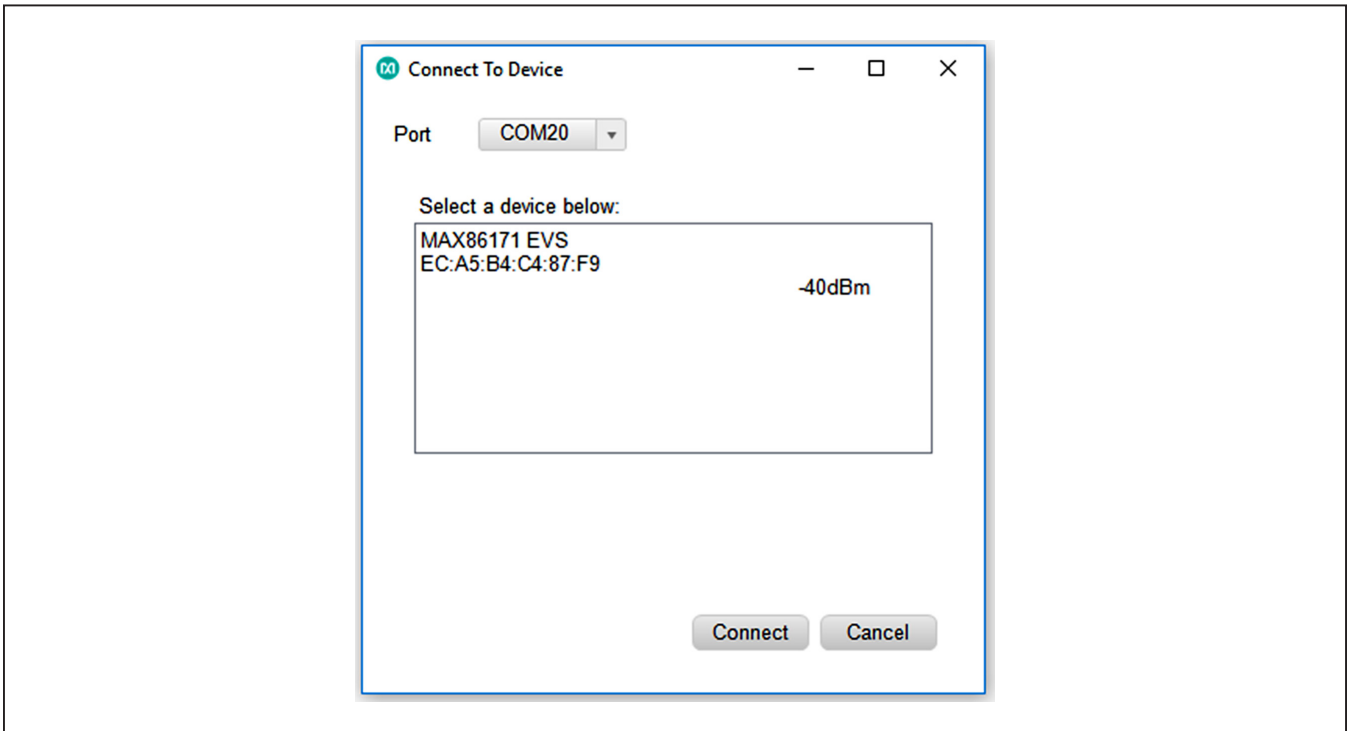

Figure 11. Connect to BLE Device

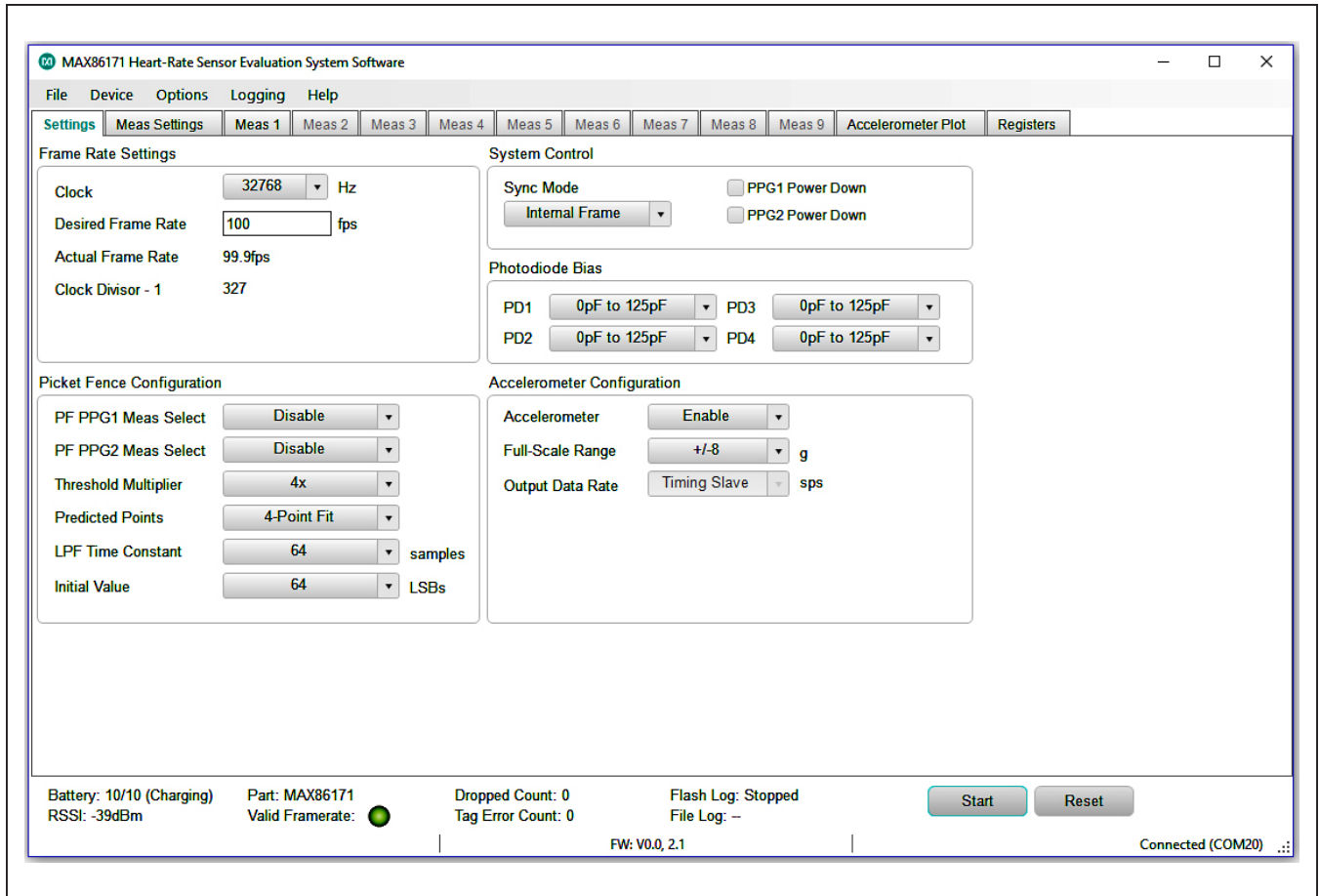

Figure 12. MAX86171 EV Sys GUI Settings

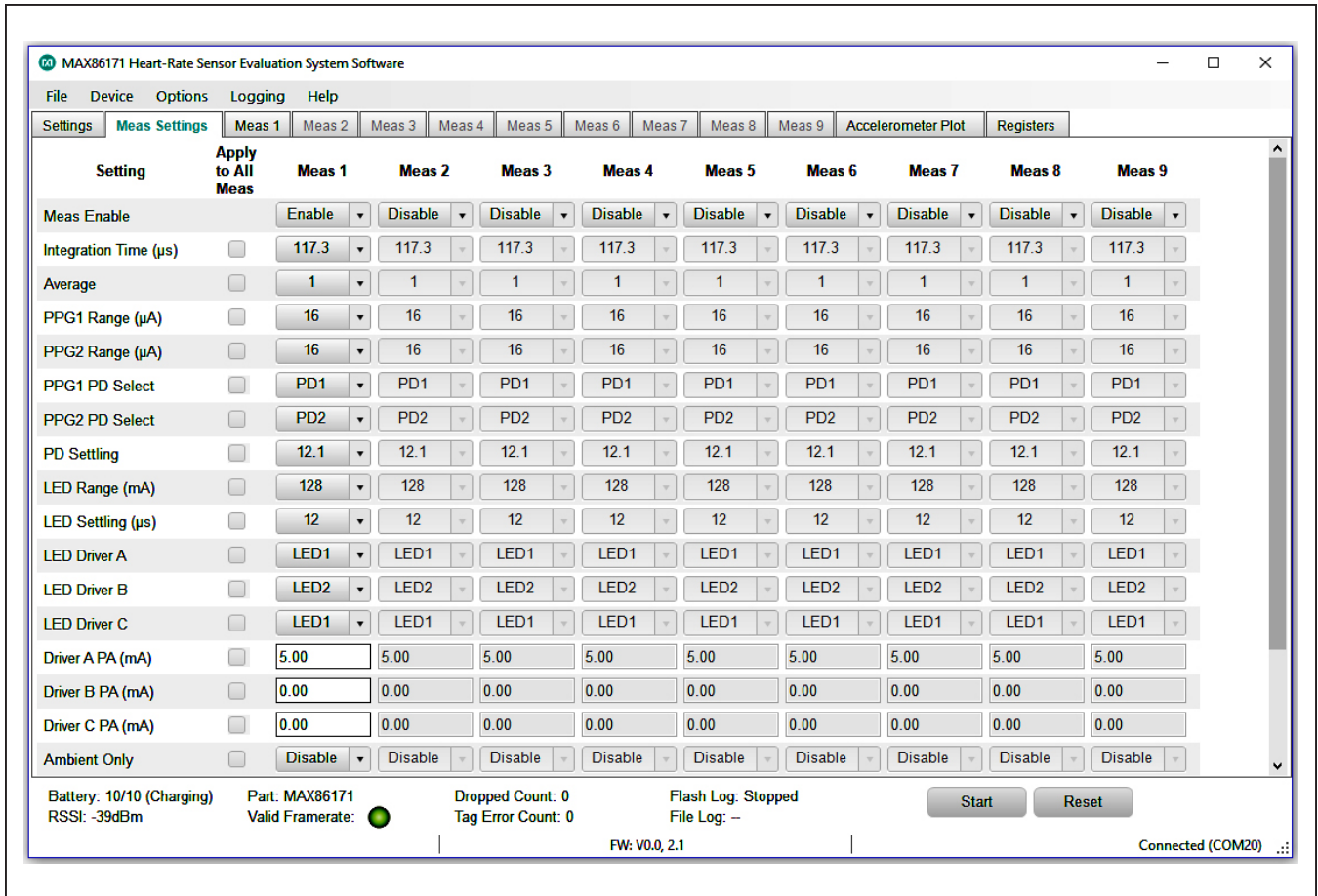

Figure 13. MAX86171 EV Sys GUI Measurement Settings

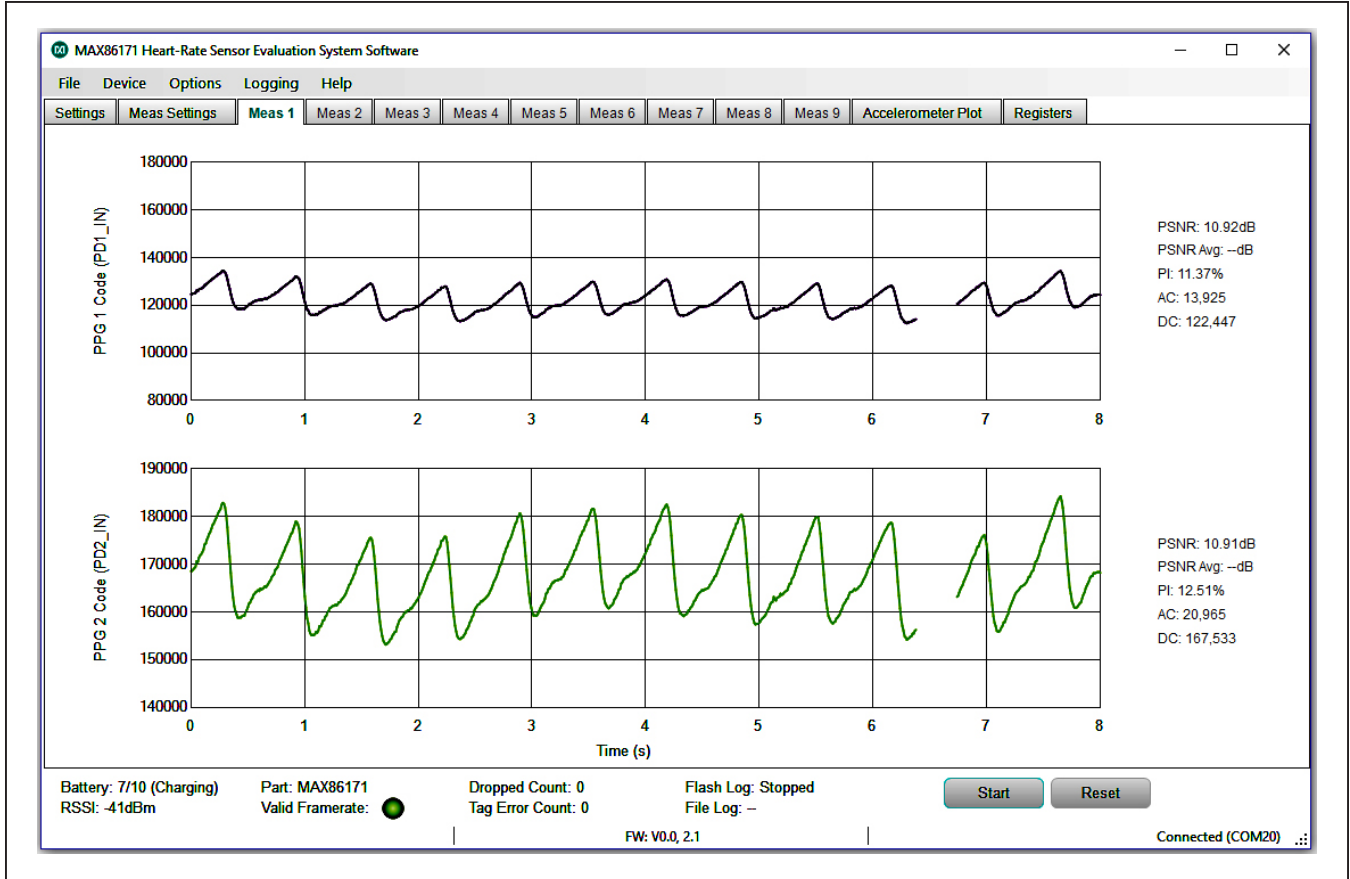

Figure 14. MAX86171 EV Sys GUI (PPG Plots)

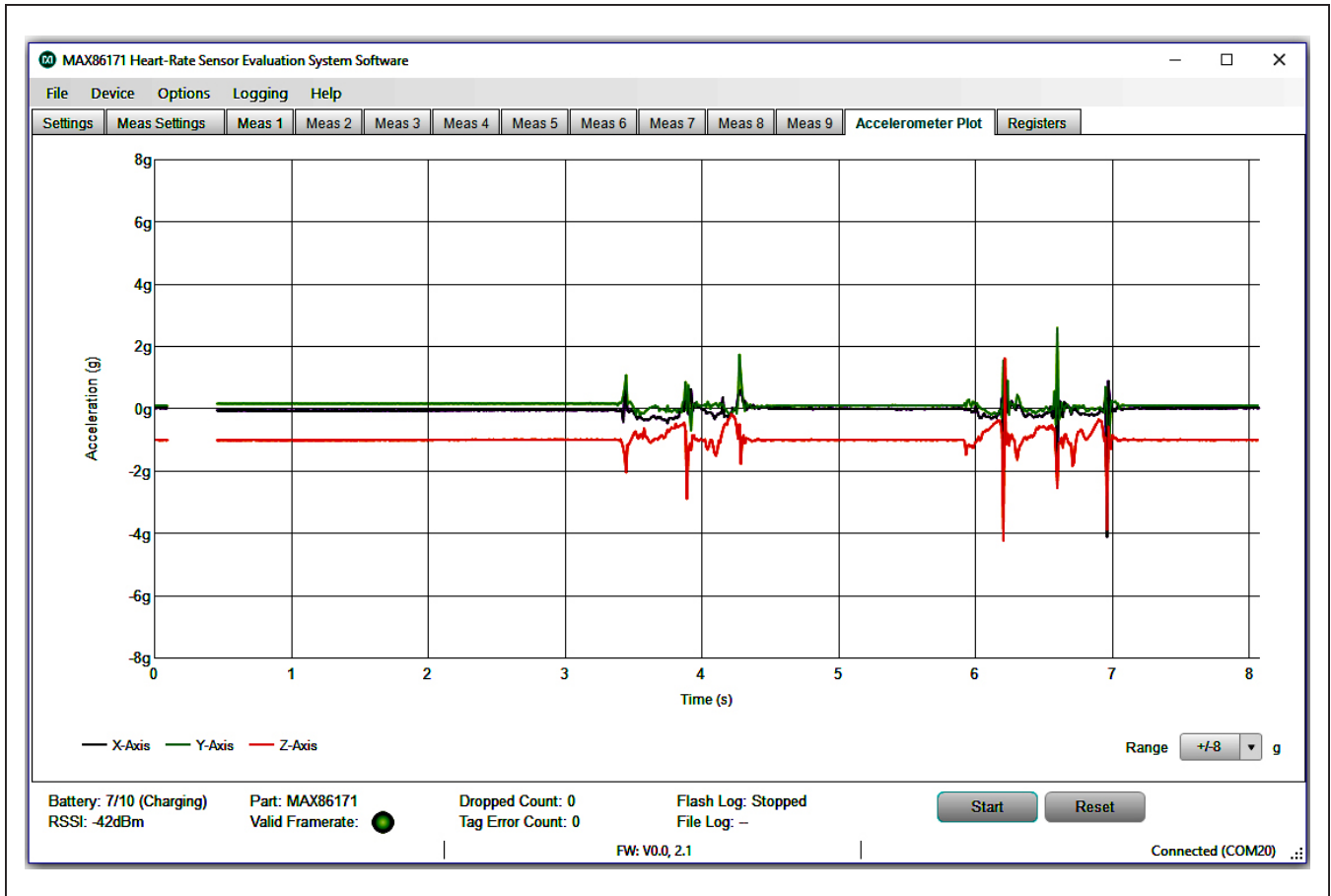

Figure 15. MAX86171 EV Sys GUI (Accelerometer Plots)

Detailed Description of Software

The EV sys includes one sensor PCB. It contains MAX86171 optical AFE, a 3-axis accelerometer together with four photodiodes and 8 LEDs (in 4 LED packages). MAX86171_OSB# comes with 4 discrete photodiodes (Vishay VEMD8080), 2 Red/IR/Green LED packages (Osram SFH 7013) and 2 green LEDs (Osram CT DBLP31.12-6C5D-56-J6U6). The EV sys allows raw optical and accelerometer data to be sampled and transferred to the GUI for both dynamic viewing and logging for later analysis. The EV sys microcontroller PCB is used to do SPI to BLE communication, transporting the raw optical and accelerometer data to the PC through BLE.

Most functionality of the MAX86171 has been mapped to the GUI so the wide variety of applications supported by the MAX86171 can be rapidly explored. The following is a brief description of this functionality options.

Frame Rate

Frame rate defines how frequently a frame is repeated. Frame is a collection of measurements that can have a minimum of 1 measurement and a maximum of 9 measurements. The frame rate can take on any value from 1fps to 2.9kfps.

Table 1 shows the maximum supported frame rates (in fps) for the MAX86171 for the given number of measurements and use of accelerometer. The maximum frame rate is limited by the BLE protocol, not the AFE itself.

Table 1. MAX86171 Max Frame Rates (fps)

| MAXIMUM FRAME RATE | WITH ACCELEROMETER | | WITHOUT ACCELEROMETER | |
|------------------------|--------------------|------|-----------------------|------|
| | 1 PD | 2 PD | 1 PD | 2PD |
| NUMBER OF MEASUREMENTS | | | | |
| 1 | 500 | 500 | 1000 | 1000 |
| 2 | 500 | 250 | 1000 | 500 |
| 3 | 250 | 125 | 500 | 250 |
| 4 | 250 | 125 | 500 | 125 |
| 5 | 125 | 125 | 250 | 125 |
| 6 | 125 | 62.5 | 250 | 125 |
| 7 | 125 | 62.5 | 125 | 62.5 |
| 8 | 125 | 62.5 | 125 | 62.5 |
| 9 | 125 | 62.5 | 125 | 62.5 |

Picket Fence Configuration

Under typical situations, the rate of change of ambient light is such that the ambient signal level during exposure can be accurately predicted and high levels of ambient rejection are obtained. However, it is possible to have situations where the ambient light level changes extremely rapidly, for example when in a car with direct sunlight exposure passes under a bridge and into a dark shadow. In these situations, it is possible for the on-chip ambient light correction (ALC) circuit to fail and produce an erroneous estimation of the ambient light during the exposure interval. The optical controller has a built-in algorithm, called the picket fence function, that can correct for these extreme conditions on the ALC circuit.

Refer to the *MAX86171 data sheet* under Picket Fence Detect-and-Replace Function Section for details.

System Control

There is option to power down one of the PPG readout channels or use dual PPG channels simultaneously. When dual PPG channels are used, the data log will show data from both PDs for each configured measurement.

Photodiode Bias

The MAX86171 provides multiple photodiode biasing options. These options allow the MAX86171 to operate with a large range of photodiode capacitance. The PDBIAS values adjust the PD_IN bias point impedance to ensure that the photodiode settles rapidly enough to support the sample timing. PDBIAS is configured depending on the capacitance of the photodiode used.

Accelerometer Configuration

The on-board accelerometer can be enabled or disabled by using the GUI. Supported accelerometer Full-Scale Ranges are ±2g, ±4g, and ±8g. The output data of the accelerometer can also be configured from 15.63Hz to 2000Hz when used with Sync Mode of External Clock or External Frame.

Measurements Enable

The Measurement Enable specifies the data acquisition sequence that the internal state machine controller will follow and where the converted data will be mapped into the FIFO.

Each FIFO field can be applied to one measurement. Acquired data can be from LED1~9 (optical exposure from LED1~9) illuminated independently. The other options are Ambient (optical data with no exposure, just ambient illumination) or Disable (skip this acquisition).

MAX86171 supports up to nine measurements per frame. Each of the nine measurements are configured in the MEAS1 setup to Meas9 Setup registers. Any measurement can be enabled and the measurements do not need to be contiguous. If direct ambient needs to be measured, it should always be the last enabled measurement in the frame.

This enabled measurements sequence will repeat for each frame. Each Measurement if enabled will be plotted in the Meas x (x = 0...9) tabs respectively as shown in [Figure 14](#).

Please refer to the *MAX86171 data sheet* under System Control and MEASx Setup Sections for details.

Integration Time

The MAX86171 supports exposure integration times of 14.8 μ s, 29.4 μ s, 58.7 μ s, and 117.3 μ s. The exposure pulse width is a critical parameter in any optical measurement. Longer exposures allow for more optical photons to be integrated but also increase system power and reduce ambient rejection capability.

Measurement Average

The MAX86171 has the capability to do sample averaging of 2 ~ 128 samples internally. This feature is useful if more optical energy is needed to make a low perfusion measurement but the data rate across the interface or the processing power in a host micro is not desirable.

PPG Range

The MAX86171 optical channel has 4 ADC full-scale ranges. These ranges are 4 μ A, 8 μ A, 16 μ A, and 32 μ A.

PPG PD Select

There are 2 PPG readout ADC channels. These 2 PPG readout channels can support up to 4 photodiodes. PPG channel 1 can be mux-ed to PD1 or PD3 and PPG Channel 2 can be mux-ed to PD2 or PD4.

LED Driver Configurations

In each Measurement, the three LED drivers have a Range. There are 4 full-scale range settings 31mA, 62mA, 93mA and 124mA.

Each of the three LED drivers has a LED Pulse Amplitude Current setting. Each measurement can drive one, two, or all three LED drivers. This configuration of LED driver and LED mux is highly flexible, allowing for any of the nine LED driver pins to sink current from one LED driver (or 2 LED drivers for LED1, LED2, LED3). Each LED driver has an 8-bit current source DAC. The Peak LED Current box allows for an actual current to be entered. The near-

est available DAC current is selected and displayed in the field.

LED Settling Time

The LED Settling Time is the time prior to the start of Integration Time that the LED is turned on. There are four settlings, 24 μ s, 18 μ s, 12 μ s and 6 μ s. This time is necessary to allow the LED driver to settle before integrating the exposure photo current.

Ambient Light Cancellation

The on-chip Ambient Light Cancellation incorporates a proprietary scheme to cancel ambient light generated photodiode current, allowing the sensor to work in high ambient light conditions.

PPG Offset

Each optical signal path also incorporates a 2-bit offset DAC for extending the optical dynamic range. This allow for a larger convertible exposure range by sourcing some of the exposure current from the offset DAC.

<Start>/<Stop> Button

The <Start> button is used to start data acquisition from the demo. The <Start> button will only be effective when the EV sys is connected and detected. Once the <Start> has been pushed the <Stop> button appears, which can be used to stop the acquisition. Once the acquisition has started, all settings are locked. Terminate the acquisition to change any settling.

<Reset> Button

The <Reset> button will clear out all register settlings back to the programs start up.

Data Logging

Raw optical and accelerometer data can be logged from the <Logging> pull-down menu item. There are two options available: Data saved to file or in the flash. When "file" data logging is selected, the GUI asks for a folder location where the logging file will be saved. Create a new folder or accept the default. Data logging will start on the next <Start> button and will continue until the <Stop> button is pressed. The final file write is only done when the <File> pull-down menu item is accessed and the data-logging button is pressed.

Flash logging allows raw sensor data to be stored to the integrated 32MB flash memory chip in a binary file format. The max duration for flash logging is dependent on: frame rate, number of optical channels, and use of accelerometer.

The GUI enables/disables flash logging. The GUI can be disconnected while flash logging, allowing for remote operation (PPG Plots not available). Preparing the flash memory can take up to 30s after enabling. If the flash memory fills or battery power drops too low, flash logging will automatically stop and the file will close. Only one file can be saved at a time. The file must be downloaded since it will be erased on the next log request.

If a log has completed, a binary file will be found on the device. The binary log file must be downloaded through the USB-C cable; it cannot be downloaded through BLE. When the device is plugged into the PC, it enumerates as a USB mass storage device. However, the file can only be copied from this device. No other operations (such as deleting or saving other files) will work on this device.

Copy the file to a local PC volume. Then run the parser under the Logging menu to generate a CSV file.

Please refer to the Evaluation Kit Parser User Guide (MAX86171 demo + eval kit parser user guide.pdf) for details operation.

Register Map Access

Under the <Register> Tab the user can access to sensor register map as shown in [Figure 16](#). Press <Read All>, to read all the register value currently in configured in the Optical AFE. Bolded font bits are logic one. Normal font bits are logic zero. Click on the bits to toggle their value and click on <W> to write the value to the device. The register value does not change until <W> is clicked. Click <R> to read the register value to verify the write.

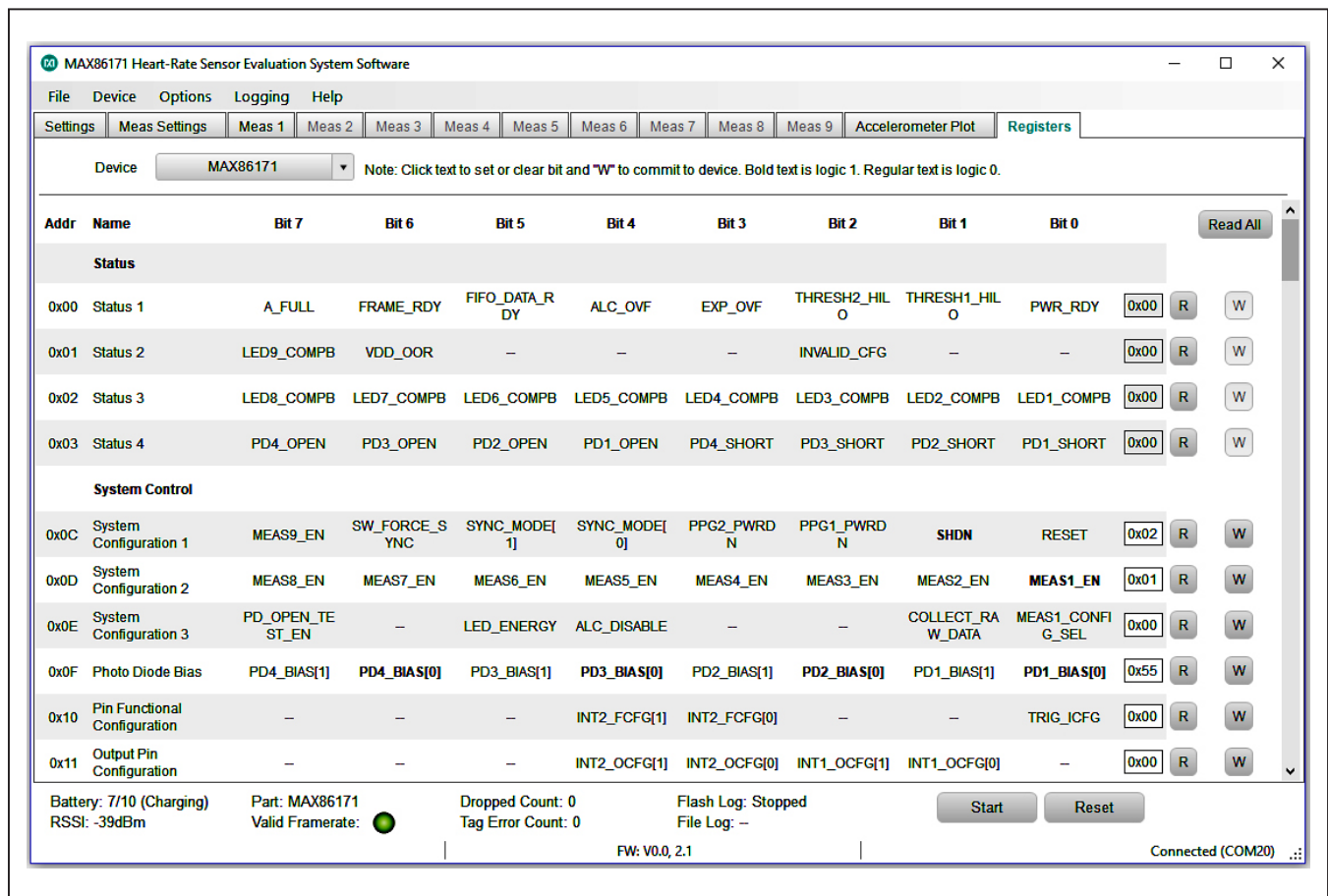

Figure 16. Register Map Access

Detailed Description of Hardware

Status LED Indicators

The onboard tri-color LEDs are use as status indicator.

LED Green

Toggling (1Hz 50% duty cycle) = BLE advertising

Toggling (1Hz 10% duty cycle) = BLE connected

LED Red

USB-C cable connected to charger

On = charging

Off = charge complete

Flash Logging

On = busy preparing the flash memory or flash memory is full

Toggling (synchronously with the green LED) = logging

Off = not logging

Ordering Information

| PART | TYPE |
|----------------|--------|
| MAX86171EVSYS# | EV Sys |

#Denotes RoHS compliant.

Note that flash logging indication takes precedence over the charging indication. (i.e., if the device is plugged into a charger, the red LED indicates charge status). If flash logging is enabled while plugged into the charger, the red LED indicates flash log status.

Power Switch

Press the power switch (SW) to turn on/off the device. When powered on, the green LED will toggle per the LED indicator section. When powered off, the green LED will go out. The red LED may light temporarily, indicating that the flash log is closing. Plugging in the USB-C cable will also power up the device.

Battery/Charging

Use the USB-C cable to charge the integrated single-cell LiPo battery. The integrated PMIC initiates and stops charging automatically. Charge status is indicated through the red LED and GUI.

Component List

MAX86171 EV Sys

| PART | QTY | DESCRIPTION |
|-----------------|-----|-----------------------------|
| MAXSensorBLE# | 1 | MAX86171 EV Sys μ C PCB |
| MAX86171_OSB# | 1 | MAX86171 EV Sys Sensor PCB |
| 150150225 | 1 | Molex, Flex Cable, 25 Pins |
| CY5677 | 1 | Cypress, BLE Dongle |
| 101181XX-000XXX | 1 | USB-C to USB-A Cable, 3 Ft. |

MAX86171 EV Kit Bill of Materials

MAXSENSORBLE#

| ITEM | QTY | REF DES | DNI/DNP | MFG PART # | MANUFACTURER | VALUE | DESCRIPTION |
|------|-----|-------------------------------------|---------|---|----------------------------|--------------------|---|
| 1 | 1 | A1 | — | 2450AT18A100 | JOHANSON TECHNOLOGY | 2450AT18A100 | ANTENNA: 2450AT SERIES; BOARDMOUNT; MINI 2.45 GHZ ANTENNA; 2450MHz |
| 2 | 1 | BAT | — | B2B-PH-K-S(LF)(SN) | JST MANUFACTURING | B2B-PH-K-S(LF)(SN) | CONNECTOR: MALE; THROUGH HOLE; PH CONNECTOR; 2MM PITCH; SHROUDED HEADER; STRAIGHT; 2PINS |
| 3 | 11 | C1, C22, C26, C30-C37 | — | GRM033R61A104KE15; LMK063BJ104KP | MURATA;TAIYO YUDEN | 0.1µF | CAPACITOR: SMT (0201); CERAMIC CHIP; 0.1µF; 10V; TOL=10%; MODEL = ; TG = -55°C TO +125°C; TC = X5R |
| 4 | 9 | C2, C15, C25, C38-C43 | — | GRM033R61A105ME15 | MURATA | 1µF | CAPACITOR: SMT (0201); CERAMIC CHIP; 1µF; 10V; TOL = 20%; TG = -55°C TO +85°C; TC = X5R |
| 5 | 7 | C3, C4, C8, C9, C12, C16, C27 | — | ZRB15XR61A475ME01; CL05A475MP5NRN; GRM155R61A475MEAA; C1005X5R1A475M050BC | MURATA;SAMSUNG; MURATA;TDK | 4.7µF | CAPACITOR: SMT (0402); CERAMIC CHIP; 4.7µF; 10V; TOL=20%; TG = -55°C TO +85°C; TC = X5R |
| 6 | 7 | C5-C7, C10, C13, C14, C47 | — | GRM155R60J226ME11 | MURATA | 22µF | CAPACITOR: SMT (0402); CERAMIC CHIP; 22µF; 6.3V; TOL = 20%; TC = X5R ; NOTE: THESE PARTS HAVE 52 WEEKS LEAD TIME; MANUFACTURING DELAYS HAVE BEEN REPORTED ON THIS PRODUCT |
| 7 | 1 | C19 | — | GJM0335C1E1R0WB01 | MURATA | 1PF | CAPACITOR: SMT (0201); CERAMIC CHIP; 1PF; 25V; TOL = 0.05PF; TG = -55°C TO +125°C; TC = C0G |
| 8 | 7 | C20, C21, C28, C29, C45, C46, Z44 | — | GRM0335C1H120GA01 | MURATA | 12PF | CAPACITOR: SMT (0201); CERAMIC CHIP; 12PF; 50V; TOL = 2%; TG = -55°C TO +125°C; TC = C0G |
| 9 | 2 | C23, C24 | — | GRM0335C1H101JA01 | MURATA | 100PF | CAPACITOR: SMT (0201); CERAMIC CHIP; 100PF; 50V; TOL = 5%; TG = -55°C TO +125°C; TC = C0G |
| 10 | 1 | CN1 | — | DX07S024JJ3R1300 | JAE ELECTRONIC INDUSTRY | DX07S024JJ3 | CONNECTOR: FEMALE; SMT; USB TYPE-C CONNECTOR; DX07 SERIES RECEPTACLE; RIGHT ANGLE; 24PINS |
| 11 | 2 | DS1, DS2 | — | SML-P11UTT86 | ROHM | SML-P11UTT86 | DIODE; LED; SMT; PIV = 1.8V; IF = 0.02A |
| 12 | 1 | J3 | — | 5035662500 | MOLEX | 5035662500 | CONNECTOR: FEMALE; SMT; EASY-ON TYPE HOUSING ASSEMBLY; RIGHT ANGLE; 25PINS |
| 13 | 2 | L1, L2 | — | DFE185BN2R2MELL | MURATA | 2.2UH | EVKIT PART - INDUCTOR; SMT (0603); SHIELDED; 2.2µH; 20%; 1.2A |
| 14 | 1 | L3 | — | DFE201610E-4R7M=P2 | MURATA | 4.7UH | INDUCTOR; SMT (2016); METAL ALLOY CHIP; 4.7µH; TOL = ±20%; 1.3A |
| 15 | 1 | L4 | — | LQP03HQ3N3B02 | MURATA | 3.3NH | INDUCTOR; SMT (0201); FILM TYPE; 3.3NH; TOL = ±0.1nH; 0.5A |
| 16 | 1 | LED | — | SML-LX0404SIUPGUSB | LUMEX OPTO COMPONENTS INC | SML-LX0404SIUPGUSB | DIODE; LED; SML; FULL COLOR; WATER CLEAR LENS; RED-GREEN-BLUE; SMT; VF = 2.95V; IF = 0.1A |
| 17 | 11 | R2, R3, R11, R15, R24, R27-R31, R34 | — | ERJ-2GEOR00 | PANASONIC | 0 | RESISTOR; 0402; 0Ω; 0%; JUMPER; 0.10W; THICK FILM |
| 18 | 2 | R5, R9 | — | ERJ-1GEF1002 | PANASONIC | 10K | RESISTOR; 0201; 10KΩ; 1%; 200PPM; 0.05W; THICK FILM |
| 19 | 7 | R6, R7, R16, R17, R23, R25, R26 | — | ERJ-1GEF4701C | PANASONIC | 4.7K | RESISTOR; 0201; 4.7KΩ; 1%; 100PPM; 0.05W; THICK FILM 3-LAYER ELECTRODE |
| 20 | 1 | R8 | — | ERJ-1GEF3902 | PANASONIC | 39K | RESISTOR; 0201; 39KΩ; 1%; 100PPM; 0.05W; THICK FILM 3-LAYER ELECTRODE |
| 21 | 1 | R10 | — | NCP15XH103F03 | MURATA | 10K | THERMISTOR: SMT (0402); THICK FILM (NICKEL PLATED); 10K; TOL = ±1% |
| 22 | 1 | R13 | — | ERJ-1GEF2613C | PANASONIC | 261K | RESISTOR; 0201; 261KΩ; 1%; 200PPM; 0.05W; THICK FILM |
| 23 | 1 | R14 | — | CRCW0201100KFK | VISHAY DALE | 100K | RESISTOR; 0201; 100KΩ; 1%; 100PPM; 0.05W; THICK FILM |
| 24 | 2 | R18, R19 | — | ERJ-1GEF2000C | PANASONIC | 200 | RESISTOR; 0201; 200Ω; 1%; 200PPM; 0.05W; THICK FILM |
| 25 | 4 | RA1-RA4 | — | ERJ-1GEF33R0C | PANASONIC | 33 | RESISTOR; 0201; 33Ω; 1%; 100PPM; 0.05W; THICK FILM 3-LAYER ELECTRODE |
| 26 | 1 | SW | — | EVP-AWCD2A | PANASONIC | EVP-AWCD2A | SWITCH; SPST; SMT; STRAIGHT; 15V; 0.02A; EVP-AW SERIES |
| 27 | 1 | U1 | — | MAX20303KEWN+ | MAXIM | MAX20303KEWN+ | EVKIT PART - IC; WEARABLE POWER NAMAGEMENT SOLUTION; PACKAGE OUTLINE: WLP 56 PINS; 0.5MM PITCH; PKG. CODE: W5634A+1; PKG. OUTLINE: 21-100104 |
| 28 | 1 | U2 | — | NRF52832-CIAA | NORDIC SEMICONDUCTOR | NRF52832-CIAA | IC; SOC; MULTIPROTOCOL BLUETOOTH LOW ENERGY; ANT; 2.4GHZ RF SOC; WLCSF50 |

MAX86171 EV Kit Bill of Materials (continued)

MAXSENSORBLE#

| ITEM | QTY | REF DES | DNI/DNP | MFG PART # | MANUFACTURER | VALUE | DESCRIPTION |
|--------------|------------|--------------------------------|---------|-------------------|-----------------------|------------------|--|
| 29 | 5 | U3-U6, U9 | — | MAX14689EWL+ | MAXIM | MAX14689EWL+ | IC; ASW; 0.125A; FREQUENCY-SELECTSBLE; SWITCHED-CAPACITOR VOLTAGE CONVERTER; WLP9 1.2X1.2 |
| 30 | 1 | U7 | — | IP4221CZ6-S | NXP | IP4221CZ6-S | IC; PROT; ESD PROTECTION FOR HIGH-SPEED INTERFACE; XSON6 |
| 31 | 1 | U8 | — | S25FS256SAGNF001 | SPANSION | S25FS256SAGNF001 | IC; MMRY; MIRRORBIT FLASH; NON-VOLATILE MEMORY; 1.8V SINGLE SUPPLY WITH CMOS I/O; SERIAL PERIPHERAL INTERFACE WITH MULTI-I/O; WSON8-EP |
| 32 | 2 | U10, U11 | — | MAX9062EBS+G45 | MAXIM | MAX9062EBS+G45 | IC; COMP; ULTRA-SMALL; LOW-POWER SINGLE COMPARATOR; UCSP4 |
| 33 | 1 | U12 | — | MAX32620IWG+ | MAXIM | MAX32620IWG+ | IC; UCON; HIGH-PERFORMANCE; ULTRA-LOW POWER CORTEX-M4F MICROCONTROLLER FOR RECHARGEABLE DEVICES; WLP81 |
| 34 | 1 | U13 | — | 74AUP1G97GF | NXP | 74AUP1G97GF | IC; LOGG; LOW-POWER CONFIGURABLE MULTIPLE FUNCTION GATE; XSON6 |
| 35 | 1 | U29 | — | MAX1819EBL33+ | MAXIM | MAX1819EBL33+ | IC; VREG; 500MA LOW-DROUPOUT LINEAR REGULATOR IN UCSP; UCSP6 |
| 36 | 2 | X2, Y2 | — | ECS-327-6-12 | ECS INC | 32.768KHZ | CRYSTAL; SMT 2.0 MM X 1.2 MM; 6PF; 32.768KHZ; ±20PPM; -0.03PPM/°C2 |
| 37 | 1 | Y1 | — | US3200005Z | PERICOM SEMICONDUCTOR | 32MHZ | CRYSTAL; SMT 1.6 MM X 1.2MM; 8PF; 32MHZ; ±10PPM; ±10PPM |
| 38 | 1 | PCB | — | MAXSENSORBLE | MAXIM | PCB | PCB:MAXSENSORBLE |
| 39 | 0 | R1, R4, R12, R20-R22, R32, R33 | DNP | ERJ-2GE0R00 | PANASONIC | 0 | RESISTOR; 0402; 0Ω; 0%; JUMPER; 0.10W; THICK FILM |
| 40 | 0 | Z17 | DNP | GJM0335C1E1ROWB01 | MURATA | 1PF | CAPACITOR; SMT (0201); CERAMIC CHIP; 1PF; 25V; TOL = 0.05PF; TG = -55°C TO +125°C; TC = C0G |
| 41 | 0 | Z18 | DNP | 250R05L1R8AV4 | JOHANSON TECHNOLOGY | 1.8PF | CAPACITOR; SMT (0201); MICROWAVE; 1.8PF; 25V; TOL=0.05PF; TG = -55°C TO +125°C; TC = C0G |
| 42 | 0 | Jan-36 | DNP | N/A | N/A | N/A | TEST POINT; PAD DIA = 0.762MM; BOARD HOLE = 0.381MM |
| TOTAL | 104 | | | | | | |

MAX86171 EV Kit Bill of Materials (continued)

MAX86171_OSB#

| ITEM | QTY | REF DES | DNI/DNP | MFG PART # | MANUFACTURER | VALUE | DESCRIPTION |
|--------------|-----------|------------------------------|---------|-----------------------------|------------------------|---------------------------|--|
| 1 | 8 | C1-C6, C10, C11 | — | GRM155R60J226ME11 | MURATA | 22µF | CAPACITOR; SMT (0402); CERAMIC CHIP; 22µF; 6.3V; TOL = 20%; TC = X5R; NOTE: THESE PARTS HAVE 52 WEEKS LEAD TIME; MANUFACTURING DELAYS HAVE BEEN REPORTED ON THIS PRODUCT |
| 2 | 3 | C7-C9 | — | GRM033R61A105ME15 | MURATA | 1µF | CAPACITOR; SMT (0201); CERAMIC CHIP; 1µF; 10V; TOL = 20%; TG = -55°C TO +85°C; TC = X5R |
| 3 | 2 | D1, D2 | — | SFH 7013 | OSRAM | SFH 7013 | DIODE; LED; RED; GREEN; INFRARED; SMT; VF = 2.1V; 3V; 1.3V; IF = 0.04A; 0.03A; 0.06A; NOTE: ORDERED DIRECTLY FROM MANUFACTURER |
| 4 | 2 | D3, D4 | — | CT DBLP31.12-6C5D-56-J6U6 | OSRAM | CT DBLP31.12-6C5D-56-J6U6 | DIODE; LED; GREEN; SMT; VF = 2.3V; IF = 0.02A |
| 5 | 1 | J1 | — | 5016162575 | MOLEX | 5016162575 | CONNECTOR; FEMALE; SMT; EASY-ON TYPE FPC CONNECTOR; RIGHT ANGLE; 25PINS |
| 6 | 4 | PD1-PD4 | — | VEMD8080 | VISHAY SEMICONDUCTORS | VEMD8080 | EVKIT CUSTOM - DIODE; SILICON PIN PHOTODIODE; SMT; VR = 20V; IR = 0.00001A |
| 7 | 14 | R1-R3, R4A-R8A, R9-R13, R14A | — | CRCW02010000ZS; ERJ-1GNOR00 | VISHAY DALE; PANASONIC | 0 | RESISTOR; 0201; 0Ω; 0%; JUMPER; 0.05W; THICK FILM |
| 8 | 1 | U1 | — | MAX86171 | MAXIM | MAX86171 | EVKIT PART- IC; WLP28; 0.35MM PITCH; PKG. CODE: N281A2+1; PKG. DWG. NO.: 21-100259 |
| 9 | 1 | U2 | — | BMA280 | BOSCH | BMA280 | IC; SNSR; 14 BIT DIGITAL TRIAXIAL ACCELERATION SENSOR WITH INTELLIGENT ON-CHIP MOTION-TRIGGERED INTERRUPT CONTROLLER; LGA12 |
| 10 | 1 | PCB | — | MAX86171OSB | MAXIM | PCB | PCB:MAX86171OSB |
| 11 | 0 | R4B-R8B, R14B, R15 | DNP | CRCW02010000ZS; ERJ-1GNOR00 | VISHAY DALE; PANASONIC | 0 | RESISTOR; 0201; 0Ω; 0%; JUMPER; 0.05W; THICK FILM |
| TOTAL | 37 | | | | | | |

MAX86171 EV Kit Schematics

MAXSensorBLE

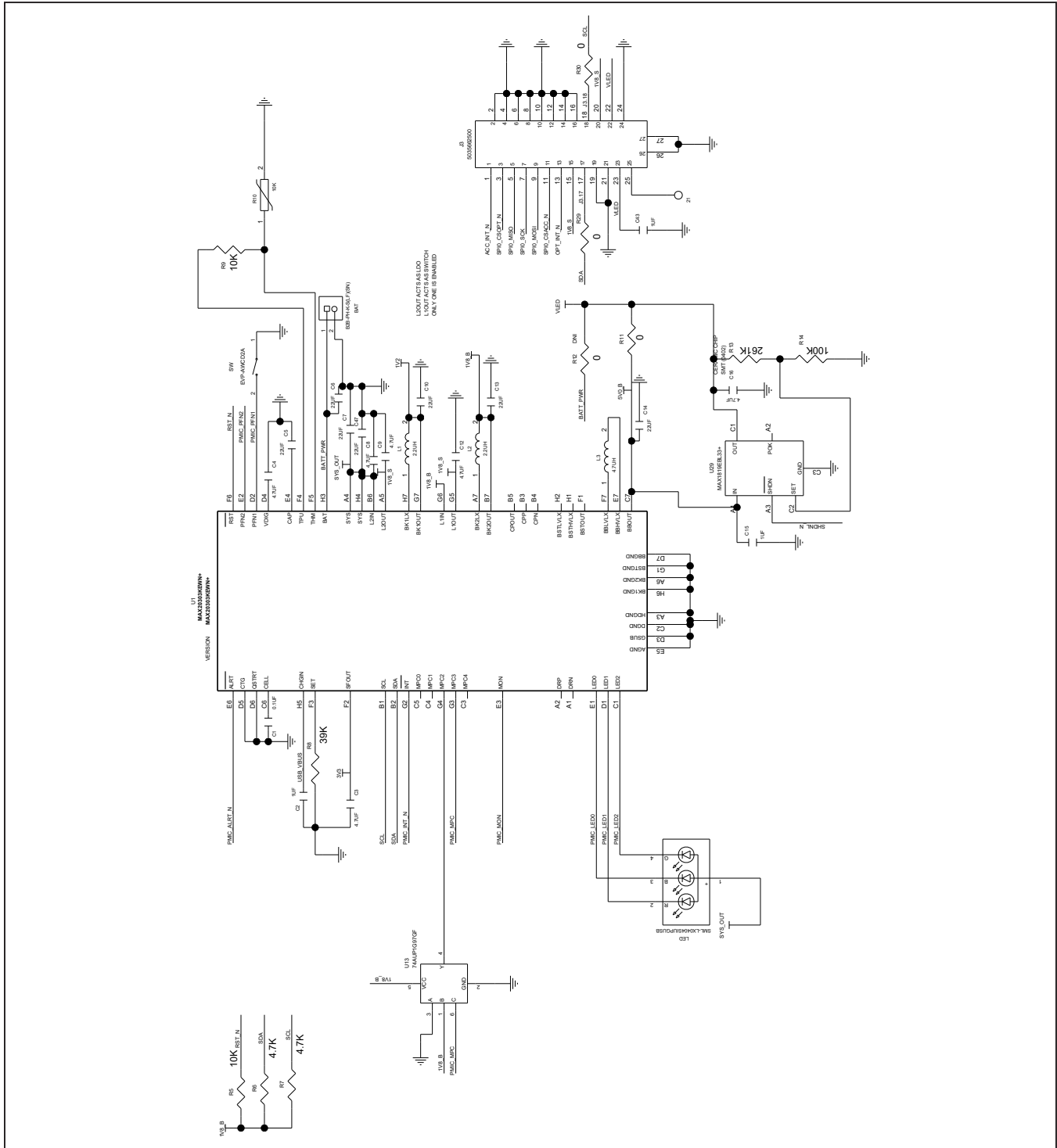

MAX86171 EV Kit Schematics (continued)

MAXSensorBLE

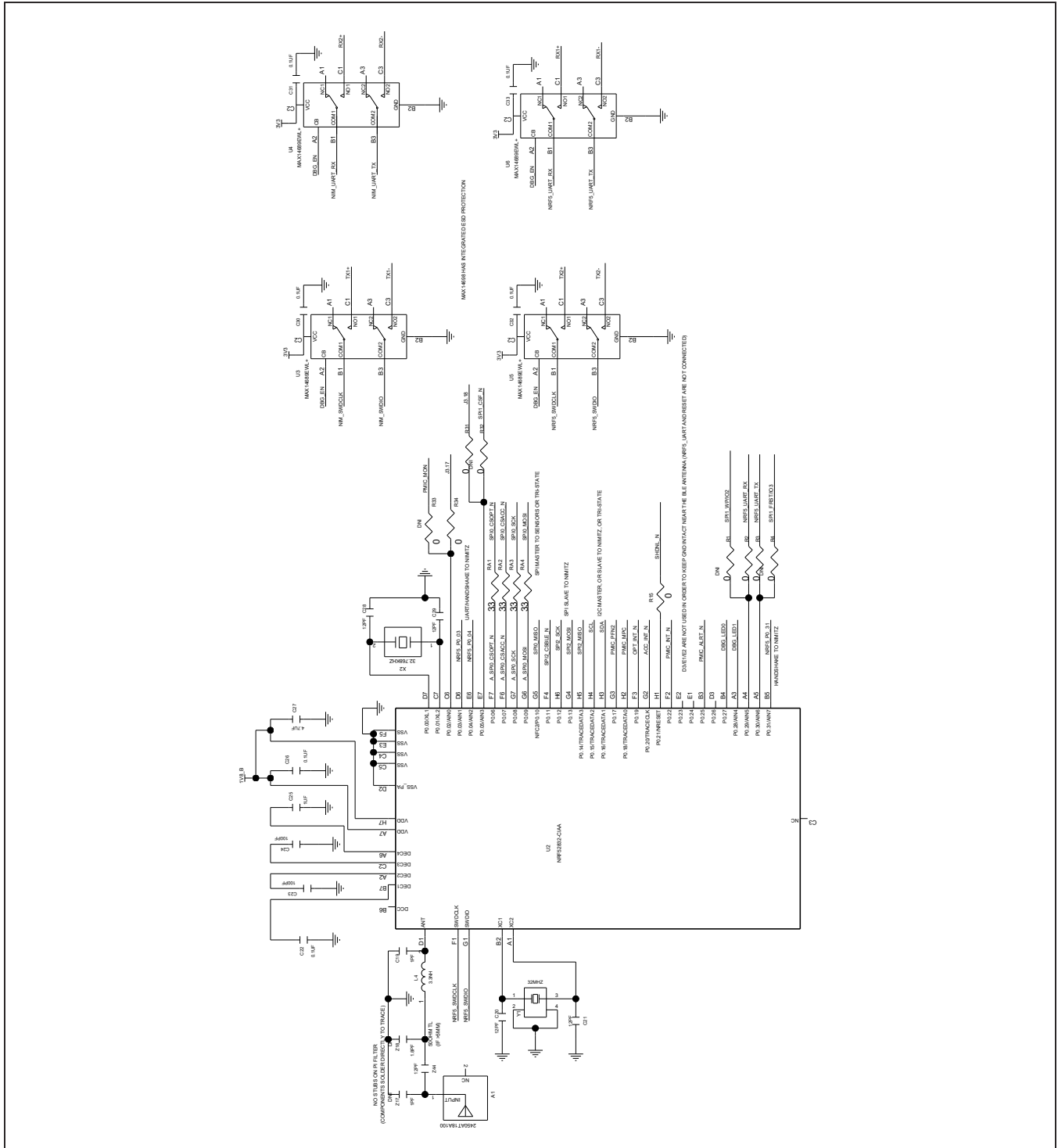

MAX86171 EV Kit Schematics (continued)

MAXSensorBLE

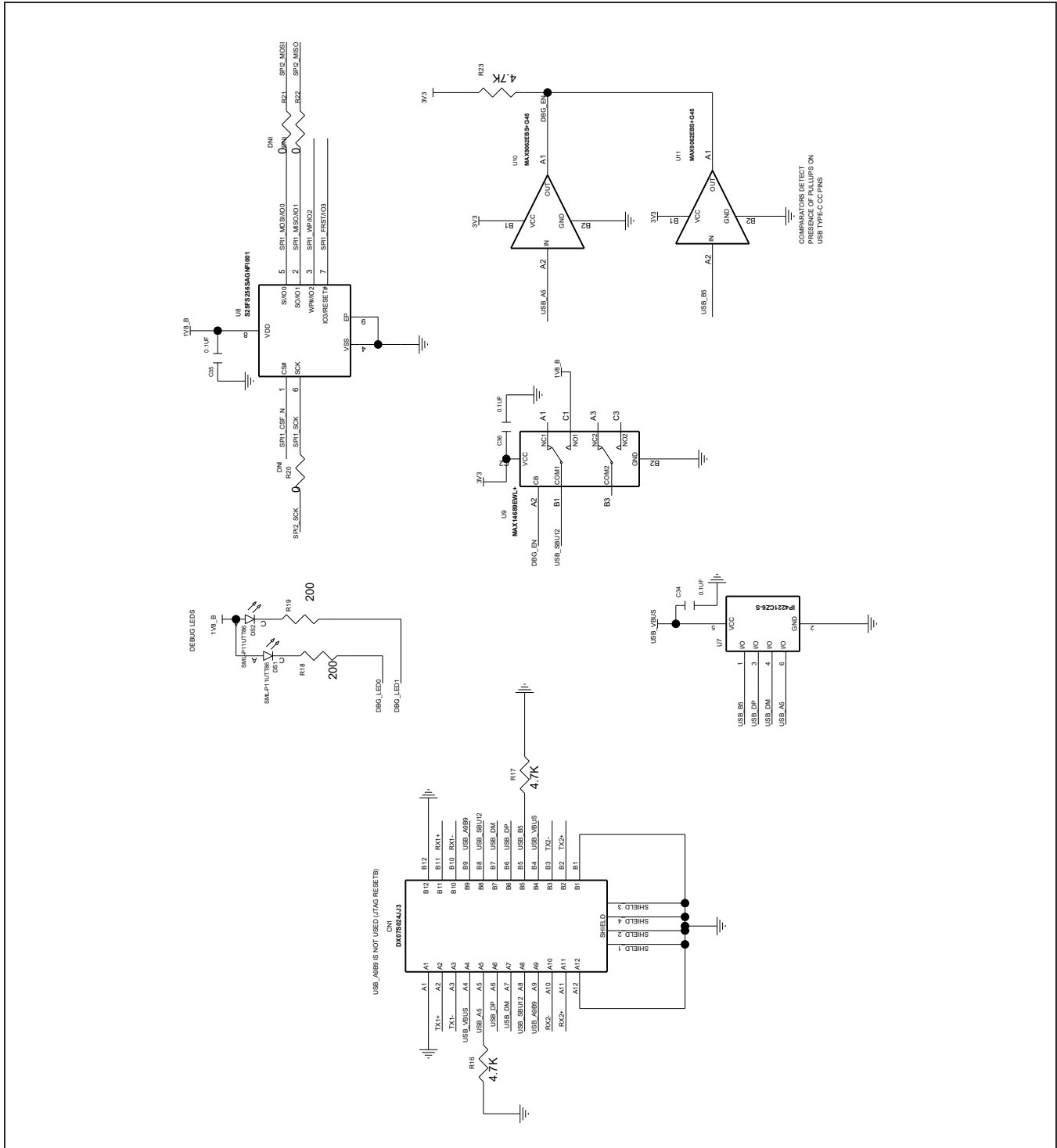

MAX86171 EV Kit Schematics (continued)

MAXSensorBLE

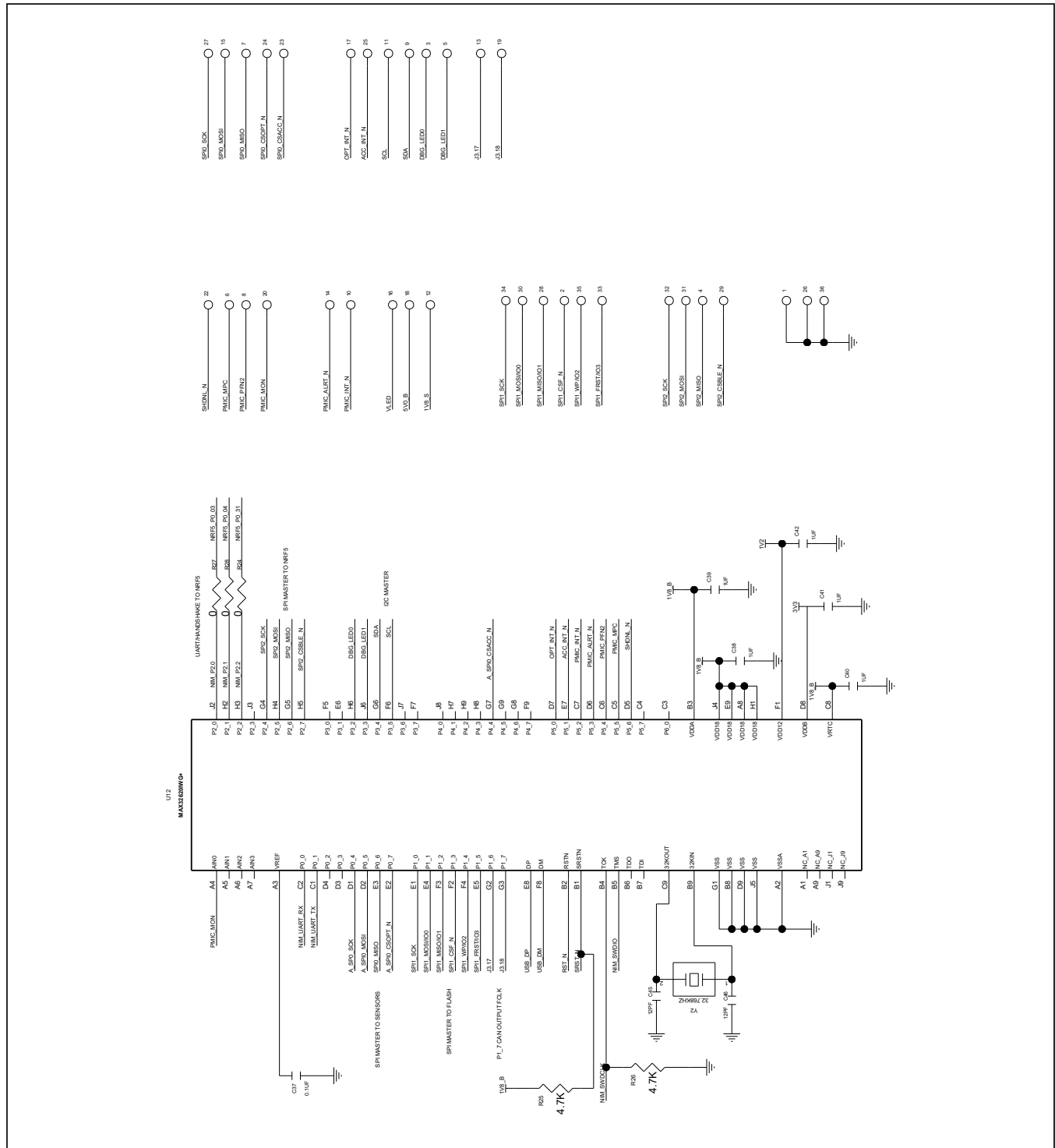

MAX86171 EV Kit Schematics (continued)

MAX86171_OSB#

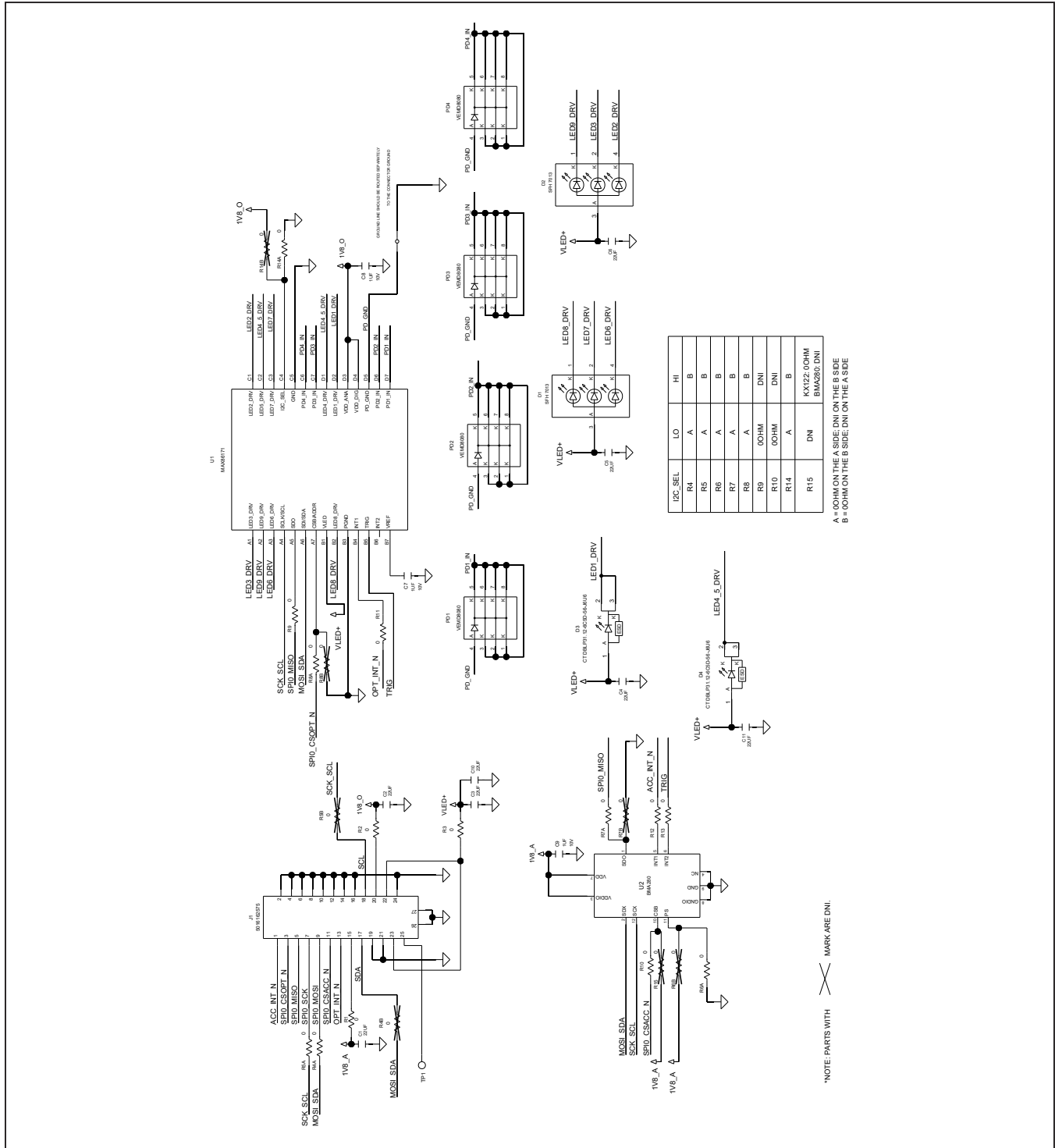

MAX86171 EV Kit PCB Layout Diagrams

MAXSensorBLE_EVKIT

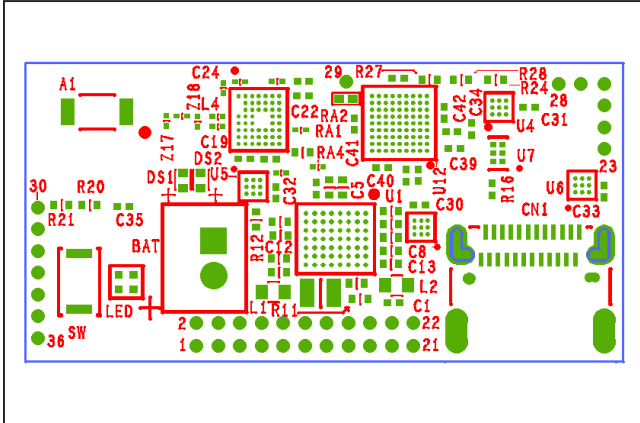

MAXSensorBLE_EVKIT—Top Silkscreen

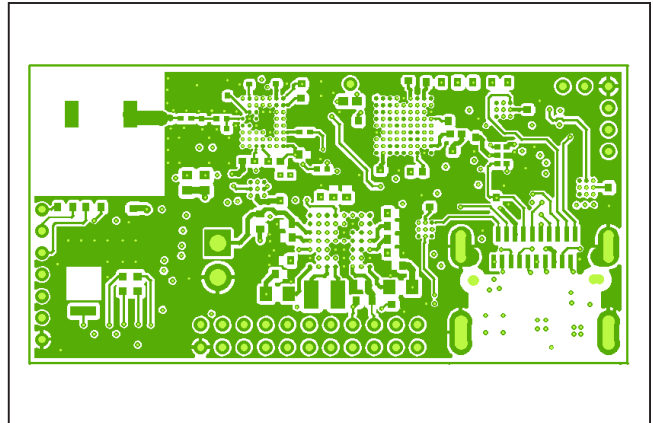

MAXSensorBLE_EVKIT—Top

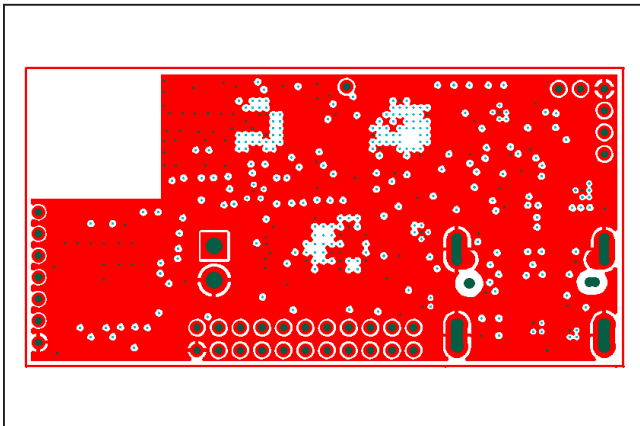

MAXSensorBLE_EVKIT—L02_GND

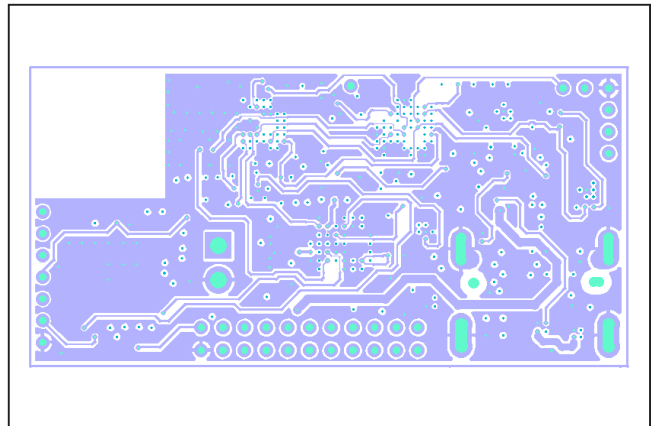

MAXSensorBLE_EVKIT—L03_SIGS

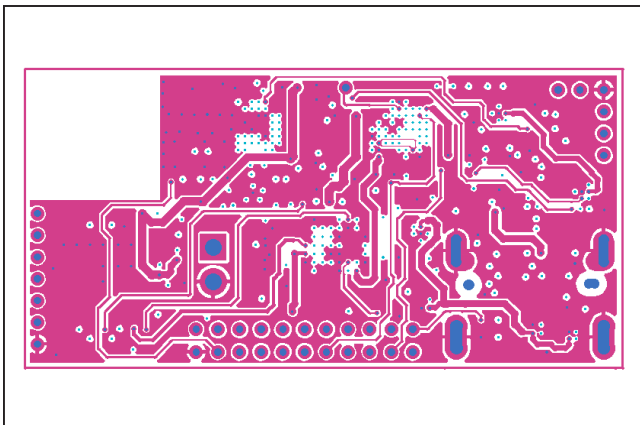

MAXSensorBLE_EVKIT—L04_SIGS

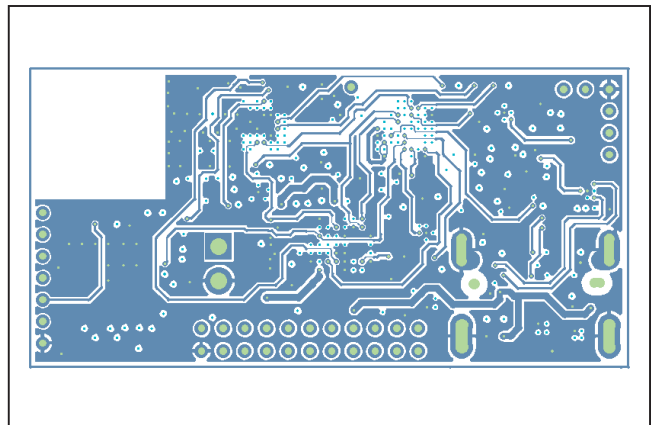

MAXSensorBLE_EVKIT—L05_SIGS

MAX86171 EV Kit PCB Layout Diagrams (continued)

MAXSensorBLE_EVKIT

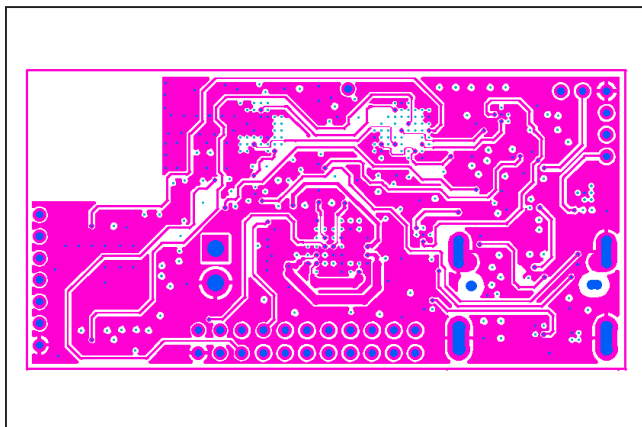

MAXSensorBLE_EVKIT—L06_SIGS

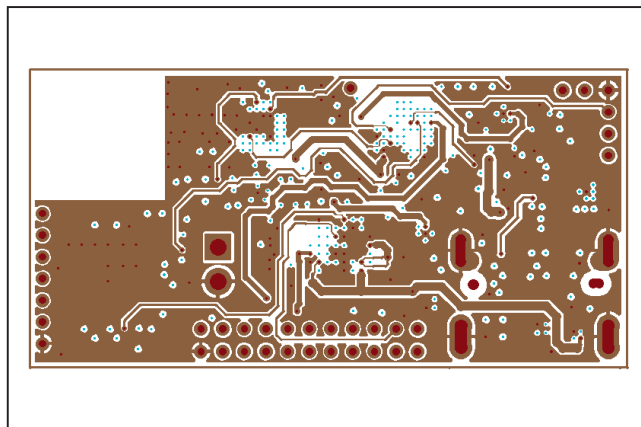

MAXSensorBLE_EVKIT—L07_SIGS

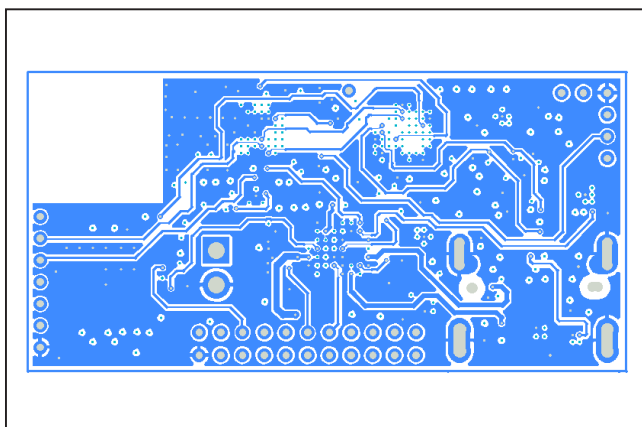

MAXSensorBLE_EVKIT—L08_SIGS

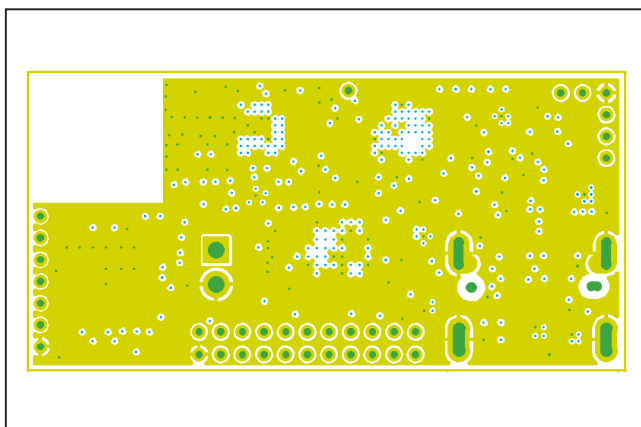

MAXSensorBLE_EVKIT—L09_GND

MAX86171 EV Kit PCB Layout Diagrams (continued)

MAXSensorBLE_EVKIT

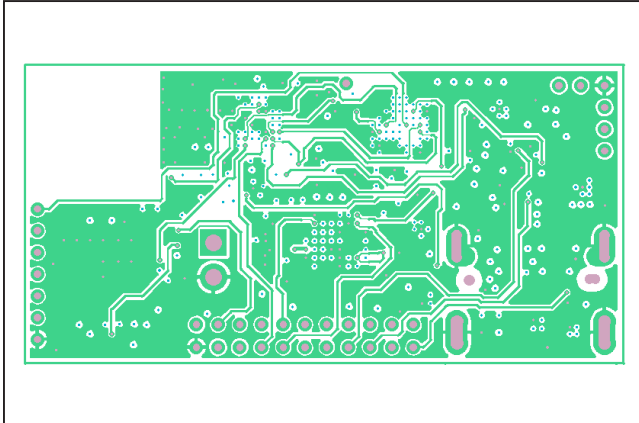

MAXSensorBLE_EVKIT—L10_SIGS

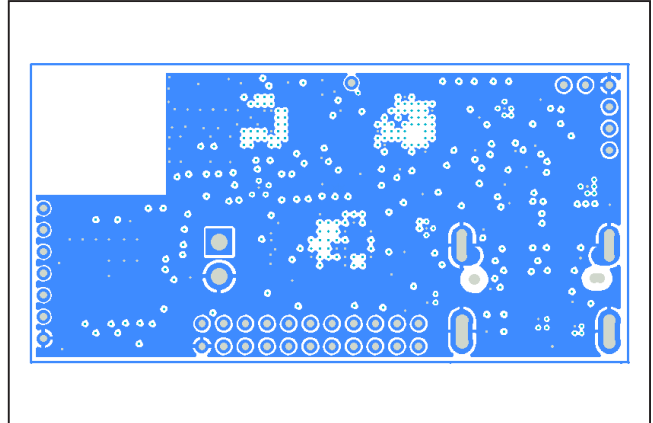

MAXSensorBLE_EVKIT—L11_GND

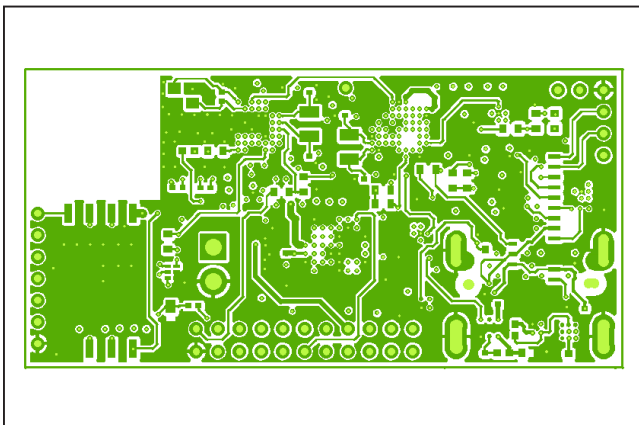

MAXSensorBLE_EVKIT—BOTTOM

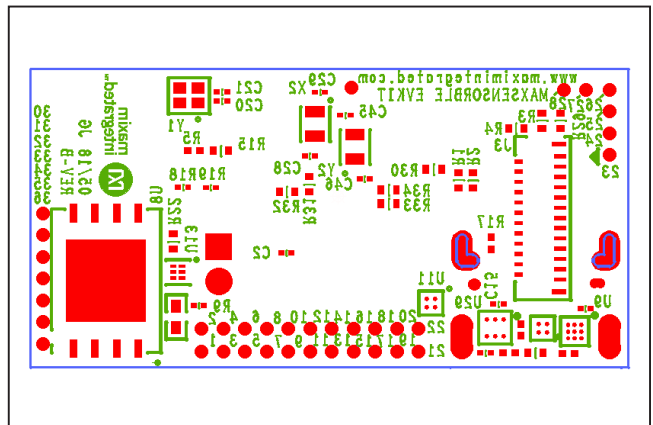

MAXSensorBLE_EVKIT—Bottom Silkscreen

MAX86171 EV Kit PCB Layout Diagrams (continued)

MAX86171_OSBEVKIT

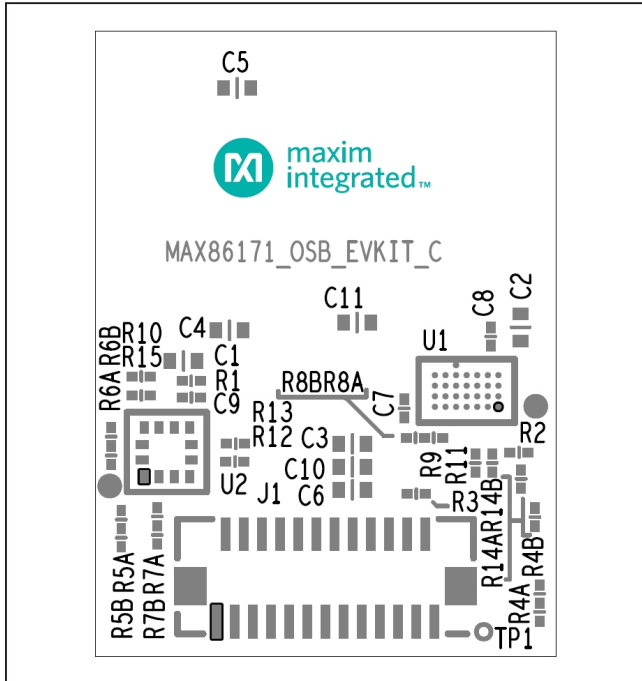

MAX86171OSBEK#—Top Silkscreen

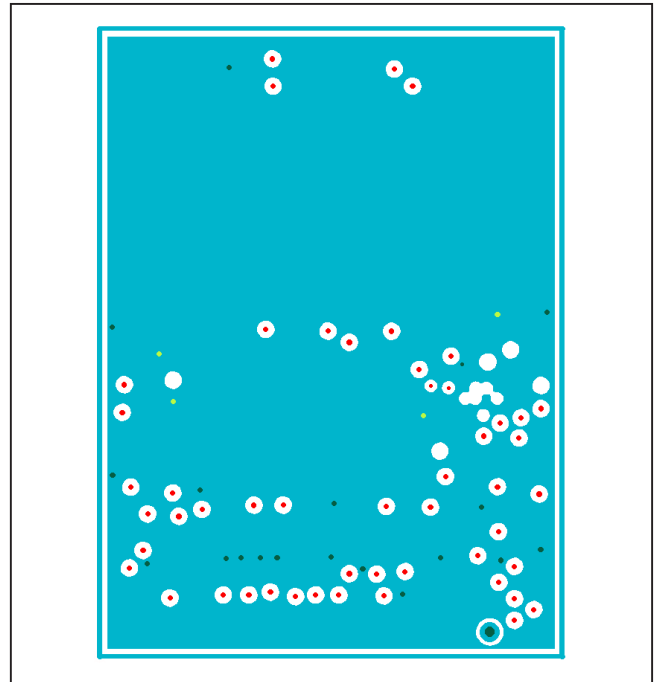

MAX86171OSBEK#—L02_GND

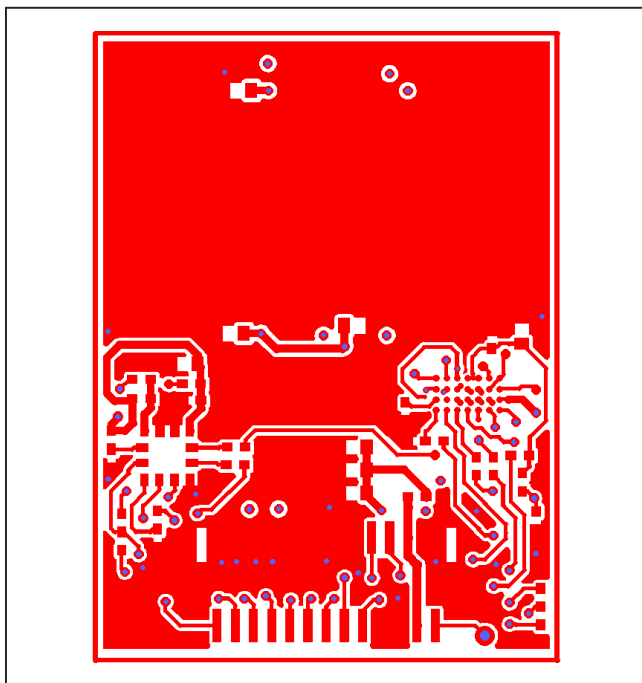

MAX86171OSBEK#—Top

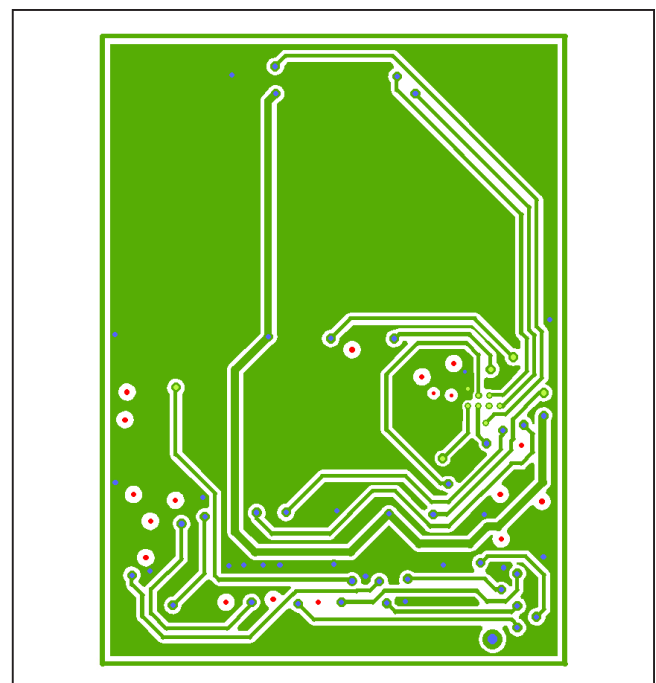

MAX86171OSBEK#—L03_SIG

MAX86171 EV Kit PCB Layout Diagrams (continued)

MAX86171_OSB_EVKIT

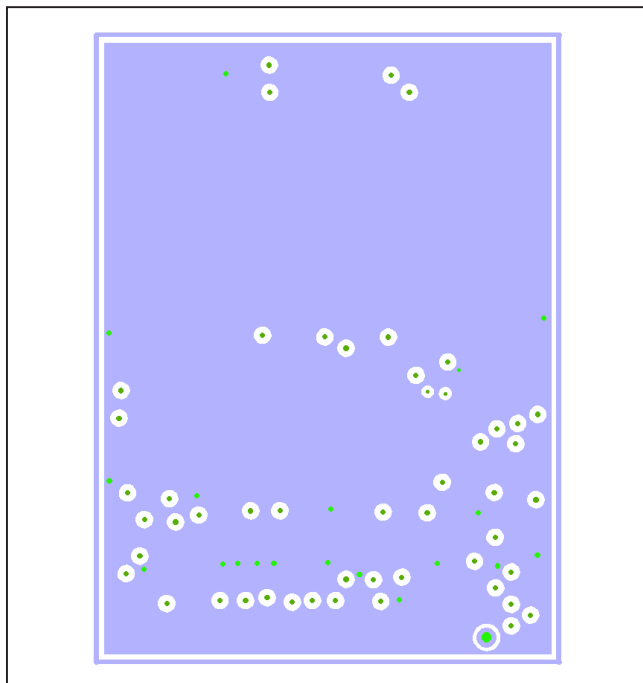

MAX86171OSBEK#—L04_GND

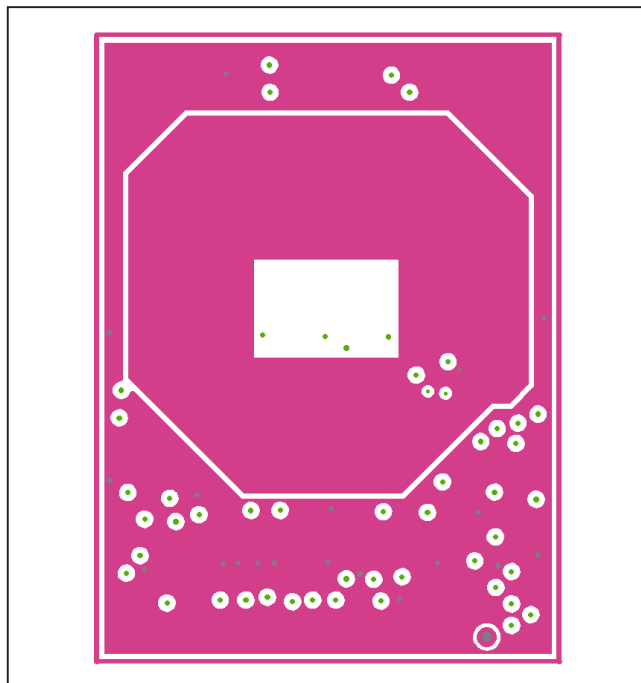

MAX86171OSBEK#—L05_PDGND

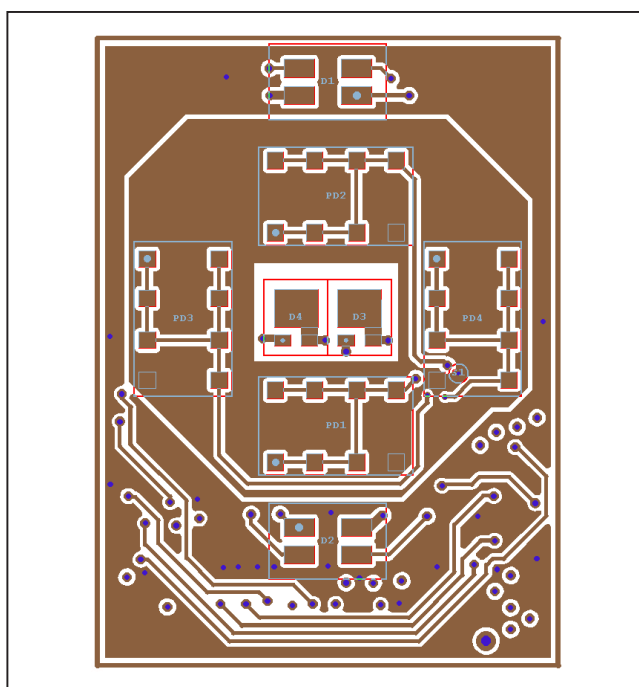

MAX86171OSBEK#—Bottom

Revision History

| REVISION NUMBER | REVISION DATE | DESCRIPTION | PAGES CHANGED |
|-----------------|---------------|---|---------------|
| 0 | 12/19 | Initial release | — |
| 1 | 1/20 | Updated the title to evaluate MAX86170A and MAX86170B | 1–31 |
| 2 | 2/20 | Updated the title to evaluate only MAX86171 and MAX86170B | 1–31 |
| 3 | 4/20 | Updated the <i>MAX86171OSBEK#—Top Silkscreen</i> | 29 |
| 4 | 5/20 | Updated the title to add MAX86170A | 1–31 |

For pricing, delivery, and ordering information, please visit Maxim Integrated's online storefront at <https://www.maximintegrated.com/en/storefront/storefront.html>.

Maxim Integrated cannot assume responsibility for use of any circuitry other than circuitry entirely embodied in a Maxim Integrated product. No circuit patent licenses are implied. Maxim Integrated reserves the right to change the circuitry and specifications without notice at any time.