



# MAX8631X Evaluation Kit

## General Description

The MAX8631X evaluation kit (EV kit) is a fully assembled and tested circuit for evaluating the MAX8631X white LED 1x/1.5x/2x charge pump with two LDOs. The MAX8631X EV kit drives 4 white LEDs for backlighting and uses 4 flash LED drivers to drive a flash LED module at a high current. The two 200mA LDOs are also available for evaluation. In addition to the LED driver circuit and LDOs, the EV kit includes one pulse-generator circuit and two momentary pushbutton switches that are used for testing the single-wire, serial-pulse-dimming and flash features of the MAX8631X. The MAX8631X EV kit can also evaluate the MAX8631Y. To evaluate the MAX8631Y, order a free sample along with this EV kit.

## Ordering Information

PART	TYPE
MAX8631XEVKIT	EV Kit

## Features

- ◆ MAX8631X Powers Up to 4 Main LEDs and 4 Flash LEDs
- ◆ EV Kit Powers 4 Main LEDs and a Flash LED Module
- ◆ 94% Maximum/85% Average Efficiency (PLED/PBATT) over Li+ Battery Discharge
- ◆ 0.2% Typical LED Current Matching
- ◆ Adaptive 1x/1.5x/2x Mode Switchover
- ◆ Single-Wire, Serial-Pulse Interface (3% to 100% Brightness)
- ◆ Thermal T<sub>A</sub> Derating Function
- ◆ Two Internal Low-Noise 200mA LDOs
- ◆ 2.7V to 5.5V Supply Voltage Range
- ◆ Soft-Start, Overvoltage, and Thermal-Shutdown Protection
- ◆ 4mm x 4mm 28-Pin Thin QFN IC Package
- ◆ Fully Assembled and Tested

## Component List

DESIGNATION	QTY	DESCRIPTION
C1, C5	2	10µF ±20%, 6.3V X5R ceramic capacitors (0805) TDK C2012X5R0J106M or Murata GRM219R60J106M
C3, C4, C6, C7	4	1µF ±20%, 6.3V X5R ceramic capacitors (0402) TDK C1005X5R0J105M or Murata GRM155R60J105K
C8	1	0.01µF ±10%, 25V X7R ceramic capacitor (0402) TDK C1005X7R1E103K or Murata GRM155R71E103K
C9	1	1000pF ±10%, 50V X7R ceramic capacitor (0402) TDK C1005X7R1H102K or Murata GRM155R71H102K
C10	1	2.2µF ±10%, 6.3V X5R ceramic capacitor (0603) TDK C1608X5R0J225K or Murata GRM185R60J225K
D1–D4	4	White LEDs Nichia NSCW215T

DESIGNATION	QTY	DESCRIPTION
D5	1	LED Nichia NBCW011T
D6	1	SOD-523 diode, CMOS-3 Central Semiconductor
JU1, JU2, JU3, JU5	4	3-pin headers
JU4	1	2-pin headers
JU6–JU9	0	Not installed, PC board shorts
R1	1	6.81kΩ ±1% resistor (0402)
R2	1	5.11kΩ ±1% resistor (0402)
R3	1	22.1kΩ ±1% resistor (0402)
R4	1	100kΩ ±1% resistor (0402)
R5	1	2.2kΩ ±1% resistor (0402)
S1, S2	2	Momentary pushbutton switches Panasonic EVQ-PHP03T
U1	1	White LED charge pump (28 TQFN-EP*) Maxim MAX8631XETI
U2	1	6-channel PMIC (40 TQFN) Maxim MAX6816EUS-T
—	5	Shunt, two positions
—	1	PCB: MAX8631X Evaluation Kit

\*EP = Exposed pad.

Evaluates: MAX8631X/MAX8631Y



# MAX8631X Evaluation Kit

## Component Suppliers

SUPPLIER	PHONE	WEBSITE
Central Semiconductor Corp.	631-435-1110	www.centralsemi.com
Murata Electronics North America, Inc.	770-436-1300	www.murata-northamerica.com
Nichia Corp.	248-352-6575	www.nichia.com
Panasonic Corp.	800-344-2112	www.panasonic.com
TDK Corp.	847-803-6100	www.component.tdk.com

**Note:** Indicate that you are using the MAX8631X or MAX8631Y when contacting these component suppliers.

### Quick Start

#### Recommended Equipment

Before beginning, the following equipment is needed:

- A 2.7V to 5.5V power supply or a lithium battery capable of delivering 1.5A
- Two digital multimeters (DMMs)
- Two 200mA loads
- Ammeter (optional)

#### Procedure

The MAX8631X EV kit is fully assembled and tested. Follow the steps below to verify board operation:

- 1) Preset the power supply to between 2.7V and 5.5V.
- 2) Turn off the power supply. **Caution: Do not turn on the power supply until all connections are completed.**
- 3) Verify that the shunt on JU3 is connected to OFF (pins 2-3). Verify that the shunt on JU5 is connected to ON (pins 1-2). Verify that there is a shunt on JU4. Verify that there is no shunt on JU1 and JU2.
- 4) Connect the positive power-supply terminal to the pad on the EV kit labeled IN.
- 5) Connect the power-supply ground terminal to the pad on the EV kit labeled GND.
- 6) Connect a DMM across the LDO1 pad on the EV kit and the GND pad on the EV kit.
- 7) Connect a DMM across the LDO2 pad on the EV kit and the GND pad on the EV kit.
- 8) Turn on the power supply and verify that the main LEDs are lit.
- 9) Push S2 for only a short duration to verify that the flash LED module lights. Holding S2 down for long durations may damage the flash LED module. See the *Detailed Description* section for testing the dimming and shutdown features.

- 10) Remove the shunt from the OFF position (pins 2-3) of JU3 and place on the ON position (pins 1-2) of JU3.

- 11) Verify the voltage at LDO1 is near 2.6V.
- 12) Connect a 200mA load between LDO1 and GND.
- 13) Verify the voltage at LDO1 is near 2.6V.
- 14) Verify the voltage at LDO2 is near 1.8V.
- 15) Connect a 200mA load between LDO2 and GND.
- 16) Verify the voltage at LDO2 is near 1.8V.

### Detailed Description

#### LED Dimming of the Main Display

To test the dimming feature, press the button labeled DIM MAIN. Each button depression dims the main LEDs by 3.125%. Due to the logarithmic response of the human eye, it takes many depressions of the button to visually notice dimming. The 31st pulse reduces the current to 3.125%. The 32nd pulse sets the LED current back to 100%. Refer to the MAX8631X data sheet for more information on the dimming feature.

#### Single-Wire Pulse Dimming for Main or Flash Using External Pulse Generators

To use an external pulse generator in place of the pulse generator included with the EV kit or to reduce the number of control traces, the MAX8631X supports serial-pulse dimming. Connect the output of the external pulse generator to ENM1 or ENM2 to enable single-wire pulse dimming of the main LEDs. Use ENF for single-wire pulse dimming of the flash LED module. The ground of the external pulse generator should be connected to the EV kit pad labeled GND. Ensure that there is a shunt on JU5 connected to ON (pins 1-2). When ENM1 and ENM2 (or ENF) go high simultaneously, the main (or flash) LEDs are enabled at full brightness. Each subsequent low-going pulse (500ns to 250µs pulse width) reduces the LED current by 3.125% (1/32), so after one pulse the LED current is 96.9% (or 31/32). The 31st pulse reduces the current to 3.125%.

# MAX8631X Evaluation Kit

Evaluates: MAX8631X/MAX8631Y

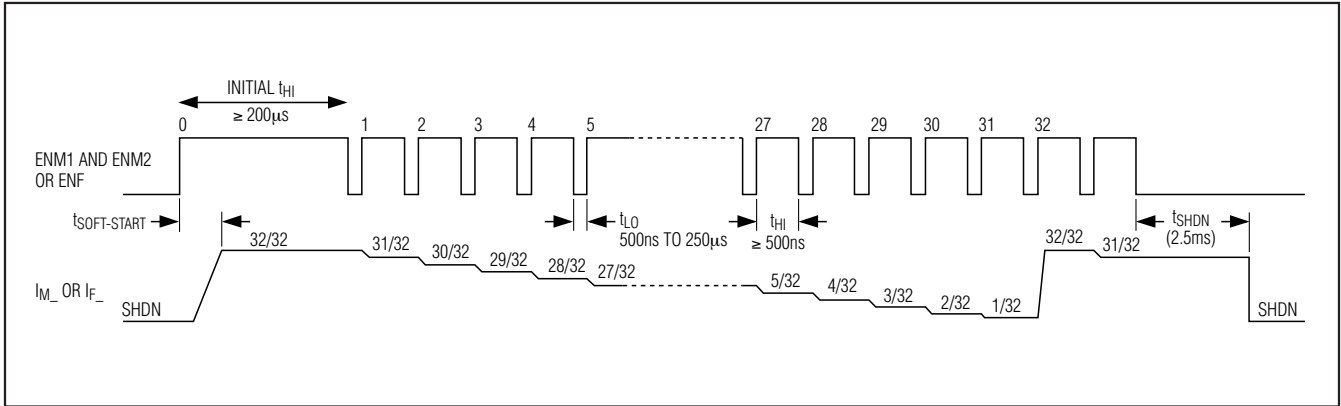

Figure 1. ENM\_ and ENF Timing Diagram

The 32nd pulse sets the LED current back to 100%. Figure 1 shows a timing diagram for single-wire pulse dimming. Because soft-start is longer than the initial  $t_{HI}$ , apply dimming pulses quickly upon startup (after initial  $t_{HI}$ ) to avoid LED current transitioning through full brightness. Note there is a 2.2k $\Omega$  pullup resistor from ENM2 to IN on the EV kit and a 100k $\Omega$  pulldown resistor connected to ENF.

### Flash LED

To test the flash feature, press the button labeled FLASH. This button should only be held for short durations to prevent overheating of the flash LED module. Jumper JU4 is provided to allow for lower current testing of the flash LED module, typically called movie mode in cell phone applications. The shunt on jumper JU4 can be removed for testing the flash LED module at 75mA total (18.7mA per  $F_{-}$ ). To test without the push-button switch, use ENF to control the flash LED operation; refer to the MAX8631X/MAX8631Y IC data sheet for more information. Note that there is a 100k $\Omega$  pulldown resistor connected to ENF.

### Adjusting the MAIN 100% Brightness Level

The full-brightness LED current for the main display is adjustable by changing the resistor R1. Calculate the value of R1 with the following equation, where  $I_{M_{-}}$  is the sink current through each  $M_{-}$  current regulator with the dimming set to 100%:

$$R1 = \frac{0.6V \times 230}{I_{M_{-}}}$$

### Adjusting the Flash 100% Brightness Level

The full-brightness LED current for the flash is adjustable by changing resistors R2 and R3. Calculate the value of  $R_T$  with the following equation, where  $I_{F\_FLASH}$  is the sink current through each  $F_{-}$  current regulator with the dimming set to 100%:

$$R_T = \frac{0.6V \times 690}{I_{F\_FLASH}}$$

where  $R_T$  is the parallel combination of R2 and R3. R3 is the low-current-set resistor, which must be calculated first using the equation below.  $I_{F\_MOVIE}$  is the sink current through each  $F_{-}$  current regulator in movie mode:

$$R_3 = \frac{0.6V \times 690}{I_{F\_MOVIE}}$$

Once R3 is determined, then R2 can be calculated using the following equation:

$$R_2 = \frac{R_3 \times R_T}{R_3 - R_T}$$

# MAX8631X Evaluation Kit

## Shutdown Control

One jumper is included on the EV kit for shutting down the main LEDs. To turn off the main LEDs, place the shunt on the OFF side of jumper JU5 (pins 2-3). Note that with JU5 shunted off, power is disconnected from the pulse-generator circuit. The MAX8631X is in low-power shutdown mode when both JU5 and JU3 are shunted off since flash is nominally off (see the *Low-Dropout (LDO) Regulator* section).

## Changing the Number of LEDs

The EV kit comes with four LEDs for the main display and a flash LED module. To use fewer LEDs, locate the small pad (labeled TP\_) next to the LED to be removed and connect it to the pad on the EV kit labeled TP9.

## Connecting External LEDs

To connect external LEDs to the MAX8631X EV kit, cut the trace shorting JU7. Connect the anodes of all the external LEDs to the small pad labeled TP9. Connect the cathodes to the small pads next to D1–D8 (TP1–TP4 for the main LEDs, TP5–TP8 for the flash LEDs). Connect any unused pads (TP1–TP8) to the pad labeled TP9. Also, cut JU8 and JU9 as needed to support individual flash LEDs.

## Low-Dropout (LDO) Regulator

### LDO Shutdown

One jumper is included on the EV kit for shutting down both LDOs. To turn off the LDOs, place the shunt on the OFF side (pins 2-3) of jumper JU3. To turn on the LDOs, place the shunt on the ON side (pins 1-2) of jumper JU3.

**Table 1. P1 and P2, LDO Output Voltage Selection for MAX8631X**

P1	P2	LDO1 (V)	LDO2 (V)
GND	GND	2.5	1.8
GND	OPEN	2.8	1.8
GND	IN	3.0	1.8
IN	GND	2.8	1.5
IN	OPEN	3.0	1.5
IN	IN	3.3	1.8
OPEN	GND	2.6	1.5
OPEN	OPEN	2.6	1.8
OPEN	IN	3.3	1.5

### LDO Output Voltage Selection (P1 and P2)

As shown in Table 1, the LDO output voltages, LDO1 and LDO2, are pin programmable by the logic states of P1 (jumper JU1) and P2 (jumper JU2). P1 and P2 are tri-level inputs: IN (pins 1-2), open, and GND (pins 2-3). The input voltage,  $V_{IN}$ , must be greater than the selected LDO1 and LDO2 output voltages to prevent dropout. The logic states of P1 and P2 can be programmed only when ENLDO is low. Once the LDO\_ voltages are programmed, their values do not change by changing P1 or P2 when ENLDO is high.

When evaluating the MAX8631Y, refer to the MAX8631X/MAX8631Y IC data sheet for the LDO output-voltage selection.

### Evaluating the MAX8631Y

For evaluating the MAX8631Y, carefully remove the MAX8631X (U1) and install the MAX8631Y. All other components can remain the same.

# MAX8631X Evaluation Kit

Evaluates: MAX8631X/MAX8631Y

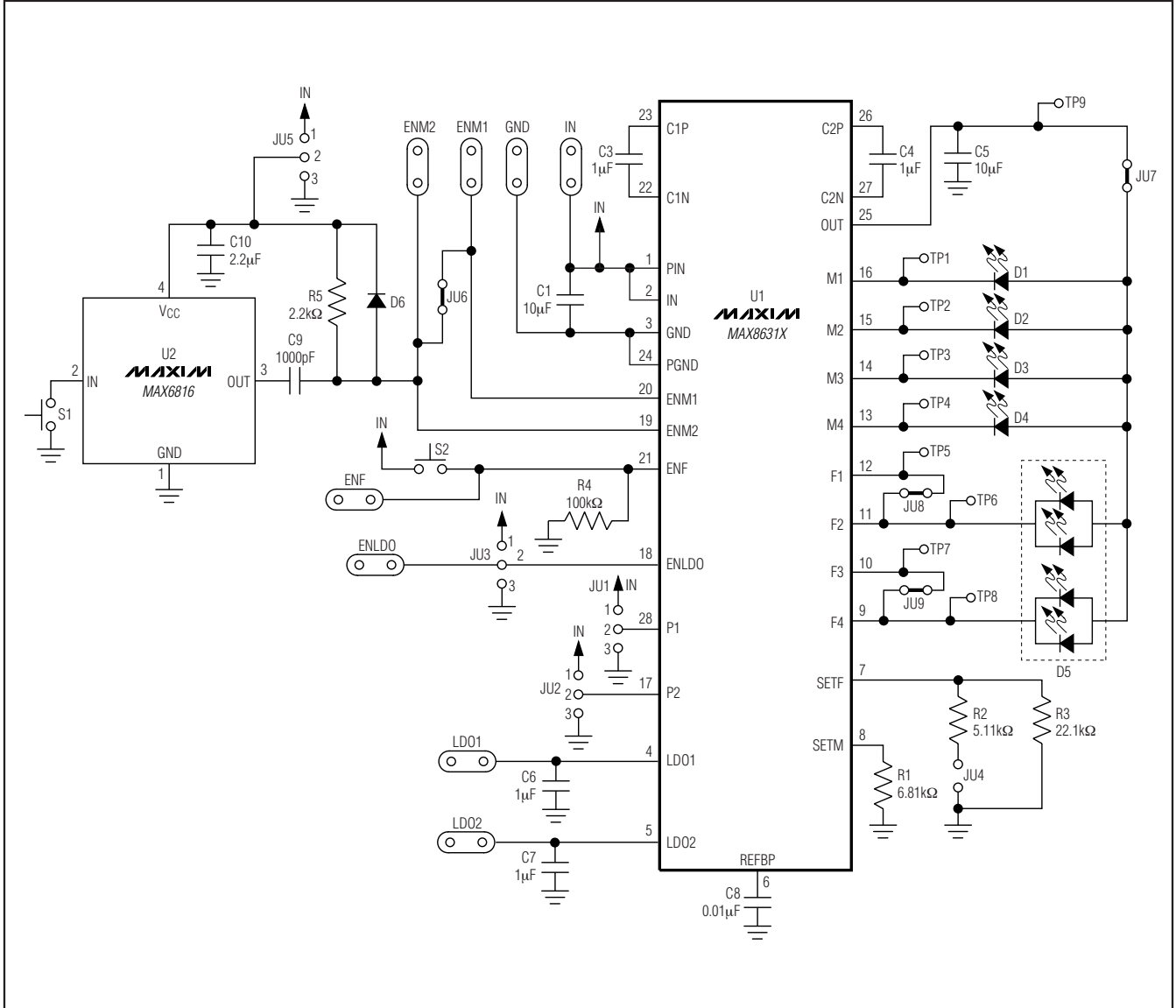

Figure 2. MAX8631X EV Kit Schematic



# MAX8631X Evaluation Kit

Evaluates: MAX8631X

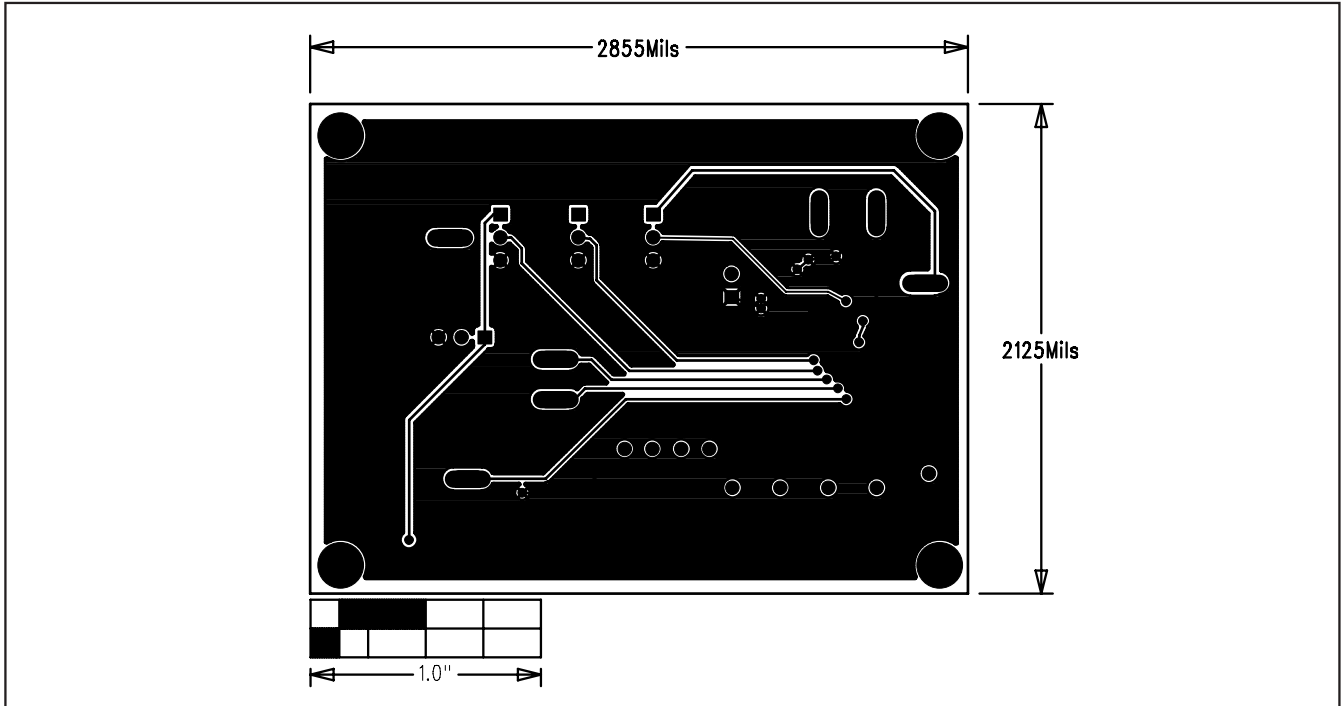

Figure 5. MAX8631X EV Kit PCB Layout—Solder Side

# MAX8631X Evaluation Kit

## Revision History

REVISION NUMBER	REVISION DATE	DESCRIPTION	PAGES CHANGED
0	9/05	Initial release	—
1	5/08	Removed PWM dimming control feature.	3

Maxim cannot assume responsibility for use of any circuitry other than circuitry entirely embodied in a Maxim product. No circuit patent licenses are implied. Maxim reserves the right to change the circuitry and specifications without notice at any time.

8 **Maxim Integrated Products, 120 San Gabriel Drive, Sunnyvale, CA 94086 408-737-7600**