



MAX8646 Evaluation Kit

General Description

The MAX8646 evaluation kit (EV kit) is a fully assembled and tested PCB that demonstrates the capabilities of the MAX8646 integrated 6A step-down regulator. The EV kit generates a +1.8V output voltage at load currents up to 6A from a 2.35V to 3.6V input voltage range. The MAX8646 switches at 1MHz and up to 95% efficiency with the supplied components.

Ordering Information

PART	TYPE
MAX8646EVKIT+	EV Kit

+Denotes lead-free and RoHS compliant.

Features

- ◆ Internal 23mΩ On-Resistance MOSFETs
- ◆ 6A Output PWM Step-Down Regulator
- ◆ ±1% Output Accuracy over Load, Line, and Temperature
- ◆ Operates from 2.35V to 3.6V Input Supply
- ◆ Adjustable Output from 0.6V to (0.9 x V_{IN})
- ◆ 500kHz to 2MHz Adjustable Frequency
- ◆ Allows All-Ceramic Capacitor Design
- ◆ Programmable Soft-Start Time
- ◆ 24-Pin, 4mm x 4mm Thin QFN Package
- ◆ REFIN for DDR Termination and Tracking Applications
- ◆ Surface-Mount Components
- ◆ Assembled and Tested

Evaluates: MAX8646

Component List

DESIGNATION	QTY	DESCRIPTION
C1, C2A, C2B	3	22μF ±10%, 6.3V X5R ceramic capacitors (0805) TDK C2012X5R0J226K
C3, C9	2	0.1μF ±10%, 25V X7R ceramic capacitors (0603) TDK C1608X7R1E104K
C4, C6	2	0.01μF ±10%, 50V X7R ceramic capacitors (0603) TDK C1608X7R1H103K
C5	1	1μF ±10%, 16V X5R ceramic capacitor (0603) TDK C1608X5R1C105K
C7, C13, C14	0	Not installed, ceramic capacitors (0603)
C8	1	1000pF, 50V X7R ceramic capacitor (0603) TDK C1608X7R1H102K
C10	1	680pF ±10%, 50V X7R ceramic capacitor (0603) TDK C1608X7R1H681K
C11	1	1500pF ±10%, 50V X7R ceramic capacitor (0603) TDK C1608X7R1H152K
C12	1	33pF ±5pF, 50V C0G ceramic capacitor (0603) TDK C1608C0G1H330CT

DESIGNATION	QTY	DESCRIPTION
C15	1	1000pF ±10%, 50V X7R ceramic capacitor (0603) TDK C1608X7R1H102K
JU1, JU2	2	2-pin headers
JU3, JU4	2	3-pin headers
L1	1	0.47μH, 7.6mΩ, 9.6A inductor (7.7mm x 7mm x 2mm) TOKO FDV0620-R47
R1	1	10Ω ±5% resistor (0603) lead free
R2	1	10kΩ ±5% resistor (0603) lead free
R3	1	1kΩ ±5% resistor (0603) lead free
R4	1	3.57kΩ ±1% resistor (0603) lead free
R5	1	20kΩ ±5% resistor (0603) lead free
R6	1	432Ω ±1% resistor (0603) lead free
R7	1	49.9kΩ ±1% resistor (0603) lead free
R8	0	Not installed, resistor (0603). Must be 8.06kΩ ±1% resistor (0603) when populated for adjustable output voltage programming.
R9	0	Not installed, resistor (0603) for adjustable output voltage programming

MAX8646 Evaluation Kit

Component List (continued)

DESIGNATION	QTY	DESCRIPTION
R10	1	2.2Ω ±5% resistor (0603) lead free
U1	1	Step-down regulator (24 TQFN) Maxim MAX8646ETG+
—	5	Shunts
—	1	PCB: MAX8646 Evaluation Kit+

Quick Start

Recommended Equipment

Before beginning, the following equipment is needed:

- 2V to 4V at +6A variable DC power supply or battery
- Digital multimeter (DMM)
- Up to 6A load
- Ammeter (optional)

Procedure

The MAX8646 EV kit is fully assembled and tested. Follow the steps below to verify board operation:

- 1) Preset the DC power supply to 3.3V. Turn off the power supply. **Caution: Do not turn on the power supply until all connections are made.**
- 2) Remove the shunt from JU1.
- 3) Verify that no two pins are shunted together on jumper JU3.
- 4) Verify that there is a shunt on pins 1-2 of jumper JU4.
- 5) Connect the positive lead of the power supply to the IN pad and connect the negative lead of the power supply to the GND pad on the EV kit.
- 6) Connect the positive lead of the DMM to the OUT pad and connect the negative lead of the DMM to the GND pad on the EV kit.
- 7) Turn on the power supply.
- 8) Verify that the voltage at OUT is 1.8V.
- 9) Connect the load between OUT and GND.
- 10) Verify that the voltage at OUT is 1.8V.

Component Suppliers

SUPPLIER	PHONE	WEBSITE
TDK Corp.	847-803-6100	www.component.tdk.com
TOKO America, Inc.	847-297-0070	www.tokoam.com

Note: Indicate that you are using the MAX8646 when contacting these component suppliers.

Detailed Description of Hardware

Evaluating Other Output Voltages

The MAX8646 EV kit comes preset to a 2.5V output voltage. As shown in Table 1, the output voltage is pin-programmable by the logic states of CTL1 and CTL2, jumpers JU3 and JU4, respectively. CTL1 and CTL2 are three-level inputs: V_{DD}, unconnected, and GND. The logic states of CTL1 and CTL2 should be programmed only before power-up. To avoid damage to the IC, CTL1 and CTL2 should not be changed once soft-start is complete. If the output voltage needs to be reprogrammed, cycle power or EN and reprogram during or before soft-start.

Table 1. CTL1 and CTL2 Output Voltage Selection

CTL1/JU3	CTL2/JU4	V _{OUT} (V)
2-3	2-3	0.6 or external divider
1-2	1-2	0.7
2-3	Unconnected	0.8
2-3	1-2	1.0
Unconnected	2-3	1.2
Unconnected	Unconnected	1.5
Unconnected	1-2	1.8
1-2	2-3	2.0
1-2	Unconnected	2.5

When the output voltage of the MAX8646 is programmed to a preset voltage, R_i is internal to the IC and R₉ is not installed (Figure 1b).

MAX8646 Evaluation Kit

Evaluates: MAX8646

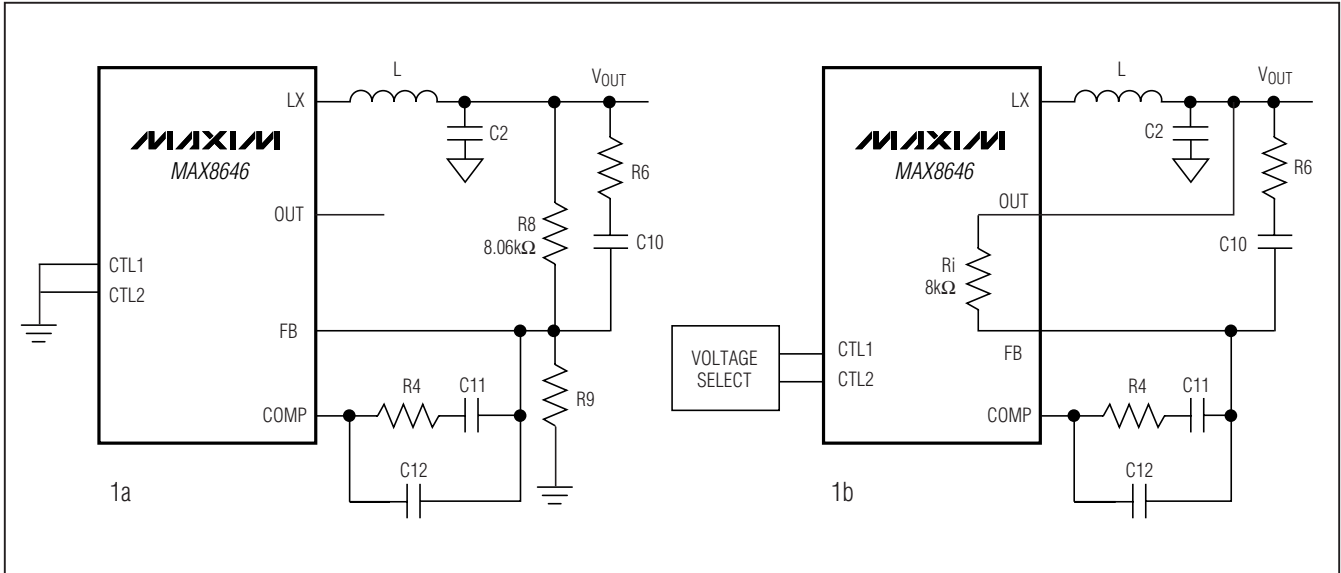

Figure 1. Preset and Adjustable Output Configuration

When externally programming the MAX8646 (Figure 1a), install an 8.06kΩ resistor at R8. The output voltage is then determined by:

$$R9 = \frac{4836}{V_{OUT} - 0.6}$$

For an output voltage of 0.6V, install an 8.06kΩ resistor at R8 and do not install R9. Refer to the MAX8646 IC data sheet for information on selecting output inductor, capacitor, and compensation components to optimize the circuit for different output voltages.

Evaluating Other Switching Frequencies (FREQ)

The MAX8646 EV kit comes preset with a 1MHz switching frequency. Replace R7 to change the switching frequency. R7 is calculated as:

$$R7 = 52.63 \times \left(\frac{1}{f_s} - 0.05 \right) \text{k}\Omega$$

where the switching frequency is in megahertz and must be between 500kHz and 2MHz. Refer to the MAX8646 IC data sheet for information on selecting output inductor, capacitor, and compensation components to optimize the circuit for different switching frequencies.

Using the REFIN Input

The MAX8646 features an external reference input (REFIN). The IC regulates FB to the voltage applied to REFIN. The internal soft-start is not available when using an external reference. A method of soft-start when using an external reference is shown by the use of R3 and C7 in Figure 2. To use the REFIN input of the EV kit, remove the shunt on jumper JU2. Connect an external reference to the REFIN pad on the EV kit. If the external reference produces step-voltage changes, install C7. Refer to the MAX8646 IC data sheet for more details.

Power Good (PWRGD)

PWRGD is an open-drain output that goes high impedance when V_{FB} is above 0.54V. PWRGD pulls low when V_{FB} is below 0.54V for at least 48 clock cycles. PWRGD is low during shutdown. PWRGD is pulled up to V_{DD} through R5.

Jumper JU1 Function (Shutdown Mode)

The MAX8646 features a shutdown mode to minimize the IC quiescent current. To shut down the IC, place a shunt between pins 1-2 of JU1. For normal operation, remove the shunt from JU1.

Soft-Starting into a Prebiased Output

When the PREBIAS pin is left unconnected, the MAX8646 is capable of soft-starting up into a prebiased output without discharging the output capacitor. This type of operation is also termed monotonic startup.

MAX8646 Evaluation Kit

However, in order to avoid output-voltage glitches during soft-start, it should be ensured that the inductor current is in continuous conduction mode during the end of the soft-start period. This is done by satisfying the following equation:

$$C_O \times \frac{V_O}{t_{SS}} \geq \frac{I_{P-P}}{2}$$

where C_O is the output capacitor, V_O is the output voltage, t_{SS} is the soft-start time set by the soft-start

capacitor C_{SS} , and I_{P-P} is the peak-to-peak inductor ripple current (as defined in the *Output Capacitor Selection* section in the MAX8646 IC data sheet). Connecting the PREBIAS pin to GND disables the pre-bias soft-start feature and causes the MAX8646 to discharge any voltage present on the output capacitors and then commence its soft-start.

To disconnect the PREBIAS pin from GND, cut the trace in front of JU1 on the top side of the MAX8646 EV kit PCB.

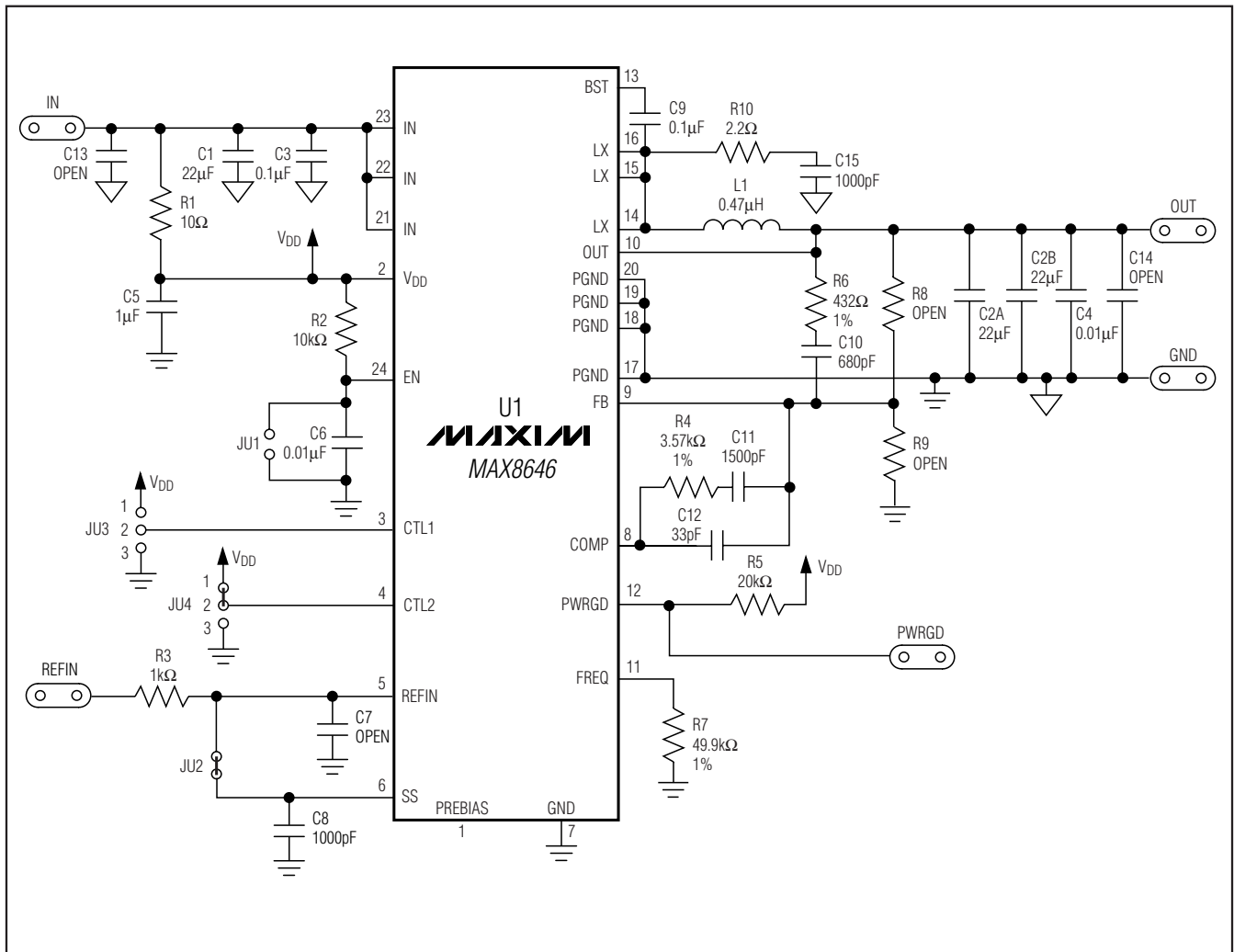

Figure 2. MAX8646 EV Kit Schematic

MAX8646 Evaluation Kit

Evaluates: MAX8646

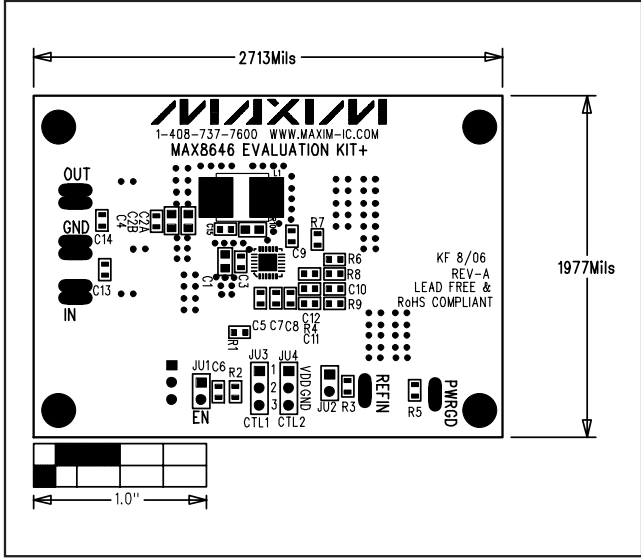

Figure 3. MAX8646 EV Kit Component Placement Guide—Top Silkscreen

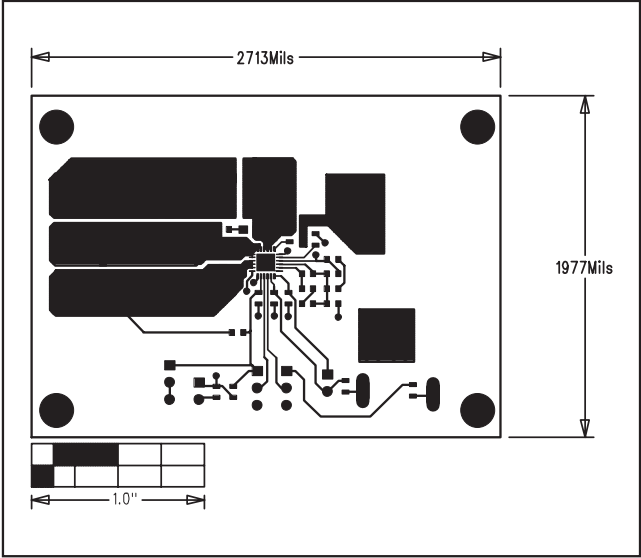

Figure 4. MAX8646 EV Kit PCB Layout—Component Side

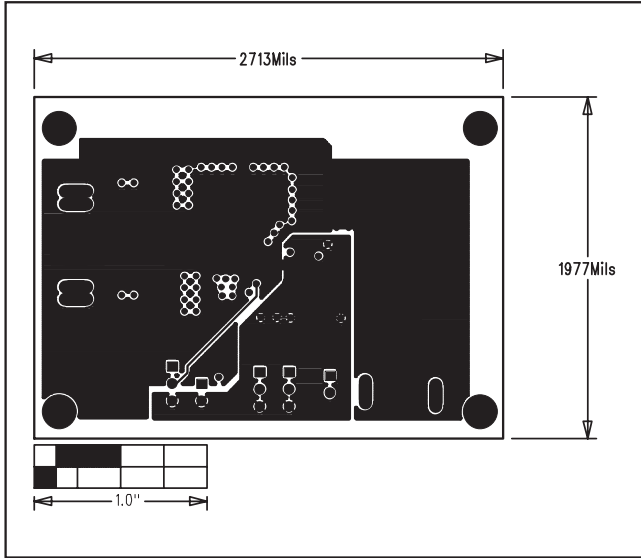

Figure 5. MAX8646 EV Kit PCB Layout—Layer 2

MAX8646 Evaluation Kit

Evaluates: MAX8646

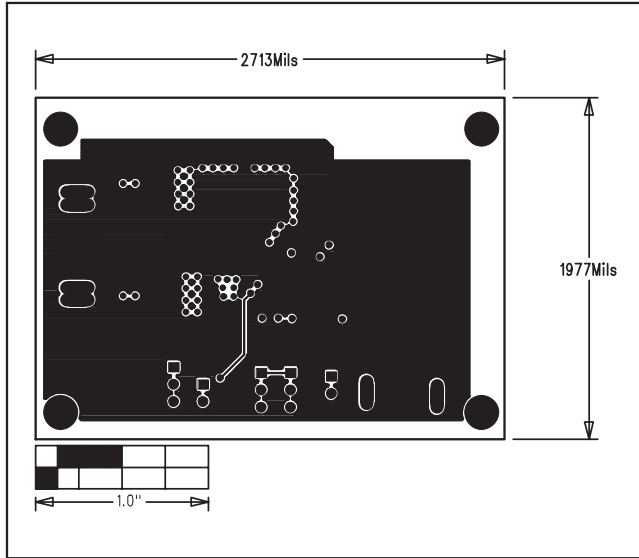

Figure 6. MAX8646 EV Kit PCB Layout—Layer 3

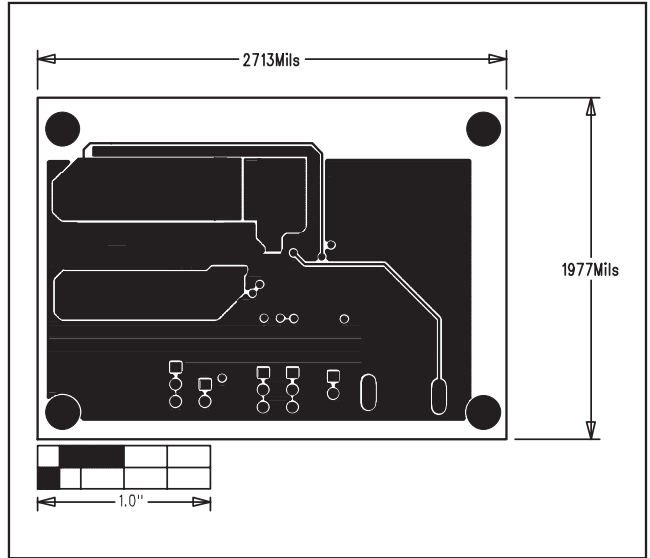

Figure 7. MAX8646 EV Kit PCB Layout—Solder Side

MAX8646 Evaluation Kit

Revision History

REVISION NUMBER	REVISION DATE	DESCRIPTION	PAGES CHANGED
0	10/06	Initial release	—
1	6/08	Changed value of soft-start capacitor C8 to incorporate prebias feature.	1, 3, 4

Evaluates: MAX8646

Maxim cannot assume responsibility for use of any circuitry other than circuitry entirely embodied in a Maxim product. No circuit patent licenses are implied. Maxim reserves the right to change the circuitry and specifications without notice at any time.

Maxim Integrated Products, 120 San Gabriel Drive, Sunnyvale, CA 94086 408-737-7600 _____ 7