



MAX8858 Evaluation Kit

Evaluates: MAX8858

General Description

The MAX8858 evaluation kit (EV kit) is a fully assembled and tested PCB for evaluating the MAX8858 power-management IC (PMIC). The MAX8858 PMIC provides a compact and complete power-supply solution for digital still cameras (DSCs) and digital video cameras (DVCs). The MAX8858 improves performance, component count, and board space utilization compared to currently available solutions for 2AA cell and dual-battery designs. On-chip power MOSFETs provide up to 95% efficiency for critical power supplies. The CCD inverter operates directly from two AA/NiMH batteries without the use of any additional external components.

Ordering Information

PART	TYPE
MAX8858EVKIT+	EV Kit

+Denotes lead(Pb)-free and RoHS compliant.

Features

- ◆ 95% Efficient Synchronous-Rectified DC-DC Converters
- ◆ 90% Efficient Boost-Buck Operation
- ◆ Up to 85% Efficient, High-Voltage DC-DC Converters
- ◆ Inverter Operates Directly from Two AA Batteries
- ◆ Active Discharge for CCD Inverter Supply
- ◆ Preset Power-Up Sequencing for MAIN, SDZ, and SD Converters
- ◆ Internal Compensation on All Channels
- ◆ True Shutdown™ on All Step-Up Converters
- ◆ Overload Protection
- ◆ Startup into Short Protection
- ◆ Soft-Start for Controlled Startup Current
- ◆ 100% Duty Cycle on Step-Down Converters
- ◆ 2MHz ±5% Switching Frequency
- ◆ 0.1µA Shutdown Supply Current
- ◆ All Internal Power MOSFETs
- ◆ Lead(Pb)-Free and RoHS Compliant
- ◆ Fully Assembled and Tested

Component List

DESIGNATION	QTY	DESCRIPTION
C1-C4, C6, C7	6	22µF ±10%, 6.3V X5R ceramic capacitors (1206) AVX 12066D226K KEMET C1206C226K9 Taiyo Yuden JMK316BJ226KL or equivalent
C5, C8, C9, C10, C12, C13	6	10µF ±10%, 6.3V X5R ceramic capacitors (0805) Murata GRM21BR60J106KE Taiyo Yuden JMK212BJ106KG-T TDK C2012X5R0J106K or equivalent

DESIGNATION	QTY	DESCRIPTION
C11, C14, C16	3	1µF ±10%, 6.3V X5R ceramic capacitors (0402) Murata GRM155R60J105K or equivalent
C15	1	2.2µF ±10%, 25V X5R ceramic capacitor (0805) Taiyo Yuden TMK212BJ225K or equivalent
C17	1	4.7µF ±10%, 16V X5R ceramic capacitor (0805) TDK C2012X5R1C475K Taiyo Yuden EMK212BJ475KG-T or equivalent

True Shutdown is a trademark of Maxim Integrated Products, Inc.



Maxim Integrated Products 1

For pricing, delivery, and ordering information, please contact Maxim Direct at 1-888-629-4642, or visit Maxim's website at www.maxim-ic.com.

MAX8858 Evaluation Kit

Component List (continued)

DESIGNATION	QTY	DESCRIPTION
C18	1	0.22 μ F \pm 10%, 16V X5R ceramic capacitor (0402) TDK C1005X5R1C224K or equivalent
C19	1	100pF \pm 10%, 50V C0G ceramic capacitor (0402) Taiyo Yuden UMK105CG101KV
D1, D2	2	40V, 500mA Schottky diodes (SOD123) Central Semi CMHSH5-4
JU1, JU4, JU6	0	Not installed, jumpers
JU2, JU3, JU5	0	Not installed, jumpers—short (PCB trace)
JU7–JU12	6	2-pin headers, 0.1in center Sullins PEC36SAAN Digi-Key S1012E-36-ND
L1	1	2 μ H, 2.47A power inductor (6.3mm x 6.2mm x 2mm) TOKO A918CY-2R0M (D62LCB series)
L2	1	1 μ H, 2.30A power inductor (4.1mm x 4.1mm x 1.2mm) TOKO A1101AS-1R0N (DEA4012CK series)

DESIGNATION	QTY	DESCRIPTION
L3, L4, L6	3	4.7 μ H, 0.95A power inductors (3.2mm x 3.0mm x 1.8mm) TOKO 1072AS-4R7M (DE2818C series)
L5	1	2.2 μ H, 1.35A power inductor (3.2mm x 3.0mm x 1.8mm) TOKO 1072AS-2R2M (DE2818C series)
R1	1	402k Ω \pm 1% resistor (0402)
R2, R6, R8, R10, R12	5	100k Ω \pm 1% resistors (0402)
R3	1	23.2k Ω \pm 1% resistor (0402)
R4	1	10.0k Ω \pm 1% resistor (0402)
R5	1	80.6k Ω \pm 1% resistor (0402)
R7	1	150k Ω \pm 1% resistor (0402)
R9	1	1.4M Ω \pm 5% resistor (0402)
R11	1	604k Ω \pm 1% resistor (0402)
R13	1	100 Ω \pm 1% resistor (0402)
U1	1	Power-management IC (32 thin QFN-EP*) Maxim MAX8858ETJ+
—	1	PCB: MAX8858 Evaluation Kit+

*EP = Exposed pad.

Component Suppliers

SUPPLIER	PHONE	WEBSITE
AVX Corporation	843-946-0238	www.avxcorp.com
Central Semiconductor Corp.	631-435-1110	www.centralsemi.com
Digi-Key Corp.	800-344-4539	www.digikey.com
KEMET Corp.	864-963-6300	www.kemet.com
Murata Electronics North America, Inc.	770-436-1300	www.murata-northamerica.com
Sullins Electronics Corp.	760-744-0125	www.sullinselectronics.com
Taiyo Yuden	800-348-2496	www.t-yuden.com
TDK Corp.	847-803-6100	www.component.tdk.com
TOKO America, Inc.	847-297-0070	www.tokoam.com

Note: Indicate that you are using the MAX8858 when contacting these component suppliers.

MAX8858 Evaluation Kit

Table 1. Jumper Settings (JU1–JU12)

JUMPER	INPUT/OUTPUT	SHUNT ON	SHUNT OFF
JU1	PVSD source	VSU connected	VSU disconnected*
JU2		VBATT connected*	VBATT disconnected
JU3	PVZ source	VSU connected*	VSU disconnected
JU4		VBATT connected	VBATT disconnected*
JU5	PVINV source	VBATT connected*	VBATT disconnected
JU6		VSU connected	VSU disconnected*
JU7	SD enable	Enabled*	Disabled
JU8	SDZ enable	Enabled*	Disabled
JU9	CCDINV enable	Enabled*	Disabled
JU10	CCDBST enable	Enabled*	Disabled
JU11	SU enable	Enabled*	Disabled
JU12	MAIN enable	Enabled*	Disabled

*Default position.

Quick Start

Recommended Equipment

- Variable 0.9V to 5.5V power supply or battery (2-cell alkaline or 2-cell NiMH batteries) capable of delivering 3A
- Voltmeter
- Loads (resistors or electronic loads)

Procedure

The MAX8858 EV kit is a fully assembled and tested surface-mount board. Follow the steps below to verify board operation:

- 1) Enable the SU converter by installing a shunt on jumper JU11. See Table 1 for jumper settings.
- 2) Preset the power supply to 2.4V. Turn the power supply off. **Caution: Do not turn on the power supply until all connections are completed.**
- 3) Connect the 2.4V power supply across the VBATT and GND pads.
- 4) Turn on the 2.4V power supply.
- 5) Verify that the voltage across the VSU and GND1 pads is approximately 5V. Connect a load, if desired, from VSU to GND1. See Table 2 for the output current.
- 6) Enable the MAIN, SD, SDZ, CCDBST, and CCDINV converters by installing shunts on jumpers JU7–JU10 and JU12.
- 7) Verify that the voltage across the VMAIN and GND2 pads is approximately 3.3V. Connect a load, if desired, from VMAIN to GND2. See Table 2 for output current.
- 8) Verify that the voltage across the VSDZ and GND4 pads is approximately 2.5V. Connect a load, if desired, from VSDZ to GND2. See Table 2 for output current.
- 9) Verify that the voltage across the VSD and GND3 pads is approximately 1.8V. Connect a load, if desired, from VSD to GND3. See Table 2 for output current.
- 10) Verify that the voltage across the VCCDBST and GND6 pads is approximately 15V. Connect a load, if desired, from VCCDBST to GND6. See Table 2 for output current.
- 11) Verify that the voltage across the VCCDINV and GND5 pads is approximately -7.5V. Connect a load, if desired, from VCCDINV to GND5. See Table 2 for output current.

Table 2. Default MAX8858 EV Kit Output Voltages and Typical Output Currents

OUTPUT	VOLTAGE (V)	CURRENT (mA)
VSU	5	500
VMAIN	3.3	300
VSDZ	2.5	200
VSD	1.8	250
VCCDBST	15	30
VCCDINV	-7.5	80

MAX8858 Evaluation Kit

Detailed Description of Hardware

The MAX8858 EV kit accepts inputs from 2-cell alkaline or 2-cell NiMH batteries. The MAX8858 provides six DC-DC converter channels to build a multiple-output DSC power-supply system: SU, MAIN, SDZ, SD, CCDBST, and CCDINV. The EV kit incorporates jumpers for ONSU, ONM/SEQ, ONZ/EN2, ONSD/EN1, ONBST, and ONINV to enable or disable each channel, respectively. Table 1 shows the details of the jumper functions. Table 2 lists the output voltages and currents for each channel.

SU Step-Up Converter (VSU)

The SU step-up converter (VSU) powers the internal circuitry of the MAX8858 and must reach its regulation voltage (5V) before any other output is allowed to turn on. Install a shunt on jumper JU11 (ONSU) to enable VSU. All outputs are shut down and the IC is in a low-power shutdown mode when VSU is disabled.

MAIN Step-Up Converter (VM)

The MAIN step-up converter (VM) is set to 3.3V. For independent (no preset power-up sequence) control of VM, install a shunt on jumper JU12 (ONM/SEQ) after VSU has reached regulation to enable VM. Remove the shunt to disable VM. To select a preset power-up sequence of VSD, VSDZ, and VM, install jumper JU12 before VSU reaches regulation. Jumpers JU7 and JU8 select the desired power-up sequence.

SD Step-Down Converter (VSD)

The SD step-down converter (VSD) is set to 1.8V. For independent (no preset power-up sequence) control of VSD, leave jumper JU12 (ONM/SEQ) unconnected and install jumper JU7 (ONSD/EN1) after SU has reached regulation. Remove the shunt to disable VSD. To select a preset power-up sequence of VSD, VSDZ, and VM, install jumper JU12 before VSU reaches regulation. Jumpers JU7 and JU8 select the desired power-up sequence.

SDZ Step-Down Converter (VSDZ)

The SDZ step-down converter (VSDZ) is set to 2.5V. For independent (no preset power-up sequence) control of VSDZ, leave jumper JU12 (ONM/SEQ) unconnected and install jumper JU8 (ONZ/EN2) after SU has reached regulation. Remove the shunt to disable VSDZ. To select a preset power-up sequence of VSD, VSDZ, and VM, install jumper JU12 before VSU reaches regulation. Jumpers JU7 and JU8 select the desired power-up sequence.

CCDBST Step-Up Converter (VCCDBST)

The CCDBST step-up converter (VCCDBST) is set to 15V. Install a shunt on jumper JU10 to enable VCCDBST. Remove the shunt to disable VCCDBST.

CCDINV Inverting Converter (VCCDINV)

The CCDINV inverting converter (VCCDINV) is set to -7.5V. Install a shunt on jumper JU9 to enable VCCDINV. Remove the shunt to disable VCCDINV. The active discharge circuit for VCCDINV is active for 10ms immediately after the removal of jumper JU9.

Customizing the MAX8858 Evaluation Kit

Adjusting the SU Step-Up Converter (VSU)

The SU step-up converter (VSU) is adjustable from 3.3V to 5V using the following procedure:

- 1) Choose R2 to be 100kΩ or less.
- 2) Solve for R1 using:
$$R1 = R2 \times [(V_{SU}/1.01V) - 1]$$
- 3) Install resistors R1 and R2.

Adjusting the MAIN Step-Up Converter (VM)

The input to the MAIN step-up converter (VM) is connected to BATT. VM is adjustable from 3.3V to V_{VSU} using the following procedure:

- 1) Choose R4 to be 10kΩ or less.
- 2) Solve for R3 using:
$$R3 = R4 \times [(V_{MAIN}/1.01V) - 1]$$
- 3) Install resistors R3 and R4.

Configuring the SD Step-Down Converter (VSD)

The input to the SD step-down converter (VSD) is connected to BATT by default. To connect the PVSD input to VSU, cut the trace shorting jumper JU2 and short-circuit JU1.

VSD is adjustable from 1.01V to V_{BATT} (or V_{SU}) using the following procedure:

- 1) Choose R6 to be 100kΩ or less.
- 2) Solve for R5 using:
$$R5 = R6 \times [(V_{SD}/1.01V) - 1]$$
- 3) Install resistors R5 and R6.

MAX8858 Evaluation Kit

Evaluates: MAX8858

Configuring the SDZ Step-Down Converter (VSDZ)

The input to the SDZ step-down converter (VSDZ) is connected to VSU by default. To connect the PVZ input to BATT, cut the trace shorting JU3 and short-circuit JU4.

VSDZ is adjustable from 1.01V to V_{VSU} (or V_{BATT}) using the following procedure:

- 1) Choose R8 to be 100kΩ or less.
- 2) Solve for R7 using:
$$R7 = R8 \times [(V_{SDZ}/1.01V) - 1]$$
- 3) Install resistors R7 and R8.

Adjusting the CCDBST Step-Up Converter (VCCDBST)

The input to the CCDBST step-up converter (VCCDBST) is connected to BATT. VCCDBST is adjustable from V_{BATT} to 18V using the following procedure:

- 1) Choose R10 to be 100kΩ or less.
- 2) Solve for R9 using:
$$R9 = R10 \times [(V_{CCDBST}/1.01V) - 1]$$
- 3) Install resistors R9 and R10.

Configuring the CCDINV Inverting Converter (VCCDINV)

The input to the CCDINV inverting converter (VCCDINV) is connected to BATT by default. To connect the PVINV input to VSU, cut the trace shorting JU5 and short-circuit JU6.

To adjust the CCDINV output voltage, use the following procedure:

- 1) Choose R12 to be 100kΩ or less.
- 2) Solve for R11 using:
$$R11 = R12 \times (|V_{CCDINV}|/1.25V)$$
- 3) Install resistors R11 and R12.

Note: For moderate to heavy loading on the CCDINV converter, adding a 100pF capacitor in parallel with R12 helps improve switching waveforms.

Power-Up Sequencing and On/Off Control (MAIN, SDZ, and SD Converters)

The MAX8858 provides both preset power-up sequencing and independent on/off control of the MAIN, SDZ, and SD converters. The state of ONM/SEQ is sampled when V_{VSU} reaches regulation to determine whether a preset power-up sequence or independent power-up control is selected. Install a shunt on JU12 before V_{VSU} reaches regulation to select a preset power-up sequence. Alternatively, leave JU12 unconnected before V_{VSU} reaches regulation to select independent on/off control of the MAIN, SDZ, and SD converters.

If JU12 is installed when V_{VSU} reaches regulation, a preset power-up sequence is selected. JU7 and JU8 determine which power-up sequence is selected. If a shunt is installed on JU7, power-up sequence 1 is selected, where the SDZ converter powers up first, followed by the SD converter, and finally, the MAIN converter (see Table 1 and Figure 4 in the MAX8858 IC data sheet). If a shunt is installed on JU8, power-up sequence 2 is selected, where the SD converter powers up first, followed by the SDZ converter, and finally, the MAIN converter (see Table 1 and Figure 5 in the MAX8858 IC data sheet). In both cases, the power-down sequence is the opposite of the power-up sequence, and each converter output is actively discharged. If JU12 is unconnected when V_{VSU} reaches regulation, independent control of the MAIN, SDZ, and SD converters is enabled. After V_{VSU} reaches regulation, JU12, JU7, and JU8 control the on/off behavior of the MAIN, SD, and SDZ converters, respectively (see Table 1 and Figure 6 in the MAX8858 IC data sheet). Each converter provides active-discharge circuitry, so that each output pulls to GND when its respective ON_ input is driven low.

MAX8858 Evaluation Kit

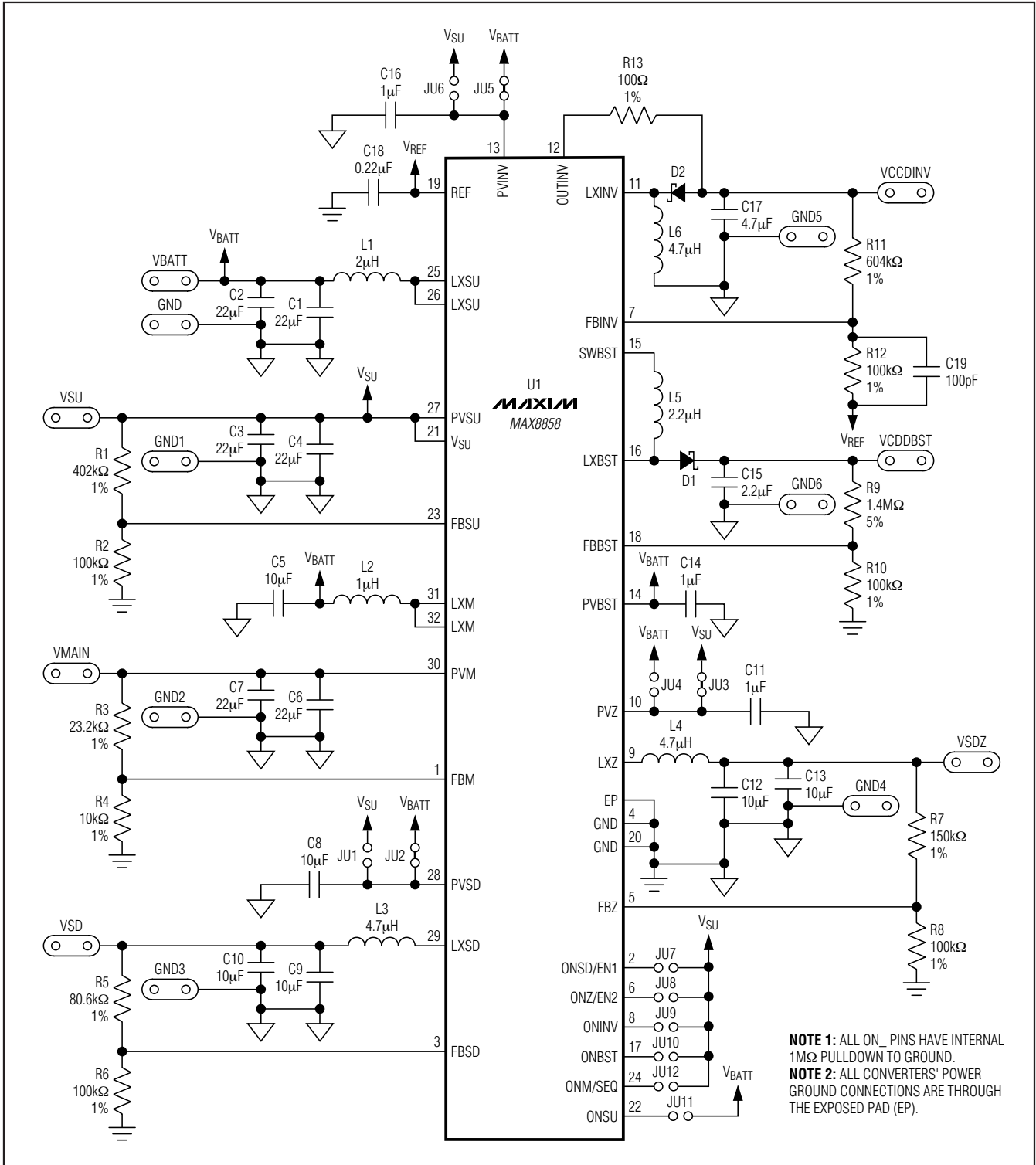

Figure 1. MAX8858 EV Kit Schematic Diagram

MAX8858 Evaluation Kit

Evaluates: **MAX8858**

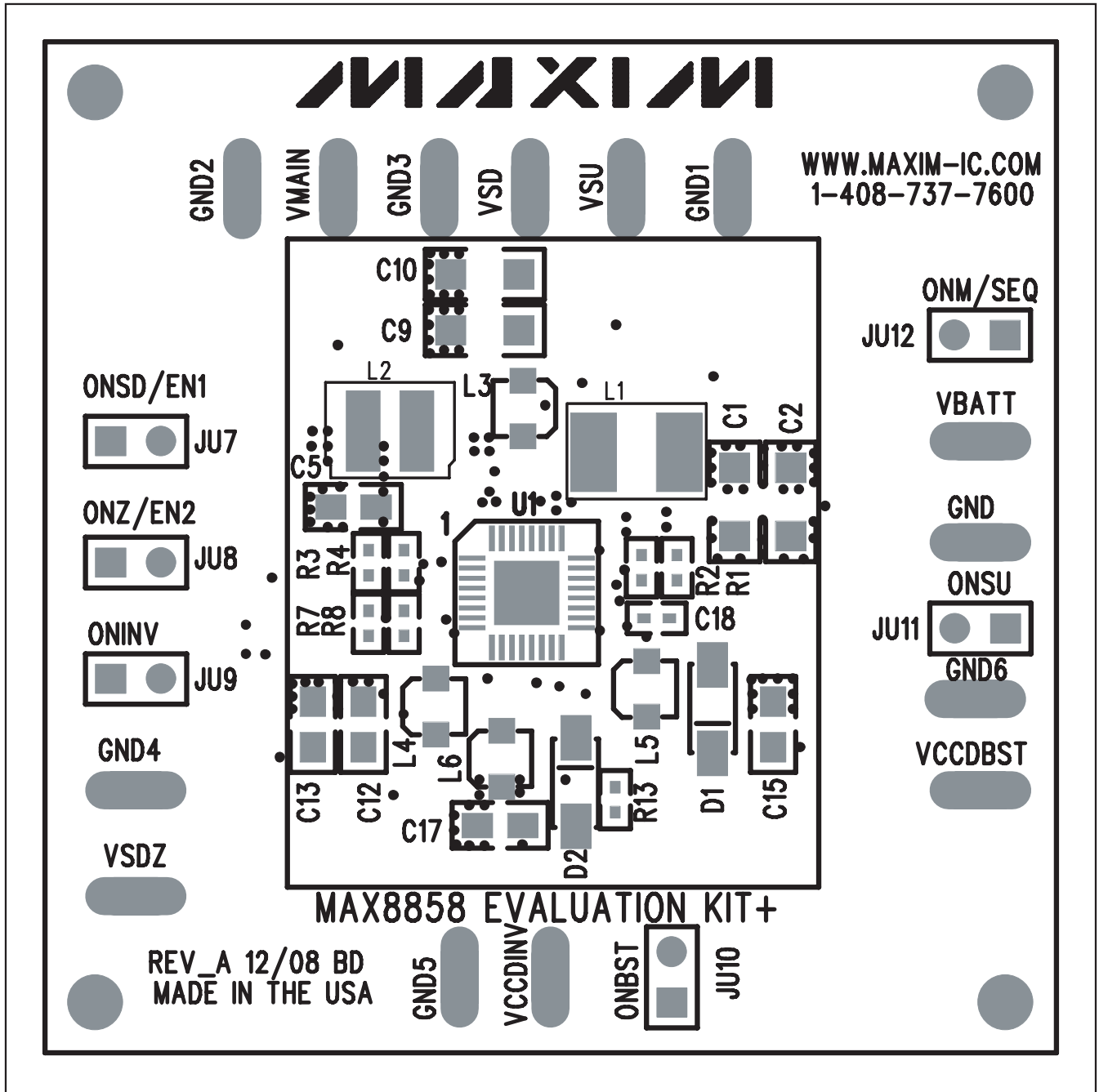

Figure 2. MAX8858 EV Kit Component Placement Guide—Top Layer

MAX8858 Evaluation Kit

Evaluates: MAX8858

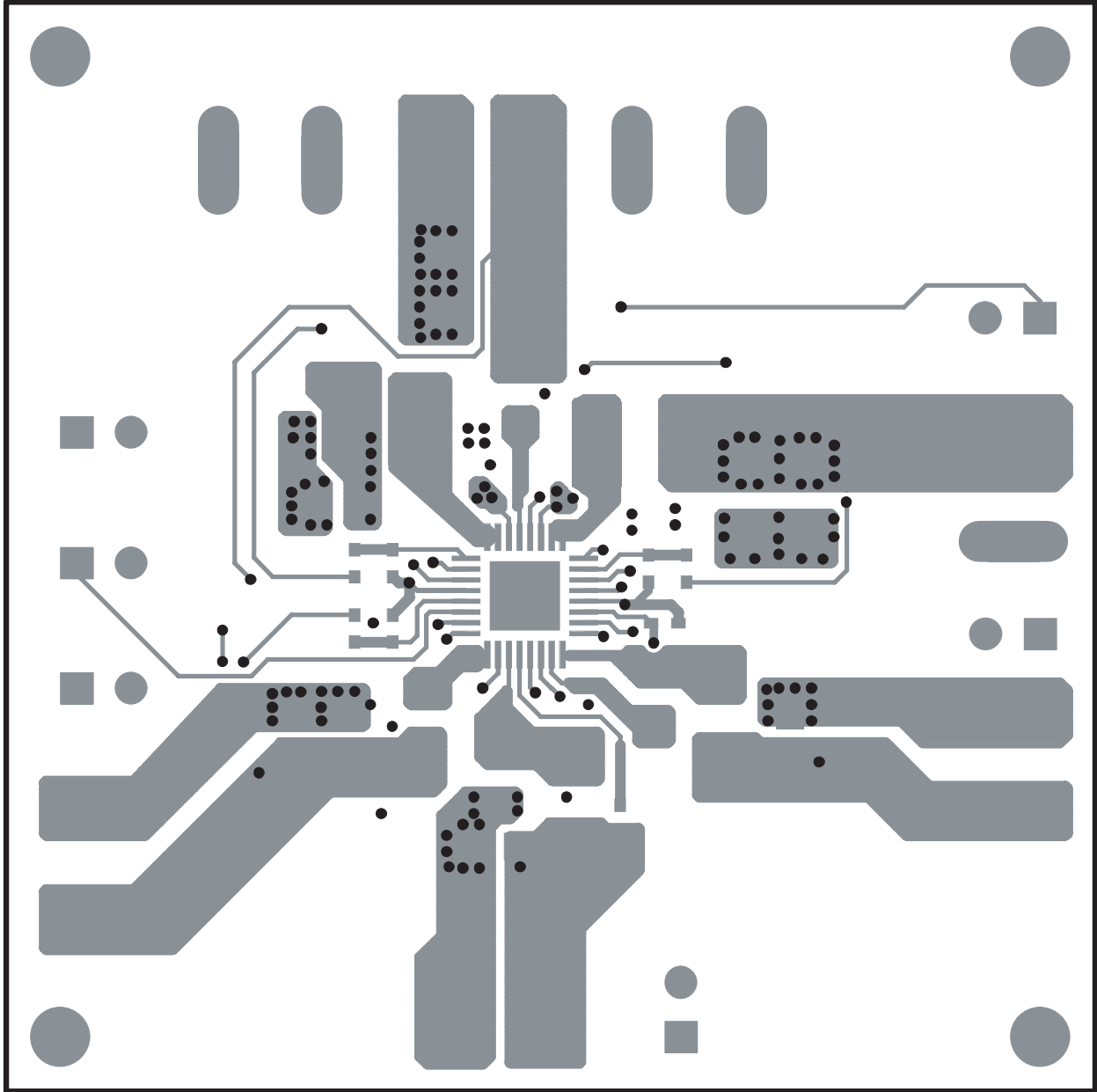

Figure 3. MAX8858 EV Kit PCB Layout—Top Layer

MAX8858 Evaluation Kit

Evaluates: MAX8858

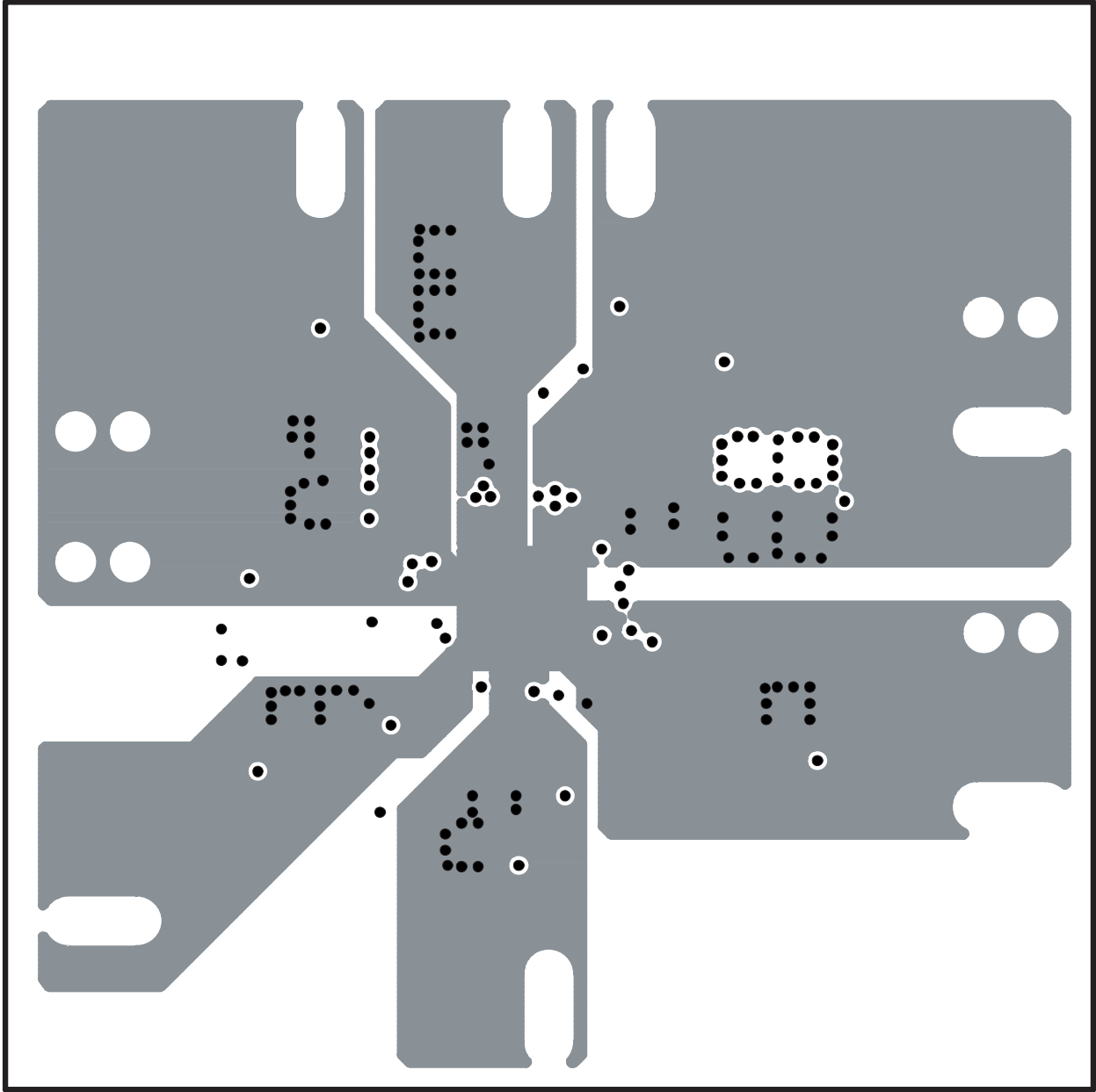

Figure 4. MAX8858 EV Kit PCB Layout—GND Inner Layer 2

MAX8858 Evaluation Kit

Evaluates: MAX8858

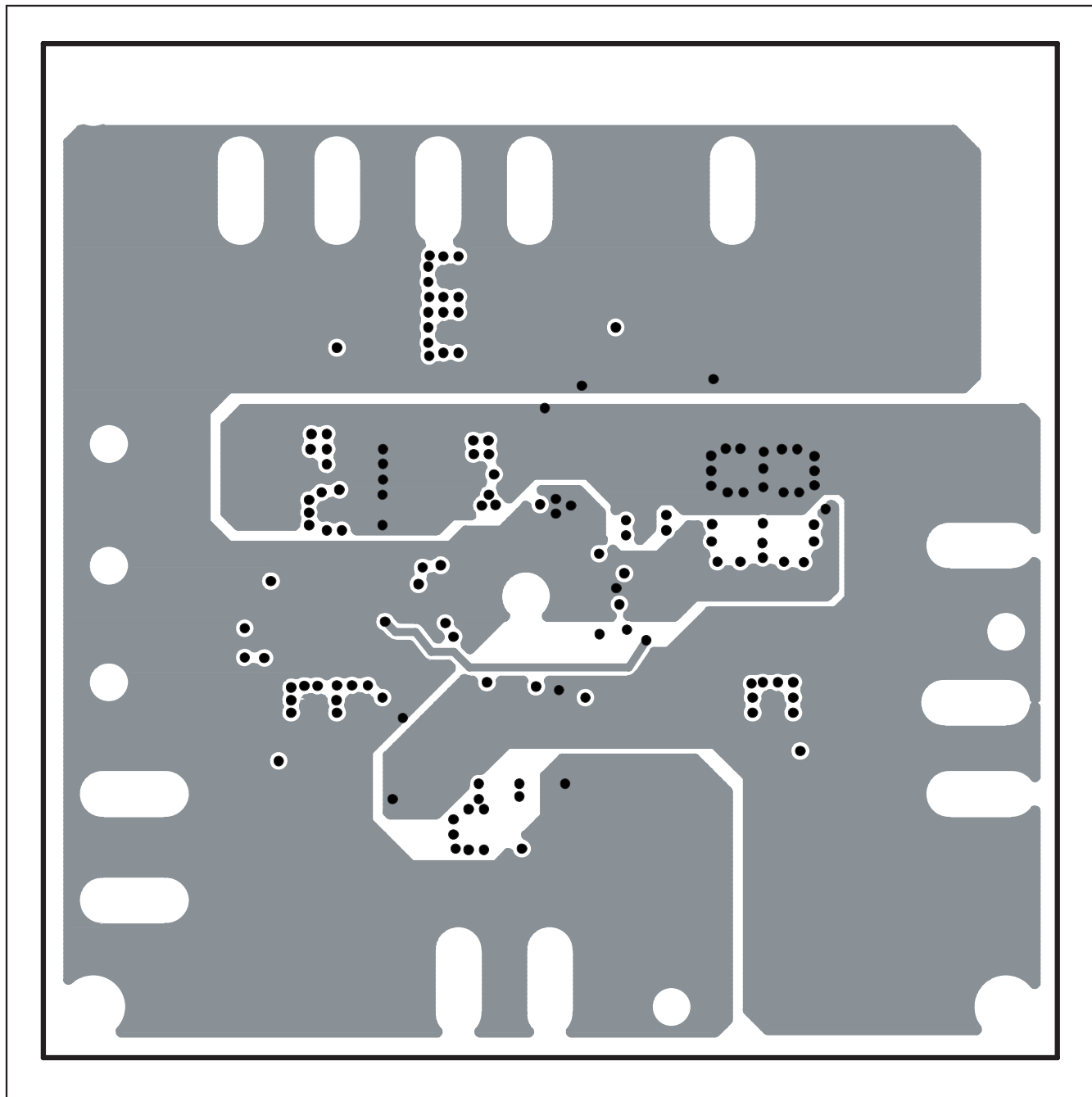

Figure 5. MAX8858 EV Kit PCB Layout—VSU/VBATT Layer 3

MAX8858 Evaluation Kit

Evaluates: MAX8858

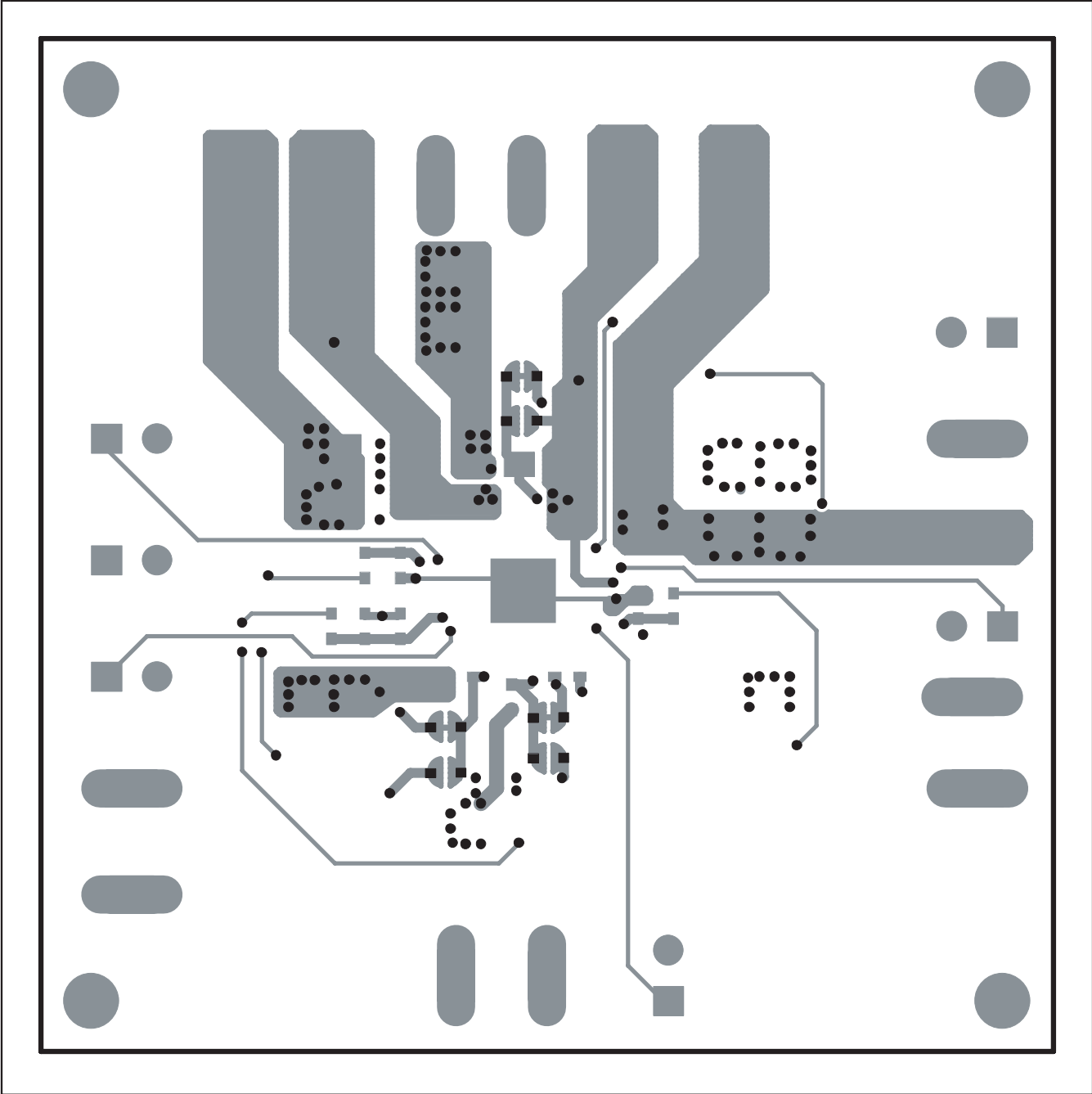

Figure 6. MAX8858 EV Kit PCB Layout—Bottom Layer

MAX8858 Evaluation Kit

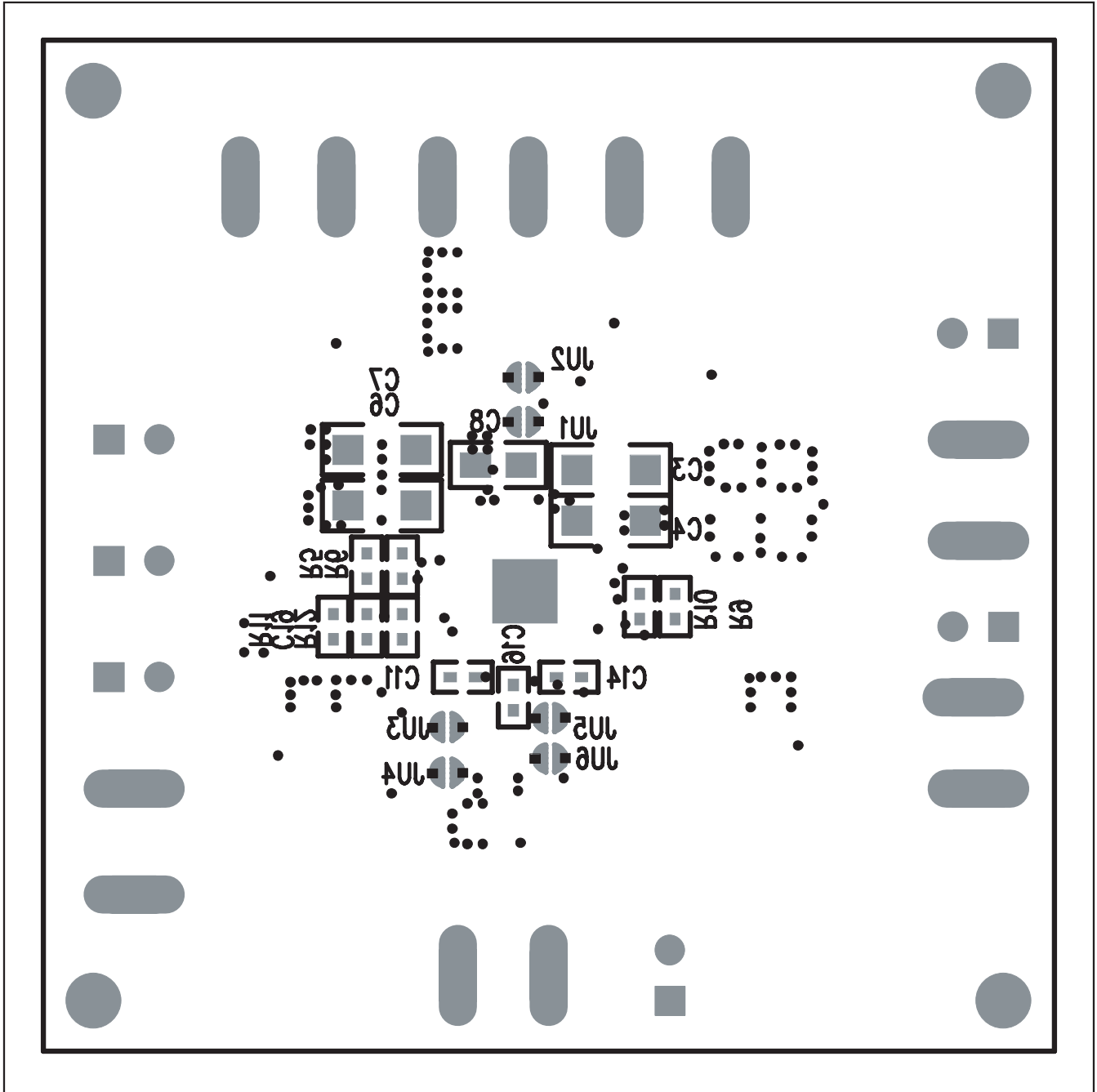

Figure 7. MAX8858 EV Kit Component Placement Guide—Bottom Layer

Maxim cannot assume responsibility for use of any circuitry other than circuitry entirely embodied in a Maxim product. No circuit patent licenses are implied. Maxim reserves the right to change the circuitry and specifications without notice at any time.