



MAX9736D Evaluation Kit

General Description

The MAX9736D evaluation kit (EV kit) is a fully assembled and tested PCB that configures the MAX9736D Class D amplifier to drive 2 x 6W into a pair of 8Ω speakers in stereo mode, or 1 x 12W into a 4Ω speaker in mono mode for audio applications. The EV kit operates from an 8V to 28V DC power supply and is configured for 17dB gain. The MAX9736D EV kit accepts a pair of single-ended input signals and provides two sets of differential outputs for speakers.

The MAX9736D EV kit provides an option to control the shutdown, mute, modulation scheme, and mono mode of the MAX9736D. The EV kit includes convenient audio input and output connectors and the required output filters to ease evaluation.

Features

- ◆ 8V to 28V Single DC Power-Supply Operation
- ◆ Fully Differential Outputs
- ◆ Drives 2 x 6W into 8Ω Speakers in Stereo Mode
- ◆ Drives 1 x 12W into 4Ω Speaker in Mono Mode
- ◆ Shutdown and Mute Control
- ◆ Selectable Modulation Scheme
- ◆ Evaluates the MAX9736D in 32-Pin TQFN-EP Package
- ◆ Fully Assembled and Tested

Ordering Information

PART	TYPE
MAX9736DEVKIT+	EV Kit

+ Denotes lead(Pb)-free and RoHS compliant.

Component List

DESIGNATION	QTY	DESCRIPTION
MINIMAL COMPONENTS FOR CUSTOMER DESIGN		
C1	1	150μF ±20%, 35V aluminum electrolytic capacitor (8mm x 11.5mm) Panasonic EEUFM1V151
C3, C4, C5	3	0.1μF ±10%, 50V X7R ceramic capacitors (0603) Murata GRM188R71H104K
C6	1	1μF ±10%, 16V X7R ceramic capacitor (0603) Murata GRM188R71C105K
C8, C9, C10	3	1μF ±10%, 10V X7R ceramic capacitors (0603) Murata GRM188R71A105K
C11, C12	2	1μF ±10%, 25V X7R ceramic capacitors (0805) Murata GRM21BR71E105K
R2–R5	4	20kΩ ±1% resistors (0603)

DESIGNATION	QTY	DESCRIPTION
OPTIONAL COMPONENTS FOR CUSTOMER EVALUATION		
C2	1	0.1μF ±10%, 50V X7R ceramic capacitor (0603) Murata GRM188R71H104K
C7	1	1μF ±10%, 10V X7R ceramic capacitor (0603) Murata GRM188R71A105K
C13–C16	0	Not installed, capacitors (0603)
C17–C26	10	0.15μF ±10%, 50V X7R ceramic capacitors (0805) Murata GRM21BR71H154K
D1	1	4.3V, 20mA zener diode (SOT23) Central Semi CMPZ5229B (Top Mark: C8D)
FB1	1	Ferrite bead, 22Ω at 100MHz, 10mΩ DCR, 6A (0805) Murata BLM21PG220SN1D
FOUTL-, FOUTL+, FOUTR-, FOUTR+, VDD, PGND	6	Binding posts
JU1	1	3-pin header
JU2–JU5	4	2-pin headers
JU6	0	Not installed, 2-pin header

MAX9736D Evaluation Kit

Component List (continued)

DESIGNATION	QTY	DESCRIPTION
L-, L+	2	PCB mini test points, 0.040in (white)
LIN	1	RCA phono jack, side entry, PCB mount (white)
L1-L4	4	15 μ H \pm 20%, 3.1A inductors Sumida CDRH104RNP-150NC
R-, R+	2	PCB mini test points, 0.040in (red)
RIN	1	RCA phono jack, side entry, PCB mount (red)
R1	1	10k Ω \pm 5% resistor (0603)
R6-R9	4	0 Ω \pm 5% resistors (0805)
R10-R13	4	15 Ω \pm 5% resistors (1206)

DESIGNATION	QTY	DESCRIPTION
R14-R18	5	100k Ω \pm 5% resistors (0603)
U1	1	Class D audio amplifier (32 TQFN-EP*) Maxim MAX9736DETJ+
—	5	Shunts
—	4	0.250in x 0.500in, 4-40 round nylon spacers
—	4	4-40 x 0.375in nylon machine screws
—	1	PCB: MAX9736D EVALUATION KIT+

*EP = Exposed pad.

Component Suppliers

SUPPLIER	PHONE	WEBSITE
Central Semiconductor Corp.	631-435-1110	www.centralsemi.com
Murata Electronics North America, Inc.	770-436-1300	www.murata-northamerica.com
Panasonic Corp.	800-344-2112	www.panasonic.com
Sumida Corp.	847-545-6700	www.sumida.com
TDK Corp.	847-803-6100	www.component.tdk.com
Würth Elektronik GmbH & Co. KG	201-785-8800	www.we-online.com

Note: Indicate that you are using the MAX9736D when contacting these component suppliers.

Quick Start

Required Equipment

- 8V to 28V, 4A DC power supply
- Audio source with volume control (e.g., CD player, etc.)
- Two speakers

Procedures

The MAX9736D EV kit is fully assembled and tested. Follow the steps below to verify board operation.
Caution: Do not turn on the power supply until all connections are completed.

- 1) Install a shunt across pins 1-2 of jumper JU1 (DVDD = 5V).
- 2) Install a shunt across jumper JU2 ($\overline{\text{SHDN}}$ = high, EV kit enabled).
- 3) Install a shunt across jumper JU3 (REGEN = high, internal regulator enabled).
- 4) Install a shunt across jumper JU4 ($\overline{\text{MUTE}}$ = high, output enabled).
- 5) Install a shunt across jumper JU5 (MOD = high, filterless modulation scheme).
- 6) Connect the first speaker across the FOUTL- and FOUTL+ PCB binding posts.
- 7) Connect the second speaker across the FOUTR- and FOUTR+ PCB binding posts.
- 8) Connect the positive terminal of the power supply to the VDD binding post and the power-supply ground terminal to the PGND binding post.
- 9) Connect the left output terminal of the audio source to the LIN RCA phono jack.
- 10) Connect the right output terminal of the audio source to the RIN RCA phono jack.
- 11) Turn on the audio source at minimum volume.
- 12) Turn on the power supply.
- 13) Gradually increase the audio source volume until audio is heard through the loud speakers.

MAX9736D Evaluation Kit

Detailed Description of Hardware

The MAX9736D EV kit is designed to evaluate the MAX9736D in a 32-pin TQFN-EP package. The MAX9736D is a Class D amplifier that can be configured to drive 2 x 6W into a pair of 8Ω speakers, or 1 x 12W into a 4Ω speaker. The EV kit operates from a DC power supply that provides 8V to 28V and 4A of current. The EV kit PCB is designed with two layers and only requires 1oz copper for power dissipation. The MAX9736D EV kit accepts a pair of single-ended input signals and provides two sets of amplified differential audio outputs.

Optional External Preamplifier Power Supply (VS)

The MAX9736D EV kit provides an input pad to accept an optional 5V external power supply for powering the MAX9736D preamplifiers when the internal regulator is disabled. Disable the internal regulator by removing the shunt from jumper JU3 before connecting an external power supply between the VS and AGND pads on the MAX9736D EV kit (see Table 4). The external power supply for the preamplifiers must be in the 4.5V to 5.5V range. Refer to the *Power Sequencing* section in the MAX9736D IC data sheet before operating with optional external preamplifier power supply.

Filtered Output

Audio analyzers typically cannot accept pulse-width-modulated (PWM) signals at their inputs. Therefore, the MAX9736D EV kit features a pair of lowpass filters at each of the outputs to ease evaluation. Use the filtering output posts (FOUTL+/FOUTL- and FOUTR+/FOUTR-) to connect the filtered PWM outputs to the audio analyzer. The default lowpass filters at the EV kit outputs are optimized for a pair of 8Ω speakers.

Filterless Output

The MAX9736D EV kit's filterless outputs (L+/L- and R+/R-) can be connected directly to a pair of speaker loads without any filtering. Use the L+/L- and R+/R- test points to connect speakers directly to the MAX9736D outputs using twisted-pair cable. Remove inductors L1–L4 for maximum efficiency.

Output Filtering Requirements

To ease evaluation, the MAX9736D EV kit is shipped with inductor-based output filters. However, the MAX9736D can pass EC EN55022 regulations with only ferrite-bead filters, especially when speaker-wire lengths are less than 1m.

To install the ferrite-bead filters, first remove the large filter inductors (L1–L4). Next, replace resistors R6–R9 with ferrite beads listed in Table 1 (provided with the EV kit), and install filter capacitors on the C13–C16 pads.

The speaker wire should be connected to L+, L-, R+, and R- test points using twisted-pair cable.

Although component selection for the output filter is dependent on speaker-wire length, the components in Table 1 are provided with the EV kit as a starting point. Final component selection should be determined during EMC testing. Contact the factory if required.

Table 1. Recommended EMI Filter Components for 8Ω Loads

COMPONENT	DESCRIPTION
R6–R9*	Ferrite beads, 600Ω at 100MHz, 150mΩ DCR, 2A (0805) Würth 742792040
C13–C16	330pF ±10%, 50V X7R ceramic capacitors (0603) Murata GRM188R71H331K or TDK C1608X7R1H331K

*3A current-rating ferrite beads are recommended for 4Ω load drive.

Jumper Selection

Digital Inputs Power Supply (DVDD)

The MAX9736D EV kit operates from a DC power supply between 8V and 28V. This power-supply range is too high for the digital input pins on the MAX9736D IC. The EV kit includes a circuit to regulate the input power supply to 3V for powering all the logic circuits on the EV kit. Jumper JU1 sets the DVDD voltage (see Table 2 for shunt positions).

Table 2. JU1 Jumper Selection (DVDD)

SHUNT POSITION	DVDD REGULATED TO (V)	EV KIT DIGITAL INPUT POWER
1-2*	3	On
2-3	0	Off

*Default position.

Shutdown Mode ($\overline{\text{SHDN}}$)

The MAX9736D features a shutdown mode to reduce the quiescent current. Jumper JU2 controls the shutdown ($\overline{\text{SHDN}}$) pin of the MAX9736D IC (see Table 3 for shunt positions).

Table 3. JU2 Jumper Selection ($\overline{\text{SHDN}}$)

SHUNT POSITION	$\overline{\text{SHDN}}$ PIN CONNECTED TO	EV KIT FUNCTION
Installed*	DVDD	EV kit enabled
Not installed	PGND (through resistor R14)	Shutdown mode

*Default position.

MAX9736D Evaluation Kit

Internal Regulator Enable (REGEN)

The MAX9736D provides an option to disable the internal regulator when an optional external power supply is connected to the VS and AGND pads on the EV kit to power the MAX9736D preamplifiers. Jumper JU3 controls the internal regulator enable (REGEN) pin on the MAX9736D IC (see Table 4 for shunt positions). See the *Optional External Preamplifier Power Supply (VS)* section.

Mute Function ($\overline{\text{MUTE}}$)

The MAX9736D features a mute function to mute the audio output of the EV kit. Jumper JU4 controls the mute ($\overline{\text{MUTE}}$) pin of the MAX9736D IC (see Table 5 for shunt positions).

Modulation Scheme (MOD)

The MAX9736D EV kit provides an option to select the modulation scheme for the MAX9736D output. Jumper JU5 controls the modulation-scheme pin (MOD) of the MAX9736D IC (see Table 6 for shunt positions).

Mono Mode (MONO)

The MAX9736D EV kit is preconfigured to stereo mode from the factory. To change the MAX9736D EV kit to operate in mono mode, short jumper JU6 with a shorting wire, connect the FOUTL- to the FOUTR- with a short banana-lead cable and connect the FOUTL+ to the FOUTR+ with a short banana-lead cable. Connect the audio input source to the LIN RCA jack. In mono mode, the right input (RIN) becomes an uncommitted inverting op amp that can be used for filtering. Jumper JU6 controls the mono mode for the MAX9736D IC (see Table 7 for shunt positions).

Table 4. JU3 Jumper Selection (REGEN)

SHUNT POSITION	REGEN PIN CONNECTED TO	EV KIT INTERNAL REGULATOR
Installed*	DVDD	Enabled
Not installed	PGND (through resistor R15)	Disabled

*Default position.

Table 5. JU4 Jumper Selection ($\overline{\text{MUTE}}$)

SHUNT POSITION	$\overline{\text{MUTE}}$ PIN CONNECTED TO	AUDIO OUTPUT
Installed*	DVDD	Normal operation
Not installed	PGND (through resistor R16)	Muted

*Default position.

Table 6. JU5 Jumper Selection (MOD)

SHUNT POSITION	MOD PIN CONNECTED TO	OUTPUT MODULATION SCHEME
Installed*	DVDD	Filterless modulation
Not installed	PGND (through resistor R17)	Classic PWM

*Default position.

Table 7. JU6 Jumper Selection (MONO)

SHUNT POSITION	MONO PIN CONNECTED TO	OUTPUT SPEAKER MODE	AUDIO INPUT SOURCE CONNECTED TO
Not installed*	PGND (through resistor R18)	Stereo mode	LIN and RIN
Install a shorting wire	DVDD	Mono mode	LIN (RIN is an uncommitted inverting op amp)

*Default position.

MAX9736D Evaluation Kit

Evaluates: MAX9736D

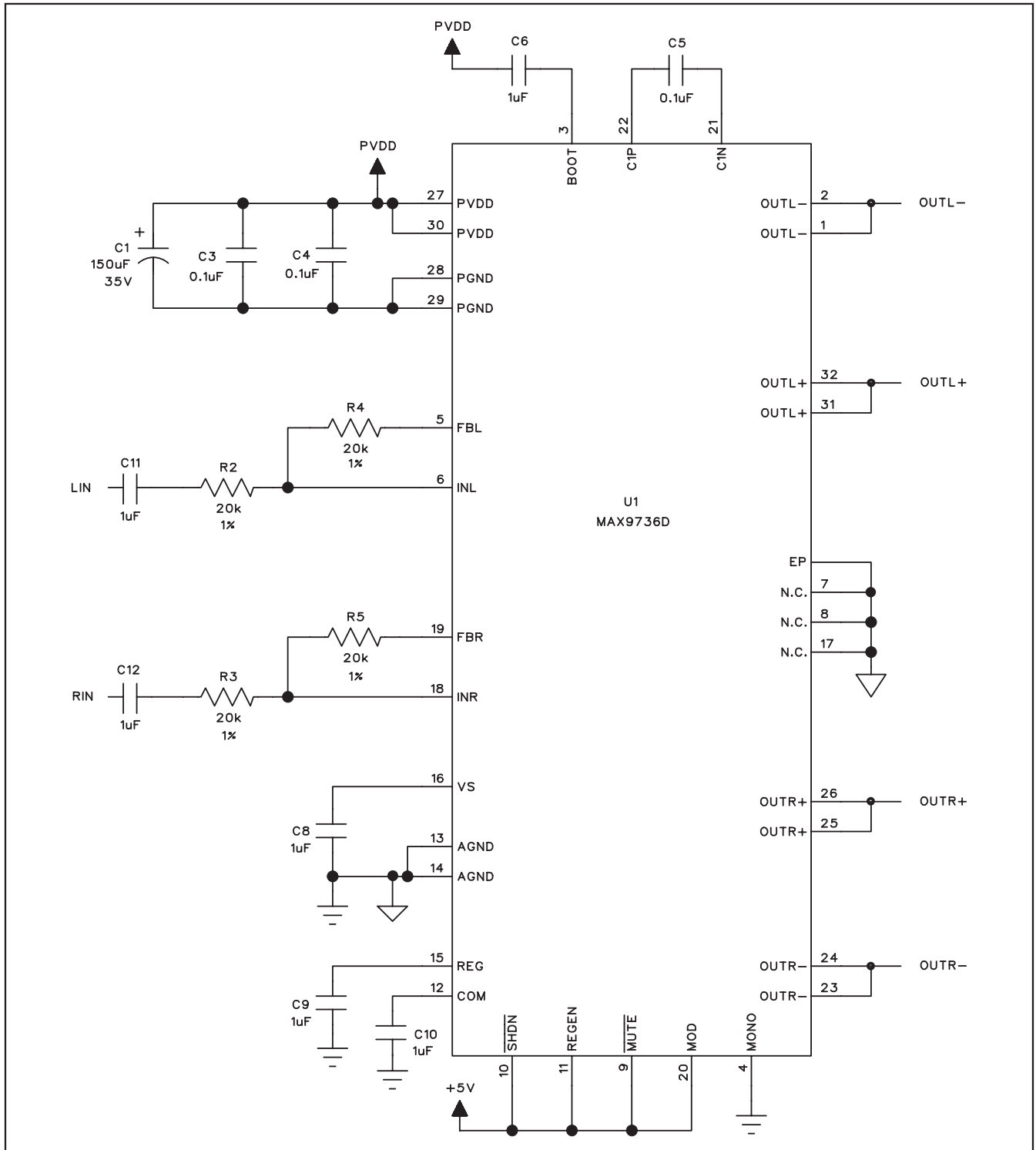

Figure 1. MAX9736D Customer Design Schematic

MAX9736D Evaluation Kit

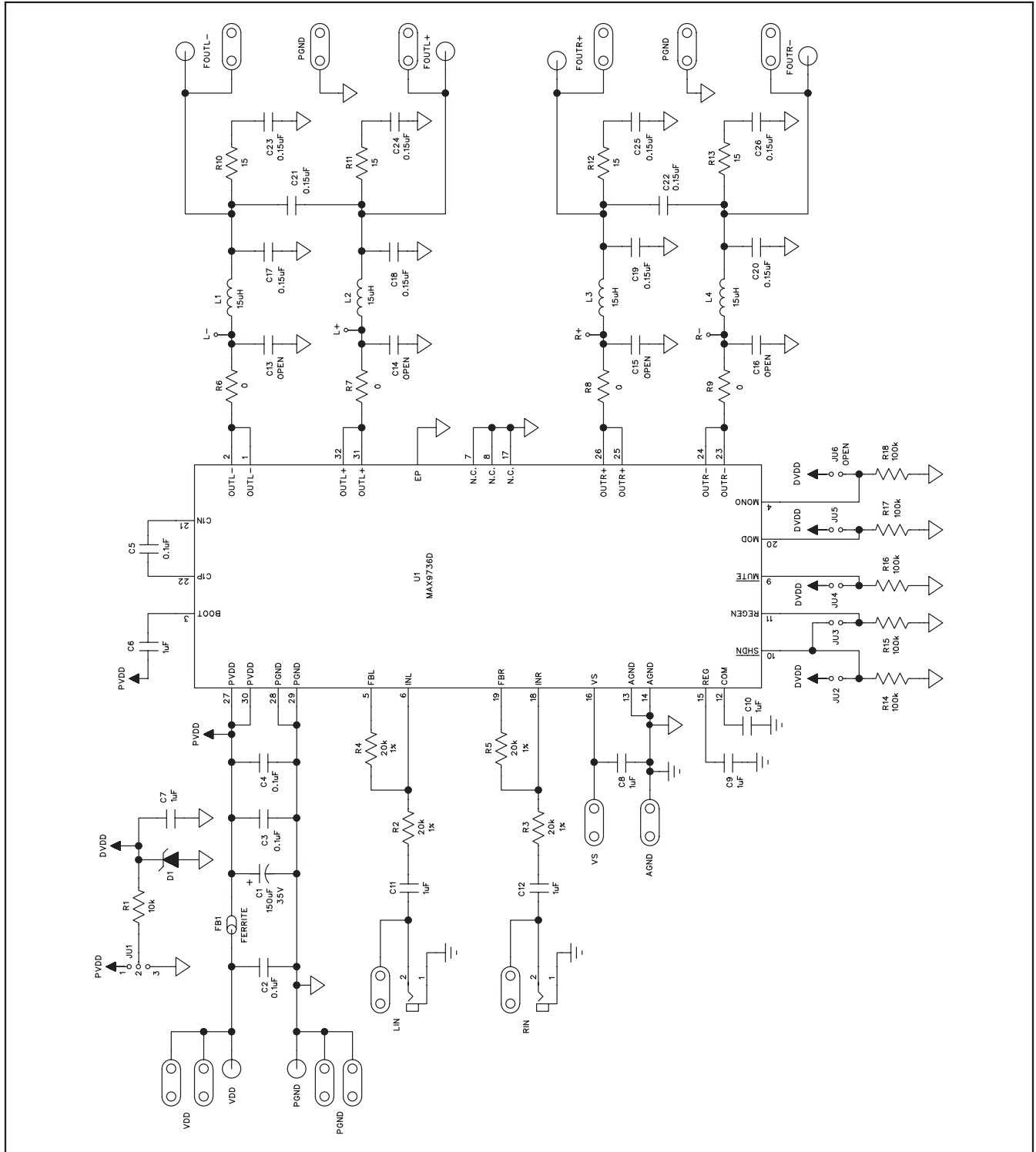

Figure 2. MAX9736D EV Kit Schematic

MAX9736D Evaluation Kit

Evaluates: MAX9736D

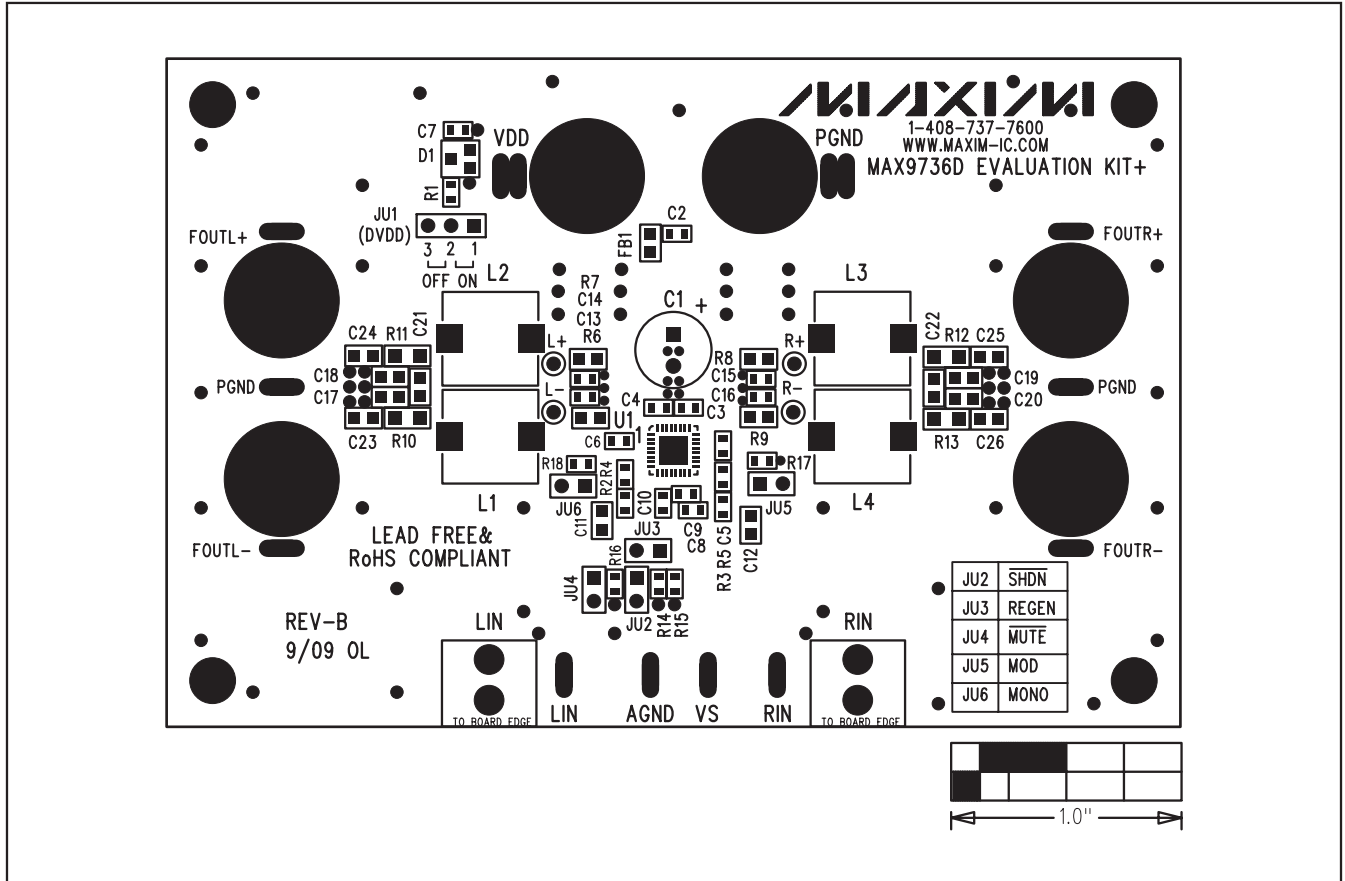

Figure 3. MAX9736D EV Kit Component Placement Guide—Component Side

MAX9736D Evaluation Kit

Evaluates: MAX9736D

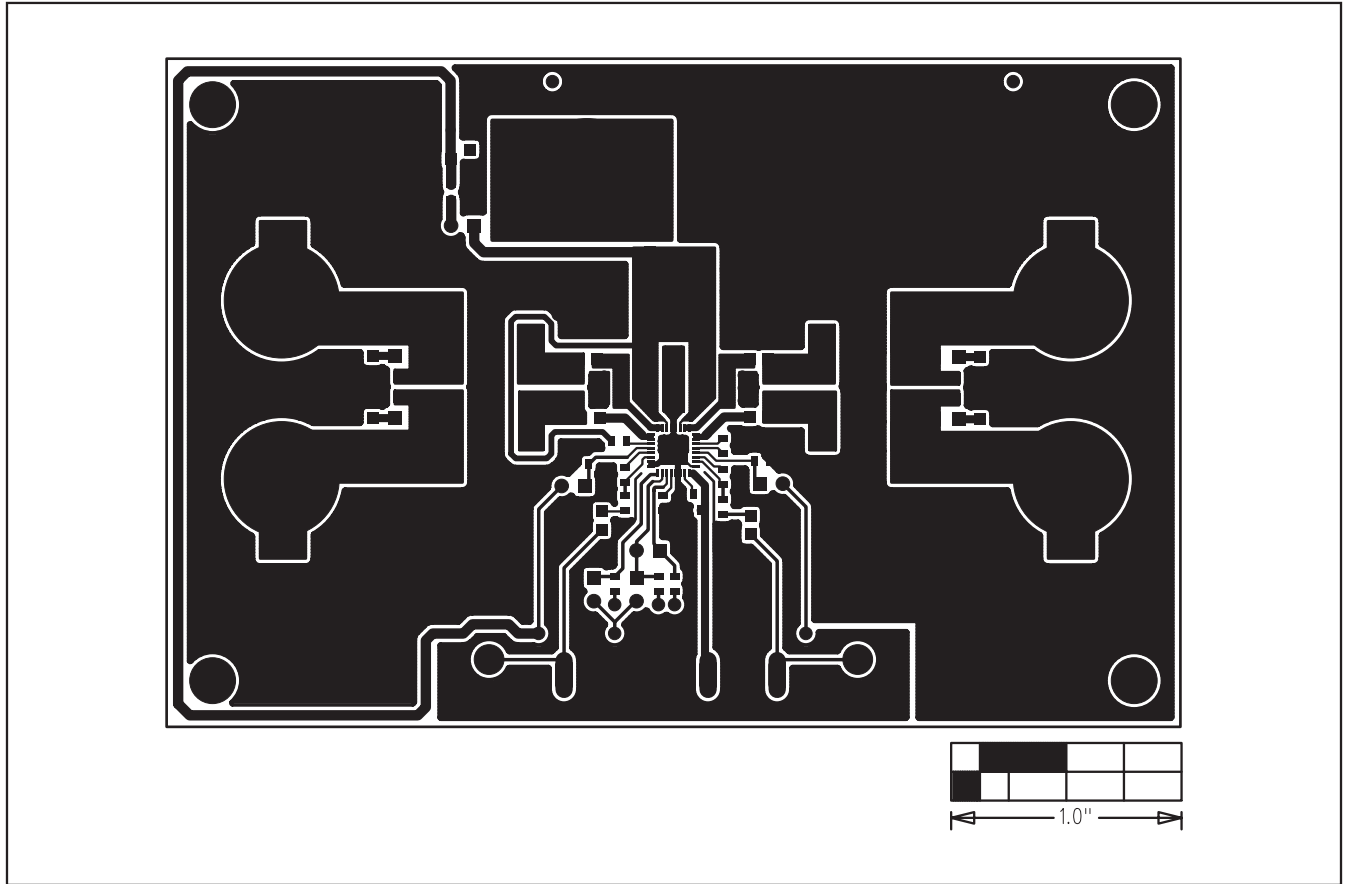

Figure 4. MAX9736D EV Kit PCB Layout—Component Side

MAX9736D Evaluation Kit

Evaluates: MAX9736D

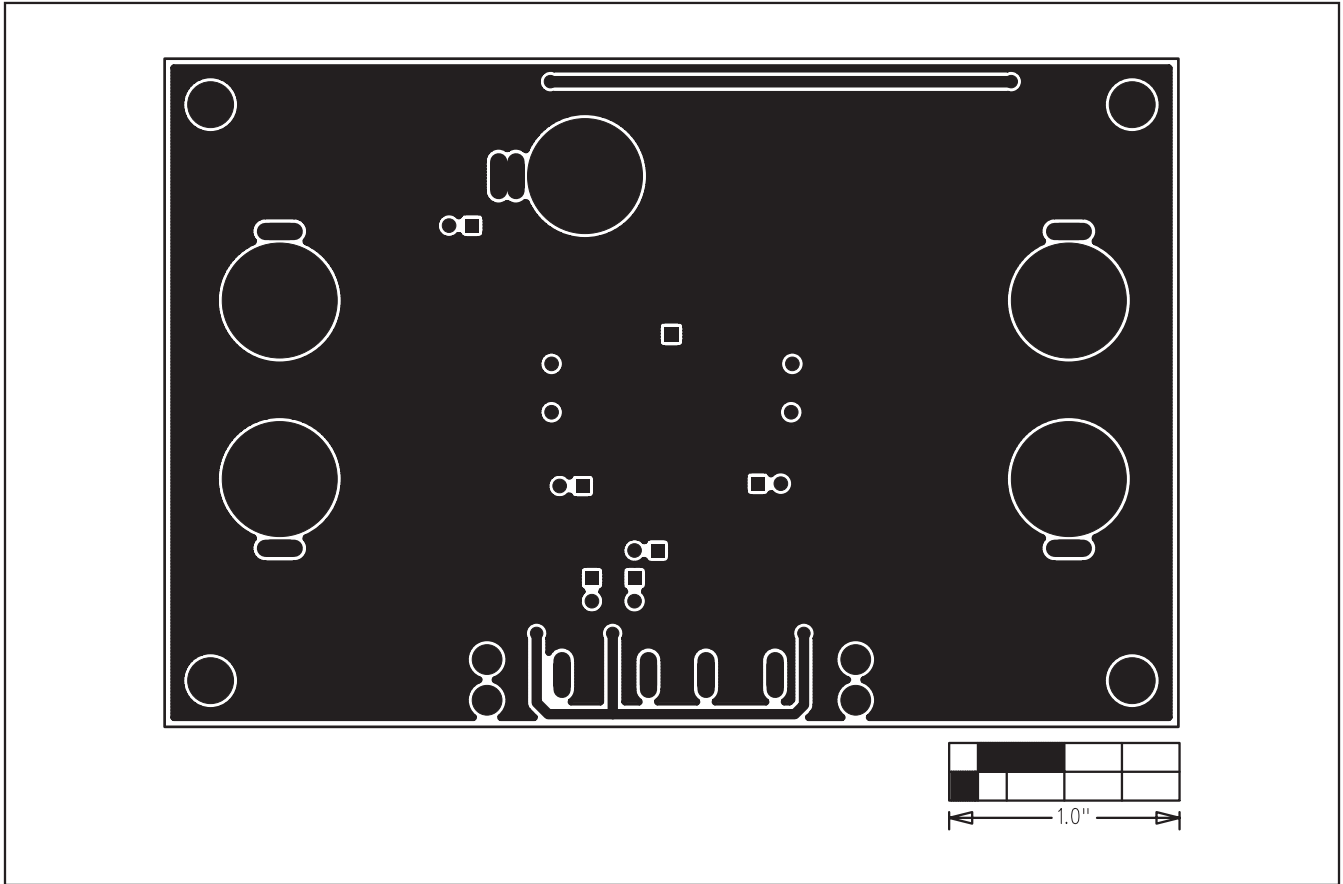

Figure 5. MAX9736D EV Kit PCB Layout—Solder Side

Maxim cannot assume responsibility for use of any circuitry other than circuitry entirely embodied in a Maxim product. No circuit patent licenses are implied. Maxim reserves the right to change the circuitry and specifications without notice at any time.

Maxim Integrated Products, 120 San Gabriel Drive, Sunnyvale, CA 94086 408-737-7600 _____ 9