

## General Description

The MAX98091 evaluation kit (EV kit) is a fully assembled and tested circuit board that evaluates the MAX98091 audio codec. The MAX98091 is an integrated audio codec including an earpiece amplifier, stereo Class D amplifier, stereo DirectDrive® headphone amplifier, and digital signal processing.

To enable easy connection to a wide range of audio sources, the EV kit includes audio devices to convert both USB and S/PDIF data to I<sup>2</sup>S data. The EV kit also integrates a MAXQ2000 microcontroller to enable I<sup>2</sup>C and SPI communication with the on-board I<sup>2</sup>C- and SPI-capable devices. A simple and intuitive graphical user interface (GUI) provides communication with the EV kit through Windows® OS running Windows XP®, Windows 7-, or Windows 8-compatible software.

## Features

- 2.8V to 5.5V Single-Supply Operation
- On-Board USB-to-I<sup>2</sup>C Interface
- On-Board USB-to-I<sup>2</sup>S Converter
- On-Board S/PDIF Transceiver
- On-Board Clock Source
- On-Board Digital Microphone
- Windows XP-, Windows 7-, and Windows 8-Compatible Software
- Fully Assembled and Tested

*Ordering Information appears at end of data sheet.*

## Simplified EV Kit Block Diagram

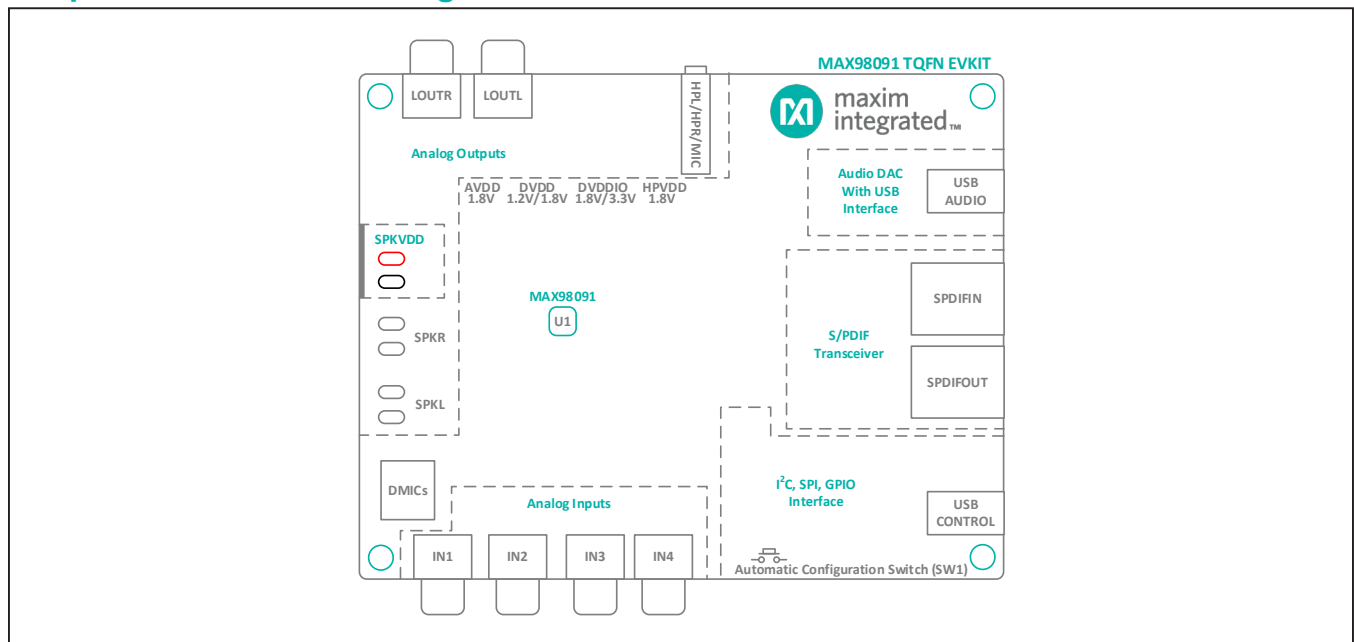

DirectDrive is a registered trademark of Maxim Integrated Products, Inc.

Windows and Windows XP are registered trademarks and registered service marks of Microsoft Corporation.

**Quick Start**

**Required Equipment**

- MAX98091 EV kit (TQFN)
- Two A to mini-B USB cables (included)
- 2.8V to 5.5V, 2A DC power supply
- Set of headphones with a 3.5mm plug
- User-supplied Windows XP, Windows 7, or Windows 8 PC with two available USB ports

**Note:** In the following sections, software-related items are identified by bolding. Text in **bold** refers to items directly from the EV kit software. Text in **bold and underlined** refers to items from the Windows operating system.

**Procedure**

The following steps are used to configure the EV kit for PC audio playback to verify the EV kit’s functionality:

- 1) Visit [www.maximintegrated.com/evkitsoftware](http://www.maximintegrated.com/evkitsoftware) to download the latest version of the MAX98091 software, MAX98091EVSwSetupVx.x.ZIP. Save the software to a temporary folder and uncompress the ZIP file.
- 2) Install the software and USB driver on your computer by running the executable (.exe) program inside the temporary folder. The program files are copied and icons are created in the Windows **Start | Programs | Maxim Integrated | MAX98091 | Evaluation Software** menu. During software installation, some versions of Windows might show a message indicating that this software is from an unknown publisher. This is not an error condition and it is safe to proceed with the installation.
- 3) Verify that all jumpers are in their default positions, as shown in [Figure 1](#) (same as listed in [Table 2](#)).
- 4) Connect the power supply between the SPKVDD and GND PCB pads.
- 5) Set the power supply to 4.2V with a 2A current limit and turn it on.

- 6) Connect a USB cable between the PC and the J1 USB port (USB CONTROL) on the EV kit. A Windows message appears when connecting to the EV kit for the first time. Each version of Windows might have a slightly different message. If Windows reports that the device is ready to use, then the USB driver has been installed successfully.
- 7) If needed, the USB driver can be manually installed by navigating to the **C:\Program Files(x86)\Maxim Integrated\MAX98091\Evaluation Software** folder (default installation directory) and following the instructions in the **USB\_Driver\_Help.PDF** document. The help file is located in the **USBDriver** folder.
- 8) Connect the headphones to the headphone jack (HP).
- 9) Start the MAX98091 Evaluation Software by opening its icon in the **Start | Programs | Maxim Integrated | MAX98091 | Evaluation Software** menu. The software main window appears, as shown in [Figure 3](#).
- 10) Wait while the software connects to the EV kit. Once the connection is established, the status bar at the bottom indicates that the USB and MAX98091 are connected.
- 11) Once the USB and device connections have been established, select the **Block Diagram** tab.
- 12) Click on the **USB** block.
- 13) Click **Yes** to automatically configure the EV kit for USB audio playback.
- 14) Connect a USB cable between the PC and the J2 USB port (USB AUDIO). Windows automatically detects the EV kit as a sound card and installs the USB audio class drivers.
- 15) Open Windows’ **Sound** dialog and select the **Playback** tab. A **USB Audio DAC** item, similar to [Figure 2](#), is added to the list of available playback devices. All audio played through this device is sent to the EV kit.
- 16) Verify that the **USB Audio DAC** item is set as the default device.
- 17) Verify that audio can be heard through the connected headphones.
- 18) Quick start complete. Refer to the MAX98091 IC data sheet for additional information.

**Table 1. MAX98091 Software Install Folder**

ITEM	DESCRIPTION
MAX98091.exe	MAX98091 evaluation software
USBDriver/FTDI/CDM21000.exe	USB driver installer
USBDriver/USB_Driver_Help_300.pdf	USB driver installation help file
Uninstall.exe	Uninstalls the MAX98091 evaluation software

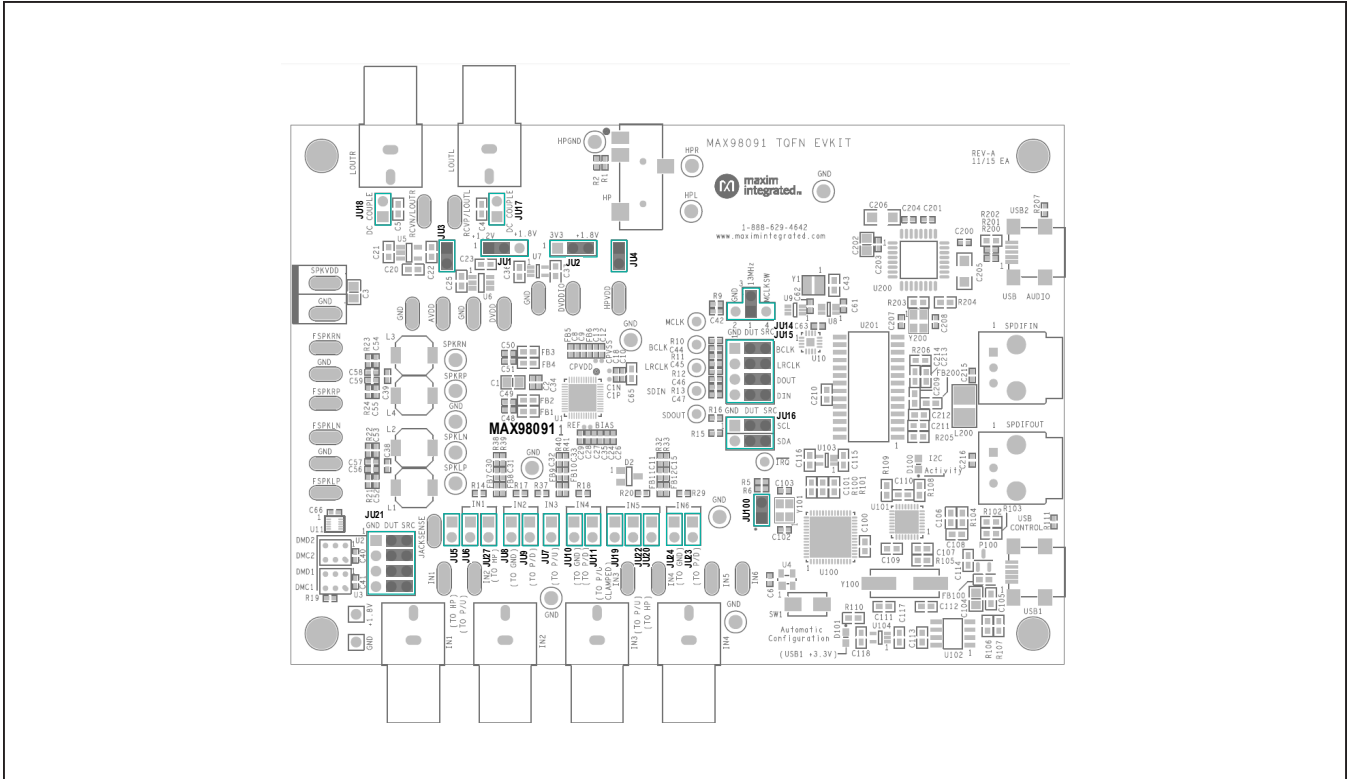

Figure 1. Default Shunt Configuration

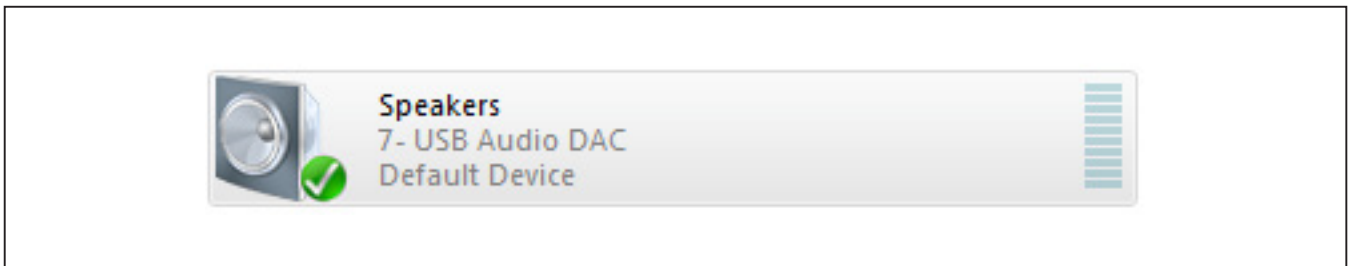

Figure 2. Playback Device

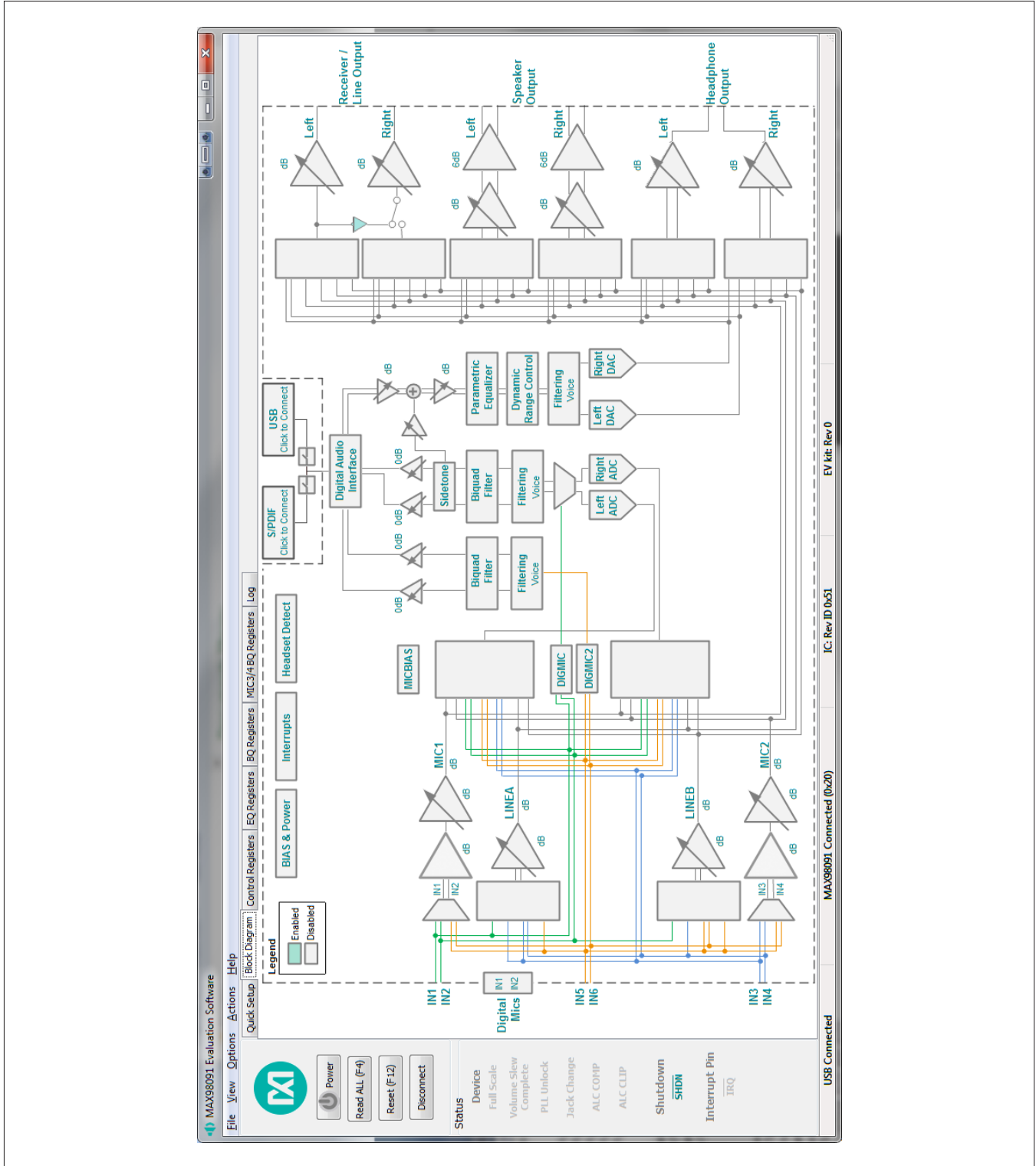

Figure 3. MAX98091 Software Main Window

## Detailed Description of Software

The MAX98091 EV kit is intended to be evaluated with the MAX98091 software, as it provides an intuitive graphical user interface (GUI) for programming the MAX98091 device and also includes a handful of features that are intended to aid evaluation.

The MAX98091 software main window is divided into three sections: software buttons, status panel, and tabbed pages (Figure 3). The buttons provide basic functionality and the status panel provides monitoring capabilities. The tabbed pages provide the controls for programming the MAX98091.

The **Quick Setup** tab provides access to the device's quick setup registers (0x04–0x0B). The **Block Diagram** tab provides access to all the device registers and utilizes diagram blocks to access dialog windows. The dialogs contain the GUI controls used to program the device. The **Control Registers** tab provides access to registers 0x00–0x45 as well as to the revision ID register, 0xFF. The **EQ Registers** tab provides access to the device's parametric equalizer (EQ), registers 0x46–0xAE. The **BQ Registers** tab provides access to the device's biquad (BQ) filter, registers 0xAF–0xBD. The **MIC3/4 BQ Registers** tab provides access to the biquad (BQ) filter, registers 0xC3–0xD1, in the DIGMIC2 path.

Go to [www.maximintegrated.com/evkitsoftware](http://www.maximintegrated.com/evkitsoftware) to download the MAX98091 software. When evaluating with the EV kit and software, it is recommended that this document be used in conjunction with the MAX98091 IC data sheet.

## Software Buttons

There are four buttons available on the main window of the MAX98091 software: **Power**, **Read All (F4)**, **Reset (F12)**, and **Connect**. These buttons are always accessible, regardless of the active tab.

### Power

The **Power** button programs the MAX98091's  $\overline{\text{SHDN}}$  bit to enable/disable the device. When the device is disabled/enabled, the button image is gray/blue, respectively. When the device is in shutdown ( $\overline{\text{SHDN}}$  bit = 0) the software is still able to communicate with the device, as its I<sup>2</sup>C interface remains active.

### Read All (F4)

The **Read All (F4)** button performs the following sequence of reads and updates the associated register tab. This function is also available from the **Actions** menu.

- Read the MAX98091  $\overline{\text{IRQ}}$  pin. This only updates the **Status** panel.
- Read the status register (0x01). This also updates the **Status** panel.
- Read control registers (0x03–0x45).
- Read parametric equalizer registers (only if the **EQ Registers** tab is visible or if EQ bands are enabled).
- Read biquad registers (only if the **BQ Registers** tab is visible or if the biquad filter is enabled).
- Read Revision ID register (0xFF).
- Read S/PDIF Transceiver (U201) registers.

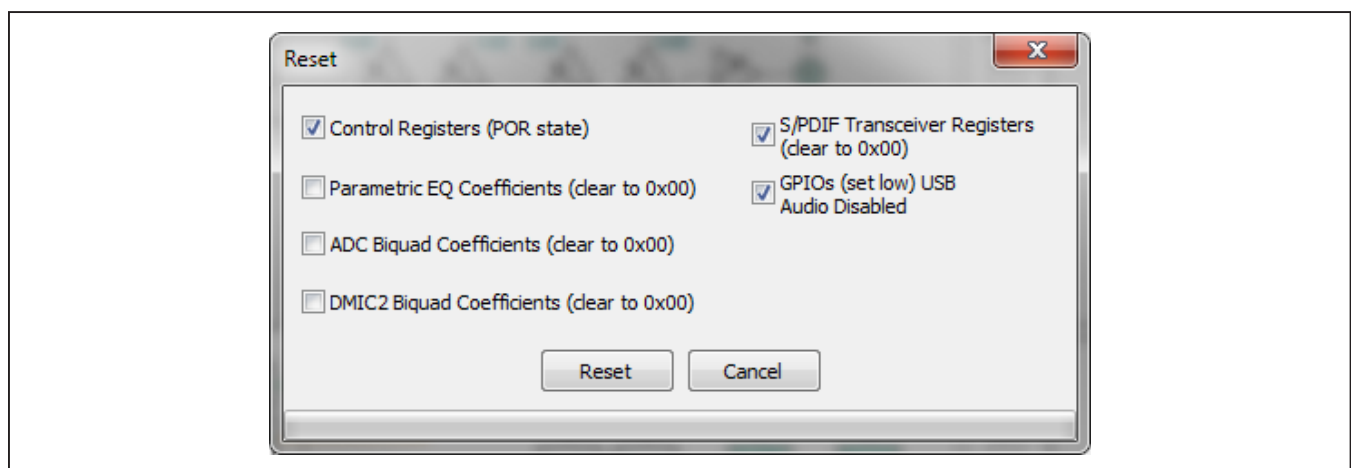

Figure 4. Reset Dialog

### Reset (F12)

The **Reset (F12)** button resets the checked items as indicated on the **Rest** dialog window (Figure 4). This function is also available from the **Actions** menu.

### Connect/Disconnect

The **Connect/Disconnect** button is used to connect or disconnect the software from the EV kit, which connects to a PC through its USB CONTROL (J1) port or a TCP connection. The button either displays **Connect** or **Disconnect**, depending on the current state of the EV kit connection.

When the button displays **Connect**, it indicates that the software is not connected to the EV kit. Pressing the button initiates the connection sequence. When using a TCP connection, ensure that it has been set up in the software before pressing **Connect**. The TCP connection is configured from the **TCP Configuration Setup** dialog, which is accessed by selecting **Options | Connect Options | TCP** from the **Menu** bar.

When the button displays **Disconnect**, it indicates that the software is connected to the EV kit. Pressing the button initiates the disconnect sequence.

### Status Panel

The MAX98091 **Status** panel, located on the left side of the software main window, displays the state of the six status bits (register 0x01), the shutdown bit (register 0x45), and the state of the MAX98091 hardware IRQ pin. The color of a **Status** label indicates whether it is asserted or not. When asserted, the label is teal colored and when not asserted, the label is light gray.

**Note:** A status bit's interrupt must be enabled in order for the status bit to get updated in the Status register. The interrupts are enabled from the **Interrupts** block.

### Quick Setup Tab

The **Quick Setup** tab provides controls for configuring the quick setup registers (0x04–0x0B). These quick setup registers are write-only and function like pushbuttons. Refer to the *Quick Setup Configuration* section in the MAX98091 IC data sheet for additional details.

As the first four steps are completed, the section at the bottom of **Step 5** is updated. Checkmarks indicate that the step is complete and the **Reg:** and **Bit-** labels indicate which quick setup register and bit are programmed.

For simplicity, this tab is divided into five steps as shown in Figure 5. The first three steps configure the **System**

**Clock, Sample Rate, Mode, and Format.** The fourth step configures the audio **Input** and **Output** (I/O) signal path. As I/O selections are made, a corresponding image is shown in the **Configuration** group box, providing a visual representation of the selected path. When a valid I/O path is selected, **Step 4** is complete. To clear the input and output selections, press the **Clear** button.

Once all four checkmarks are visible, press the **Configure** button to program the device. If an invalid I/O path is selected, the software reports “**Not a valid I/O configuration**” and the I/O selections are cleared.

### Block Diagram Tab

The MAX98091 software uses a block diagram to facilitate the programming of the MAX98091 as well as provide a visual representation of the device's functions and current configuration. The controls for a given function(s) are grouped on the same dialog window, which is opened by clicking on the associated block image. The blocks that are within the dotted border are related to the MAX98091 device and the blocks outside the dotted border are for the associated support circuitry.

There are two types of blocks in the block diagram and they are distinguished by the mouse cursor image. The mouse cursor changes to a hand when over an active block and changes to an up-arrow when over a toggle block. An active block opens a dialog window, containing controls for configuring the device. A toggle block does not open a dialog window, but toggles a specific setting when clicked.

The color of the blocks changes, depending on the enabled state of the function(s) it controls. A disabled block is grey and an enabled block is teal. Figure 6 shows the block diagram with the MAX98091 configured for USB audio input and headphone output. **Note:** A disabled/enabled block does not necessarily indicate that its associated audio path is disabled/enabled.

### S/PDIF and USB

The S/PDIF and USB blocks are outside the dotted border and thus not related to the MAX98091 device. These blocks represent the stereo digital audio transceiver (U201) and the USB stereo audio DAC (U200) that are designed onto the EV kit. These blocks are used to enable the associated circuits, but also include controls that automatically configure the MAX98091 to work with the enabled audio device.

**Quick Setup** | Block Diagram | Control Registers | EQ Registers | BQ Registers

**Step-1** System Clock  
 256 Kfs  
 11.2896MHz  
 12MHz  
 12.288MHz  
 13MHz  
 19.2MHz  
 26MHz

**Step-2** Sample Rate  
 8kHz  
 16kHz  
 32kHz  
 44.1kHz  
 48kHz  
 96kHz

**Step-3** Mode  
 Master  
 Slave  
 Format  
 Right Justified  
 Left Justified  
 I2S

**Step-4** Input  
 IN1 IN2 IN3 IN4 MIC1 MIC2 DIGITAL AUDIO IN5 IN6  
 Direct Single Ended Differential MIC1 (1,2) MIC2 (3,4) DAI Direct Single Ended Differential

**Step-4** Output  
 MODE LINE BTL LINE/Rcvr Left Right Speaker Headphone DAI  
 Left Right Left Right

**Configuration**  
 DIGITAL AUDIO L R  
 Clear Configure

Progress: Reg: 0x04 Bit-4  Step-1; Reg: 0x05 Bit-4  Step-2; Reg: 0x06 Bit-2  Step-3; Reg: 0x07 Bit-7  Step-4

Figure 5. Quick Start Tab

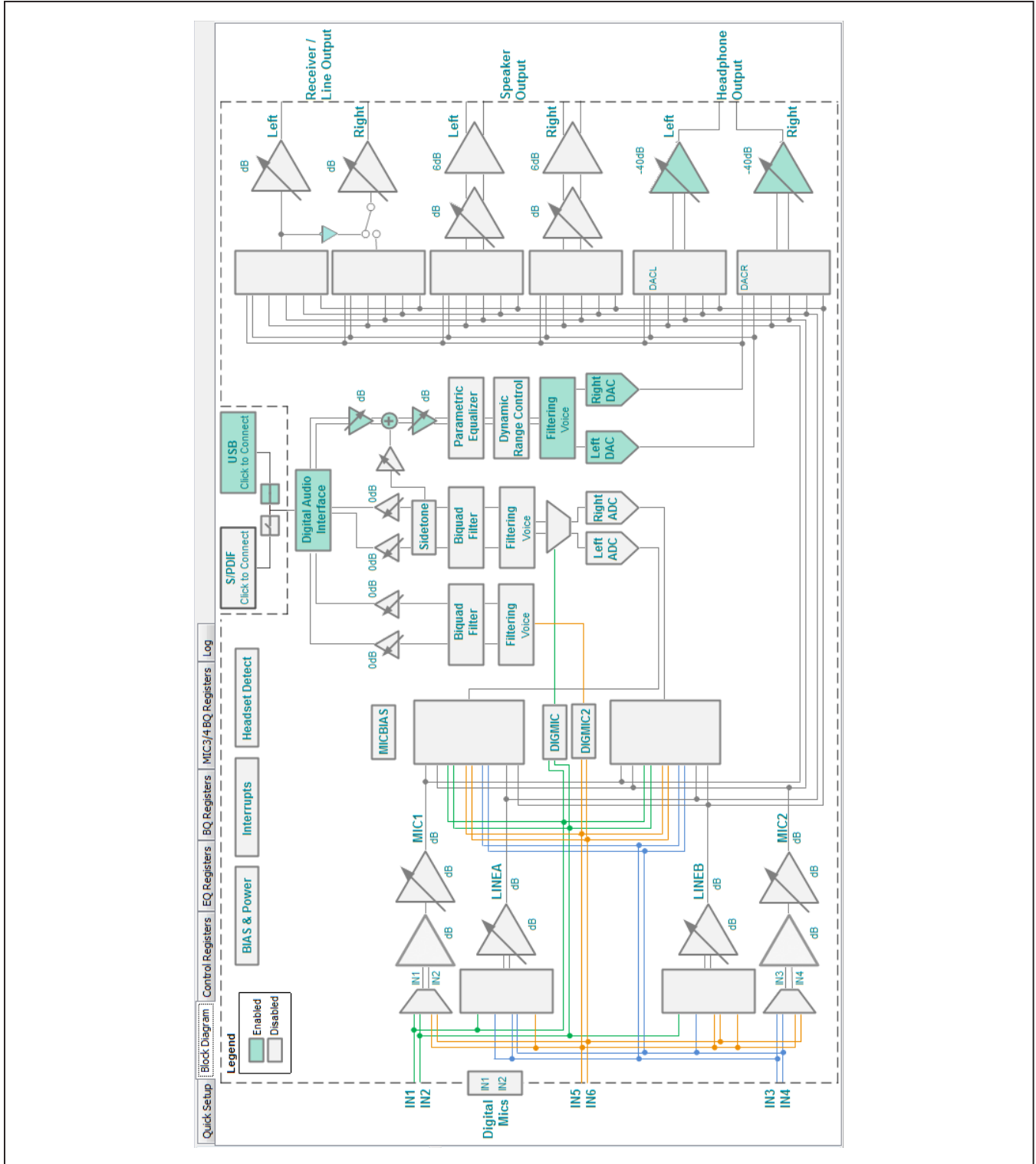

Figure 6. MAX98091 Software Block Diagram



The S/PDIF and USB audio devices are connected to the MAX98091 I<sup>2</sup>S bus through analog switches (U8–U10), which are controlled through the MAX98091 software. These switches are automatically configured once the S/PDIF or USB block is enabled, but they can be toggled by clicking on the switch blocks.

### Dialog Windows

Dialog windows are associated with specific blocks in the block diagram and they contain the controls for configuring the registers that are associated with that particular block of the MAX98091 device. The highlighted blocks in [Figure 7](#) are the blocks that share a dialog window. In addition, the blocks that are outlined can have their dialog windows synchronized to each other. This dialog sync feature is a software feature and is enabled by selecting the **Sync Right and Left** checkbox in the dialog window. When enabled, the software programs the same user configurations to both the left and right output channels.

A dialog window is opened by clicking on a diagram block. [Figure 8](#) shows the typical GUI controls that are found on dialog windows and [Figure 9](#) shows the biquad filter dialog. When a control's state is changed, it results in the programming of the associated device register(s).

The biquad dialog uses the same types of controls as other dialogs, but it also provides a plot of the filter's amplitude and phase. This provides a visual representation of the programmed coefficients as well as some insight into the filter's behavior. The only two blocks that use this type of biquad filter dialog are the **Biquad Filter** and **Parametric Equalizer** blocks.

The filter dialog shown in [Figure 9](#) is for the 7-band parametric equalizer as can be seen by the seven available filters. Each filter can be individually programmed, and when selected, appears as yellow lines on the plots. A sum of all the enabled filters can be displayed by selecting the **Show Cascade** checkbox. The cascaded response appears as a blue line on the plots. The **Biquad Filter** dialog window is similar to that shown in [Figure 9](#), except that it is only a single biquad filter.

### Registers Tabs

The MAX98091 software has four device register tabs: **Control Registers**, **EQ Registers**, **BQ Registers**, and **MIC3/4 BQ Registers**. These register tabs display the device's registers in a typical register map format. Each of the register tabs provides two methods for configuring the device. As an example, [Figure 10](#) shows the register tab elements of register 0x25.

The first configuration method involves clicking on the register's bit labels. A greyed-out bit label indicates that the bit is currently set low. A **bold** bit label indicates that the bit is currently set high. Clicking on a bit toggles its state and result in a write to that register. This action also updates the value displayed in the register's **Edit** box, located to the right of the bit labels. **Note:** Read-only bits cannot be clicked/toggled and are only meant to display the register's current state. These read-only bits are updated by performing a read all operation.

The second configuration method involves entering a hexadecimal value in the register's associated **Edit** box and then pressing the Enter key. The software automatically configures the device register once the Enter key is pressed. This method also updates the state of the bit labels to reflect the value shown in the **Edit** box.

### Control Registers

The **Control Registers** tab provides access to most of the device's control registers and all of its status registers. The range of registers accessible from this tab is from register address 0x00–0x45 and the revision ID register (0xFF).

The **Write All (F8)** button writes to all the writeable registers on the **Control Registers** tab. It also writes to all the S/PDIF transceiver registers and updates the configurable GPIOs.

Register changes made through this tab are reflected on the **Block Diagram** tab. As such, the **Control Registers** tab and the **Block Diagram** tab are always in sync. However, register changes made through the **Control Registers** tab are not automatically reflected on open dialog windows. To have an open dialog window updated, close then reopen the dialog window.

### Equalizer (EQ) Registers

The main use of the **EQ Registers** tab is to provide access to the raw data contained in the EQ registers (0x46–0xAE). The preferred method for configuring the device's equalizer is through the **7-Band Parametric Equalizer** dialog window ([Figure 9](#)).

The registers on this tab are grouped into seven bands (Band 1 through Band 7) and each band consists of fifteen registers. These fifteen registers are then divided into five coefficients (B0\_, B1\_, B2\_, A1\_, and A2\_). The coefficients are configured by clicking the register bit labels or by entering a 24-bit hex-formatted value in its **Edit** box.

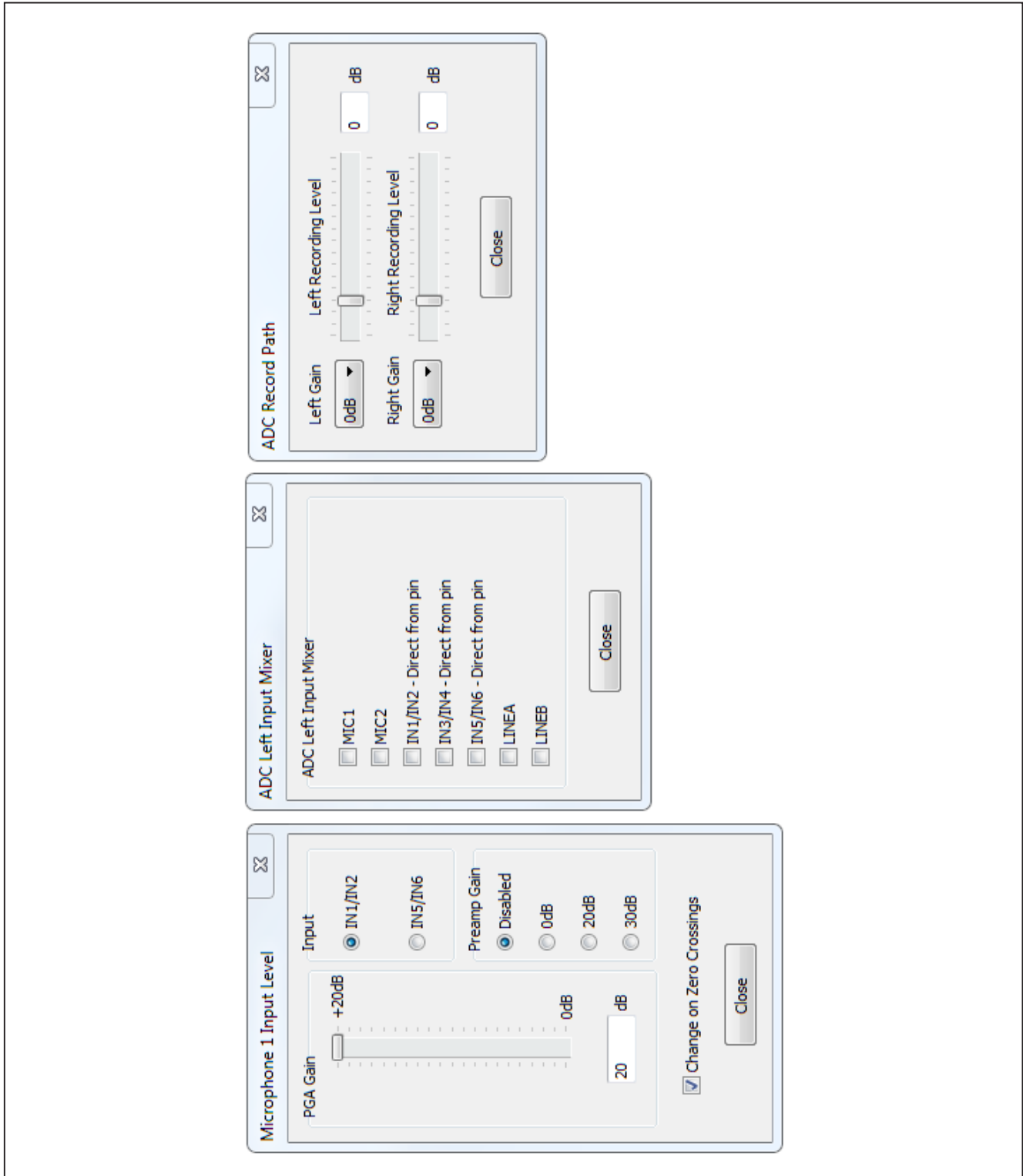

Figure 7. Dialog Windows

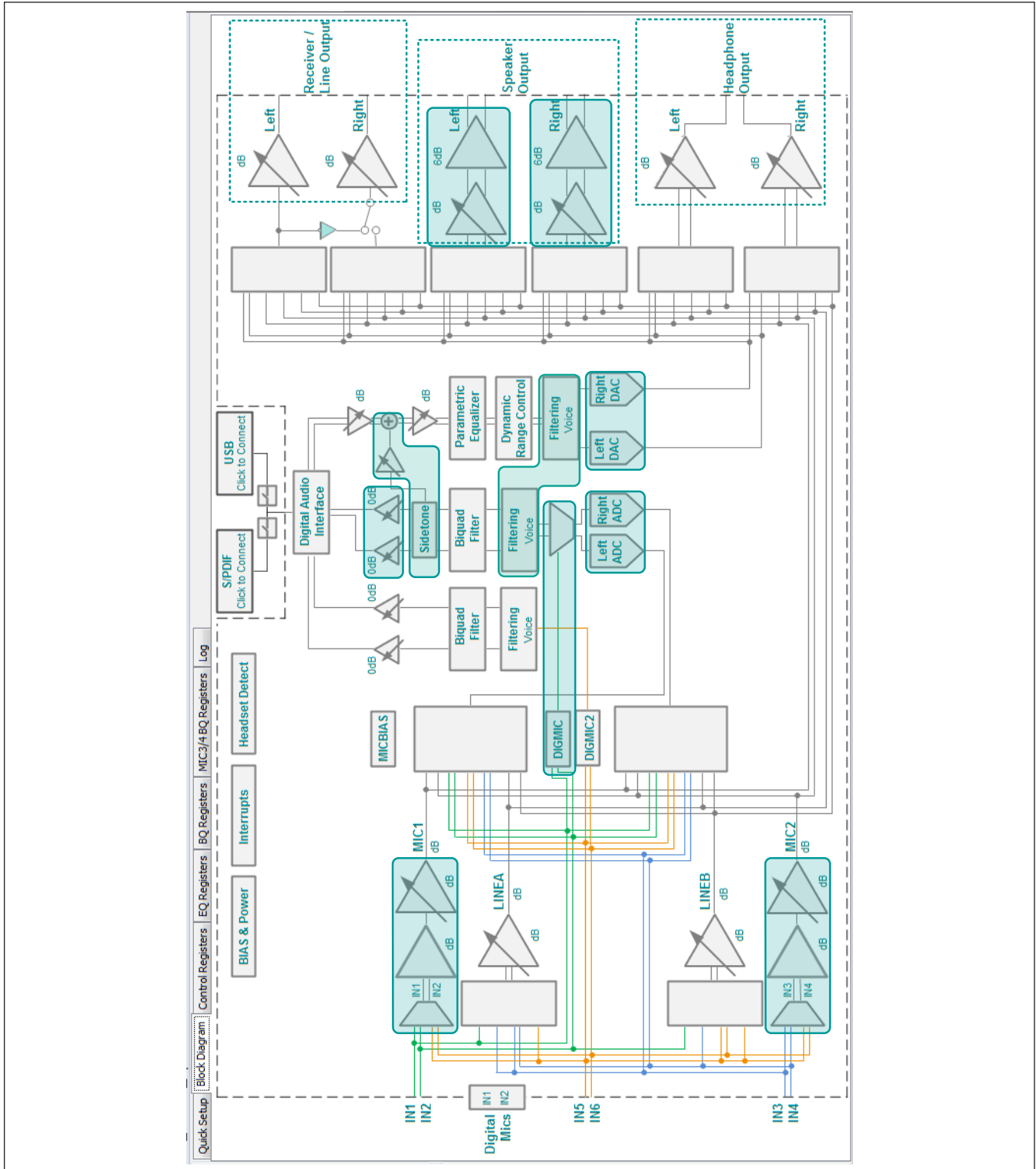

Figure 8. Diagram Blocks with Shared and/or Synchronized Dialog Windows

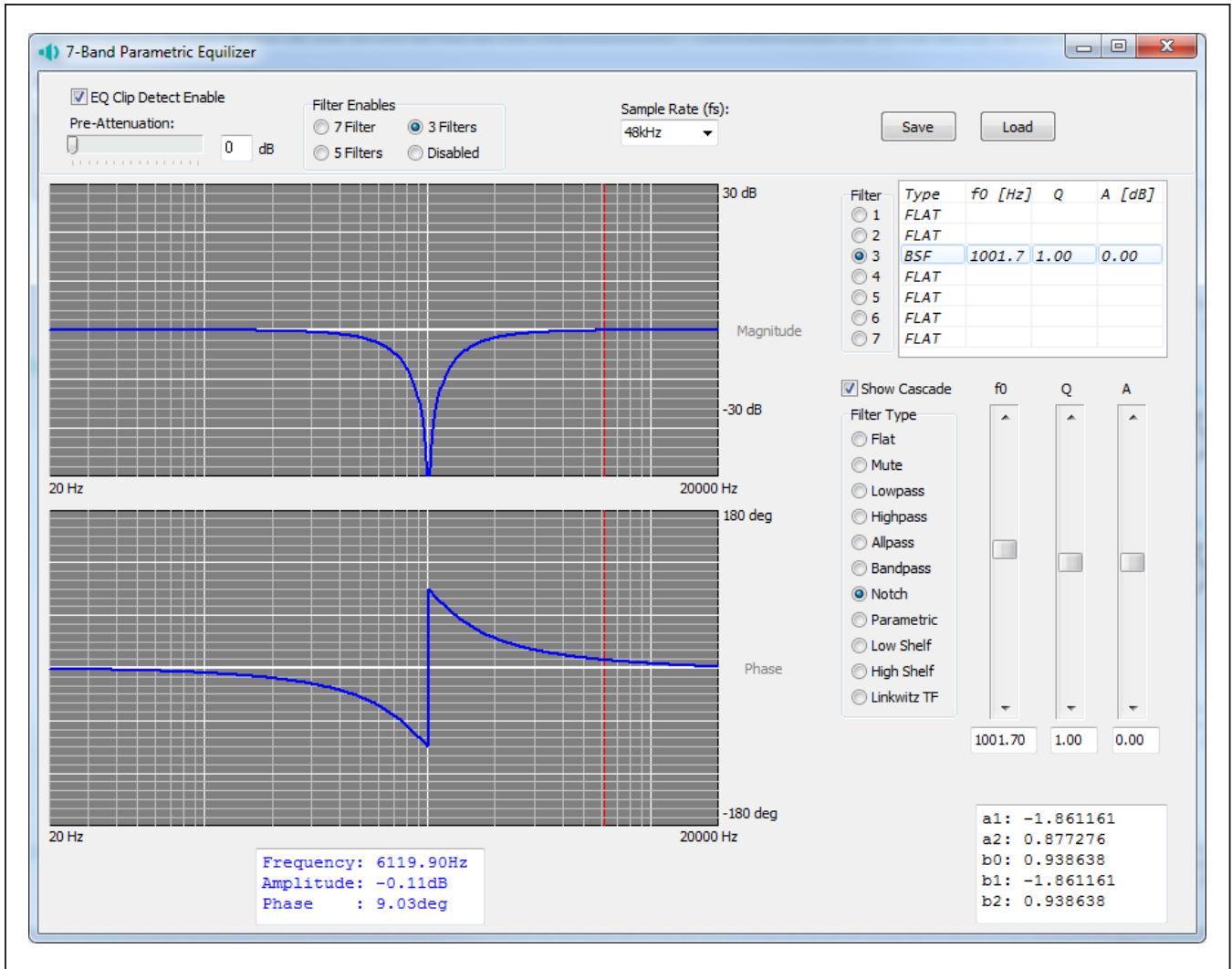

Figure 9. Biquad Filter Dialog Window

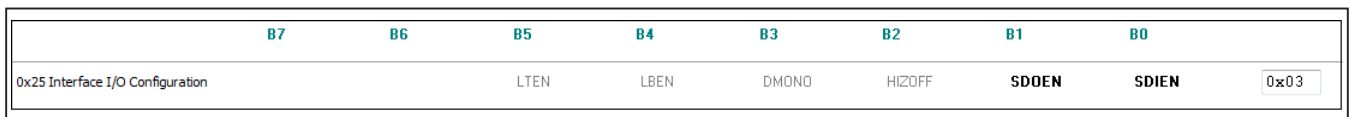

Figure 10. Register Tab Elements

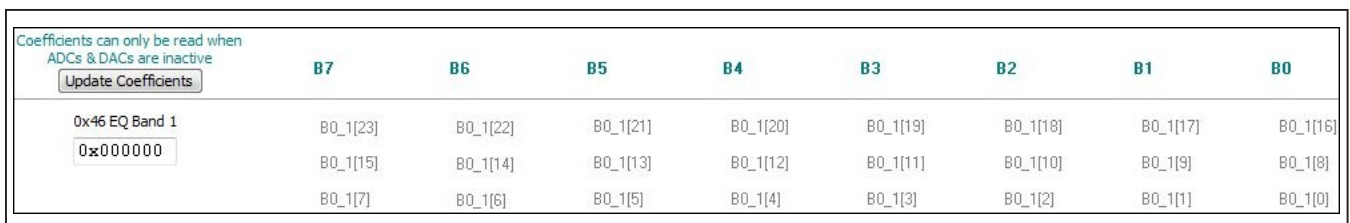

Figure 11. Coefficient (B0) of EQ Band 1

The **Update Coefficients** button updates the EQ register map to reflect any changes that were made through the **7-Band Parametric Equalizer** dialog window.

**Note:** Coefficient changes made through this **EQ Registers** tab are not reflected on the **Block Diagram** tab or the **7-Band Parametric Equalizer** dialog window.

### Biquad (BQ) Registers

The main use of the **BQ Registers** and **MIC3/4 BQ Registers** tab is to provide access to the raw data contained in the 15 BQ registers (0xAF–0xBD) and 15 MIC3/4 BQ registers (0xC3–0xD1), respectively. The preferred method for configuring the device's biquad filter is through the **Biquad Filter** dialog window.

The BQ registers are divided into five coefficients (B0, B1, B2, A1, A2) that are configured by clicking the register bit labels or entering a 24-bit hex-formatted value in the coefficient's **Edit** box.

The **Update Coefficients** button updates the tab to reflect any changes that were made through the **Biquad Filter** dialog window.

**Note:** Coefficient changes made through the **BQ Registers** tabs are not reflected on the **Block Diagram** tab or the **Biquad Filter** dialog window.

### Menu Bar

All the **Menu** bar items are described in [Table 1](#). Additional information on a few of the menu items is provided in the following sections.

#### File

The software's save and load features are accessed from the **File** menu item. The save feature saves the data currently displayed on the **Control Registers** tab and **S/PDIF Transceiver** tab. The current state of the configurable GPIO pins is also saved to the configuration file. The data from the **EQ Registers** and **BQ Registers** tabs is saved if the filters are enabled.

A configuration file's main purpose is to capture the current state of the MAX98091's registers, as displayed on the register tabs. This feature makes it easy to program a device to a saved/known state and allows for the sharing of configuration files between users. The file and save features can still be used when an EV kit is not connected. This allows configuration files to be created and opened without the hardware and further contributes

to the sharing of configuration files. To facilitate file usage, use descriptive file names when saving configuration files.

Since the configuration file is automatically generated by the software, it is not meant to be manually formatted and doing so can cause file loading issues. To open a configuration file for viewing, use a plain text editor.

Select **File | Save Settings Ctrl+S** to create a configuration file. Data is saved as tab-delimited values and the file is saved with a .98091 extension.

To load a saved configuration file, select **File | Load Settings Ctrl+O**. Only writeable registers are programmed with data from the loaded configuration file.

#### Connect Options

The **Connect Options** item is accessed from the **Options** menu. This menu item provides two options for connecting the EV kit to the MAX98091 software. The simplest method (**MAXQ USB**) uses a standard male-to-male USB cable (A to mini-B) connection. A local PC, running the MAX98091 software, connects to the USB CONTROL port (J1) on the EV kit. This method utilizes the on-board MAXQ2000 microcontroller circuitry to communicate with the MAX98091 I<sup>2</sup>C-capable device.

The **TCP** option is used to set up an internet connection between the EV kit and the software. To use this feature, additional hardware and software (not provided) are required. The additional tools would function as the communication medium between the ethernet connection and the MAX98091's I<sup>2</sup>C bus. When using this option, the USB CONTROL port (J1) on the EV kit still needs to be powered to supply the on-board LDOs.

### Detailed Hardware Description

The MAX98091 EV kit evaluates the TQFN package version of the MAX98091 audio codec and provides access to all analog and digital inputs/outputs on the device. The EV kit also includes USB-powered linear-dropout (LDO) regulators that allow the EV kit to be evaluated with a single external supply (+2.8V to +5.5V).

Integrated into the EV kit design are a stereo digital audio transceiver (U201) and a stereo audio DAC with USB interface (U200). The digital audio transceiver provides audio input and output through the on-board TOSLINK (SPDIFOUT and SPDIFIN) connectors and the USB audio DAC allows for audio input from the USB AUDIO port (J2).

Table 1. Menu Bar Items

MENU ITEM	DESCRIPTION
<b>FILE</b>	
Load Settings    Ctrl+O	Loads a configuration file (as saved by the <b>Save Settings</b> option).
Save Settings    Ctrl+S	Saves a configuration file containing the current device settings.
Exit	Closes the MAX98091 software.
<b>VIEW</b>	
Show S/PDIF Transceiver Registers	Toggles the visibility of the <b>S/PDIF Transceiver</b> register tab, allowing for more control of the on-board S/PDIF transceiver (U201).
<b>OPTIONS</b>	
Autoconnect	When selected, the software checks the connection status of the MAXQ2000 interface and the MAX98091 device approximately every second. If not connected, the software attempts to establish a connection.
Autoread Status	When selected, the device's status registers read approximately every second. The <b>Status</b> panel and <b>Control Registers</b> tab are refreshed after each read.
Autoshutdown for Register Writes	When selected, the software ensures that the MAX98091 is in shutdown before writing to certain registers. Refer to Table 90 of the MAX98091 data sheet for the registers that should only be programmed while the device is in shutdown.
<b>I<sup>2</sup>C CLOCK SPEED</b>	
100kHz	Configures the clock speed of the I <sup>2</sup> C interface.
400kHz	
Configure MCLK Routing	Opens the <b>MCLK Routing</b> dialog window that is used to select a clock source for the MAX98091 master clock (MCLK) input. In order for this clock to drive the MAX98091, a shunt must be placed on pins 1–4 of header JU14.
Connect Options	Sets the interface method between the EV kit and MAX98091 software.
Cmod USB	The MAX98091 EV kit interfaces to a local PC through its USB Control (J1) port.
TCP	The MAX98091 EV kit interfaces to a remote PC through a TCP connection. Additional hardware setup required.
<b>ACTIONS</b>	
Read All Registers F4	Reads all MAX98091 registers and updates the GUI. Also reads all of the S/PDIF transceiver (U201) registers.
Write All Registers F8	Writes the data from the <b>Edit</b> boxes, on the <b>Control Registers</b> tab, to the MAX98091 device and updates the GUI. Also writes to the S/PDIF transceiver (U201) registers and updates all configurable GPIO pins.
Reset All Registers F12	Resets the device according to the check box selections on the <b>Reset</b> dialog window.
<b>HELP</b>	
About	Pop-up window that provides information about the software.

In addition, the EV kit includes a MAXQ2000 microcontroller that facilitates evaluation by providing I<sup>2</sup>C, SPI, and GPIO interfaces, allowing the MAX98091 software to communicate with the devices on the EV kit.

### Power Supplies

The EV kit requires a single 2.8V to 5.5V external supply (SPKVDD) to operate. All other MAX98091 supply inputs are powered from the J1 USB port. Jumpers JU1–JU4 (see [Table 2](#)) allow all MAX98091 supply inputs to be disconnected from USB power and connected to external supplies. In addition, jumpers JU1 and JU2 are used to configure the on-board voltage connected to DVDD and DVDDIO, respectively. See [Table 2](#) for jumper JU1–JU4 configuration options.

To perform supply current and power-consumption measurements, use external supplies to power the MAX98091 supply inputs: HPVDD, AVDD, DVDD, and DVDDIO.

### Jumper Selection

The EV kit includes 25 jumpers to adjust various hardware configuration options. [Table 2](#) describes all the jumpers available on the EV kit.

### Master Clock (MCLK) Selection

Jumper JU12 selects which master clock (MCLK) source drives the MAX98091 device. The available clock configurations are listed in [Table 3](#). When streaming audio through the on-board USB AUDIO port or S/PDIF connectors, the EV kit software automatically configures the U8 and U9 switches to route the appropriate clock signal to the MAX98091 MCLK input.

If an external audio source is used, choose either the on-board 13MHz oscillator or an external clock. To connect an external clock, remove the shunt from JU14 and connect the clock to pin 1.

### I<sup>2</sup>S Audio I/O

The EV kit provides three methods for evaluating the MAX98091's digital audio interface (DAI). The first method is through the I<sup>2</sup>S header (JU15). This method provides the most direct connection to the MAX98091's DAI.

The two other methods involve streaming audio onto or off the EV kit. The USB AUDIO port (J2) is used to stream audio onto the EV kit. The SPDIFIN and SPDIFOUT optical connectors are used to stream audio onto or off the EV kit, respectively.

The USB and S/PDIF digital audio signals are switched onto the PCM bus through switches U10 and U11. The switches are automatically configured by the evaluation kit software, depending on which path has been enabled (**USB** or **S/PDIF**).

**Note:** All PCM digital audio is routed through the I<sup>2</sup>S header before routing to the MAX98091's DAI. This is true for the USB AUDIO input as well as for the S/PDIF I/O. See [Figure 12](#).

### Digital Audio Interface Header (JU15)

Header JU15 provides access to the MAX98091 digital audio interface (DAI). See [Table 4](#) for individual pin descriptions. Follow the steps below to configure JU15:

#### Direct connection of PCM digital audio:

- 1) Remove the shunts from JU15 (place shunts on Position 1 for safekeeping).
- 2) Connect the PCM signals/grounds to the corresponding position 2 (center) and position 3 (right) pins of JU15.

#### USB Audio Input or SPDIF I/O:

- 1) Install the four shunts between position 2 and position 3 of JU15.
- 2) For audio input, connect an audio output device to the USB AUDIO or SPDIFIN connector.
- 3) For audio output, connect an audio input device to the SPDIFOUT connector.

**Table 2. Jumper Configuration**

HEADER	SHUNT POSITION	DESCRIPTION
JU1	1-2*	DVDD connected to +1.2V
	2-3	DVDD connected to +1.8V
	Open	DVDD externally supplied
JU2	1-2	DVDDIO connected to +3.3V
	2-3*	DVDDIO connected to +1.8V
	Open	DVDDIO externally supplied
JU3	Installed*	AVDD connected to +1.8V
	Open	AVDD externally supplied
JU4	Installed*	HPVDD connected to +1.8V
	Open	HPVDD externally supplied
JU5	Installed	Connects JACKSNS to headphone jack, HP, for jack detection; ensure that a shunt is installed on JU27/JU6 or JU28/JU22 for proper jack detection.
	Open*	Disconnects JACKSNS from the headphone jack, HP
JU6	Installed	Connects MICBIAS to the IN1 input through a 2.2k $\Omega$ resistor (for microphone input)
	Open*	Disconnects MICBIAS from the IN1 input
JU7	Installed	Connects MICBIAS to the IN3 input through a 2.2k $\Omega$ resistor (for microphone input)
	Open*	Disconnects MICBIAS from the IN3 input
JU8	Installed	Connects IN2 directly to ground for single-ended operation
	Open*	Allows for differential operation
JU9	Installed	Connects IN2 to ground through a 2.2k $\Omega$ resistor (used when IN1 is mic biased)
	Open*	Disconnects IN2 from ground
JU10	Installed	Connects IN4 directly to ground for single-ended operation
	Open*	Allows for differential operation
JU11	Installed	Connects IN4 to ground through a 2.2k $\Omega$ resistor (used when IN3 is mic biased)
	Open*	Disconnects IN4 from ground
JU14	—	See <a href="#">Table 3</a>
JU15	—	See <a href="#">Table 4</a>
JU16	2-3, 5-6*	Connects the on-board I <sup>2</sup> C master to MAX98091
	Open	Allows external I <sup>2</sup> C control of MAX98091
JU17	Installed	Removes AC-coupling capacitor, C4, from LOU <sub>TL</sub> line output
	Open*	Adds AC-coupling capacitor, C4, to LOU <sub>TL</sub> line output
JU18	Installed	Removes AC-coupling capacitor, C5, from LOU <sub>TR</sub> line output
	Open*	Adds AC-coupling capacitor, C5, to LOU <sub>TR</sub> line output
JU19	Installed	Connects MICBIAS to IN5 through a Schottky diode and 2.2k $\Omega$ resistor
	Open*	Disconnects MICBIAS from IN5
JU20	Installed	Connects IN5 to the headphone jack, HP (for microphone input)
	Open*	Disconnects IN5 from the headphone jack, HP



**Table 2. Jumper Configuration (continued)**

HEADER	SHUNT POSITION	DESCRIPTION
JU21	—	See <a href="#">Table 8</a> .
JU22	Installed	Connects MICBIAS to IN5 through a 2.2kΩ resistor
	Open*	Disconnects MICBIAS from IN5
JU23	Installed	Connects IN6 to ground through a 2.2kΩ resistor (when IN5 is microphone biased)
	Open*	Disconnects IN6 from ground
JU24	Installed	Connects IN6 directly to ground for single-ended operation
	Open*	Allows for differential operation
JU27	Installed	Connects IN1 to the headphone jack, HP (for microphone input)
	Open*	Disconnects IN1 from the headphone jack, HP
JU100	Installed*	Connects the MAX98091 interrupt output ( $\overline{IRQ}$ ) to the on-board microcontroller
	Open	Disconnects the MAX98091 interrupt output ( $\overline{IRQ}$ ) from the on-board microcontroller

\*Default position.

**Table 3. Master Clock Source Configuration (JU14)**

SHUNT POSITION	CLOCK SOURCE
1-2	Disabled
1-3	13MHz oscillator
1-4*	Software-selected clock source

\*Default position.

**Table 4. DAI Header (JU15)**

JU16		
POSITION 1 (LEFT)	POSITION 2 (CENTER)	POSITION 3 (RIGHT)
GND	CODEC_BCLK	I2S_BCLK
GND	CODEC_LRCLK	I2S_LRCLK
GND	CODEC_SDIN	I2S_DAC
GND	CODEC_SDOUT	I2S_ADC

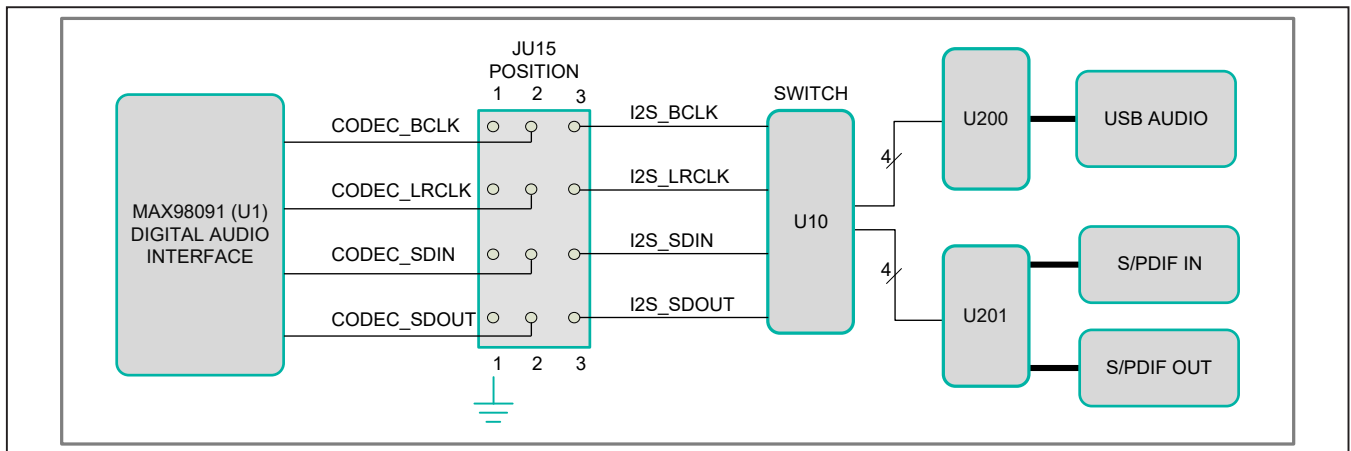

Figure 12. I<sup>2</sup>S Routing

**S/PDIF Transceiver**

The S/PDIF transceiver (U201) serves as a format converter between I<sup>2</sup>S and S/PDIF. Use this device to send and receive digital audio over the optical connectors (SPDIFIN, SPDIFOUT).

When receiving S/PDIF data, the transceiver outputs a recovered master clock that is exactly 256 x f<sub>S</sub>, where f<sub>S</sub> is the sample rate. This clock signal can be used to clock the MAX98091.

When transmitting S/PDIF data, the transceiver requires a master clock input and if data is also being received, it uses the data to generate its own master clock.

If S/PDIF data is not being received, the transceiver generates a master clock based on the LRCLK signal being output by the MAX98091. For proper transmit-only operation, the S/PDIF transceiver must be configured in master mode.

The S/PDIF transceiver is controlled through the SPI interface of the on-board MAXQ2000 microcontroller. See the [Control Interface](#) section.

**USB Audio**

The audio DAC with USB interface (U200) accepts an audio stream from a PC, connected to the USB AUDIO port (J2), and converts it to I<sup>2</sup>S data. The USB audio DAC generates a master clock signal that can be used to clock the MAX98091. The clock signal is 256 x f<sub>S</sub>.

The USB audio DAC supports standard class drivers that are included with most operating systems. As a result, no

drivers are required for this device, and it appears as a sound card in the PC. This allows for audio playback from the PC through the MAX98091 audio codec.

**Analog Inputs**

The MAX98091 analog input pairs (IN1/IN2, IN3/IN4, and IN5/IN6) can be configured for microphone input, single-ended input, or differential input. These input connections are made through the provided RCA connectors or PCB pads (IN1–IN6). In addition, the IN1/IN2 and IN5/IN6 device inputs can be connected to the 3.5mm audio jack (HP) for single-ended microphone input from a headset. [Table 5](#) lists the configuration headers associated with each input pair. See the specific input sections for configuration details.

**Single-Ended and Differential Inputs**

The three analog input pairs are configured for single-ended or differential line input by configuring the associated input headers (as listed in [Table 6](#)). For single-ended inputs, the input header configuration is independent of the input type. For differential inputs, the header configuration is different for microphone inputs powered by the MAX98091 MICBIAS output.

**Analog Microphone**

When using the analog input pairs for microphone input, the MAX98091 microphone bias (MICBIAS) output can be used to power the connected microphone. The MICBIAS output is connected to the IN1, IN3, or IN5 input through the input’s associated MICBIAS header.

**Table 5. Analog Input Headers**

INPUT PAIR	SINGLE-ENDED/ DIFFERENTIAL HEADER	DIFFERENTIAL MICROPHONE HEADER	MICBIAS HEADER
IN1/IN2*	JU8	JU9	JU6
IN3/IN4	JU10	JU11	JU7
IN5/IN6*	JU24	JU23	JU22 or JU19

\*The microphone input from the HP headset is routed to IN1 and IN5 of these input pairs.

**Table 6. Analog Input Header Configuration**

INPUT	SINGLE-ENDED	DIFFERENTIAL	DIFFERENTIAL MICROPHONE (W/MICBIAS)
IN1/IN2	JU8 = On	JU8 = Off JU9 = Off	JU8 = Off JU9 = On
IN3/IN4	JU10 = On	JU10 = Off JU11 = Off	JU10 = Off JU11 = On
IN5/IN6	JU24 = On	JU24 = Off JU23 = Off	JU24 = Off JU23 = On

When evaluating with two analog microphones, and jack detection is required, the IN5 input needs to be connected to MICBIAS through jumper JU19. See [Table 7](#).

**Digital Microphone**

The EV kit includes on-board digital microphones (U2 and U3) for evaluation of the MAX98091’s digital microphone interface. The digital microphone interface is enabled and configured through the software.

Install shunts on columns 2 and 3 (DUT and SRC) of jumper JU21 ([Table 8](#)) to connect the digital microphone(s) to the circuit. Use the **Digital Mics** block in the evaluation software to select which inputs (IN1/I2 or IN5/IN6) are connected to the digital microphones and use the **DIGMIC** and **DIGMIC2** blocks to enable the MAX98091 digital microphone inputs. Refer to the MAX98091 IC data sheet for additional details.

**Jack Detection**

The MAX98091’s flexible, software-configurable jack-detection interface is used to detect the presence or absence of a headphone/headset connected to the HP jack. To provide jack detection on the HP jack, install a shunt on header JU5.

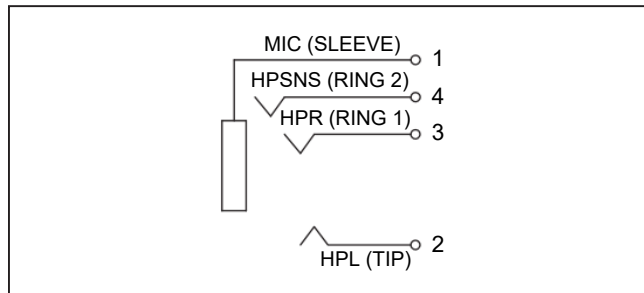

Figure 13. Headphone Jack

**Analog Outputs**

The EV kit provides connections for each of the three analog outputs. [Table 9](#) lists the outputs and their available connections.

**Headphone**

The MAX98091 stereo headphone output (HPR/HPL) is routed to the on-board 3.5mm audio jack (HP), as shown in [Figure 13](#). The HP jack also allows for a headset connection, with the microphone input (MIC) connected to either IN1 or IN5. See the [Analog Inputs](#) section for input configuration options.

**Stereo Class D Speaker Amplifier**

The MAX98091 integrates a filterless Class D stereo amplifier. In systems with short speaker traces, the stereo speaker outputs (SPKLP/SPKLN and SPKRP/SPKRN test points) can be connected directly to the speaker loads. Although this amplifier is designed to operate completely filterless, the EV kit does provide stuffing options for two types of output filters.

When long speaker cables are used, a ferrite bead plus capacitor filter can be installed to prevent excessive EMI radiation. Although it is best to choose filter components based on EMI test results, the combination of a 680pF capacitor (C48–C51) with the Murata BLM18SG331TN1 ferrite bead (FB1–FB4) generally works well. With this configuration, connect the speaker loads to the SPKLP/SPKLN and SPKRP/SPKRN test points.

To allow analysis of the audio output with an oscilloscope, or an analyzer not designed to accept Class D switching waveforms, populate L1–L4 with the included 22µH inductors and make connections, to external equipment or speakers, at FSPKLP/FSPKLN and FSPKRP/FSPKRN. The LC filter is designed to work best with an 8Ω load. Do not connect a load to the unfiltered SPKLP/SPKLN and SPKRP/SPKRN outputs when L1–L4 are installed.

**Table 7. MICBIAS Connection**

MICROPHONE CONNECTION	MICBIAS CONNECTED	MICBIAS DISCONNECTED
IN1	JU6 = On	JU6 = Off
IN3	JU7 = On	JU7 = Off
IN5	JU22 = On JU19 = Off	JU22 = Off JU19 = Off
IN5*	JU22 = Off JU19 = On	JU22 = Off JU19 = Off

\*Configuration for two analog microphones, requiring jack detection.

**Table 8. Digital Microphone Configuration (JU21)**

SHUNT POSITION	CONNECTIONS
8-9, 11-12	Digital microphones (U2, U3) connected to the MAX98091 digital microphone 1 interface (IN1/DMD1 and IN2/DMC1).
2-3, 5-6	Digital microphones (U2, U3) connected to the MAX98091 digital microphone 2 interface (IN5/DMD2 and IN6/DMC2).

**Table 9. Analog Outputs**

OUTPUT	CONNECTIONS
Headphone	3.5mm audio jack (HP)
Speaker	Unfiltered and filtered connection options (SPK_P/SPK_N and FSPK_P/FSPK_N)
Receiver/Line-Out	RCA connectors (LOUTL and LOUTR)

**Table 10. I<sup>2</sup>C Header (JU16)**

JU16		
POSITION 1 (LEFT)	POSITION 2 (CENTER)	POSITION 3 (RIGHT)
GND	CODEC_SCL	SCL
GND	CODEC_SDA	SDA

**Receiver/Line Output**

The MAX98091 receiver/line output can be configured either as a differential receiver/earpiece output or as a stereo single-ended line output. The receiver/line outputs are routed, through AC-coupling capacitors, to the LOUTL and LOUTR RCA connectors. The AC-coupling capacitors can be shorted (effectively removed from the signal path) by installing a shunt on JU17 and JU18.

**Control Interface**

The MAXQ2000 (U100) microcontroller circuitry is the bridge between the on-board interface-enabled devices and the EV kit software, running on a PC connected to the USB CONTROL port (J1). The EV kit utilizes the MAXQ2000’s I<sup>2</sup>C, SPI, and GPIO interfaces. See the [Detailed Description of Software](#) section for additional software details.

**I<sup>2</sup>C Interface**

The MAXQ2000’s I<sup>2</sup>C interface is routed to the MAX98091 device through jumper JU16, by installing shunts across pins 2-3 of each row (Table 10). When using an external I<sup>2</sup>C master, remove both shunts from JU16 and connect the external SDA and SCL signals to the position 2 pins of JU16. Ground connections can be made to the position 1 pins of JU16. Install pullup resistors at R15 and R16 if the external master does not include pullup resistors.

**SPI Interface**

The MAXQ2000 SPI interface is used to control the on-board S/PDIF transceiver (U201). In the MAX98091 software, go to **View | Show S/PDIF Transceiver Registers** to activate the **S/PDIF Transceiver** tab.

**GPIO Interface and Pushbutton Programmer**

Six of the MAXQ2000 general-purpose inputs/outputs (GPIOs) are used for either controlling or monitoring a specific on-board device/signal. Four of the GPIOs are used as general-purpose outputs and are automatically set/cleared based on configuration settings made through the MAX98091 software.

The other two GPIOs are used as general-purpose inputs to monitor a specific signal. The first general-purpose input ( $\overline{\text{CODEC\_IRQ}}$ ) is connected to the MAX98091 interrupt (IRQ) output. This  $\overline{\text{IRQ}}$  is monitored by the microcontroller and its state is reported in the **Status** group box on the left side of the software main window. This general-purpose input can be disconnected from the MAX98091’s IRQ output by removing the shunt from jumper JU100.

The second general-purpose input is connected to a tactile switch (SW1) to realize a pushbutton programmer. When SW1 is pressed, the MAXQ2000 microcontroller responds by transmitting a sequence of configuration settings that have been preprogrammed into its firmware. This allows the EV kit to be quickly programmed with a specific configuration, without the need for a PC running the software. By default, the pushbutton programming feature is not enabled.

**Ordering Information**

PART	TYPE
MAX98091EVKIT#TQFN	EV Kit

#Denotes RoHS compliant.

**MAX98091 (TQFN) EV Kit Bill of Materials**

REFERENCE DESIGNATOR	QTY	DNI, DNP	DESCRIPTION	MFG	MFG PART #
C1, C3, C104, C202	4		10uF ±20%, 6.3V X5R ceramic capacitor (0805)	TDK	C2012X5R0J106M
C2, C11, C12, C13, C15, C18, C24, C26, C27, C29-C35, C200, C201, C204	19		1uF ±10%, 6.3V X5R ceramic capacitor (0402)	TDK	C1005X5R0J105K
C4, C5, C23, C25, C36, C37, C115-C118	10		1uF ±10%, 6.3V X7R ceramic capacitor (0603)	Murata	GRM188R70J105K
C6, C10, C40, C41, C61-C63, C66, C203, C215, C216	11		0.1uF ±10%, 10V X7R ceramic capacitor (0402)	Kemet	C0402C104K8RAC
C8, C9	2		10pF ±5%, 50V C0G ceramic capacitor (0402)	Murata	GRM1555C1H100J
C20, C43, C211, C212	4		0.01uF ±10%, 50V X7R ceramic capacitor (0603)	Murata	GRM188R71H103K
C21, C22	2		2.2uF ±10%, 6.3V X5R ceramic capacitor (0603)	Murata	GRM188R60J225K
C28	1		2.2uF ±20%, 6.3V X5R ceramic capacitor (0402)	Taiyo Yuden	JMK105BJ225MV
C38, C39, C52-C59	10		0.22uF ±10%, 6.3V XR5 ceramic capacitor (0402)	TDK	C1005X5R0J224K
C42, C44-C51	9	Do not install, do not purchase	Ceramic capacitors (0402)		
C65	1		10uF ±20%, 6.3V X5R ceramic capacitor (0603)	Murata	GRM188R60J106M
C100, C101, C105, C107-C110, C113, C114, C209, C210	11		0.1uF ±10%, 50V X5R ceramic capacitor (0603)	TDK	C1608X5R1H104K
C102, C103, C207, C208	4		8pF ±0.5pF, 50V C0H ceramic capacitor (0402)	Taiyo Yuden	UMK105CH080DV
C106	1		33000pF ±10%, 25V X7R ceramic capacitor (0603)	Murata	GRM188R71E333K
C111, C112	2		18pF ±5%, 50V C0G ceramic capacitor (0603)	TDK	C1608C0G1H180J
C113	1	Do not install, do not purchase	0.1uF ±10%, 50V X5R ceramic capacitor (0603)		
C205, C206	2		47uF ±20%, 6.3V X5R ceramic capacitor (1206)	Murata	GRM31CR60J476M
C213	1		0.47uF ±10%, 6.3V X5R ceramic capacitor (0603)	Murata	GRM188R60J474K
C214	1		47000pF ±10%, 25V X7R ceramic capacitor (0603)	Murata	GRM188R71E473K
CPVDD, CPVSS, C1N, C1P, VCM, REF	6	Do not install, do not purchase	Test point (30-mil drill size)		
D2	1		Schottky diode (SOT23)	Rohm	RB411DT146
D100	1		LED, Yellow (0603)	Lite-On	LTST-C190YKT
D101	1		LED, Red (0603)	Lite-On	LTST-C190CKT
FB1-FB4	4		0 Ohms ±5% resistor (0603)		
FB5, FB6	2		0 Ohms ±5% resistor (0402)		
FB7-FB12	6		Ferrite bead (0402)	Murata	BLM15HD182SN1
FB100, FB200	2		Ferrite bead (0603)	Murata	BLM18PG221SN1
USB1, USB2	2		Receptacle, USB Mini B Receptacle	Hirose Electric	UX60A-MB-5ST
HP	1		Jack, Stereo Headphone 3.5MM, 4 positions	CUI Inc.	SJ-43514-SMT
IN1, IN2, IN3, IN4, IN5, IN6, LOU1L, LOU1R	8		JACK, PC MOUNT NON-SWITCHED , RED	Kobiconn	161-0096-E

**MAX98091 (TQFN) EV Kit Bill of Materials (continued)**

REFERENCE DESIGNATOR	QTY	DNI, DNP	DESCRIPTION	MFG	MFG PART #
JU1, JU2	2		3-pin header, 0.1" centers	Sullins	PEC36SAAN
JU3-JU11, JU17-JU20, JU22-JU24, JU27, JU100	18		2-pin header, 0.1" centers	Sullins	PEC36SAAN
JU14	1		4-pin header, 0.1" centers	Sullins	PEC36SAAN
JU15	1		12-pin header (3x4), 0.1" centers	Sullins	PEC36DAAN
JU16	1		6-pin header (2x3), 0.1" centers	Sullins	PEC36DAAN
JU21	1		12-pin header (4x3), 0.1" centers	Sullins	PEC36DAAN
L1-L4	4	Do not install	22uH, 1A inductors (6.2mm x 6.3mm)	Toko	A916CY-220M
L200	1		Ferrite bead, 47uH 220mA (1812)	Murata	LQH43MN470J03L
P100	1		MOSFET, -20V, -2.4A, P-Channel (SuperSOT-3)	Fairchild	FDN304P
P100	1		MOSFET, -20V, -2.4A, P-Channel (SuperSOT-3)	Fairchild	FDN304PZ
R1, R2, R9-R13, R32, R33, R38-R41, R111, R207	15		0 Ohms ±5% resistor (0402)		
R5	1		10 kOhms ±5% resistor (0402)		
R6, R15, R16, R19	4	Do not install, do not purchase	Resistor (0402)		
R14, R17, R18, R20, R29, R37	6		2.2 kOhms ±5% resistor (0402)		
R21, R22, R23, R24, R200, R201	6		22 Ohms ±5% resistor (0402)		
R100, R101, R104, R202, R204	5		1.5 kOhms ±5% resistor (0603)		
R102, R103	2		27 Ohms ±5% resistor (0603)		
R105	1		470 Ohms ±5% resistor (0603)		
R106	1	Do not install, do not purchase	2.2 kOhms ±5% resistor (0603)		
R107	1	Do not install, do not purchase	10 kOhms ±5% resistor (0603)		
R108, R110	2		220 Ohms ±5% resistor (0603)		
R109	1		1 kOhms ±5% resistor (0603)		
R203	1		1 MOhms ±5% resistor (0603)		
R205	1		47 kOhms ±5% resistor (0603)		
R206	1		402 Ohms ±1% resistor (0603)		
SPDIFOUT	1		Connector, Digital Audio Optical Transmitter	Everlight Electronics	PLT133/T9
SPDIFIIN	1		Connector, Digital Audio Optical Receiver	Everlight Electronics	PLR135/T9
SW1	1		SPST, tactile switch	Panasonic Electronic Components	EVQ-5PN04K
SW1	1		SPST, tactile switch	E-switch	TL3302AF260QJ
U1	1		Ultra-Low Power Stereo Audio Codec (48 TQFN)	MAXIM	MAX98091ETM+
U2, U3	2		Digital microphone (6 LGA)	Knowles Acoustics	SPM0423HD4H-WB

**MAX98091 (TQFN) EV Kit Bill of Materials (continued)**

REFERENCE DESIGNATOR	QTY	DNI, DNP	DESCRIPTION	MFG	MFG PART #
U2, U3	2		Digital microphone (6 LGA)	Knowles Acoustics	SPM0423HE4H-WB
U4	1		Single CMOS switch debouncer (4 SOT143)	MAXIM	MAX6816EUS+
U5	1		1.8V Low noise linear regulator (5 SOT23)	MAXIM	MAX8887EZK18+
U6	1		300mA LDO regulator (SOT23-6)	MAXIM	MAX1963AEZT120+
U7, U104	2		3.3V Low noise linear regulator (5 SC70)	MAXIM	MAX8511EXK33+
U8, U9	2		Low voltage SPDT CMOS analog switch (6 SC70-6)	MAXIM	MAX4729EXT+
U10	1		Low voltage Quad-SPDT analog switch (16 TQFN)	MAXIM	MAX4735ETE+
U11	1		Analog wwitch (10-pin uDFN)	MAXIM	MAX4906ELB+
U100	1		Microcontroller (56 TQFN)	MAXIM	MAXQ2000-RBX+
U101	1		USB to Serial UART (QFN-32)	FTDI	FT232BQ
U101	1		USB to Serial UART (QFN-32)	FTDI	FT232RQ
U102	1	Do not install, do not purchase	EEPROM, 93C46 TYPE 3-WIRE (SOIC-8)	Atmel	AT93C46EN-SH-B
U103	1		2.5V Low noise linear regulator (5 SC70)	MAXIM	MAX8511EXK25+
U200	1		USB audio CODEC (32 QFP)	TI	PCM2707PJT
U201	1		Digital audio transceiver (28 SO)	Cirrus Logic	CS8427-CSZ
Y1	1		13Mhz Clock Oscillator (2.5mm x 2.0mm)	ECS Inc	ECS-2033-130-BN
Y100	1		6MHz crystal	Hong Kong X'tals	SSL60000N1HK188F0-0
Y101	1		CRYSTAL, 16MHz (3.2mm x 2.5mm)	Kyocera	CX3225SB16000D0FLJZZ
Y200	1		CRYSTAL, 12MHz (3.2mm x 2.5mm)	Kyocera	CX3225SB12000D0FLJZZ
BCLK, LRCLK, SDIN, SDOUT, IRQ, MCLK	6		Test Point "Miniature" 40mil drill size (Red)	Keystone	5000
SPKLP, SPKRP, HPR, HPL	4		Test Point "Multipurpose" 63mil drill size (Red)	Keystone	5010
SPKLN, SPKRN, GND(x7), HPGND	10		Test Point "Multipurpose" 63mil drill size (Black)	Keystone	5011
+1.8V, GND	2		1-pin header	Sullins	PEC36SAAN
	31		Shunt, Shorting Jumper, 2 position, 0.1 center	Kycon	SX1100-B
IN1, IN2, IN3, IN4, IN5, IN6, JACKSENSE, RCVP/LOUTL, RCVN/LOUTR, FSPKLP, FSPKLN, FSPKRP, FSPKRN, DVDD, DVDDIO, AVDD, HPVDD, SPKVDD, GND(x6)	24		WIRE, BUSS, 20G plated solid copper 0.25 inch U-shape wire loop	Weico Wire	9020 Buss
MAX98091 TQFN Evaluation Kit	1	—	PCB: MAX98091 TQFN EVKIT	Maxim	MAX98091EVKIT#TQFN
	4		Aluminum standoff, round, 4-40 thread, 0.187" OD, 0.5"L	Keystone	2203
	4		Machine screw, philips, 4-40, 3/8" length	B&F Fastener Supply	PMSSS4400038PH

MAX98091 (TQFN) EV Kit Schematic

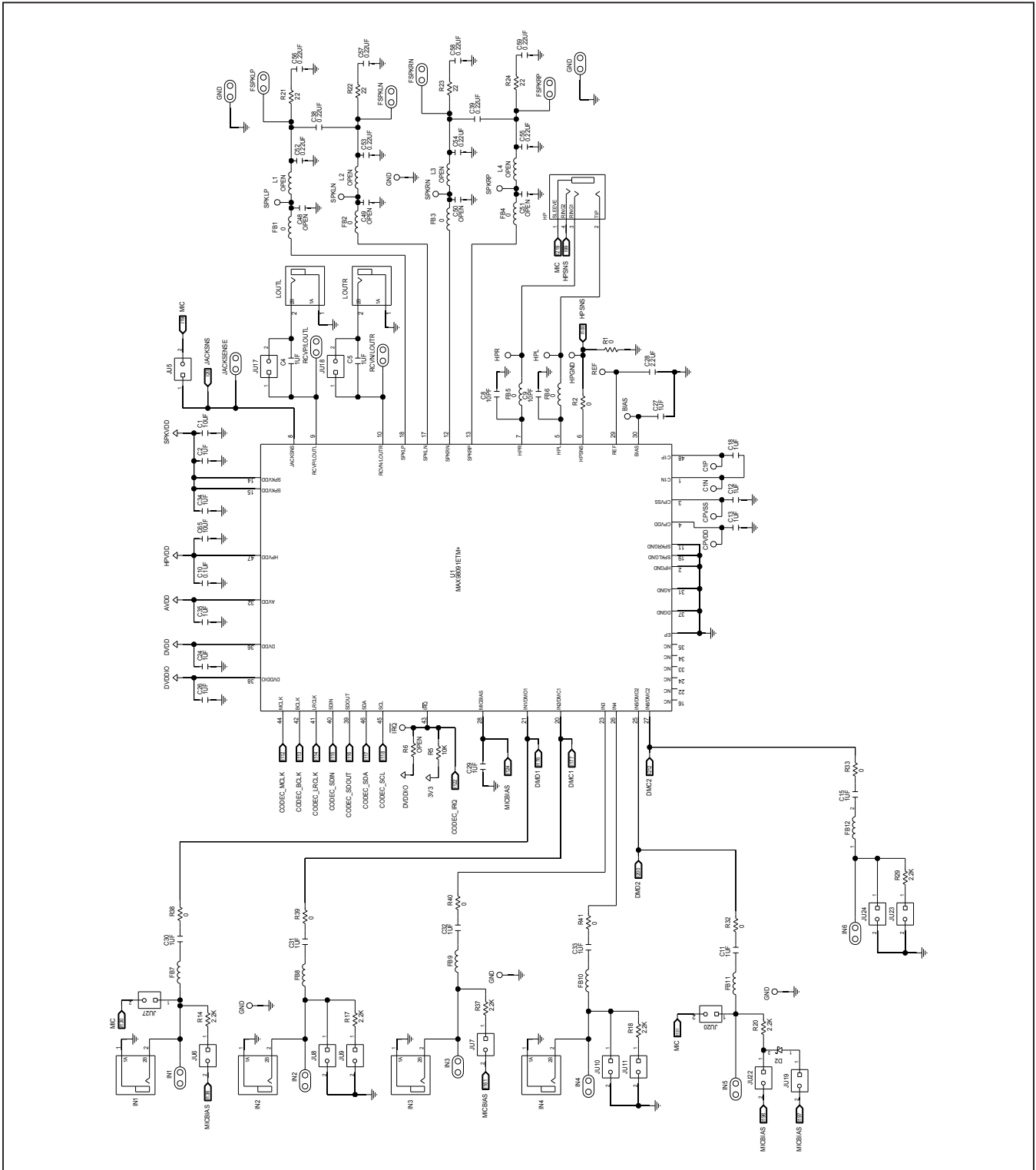



MAX98091 (TQFN) EV Kit Schematic (continued)

DIGITAL MICROPHONES

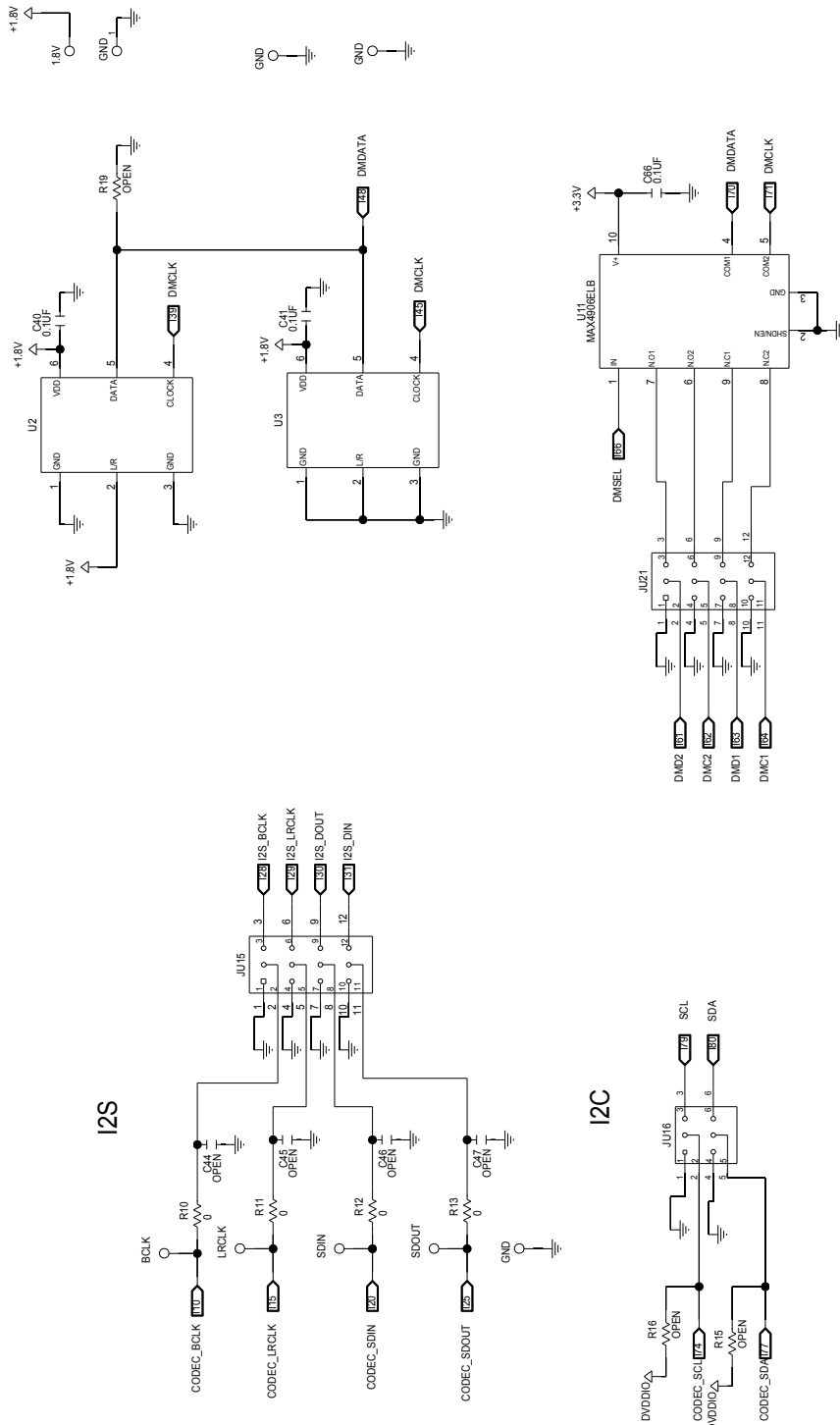

MAX98091 (TQFN) EV Kit Schematic (continued)

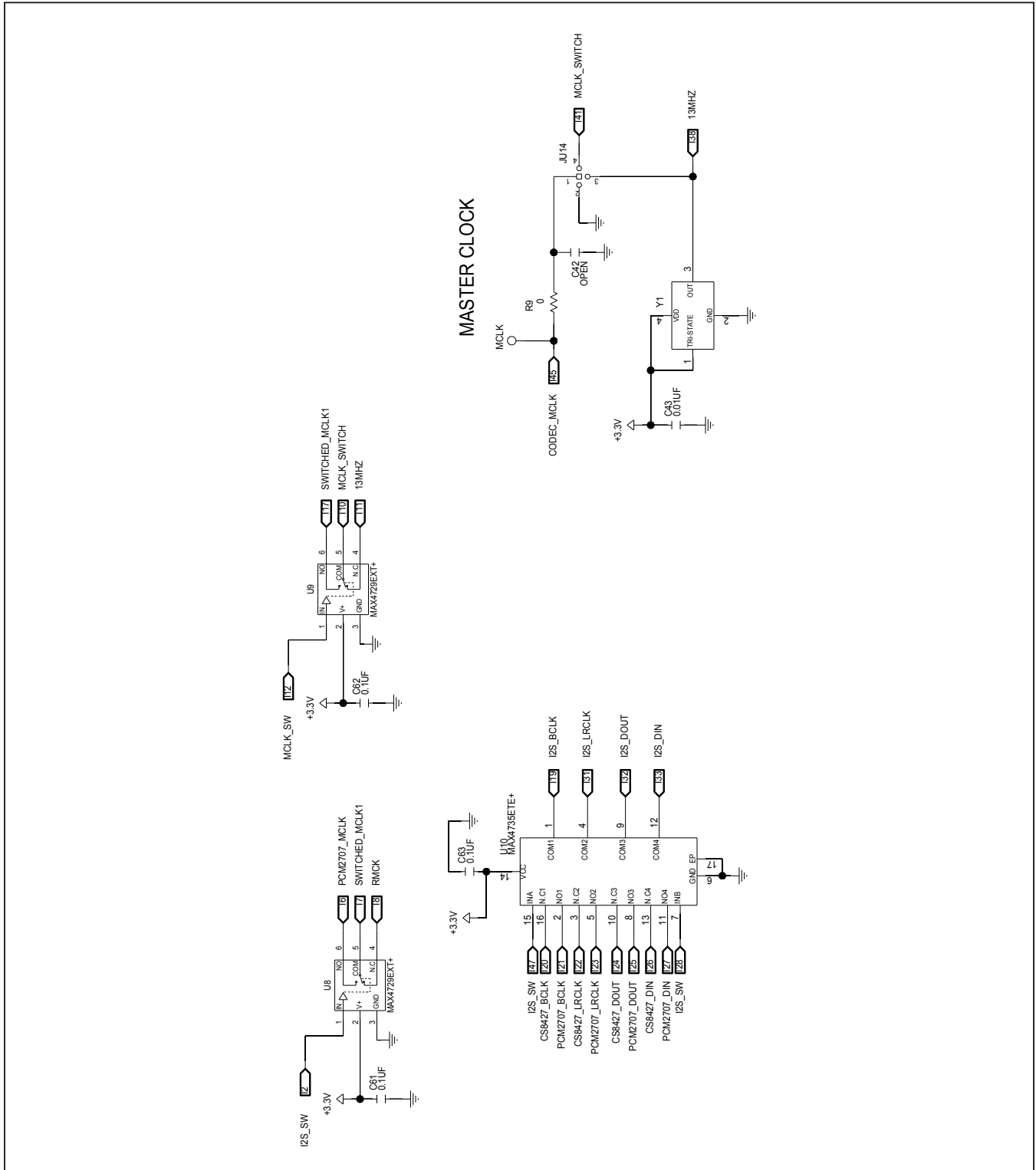

MAX98091 (TQFN) EV Kit Schematic (continued)

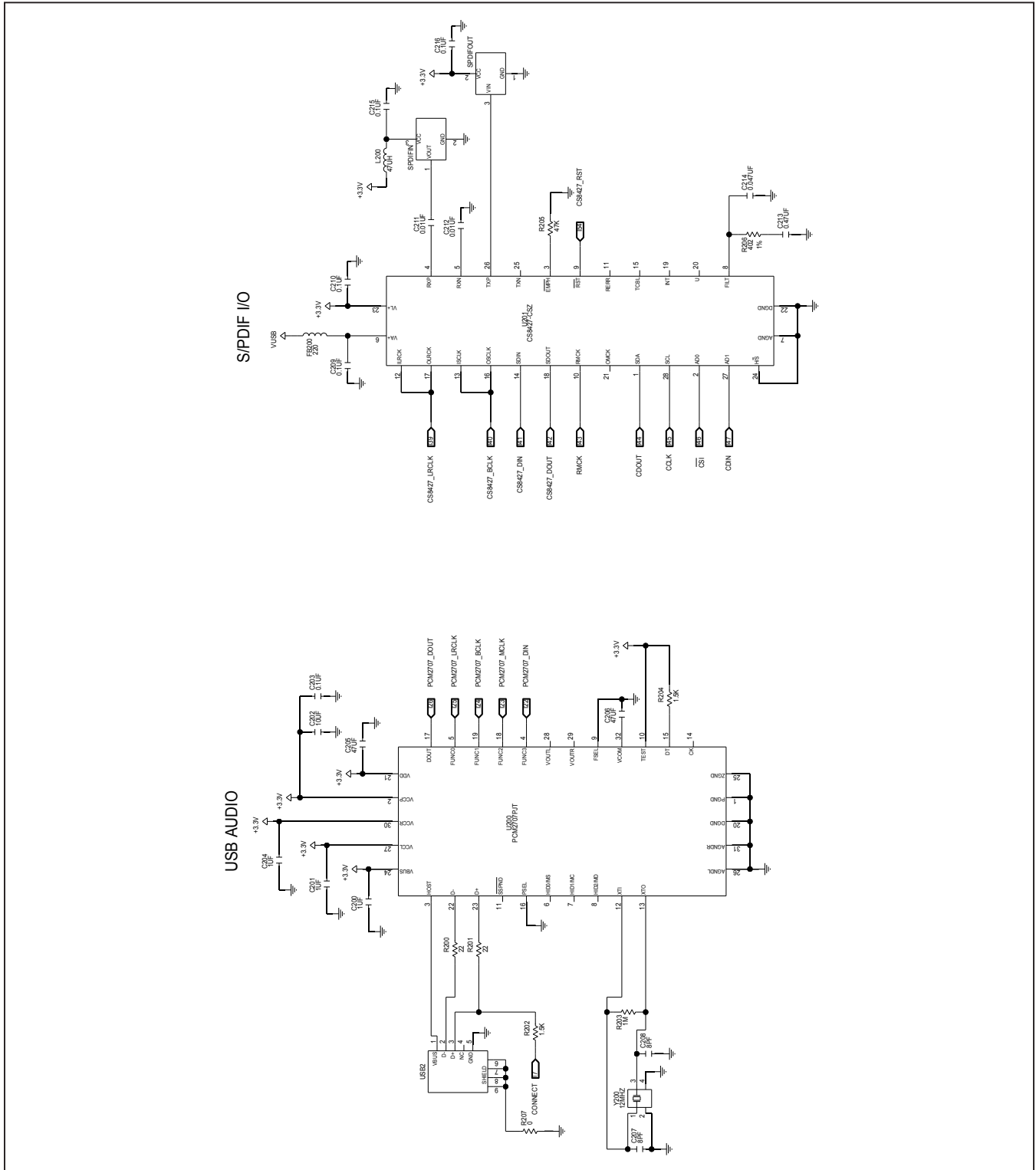

MAX98091 (TQFN) EV Kit Schematic (continued)

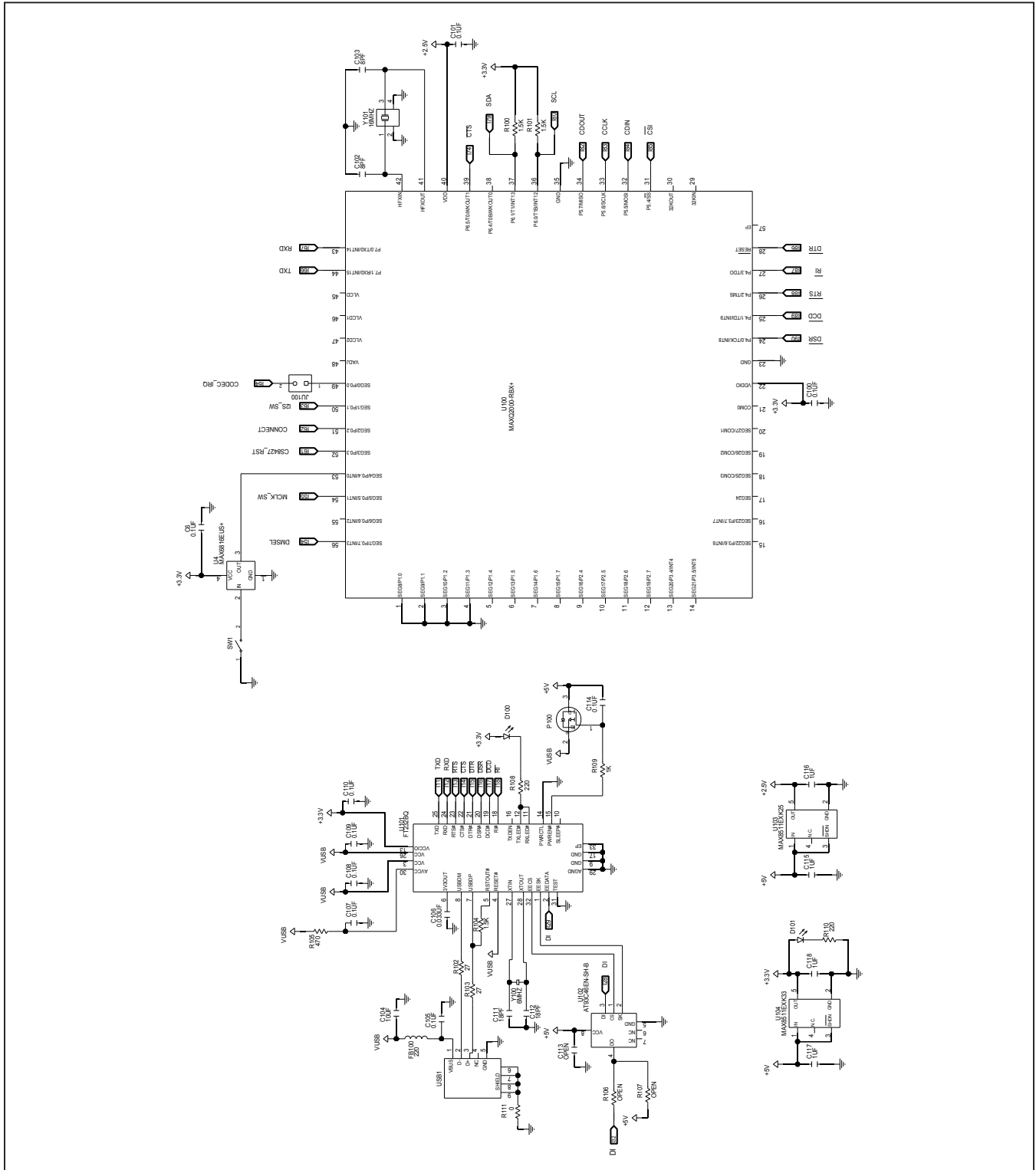

MAX98091 (TQFN) EV Kit Schematic (continued)

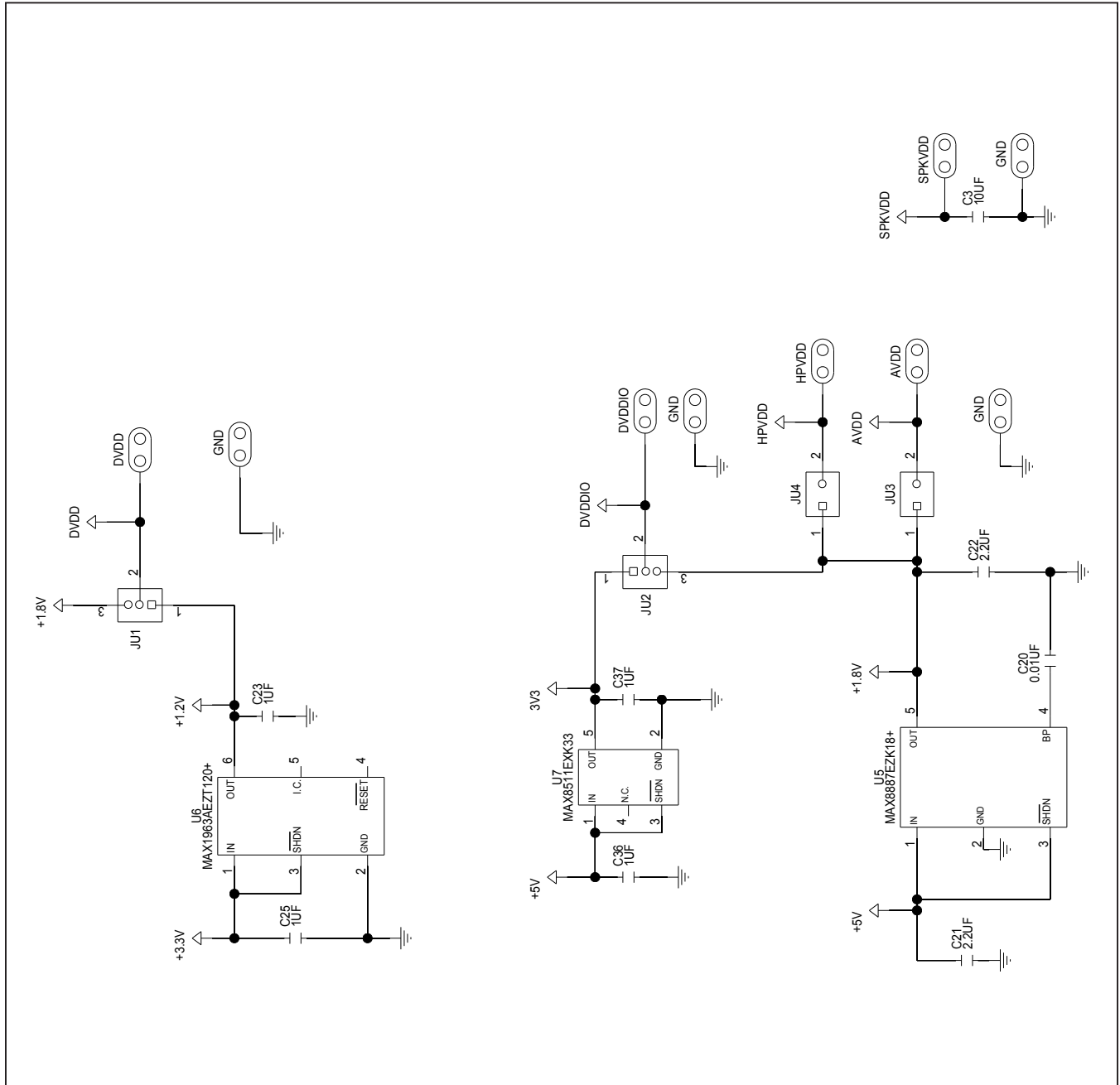

MAX98091 (TQFN) EV Kit PCB Layouts

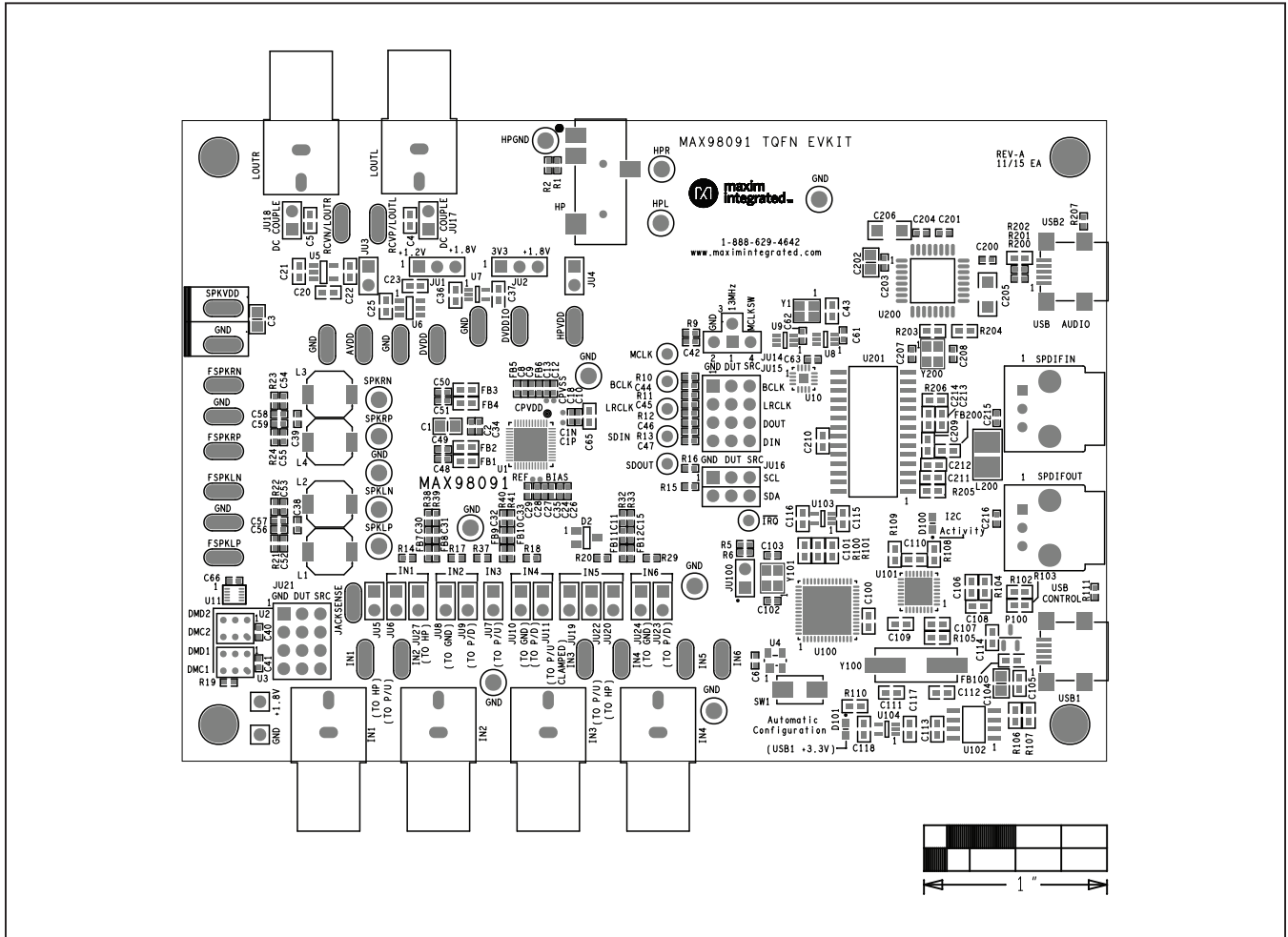

MAX98091 TQFN EV Kit Component Placement Guide—Top Silkscreen

**MAX98091 (TQFN) EV Kit PCB Layouts (continued)**

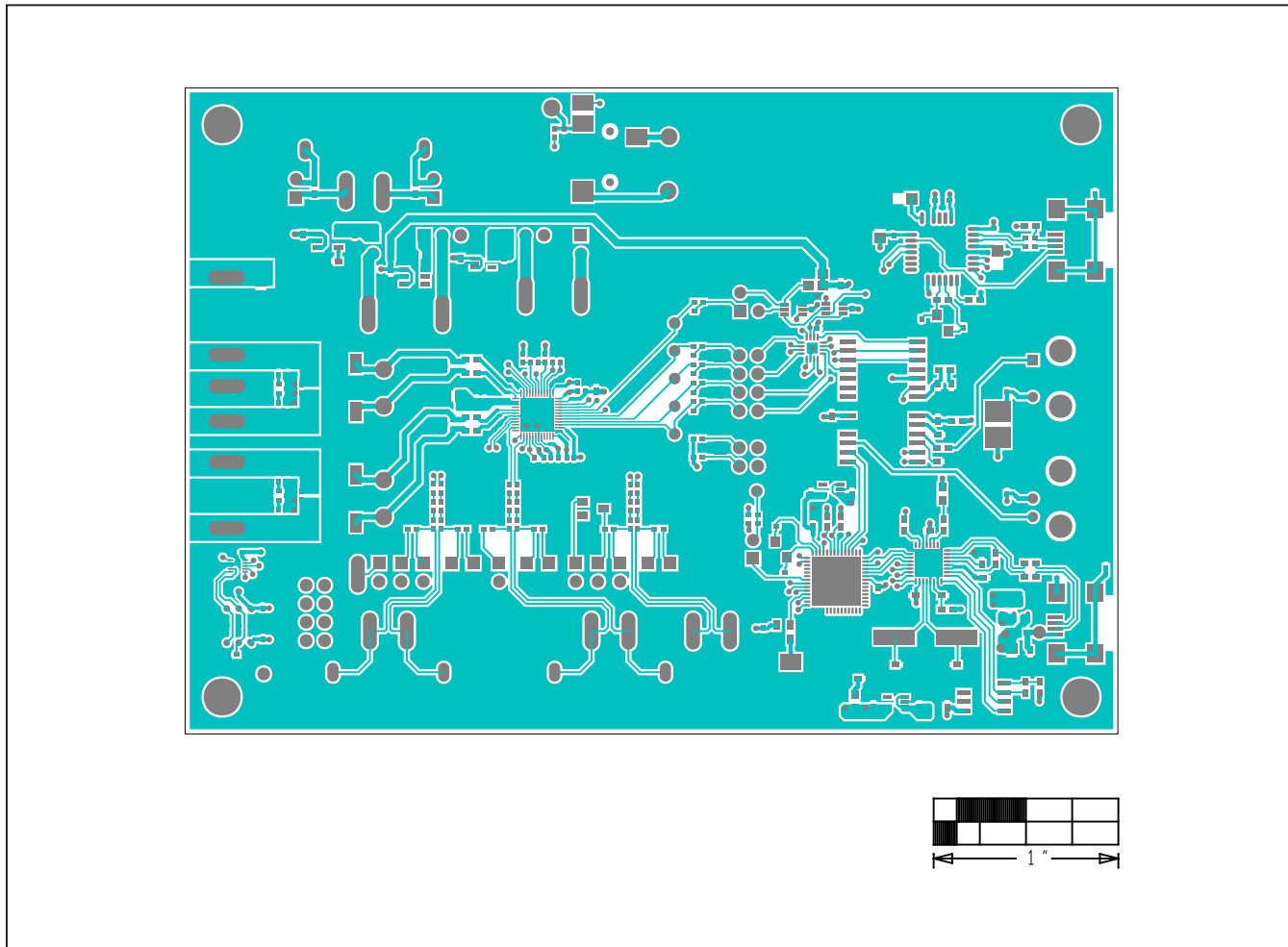

MAX98091 TQFN EV Kit PCB Layout—Top Layer

MAX98091 (TQFN) EV Kit PCB Layouts (continued)

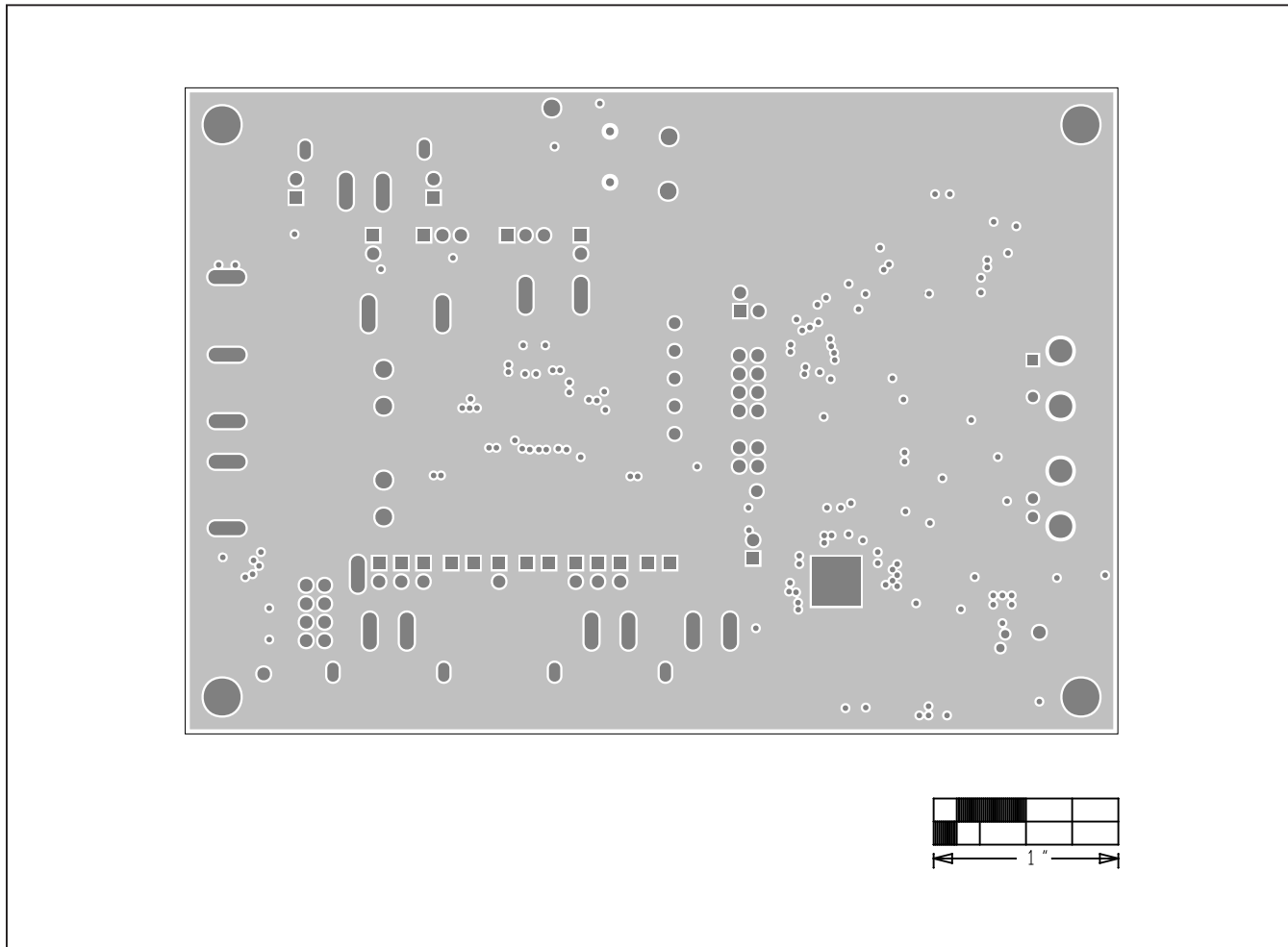

MAX98091 TQFN EV Kit PCB Layout—Internal Layer 2 GND



MAX98091 (TQFN) EV Kit PCB Layouts (continued)

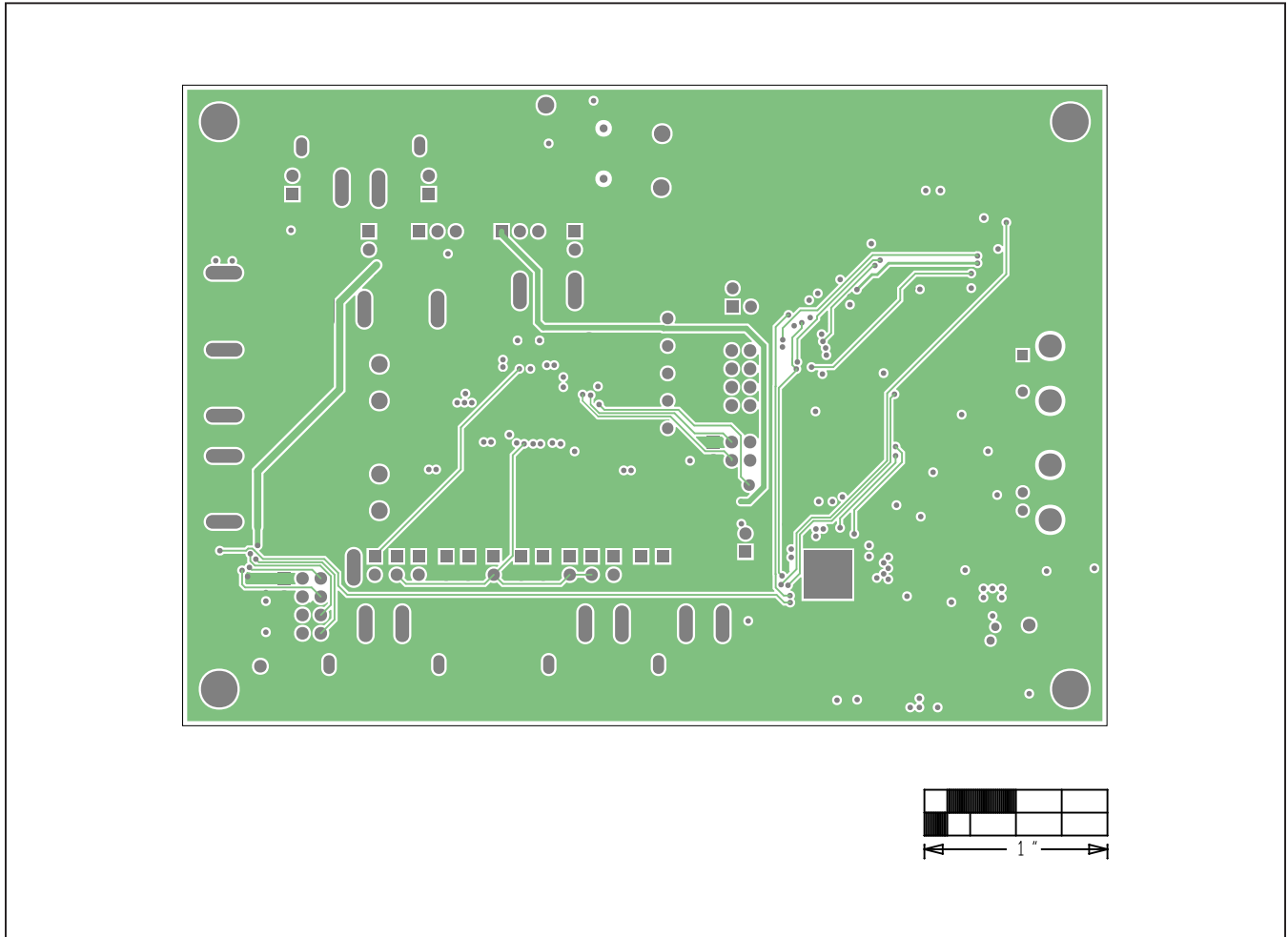

MAX98091 TQFN EV Kit PCB Layout—Internal Layer 3 SIG

MAX98091 (TQFN) EV Kit PCB Layouts (continued)

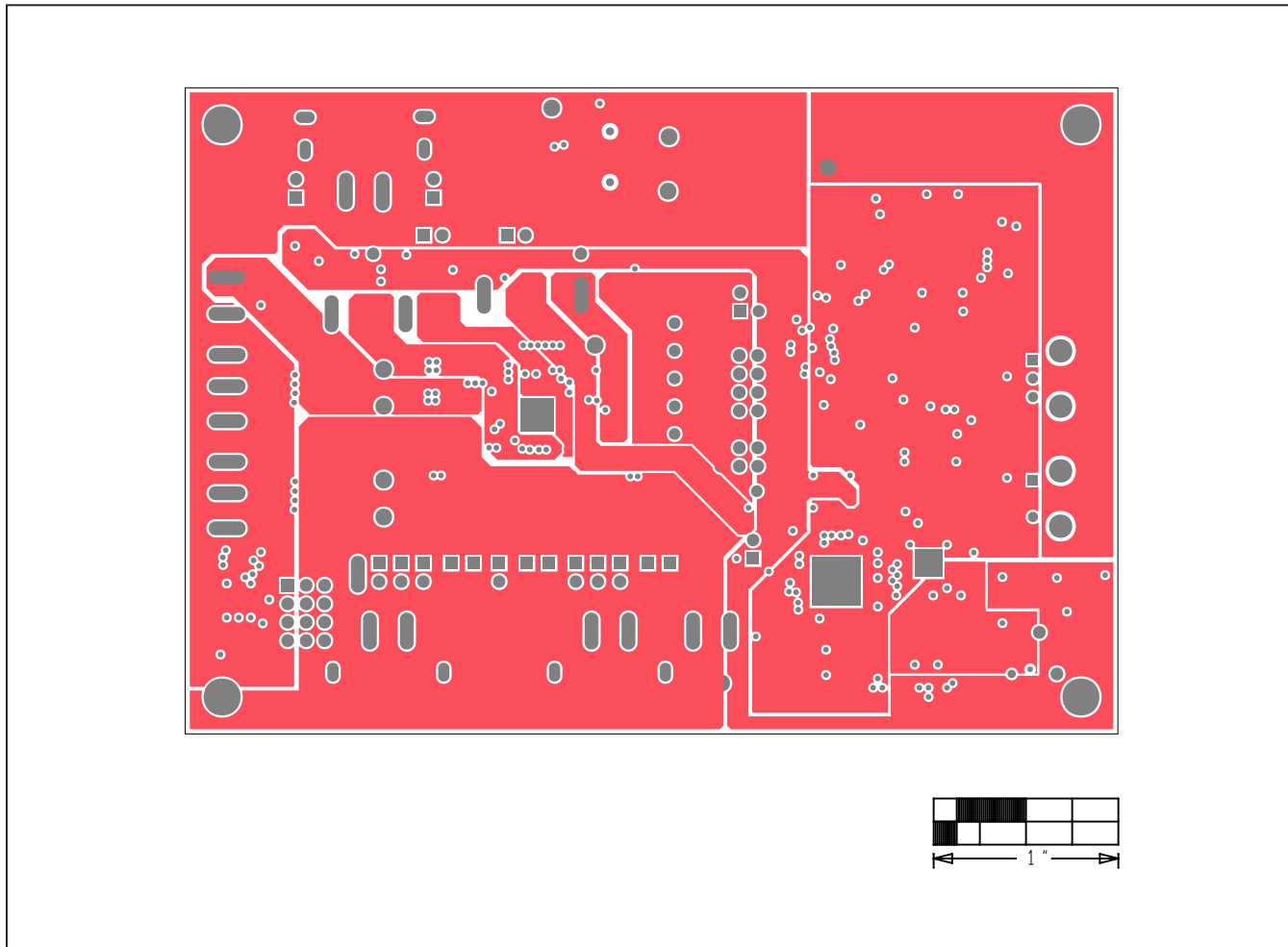

MAX98091 TQFN EV Kit PCB Layout—Internal Layer 4 VDD

MAX98091 (TQFN) EV Kit PCB Layouts (continued)

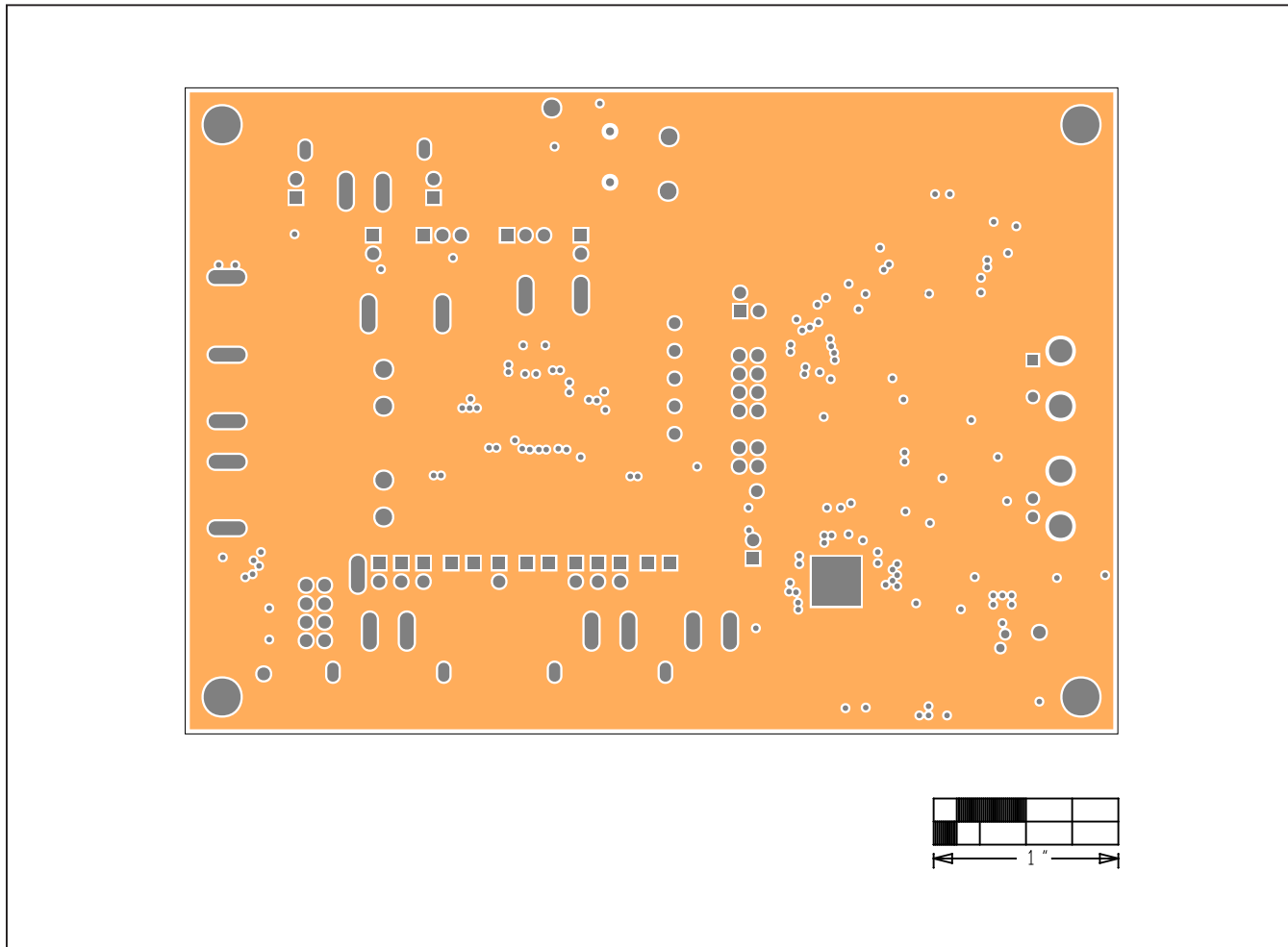

MAX98091 TQFN EV Kit PCB Layout—Internal Layer 5 GND1

MAX98091 (TQFN) EV Kit PCB Layouts (continued)

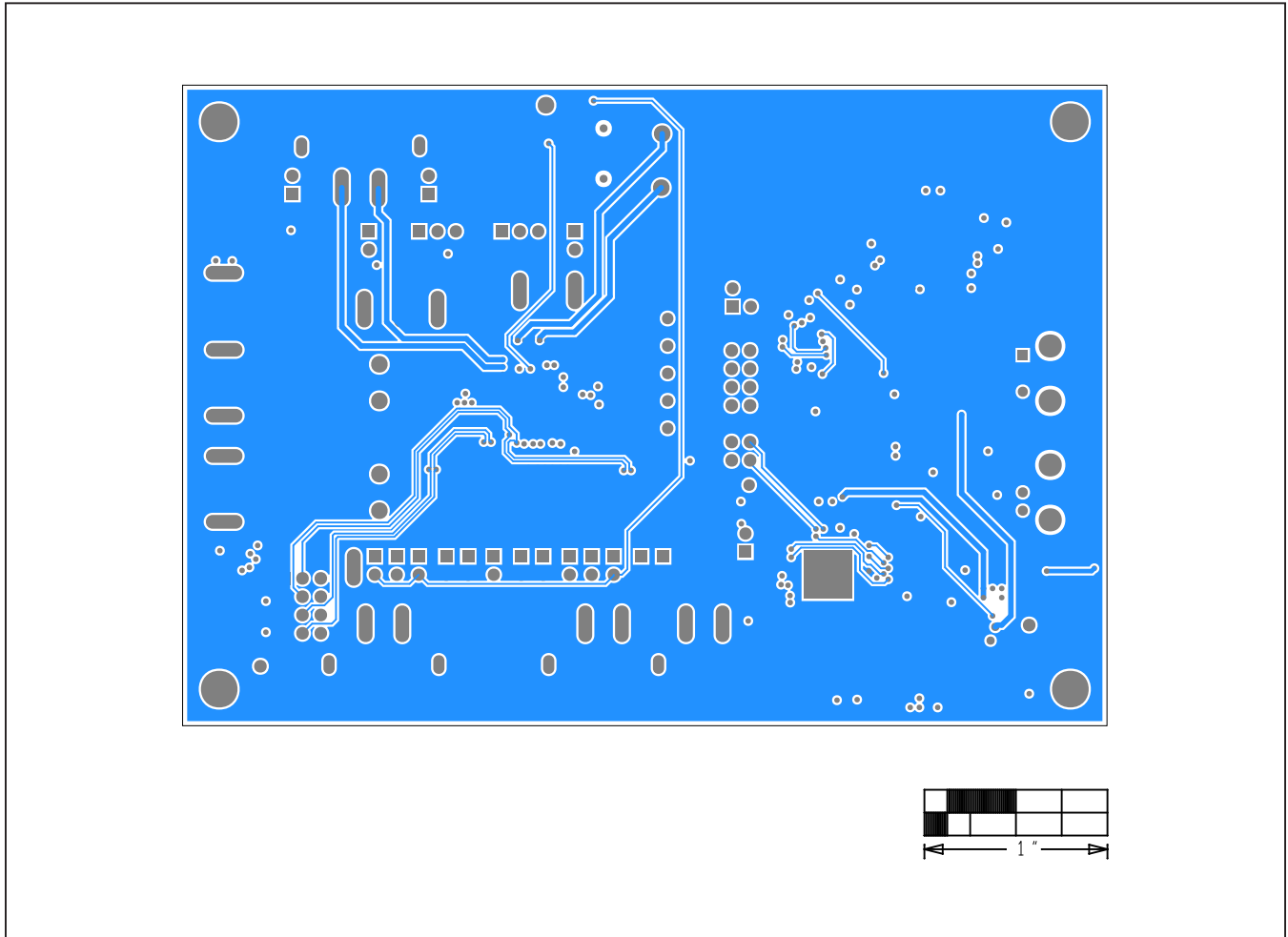

MAX98091 TQFN EV Kit PCB Layout—Bottom Layer

## Revision History

REVISION NUMBER	REVISION DATE	DESCRIPTION	PAGES CHANGED
0	6/17	Initial release	—

For pricing, delivery, and ordering information, please contact Maxim Direct at 1-888-629-4642, or visit Maxim Integrated's website at [www.maximintegrated.com](http://www.maximintegrated.com).

*Maxim Integrated cannot assume responsibility for use of any circuitry other than circuitry entirely embodied in a Maxim Integrated product. No circuit patent licenses are implied. Maxim Integrated reserves the right to change the circuitry and specifications without notice at any time.*