



# MAX9943 Evaluation Kit

**Evaluates: MAX9943**

## General Description

The MAX9943 evaluation kit (EV kit) is a fully assembled and tested PCB that evaluates the MAX9943 high-voltage, precision, low drift, and low-power op amp.

## Features

- ◆ Flexible Input and Output Configurations
- ◆ +6V to +38V Single Supply Range
- ◆  $\pm 3V$  to  $\pm 19V$  Dual Supply Range
- ◆ Fully Assembled and Tested

## Ordering Information

PART	TYPE
MAX9943EVKIT+	EV Kit

+ Denotes lead(Pb)-free and RoHS compliant.

## Component List

DESIGNATION	QTY	DESCRIPTION
C1, C2	2	10 $\mu$ F $\pm 20\%$ , 25V tantalum capacitors (C size) AVX TAJC106M025R
C3, C4	2	0.1 $\mu$ F $\pm 10\%$ , 50V X7R ceramic capacitors (0603) Murata GRM188R71H104K
C5	0	Not installed, capacitor (0603)
GND	5	Multipurpose test points, black
JU1, JU2	2	3-pin headers
OUT, VIN-, VIN+	3	Multipurpose test points, white
R1, R2	2	1k $\Omega$ $\pm 5\%$ resistors (0603)

DESIGNATION	QTY	DESCRIPTION
R3	1	0 $\Omega$ $\pm 5\%$ resistor (0603)
R4	0	Not installed, 1W through-hole resistor
U1	1	High-voltage, precision, low-power op amp (6 TDFN-EP*) Maxim MAX9943ATT+
VCC, VEE	2	Multipurpose test points, red
—	1	PCB: MAX9943 EVALUATION KIT+

\*EP = Exposed pad.

## Component Suppliers

SUPPLIER	PHONE	WEBSITE
AVX Corporation	843-946-0238	www.avxcorp.com
Murata Electronics North America, Inc.	770-436-1300	www.murata-northamerica.com

**Note:** Indicate that you are using the MAX9943 when contacting these component suppliers.

# MAX9943 Evaluation Kit

## Quick Start

### Required Equipment

- MAX9943 EV kit
- +15V power supply (VCC)
- -15V power supply (VEE)
- Waveform generator
- Oscilloscope

### Procedure

The MAX9943 EV kit is fully assembled and tested. Follow the steps below to verify board operation:

- 1) Verify that all jumpers are in their default positions, as shown in Table 1.
- 2) Set the VCC power-supply output to +15V. Disable the output.
- 3) Set the VEE power-supply output to -15V. Disable the output.
- 4) Set the waveform-generator output to 1kHz sine wave,  $V_{P-P} = +3V$ . Disable the output.
- 5) Connect the positive terminal of the VCC power supply to the VCC test point. Connect the ground terminal of the VCC power supply to the GND test point.
- 6) Connect the negative terminal of the VEE power supply to the VEE test point. Connect the ground terminal of the VEE power supply to the GND test point.
- 7) Connect the waveform-generator output to the VIN+ test point.
- 8) Connect the waveform-generator ground to the GND test point.
- 9) Connect the positive input of the oscilloscope to the OUT test point.
- 10) Connect the negative input of the oscilloscope to the GND test point.
- 11) Enable the VCC and VEE power supplies.
- 12) Enable the waveform-generator output.
- 13) Verify that  $V_{OUT} = 2 \times V_{VIN+}$  or a  $6V_{P-P}$  sine wave.

## Detailed Description of Hardware

### Power Supplies

The MAX9943 EV kit can operate with dual supplies from  $\pm 3V$  to  $\pm 19V$ , or with a single supply from +6V to +38V with respect to ground. Appropriate bypass capacitors are provided to the VCC and VEE power-supply inputs.

### Input and Output Configurations

The EV kit provides jumpers JU1 and JU2 for flexible input configurations. For noninverting-amplifier configuration, place shunts on pins 1-2 of JU1 and pins 2-3 of JU2. For inverting-amplifier configuration, place shunts on pins 1-2 of JU2 and pins 2-3 of JU1. Table 1 summarizes the functions of JU1 and JU2.

### Capacitive-Load Driving

The EV kit provides the C5 and R3 footprints for optional capacitive-load driving circuit. C5 simulates the capacitive load while R3 acts as the isolation resistor to improve the op amp's stability at higher capacitive loads. For additional details, refer to the *Capacitive Load Stability* section in the MAX9943 IC data sheet.

**Table 1. Jumper Descriptions (JU1, JU2)**

CONFIGURATION	JUMPER	SHUNT POSITIONS	DESCRIPTION
Noninverting	JU1	1-2*	$V_{OUT} = \left(1 + \frac{R2}{R1}\right) \times V_{VIN+}$ where $V_{VIN+}$ is the voltage applied at the VIN+ test point.
	JU2	2-3*	
Inverting	JU1	2-3	$V_{OUT} = -\frac{R2}{R1} \times V_{VIN-}$ where $V_{VIN-}$ is the voltage applied at the VIN- test point.
	JU2	1-2	

\*Default position.

# MAX9943 Evaluation Kit

Evaluates: MAX9943

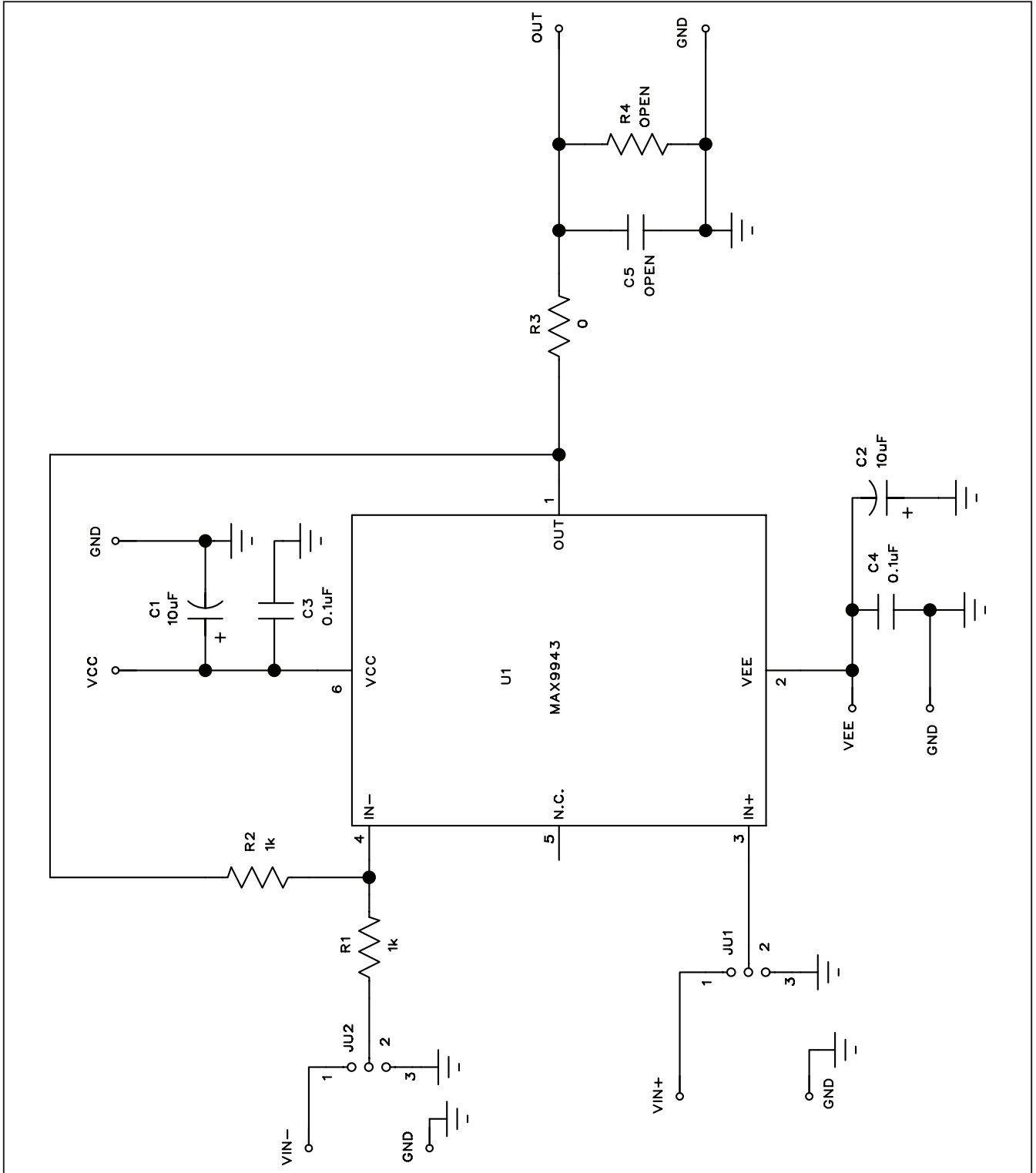

Figure 1. MAX9943 EV Kit Schematic

# MAX9943 Evaluation Kit

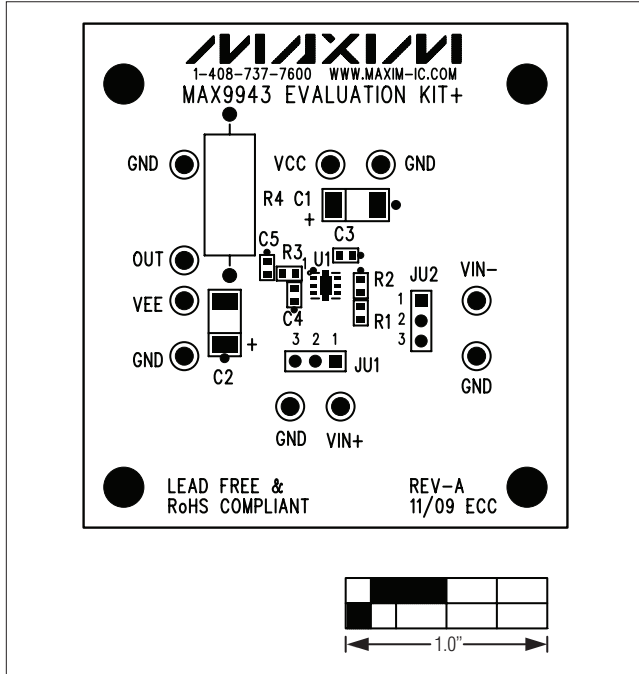

Figure 2. MAX9943 EV Kit Component Placement Guide—Component Side

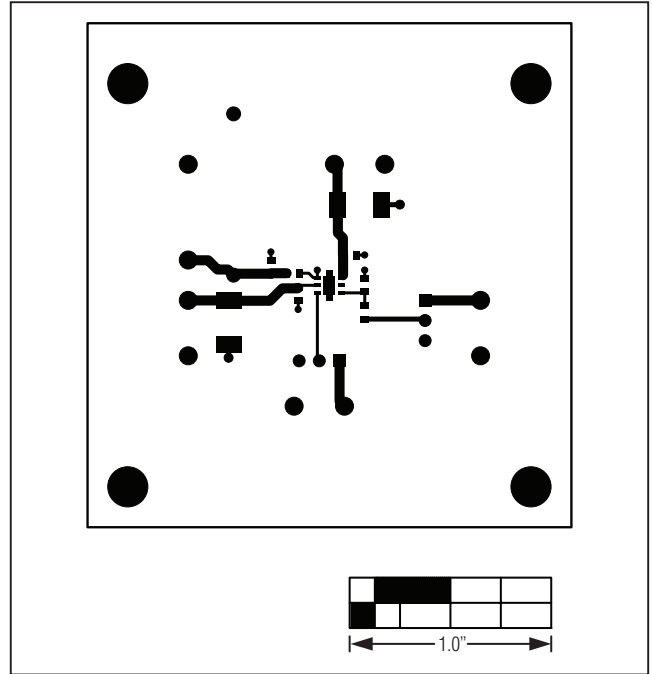

Figure 3. MAX9943 EV Kit PCB Layout—Component Side

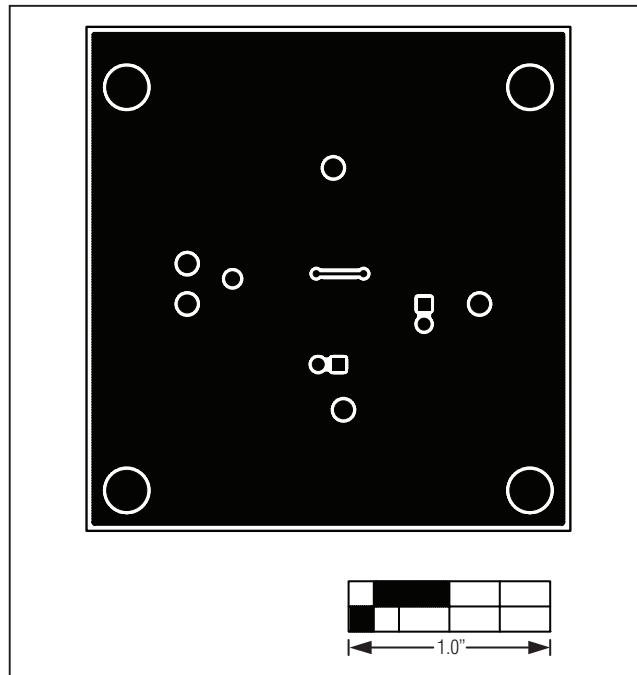

Figure 4. MAX9943 EV Kit PCB Layout—Solder Side

Maxim cannot assume responsibility for use of any circuitry other than circuitry entirely embodied in a Maxim product. No circuit patent licenses are implied. Maxim reserves the right to change the circuitry and specifications without notice at any time.

4 \_\_\_\_\_ **Maxim Integrated Products, 120 San Gabriel Drive, Sunnyvale, CA 94086 408-737-7600**