



Installation Guide

PC-Based Logic Analyzer

Index

1	Features of AKIP Logic Analyzer	5
1.1	Package Contents.....	6
1.2	Introduction	8
1.3	Hardware Specifications	10
1.4	System Requirements.....	12
1.4.1	Operating System Requirements	12
1.4.2	Hardware System Requirements	12
1.5	Device Maintenance and Safety	13
2	Installation	15
2.1	Software Installation.....	16
2.2	Hardware Installation	18
2.3	Tips and Advice.....	20
3	User Interface	21
3.1	Menu & Tool Bars.....	24
3.2	Find Data Value.....	72
3.3	Statistics Feature	75
3.4	Customize Interface	79
3.4.1	Modify Waveform Display Mode.....	80
3.4.2	Modify Ruler Mode	81
3.4.3	Modify Waveform Height & Correlated Setting	82
3.5	Auto Save.....	85
3.6	Color Setting	86
3.6.1	Modify Workaround Color.....	88
3.6.2	Modify Waveform Color	89
3.7	The Flow of Software Operation	91
4	Introduction to Logic Analysis	92
4.1	Logic Analysis	93
4.2	Bus Logic Analysis	104
4.3	Plug Analysis.....	107
4.4	Bus Packet List	109
4.5	Bus Analysis.....	115
4.5.1	Bus Analysis	116
4.5.2	I2C Analysis.....	120
4.5.3	UART Analysis.....	127
4.5.4	SPI Analysis	132

4.5.5	1-WIRE Analysis.....	137
4.5.6	HDQ Analysis	147
4.5.7	CAN 2.0B Analysis.....	154
4.6	Compression.....	164
4.6.1	Software Basic Setup of Compression.....	164
4.7	Signal Filter and Filter Delay.....	166
4.7.1	Basic Setup of Signal Filter and Filter Delay.....	166
4.8	Noise Filter	170
4.8.1	Basic Software Setup of Noise Filter.....	170
4.9	Data Contrast.....	172
4.9.1	Basic Software Setup of Data Contrast.....	172
4.10	Refresh Protocol Analyzer	175
4.10.1	Basic Software Setup of Refresh Protocol Analyzer	175
4.11	Multi-stacked Logic Analyzer Settings	177
4.11.1	Basic Software Setup of Multi-stacked Logic Analyzer Settings	177
4.12	DSO-stacked Settings	179
4.13	Memory Analyzer	188
4.13.1	Basic Software Setup of Memory Analyzer	188
5	Troubleshooting	192
5.1	Installation Troubleshooting	193
5.2	Software Troubleshooting	194
5.3	Hardware Troubleshooting.....	195
6	FAQ	196
6.1	Hardware.....	197
6.2	Software	199
6.3	Registration.....	203
6.4	Technical Information	204
6.5	Others	205
7	Appendix	206
7.1	Hot Keys.....	207

Preface

This Quick Start Guide is designed to help new and intermediate users navigate and perform common tasks with the AKIP Logic Analyzer. Despite its simple packaging and interface, the Logic Analyzer is a sophisticated measurement and analysis tool. It is also a highly sensitive electrical current sensing device. Users must carefully read instructions and procedures pertaining to installation and operation. Any instrument connected to the unit should be properly grounded. A pair of anti-static gloves is strongly recommended when performing a task with the device. To ensure accuracy and consistency of output data, use of the bundled components is strongly recommended.

Users' opinions are very important to AKIP. Please contact our engineering team by telephone, fax or email with your questions or feedback. Thank you for choosing the AKIP Logic Analyzer.

Notice: We will not have additional notice for you, when there is any modification to the User Manual. If there is any unconformity caused by software upgrade, users should take the software as the standard.

1 Features of AKIP Logic Analyzer

- 1.1 Package Contents
- 1.2 Introduction
- 1.3 Hardware Specifications
- 1.4 System Requirements
- 1.5 Device Maintenance and Safety

Objective

In this chapter, users will learn about the package contents, description, hardware specifications, system requirements, and safety issues of the AKIP Logic Analyzer. Although this chapter is purely informative, we highly recommend reading this carefully to ensure safety and accuracy when performing any operation with the AKIP Logic Analyzer.

1.1 Package Contents

Verify the package contents before discarding packing materials. The following components should be included with your product. For assistance, please contact our nearest distributor.

Table 1-1: Accessories List

Models	AKIP-9101	AKIP-9102	AKIP-9103	AKIP-9103/1
Logic Analyzer	1	1	1	1
16-Pin Testing Cable	0	1	1	1
8-Pin Testing Cable	2	2	2	2
Probe	20	36	36	36
USB Cable	1	1	1	1
Quick Start Guide	1	1	1	1
Driver CD**	1	1	1	1
1-Pin Testing Cable (White)	1	1	1	1
2-Pin Testing Cable (Black)	1	1	1	1

* This Driver CD contains multilingual software interface program as well as multilingual User Manual.



Fig. 1-1: Logic Analyzer



16-Pin x 1
8-Pin x 2

Fig. 1-2: Testing Cable

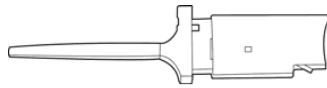

Fig. 1-3: Probe
(varied depending on models)



Fig. 1-4: USB Cable



Fig. 1-5: Quick Start Guide

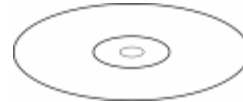

Fig. 1-6: Driver CD



Fig. 1-7: 1-Pin External Clock Cable
(White)



Fig. 1-8: 2-Pin Ground Cable
(Black)

1.2 Introduction

The AKIP Logic Analyzer models, AKIP-9101, AKIP-9102, AKIP-9103 and AKIP-9103/1, all share the same external features as illustrated in the following figures.



Fig. 1-9: A View of the AKIP Logic Analyzer. See Fig 1-11 for detailed information on the **Signal Connectors**.



Fig. 1-10: Side View of the AKIP Logic Analyzer; the power of the Logic Analyzer is drawn from the USB connection.

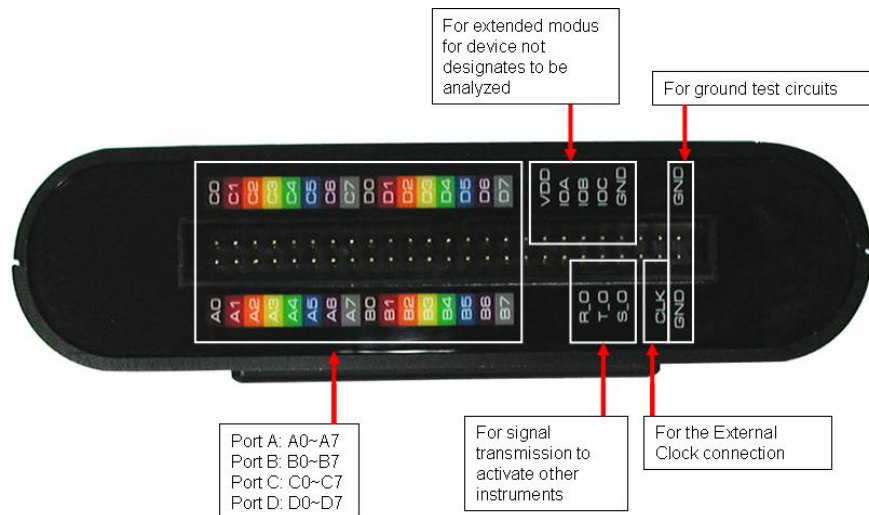

Fig. 1-11: Side View of the AKIP Logic Analyzer

Table 1-2: List of Functional Pins in Each Model

Models	AKIP-9101	AKIP-9102	AKIP-9103	AKIP-9103/1
Port A (A0~A7)	√	√	√	√
Port B (B0~B7)	√	√	√	√
Port C (C0~C7)	X	√	√	√
Port D (D0~D7)	X	√	√	√
R_O	√	√	√	√
T_O	√	√	√	√
S_O	√	√	√	√
CLK	√	√	√	√
GND	√	√	√	√
VDD	√	√	√	√
IOA	√	√	√	√
IOB	√	√	√	√
IOC	√	√	√	√
GND	√	√	√	√

Table 1-3: Definitions and Functions of Pins for All Models

CLK	Clock	Connect a given external module to be analyzed.
GND	Ground	Two pins used for grounding the Logic Analyzer with a given external module to be analyzed.

Table 1-4: Definitions and Functions of Pins for Advanced Models (1)

R_O	Read (Out)	When the Logic Analyzer is about to upload data from the memory to the PC, the R_O will send a Rising Edge signal of DC3.3V. When the upload is finished, a Falling Edge signal is sent.
T_O	Trigger (Out)	When a trigger condition is established, the T_O will send a Rising Edge signal of DC3.3V. When the memory is full, a Falling Edge signal is sent.
S_O	Start (Out)	When a user initiates a sampling task by clicking the RUN icon in the window or clicking the START button on the device, the S_O will send a Rising Edge signal of DC3.3V. When the Logic Analyzer finishes uploading, a Falling Edge signal is sent.

Table 1-5: Definitions and Functions of Pins for Advanced Models (2)

VDD	Voltage Drain (Semiconductor)	Provide +3.3 V for external modules by draining voltage from the Logic Analyzer.
IOA	Ext. I/O Module A	Transmit signals between an external model or device and the Logic Analyzer.
IOB	Ext. I/O Module B	Same as IOA .
IOC	Ext. I/O Module C	Same as IOA .
GND	Ground	Ground external devices in sequence.

1.3 Hardware Specifications

Table 1-6: Hardware Specifications of AKIP Series

Items\Type		AKIP-9101	AKIP-9102	AKIP-9103	AKIP-9103/1
Interface		USB 2.0 (1.1)			
Operating System		Windows 2000/ Windows XP/ Windows Vista/ Windows 7			
Power Supply		USB 1.1 (USB 2.0 Recommended)			
Channels		16	32		
Sampling Rate	Internal Clock Rate (asynchronous)	100Hz ~ 200MHz			
	Max External Clock (synchronous)	Max 100MHz			
	Bandwidth				
Memory	Memory	4M Bits	4M Bits	32M Bits	64M Bits
	Memory Depth (Per Channel)	128K Bits	128K Bits	1M Bits	2M Bits
Trigger	Trigger Channel	16 Channels	32 Channels		
	Trigger Condition	Pattern/Edge			
	Pre-Trigger/ Post-Trigger	Yes			
	Trigger Level	1 Level			
	Trigger Count	1~65535			
Threshold Voltage	Working Voltage	-6V~+6V			
	Accuracy	±0.1V			
Protocol Analyzer (Keep Increasing)	I2C	Free			
	UART	Free			
	SPI	Free			
	1-WIRE	Option	Free		
	CAN 2.0B	Option		Free	
	HDQ	Option		Free	
	7-SEGMENT LED	Free			
Software	Operating Interface Language	Chinese(Si)/ Chinese(Tr)/ English			
	Time Base Range	5ps~10Ms			
	Vertical Sizing	1~5.5			
	Compression	Max 32Mbits	Max 32Mbits	Max 255Mbits	Max 512Mbits
	Waveform Width Display	Yes			

Function	Trigger Page	1~8192Page		
	Pulse Width Trigger	Free		
	Double Mode	Yes		
	Trigger Mark	Option		Free
	Latch Function	Option		Free
	Data Contrast	Option		Free
	Multi-stacked Logic Analyzer Settings	No	Yes	
	Protocol Analyzer Trigger	Option		Free
Safety Certification		FCC/CE/WEEE/RoHS		

1.4 System Requirements

This section discusses basic operating system and hardware requirements for the Logic Analyzer. Software and hardware capability may vary along with PC configuration. This manual assumes that one of supported operating systems(listed below) is properly installed.

1.4.1 Operating System Requirements

	Support	Non-support
Operating System Name	<ul style="list-style-type: none"> ● Windows 2000 (Professional, Server Family) ● Windows XP (Home, Professional Editions 32-Bit version) ● Windows VISTA (32-Bit) ● Windows 7 (32-Bit and 64-Bit version) 	<ul style="list-style-type: none"> ● Windows NT 4.0 (Workstation & Server, Service Pack 6) ● Windows Server 2003

1.4.2 Hardware System Requirements

Hardware Name	Lowest Configuration	Recommended Configuration
CPU	166 MHz	900 MHz
Memory	64MB	256MB
Display Device	VGA Display Capability with 1024x768 resolution or higher.	VGA Display Capability with 1024x768 resolution or higher.
Hard Drive	At least 100MB available space	At least 100MB available space
USB	USB1.1 supported	USB2.0 recommended

1.5 Device Maintenance and Safety

Follow these instructions for proper operation and storage of the Logic Analyzer.

Table 1-7: General Advice

Cautions	<ul style="list-style-type: none"> Do not place heavy objects on the AKIP Logic Analyzer. Avoid hard impacts and rough handling. Protect the AKIP Logic Analyzer from static discharge. Do not disassemble the AKIP Logic Analyzer; this will void the warranty and could affect its operation.
Cleaning	<ul style="list-style-type: none"> Use a soft, damp cloth with a mild detergent to clean. Do not spray any liquid on the AKIP Logic Analyzer or immerse it in any liquid. Do not use harsh chemicals or cleaners containing substances such as benzene, toluene, xylene or acetone.

Table 1-8: Electrical Specifications

Items	Minimum	Typical	Maximum
Working Voltage	DC 4.5 V	DC 5.0 V	DC 5.5 V
Current at Rest			200 mA
Current at Work			400 mA
Power at Rest			1 W
Power at Work			2W
Error in Phase Off*			1.5 nS
V_{input} of Testing Channel	DC -30V		DC 30 V
V_{Reference}	DC -6V		DC 6 V
Input Resistance		500K Ω /10pF	
Working Temperature	5°C		70°C
Storage Temperature	-40°C		80°C

* Refer to the User Manual for error analysis calculation.

Table 1-9: Operating Environment

<p>WARNING</p>	<ul style="list-style-type: none"> • Avoid direct sunlight • Use in a dust free, non-conductive environment (see Note) • Relative Humidity: < 80% • Altitude: < 2000m • Temperature: 0 ~ 40 Degrees C <p>This is a Class A product which may cause radio interference in a <u>domestic environment</u>.</p> <p>Note: EN 61010-1:2001 specify degrees of pollution and their requirements. Logic Analyzer falls under Level 2.</p> <p>Pollution refers to 'addition of foreign matter, solid, liquid or gaseous (ionized gases), which may produce a reduction of dielectric strength or surface resistivity'.</p> <p>Pollution Degree 1: No pollution or only dry, non-conductive pollution occurs. This pollution has no effect.</p> <p>Pollution Degree 2: Normally only non-conductive pollution occurs. Occasionally, however, temporary conductivity caused by the condensation must be expected.</p> <p>Pollution Degree 3: Conductive pollution occurs or dry, non-conductive pollution which becomes conductive due to the condensation occurs. In such conditions, the equipment is normally protected against exposure to direct sunlight, precipitation and wind, but neither temperature nor humidity is controlled.</p>
<p>Storage Environment</p>	<p>Relative Humidity: < 80% Temperature: 0 ~ 50 Degrees C</p>

Conclusion

After reading this section, users should have a basic grasp of the Logic Analyzer. A complete understanding of the section, **Device Maintenance and Safety**, is a critical prerequisite of any further operation as presented in the User Manual.

2 Installation

- 2.1 Software Installation
- 2.2 Hardware Installation
- 2.3 Tips and Advice

Objective

This chapter describes the installation of the Logic Analyzer hardware and software. Software installation steps must be followed precisely to ensure successful installation.

2.1 Software Installation

In this section, users will learn how to install the software and drivers. As with proper installation of many USB devices, the Logic Analyzer application and driver software must be installed prior to the connection of the hardware. The following steps illustrate an installation of a AKIP Logic Analyzer. The other three models mentioned in Chapter 1 would follow identical procedures.

- Step 1.** Insert the driver CD-ROM in the PC CD drive.
- Step 2.** Execute the installation program. Go to the START menu, click **START**, **Run**, **Browse** in sequence, select **Setup.exe** file in the appropriate model folder and then click **OK**. It is recommended that all other programs are closed while the installation proceeds.
- Step 3.** Choose the **Application Setup**.
- Step 4.** Click **Next** to proceed with the Install Wizard.
- Step 5.** Select "**I accept the terms of the license agreement**", and click **Next**.
- Step 6.** Enter User and Company names.
- Step 7.** Choose the setup type. We recommend **Complete** for most users.
- Step 8.** Click **Install** to confirm settings and begin the actual installation.
- Step 9.** Click **Finish** to complete the installation.



Logic Analyzer

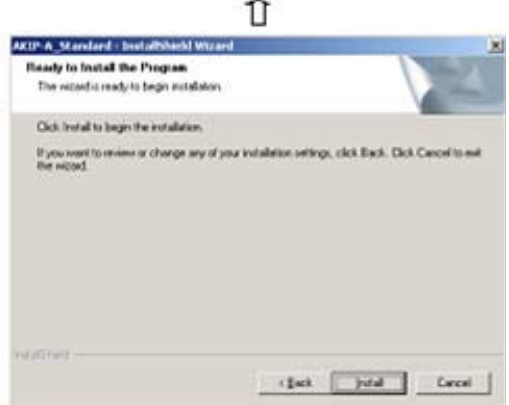
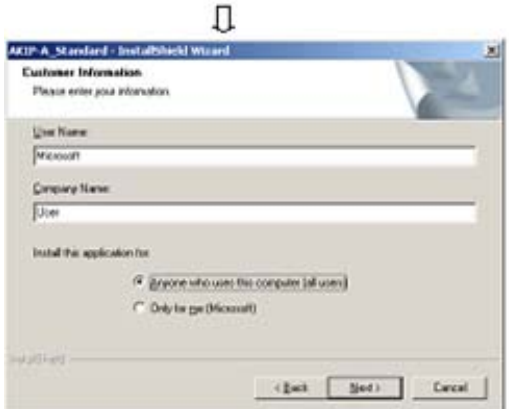

2.2 Hardware Installation

Hardware installation simply involves in connecting the Logic Analyzer to your computer with the included USB Cable as shown in Figures 2-4 and 2-5.



Fig. 2-1

1. Plug the fixed end of the cables into the LA (Fig. 2-1).

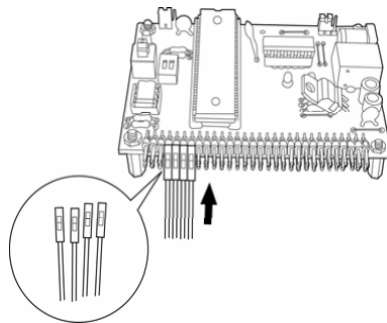

Fig. 2-2

2. Plug the loose ends into the connectors on the circuit board to be analyzed (Fig. 2-2).

Note: The following sequence must be observed when connecting the connectors into the circuit board: A0 = Brown, A1 = Red, A2 = Orange, A3 = Yellow, A4 = Green, A5 = Blue, A6 = Purple and A7 = Gray.



Fig. 2-3

3. The circuit board must be grounded to the Logic Analyzer with the black Ground Cable (Fig. 2-3).



Fig. 2-4

4. Plug the square end of the USB cable into the Logic Analyzer (Fig. 2-4).

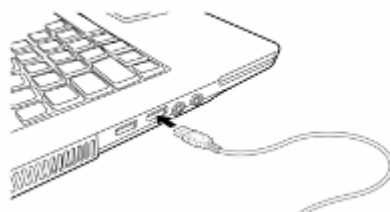

Fig. 2-5

5. Plug the thin end into the computer (Fig. 2-5).

At this point, the computer should be able to detect the Logic Analyzer and finalize the installation for hardware connection. For further information, refer to the Troubleshooting and the Frequently Asked Questions (FAQ) chapters in the User Manual.



Fig. 2-6: An Assembly of Laptop, Logic Analyzer and Testing Board

2.3 Tips and Advice

1. When testing a circuit board, make sure that the internal sampling frequency (within the Logic Analyzer) is at least four times higher than the external board frequency.
2. If the signal connector does not work well with the pins on the test board, try to use the supplied probes.

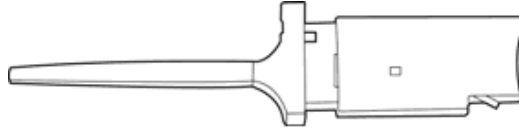

Fig. 2-7: Probes supplied with AKIP Logic Analyzer

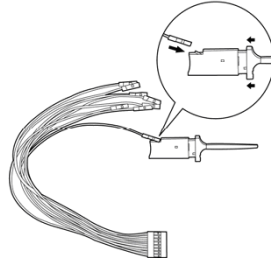

Fig. 2-8

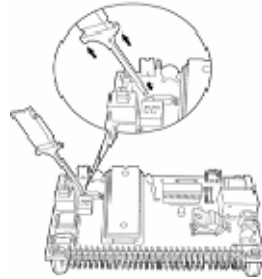

Fig.2-9

3. Usages of probes

3-1. Take the loose end of the cable and insert it into the clip (Fig. 2-8).

3-2. Compress the probe as shown to reveal two metal prongs (Fig. 2-8).

3-3. Place the metal prongs on a metal connector on the testing board and release the fingers so that the prongs can grip the metal connector (Fig. 2-9).

4. Unwanted signals can be filtered out by using the **Signal Filter** or **Filter Delay** function.
5. During the long-time measuring, **Compression** makes memory work more efficiently.
6. Trigger condition depends on the testing board. If triggering does not work well, try to narrow the trigger conditions and optimize them repeatedly.
7. If the testing board's frequency is lower than that of Logic Analyzer, user shall sample signals according to the external clock.
8. When the external clock is used for sampling, users could filter extra signals with the Signal Filter function.
9. Unused channels could be removed from the Bus/Signal column in the dialog box of Channels Setup (on the popup menu of g Bus/Signal column).

3 User Interface

- 3.1 Menu & Tool Bars
- 3.2 Find Data Value
- 3.3 Statistics Feature
- 3.4 Customize Interface
- 3.5 Auto Save
- 3.6 Color Setting
- 3.7 The Flow of Software Operation

Objective

Chapter 3 presents detailed information on the Logic Analyzer software interface in four sections: **Menu Bar**, **Tool Bar**, **Statistical Function** and **Interface Customization**.

Basic Layout

The layout of the Logic Analyzer software interface can be divided into nine sections as shown in the following figure.

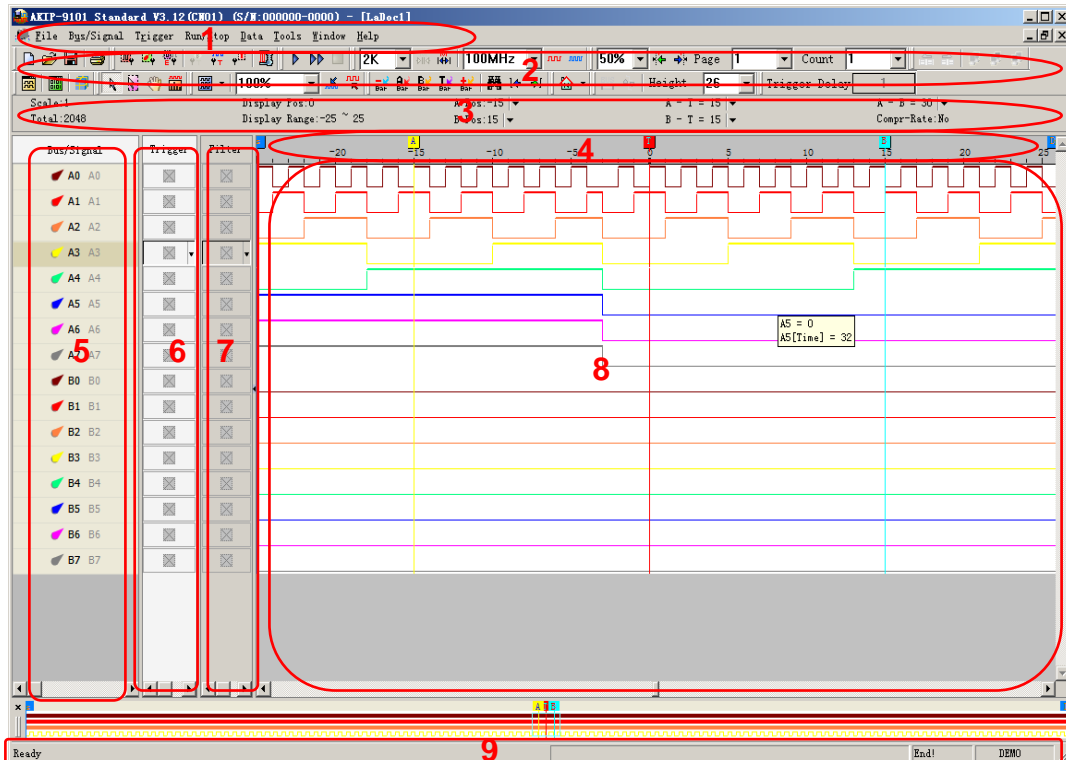

Fig 3-1: Software Interface

1. Menu Bar

All operations are performed directly from the menu bar, including **configure label**, **rename**, **execute** and **stop**. Pull-down menus allow easy navigation through the measurement panel.

2. Tool Bar

The tool bar is the graphical user interface which can make you work with some of the more common applications. From these icons, you can change settings and operate the Logic Analyzer easily.

Note: The prompting information of the shortcut keys has been added in the tooltips of the Tool Bar, that is to say, when users place the cursor on the icons, the corresponding shortcut key information will appear. For example, the prompting information of the New button is "New (Ctrl+N)". "Ctrl+N" is the Shortcut Key of the function of New.

3. Information Bar

The Information Bar displays information about the grids in the waveform, such as: Address, Time, Frequency, Trigger Bar, A Bar, B Bar and other Bar. Details of the labels are below:

Scale - Define the acquisition clock that controls the data sampling

Total - The period of time when Logic Analyzer captures data.

Display Pos - The middle tip means the middle position of the waveform.

Display Range-Display the waveform time range of the current waveform display area.

A Pos - The main function is to set A Bar or the other Bar.

B Pos - The main function is to set B Bar or the other Bar.

A-B - Press the under arrow to exchange and become the other Bar
Moreover, you also can execute this function from the other Bar.

4. Ruler (Waveform Display / Listing Display)

Ruler shows the time position of the waveform shown in the waveform display area or the listing display area.

5. Bus/Signal (Waveform Display / Listing Display)

Edit names of the measured channels; color shown matches the trace color.

6. Trigger Column

Trigger Column allows users to adjust signal trigger conditions.

7. Filter Column



Filter Column allows users to set Bus or signal filter conditions.

8. Display Area

Acquired data is displayed as a waveform or in a list format.

Waveform Display

This interface shows the digital signals. When the signal is logic "0", the waveform will be displayed as .

If the signal is logic "1", the waveform is as . An unknown signal waveform is displayed in gray between the high and low levels as . There are sixteen channels in AKIP-9101, and thirty-two channels in AKIP-9102, AKIP-9103 and AKIP-9103/1.

Listing Display

This interface shows the digital signals as 1 and 0. Logic 1 is displayed as "1" and logic 0 is displayed as "0".

9. Status Area

Display the Logic Analyzer status. The function name is also indicated here.

3.1 Menu & Tool Bars

Section 3.1 presents detailed information on the eight menu and fourteen tool items shown in the menu bar. The eight menu items are **File**, **Bus/Signal**, **Trigger**, **Run/Stop**, **Data**, **Tools**, **Window** and **Help**. The fourteen tool items are **Standard**, **Trigger**, **Run/Stop**, **Sampling**, **Trigger Content Set**, **Display Mode**, **Windows**, **Mouse Pattern**, **Zoom**, **Data**, **Height**, **Trigger Delay**, **Font Size** and **Data Contrast /Screen Display**.

File

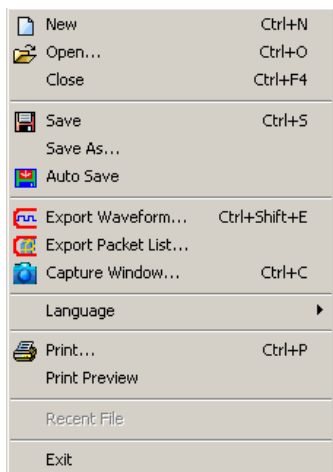

Fig 3-2: File menu.

- ← **Close** - Close the file being worked on.
- ← **Auto Save**—Save the required file automatically. (See Section 3.5 for detailed instructions)
- ← **Export Waveform**—Export files into Text (*.txt) and CSV Files (*.csv)
- ← **Export Packet List** – Export the active packet list.
- ← **Language**—Allow users to change the language interface of menus, tool boxes, etc.
- ← **Print Preview**—Show three options: Bus/ Signal & Trigger & Filter, Position Display Area and Waveform Display Area (See Fig. 3-17).
- ← **Exit** – Exit the program.

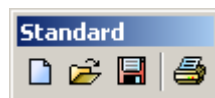



Fig 3-3: File Tool Box

Menu Bar: File

Menu Item	Detail Menu & Dialog Box
	Open a New file.

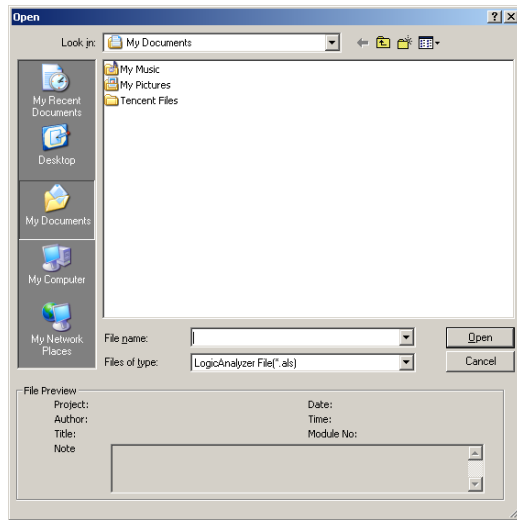

Fig 3-4: **Open** an existing file.

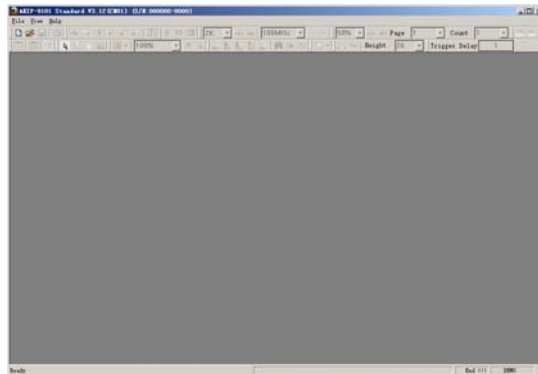

Fig 3-5: **Close** the active workspace.

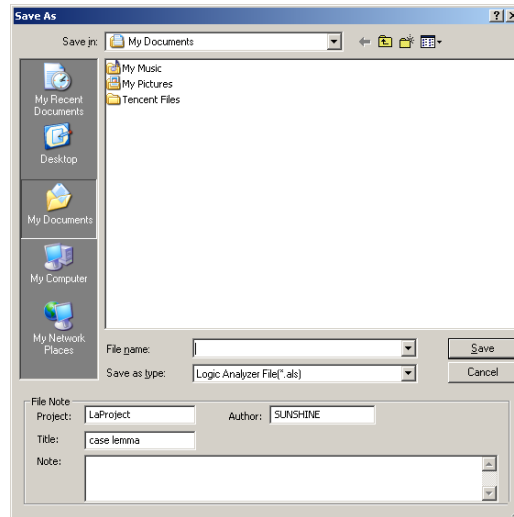

Fig 3-6: Save As Dialog Box

Save – Save the current file.

Save As – Specify the name of the file to be saved.

Auto Save – Save the required file automatically.

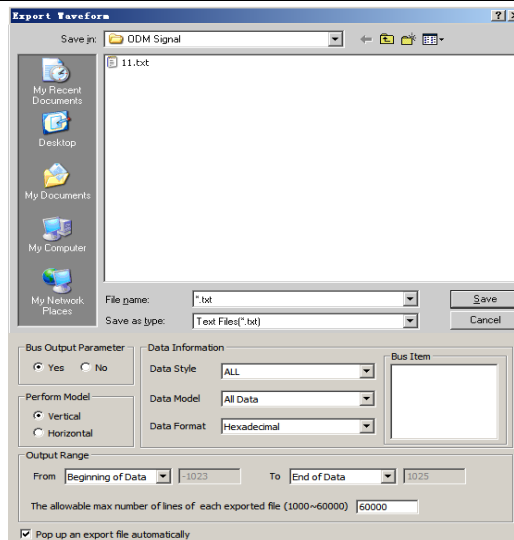

Fig 3-7: Export Waveform Dialog Box

Export Waveform: Export a file into text (*.txt) or CSV (*.csv) formats.

Bus Output Parameter: Decide whether or not to display the parameters of the file to be exported.

Perform Model: Choose whether to export the data either vertical or horizontal.

Data Style: Include ALL, ALL BUS, PROTOCOL (HAS CHANNELS), PROTOCOL(NO CHANNELS).

Data Model: Export data changed function; the selected items include ALL Data, Sampling Changed Dot (Compression), Data Changed Dot (Compression). Some of the data value for the signal channels of sampling position are the same, for example, view the data changed and decrease export capacity; this function will be good for users.

Output Range: Choose the range of the data to export from the pull-down menus.

The allowable max number of lines of each exported file (1000-60000): After activated, users can self-define the display row number of the exported file (1000-60000).

Pop up an export file automatically: The export file can be popped up automatically. Users can decide whether to activate the function; the default is selected. See the export file below:

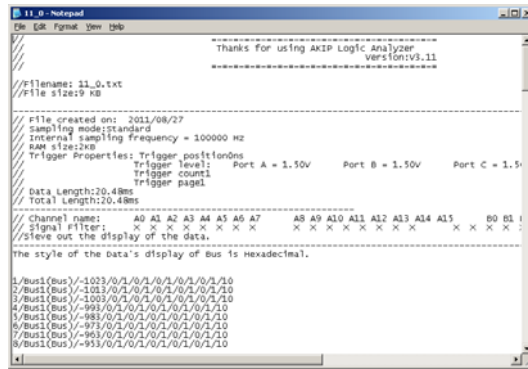
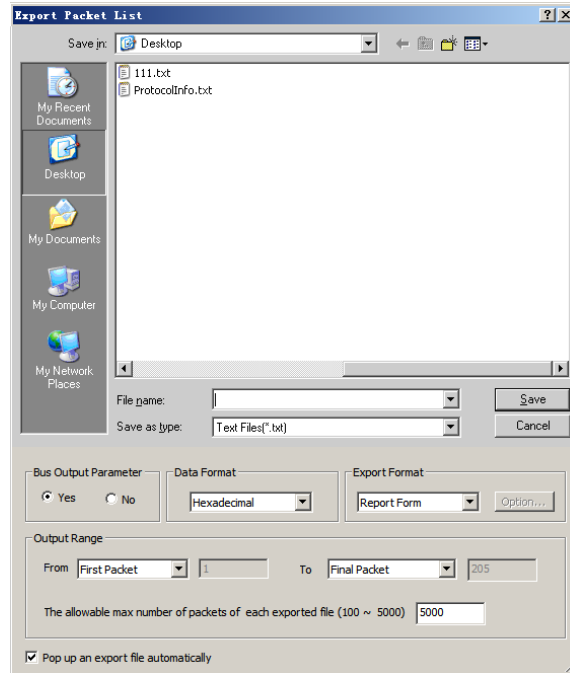

Fig 3-8: Export File



Export Packet List...

Fig 3-9: Export Packet List Dialog Box

Users can use paperwork, register and analyze packet list data.

The allowable max number of packets of each exported file (1000-5000): After activated, users can self-define the display packet number of the exported file (1000-5000).

Pop up an export file automatically: The function of popping up an export file automatically in the Export Packet List dialog box is the same with that of the Export Waveform dialog box.

Export Format: The Export Format is convenient for users to use the captured data in the following process. There are two formats for selecting, Report Form and Pure Data Form. See the following picture:

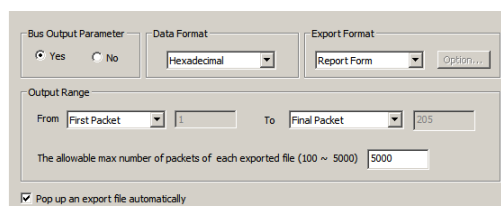

Fig 3-10: Export Format Pull-down Menu

In the part of the Export Format, when the users select the Report Form, the “Option” button can’t be used; when users select the Pure Data Form, the “Option” button can be used. The “Option” pops up the Option dialog box as follows, where users can customize the export data items in the dialog box which are Packet #, Name, TimeStamp, Length and DESCRIBE.

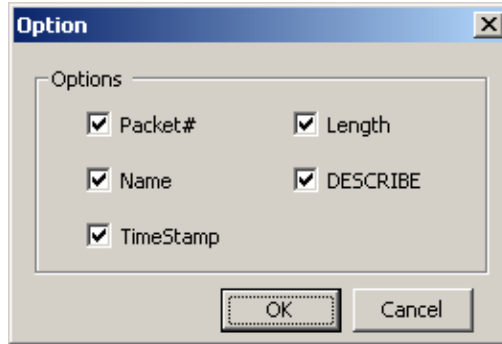

Fig 3-11: Option Dialog Box

For instance, all the export options are selected entirely.

See the below picture:

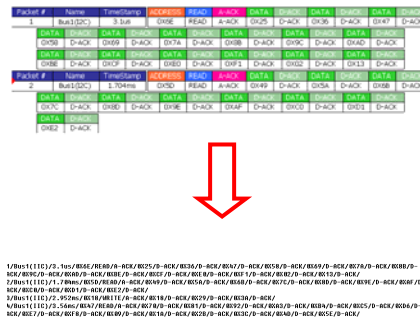

Fig 3-12: Pure Data Form

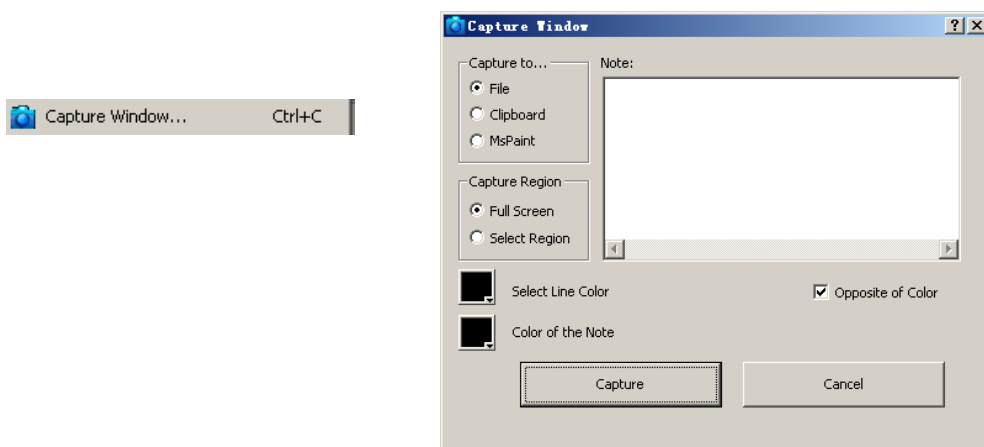

Fig 3-13: Capture Window

This feature is equivalent to [Alt]+[Print Screen], or [Print Screen]

Capture to

File – Save the captured image as either a jpeg or bmp.
Clipboard – Copy the captured image to the clipboard for use in other applications.
MsPaint – Directly start MsPaint to view the captured image.

Capture Region

Full Screen – Capture everything on the screen.
Select Region – After pressing the capture button, a cross-hair will appear on the screen. Left click the mouse button to drag an area to capture.

Select Line Color – Click the color box to change the color.

Opposite of Color – Click this check box to ensure that the note text will be the opposite of the line color.

Color of the Note– Choose the color of the note text.

Note – Type in a note to attach to the captured image.

Capture – Click the button to capture the image.

Cancel - Click the **Cancel** to end the capture.

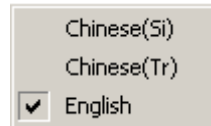

Fig 3-14: Choose among Chinese Simplified (Si), Chinese Traditional (Tr) and English.

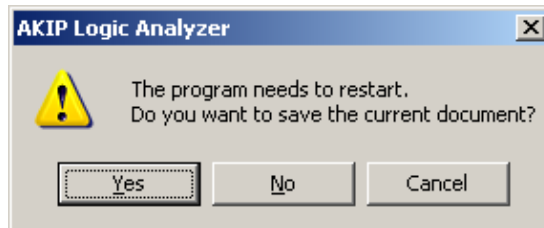

Fig 3-15: When changing languages, the above screen will be displayed and the program will need to be restarted.



Tip:

This function has been enhanced; now users can select the pages which they want to print or only the Current Page.

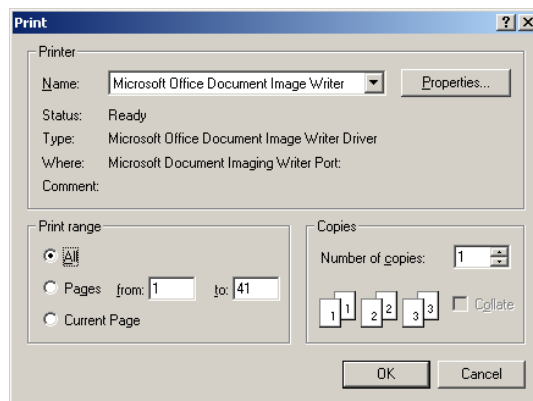

Fig 3-16: Click to enter the **Print** dialog box.

Print Preview

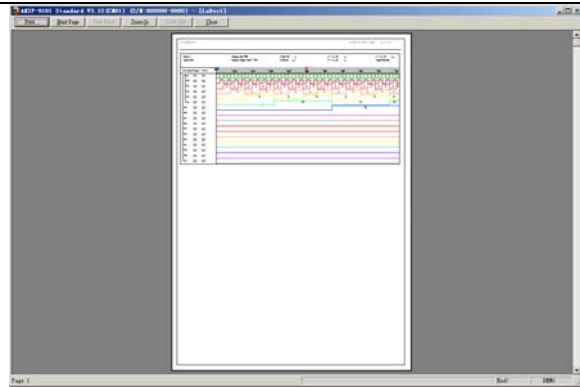

Fig 3-17: Click to show a **Preview** of the **Print**.

Recent File

Show the recently opened file.

Exit

Exit the program.

Bus/Signal

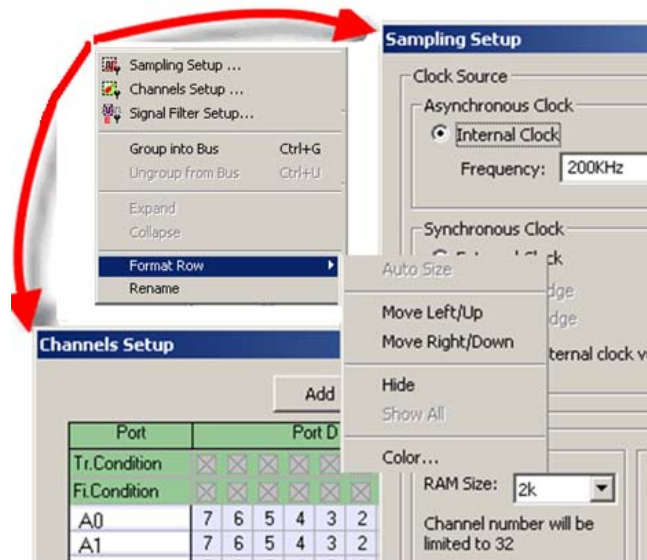

Fig 3-18: **Bus/Signal** Menu. Dialog boxes of the Sampling Setup and Channels Setup are shown and indicated by arrows.



Fig 3-19: **Trigger** Tool Box.

Menu Bar: **Bus/Signal**

Menu Item	Detail Menu & Dialog Box
-----------	--------------------------

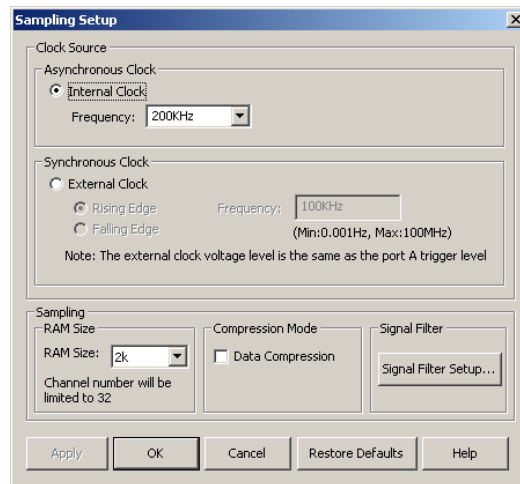
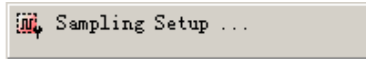

Fig 3-20: Sampling Setup

See Section 4.1 for detailed instructions.

Tip:

Icon	Description
	Decrease RAM Size
	Increase RAM Size
	Decrease Internal Clock Frequency
	Increase Internal Clock Frequency



Fig3-21: RAM Size

Choose the RAM Size and the internal clock frequency from the pull-down menus.

RAM Size

The amount of the acquired data that can be stored by the Logic Analyzer depends on the amount of the allocated RAM. The total depth of the memory for the AKIP Logic Analyzer is 128K Bits in each probe. If the Logic Analyzer starts gathering data with a 128K memory range, it will take a long time to find the required information. In order to avoid spending a lot of time gathering data, select a smaller RAM Size. The RAM Size options are 2K, 16K, 32K, 64K, 128K and 256K. So, if gathering data with 128K takes a long time why does 256K make sense? The reason for this extra RAM Size is to cope with the fact that a few of the 1~16 channels may have a large data input.

Tip:

Clock Source

Asynchronous Clock

Use the pull-down menu to choose the speed of the clock on the board being tested.

The sampling frequency should be more than four times higher than the signal to be measured so that the waveform duty cycle depiction will be accurate.

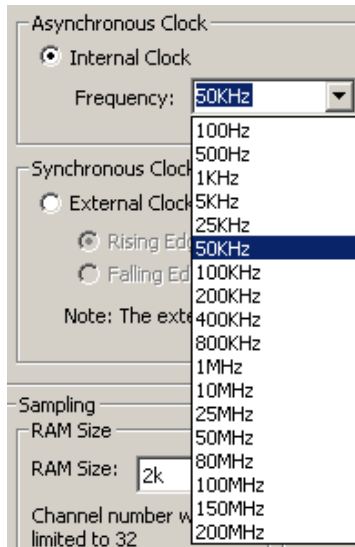

Synchronous Clock



Tip:



Compression

Choose the frequency of the clock on the board of the Logic Analyzer. Select “External Clock” to acquire data through external sampling. Choose either “Rising Edge” or “Falling Edge” to execute the analysis process.

According to the users input the value of external frequency in software, the software can count the relevant value about signal mode and frequency. For example: the value of the message, the time scale and the zoom in and out will be the value of time mode.

Connecting the Synchronous Clock

Use one of the single connecting cables to put one end on the testing board and the other in the LA as shown in the diagram opposite.

Check the box to compress all the data.

Compression is used to compress acquired data through a lossless compressor. The purpose of this compression is to place more data in a limited memory than in an actual memory. The compression rate of the Logic Analyzer can be up to 255 times. This means that the maximum acquisition can be 32M Bits (128Kx255= 32M Bits) for each channel. The chosen capacity of the memory, 1MB, means that the maximum data being sieved out arrives at 1MB*255=255M Bits (Per Channel).

Note: The rate will change depending on the data being analyzed.

Tip:



Signal Filter Setup

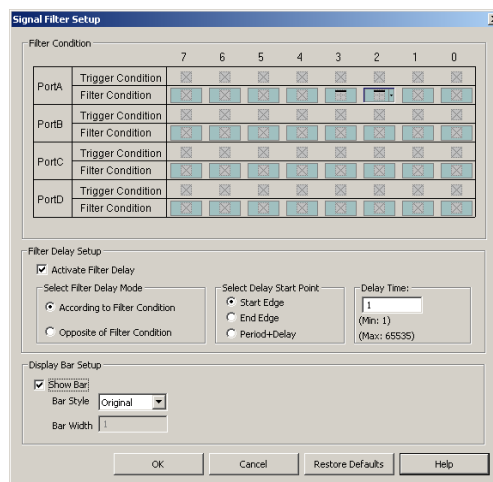



Fig 3-22: Signal Filter Setup Dialog Box

Tip:

Select the Signal Filter Setup from the pull-down menu of the Bus/Signal or click the  icon or the Button on the Sampling Setup dialog box to

The function of Signal Filter is to use an alterable judgment circuit which can filter undesired signals in order to capture and store valuable data in the memory. When the combination of input signals from each channel meets the

open the Signal Filter Setup dialog box.

Tip:

There are three modes of Signal Filter configuration for each channel.

filter conditions, the section of acquired data will be gathered by the Logic Analyzer and stored in the memory. After storing the data, it will return to the Logic Analyzer's system and be displayed as a waveform. If the combination does not meet the filter conditions, it won't gather and store data.

1.  = Don't Care means that the AKIP Logic Analyzer captures all signals from sampling.

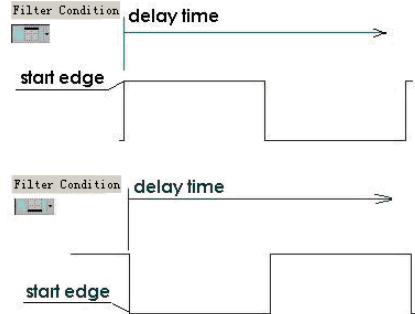



Fig 3-23: High and Low Levels

It is the system default.

2.  = High Level means that the AKIP Logic Analyzer captures and displays the input signals satisfying the high level.
3.  = Low Level means that the AKIP Logic Analyzer captures and displays the input signals satisfying the low level.

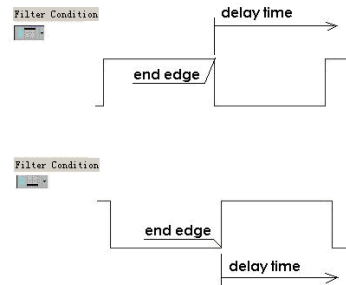
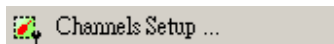

Fig 3-24: High and Low Levels

Signal Filter Delay Setup

Filter Delay – According to the filter condition.
Start Edge – Show the waveform from the start edge to the delay time interval.

See details in Section 4.1.



Tip:



Channels Setup

Tip:

- Add Bus/Signal
- Delete Bus/Signal
- Delete All
- Restore Defaults

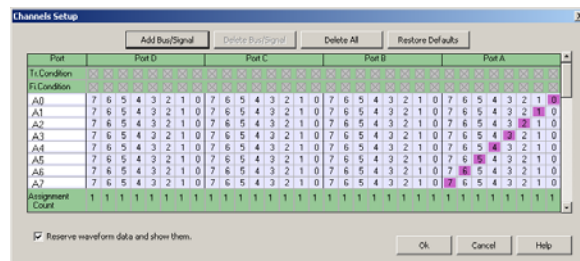

Fig 3-25: Channels Setup

See details in Section 4.2.

Click the **Add Bus/Signal** button to add a channel. This will appear as 'New0'.

Click the Bus or channel you want to delete and press the **Delete Bus/Signal** button.

Press the **Delete All** button to delete all the Buses and

channels.

Press **Restore Defaults** to return all channels and Buses to the system defaults.

Select this function when adding and deleting channels, the software reserves the original waveform; the waveforms in the channel are cleaned up when not selecting this function.

<p>Group into Bus Ctrl+G</p>	<p>Signals can be grouped into Buses by pressing Ctrl + G.</p>
<p>Reserve waveform data and show them</p>	<p>Signals can be added, deleted, copied and grouped into Bus, using the mouse or the keyboard, or right click and select the desired operations from the pull-down menu. The movement of a signal channel are Auto Size (not available in waveform display), Move Left/Up, Move Right/Down, Hide, Show All and Color)</p>
<p>Ungroup from Bus Ctrl+U</p>	<p>Ungroup signals from Buses by pressing Ctrl + U.</p>

A Bus contains at least 1 channel. In order to see these channels click the '+' symbol before the Bus name.

Expand

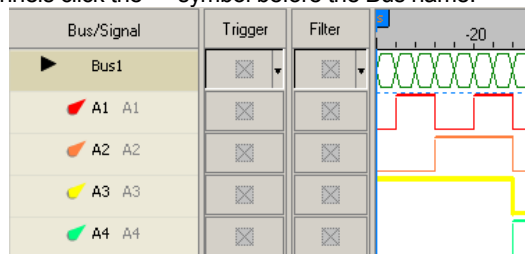

Fig 3-26: Expand

If the Bus has been expanded, click the '-' symbol before the Bus name to **Collapse** the Bus.

Collapse

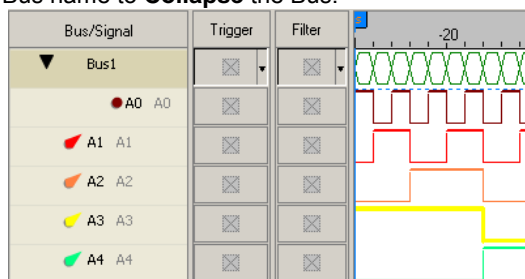

Fig 3-27: Collapse

Format Row

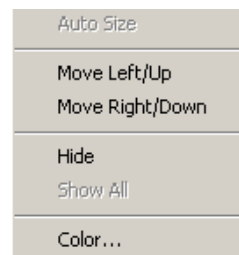

Fig 3-28: Click to change the Bus or signal display.

Tip:

- Format Row
- Auto Size (it is not available in Waveform Display mode)
- Move Left/Up (change to Move Left in Listing Display)

Change the display of a Bus or a signal.

Size the signal columns automatically.

Highlight a signal or Bus and click **Move Left/Up** to move the signal or Bus up (left) through the list of the Bus/signal.

Highlight a signal or Bus and click **Move Right/Down** to move the signal or Bus down (right) through the list of the

Move Right/Down (change to Move Right in Listing Display)	Bus/signal. Highlight a signal or Bus and click Hide to hide it. Click to show all signals and Buses that have been hidden.
Hide	
Show All	Highlight a signal or Bus and click Color to change the color.
Color	
	Highlight a signal or Bus and click Rename to rename the Bus or signal.

Trigger

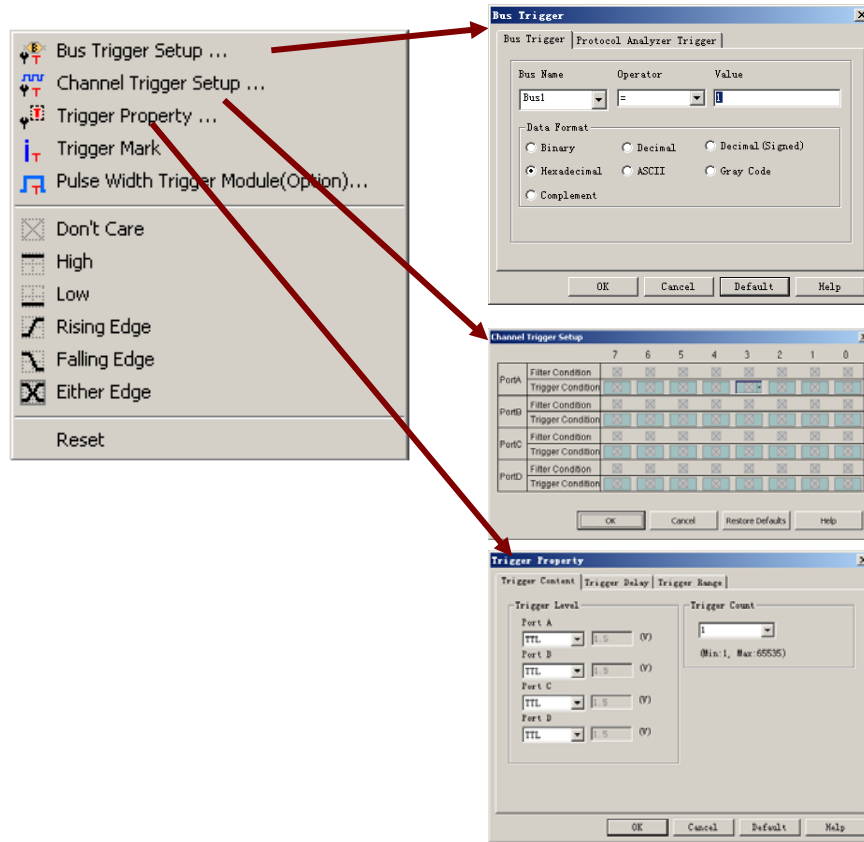

Fig 3-29: Trigger Menu



Fig 3-30: Trigger Tool Box

Menu Bar: Trigger

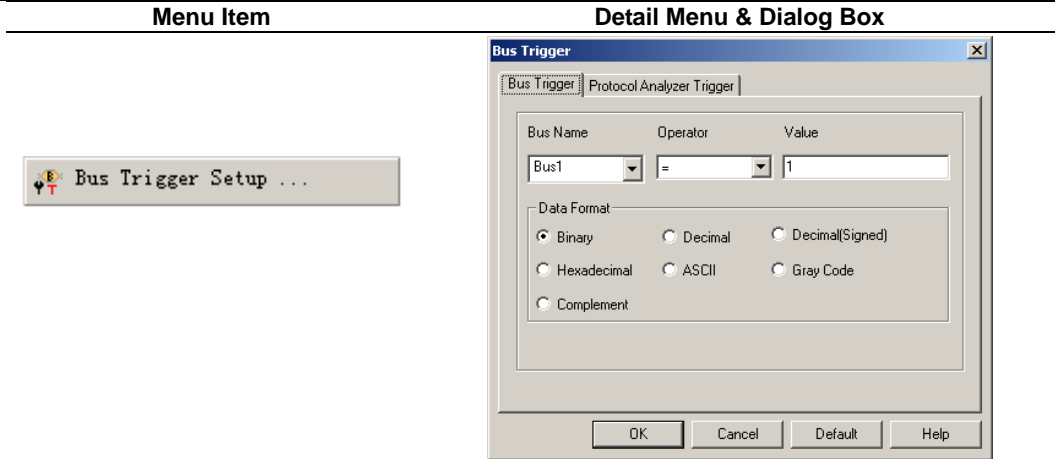

Fig 3-31: Set **Bus Trigger**

See Section 4.1 for detailed instructions.

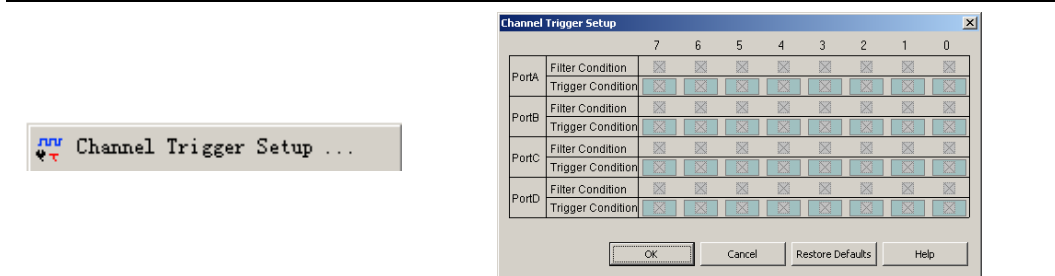

Fig 3-32: The trigger action tells the Logic Analyzer when to send data to the PC. The trigger conditions determine when the trigger point starts to record the information.

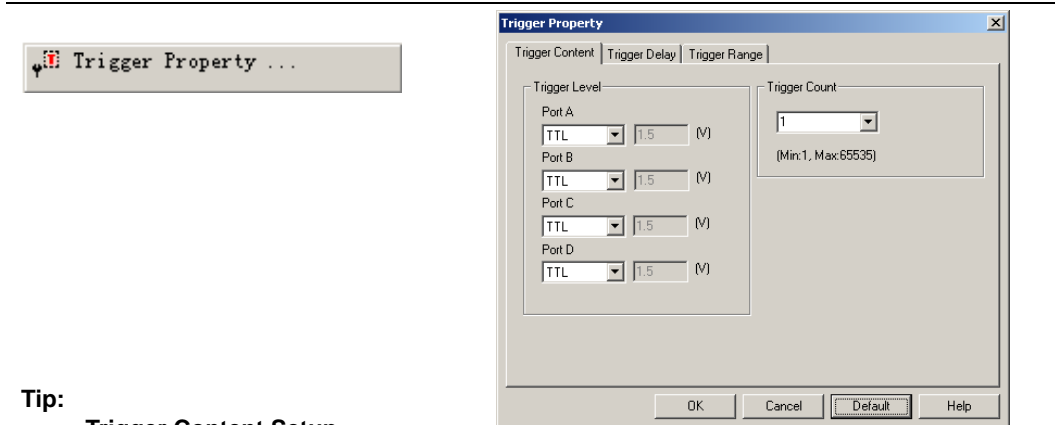



Fig 3-33: Set **Trigger Content**

See Section 4.1 for detailed instructions.

Tip:

Trigger Content Setup

Icon	Description
	Decrease trigger position
	Increase trigger position
N/A	Trigger Page
N/A	Trigger Count

Trigger Level

The voltage level that a trigger source signal must reach before the trigger circuit initiates a sweep. There are 4 ports available; each port has the ability to assign different voltages to meet users' requirements. Use the pull-down menu to choose between TTL (default TTL), CMOS (5V), CMOS (3.3V), ECL and User Defined (choose the value of the Trigger Level – 6.0V to 6.0 V).

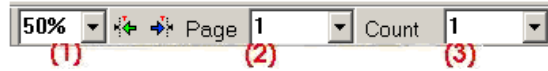

Fig 3-34: Trigger Position, Trigger Page, Trigger Count
(1) represents the Trigger Position of a memory page.
(2) represents the Trigger Page.
(3) represents the Trigger Count.

Tip:

Trigger Delay

Icon	Description
N/A	Trigger Delay

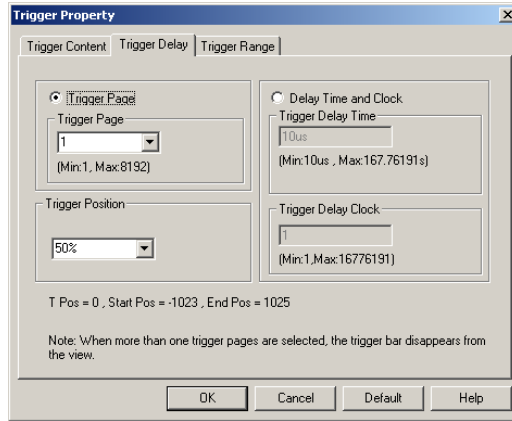

Fig 3-35: Set **Trigger Delay**

See Section 4.1 for detailed instructions.

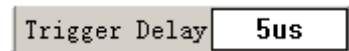

Fig 3-36: Set up **Trigger Delay** clock under time display.

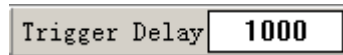

Fig 3-37: Set up **Trigger Delay** clock under sampling site display.

The **Trigger Delay** setting in the **Tool Box** equals to that in the above dialog box.

Tip:

Trigger Range

Icon	Description
N/A	Trigger Range

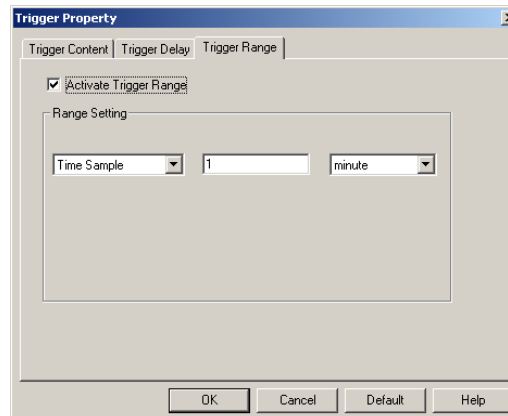
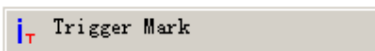
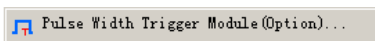

Fig 3-38: Set **Trigger Range**







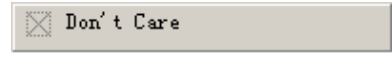
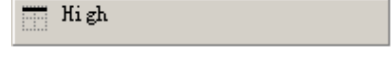

Open the Trigger Mark function.

See Section 4.1 for detailed instructions.



Pulse Width Trigger Module: Set a trigger condition for a single channel, and the signal in this channel can be

<p>Tip:</p> <p>It is not necessary to register as it can be used for free.</p>	<p>triggered in the predetermined range. However, this function is required to use with the hardware of the Pulse Width Trigger Module. (If you want to know about the detail, please refer to the Specification of the Pulse Width Trigger Module.)</p>
	<p>Set the trigger condition as "Don't Care". See Section 4.1 for detailed instructions.</p>
	<p>Set the trigger condition as "High". See Section 4.1 for detailed instructions.</p>
	<p>Set the trigger condition as "Low". See Section 4.1 for detailed instructions.</p>
	<p>Set the trigger condition as "Rising Edge". See Section 4.1 for detailed instructions.</p>
	<p>Set the trigger condition as "Falling Edge". See Section 4.1 for detailed instructions.</p>
	<p>Set the trigger condition as "Either Edge". See Section 4.1 for detailed instructions.</p>
	<p>Reset the trigger condition.</p>

Run/Stop

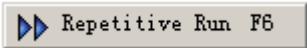
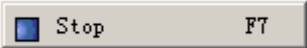

Fig 3-39: Run/Stop Menu



Fig 3-40: Run/Stop Tool Box

Menu Bar: Run/Stop

Menu Item	Detail Menu & Dialog Box
	Click to run once. See Section 4.1 for detailed instructions.
	Click to run continuously until the Stop button is clicked. See Section 4.1 for detailed instructions.
	Click to stop the repetitive run. See Section 4.1 for detailed instructions.

Data

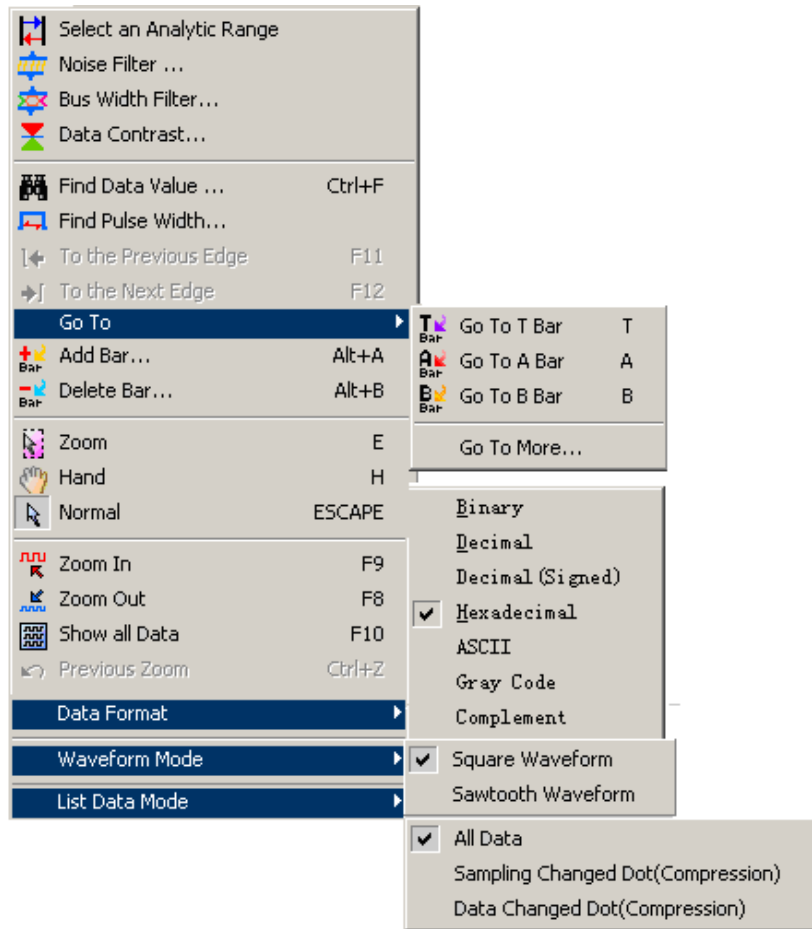



Fig 3-41: Data Menu



Fig 3-42: Data Tool Box

Menu Bar: Data

Menu Item	Detail Menu & Dialog Box
	Check the box to enable the Analytic Range to be changed by dragging the Ds and Dp bars with the left mouse button.

Noise Filter: It can filter 0~10 Clock's positive pulse width or negative pulse width signal.

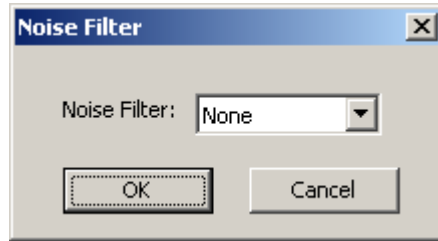

Fig3-43: Noise Filter

See Section 4.8 for detailed instructions.

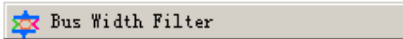
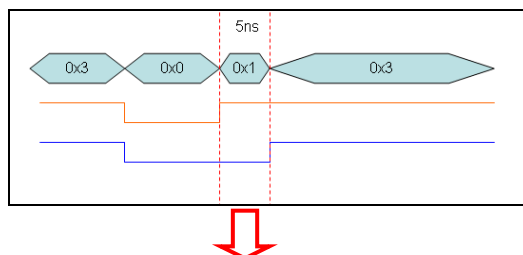

Fig3-44: Bus Width Filter

Select the check box to activate the function of the Bus Width Filter in the dialog box, and then users can input the corresponding value of the width to be filtered in the right edit box. Input the time value of the width when the display is in the Time Display or the Frequency Display, and the unit is based on time, such as s, ms, us, etc.; if the inputted value is out of the range, it will switch to the best time value among the range. Input the clock value of the width when the display is in the Sampling Site Display, and the range of the input is from 1 to 65535.

For example, after activating this function, and then input the value, 5ns. The Bus Data which is less than or equal to 5ns will be filtered as the figure below:



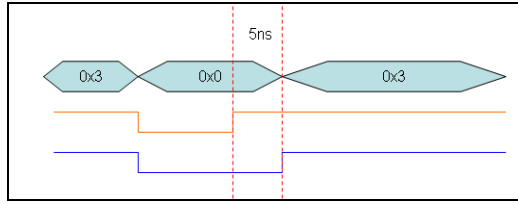

Fig3-45: Before and After Filtering

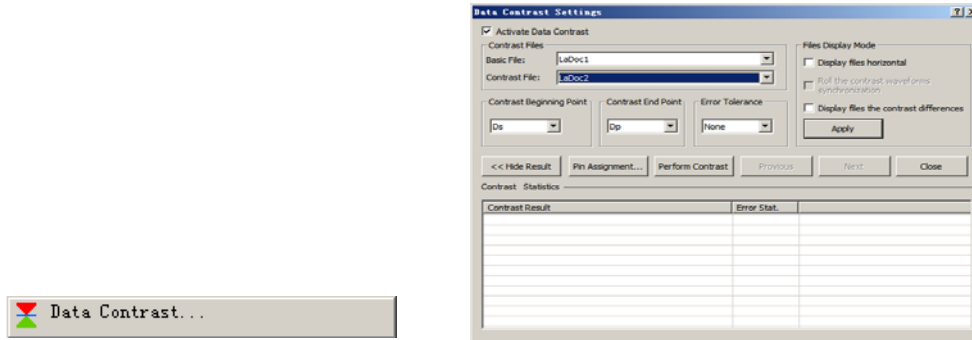

Fig3-46: Data Contrast

Data Contrast: It is used to contrast the difference for the two files of the same style. One is the Basic File, and the other is the Contrast File. The contrast can display the difference between the Basic File and the Contrast File.

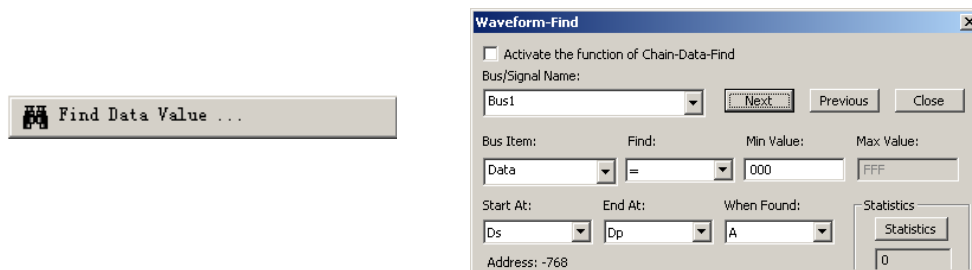

Fig 3-47: Waveform-Find Dialog Box without activating the Function of Chain-Data-Find

Use the pull-down menu to select the Bus/ Signal Name:

The list of Find depends on whether it is a Bus or Signal that is being searched in:

Bus – Choose among =, !=, In Range and Not In Range (enter the value for Min Value and Max Value).

Signal – Choose among Rising Edge, Falling Edge, Either Edge, High and Low.

Start At - Choose the position to start our search by selecting one of the following:

Ds, T, A, B, etc. (select from the pull-down menu).

Tip:

Remember the final conditions: When the find function is used, the function of displaying the final conditions is added. When you have closed the Waveform-Find dialog box, and you want to find the set conditions, you can open the Waveform-Find

dialog box again for the system has saved the last set conditions.

When Found - Choose A, B or other bars to mark the position where it is coincident with the set conditions.

Statistics – Show the number of instances of the search results.

Note: It is available only when searching through a Bus.

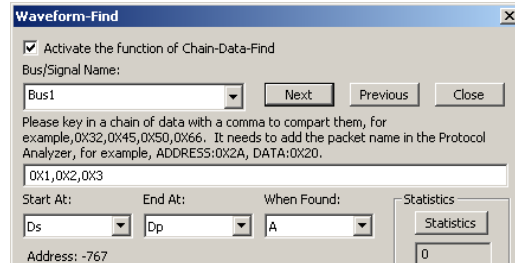
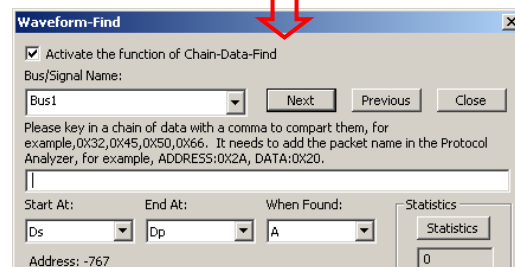
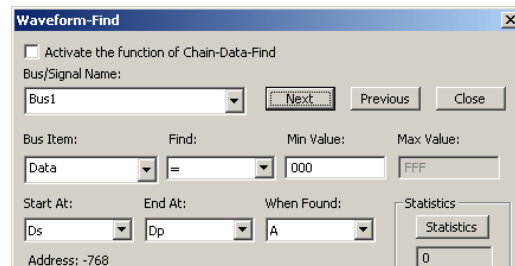

Fig3-48: Waveform-Find Dialog Box with Activating the Function of Chain-Data-Find

Tip:

The function of Chain-Data-Find is mainly for finding the data in the packets of Bus and Protocol Analyzer which have some serial data. For example, it can start finding with the serial packet segments (there are 0X1, 0X2 and 0X3) in the Bus. It improves the efficiency of Data Find. See the following process:



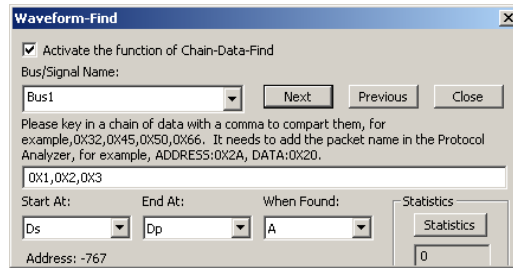

Fig 3-49: Process of Activating the Function of Chain-Data-Find

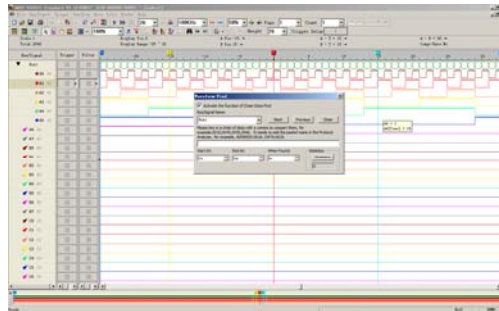

Fig3-50: Function of Chain-Data-Find Displayed on the Waveform Window

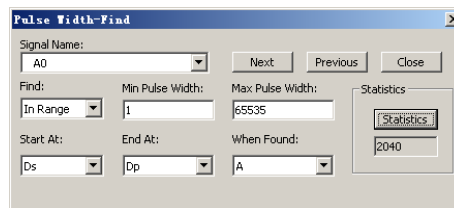
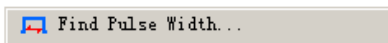

Fig3-51: Pulse Width-Find Dialog Box



Tip:

This function is mainly used for finding the pulse width in a single channel and the single channel of a Bus. It improves the efficiency of finding the Pulse Width for engineers and strengthens the Find function of the Logic Analyzer.

Signal Name: It can select the single channel for Find.

Find: It can select the Find conditions which are “In Range”, “Min Value”, “>”, “<” and “=”. When users select the option of “In Range”, they can input the value of the Min Pulse Width and Max Pulse Width between 1 and 65535 and find the Pulse Width in range. When users select the “Min Value”, they can find the Min Pulse Width for the present single channel. When users select the options “>”, “<” and “=”, they can input the value of the Pulse Width between 1 and 65535 and find the Pulse Width in range.

Start At: Select the Start point of Find. The selectable items are all Bars; the default is the Ds Bar.

End At: Select the End point of Find. The selectable items are all Bars; the default is the Dp Bar.

When Found: Select a Bar to mark the found Pulse

Width. The selectable items are all Bars; the default is A Bar.

Statistics: It can count the number of Pulse Width in the present range.

Next: It can find the next Pulse Width.

Previous: It can find the previous Pulse Width.

For example: Find in the A2 channel; the Pulse Width is equal to "40us"; take the A Bar as the mark. See the below figure:

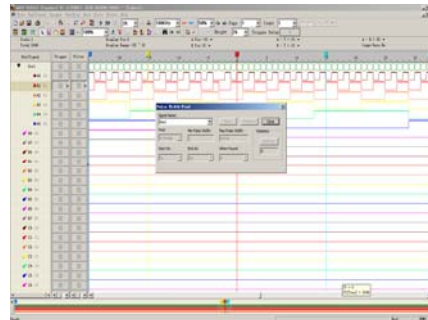
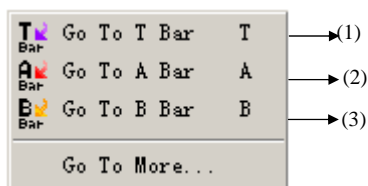

Fig 3-52: Pulse Width-Find on the Waveform Window

← To the Previous Edge F11	Go to the previous edge sweep of the indicated signal.
→ To the Next Edge F12	Go to the next edge sweep of the indicated signal.
Go To ▶	

Tip:



- (1) Press T, go to T Bar.
- (2) Press A, go to A Bar.
- (3) Press B, go to B Bar.

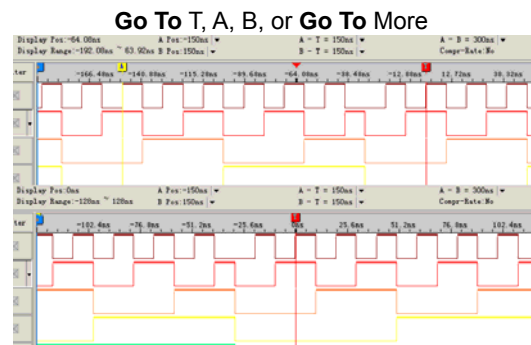

Fig 3-53: Go To T Bar; T Bar will be displayed in the center of the waveform area.

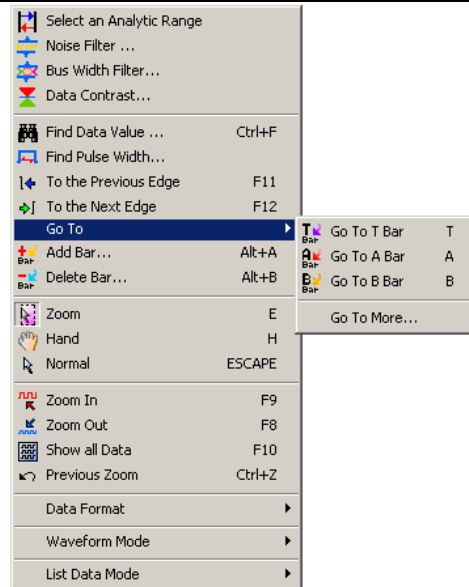
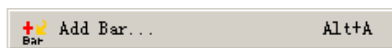

Fig 3-54: The selected bar will be shifted to the center of the waveform area.



Add user defined bars.

1. Click the above menu item from **Data** menu, or click **Add Bar** icon from **Tool Bar**.
2. Give a **Bar Name**, define a **Bar Color**, and set a **Bar Position**.
3. Define the **Bar Key** with the number between 0 and 9.

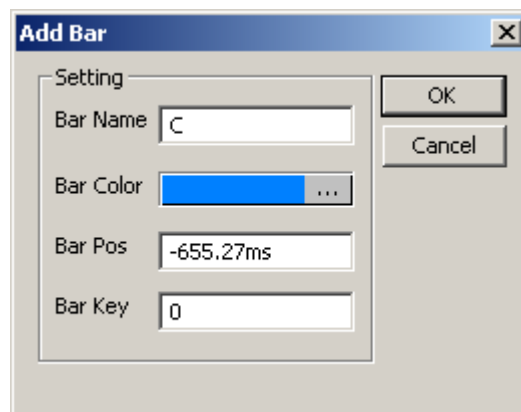

Fig3-55: Add Bar

Tip:

The number shortcut is set in the Add Bar dialog box. Every new bar can be filled in one number which is used to find the required bar faster; the default number of the new bar is 0. It is noticed that once the number key is set, it can't be modified, and each new bar can be named with the same number, that is to say, one number can name many bars.

For example, users can set the number 3 as the shortcut key. When users press the number 3 key, the C Bar will be displayed in the centre position of the screen.

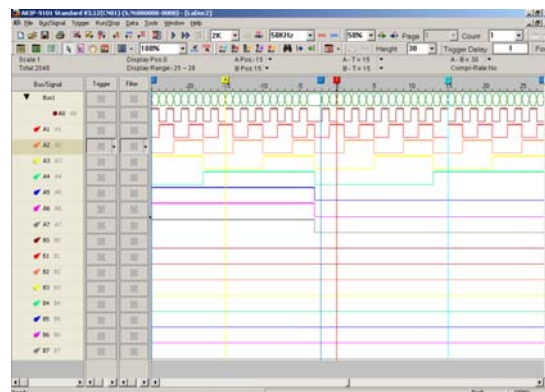
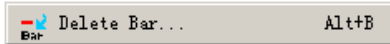

Fig3-56: Add a Bar with the number between 0 and 9



Delete a user defined bar.

1. Click the above menu item from **Data** menu, or click **Delete Bar** icon from **Tool Bar**.
2. Select a user defined bar, and click on **Delete**.
3. Delete the selected Bar with the **Delete** key on the **Keyboard**. Use the mouse to select the added bar and press the **Delete** key on the keyboard to delete the bar.

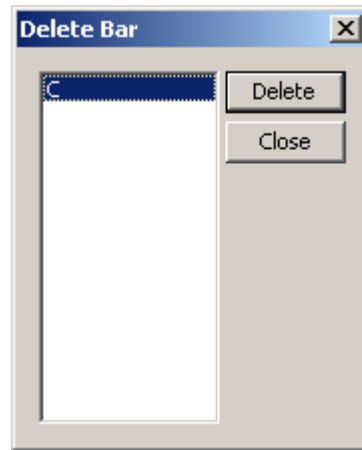

Fig3-57: Delete Bar Dialog Box

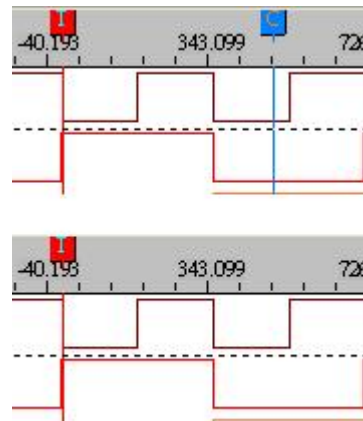
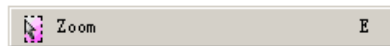

Fig 3-58: Delete a selected **Bar**.



Tip:

A Zoom-In or a Zoom-Out view will be centered in the Waveform Display Area, and the new zoomed view will be sized according to the available space on the display.

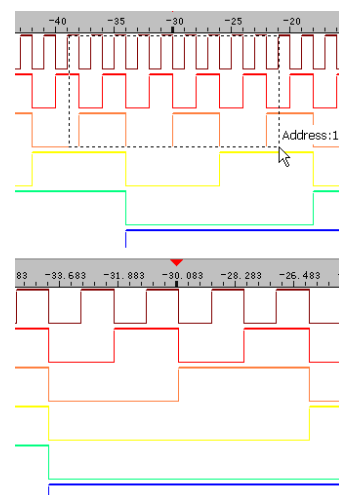

Fig 3-59: To **Zoom In**, left click and drag the mouse/point from left to right.

When users activate the **Zoom** to zoom in / zoom out the selected area, the Tooltip on the right corner of the bottom will display the Time, Clock or Address of the selected area. When selecting the Zoom function, and users are pressing and dragging the left key, the information on the right corner of the bottom will be changed and updated with the width of the selected area. And the information is displayed on the right corner of the bottom in the way of Tooltip. When users loosen the mouse, the information will disappear.

Tooltip:

Time/Frequency Sample: xxx (time)

/ns (unit)

Address: xxx (There is no unit with the address.)

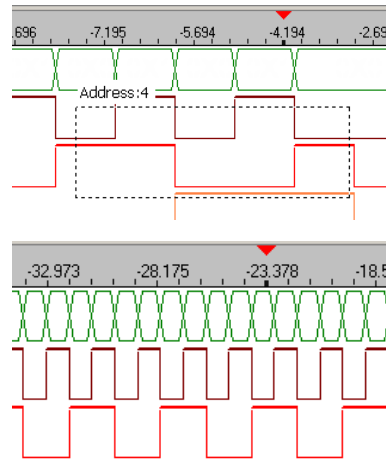

Fig 3-60: To **Zoom Out**, left click and drag the mouse/point from right to left.

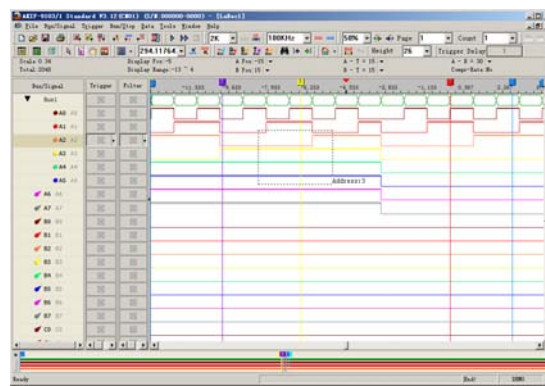

Fig 3-61: To display the Tooltip, left click and drag the mouse/point from right to left or from left to right.

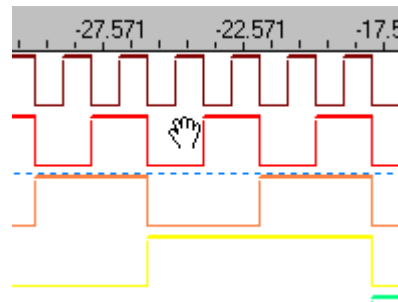
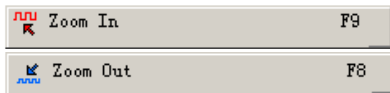

Fig 3-62: Click **Hand**, and then depress and hold the left key to drag.



Reset the mouse function to the system default.



Tip:

Zoom In and Out can be switched by changing the percentage value in the pull-down list.

1. The system can set the value of Zoom In and Out:

The default unit is μ s. When zooming in, it will be automatically changed to ns. When zooming out, it will be changed to ms, s or ks.

2. Pull-down Menu:

There are thirty scales.

The maximum zoom in and out is the cycle of each grid, 0.0001piece.

The minimum zoom in and out is the cycle of each grid, 1,000,000,000.

Zoom in and out (the proportion): with each grid being the cycle, the zoom in and out (%) is 100%. The time of Zoom In and Out counts by the clock of each grid (sample frequency). For example:

(1) Each grid is being a cycle; the zoom in and out is 100%. The time of Zoom In and Out will be presented by the clock of each grid X (1/sample frequency).

(2) Each grid stands for the clock of 100 pieces, the zoom in and out is 1% and the time of Zoom In and Out will be displayed by the cycle of each grid X (1/sample frequency).

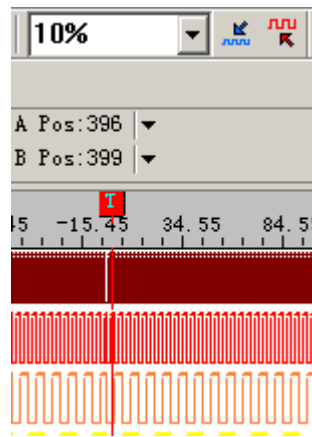

Fig 3-63: Normal Status

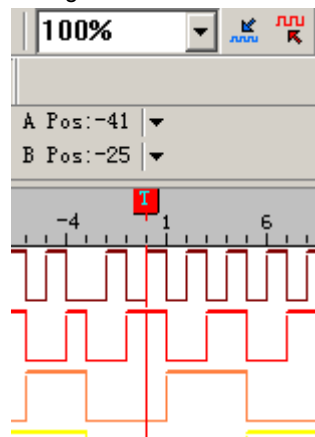

Fig 3-64: Result from Normal to Zoom In

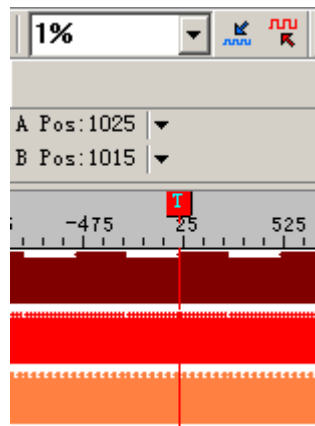

Fig 3-65: Result from Normal to Zoom Out

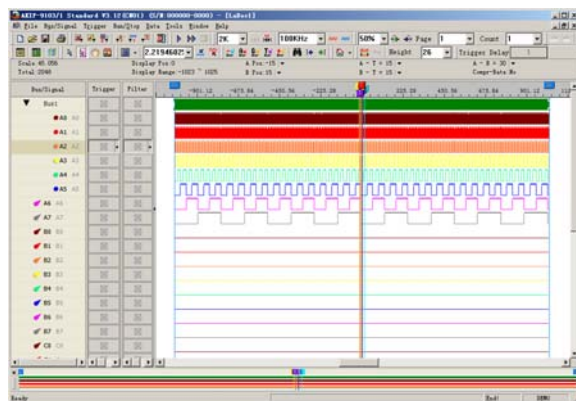
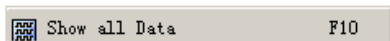

Fig 3-66: Show all Data

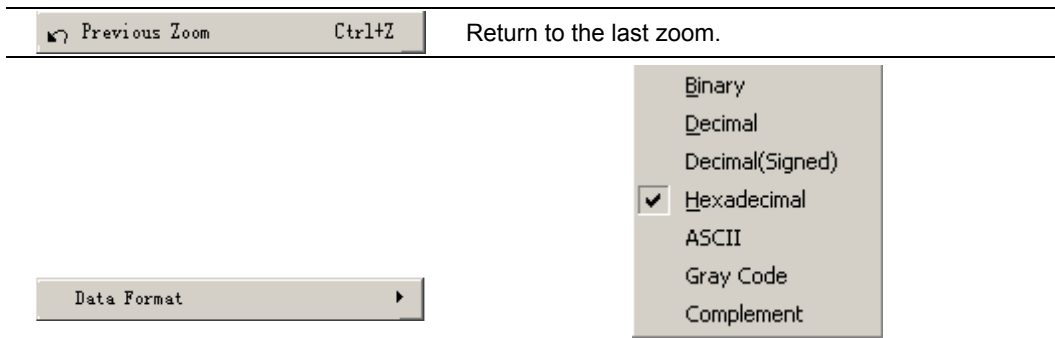

Fig3-67: Data Format

Show numerical information in Binary, Decimal, Decimal(Signed), Hexadecimal, ASCII, Gray Code or Complement format.

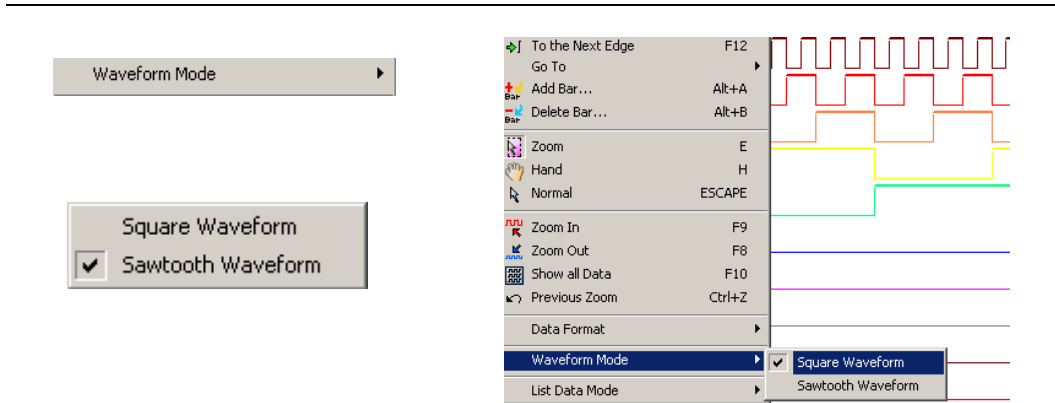

Fig 3-68: Square Waveform

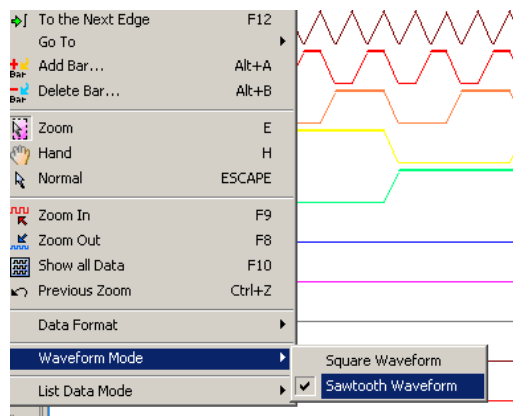
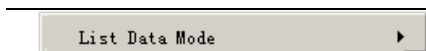

Fig 3-69: Sawtooth Waveform



Tip:

The data for list mode are so many, to be convenient for users, that there is adding a List Data Mode function. The formats for the List Data Mode are All Data, Sampling Changed Dot (Compression) and Data Changed

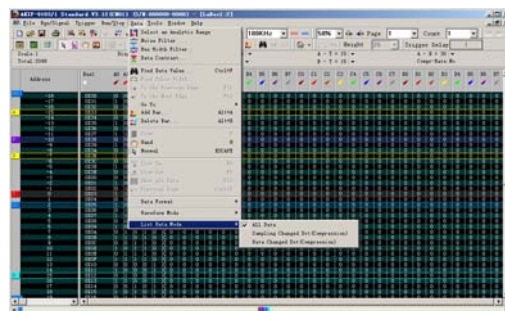

Fig 3-70: List Data Mode: All Data, Sampling

Dot (Compression). Changed Dot (Compression) and Data Changed Dot (Compression).
All Data: It is the present display mode.

Sampling Changed Dot

(Compression): Take the sampling changed dot as the compression data reference dot.

Data Changed Dot (Compression):

Take the present data change dot as the compression data reference dot.

Tools

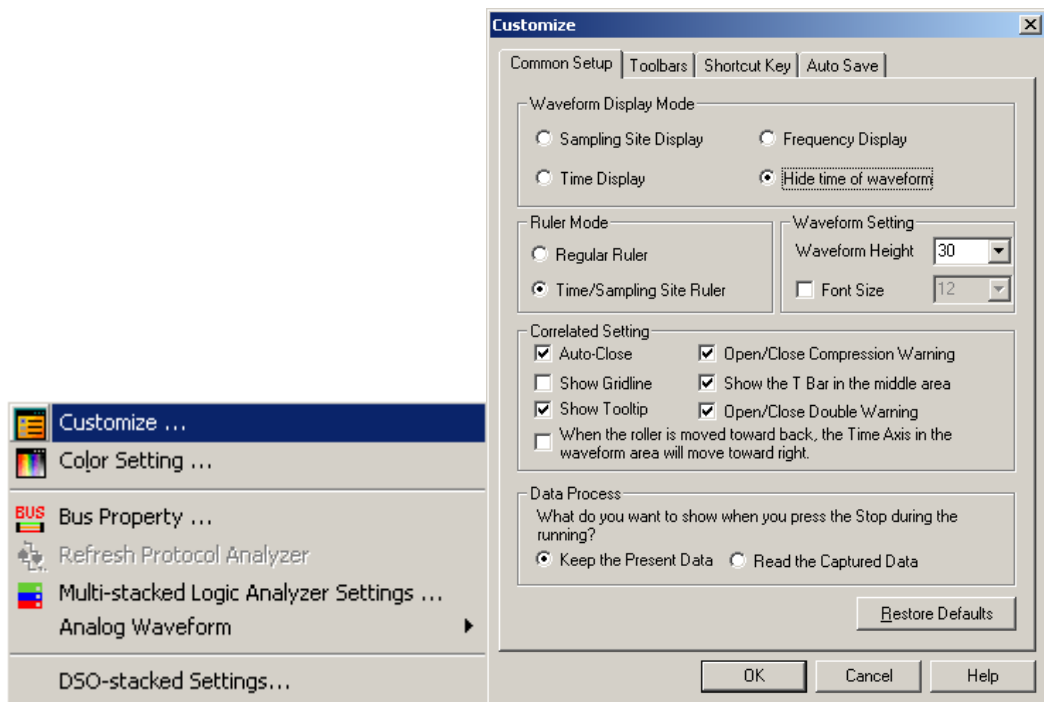

Fig 3-71: Tools Menu

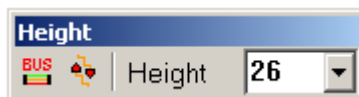

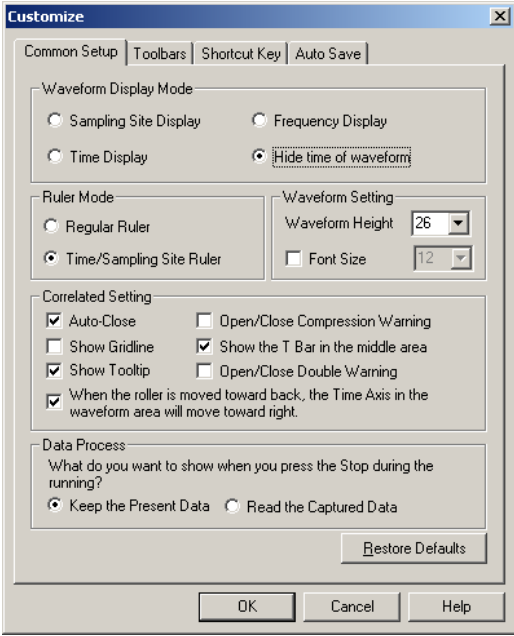
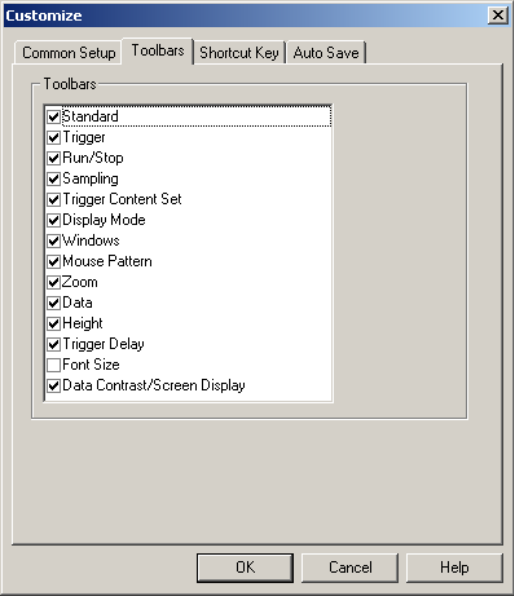

Fig 3-72: Tool Box

Menu Bar: Tools

Menu Item	Detail Menu & Dialog Box
	 <p>Fig 3-73: Customize Dialog box See Section 3.4 for detailed instructions.</p>  <p>Fig 3-74: Toolbars Setting</p>

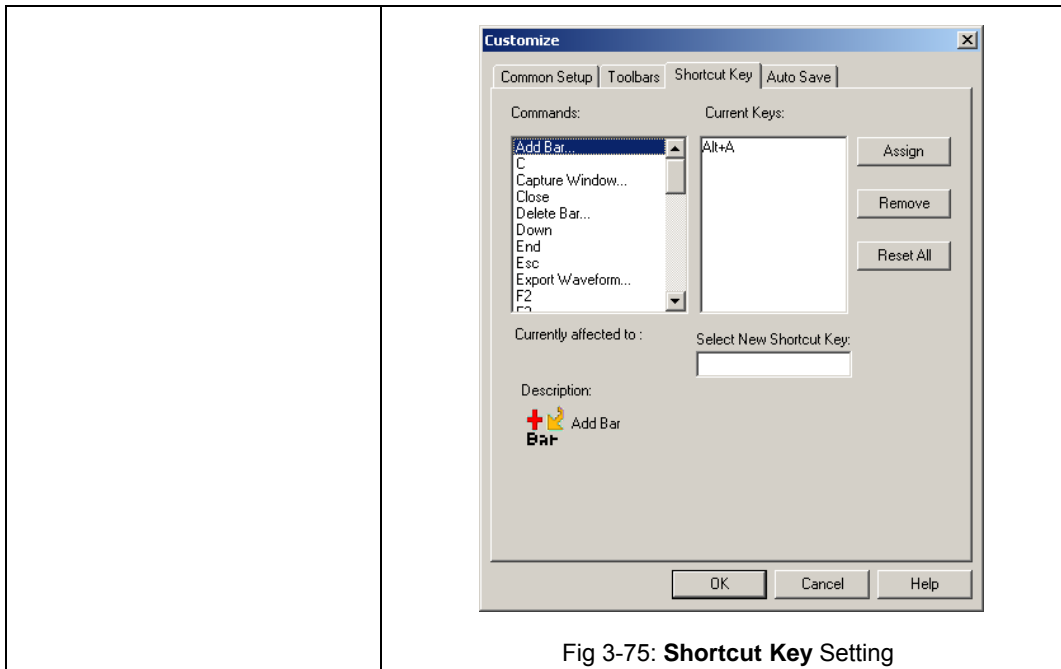

Fig 3-75: **Shortcut Key Setting**

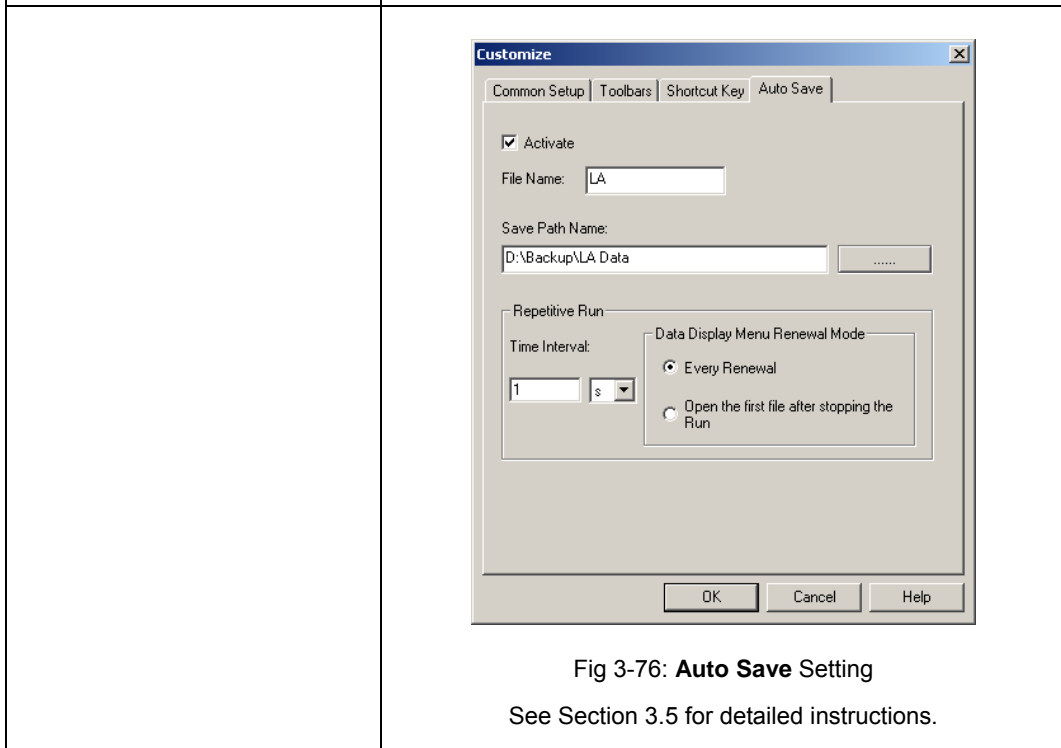

Fig 3-76: **Auto Save Setting**

See Section 3.5 for detailed instructions.

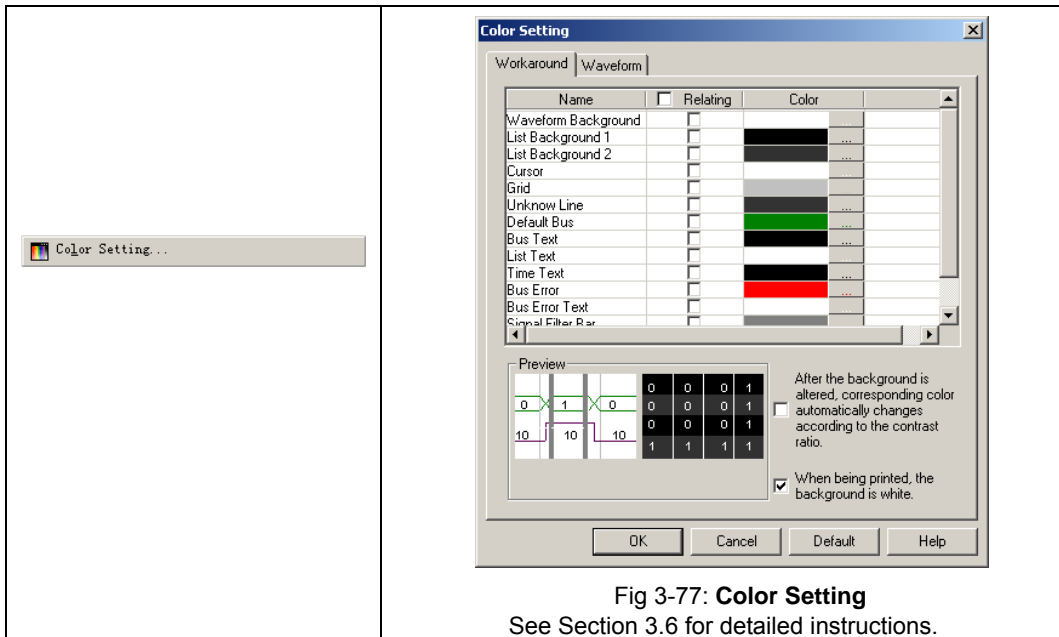

Fig 3-77: Color Setting

See Section 3.6 for detailed instructions.

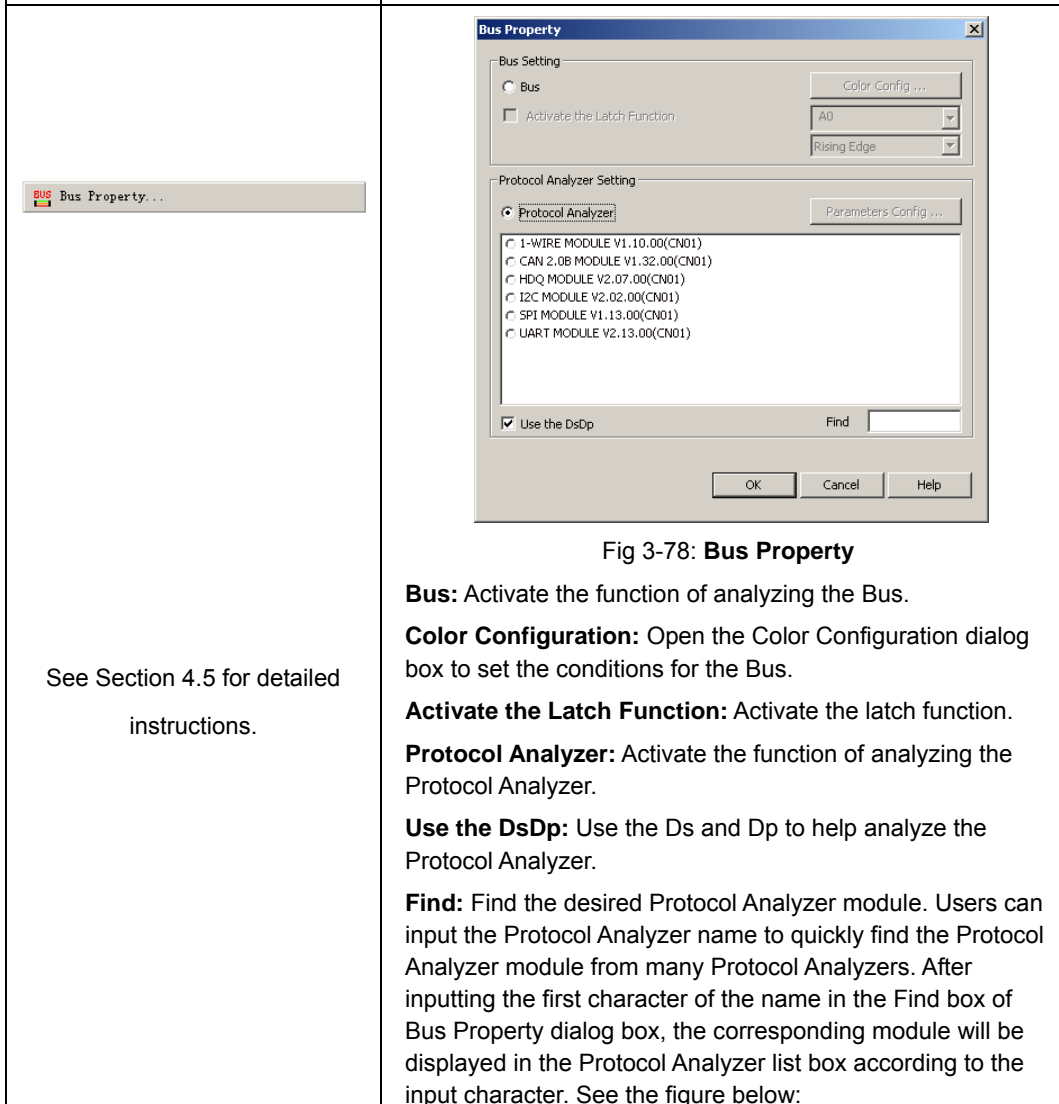

Fig 3-78: Bus Property

Bus: Activate the function of analyzing the Bus.

Color Configuration: Open the Color Configuration dialog box to set the conditions for the Bus.

Activate the Latch Function: Activate the latch function.

Protocol Analyzer: Activate the function of analyzing the Protocol Analyzer.

Use the DsDp: Use the Ds and Dp to help analyze the Protocol Analyzer.

Find: Find the desired Protocol Analyzer module. Users can input the Protocol Analyzer name to quickly find the Protocol Analyzer module from many Protocol Analyzers. After inputting the first character of the name in the Find box of Bus Property dialog box, the corresponding module will be displayed in the Protocol Analyzer list box according to the input character. See the figure below:

Color Setting ...

Bus Property ...

See Section 4.5 for detailed instructions.

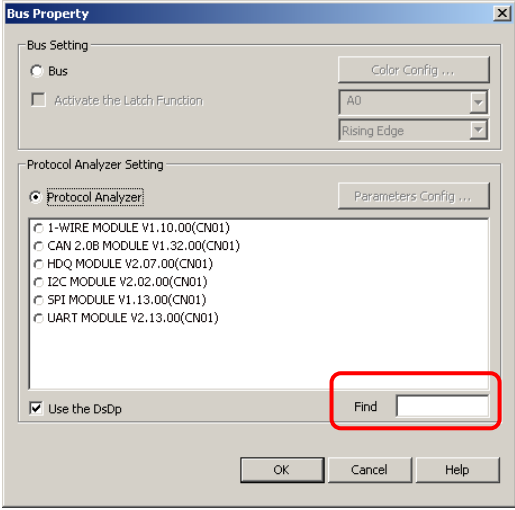
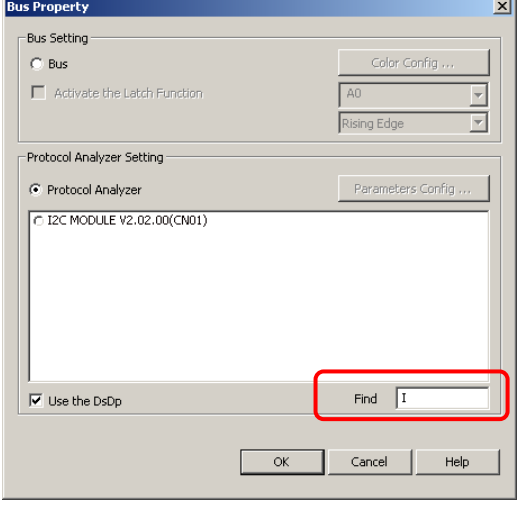
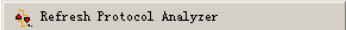
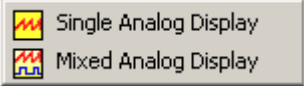
	 <p>Fig 3-79: Find Editor Box</p> <p>When you input "I" in the Find editor box, the Protocol Analyzer list displays all Protocol Analyzers with the initial character of "I"; see the below picture:</p>  <p>Fig 3-80: Find Result</p>
	<p>Refresh Protocol Analyzer data. See Section 4.10 for detailed instructions.</p>
<p>Analog Waveform</p>  <p>Tip: When the function of Analog Waveform is activated, the Analog Waveform will be displayed in the waveform area</p>	<p>Analog Waveform</p> <p>The function of Analog Waveform means that the Display Mode of Bus Data is not the Pure Data Mode, while it displays data change with the curve which looks like a waveform, in fact which is a curve to describe the data change. So it is called the Analog Waveform.</p> <p>The Analog Waveform can be divided into two kinds, namely, Single Analog Display and Mixed Analog Display, see the figures as below:</p>

of the Bus's sub-channel and take the space of four channels. And four sub-channels won't draw the waveform. It notes that the sub-channel of the Bus must be more than four channels.

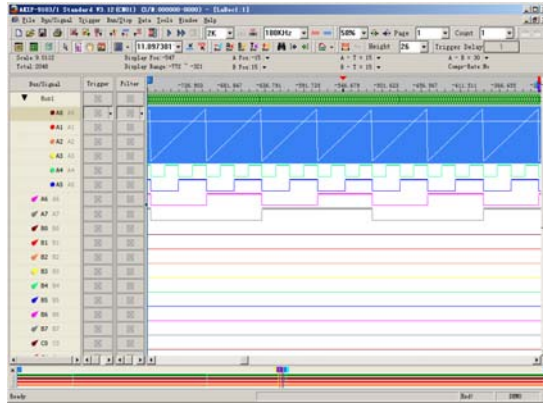

Fig 3-82: Single Analog Display

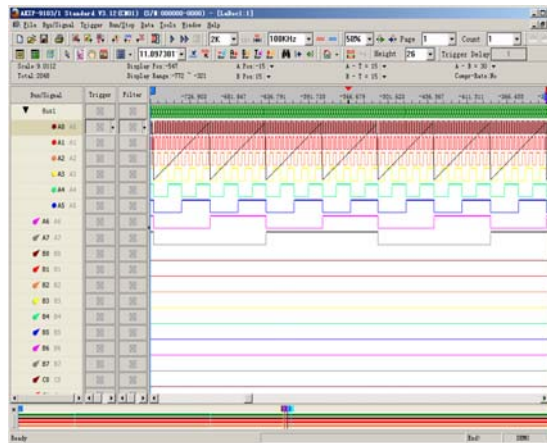
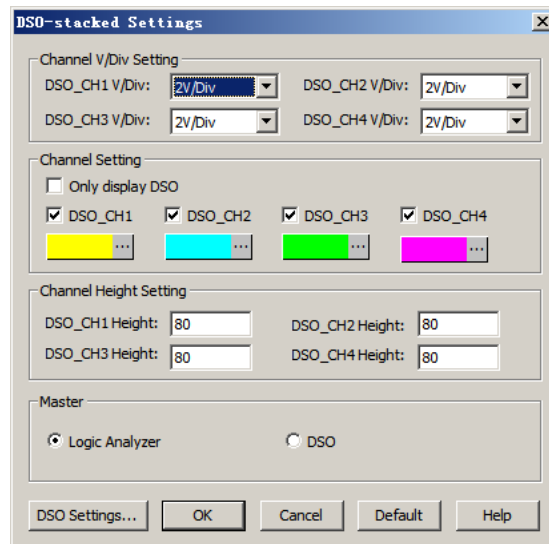

Fig 3-83: Mixed Analog Display

DSO-stacked Settings...



Channel V/Div Setting: Users can select the Options, 3V/Div, 2V/Div, 1V/Div, 500mV/Div, 200mV/Div, 100mV/Div, 50mV/Div, 20mV/Div, 5mV/Div and 2mV/Div.

Channel Setting: Users can set the DSO_CH1, DSO_CH2, DSO_CH3, DSO_CH4, the captured

waveform will be displayed on the LA Software; meanwhile, the color of CH can be changed. When selecting the item, Only display DSO, only the activated DSO CH can be displayed on the waveform. The A0~A7 can't be displayed, see as below figure.

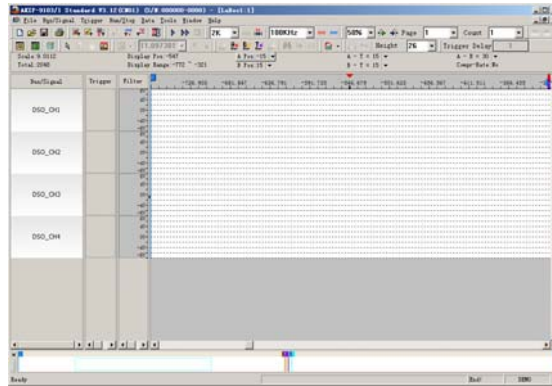

Channel Height Setting: Set it from 30 to 400.
DSO Settings: when the button is pressed, the below box will be displayed.

Master: Set the Master to be LA or Oscilloscope according to the hardware usage mode.

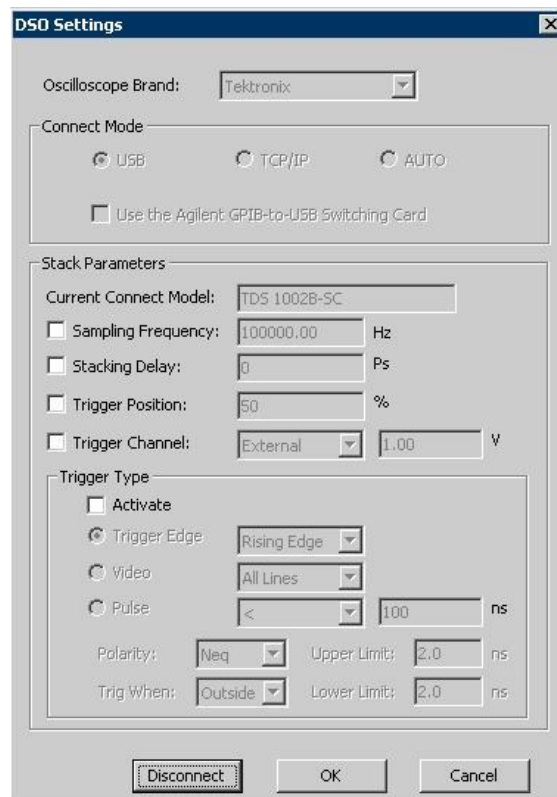

Oscilloscope Brand: User can select the oscilloscope brand to stack, such as Tektronix. Then click the Connect button to show the

	<p>oscilloscope model, None will be displayed if no oscilloscope is connected.</p> <p>Connect Mode: Users can select USB, TCP/IP or Auto. If selecting the USB, the oscilloscope will connect with the PC by USB. If selecting the TCP/IP, the oscilloscope will connect the PC by TCP/IP, and the IP needs to be set the same as the IP of current PC. If selecting the Auto, users can connect without any setting.</p> <p>Current Connect Model: Display the oscilloscope's name.</p> <p>Sampling Frequency: It matches with the sec/case spin button of oscilloscope. Its value is the reciprocal of horizontal scale, the range is 1/5ns ~ 1/50s.</p> <p>Stacking Delay: It is used to align the T Bar and the T Bar of LA when users use the main program to show the oscilloscope's waveform. The range is -1000000ps~+1000000ps.</p> <p>Trigger Position: It matches the horizontal spin button of oscilloscope, the range is 0~100%.</p> <p>Trigger Channel: It matches the trigger level spin button of oscilloscope, the lever range is -16V~ 16V.</p> <p>Trigger Type: The other options is available only after the active option is selected.</p> <p>A. Trigger Edge: Users can select Rising Edge or Falling Edge.</p> <p>B. Pulse: Users can select <, >, =, !=; the range is 33ns~10s.</p> <p>C. Video: Users can select Line, All Lines, Odd Field, Even Field and All Field.</p> <p>Connect: Click the Connect to link with the oscilloscope, and the Connect button will change into Disconnect button.</p> <p>Users can set the oscilloscope by selecting the options and inputting values, then pressing OK.</p> <p>Note: the Stacking Delay is set into the main program. If no oscilloscope is connected or the oscilloscope disconnects, the whole options under the Stack Parameters are unable.</p>
--	--

	For the above details, please refer to the 4.12.
--	--

Window

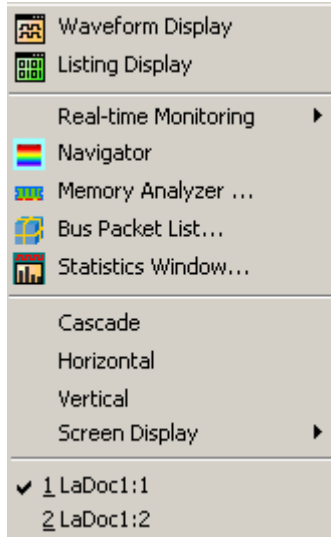

Fig 3-84: **Window** Menu



Fig 3-85: **Window** Tool Box

Menu Bar: **Windows**

Menu Item

Detail Menu & Dialog Box

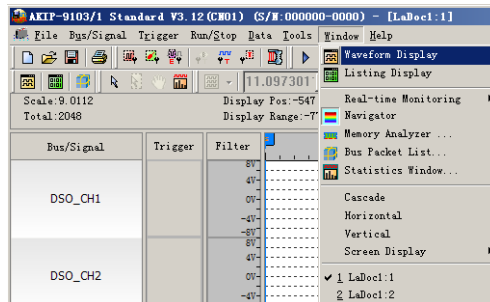

Fig 3-86: **Display** Signals in **Waveform**.

Listing Display

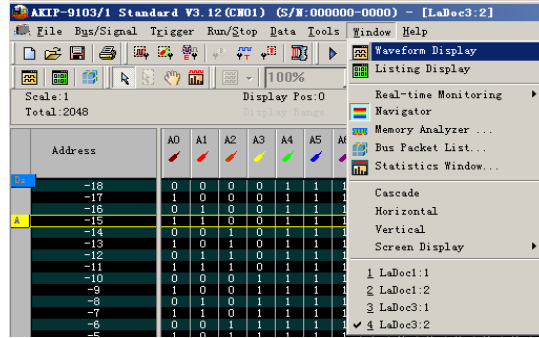
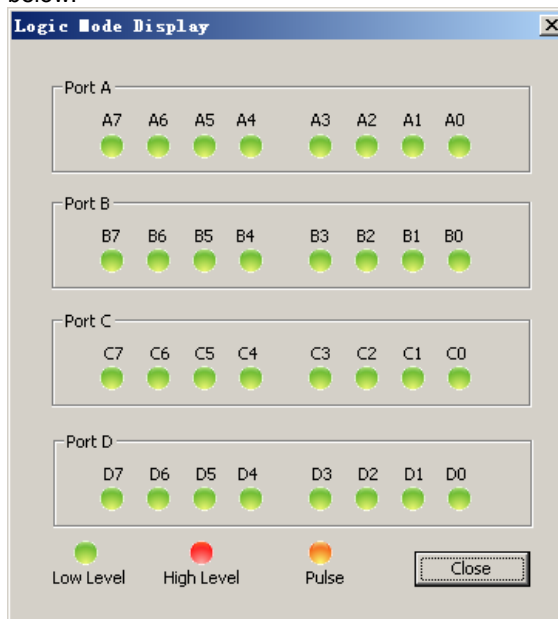

Fig 3-87: Display Signals in Listing.

Real-time Monitoring: The Level and the Frequency of all the channels can be monitored according to the Real-time Monitoring function of software, which is convenient for users to know the current data status of each channel. There are two display mode, see as below:

Real-time Monitoring



Logic Mode Display

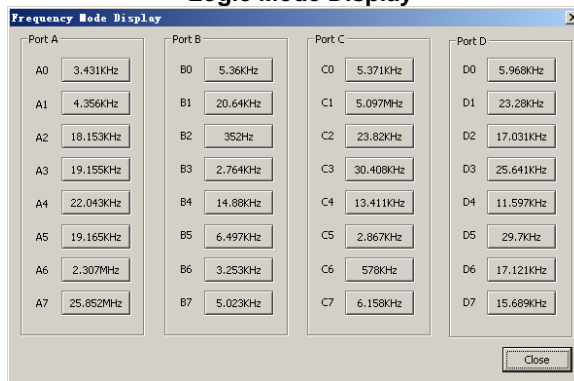

Frequency Mode Display

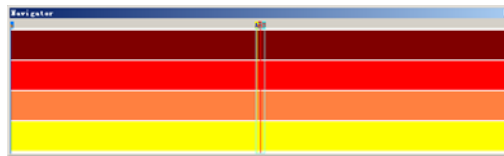
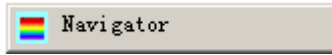

Fig 3-88: Navigator Window

Tip:

The Navigator Window is displayed under the waveform display area when activating the Logic Analyzer. The Navigator displays the waveform length of all the captured data; it only can display the waveform of the data of four channels. In the Navigator Window, users can click the Left Key of the mouse to select the waveform randomly. The selected waveform keeps pace with the waveform in the waveform display area. The size of the selection frame is in inverse proportion to the Zoom Rate; the larger the Zoom Rate is, the smaller the size of the selection frame is. Users can also click the Right Key of the mouse to select the displayed channel.

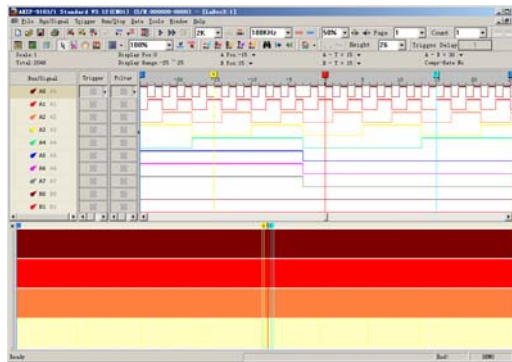

Fig 3-89: Navigator Window under the waveform display area

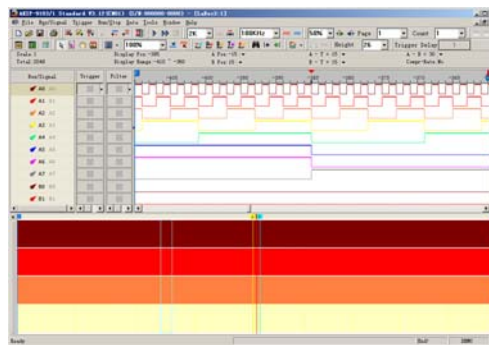

Fig3-90: Blue Frame in the Navigator Window

There is a blue frame in the above Navigator Window. Users can click the Left Key of the mouse to select the waveform randomly.

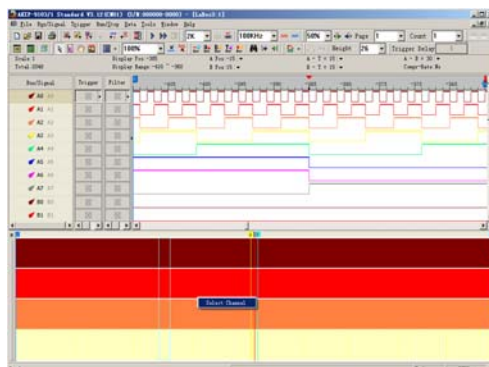

Fig3-91: Select Channel button

After clicking the Right Key of the mouse, the Select

Channel dialog box will pop up as below.

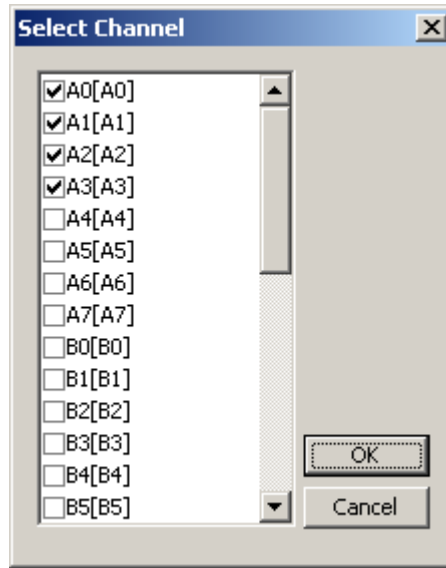

Fig3-92: Select Channel dialog box

In the Select Channel dialog box, users can select the channel which users want to display; users can select four channels at most; the defaulted channels are A0, A1, A2 and A3 (there are four channels in total).

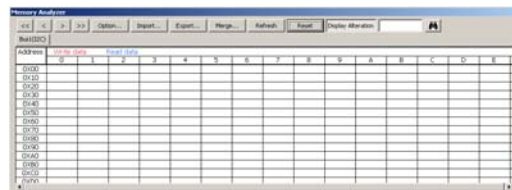
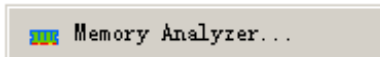
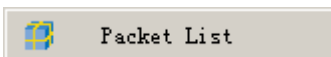

Fig 3-93: **Memory Analyzer** Interface

See Section 4.11 for detailed instructions.



Tip:

Setting: Set up the packet list.

Refresh: Click it, the content in the packet list will be refreshed.

Export: Users can use the fragment to work, record and analyze the packet list data. As Export, according to the packet list arrangement, it exports the text file and csv file.

Synch Parameter: Open the **Synch Parameter Setting** dialog box.

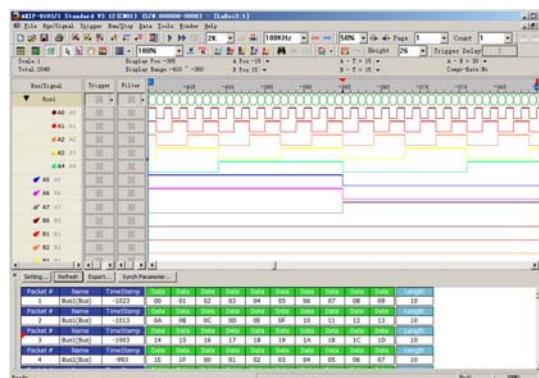

Fig3-94: Display Packet List

Statistics Window...

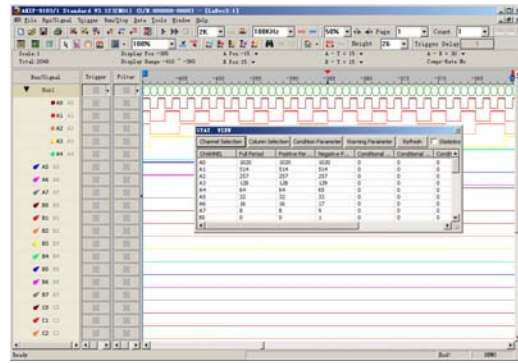

Fig3-95: Statistics Window

See Section 3.3 for detailed instructions.

Cascade

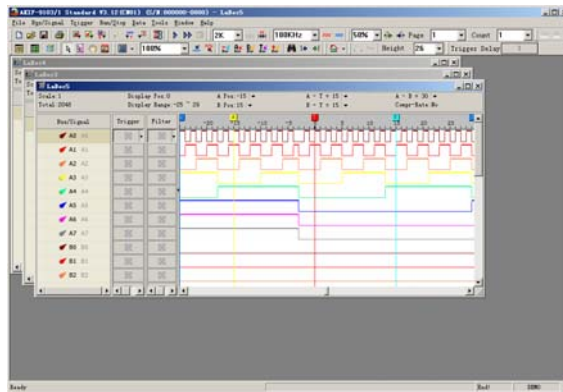

Fig 3-96: Cascade Workspace(s)

Horizontal

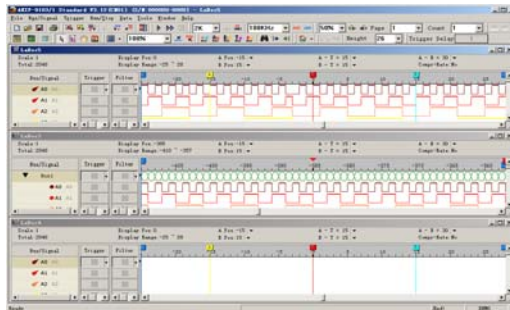

Fig 3-97: Align Workspace(s) Horizontally

Vertical

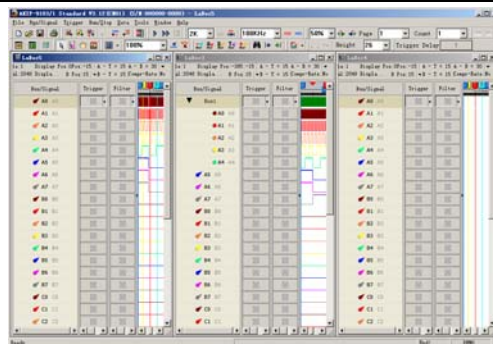
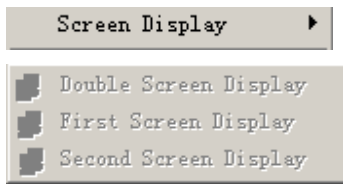



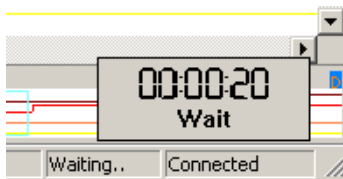

Fig 3-98: Align Workspace(s) Vertically



Screen Display:

When there are two displayers connecting, users can select , Double Screen Display, to display waveforms on both two displayers; it is convenient for displaying more waveforms. , First Screen Display, or , Second Screen Display, can also be selected to display waveforms on the first displayer or the second displayer.



Stopwatch Function

Stopwatch Function:

The function will show at right corner of the bottom of the screen while sampling data. It times from users pressing the ensured key at the Bus Property dialog box to Bus insert sending back analyzed data. Please look at the left figure.

It has five functions as following:

Time of waiting for triggering, Time of triggering success, Time of sampling data, Time transmitted to computer after sampling data finished and Time of Bus data overloading.

Help

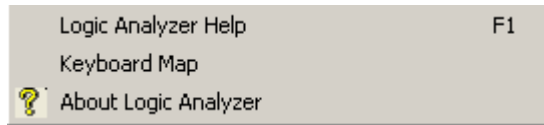
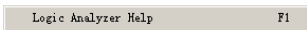
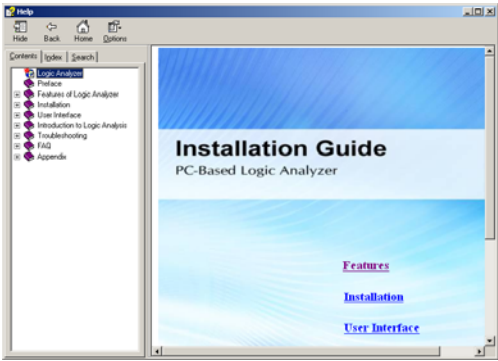
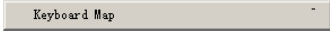
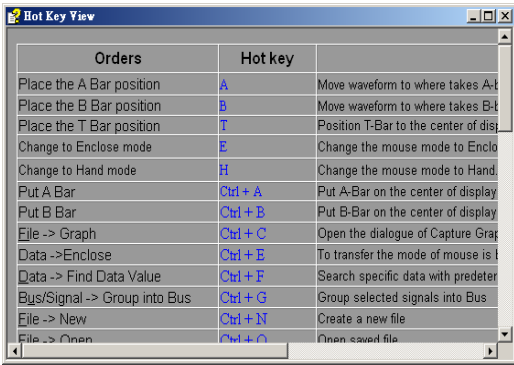
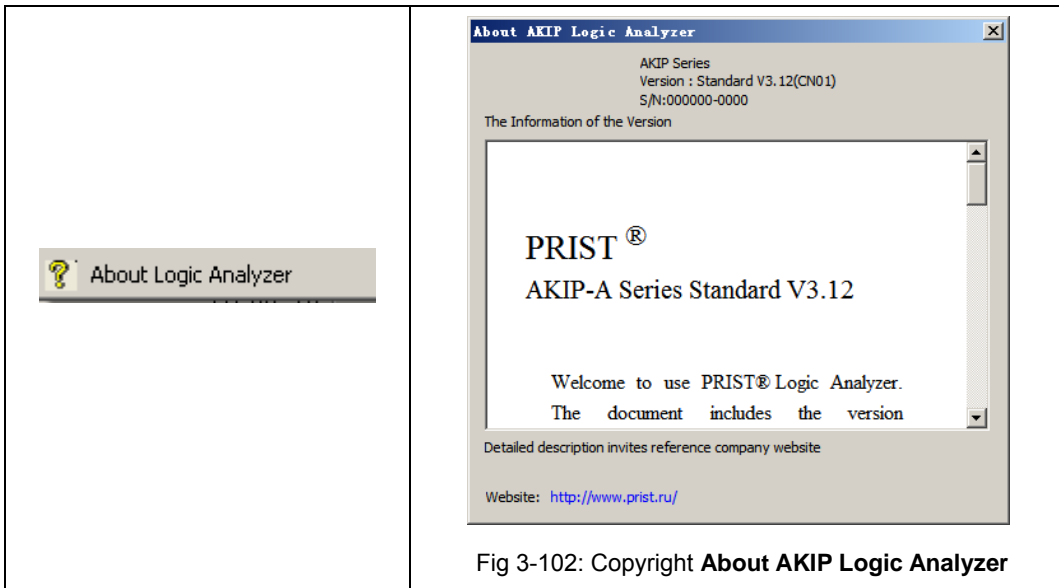

Fig 3-99: Help Menu

Menu Bar: Help

Menu Item	Detail Menu & Dialog Box
	 <p>Fig 3-100: Open Logic Analyzer Help file.</p>
	 <p>Fig 3-101: The Table of Keyboard Map</p>



Tip:
The function of Software Version Information Display for AKIP LA means that the software will open a small window which displays the software version, new functions and bug modifications when activating the software. It is convenient for users to know the information of the present software version.

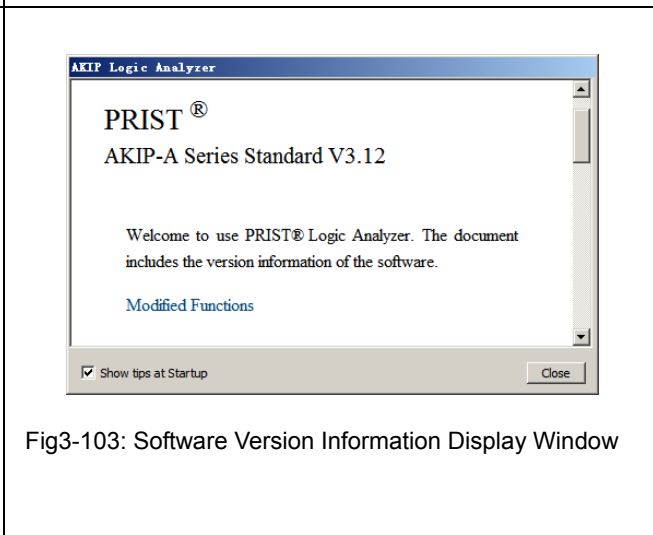

Right Key

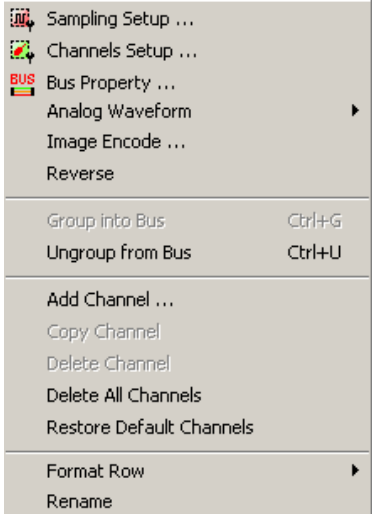
Menu Item	Detail Menu & Dialog Box
Right Key Menu on the Bus/Signal Column	

Tip:

The Right Key menu is added on the basis of the Bus/Signal menu. So the function of Sampling Setup, Channels Setup, Bus Property, Group into Bus, Ungroup from Bus, Format Row and Rename are the same as those in the Bus/Signal menu. And the function of the Analog Waveform is the same as that in the Tools menu.

Fig 3-104: Right Key Menu on the Bus/Signal Column

Image Encode ...

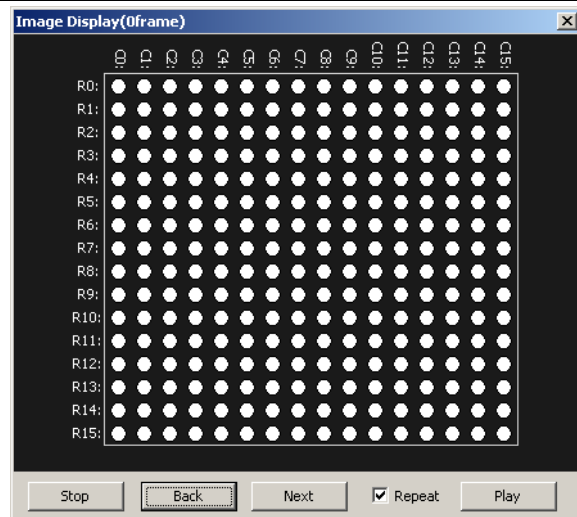

Decode the data of Protocol Analyzer and show it in image(the Protocol Analyzer shall support this function).

Reverse

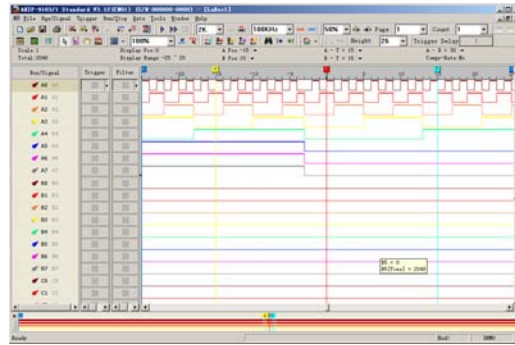

Tip:

This function of Reverse is used to reverse the collected signal. Change the High Level into the Low Level; change the Low Level into the High Level. The Reverse of Waveform Mode displays with the dashed, so it is easy to distinguish.

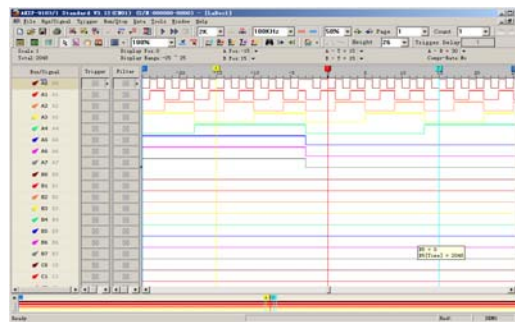

Fig3-105: Reverse Function Displayed in the Waveform Window

Add Channel ...

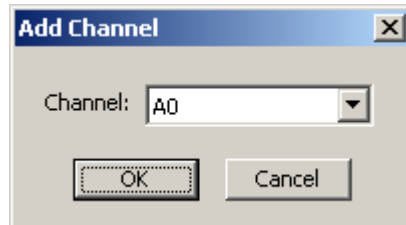

Fig 3-106: Add the required channel in the Bus/Signal column.

Copy Channel

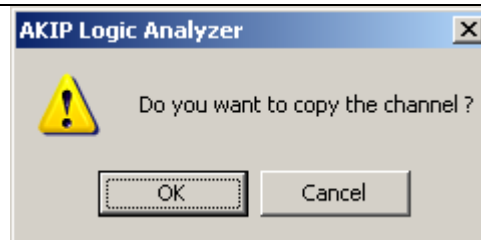

Fig 3-107: Copy the selected channel in Bus/Signal column.

Delete Channel

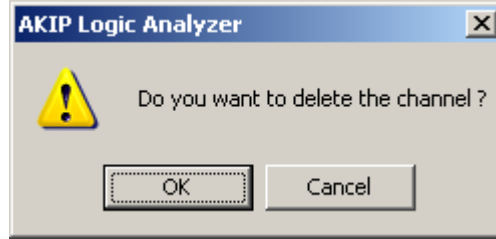

Fig3-108: Delete the selected channel in Bus/Signal column.

Delete All Channels

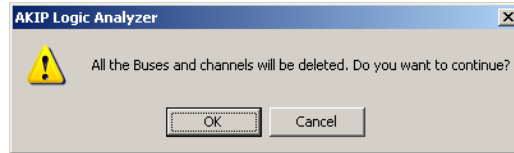

Fig 3-109: Delete all Buses and channels in Bus/Signal column.

Restore Default Channels

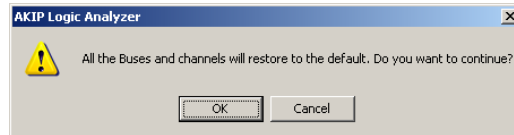

Fig3-110: Restore the deleted Buses and channels in Bus/Signal Column.

Right Key Menu on the Waveform Area

Tip:

The functions of the right key menu on the waveform area are similar to those of the Data menu.

The menu adds the functions, such as Place Ds and Dp, Add Bar in the waveform display area.

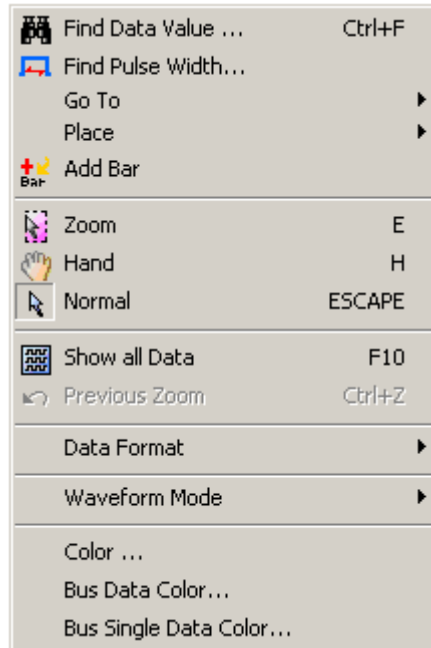

Fig3-111: Right Key Menu on the Waveform Area



Tip:

The right key menu on the waveform area adds the function of Place Ds and

Place Dp. However the functions are only used after the Ds and Dp bars are activated, otherwise they will be disabled. These functions are the same as that of A Bar.

When the mouse is stopped at a special position, click the right key on the mouse, select the Place Ds or Place Dp, the Ds or Dp bar will move to the special position.

For example, Open “Select an Analytic Range”, select the special position is “-10”, and then select “Place Ds”. See the figure in the right column.

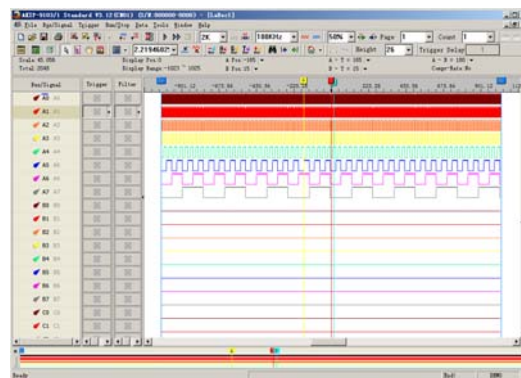
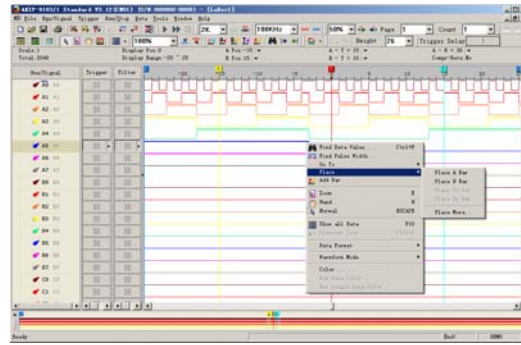
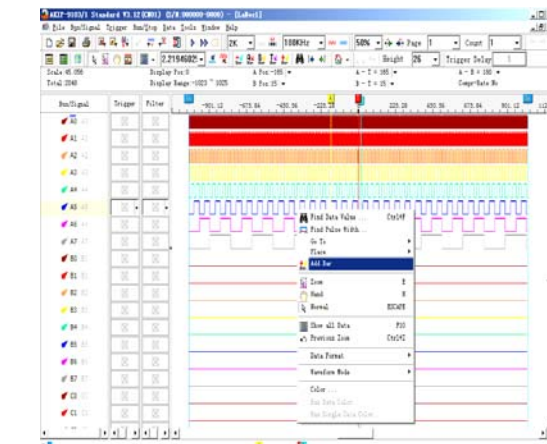

Fig3-112: Place Ds Bar



Tip:

When the mouse is located at a special position on the waveform area, click the right key to select the Add Bar function; a bar will be added automatically in the special position according to the sequence of the word and color. See the C Bar in the position “5” in the right column.



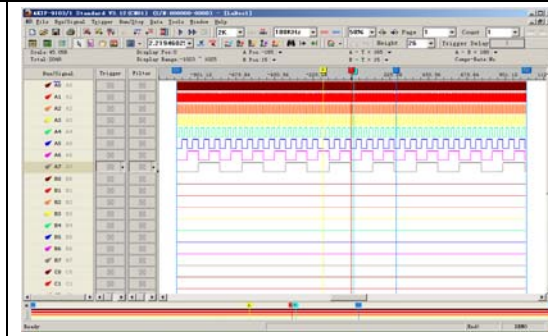



Fig3-113: Add a Bar on the Waveform Area.

3.2 Find Data Value

Find Data Value is a very useful tool to help the user to find data on the received signals.

Step1. Click the Find Data Value  icon; the dialog box of Waveform-Find will appear.

Step2. Using the pull-down menu, select the Bus/Signal Name.

The Bus/Signal listed on the pull-down menu represent the status of the Bus/Signal column as shown in Fig 3-114.

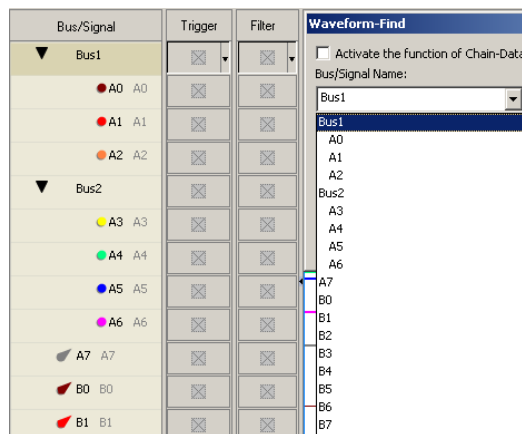

Fig 3-114

Step3. Choose the character for Find. The list of characters depends on whether it is a Bus, Signal, or the protocol analyzer such as I2C, UART, SPI, etc., which is being searched (See Figs 3-115, 3-116, 3-117, 3-118, 3-119, 3-120, 3-121, 3-122 and 3-123).

Bus: Choose among = , != , In Range and Not In Range (Enter the Min Value or Max Value).

Protocol Analyzer: Choose the segments bits of the protocol analyzer (Select the protocol analyzer item and enter the value for Min Value or Max Value).

Signal: Choose among Rising Edge, Falling Edge, Either Edge, High or Low.

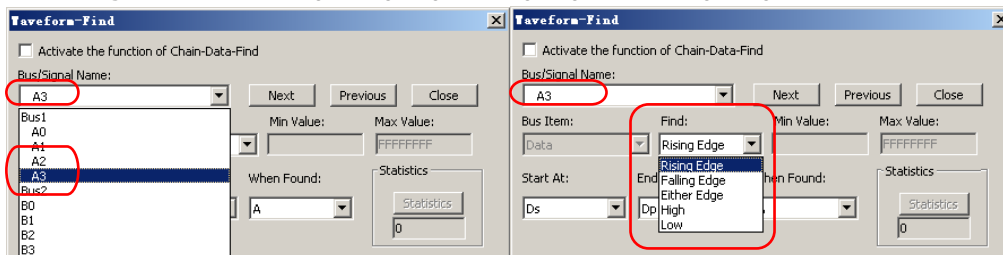

Fig 3-115: Waveform-Find Dialog Box of the Logic Signal

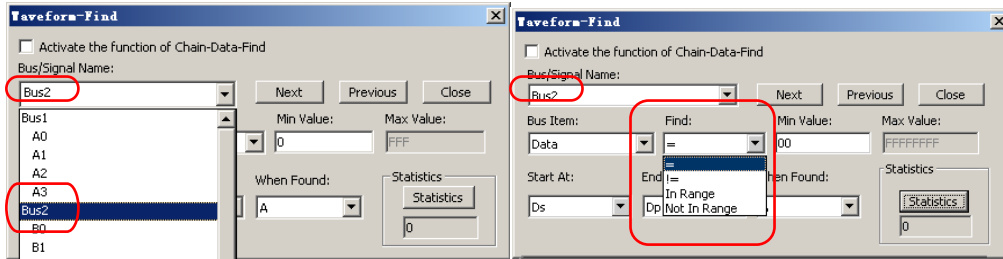

Fig 3-116: Waveform-Find Dialog Box of the Logic Bus

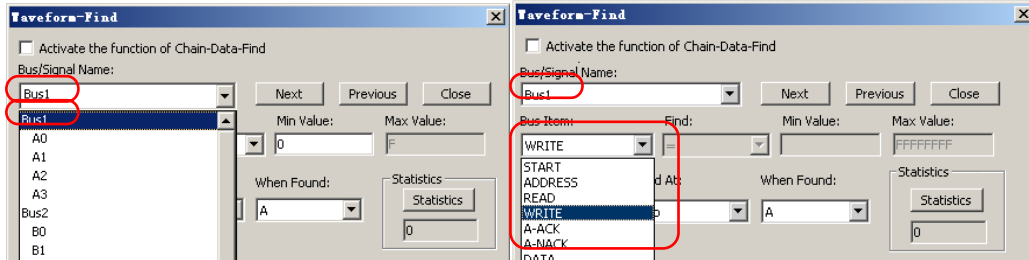

Fig 3-117: Waveform-Find Dialog Box of the Protocol Analyzer I2C

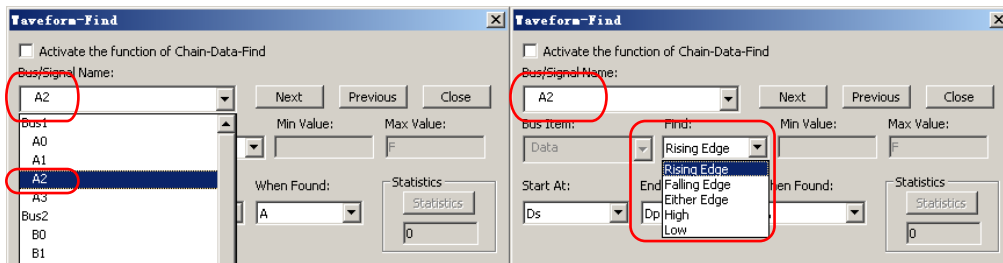

Fig 3-118: Waveform-Find Dialog Box of the I2C Signal

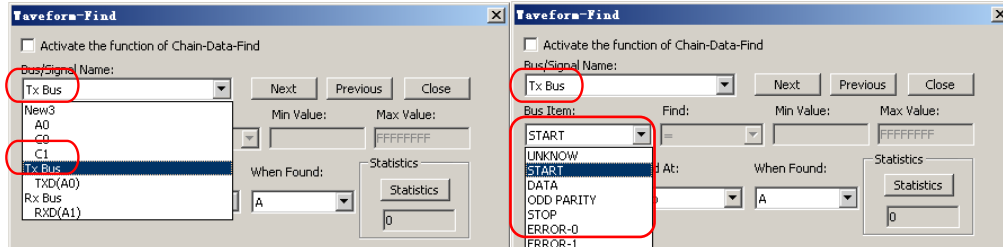

Fig 3-119: Waveform-Find Dialog Box of the Protocol Analyzer UART

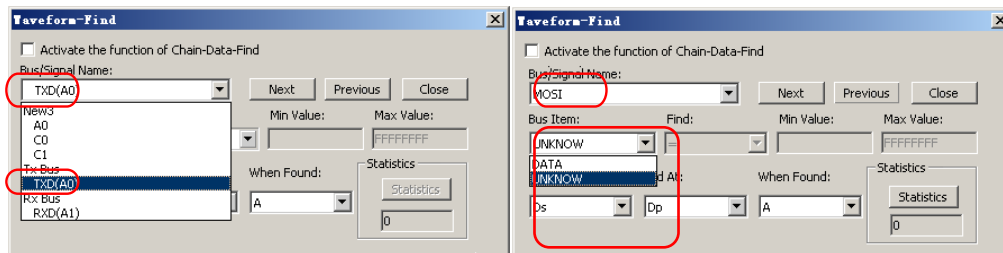

Fig 3-120: Waveform-Find Dialog Box of the UART Signal

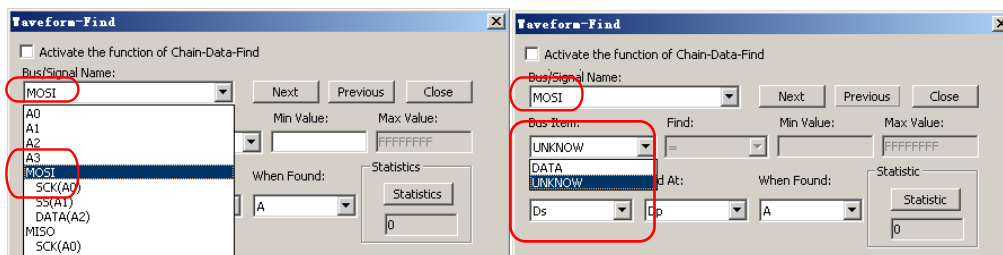

Fig 3-121: Waveform-Find Dialog Box of the Protocol Analyzer SPI

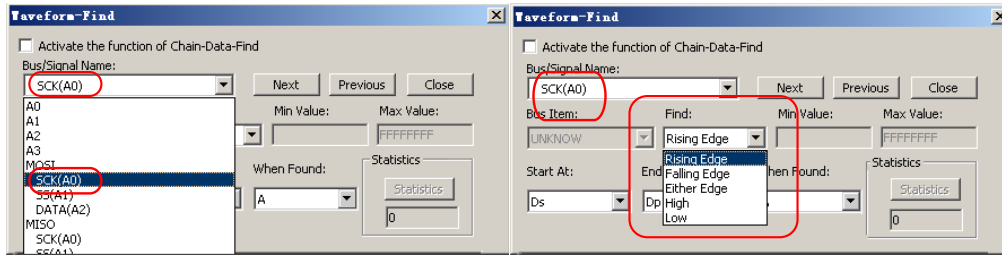

Fig 3-122: Waveform-Find Dialog Box of the SPI Signal

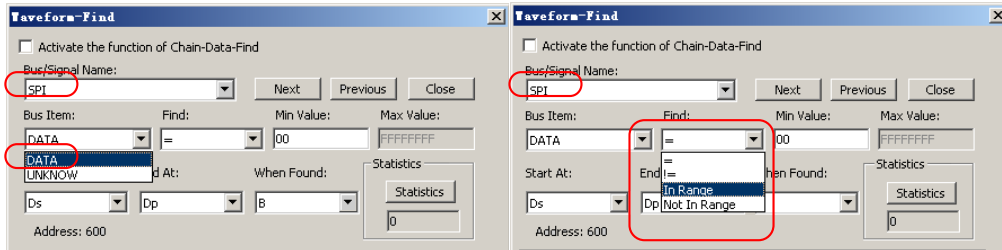

Fig 3-123: Waveform-Find Dialog Box of the Bus Item of the SPI Signal

- Step4.** Choose the position to start the search by selecting one of the following:
Start At: Ds T , A, B, C, etc.; **End At:** Dp, A, B, C, etc.. Then click **Next** or **Previous** to search it.
When Found: Choose a Bar to mark the result: A, B, C, etc..
- Step5.** Click **Statistics** to show the number of instances of the search results.
- Note:** It is available only when searching through a Bus.

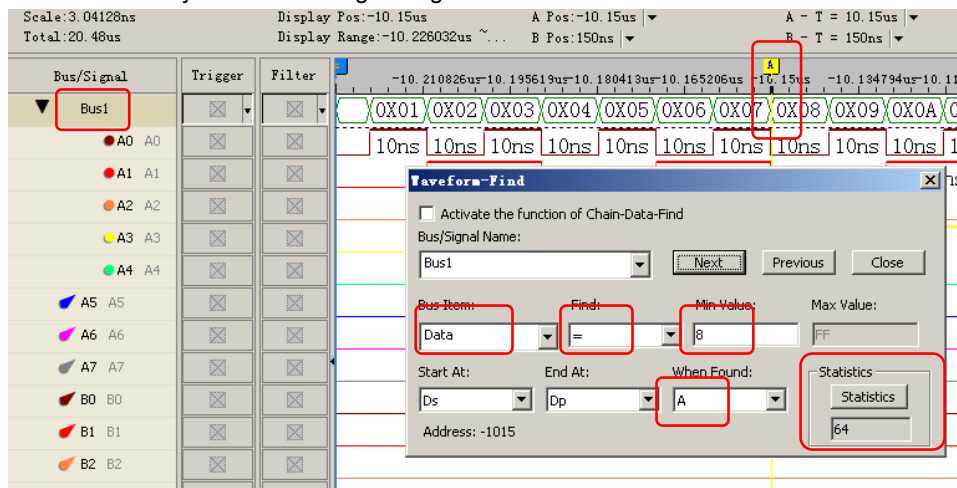

Fig 3-124: The A Bar is placed at the 0X08 of Bus1 where the condition of the Waveform-Find is set. The Statistic of Waveform-Find shows a "64".

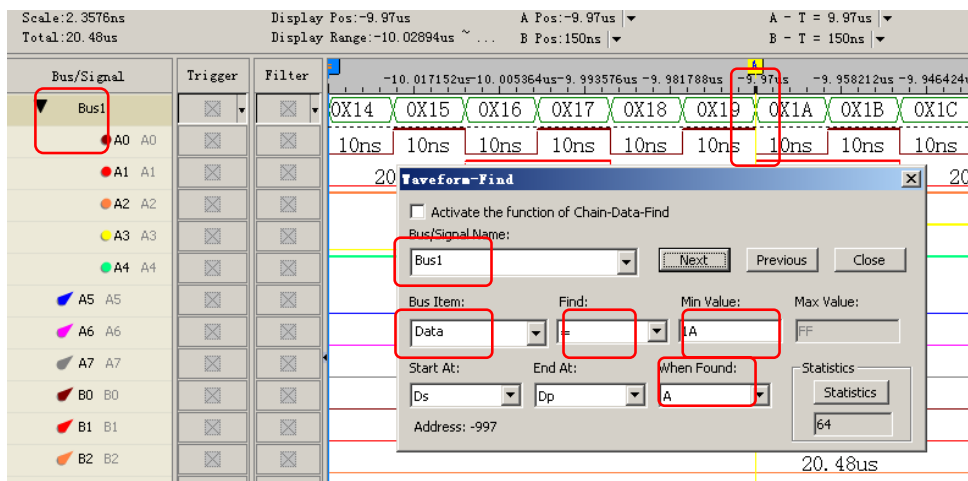

Fig 3-125: The A Bar is placed at the 0X1A of Bus1 where the condition of the Waveform-Find is set.

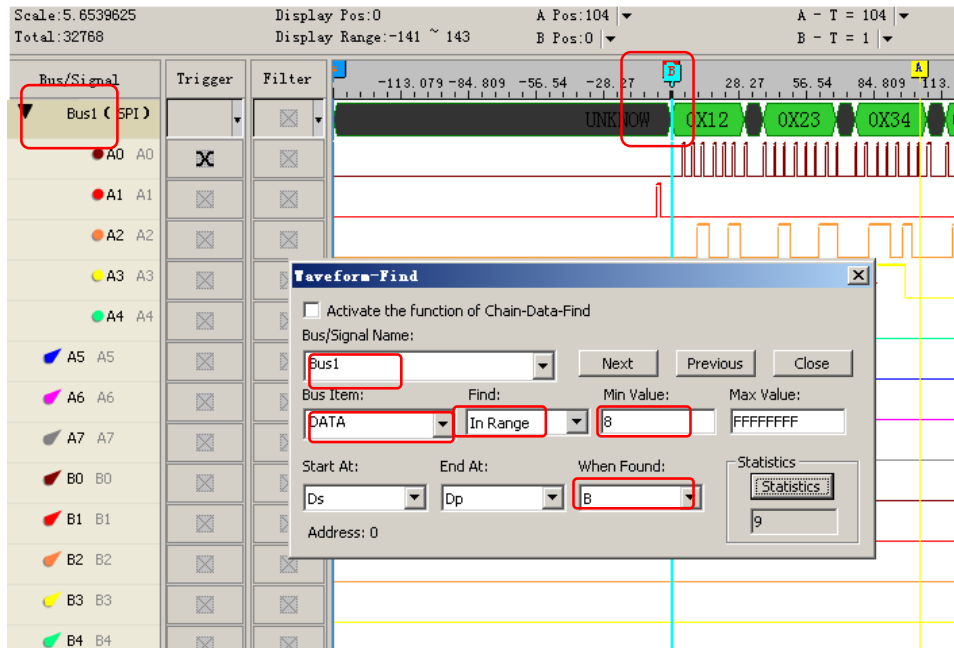

Fig 3-126: The B Bar is placed at the 0X12 of Data of Protocol Analyzer SPI where the condition of the Waveform-Find is set.

3.3 Statistics Feature

Section 3.3 presents detailed information on the **Statistics** feature in the software interface. The **Statistics** feature presents user information pertaining to nine periodicities: **Full Period**, **Positive Period**, **Negative Period**, **Conditional Full Period**, **Conditional Positive Period**, **Conditional Negative Period**, **Start Pos**, **End Pos** and **Selected Data**.

Click on the **Statistics** icon , and an interface like Fig 3-127 or Fig 3-128 will appear.

CHANNEL	Full Period	Positive Per...	Negative P...	Conditional ...	Conditional ...	Conditional ...	Start Pos	End Pos
A0	515	515	515	0	0	0	Ds	Dp
A1	260	260	260	0	0	0	Ds	Dp
A2	130	130	130	0	0	0	Ds	Dp
A3	65	65	65	0	0	0	Ds	Dp
A4	33	33	33	0	0	0	Ds	Dp
A5	17	17	17	0	0	0	Ds	Dp
A6	9	9	9	0	0	0	Ds	Dp
A7	5	5	5	0	0	0	Ds	Dp
B0	0	0	1	0	0	0	Ds	Dp
B1	0	0	1	0	0	0	Ds	Dp
B2	0	0	1	0	0	0	Ds	Dp
B3	0	0	1	0	0	0	Ds	Dp
B4	0	0	1	0	0	0	Ds	Dp
B5	0	0	1	0	0	0	Ds	Dp
B6	0	0	1	0	0	0	Ds	Dp
B7	0	0	1	0	0	0	Ds	Dp
C0	0	0	1	0	0	0	Ds	Dp
C1	0	0	1	0	0	0	Ds	Dp

Fig 3-127: **STAT. VIEW**

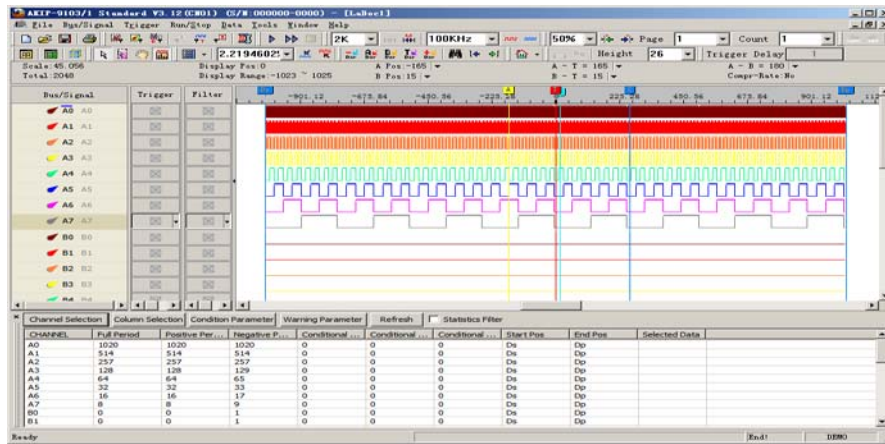

Fig 3-128: Logic Analyzer with Statistics Enabled

There are four options for adjusting how statistical information may be presented. These four options are **Channel Selection**, **Column Selection**, **Condition Parameter** and **Warning Parameter**.

Channel Selection

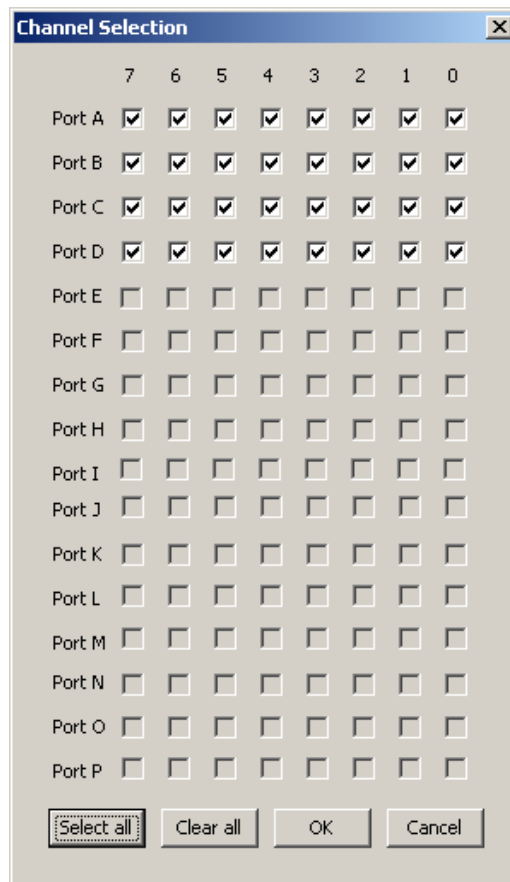

Fig 3-129: **Channel Selection**. Allow the choice of pins in which port will be included in the statistical analysis of a test run.

Column Selection

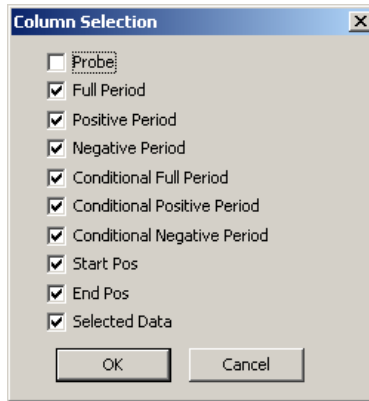

Fig 3-130: **Column Selection**. Allow the choice of items which will be considered in the statistical results.

Condition Parameter

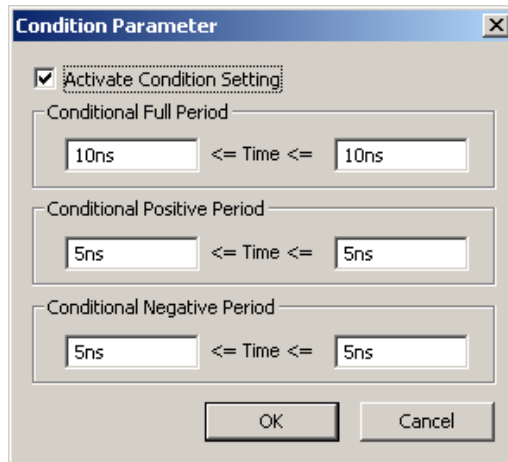

Fig 3-131: **Condition Parameter**. Allow the setting of time intervals for Conditional Full Period, Conditional Positive Period and Conditional Negative Period.

STAT. VIEW								
Channel Selection	Column Selection	Condition Parameter	Warning Parameter	Refresh	<input type="checkbox"/> Statistics Filter			
CHANNEL	Full Period	Positive Per...	Negative P...	Conditional ...	Conditional ...	Conditional ...	Start Pos	End Pos
A0	515	515	515	0	0	0	Ds	Dp
A1	260	260	260	0	0	0	Ds	Dp
A2	130	130	130	0	0	0	Ds	Dp
A3	65	65	65	0	0	0	Ds	Dp
A4	33	33	33	0	0	0	Ds	Dp
A5	17	17	17	0	0	0	Ds	Dp
A6	9	9	9	0	0	0	Ds	Dp
A7	5	5	5	0	0	0	Ds	Dp
B0	0	0	1	0	0	0	Ds	Dp
B1	0	0	1	0	0	0	Ds	Dp
B2	0	0	1	0	0	0	Ds	Dp
B3	0	0	1	0	0	0	Ds	Dp
B4	0	0	1	0	0	0	Ds	Dp
B5	0	0	1	0	0	0	Ds	Dp
B6	0	0	1	0	0	0	Ds	Dp
B7	0	0	1	0	0	0	Ds	Dp
C0	0	0	1	0	0	0	Ds	Dp
C1	0	0	1	0	0	0	Ds	Dp

Fig 3-132: The Numbers of Data Qualified by Condition Parameter

Warning Parameter

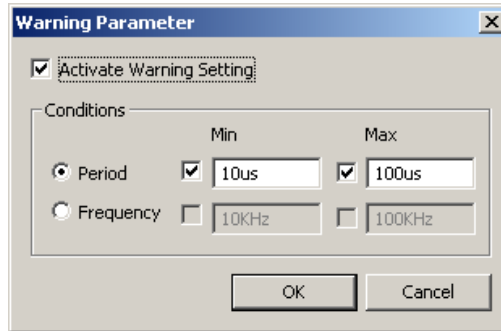

Fig 3-133: **Warning Parameter**. Set the conditions which will be marked to call users' attention.

STAT. VIEW									
Channel Selection	Column Selection	Condition Parameter	Warning Parameter	Refresh	Statistics Filter				
CHANNEL	Full Period	Positive Per...	Negative P...	Conditional ...	Conditional ...	Conditional ...	Start Pos	End Pos	
A0	515	515	515	0	0	0	Ds	Dp	
A1	260	260	260	0	0	0	Ds	Dp	
A2	130	130	130	0	0	0	Ds	Dp	
A3	65	65	65	0	0	0	Ds	Dp	
A4	33	33	33	0	0	0	Ds	Dp	
A5	17	17	17	0	0	0	Ds	Dp	
A6	9	9	9	0	0	0	Ds	Dp	
A7	5	5	5	0	0	0	Ds	Dp	
B0	0	0	1	0	0	0	Ds	Dp	
B1	0	0	1	0	0	0	Ds	Dp	
B2	0	0	1	0	0	0	Ds	Dp	
B3	0	0	1	0	0	0	Ds	Dp	
B4	0	0	1	0	0	0	Ds	Dp	
B5	0	0	1	0	0	0	Ds	Dp	

Fig 3-134: The numbers of data qualified by warning conditions are printed in black, otherwise in red.

3.4 Customize Interface

Section 3.4 presents detailed instructions pertaining to how to **modify the Waveform Display Mode**, how to **modify the Ruler Mode**, how to **modify the Waveform Height**, and how to **modify the Correlated Setting**.

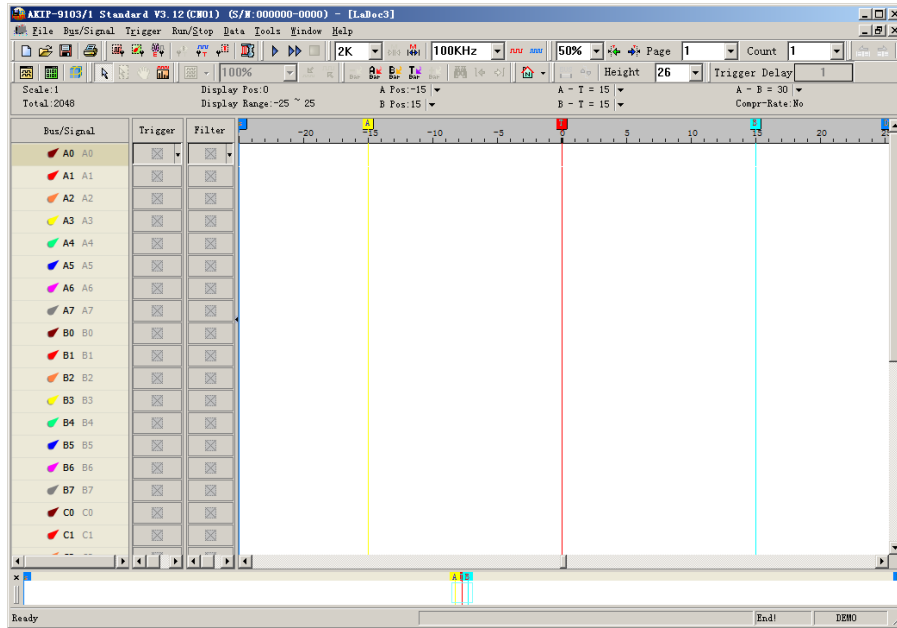

Fig 3-135: The Interface Layout Shown in Default Settings

3.4.1 Modify Waveform Display Mode

To modify the display mode, users can use icons on the tool bar/box, or menu.
For the menu, go to **Tools** and click **Customize**. See Fig.3-136.

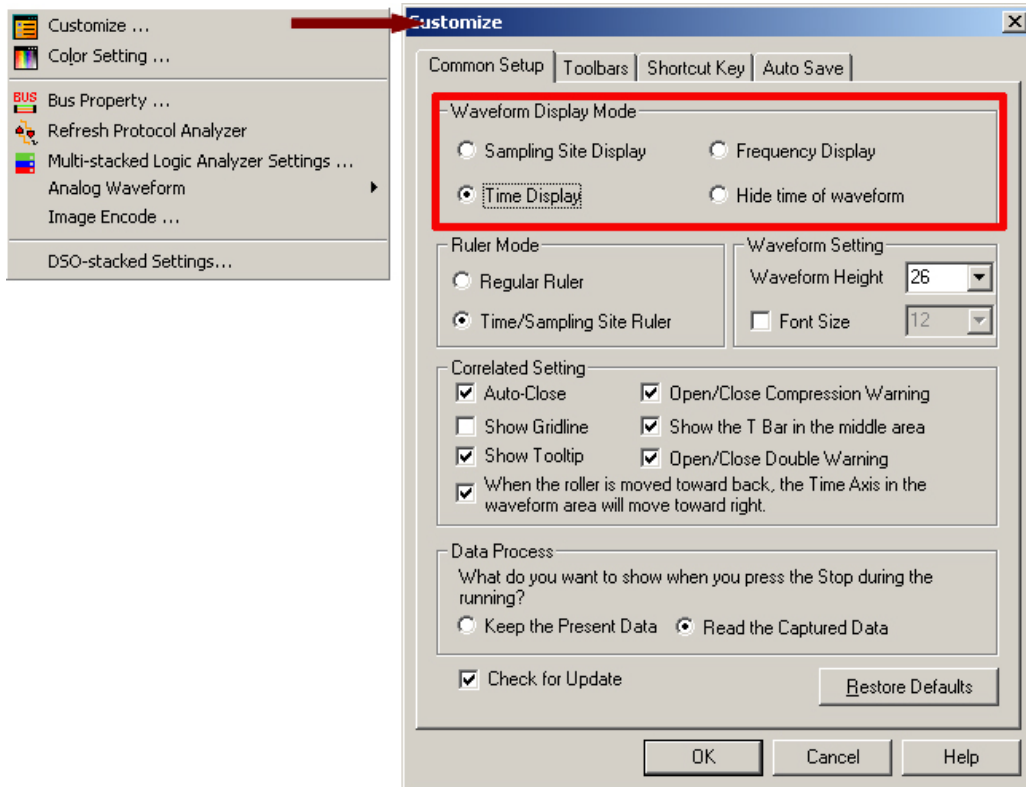

Fig 3-136: Customize the Display Mode by Using the Tool Bar

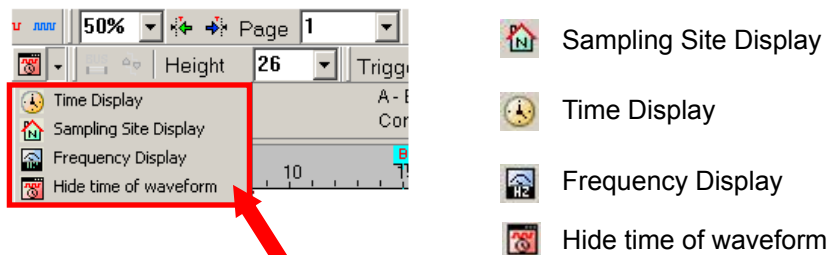

Fig 3-137: Tool Bar

Waveform Display Mode – There are four display modes to determine the method of capturing data from sampling: Sampling Site Display, Time Display, Frequency Display and Hide time of waveform.

3.4.2 Modify Ruler Mode

Use the menu to modify the Ruler Mode.

Go to **Tools** and click **Customize**. See *Fig. 3-138*.

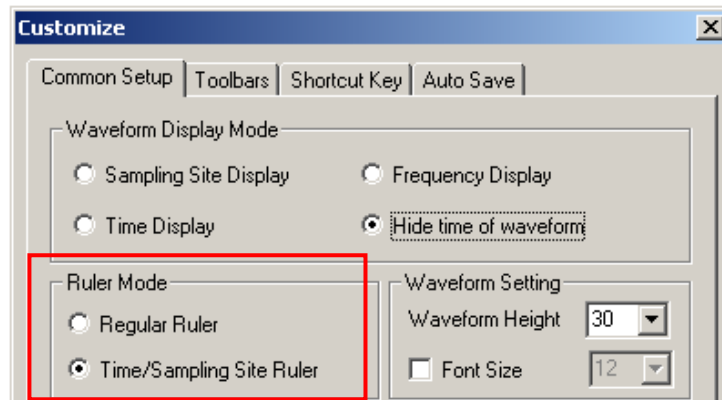

Fig 3-138: Ruler Mode

Regular Ruler

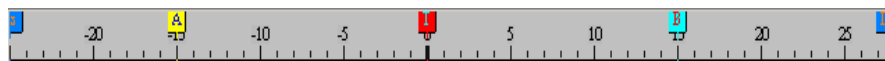

Fig 3-139: Scales in Regular Ruler

Time/Sampling Site Ruler



Fig 3-140: Scales in Time/Sampling Site Ruler

Ruler Mode – There are two styles of Ruler: (Regular Ruler, Time/Sampling Site Ruler)

Regular Ruler:

Presented in increments of 5.

Time/Sampling Site Ruler (default):

Presented in increments of 50us.

3.4.3 Modify Waveform Height & Correlated Setting

To modify Waveform Height, click **Tools** → **Customize**.

Waveform Height

Set the height of waveform (18-100) in chosen items at toolbar that will show the amplitude of the waveform.

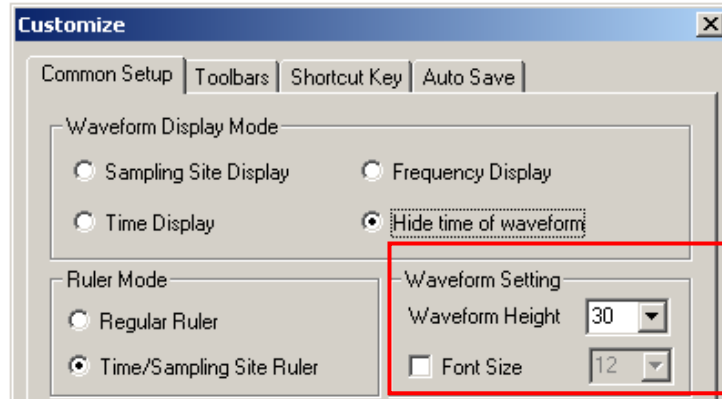

Fig 3-141: Waveform Height

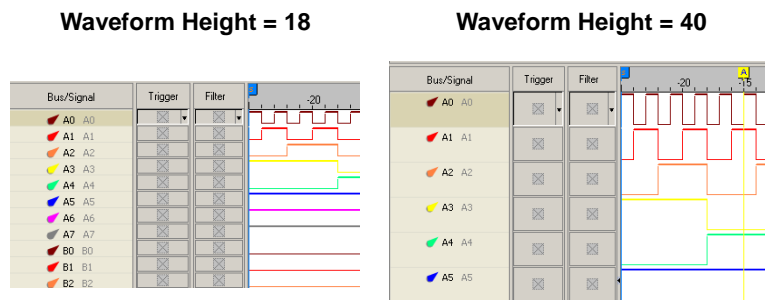

Fig 3-142-1

Fig 3-142-2

Fig 3-142: Examples of Waveform Height

Correlated Setting:

Select **Auto-Close** in the following figure.

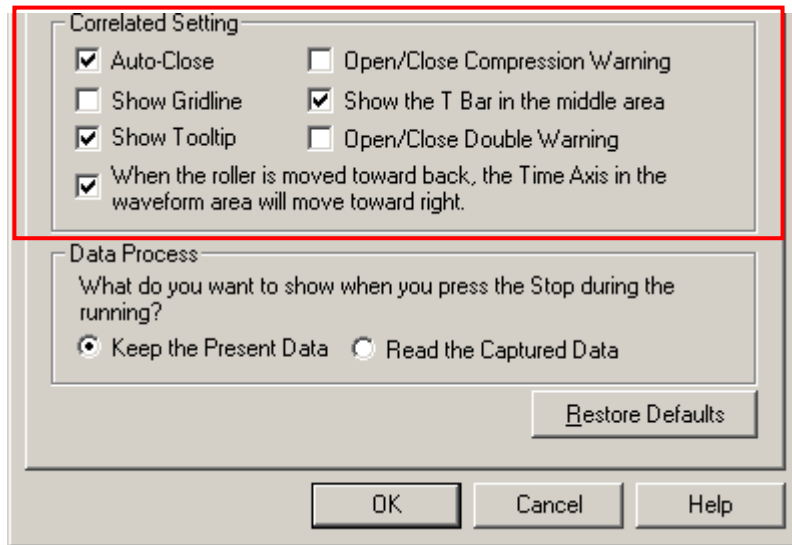

Fig 3-143: Correlated Setting

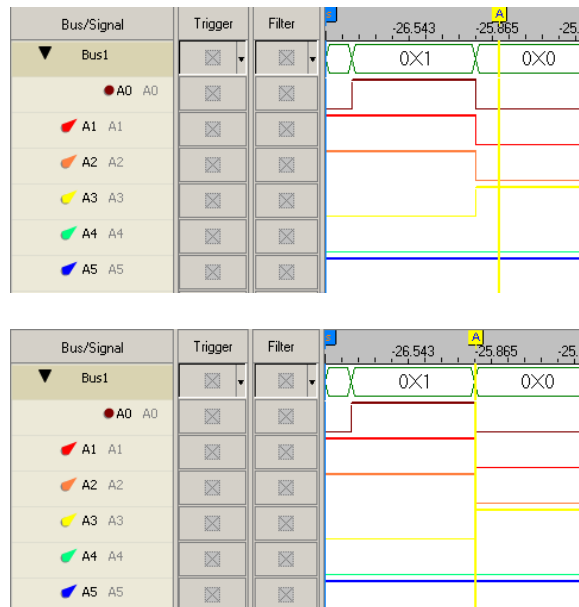

Fig 3-144: An Example for Auto-Close

Auto-Close - With the cursor in the channel, when users try to drag a Bar, the Bar will stop at the approaching edge of the channel (Rising Edge or Falling Edge).

Tip: In the above example, when dragging the A Bar, the A Bar will stop at the Falling Edge of A1.

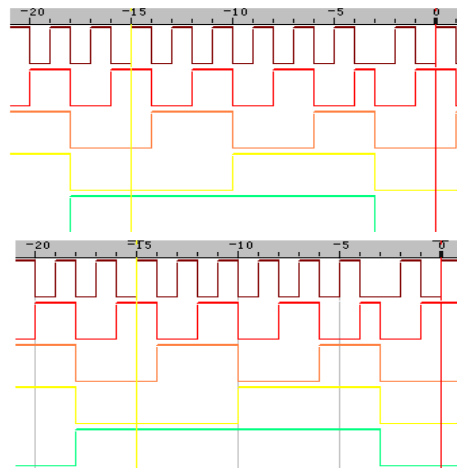

Fig 3-145: Gridlines

Show Gridline - The gridlines will be displayed on the waveform area.

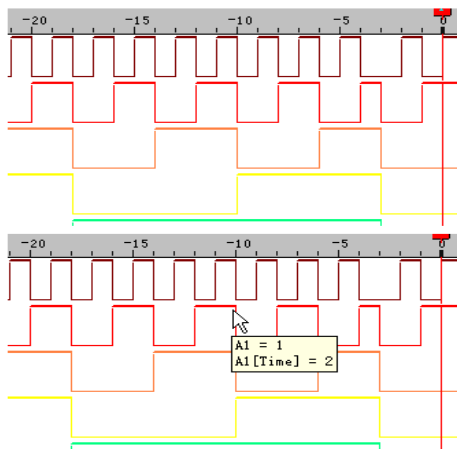

Fig 3-146 - Tooltips

Show Tooltip – Leave the mouse over a waveform and the description will be shown.

Show the T Bar in the middle area -Show the T Bar in the middle of the Waveform Display Area after triggering.

When the roller is moved toward back, the Time Axis in the waveform area will move toward - When the option is selected, if the Roller of the Mouse is moved backward, the Horizontal Scrollbar on the Software Display Area will be moved rightward.

Restore Defaults: The Waveform Display Mode, Ruler Mode, Waveform Setting, Correlated Setting and Data Process will return to the default setting.

3.5 Auto Save

To save the captured data for a long time, users can use icons on the tool bar/box, or menu.

For the dialog box, go to **File** menu to click **Auto Save** or go to **Tools** menu to select **Customize** and select **Auto Save**. See Fig 3-147.

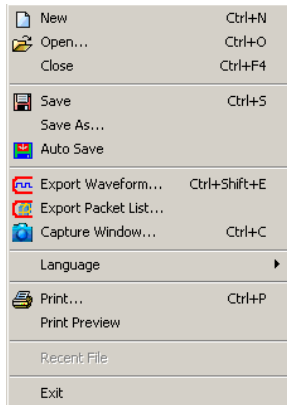

Fig 3-147-1: Auto Save on File Menu

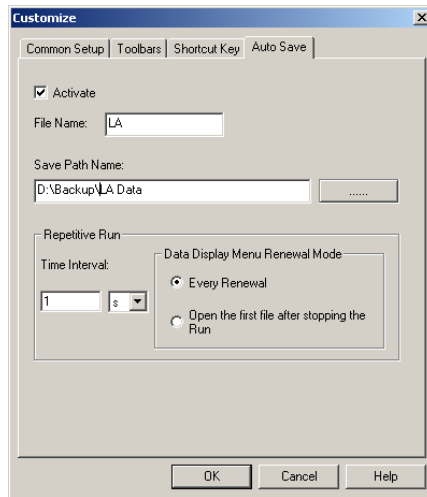



Fig 3-147-2: Auto Save Item of Customize

Fig 3-147: Auto Save

Auto Save: The default is not activated; after activating, it keeps working and users also can choose **Cancel** to close it.

Activate: The default is not activated: after activating, it keeps active and users also can choose **Cancel** to close it.

File Name: Before users name the file, the file name is defaulted as LA. In fact, the saved file name can add a serial number for the file automatically.

Save Path Name: Users can enter the path directly or choose the path from the selected path button .

Time Interval: When the auto save function is activated, the time interval from one finished sampling to the next activated sampling can be set according to users' requirements; the default is 1s, and the unit can be selected from s(second), m(minute) and hr(hour).

Every Renewal: When the repetitive run is activated, the waveform image or the state image will renew again and again.

Open the first file after stopping the Run: When the repetitive run function is activated, the waveform only displays the first file and it isn't renewed; when the repetitive run is stopped, the waveform still displays the first file.

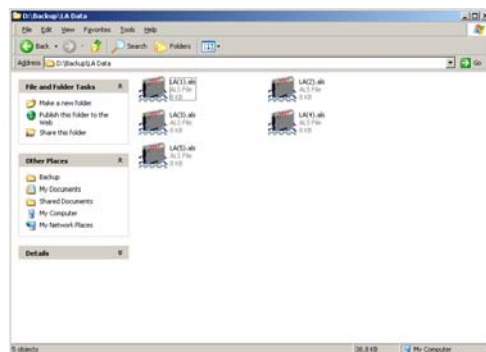

Fig3-148: Auto Save

3.6 Color Setting

To modify Color, click **Tools** → **Color Setting**.

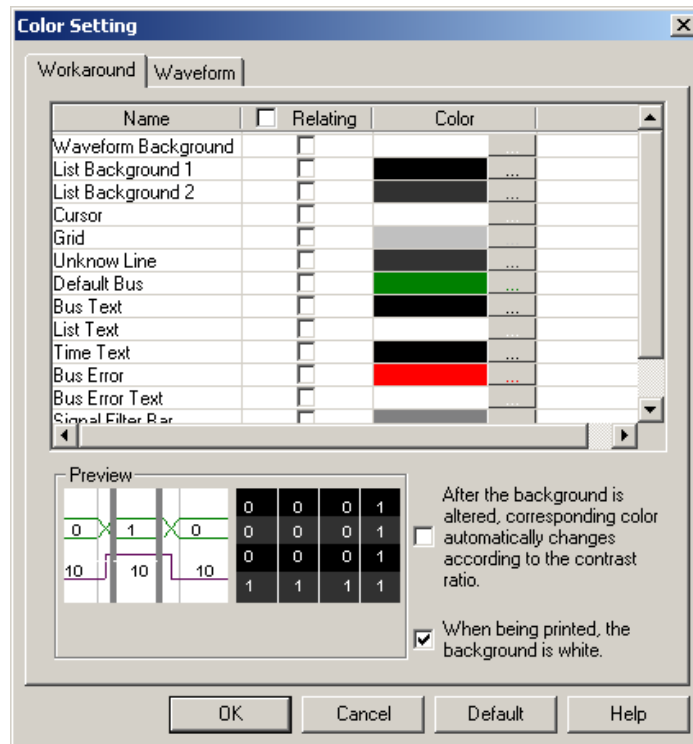

Fig 3-149: Workaround and Waveform Color Setting

Workaround – Set the workaround color of the Logic Analyzer and the text.

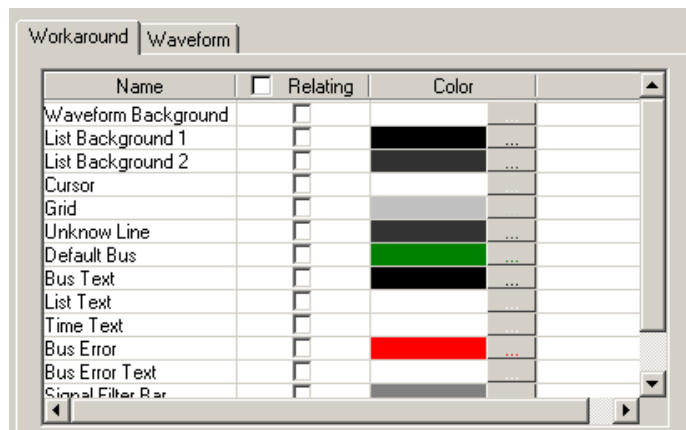

Fig 3-150: Workaround Color Interface

Waveform Background: The Logic Analyzer's Waveform Viewer Background Color.

List Background 1: The Logic Analyzer's First Listing Viewer Background Color.

List Background 2: The Logic Analyzer's Second Listing Viewer Background Color.

All optional items include the current color of Cursors, Grid, Unknown Line, Default Bus, Bus Text, List Text and Time Text (users can scroll the vertical wheel to view the selectable items).

Bus Error: Users can configure the color of Bus Error Data from the Color Setting dialog box.

Bus Error Text: Users can configure the color of Bus Error Text from the Color Setting dialog box.

Relating: When users select one item to change the color of the item, and users want to change other items into the same color, they can select other items at the same time in the Relating column, then the selected items will be changed into the same color. So it is convenient for users to change many items into the same color once.

After the background is altered, corresponding color automatically changes according to the contrast ratio: When users set the color for the workaround and select the option, the system will switch other colors automatically to become the contrast color.

When being printed, the background is white: When being printed, the background color is white.

Waveform – Change the color of the Buses or signals on the waveform area.

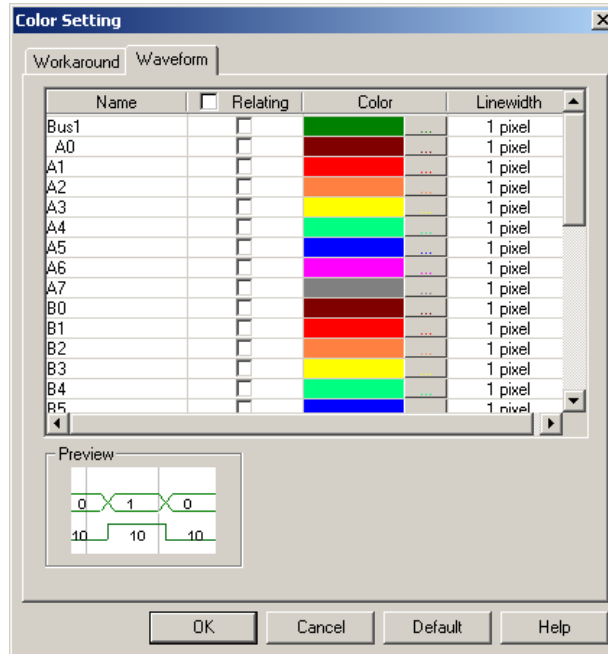

Fig 3-151: Waveform Color Interface

Waveform: The channel color can be varied by users.

Linewidth: The linewidth can be adjusted by the users' requirements; there are three options, 1 pixel, 2 pixel and 3 pixel.

3.6.1 Modify Workaround Color

To modify the workaround color, click the color block shown in Fig 3-151. A **Color** panel, shown in Fig 3-152 will appear. Select a color shown on the panel or click on **Define Custom Colors** to create the desired color.

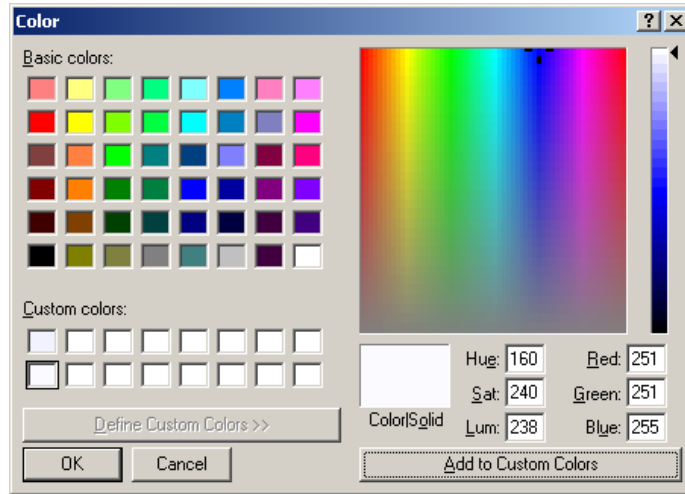

Fig 3-152: **Color** Panel with Its Advanced View

3.6.2 Modify Waveform Color

Foreground color refers to the color of the output signal lines in the Waveform Display Area. *Fig3-153* presents how to change colors of a signal or some signals. Repeat the following procedures if users need to change colors of many signals.

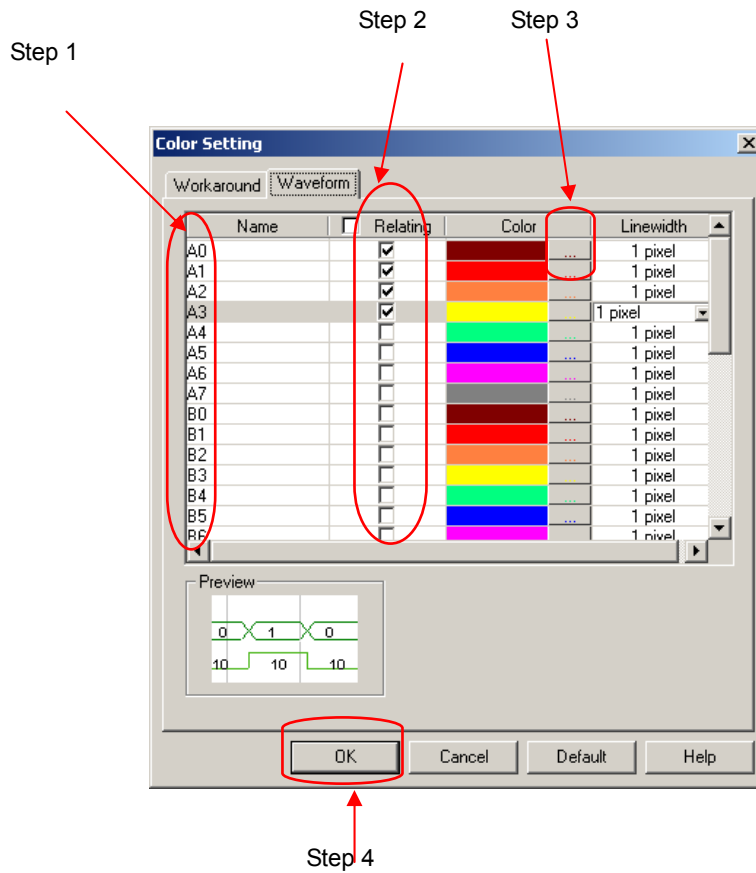

Fig 3-153: Stepwise Illustration of Changing **Waveform** Colors

Step 1: Select several **Optional Items**.

Step 2: Select the corresponding items in the relating.

Step 3: Choose a color by following the method shown in Fig 3-153.

Step 4: Click **OK** to change their colors into the same, for example A0, A1, A2 and A3.

Here is a sample of an altered Logic Analyzer software interface which will be used for further demonstrations in subsequent chapters. See *Fig 3-154*.

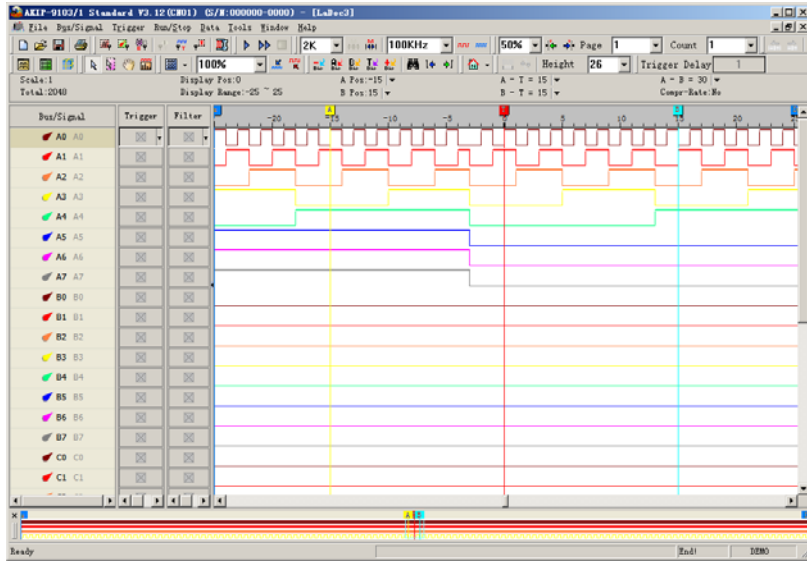

Fig 3-154: An Altered Interface Sample

3.7 The Flow of Software Operation

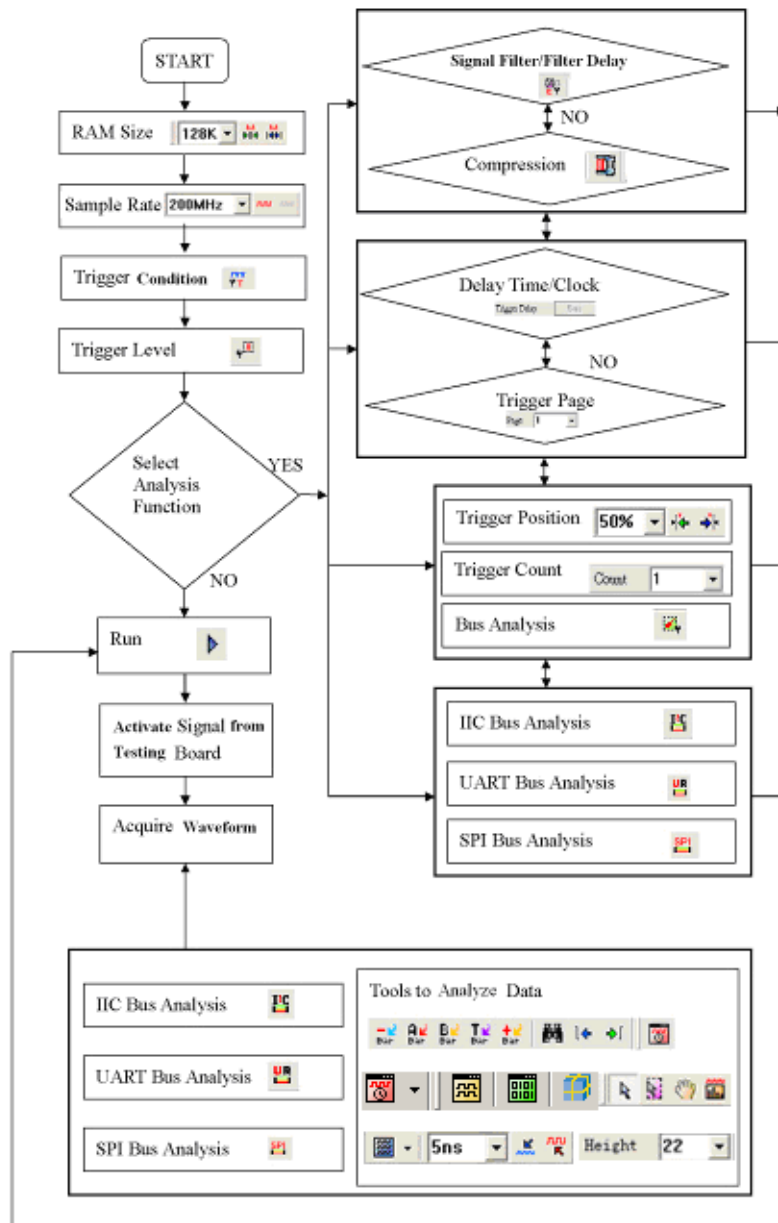

Fig 3-155: Software Flow Diagram

Conclusion

Information demonstrated in this chapter is only for entrance level. There are more advanced approaches which may require fewer steps than those shown in this chapter. This chapter is meant to equip users with sufficient grounding of the Logic Analyzer's software interface.

4 Introduction to Logic Analysis

- 4.1 Logic Analysis
- 4.2 Bus Logic Analysis
- 4.3 Plug Analysis
- 4.4 Bus Packet List
- 4.5 Bus Analysis
- 4.6 Compression
- 4.7 Signal Filter and Filter Delay
- 4.8 Noise Filter
- 4.9 Data Contrast
- 4.10 Refresh Protocol Analyzer
- 4.11 Multi-stacked Logic Analyzer Settings
- 4.12 DSO-stacked Settings
- 4.13 Memory Analyzer

Objective

Chapter 4 gives detailed instructions on performing two basic analysis operations and other advanced analysis applications with the Logic Analyzer. These two basic analysis operations are the Logic Analysis and the Bus Logic Analysis, which are fundamental to all further applications. The other advanced analysis applications are the I2C (Inter Integrated Circuit) Analysis, the UART (Universal Asynchronous Receiver Transmitter) Analysis, the SPI (Synchronous Peripheral Interface) Analysis, Compression, Signal Filter Setup, Filter Delay Setup, etc..

4.1 Logic Analysis

Logic Analysis is meant for a single signal analysis. Section 4.1 gives detailed instructions on the software's basic setup.

Basic Software Setup of the Logic Analysis

Task 1. Clock Source (Frequency) and RAM Size Setup

Step1. Click  icon or click Sampling Setup from Bus/Signal on the menu bar, the dialog box as shown in Fig 4-1 will appear.

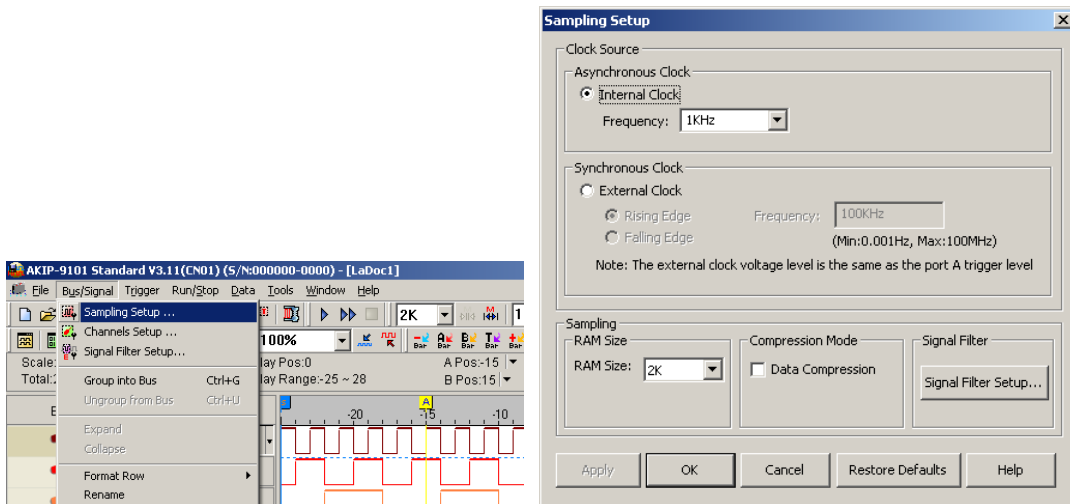



Fig 4-1 - Clock Source

Step 2. Clock Source (Frequency) Setup

Internal Clock (Asynchronous Clock)

Click on **Internal Clock**, and then select the Frequency from the pull-down menu to set up the frequency of the device under test (DUT). The frequency of the Internal Clock must be at least four times higher than the frequency of the Oscillator on the DUT. Or, select the frequency  from the pull-down menu on Tool Bar as Fig 4-2 shows.

Tip: Connect the output pin of the oscillator from the tested board to the signal connector of the Logic Analyzer to measure it by using the internal clock of the Logic Analyzer.

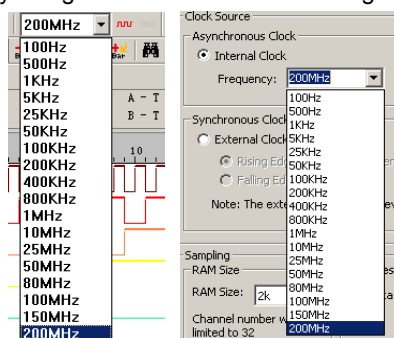



Fig 4-2 – Clock Source Pull-down Menu

External Clock (Synchronous Clock)

Click on **External Clock**, and then select “Rising Edge” or “Falling Edge” as the trigger condition of the DUT. In the Frequency column, type the frequency of the oscillator on the DUT.

Tip: The External Clock is applied when the frequency of the oscillator on the tested board is exceeds the range of the internal clock of the Logic Analyzer. Connect the output pin of the oscillator on the tested board to the CLK pin of the Logic Analyzer.

Step 3. RAM Size Setup

Click on the RAM Size  from the pull-down menu on the Sampling Setup dialog box as shown in Fig 4-3.

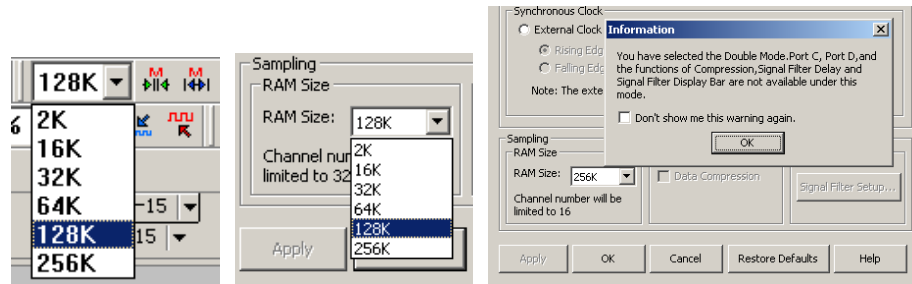



Fig 4-3 – RAM Size

The relationship between RAM Size, Signal Filter Mode, Compression Mode and Channels as shown in Table 4-1 and Fig 4-3.

Table 4-1 RAM Size vs. Signal Filter Mode, and RAM Size vs. Compression Mode and Channels

Status	Normal Mode			Double Mode		
	RAM Size/ Channels	Channels Available	Compression Mode & Signal Filter Mode	RAM Size/ Channels	Channels Available	Compression Mode & Signal Filter Mode
AKIP-9101	2K ~ 128K	16 channels	Available	256K	16 channels	Disable
AKIP-9102	2K ~ 128K	32 channels	Available	256K	16 channels	Disable
AKIP-9103	2K ~ 1M	32 channels	Available	2M	16 channels	Disable
AKIP-9103/1	2K ~ 2M	32 channels	Available	4M	16 channels	Disable

Task 2. Trigger Property

Step1. Click  icon or click **Trigger Property** from the Trigger on the Menu Bar. The dialog box will appear as shown in Fig 4-4.

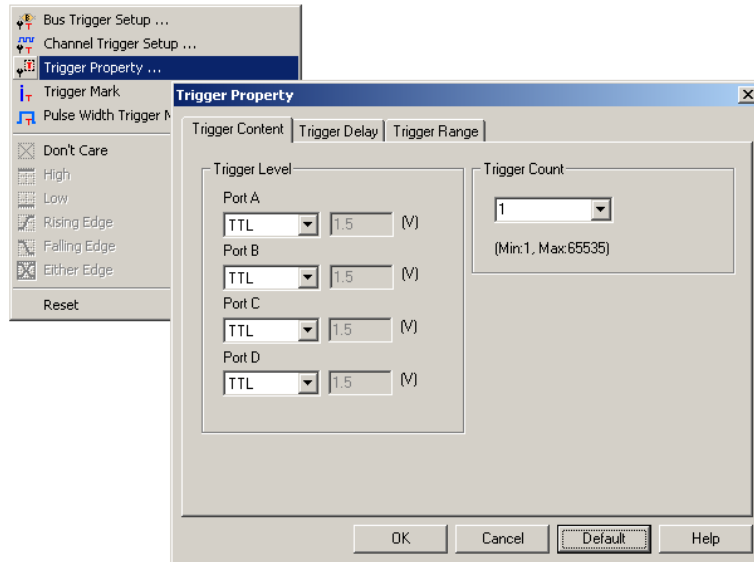

Fig 4-4 - Trigger Property

Step2. Trigger Level Setup

Click the pull-down menu of **Trigger Level** on Port A, B, C and D to select the Trigger Level as the voltage level that a trigger source signal must reach before the trigger circuit initiates a sweep.

Tip: There are four commonly used preset voltages for Trigger Level, TTL, CMOS (5V), CMOS (3.3V), and ECL. Users also can define their own voltage from -6.0V to 6.0V to fit with their DUT. Port A represents the pins from A0 ~ A7 on the signal connector of the Logic Analyzer, and so do Port B, C and D. The voltage of each port can be configured independently.

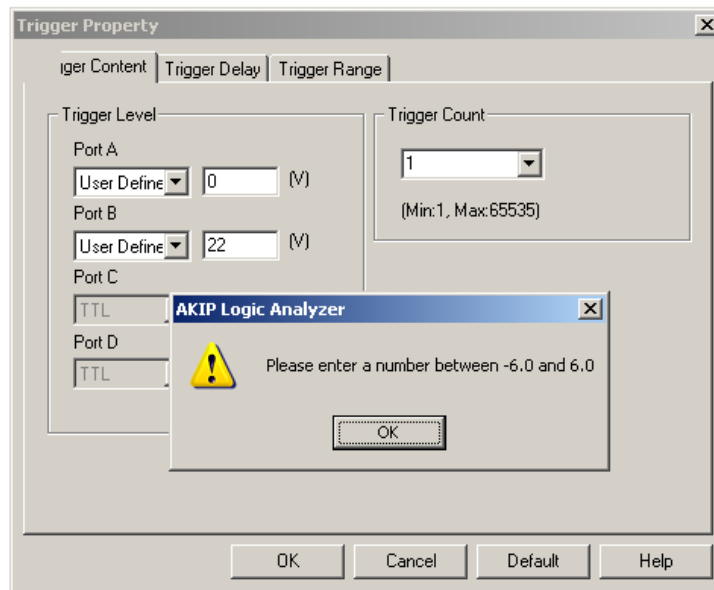

Fig 4-5 – Trigger Level Error

Step3. Trigger Count.

Type the numbers or select the number from the pull-down menu of the Count Count 1 on the Tool Bar or click the pull-down menu of the **Trigger Count** on the Trigger Property dialog box as shown in Fig 4-6.

The system will be triggered at the position where the Trigger Count is set as shown in Figs 4-6, 4-7 and Fig 4-8.

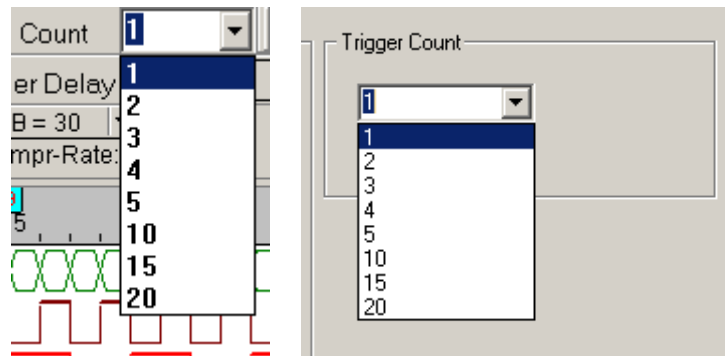

Fig 4-6 – Trigger Count Pull-down Menu

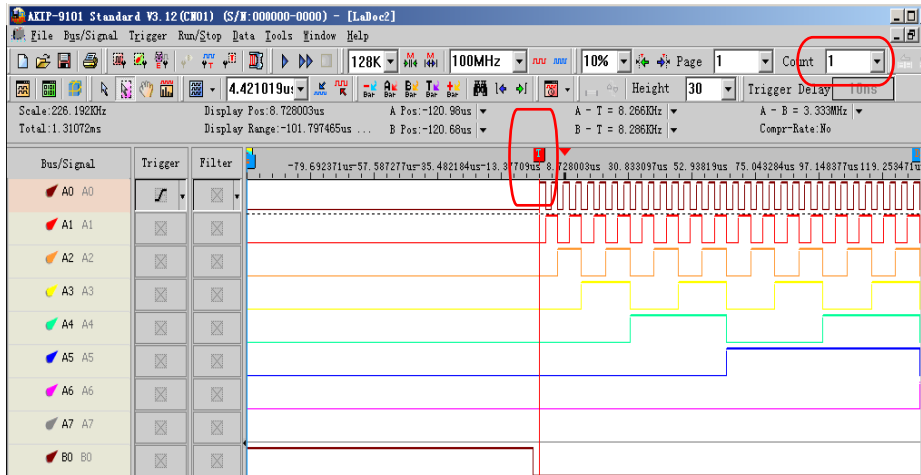

Fig 4-7 – Trigger Count Screen Shot 1

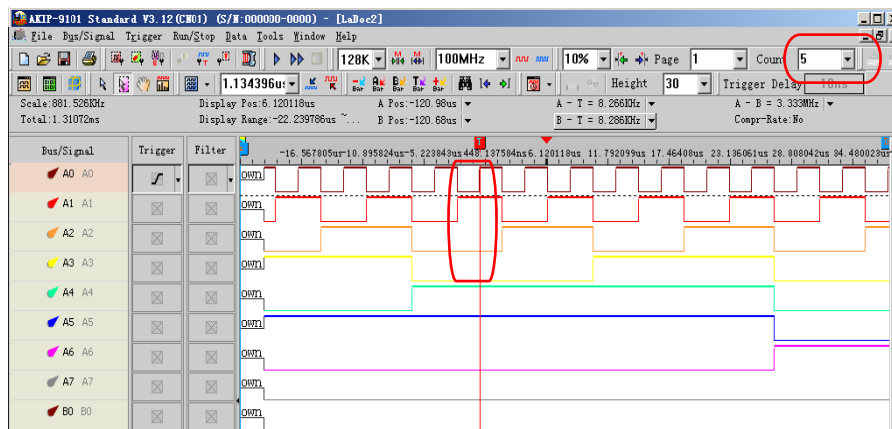

Fig 4-8 – Trigger Count Screen Shot 5

Step4. Trigger Page/ Delay Time and Clock

The Trigger Page, the Delay Time and Clock can't be applied at the same time.

1. Trigger Page:

Click **Trigger Page**, then type the numbers or select the numbers from the pull-down menu of the Page on the Tool Bar or click the pull-down menu of the Trigger Page on the "Trigger Delay" page of the Trigger Property dialog box as shown in Figs 4-9, 4-10 and 4-11. The selected page numbers will be displayed on the screen.

Tip: The Trigger Bar (T Bar) will not be displayed when the setup of the Trigger Page is more than 1.

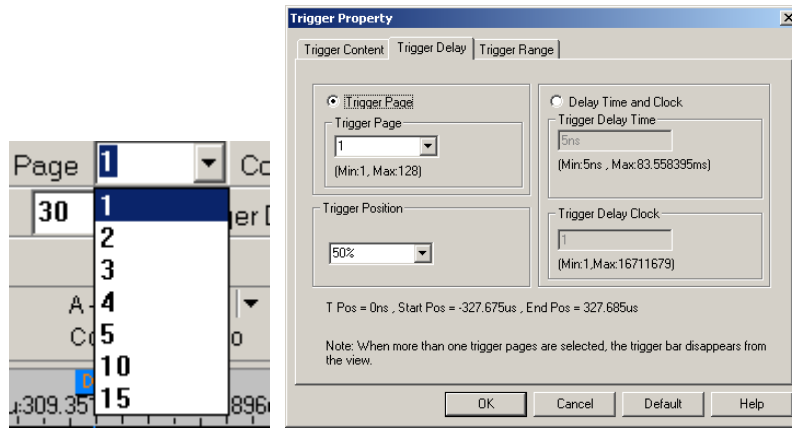

Fig 4-9 – Trigger Page

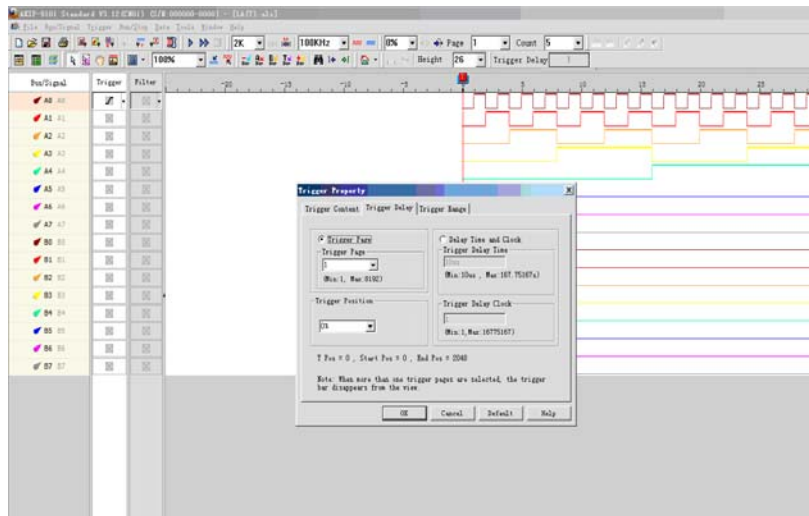

Fig 4-10 – Trigger Page and Screen (1)

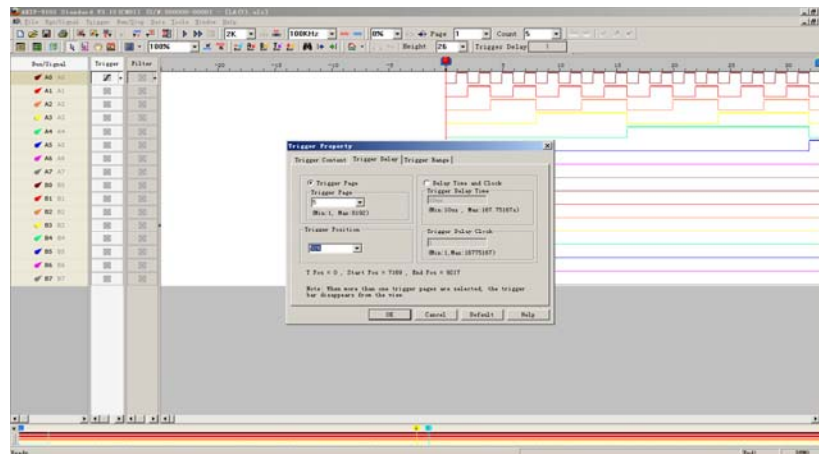

Fig 4-11 – Trigger Page and Screen (2)

2. Delay Time and Clock

Click the **Delay Time and Clock**, then type the numbers into the column of the Trigger Delay Time or type numbers into the Trigger Delay Clock at the “Trigger Delay” page of the Trigger Property dialog box as shown in Fig 4-11. Or type the numbers into the column of Trigger Delay **Trigger Delay** 5 on the Tool Bar. The system will display the Start of the waveform.

Tip: The formula of Delay Time and Clock is “Trigger Delay Time = Trigger Delay Clock * (1/ Frequency)”. To use the compression mode, the < Delay Time and Clock > will be unavailable.

Step5. Trigger Position Setup

Type the percentages or select the percentages from the pull-down menu of the **20%** on the Tool

Bar or click the pull-down menu of the Trigger Position on the “Trigger Delay” page of the Trigger Property dialog box as shown in Figs 4-12, 4-13, 4-14 and 4-15. The selected Trigger Position percentages will be displayed on the right side of the screen of the system.

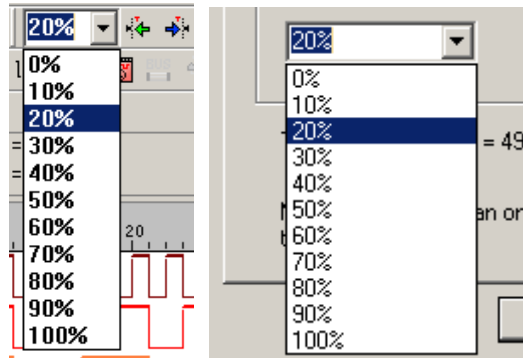

Fig 4-12 – Trigger Position Pull-down Menu

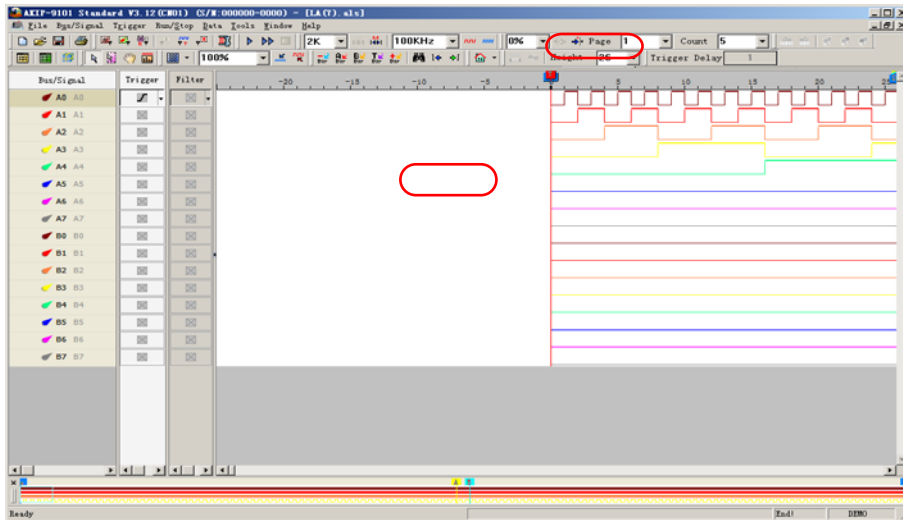

Fig 4-13 – Trigger Position 0%

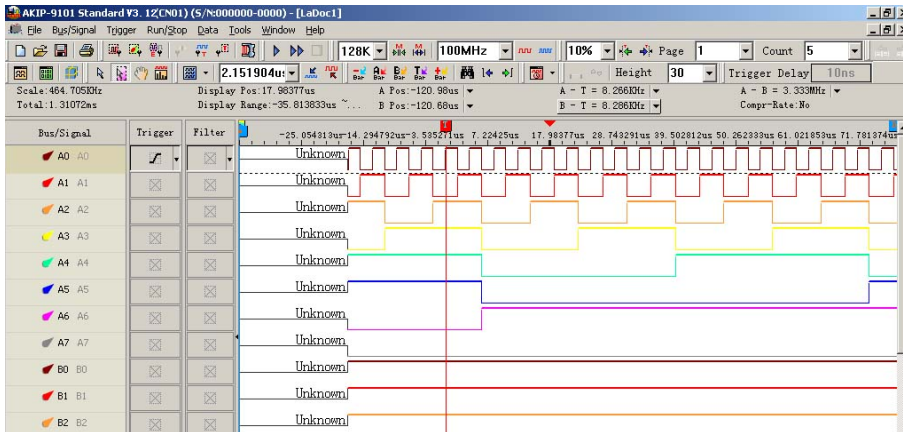

Fig 4-14 – Trigger Position 10%

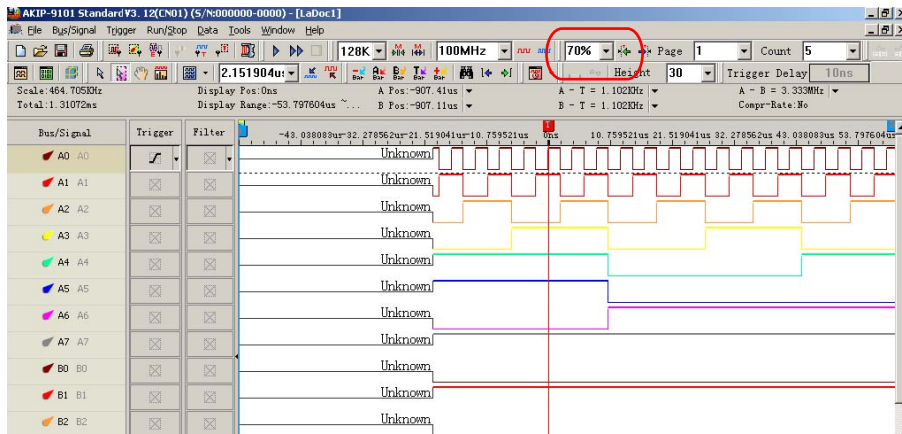

Fig 4-15 – Trigger Position 70%

Step6. Trigger Range Setup

Click icon or click **Trigger Property** from the Trigger on the Menu Bar. Then, Click the Trigger Range, the dialog box will appear as shown in Fig4-16.

Tip: This function is mainly for the range control for the saved files after triggering. According to the procedures of the range control, users can start the save of data according to the requirement of its time and times to get the standard of data statistic status.

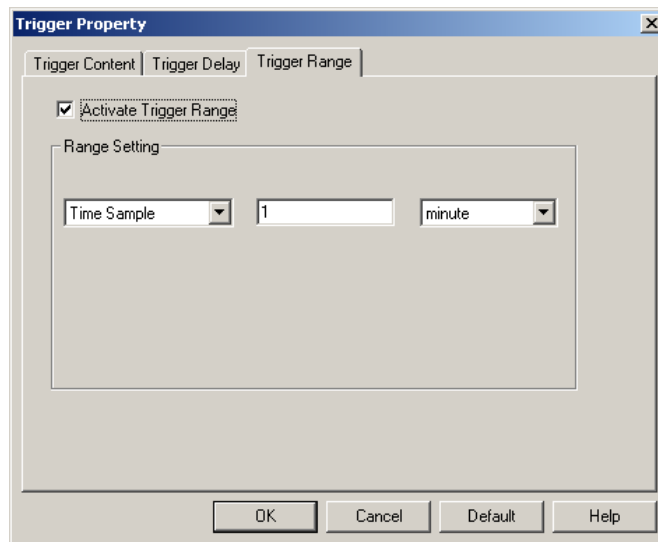

Fig 4-16 - Trigger Range

1. Trigger Range: The default is not activated.
2. There are “Time Sample” and “Frequency Sample” in the part of Range Setting; the default is “Time Sample”. The units of Time Sample are ‘second’, ‘minute’, ‘hour’ and ‘day’. The unit of Frequency Sample is ‘times’. Users can set the value by themselves in the editor box.

Task 3. Bus Trigger and Trigger Mark Setup

Step1. Click icon or click Bus Trigger Setup on the Trigger menu to open the Bus Trigger dialog box. The Trigger menu is shown as Fig 4-17.

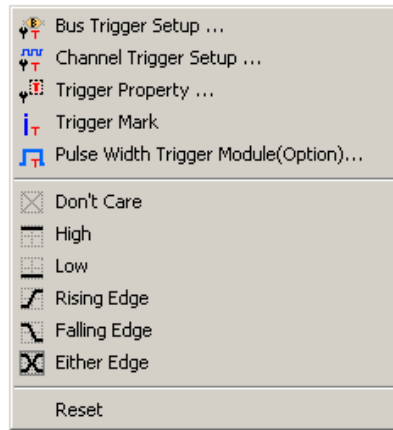

Fig 4-17 -Trigger Menu

Step2. Bus Trigger Setup

1. Bus Trigger Setup

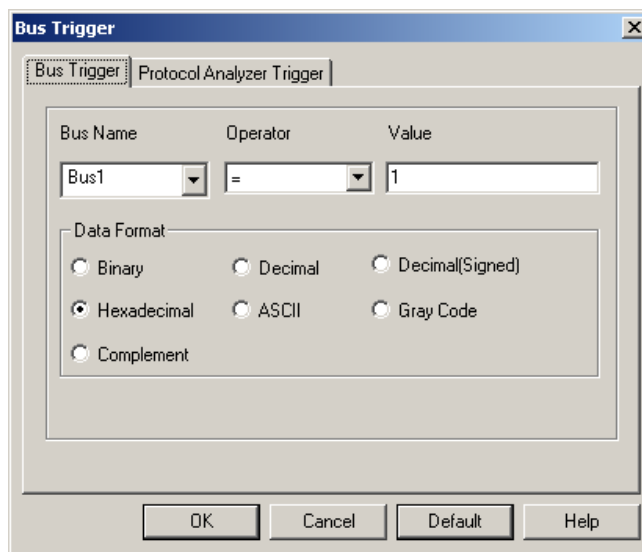

Fig 4-18 - Bus Trigger Dialog Box

Tip: The Bus Name item can be selected from the pull-down menu (It only displays the Bus name), and also the Decimal(Signed), Gray Code and Complement Modes are added.

2. Protocol Analyzer Trigger Setup

Tip: This function can be used in the Modules, AKIP-9101, AKIP-9102, AKIP-9103 after registering, and for the AKIP-9103/1, it is not necessary to register as they can be used for free. Before registering, the button “OK” in the Protocol Analyzer Trigger dialog box is the button, “Register”; when users press this button, Register, a Register dialog box will pop up. Then users need to enter the correct Register Code so that they can use this function, Protocol Analyzer Trigger.

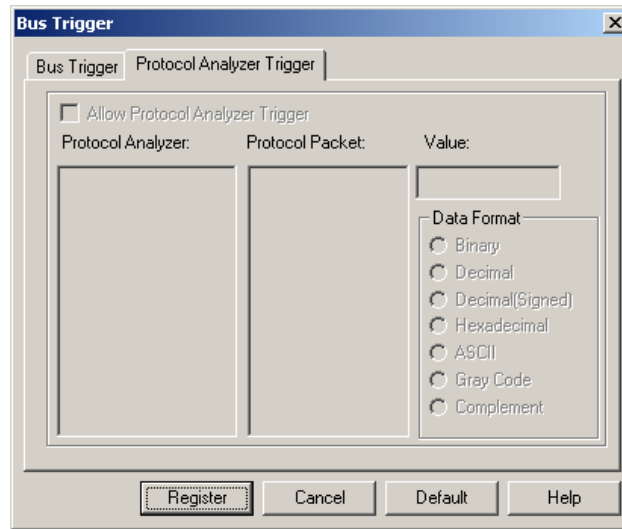

Fig 4-19-1 Before Registering

Register Dialog Box:

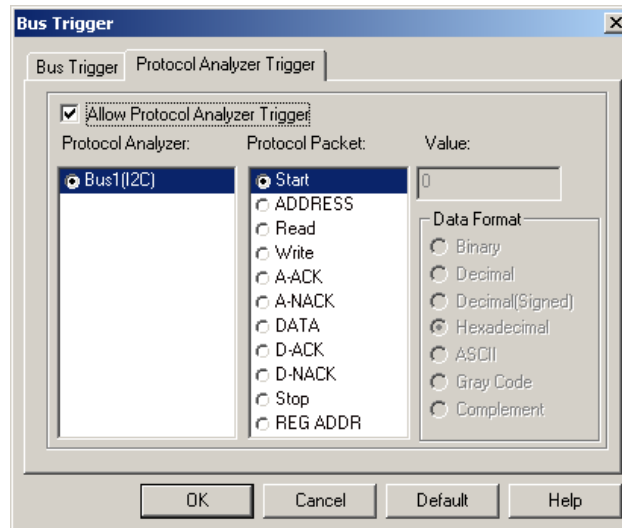
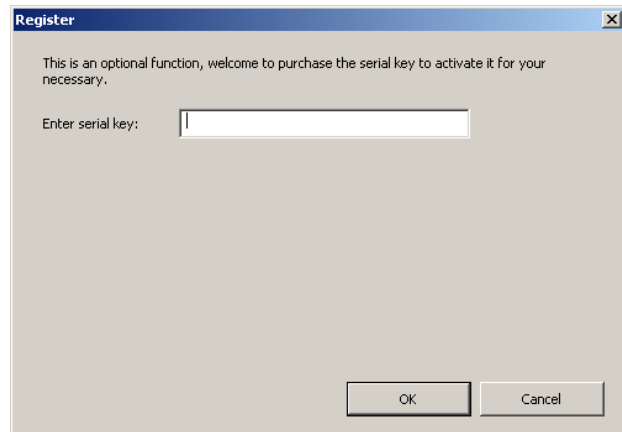

Fig 4-19 -2 After Registering

Allow Protocol Analyzer Trigger: When it is selected, the Protocol Analyzer Trigger function is activated. And then users can set Protocol Analyzer, Protocol Packet, Value and Data Format.

Protocol Analyzer: It only displays the name of Protocol Analyzer and only one name can be selected.

Protocol Packet: It is displayed according to the packet in every Protocol Analyzer.

Value: The value needs to be entered in the frame, and the data mode can be selected by users according to their

requirements; the default is Hexadecimal! When a value can be input in the selected protocol analyzer data, the frame can be enabled! Or, the frame will be disabled! For example: Protocol Analyzer I2C, when the protocol packet is DATA, the frame can be used; to the contrary, when the protocol packet is START, the frame is disabled.

Data Format: The displayed value mode can be selected! There are five options: Binary, Decimal, Decimal(Signed), Hexadecimal , ASCII, Gray Code and Complement.

Step3. Trigger Mark Setup

To find the item in the Bus better, users can activate the Trigger Mark function after starting Bus Trigger; the trigger mark is shown with T Bar. According to the number of the trigger position, the T Bar is displayed in order T0, T1, T2, T3, T4...and the color is red as the image below:

1. Bus: The trigger condition is "0"; the red T Bar displays the trigger condition in order.

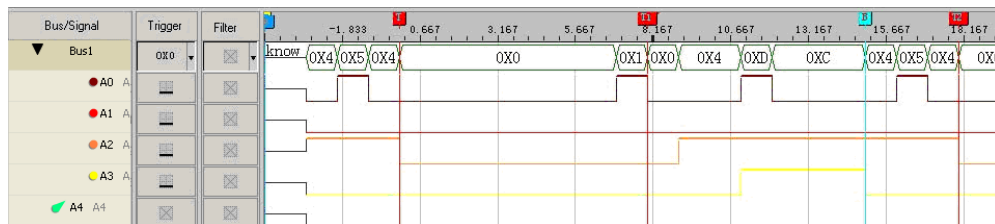

Fig 4-20 - Bus Trigger Mark

2. Protocol Analyzer (I2C): The trigger condition is "Data=0"; the red T Bar displays the trigger condition in order.

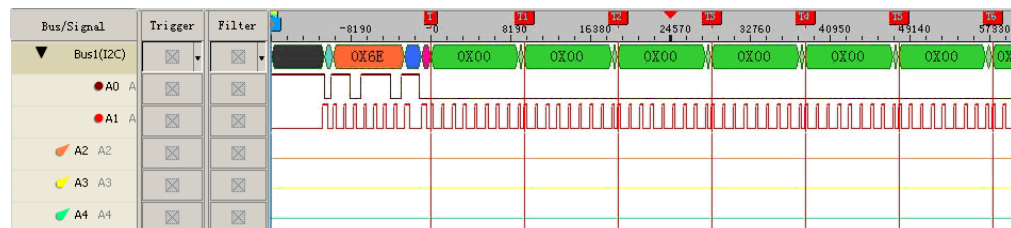

Fig 4-21 - Protocol Analyzer Trigger Mark

Tip: The Trigger Mark function is available for the AKIP-9103, AKIP-9103/1Modules, and it is not available for the AKIP-9101, AKIP-9102.

Task 4. Bus/Signal Trigger Condition Setup

Highlight a designated signal, and then set its required trigger condition.

1. Left click to set the signal trigger condition as shown in Fig 4-22.
2. Right click to set the signal trigger condition as shown in Fig 4-23.
3. Click **Trigger** on the Menu Bar and choose a trigger condition from the list of triggers as shown in Fig 4-24.



Fig 4-22 – Left Click on Trigger

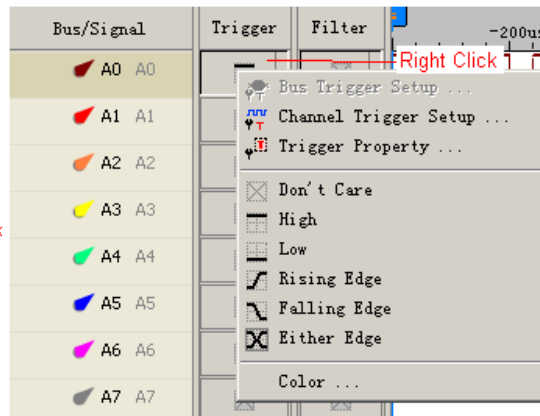

Fig 4-23 – Right Click on Trigger

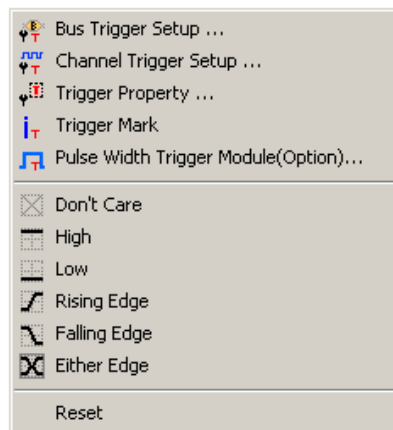





Fig 4-24 – Trigger Menu

Task 5. Run to Acquire Data

1. Single Run

Click the Single Run  icon from the Tool Bar or press **START** button on the top of the Logic Analyzer (or press F5), then activate the signal from the DUT to the Logic Analyzer to acquire the data shown in the waveform display area.

2. Repetitive Run

Click the Repetitive Run  icon from the Tool Bar, then activate continuous signal to the Logic Analyzer to acquire the repetitive data, and then click the Stop  icon to end the repetitive run.

Tip: Click  icon to view all the data, and then select the waveform analysis tools to analyze the waveforms.

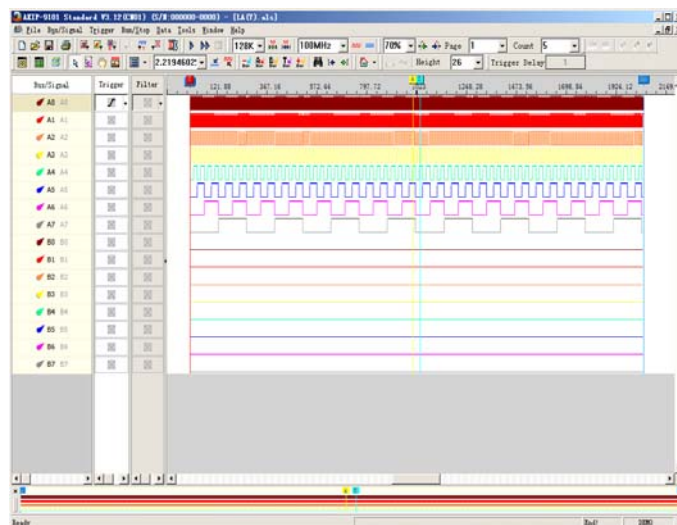



Fig 4-25 – Click  Icon to View All the Data

3. Stop to end Run

Click the Stop  icon to end the Run.

Tip: If the status is “Waiting...” with no signal outputting as shown in Fig 4-26, click the Stop  icon to end the Run; check the setup again, and try the run process again.

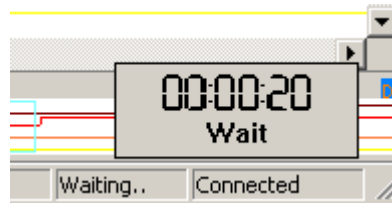

Fig 4-26 – Waiting Status

4.2 Bus Logic Analysis

Section 4.2 presents detailed instructions about logic analysis with a set of grouped signals, which is known as Bus Logic Analysis.

Basic Software Setup of the Bus Logic Analysis

Step1. Set up the RAM Size, Frequency, Trigger Level and Trigger Position as described in Section 4.1.

Step2. Group signals into a Bus

Click **Channels Setup** on Bus/Signal of the menu bar, or click  icon.

The dialog box shown in Fig 4-27 will appear.

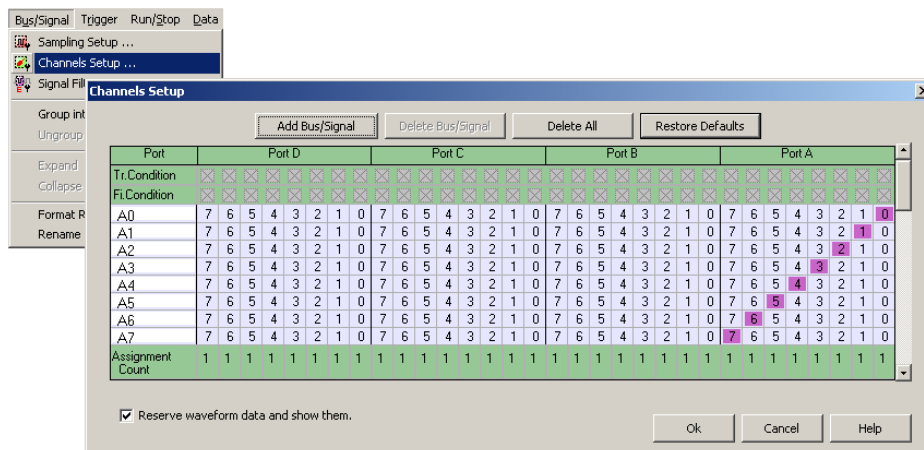

Fig 4-27 – Channels Setup

Rename the Bus and set up the channels of the Bus as shown in Fig 4-28.

Port	Port				Port A			
Tr.Condition	X	X	X	X	X	X	X	X
Fi.Condition	X	X	X	X	X	X	X	X
A0	7	6	5	4	7	6	5	4
A1	7	6	5	4	7	6	5	4
A2	7	6	5	4	7	6	5	4
A3	7	6	5	4	7	6	5	4
Bus1	7	6	5	4	7	6	5	4
A5	7	6	5	4	7	6	5	4
A6	7	6	5	4	7	6	5	4
A7	7	6	5	4	7	6	5	4
Assignment Count	1	1	1	1	1	1	1	0

Fig 4-28 – Rename Bus

1. Click the column with blue, then type the given name of the Bus, and then press **Enter** to confirm it.
2. Go to the relative channels as shown in the example and go to numbers 0, 1, 2, 3, which are located on column A and row Bus1. Click them to become purple, then set these segments of channels.
3. Click **OK** to get the result as shown in area 1.

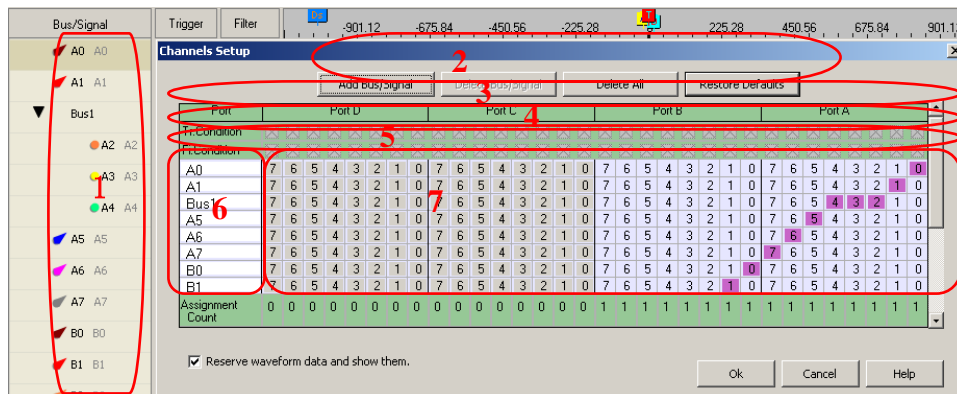

Fig 4-29 – Channels Setup Window

Tip: Channels Setup

In the dialog box of Channels Setup, there isn't only Add Bus/Signal, but also Delete Bus/Signal, Delete All, Restore Defaults provided.

1. Delete Bus/Signal: Firstly highlight the Bus or channels on area 6 of Fig 4-29, then click **Delete Bus/Signal** to delete them.
2. Delete All: Click **Delete All** to delete all Bus/signals on area 6 of Fig 4-29.
3. Restore Defaults: Click **Restore Defaults** to restore the dialog box of Channels Setup as shown in Fig 4-27.

Step3. Trigger Condition Setup

1. Highlight the Bus which will be triggered then click  icon or select **Bus Trigger Setup** from the Trigger of the Menu Bar, the dialog box as shown in Fig 4-30 will appear.

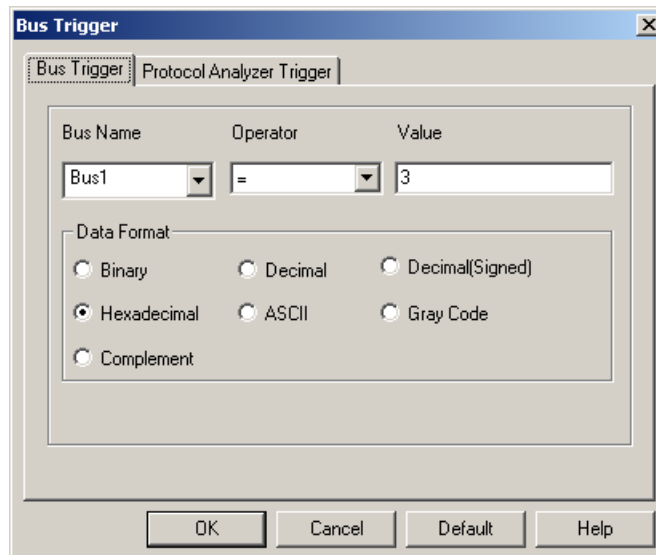

Fig 4-30 – Bus Trigger Setup

Tip: Left click on Trigger column of the Bus as shown in Fig 4-31.

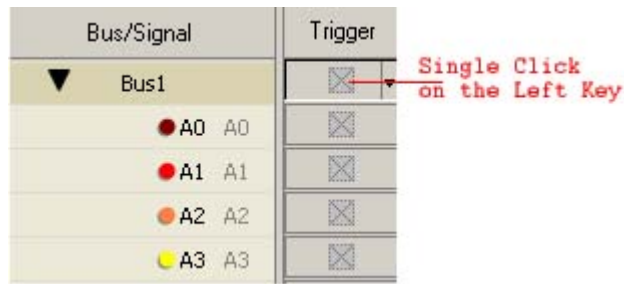



Fig 4-31 – Trigger Column

2. Set Binary, Hexadecimal, Decimal, Decimal (Signed), ASCII, Gray Code or Complement as the Data Format of the Bus to represent the value (see Fig 4-30).
3. Set “=” and “Don't Care”, and type the value of the Bus into Value column to set the trigger condition of the Bus.
4. Click **OK** to confirm the settings.

Step4. Click **Run** and activate the signal from the tested board to the system to get the result as shown in Fig 4-32.

Tip: Click  icon to view all data, and then select the waveform analysis tools to analyze the waveforms. Set **Value** is “2” as Hexadecimal, and set **Operator** equals to “=”, then click **OK**. Click **Run** and activate the signal from the tested board to the system to get the result as the trigger happens on 0X2.

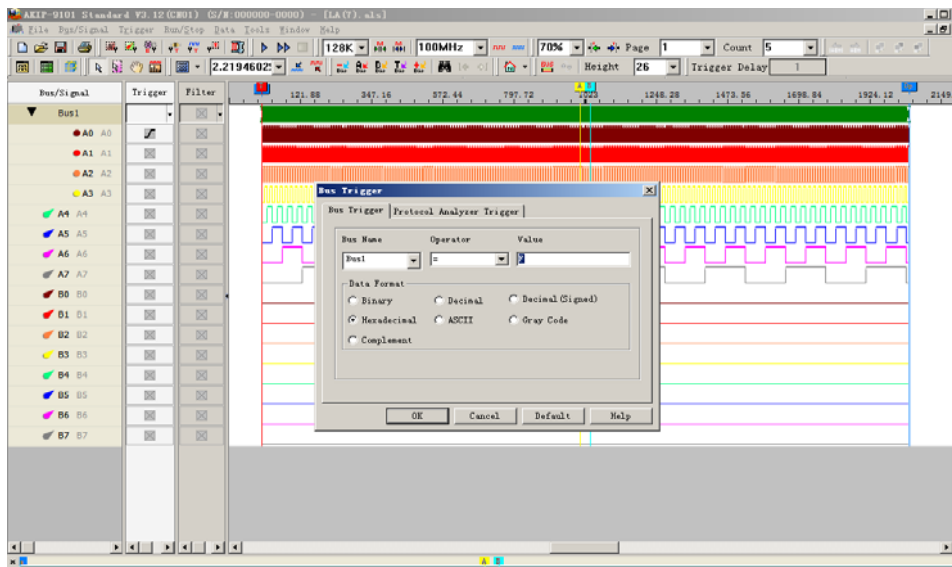

Fig 4-32 – Bus Trigger Setup

4.3 Plug Analysis

Plug Introduction

Protocol Analyzer operates in the form of Plug; every Protocol Analyzer has a plug, per plug is independence modularization. One Protocol Analyzer plug can analyze many Buses at the same time, however, because the independence of every plug, the Protocol Analyzer plug only supports I2C, UART, SPI, HDQ, 1-WIRE, CAN 2.0B at present. In the future, it will support more Buses, and when the Protocol Analyzer renews, it only needs to download the new Protocol Analyzer plug to cover the old Protocol Analyzer plug; the speed is very fast.

Operating Instructions: There are PlugIns data file in the position of installing LA software. All Protocol Analyzer plugs which are used at present are put in the data file, the DLL file can be added or deleted in the content, and in the Bus property, all Protocol Analyzer plugs that can be used at present can be seen as the figure below:

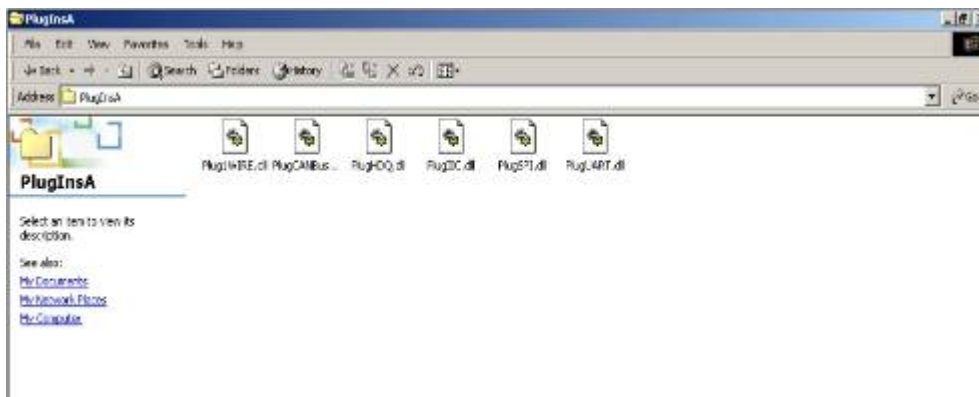

Fig4-33 - PlugInsA

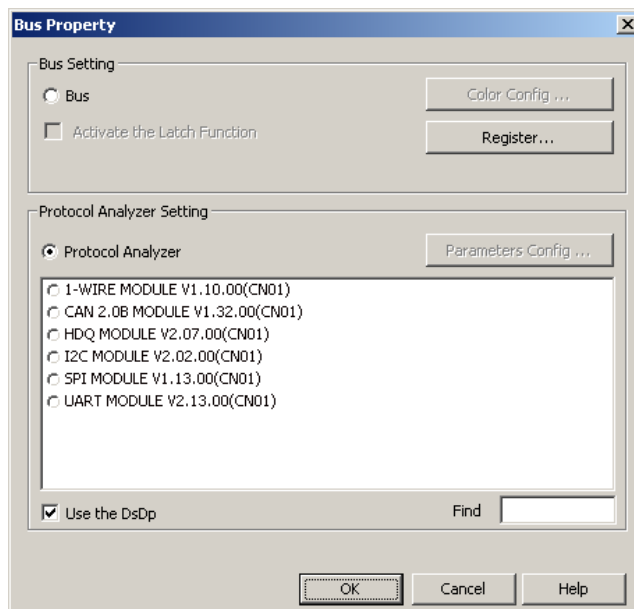

Fig4-34 - Bus Property

Every Logic Analyzer Module can provide some basic Protocol Analyzer plugs. When users need to use the analysis which is not provided by the basic Protocol Analyzer plugs, you can purchase from our company, and then, you can get this Protocol Analyzer plug and the register code.

STEP 1. Put the CAN 2.0B Plug in the PlugIns as the Fig4-35.

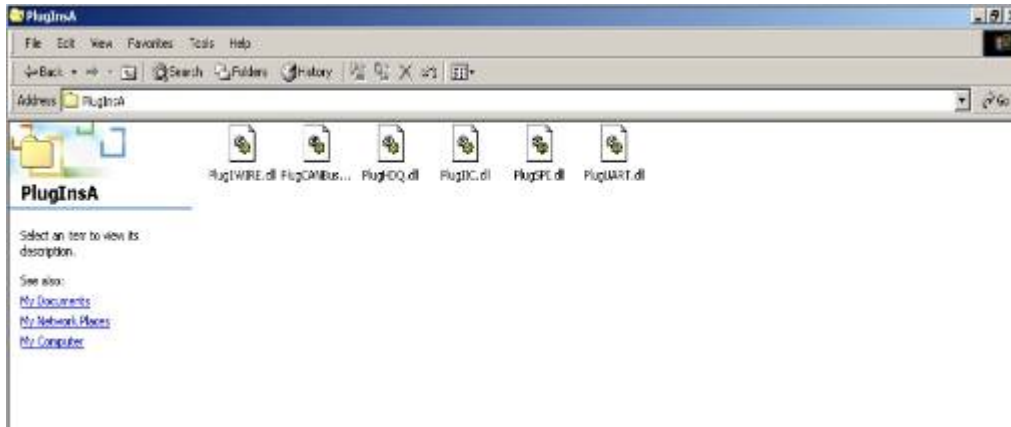

Fig4-35 - PlugInsA

STEP 2. Select CAN 2.0B in the Protocol Analyzer list.

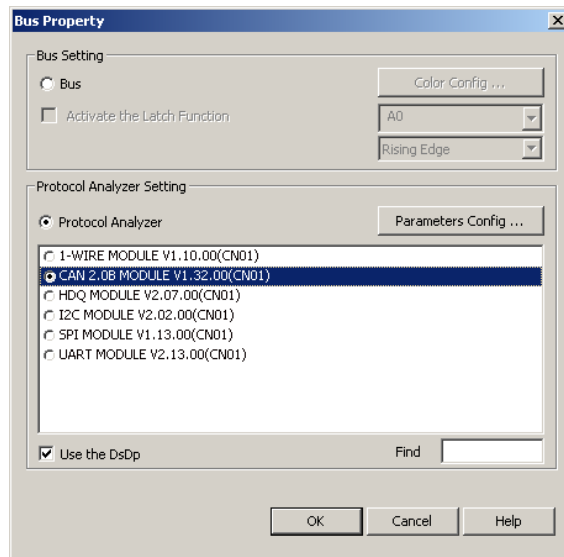

Fig4-36 - Bus Property

STEP 3. Click **Parameters Configuration** button, select **Register** and enter the Serial Key.

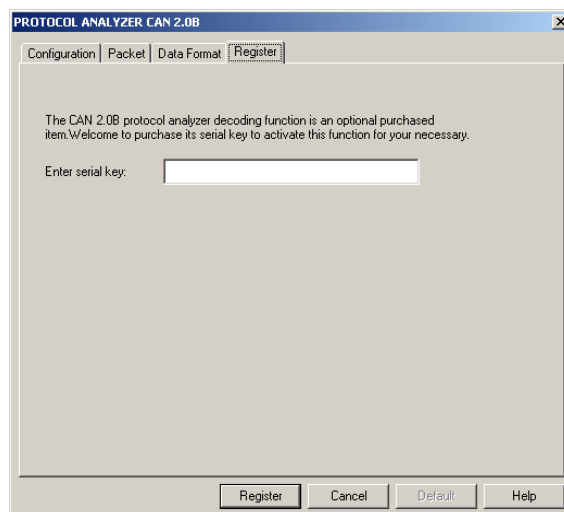

Fig4-37 - Protocol Analyzer CAN 2.0B Register dialog box

4.4 Bus Packet List

Bus Packet List is a graphics list which is used for doing Statistics and showing Bus Packet List. It is visual and direct, especially for I2C, USB 1.1 and CAN 2.0B. When there is a packet list, it gets twice the result with half the effort to check the data. Packet List has its startup button in Toolbar. After starting it, it will show a small window under the waveform window. Users can alter its size to find more data.

Notice: If you want to learn more about the Bus Packet List, please refer to the Specification of the Protocol Analyzer.

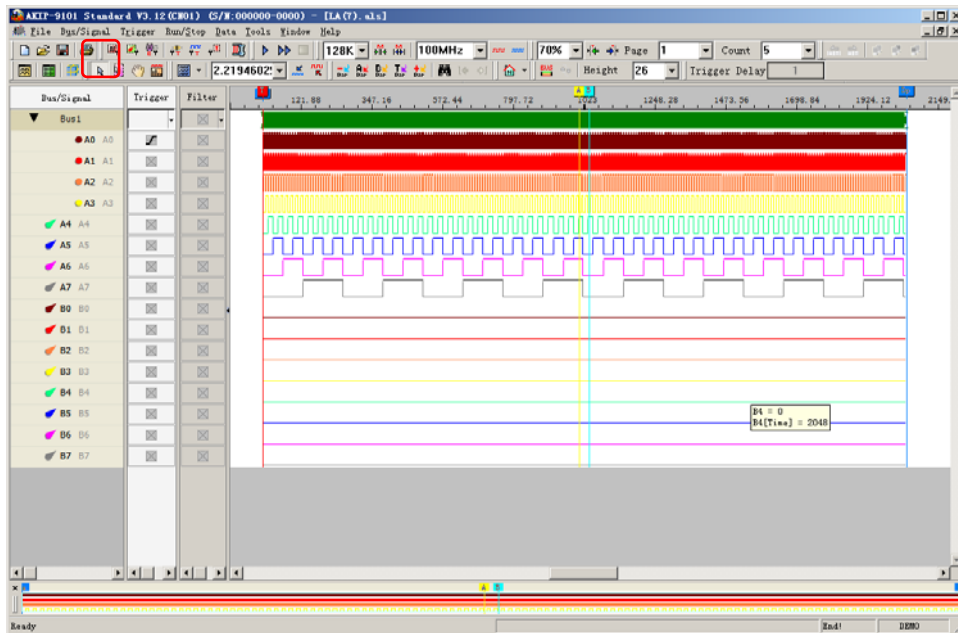

Fig 4-38 - Packet Icon

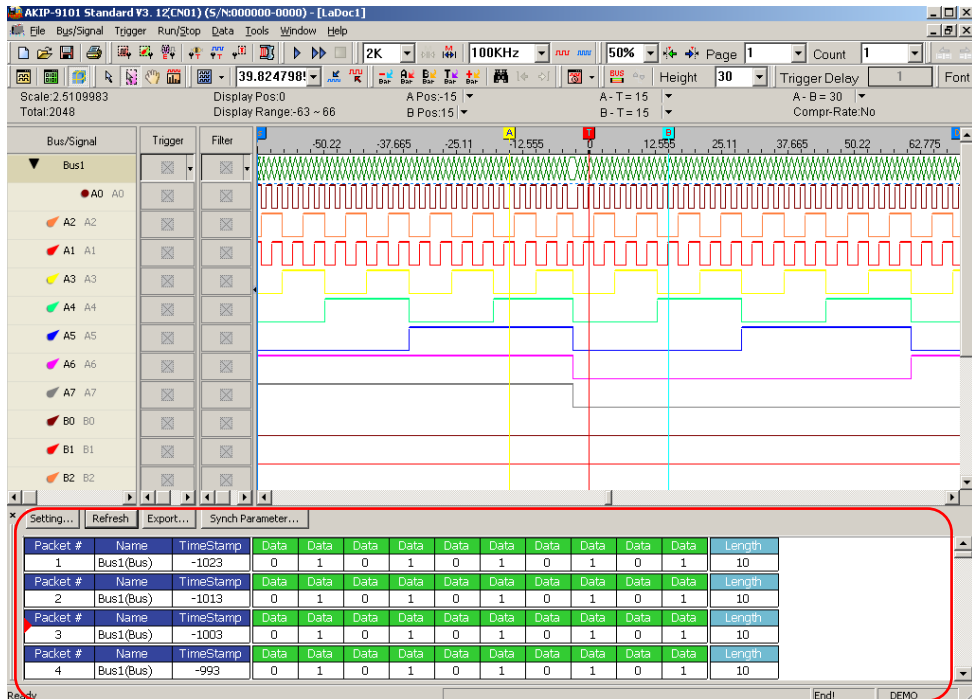

Fig4-39 - Bus Packet List

Packet List has a setup window; users can set up the Packet List according to their requirements. Setting

Bus Packet Length in dialog box is only used for doing Bus Statistic. Users can define how long the time is as a data packet to add the export function. See the following figure.

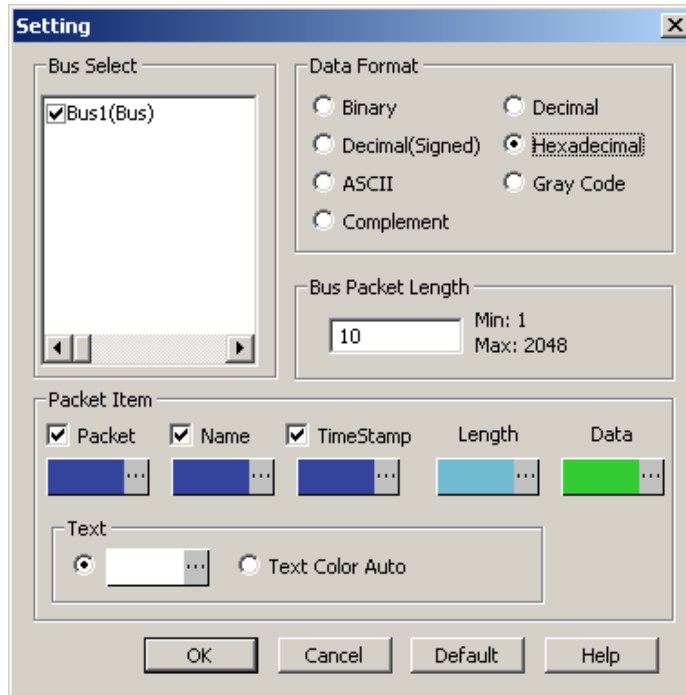

Fig4-40 - Packet List Setting

Packet #	Name	TimeStamp	Data	Data	Data	Data	Data	Data	Data	Data	Data	Data	Data	Length
1	Bus1(Bus)	-1023	0	1	0	1	0	1	0	1	0	1	10	
2	Bus1(Bus)	-1013	0	1	0	1	0	1	0	1	0	1	10	
3	Bus1(Bus)	-1003	0	1	0	1	0	1	0	1	0	1	10	
4	Bus1(Bus)	-993	0	1	0	1	0	1	0	1	0	1	10	
5	Bus1(Bus)	-983	0	1	0	1	0	1	0	1	0	1	10	
6	Bus1(Bus)	-973	0	1	0	1	0	1	0	1	0	1	10	
7	Bus1(Bus)	-963	0	1	0	1	0	1	0	1	0	1	10	

Fig4-41 - Bus Packet List

1. View Specifications

Packet #, Name and TimeStamp can be selected to display from the Packet List Setting dialog box.

Packet #: List the order of Packet.

Name: Display the name of Packet, or the Filter Display Bar.

TimeStamp: It is the starting point of the Packet.

Tip: The rest name and content are supplied by Plug.

Packet #	Name	TimeStamp	Address	Read	A-NACK	DESCRIBE
1	IIC BUS(I2C)	477	7F	Read	A-NACK	ADDR NACK
2	IIC BUS(I2C)	5231	7F	Read	A-NACK	ADDR NACK
3	IIC BUS(I2C)	9165	7F	Read	A-NACK	ADDR NACK
4	IIC BUS(I2C)	16367	7F	Read	A-NACK	ADDR NACK
5	IIC BUS(I2C)	20290	7F	Read	A-NACK	ADDR NACK

Fig4-42 - Protocol Analyzer I2C Packet List

Setting: It is used to open Packet List Setting dialog box.

Refresh: Press this button, the list view can renew automatically.

Export: Export the workspace into Text (*.txt) and CSV Files (*.csv).

Synch Parameter: Open the synch parameter setting dialog box and activate the packet and waveform synch function.

2. Display Protocol Analyzer Packet in Order

Tip: The below view are Protocol Analyzer I2C; the packet is determined by the position of the TimeStamp.

Packet #	Name	TimeStamp	Address	Read	A-NACK	DESCRIBE
1	IIC BUS(I2C)	477	7F	Read	A-NACK	ADDR NACK
2	IIC BUS(I2C)	5231	7F	Read	A-NACK	ADDR NACK
3	IIC BUS(I2C)	9165	7F	Read	A-NACK	ADDR NACK
4	IIC BUS(I2C)	16367	7F	Read	A-NACK	ADDR NACK
5	IIC BUS(I2C)	20290	7F	Read	A-NACK	ADDR NACK

Fig4-43 - TimeStamp

Tip: When the Display Bar of Signal Filter is activated, the Bar should be displayed in the Bus Packet List, and also the TimeStamp, Address and length of the Bar will be displayed.

3. Packet Idle and Packet Length

Packet Idle: Packet interval time

Packet Length: Packet time length

When those above two items are to be displayed, it only chooses one of them to display, which is controlled by Plug.

Because it is impossible that every Protocol Analyzer packet has registered timestamp and end, we add two special Unknow_Flag to judge the timestamp and end of the packet which are Unknow_Start_Flag and Unknow_End_Flag.

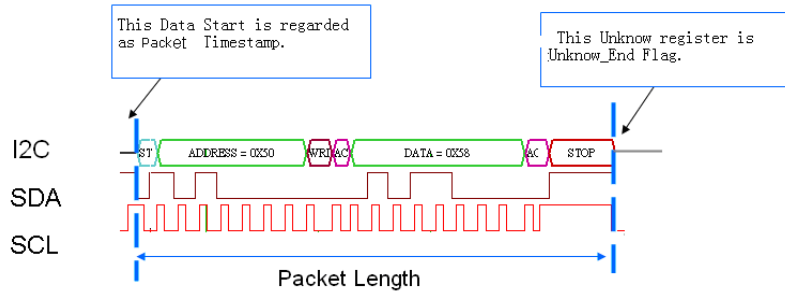

Fig4-44 - Protocol Analyzer I2C Packet Length

Tip: Because I2C has started as the Packet TimeStamp, it does not need to use Unknow_Start_Flag as the start.

4. Bus

Packet #	Name	TimeStamp	Data	Data	Data	Data	Data	Data	Data	Data	Data	Data	Length
1	Bus1(Bus)	-1023	0	1	0	1	0	1	0	1	0	1	10
2	Bus1(Bus)	-1013	0	1	0	1	0	1	0	1	0	1	10
3	Bus1(Bus)	-1003	0	1	0	1	0	1	0	1	0	1	10
4	Bus1(Bus)	-993	0	1	0	1	0	1	0	1	0	1	10
5	Bus1(Bus)	-983	0	1	0	1	0	1	0	1	0	1	10
6	Bus1(Bus)	-973	0	1	0	1	0	1	0	1	0	1	10
7	Bus1(Bus)	-963	0	1	0	1	0	1	0	1	0	1	10

Fig4-45 - Bus Packet List

Packet Length and Packet Idle Length

Packet's TimeStamp is the start of Bus Data; the default length is controlled by the setting dialog box. If the input packet length isn't the end of data. The software will prolong the length of Packet to end the data automatically as the figure below.

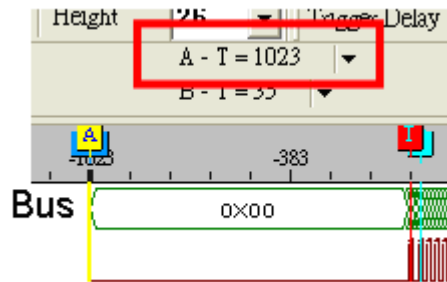

Fig4-46 - Auto-Prolong Packet

The Fig4-46 is a Bus; its first data is 0x00, and its length is 1023. If users input 20 as the Bus length. But 20xaddress is not the end of this data, so the software will prolong the length of the Packet to 1023 automatically.

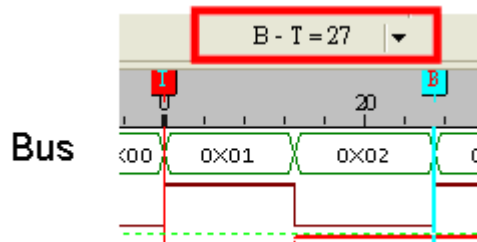

Fig4-47 - Packet End

The Fig4-47 is a Bus. If the Start of the packet is T Bar and the set Bus length is 20, but the data 0x02 isn't the end, at that time, the Packet will be prolonged to the end dot automatically, that is to say, the Address 27 (B Bar) is the End of the packet.

The above two data are made consecutively as the figure below.

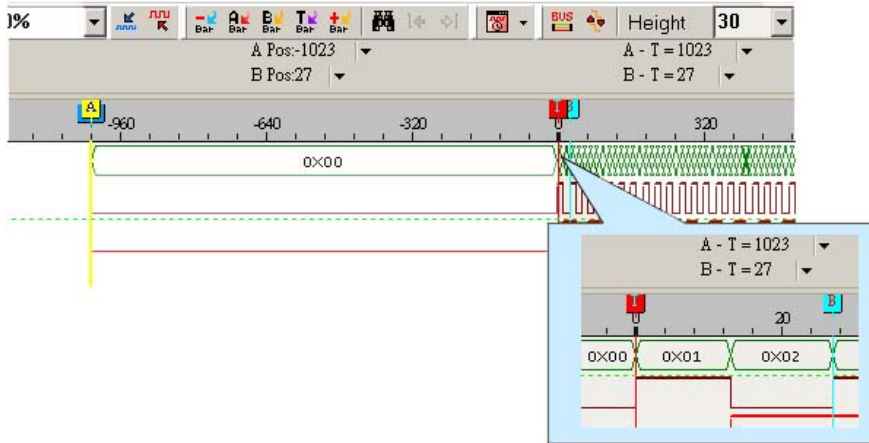

Fig4-48 - Auto-Prolong Packet

The Packet List is displayed as the figure below:

Packet #	Name	TimeStamp	Data	Data	Data	Data	Data	Data	Data	Data	Data	Data	Data	Length
1	Bus1(Bus)	-1023	0	1	0	1	0	1	0	1	0	1	0	10
2	Bus1(Bus)	-1013	0	1	0	1	0	1	0	1	0	1	0	10
3	Bus1(Bus)	-1003	0	1	0	1	0	1	0	1	0	1	0	10
4	Bus1(Bus)	-993	0	1	0	1	0	1	0	1	0	1	0	10
5	Bus1(Bus)	-983	0	1	0	1	0	1	0	1	0	1	0	10
6	Bus1(Bus)	-973	0	1	0	1	0	1	0	1	0	1	0	10
7	Bus1(Bus)	-963	0	1	0	1	0	1	0	1	0	1	0	10

Fig4-49 - Bus Packet List

Tip: The Protocol Analyzer Packet will be explained in the following plug.

5. Packet and Waveform Synchronization

For the convenience of fast corresponding between packet data and waveform data, and what is more, in order to make it easier for users to look up data, we add the Packet and Waveform Synchronization function.

In order to operate conveniently, we add a **Synch Parameter** button on the BUS Packet List as the image below:

Packet #	Name	TimeStamp	Data	Data	Data	Data	Data	Data	Data	Data	Data	Data	Data	Length
1	Bus1(Bus)	-1023	0	1	0	1	0	1	0	1	0	1	0	10
2	Bus1(Bus)	-1013	0	1	0	1	0	1	0	1	0	1	0	10
3	Bus1(Bus)	-1003	0	1	0	1	0	1	0	1	0	1	0	10
4	Bus1(Bus)	-993	0	1	0	1	0	1	0	1	0	1	0	10
5	Bus1(Bus)	-983	0	1	0	1	0	1	0	1	0	1	0	10
6	Bus1(Bus)	-973	0	1	0	1	0	1	0	1	0	1	0	10
7	Bus1(Bus)	-963	0	1	0	1	0	1	0	1	0	1	0	10

Fig 4-50 - Synch Parameter on the BUS Packet List

At the same time, a Synch Parameter Setting dialog box is added.

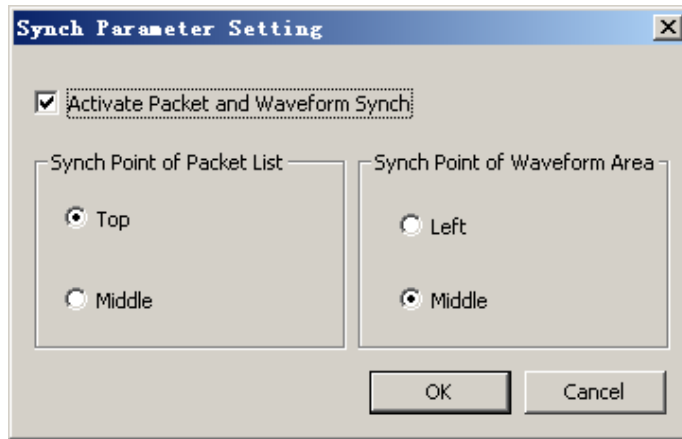

Fig 4-51- Synch Parameter Setting Dialog Box

Activate Packet and Waveform Synch: The default is not activated.

Top: When the Packet and Waveform Synch is activated, the synch point in Packet List is the top packet segment which is displayed by list.

Middle: When the Packet and Waveform Synch is activated, the synch point in Packet List is the middle packet segment which is displayed by list.

Left: When the Packet and Waveform Synch is activated, the synch point in the waveform area is the left packet segment which is displayed by waveform.

Middle: When the Packet and Waveform Synch is activated, the synch point in the waveform area is the middle packet segment which is displayed by waveform.

Activate Packet and Waveform Synch, select **Top** and **Left**.

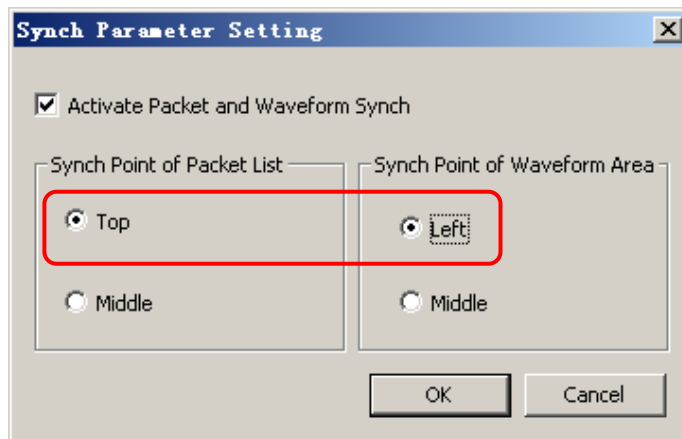

Fig 4-52 - Synch Parameter Setting Dialog Box

Display the corresponding waveform and packet as below image:

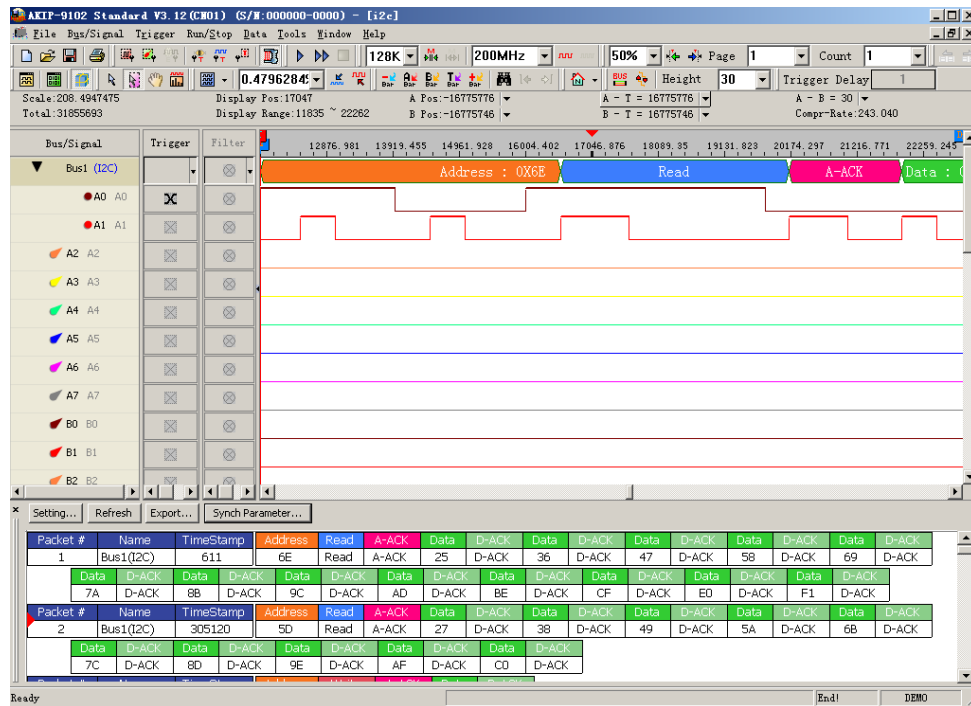

Fig 4-53 - Waveform and Packet Synchronization Interface

4.5 Bus Analysis

The setup is correlated to the Bus which needs to be made up, for example: Bus, Protocol Analyzer.

Open the dialog box:

STEP 1. Click **Tools** on the Menu Bar, and then select **Bus Property** or select  to set up Bus Property.

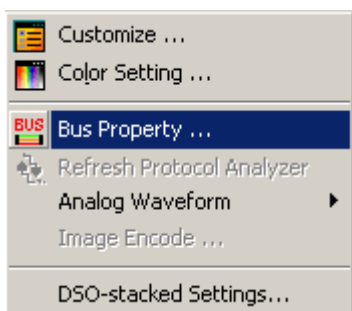

Fig4-54 - Bus Property on Menu Bar



Fig4-55 - Bus Property on Tool Bar

STEP 2. Click the **Right Key** on the Bus/Signal column, and then select **Bus Property**.

Tip: The signals must be grouped into Bus, or the Bus Property can not have effect.

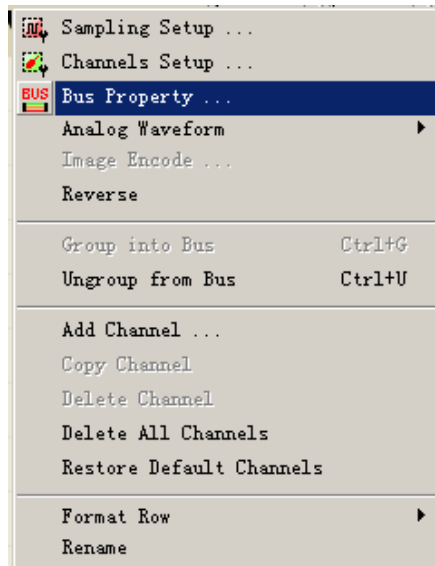

Fig4-56 - Right Key to Set **Bus Property**

4.5.1 Bus Analysis

The Bus Analysis function enables the system to analyze the Bus.

Basic Software Setup for the Bus

STEP 1. Click **Bus Property**, the following dialog box will appear.

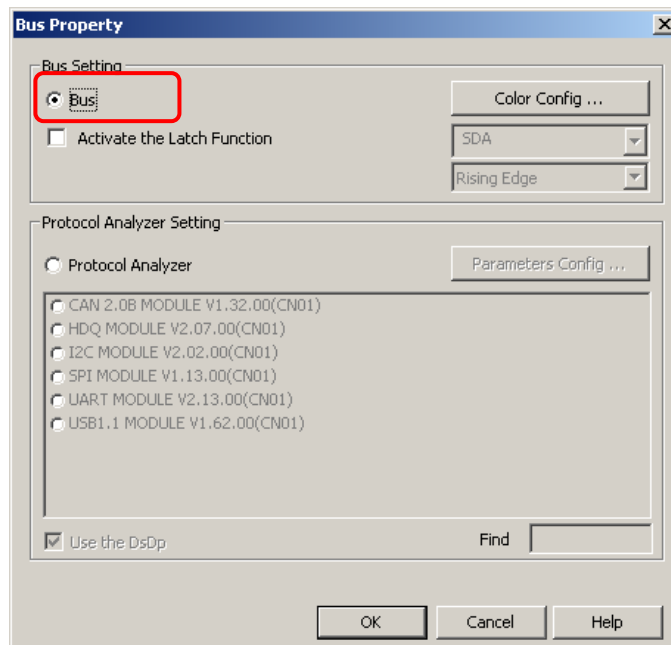

Fig4-57 - Bus Setting

STEP 2. Click Color Configuration to set **Bus Data Color**.

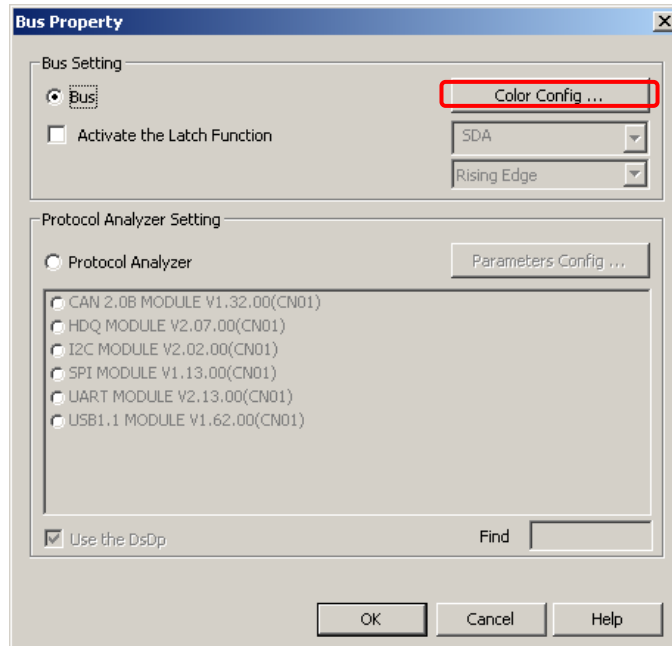

Fig4-58 - Color Configuration

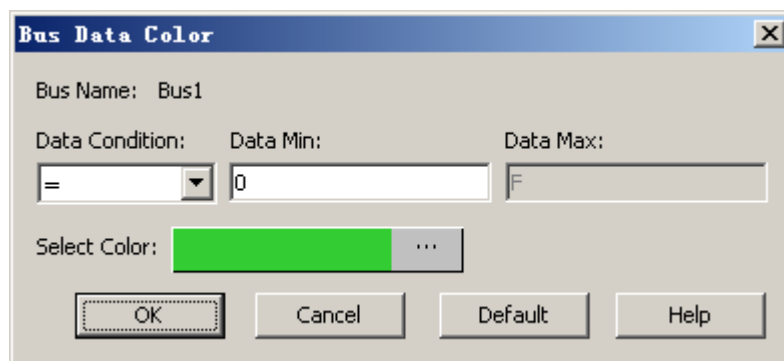

Fig4-59 - Bus Data Color

Bus Name: Display the selected Bus name.

Data Condition: Select the Data Condition to change the Bus data color. There are four options which are = , !=, In Range and Not In Range.

Data Min: Enter the min. data that is required by users.

Data Max: Enter the max. data that is required by users. The max. data can be used only when the set is In Range or Not In Range.

Select Color: Select the changed color according to the Bus condition set by users, the default is Green.

STEP 3. Click **Color Configuration** to open the Bus Data Color dialog box, and set the “Data Condition = 0” and Select Color is Orange.

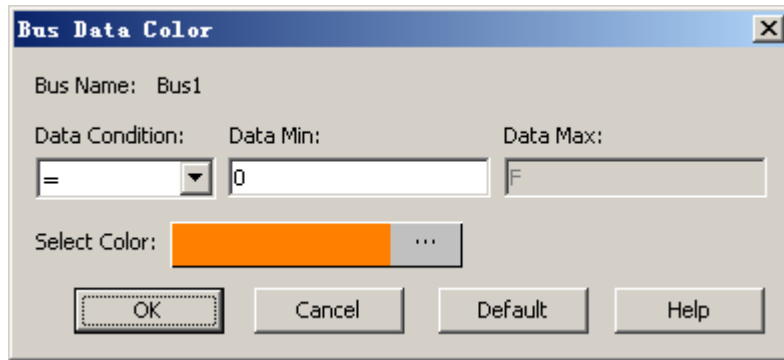

Fig4-60 - Set the Color for Bus1

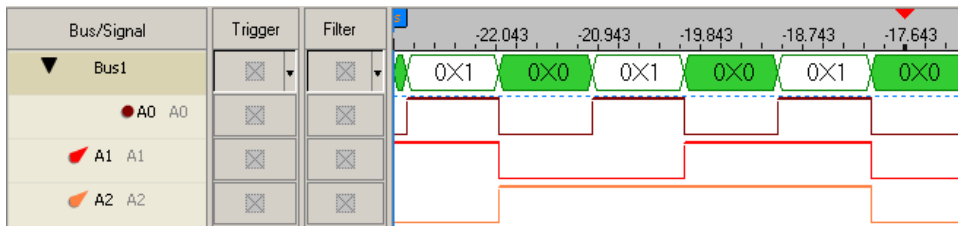

Fig4-61 - Before the Bus Data Color Setting

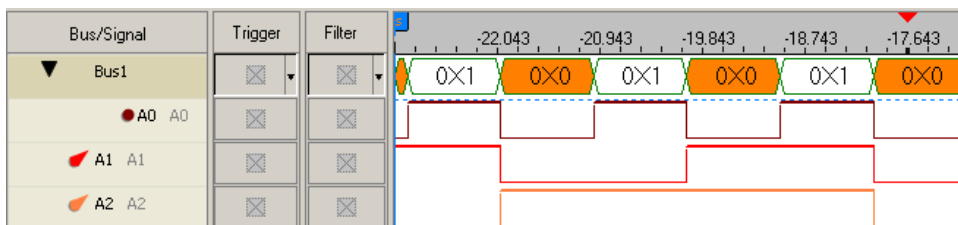

Fig4-62- After the Bus Data Color Setting

Tip: Reserve the original state by the above steps.

STEP4. Activate the Latch Function

Activate the Latch Function: The default is not activated. When the Latch function is activated, the default channel is A0, and there are three conditions for selecting, Rising Edge, Falling Edge and Either Edge; the default is Rising Edge.

Tip: The Latch function is available for the AKIP-9103 and AKIP-9103/1Module, and it is not available for the AKIP-9101 and AKIP-9102 Modules.

Set the Latch function for one Bus. The setting of the Latch channel is A1; the analysis function adopts Rising Edge.

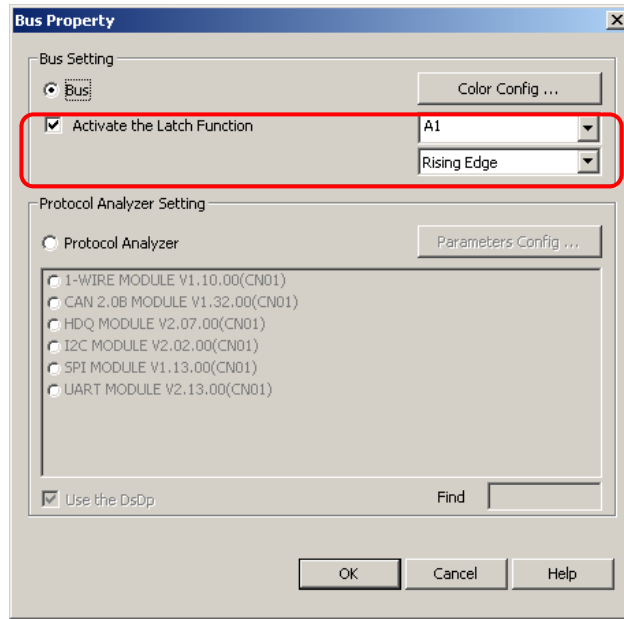

Fig4-63 - Activate the Latch Function

The picture of the waveform analysis:

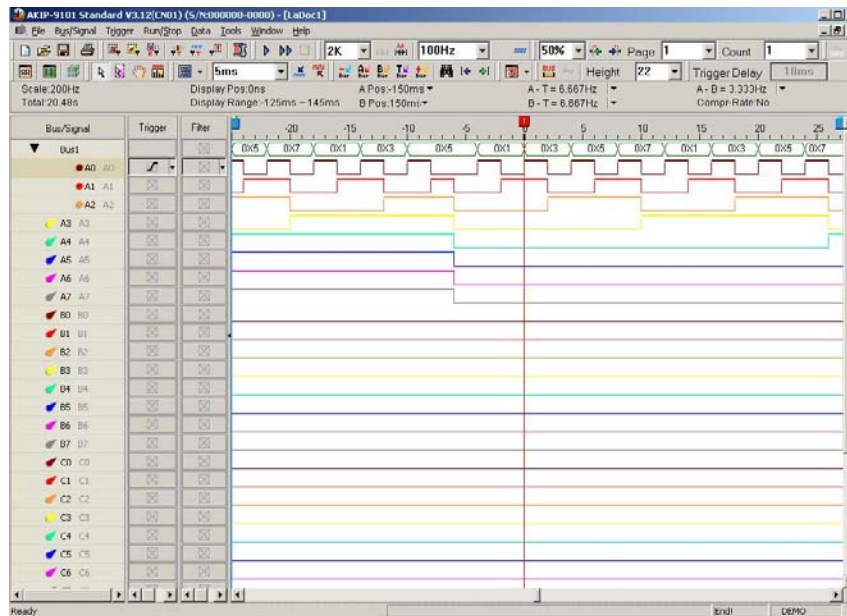

Fig4-64 - The Latch Function Displayed on the Waveform Area

Illustration: The selected channel is A0; the analysis mode is Rising Edge; it indicates that the data of the A1 is read at the Rising Edge. See the T Bar in the above figure, the data of Bus1 is 0X3.

4.5.2 I2C Analysis

I2C Introduction

The I2C, which stands for Inter-Integrated Circuits, is a serial synchronous half-duplex communication protocol. The I2C was first proposed by Philips Semiconductor Netherlands. This I2C protocol consists of a very simple physical interface which has only two signal channels, SDA (Serial Data) and SCL (Serial Clock). Most I2C devices consist of an independently sealed I2C chip, and this I2C chip has direct connection to both SDA and SCL. The data transmission is a byte-base (8-bit base) for every segment. Since many oscilloscopes do not allow engineers to observe timing sequence information directly from the screens of oscilloscopes, this Logic Analyzer was created to help engineers resolve timing sequence issues during their circuit development.

I2C has a multi-control Bus as its physical and firmware interfaces. This protocol analyzer is basically a signal network that may connect to one or several control units. The intention of inventing this protocol was in the application of designing television sets, which allowed the central processing unit to quicken data communications with peripheral chips and devices. The I2C interface is initiated with a SDA triggered **High** and SCL triggered **Falling Edge**. Following the initiation, there will be a set of 7 bits (or 10 bits) address space. Beyond this point, there will be Read/Write, ACK (Acknowledgement), and STOP (or HALT/HLT). The signal information packet is transmitted in bytes. If there are two or more devices trying to access the I2C protocol, whichever device has SCL at logic high will gain access priority.

Furthermore, since I2C is a synchronous communication protocol and data transmission must be in bytes, a complete I2C signal packet must consist of **Start**, **Address**, **Read/Write**, **Data**, **ACK/NACK** and **Stop** segments. They are as following.

Start: This is the initiation of SCL and SDA (1 bit only).

Address: This identifies the device address (7 bits).

Read/Write: This is a data direction bit. 0 = Write, 1 = Read.

ACK/NACK: This is a confirmation bit following every data transmission segment.

Data: The actual signal data transmitted by byte.

Stop: This appears when SCL = High and SDA = Low (1bit only).

4.5.2.1 Software Basic Setup of Protocol Analyzer I2C

Step1. Set up RAM Size, Frequency, Trigger Level and Trigger Position as described in Section 4.1.

Step2. Set up the Falling Edge as the trigger condition on the signal which connects to the tested I2C data pin (SDA).

Step3. Group the analytic channels into Bus1.

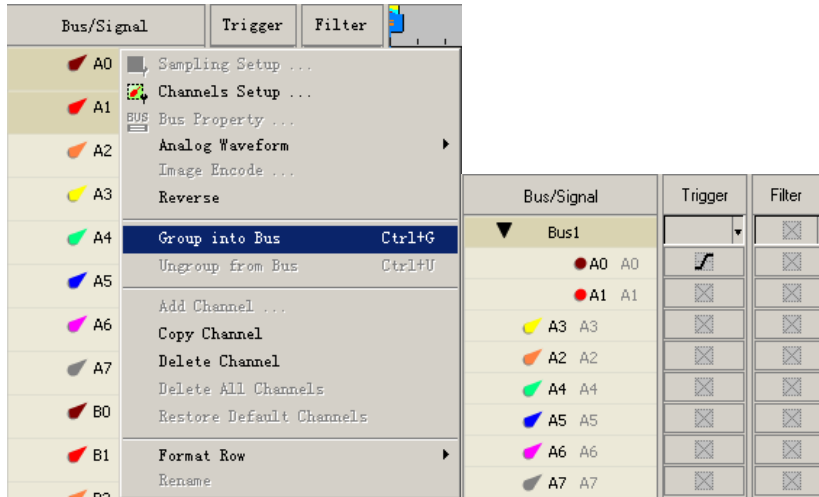



Fig4-65 - Group into Bus

Step4. Select Bus 1, then, press **Right Key** on the mouse to list the menu. Next, click **Bus Property** or click **Tools** and the select Bus Property or click  to open Bus Property dialog box.

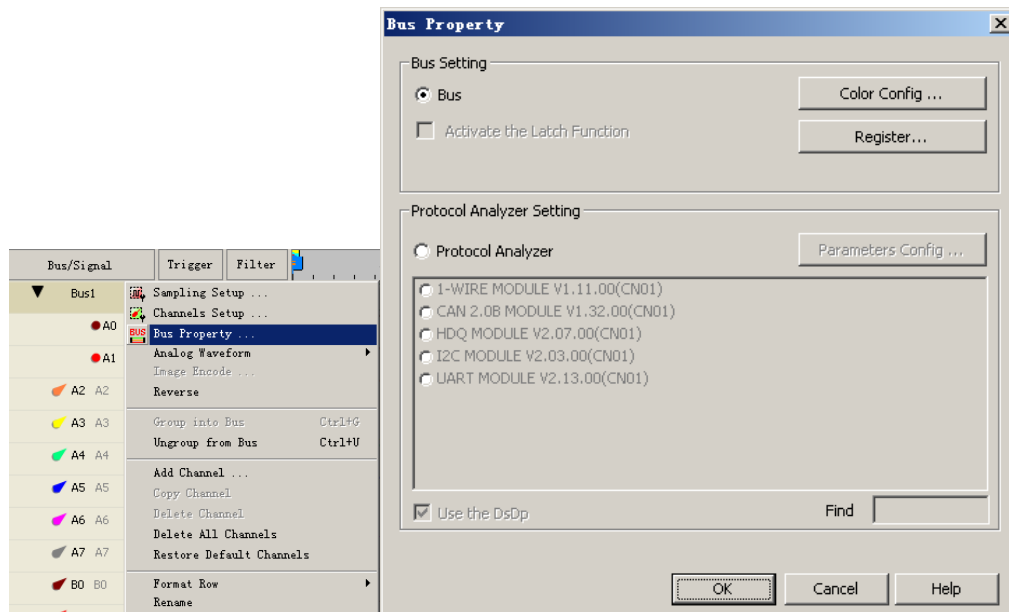

Fig4-66 - Bus Property

Step5. For Protocol Analyzer Setting, select Protocol Analyzer. Then, choose **I2C MODULE V2.03.00 (CN01)**. Next, click **Parameters Configuration**. The following image will appear.

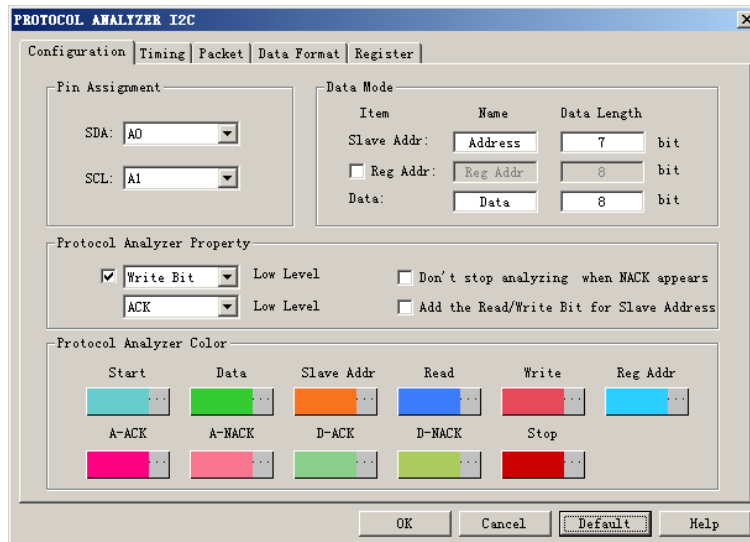

Fig 4-67 – Protocol Analyzer I2C Configuration dialog box

Step6. Set the I2C Configuration dialog box.

Pin Assignment:

SDA Channel: It is the Data channel, and the default is A0.

SCL Channel: It is the Clock channel, and the default is A1.

Data Mode: Set the Data Length used by the Slave Addr, Reg Addr and the Data.

Protocol Analyzer Property:

Set the **Write Bit** or **Read Bit** to Low Level.

Set the **ACK** or **NACK** to Low Level.

Don't stop analyzing when NACK appears: When the option is selected, the data will be analyzed continuously when the NACK appears.

Add the Read/Write Bit for Slave Address: When the option is selected, the decoding will be displayed by way of the added Read/Write Bit for Slave Address.

Protocol Analyzer Color: Users can vary the colors of the decoded packet.

Step7. Press **OK** to exit the dialog box of Protocol Analyzer I2C.

Step8. Click **Run** to acquire I2C signal from the tested I2C circuit. Refer to Fig 4-68.

Tip: Click  icon to view all data, and then select the waveform analysis tools to analyze the waveforms.

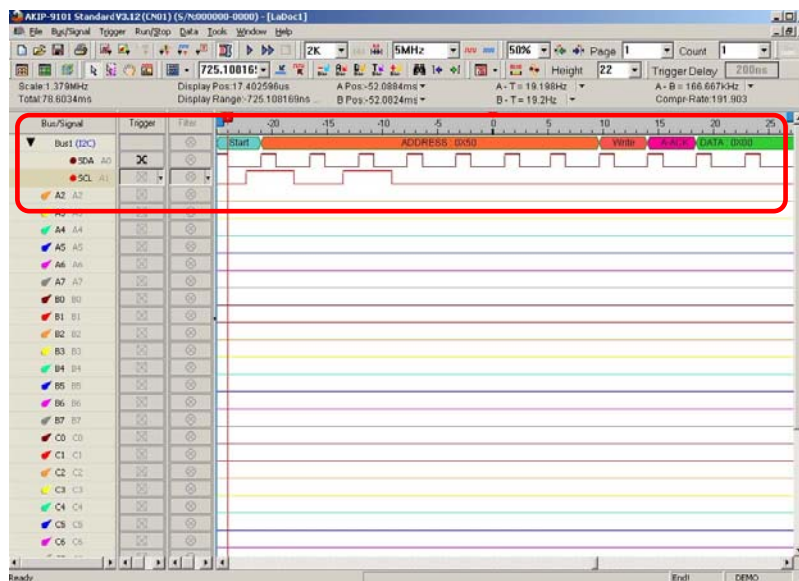

Fig 4-68 – Waveform Analysis

4.5.2.2 Protocol Analyzer I2C Timing Analysis

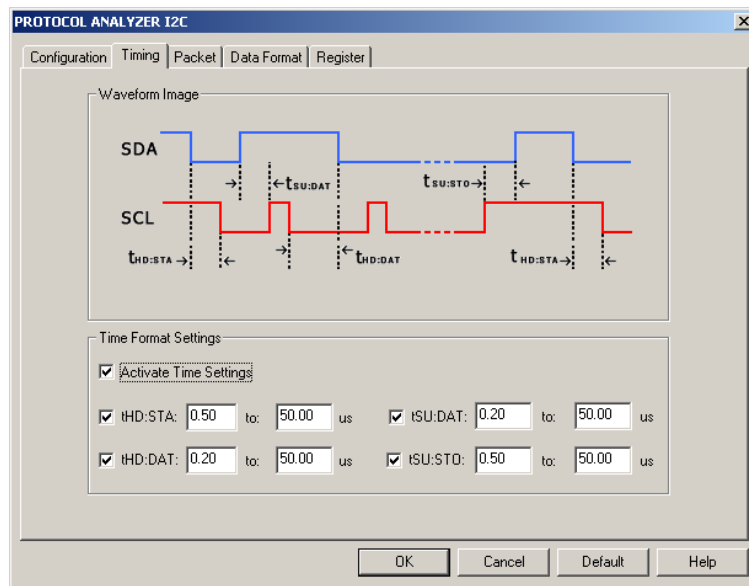

Fig 4-69 – Protocol Analyzer I2C Timing dialog box

Waveform Image: Describe the position of the set time.

Time Format Settings: When the Time Settings is activated, the set time will become the condition of judging decoding. For example, when you want to decode START, you should judge whether the conditions of START are satisfied firstly, and then judge whether the set time of $t_{HD: STA}$ is coincident with the factual waveform. If the two conditions are satisfied, the START can be decoded. Other segments decoding of the packet is the same with that of the START.

4.5.2.3 Protocol Analyzer I2C Packet Analysis

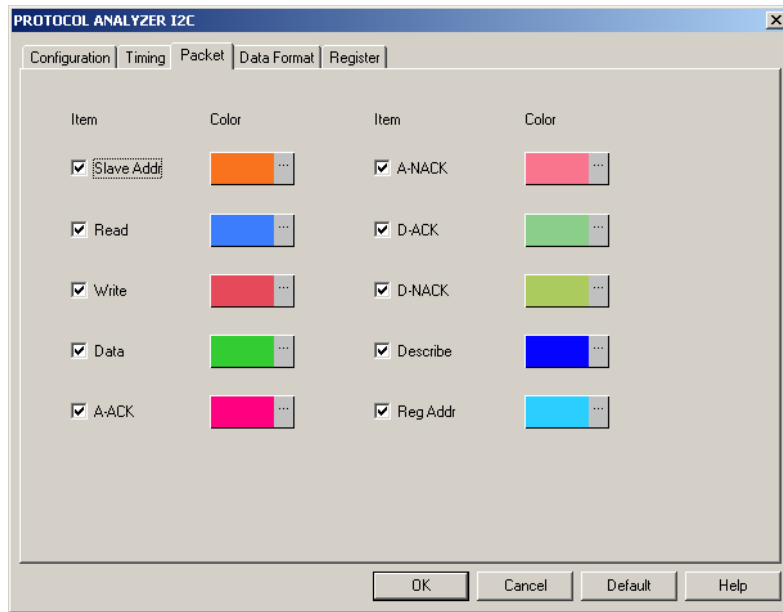

Fig4-70 - Protocol Analyzer I2C Packet dialog box

In the Packet dialog box, users can select the set item to be displayed and the color of item. It is a Bus Packet List view, which includes 4 formats, which I2C happens as follows.

Packet #	Name	TimeStamp	Address	Read	A-ACK	Data	D-ACK	Data	D-ACK	Data	D-ACK	Data
1	Bus1(I2C)	618	6E	Read	A-ACK	25	D-ACK	36	D-ACK	47	D-ACK	58
	D-ACK	Data	D-ACK	Data	D-ACK	Data	D-ACK	Data	D-ACK	Data	D-ACK	Data
	D-ACK	69	D-ACK	7A	D-ACK	8B	D-ACK	9C	D-ACK	AD	D-ACK	BE
	D-ACK	Data	D-ACK	Data	D-ACK	Data	D-ACK	Data	D-ACK	Data	D-ACK	Data
	D-ACK	E0	D-ACK	F1	D-ACK	02	D-ACK	13	D-ACK			
2	Bus1(I2C)	340745	5D	Read	A-ACK	49	D-ACK	5A	D-ACK	6B	D-ACK	7C
	D-ACK	Data	D-ACK	Data	D-ACK	Data	D-ACK	Data	D-ACK	Data	D-ACK	Data
	D-ACK	8D	D-ACK	9E	D-ACK	AF	D-ACK	C0	D-ACK	D1	D-ACK	E2
	D-ACK	Data	D-ACK	Data	D-ACK	Data	D-ACK	Data	D-ACK	Data	D-ACK	Data
3	Bus1(I2C)	590401	18	Write	A-ACK	18	D-ACK	29	D-ACK	3A	D-ACK	
4	Bus1(I2C)	712025	47	Read	A-ACK	70	D-ACK	81	D-ACK	92	D-ACK	A3
	D-ACK	Data	D-ACK	Data	D-ACK	Data	D-ACK	Data	D-ACK	Data	D-ACK	Data
	D-ACK	B4	D-ACK	C5	D-ACK	D6	D-ACK	E7	D-ACK	F8	D-ACK	09
	D-ACK	Data	D-ACK	Data	D-ACK	Data	D-ACK	Data	D-ACK	Data	D-ACK	Data
	D-ACK	2B	D-ACK	3C	D-ACK	4D	D-ACK	5E	D-ACK			

Fig4-71 - Protocol Analyzer I2C Packet List

Packet1: It is commonly normal data, which includes 1 “Address” and 15 “Data”.

Packet2: It is commonly normal data, which includes 1 “Address” and 10 “Data”.

Packet3: It is commonly normal data, which includes 1 “Address” and 3 “Data”.

Packet4: It is commonly normal data, which includes 1 “Address” and 15 “Data”.

Packet Length:

When judging the start of I2C, it is the Packet TimeStamp.

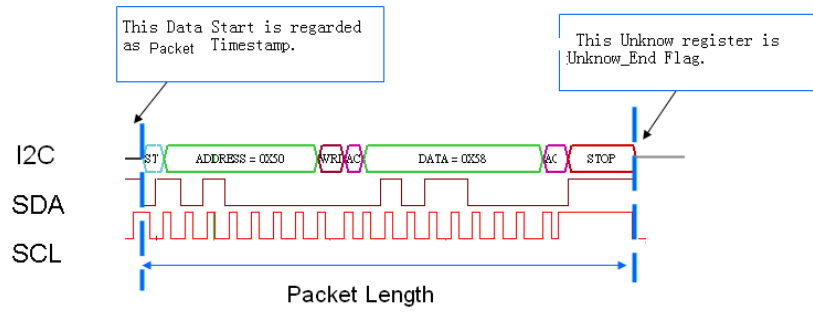

Fig4-72- Packet Length

Packet Length: From START (Start's TimeStamp) to STOP (Unknow_End Flag TimeStamp).

Packet Idling Length: From Unknow_End Flag TimeStamp to Start's TimeStamp.

This Unknow register is Unknow_End Flag.

4.5.2.4 Protocol Analyzer I2C Data Format Analysis

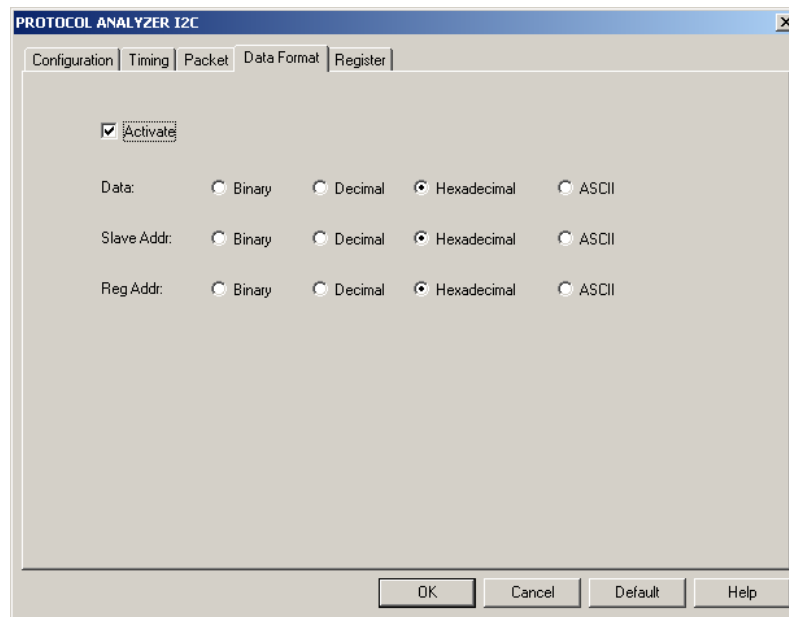

Fig4-73- Protocol Analyzer I2C Data Format dialog box

Users can set the Data Format of the Data, Slave Addr and Reg Addr as their requirements. When selecting the option, Activate, the data formats are decided by the settings in the Protocol Analyzer; when not selecting the option, Activate, the data formats are decided by the settings in the main program.

4.5.3 UART Analysis

UART Introduction

The UART, which stands for Universal Asynchronous Receiver/Transmitter, is a serial asynchronous protocol. The UART is often time-integrated into PC communication devices, and it usually equips an EEPROM (Electronic Erasable/Programmable Read Only Memory) for error checking proposes with other chips. There are two concepts about UART which must be understood before performing any further tasks.

The UART protocol will first translate a parallel data into serial data, for the UART requiring only one wire to transmit signals. The transmission starts at a triggered Low position, and there are 7 or 8 bits of data following afterwards. To halt a transmission, it requires a signal or multiple bits of logic '1'. Odd number bit transmission requires odd parity error checking, and even number bit transmission requires even number error checking. Following the parity check is another data translation from serial data to parallel data. UART also generates an extra signal to indicate receiving and transmitting conditions.

Furthermore, since UART is an asynchronous communication protocol and data transmission may not be in bytes, a complete UART signal Packet must consist of **Start**, **Data**, **Parity**, **Stop**, **Baud Rate** and **TXD** segments. They are as following:

Start: When TXD is changing from **HIGH** to **LOW** voltage (1 bit).

Data: Users must decide the size of signal Packet segment from 4 to 8bits.

Parity: This performs three types of parity checks: odd parity, even parity, and none parity.

Stop: This occurs when TXD is at high voltage. This is adjustable; this is commonly set to 1 or 2.

Baud Rate: This is the data transmission speed according to the initial condition of START.

TXD: This is the transmission direction. It is MSB → LSB by default.

4.5.3.1 Software Basic Setup of Protocol Analyzer UART

- Step1.** Set up RAM Size, Frequency, Trigger Level and Trigger Position as described in Section 4.1. (Tip: The Setup of the Frequency should be higher, but not too far away from the Baud Rate of the test board).
- Step2.** Set up Either Edge as the trigger condition on the signals which are connected to the Tx pin or the Rx pin of the tested UART board.
- Step3.** Set up the Protocol Analyzer UART dialog box. The Protocol Analyzer UART dialog box is set as the steps of I2C.

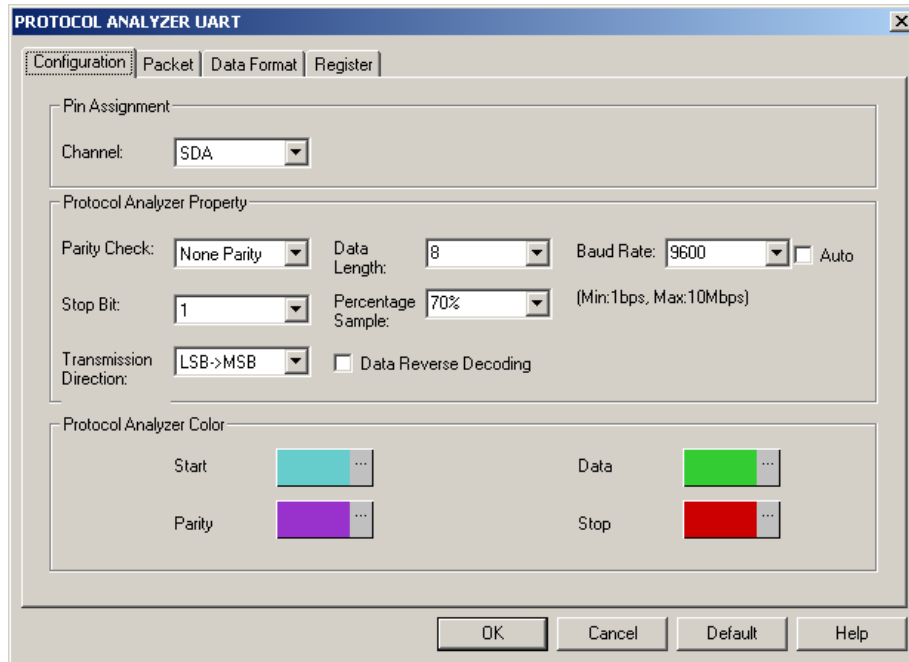

Fig 4-74 – Protocol Analyzer UART Configuration dialog box

- Step4.** Set the **UART Configuration** dialog box

Pin Assignment:

UART only needs one channel to decode the signals, the default is A0.

Protocol Analyzer Property:

Parity Check: There are three options on the dropdown menu: None Parity, Odd Parity and Even Parity, and the default is None Parity.

Data Length: Set the Data Length in the range from 1 to 56.

Stop Bit: Select the Stop Bit from the three options: 1, 1.5 and 2, and it is stopped in the High Level.

Percentage Sample: Users can select the Percentage from the options (50%, 60%, 70%, 80% and 90%) on the dropdown menu, and the default is 70%.

Transmission Direction: Set the Transmission Direction to MSB->LSB or LSB->MSB.

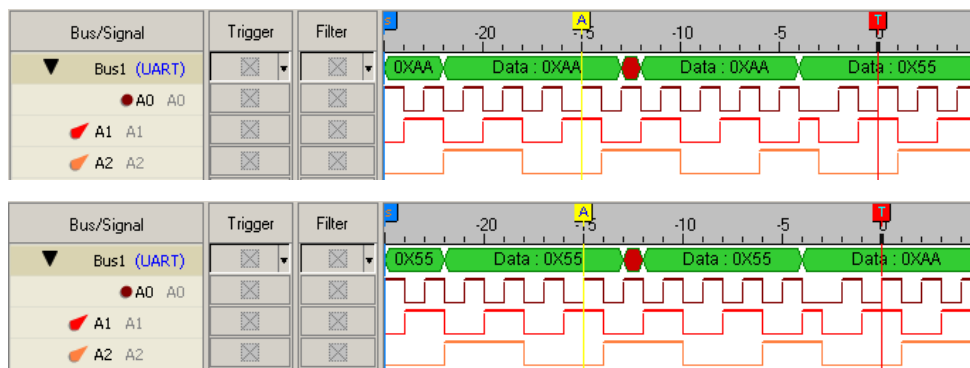
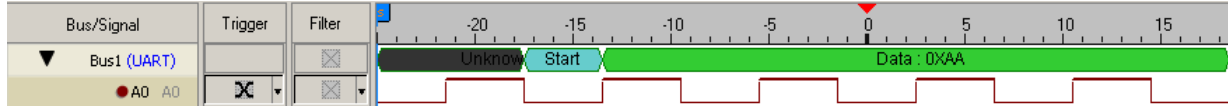

Fig 4-75 – Data Waveforms MSB->LSB and LSB->MSB

Baud Rate: The dropdown menu has options as below: 110, 300, 600, 1200, 2400, 4800, 9600, 19200,

38400, 57600, 115200, 230400, 460800 and 921600. Users can select the desired value from the menu. At the same time, The **Auto** can be selected to calculate the Baud Rate automatically (If the Auto is selected, the Baud Rate will be calculated and displayed on the Configuration dialog box automatically.).

Data Reverse Decoding: When the option is selected, the data will be decoded in reverse.



Without using the reverse data level to decode

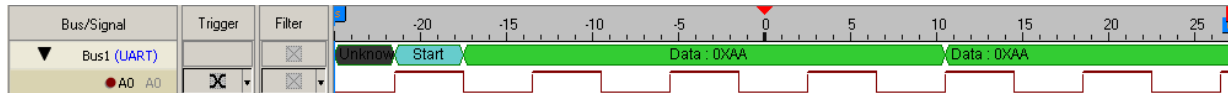

Using the reverse data level to decode

Fig 4-76 – Without/With the Reverse Data Level for Decoding

Protocol Analyzer Color:

Users can vary the colors of the decoded packet.

Step5. Press **OK** to exit the dialog box of Protocol Analyzer UART.

Step6. Click **Run** to acquire the UART signal from the tested UART circuit. Refer to Fig 4-77.

Tip: Click  icon to view all data, and then select the waveform analysis tools to analyze the waveforms.

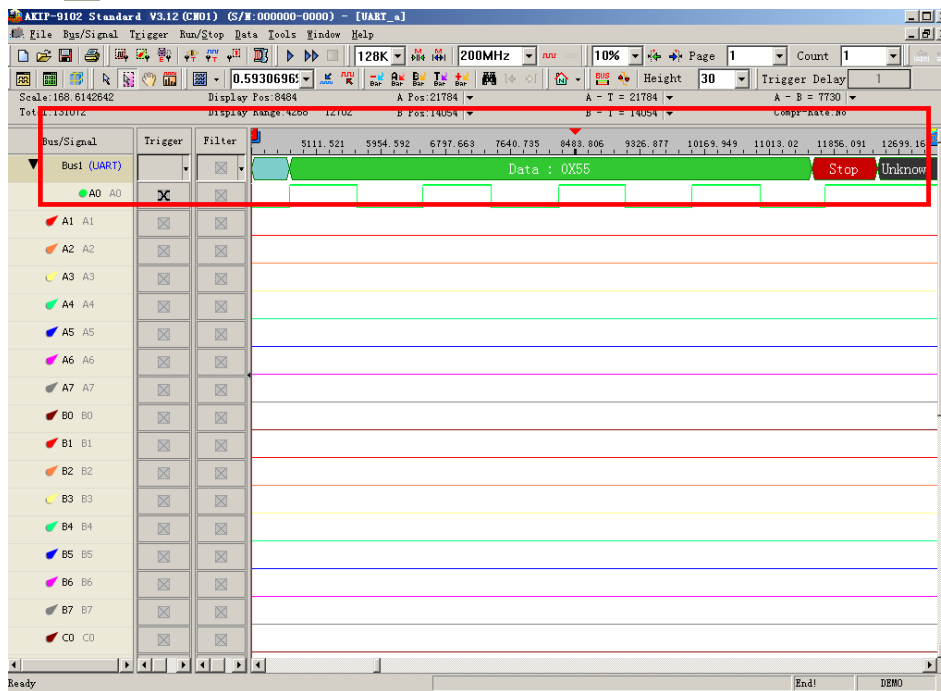

Fig 4-77 – Waveform Analysis

4.5.3.2 Protocol Analyzer UART Packet Analysis

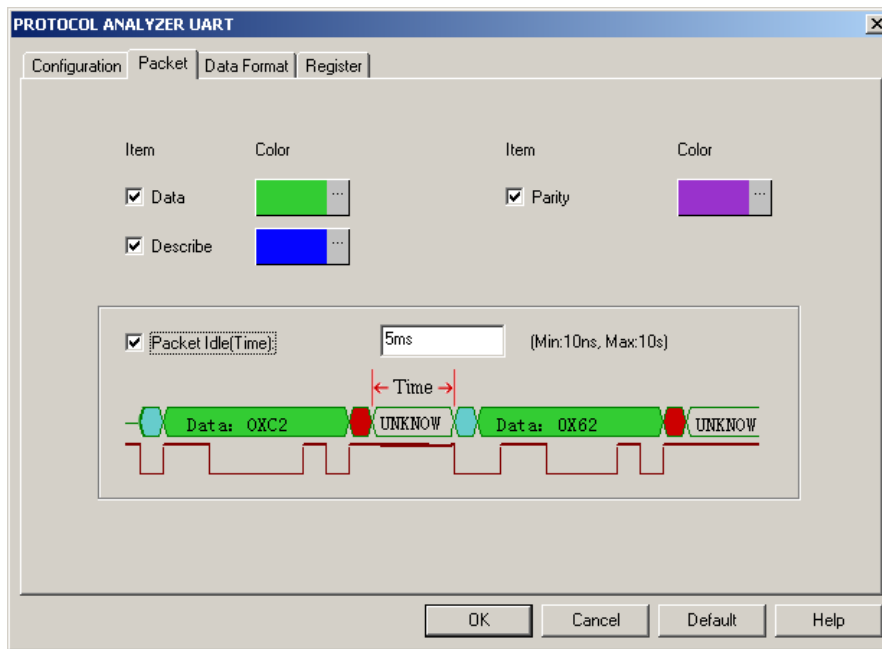

Fig4-78 - Protocol Analyzer UART Packet dialog box

Data: List Data field captured by Bus in the packet display.

Parity: Display parity check in packet.

Describe: Error description to any field (format or data bit).

Packet Idle (Time): When the check box is selected, the default value is 5ms. Specifically, when the Packet Idle (Time) is activated, the packet will be divided again according to the Packet Idle (Time). If the Time Length between the previous packet and the next packet is more than 5ms, the two packets will still be divided, or the two packets will be merged into one packet.

It is a Bus Packet List view, which includes 4 formats, which UART happens below. PARITY clues whether users start PARITY or not.

Packet #	Name	TimeStamp	Data	Parity	
1	Bus1(UART)	20613	1F	Even Parity	
2	Bus1(UART)	133789	2F	Even Parity	
3	Bus1(UART)	246965	0F	Error-0	DESCRIBE Parity Error, should Low
4	Bus1(UART)	360141	37	Even Parity	
5	Bus1(UART)	473317	17	Error-0	DESCRIBE Parity Error, should Low

Fig4-79 - UART Packet List

Packet1: It is commonly normal Data, which includes 1 "Data" and 1 "Parity"; its parity is Even Parity.

Packet2: It is commonly normal Data, which includes 1 "Data" and 1 "Parity"; its parity is Even Parity.

Packet3: It is the state of Parity Error; the DESCRIBE is "Parity Error, should Low".

Note: Because the Even Parity and the Odd are impossible to present to the same Bus, so we only take the Even Parity for an example here.

Packet4: It is commonly normal Data, which includes 1 "Data" and 1 "Parity"; its parity is Even Parity.

Packet5: It is the state of Parity Error; the DESCRIBE is "Parity Error, should Low".

Packet Length: When judging to the start of UART, it is the packet TimeStamp.

State 1: Having Stop:

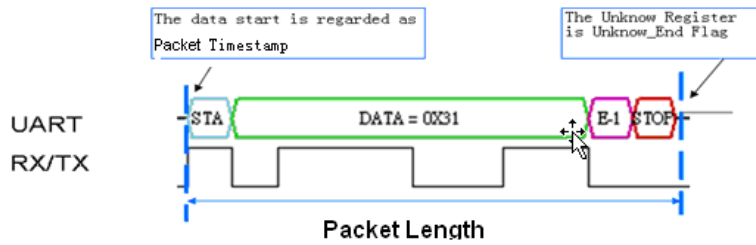

Fig4-80 - Packet Length

State 2: No Stop:

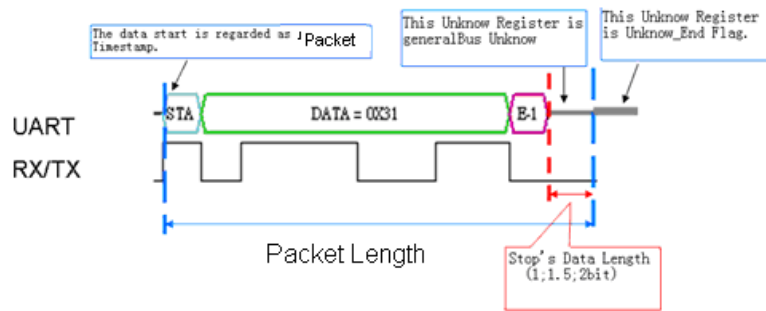

Fig4-81 - Packet Length

If the STOP falls short of condition, it isn't noted down in UART.

Packet Length: From START (Start's TimeStamp) to STOP (Unknow_End Flag TimeStamp).

Packet Idling Length: From Unknow_End Flag TimeStamp to START TimeStamp.

4.5.4 SPI Analysis

SPI Introduction

SPI (Synchronous Peripheral Interface) is a parallel synchronous full duplex protocol with a Bus-like physical interface. This protocol was first developed by Motorola and was generally used for EEPROM, ADC, FRAM, and display device drivers which are equipped with low data transmission speed. The SPI data transmission is synchronous in both receiving and transmitting directions. Although Motorola initially did not define the clocking impulse, it is commonly seen that the clocking impulse is according to the master processor. In practice, there are two clocking impulses: CPOL (Clock Polarity) and CPHA (Clock Phase). The configuration of both CPOL and CPHA decides the sampling rate. When the SPI must transmit serial data, it initiates the highest bit.

Since SPI is a synchronous communication protocol and data transmission may not be in bytes, a complete SPI signal Packet must consist of SCK, MOSI, MISO and SS segments with CPHA and CPOL. They are as following.

SCK: Serial Clock Line (SCL).

MOSI: Master data output, Slave data input (MOSI stands for Master-Out-Slave-In).

MISO: Master data input, Slave data output (MISO stands for Master-In-Slave-Out).

SS: SS stands for Signal Selector of the master device which is to select signals for the Slave devices.

CPHA: The clock phase (CPHA) control bit selects one of the two fundamentally different transfer formats.

CPOL: The clock polarity is specified by the CPOL control bit, which selects an active high or active low clock.

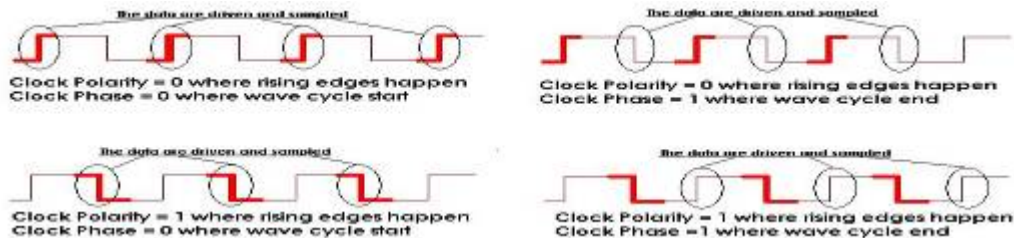

Fig 4-82 – Clock Polarity and Clock Phases

4.5.4.1 Software Basic Setup of Protocol Analyzer SPI

- Step1.** Set up RAM Size, Frequency, Trigger Level and Trigger Position as described in Section 4.1.
- Step2.** Set up the Falling Edge on the signal of SS which connected to the Signal Selector (SS) pin of the SPI tested board.
- Step3.** Set up the Protocol Analyzer SPI dialog box, the Protocol Analyzer SPI dialog box is set as the steps of I2C.

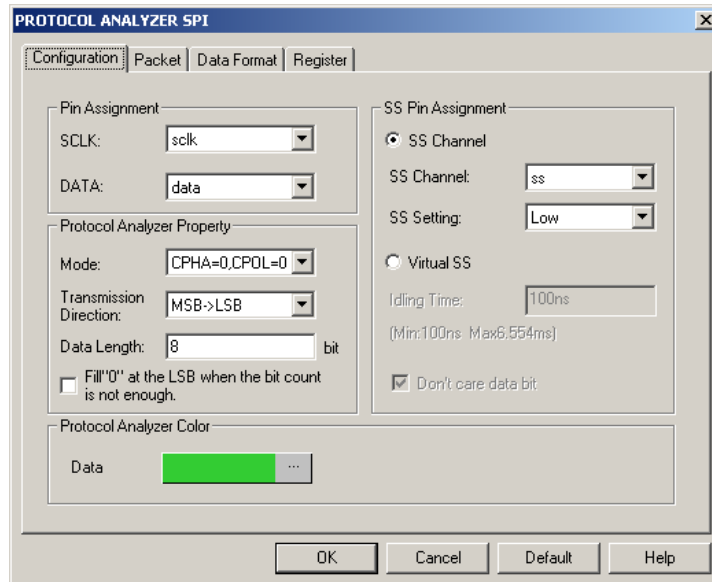

Fig 4-83 – Protocol Analyzer SPI Configuration dialog box

- Step4.** Set the **SPI Configuration** dialog box

Pin Assignment:

SCLK: It is the Clock channel, and the default is A0.

DATA: It is the Data channel, and the default is A2.

Protocol Analyzer Property:

Mode:

There are six modes for selecting, which are CPHA=0,CPOL=0; CPHA=1,CPOL=1; CPHA=1, CPOL=0; CPHA=0, CPOL=1; Rising and Falling.

Transmission Direction:

Set the Transmission Direction to MSB->LSB or LSB->MSB.

Data Length:

Set the Data Length in the range from 1 to 56, and the default is 8.

Fill “0” at the LSB when the bit count is not enough: For example, the value of Data is “1001111”, there is only 7 Bits. When the value of Data is set to 8 Bits, the displayed value should be 10011110.

SS Pin Assignment:

SS Channel: Select the channel for the SS, the default is A1.

SS Setting: Set the Judgment Level of the SS Channel to Low or High.

Virtual SS: When the SS Channel is not activated, the Virtual SS will be activated. The Idling Time of the Virtual SS should be set as an auxiliary condition to decode.

Type the idling time of the SCLK signal on the tested SPI circuit. The idling time is defined as the idling time as shown in Fig 4-84.

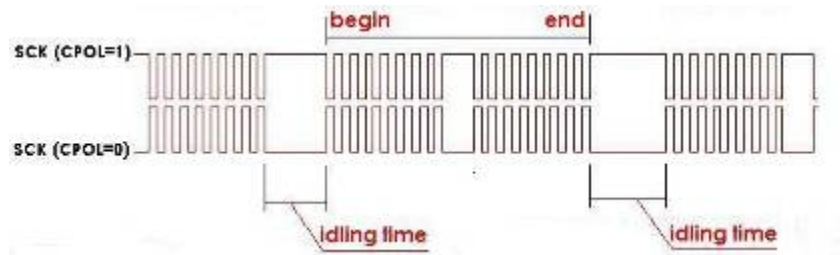



Fig 4-84 – Idling Time

Protocol Analyzer Color: Users can vary the colors of the decoded packet.

Step5. Click **OK** to exit the dialog box of Protocol Analyzer SPI.

Step6. Click **Run** to acquire the SPI signal from the tested SPI circuit. Refer to the Fig 4-85.

Tip: Click  icon to view all the data, and then select the waveform analysis tools to analyze the waveforms.

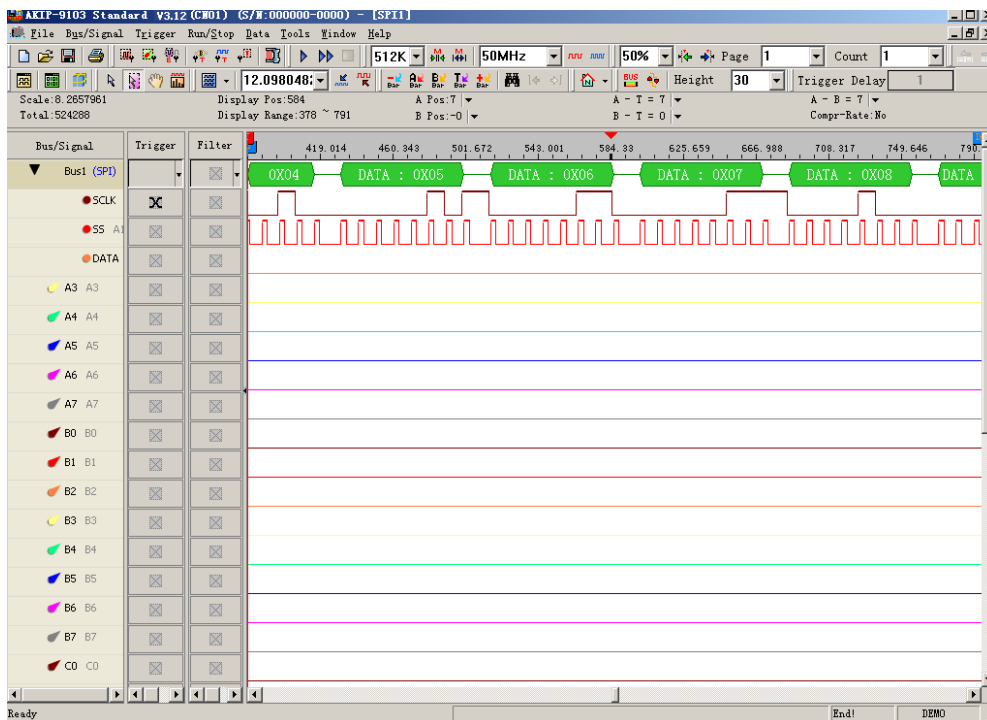

Fig 4-85 – SPI Signal

4.5.4.2 Protocol Analyzer SPI Packet Analysis

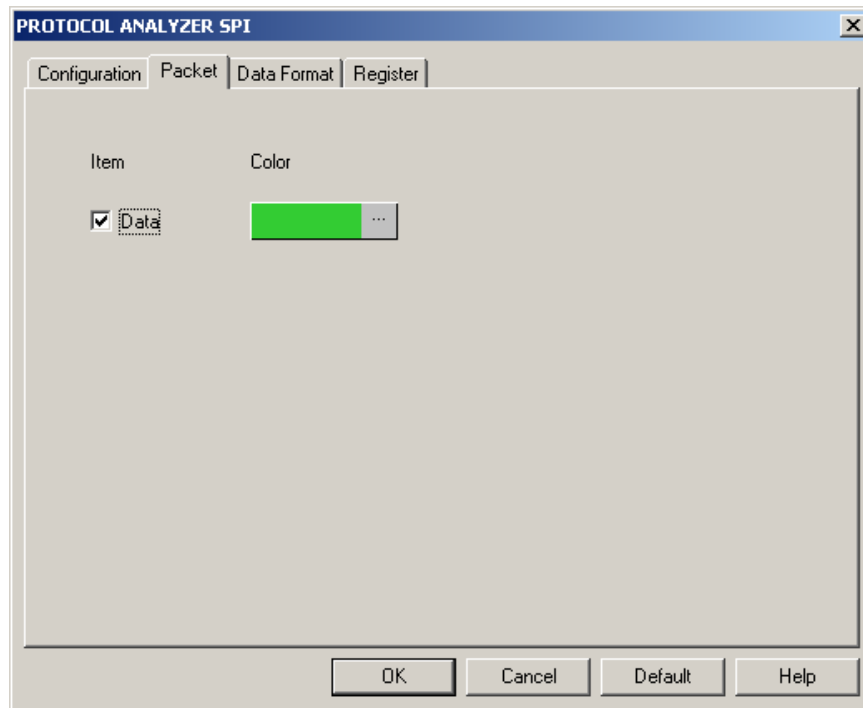

Fig4-86 - Protocol Analyzer SPI Packet dialog box

DATA: List Data field captured by Bus in the packet display.

BUS Packet List:

Packet #	Name	TimeStamp	Data	Data	Data	Data	Data	Data	Data	Data	Data
1	Bus1(SPI)	57	12	23	34	45	56	67	78	89	9A
2	Bus1(SPI)	415	12	23	34	45	56	67	78	89	9A
3	Bus1(SPI)	774	12	23	34	44	AC	CE			

Fig4-87 - Protocol Analyzer SPI Packet List

Packet Length and Packet Idling Length

1. SS channel is activated

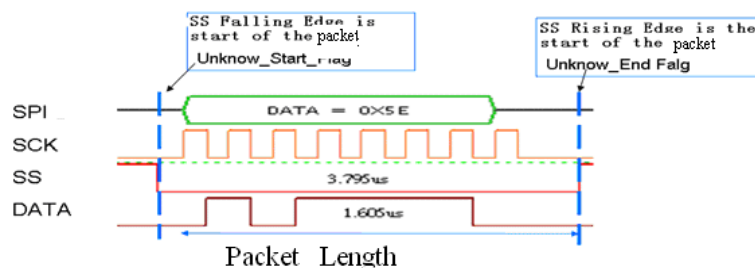

Fig4-88 - Packet Length

Packet Length: From Unknow_Start_Flag TimeStamp to Unknow_End Flag TimeStamp.

Packet Idling Length: From Unknow_End Flag TimeStamp to Unknow_Start_Flag TimeStamp.

2. SS channel is not activated.

Virtual SS is activated 1: Data needs 8-bit; the Idling Time is set as 3us.

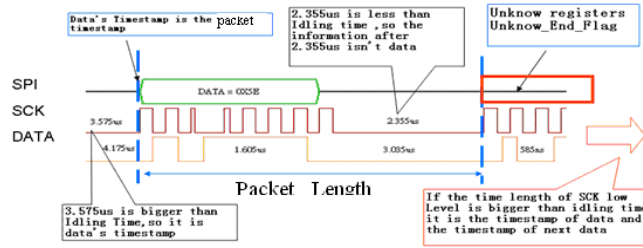

Fig4-89 - Packet Length

Packet Length: From Unknow_Start_Flag TimeStamp to Unknow_End Flag TimeStamp.

Packet Idling Length: From Unknow_End Flag TimeStamp to Unknow_Start_Flag TimeStamp.

Virtual SS is activated 2: Data needs 8-bit; the Idling Time is set as 3us. **Don't care data bit** is not activated.

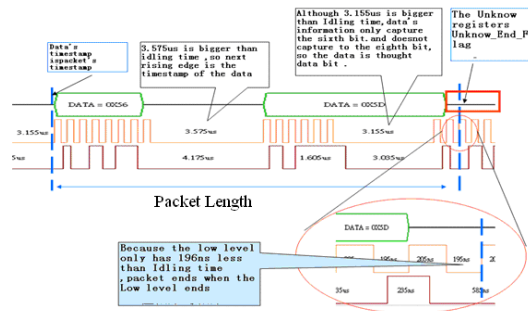

Fig4-90 - Packet Length

Packet Length: From Unknow_Start_Flag TimeStamp to Unknow_End Flag TimeStamp.

Packet Idling Length: From Unknow_End Flag TimeStamp to Unknow_Start_Flag TimeStamp.

Virtual SS is activated 3: Data needs 8-bit; the Idling Time is set as 3us. **Don't care data bit** is activated.

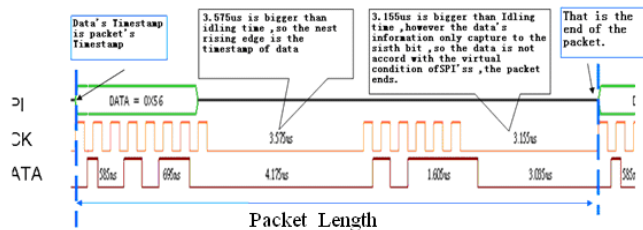

Fig4-91 - Packet Length

Packet Length: From Packet's TimeStamp Data to next Packet's TimeStamp Data.

Packet Idling Length : It is 0.

The End dot is Unknown.

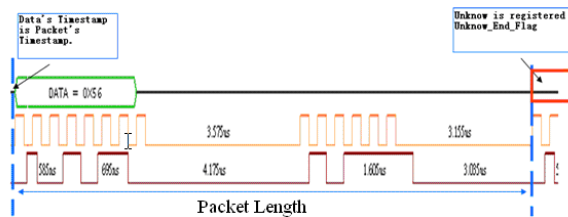

Fig4-92 - Packet Length

Packet Length: From Packet's TimeStamp Data to next Packet's TimeStamp Data.

Packet Idling Length: It is 0.

4.5.5 1-WIRE Analysis

Preface

To increase the Protocol Analyzer feature in order to analyze the Protocol Analyzer 1-WIRE transmission protocol data. Using LA analysis function, the required serial data can be converted and presented in the form of Bus. Therefore, the software needs to add a dialog box so as to set up a Protocol Analyzer 1-WIRE dialog box.

1-WIRE Introduction

1. Brief Introduction

Features

1-WIRE is a non-synchronous half-duplex serial transmission, which requires only one OWIO to transmit data. The typical 1-WIRE transmission structure is illustrated in Figure 4-95. During the 1-WIRE transmission, the OWIO can be used to transmit data and supply power to all devices connected to the 1-WIRE. OWIO will link to a 4.7K Ohm Pull-High electric resistance which is linked to the power supply (3V-5.5V). The transmission speed for 1-WIRE can be divided into two types, standard and high speed. Every 1-WIRE has a unique 64-bit code for the device to recognize. Therefore, the maximum number of link devices is 1.8; almost unlimited.

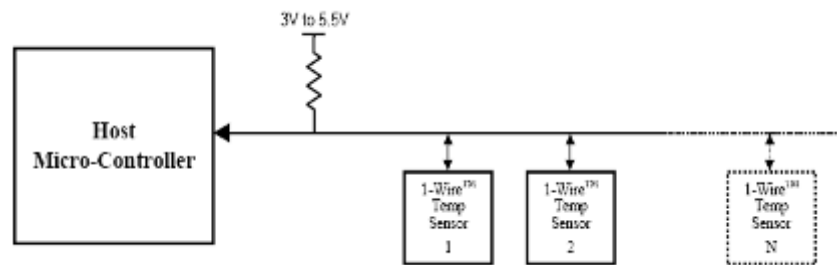

Fig4-93 - Applications

Applications

1-WIRE is commonly applied to the EEPROM and to certain sensor interfaces.

2. Protocol Analyzer Signal Specifications

Parameter	Value
Name of Protocol Analyzer	1-WIRE
Required No. of Channels	1
Signal Frequency	Not fixed, around 10K
Appropriate Sampling Rate	1MHz
Same Data Time Per Bit	<input type="checkbox"/> Yes <input checked="" type="checkbox"/> No
Name of Syn. Signals	OWIO
Data Verification Point	30 us after the falling edge signals

3. Protocol Analyzer IO Description

Name	Function
OWIO	The only I/O transmits Reset signals and data.

4. Protocol Analyzer Electrical Specifications

Parameter	Min.	Typ.	Max.	Unit	Note
High-count Voltage	2.8		5.2	V	Every IC varies according to the Pull-High voltage.
Low-count Voltage		0		V	

Protocol Analyzer 1-WIRE Format Description

Two speed types of 1-WIRE: Standard: 1MHz (1us) High: 5MHz (0.2us)

Four types of 1-WIRE Signals:

1. Reset:

Every communications period starts with Reset signal. Master will send a Reset Pulse so that all the Slave devices on the 1-WIRE Protocol Analyzer enter into recognition status. When one or many Slaves receive Reset Pulse, a Presence Pulse signal will be sent back from Slave, indicating receipt of the signal.
2. Write 0: Send a "0" bit to Slave (Write 1 time slot).
3. Write 1: Send a "1" bit to Slave (Write 1 time slot).
4. Read Data:

"Read data sequences" resembles "Write time slot." However, when Master releases BUS and reads data from Slave devices, Master creates samples from BUS status. In this way, Master can read any 0 or 1 bit from Slave devices.

Four signal types are described respectively in the following:

1. Reset:
 - (1) When Master starts communicating with Slave, Master first sends a low-count Reset Pulse (TX) of t_{RSTL} (Standard speed: 480us; High Speed: 48us) for a period of time.

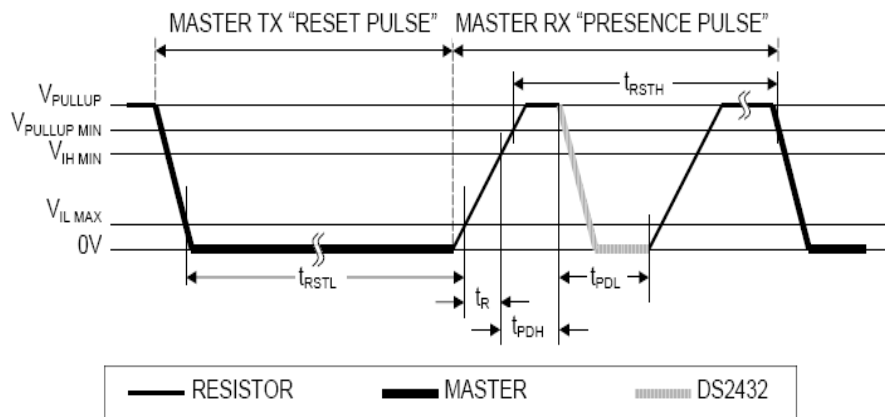

Fig4-94 - Master TX Reset Pulse and Master RX Presence Pulse

- (2) Then, Master releases Protocol Analyzer and enters the RX mode. Through high- pull resistor, 1-WIRE Protocol Analyzer is pulled back to the high status.
- (3) Then, Master detects a rising edge from the Data Line when every slave will wait for a period of time (t_{PDH}) (standard speed: 15-60us; high speed: 2-6us) and send back a Presence Pulse to Master (t_{PDL}) (standard speed: 60-240us; high speed: 8-24us).
- (4) Finally, the 1-WIRE Protocol Analyzer will be pulled back to the high status through the resistor.
- (5) Meanwhile, Master can detect any online Slave.
- (6) From Fig4-95, the low count Reset Pulse and Presence Pulse signals can be clearly seen.

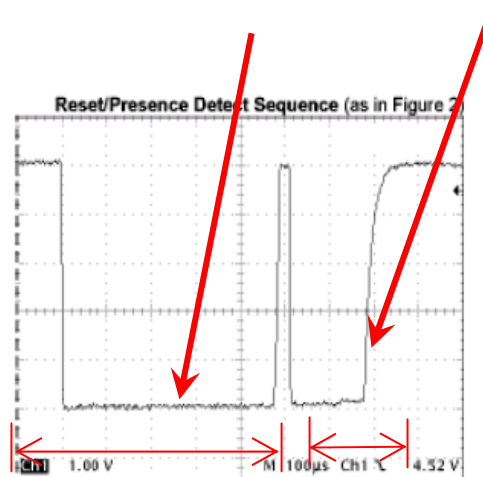

Figure 2a. You can clearly see the negative going reset and the presence pulse

Fig4-95 - Reset/Presence Detect Sequence

2. Write Data:

- (1) To initialize Write Data, Master will convert the Data Line from the high logic to the low.
- (2) There are two types of Write time slot: Write 1 time slot and Write 0 time slot.
- (3) During a write cycle, all Write time slots must have duration of at least 60us and a recovery period of 1us.
- (4) When the I/O line goes down, Slave devices create samples from 15-60 us.
 - A. Write 0: If the sampling is low, 0 is generated as in Fig4-96:

Write-zero Time Slot

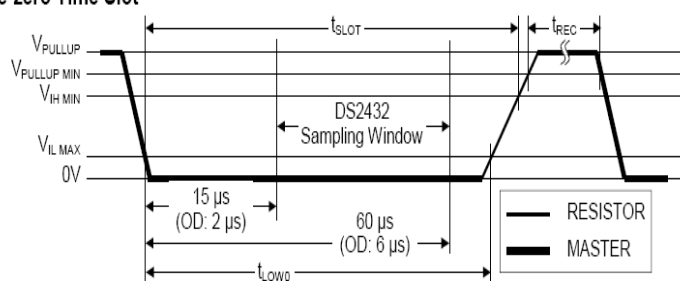

Fig4-96 - Write-zero Time Slot

- B. Write 1: If the sampling is high, 1 is generated (Note: Read 1 is of a similar waveform pattern) as in Fig4-97:

Write-one Time Slot

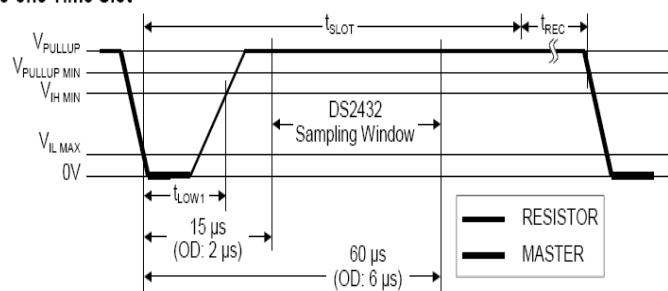

Fig4-97 - Wrote-one Time Slot

3. Read Data:

- (1) When Slave reads data, Master will generate a Read time slot.
- (2) To initialize Read Data, Master has to convert Data line from the high logic to the low.
- (3) Data line must be kept as low as 1us.
- (4) The Output Data of Slave must be 14us at most.
- (5) To read from 15us where Read slot starts, Master must stop driving I/O.

Read-data Time Slot

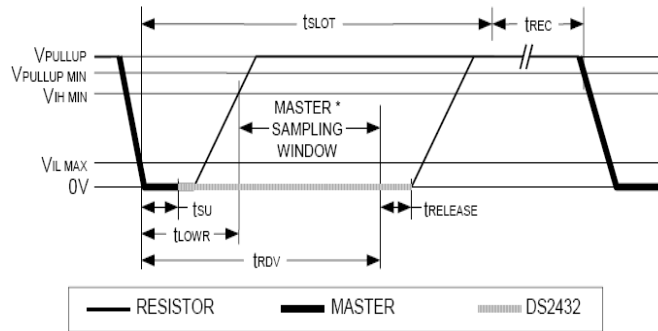

Fig4-98 - Read-data Time Slot

- (6) When Read Time Slot ends, I/O Pin will be pulled back to the high count through the external resistor.
 - (7) During a write cycle, all Write time slots must have duration of at least 60us and a recovery period of 1us.
4. Typical 1-WIRE Conversation model can be summarized as below:

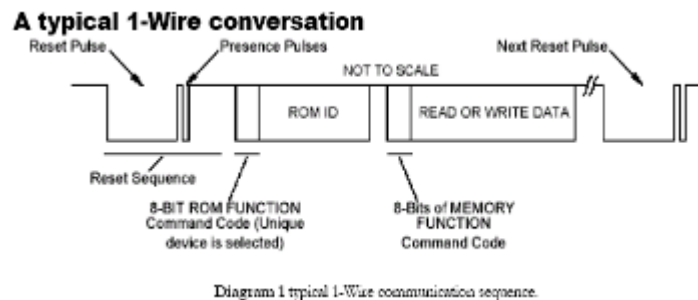
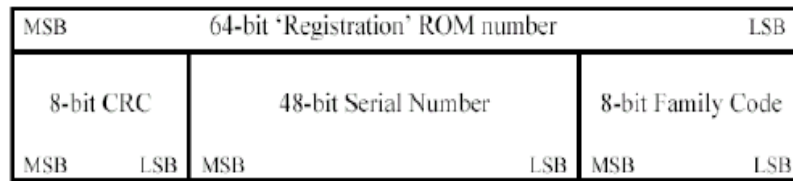

Fig4-99 - A Typical 1-WIRE Conversion

- (1) Master keeps Protocol Analyzer at low signal (standard speed: 480us; high speed: 48us) as the Reset Pulse.
- (2) Then, Master releases Protocol Analyzer and locates a Presence Pulse responded by any online Slave.
- (3) The above two points are Reset Pulse and Presence Pulse, which can be put together as a Reset Sequence.
- (4) If Presence Pulse is detected, the slave location will enable Master to access Slave using the Write 0 or Write 1 Sequence.

5. 1-WIRE Serial Number:

- (1) Every 1-WIRE Slave has a unique laser memory.
- (2) The serial number is 64bits.
- (3) The serial numbers are 8bytes in total, located in three individual, which are illustrated as below:



- (4) Starting from LSB, the first byte is for family code, which is used to identify product categories.
- (5) Next, the 48bits is the only address for storage.
- (6) The last byte, MSB is used to store CRC.

4.5.5.1 Software Basic Setup of Protocol Analyzer 1-WIRE

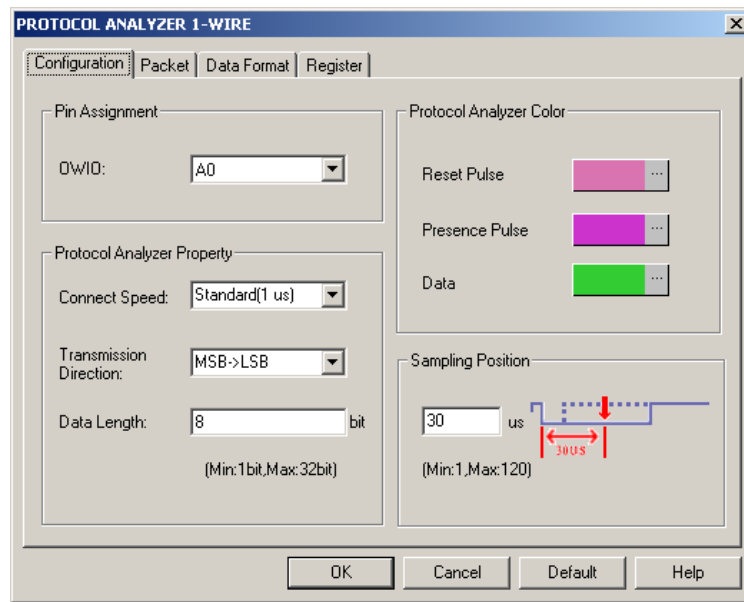

Fig4-100 - Protocol Analyzer 1-WIRE Configuration dialog box

Set the **1-WIRE Configuration** dialog box.

Pin Assignment:

1-WIRE only needs one channel to decode the signals, and the default is A0.

Connect Speed:

The Connect Speed can be set to Standard(1 us) or High(0.2 us).

Transmission Direction:

The Transmission Direction can be set to MSB->LSB or LSB->MSB.

MSB->LSB: From High Level to Low Level.

LSB->MSB: From Low Level to High Level.

Data Length:

The Data Length can be set in the range from 1 to 32-bit, and the default is 8-bit.

Sampling Position:

The Sampling Position can be set in the range from 1 to 120us, and the default is 30us.

Protocol Analyzer Color:

Users can vary the colors of the decoded packet.

User Interface Instructions

Set up the Protocol Analyzer 1-WIRE dialog box which is set as the steps of I2C.

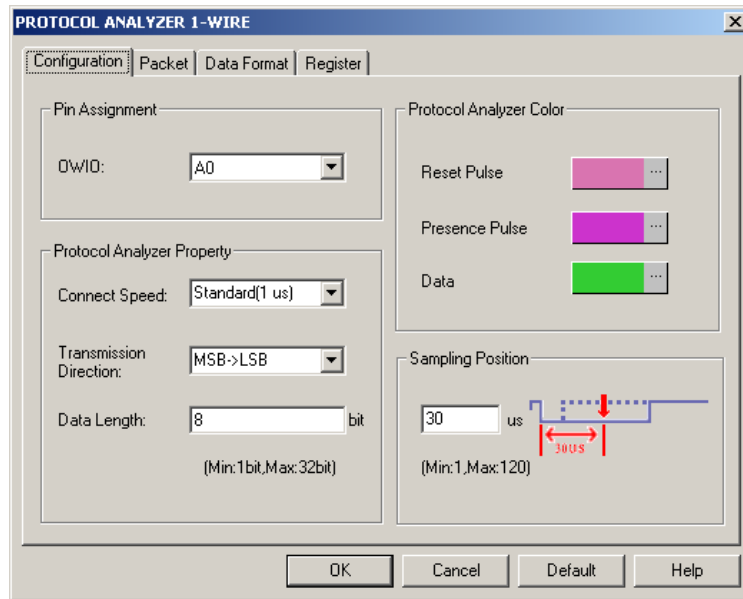

Fig4-101 - Protocol Analyzer 1-WIRE Configuration dialog box

STEP 1. Select Channel

1-WIRE has only one OWIO. Select the channel that it is to link the OWIO.

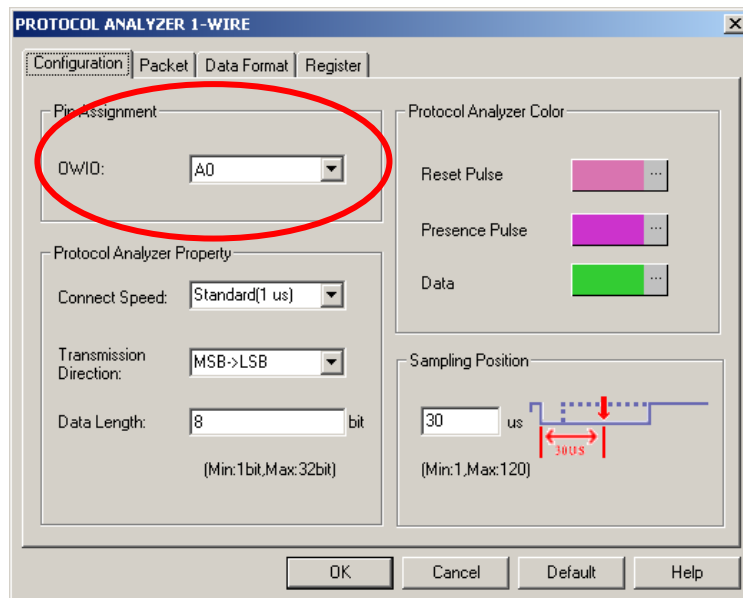

Fig4-102 - Protocol Analyzer 1-WIRE Channel Setup

STEP 2. Set the Connect Speed

1-WIRE has two modes: Standard(1 us) and High(0.2 us). The speed setup according to the specifications of the object to be tested and the default mode is standard.

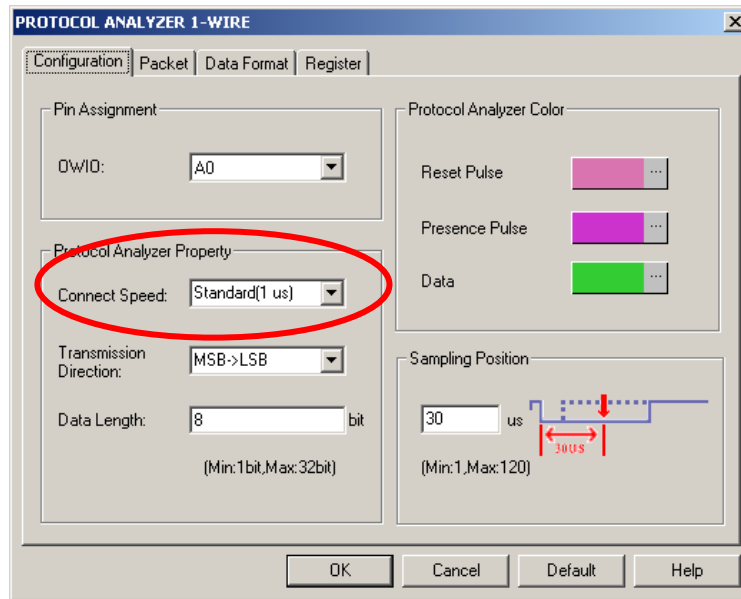

Fig4-103 - Protocol Analyzer 1-WIRE Connect Speed Setup

STEP 3. Set the Transmission Direction

Set the Transmission Direction as either MSB -> LSB or LSB -> MSB.

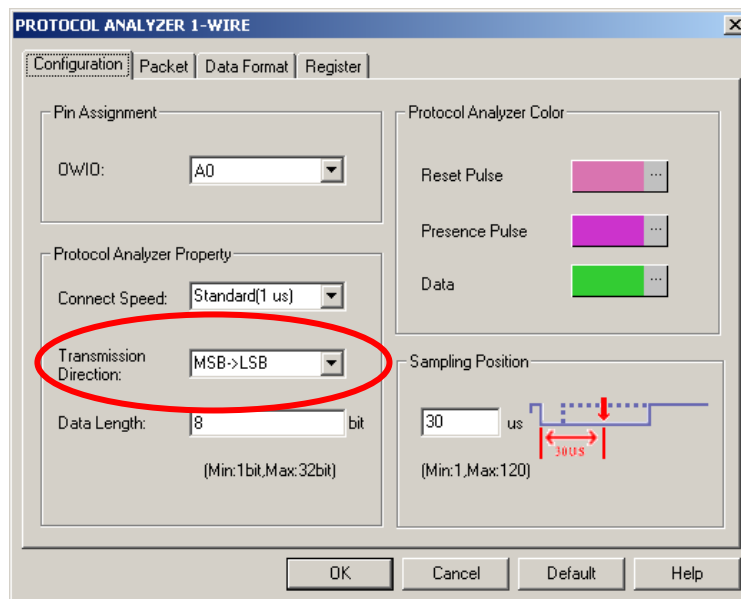

Fig4-104 - Protocol Analyzer 1-WIRE Transmission Direction Setup

STEP 4. Set the Sampling Position

Users can slightly adjust the sampling position of 1-WIRE. This feature is applicable when the signal cannot be

decoded. The default value is 30us.

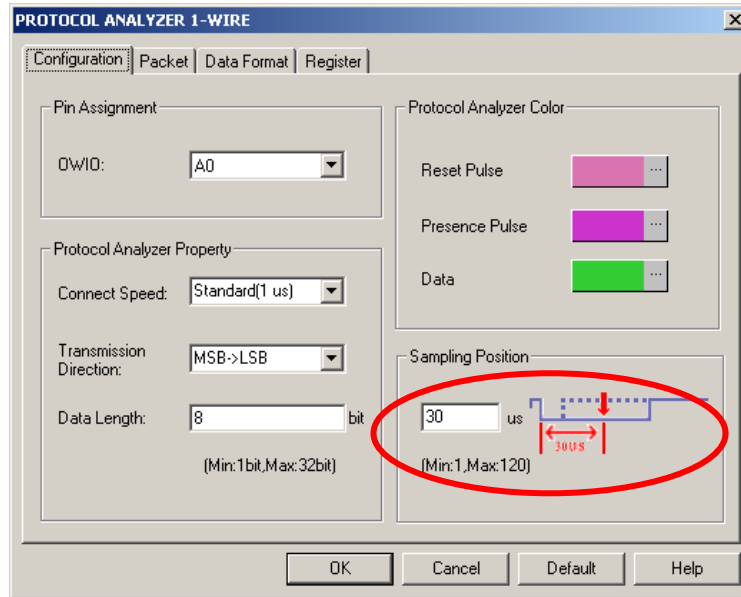

Fig4-105 - Protocol Analyzer 1-WIRE Sampling Position Setup

STEP 5. Set the Data Length

This function decides how many bits of data can be combined as one set of figures. The default is 8 bits, and the maximum is 32bits.

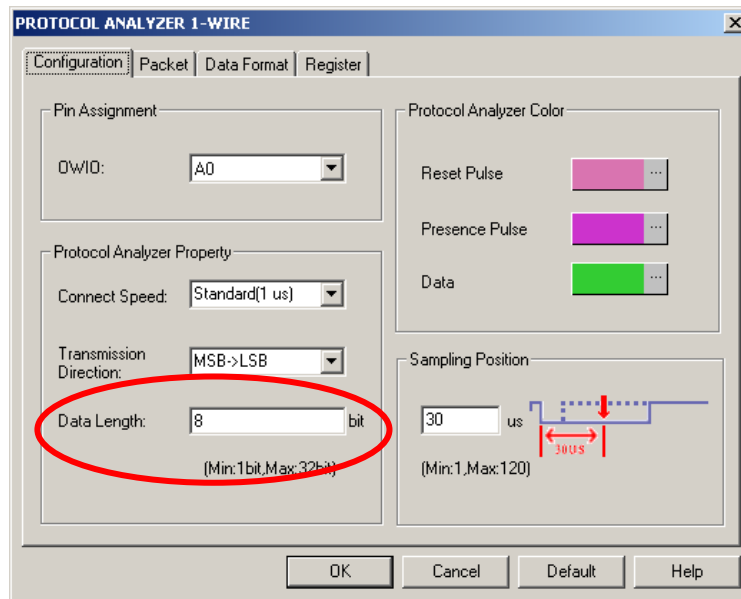

Fig4-106 - Protocol Analyzer 1-WIRE Data Length Setup

4.5.5.2 Protocol Analyzer 1-WIRE Packet Analysis

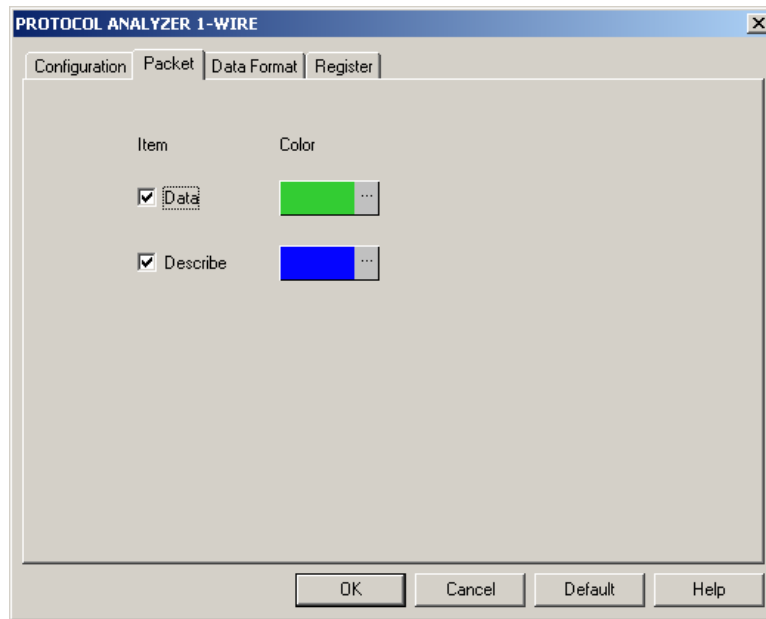

Fig4-107- Protocol Analyzer 1-WIRE Packet dialog box

That is the new View; the below View includes several formats that 1-WIRE can happen; it describes Data number and their positions.

Packet #	Name	TimeStamp	Data
1	Bus1(1-WIRE)	4032363	33 96 30 96 03 90 02 48 B7 FF FF FF FF FF 04 00
2	Bus1(1-WIRE)	8065053	33 96 30 96 07 90 00 48 F7 FF FF FF FF FF 04 00
3	Bus1(1-WIRE)	12096936	33 96 30 96 03 90 02 48 8F FF FF FF FF FF 04 00
4	Bus1(1-WIRE)	16129232	33 96 30 96 03 90 02 48 8F FF FF FF FF FF 04 00
5	Bus1(1-WIRE)	20161527	33 96 30 96 07 90 01 48 2F FF FF FF FF FF 04 00

Fig4-108 - Protocol Analyzer 1-WIRE Packet List

- Packet 1:** It is commonly normal Data, which includes 1 “Data”.
 - Packet 2:** It is commonly normal Data, which includes 1 “Data”.
 - Packet 3:** It is commonly normal Data, which includes 1 “Data”.
 - Packet 4:** It is commonly normal Data, which includes 1 “Data”.
 - Packet 5:** It is commonly normal Data, which includes 1 “Data”.
- Packet and Idling Length: Packet’s TimeStamp is reset.

4.5.6 HDQ Analysis

Preface

Increase the Protocol Analyzer feature to analyze the Protocol Analyzer HDQ transmission protocol data. Using LA analysis function, the required serial data can be converted and presented in the form of Protocol Analyzer. Therefore, the software needs to add a dialog box so as to set up a Protocol Analyzer HDQ dialog box.

HDQ Introduction

1. Brief Introduction

Features

Protocol Analyzer HDQ is a non-synchronic half-duplex serial transmission, which requires only one HDQ and uses a quasi-PWM (Pulse Width Modulation) to verify the serial data.

Applications

HDQ is commonly applied to the display interface for battery management.

2. Protocol Analyzer Signal Specifications

Parameter	Value
Name of Protocol Analyzer	HDQ
Required No. of Channels	1
Signal Frequency	Not fixed, around 12MHz, 13MHz and 19.2MHz
Appropriate Sampling Rate	100MHz
Same Data Time Per Bit	<input type="checkbox"/> Yes <input checked="" type="checkbox"/> No
Name of Syn. Signals	HDQ
Data Verification Point	Low signals > 190us converts to High signals > 40us

3. Protocol Analyzer IO Description

Name	Function
HDQ	The sole I/O transmits Host and BQ-HDQ status and data.

4. Protocol Analyzer Electrical Specifications

Parameter	Min.	Type	Max.	Unit	Note
Logic Input High	2.5			V	
Logic Input Low			0.5	V	

Protocol Analyzer HDQ Format Description

The format changes according to the pulse width, so the display must refer to the defined pulse width. Protocol Analyzer HDQ is made up of 16 bits signals. Firstly, after the period of status signals, a device will be installed for the 7 bits address through the Host so that 1-bit signals can be read or written. After a response time of high signals, data will be exported in 8 bits format with the data and location content from LSB to MSB. The following is the Host to BQ-HDQ analysis.

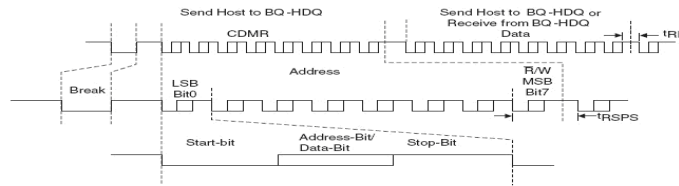

Fig4-109 - Host to BQ-HDQ Analysis

Protocol Analyzer Format

Break

This is the initial bit for the Protocol Analyzer HDQ: after Low signal lasting a period of $t(B)$, it is then converted to a High signal lasting a period of $t(BR)$. The length of Low signal is no less than 190us whereas the High signal is no less than 40us.



Fig4-110 - Pulse from Low to High

Address

The Address comprises 7 bits. The initial Low signal lasts a period of $t(HW1)$ and if the write-0 status continues through the end of the $t(HW0)$ period, the signal will convert to High and last throughout the period of $t(CYCH)$, as shown by the dotted line in the following figure. Conversely, if it is the write-1 status, after $t(HW1)$ period of time, the signal will convert to High and last throughout the period of $t(CYCH)$, which is of 1 bit and no less than 190 us. The $t(HW1)$ range is from 0.5us to 17us and no more than 50us. The $t(HW0)$ range is from 86us to 100us and no more than 145us.

Read/Write

Read/Write is 1 bit. 0 and 1 are displayed in the same way as the above description.

T (RSPS)

The High signal lasts a period of 190us-320us. The following 8-bit data is Send Host to BQ-HDQ or Receive from BQ-HDQ Data.

Data

Made up by 8 bits, and it is Send Host to BQ-HDQ or Receive from BQ-HDQ Data. It operates in the same way as in 2.2 and the data is from LSB to MSB.

BQ-HDQ To Host

If the data transmission is read by BQ-HDQ To Host, the initial Low signal lasts a period of $t(DW1)$ and if the write-0 status continues through to the end of the $t(DW1)$ period, the signal will convert to high and last throughout the period of $t(CYCD)$, as shown by the dotted line in the following figure. Conversely, if it is the write-1 status, after $t(DW1)$ period of time, the signal will rise and last throughout the period of $t(CYCD)$, which is of 1 bit and ranges from 190us to 260us. The $t(DW1)$ ranges from 32us to 50us and no more than 50us. The $t(DW0)$ ranges from 80us to 145us.

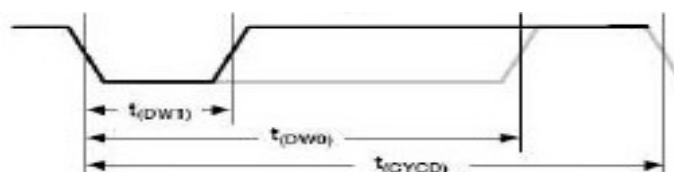

Fig4-111 - Signal from BQ-HDQ to Host

4.5.6.1 Software Basic Setup of Protocol Analyzer HDQ

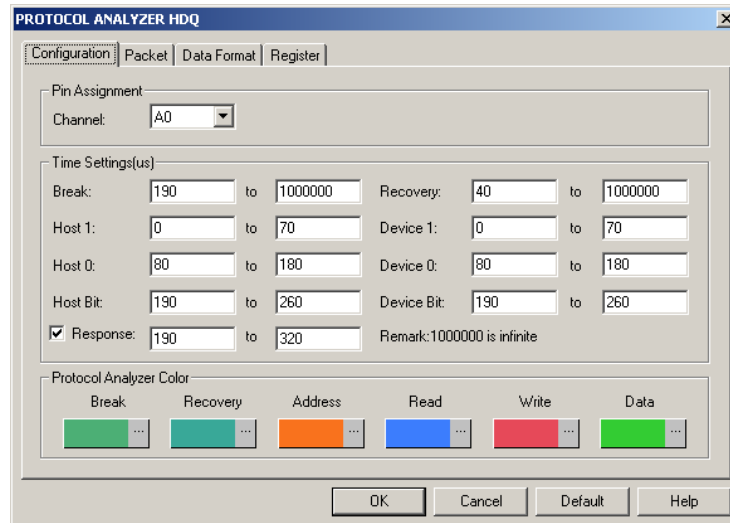

Fig4-112 - Protocol Analyzer HDQ Configuration dialog box

Set the **HDQ Configuration** dialog box.

Pin Assignment:

HDQ has only one signal channel, therefore it only specifies the name of the channel and marks the selected channel.

Protocol Analyzer Name: Display the name of the selected Bus.

Channel: Preset as A0.

Timing Settings(us):

Set the time for Break, Address, Read, Write, Data and Recovery.

Protocol Analyzer Color: Users can vary the colors of the decoded packet.

Operating Instructions

Open the LA operation interface.

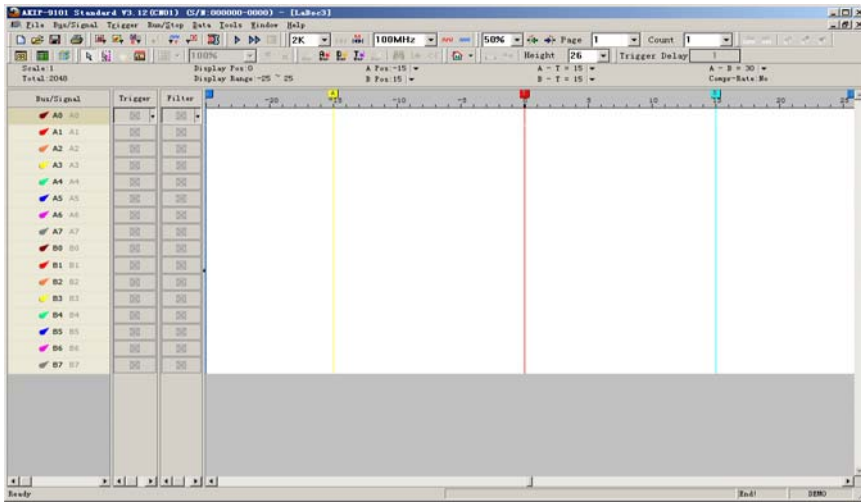

Fig4-113 - Operation Interface

Sample the HDQ signal or open the sampled waveform.

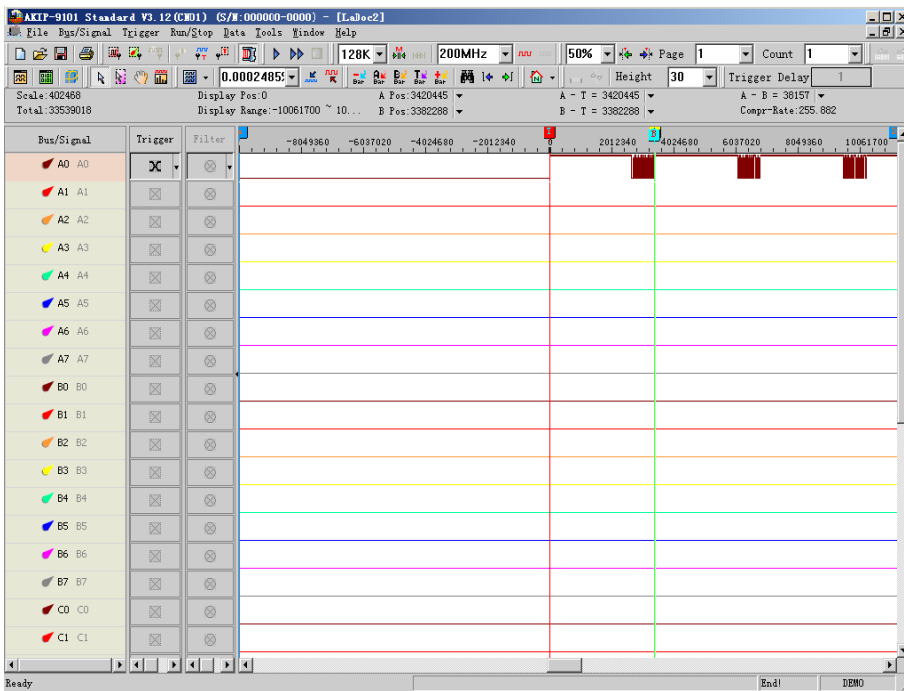

Fig4-114 - HDQ Waveform

Arrange the signal channels into Bus.

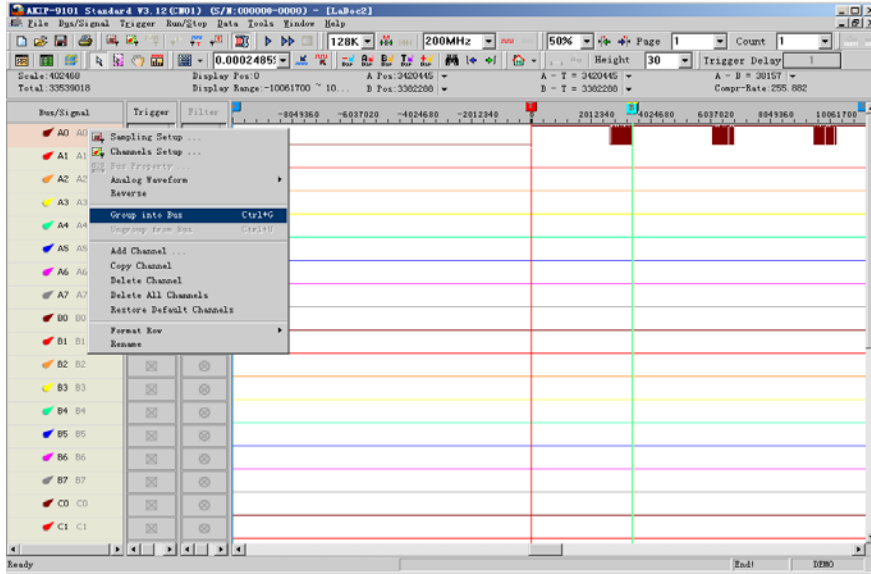

Fig4-115 - Group into Bus

Select Bus Property.

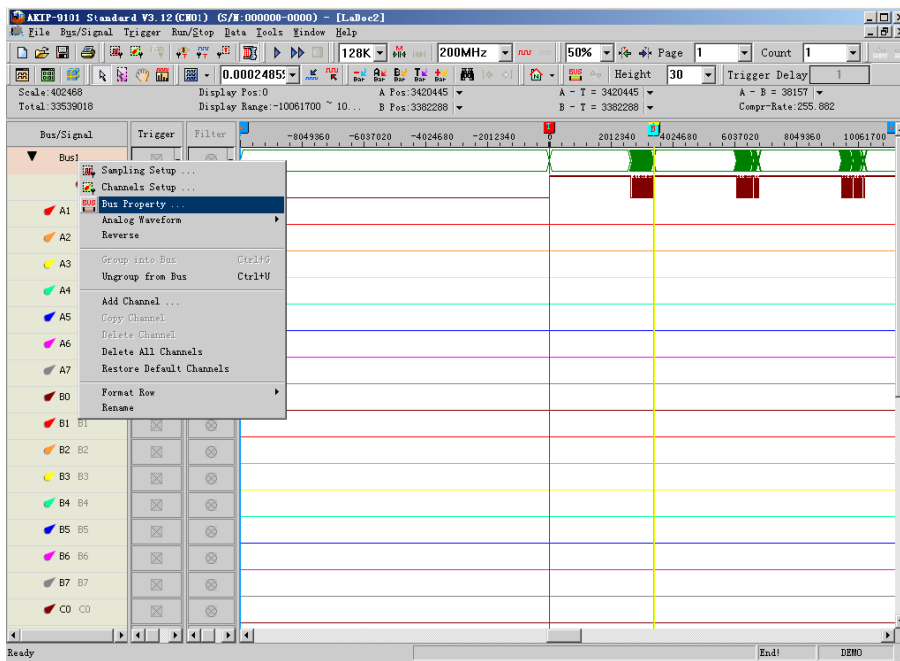

Fig4-116 - Bus Property

Select the decoding function of the Protocol Analyzer HDQ and select **OK** to confirm.

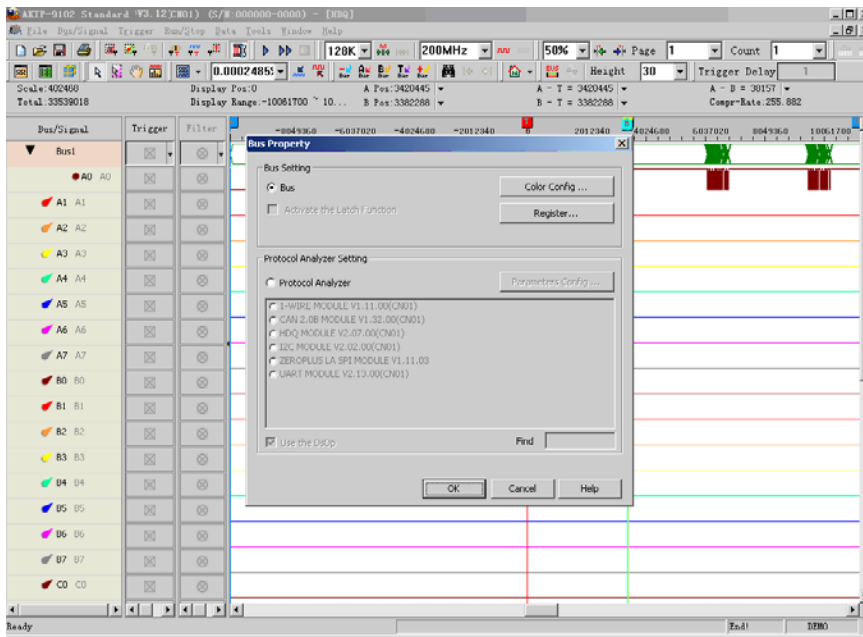

Fig4-117 - Protocol Analyzer HDQ

Complete the Protocol Analyzer HDQ decoding.

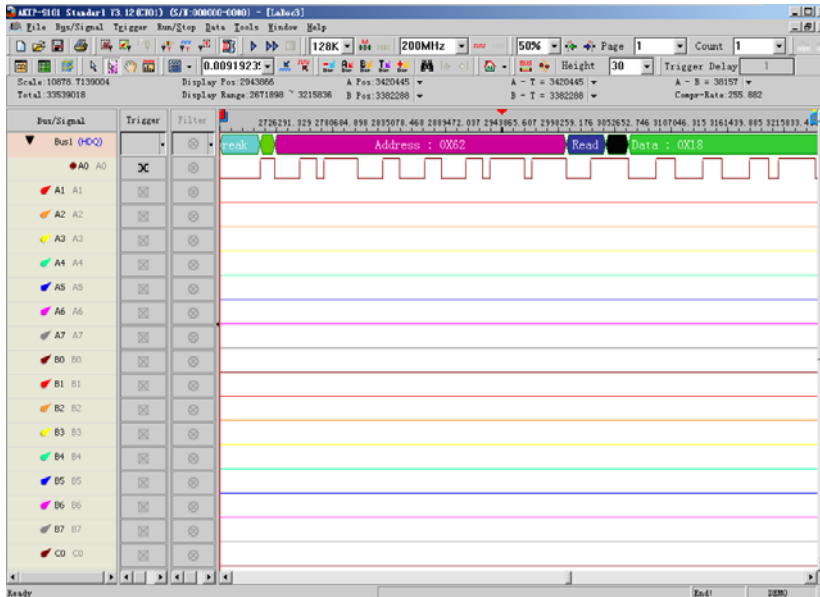

Fig4-118- Protocol Analyzer HDQ Decoding

4.5.6.2 Protocol Analyzer HDQ Packet Analysis

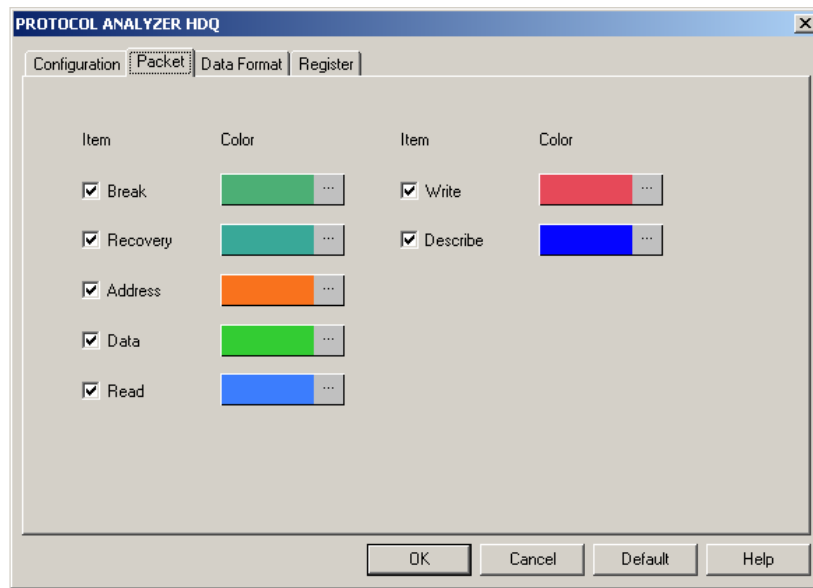

Fig4-119 - Protocol Analyzer HDQ Packet dialog box

Item: Select the content which needs to display in the Packet List, which includes Break, Recovery, Address, Data, Read, Write and Describe.

Color: Set color for items which needs to display in the packet list.

4.5.7 CAN 2.0B Analysis

Preface

Add Protocol Analyzer function to analyze CAN 2.0B transport protocols data. CAN 2.0B serial transmission, there are two signal channels, CANH and CANL, which match with baud ratio judge serial data. If you want to change serial data into Bus format, you need to analyze this function with LA. a dialog box needs to be added; you should set up a Protocol Analyzer CAN 2.0B dialog box.

CAN 2.0B Introduction

1. Brief Introduction

Features

CAN 2.0B (Controller Area Network) is an Asynchronous Transmission Protocol. It costs low, sky-high use rate, far data transmission distance (10KM), very high data transmission bit (1M bit/s), sending information without appointed devices according to message frame, dependable error disposal and detection error rule, message automatism renewal after damage, and node can exit Bus function on the serious error .

Applications

CAN 2.0B is used for automotive electronics correlation systems connection.

2. Protocol Analyzer Signal Specifications

Parameter	Value
Name of Protocol Analyzer	CAN 2.0B
Required No. of Channels	1
Signal Frequency	Not fixed, around 12MHz, 13MHz and 19,2MHz
Appropriate Sampling Rate	100MHz
Same Data Time Per Bit	<input type="checkbox"/> Yes <input checked="" type="checkbox"/> No
Name of Syn. Signals	CAN 2.0B
Data Verification Point	Low signals > 190us converts to High signals > 40us

3. Protocol Analyzer IO Description

Name	Function
CANL	The main signal source of transmission data
CANH	Signal is opposite to the signal source of transmission data

4. Protocol Analyzer Electrical Specifications

Parameter	Min.	Type	Max.	Unit	Note
Logic Input High	2.5			V	
Logic Input Low			0.5	V	

CAN 2.0B Frame Specification

CAN 2.0B can separate into frames as follows: Data Frame, Remote Transmit Request Frame, Error Frame, Overload Frame. Because CAN 2.0B is transmitted by the format of different signals, the signal can separate into CANL and CANH, and the signal direction of CANH is opposite to that of CANL. Next we analyze CAN 2.0B signal with the standard of CANL.

Basic Data Frame

Data frame can be divided into Basic CAN and Peli CAN, Data Frame of Basic CAN transmission. As follows,

message data can be separated into Start of Frame (SOB), Arbitration Field, Control Field, Data Field, CRC Field, Ack Field, End of Frame.

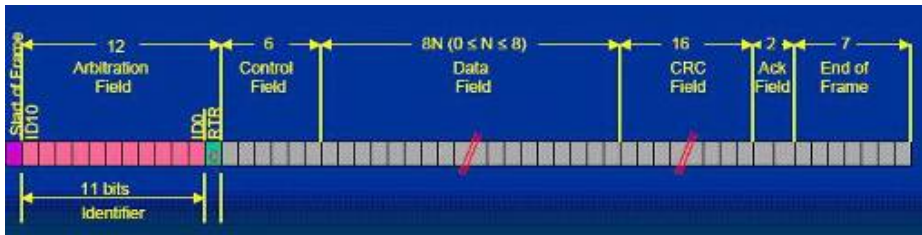

Fig4-120 - Basic Data Frame

Start of Frame

Every Start of Frame must be 0, which means asking for data to come back.

Arbitration Field

Identifier is 11 bits; its function is the sequence when transmitting signal, numerical value is lower, the priority is higher, and the array is from ID-10 to ID-0, and the numerical value is not all from ID-10 to ID-4, finally RTR(Remote Transmit Request) is the judgment bit of transmission or Remote Transmit Request. When RTR=0, it denotes that the data goes out; when RTR=1, it means asking for data to come back.

Control Field

Control Field consists of 6 bytes, including Data Length Code and two Reserved Bits as Peli frame for future expansion. The transmission reserved bit must be 0. Receiver receives all bits combining 1 with 0. As the below figure, IDE and RB0 of Control Field are Reserved Bits which must be 0 and the latter 4 bits are only 0-8 which denotes the data behind will transmit several bytes data.

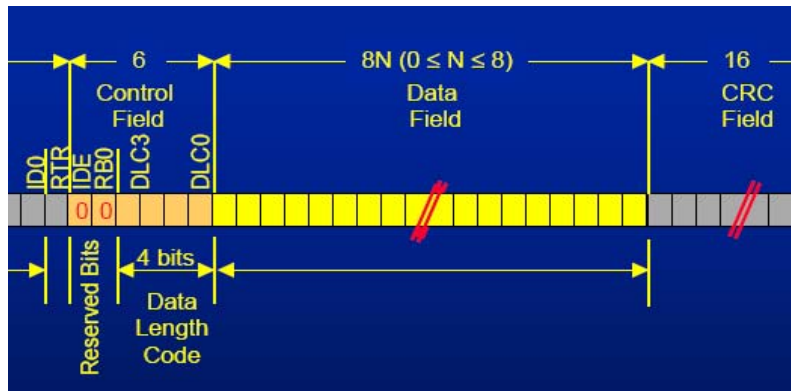

Fig4-121 - Control Field

Data Field

The Data Field consists of the data to be transferred within a Data Frame. It can contain from 0 to 8 bytes, and each contains 8 bits which are transferred MSB first.

CRC Field

16bits CRC, the last is a delimiter, and the default is 1.

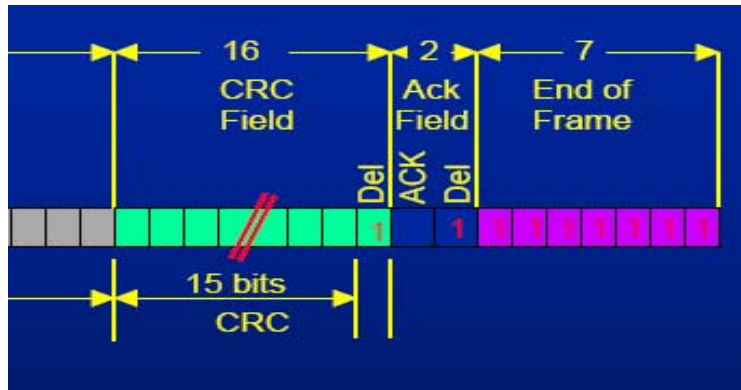

Fig4-122 - CRC Field

Ack Field

That is the return signal of Receiver, which has 2 bits, and the final is a delimiter whose default is 1. If receiving success, Ack will send back 0, then the transmitter knows the Receiver has received the data.

End of Frame

1111111 denotes end.

Peli Data Frame

In the Peli Data frame, Data Frame as follows, the frame of message is separated into Start of Frame (SOB), Arbitration Field, Control Field, Data Field, CRC Field, Ack Field, End of Frame. However, the parts of Arbitration Field have much more than 18bits and the SRR and IDE are 1.

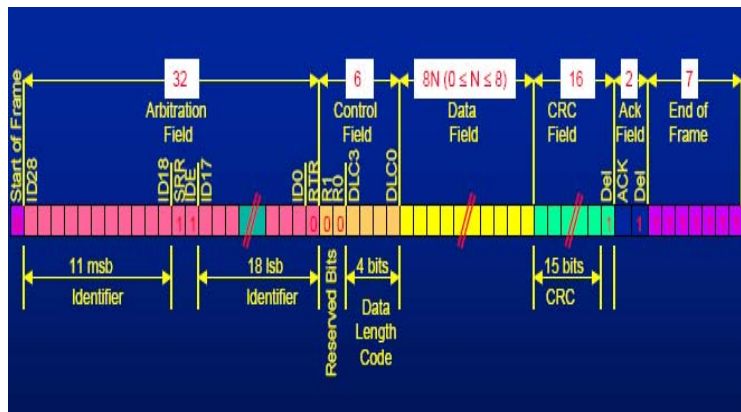

Fig4-123 - Peli Data Frame

Remote Transmit Request Frame

When RTR=1, it denotes Remote Transmit Request Frame, at this time, DLC3...DLC0 are the Data bytes of return data. And the frame doesn't have Data Field.

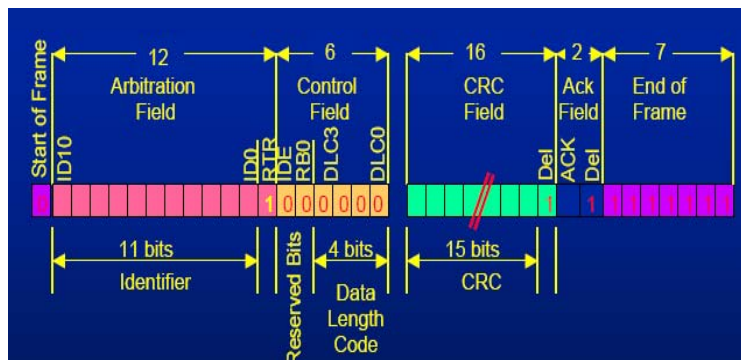

Fig4-124 - Remote Transmit Request Frame

Error Frame

The Active Error Flag consists of six consecutive Data Field 'dominant' bits. Dominant bits violate the law of bit stuffing. All bits can produce Error Frame after recognizing bit stuffing wrong, the Error Frame called Error. Corresponding Error Flag Field includes sequence bits from 6 to 12 (which produces by 1 or more nodes). Error Frame ends in Error Delimiter field. After Error Flag sends out Bus actively to get the right state, and the interrupted node tries its best to send abeyant message Error Delimiter. Error Delimiter consists of eight 'recessive' bits and allows Bus node to restart Bus transmission after Error happens.

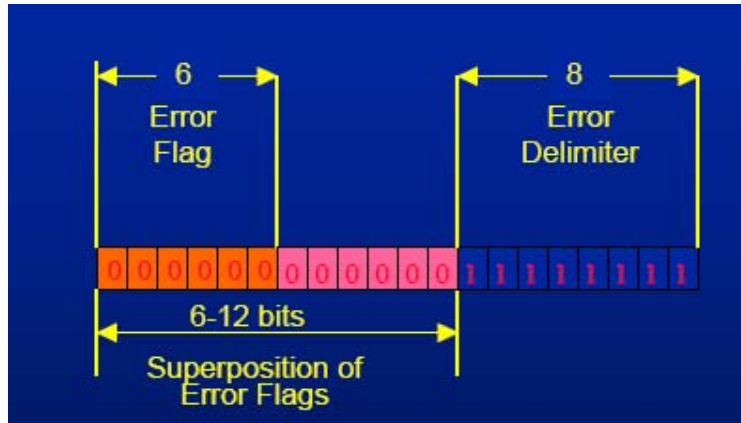

Fig4-125 - Error Frame

Overload Frame

There are two kinds of Overload conditions, which both lead to the transmission of an Overload Flag. The internal conditions of a node which require a delay of the next Data Frame start during the first bit of Intermission. Overload Flag can send six '0', which may damage Intermission format so that it makes the other nodes know node sending Overload Flag at this time. When Overload Flag is sent out, Overload Delimiter can send eight '1', others send seven '1' after finishing either.

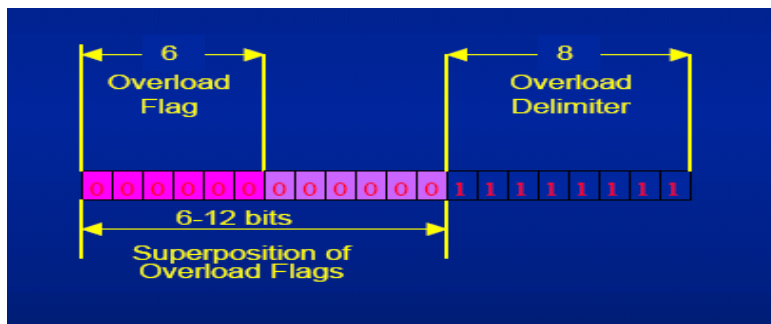

Fig4-126 - Overload Frame

Interframe Space

Interframe Space is divided into Intermission and Bus Idle. Intermission is three '1'. It is impossible to send any message during this time, except Overload Frame. The Bus is recognized to be free; the period of BUS IDLE may be of arbitrary length. And any station having something to transmit can access the Bus. When a node is at the state of 'error passive', the node will send eight '0' after INTERMISSION and other node have the chance to retransmit themselves information.

4.5.7.1 Software Basic Setup of Protocol Analyzer CAN 2.0B

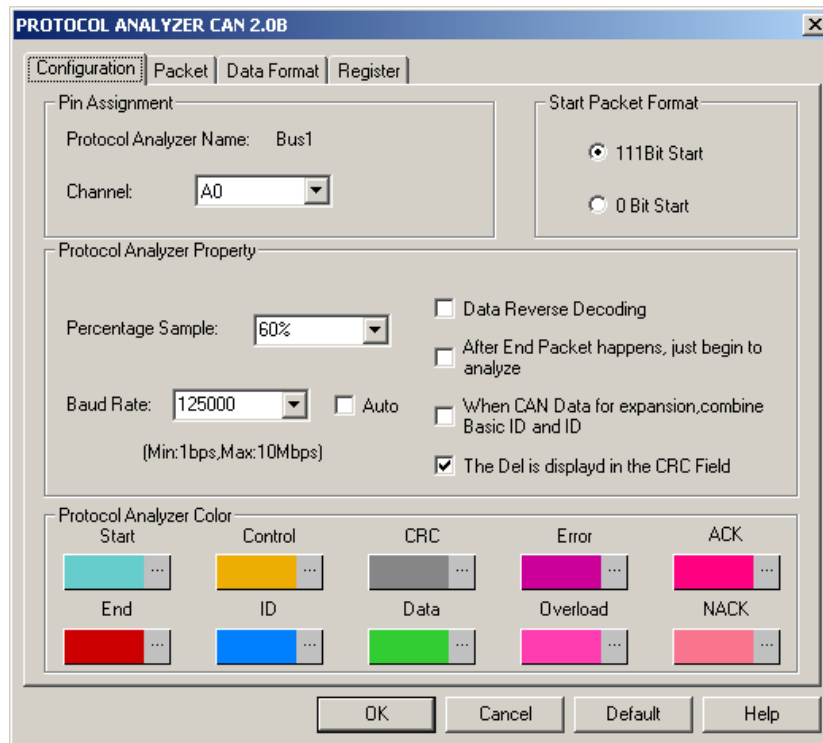

Fig4-127 - Protocol Analyzer CAN 2.0B Configuration dialog box

Set the **CAN 2.0B Configuration** dialog box

Pin Assignment:

Protocol Analyzer CAN 2.0B only needs one channel to decoding signals, the default channel is A0.

Start Packet Format: The Start Position can be divided into two formats, 111 Bit Start (the Start Position is that three bits are High.) and 0 Bit Start (the Start Position is that one bit is Low).

Protocol Analyzer Property:

Percentage Sample: The Percentage Sample should be entered in the position of the Baud Rate which is selected from the range between 25% and 75%, and the default of the Baud Rate is 60%. The resolution can be adjusted to 1%.

Baud Rate: The Baud Rate can be set to Integer or selected from the pull-down menu (10000, 20000, 40000, 50000, 80000, 100000, 125000, 200000, 250000, 400000, 500000, 660000, 800000 and 1000000) manually, and the default is 125000. If the Auto is selected, the Baud Rate can be calculated by the main program automatically and displayed on the CAN 2.0B dialog box.

Data Reverse Decoding: If it is selected, the data can be decoded in reverse.

After End Packet happens, just begin to analyze: If it is selected, the signal will be decoded when the End Packet appears.

When CAN Data for expansion, combine Basic ID and ID: If the option is selected, the Basic ID and ID will be combined.

The Del is displayed in CRC Field: If it is selected, the Del will be displayed in the CRC Field.

Protocol Analyzer Color:

The protocol analyzer colors can be varied by users.

Operating Instructions

Open the user interface of the Logic

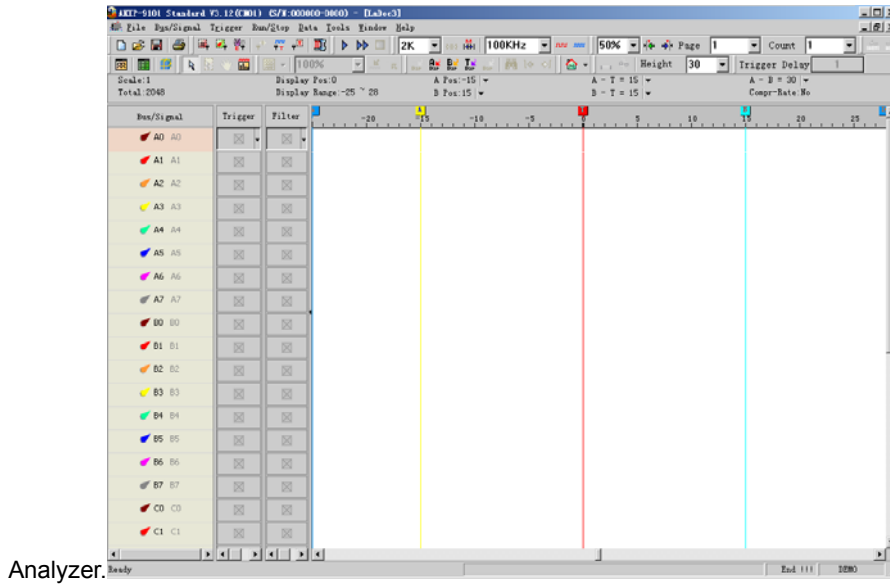

Analyzer.

Fig4-128 - User Interface

Sample the CAN 2.0B signal or open the sampled waveform.

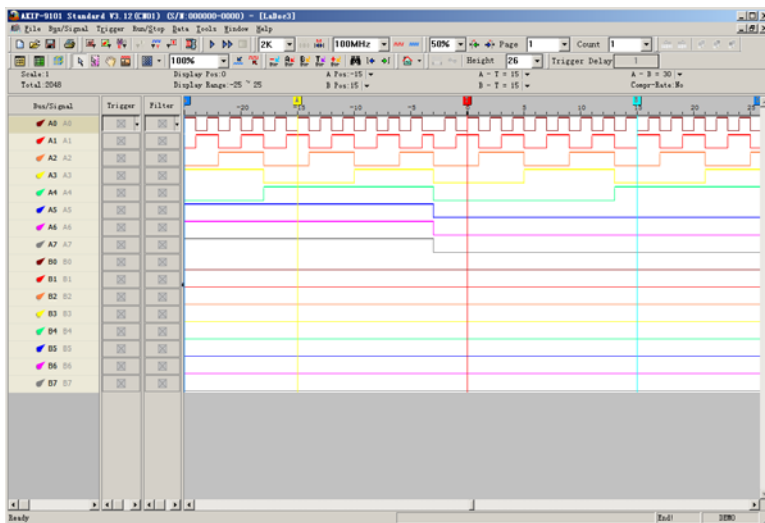
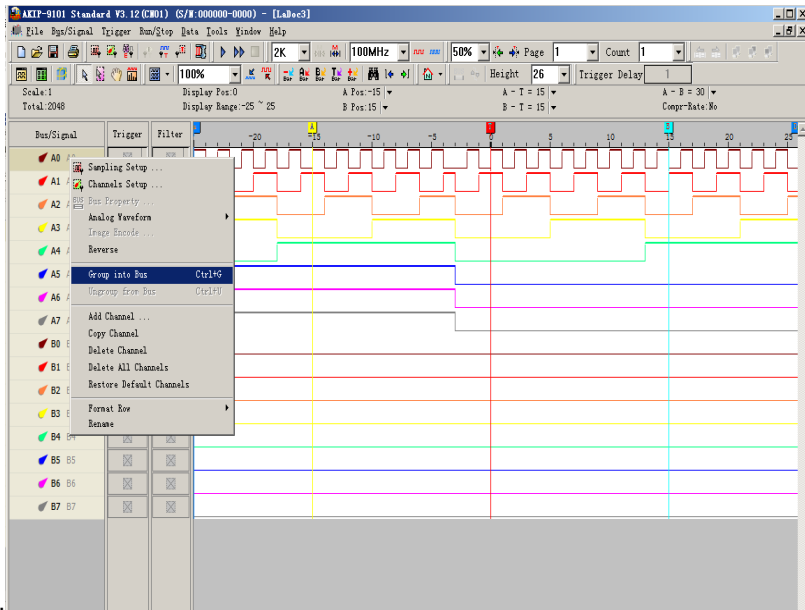

Fig4-129 - CAN 2.0B Waveform

Group the signal channels into



Bus.

Fig4-130 - Group into Bus

Select the **Bus Property** to set up the Bus Property dialog

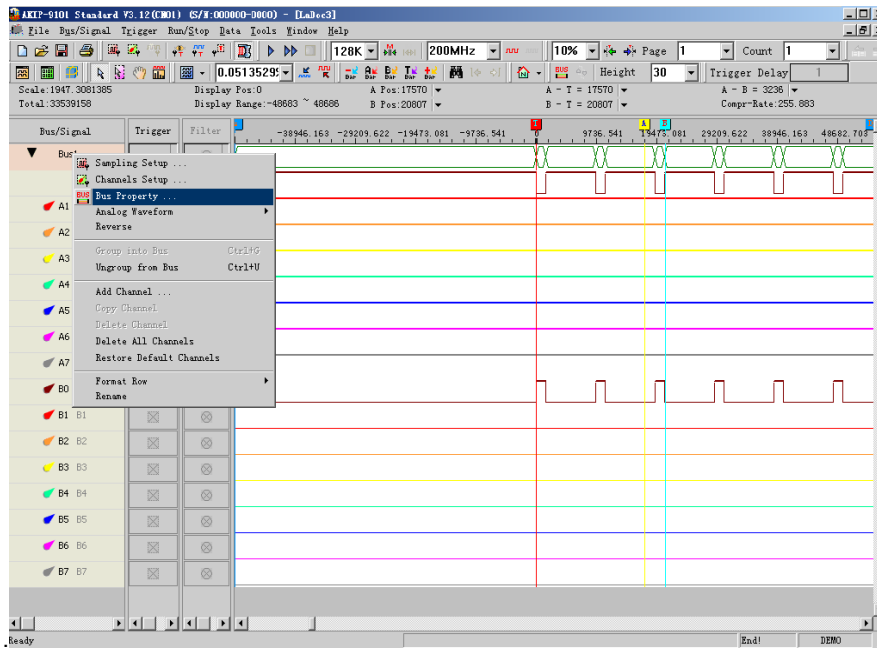

box

Fig4-131 - Bus Property

Select the decoding function of the Protocol Analyzer CAN 2.0B and select **OK** to

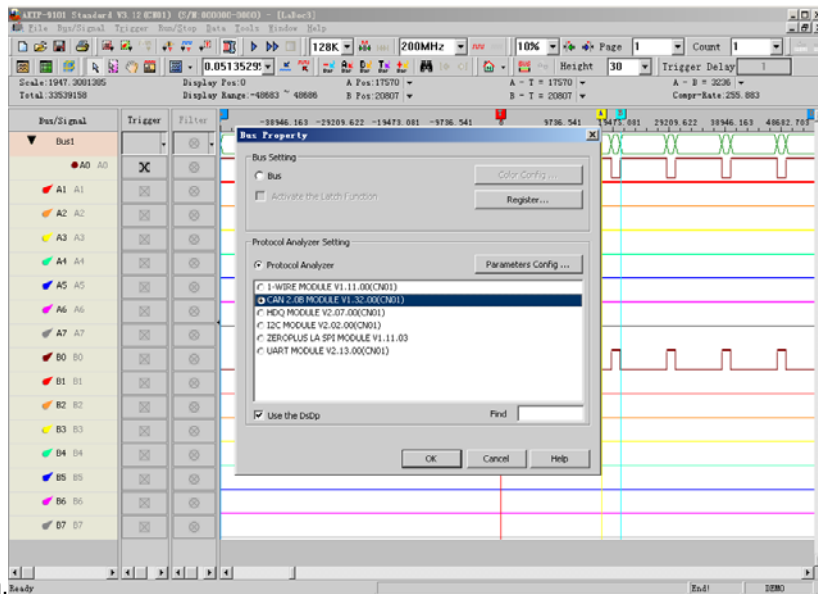

confirm.

Fig4-132 - CAN 2.0B Bus Property Setup

Double click the CAN 2.0B MODULE V1.32.00 (CN01) to set the Protocol Analyzer CAN 2.0B dialog box.

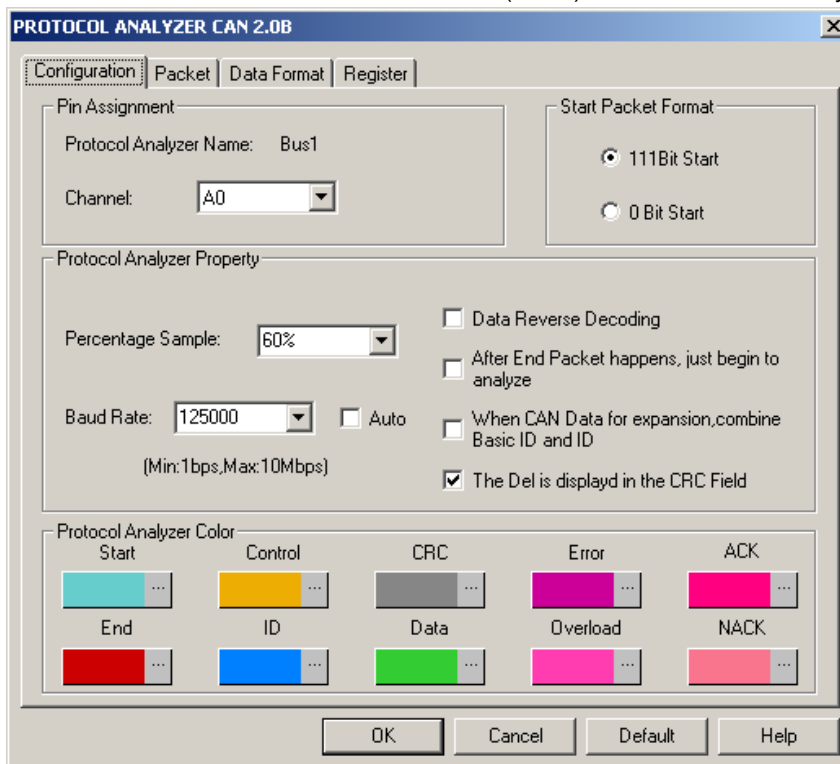

Fig4-133 - Protocol Analyzer CAN 2.0B Setup

Click **OK** in the Protocol Analyzer CAN 2.0B dialog box to complete the CAN 2.0B Setting.

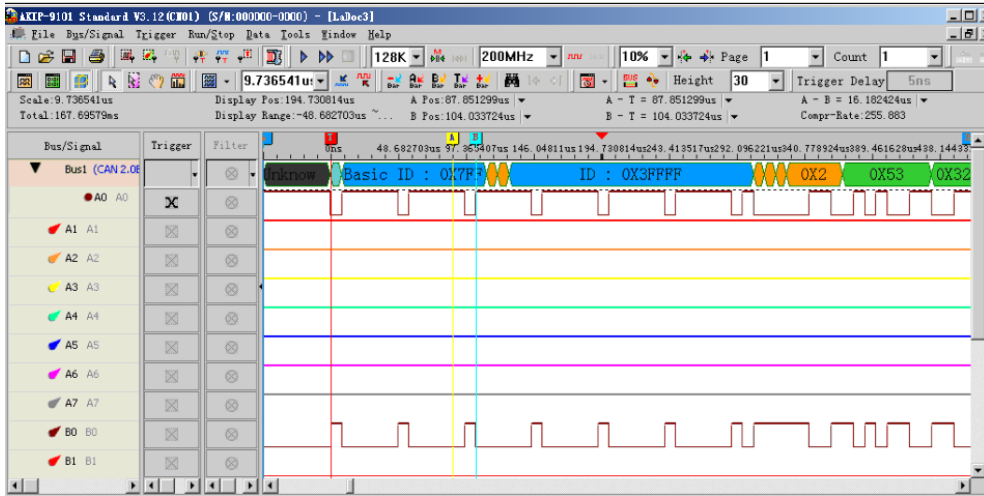

Fig4-134 - CAN 2.0B Decoding

4.5.7.2 Protocol Analyzer CAN 2.0B Packet Analysis

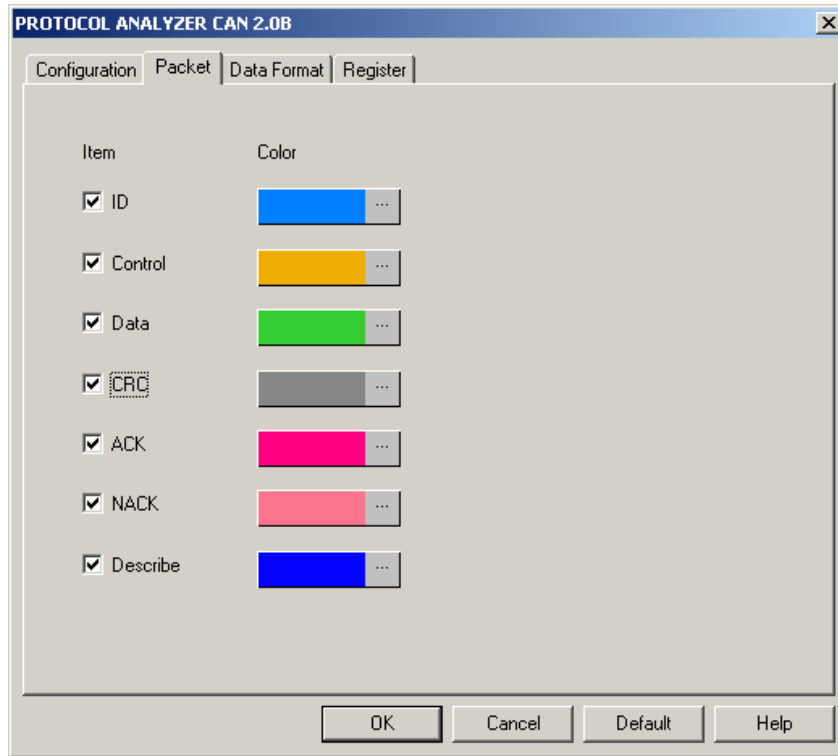

Fig4-135 - Protocol Analyzer CAN 2.0B Packet dialog box

Packet color can be varied by users.

The Packet displays with the waveform as below:

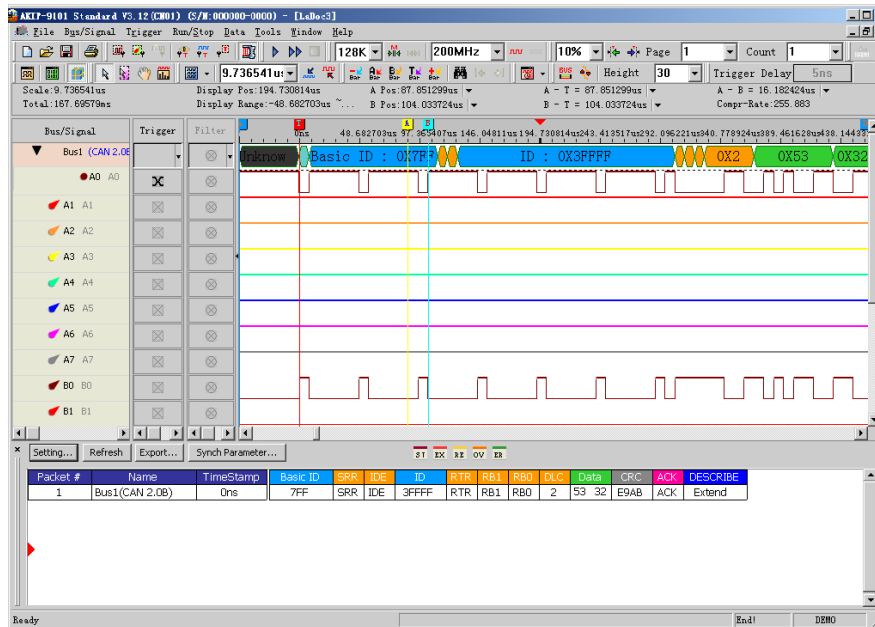

Fig4-136 - CAN 2.0B Packet List Displayed with the Waveform

4.6 Compression

The Compression function enables the system to compress the received signal and has more data stored in per channel.

4.6.1 Software Basic Setup of Compression

Step1. Set up RAM Size, Frequency, Trigger Level and Trigger Position as described in Section 4.1.

Step2. Set up the trigger edge on the signal or the Bus to be triggered.

Step3. Click  icon, or click the Compression function from the Sampling Setup dialog box then click **Apply** and **OK** to run.

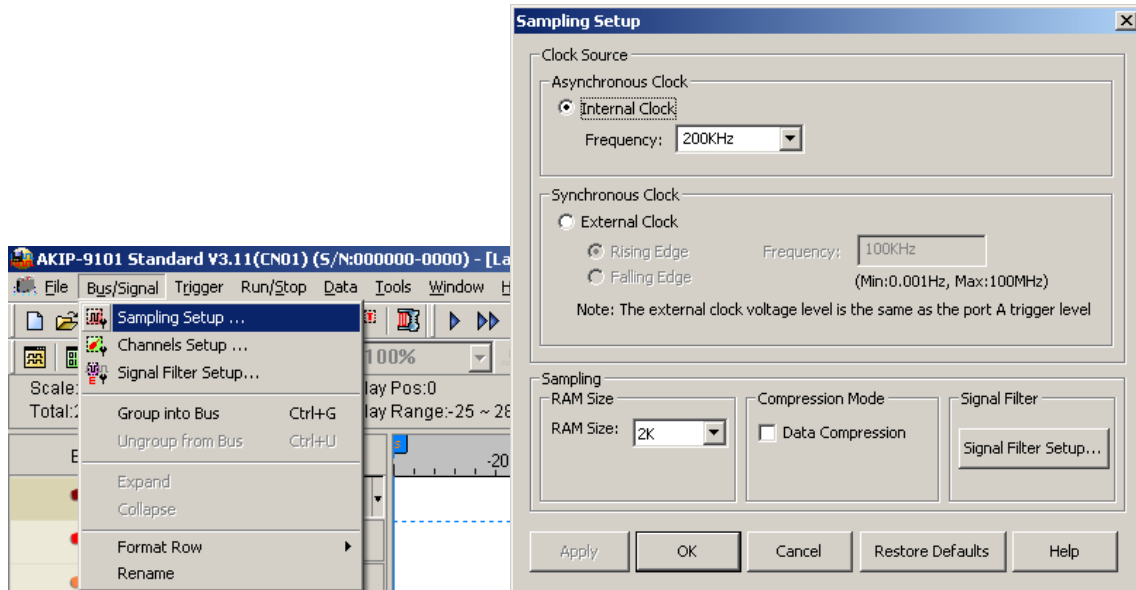
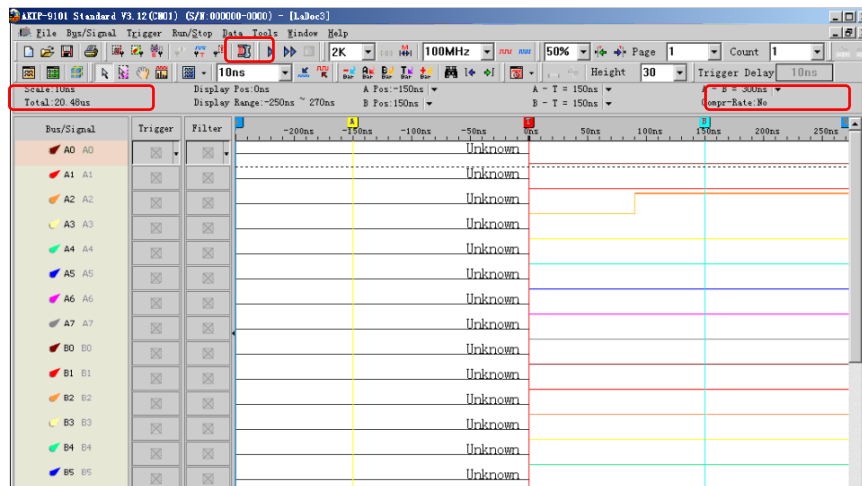

Fig 4-137 – Compression Mode

Step4. Click **Run**, and then activate the signal from the tested circuit to acquire the result on the waveform display area. Fig 4-138 shows the result before and after compression has been applied.



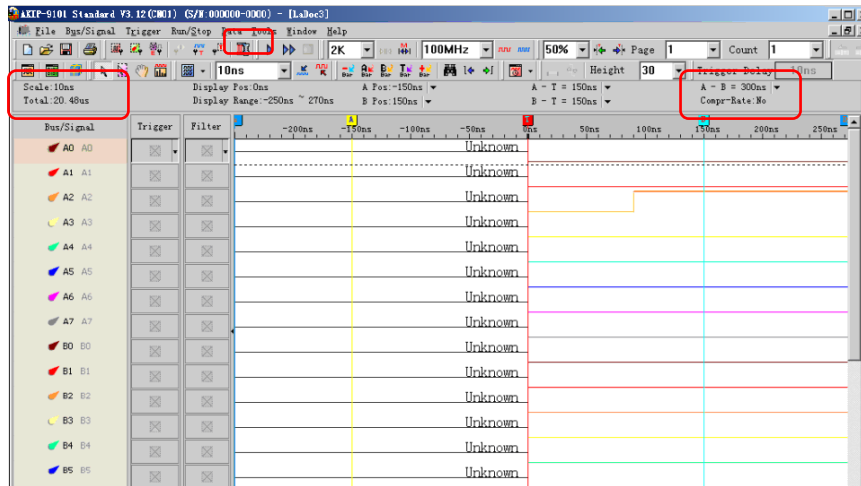



Fig 4-138 – Before and After Compression

Using 128K memory depth, before Compression has been applied, the total of the data was 20.48us ; after the Compression had been applied, the total of the data was 205.23us, therefore, the compression rate is 10.021.

Tip: Click  icon to view all data, and then select the waveform analysis tools to analyze the waveforms.

Step5. Click the compression icon again or click off the compression function to stop compression.

Tip: Compression cannot be applied with the signal filter function at the same time.

4.7 Signal Filter and Filter Delay

The function of the Signal Filter and Filter Delay allow the system to keep the required waveform, and filter out the waveforms that aren't required.

4.7.1 Basic Setup of Signal Filter and Filter Delay

Software Basic Setup of Signal Filter and Filter Delay

Step1. Set up RAM Size, Frequency, Trigger Level and Trigger Position as described in Section 4.1.

Step2. Set up the trigger edge on the signal or the Bus to be triggered.

Step3. Click  icon, or click the Signal Filter Setup button on the Sampling Setup dialog box or select the item from the pull-down menu of the Bus/Signal and then the Signal Filter Setup dialog box will appear.

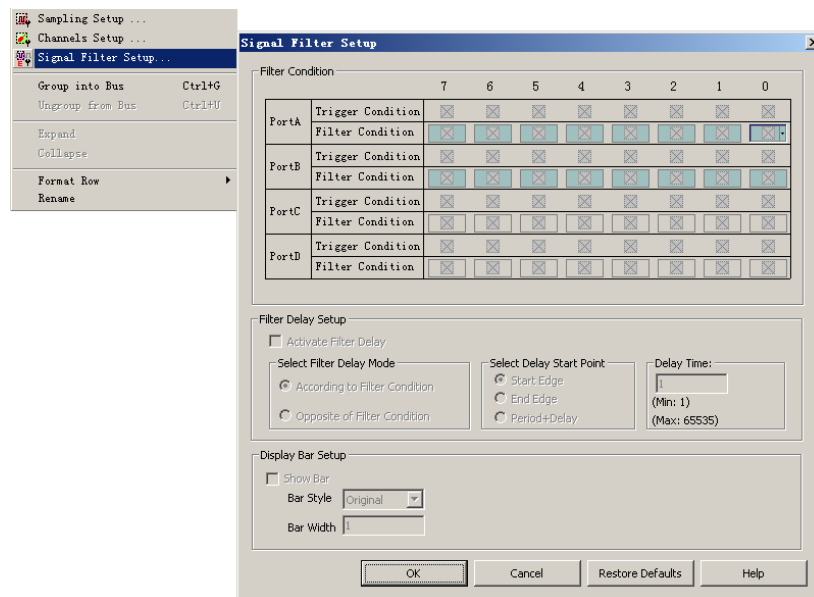



Fig 4-139 – Signal Filter Setup

Set the high level as Filter Condition on the signal A1.

Step4. Signal Filter Setup

1. Setup the Filter Condition as  or  on the signal to be analyzed.
2. Click **OK**, then click **Run** to activate the signal from the tested circuit to the Logic Analyzer.
3. The system will display only the waveforms of the signals which are qualified by the Filter Condition.

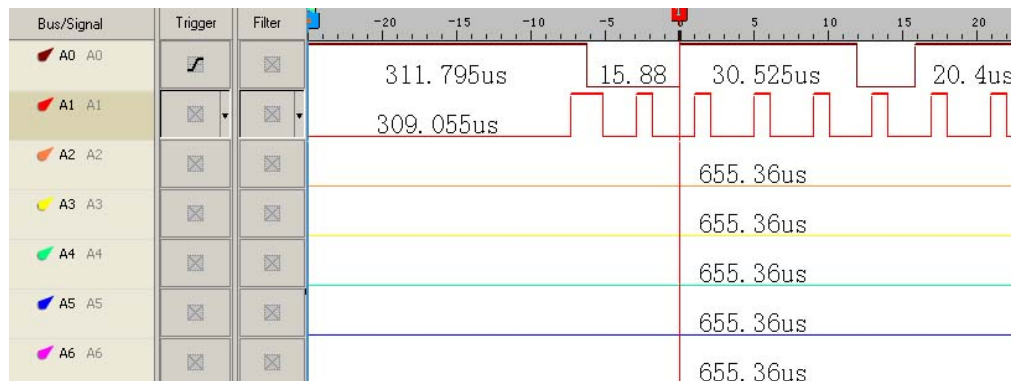



Fig 4-140 – Without/With Signal Filter Setup

The first picture shows the result without any signal filter setup.

The second picture shows the result which has set the high level on the Filter Condition of the signal A1. Only the waveform with the high status of A1 is displayed.

Step5. Filter Delay Setup

1. Click on the **Activate Filter Delay** as shown in Fig 4-141.
2. Click on the **According to Filter Condition** or the **Opposite of Filter Condition** to select the waveforms to be kept.
3. Click on the **Start Edge**, **End Edge** or **Period + Delay** to set the Start Point of Filter Delay.
4. Type the value of the Delay Time into the column of the **Delay Time**.
5. Click **OK**, then click **Run** to activate the signal from the tested circuit to the Logic Analyzer.
6. The result will be displayed in the waveform display area as shown in Fig 4-140.

Step6. Stop Signal Filter/ Filter Delay

Click **Stop**, then click **Signal Filter Setup** and select **Cancel** from the Signal Filter Setup dialog box to stop the Signal Filter or the Filter Delay Setup.

Tip: Click **Stop** to check the conditions of the Signal Filter or the Filter Delay Setup, if there aren't any results.

Tip: Click  icon to view all the data, and then select the waveform analysis tools to analyze the waveforms.

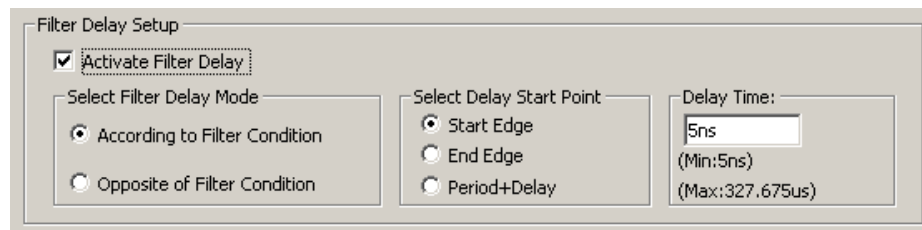

Fig 4-141 – Filter Delay Setup

Tip: Definitions of the **Start Edge** and the **End Edge** and the **Period + Delay** are listed as Figs 4-142, 4-143, 4-144 and 4-145.

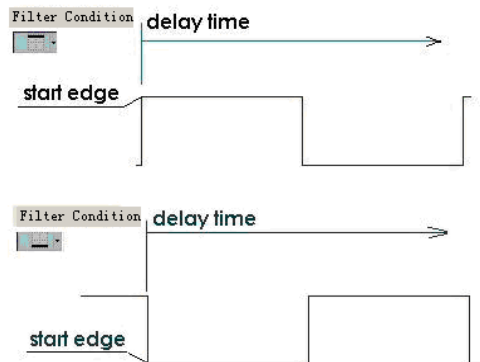

Fig 4-142 – Start Edge

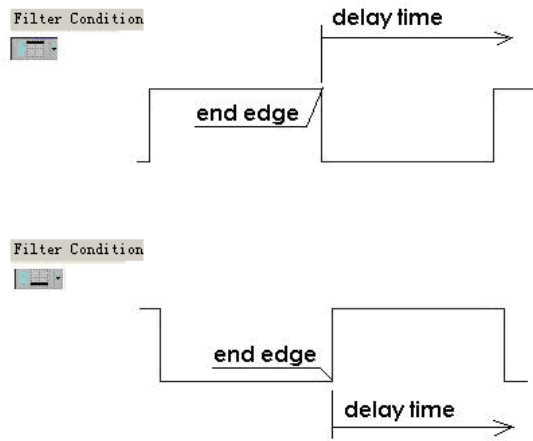

Fig 4-143 – End Edge

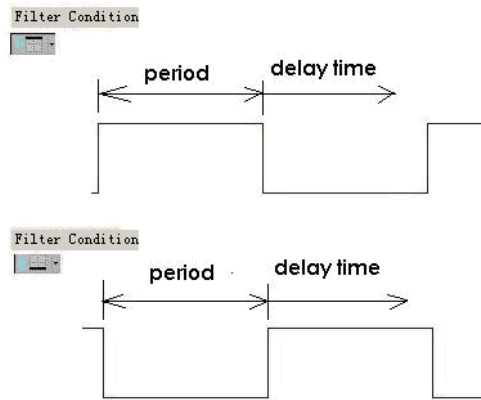

Fig 4-144 – Period + Delay

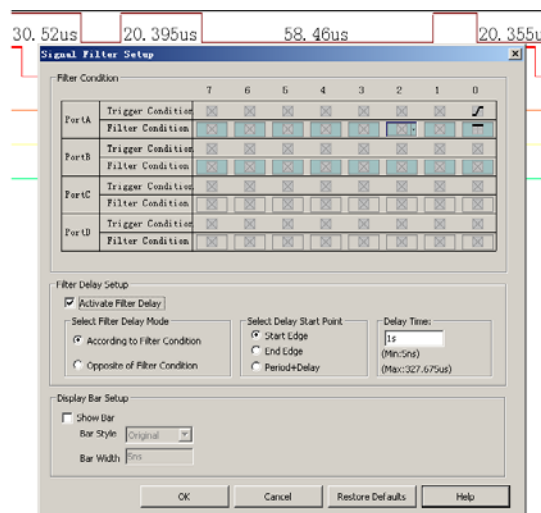

Fig 4-145– Filter Delay Setup

The delay time of signal A0 is 1 us, which is the condition of the Filter Delay Setup.

Step 7. Signal Filter Time Interval

1. Click **Show Bar** to know the length of the tested and deleted signal as shown in Fig4-146 below.

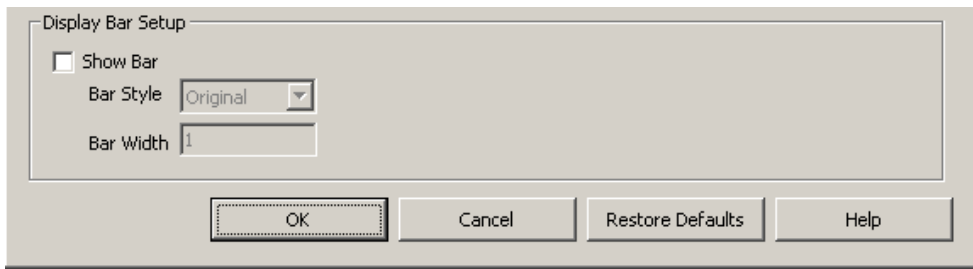

Fig4-146 - Display Bar Setup

2. The bar has two styles, which are Original and Bar; the default is Original style, which denotes the bar function cannot be used. When selecting Bar style, the bar function can be activated.
3. Bar Width, when Bar style is selected, the bar width can be set by users.

Tip: The minimum bar width is 1; the maximum bar width is 65535. If the value exceeds the range, or the font is not according to the requirement, a tip window will appear.

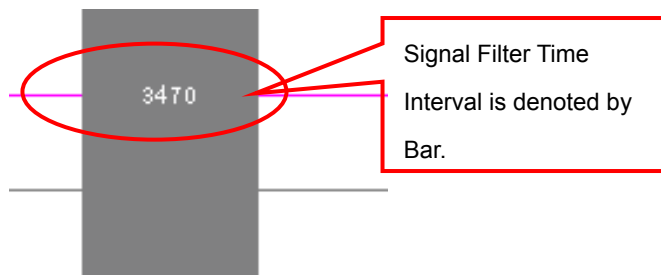

Fig4-147 - Signal Filter Time Interval

Tip: The Signal Filter Time Interval is limited under the following situations:

- A: The Filter Delay and Display Bar of Signal Filter are not available under the compression mode.
- B: The Filter Delay and Display Bar of Signal Filter are not available under the double mode.
- C: The final two data are NULL.
- D: Logic Analyzer supports the Signal Filter Time Interval function on condition that the time interval between signal filter must be more than two clocks.

4.8 Noise Filter

The Noise Filter function enables the system to filter the waveform that doesn't meet users' requirements.

4.8.1 Basic Software Setup of Noise Filter

STEP1. Click **Data** on the Menu Bar, then select  Noise Filter to activate the noise filter function as the figure below.

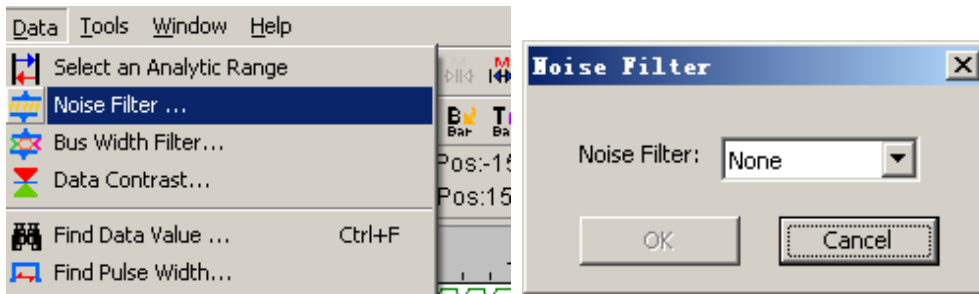

Fig4-148 - Noise Filter

STEP 2. Transmit the tested signal to the Logic Analyzer as the figure below.

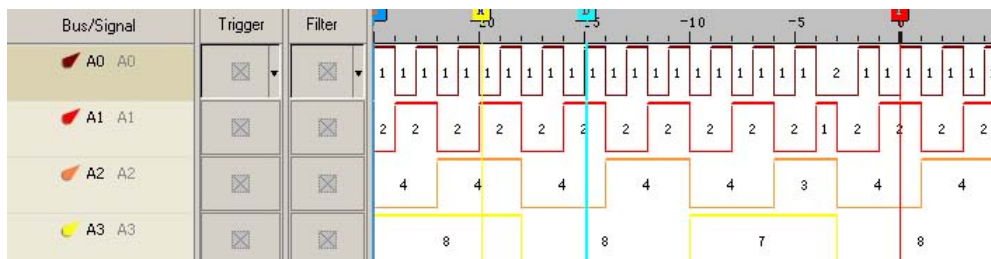

Fig4-149 - Tested Signal

STEP 3. Filter waveforms that are not bigger than 5 clocks.

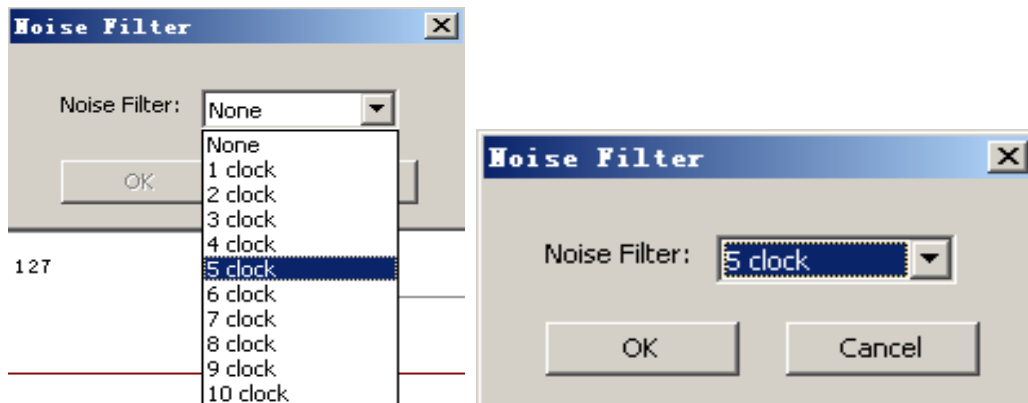

Fig4-150 - The condition of Noise Filter is 5clock.

STEP 4. After filtering, the waveforms that are not bigger than 5 clocks are deleted.

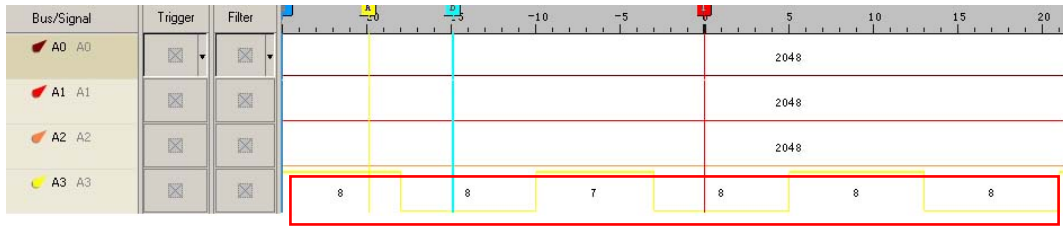

Fig4-151 - Waveforms after Filtering

STEP 5. Reserve the original waveform: open the Noise Filter window, and then select None, the waveform will be restored.

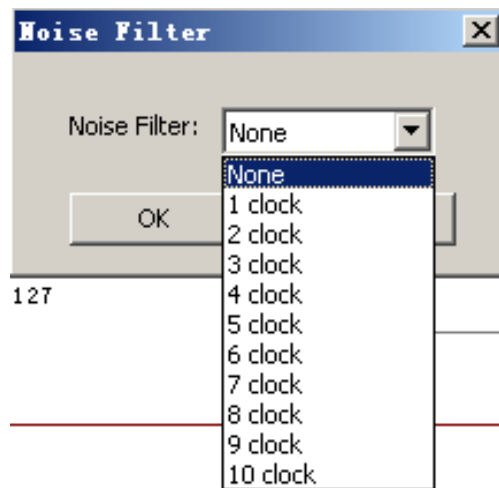

Fig4-152 - Restore the Waveform

4.9 Data Contrast

In order to make users analyze the Data and contrast the difference of Data easily, there are adding the function of Data Contrast. The function of Data Contrast is used to compare the difference of two signal files of the same type. One is the Basic File and the other is the Contrast File. It can line out the different waveform segments of the basic file in the contrast file. Meanwhile, it can count the number of the difference.

4.9.1 Basic Software Setup of Data Contrast

STEP 1. Click **Data** on the Menu Bar, then select  to open the Data Contrast Settings dialog box.

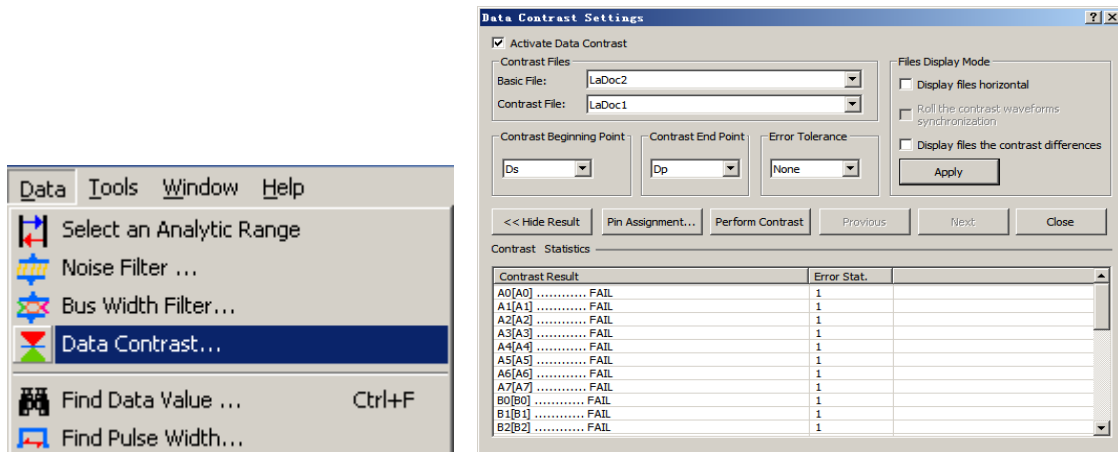

Fig4-153 - Data Contrast Interface

Activate Data Contrast: Click the checkbox to activate the function of Data Contrast.

Basic File: It is the standard contrast file.

Contrast File: It is used to compare with the Basic File.

Contrast Beginning Point: Select the point to begin the contrast, based on the basic file.

Contrast End Point: Select the point to end the contrast, based on the basic file.

Error Tolerance: It is the allowable time error when setting data contrast.

Display files horizontal: Display the two files horizontally to see the contrast more clear. It is not selected by default.

Roll the contrast waveforms synchronization: Roll the two horizontal files synchronously. It can be selected after **Display files horizontal** is selected.

Pin Assignment: Users can select the contrastive channel.

Perform Contrast: It can activate the Contrast at once.

Contrast Result: It displays the same contrasted result and the different contrasted result with PASS and FAIL respectively.

Error Stat. : It displays the number of discrepant parts.

Tip: For this function, Data Contrast, we provide the SDK Development Tool for users. Users can customize the Data Contrast Interface according to their requirements. We has packed the Data Contrast UI as the GUI.DLL and designed an interface which is used for the communication between the GUI.DLL and Main Program. The GUI adopts the Non-modal Interface design, which can make the GUI Interface and Main Program Interface switch freely. When users activate the Data Contrast function, the software will search whether there is a GUI. DLL or not,

then it can judge whether there is a user-defined Interface. If there is a user-defined Interface, the GUI.DLL will take effect; if there isn't, the embedded Data Contrast Interface will be activated.

STEP 2. Display the contrast results in the Data Contrast dialog box.

Tip: After pressing Perform Contrast, it will display the contrast information in the contrast result. The below contents of the box are the contrast information. The information is relative simpleness; if users don't want to understand more details, you can know whether the signals of the two contrast files are completely the same or not.

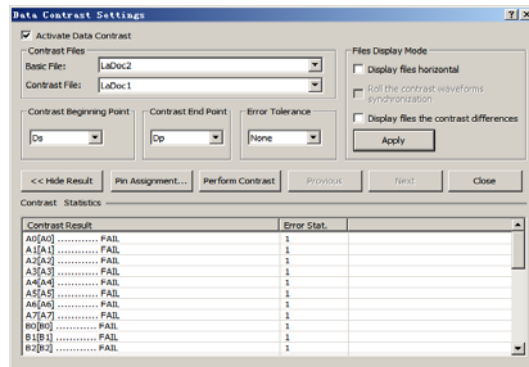

Fig4-154 - Display the Contrast Results in the Data Contrast Settings Dialog Box

A0[A0].....FAIL: It indicates that there are differences in the channels of the two files.

B0[B0].....PASS: It indicates that there is no difference in the channels of the two files.

STEP 3. Display the contrast results in the waveform windows. See the figure below.

Tip: It contrasts the two data files in the waveform area. The contrast waveform and the basic waveform are displayed horizontally; we can roll the mouse to contrast the waveform files; the difference of the waveforms will be lined out with the red wave line “~~~~~” in the contrast files.

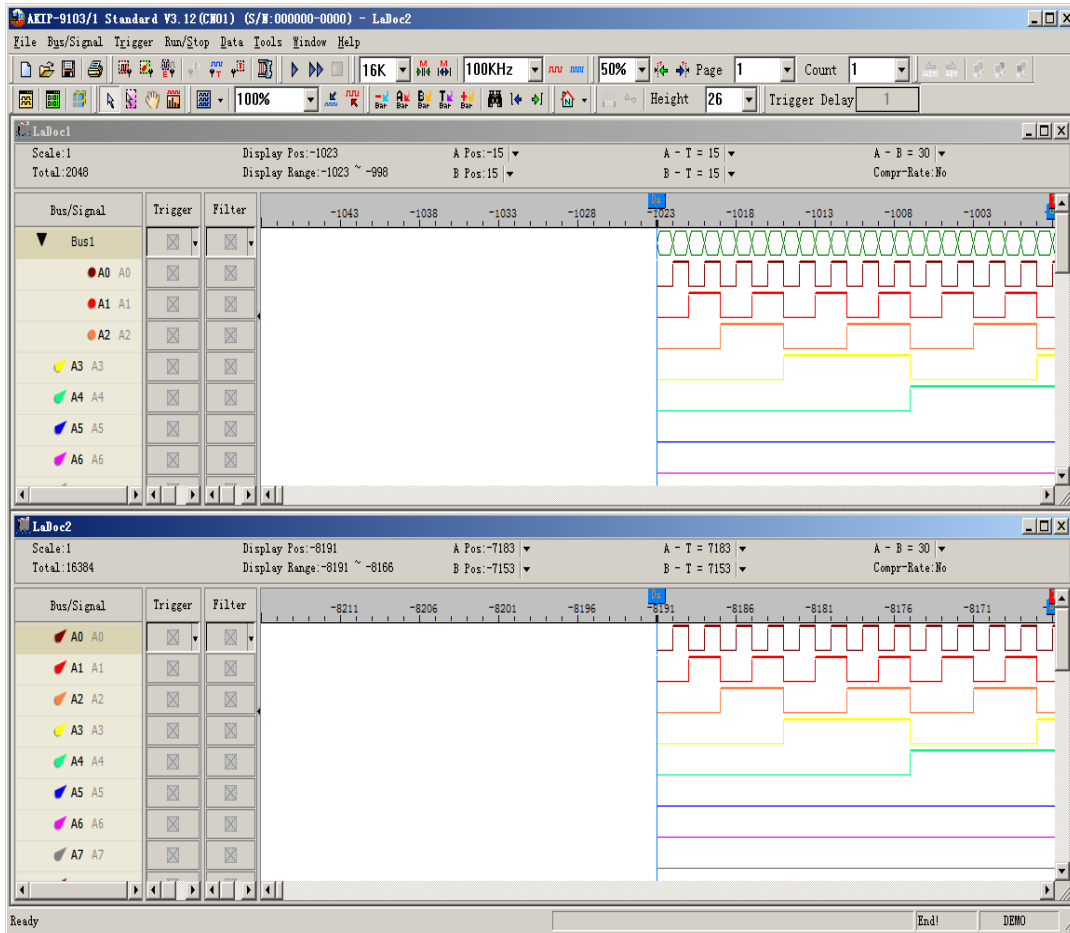

Fig4-155 - Display the Contrast Results in the Waveform Windows



Tip:

The Data Contrast function is available for the AKIP-9103 and AKIP-9103/1Module, and it is not available for the AKIP-9101 and AKIP-9102 Modules.

4.10 Refresh Protocol Analyzer

The Refresh Protocol Analyzer function enables the system to analyze the data between Ds and Dp again.

4.10.1 Basic Software Setup of Refresh Protocol Analyzer

STEP 1. Click **Tools** on the Menu Bar, then select  or click  on the Tool Bar directly to refresh Protocol Analyzer.

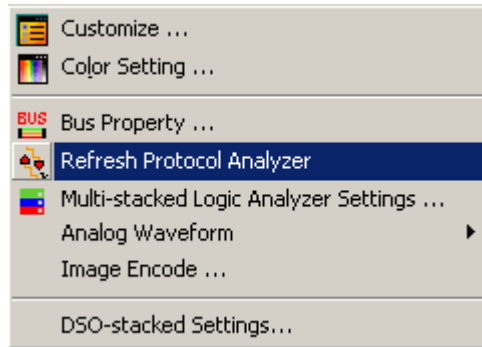

Fig4-156 - Refresh Protocol Analyzer

STEP 2. Transmit the tested Protocol Analyzer signal to the Logic Analyzer, for example Protocol Analyzer SPI.

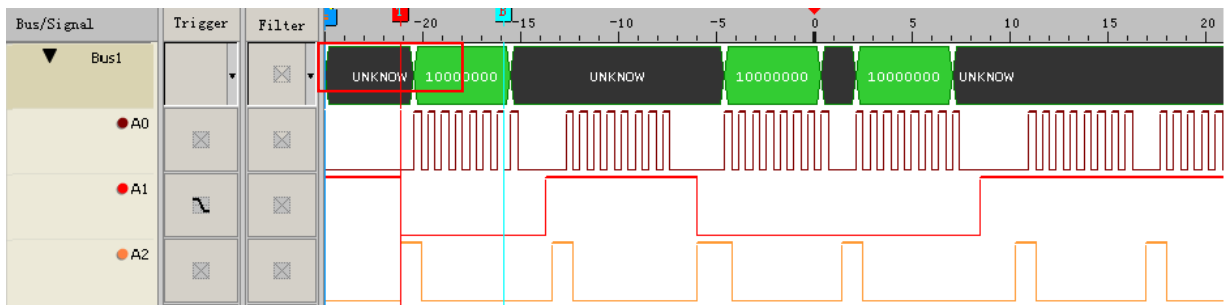

Fig4-157 - Waveform before Refreshing

STEP 3. Choose **Select an Analytic Range** to select the analysis range, and drag Ds Bar to B Bar.

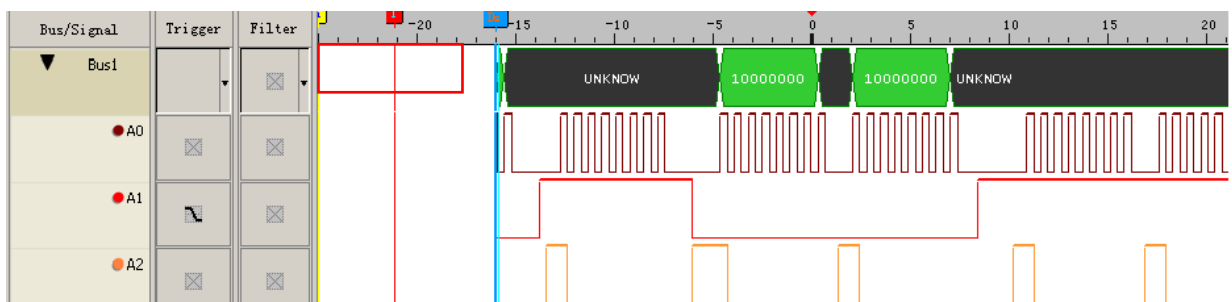



Fig4-158 - Drag Ds Bar to B Bar

STEP 4. Click , the Logic Analyzer will analyze the data between Ds and Dp.

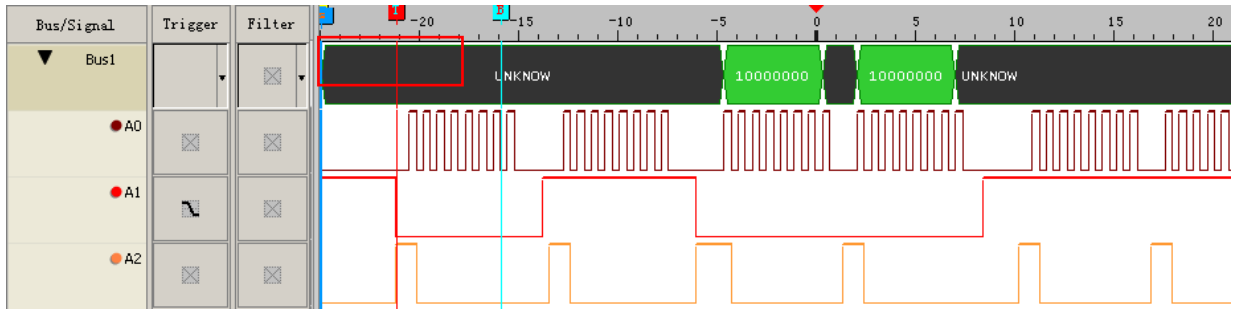



Fig4-159 - Analyze the Data Between Ds and Dp

STEP 5. Click  again, the waveform return the original state.

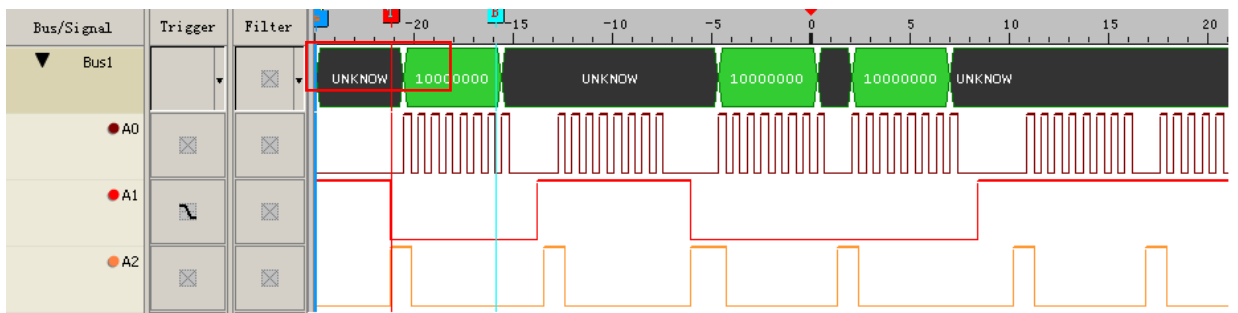

Fig4-160 - Restore the Original State

Tip: The Refresh Protocol Analyzer function can come into effect, while the Ds and Dp are activated.

4.11 Multi-stacked Logic Analyzer Settings

The function of the Multi-stacked Logic Analyzer Settings is mainly for connecting the hardware of many Logic Analyzers which are the same type, and then use the software to stack the Logic Analyzers which are working independently. It can improve the functions of the Logic Analyzer, which are mainly manifested in two aspects, expanding the RAM Size and adding the number of the test channels.

Tip:

1. The max. number of the Multi-stacked Logic Analyzers is four. The RAM Size of the four Logic Analyzers can reach to 128K*4 and the test channels of the four Logic Analyzers can reach to 32*4.
2. The function of the Multi-stacked Logic Analyzer Settings is available for the AKIP-9102, AKIP-9103 and AKIP-9103/1Modules, and it is not available for the AKIP-9101Module.

4.11.1 Basic Software Setup of Multi-stacked Logic Analyzer Settings

STEP 1. Click **Tools** on the Menu Bar, then select  to activate the function of Multi-stacked Logic Analyzer Settings.

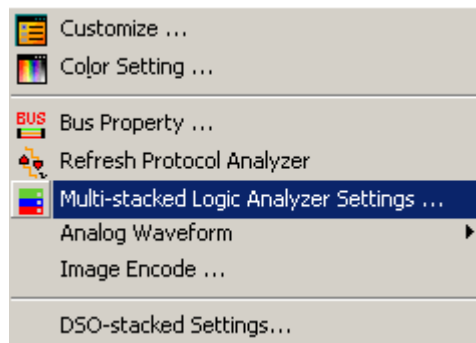

Fig4-161- Multi-stacked Logic Analyzer Settings Interface

STEP 2. Click  to open Multi-stacked Logic Analyzer Settings dialog box.

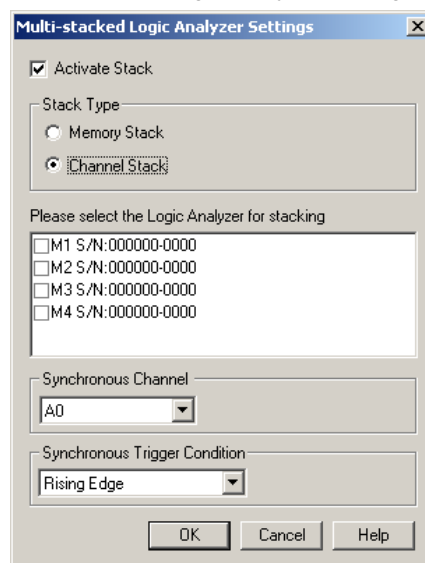

Fig4-162 - Multi-stacked Logic Analyzer Settings Dialog Box

Activate Stack: Click the checkbox to activate the function of the Multi-stacked Logic Analyzer; the default is non-activated.

Stack Type: Users can select the Memory Stack and Channel Stack; the default is the Channel Stack.

Please select the Logic Analyzer for stacking: It can display all the connected Logic Analyzers and the S/N code of them. The M1 indicates the first Logic Analyzer and the M2 indicates the second Logic Analyzer; M3 and M4 are similar to the previous. Users should select two or more Logic Analyzers, but the most analyzers users can select is four.

Synchronous Channel: Select the synchronous channel form the pull-down menu. The default synchronous channel is A0.

Synchronous Trigger Condition: Select the synchronous trigger condition. Users can select the Rising Edge, Falling Edge, High and Low from the pull-down menu. The default is the Rising Edge. The function of the Synchronous Trigger Condition can only be used in the Channel Stack, that is to say, it is disabled in the Memory Stack.

STEP 3. Display the function of Multi-stacked Logic Analyzer in the Memory Stack.

Tip: There are two Logic Analyzers to do the Memory Stack; the Synchronous Channel is A0; the data on the left of A Bar is captured by the first Logic Analyzer, the data on the right of A Bar is captured by the second Logic Analyzer.

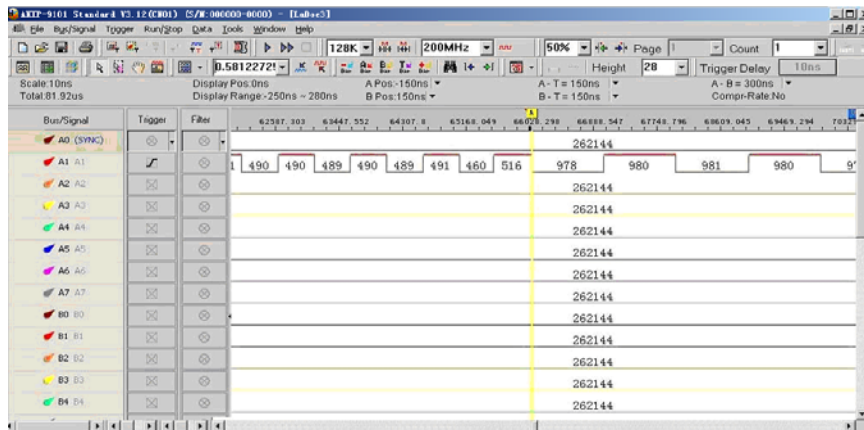

STEP 4. Display the function of Multi-stacked Logic Analyzer in the Channel Stack.

Tip: There are two Logic Analyzers for Channel Stack; the Synchronous Channel is A0; the Synchronous Trigger Condition is the Rising Edge; the former 32 channels (A0~A7, B0~B7, C0~C7, D0~D7) change into the 64 channels (A0~A7, B0~B7, C0~C7, D0~D7, E0~E7, F0~F7, H0~H7, I0~I7) channels.

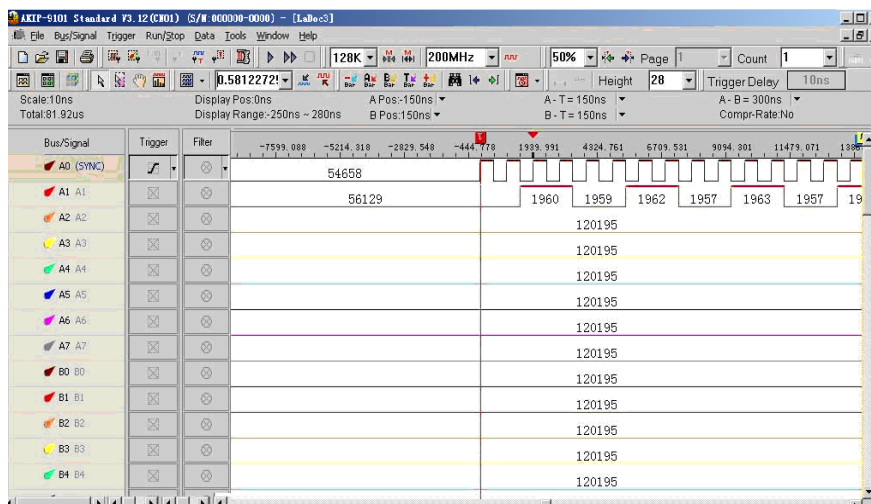

4.12 DSO-stacked Settings

To use the DSO-stacked function between Logic Analyzer and DSO, it is necessary to install specialized software to connect if using the DSOs produced by other manufactures except our company.

■ If Tektronix oscilloscope is used for stacking, please download the **TEKVISA CONNECTIVITY SOFTWARE V3.3.4** version or higher from the Tektronix Website.

■ If OWON oscilloscope is used for stacking, please download the Windows USB Driver from the OWON Website(<http://www.owon.com.cn>).

■ If PICO oscilloscope is used for stacking, please download the Windows USB Driver from the PicoScope Website(<http://www.picotech.com>).

■ If GwInstek oscilloscope is used for stacking, please download the Windows USB Driver from the GwInstek Website(www.gwinstek.com).

■ If Agilent oscilloscope is used for stacking, please download the Windows USB Driver from the Agilent Website(www.chem.agilent.com).

■ If BK Precision oscilloscope is used for stacking, please download the Windows USB Driver from the BK Precision Website(www.bkprecision.com).

Supported DSO Models:

Oscilloscope Manufacturer	Models	On-line Mode
Tektronix	TDS1000 Series	USB
	TDS2000 Series	USB
	TDS3000 Series	USB, TC/IP, GPIB
	TDS5000 Series	GPIB
	TDS6000 Series	In-built GPIB
OWON	SDS7102 Model	USB
PicoScope	3206B Series	USB
GwInstek	GDS-1000A Series	USB
	GDS-3000 Series	USB
Agilent	DSO5000 Series	USB
BK Precision	2540B, 2542B, 2540B-GEN, 2542B-GEN	USB

Operating Mode

(1) Host-Slave

LA is the Host, DSO is the Slave. Connect the Trigger Out of LA with the Trigger In of DSO, when LA has been triggered, it will inform DSO to capture signal.

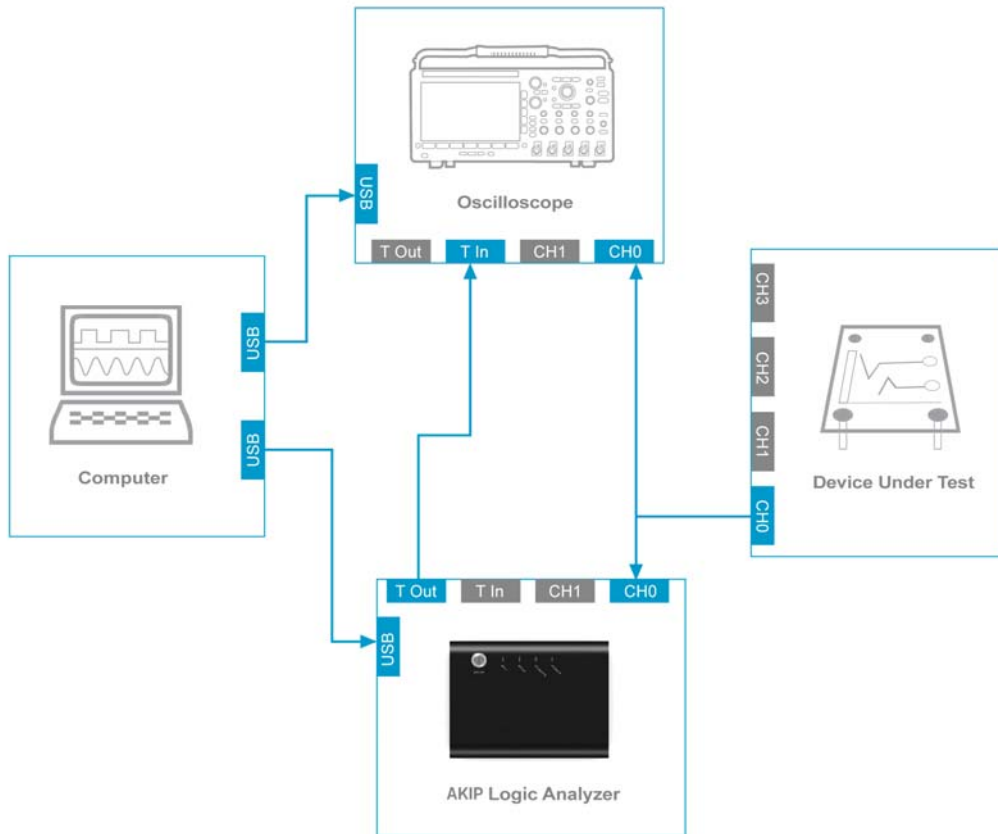

(2) Slave-Host

a) DSO is the Host, LA is the Slave. Connect the Trigger Out of DSO with the Trigger In of LA, and the LA uses external trigger. When DSO has been triggered, it will inform LA to capture signal.

b) DSO is the Host, LA is the Slave. Connect the Trigger Out of DSO with any channel of LA(users can define), which occupies one channel. When DSO has been triggered, it will inform LA to capture signal.

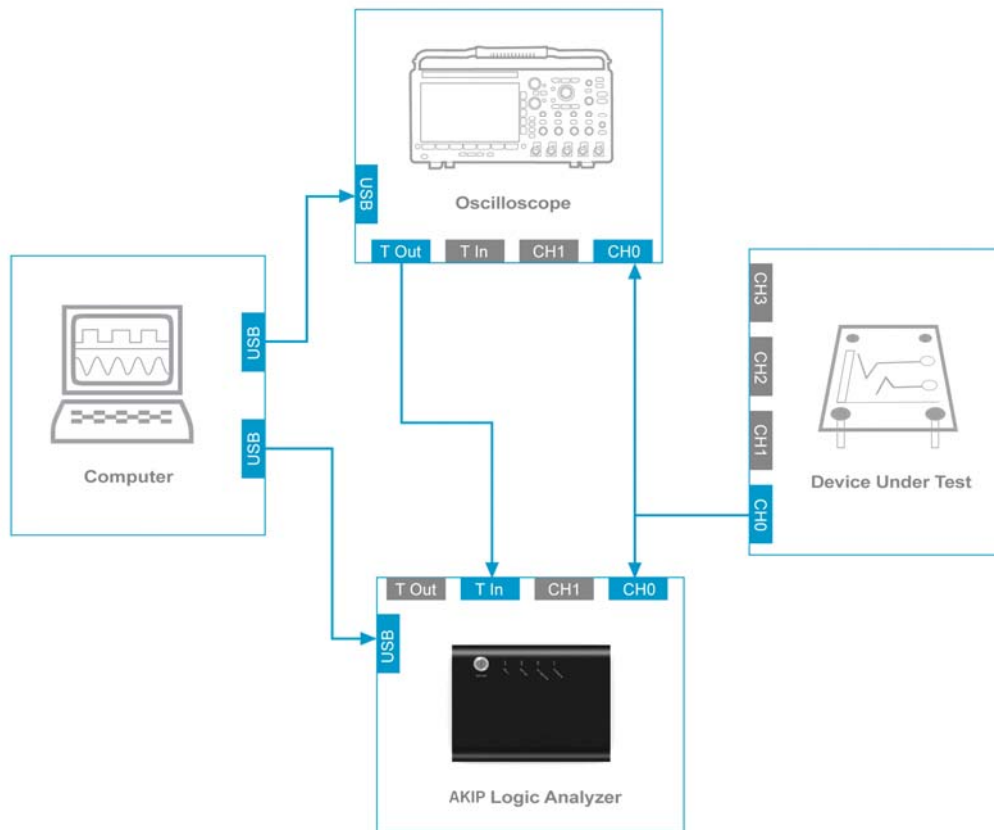

Operating Instructions

STEP 1. Confirm the DSO is connected correctly.

STEP 2. Click the Tool on the Menu Bar, then select DSO-stacked Settings to open the dialogue box.

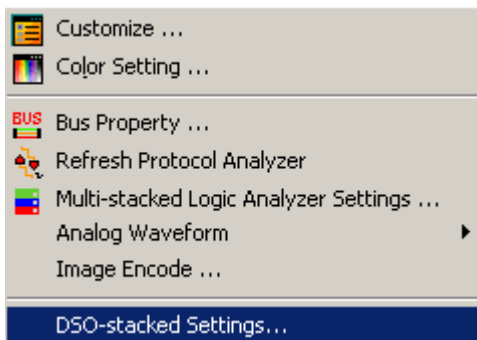

STEP 3. Set the Channel V/Div in the dialogue box.

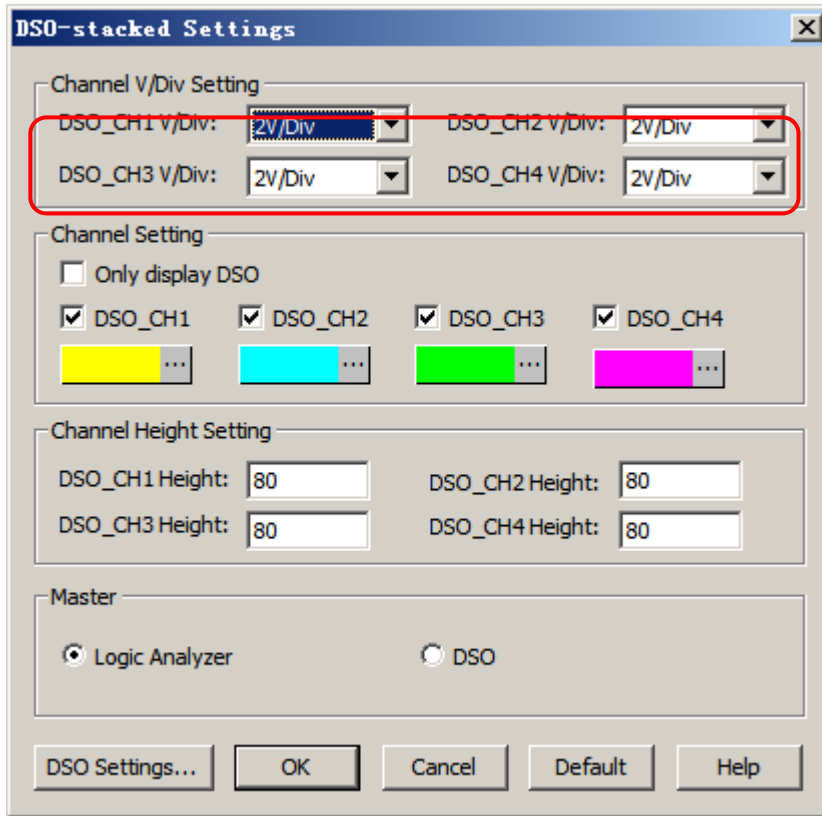

STEP 4. Set the Channel Waveform Color and select the DSO Channel to be displayed on LA software.

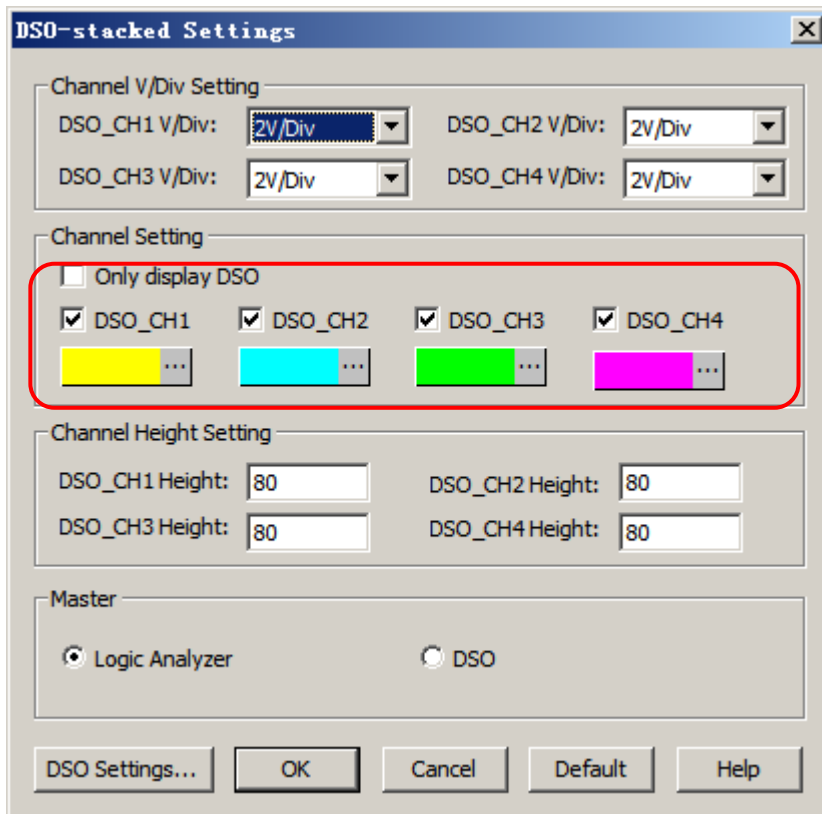

STEP 5. Select the Only Display DSO according to users' requirements.

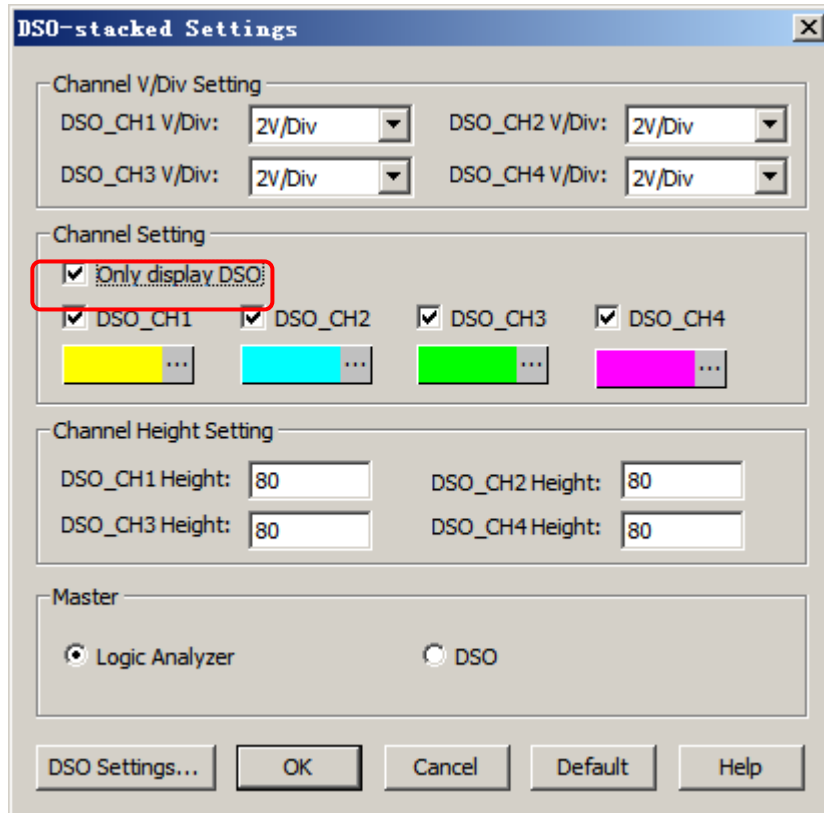

STEP 6. Set the Channel Height.

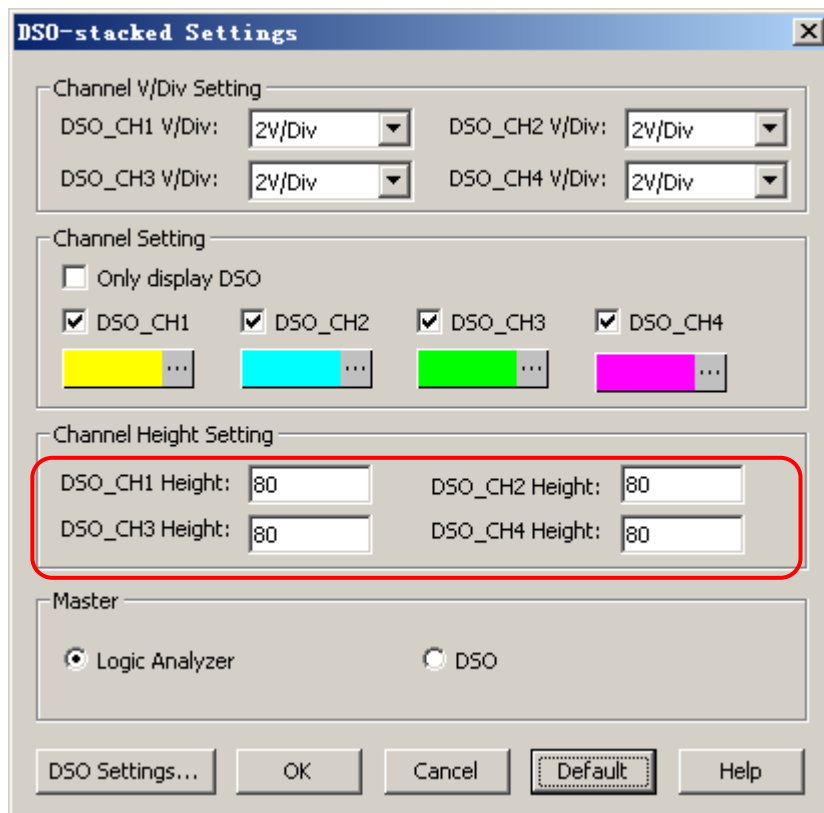

STEP 7. Set the Master to be LA or Oscilloscope according to the hardware usage mode.

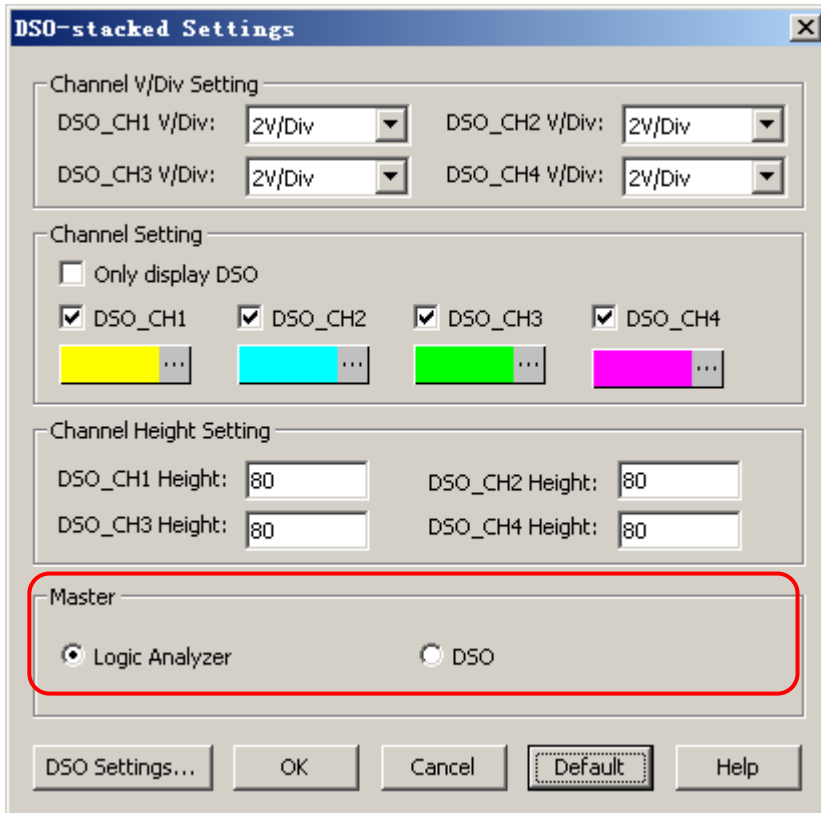

STEP 8. Press the DSO Settings button to open the dialogue box.

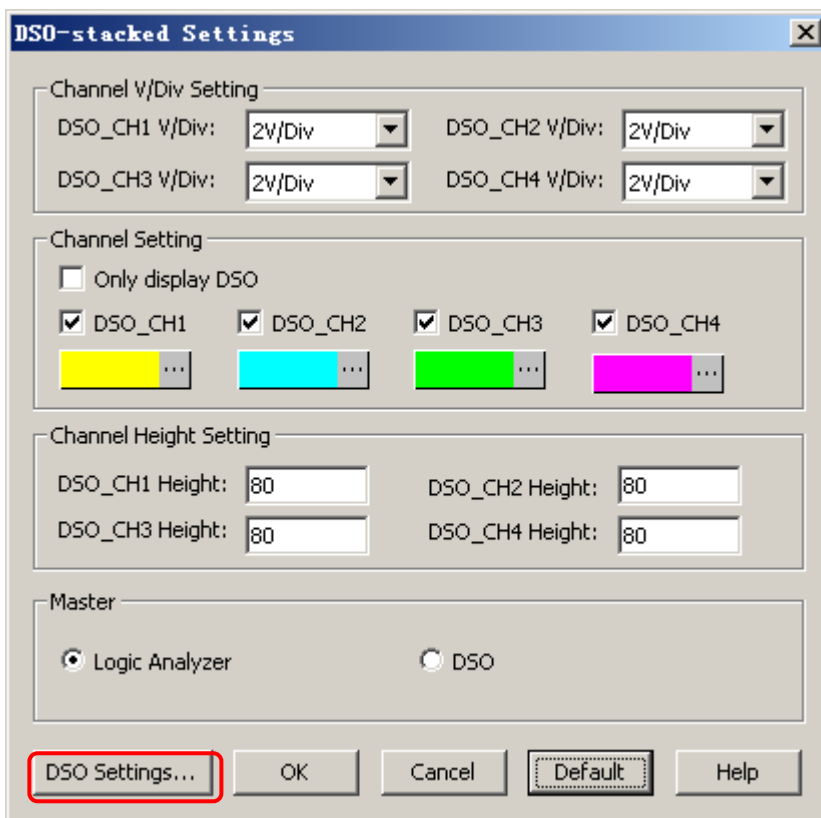

STEP 9. Select the connected DSO Manufacturer.

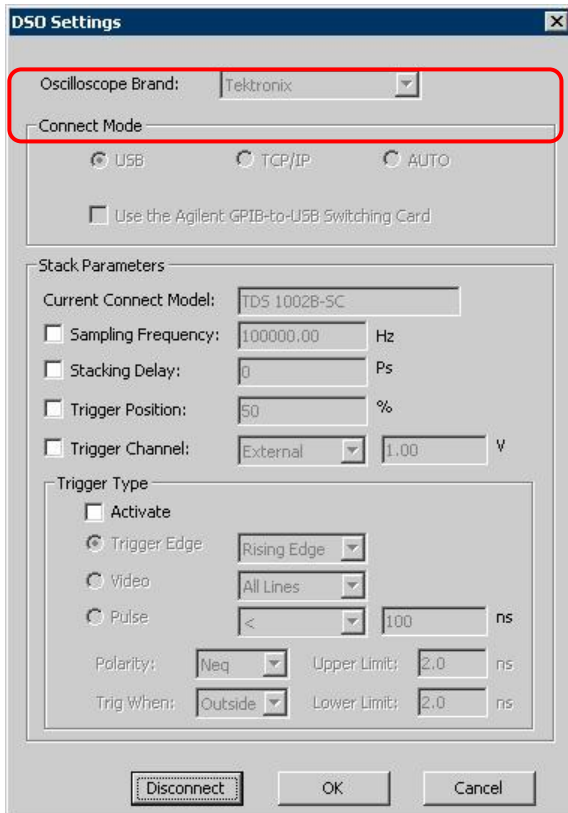

STEP 10. Set the Connection Mode to USB or TCP/IP according to the connection mode of DSO. If selecting TCP/IP, it is necessary to key in the IP Address of current computer. Users also can select AUTO to auto-recognize the connection mode.(Tektronix 1000,2000 series adopt the USB Interface to connect.)

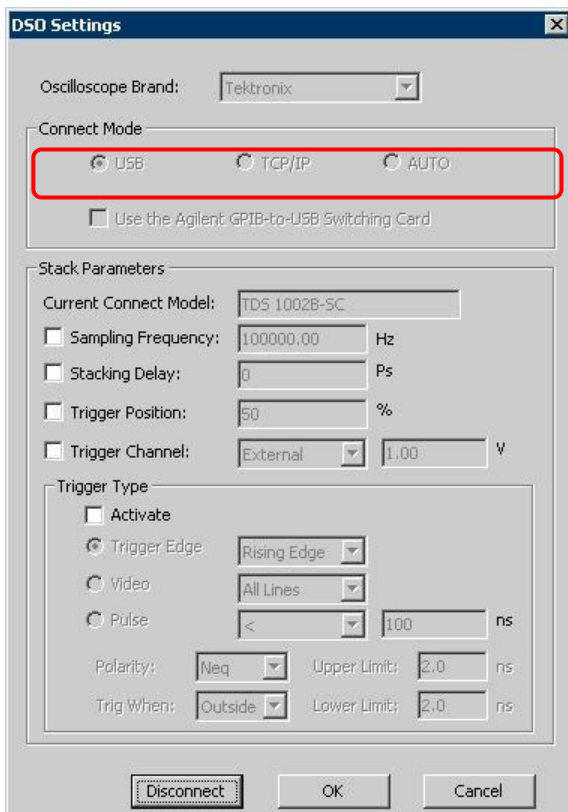

STEP 11. It will display the currently connected DSO Model after pressing the Connect button.

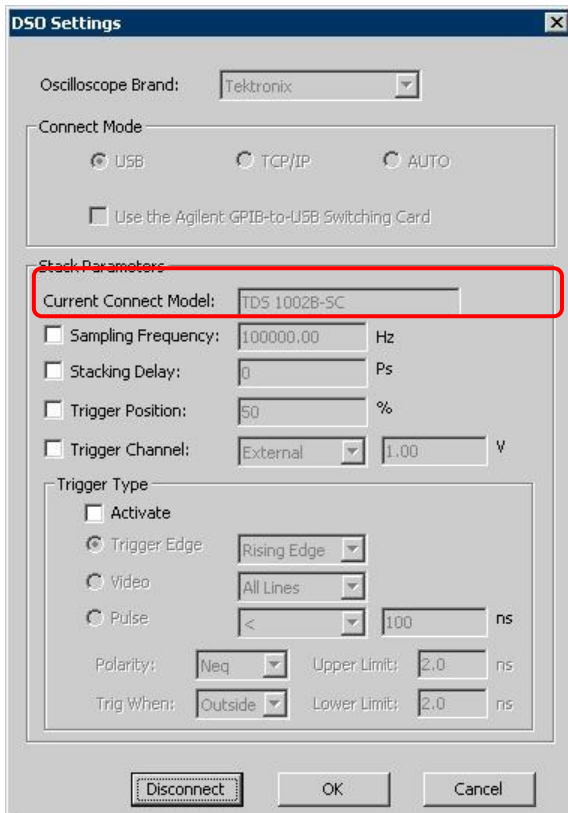

STEP 12. Set the relevant parameter and click the OK button.

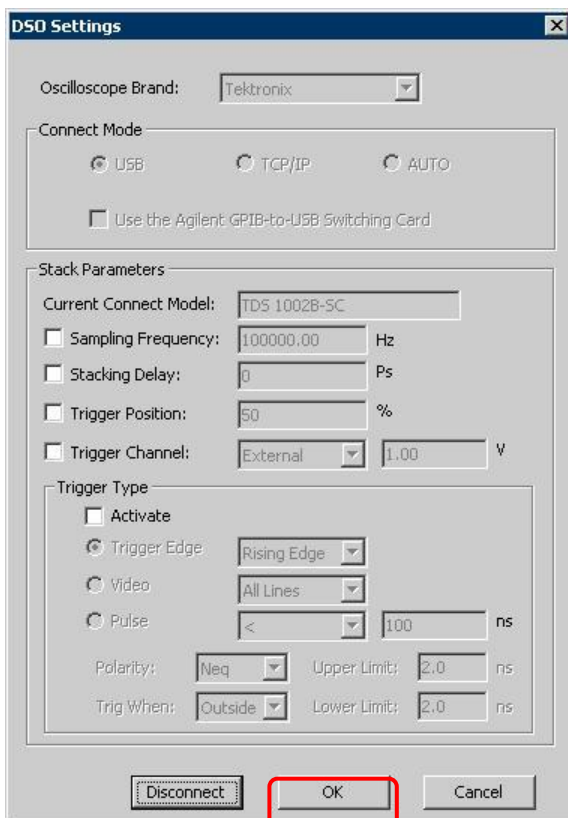

STEP 13. Select DSO_CH1 and DSO-CH2 channels to analyzer A0, A1 channels of LA. Below is the waveform it captured.

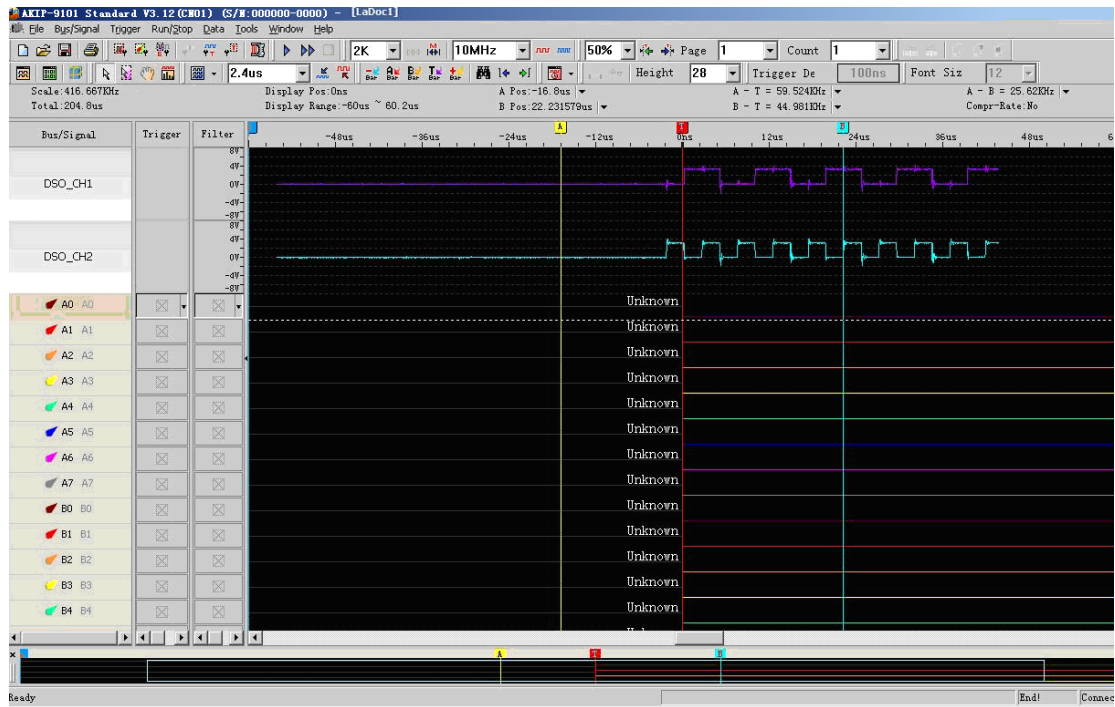

4.13 Memory Analyzer

Memory Analyzer enables the system to divide the packet format in the Protocol Analyzer and display the Address and Data in an independent list. It is better for understanding the relative relationship and status of the Address and Data in the operating process of the Protocol Analyzer. Users will know the operation when they use this function. It improves the efficiency of knowing the conditions.

4.13.1 Basic Software Setup of Memory Analyzer

STEP 1. Click **Tools** on the Menu Bar, then select  to activate the Memory Analyzer function.

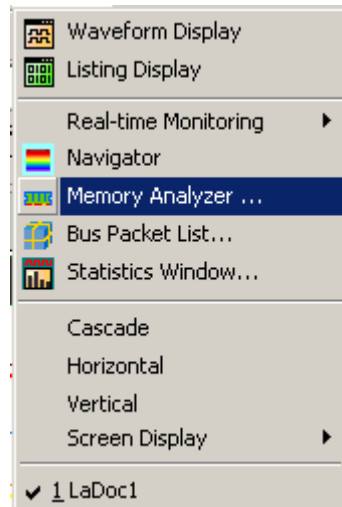

Fig4-163 - Memory Analyzer Interface

STEP 2. Open the Memory Analyzer dialog box.

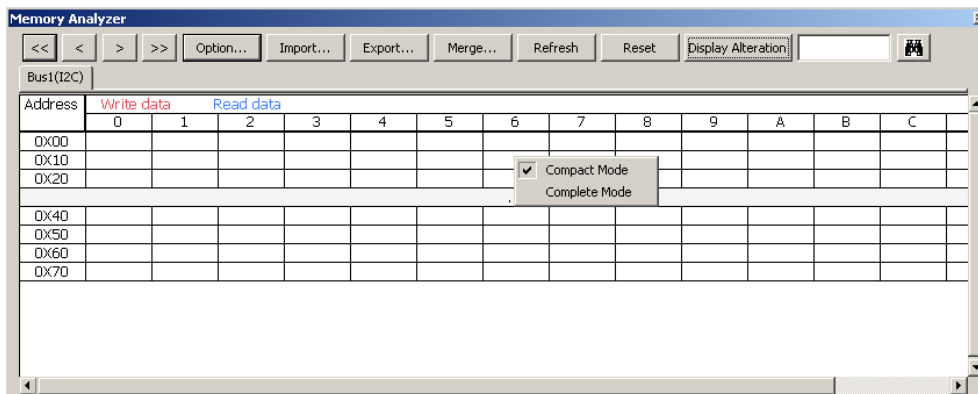

Fig4-164 - Memory Analyzer Dialog Box

1. Compact Mode and Complete Mode:

Click the Right Key in the memory analyzer dialog box; there are two modes for selecting, which are the Compact Mode and the Complete Mode. See the two different figures:

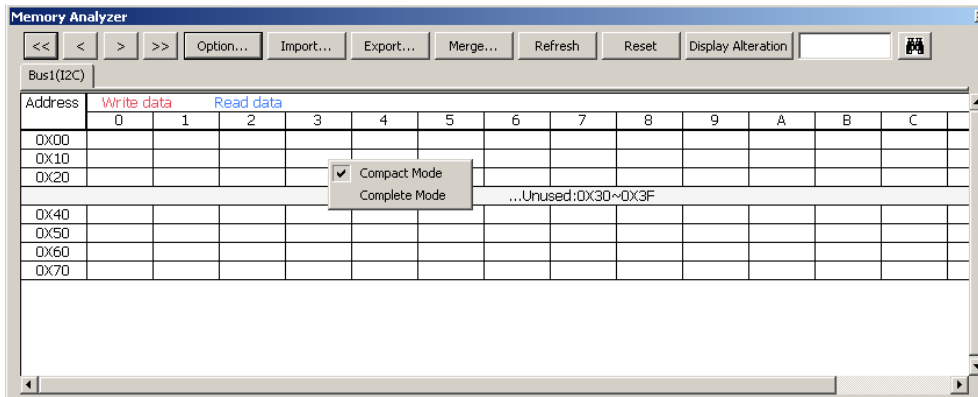

Fig 4-165 - Compact Mode

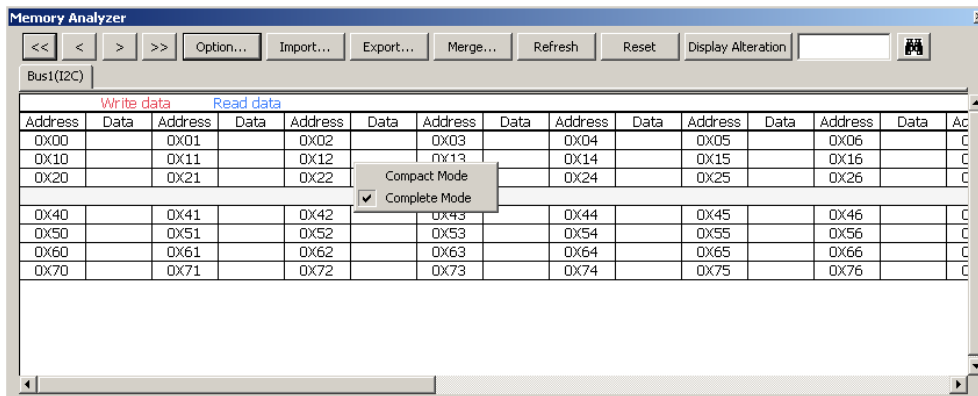





Fig 4-166 - Complete Mode

2. **Buttons:**

: It is used to find the first packet.

: It is used to find the previous packet.

: It is used to find the next packet.

: It is used to find the last packet.

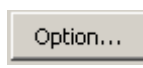
: It is used to set the relative parameters for the List Window of the Memory Analyzer; see

the following Option dialog box:

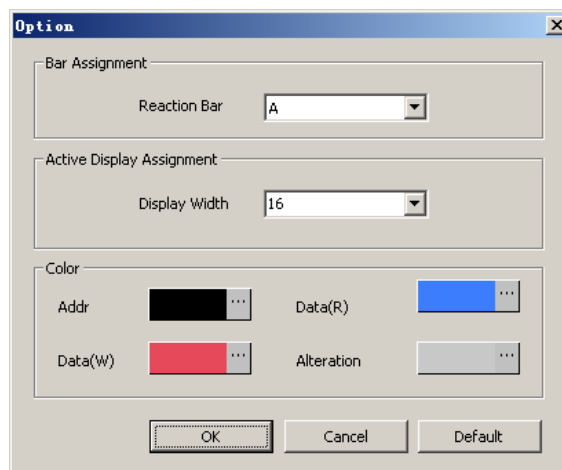

Fig4-167– Option Dialog Box

Reaction Bar: The default is the A Bar; the added Bar can be displayed and selected in the pull-down menu if users have added a new Bar. The data position of the Reaction Bar will be displayed in the List Window of the Memory Analyzer.

Note: The Ds/Dp Bar and T Bar can't be displayed in the pull-down menu.

Display Width: It is used to set the display width of the List Window of the Memory Analyzer; the default is 16. Users can select the 4, 8, 16 and 32 from the pull-down menu, and they also can input a value between 1 and 100.

Color: Users can vary the color of Addr, Data(R), Data(W) and Alteration as their requirements. The default color of the Addr is black; the default color of the Data(R) is blue; the default color of the Data(W) is red; and the default color of the Alteration is gray.



The Export function can select the TXT or EXCEL format to store the Data of the List Window of the Memory Analyzer; the Import function also can select the TXT or EXCEL formats to analyze the former export data.



It can merge with the different export files. See the Merge dialog box below.

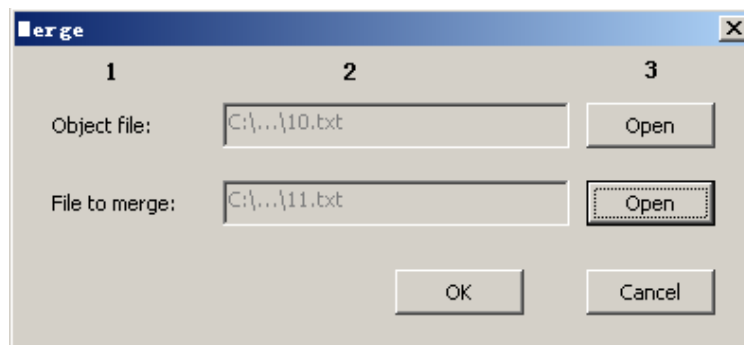

Fig4-168 – Merge Dialog Box

Object File:

1. It is the covered file, that is to say, it is a new file.
2. It can display the path of the “Object File” and the file name.
3. It can open the “Object File” by clicking the “Open” option.

File to merge:

1. It can create the new file with the object file.
2. It can display the path of the “File to merge” and the file name.
3. It can open the “File to merge” by clicking the “Open” option.

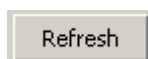

Pressing this button can refresh the data status of each Address data when there are some alterations in the Bus Data



The data status of each Address will be cleaned out and returned to the original status by pressing the button.

Display Alteration

: The Data in the List Window of the Memory Analyzer will be cleared by pressing this button and the List Window will display the alteration status of each cell. If the same Address has been written or read repetitively, the background of the cell will be gray and the list window will display the Data of the last packet. If the Address doesn't have any alteration, the Address Data will display the data of the Address without the background color. If it is the first time that the Address has been read, we confirm that the data of the packet has been altered.



: When users input the Address in this Edit Box and click the Find icon, it will go to the corresponding position which is highlighted by the Blue frame.

STEP 3 .Display the Memory Analyzer function in the waveform window.

Tip: The Packet is read; the Address is 0X6E; the Data are 0x25, 0x36, 0x47, 0x58, 0x69, 0x7A, 0x8B, 0x9C, 0xAD, 0xBE, 0xCF, 0xE0, 0xF1, 0x02 and 0x13 in sequence.

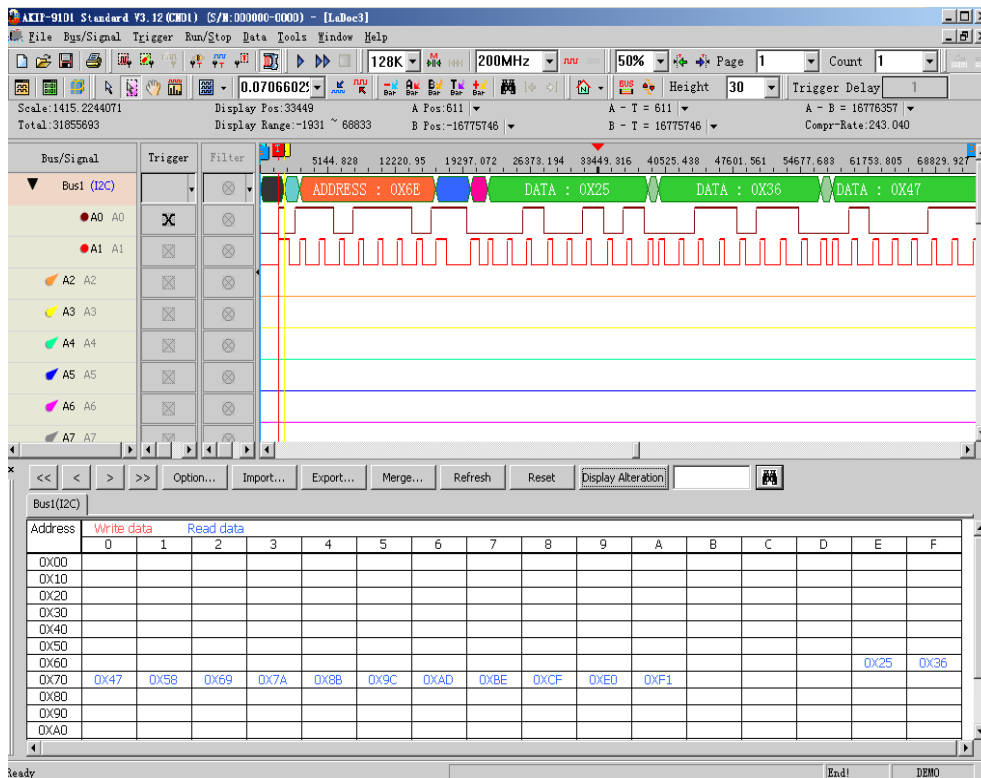

Fig4-169 – Memory Analyzer Display

5 Troubleshooting

- 5.1 Installation Troubleshooting
- 5.2 Software Troubleshooting
- 5.3 Hardware Troubleshooting

Objective

In this chapter, troubleshooting is divided into installation, software and hardware issues. These troubleshooting questions and answers depend not only on our engineers, but also on end users such as students, engineers, technical manual writers and others.

5.1 Installation Troubleshooting

Q1. Why it is not prompt when I insert the driver CD into my CD-ROM?

A: At this stage, the driver CD is not auto-executable. The primary issue here is a chipset problem. Though these six Logic Analyzer models seem only different in model number, they are quite different in firmware and chipsets. Due to installation procedures (see *Chapter 2*), we are unable to compile a driver program that auto-detects the chipset at the beginning of the installation.

Q2. Why does the installation software keep giving an error message saying that I don't have enough memory?

A: This kind of problem happens in many hardware installations. Turn off multimedia programs such as Media Player, media decoders, media encoders, and so on. If there are any multimedia icons in the system tray (see the far right end of the **START** menu taskbar), remove them. The Logic Analyzer software will run better in memory locations from 64 to 512MB.

Q3. What should I do if I want to share this software interface with all users of my computer after installing it?

A: The shortcut is removing the software interface, and then reinstalling it. By default, the program is available for all users.

Q4. My HDD is modest; which software components are absolutely necessary?

A: Choose **Custom** as your setup type. Next, unselect items such as examples and tutorials. You must install at least the Main App (application).

Q5. My MS Windows system will not accept the driver; what should I do?

A: Double check that you run the correct Setup.exe from the folder that corresponds to your hardware and MS Windows version. Visit our website for the latest updated or debugged software. If you are running this program on a virtual machine, the virtual machine may not support the amount of hardware addressing. In this case, try it with a machine that is physically running a Windows system.

5.2 Software Troubleshooting

Q1. Can I run the program even if I don't have the Logic Analyzer hardware?

A: Yes, you can. You can run the program under the demo mode. See. *Fig5-1*.

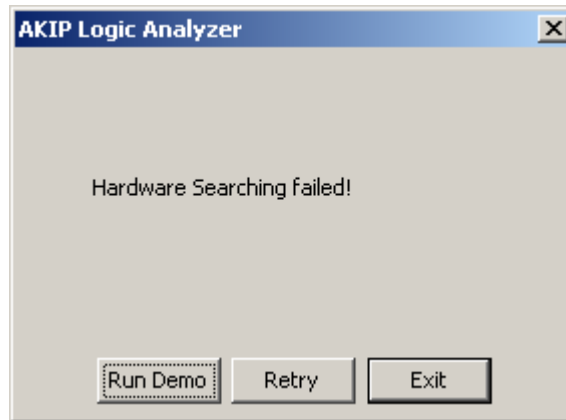

Fig. 5-1: Select **Run Demo** if you do not have the actual hardware.

Q2. I am running a graphing program and software at the same time. Whenever I try to make a screenshot of my work, it keeps telling me that I have insufficient memory space; what is wrong?

A: A few users have reported similar problems. We are not certain what causes it or how to fix it. However, we have found that if there is a defective address within 128MB to 512MB in your physical memory, your software might signal "End of memory". Thus, the program will warn you about insufficient memory. Test your memory with a varied memory testing program. Or, take a screenshot, close the program, paste it to the graphing program, and re-open the program.

Q3. A part of the background picture remains within the Waveform Display Area, especially when running the program in demo mode. What's wrong with it?

A: Your machine may have a memory management problem with either your physical RAM onboard or the RAM on your video card. Turn off any other multimedia or graphic programs and then re-run the software. If this does not work, restart your system. This should temporarily fix the problem. However, we highly recommend terminating all irrelevant programs while working with the Logic Analyzer (Try not to burn DVDs, not listen to music or watch movies while working with the Logic Analyzer.).

Q4. The default color setting of the Waveform Display Area is very cool, but I don't see anything when I print my work out with my black and white laser printer. What can I do?

A: Refer to *Section 3.6*; it should have clear, understandable instructions about changing the color of the user interface. See *Fig. 3-153*; this color setting should give a clear view of the Waveform Display Area, even with an old black and white laser printer.

5.3 Hardware Troubleshooting

Q1. Why are no lights on when I hook the USB cable to the Logic Analyzer?

A: Double check whether the other end is properly connected to your PC. There may also be a defect in your USB cable. Try another cable.

Q2. Why can't I read any signals from my Logic Analyzer?

A: Check whether you have correctly connected the signal cables to the activated pin on your test board and check the power supply of your test board. The Logic Analyzer does not supply any electricity to a test board via signal lines.

Q3. I get a signal from only one Logic Analyzer when I have two connected; what is wrong?

A: Currently, only the AKIP-9102, AKIP-9103, AKIP-9103/1 support many Logic Analyzers working in series. Also, make sure that the signal lines, power lines, and ground line are properly connected. Refer to Fig. 1-11, Table 1-2, Table 1-3, Table 1-4, and Table 1-5.

Q4. Why should I bother grounding? Where can I ground?

A: Grounding will protect the Logic Analyzer and the test board. A proper ground may improve the quality and accuracy of your data. Since it is impossible to avoid unwanted interference you may ground the Logic Analyzer with the test board to ensure that unwanted interference will equally disturb both the testing and tested devices, ensuring a set of data that is still accurate.

Conclusion

Every user of a product is a potential writer for *Chapters 5~7* in this User Manual. In fact, this chapter is a composition of many unnamed electronic professionals, especially experts.

6 FAQ

- 6.1 Hardware
- 6.2 Software
- 6.3 Registration
- 6.4 Technical Information
- 6.5 Others

Objective

In this chapter, common problems and questions are roughly classified into five categories: Hardware, Software, Registration, Technical Information, and Others. This is a backup resource for users, especially those without Internet access. Most references refer to English web links.

6.1 Hardware

H01. Is it ok to substitute stock items for bundled cables and connectors?

A: Yes, users may use any compatible connectors and cables. However, to ensure consistency and accuracy in measurements and data, we strongly recommend using the bundled connectors and cables. Each of the Logic Analyzer's is calibrated with the bundled cables and connectors before packing.

H02. Does AKIP manufacture grippers? How may I purchase grippers?

A: Yes, we have a production line dedicated to grippers. Contact our sales department and a sales representative will be happy to assist you.

H03. Is the memory size fixed? If I just use one of the ports, can I expand the memory size?

A: The Logic Analyzer's memory is fixed at 4 megabits. Due to current hardware limitations, the memory size cannot be modified, even as the number of ports used changes.

H04. Are different external sampling frequencies for different channels possible?

A: No, there is only one external sampling frequency available.

H05. Can I disable or set a certain port to *don't care* while during compression?

A: No, during compression, D Port will be set to be **disabled**.

H06. Why does the Logic Analyzer feature negative voltage calibration?

A: This allows users to analyze any given signal.

H07. How do I adjust the Trigger Level?

A: The adjustment of the trigger level is done with a port which consists of 8 channels. The trigger lever can only be adjusted for an entire port.

H08. Does the Logic Analyzer use hardware or software compression technology?

A: For time efficiency, the Logic Analyzer uses hardware compression.

H09. Is planning an Analyzer that can handle more channels?

A: Yes, we are working in this direction.

H10. Does the memory page vary when the depth of the memory changes?

A: Yes, the depth of memory changes the memory page.

H11. Is the Logic Analyzer expandable? How may I expand it?

A: Yes, the Logic Analyzer is expandable. At this stage, you can expand it with external module devices.

H12. Why must I reinstall the driver every time I use a different Logic Analyzer?

A: Since each Logic Analyzer has unique serial numbers, you must reinstall the driver every time you change the Logic Analyzer.

H13. Why is there no data? Why does data sampling seem inconsistent?

A: The reasons are varied, but you may follow this checklist for troubleshooting:

- 1) Always check the USB connection between the Logic Analyzer and your PC.
- 2) We strongly recommend using USB ports in the rear panel of a PC; these ports usually have better voltage stabilities than front panel ports. However, if front panel USB ports are directly soldered to the main board, you can use them.
- 3) Make sure the Logic Analyzer is directly connected with the PC (without a USB hub).
- 4) Inconsistent data display may indicate voltage irregularities in the main board; examine capacitors on your main board or power supply.

- 5) If the problem is the power supply, we strongly recommend purchasing a power supply with a hardwired voltage transformer rather than a voltage regulator. For power supplies with the same output power, those built with hardwired voltage transformers are usually much heavier than those relying on voltage regulators.

H14. What are the time settings for “Setup” and “Hold”?

A: Setup Time: 0.05ns ~ 0.25ns; Hold Time: 0.02ns ~ 0.08ns.

Clock High requires a minimum of 0.31ns. **Clock Low** requires at least 0.47ns.

6.2 Software

SW01. Why is the compression function not enabled by default?

A: Mostly to avoid significant errors when testing signals with high variability, or measuring a certain channel for a long time period.

SW02. What is the purpose of the Compression function?

A: The Compression function measures signals that vary slightly over a long period.

SW03. Can I enable Trigger Page and Compression Function simultaneously?

A: Yes, you can.

SW04. When should I use the “Bar” function?

A: This function allows you to highlight a segment of a waveform so that you can have a closer view. Depending on the configuration of **Waveform Display Mode** under **Tools** → **Customize**, a more accurate numeric value of sampling site, time, or frequency difference will be calculated and displayed as shown in *Fig. 6-1*.

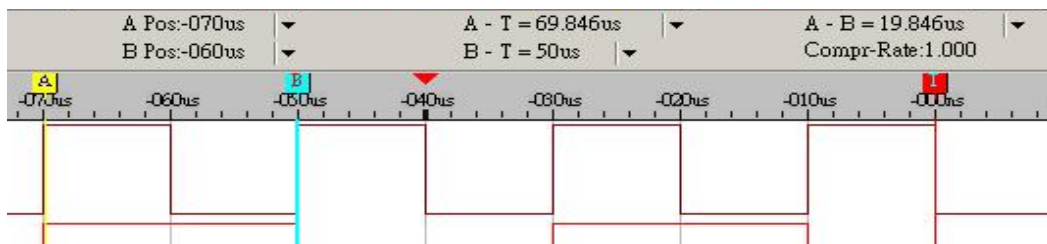

Fig. 6-1 – Bar Function

SW05. Can triggers be differentiated in Pre-Trigger and Post-Trigger?

A: Yes, they can.

SW06. Are all setup parameters and configurations saved as I save my work?

A: Yes, everything in your work space, except signal graph, will be saved.

SW07. What are the extremes for Delay Time and Clock & Trigger Delay Clock?

A: The interface will inform you of the interval you may use. However, it varies from case to case, depending on your test devices. See *Fig. 6-2*.

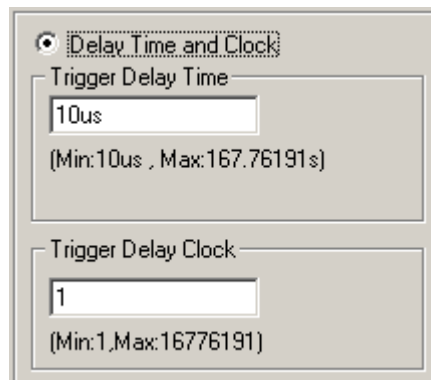

Fig. 6-2 – Delay Time and Clock

SW08. How do I know the version number of my software interface program?

A: Click **Help** from the menu (See *Fig 6-3*), and then select **About AKIP Logic Analyzer** (See *Figs 6-3 and 6-4*).

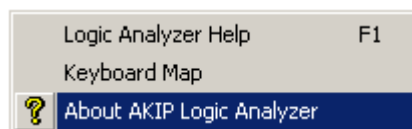

Fig. 6-3 – About AKIP Logic Analyzer



Fig. 6-4 - The circled information is the version number.

SW09. Can I save my signal data to a separate pure text file (*.txt)?

A: This feature is available in this version.

SW10. Why is the text display covered by other text or outside the display width?

A: At this stage, our software interface program has missing code for multilingual support. You will have to ensure your system default encoding is one of the following languages: 1) any English Encoding (en, en-XX), 2) Traditional Chinese (zh, zh-XX), 3) Simplified Chinese (zh, zh-CN in HZ, GB2312, GB18030). Double check the language configuration in **Regional and Language Options**.



Fig.6-5 – Windows Regional and Language Options

SW11. Is there a Reset that restores the default color settings for signal output waveforms in the Position Signal Display Area?

A: Yes, there is. Click **Tools** from the menu bar, and select **Color Setting**; click **Defaults**. However, this restores everything in this window. You must make a further adjustment if the color setting is the only thing you want to restore. See Fig. 6-6.

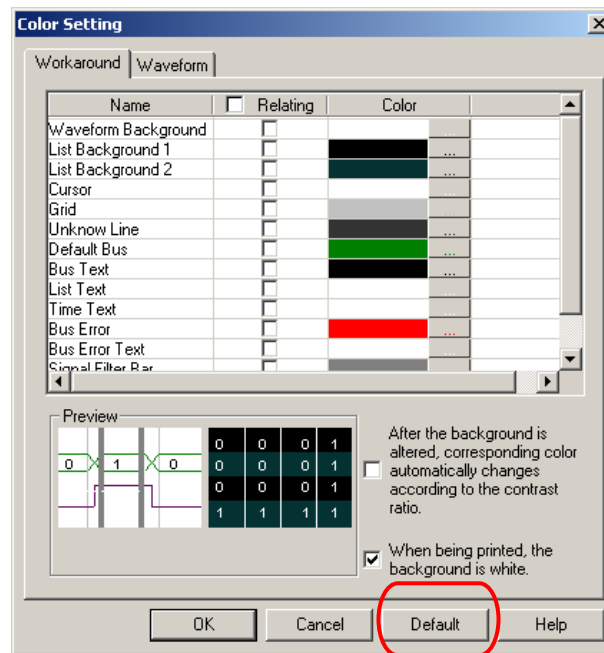

Fig. 6-6 – Restore Color Defaults

SW12. Can I change the displayed waveform mode?

A: Yes, you can. There are two ways to do this.

First, go through **Data → Waveform Mode** and choose a waveform. See Fig. 6-7.

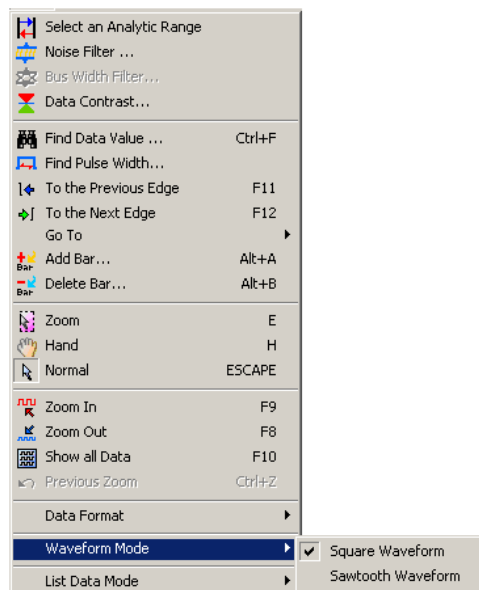

Fig. 6-7 – Waveform Mode

The second alternative is to right-click any place in the Waveform Display Area. Then, a menu will pop up. Click **Waveform Mode**, and choose a waveform. See Fig. 6-8.

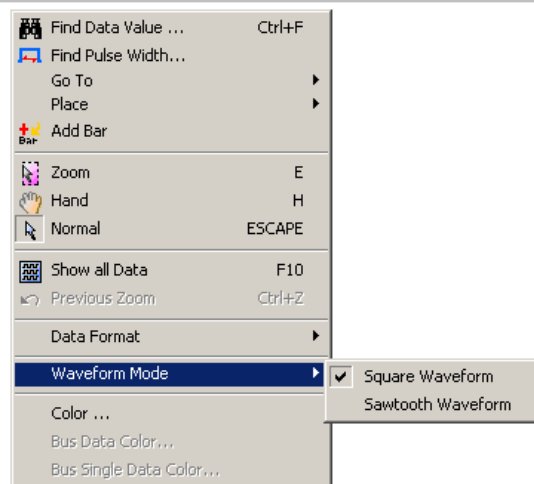

Fig.6-8 – Waveform Mode

SW13. Can I change the Signal Display Mode into the Timing Mode?

A: Yes, you can.

SW14. Why does not Filter Delay work when the Double Mode is enabled?

A: To optimize signal output quality and maximize memory efficiency, the **Signal Filter Setup** function may work under the Double Mode. However, the **Filter Delay** function doesn't work under the Double Mode at this stage.

6.3 Registration

RG01. What is the significance of the hardware serial number?

A: Every product is assigned and engraved with a unique serial number, which allows us to trace the original manufacturing date of a specific product.

RG02. How may I register if the purchasing date was more than one month ago?

A: In this case, fill in the registration card and send it via post, fax, or email to our customer service dept ,and a representative will process the registration for you.

RG03. What is the warranty length for my product?

A: A two-year FACTORY WARRANTY is offered in which you will have to send the defective product to the closest branch, an authorized service site, or our headquarters. The in-store warranty may vary, and many require extra charges for various extended warranty policies. The company is not being responsible for an in-store warranty that exceeds our factory warranty.

RG04. Why should I register this product?

A: If you do not register this product, the warranty will be counted from the manufacturing date indicated by the serial number of your product. Thus, we strongly recommend registering your product for your own benefit.

RG05. What should I do if the hardware serial number is previously registered?

A: In this case, take a picture of the decal on the rear side of the product and fill in the registration form. Call us and mail both picture and registration to us. A customer representative will be happy to assist you.

RG06. How do I register the protocol analyzer and buy protocols?

A: Every product is assigned and engraved with a unique serial number. please print your S/N number window as an example attachment and send it to our distributor or head office. According to your S/N, we will provide passwords for your protocol registration.

6.4 Technical Information

TI01. What is the Logic Analyzer?

A: The Logic Analyzer is a tool that sieves out and shows the digital signal from test equipment by using a clock pulse. The Logic Analyzer is like a digital oscilloscope. However, it only shows two voltage states (the logic status 1 and 0), differing from many voltage levels of an oscilloscope. The Analyzer has more channels than an oscilloscope to analyze the waveform. Since the Logic Analyzers obtains only signals 1 and 0, its sampling frequency is slower than an oscilloscope, which needs many voltage ranks. Moreover, the Logic Analyzer can receive many signals during a test.

TI02. How does the Logic Analyzer operate?

A: The Logic Analyzer reserves trigger requirement setting for users and uses them on the test equipment for the value of the sampling signals and puts them into the internal memory. The software of the Logic Analyzer will read out the value from the memory and switch it to the waveform or status shown for users' analysis.

TI03. What is the asynchronous Timing Mode?

A: Since the sampling clock and tested objects are not directly related to each other, and the former won't be controlled by the latter, the sampling clock and the tested signals will not be done at the same time. We call this "Timing Mode", which means that in the same time interval, you can get sampling data from the test equipment at one time, such as every 10 seconds. The internal clock, the Logic Analyzer's inner confirmed one, is often for sampling in Timing Mode as is the logic waveform.

TI04. What is the synchronous State Mode?

A: Because the sampling clock and measured object can be directly related, and are controlled by the latter, signals of the former and the latter can proceed simultaneously. We call this "State Mode". In this mode, the measured object provides the sampling clock. State Mode is when the Logic Analyzer can obtain sampling data from the test equipment synchronously. In other words, when the test equipment has a signal or signal group, this is the time to get the signal. For example, while the test equipment is sending out one rising edge, the Logic Analyzer can start to obtain one signal.

TI05. What are A-bar, B-bar and T-bar?

A: The T-bar, A-bar and B-bar are labels. T is the trigger label, which cannot be removed when the waveform or the state is displayed, which marks a pod. When searching for, or obtaining data, the A and B labels can be set in any location. Using the order of these markings, you can return quickly to the desired position to analyze data. This can also be a point to measure the interval between A-B, A-T or B-T.

TI06. What is a Trigger Gripper?

A: A gripper is the gathering point to collect the Logic Analyzer channels. When a cable connector is not suitable for the test device, a trigger gripper may be an alternative for connection.

TI07. What is a Channel?

A: The channel is the collection line of the input signal. Each channel is responsible for linking the pin of the measured device. Every channel is used to collect signals from the test equipment.

TI08. How can I display acquisition in the waveform captured by external sampling signal?

A: Select **Waveform Display** from the **Window** list.

TI09. What is an External Trigger?

A: An external trigger is a signal outside the Logic Analyzer. It is used for the simultaneous test of 2 test tools. For example, one Logic Analyzer can be started by one signal from another test tool. Or when it is triggered, it can output one signal to another test tool. The Logic Analyzer is often used for triggering an oscilloscope.

TI10. Why does Double Mode not coincide with Filter Delay?

A: In order to set out the perfect waveform from the Logic Analyzer and achieve optimal memory efficiency, you can use the **Signal Filter** when using **Double Mode**; the system doesn't support the function of **Filter Delay**.

6.5 Others

OT01. How was the Logic Analyzer developed?

A: It took us more than two years to develop this product. We envision "Everyone carrying the Logic Analyzer," and we would like to make some contributions to the electronics industry in return. We also wish to transform the stereotypical OEM factory into a world class R&D center.

OT02. What was the original intention of developing this item?

A: Originally, the Logic Analyzer was just for use by our engineering department. Later on, we saw the greater need for this kind of device. We made numerous enhancements and made it available to the public.

Conclusion

This chapter is full of hard facts for engineers. The contents of this version of the User Manual may look more different than the one on the web. Every engineer finds new problems, new solutions, or other issues, during real life applications. Though there are dozens of questions here, we look forward to your feedback, which is important for future versions. It may help us produce more efficient and accurate devices so that we will offer you much better service.

7 Appendix

7.1 Hot Keys

Objective

In this chapter, users will learn the functions of all defined hot keys in the software interface of the Logic Analyzer.

7.1 Hot Keys

Table 7-1: Hot Keys (1)

Hot Key	Equivalent Orders	Statement
A	Go to A Bar	Move the A-bar to the center of the waveform area; select A-bar by the cursor.
B	Go to B Bar	Move the B-bar to the center of the waveform area; select B-bar by the cursor.
T	Go to T Bar	Move the T-bar to the center of the waveform area; select T-bar by the cursor.
E	Change to Zoom mode	Change the mouse mode to Zoom
H	Change to Hand mode	Change the mouse mode to Hand.

Table 7-2: Hot Keys (2)

Hot Key	Equivalent Orders	Statement
Ctrl + A	Go to A Bar	Center A-bar.
Ctrl + B	Go to B Bar	Center B-bar.
Ctrl + C	File -> Capture Window	Open Capture Graph dialog box.
Ctrl + E	Data ->Zoom	Change Mouse mode to Zoom mode.
Ctrl + F	Data -> Find Data Value	Search specific data with predetermined conditions.
Ctrl + G	Bus/Signal -> Group into Bus	Group selected signals into a Bus.
Ctrl + N	File -> New	Create a new file.
Ctrl + O	File -> Open	Open a saved file.
Ctrl + P	File -> Print	Print an active file.
Ctrl + S	File-> Save	Save an active file with its current name, location and file format.
Ctrl + U	Bus/Signal -> Ungroup from Bus	Ungroup signals (Pins) from a Bus.
Ctrl + Z	Data -> Previous Zoom	Reverse the last zoom.
Ctrl + Shift + E	File->Export Waveform	Open Export Waveform dialog box.

Table 7-3: Hot Keys (3)

Hot Key	Equivalent Orders	Statement
Page Down	Operate the position shown	Go to next page of the data or the waveform
Page Up	Operate the position shown	Go to previous page of the data or the waveform
Home	Operate the position shown	Go to the beginning of the data or the waveform
End	Operate the position shown	Go to the end of the data or the waveform.
Up	Operate the position shown	Move the cursor up a grid.
Down	Operate the position shown	Move the cursor down a grid.
Left	Operate the position shown	Move the selected Bar or display left to prior the waveform or data.
Right	Operate the position shown	Move the selected Bar or display right to posterior the waveform or data.
ESC	Operate the position shown	Release all selected bars, and change Mouse mode to Normal.
Space	Change the trigger conditions	Change trigger conditions.

Table 7-4 : Hot Keys (4)

Hot Key	Equivalent Orders	Statement
F1	Help -> Logic Analyzer Help	Logic Analyzer Help
F2	Decrease the sampling rate	Decrease the sampling rate
F3	Increase the sampling rate	Increase sampling rate
F5	Run/Stop -> Single Run	Execute the acquirement once
F6	Run/Stop -> Repetitive Run	Execute the acquirement continuously
F7	Run/Stop -> Stop	Stop acquiring data
F8	Data -> Zoom Out	Zoom out the waveform
F9	Data -> Zoom In	Zoom in the waveform
F11	Data ->To the Previous Edge	Move forward to the prior variation waveform and center that location.
F12	Data -> To the Next Edge	Move forward to the next variation waveform and center that location.

Conclusion

The demonstrations in this User Manual will enhance users' understanding of our products in future issues, even though the manual ends here. We thank you for choosing the Logic Analyzer. Please contact us if you find anything that could be done better, either in software or hardware. We appreciate your feedback.