



AN90008

Recommendations for Printed Circuit Board assembly of DSN0402B-2 (SOD992B)

Rev. 1.0 — 11 July 2019

application note

Document information

Information	Content
Keywords	DSN0402B-2, SOD992B, 01005 package size, reflow soldering, surface mount, solder paste, stencil aperture, PCB, SMD, footprint, landing pattern, pick and place, Chip Scale Package, CSP
Abstract	This application note provides guidelines for board assembly of the ultra-small DSN0402B-2 (0.43 x 0.23 mm ²) chip scale package. The main focus is on recommendations for reflow soldering. For general information about footprint design and reflow soldering see application note AN10365 (Surface mount reflow soldering description).

1. Introduction

Due to the trend of reduced dimensions and increased density of functionality in smart phones and other mobile devices, there is an increasing request from the industry for extremely small components. With the new DSN0402B-2 (SOD992B) package which has a size of only 0.43 mm x 0.23 mm x 0.12 mm (01005), Nexperia offers an ultra-small surface mount chip scale diode package to support this trend.

Due to the very small size of the component, Nexperia investigated the board assembly process intensively in order to offer board mounting recommendations.

This includes printed circuit board (PCB) mounting pads, stencil apertures, solder paste and board assembly process parameters.

Using the recommended dimensions for pads and stencil as described in this document will help to achieve:

- optimum stand up height
- minimum tilt
- minimum rotation
- good board assembly process performance
- optimum board level reliability:
The reliability tests for qualification of the DSN0402B-2 device have been executed on PCBs with the solder pads as recommended in this application note.

While this application note should help minimizing any unexpected failures, following the advice in this document is not a guarantee for a perfect SMT assembly result. The results may differ depending on the machine capability, ambient conditions, material, etc.

2. DSN0402B-2 (SOD992B) package details

The DSN0402B-2 (SOD992B) is a Discrete Silicon No Lead package (DSN). It features tin (Sn) plated metal contacts under the package (bottom terminations) similar to DFN style packages. The DSN style package allows 100% utilization of the package area for active silicon, offering a significant performance advantage per board area compared to products in plastic molded packages.

The new production technology of the DSN0402B-2 results in very accurate dimensions. The package comes with an extremely low overall height of 120 µm only.

Key features:

- Ultra-small and flat package (0.43 x 0.23 x 0.12 mm³)
- CSP package without side wall protection
- The package area is 55% of the DSN0603 (SOD962)
- Very low dimensional tolerances
- Sn plated contacts for soldering on PCB
- No package internal interconnects like wire bond or flip chip
This is beneficial to minimize impedance
- Polarity marking visible from top and bottom (not applied for symmetric bi-directional diodes)
enables optical polarity check by pick and place machines and on PCB

While this application note should help minimizing any unexpected failures, following the advice in this document is not a guarantee for a perfect SMT assembly result. The results may differ depending on the machine capability, ambient conditions, material, etc.

The visual appearance is shown in [Fig. 1](#). [Fig. 2](#) shows the package dimensions.

Recommendations for Printed Circuit Board assembly of DSN0402B-2 (SOD992B)

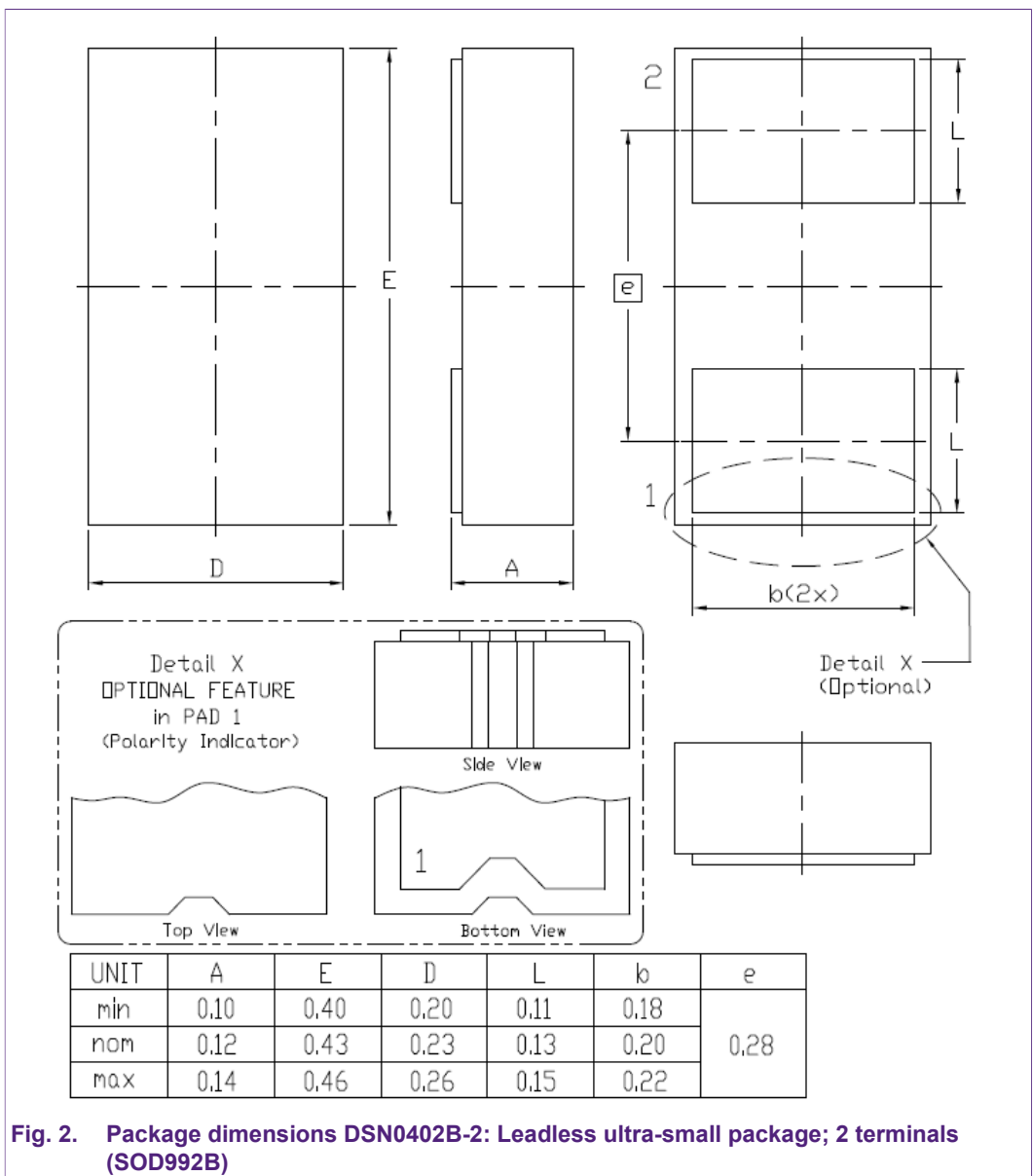

3. PCB solder pattern

3.1. Solder pad design general options

There are two types of solder pad / solder resist designs:

- Solder Mask Defined (SMD)
- Non-Solder Mask Defined (NSMD)

SMD is a method of designing the solder resist to partially overlap the Cu landing pattern on the PCB, whereas NSMD designs have a gap between the solder resist and the Cu landing pattern on the PCB. These two types are described in more detail in the next chapter.

3.1.1. Solder Mask Defined (SMD) pad versus Non-Solder Mask Defined (NSMD) pad

If the solder mask extends onto the solder lands, the remaining solderable area is solder mask defined (SMD). The “effective” solder pad is equal to the copper area that is not covered by the solder mask. This situation is illustrated in [Fig 3a](#) (left column). In case of a SMD pad, the copper will normally extend $75\ \mu\text{m}$ down to $50\ \mu\text{m}$ underneath the solder mask on all sides. In other words, the copper dimension is $0.1\ \text{mm}$ to $0.15\ \text{mm}$ larger than the solder mask dimension. These values may vary depending on the class of PCBs used. This allows for tolerances in copper etching and solder mask placement, during PCB production.

If the solder mask layer starts outside of the solder lands, and does not cover the copper, this is referred to as NSMD. The “effective” solder pad is equal to the copper area. In case of a NSMD, the solder mask should be at least $50\ \mu\text{m}$ away from the solder land on all sides. In other words, the solder mask dimension is $100\ \mu\text{m}$ larger than the copper dimension. These values may vary depending on the class of PCBs used. The main requirement is that the solder mask is sufficiently far away from the copper, such that – with the given tolerances in solder mask application – it does not extend onto the copper. A NSMD footprint is shown in [Fig 3b](#) (right column).

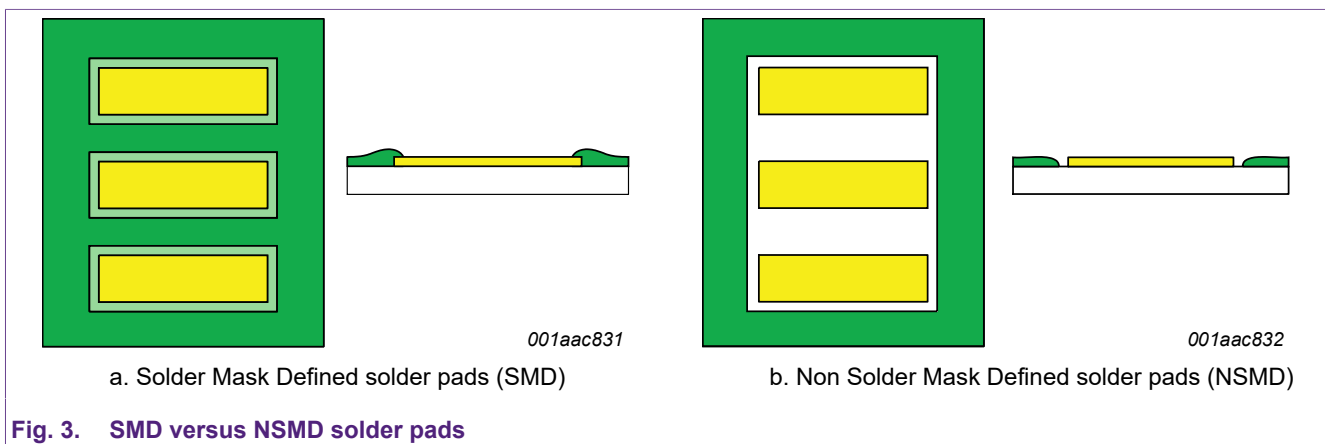

3.2. Solder pad design for DSN0402B-2 (SOD992B)

3.2.1. Recommended reflow solder footprint

Based on the small dimensions of DSN0402B-2 (01005) devices and the given tolerances for PCB manufacturing, it is recommended to use NSMD solder pads. Especially the gap between the Cu pads (with the PCB design tolerances) is with 150 μm small for a reasonable solder resist trace. In addition, such a resist trace would cause a higher tendency for tilting / rotation. Therefore, the recommended solder footprints are NSMD pads. Best soldering and reliability results have been achieved if the PCB solder pad size is same as device pad size and electrical connection of the pads is realized by micro-vias. The solder footprints with dimensions are shown in [Fig 4a](#). [Fig 4b](#) shows the solder footprints together with the package outline.

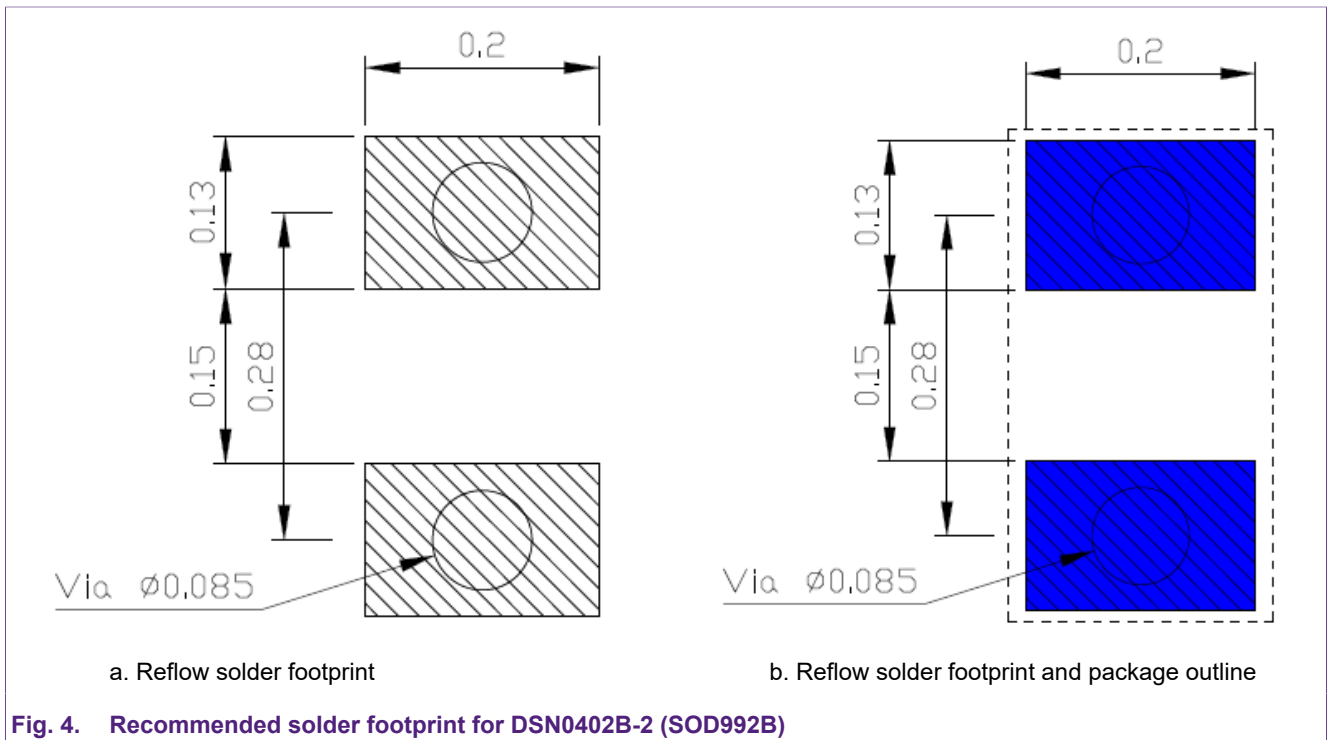

4. Solder stencil

4.1. Stencil recommendation

Due to small apertures and pad dimensions, a high-quality stencil should be used. E.g. for the Nexperia investigations, a stainless-steel stencil, manufactured by laser-cut and with plasma coating had been used. A nano-coated stencil has been investigated as well and is recommended to achieve best release performance at solder paste printing..

For the recommended Nexperia footprint (see chapter 3.2.1, [Fig. 4](#)), the optimum stencil aperture is of size $0.2 \times 0.13 \text{ mm}^2$. Based on stencil manufacturers' experience, rounded corners with a radius of 0.065 mm will result in best solder paste release during printing and in an adequate solder volume. For stencil apertures dimension, refer to [Fig. 5](#).

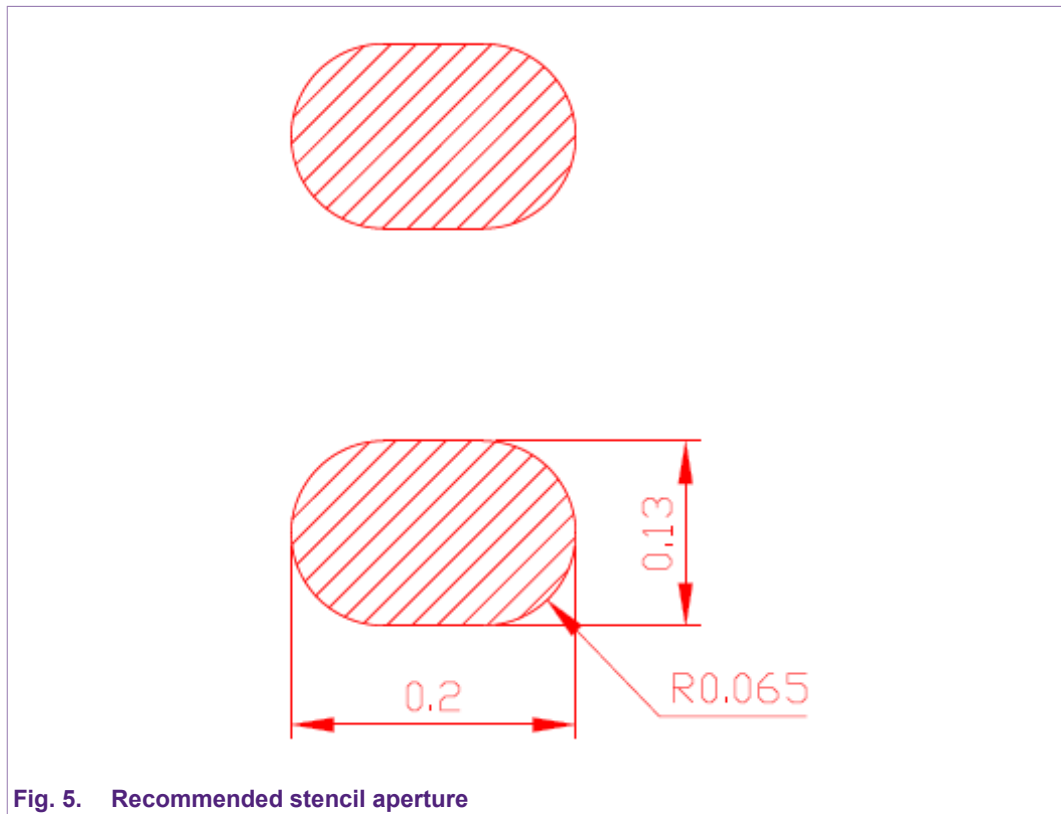

Fig. 5. Recommended stencil aperture

4.2. Stencil aperture design

Key design guidelines for stencil apertures are the area and aspect ratios. The area ratio for a common approach should be >0.66 . However, for ultra-small devices like DSN0402B-2, a smaller area ratio needs to be applied to achieve optimum assembling reliability. Smaller values are possible with adequate process control. Of course, it depends on the manufacturing environment and other requirements of the manufacturer.

The aspect ratio should be >1.5 which is less critical to fulfil. For an explanation of area ratio and aspect ratio, refer to [Fig 6](#).

Recommendations for Printed Circuit Board assembly of DSN0402B-2 (SOD992B)

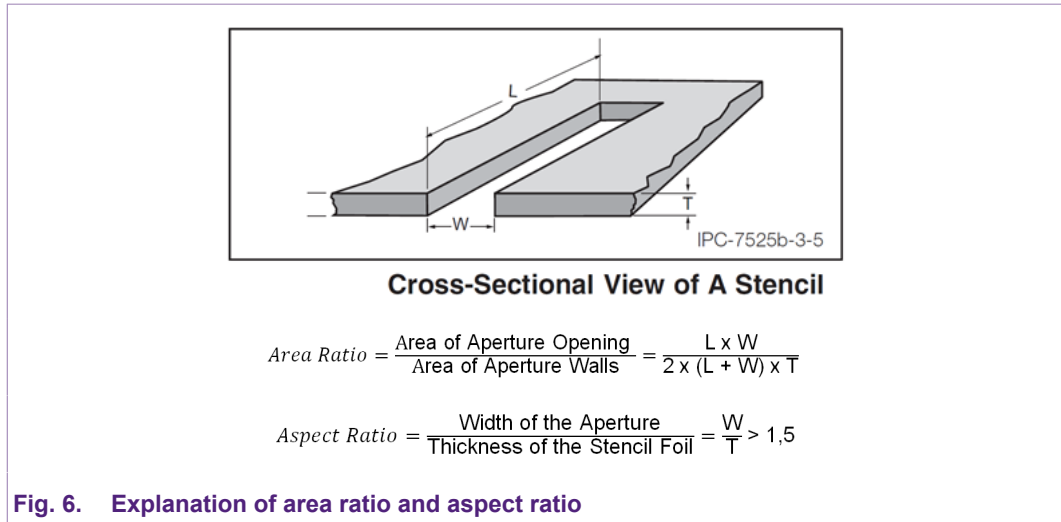

Table 1. Area and aspect ratio for recommended stencil aperture

Stencil thickness $T = 80\ \mu m$

	Aperture size	Area ratio	Aspect ratio
Nexperia recommended footprint	200 x 130 μm^2	0.51	1.63

Table 2. Area and aspect ratio consideration for 100 μm stencil thickness

Stencil thickness $T = 100\ \mu m$

	Aperture size	Area ratio	Aspect ratio
Nexperia recommended footprint	200 x 130 μm^2	0.41	1.3

[Table 1](#) shows the values for aspect and area ratio of the considered stencil apertures for a stencil thickness of 80 μm . It results in an area ratio of 0.51 for the Nexperia footprint recommendation. For such small area, the radius of the aperture ($r = 65\ \mu m$) has been considered for the calculation. In case of reduction to 75 μm stencil thickness, an area ratio of 0.54 with considering the 65 μm radius can be achieved for the Nexperia recommended stencil aperture. For such small solder footprint dimension an advanced process control is required.

In [Table 2](#), the values for aspect and area ratio for a 100 μm thick stencil are listed. The minimal footprints are surely not recommended any more for a 100 μm stencil thickness. The footprints may work in a tightly controlled process (e.g. with help of 3D solder print inspection). In addition to the stencil design guidelines, the potential device tilting also needs to be considered because of relatively high solder paste volumes and variation in printing

Nexperia does not recommend to use a stencil thickness > 80 μm

5. Solder paste

Besides stencil aperture and thickness, the solder paste used will have a significant impact on the printing and soldering performance. Solder pastes are available in different solder powder grain sizes. Refer to [Table 3](#).

Table 3. Survey of solder paste types (grain sizes)

Type	Less than 0.5%, larger than	10% max, between	80% max, between	10% max, less than
1	160	150 - 160	75 - 150	75
2	80	75 - 80	45 - 75	45
3	60	45 - 60	25 - 45	25
4	50	38 - 50	20 - 38	20
5	40	25 - 40	15 - 25	15
6	25	15 - 25	5 - 15	5
7	15	11 - 15	2 - 11	2

Solder paste type 4.5 and 5 were used for investigations with Nexperia solder pad and stencil aperture recommendation for the DSN0402B-2 (SOD992B) package with positive results. Using type 4 solder paste tends to result in unstable solder volumes. For a reduction of the stencil thickness to 60 μm it should be considered to use a type 6 solder paste.

6. Soldering process

For soldering of DSN0402B-2 packages, the following solder processes were considered:

- **Convection reflow under nitrogen atmosphere is clearly preferred**
- Convection reflow under air atmosphere also works, but:
 - Using an unfavorable layout results in DSN0402B-2 packages leaning towards undefined placement (tilting, rotating, misplacement) and in solder joints showing a tendency of increased voiding
 - Solder joint surfaces are rough, flux residues often become darker and the soldering behavior may deteriorate
- Vapor phase soldering is also possible

For investigation of reflow soldering a profile as recommended for SAC alloys by IPC-7095 was applied. The heat-up slope should be limited to max 3 °C/s for such small devices. Refer to [Fig. 7](#). For reflow profile definition the recommendation of solder paste data sheet should be considered as well.

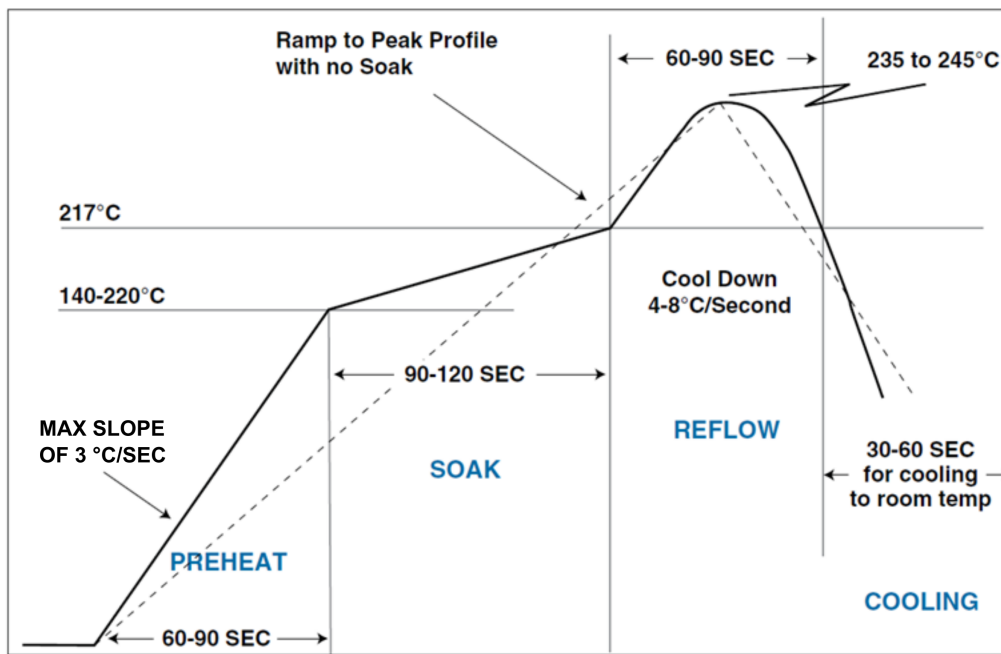

Source IPC-7095C

Remark: Heat-up slope should be limited to max. 3 °C/s for DSN0402 devices

Fig. 7. Reflow solder profile as applied for investigation

7. Handling recommendations

Besides the PCB and stencil design requirements, the ultra-small size of the DSN0402B-2 and as consequence the low weight of the component requires that some attention be paid to the pick and place (P&P) process. One effect which may cause problems during the pick and place (tape out) process is electrostatic charge. Nexperia has implemented preventive measures such as using a conductive plastic carrier tape (embossed tape) instead of a paper tape which is commonly used for passive 01005 components. Of course, the cover tape is also static dissipative. During extensive P&P trials, however, it was observed that a relative humidity below 30% in the production area leads to increased P&P (tape out) errors caused by electrostatic charging. Therefore, the environment should be controlled to >30% RH. In any case the feeders should be carefully connected to ground to avoid electrostatic charging.

Another observation is that feeders of some P&P suppliers require inserts or springs below the carrier tape. For embossed carrier tapes of such small components the inserts require a gap for the carrier tape pockets to achieve a smooth indexing without vibration. In this case, P&P machine suppliers should be contacted for recommendations.

It was found that it is beneficial for an optimum tape out yield if the cover tape peel off position is as close as possible to the pick-up position of the devices. That prevents any rotation of products due to mechanical movement and vibrations. A risk for rotation was still observed even the products covered by a metal plate after cover tape peel off.

Manual handling by tweezers (e.g. for PCB repair) is strictly not recommended. This would damage the package (CSP material is silicon).

8. Summary

8.1. Recommended solder footprint and stencil aperture

The recommended solder footprint including stencil aperture is shown in [Fig. 8](#).

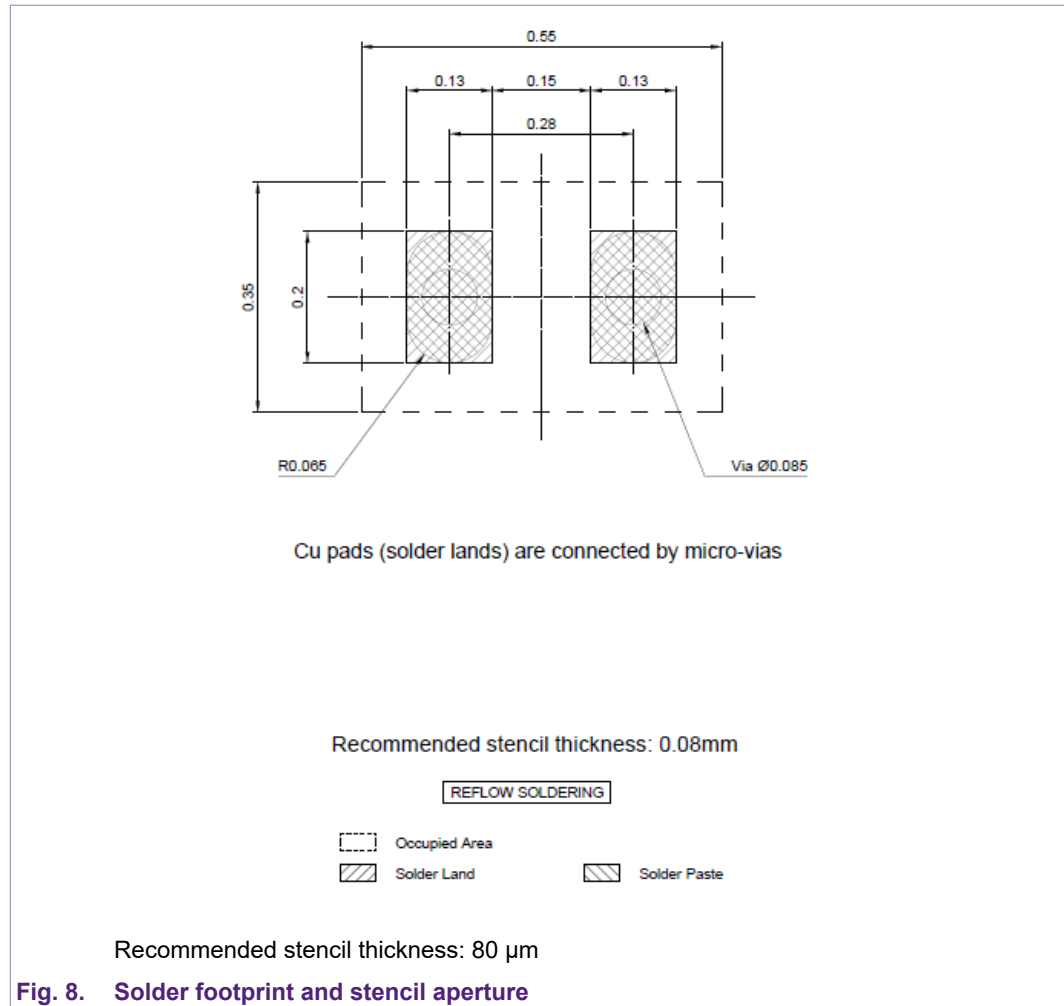

8.1.1. Real device on recommended solder footprint

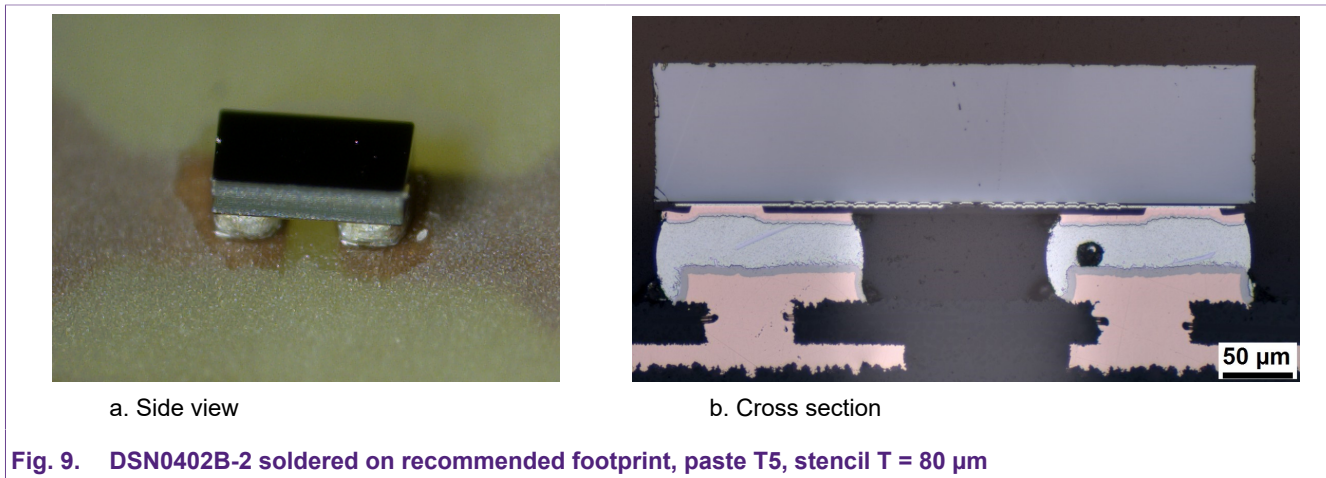

8.2. Further recommendations

8.2.1. Stencil layout and solder paste

- Stencil thickness of 80 µm in combination with Type 5 or 4.5 solder paste (refer to [Table 3](#)) is recommended
- A no-clean paste with a J-STD-004 classification “LO” is recommended
- Stencil thickness of 100 µm is clearly not recommended because:
 - The products tend to tilt due to the high amount of solder paste (see “Diode-Tilting”)
 - The amount of printed solder paste tends to vary more compared to thinner stencils which makes the printing process unstable
- A stencil aperture dimension as shown in [Fig. 5](#) and [Fig. 8](#) is recommended
- The combination of solder paste and PCB solder pad surface finish needs to be evaluated to achieve an optimized solder paste print result
- To get best printing (and soldering) results the cleaning cycle of the stencil should be well controlled
- A stainless-steel stencil, manufactured by laser-cut and with plasma coating should be used. Further print performance improvement by use of a nano-coated stencil.

8.2.2. Solder pad design

- NSMD pads with micro-via connection are recommended
- Conductor (Cu trace) between solder pads on PCB is not recommended
- Accuracy of PCB solder pad dimensions has significant impact on solder result. A tolerance of at least $\leq 10\%$ is recommended

Recommendations for Printed Circuit Board assembly of DSN0402B-2 (SOD992B)

8.2.3. Soldering process

- Convection reflow under nitrogen atmosphere is preferred
- Convection reflow under air atmosphere also works, but:
 - Using an unfavorable layout, products lean towards undefined tilting and rotation and solder joints show a tendency of increased voiding
 - Solder joint surfaces are rough, flux residues often become darker and the soldering behavior may deteriorate
- For ultra-small devices with two terminals like DSN0402B-2 the convection airflow in the reflow oven should be taken into account as it may cause tilting of devices.
- Vapor phase soldering is also possible

8.2.4. Handling recommendations

- Manual handling with tweezers (e.g. for repair) is not recommended
- Feeders of P&P machines: if inserts are required underneath the carrier tape, a gap in this insert for the carrier tape pocket should be implemented.
Some feeders require a spring underneath the carrier tape.
The cover tape peel-off position should be as close as possible to the device pick-up position.
A reduction of feeding speed can help to improve tape out yield.
Ask P&P machine supplier for further recommendations.
- Feeders should be carefully grounded to avoid electrostatic charging
- Relative humidity for P&P should be >30%
- The placement force of P&P machine should be 1N to 2N
- Keep control of thawing time of solder paste bundle to avoid too much humidity in paste
- Keep control of the time from solder paste printing until pick & place and reflow to avoid flux drying

9. Revision history

Table 4. Revision history

Revision number	Date	Description
1.0	2019-07-11	Initial version for DSN0402B-2, SOD992B

10. Legal information

Definitions

Draft — The document is a draft version only. The content is still under internal review and subject to formal approval, which may result in modifications or additions. Nexperia does not give any representations or warranties as to the accuracy or completeness of information included herein and shall have no liability for the consequences of use of such information.

Disclaimers

Limited warranty and liability — Information in this document is believed to be accurate and reliable. However, Nexperia does not give any representations or warranties, expressed or implied, as to the accuracy or completeness of such information and shall have no liability for the consequences of use of such information. Nexperia takes no responsibility for the content in this document if provided by an information source outside of Nexperia.

In no event shall Nexperia be liable for any indirect, incidental, punitive, special or consequential damages (including - without limitation - lost profits, lost savings, business interruption, costs related to the removal or replacement of any products or rework charges) whether or not such damages are based on tort (including negligence), warranty, breach of contract or any other legal theory.

Notwithstanding any damages that customer might incur for any reason whatsoever, Nexperia's aggregate and cumulative liability towards customer for the products described herein shall be limited in accordance with the Terms and conditions of commercial sale of Nexperia.

Right to make changes — Nexperia reserves the right to make changes to information published in this document, including without limitation specifications and product descriptions, at any time and without notice. This document supersedes and replaces all information supplied prior to the publication hereof.

Suitability for use — Nexperia products are not designed, authorized or warranted to be suitable for use in life support, life-critical or safety-critical systems or equipment, nor in applications where failure or malfunction of an Nexperia product can reasonably be expected to result in personal injury, death or severe property or environmental damage. Nexperia and its suppliers accept no liability for inclusion and/or use of Nexperia products in such equipment or applications and therefore such inclusion and/or use is at the customer's own risk.

Applications — Applications that are described herein for any of these products are for illustrative purposes only. Nexperia makes no representation or warranty that such applications will be suitable for the specified use without further testing or modification.

Customers are responsible for the design and operation of their applications and products using Nexperia products, and Nexperia accepts no liability for any assistance with applications or customer product design. It is customer's sole responsibility to determine whether the Nexperia product is suitable and fit for the customer's applications and products planned, as well as for the planned application and use of customer's third party customer(s). Customers should provide appropriate design and operating safeguards to minimize the risks associated with their applications and products.

Nexperia does not accept any liability related to any default, damage, costs or problem which is based on any weakness or default in the customer's applications or products, or the application or use by customer's third party customer(s). Customer is responsible for doing all necessary testing for the customer's applications and products using Nexperia products in order to avoid a default of the applications and the products or of the application or use by customer's third party customer(s). Nexperia does not accept any liability in this respect.

Export control — This document as well as the item(s) described herein may be subject to export control regulations. Export might require a prior authorization from competent authorities.

Translations — A non-English (translated) version of a document is for reference only. The English version shall prevail in case of any discrepancy between the translated and English versions.

Trademarks

Notice: All referenced brands, product names, service names and trademarks are the property of their respective owners.

List of Tables

Table 1. Area and aspect ratio for recommended stencil aperture.....7

Table 2. Area and aspect ratio consideration for 100 µm stencil thickness.....7

Table 3. Survey of solder paste types (grain sizes)..... 8

Table 4. Revision history..... 13

List of Figures

Fig. 1. DSN0402B-2 (SOD992B) visual appearance.....	3
Fig. 2. Package dimensions DSN0402B-2: Leadless ultra-small package; 2 terminals (SOD992B).....	3
Fig. 3. SMD versus NSMD solder pads.....	4
Fig. 4. Recommended solder footprint for DSN0402B-2 (SOD992B).....	5
Fig. 5. Recommended stencil aperture.....	6
Fig. 6. Explanation of area ratio and aspect ratio.....	7
Fig. 7. Reflow solder profile as applied for investigation.....	9
Fig. 8. Solder footprint and stencil aperture.....	11
Fig. 9. DSN0402B-2 soldered on recommended footprint, paste T5, stencil T = 80 μm	12

Contents

1. Introduction	2
2. DSN0402B-2 (SOD992B) package details	2
3. PCB solder pattern	4
3.1. Solder pad design general options.....	4
3.1.1. Solder Mask Defined (SMD) pad versus Non-Solder Mask Defined (NSMD) pad.....	4
3.2. Solder pad design for DSN0402B-2 (SOD992B).....	5
3.2.1. Recommended reflow solder footprint.....	5
4. Solder stencil	6
4.1. Stencil recommendation.....	6
4.2. Stencil aperture design.....	6
5. Solder paste	8
6. Soldering process	9
7. Handling recommendations	10
8. Summary	11
8.1. Recommended solder footprint and stencil aperture..	11
8.1.1. Real device on recommended solder footprint.....	12
8.2. Further recommendations.....	12
8.2.1. Stencil layout and solder paste.....	12
8.2.2. Solder pad design.....	12
8.2.3. Soldering process.....	13
8.2.4. Handling recommendations.....	13
9. Revision history	13
10. Legal information	14

© Nexperia B.V. 2019. All rights reserved

For more information, please visit: <http://www.nexperia.com>

For sales office addresses, please send an email to: salesaddresses@nexperia.com

Date of release: 11 July 2019
