



SOT1430-1

X2QFN10; Reel pack, SMD, 7"; Q1/T1 standard product orientation; Orderable part number ending ,471 or Z; Ordering code (12NC) ending 471

Rev. 2 — 25 October 2017

Packing information

1 Packing method

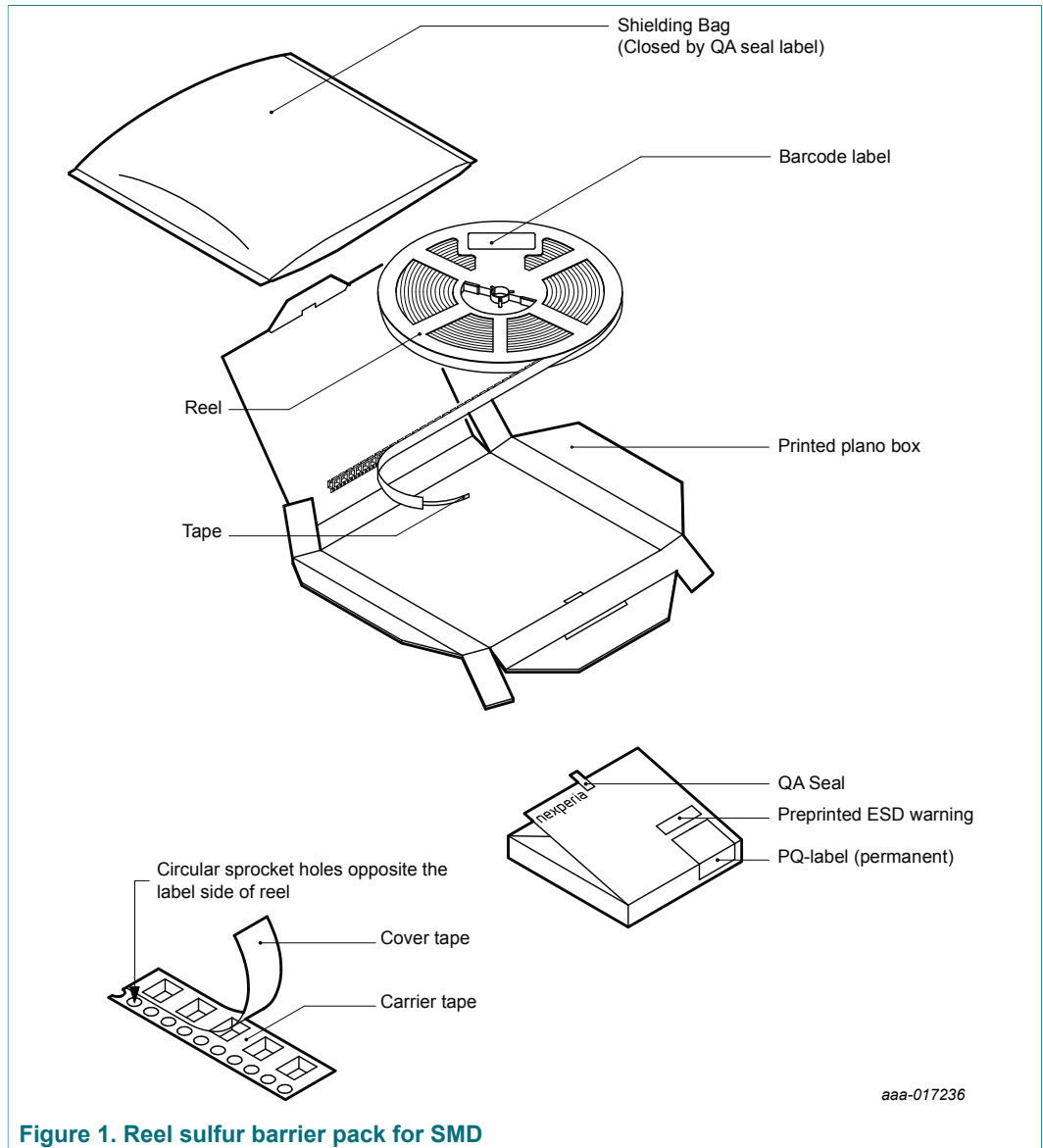

Figure 1. Reel sulfur barrier pack for SMD

X2QFN10; Reel pack, SMD, 7"; Q1/T1 standard product orientation; Orderable part number ending ,471 or Z; Ordering code (12NC) ending 471

Table 1. Dimensions and quantities

Reel dimensions d × w (mm) ^[1]	SPQ/PQ (pcs) ^[2]	Reels per box	Outer box dimensions l × w × h (mm)
180 × 8	5 000	1	192 × 188 × 27

[1] d = reel diameter; w = tape width.

[2] Packing quantity dependent on specific product type. Please contact your local Nexperia representative for ordering.

2 Product orientation

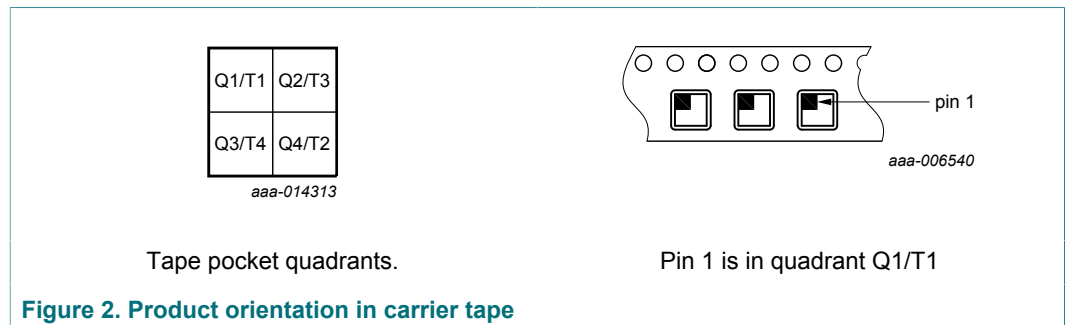

3 Carrier tape dimensions

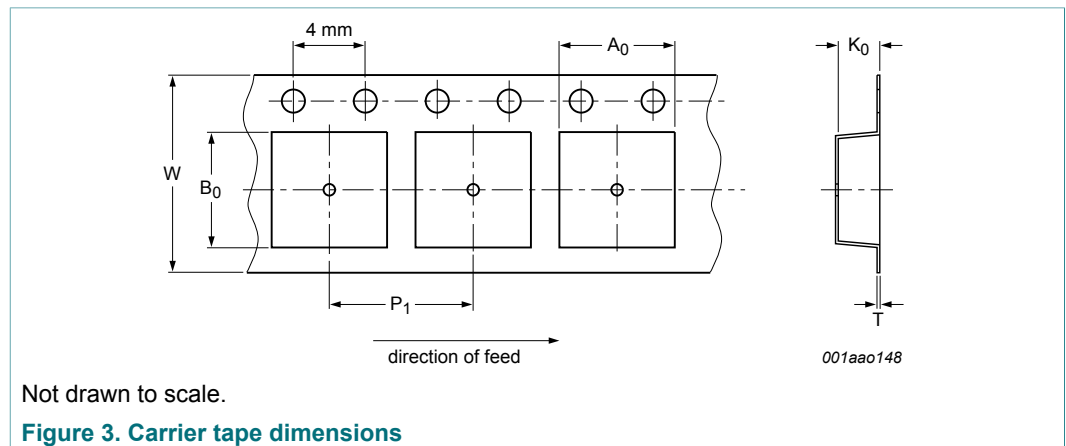

Table 2. Carrier tape dimensions

In accordance with IEC 60286-3.

A ₀ (mm)	B ₀ (mm)	K ₀ (mm)	T (mm)	P ₁ (mm)	W (mm)
1.60 ± 0.05	1.90 ± 0.05	0.45 ± 0.05	0.25 ± 0.05	4.0 ± 0.1	8.0 ± 0.1

4 Reel dimensions

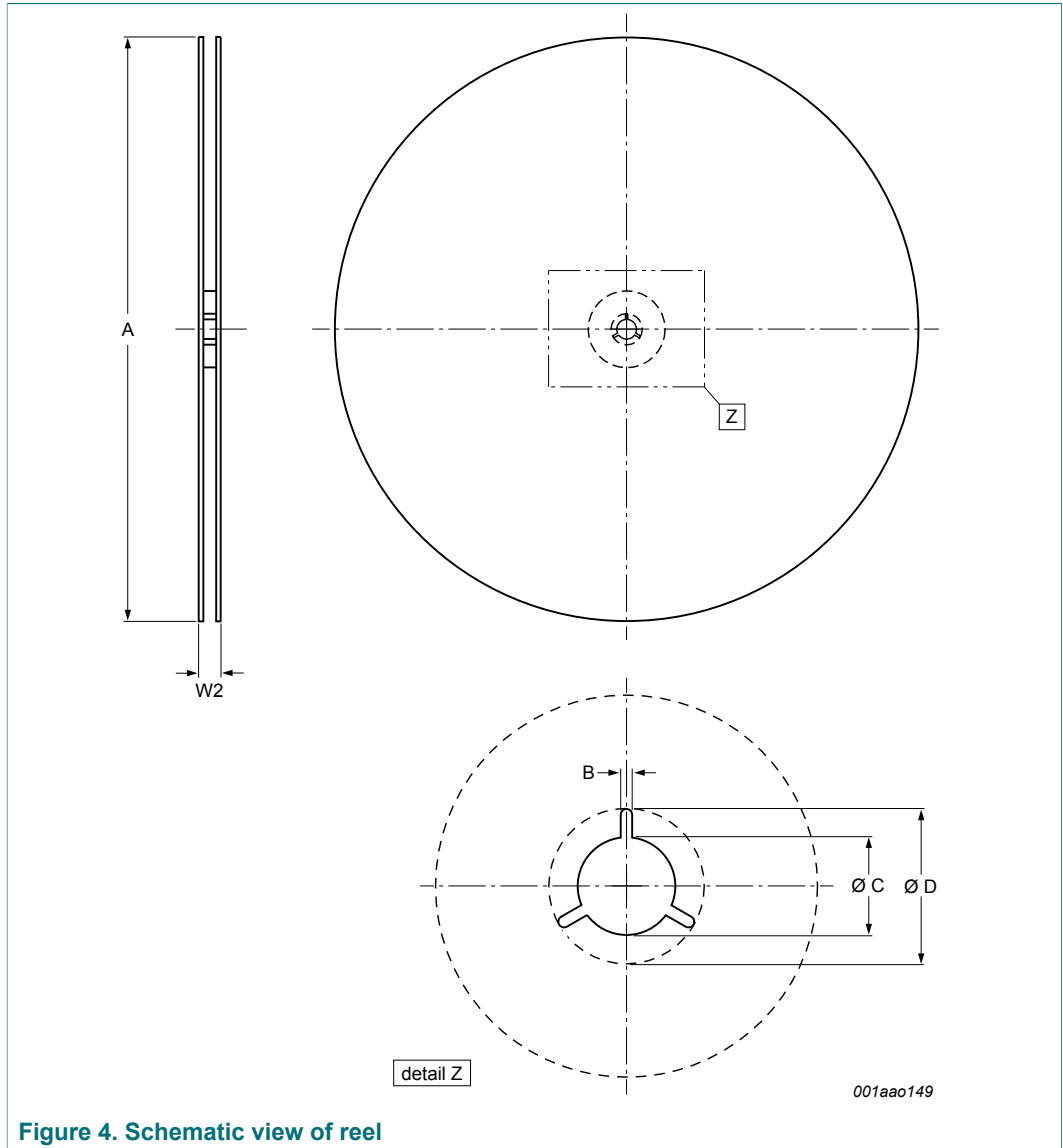

Figure 4. Schematic view of reel

Table 3. Reel dimensions
In accordance with IEC 60286-3.

A [nom] (mm)	W2 [max] (mm)	B [min] (mm)	C [min] (mm)	D [min] (mm)
180	14.4	1.5	12.8	20.2

X2QFN10; Reel pack, SMD, 7"; Q1/T1 standard product orientation; Orderable part number ending ,471 or Z; Ordering code (12NC) ending 471

5 Barcode label

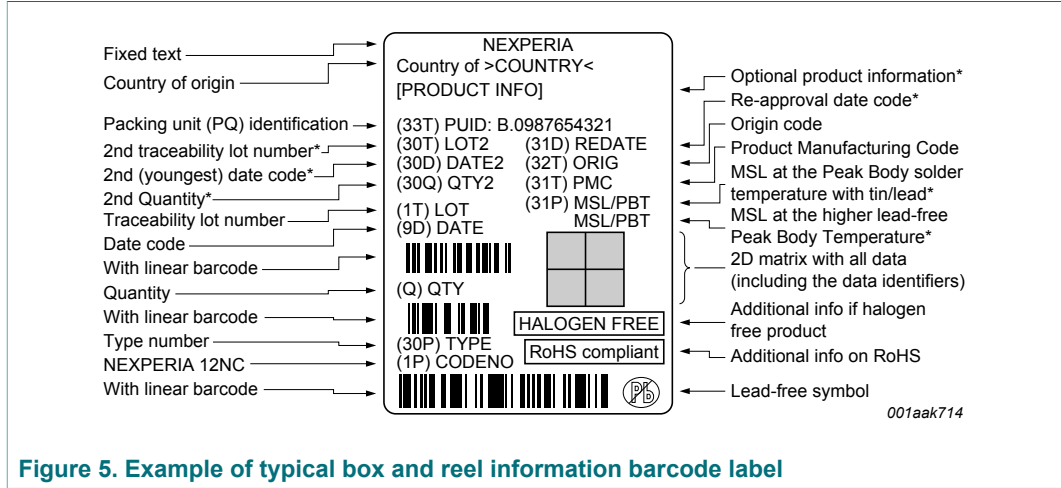

Figure 5. Example of typical box and reel information barcode label

Table 4. Barcode label dimensions

Box barcode label l × w (mm)	Reel barcode label l × w (mm)
100 × 75	100 × 75

X2QFN10; Reel pack, SMD, 7"; Q1/T1 standard product orientation; Orderable part number ending ,471 or Z; Ordering code (12NC) ending 471

6 Revision history

Table 5. Revision history

Document ID	Release date	Packing document status	Change notice	Supersedes
SOT1430-1_471 v.2	20171025	Packing information	-	SOT1430-1_471
Modifications	1. Update to Nexperia template and figures, including package 3D, packing method, and barcode labels. 2. Add "not drawn to scale" note into Figure 3.			

X2QFN10; Reel pack, SMD, 7"; Q1/T1 standard product orientation; Orderable part number ending ,471 or Z; Ordering code (12NC) ending 471

Contents

1	Packing method	1
2	Product orientation	2
3	Carrier tape dimensions	2
4	Reel dimensions	3
5	Barcode label	4
6	Revision history	5

Please be aware that important notices concerning this document and the product(s) described herein, have been included in section 'Legal information'.

© Nexperia B.V. 2017.

All rights reserved.

For more information, please visit: <http://www.nexperia.com>

For sales office addresses, please send an email to: salesaddresses@nexperia.com

Date of release: 25 October 2017