



SOT8006

DFN1308-6; Leadless ultra small plastic package; Reel pack, SMD, 7"; Q1/T1 standard product orientation; Orderable part number ending ,315 or YL; Ordering code (12NC) ending 315

Rev. 1 — 29 March 2019

Packing information

1 Packing method

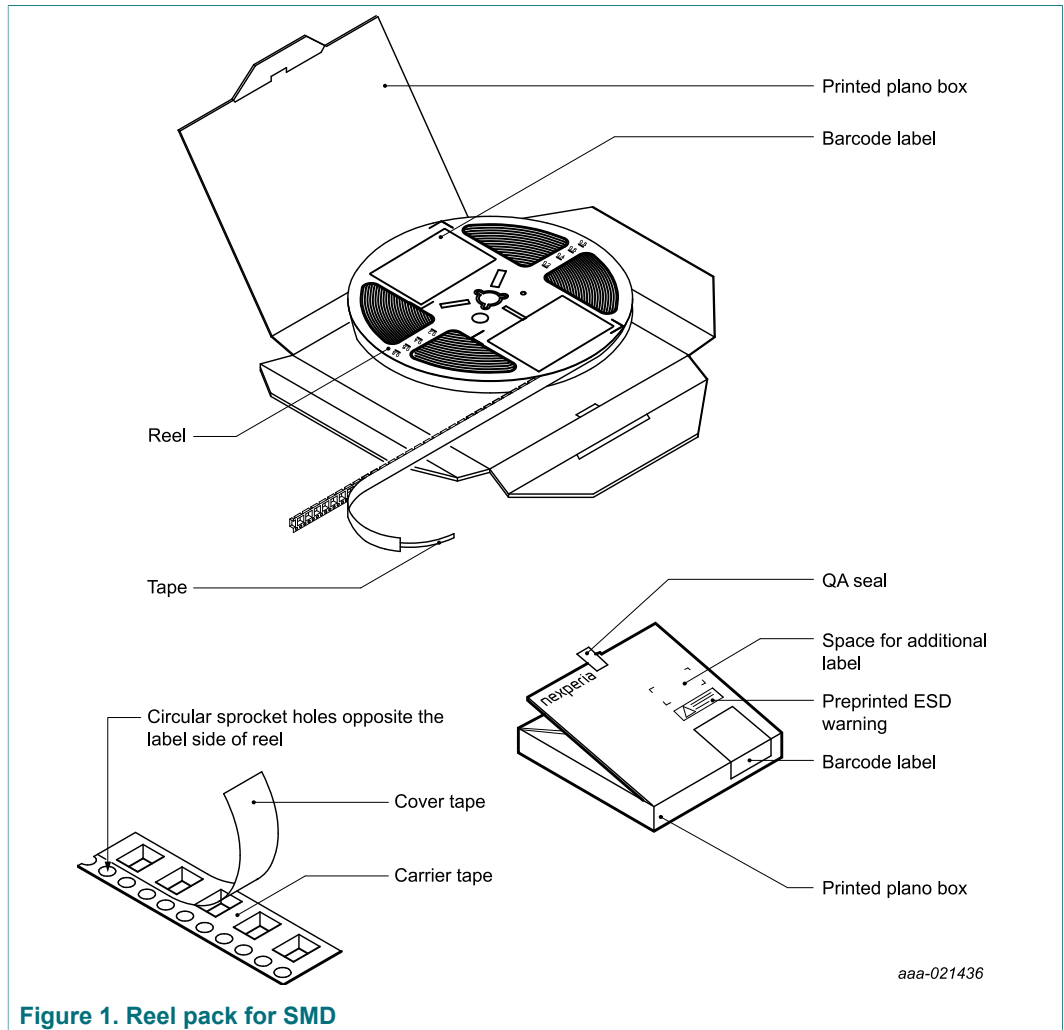

DFN1308-6; Leadless ultra small plastic package; Reel pack, SMD, 7"; Q1/T1 standard product orientation; Orderable part number ending ,315 or YL; Ordering code (12NC) ending 315

Table 1. Dimensions and quantities

Reel dimensions d × w (mm) ^[1]	SPQ/PQ (pcs) ^[2]	Reels per box	Outer box dimensions l × w × h (mm)
180 × 8	10 000	1	187 × 187 × 18

[1] d = reel diameter; w = tape width.

[2] Packing quantity dependent on specific product type. Please contact your local Nexperia representative for ordering.

2 Product orientation

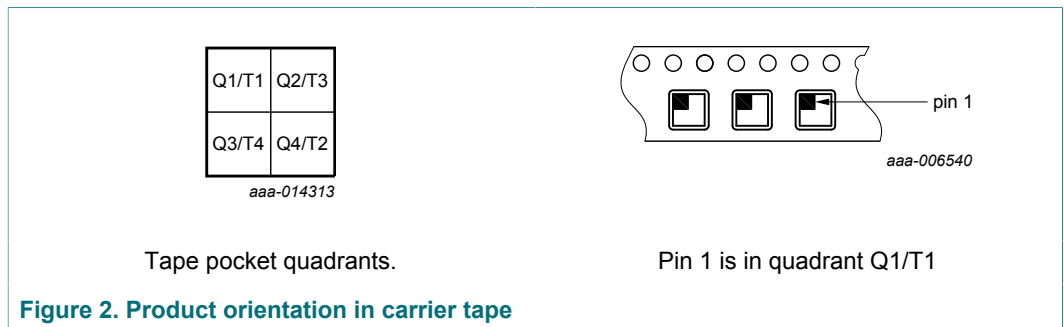

3 Carrier tape dimensions

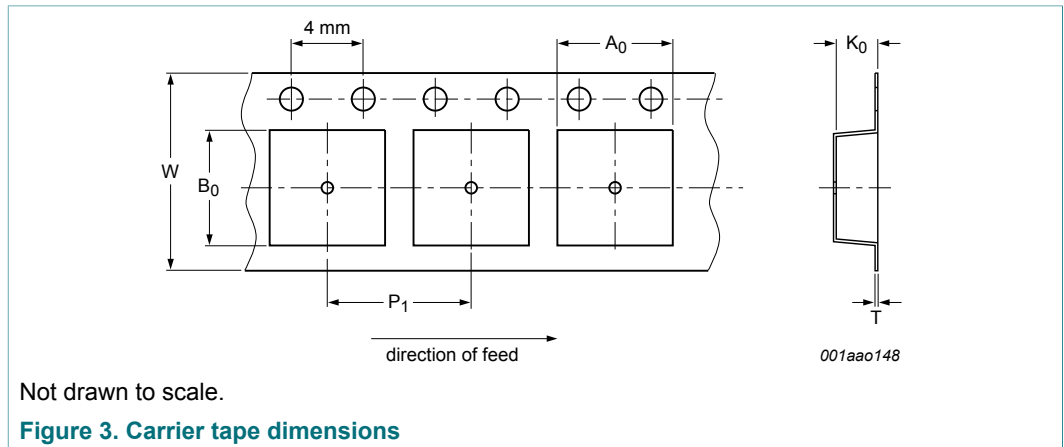

Table 2. Carrier tape dimensions

In accordance with IEC 60286-3.

A ₀ (mm)	B ₀ (mm)	T (mm)	P ₁ (mm)	W (mm)
1.00 ± 0.05	1.50 ± 0.05	0.25 ± 0.02	2.00 ± 0.05	8.0 + 0.3 / - 0.1

DFN1308-6; Leadless ultra small plastic package; Reel pack, SMD, 7"; Q1/T1 standard product orientation; Orderable part number ending ,315 or YL; Ordering code (12NC) ending 315

4 Reel dimensions

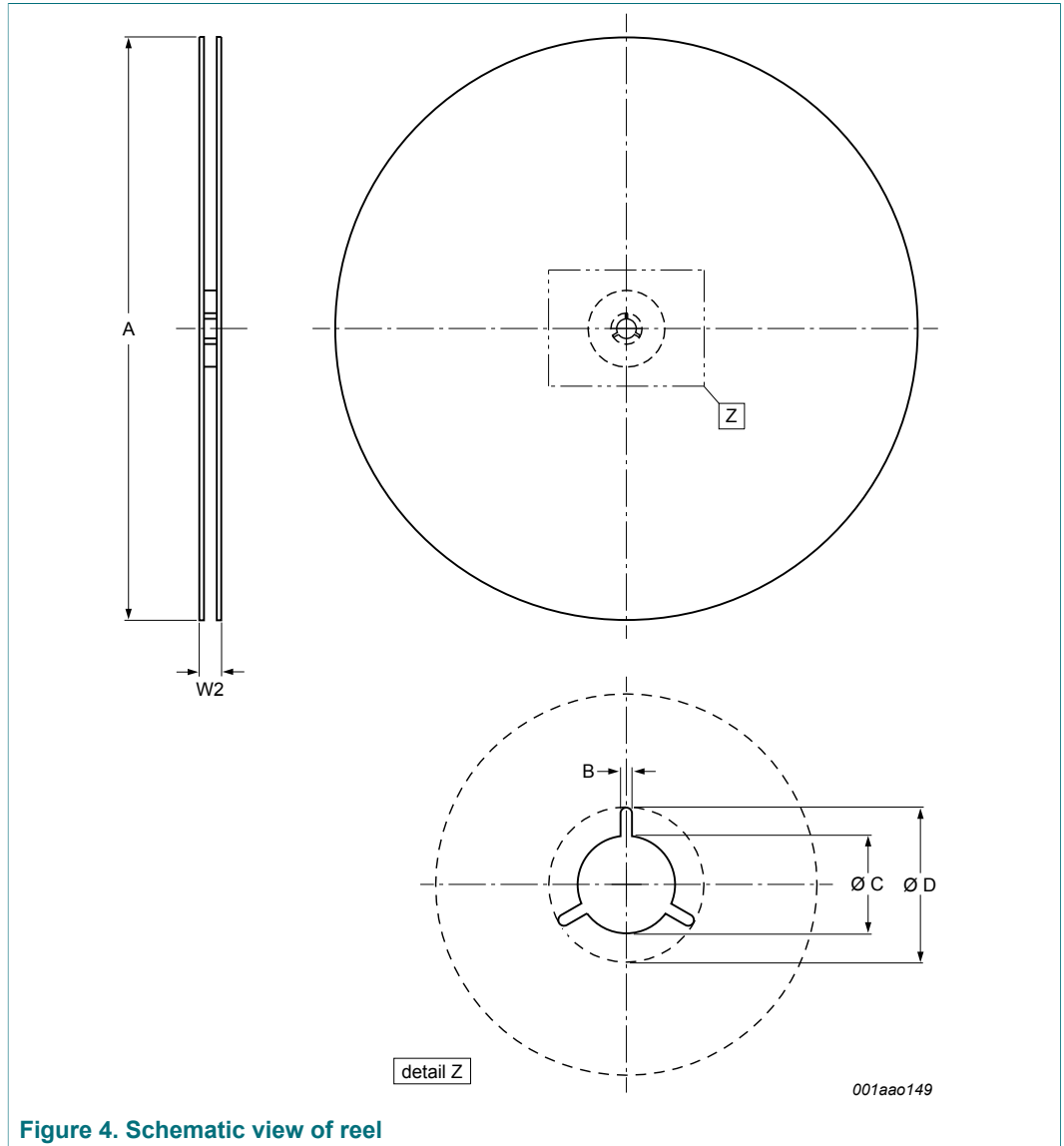

Table 3. Reel dimensions

In accordance with IEC 60286-3.

A [nom] (mm)	W2 [max] (mm)	B [min] (mm)	C [min] (mm)	D [min] (mm)
180	14.4	1.5	12.8	20.2

DFN1308-6; Leadless ultra small plastic package; Reel pack, SMD, 7"; Q1/T1 standard product orientation; Orderable part number ending ,315 or YL; Ordering code (12NC) ending 315

5 Barcode label

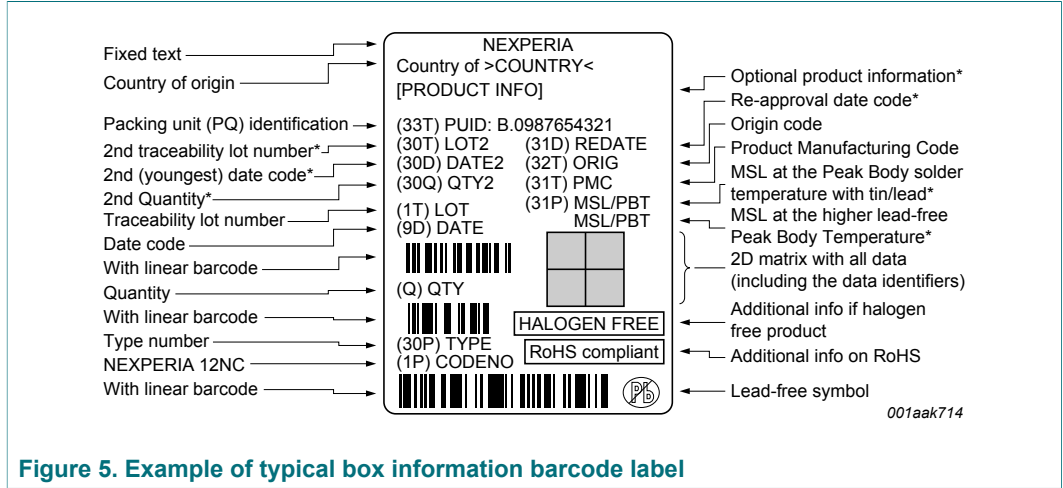

Figure 5. Example of typical box information barcode label

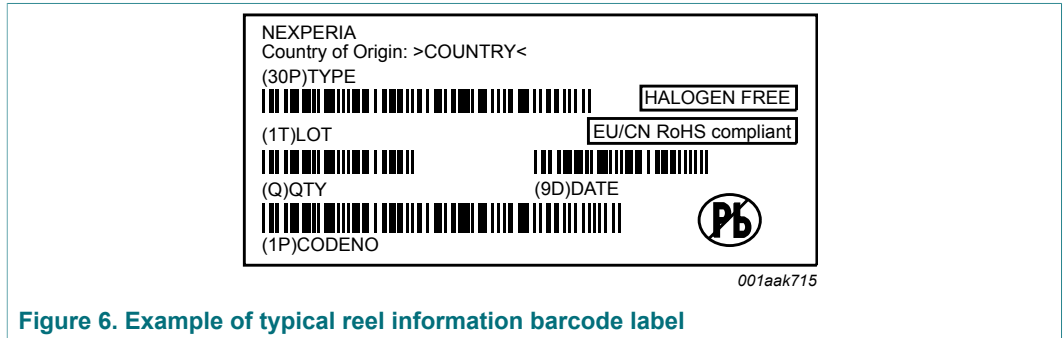

Figure 6. Example of typical reel information barcode label

Table 4. Barcode label dimensions

Box barcode label l × w (mm)	Reel barcode label l × w (mm)
100 × 75	36 × 75

DFN1308-6; Leadless ultra small plastic package; Reel pack, SMD, 7"; Q1/T1 standard product orientation; Orderable part number ending ,315 or YL; Ordering code (12NC) ending 315

6 Revision history

Table 5. Revision history

Document ID	Release date	Packing document status	Change notice	Supersedes
SOT8006_315 v.1	20190329	Packing information	-	-

DFN1308-6; Leadless ultra small plastic package; Reel pack, SMD, 7"; Q1/T1 standard product orientation; Orderable part number ending ,315 or YL; Ordering code (12NC) ending 315

Contents

1	Packing method	1
2	Product orientation	2
3	Carrier tape dimensions	2
4	Reel dimensions	3
5	Barcode label	4
6	Revision history	5

Please be aware that important notices concerning this document and the product(s) described herein, have been included in section 'Legal information'.

© Nexperia B.V. 2019.

All rights reserved.

For more information, please visit: <http://www.nexperia.com>

For sales office addresses, please send an email to: salesaddresses@nexperia.com

Date of release: 29 March 2019