

A5G38H045N

Airfast RF Power GaN Transistor

Rev. 0 — June 2022

Data Sheet: Technical Data

This 5.4 W asymmetrical Doherty RF power GaN transistor is designed for cellular base station applications requiring very wide instantaneous bandwidth capability covering the frequency range of 3400 to 4000 MHz.

This part is characterized and performance is guaranteed for applications operating in the 3400 to 4000 MHz band. There is no guarantee of performance when this part is used in applications designed outside of these frequencies.

3700–3980 MHz

- Typical Doherty Single-Carrier W-CDMA Reference Circuit Performance: $V_{DD} = 48$ Vdc, $I_{DQA} = 35$ mA, $V_{GSB} = -4.2$ Vdc, $P_{out} = 5.4$ W Avg., Input Signal PAR = 9.9 dB @ 0.01% Probability on CCDF. (1)

Frequency	G_{ps} (dB)	η_D (%)	Output PAR (dB)	ACPR (dBc)
3700 MHz	15.5	52.0	8.0	-29.1
3840 MHz	14.9	50.8	8.4	-30.7
3980 MHz	14.2	50.3	8.7	-32.3

1. All data measured in reference circuit with device soldered to printed circuit board.

Features

- High terminal impedances for optimal broadband performance
- Improved linearized error vector magnitude with next generation signal
- Able to withstand extremely high output VSWR and broadband operating conditions
- Designed for low complexity analog or digital linearization systems
- Optimized for massive MIMO active antenna systems for 5G base stations

A5G38H045N

3400–4000 MHz, 5.4 W Avg., 48 V
AIRFAST RF POWER GaN
TRANSISTOR



DFN 7 × 6.5
PLASTIC

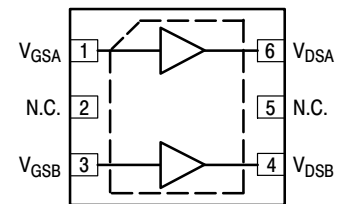

(Top View)

Note: Exposed backside of the package is the source terminal for the transistor.

Figure 1. Pin Connections

Table 1. Maximum Ratings

Rating	Symbol	Value	Unit
Drain–Source Voltage	V_{DSS}	125	Vdc
Gate–Source Voltage	V_{GS}	–8, 0	Vdc
Operating Voltage	V_{DD}	55	Vdc
Maximum Forward Gate Current, $I_{G(A+B)}$, @ $T_C = 25^\circ\text{C}$	I_{GMAX}	6.9	mA
Storage Temperature Range	T_{stg}	–65 to +150	$^\circ\text{C}$
Case Operating Temperature Range	T_C	–55 to +150	$^\circ\text{C}$
Maximum Channel Temperature	T_{CH}	225	$^\circ\text{C}$

Table 2. Recommended Operating Conditions

Rating	Symbol	Value	Unit
Operating Voltage	V_{DD}	48	Vdc

Table 3. Thermal Characteristics

Characteristic	Symbol	Value	Unit
Thermal Resistance by Infrared Measurement, Active Die Surface–to–Case Case Temperature 116°C , $P_D = 6.3\text{ W}$	$R_{\theta JC}$ (IR)	5.1 (1)	$^\circ\text{C/W}$
Thermal Resistance by Finite Element Analysis, Channel–to–Case Case Temperature 116°C , $P_D = 6.4\text{ W}$	$R_{\theta CHC}$ (FEA)	11.0 (2)	$^\circ\text{C/W}$

Table 4. ESD Protection Characteristics

Test Methodology	Class
Human Body Model (per JS–001–2017)	1B
Charge Device Model (per JS–002–2014)	C3

Table 5. Moisture Sensitivity Level

Test Methodology	Rating	Package Peak Temperature	Unit
Per JESD22–A113, IPC/JEDEC J–STD–020	3	260	$^\circ\text{C}$

Table 6. Electrical Characteristics ($T_A = 25^\circ\text{C}$ unless otherwise noted)

Characteristic	Symbol	Min	Typ	Max	Unit
----------------	--------	-----	-----	-----	------

Off Characteristics (3)

Off–State Drain Leakage ($V_{DS} = 150\text{ Vdc}$, $V_{GS} = -8\text{ Vdc}$) ($V_{DS} = 150\text{ Vdc}$, $V_{GS} = -8\text{ Vdc}$)	Carrier Peaking	$I_{D(BR)}$	—	—	1.1 2.1	mAdc
Off–State Gate Leakage ($V_{DS} = 48\text{ Vdc}$, $V_{GS} = -8\text{ Vdc}$) ($V_{DS} = 48\text{ Vdc}$, $V_{GS} = -8\text{ Vdc}$)	Carrier Peaking	I_{GLK}	–1.0 –1.0	— —	— —	mAdc

On Characteristics — Side A, Carrier

Gate Threshold Voltage ($V_{DS} = 10\text{ Vdc}$, $I_D = 2.3\text{ mAdc}$)	$V_{GS(th)}$	–4.6	–2.4	–1.8	Vdc
Gate Quiescent Voltage ($V_{DD} = 48\text{ Vdc}$, $I_{DA} = 35\text{ mAdc}$, Measured in Functional Test)	$V_{GSA(Q)}$	–2.9	–2.4	–1.9	Vdc
Gate–Source Leakage Current ($V_{DS} = 150\text{ Vdc}$, $V_{GS} = -8\text{ Vdc}$)	I_{GSS}	–0.3	—	—	mAdc

On Characteristics — Side B, Peaking

Gate Threshold Voltage ($V_{DS} = 10\text{ Vdc}$, $I_D = 4.6\text{ mAdc}$)	$V_{GS(th)}$	–4.6	–2.6	–1.9	Vdc
Gate–Source Leakage Current ($V_{DS} = 150\text{ Vdc}$, $V_{GS} = -8\text{ Vdc}$)	I_{GSS}	–1.1	—	—	mAdc

1. Refer to AN1955, *Thermal Measurement Methodology of RF Power Amplifiers*. Go to <http://www.nxp.com/RF> and search for AN1955.
2. $R_{\theta CHC}$ (FEA) must be used for purposes related to reliability and limitations on maximum channel temperature. MTTF may be estimated by the expression $MTTF$ (hours) = $10^{[A + B/(T + 273)]}$, where T is the channel temperature in degrees Celsius, $A = -11.6$ and $B = 9129$.
3. Each side of device measured separately.

(continued)

Table 6. Electrical Characteristics ($T_A = 25^\circ\text{C}$ unless otherwise noted) (continued)

Characteristic	Symbol	Min	Typ	Max	Unit
Functional Tests ⁽¹⁾ (In NXP Doherty Production Test Fixture, 50 ohm system) $V_{DD} = 48\text{ Vdc}$, $I_{DQA} = 35\text{ mA}$, $V_{GSB} = (V_t - 1.55)\text{ Vdc}$, $P_{out} = 5.4\text{ W Avg.}$, $f = 3980\text{ MHz}$, 1-tone CW. [See note on correct biasing sequence.]					
Power Gain	G_{ps}	12.8	15.1	18.0	dB
Drain Efficiency	η_D	35.8	42.2	—	%
P_{out} @ 6 dB Compression Point	P6dB	43.5	44.9	—	dBm
Wideband Ruggedness ⁽²⁾ (In NXP Doherty Reference Circuit, 50 ohm system) $I_{DQA} = 35\text{ mA}$, $V_{GSB} = -4.2\text{ Vdc}$, $f = 3840\text{ MHz}$, Additive White Gaussian Noise (AWGN) with 10 dB PAR					
ISBW of 400 MHz at 55 Vdc, 12 W Avg. Modulated Output Power (3 dB Input Overdrive from 5.4 W Avg. Modulated Output Power)	No Device Degradation				
Typical Performance ⁽²⁾ (In NXP Doherty Reference Circuit, 50 ohm system) $V_{DD} = 48\text{ Vdc}$, $I_{DQA} = 35\text{ mA}$, $V_{GSB} = -4.2\text{ Vdc}$, 3700–3980 MHz Bandwidth					
VBW Resonance Point (IMD Third Order Intermodulation Inflection Point)	VBW_{res}	—	300	—	MHz
Gain Flatness in 280 MHz Bandwidth @ $P_{out} = 5.4\text{ W Avg.}$	G_F	—	1.4	—	dB
Fast CW, 27 ms Sweep					
P_{out} @ 6 dB Compression Point	P6dB	—	48	—	W
AM/PM (Maximum value measured at the P6dB compression point across the 3700–3980 MHz bandwidth)	Φ	—	-12	—	°
Gain Variation over Temperature (-40°C to +85°C)	ΔG	—	0.035	—	dB/°C
Output Power Variation over Temperature (-40°C to +85°C)	ΔP_{6dB}	—	0.002	—	dB/°C

Table 7. Ordering Information

Device	Tape and Reel Information	Package
A5G38H045NT4	T4 Suffix = 2,500 Units, 16 mm Tape Width, 13-inch Reel	DFN 7 × 6.5

1. Part internally input matched.
2. All data measured in reference circuit with device soldered to printed circuit board.

NOTE: Correct Biasing Sequence for GaN Depletion Mode Transistors in a Doherty Configuration**Bias ON the device**

1. Set gate voltage V_{GSA} and V_{GSB} to -5 V.
2. Set drain voltage V_{DSA} and V_{DSB} to nominal supply voltage (+48 V).
3. Increase V_{GSA} (carrier side) until I_{DQA} current is attained.
4. Increase V_{GSB} (peaking side) to target bias voltage.
5. Apply RF input power to desired level.

Bias OFF the device

1. Disable RF input power.
2. Adjust gate voltage V_{GSA} and V_{GSB} to -5 V.
3. Adjust drain voltage V_{DSA} and V_{DSB} to 0 V. Allow adequate time for drain voltage to reduce to 0 V from external drain capacitors.
4. Disable V_{GSA} and V_{GSB} .

Package Information

H-PDFN-6 I/O
7 X 6.5 X 1.55 PKG, 1.6 PITCH

SOT2030-1

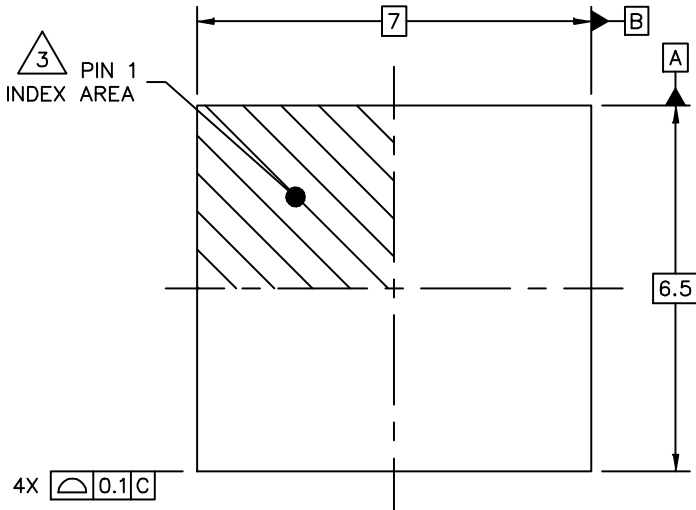

TOP VIEW

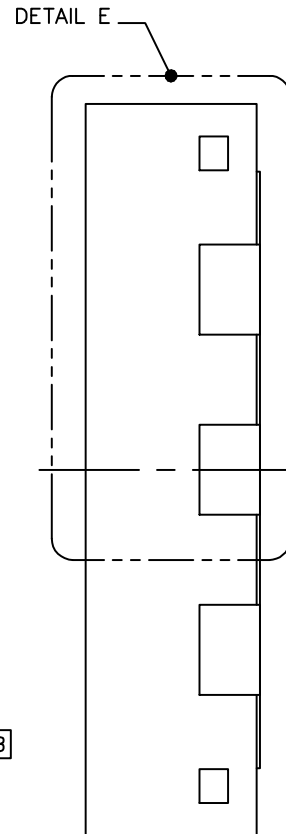

VIEW D-D

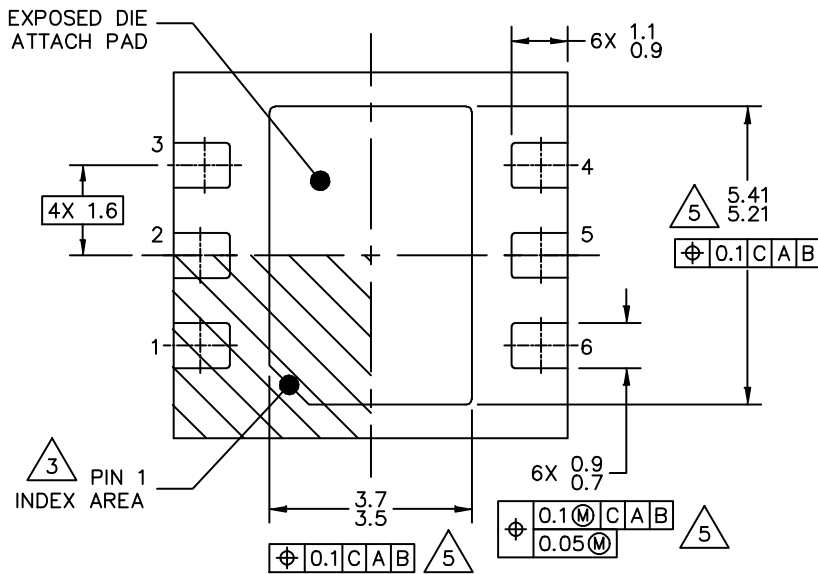

BOTTOM VIEW

© NXP B.V. ALL RIGHTS RESERVED

DATE: 02 APR 2020

MECHANICAL OUTLINE PRINT VERSION NOT TO SCALE	STANDARD: NON JEDEC	DRAWING NUMBER: 98ASA01485D	REVISION: A	PAGE: 1 OF 6
--	------------------------	--------------------------------	----------------	-----------------

H-PDFN-6 I/O
7 X 6.5 X 1.55 PKG, 1.6 PITCH

SOT2030-1

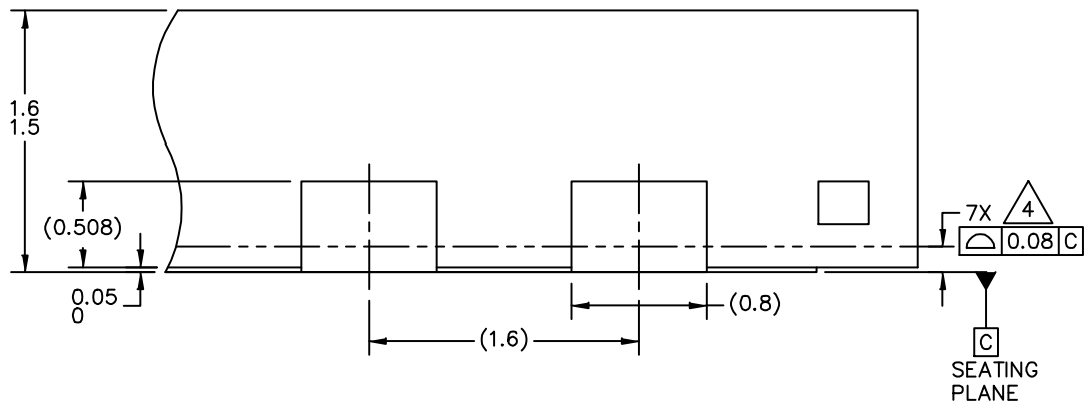

DETAIL E
VIEW ROTATED 90°CW

© NXP B.V. ALL RIGHTS RESERVED

DATE: 02 APR 2020

MECHANICAL OUTLINE PRINT VERSION NOT TO SCALE	STANDARD: NON JEDEC	DRAWING NUMBER: 98ASA01485D	REVISION: A	PAGE: 2
--	------------------------	--------------------------------	----------------	------------

H-PDFN-6 I/O
7 X 6.5 X 1.55 PKG, 1.6 PITCH

SOT2030-1

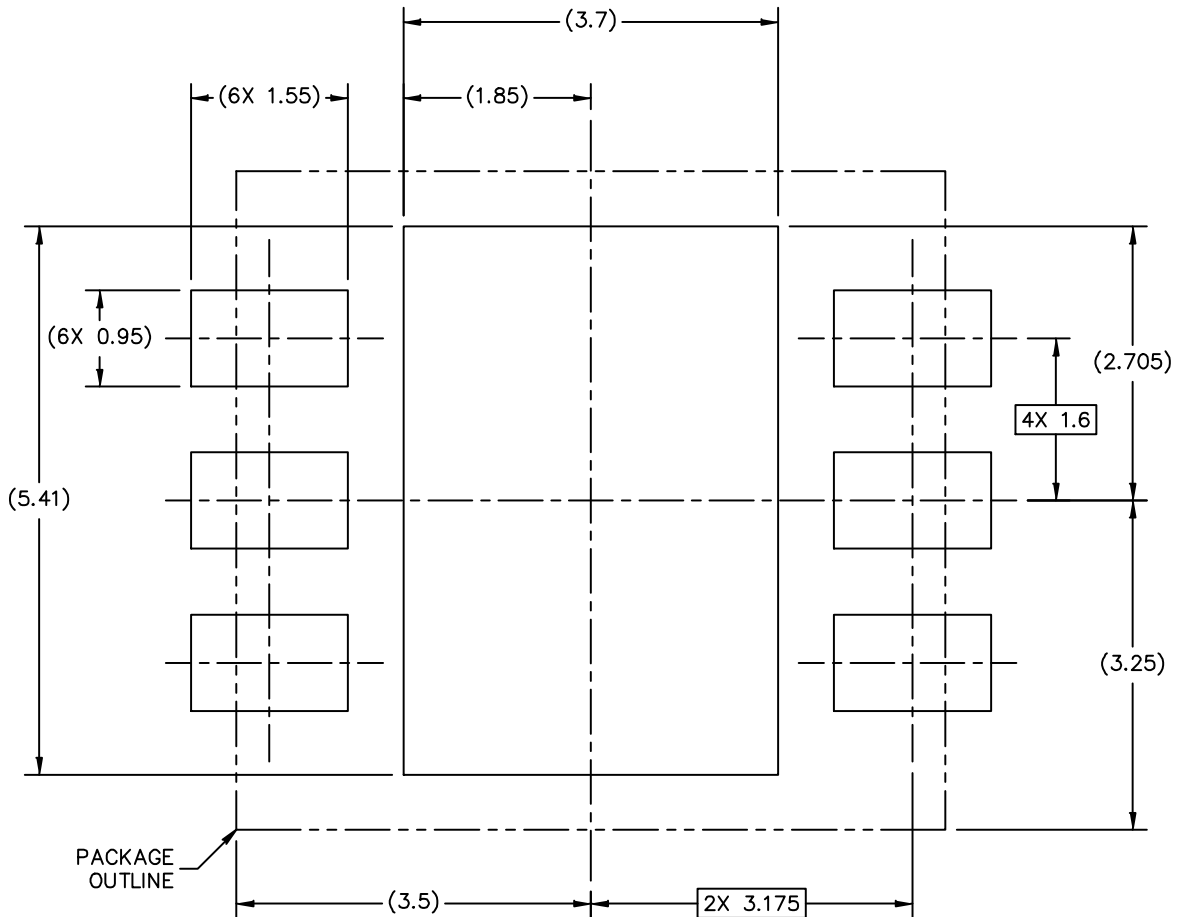

PCB DESIGN GUIDELINES – SOLDER MASK OPENING PATTERN

THIS SHEET SERVES ONLY AS A GUIDELINE TO HELP DEVELOP A USER SPECIFIC SOLUTION. DEVELOPMENT EFFORT WILL STILL BE REQUIRED BY END USERS TO OPTIMIZE PCB MOUNTING PROCESSES AND BOARD DESIGN IN ORDER TO MEET INDIVIDUAL/SPECIFIC REQUIREMENTS.

© NXP B.V. ALL RIGHTS RESERVED

DATE: 02 APR 2020

MECHANICAL OUTLINE PRINT VERSION NOT TO SCALE	STANDARD: NON JEDEC	DRAWING NUMBER: 98ASA01485D	REVISION: A	PAGE: 3
--	------------------------	--------------------------------	----------------	------------

H-PDFN-6 I/O
7 X 6.5 X 1.55 PKG, 1.6 PITCH

SOT2030-1

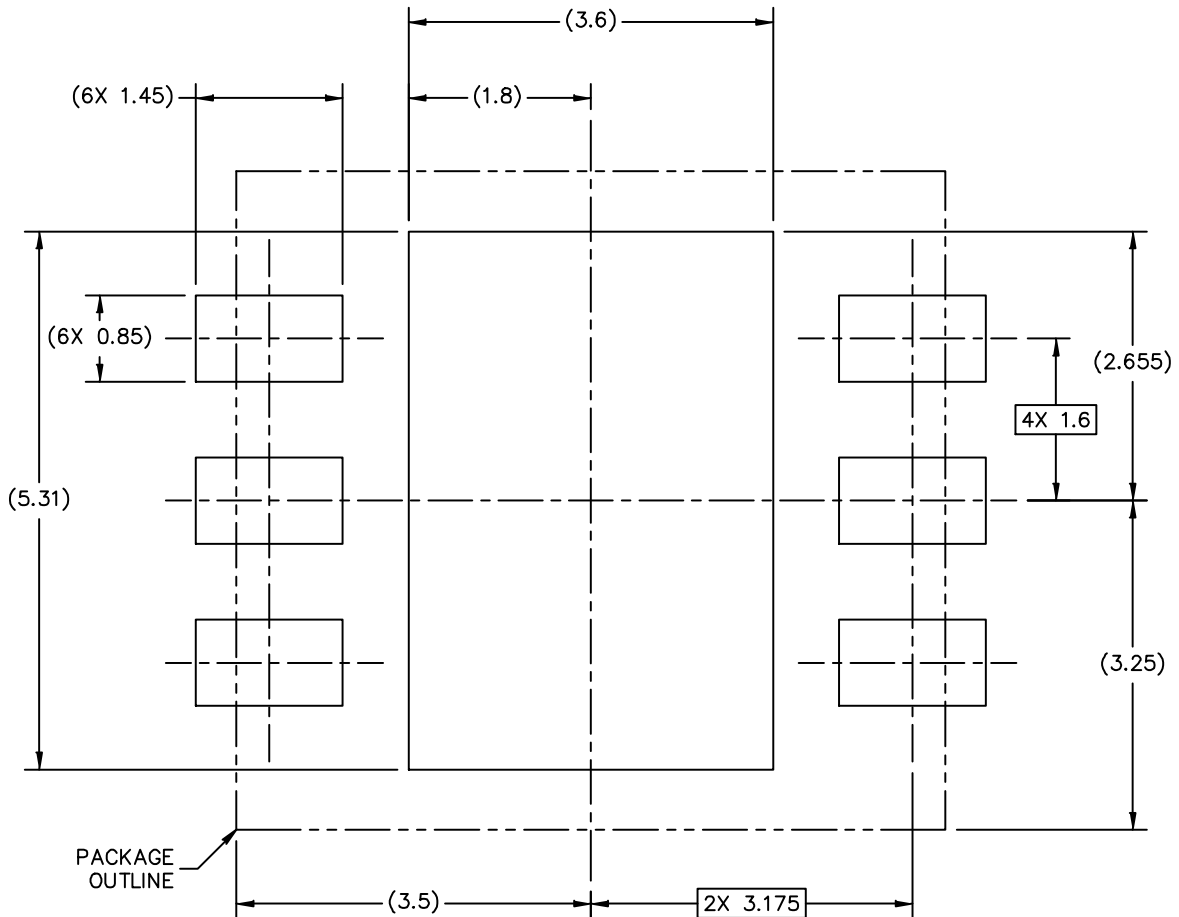

PCB DESIGN GUIDELINES – I/O PADS AND SOLDERABLE AREA

THIS SHEET SERVES ONLY AS A GUIDELINE TO HELP DEVELOP A USER SPECIFIC SOLUTION. DEVELOPMENT EFFORT WILL STILL BE REQUIRED BY END USERS TO OPTIMIZE PCB MOUNTING PROCESSES AND BOARD DESIGN IN ORDER TO MEET INDIVIDUAL/SPECIFIC REQUIREMENTS.

© NXP B.V. ALL RIGHTS RESERVED

DATE: 02 APR 2020

MECHANICAL OUTLINE PRINT VERSION NOT TO SCALE	STANDARD: NON JEDEC	DRAWING NUMBER: 98ASA01485D	REVISION: A	PAGE: 4
--	------------------------	--------------------------------	----------------	------------

H-PDFN-6 I/O
7 X 6.5 X 1.55 PKG, 1.6 PITCH

SOT2030-1

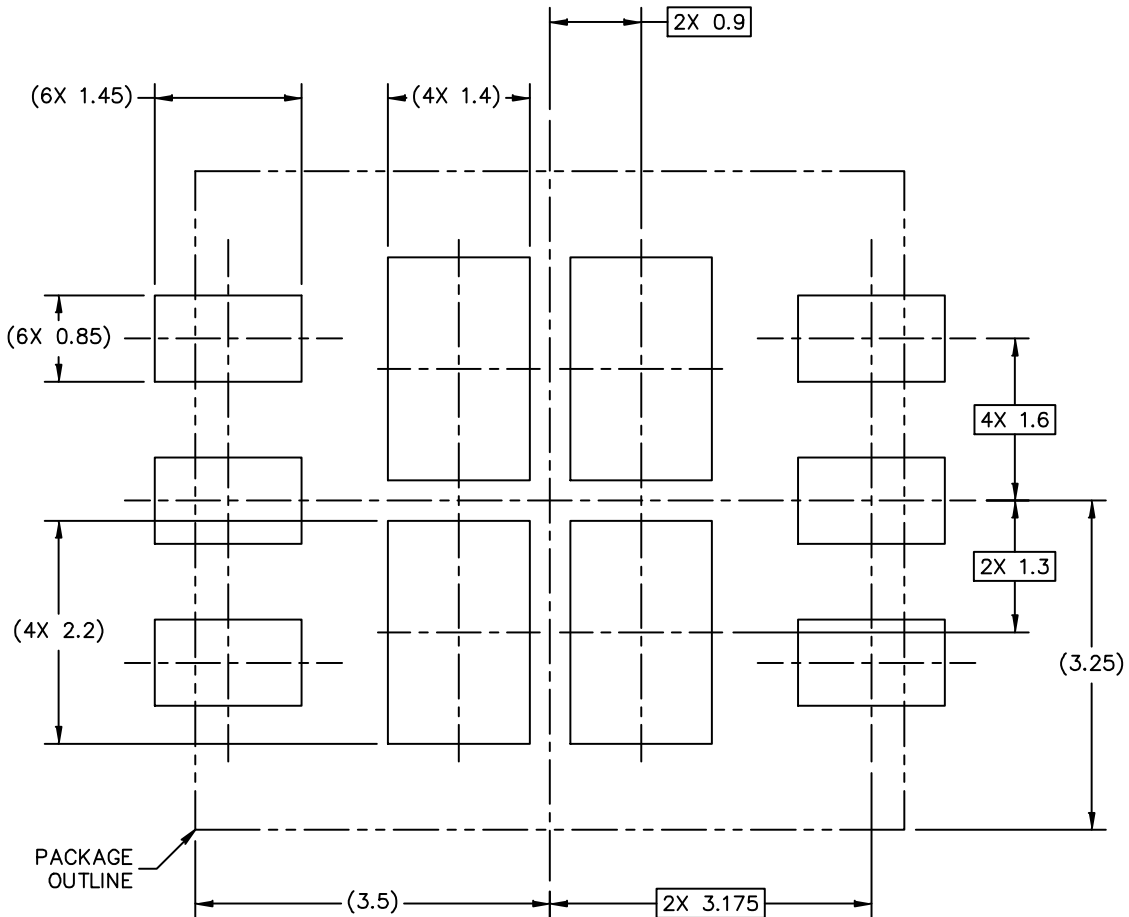

STENCIL THICKNESS 0.125 OR 0.15

PCB DESIGN GUIDELINES – SOLDER PASTE STENCIL

THIS SHEET SERVES ONLY AS A GUIDELINE TO HELP DEVELOP A USER SPECIFIC SOLUTION. DEVELOPMENT EFFORT WILL STILL BE REQUIRED BY END USERS TO OPTIMIZE PCB MOUNTING PROCESSES AND BOARD DESIGN IN ORDER TO MEET INDIVIDUAL/SPECIFIC REQUIREMENTS.

© NXP B.V. ALL RIGHTS RESERVED

DATE: 02 APR 2020

MECHANICAL OUTLINE PRINT VERSION NOT TO SCALE	STANDARD: NON JEDEC	DRAWING NUMBER: 98ASA01485D	REVISION: A	PAGE: 5
--	------------------------	--------------------------------	----------------	------------

H-PDFN-6 I/O
7 X 6.5 X 1.55 PKG, 1.6 PITCH

SOT2030-1

NOTES:

1. ALL DIMENSIONS ARE IN MILLIMETERS.
2. DIMENSIONING AND TOLERANCING PER ASME Y14.5M-1994.
3. PIN 1 FEATURE SHAPE, SIZE AND LOCATION MAY VARY.
4. COPLANARITY APPLIES TO LEADS AND DIE ATTACH FLAG.
5. RADIUS ON LEAD AND DIE ATTACH FLAG IS OPTIONAL.

© NXP B.V. ALL RIGHTS RESERVED

DATE: 02 APR 2020

MECHANICAL OUTLINE PRINT VERSION NOT TO SCALE	STANDARD: NON JEDEC	DRAWING NUMBER: 98ASA01485D	REVISION: A	PAGE: 6
--	------------------------	--------------------------------	----------------	------------

Product Documentation and Software

Refer to the following resources to aid your design process.

Application Notes

- AN1907: Solder Reflow Attach Method for High Power RF Devices in Plastic Packages
- AN1955: Thermal Measurement Methodology of RF Power Amplifiers

Software

- .s2p File

Revision History

The following table summarizes revisions to this document.

Revision	Date	Description
0	June 2022	<ul style="list-style-type: none">• Initial release of data sheet

How to Reach Us

Home Page:
nxp.com

Web Support::
nxp.com/support

Information in this document is provided solely to enable system and software implementers to use NXP products. There are no express or implied copyright licenses granted hereunder to design or fabricate any integrated circuits based on the information in this document. NXP reserves the right to make changes without further notice to any products herein.

NXP makes no warranty, representation, or guarantee regarding the suitability of its products for any particular purpose, nor does NXP assume any liability arising out of the application or use of any product or circuit, and specifically disclaims any and all liability, including without limitation consequential or incidental damages. "Typical" parameters that may be provided in NXP data sheets and/or specifications can and do vary in different applications, and actual performance may vary over time. All operating parameters, including "typicals," must be validated for each customer application by customer's technical experts. NXP does not convey any license under its patent rights nor the rights of others. NXP sells products pursuant to standard terms and conditions of sale, which can be found at the following address: nxp.com/SalesTermsandConditions.

NXP, the NXP logo and Airfast are trademarks of NXP B.V. All other product or service names are the property of their respective owners.

© NXP B.V. 2022

All rights reserved.

For more information, please visit: <http://www.nxp.com>

For sales office addresses, please send an email to: salesaddresses@nxp.com

Date of release: June 2022
Document identifier: A5G38H045N