

# DSP56603EVM

## Advance Information DSP56603EVM Evaluation Module

The DSP56603 Evaluation Module (DSP56603EVM) is designed as a low-cost platform for developing real-time software and hardware products to support a new generation of applications in wireless and wireline communications, multimedia, speech, control, and general digital signal processing. The user can download software to on-chip or on-board RAM, then run and debug it. The user can also connect hardware, such as external memories and A/D or D/A converters, for product development. The 16-bit precision of the DSP56603 Digital Signal Processor (DSP) combined with the on-board 32 K of external SRAM and Crystal Semiconductor's CS4215 stereo, CD-quality, audio codec makes the DSP56603EVM ideal for implementing and demonstrating many communications and speech processing algorithms, as well as for learning the architecture and instruction set of the DSP56603 processor. **Figure 1** shows the functional block diagram for the DSP56603EVM.

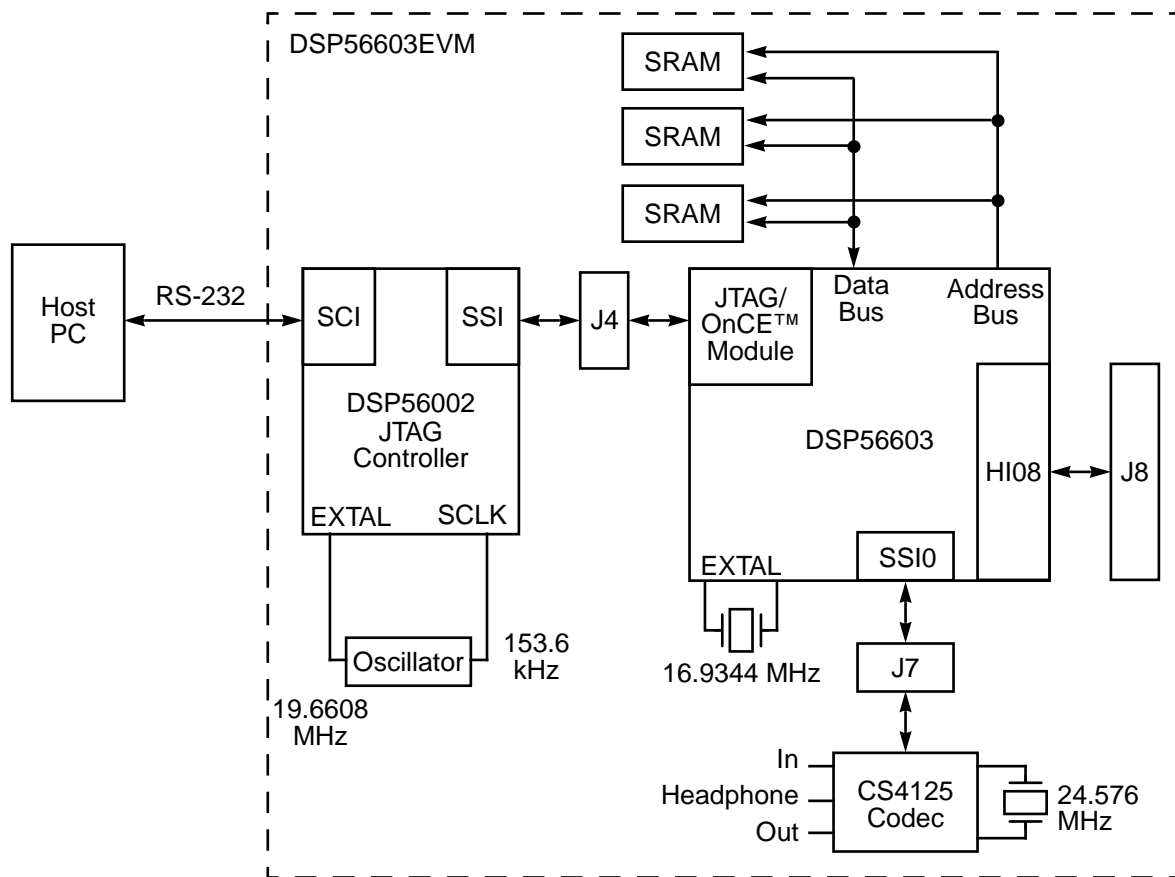

AA0851

**Figure 1** DSP56603EVM Functional Block Diagram

This document contains information on a new product. Specifications and information herein are subject to change without notice.

Preliminary Information

## HARDWARE FEATURES

- 16-bit DSP56603 Digital Signal Processor
  - High Performance DSP56600 Core
    - 60 Million Instructions Per Second (MIPS) with a 60 MHz clock (at 2.7 volts)
    - Object-code compatible with the DSP56000 and DSP56300 cores
    - Highly parallel instruction set
    - Fully pipelined 16 × 16-bit parallel Multiplier-Accumulator (MAC)
    - Two 40-bit accumulators including extension bits
    - 40-bit parallel barrel shifter
    - Position Independent Code (PIC) Support
    - Unique DSP addressing modes
    - On-chip memory-expandable hardware stack
    - Nested hardware DO loops
    - Fast auto-return interrupts
    - On-chip Phase Lock Loop (PLL)
    - On-Chip Emulation (OnCE™) module
    - JTAG port
    - Address Tracing mode reflects internal Program RAM accesses at external port
    - On-chip support for software patching and enhancements
  - On-Chip Memories
    - Program RAM, X data RAM, and Y data RAM size is programmable:
 

Switch Mode	Program RAM Size	X Data RAM Size	Y Data RAM Size
disabled	16.5 K × 24-bit	8 K × 16-bit	8 K × 16-bit
enabled	11.5 K × 24-bit	10.5 K × 16-bit	10.5 K × 16-bit
    - 3 K × 24-bit bootstrap ROM
  - Off-Chip Memory Expansion
    - Program memory expansion to one memory space of 64 K × 24-bit words

**Preliminary Information**

- On-Chip Peripherals
  - Enhanced DSP56000-like 8-bit parallel Host Interface (HI08)
  - Two Synchronous Serial Interfaces (SSI0 and SSI1)
  - Triple timer module
  - As many as thirty-four programmable General Purpose Input/Output (GPIO) pins, depending on which peripherals are enabled
- Reduced Power Dissipation
  - Very low power CMOS design
  - Wait and Stop low power standby modes
  - Fully static logic, operation from the device maximum frequency down to DC
- 32 K × 24-bit fast Static RAM for external Program memory expansion
- 16-bit CD-quality audio codec
  - Two channels of 16-bit Analog-to-Digital (A/D) conversion
  - Two channels of 16-bit Digital-to-Analog (D/A) conversion
  - Software-selectable 8-bit and 16-bit data formats, including  $\mu$ -law and A-law companding
  - Stereo jacks for audio input, output, and headphones
- JTAG Controller
  - On-board DSP56002 for high-speed JTAG/OnCE serial transfers
  - JTAG connector for use with the Application Development System (ADS) command converter card
- Connectors
  - Host port connector
  - External memory expansion connector
  - SSI0, SSI1, and GPIO connector
  - RS-232 serial connector to host computer

### Preliminary Information

## SOFTWARE FEATURES

- Motorola's DSP56xxx cross assembler
  - Produces DSP56603 binary code from source code using labels, sections, and macro definitions incorporating the DSP's complete instruction set, all addressing modes, and all memory spaces
  - Offers macros, expression evaluation, and functions for strings, data conversion, and transcendental functions
  - Creates reports for cross-references, instruction cycle count, and memory usage
  - Provides extensive error checking and reporting
- Domain Technologies debug software with Windows-based user interface
  - Symbolic debugging
  - Windows for data, code, DSP registers, commands, peripherals, etc.
  - Data and registers displayed in fractional, decimal, or hexadecimal format
  - Graphical display of memory segments
  - Up to eight simultaneous software breakpoints
  - Built-in-line assembler and disassembler
- Demonstration software and example pass-through code
- Self-test files—executable and source code

## INCLUDED WITH THE DSP56603EVM

The DSP56603EVM kit contains the following items:

- DSP56603 Evaluation Module board
- *DSP56603EVM Product Information (DSP56603EVMP/D—this document)*
  - Overview description of the DSP56603EVM, including block diagram and list of features
- *DSP56603EVM User's Manual (DSP56603EVMUM/AD)*
  - Detailed functional description of the DSP56603EVM, including requirements, installation, and general operating guidelines
- *DSP56600 Family Manual (DSP56600FM/AD)*
  - Detailed description of the DSP56600 family processor core and instruction set
- *DSP56603 User's Manual (DSP56603UM/AD)*
  - Detailed functional description of the DSP56603 memory configuration, operation, and register programming
- *DSP56603 Technical Data (DSP56603/D)*
  - DSP56603 features list and physical, electrical, timing, and package specifications
- *DSP56603 Chip Errata*
  - Differences between how the DSP56603 is described in previous documentation and how a particular mask version of the chip actually operates
- Crystal Semiconductor CS4215 16-Bit Multimedia Audio Codec Data Sheet
- Domain Technologies Debug-56K Debugger manual for Motorola's 16- and 24-bit DSPs
- GUI Debugger from Domain Technologies (one diskette)
- Assembler/Linker/example software from Motorola (one diskette)
- Motorola Digital Signal Processor Registration Form

### Preliminary Information

## USER REQUIREMENTS

The user must provide the following:

- Power supply (7–9 V AC or DC with 2.1 mm power connector)
- RS-232 cable (DB9 male to DB9 female)
- Audio source, headphones, and a cable with 1/8-inch stereo plugs
- IBM PC compatible computer (386 class or higher) running Windows 3.1 (or higher) with an RS-232 serial port capable of 9,600–57,600 bit-per-second operation, 4 Mbytes RAM minimum, 3-1/2 inch diskette drive, hard drive with a minimum of 4 Mbyte of free disk space, and a mouse

To operate the DSP56603EVM with any system other than a Windows-based PC, the use of the Motorola DSPCOMMAND Command Converter board and DSPxHOST Host Adapter board is required (see *DSPTOOLSP/D*). In addition, the DSPCOMMAND and DSPxHOST may be required to use some third-party products developed for the DSP56603EVM.



Preliminary Information



OnCE and Mfax are trademarks of Motorola, Inc.



Motorola reserves the right to make changes without further notice to any products herein. Motorola makes no warranty, representation or guarantee regarding the suitability of its products for any particular purpose, nor does Motorola assume any liability arising out of the application or use of any product or circuit, and specifically disclaims any and all liability, including without limitation consequential or incidental damages. "typical" parameters which may be provided in Motorola data sheets and/or specifications can and do vary in different applications and actual performance may vary over time. All operating parameters, including "Typicals" must be validated for each customer application by customer's technical experts. Motorola does not convey any license under its patent rights nor the rights of others. Motorola products are not designed, intended, or authorized for use as components in systems intended for surgical implant into the body, or other applications intended to support life, or for any other application in which the failure of the Motorola product could create a situation where personal injury or death may occur. Should Buyer purchase or use Motorola products for any such unintended or unauthorized application, Buyer shall indemnify and hold Motorola and its officers, employees, subsidiaries, affiliates, and distributors harmless against all claims, costs, damages, and expenses, and reasonable attorney fees arising out of, directly or indirectly, any claim of personal injury or death associated with such unintended or unauthorized use, even if such claim alleges that Motorola was negligent regarding the design or manufacture of the part. Motorola and  are registered trademarks of Motorola, Inc. Motorola, Inc. is an Equal Opportunity/Affirmative Action Employer.

How to reach us:

**USA/Europe/Locations Not Listed:**

Motorola Literature Distribution  
P.O. Box 20912  
Phoenix, Arizona 85036  
1 (800) 441-2447 or  
1 (602) 303-5454

**Mfax™:**

RMFAX0@email.sps.mot.com  
TOUCHTONE (602) 244-6609

**Asia/Pacific:**

Motorola Semiconductors H.K. Ltd.  
8B Tai Ping Industrial Park  
51 Ting Kok Road  
Tai Po, N.T., Hong Kong  
852-2662928

**Technical Resource Center:**

1 (800) 521-6274

**DSP Helpline**

dsphelp@dsp.sps.mot.com

**Japan:**

Nippon Motorola Ltd.  
Tatsumi-SPD-JLDC  
6F Seibu-Butsuryu-Center  
3-14-2 Tatsumi Koto-Ku  
Tokyo 135, Japan  
81-3-3521-8315

**Internet:**

<http://www.motorola-dsp.com>



**For More Information On This Product,  
Go to: [www.freescale.com](http://www.freescale.com)**