



ARCHIVED BY FREESCALE SEMICONDUCTOR, INC. 2005

1.1 GHz Low Power Dual Modulus Prescaler

The MC12038A can be used with CMOS synthesizers requiring positive edges to trigger internal counters such as Motorola's MC145XXX series in a PLL to provide tuning signals up to 1.1 GHz in programmable frequency steps.

A Divide Ratio Control (SW) permits selection of a 127/128 or 255/256 divide ratio as desired.

The Modulus Control (MC) selects the proper divide number after SW has been biased to select the desired divide ratio.

- 1.1 GHz Toggle Frequency
- Supply Voltage of 4.5 to 5.5 V
- Low-Power 4.8 mA Typical
- Operating Temperature Range of -40 to 85°C
- Short Setup Time (t_{set}) 16ns Maximum @ 1.1 GHz
- Modulus Control Input Level Is Compatible With Standard CMOS and TTL
- On-Chip Output Termination

DEVICE TO BE PHASED OUT.
No replacement available.

FUNCTION TABLE

SW	MC	Divide Ratio
H	H	127
H	L	128
L	H	255
L	L	256

NOTES: 1. SW: H = V_{CC} , L = Open. A logic L can also be applied by grounding this pin, but this is not recommended due to increased power consumption.
2. MC: H = 2.0 V to V_{CC} , L = GND to 0.8 V.

DESIGN GUIDE

Criteria	Value	Unit
Internal Gate Count*	67	ea
Internal Gate Propagation Delay	200	ps
Internal Gate Power Dissipation	0.75	mW
Speed Power Product	0.15	pJ

NOTE: * Equivalent to a two-input NAND gate

MAXIMUM RATINGS

Characteristic	Symbol	Range	Unit
Power Supply Voltage, Pin 2	V_{CC}	-0.5 to 7.0	Vdc
Operating Temperature Range	T_A	-40 to 85	°C
Storage Temperature Range	T_{stg}	-65 to 150	°C
Modulus Control Input, Pin 6	MC	-0.5 to 6.5	Vdc

NOTE: ESD data available upon request.

MC12038A

MECIPLL COMPONENTS ÷127/128, ÷255/256 DUAL MODULUS PRESCALER

SEMICONDUCTOR
TECHNICAL DATA



D SUFFIX
PLASTIC PACKAGE
CASE 751
(SO-8)

PIN CONNECTIONS

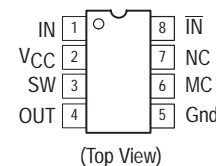

ORDERING INFORMATION

Device	Operating Temperature Range	Package
MC12038AD	$T_A = -40$ to 85°C	SO-8

Freescale Semiconductor, Inc. ARCHIVED BY FREESCALE SEMICONDUCTOR, INC. 2005

ARCHIVE INFORMATION

ELECTRICAL CHARACTERISTICS ($V_{CC} = 4.5$ to $5.5V$; $T_A = -40$ to $85^\circ C$, unless otherwise noted.)

Characteristic	Symbol	Min	Typ	Max	Unit
Toggle Frequency (Sine Wave Input)	f_t	0.1	1.4	1.1	GHz
Supply Current Output Unloaded (Pin 2) at 5.0 Vdc	I_{CC}	–	4.8	6.5	mA
Modulus Control Input High (MC)	V_{IH1}	2.0	–	V_{CC}	V
Modulus Control Input Low (MC)	V_{IL1}	–	–	0.8	V
Divide Ratio Control Input High (SW)	V_{IH2}	V_{CC}	V_{CC}	V_{CC}	Vdc
Divide Ratio Control Input Low (SW)	V_{IL2}	Open	Open	Open	–
Output Voltage Swing ($C_L = 8.0$ pF)	V_{out}	1.0	1.6	–	V_{pp}
Modulus Setup Time MC to Out	t_{set}	–	11	16	ns
Input Voltage Sensitivity 250–1100 MHz 100–250 MHz	$V_{in(min)}$	100 400	– –	1500 1500	mVpp

Figure 1. Logic Diagram (MC12038A)

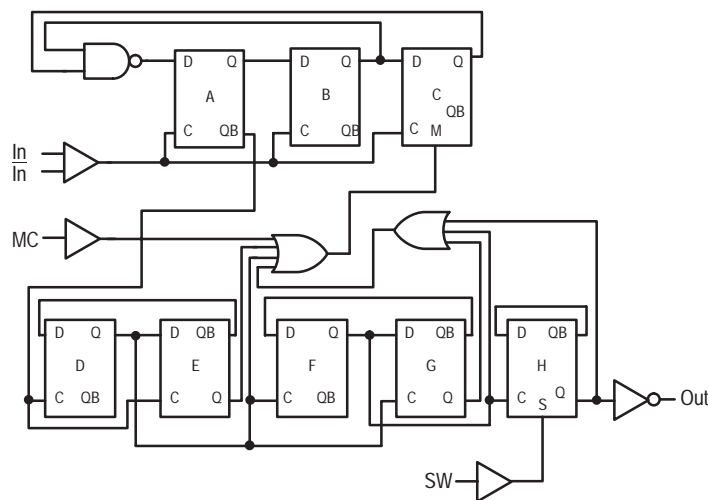
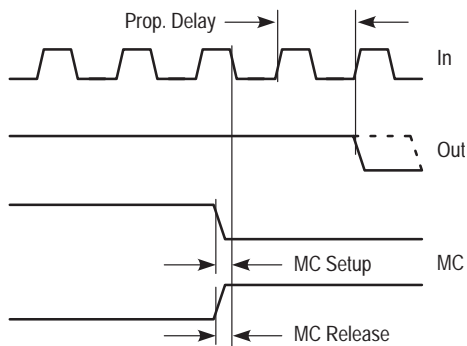
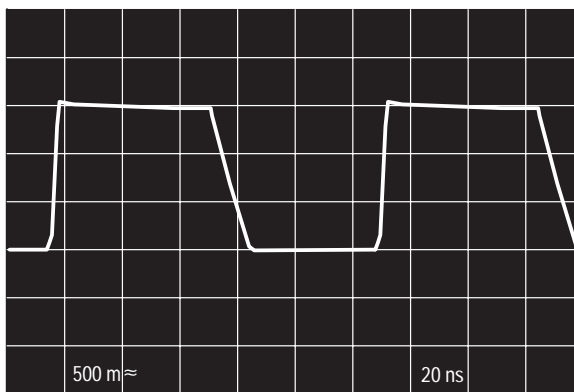

Figure 2. Modulus Setup Time



Modulus setup time MC to out is the MC setup or MC release plus the prop delay.

Figure 3. Typical Output Waveforms



(±128, 1.1 GHz Input Frequency, $V_{CC} = 5.0$ V, $T_A = 25^\circ C$, Output Loaded)

Figure 4. AC Test Circuit

ARCHIVED BY FREESCALE SEMICONDUCTOR, INC. 2005

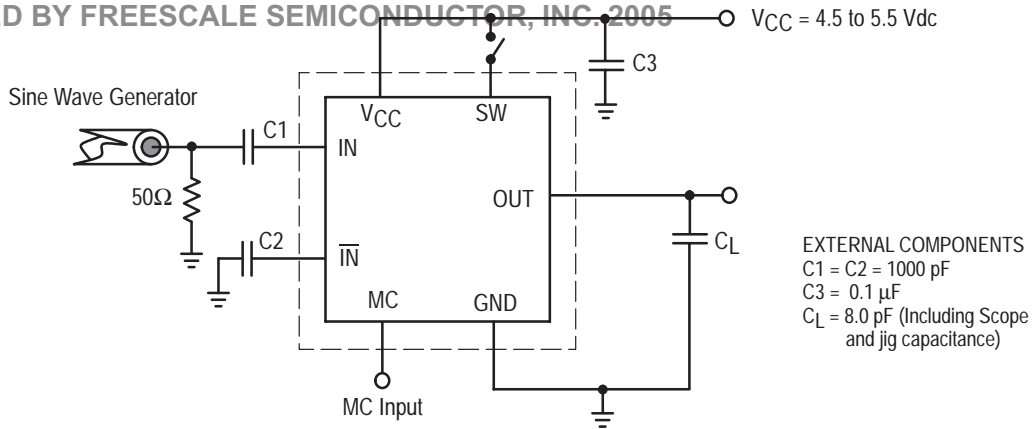

Figure 5. Input Signal Amplitude versus Input Frequency

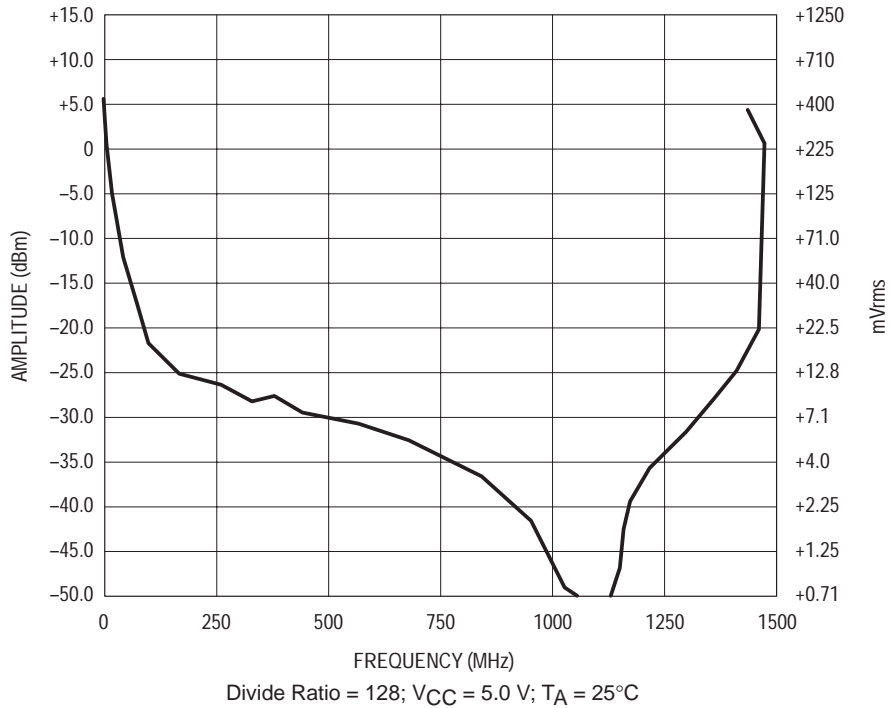

Figure 6. Output Amplitude versus Input Frequency

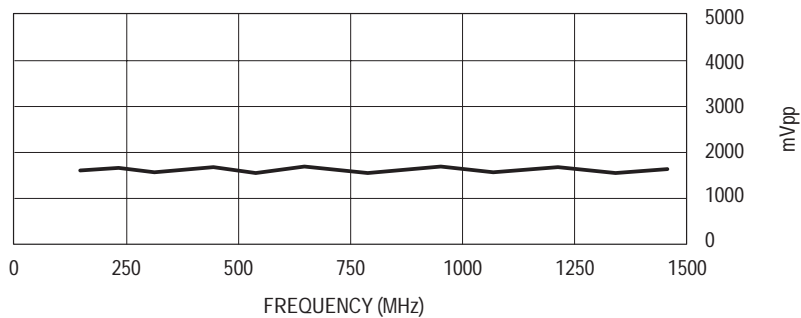
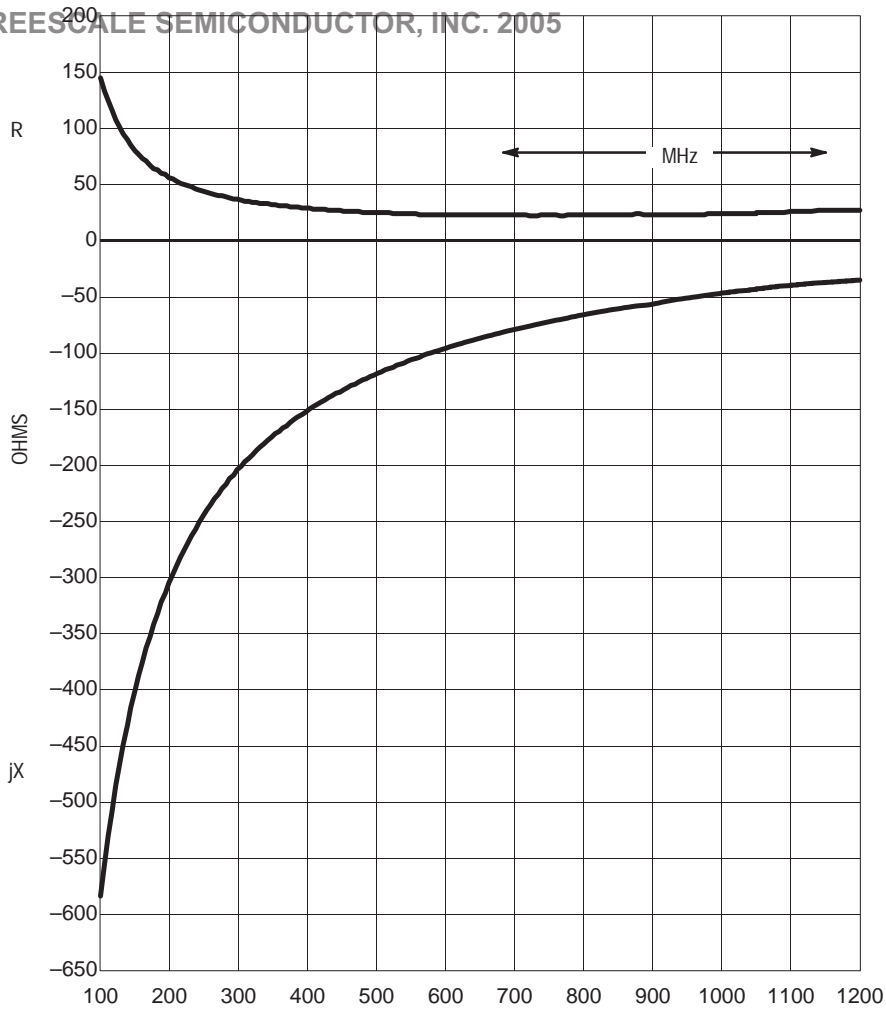



Figure 7. Typical Input Impedance versus Input Frequency

ARCHIVED BY FREESCALE SEMICONDUCTOR, INC. 2005



Freescale Semiconductor, Inc.
ARCHIVED BY FREESCALE SEMICONDUCTOR, INC. 2005

ARCHIVE INFORMATION

OUTLINE DIMENSIONS

ARCHIVED BY FREESCALE SEMICONDUCTOR, INC. 2005

D SUFFIX
 PLASTIC PACKAGE
 CASE 751-06
 (SO-8)
 ISSUE T

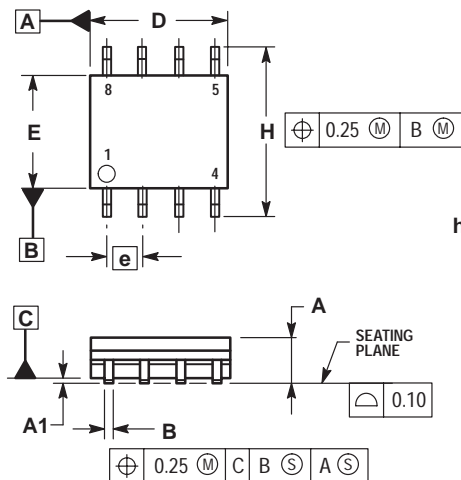

- NOTES:
1. DIMENSIONING AND TOLERANCING PER ASME Y14.5M, 1994.
 2. DIMENSIONS ARE IN MILLIMETER.
 3. DIMENSION D AND E DO NOT INCLUDE MOLD PROTRUSION.
 4. MAXIMUM MOLD PROTRUSION 0.15 PER SIDE.
 5. DIMENSION B DOES NOT INCLUDE DAMBAR PROTRUSION. ALLOWABLE DAMBAR PROTRUSION SHALL BE 0.127 TOTAL IN EXCESS OF THE B DIMENSION AT MAXIMUM MATERIAL CONDITION.

DIM	MILLIMETERS	
	MIN	MAX
A	1.35	1.75
A1	0.10	0.25
B	0.35	0.49
C	0.19	0.25
D	4.80	5.00
E	3.80	4.00
e	1.27 BSC	
H	5.80	6.20
h	0.25	0.50
L	0.40	1.25
θ	0°	7°

Freescale Semiconductor, Inc. ARCHIVED BY FREESCALE SEMICONDUCTOR, INC. 2005

ARCHIVE INFORMATION

Motorola reserves the right to make changes without further notice to any products herein. Motorola makes no warranty, representation or guarantee regarding the suitability of its products for any particular purpose, nor does Motorola assume any liability arising out of the application or use of any product or circuit, and specifically disclaims any and all liability, including without limitation consequential or incidental damages. "Typical" parameters which may be provided in Motorola data sheets and/or specifications can and do vary in different applications and actual performance may vary over time. All operating parameters, including "Typicals" must be validated for each customer application by customer's technical experts. Motorola does not convey any license under its patent rights nor the rights of others. Motorola products are not designed, intended, or authorized for use as components in systems intended for surgical implant into the body, or other applications intended to support or sustain life, or for any other application in which the failure of the Motorola product could create a situation where personal injury or death may occur. Should Buyer purchase or use Motorola products for any such unintended or unauthorized application, Buyer shall indemnify and hold Motorola and its officers, employees, subsidiaries, affiliates, and distributors harmless against all claims, costs, damages, and expenses, and reasonable attorney fees arising out of, directly or indirectly, any claim of personal injury or death associated with such unintended or unauthorized use, even if such claim alleges that Motorola was negligent regarding the design or manufacture of the part. Motorola and are registered trademarks of Motorola, Inc. Motorola, Inc. is an Equal Opportunity/Affirmative Action Employer.

Mfax is a trademark of Motorola, Inc.

How to reach us:

USA/EUROPE/Locations Not Listed: Motorola Literature Distribution; P.O. Box 5405, Denver, Colorado 80217. 1-303-675-2140 or 1-800-441-2447

JAPAN: Motorola Japan Ltd.; SPD, Strategic Planning Office, 141, 4-32-1 Nishi-Gotanda, Shinagawa-ku, Tokyo, Japan. 81-3-5487-8488

Customer Focus Center: 1-800-521-6274

Mfax™: RMFAX0@email.sps.mot.com – TOUCHTONE 1-602-244-6609
 Motorola Fax Back System – US & Canada ONLY 1-800-774-1848
 – http://sps.motorola.com/mfax/

ASIA/PACIFIC: Motorola Semiconductors H.K. Ltd.; Silicon Harbour Centre, 2, Dai King Street, Tai Po Industrial Estate, Tai Po, N.T., Hong Kong. 852-26668334

HOME PAGE: <http://motorola.com/sps/>



MOTOROLA

For More Information On This Product,
 Go to: www.freescale.com

MC12038A/D