

MC68HC08LK60 MC68HC908LK60

Advance Information Data Sheet

**M68HC08
Microcontrollers**

MC68HC08LK60
Rev. 1.1
09/2005

freescale.com



MC68HC08LK60

MC68HC908LK60

Advance Information Data Sheet

To provide the most up-to-date information, the revision of our documents on the World Wide Web will be the most current. Your printed copy may be an earlier revision. To verify you have the latest information available, refer to:

<http://freescale.com>

The following revision history table summarizes changes contained in this document. For your convenience, the page number designators have been linked to the appropriate location.

Revision History

| Date | Revision Level | Description | Page Number(s) |
|-----------------|----------------|--|----------------|
| September, 2005 | 1.1 | Updated to meet Freescale identity guidelines. | Throughout |

Freescale™ and the Freescale logo are trademarks of Freescale Semiconductor, Inc.
 This product incorporates SuperFlash® technology licensed from SST.

© Freescale Semiconductor, Inc., 2005. All rights reserved.

List of Chapters

| | |
|--|-----|
| Chapter 1 General Description. | 17 |
| Chapter 2 Memory Map. | 25 |
| Chapter 3 Random-Access Memory (RAM) | 35 |
| Chapter 4 FLASH Memory | 37 |
| Chapter 5 Central Processor Unit (CPU). | 47 |
| Chapter 6 System Integration Module (SIM). | 59 |
| Chapter 7 Clock Generator Module (CGMB). | 75 |
| Chapter 8 Functional Controller Module (FCM) | 95 |
| Chapter 9 Break Module | 107 |
| Chapter 10 Power-On Reset Module (POR) | 111 |
| Chapter 11 External Interrupt Module (IRQ) | 113 |
| Chapter 12 Infrared Serial Communications Interface (IrSCI). | 119 |
| Chapter 13 Serial Peripheral Interface Module (SPI) | 147 |
| Chapter 14 Alert Output Generator (ALR). | 167 |
| Chapter 15 Liquid Crystal Display Module (LCD). | 171 |
| Chapter 16 Timer Interface Module (TIM) | 181 |
| Chapter 17 Input/Output (I/O) Ports. | 199 |
| Chapter 18 Monitor ROM (MON) | 205 |
| Chapter 19 Keyboard Interrupt (KBI) Module | 213 |
| Chapter 20 Preliminary Electrical Specifications. | 217 |
| Chapter 21 Mechanical Data. | 229 |
| Chapter 22 Ordering Information. | 245 |

Table of Contents

Chapter 1 General Description

| | | |
|--------|--|----|
| 1.1 | Introduction | 17 |
| 1.2 | Features | 17 |
| 1.3 | MCU Block Diagram | 18 |
| 1.3.1 | Power Supply Pins (V_{DD} , V_{SS} , EV_{DD} , and EV_{SS}) | 20 |
| 1.3.2 | Oscillator Pins (OSC1 and OSC2) | 20 |
| 1.3.3 | External Reset Pin (\overline{RST}) | 21 |
| 1.3.4 | External Interrupt Pin ($\overline{IRQ1}$) | 21 |
| 1.3.5 | External Interrupt Pin (IRQ2) | 21 |
| 1.3.6 | Analog Ground Pin (V_{SSA}) | 21 |
| 1.3.7 | Analog Power Supply Pin (V_{DDA}) | 21 |
| 1.3.8 | External Filter Capacitor Pin (CGMXFC) | 21 |
| 1.3.9 | Port A I/O Pins (PTA7–PTA0) | 22 |
| 1.3.10 | Port B I/O Pins (PTB7–PTB0) | 22 |
| 1.3.11 | Port C I/O Pins (PTC7–PTC0) | 22 |
| 1.3.12 | SPI Master In/Slave Out (MISO) | 22 |
| 1.3.13 | SPI Master Out/Slave In (MOSI) | 22 |
| 1.3.14 | SPI Serial Clock (SPSCK) | 22 |
| 1.3.15 | SPI Slave Select (\overline{SS}) | 22 |
| 1.3.16 | SCI Receive Data (RxD) | 22 |
| 1.3.17 | SCI Transmit Data (TxD) | 22 |
| 1.3.18 | Alert Generator Output (ALERT) | 22 |
| 1.3.19 | Power Supply Pins (V_{LL} , V_{LL32} , V_{LL12} , and V_{CP4} – V_{CP1}) | 23 |
| 1.3.20 | Frontplane and Backplane Drivers (FP84–FP0, BP7–BP0) | 23 |
| 1.4 | Pin Assignments | 23 |

Chapter 2 Memory Map

| | | |
|-----|--------------------------------|----|
| 2.1 | Introduction | 25 |
| 2.2 | I/O Section | 25 |
| 2.3 | Random-Access Memory (RAM) | 25 |
| 2.4 | Memory Map | 26 |
| 2.5 | Monitor Read-Only Memory (ROM) | 34 |

Chapter 3 Random-Access Memory (RAM)

| | | |
|-----|------------------------|----|
| 3.1 | Introduction | 35 |
| 3.2 | Functional Description | 35 |

Chapter 4 FLASH Memory

| | | |
|------|---|----|
| 4.1 | Introduction | 37 |
| 4.2 | FLASH1 Functional Description | 37 |
| 4.3 | FLASH2 Functional Description | 38 |
| 4.4 | FLASH1 Control Register | 38 |
| 4.5 | FLASH2 Control Register | 40 |
| 4.6 | FLASH1 Block Protect Register | 41 |
| 4.7 | FLASH2 Block Protect Register | 42 |
| 4.8 | Block Protection | 42 |
| 4.9 | Charge Pump Frequency Control | 43 |
| 4.10 | FLASH Erase Operation | 43 |
| 4.11 | FLASH Program and Margin Read Operation | 44 |

Chapter 5 Central Processor Unit (CPU)

| | | |
|-------|---------------------------------------|----|
| 5.1 | Introduction | 47 |
| 5.2 | Features | 47 |
| 5.3 | CPU Registers | 47 |
| 5.3.1 | Accumulator | 48 |
| 5.3.2 | Index Register | 48 |
| 5.3.3 | Stack Pointer | 49 |
| 5.3.4 | Program Counter | 49 |
| 5.3.5 | Condition Code Register | 50 |
| 5.4 | Arithmetic/Logic Unit (ALU) | 51 |
| 5.5 | Low-Power Modes | 51 |
| 5.5.1 | Wait Mode | 51 |
| 5.5.2 | Stop Mode | 51 |
| 5.6 | CPU During Break Interrupts | 51 |
| 5.7 | Instruction Set Summary | 52 |
| 5.8 | Opcode Map | 57 |

Chapter 6 System Integration Module (SIM)

| | | |
|---------|---|----|
| 6.1 | Introduction | 59 |
| 6.2 | SIM Bus Clock Control and Generation | 61 |
| 6.2.1 | Bus Timing | 61 |
| 6.2.2 | Clock Startup from POR or LVI Reset | 61 |
| 6.2.3 | Clocks in Stop Mode and Wait Mode | 61 |
| 6.3 | Reset and System Initialization | 62 |
| 6.3.1 | External Pin Reset | 62 |
| 6.3.2 | Active Resets from Internal Sources | 63 |
| 6.3.2.1 | Power-On Reset | 63 |
| 6.3.2.2 | Computer Operating Properly (COP) Reset | 64 |
| 6.3.2.3 | Illegal Opcode Reset | 64 |

| | | |
|---------|---------------------------------------|----|
| 6.3.2.4 | Illegal Address Reset | 64 |
| 6.3.2.5 | Low-Voltage Inhibit (LVI) Reset | 65 |
| 6.4 | SIM Counter | 65 |
| 6.4.1 | SIM Counter During Power-On Reset | 65 |
| 6.4.2 | SIM Counter During Stop Mode Recovery | 65 |
| 6.4.3 | SIM Counter and Reset States | 65 |
| 6.5 | Exception Control | 65 |
| 6.5.1 | Interrupts | 66 |
| 6.5.1.1 | Hardware Interrupts | 68 |
| 6.5.1.2 | SWI Instruction | 68 |
| 6.5.2 | Reset | 69 |
| 6.5.3 | Break Interrupts | 69 |
| 6.5.4 | Status Flag Protection in Break Mode | 69 |
| 6.6 | Low-Power Modes | 69 |
| 6.6.1 | Wait Mode | 69 |
| 6.6.2 | Stop Mode | 70 |
| 6.7 | SIM Registers | 71 |
| 6.7.1 | SIM Break Status Register | 72 |
| 6.7.2 | SIM Reset Status Register | 73 |
| 6.7.3 | SIM Break Flag Control Register | 74 |

Chapter 7

Clock Generator Module (CGMB)

| | | |
|---------|---|----|
| 7.1 | Introduction | 75 |
| 7.2 | Features | 75 |
| 7.3 | Functional Description | 75 |
| 7.3.1 | Crystal Oscillator Circuit | 77 |
| 7.3.2 | Phase-Locked Loop Circuit (PLL) | 77 |
| 7.3.2.1 | PLL Circuits | 77 |
| 7.3.2.2 | Acquisition and Tracking Modes | 78 |
| 7.3.2.3 | Manual and Automatic PLL Bandwidth Modes | 78 |
| 7.3.2.4 | Programming the PLL | 79 |
| 7.3.2.5 | Special Programming Exceptions | 81 |
| 7.3.3 | Base Clock Selector Circuit | 81 |
| 7.3.4 | CGMB External Connections | 82 |
| 7.4 | I/O Signals | 83 |
| 7.4.1 | Crystal Amplifier Input Pin (OSC1) | 83 |
| 7.4.2 | Crystal Amplifier Output Pin (OSC2) | 83 |
| 7.4.3 | External Filter Capacitor Pin (CGMXFC) | 83 |
| 7.4.4 | PLL Analog Power Pin (V_{DDA}) | 83 |
| 7.4.5 | PLL Analog Ground Pin (V_{SSA}) | 83 |
| 7.4.6 | Oscillator Enable Signal (SIMOSCEN) | 83 |
| 7.4.7 | Crystal Output Frequency Signal (CGMXCLK) | 83 |
| 7.4.8 | CGMB Base Clock Output (CGMOUT) | 84 |
| 7.4.9 | CGMB CPU Interrupt (CGMINT) | 84 |

Table of Contents

| | | |
|-------|--|----|
| 7.5 | CGMB Registers | 84 |
| 7.5.1 | PLL Control Register | 85 |
| 7.5.2 | PLL Bandwidth Control Register | 87 |
| 7.5.3 | PLL Multiplier Select Register High | 88 |
| 7.5.4 | PLL Multiplier Select Register Low | 88 |
| 7.5.5 | PLL VCO Range Select Register | 89 |
| 7.5.6 | PLL Reference Divider Select Register | 89 |
| 7.6 | Interrupts | 90 |
| 7.7 | Wait Mode | 90 |
| 7.8 | CGMB During Break Interrupts | 90 |
| 7.9 | Acquisition/Lock Time Specifications | 91 |
| 7.9.1 | Acquisition/Lock Time Definitions | 91 |
| 7.9.2 | Parametric Influences on Reaction Time | 91 |
| 7.9.3 | Choosing a Filter Capacitor | 92 |
| 7.9.4 | Reaction Time Calculation | 93 |

Chapter 8 Functional Controller Module (FCM)

| | | |
|-------|---------------------------------------|-----|
| 8.1 | Introduction | 95 |
| 8.2 | Features | 95 |
| 8.3 | Functional Description | 95 |
| 8.4 | Module Description | 95 |
| 8.4.1 | Timebase Submodule | 96 |
| 8.4.2 | Real-Time Clock Submodule | 97 |
| 8.4.3 | COP Watchdog Timer Submodule | 98 |
| 8.5 | Interrupts | 98 |
| 8.6 | I/O Signals | 99 |
| 8.7 | Interrupt Signals (FCM, CPU, and IRQ) | 99 |
| 8.8 | Functional Controller Registers | 99 |
| 8.8.1 | Timebase Control Register | 100 |
| 8.8.2 | RTC Control Register | 102 |
| 8.8.3 | RTC Status Register | 103 |
| 8.8.4 | Chronograph Data Register | 104 |
| 8.8.5 | Seconds Data Register | 105 |
| 8.8.6 | Minutes Data Register | 105 |
| 8.8.7 | Hours Data Register | 105 |
| 8.8.8 | Alarm Minutes Register | 106 |
| 8.8.9 | Alarm Hours Register | 106 |

Chapter 9 Break Module

| | | |
|-------|---|-----|
| 9.1 | Introduction | 107 |
| 9.2 | Features | 107 |
| 9.3 | Functional Description | 107 |
| 9.3.1 | Flag Protection During Break Interrupts | 107 |
| 9.3.2 | CPU During Break Interrupts | 108 |

| | | |
|-------|---|-----|
| 9.3.3 | TIM During Break Interrupts | 108 |
| 9.3.4 | COP During Break Interrupts | 108 |
| 9.4 | Break Module Registers | 109 |
| 9.4.1 | Break Status and Control Register | 109 |
| 9.4.2 | Break Address Registers | 110 |
| 9.5 | Low-Power Modes | 110 |
| 9.5.1 | Wait Mode | 110 |
| 9.5.2 | Stop Mode | 110 |

Chapter 10 Power-On Reset Module (POR)

| | | |
|------|----------------------------------|-----|
| 10.1 | Introduction | 111 |
| 10.2 | Functional Description | 111 |

Chapter 11 External Interrupt Module (IRQ)

| | | |
|--------|--|-----|
| 11.1 | Introduction | 113 |
| 11.2 | Features | 113 |
| 11.3 | Functional Description | 113 |
| 11.3.1 | IRQ1 Pin | 115 |
| 11.3.2 | IRQ2 Pin | 116 |
| 11.4 | IRQ Module During Break Interrupts | 117 |
| 11.5 | IRQ Status and Control Register | 117 |

Chapter 12 Infrared Serial Communications Interface (IrSCI)

| | | |
|----------|---|-----|
| 12.1 | Introduction | 119 |
| 12.2 | Features | 119 |
| 12.3 | IrSCI Module Overview | 120 |
| 12.4 | Infrared Functional Description | 121 |
| 12.4.1 | Infrared Transmit Encoder | 121 |
| 12.4.2 | Infrared Receive Decoder | 121 |
| 12.5 | SCI Functional Description | 122 |
| 12.5.1 | Data Format | 124 |
| 12.5.2 | Transmitter | 124 |
| 12.5.2.1 | Character Length | 124 |
| 12.5.2.2 | Character Transmission | 124 |
| 12.5.2.3 | Break Characters | 126 |
| 12.5.2.4 | Idle Characters | 126 |
| 12.5.2.5 | Transmitter Interrupts | 126 |
| 12.5.3 | Receiver | 127 |
| 12.5.3.1 | Character Length | 128 |
| 12.5.3.2 | Character Reception | 128 |
| 12.5.3.3 | Data Sampling | 128 |
| 12.5.3.4 | Framing Errors | 130 |
| 12.5.3.5 | Baud Rate Tolerance | 130 |
| 12.5.3.6 | Receiver Wakeup | 133 |

Table of Contents

| | | |
|----------|--|-----|
| 12.5.3.7 | Receiver Interrupts | 133 |
| 12.5.3.8 | Error Interrupts | 133 |
| 12.6 | Wait Mode | 134 |
| 12.7 | SCI During Break Module Interrupts | 134 |
| 12.8 | I/O Signals | 134 |
| 12.8.1 | TxD (Transmit Data) | 134 |
| 12.8.2 | RxD (Receive Data) | 134 |
| 12.9 | I/O Registers | 135 |
| 12.9.1 | SCI Control Register 1 | 135 |
| 12.9.2 | SCI Control Register 2 | 137 |
| 12.9.3 | SCI Control Register 3 | 139 |
| 12.9.4 | SCI Status Register 1 | 140 |
| 12.9.5 | SCI Status Register 2 | 143 |
| 12.9.6 | SCI Data Register | 143 |
| 12.9.7 | SCI Baud Rate Register | 144 |
| 12.9.8 | SCI Infrared Control Register | 145 |

Chapter 13 Serial Peripheral Interface Module (SPI)

| | | |
|---------|---|-----|
| 13.1 | Introduction | 147 |
| 13.2 | Features | 147 |
| 13.3 | Functional Description | 148 |
| 13.3.1 | Master Mode | 148 |
| 13.4 | Slave Mode | 150 |
| 13.5 | Transmission Formats | 151 |
| 13.5.1 | Clock Phase and Polarity Controls | 151 |
| 13.5.2 | Transmission Format When CPHA = 0 | 151 |
| 13.5.3 | Transmission Format When CPHA = 1 | 152 |
| 13.5.4 | Transmission Initiation Latency | 153 |
| 13.6 | Queuing Transmission Data | 155 |
| 13.7 | Error Conditions | 156 |
| 13.7.1 | Overflow Error | 156 |
| 13.7.2 | Mode Fault Error | 157 |
| 13.8 | Interrupts | 158 |
| 13.9 | Resetting the SPI | 160 |
| 13.10 | Wait Mode | 160 |
| 13.11 | SPI During Break Interrupts | 160 |
| 13.12 | I/O Signals | 161 |
| 13.12.1 | Master In/Slave Out (MISO) | 161 |
| 13.12.2 | Master Out/Slave In (MOSI) | 161 |
| 13.12.3 | Serial Clock (SPSCK) | 161 |
| 13.12.4 | Slave Select (\overline{SS}) | 162 |
| 13.12.5 | Clock Ground (EV _{SS}) | 162 |
| 13.13 | I/O Registers | 163 |
| 13.13.1 | SPI Control Register | 163 |
| 13.13.2 | SPI Status and Control Register | 164 |
| 13.13.3 | SPI Data Register | 166 |

Chapter 14 Alert Output Generator (ALR)

| | | |
|--------|------------------------------------|-----|
| 14.1 | Introduction | 167 |
| 14.2 | Features | 167 |
| 14.3 | Functional Description | 167 |
| 14.3.1 | Alert Control Register | 168 |
| 14.3.2 | Sound Pressure Level Circuit | 168 |
| 14.3.3 | Alert Data Register | 169 |

Chapter 15 Liquid Crystal Display Module (LCD)

| | | |
|--------|--|-----|
| 15.1 | Introduction | 171 |
| 15.2 | Features | 171 |
| 15.3 | Functional Description | 172 |
| 15.4 | LCD Registers | 172 |
| 15.4.1 | LCD Control Register | 172 |
| 15.4.2 | LCD Address Register | 173 |
| 15.4.3 | LCD Data Register | 174 |
| 15.5 | Anti-Ghosting | 178 |
| 15.6 | Software Examples | 179 |
| 15.7 | Power Supply Pins (V_{LL} , V_{LL12} , V_{LL32} , and V_{CP1} – V_{CP4}) | 180 |

Chapter 16 Timer Interface Module (TIM)

| | | |
|----------|--|-----|
| 16.1 | Introduction | 181 |
| 16.2 | Features | 181 |
| 16.3 | Functional Description | 184 |
| 16.3.1 | Timer Counter Prescaler | 184 |
| 16.3.2 | Input Capture | 184 |
| 16.3.3 | Output Compare | 185 |
| 16.3.3.1 | Unbuffered Output Compare | 185 |
| 16.3.3.2 | Buffered Output Compare | 185 |
| 16.3.4 | Pulse-Width Modulation (PWM) | 186 |
| 16.3.4.1 | Unbuffered PWM Signal Generation | 187 |
| 16.3.4.2 | Buffered PWM Signal Generation | 187 |
| 16.3.4.3 | PWM Initialization | 188 |
| 16.4 | Interrupts | 189 |
| 16.5 | Low-Power Modes | 189 |
| 16.5.1 | Wait Mode | 189 |
| 16.5.2 | Stop Mode | 189 |
| 16.6 | TIM During Break Interrupts | 189 |
| 16.7 | I/O Signals | 190 |
| 16.7.1 | TIM Clock Pin (TCLK) | 190 |
| 16.7.2 | Timer Channel I/O Pins (TCH0–TCH3) | 190 |

Table of Contents

| | | |
|--------|--|-----|
| 16.8 | I/O Registers | 190 |
| 16.8.1 | Timer Status and Control Register | 190 |
| 16.8.2 | Timer Counter Registers | 192 |
| 16.8.3 | Timer Modulo Registers | 193 |
| 16.8.4 | Timer Channel Status and Control Registers | 193 |
| 16.8.5 | Timer Channel Registers | 197 |

Chapter 17 Input/Output (I/O) Ports

| | | |
|--------|---------------------------------|-----|
| 17.1 | Introduction | 199 |
| 17.2 | Port A | 200 |
| 17.2.1 | Port A Data Register | 200 |
| 17.2.2 | Data Direction Register A | 200 |
| 17.3 | Port B | 201 |
| 17.3.1 | Port B Data Register | 201 |
| 17.3.2 | Data Direction Register B | 202 |
| 17.4 | Port C | 203 |
| 17.4.1 | Port C Data Register | 203 |
| 17.4.2 | Data Direction Register C | 203 |

Chapter 18 Monitor ROM (MON)

| | | |
|--------|------------------------------|-----|
| 18.1 | Introduction | 205 |
| 18.2 | Features | 205 |
| 18.3 | Functional Description | 205 |
| 18.3.1 | Entering Monitor Mode | 207 |
| 18.3.2 | Data Format | 208 |
| 18.3.3 | Echoing | 208 |
| 18.3.4 | Break Signal | 208 |
| 18.3.5 | Baud Rate | 212 |

Chapter 19 Keyboard Interrupt (KBI) Module

| | | |
|--------|--|-----|
| 19.1 | Introduction | 213 |
| 19.2 | Features | 213 |
| 19.3 | Functional Description | 213 |
| 19.4 | Initialization | 215 |
| 19.5 | Wait Mode | 215 |
| 19.6 | I/O Registers | 215 |
| 19.6.1 | IRQ Status and Control Register | 215 |
| 19.6.2 | Keyboard Interrupt Enable Register | 216 |

Chapter 20 Preliminary Electrical Specifications

| | | |
|-------|---|-----|
| 20.1 | Introduction | 217 |
| 20.2 | Absolute Maximum Ratings | 217 |
| 20.3 | Functional Operating Range | 218 |
| 20.4 | Thermal Characteristics | 218 |
| 20.5 | 3.0 Volt \pm 10% DC Electrical Characteristics | 219 |
| 20.6 | 2.0 Volt \pm 10% DC Electrical Characteristics | 220 |
| 20.7 | 3.0 Volt \pm 10% Control Timing | 221 |
| 20.8 | 2.0 Volt \pm 10% Control Timing | 221 |
| 20.9 | 3.0 Volt \pm 10% Serial Peripheral Interface (SPI) Timing | 222 |
| 20.10 | 2.0 Volt \pm 10% Serial Peripheral Interface (SPI) Timing | 223 |
| 20.11 | PLL2P12M Electrical Specifications | 226 |
| 20.12 | Bus Clock PLL Acquisition/Lock Time Specifications | 226 |
| 20.13 | PLL2P12M Component Specifications | 227 |
| 20.14 | RAM Characteristics | 227 |
| 20.15 | FLASH Memory Electrical Characteristics | 227 |

Chapter 21 Mechanical Data

| | | |
|--------|---|-----|
| 21.1 | Introduction | 229 |
| 21.2 | 160 Input/Output, BGA, Standard Map, 15 x 15 Package (Case #1268) | 230 |
| 21.3 | Wire Bond Information (MCW68HC08LK60) | 231 |
| 21.3.1 | Die Pad Coordinates | 231 |
| 21.3.2 | Die Layout | 236 |
| 21.4 | Bump Wafer Information (MCCF68HC08LK60). | 237 |
| 21.4.1 | Bump Specification | 237 |
| 21.4.2 | Bumped Wafer Pad Coordinates | 238 |
| 21.4.3 | Die Feature | 243 |
| 21.4.4 | Tape and Reel Die Orientation. | 244 |

Chapter 22 Ordering Information

| | | |
|------|----------------------------|-----|
| 22.1 | Introduction | 245 |
| 22.2 | MC Order Numbers | 245 |

Chapter 1

General Description

1.1 Introduction

The MC68HC(9)08LK60 is a member of the low-cost, low-power, high-performance M68HC08 Family of 8-bit microcontroller units (MCUs). The M68HC08 Family is based on the customer-specified integrated circuit (CSIC) design strategy. All MCUs in the family use the enhanced M68HC08 central processor unit (CPU08) and are available with a variety of modules, memory sizes and types, and package types.

1.2 Features

Features of the MC68HC(9)08LK60 include:

- High-performance M68HC08 architecture
- Fully upward-compatible object code with M6805, M146805, and M68HC05 Families
- On-chip ROM/FLASH of 60 Kbytes
- 3.5 Kbytes of on-chip MCU RAM
- 24 general-purpose input/output (I/O) pins
- Serial peripheral interface module (SPI)
- Infrared serial communications interface module (IrSCI) with software selectable IrDA modulation/demodulation
- Clock generation module (CGMB)
- Functional controller module (FCM) with real-time clock
- LCD module with 85 frontplanes and 8 backplanes
- ALERT generator module
- Two external interrupt request (IRQ) pins
- 16-bit timer interface module (TIM)
- System protection features:
 - Computer operating properly (COP) reset in FCM module
 - Illegal opcode detect with reset
 - Illegal address detect with reset
- 160-pin BGA package or die
- Low-power design, fully static with wait modes
- Stop mode is disabled
- Master reset pin and power-on reset

General Description

Features of the CPU08 include:

- Enhanced HC05 programming model
- Extensive loop control functions
- 16 addressing modes, 8 more than the HC05
- 16-bit index register and stack pointer
- Fast 8 x 8 multiply instruction
- Fast 16/8 divide instruction
- Binary-coded decimal (BCD) instructions
- Optimization for controller applications
- High-level language (C language) support

NOTE

There is no direct memory access module (DMA) in MC68HC(9)08LK60. Consequently, the user should disable all the DMA functions in all modules. Only three ports (ports A, B, and C) are available; ignore all other ports mentioned. No input capture or output compare pins are available for the timer module.

1.3 MCU Block Diagram

Figure 1-1 shows the structure of the MC68HC(9)08LK60.

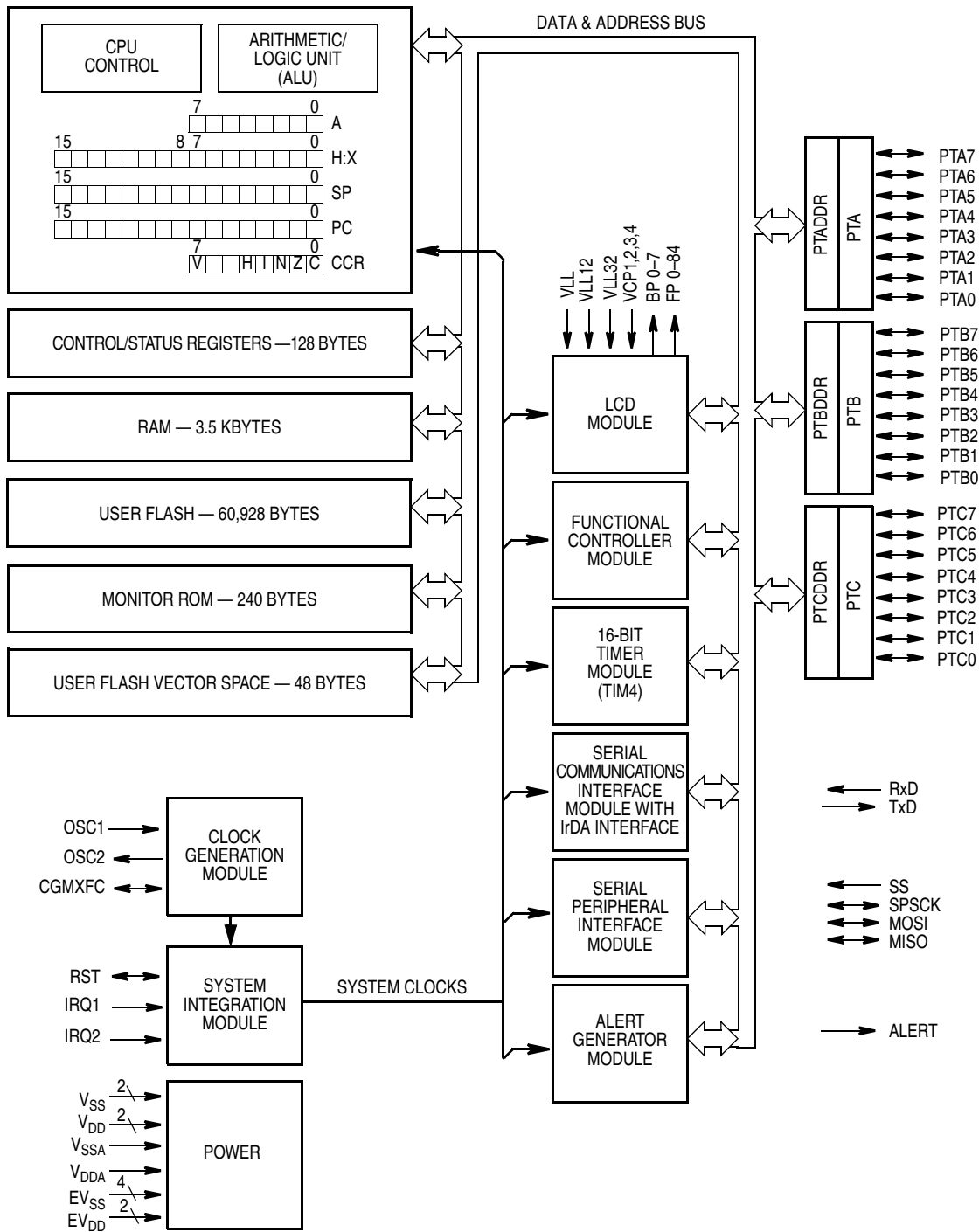

Figure 1-1. MC68HC(9)08LK60 Block Diagram

General Description

1.3.1 Power Supply Pins (V_{DD} , V_{SS} , EV_{DD} , and EV_{SS})

The two V_{DD} and two V_{SS} pins are power supply and ground pins for the digital sections of the MCU. The MCU operates from a single-power supply ranging from 2 volts ($\pm 10\%$) to 3 volts ($\pm 10\%$).

The EV_{DD} and EV_{SS} pins are power supply and ground pins for the I/O section of the MCU.

Very fast signal transitions on the MCU pins place high, short-duration current demands on the power supply. To prevent noise problems, take special care to provide good power supply bypassing at the MCU as shown in [Figure 1-2](#). Place the C1 bypass capacitor as close to the MCU as possible. Use a high-frequency-response ceramic capacitor for C1. C2 is an optional bulk current bypass capacitor for use in applications that require the port pins to source high current levels.

EV_{SS} pin is also the ground return pin for the serial clock in the serial peripheral interface module (SPI). It enables the user to implement a coplanar transmission line for the SPI clock on printed circuit boards (PCBs) with no ground plane. EV_{SS} can help reduce radiated radio frequency (RF) emissions by controlling trace impedance and minimizing radiating loop area. See [Chapter 13 Serial Peripheral Interface Module \(SPI\)](#) for more information.

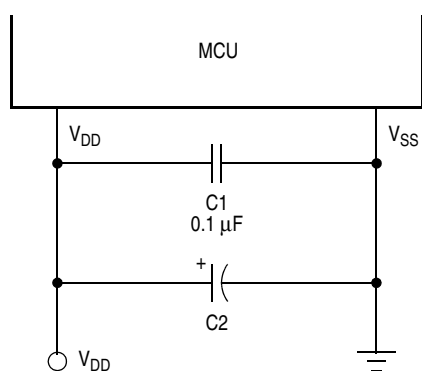

Figure 1-2. Power Supply Bypassing

NOTE

Component values shown represent typical applications.

1.3.2 Oscillator Pins (OSC1 and OSC2)

The OSC1 and OSC2 pins are the crystal connections for the on-chip oscillator. [Figure 1-3](#) shows a typical crystal oscillator circuit for a parallel resonant crystal. Follow the crystal supplier's recommendations, as the crystal parameters determine the external component values required to provide reliable startup and maximum stability. The load capacitance values used in the oscillator circuit design should include all stray layout capacitances. To minimize output distortion and radio frequency (RF) emissions, mount the crystal and capacitors as close as possible to the pins. Pay special attention to minimizing the length of the oscillator load capacitors' ground return path.

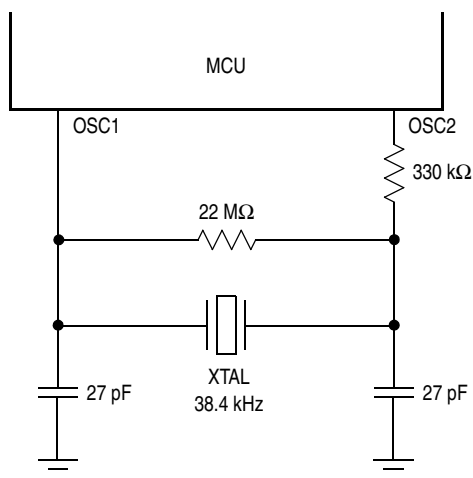

Figure 1-3. Crystal Connections

NOTE

Component values shown represent typical applications. Follow the crystal manufacturer's recommendations.

1.3.3 External Reset Pin ($\overline{\text{RST}}$)

A logic 0 on the $\overline{\text{RST}}$ pin forces the MCU to a known startup state. $\overline{\text{RST}}$ is bidirectional, allowing a reset of the entire system. It is driven low when any internal reset source is asserted. See [Chapter 6 System Integration Module \(SIM\)](#) for more information.

1.3.4 External Interrupt Pin ($\overline{\text{IRQ1}}$)

$\overline{\text{IRQ1}}$ is an asynchronous external interrupt pin. See [Chapter 6 System Integration Module \(SIM\)](#) and [Chapter 11 External Interrupt Module \(IRQ\)](#) for more information.

1.3.5 External Interrupt Pin ($\overline{\text{IRQ2}}$)

$\overline{\text{IRQ2}}$ is an asynchronous external interrupt pin. See [Chapter 6 System Integration Module \(SIM\)](#) and [Chapter 11 External Interrupt Module \(IRQ\)](#) for more information.

1.3.6 Analog Ground Pin (V_{SSA})

The V_{SSA} analog ground pin is used only for the ground connections for the analog sections of the clock generator module (CGM) and should be decoupled as per the V_{SS} digital ground pin. See [7.1 Introduction](#) for more information.

1.3.7 Analog Power Supply Pin (V_{DDA})

V_{DDA} is the power supply pin for the analog portion of the clock generator module (CGM). See [7.1 Introduction](#) for more information.

1.3.8 External Filter Capacitor Pin (CGMXFC)

CGMXFC is an external filter capacitor connection for the CGM. See [7.1 Introduction](#) for more information.

General Description

1.3.9 Port A I/O Pins (PTA7–PTA0)

PTA7–PTA0 are general-purpose bidirectional I/O port pins. See [Chapter 17 Input/Output \(I/O\) Ports](#) for more information.

1.3.10 Port B I/O Pins (PTB7–PTB0)

PTB7–PTB0 are general-purpose bidirectional I/O port pins. See [Chapter 17 Input/Output \(I/O\) Ports](#) for more information.

1.3.11 Port C I/O Pins (PTC7–PTC0)

PTC7–PTC0 are general-purpose bidirectional I/O port pins. See [Chapter 17 Input/Output \(I/O\) Ports](#) for more information.

1.3.12 SPI Master In/Slave Out (MISO)

MISO is used in the SPI to receive/transmit data in the SPI module. See [Chapter 13 Serial Peripheral Interface Module \(SPI\)](#) for more information.

1.3.13 SPI Master Out/Slave In (MOSI)

MOSI is used in the SPI to receive/transmit data in the SPI module. See [Chapter 13 Serial Peripheral Interface Module \(SPI\)](#) for more information.

1.3.14 SPI Serial Clock (SPSCK)

SPSCK is the serial clock of the SPI that synchronizes data transmission between master and slave devices. See [Chapter 13 Serial Peripheral Interface Module \(SPI\)](#) for more information.

1.3.15 SPI Slave Select (\overline{SS})

\overline{SS} is the slave select of the SPI that indicate that the slave is enabled to receive data when the pin is at logic 0. See [Chapter 13 Serial Peripheral Interface Module \(SPI\)](#) for more information.

1.3.16 SCI Receive Data (RxD)

The RxD pin is serial data input to the SCI receiver. See [Chapter 12 Infrared Serial Communications Interface \(IrSCI\)](#) for more information.

1.3.17 SCI Transmit Data (TxD)

The TxD pin is the serial data output from the SCI transmitter. See [Chapter 12 Infrared Serial Communications Interface \(IrSCI\)](#) for more information.

1.3.18 Alert Generator Output (ALERT)

This is the output from the alert generator module. See [Chapter 14 Alert Output Generator \(ALR\)](#) for more information.

1.3.19 Power Supply Pins (V_{LL} , V_{LL32} , V_{LL12} , and V_{CP4} – V_{CP1})

These are power supply pins for the LCD (liquid crystal display) voltage converter. These pins should be connected in a certain configuration in order for the charge pump to work correctly. See [Chapter 15 Liquid Crystal Display Module \(LCD\)](#) for detailed hookup configuration.

1.3.20 Frontplane and Backplane Drivers (FP84–FP0, BP7–BP0)

These are frontplane (FP84–FP0) and backplane (BP7–BP0) drivers for an LCD display. See [Chapter 15 Liquid Crystal Display Module \(LCD\)](#) for more information.

1.4 Pin Assignments

The MC68HC(9)08LK60 is available in a 160-pin BGA package. The pin assignments for this package are shown in [Figure 1-4](#).

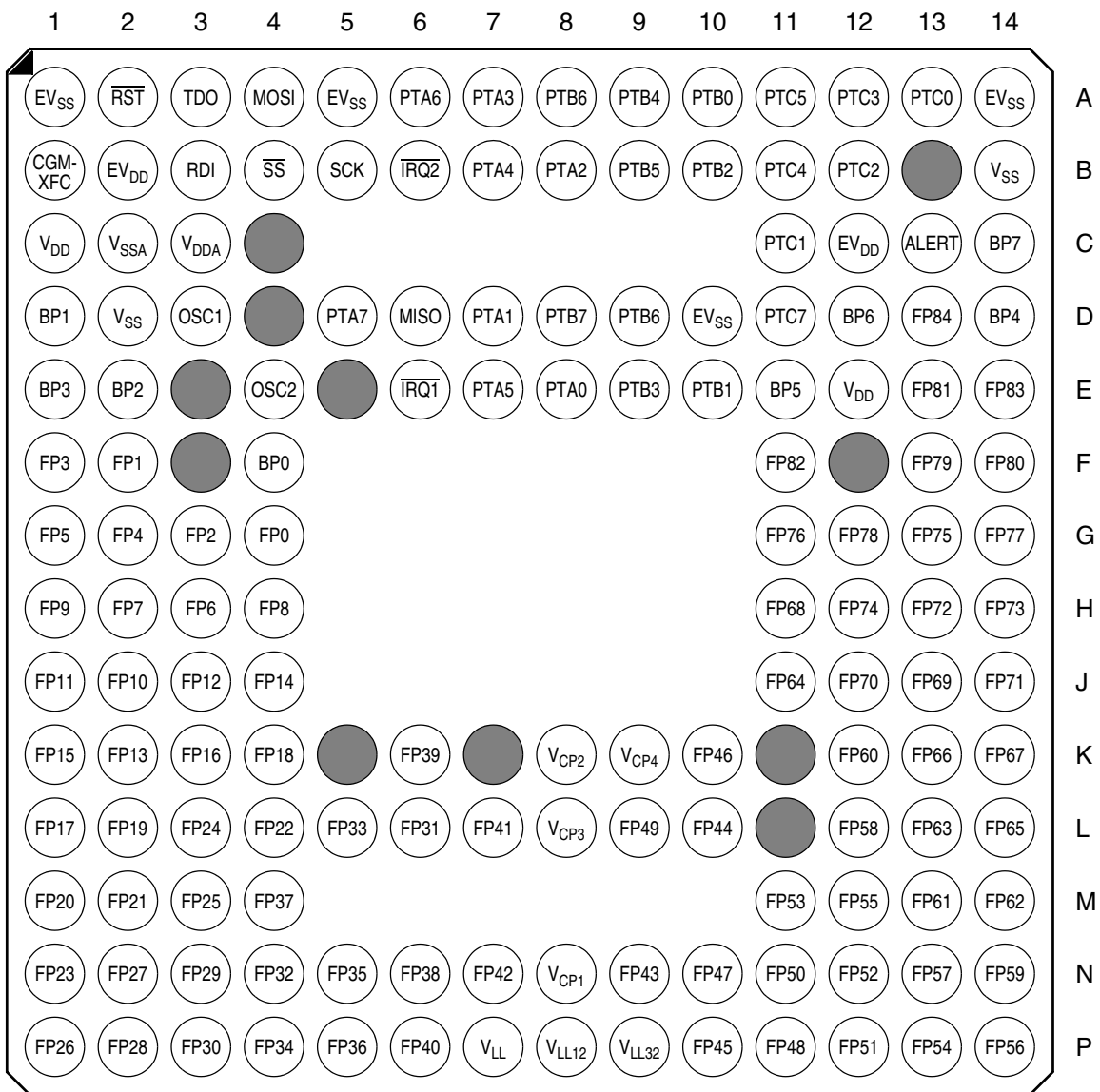

Figure 1-4. 160-Pin BGA Pin Assignments

Chapter 2

Memory Map

2.1 Introduction

The central processor unit (CPU08) can address 64 Kbytes of memory space. The memory map, shown in [Figure 2-1](#), includes:

- 60 Kbytes of FLASH
- 3.5 Kbytes of RAM
- 48 bytes of user-defined vectors
- 240 bytes of monitor ROM

2.2 I/O Section

Addresses \$0000–\$003F, shown in [Figure 2-2](#), contain most of the control, status, and data registers. Additional input/output (I/O) registers ([Figure 2-3](#)) have these addresses:

- \$FE00, SIM break status register (SBSR)
- \$FE01, SIM reset status register (SRSR)
- \$FE03, SIM break flag control register (SBFCR)
- \$FE09, FLASH2 control register (FL2CR)
- \$FE08, FLASH1 control register (FL1CR)
- \$FE0C and \$FE0D, break address registers (BRKH and BRKL)
- \$FE0E, break status and control register (BRKSCR)

2.3 Random-Access Memory (RAM)

The 3584 addresses from \$0040–\$0E3F are RAM locations. The location of the stack RAM is programmable. The 16-bit stack pointer allows the stack to be anywhere in RAM, allowing all page zero locations to be used for I/O control and user data or code. Within page zero there are 192 bytes of RAM. When the stack pointer is moved from its reset location at \$00FF, direct addressing mode instructions can access all page zero RAM locations efficiently. Page zero RAM, therefore, provides ideal locations for frequently accessed global variables.

Before processing an interrupt, the CPU uses five bytes of the stack to save the contents of the CPU registers.

NOTE

To maintain M6805 compatibility, the upper byte of the index register (H) is not stacked automatically. If the interrupt service routine modifies H, then the user must stack and unstack H using the PSHH and PULH instructions.

During a subroutine call, the CPU uses two bytes of the stack to store the return address. The stack pointer decrements during pushes and increments during pulls.

NOTE

Be careful when using nested subroutines or multiple interrupt levels. The CPU may overwrite data in the RAM during a subroutine or during the interrupt stacking.

2.4 Memory Map

See [Figure 2-1](#), [Figure 2-2](#), [Figure 2-3](#), and [Figure 2-4](#).

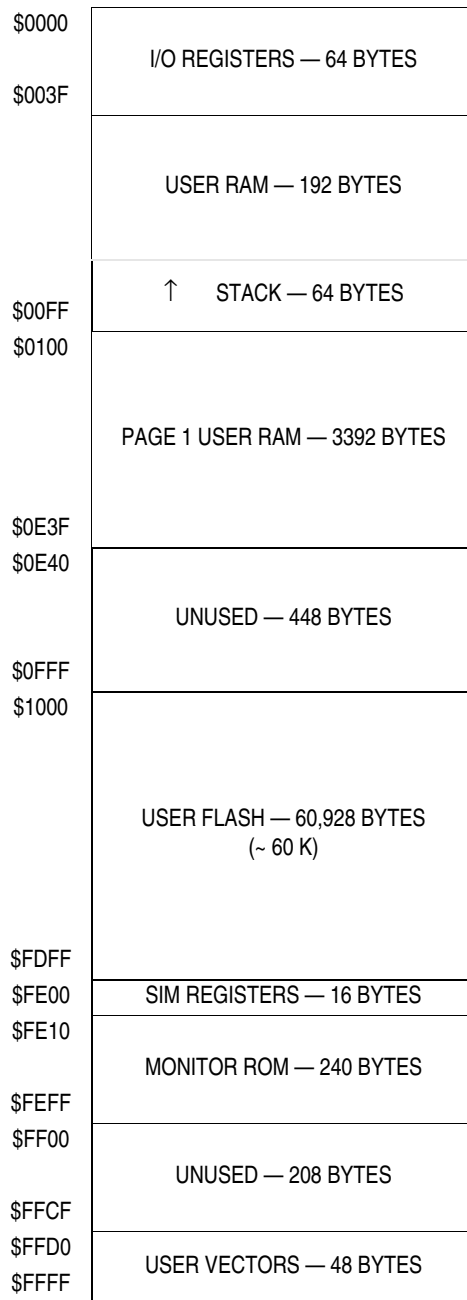

Figure 2-1. Memory Map

| Addr. | Register Name | Bit 7 | 6 | 5 | 4 | 3 | 2 | 1 | Bit 0 | |
|--------|--|--------|---------------------|--------------------|------------------|-------|-------|-------|-------|-------|
| \$0000 | Port A Data Register (PTA) | Read: | PTA7 | PTA6 | PTA5 | PTA4 | PTA3 | PTA2 | PTA1 | PTA0 |
| | | Write: | | | | | | | | |
| | | Reset: | Unaffected by reset | | | | | | | |
| \$0001 | Port B Data Register (PTB) | Read: | PTB7 | PTB6 | PTB5 | PTB4 | PTB3 | PTB2 | PTB1 | PTB0 |
| | | Write: | | | | | | | | |
| | | Reset: | Unaffected by reset | | | | | | | |
| \$0002 | Port C Data Register (PTC) | Read: | PTC7 | PTC6 | PTC5 | PTC4 | PTC3 | PTC2 | PTC1 | PTC0 |
| | | Write: | | | | | | | | |
| | | Reset: | Unaffected by reset | | | | | | | |
| \$0003 | Keyboard Interrupt Enable Register (KBIER) | Read: | KBIE7 | KBIE6 | KBIE5 | KBIE4 | KBIE3 | KBIE2 | KBIE1 | KBIE0 |
| | | Write: | | | | | | | | |
| | | Reset: | 0 | 0 | 0 | 0 | 0 | 0 | 0 | 0 |
| \$0004 | Data Direction Register A (DDRA) | Read: | DDRA7 | DDRA6 | DDRA5 | DDRA4 | DDRA3 | DDRA2 | DDRA1 | DDRA0 |
| | | Write: | | | | | | | | |
| | | Reset: | 0 | 0 | 0 | 0 | 0 | 0 | 0 | 0 |
| \$0005 | Data Direction Register B (DDRB) | Read: | DDRB7 | DDRB6 | DDRB5 | DDRB4 | DDRB3 | DDRB2 | DDRB1 | DDRB0 |
| | | Write: | | | | | | | | |
| | | Reset: | 0 | 0 | 0 | 0 | 0 | 0 | 0 | 0 |
| \$0006 | Data Direction Register C (DDRC) | Read: | DDRC7 | DDRC6 | DDRC5 | DDRC4 | DDRC3 | DDRC2 | DDRC1 | DDRC0 |
| | | Write: | | | | | | | | |
| | | Reset: | 0 | 0 | 0 | 0 | 0 | 0 | 0 | 0 |
| \$0007 | PLL Control Register (PCTL) | Read: | PLLIE | PLL \overline{F} | PLLON | BCS | PRE1 | PRE0 | VPR1 | VPR0 |
| | | Write: | | | | | | | | |
| | | Reset: | 0 | 0 | 1 | 0 | 1 | 1 | 1 | 1 |
| \$0008 | PLL Bandwidth Control Register (PBWC) | Read: | AUTO | LOCK | \overline{ACQ} | 0 | 0 | 0 | 0 | R |
| | | Write: | | | | | | | | |
| | | Reset: | 0 | 0 | 0 | 0 | 0 | 0 | 0 | 0 |
| \$0009 | PLL Multiplier Select Register High (PMSH) | Read: | 0 | 0 | 0 | 0 | MUL11 | MUL10 | MUL9 | MUL8 |
| | | Write: | | | | | | | | |
| | | Reset: | 0 | 0 | 0 | 0 | 0 | 0 | 0 | 0 |
| \$000A | PLL Multiplier Select Register Low (PMSL) | Read: | MUL7 | MUL6 | MUL5 | MUL4 | MUL3 | MUL2 | MUL1 | MUL0 |
| | | Write: | | | | | | | | |
| | | Reset: | 0 | 1 | 0 | 0 | 0 | 0 | 0 | 0 |
| \$000B | PLL VCO Range Select Register (PVRS) | Read: | VRS7 | VRS6 | VRS5 | VRS4 | VRS3 | VRS2 | VRS1 | VRS0 |
| | | Write: | | | | | | | | |
| | | Reset: | 0 | 1 | 0 | 0 | 0 | 0 | 0 | 0 |

= Unimplemented
 U = Undetermined
 X = Indeterminate

Figure 2-2. Control, Status, and Data Registers (Sheet 1 of 5)

Memory Map

| Addr. | Register Name | Bit 7 | 6 | 5 | 4 | 3 | 2 | 1 | Bit 0 | |
|--------|--|--------|---------------------------|-------|--------|-------|------|--------|-------|-------|
| \$000C | PLL Reference Divider Select Register (PRDS) | Read: | 0 | 0 | 0 | 0 | RDS3 | RDS2 | RDS1 | RDS0 |
| | | Write: | | | | | | | | |
| | | Reset: | 0 | 0 | 0 | 0 | 0 | 0 | 0 | 1 |
| \$000D | SPI Control Register (SPCR) | Read: | SPRIE | DMAS | SPMSTR | CPOL | CPHA | SPWOM | SPE | SPTIE |
| | | Write: | | | | | | | | |
| | | Reset: | 0 | 0 | 1 | 0 | 1 | 0 | 0 | 0 |
| \$000E | SPI Status and Control Register (SPSCR) | Read: | SPRF | ERRIE | OVRF | MODF | SPTE | MODFEN | SPR1 | SPR0 |
| | | Write: | | | | | | | | |
| | | Reset: | 0 | 0 | 0 | 0 | 1 | 0 | 0 | 0 |
| \$000F | SPI Data Register (SPDR) | Read: | R7 | R6 | R5 | R4 | R3 | R2 | R1 | R0 |
| | | Write: | T7 | T6 | T5 | T4 | T3 | T2 | T1 | T0 |
| | | Reset: | Indeterminate after reset | | | | | | | |
| \$0010 | Unimplemented | | | | | | | | | |
| \$0011 | Alert Control Register (ALCR) | Read: | 0 | 0 | 0 | 0 | AL3 | AL2 | AL1 | AL0 |
| | | Write: | | | | | | | | |
| | | Reset: | 0 | 0 | 0 | 0 | 0 | 0 | 0 | 0 |
| \$0012 | Alert Data Register (ALDR) | Read: | SPL7 | SPL6 | SPL5 | SPL4 | SPL3 | SPL2 | SPL1 | SPL0 |
| | | Write: | | | | | | | | |
| | | Reset: | 0 | 0 | 0 | 0 | 0 | 0 | 0 | 0 |
| \$0013 | SCI Control Register 1 (SCC1) | Read: | LOOPS | ENSCI | 0 | M | WAKE | ILTY | PEN | PTY |
| | | Write: | | | | | | | | |
| | | Reset: | 0 | 0 | 0 | 0 | 0 | 0 | 0 | 0 |
| \$0014 | SCI Control Register 2 (SCC2) | Read: | SCTIE | TCIE | SCRIE | ILIE | TE | RE | RWU | SBK |
| | | Write: | | | | | | | | |
| | | Reset: | 0 | 0 | 0 | 0 | 0 | 0 | 0 | 0 |
| \$0015 | SCI Control Register 3 (SCC3) | Read: | R8 | T8 | DMARE | DMATE | ORIE | NEIE | FEIE | PEIE |
| | | Write: | | | | | | | | |
| | | Reset: | U | U | 0 | 0 | 0 | 0 | 0 | 0 |
| \$0016 | SCI Status Register 1 (SCS1) | Read: | SCTE | TC | SCRf | IDLE | OR | NF | FE | PE |
| | | Write: | | | | | | | | |
| | | Reset: | 1 | 1 | 0 | 0 | 0 | 0 | 0 | 0 |
| \$0017 | SCI Status Register 2 (SCS2) | Read: | | | | | | | BKF | RPF |
| | | Write: | | | | | | | | |
| | | Reset: | 0 | 0 | 0 | 0 | 0 | 0 | 0 | 0 |
| \$0018 | SCI Data Register (SCDR) | Read: | R7 | R6 | R5 | R4 | R3 | R2 | R1 | R0 |
| | | Write: | T7 | T6 | T5 | T4 | T3 | T2 | T1 | T0 |
| | | Reset: | Unaffected by reset | | | | | | | |

= Unimplemented
 U = Undetermined
 X = Indeterminate

Figure 2-2. Control, Status, and Data Registers (Sheet 2 of 5)

| Addr. | Register Name | Bit 7 | 6 | 5 | 4 | 3 | 2 | 1 | Bit 0 | |
|--------|--|---------------|--------|--------|--------|--------|---------|--------|--------|-------|
| \$0019 | SCI Baud Rate Register (SCBR) | Read: | 0 | 0 | 0 | 0 | 0 | SCR2 | SCR1 | SCR0 |
| | | Write: | | | | | | | | |
| | | Reset: | 0 | 0 | 0 | 0 | 0 | 0 | 0 | 0 |
| \$001A | LCD Control Register (LCDCR) | Read: | DUTY1 | DUTY0 | AGON | DSMIN | MOTMD | 0 | 0 | 0 |
| | | Write: | | | | | | | | |
| | | Reset: | 0 | 0 | 0 | 0 | 0 | 0 | 0 | 0 |
| \$001B | LCD Address Register (LCDAR) | Read: | Bit 7 | Bit 6 | Bit 5 | Bit 4 | Bit 3 | Bit 2 | Bit 1 | Bit 0 |
| | | Write: | | | | | | | | |
| | | Reset: | 0 | 0 | 0 | 0 | 0 | 0 | 0 | 0 |
| \$001C | LCD Data Register (LCDDR) | Read: | BP7 | BP6 | BP5 | BP4 | BP3 | BP2 | BP1 | BP0 |
| | | Write: | | | | | | | | |
| | | Reset: | 0 | 0 | 0 | 0 | 0 | 0 | 0 | 0 |
| \$001D | IRQ Status and Control Register (ISCR) | Read: | PIN2 | 0 | IMASK2 | MODE2 | IRQ2DIS | 0 | IMASK1 | MODE1 |
| | | Write: | | ACK2 | | | | ACK1 | | |
| | | Reset: | 0 | 0 | 0 | 0 | 0 | 0 | 0 | 0 |
| \$001E | SCI Infrared Control Register (SCIRCR) | Read: | 0 | 0 | 0 | 0 | 0 | TNP1 | TNP0 | IREN |
| | | Write: | | | | | | | | |
| | | Reset: | 0 | 0 | 0 | 0 | 0 | 0 | 0 | 0 |
| \$001F | | Unimplemented | | | | | | | | |
| \$0020 | TIM Status and Control Register (TSC) | Read: | TOF | TOIE | TSTOP | 0 | 0 | PS2 | PS1 | PS0 |
| | | Write: | 0 | | | TRST | | | | |
| | | Reset: | 0 | 0 | 0 | 0 | 0 | 0 | 0 | 0 |
| \$0021 | | Unimplemented | | | | | | | | |
| \$0022 | TIM Counter Register High (TCNTH) | Read: | Bit 15 | Bit 14 | Bit 13 | Bit 12 | Bit 11 | Bit 10 | Bit 9 | Bit 8 |
| | | Write: | | | | | | | | |
| | | Reset: | 0 | 0 | 0 | 0 | 0 | 0 | 0 | 0 |
| \$0023 | TIM Counter Register Low (TCNTL) | Read: | Bit 7 | Bit 6 | Bit 5 | Bit 4 | Bit 3 | Bit 2 | Bit 1 | Bit 0 |
| | | Write: | | | | | | | | |
| | | Reset: | 0 | 0 | 0 | 0 | 0 | 0 | 0 | 0 |
| \$0024 | TIM Counter Modulo Register High (TMODH) | Read: | Bit 15 | Bit 14 | Bit 13 | Bit 12 | Bit 11 | Bit 10 | Bit 9 | Bit 8 |
| | | Write: | | | | | | | | |
| | | Reset: | 0 | 0 | 0 | 0 | 0 | 0 | 0 | 0 |
| \$0025 | TIM Counter Modulo Register Low (TMODL) | Read: | Bit 7 | Bit 6 | Bit 5 | Bit 4 | Bit 3 | Bit 2 | Bit 1 | Bit 0 |
| | | Write: | | | | | | | | |
| | | Reset: | 0 | 0 | 0 | 0 | 0 | 0 | 0 | 0 |

= Unimplemented
 U = Undetermined
 X = Indeterminate

Figure 2-2. Control, Status, and Data Registers (Sheet 3 of 5)

Memory Map

| Addr. | Register Name | Bit 7 | 6 | 5 | 4 | 3 | 2 | 1 | Bit 0 | |
|--------|--|--------|--------|--------|--------|--------|--------|--------|-------|--------|
| \$0026 | TIM Channel 0 Status and Control Register (TSC0) | Read: | CH0F | CH0IE | MS0B | MS0A | ELS0B | ELS0A | TOV0 | CH0MAX |
| | | Write: | 0 | | | | | | | |
| | | Reset: | 0 | 0 | 0 | 0 | 0 | 0 | 0 | 0 |
| \$0027 | TIM Channel 0 Register High (TCH0H) | Read: | Bit 15 | Bit 14 | Bit 13 | Bit 12 | Bit 11 | Bit 10 | Bit 9 | Bit 8 |
| | | Write: | Bit 15 | Bit 14 | Bit 13 | Bit 12 | Bit 11 | Bit 10 | Bit 9 | Bit 8 |
| | | Reset: | 0 | 0 | 0 | 0 | 0 | 0 | 0 | 0 |
| \$0028 | TIM Channel 0 Register Low (TCH0L) | Read: | Bit 7 | Bit 6 | Bit 5 | Bit 4 | Bit 3 | Bit 2 | Bit 1 | Bit 0 |
| | | Write: | Bit 7 | Bit 6 | Bit 5 | Bit 4 | Bit 3 | Bit 2 | Bit 1 | Bit 0 |
| | | Reset: | 0 | 0 | 0 | 0 | 0 | 0 | 0 | 0 |
| \$0029 | TIM Channel 1 Status and Control Register (TSC1) | Read: | CH1F | CH1IE | 0 | MS1A | ELS1B | ELS1A | TOV1 | CH1MAX |
| | | Write: | 0 | | | | | | | |
| | | Reset: | 0 | 0 | 0 | 0 | 0 | 0 | 0 | 0 |
| \$002A | TIM Channel 1 Register High (TCH1H) | Read: | Bit 15 | Bit 14 | Bit 13 | Bit 12 | Bit 11 | Bit 10 | Bit 9 | Bit 8 |
| | | Write: | Bit 15 | Bit 14 | Bit 13 | Bit 12 | Bit 11 | Bit 10 | Bit 9 | Bit 8 |
| | | Reset: | 0 | 0 | 0 | 0 | 0 | 0 | 0 | 0 |
| \$002B | TIM Channel 1 Register Low (TCH1L) | Read: | Bit 7 | Bit 6 | Bit 5 | Bit 4 | Bit 3 | Bit 2 | Bit 1 | Bit 0 |
| | | Write: | Bit 7 | Bit 6 | Bit 5 | Bit 4 | Bit 3 | Bit 2 | Bit 1 | Bit 0 |
| | | Reset: | 0 | 0 | 0 | 0 | 0 | 0 | 0 | 0 |
| \$002C | TIM Channel 2 Status and Control Register (TSC2) | Read: | CH2F | CH2IE | MS2B | MS2A | ELS2B | ELS2A | TOV2 | CH2MAX |
| | | Write: | 0 | | | | | | | |
| | | Reset: | 0 | 0 | 0 | 0 | 0 | 0 | 0 | 0 |
| \$002D | TIM Channel 2 Register High (TCH2H) | Read: | Bit 15 | Bit 14 | Bit 13 | Bit 12 | Bit 11 | Bit 10 | Bit 9 | Bit 8 |
| | | Write: | Bit 15 | Bit 14 | Bit 13 | Bit 12 | Bit 11 | Bit 10 | Bit 9 | Bit 8 |
| | | Reset: | 0 | 0 | 0 | 0 | 0 | 0 | 0 | 0 |
| \$002E | TIM Channel 2 Register Low (TCH2L) | Read: | Bit 7 | Bit 6 | Bit 5 | Bit 4 | Bit 3 | Bit 2 | Bit 1 | Bit 0 |
| | | Write: | Bit 7 | Bit 6 | Bit 5 | Bit 4 | Bit 3 | Bit 2 | Bit 1 | Bit 0 |
| | | Reset: | 0 | 0 | 0 | 0 | 0 | 0 | 0 | 0 |
| \$002F | TIM Channel 3 Status and Control Register (TSC3) | Read: | CH3F | CH3IE | 0 | MS3A | ELS3B | ELS3A | TOV3 | CH3MAX |
| | | Write: | 0 | | | | | | | |
| | | Reset: | 0 | 0 | 0 | 0 | 0 | 0 | 0 | 0 |
| \$0030 | TIM Channel 3 Register High (TCH3H) | Read: | Bit 15 | Bit 14 | Bit 13 | Bit 12 | Bit 11 | Bit 10 | Bit 9 | Bit 8 |
| | | Write: | Bit 15 | Bit 14 | Bit 13 | Bit 12 | Bit 11 | Bit 10 | Bit 9 | Bit 8 |
| | | Reset: | 0 | 0 | 0 | 0 | 0 | 0 | 0 | 0 |
| \$0031 | TIM Channel 3 Register Low (TCH3L) | Read: | Bit 7 | Bit 6 | Bit 5 | Bit 4 | Bit 3 | Bit 2 | Bit 1 | Bit 0 |
| | | Write: | Bit 7 | Bit 6 | Bit 5 | Bit 4 | Bit 3 | Bit 2 | Bit 1 | Bit 0 |
| | | Reset: | 0 | 0 | 0 | 0 | 0 | 0 | 0 | 0 |
| \$0032 | FLASH2 Block Protect Register (FL2BPR) | Read: | | | | | | | | |
| | | Write: | | | | | BPR3 | BPR2 | BPR1 | BPR0 |
| | | Reset: | X | X | X | X | 1 | 1 | 1 | 1 |

= Unimplemented
 U = Undetermined
 X = Indeterminate

Figure 2-2. Control, Status, and Data Registers (Sheet 4 of 5)

| Addr. | Register Name | Bit 7 | 6 | 5 | 4 | 3 | 2 | 1 | Bit 0 | |
|--------|--|---------------|-------|-------|-------|-------|-------|-------|-------|-------|
| \$0033 | FLASH1 Block Protect Register (FL1BPR) | Read: | | | | | | | | |
| | | Write: | | | | | BPR3 | BPR2 | BPR1 | BPR0 |
| | | Reset: | X | X | X | X | 1 | 1 | 1 | 1 |
| \$0034 | | Unimplemented | | | | | | | | |
| \$0035 | Timebase Control Register (TBCR) | Read: | RTCE | 0 | CHRC | CRS1 | CRS0 | R | TB2X | TB0 |
| | | Write: | | TBCLR | | | | | | |
| | | Reset: | 0 | 0 | 0 | 0 | 0 | 0 | 0 | 0 |
| \$0036 | RTC Control Register (RTCCR) | Read: | HRIE | MINIE | SECIE | CHRIE | CHRCE | ALIEN | PRQ1 | PRQ0 |
| | | Write: | | | | | | | | |
| | | Reset: | 0 | 0 | 0 | 0 | 0 | 0 | 0 | 0 |
| \$0037 | RTC Status Register (RTCSR) | Read: | 0 | 0 | PRQF | HORF | MINF | SECF | AFLG | CHRF |
| | | Write: | | | | | | | | |
| | | Reset: | 0 | 0 | 0 | 0 | 0 | 0 | 0 | 0 |
| \$0038 | Chronograph Data Register (CHRDR) | Read: | Bit 7 | Bit 6 | Bit 5 | Bit 4 | Bit 3 | Bit 2 | Bit 1 | Bit 0 |
| | | Write: | | | | | | | | |
| | | Reset: | 0 | 0 | 0 | 0 | 0 | 0 | 0 | 0 |
| \$0039 | RTC Seconds Register (SECR) | Read: | 0 | 0 | SEC5 | SEC4 | SEC3 | SEC2 | SEC1 | SEC0 |
| | | Write: | | | | | | | | |
| | | Reset: | 0 | 0 | 0 | 0 | 0 | 0 | 0 | 0 |
| \$003A | RTC Minutes Register (MINR) | Read: | 0 | 0 | MIN5 | MIN4 | MIN3 | MIN2 | MIN1 | MIN0 |
| | | Write: | | | | | | | | |
| | | Reset: | 0 | 0 | 0 | 0 | 0 | 0 | 0 | 0 |
| \$003B | RTC Hours Register (HORR) | Read: | 0 | 0 | 0 | HOR4 | HOR3 | HOR2 | HOR1 | HOR0 |
| | | Write: | | | | | | | | |
| | | Reset: | 0 | 0 | 0 | 0 | 0 | 0 | 0 | 0 |
| \$003C | Alarm Minutes Register (ALMR) | Read: | 0 | 0 | AM5 | AM4 | AM3 | AM2 | AM1 | AM0 |
| | | Write: | | | | | | | | |
| | | Reset: | 0 | 0 | 0 | 0 | 0 | 0 | 0 | 0 |
| \$003D | Alarm Hours Register (ALHR) | Read: | 0 | 0 | 0 | AH4 | AH3 | AH2 | AH1 | AH0 |
| | | Write: | | | | | | | | |
| | | Reset: | 0 | 0 | 0 | 0 | 0 | 0 | 0 | 0 |
| \$003E | | Unimplemented | | | | | | | | |
| \$003F | | Unimplemented | | | | | | | | |

= Unimplemented
 U = Undetermined
 X = Indeterminate

Figure 2-2. Control, Status, and Data Registers (Sheet 5 of 5)

Memory Map

| Addr. | Register Name | Bit 7 | 6 | 5 | 4 | 3 | 2 | 1 | Bit 0 | |
|--|---|---------------|--------|--------|--------|--------|--------|--------|-------|-------|
| \$FE00 | SIM Break Status Register (SBSR) | Read: | R | R | R | R | R | SBSW | R | |
| | | Write: | | | | | | Note 1 | | |
| | | Reset: | | | | | | 0 | | |
| Note 1. Writing a logic 0 clears SBSW. | | | | | | | | | | |
| \$FE01 | SIM Reset Status Register (SRSR) | Read: | POR | PIN | COP | ILOP | ILAD | 0 | LVI | 0 |
| | | Write: | | | | | | | | |
| | | Reset: | 1 | 0 | 0 | 0 | 0 | 0 | 0 | 0 |
| \$FE02 | | Reserved | | | | | | | | |
| \$FE03 | SIM Break Flag Control Register (SBFCR) | Read: | BCFE | R | R | R | R | R | R | R |
| | | Write: | | | | | | | | |
| | | Reset: | 0 | | | | | | | |
| \$FE04 | | Reserved | | | | | | | | |
| \$FE05 | | Reserved | | | | | | | | |
| \$FE06 | | Reserved | | | | | | | | |
| \$FE07 | | Reserved | | | | | | | | |
| \$FE08 | | Reserved | | | | | | | | |
| \$FE09 | FLASH2 Control Register (FL2CR) | Read: | FDIV1 | FDIV0 | BLK1 | BLK0 | HVEN | MARG | ERASE | PGM |
| | | Write: | | | | | | | | |
| | | Reset: | 0 | 0 | 0 | 0 | 0 | 0 | 0 | 0 |
| \$FE0A | | Reserved | | | | | | | | |
| \$FE0B | FLASH1 Control Register (FL1CR) | Read: | FDIV1 | FDIV0 | BLK1 | BLK0 | HVEN | MARG | ERASE | PGM |
| | | Write: | | | | | | | | |
| | | Reset: | 0 | 0 | 0 | 0 | 0 | 0 | 0 | 0 |
| \$FE0C | Break Address Register High (BRKH) | Read: | Bit 15 | Bit 14 | Bit 13 | Bit 12 | Bit 11 | Bit 10 | Bit 9 | Bit 8 |
| | | Write: | | | | | | | | |
| | | Reset: | 0 | 0 | 0 | 0 | 0 | 0 | 0 | 0 |
| \$FE0D | Break Address Register Low (BRKL) | Read: | Bit 7 | Bit 6 | Bit 5 | Bit 4 | Bit 3 | Bit 2 | Bit 1 | Bit 0 |
| | | Write: | | | | | | | | |
| | | Reset: | 0 | 0 | 0 | 0 | 0 | 0 | 0 | 0 |
| \$FE0E | Break Status/Control Register (BRKSCR) | Read: | BRKE | BRKA | 0 | 0 | 0 | 0 | 0 | 0 |
| | | Write: | | | | | | | | |
| | | Reset: | 0 | 0 | 0 | 0 | 0 | 0 | 0 | 0 |
| \$FE0F | | Unimplemented | | | | | | | | |

R = Reserved
 = Unimplemented

Figure 2-3. SIM Registers

| | |
|--------|-------------------------------------|
| \$FFD0 | Reserved |
| \$FFD1 | Reserved |
| \$FFD2 | External IRQ2/KBI Vector (High) |
| \$FFD3 | External IRQ2/KBI Vector (Low) |
| \$FFD4 | SCI Module Transmit Vector (High) |
| \$FFD5 | SCI Module Transmit Vector (Low) |
| \$FFD6 | SCI Module Receive Vector (High) |
| \$FFD7 | SCI Module Receive Vector (Low) |
| \$FFD8 | SCI Module Error Vector (High) |
| \$FFD9 | SCI Module Error Vector (Low) |
| \$FFDA | Reserved |
| \$FFDB | Reserved |
| \$FFDC | Reserved |
| \$FFDD | Reserved |
| \$FFDE | SPI 1 Module Transmit Vector (High) |
| \$FFDF | SPI 1 Module Transmit Vector (Low) |
| \$FFE0 | SPI 1 Module Receive Vector (High) |
| \$FFE1 | SPI 1 Module Receive Vector (Low) |
| \$FFE2 | Reserved |
| \$FFE3 | Reserved |
| \$FFE4 | Reserved |
| \$FFE5 | Reserved |
| \$FFE6 | FCM Module Vector (High) |
| \$FFE7 | FCM Module Vector (Low) |
| \$FFE8 | Reserved |
| \$FFE9 | Reserved |
| \$FFEA | TIM Overflow Vector (High) |
| \$FFEB | TIM Overflow Vector (Low) |
| \$FFEC | TIM Channel 3 Vector (High) |
| \$FFED | TIM Channel 3 Vector (Low) |
| \$FFEE | TIM Channel 2 Vector (High) |
| \$FFEF | TIM Channel 2 Vector (Low) |
| \$FFF0 | TIM Channel 1 Vector (High) |
| \$FFF1 | TIM Channel 1 Vector (Low) |
| \$FFF2 | TIM Channel 0 Vector (High) |

Figure 2-4. Vector Addresses in FLASH/ROM (Sheet 1 of 2)

| | |
|--------|----------------------------|
| \$FFF3 | TIM Channel 0 Vector (Low) |
| \$FFF4 | Reserved |
| \$FFF5 | Reserved |
| \$FFF6 | Reserved |
| \$FFF7 | Reserved |
| \$FFF8 | PLL Module Vector (High) |
| \$FFF9 | PLL Module Vector (Low) |
| \$FFFA | IRQ1 Vector (High) |
| \$FFFB | IRQ1 Vector (Low) |
| \$FFFC | SWI Vector (High) |
| \$FFFD | SWI Vector (Low) |
| \$FFFE | Reset Vector (High) |
| \$FFFF | Reset Vector (Low) |

Figure 2-4. Vector Addresses in FLASH/ROM (Sheet 2 of 2)

2.5 Monitor Read-Only Memory (ROM)

The 240 bytes at addresses \$FE10–\$FEFF are reserved ROM addresses that contain instructions for the monitor functions. For more information, see [Chapter 18 Monitor ROM \(MON\)](#).

Chapter 3

Random-Access Memory (RAM)

3.1 Introduction

This section describes the 3584 bytes of random-access memory (RAM).

3.2 Functional Description

Addresses \$0040–\$0E3F are RAM locations. The location of the stack RAM is programmable. The 16-bit stack pointer allows the stack to be anywhere in the 64-Kbyte memory space.

NOTE

For correct operation, the stack pointer must point only to RAM locations.

Within page zero are 192 bytes of RAM. Because the location of the stack RAM is programmable, all page zero RAM locations can be used for I/O (input/output) control and user data or code. When the stack pointer is moved from its reset location at \$00FF, direct addressing mode instructions can access all page zero RAM locations efficiently. Page zero RAM, therefore, provides ideal locations for frequently accessed global variables.

Before processing an interrupt, the CPU uses five bytes of the stack to save the contents of the CPU registers.

NOTE

For M6805 compatibility, the H register is not stacked.

During a subroutine call, the CPU uses two bytes of the stack to store the return address. The stack pointer decrements during pushes and increments during pulls.

NOTE

Be careful when using nested subroutines. The CPU may overwrite data in the RAM during a subroutine or during the interrupt stacking operation.

Chapter 4

FLASH Memory

4.1 Introduction

This section describes the operation of the embedded 60-Kbyte FLASH memory. The FLASH memory consists of two modules:

- FLASH1 — ~32 Kbytes, address range is \$8000–\$FDFF and \$FFD0–\$FFFF
- FLASH2 — 28 Kbytes, address range \$1000–\$7FFF

FLASH memory is non-volatile and can be read, programmed, and erased from a single external supply.

| Addr. | Register Name | Bit 7 | 6 | 5 | 4 | 3 | 2 | 1 | Bit 0 | |
|--------|--|--------|-------|-------|------|------|------|------|-------|------|
| \$0032 | FLASH2 Block Protect Register (FL2BPR) | Read: | | | | | | | | |
| | | Write: | | | | | BPR3 | BPR2 | BPR1 | BPR0 |
| | | Reset: | X | X | X | X | 1 | 1 | 1 | 1 |
| \$0033 | FLASH1 Block Protect Register (FL1BPR) | Read: | | | | | | | | |
| | | Write: | | | | | BPR3 | BPR2 | BPR1 | BPR0 |
| | | Reset: | X | X | X | X | 1 | 1 | 1 | 1 |
| \$FE09 | FLASH2 Control Register (FL2CR) | Read: | FDIV1 | FDIV0 | BLK1 | BLK0 | HVEN | MARG | ERASE | PGM |
| | | Write: | | | | | | | | |
| | | Reset: | 0 | 0 | 0 | 0 | 0 | 0 | 0 | 0 |
| \$FE0B | FLASH1 Control Register (FL1CR) | Read: | FDIV1 | FDIV0 | BLK1 | BLK0 | HVEN | MARG | ERASE | PGM |
| | | Write: | | | | | | | | |
| | | Reset: | 0 | 0 | 0 | 0 | 0 | 0 | 0 | 0 |

= Unimplemented X = Indeterminate

Figure 4-1. FLASH Register Summary

4.2 FLASH1 Functional Description

The FLASH1 memory array contains 32,304 bytes. An erased bit reads as a logic 0 and a programmed bit reads as a logic 1. Program and erase operations are facilitated through control bits in a memory mapped register. For additional details, see [4.10 FLASH Erase Operation](#) and [4.11 FLASH Program and Margin Read Operation](#).

Memory in the FLASH array is organized into pages and rows. There are eight pages of memory per row, and for this array, there are eight bytes per page. The minimum erase block size is a single row, 64 bytes. Programming is performed on a per-page basis, or for this array, eight bytes at a time. These are the address ranges for the 32-Kbyte FLASH memory:

- \$8000–\$FDFF, user FLASH array
- \$FFD0–\$FFFF, user vector space

FLASH Memory

When programming the FLASH, just enough program time must be utilized via an iterative programming algorithm. Too much program time can result in a disturb condition in which an erased bit becomes programmed. This can be prevented as long as no more than eight program operations are performed per row before again performing an erase operation. Each programmed page is read in margin mode to ensure that the bits are programmed enough for data retention over the device's lifetime. The row architecture for this array is:

| | |
|---------------|---------|
| \$8000–\$803F | Row 0 |
| \$8040–\$807F | Row 1 |
| \$8080–\$80BF | Row 2 |
| ↓ | ↓ |
| \$FFD0–\$FFFF | Row 504 |

4.3 FLASH2 Functional Description

The FLASH2 memory array contains 28,672 bytes. An erased bit reads as a logic 0 and a programmed bit reads as a logic 1. Program and erase operations are facilitated through control bits in a memory mapped register. Details for these operations appear later in this section.

Memory in the FLASH array is organized into pages and rows. There are eight pages of memory per row, and for this array, there are eight bytes per page. The minimum erase block size is a single row, 64 bytes. Programming is performed on a per page basis, or for this array, eight bytes at a time. Address range for the 28-Kbyte FLASH memory is \$1000–\$7FFF.

When programming the FLASH, just enough program time must be utilized via an iterative programming algorithm. Too much program time can result in a disturb condition in which an erased bit becomes programmed. This can be prevented as long as no more than eight program operations are performed per row before again performing an erase operation. Each programmed page is read in margin mode to ensure that the bits are programmed enough for data retention over the device's lifetime.

4.4 FLASH1 Control Register

The FLASH1 control register (FL1CR) controls FLASH program, erase, and margin operations.

| | | | | | | | | |
|----------|--------|-------|------|------|------|------|-------|-------|
| Address: | \$FE0B | | | | | | | |
| | Bit 7 | 6 | 5 | 4 | 3 | 2 | 1 | Bit 0 |
| Read: | FDIV1 | FDIV0 | BLK1 | BLK0 | HVEN | MARG | ERASE | PGM |
| Write: | | | | | | | | |
| Reset: | 0 | 0 | 0 | 0 | 0 | 0 | 0 | 0 |

Figure 4-2. FLASH1 Control Register (FL1CR)

CAUTION

Devices with more than one FLASH have multiple control registers (FLCRs.) Only one FLASH control register should be accessed at a time. So, while accessing one control register, ensure that any others are cleared.

FDIV0 — Frequency divide control bit

This bit selects the factor by which CGMVCLK is divided to derive the charge pump frequency. See [Table 4-3](#).

NOTE

FDIV1 has no effect.

BLK1 and BLK0 — Block erase control bits

These bits control erasing of blocks of varying size. [Table 4-1](#) shows the various block sizes which can be erased in one erase operation.

In step 4 of the erase operation (see [4.10 FLASH Erase Operation](#)), the upper addresses are latched and used to determine the location of the block to be erased. For the full array, the only requirement is that the target address points to any byte in this array. Writing to any address in the array will enable the erase.

HVEN — High voltage enable bit

This read/write bit enables high voltage from the charge pump to the memory for either program or erase operation. It can only be set if either PGM or ERASE is set.

- 1 = High voltage enabled to array and charge pump on
- 0 = High voltage disabled to array and charge pump off

Table 4-1. Erase Block Sizes of FLASH1

| BLK1 | BLK0 | Block size | Row boundaries |
|------|------|---------------------------|--|
| 0 | 0 | Full array: 32 Kbytes | 0-504 (\$8000–\$FFFF) |
| 0 | 1 | One-half array: 16 Kbytes | 0-255 (\$8000–\$BFFF) 256-504 (\$C000–\$FFFF) |
| 1 | 0 | Eight rows: 512 bytes | 0-7 (\$8000–\$81FF) 8-15 (\$8200–\$83FF) 16-23 (\$8400–\$85FF) ↓ 496-503 (\$FC00–\$FDFF) |
| 1 | 1 | Single row: 64 bytes | 0 (\$8000–\$803F) 1 (\$8040–\$807F) ↓ 504 (\$FFD0–\$FFFF) |

MARG — Program margin control bit

This read/write bit configures the memory for a program margin operation. It cannot be set if the HVEN bit is set, and if it is set when HVEN is set, it will automatically return to 0.

- 1 = Margin operation selected
- 0 = Margin operation unselected

ERASE — Erase control bit

This read/write bit configures the memory for erase operation. It is interlocked with the PGM bit such that both bits cannot be set to 1 at the same time.

- 1 = Erase operation selected
- 0 = Erase operation unselected

PGM — Program control bit

This read/write bit configures the memory for program operation. It is interlocked with the ERASE bit such that both bits cannot be equal to 1 or set to 1 at the same time.

- 1 = Program operation selected
- 0 = Program operation unselected

4.5 FLASH2 Control Register

The FLASH2 control register controls FLASH program, erase, and margin operations.

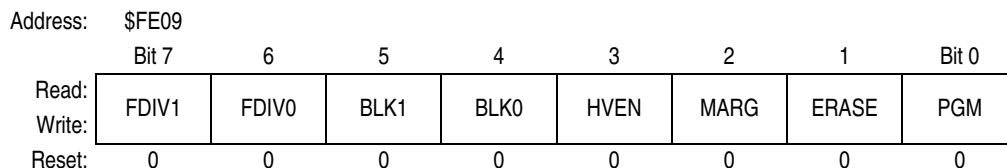

Figure 4-3. FLASH2 Control Register (FL2CR)

FDIV0 — Frequency divide control bit

This bit selects the factor by which CGMVCLK is divided to derive the charge pump frequency. See [Table 4-3](#).

NOTE

FDIV1 has no effect.

BLK1 and BLK0 — Block erase control bits

These bits control erasing of blocks of varying size. [Table 4-2](#) shows the various block sizes which can be erased in one erase operation.

Table 4-2. Erase Block Sizes of FLASH2

| BLK1 | BLK0 | Block size | Row boundaries |
|------|------|-----------------------|--|
| 0 | 0 | Full array: 28 Kbytes | \$1000–\$7FFF |
| 0 | 1 | One-half array | 12 Kbytes; \$1000–\$3FFF 16 Kbytes; \$4000–\$7FFF |
| 1 | 0 | Eight rows: 512 bytes | — |
| 1 | 1 | Single row: 64 bytes | — |

In step 4 of the erase operation (see [4.10 FLASH Erase Operation](#)), the upper addresses are latched and used to determine the location of the block to be erased. For the full array, the only requirement is that the target address points to any byte in this array. Writing to any address in the array will enable the erase.

HVEN — High-voltage enable bit

This read/write bit enables high voltage from the charge pump to the memory for either program or erase operation. It can only be set if either PGM or ERASE is set.

- 1 = High voltage enabled to array and charge pump on
- 0 = High voltage disabled to array and charge pump off

MARG — Program margin control bit

This read/write bit configures the memory for a program margin operation. It cannot be set if the HVEN bit is set, and if it is set when HVEN is set, it will automatically return to 0.

- 1 = Margin operation selected
- 0 = Margin operation unselected

ERASE — Erase control bit

This read/write bit configures the memory for erase operation. It is interlocked with the PGM bit such that both bits cannot be set to 1 at the same time.

- 1 = Erase operation selected
- 0 = Erase operation unselected

PGM — Program control bit

This read/write bit configures the memory for program operation. It is interlocked with the ERASE bit such that both bits cannot be equal to 1 or set to 1 at the same time.

- 1 = Program operation selected
- 0 = Program operation unselected

4.6 FLASH1 Block Protect Register

The block protect register is implemented as an input/output (I/O) register. Each bit, when programmed, protects a range of addresses in the FLASH.

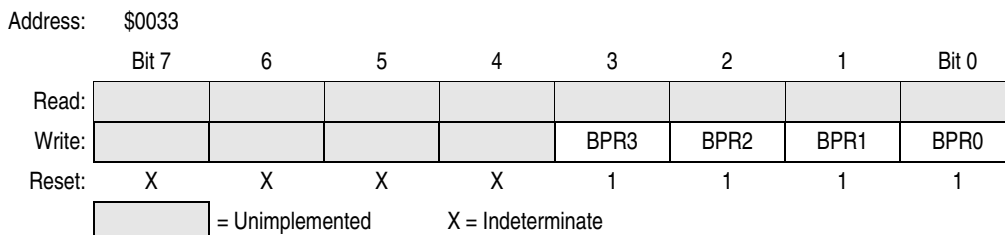

Figure 4-4. FLASH1 Block Protect Register (FL1BPR)

BPR3 — Block protect register bit 3

This bit protects the memory contents in the address range \$C000–\$FFFF.

- 1 = Address range protected from erase or program
- 0 = Address range open to erase or program

BPR2 — Block protect register bit 2

This bit protects the memory contents in the address range \$A000–\$FFFF.

- 1 = Address range protected from erase or program
- 0 = Address range open to erase or program

BPR1 — Block protect register bit 1

This bit protects the memory contents in the address range \$9000–\$FFFF.

- 1 = Address range protected from erase or program
- 0 = Address range open to erase or program

BPR0 — Block protect register bit 0

This bit protects the memory contents in the address range \$8000–\$FFFF.

- 1 = Address range protected from erase or program
- 0 = Address range open to erase or program

By programming the block protect bits, a portion of the memory will be locked so that no further erase or program operations may be performed. Programming more than one bit at a time is redundant. For instance, if both BPR3 and BPR2 are set, the address range \$A000–\$FFFF is locked. If all bits are cleared, then all of the memory is available for erase and program.

4.7 FLASH2 Block Protect Register

The block protect register is implemented as an I/O register. Each bit, when programmed, protects a range of addresses in the FLASH.

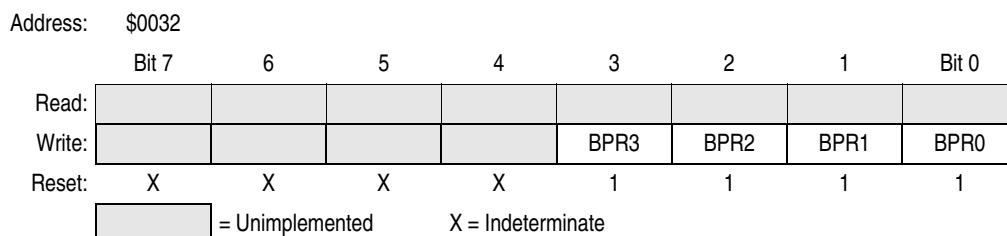

Figure 4-5. FLASH2 Block Protect Register (FL2BPR)

BPR3 — Block protect register bit 3

This bit protects the upper half portion of full-size 32-K array. Since FLASH2 is 28 Kbytes, the block protect address range is \$4000–\$7FFF.

1 = Address range protected from erase or program

0 = Address range open to erase or program

BPR2 — Block protect register bit 2

This bit protects the upper 3/4 portion of full-size 32-K array. Since FLASH2 is 28 Kbytes, the block protect address range is \$2000–\$7FFF.

1 = Address range protected from erase or program

0 = Address range open to erase or program

BPR1 — Block protect register bit 1

This bit protects the upper 7/8 portion of a full size 32-K array. Since FLASH2 is 28 Kbytes, the block protect address range is \$1000–\$7FFF.

1 = Address range protected from erase or program

0 = Address range open to erase or program

BPR0 — Block protect register bit 0

This bit protects all the memory contents in the address range \$1000–\$7FFF.

1 = Address range protected from erase or program

0 = Address range open to erase or program

By programming the block protect bits, a portion of the memory will be locked so that no further erase or program operations may be performed. Programming more than one bit at a time is redundant. If both BPR3 and BPR2 are set, for instance, the address range \$2000–\$7FFF is locked. If all bits are cleared, then all of the memory is available for erase and program.

4.8 Block Protection

Because of the ability of the on-board charge pump to erase and program the FLASH memory in the target application, provision is made for protecting blocks of memory from unintentional erase or program operations. This protection is done by reserving a location in the I/O space for block protect information. If the address range for an erase or program operation includes a protected block, the PGM or ERASE bit is cleared which prevents the HVEN bit in the FLASH control register from being set so that no high voltage is allowed in the array.

When the block protect register is cleared, the entire memory is accessible for program and erase. When bits within the register are programmed, they lock blocks of memory address ranges as shown in [4.6 FLASH1 Block Protect Register](#) and [4.7 FLASH2 Block Protect Register](#).

4.9 Charge Pump Frequency Control

The internal charge pump for this array is to be operated over the specified frequency range (refer to [Table 4-3](#)). The PLL output clock, CGMVCLK, is used to derive the two quadrature clocks, VCLK12 and VCLK23, which are one-half CGMVCLK. Additional pump frequency control is provided using the FDIV0 bit in order to keep the VCLKs within the specified range. The PLL must be ON and locked (but not necessarily engaged) before program/erase operations can be performed.

Table 4-3. Charge Pump Clock Frequency

| FDIV0 | Pump clock frequency |
|-------|----------------------|
| 0 | CGMVCLK ÷ 2 |
| 1 | CGMVCLK ÷ 4 |

4.10 FLASH Erase Operation

NOTE

After a total of eight program operations has been applied to a row, the row must be erased before further use in order to avoid a disturb condition. An erased byte will read \$00.

In [20.15 FLASH Memory Electrical Characteristics](#), a detailed description of the times used in this algorithm is given.

Use this procedure to erase a block of FLASH memory:

1. Establish pump frequency by configuring PLL.
2. Unprotect target portion of the array, BPR0–BPR3.
3. Set the ERASE bit, the BLK0, BLK1, and FDIV0 bits in the FLASH control register.
4. Write to any FLASH address with any data within the block address range desired.
5. Set the HVEN bit.
6. Wait for a time, t_{Erase} .
7. Clear the HVEN bit.
8. Wait for a time, t_{kill} , for the high voltages to dissipate.
9. Clear the ERASE bit.
10. After a time, t_{HVD} , the memory can be accessed in read mode again.

CAUTION

These operations must be performed in the order as shown, but other unrelated operations may occur between the steps. Do not exceed t_{ERASE} maximum.

4.11 FLASH Program and Margin Read Operation

Programming of this FLASH array is done on a page basis where one page equals eight bytes. The purpose of the margin read mode is to ensure that data has been programmed with sufficient margin for long term data retention. During a margin read, the control gates of the selected memory bits are held at a slightly negative voltage by an internal charge pump. Reading the data in margin mode is the same as for ordinary read mode except that a built-in counter stretches the data access for an additional eight cycles to allow sensing of the lower cell current. In short, a margin read applies a more stringent condition on the bitcell during read which ensures the data will be valid throughout the life of the product. A margin read can only follow a program operation. Refer to [Chapter 20 Preliminary Electrical Specifications](#).

The procedure for programming the FLASH memory is:

1. Establish pump frequency by configuring the PLL.
2. Set the PGM bit and program FDIV0 appropriately. This configures the memory for program operation and enables the latching of address and data for programming.
3. Write data to the page (eight bytes) being programmed.
4. Set the HVEN bit.
5. Wait for a time, t_{STEP} .
6. Clear the HVEN bit.
7. Wait for a time, t_{HVTV} .
8. Set the MARG bit.
9. Wait for a time, t_{VTP} .
10. Clear the PGM bit.
11. Wait for a time, t_{HVD} .
12. Read the page of data (this is in margin mode.)
13. Clear the MARG bit.
14. If any programmed bits do not read correctly, repeat the process from step 2 through step 13 up to maximum program pulses (see [Chapter 20 Preliminary Electrical Specifications](#)).

NOTE: THIS PAGE PROGRAM ALGORITHM ASSUMES THE PLL IS ON AND LOCKED AND THE PAGE TO BE PROGRAMMED HAS BEEN ERASED BEFORE ENTRY.

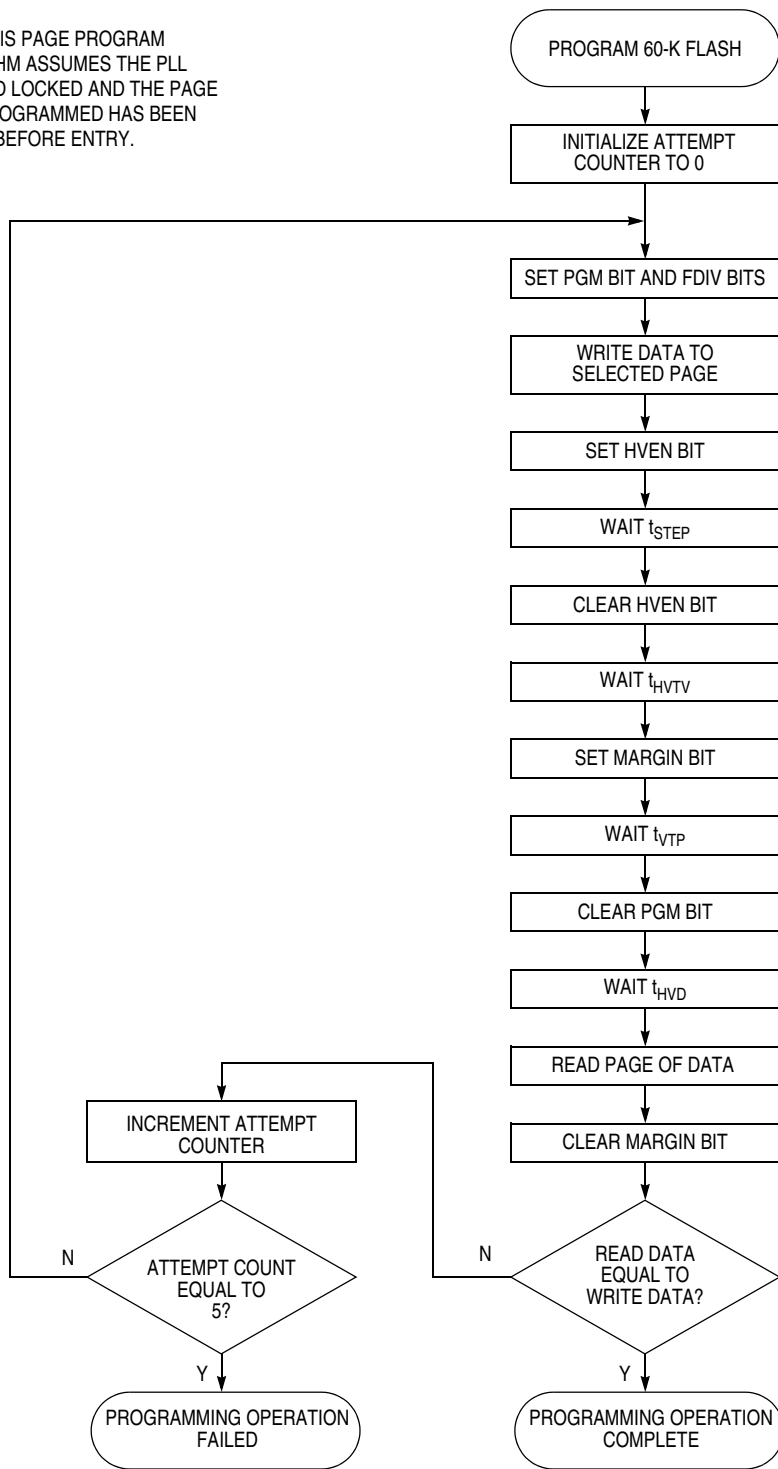

Figure 4-6. Page Program Algorithm

Chapter 5

Central Processor Unit (CPU)

5.1 Introduction

The M68HC08 CPU (central processor unit) is an enhanced and fully object-code-compatible version of the M68HC05 CPU. The *CPU08 Reference Manual* (document order number CPU08RM/AD) contains a description of the CPU instruction set, addressing modes, and architecture.

5.2 Features

Features of the CPU include:

- Object code fully upward-compatible with M68HC05 Family
- 16-bit stack pointer with stack manipulation instructions
- 16-bit index register with x-register manipulation instructions
- 8-MHz CPU internal bus frequency
- 64-Kbyte program/data memory space
- 16 addressing modes
- Memory-to-memory data moves without using accumulator
- Fast 8-bit by 8-bit multiply and 16-bit by 8-bit divide instructions
- Enhanced binary-coded decimal (BCD) data handling
- Modular architecture with expandable internal bus definition for extension of addressing range beyond 64 Kbytes
- Low-power stop and wait modes

5.3 CPU Registers

[Figure 5-1](#) shows the five CPU registers. CPU registers are not part of the memory map.

Central Processor Unit (CPU)

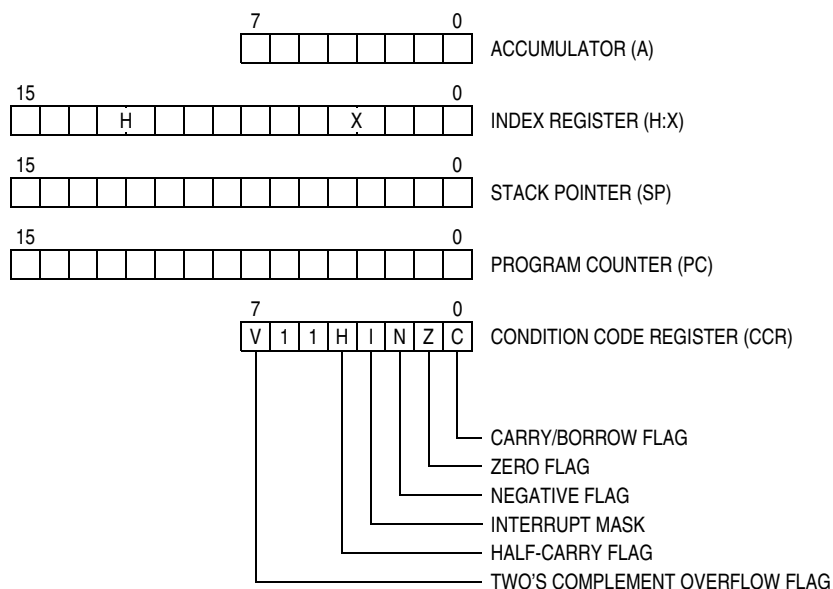

Figure 5-1. CPU Registers

5.3.1 Accumulator

The accumulator is a general-purpose 8-bit register. The CPU uses the accumulator to hold operands and the results of arithmetic/logic operations.

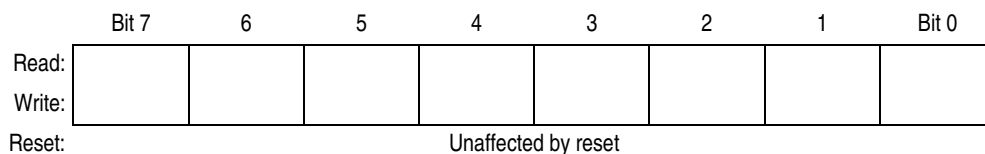

Figure 5-2. Accumulator (A)

5.3.2 Index Register

The 16-bit index register allows indexed addressing of a 64-Kbyte memory space. H is the upper byte of the index register, and X is the lower byte. H:X is the concatenated 16-bit index register.

In the indexed addressing modes, the CPU uses the contents of the index register to determine the conditional address of the operand.

The index register can serve also as a temporary data storage location.

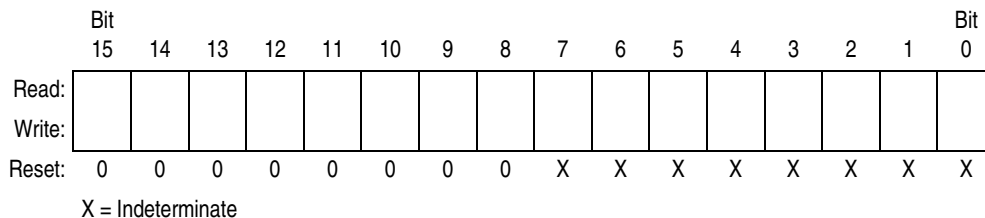

Figure 5-3. Index Register (H:X)

5.3.3 Stack Pointer

The stack pointer is a 16-bit register that contains the address of the next location on the stack. During a reset, the stack pointer is preset to \$00FF. The reset stack pointer (RSP) instruction sets the least significant byte to \$FF and does not affect the most significant byte. The stack pointer decrements as data is pushed onto the stack and increments as data is pulled from the stack.

In the stack pointer 8-bit offset and 16-bit offset addressing modes, the stack pointer can function as an index register to access data on the stack. The CPU uses the contents of the stack pointer to determine the conditional address of the operand.

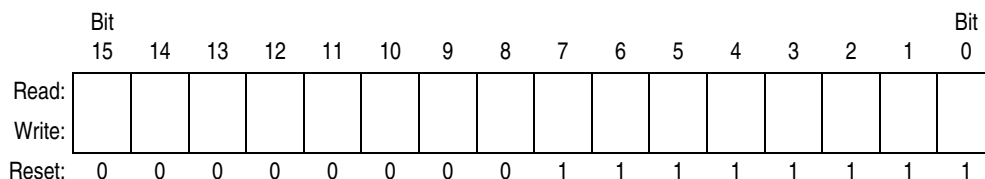

Figure 5-4. Stack Pointer (SP)

NOTE

The location of the stack is arbitrary and may be relocated anywhere in random-access memory (RAM). Moving the SP out of page 0 (\$0000 to \$00FF) frees direct address (page 0) space. For correct operation, the stack pointer must point only to RAM locations.

5.3.4 Program Counter

The program counter is a 16-bit register that contains the address of the next instruction or operand to be fetched.

Normally, the program counter automatically increments to the next sequential memory location every time an instruction or operand is fetched. Jump, branch, and interrupt operations load the program counter with an address other than that of the next sequential location.

During reset, the program counter is loaded with the reset vector address located at \$FFFE and \$FFFF. The vector address is the address of the first instruction to be executed after exiting the reset state.

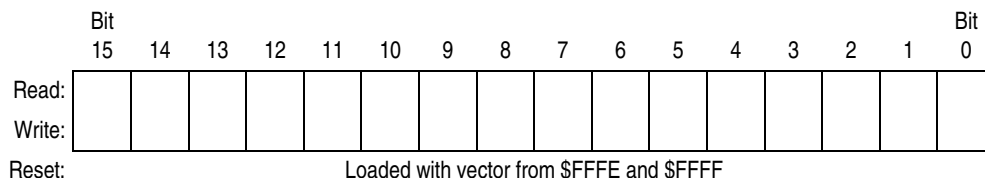

Figure 5-5. Program Counter (PC)

5.3.5 Condition Code Register

The 8-bit condition code register contains the interrupt mask and five flags that indicate the results of the instruction just executed. Bits 6 and 5 are set permanently to 1. The following paragraphs describe the functions of the condition code register.

| | Bit 7 | 6 | 5 | 4 | 3 | 2 | 1 | Bit 0 |
|--------|-------|---|---|---|---|---|---|-------|
| Read: | V | 1 | 1 | H | I | N | Z | C |
| Write: | | | | | | | | |
| Reset: | X | 1 | 1 | X | 1 | X | X | X |

X = Indeterminate

Figure 5-6. Condition Code Register (CCR)

V — Overflow Flag

The CPU sets the overflow flag when a two's complement overflow occurs. The signed branch instructions BGT, BGE, BLE, and BLT use the overflow flag.

- 1 = Overflow
- 0 = No overflow

H — Half-Carry Flag

The CPU sets the half-carry flag when a carry occurs between accumulator bits 3 and 4 during an add-without-carry (ADD) or add-with-carry (ADC) operation. The half-carry flag is required for binary-coded decimal (BCD) arithmetic operations. The DAA instruction uses the states of the H and C flags to determine the appropriate correction factor.

- 1 = Carry between bits 3 and 4
- 0 = No carry between bits 3 and 4

I — Interrupt Mask

When the interrupt mask is set, all maskable CPU interrupts are disabled. CPU interrupts are enabled when the interrupt mask is cleared. When a CPU interrupt occurs, the interrupt mask is set automatically after the CPU registers are saved on the stack, but before the interrupt vector is fetched.

- 1 = Interrupts disabled
- 0 = Interrupts enabled

NOTE

To maintain M6805 Family compatibility, the upper byte of the index register (H) is not stacked automatically. If the interrupt service routine modifies H, then the user must stack and unstack H using the PSHH and PULH instructions.

After the I bit is cleared, the highest-priority interrupt request is serviced first.

A return-from-interrupt (RTI) instruction pulls the CPU registers from the stack and restores the interrupt mask from the stack. After any reset, the interrupt mask is set and can be cleared only by the clear interrupt mask software instruction (CLI).

N — Negative Flag

The CPU sets the negative flag when an arithmetic operation, logic operation, or data manipulation produces a negative result, setting bit 7 of the result.

- 1 = Negative result
- 0 = Non-negative result

Z — Zero Flag

The CPU sets the zero flag when an arithmetic operation, logic operation, or data manipulation produces a result of \$00.

1 = Zero result

0 = Non-zero result

C — Carry/Borrow Flag

The CPU sets the carry/borrow flag when an addition operation produces a carry out of bit 7 of the accumulator or when a subtraction operation requires a borrow. Some instructions — such as bit test and branch, shift, and rotate — also clear or set the carry/borrow flag.

1 = Carry out of bit 7

0 = No carry out of bit 7

5.4 Arithmetic/Logic Unit (ALU)

The ALU performs the arithmetic and logic operations defined by the instruction set.

Refer to the *CPU08 Reference Manual* (document order number CPU08RM/AD) for a description of the instructions and addressing modes and more detail about the architecture of the CPU.

5.5 Low-Power Modes

The WAIT and STOP instructions put the MCU in low power-consumption standby modes.

5.5.1 Wait Mode

The WAIT instruction:

- Clears the interrupt mask (I bit) in the condition code register, enabling interrupts. After exit from wait mode by interrupt, the I bit remains clear. After exit by reset, the I bit is set.
- Disables the CPU clock

5.5.2 Stop Mode

The STOP instruction:

- Clears the interrupt mask (I bit) in the condition code register, enabling external interrupts. After exit from stop mode by external interrupt, the I bit remains clear. After exit by reset, the I bit is set.
- Disables the CPU clock

After exiting stop mode, the CPU clock begins running after the oscillator stabilization delay.

5.6 CPU During Break Interrupts

If a break module is present on the MCU, the CPU starts a break interrupt by:

- Loading the instruction register with the SWI instruction
- Loading the program counter with \$FFFC:\$FFFD or with \$FEFC:\$FEFD in monitor mode

The break interrupt begins after completion of the CPU instruction in progress. If the break address register match occurs on the last cycle of a CPU instruction, the break interrupt begins immediately.

A return-from-interrupt instruction (RTI) in the break routine ends the break interrupt and returns the MCU to normal operation if the break interrupt has been deasserted.

5.7 Instruction Set Summary

Table 5-1 provides a summary of the M68HC08 instruction set.

Table 5-1. Instruction Set Summary (Sheet 1 of 6)

| Source Form | Operation | Description | Effect on CCR | | | | | Address Mode | Opcode | Operand | Cycles | |
|--|---|---|---------------|---|---|---|---|--------------|--|--|---|--------------------------------------|
| | | | V | H | I | N | Z | | | | | C |
| ADC #opr ADC opr ADC opr ADC opr,X ADC opr,X ADC ,X ADC opr,SP ADC opr,SP | Add with Carry | $A \leftarrow (A) + (M) + (C)$ | † | † | - | † | † | † | IMM DIR EXT IX2 IX1 IX SP1 SP2 | A9 B9 C9 D9 E9 F9 9EE9 9ED9 | ii dd hh ll ee ff ff ff ff ee ff | 2 3 4 4 3 2 4 5 |
| ADD #opr ADD opr ADD opr ADD opr,X ADD opr,X ADD ,X ADD opr,SP ADD opr,SP | Add without Carry | $A \leftarrow (A) + (M)$ | † | † | - | † | † | † | IMM DIR EXT IX2 IX1 IX SP1 SP2 | AB BB CB DB EB FB 9EEB 9EDB | ii dd hh ll ee ff ff ff ff ee ff | 2 3 4 4 3 2 4 5 |
| AIS #opr | Add Immediate Value (Signed) to SP | $SP \leftarrow (SP) + (16 \ll M)$ | - | - | - | - | - | - | IMM | A7 | ii | 2 |
| AIX #opr | Add Immediate Value (Signed) to H:X | $H:X \leftarrow (H:X) + (16 \ll M)$ | - | - | - | - | - | - | IMM | AF | ii | 2 |
| AND #opr AND opr AND opr AND opr,X AND opr,X AND ,X AND opr,SP AND opr,SP | Logical AND | $A \leftarrow (A) \& (M)$ | 0 | - | - | † | † | - | IMM DIR EXT IX2 IX1 IX SP1 SP2 | A4 B4 C4 D4 E4 F4 9EE4 9ED4 | ii dd hh ll ee ff ff ff ff ee ff | 2 3 4 4 3 2 4 5 |
| ASL opr ASLA ASLX ASL opr,X ASL ,X ASL opr,SP | Arithmetic Shift Left (Same as LSL) |  | † | - | - | † | † | † | DIR INH INH IX1 IX SP1 | 38 48 58 68 78 9E68 | dd ff ff ff | 4 1 1 4 3 5 |
| ASR opr ASRA ASRX ASR opr,X ASR opr,X ASR opr,SP | Arithmetic Shift Right |  | † | - | - | † | † | † | DIR INH INH IX1 IX SP1 | 37 47 57 67 77 9E67 | dd ff ff ff | 4 1 1 4 3 5 |
| BCC rel | Branch if Carry Bit Clear | $PC \leftarrow (PC) + 2 + rel ? (C) = 0$ | - | - | - | - | - | - | REL | 24 | rr | 3 |
| BCLR n, opr | Clear Bit n in M | $M_n \leftarrow 0$ | - | - | - | - | - | - | DIR (b0) DIR (b1) DIR (b2) DIR (b3) DIR (b4) DIR (b5) DIR (b6) DIR (b7) | 11 13 15 17 19 1B 1D 1F | dd dd dd dd dd dd dd dd | 4 4 4 4 4 4 4 4 |
| BCS rel | Branch if Carry Bit Set (Same as BLO) | $PC \leftarrow (PC) + 2 + rel ? (C) = 1$ | - | - | - | - | - | - | REL | 25 | rr | 3 |
| BEQ rel | Branch if Equal | $PC \leftarrow (PC) + 2 + rel ? (Z) = 1$ | - | - | - | - | - | - | REL | 27 | rr | 3 |
| BGE opr | Branch if Greater Than or Equal To (Signed Operands) | $PC \leftarrow (PC) + 2 + rel ? (N \oplus V) = 0$ | - | - | - | - | - | - | REL | 90 | rr | 3 |
| BGT opr | Branch if Greater Than (Signed Operands) | $PC \leftarrow (PC) + 2 + rel ? (Z) \mid (N \oplus V) = 0$ | - | - | - | - | - | - | REL | 92 | rr | 3 |

Table 5-1. Instruction Set Summary (Sheet 2 of 6)

| Source Form | Operation | Description | Effect on CCR | | | | | Address Mode | Opcode | Operand | Cycles | |
|--|---|--|---------------|---|---|---|---|--------------|--|--|--|--------------------------------------|
| | | | V | H | I | N | Z | | | | | C |
| BHCC <i>rel</i> | Branch if Half Carry Bit Clear | $PC \leftarrow (PC) + 2 + rel ? (H) = 0$ | - | - | - | - | - | REL | 28 | rr | 3 | |
| BHCS <i>rel</i> | Branch if Half Carry Bit Set | $PC \leftarrow (PC) + 2 + rel ? (H) = 1$ | - | - | - | - | - | REL | 29 | rr | 3 | |
| BHI <i>rel</i> | Branch if Higher | $PC \leftarrow (PC) + 2 + rel ? (C) \vee (Z) = 0$ | - | - | - | - | - | REL | 22 | rr | 3 | |
| BHS <i>rel</i> | Branch if Higher or Same (Same as BCC) | $PC \leftarrow (PC) + 2 + rel ? (C) = 0$ | - | - | - | - | - | REL | 24 | rr | 3 | |
| BIH <i>rel</i> | Branch if \overline{IRQ} Pin High | $PC \leftarrow (PC) + 2 + rel ? \overline{IRQ} = 1$ | - | - | - | - | - | REL | 2F | rr | 3 | |
| BIL <i>rel</i> | Branch if \overline{IRQ} Pin Low | $PC \leftarrow (PC) + 2 + rel ? \overline{IRQ} = 0$ | - | - | - | - | - | REL | 2E | rr | 3 | |
| BIT # <i>opr</i> BIT <i>opr</i> BIT <i>opr</i> BIT <i>opr,X</i> BIT <i>opr,X</i> BIT <i>X</i> BIT <i>opr,SP</i> BIT <i>opr,SP</i> | Bit Test | (A) & (M) | 0 | - | - | † | † | - | IMM DIR EXT IX2 IX1 IX SP1 SP2 | A5 B5 C5 D5 E5 F5 9EE5 9ED5 | ii dd hh ll ee ff ff ff ff ee ff | 2 3 4 4 3 2 4 5 |
| BLE <i>opr</i> | Branch if Less Than or Equal To (Signed Operands) | $PC \leftarrow (PC) + 2 + rel ? (Z) \vee (N \oplus V) = 1$ | - | - | - | - | - | REL | 93 | rr | 3 | |
| BLO <i>rel</i> | Branch if Lower (Same as BCS) | $PC \leftarrow (PC) + 2 + rel ? (C) = 1$ | - | - | - | - | - | REL | 25 | rr | 3 | |
| BLS <i>rel</i> | Branch if Lower or Same | $PC \leftarrow (PC) + 2 + rel ? (C) \vee (Z) = 1$ | - | - | - | - | - | REL | 23 | rr | 3 | |
| BLT <i>opr</i> | Branch if Less Than (Signed Operands) | $PC \leftarrow (PC) + 2 + rel ? (N \oplus V) = 1$ | - | - | - | - | - | REL | 91 | rr | 3 | |
| BMC <i>rel</i> | Branch if Interrupt Mask Clear | $PC \leftarrow (PC) + 2 + rel ? (I) = 0$ | - | - | - | - | - | REL | 2C | rr | 3 | |
| BMI <i>rel</i> | Branch if Minus | $PC \leftarrow (PC) + 2 + rel ? (N) = 1$ | - | - | - | - | - | REL | 2B | rr | 3 | |
| BMS <i>rel</i> | Branch if Interrupt Mask Set | $PC \leftarrow (PC) + 2 + rel ? (I) = 1$ | - | - | - | - | - | REL | 2D | rr | 3 | |
| BNE <i>rel</i> | Branch if Not Equal | $PC \leftarrow (PC) + 2 + rel ? (Z) = 0$ | - | - | - | - | - | REL | 26 | rr | 3 | |
| BPL <i>rel</i> | Branch if Plus | $PC \leftarrow (PC) + 2 + rel ? (N) = 0$ | - | - | - | - | - | REL | 2A | rr | 3 | |
| BRA <i>rel</i> | Branch Always | $PC \leftarrow (PC) + 2 + rel$ | - | - | - | - | - | REL | 20 | rr | 3 | |
| BRCLR <i>n,opr,rel</i> | Branch if Bit <i>n</i> in M Clear | $PC \leftarrow (PC) + 3 + rel ? (Mn) = 0$ | - | - | - | - | † | - | DIR (b0) DIR (b1) DIR (b2) DIR (b3) DIR (b4) DIR (b5) DIR (b6) DIR (b7) | 01 03 05 07 09 0B 0D 0F | dd rr dd rr dd rr dd rr dd rr dd rr dd rr dd rr | 5 5 5 5 5 5 5 5 |
| BRN <i>rel</i> | Branch Never | $PC \leftarrow (PC) + 2$ | - | - | - | - | - | REL | 21 | rr | 3 | |
| BRSET <i>n,opr,rel</i> | Branch if Bit <i>n</i> in M Set | $PC \leftarrow (PC) + 3 + rel ? (Mn) = 1$ | - | - | - | - | † | - | DIR (b0) DIR (b1) DIR (b2) DIR (b3) DIR (b4) DIR (b5) DIR (b6) DIR (b7) | 00 02 04 06 08 0A 0C 0E | dd rr dd rr dd rr dd rr dd rr dd rr dd rr dd rr | 5 5 5 5 5 5 5 5 |
| BSET <i>n,opr</i> | Set Bit <i>n</i> in M | $Mn \leftarrow 1$ | - | - | - | - | - | - | DIR (b0) DIR (b1) DIR (b2) DIR (b3) DIR (b4) DIR (b5) DIR (b6) DIR (b7) | 10 12 14 16 18 1A 1C 1E | dd dd dd dd dd dd dd dd | 4 4 4 4 4 4 4 4 |
| BSR <i>rel</i> | Branch to Subroutine | $PC \leftarrow (PC) + 2$; push (PCL) $SP \leftarrow (SP) - 1$; push (PCH) $SP \leftarrow (SP) - 1$ $PC \leftarrow (PC) + rel$ | - | - | - | - | - | REL | AD | rr | 4 | |

Table 5-1. Instruction Set Summary (Sheet 3 of 6)

| Source Form | Operation | Description | Effect on CCR | | | | | Address Mode | Opcode | Operand | Cycles | |
|---|----------------------------------|---|---------------|---|---|---|---|--------------|---|--|--|--------------------------------------|
| | | | V | H | I | N | Z | | | | | C |
| CBEQ <i>opr,rel</i> CBEQA # <i>opr,rel</i> CBEQX # <i>opr,rel</i> CBEQ <i>opr,X+,rel</i> CBEQ <i>X+,rel</i> CBEQ <i>opr,SP,rel</i> | Compare and Branch if Equal | PC ← (PC) + 3 + rel ? (A) – (M) = \$00 PC ← (PC) + 3 + rel ? (A) – (M) = \$00 PC ← (PC) + 3 + rel ? (X) – (M) = \$00 PC ← (PC) + 3 + rel ? (A) – (M) = \$00 PC ← (PC) + 2 + rel ? (A) – (M) = \$00 PC ← (PC) + 4 + rel ? (A) – (M) = \$00 | – | – | – | – | – | – | DIR IMM IMM IX1+ IX+ SP1 | 31 41 51 61 71 9E61 | dd rr ii rr ii rr ff rr rr ff rr | 5 4 4 5 4 6 |
| CLC | Clear Carry Bit | C ← 0 | – | – | – | – | 0 | INH | 98 | | 1 | |
| CLI | Clear Interrupt Mask | I ← 0 | – | – | 0 | – | – | INH | 9A | | 2 | |
| CLR <i>opr</i> CLRA CLR X CLR H CLR <i>opr,X</i> CLR ,X CLR <i>opr,SP</i> | Clear | M ← \$00 A ← \$00 X ← \$00 H ← \$00 M ← \$00 M ← \$00 M ← \$00 | 0 | – | – | 0 | 1 | – | DIR INH INH INH IX1 IX SP1 | 3F 4F 5F 8C 6F 7F 9E6F | dd ff ff | 3 1 1 1 3 2 4 |
| CMP # <i>opr</i> CMP <i>opr</i> CMP <i>opr</i> CMP <i>opr,X</i> CMP <i>opr,X</i> CMP ,X CMP <i>opr,SP</i> CMP <i>opr,SP</i> | Compare A with M | (A) – (M) | † | – | – | † | † | † | IMM DIR EXT IX2 IX1 IX SP1 SP2 | A1 B1 C1 D1 E1 F1 9EE1 9ED1 | ii dd hh ll ee ff ee ff ff ff ee ff | 2 3 4 4 3 2 4 5 |
| COM <i>opr</i> COMA COM X COM <i>opr,X</i> COM ,X COM <i>opr,SP</i> | Complement (One's Complement) | M ← (M) = \$FF – (M) A ← (A) = \$FF – (M) X ← (X) = \$FF – (M) M ← (M) = \$FF – (M) M ← (M) = \$FF – (M) M ← (M) = \$FF – (M) | 0 | – | – | † | † | 1 | DIR INH INH IX1 IX SP1 | 33 43 53 63 73 9E63 | dd ff ff | 4 1 1 4 3 5 |
| CPHX # <i>opr</i> CPHX <i>opr</i> | Compare H:X with M | (H:X) – (M:M + 1) | † | – | – | † | † | † | IMM DIR | 65 75 | ii ii+1 dd | 3 4 |
| CPX # <i>opr</i> CPX <i>opr</i> CPX <i>opr</i> CPX ,X CPX <i>opr,X</i> CPX <i>opr,X</i> CPX <i>opr,SP</i> CPX <i>opr,SP</i> | Compare X with M | (X) – (M) | † | – | – | † | † | † | IMM DIR EXT IX2 IX1 IX SP1 SP2 | A3 B3 C3 D3 E3 F3 9EE3 9ED3 | ii dd hh ll ee ff ff ff ff ee ff | 2 3 4 4 3 2 4 5 |
| DAA | Decimal Adjust A | (A) ₁₀ | U | – | – | † | † | † | INH | 72 | | 2 |
| DBNZ <i>opr,rel</i> DBNZA <i>rel</i> DBNZX <i>rel</i> DBNZ <i>opr,X,rel</i> DBNZ <i>X,rel</i> DBNZ <i>opr,SP,rel</i> | Decrement and Branch if Not Zero | A ← (A) – 1 or M ← (M) – 1 or X ← (X) – 1 PC ← (PC) + 3 + rel ? (result) ≠ 0 PC ← (PC) + 2 + rel ? (result) ≠ 0 PC ← (PC) + 2 + rel ? (result) ≠ 0 PC ← (PC) + 3 + rel ? (result) ≠ 0 PC ← (PC) + 2 + rel ? (result) ≠ 0 PC ← (PC) + 4 + rel ? (result) ≠ 0 | – | – | – | – | – | – | DIR INH INH IX1 IX SP1 | 3B 4B 5B 6B 7B 9E6B | dd rr rr rr ff rr rr ff rr | 5 3 3 4 4 6 |
| DEC <i>opr</i> DECA DEC X DEC <i>opr,X</i> DEC ,X DEC <i>opr,SP</i> | Decrement | M ← (M) – 1 A ← (A) – 1 X ← (X) – 1 M ← (M) – 1 M ← (M) – 1 M ← (M) – 1 | † | – | – | † | † | – | DIR INH INH IX1 IX SP1 | 3A 4A 5A 6A 7A 9E6A | dd ff ff | 4 1 1 4 3 5 |
| DIV | Divide | A ← (H:A)/(X) H ← Remainder | – | – | – | – | † | † | INH | 52 | | 7 |
| EOR # <i>opr</i> EOR <i>opr</i> EOR <i>opr</i> EOR <i>opr,X</i> EOR <i>opr,X</i> EOR ,X EOR <i>opr,SP</i> EOR <i>opr,SP</i> | Exclusive OR M with A | A ← (A ⊕ M) | 0 | – | – | † | † | – | IMM DIR EXT IX2 IX1 IX SP1 SP2 | A8 B8 C8 D8 E8 F8 9EE8 9ED8 | ii dd hh ll ee ff ff ff ff ee ff | 2 3 4 4 3 2 4 5 |

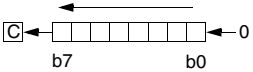
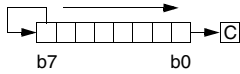
Table 5-1. Instruction Set Summary (Sheet 4 of 6)

| Source Form | Operation | Description | Effect on CCR | | | | | Address Mode | Opcode | Operand | Cycles | |
|--|-------------------------------------|--|---------------|---|---|---|---|--------------|---|--|---|--------------------------------------|
| | | | V | H | I | N | Z | | | | | C |
| INC <i>opr</i> INCA INCX INC <i>opr</i> ,X INC ,X INC <i>opr</i> ,SP | Increment | $M \leftarrow (M) + 1$ $A \leftarrow (A) + 1$ $X \leftarrow (X) + 1$ $M \leftarrow (M) + 1$ $M \leftarrow (M) + 1$ $M \leftarrow (M) + 1$ | † | - | - | † | † | - | DIR INH INH IX1 IX SP1 | 3C 4C 5C 6C 7C 9E6C | dd hh ll ff ff ff | 4 1 1 4 3 5 |
| JMP <i>opr</i> JMP <i>opr</i> JMP <i>opr</i> ,X JMP <i>opr</i> ,X JMP ,X | Jump | PC ← Jump Address | - | - | - | - | - | - | DIR EXT IX2 IX1 IX | BC CC DC EC FC | dd hh ll ee ff ff | 2 3 4 3 2 |
| JSR <i>opr</i> JSR <i>opr</i> JSR <i>opr</i> ,X JSR <i>opr</i> ,X JSR ,X | Jump to Subroutine | $PC \leftarrow (PC) + n$ ($n = 1, 2, \text{ or } 3$) Push (PCL); $SP \leftarrow (SP) - 1$ Push (PCH); $SP \leftarrow (SP) - 1$ PC ← Unconditional Address | - | - | - | - | - | - | DIR EXT IX2 IX1 IX | BD CD DD ED FD | dd hh ll ee ff ff | 4 5 6 5 4 |
| LDA # <i>opr</i> LDA <i>opr</i> LDA <i>opr</i> LDA <i>opr</i> ,X LDA <i>opr</i> ,X LDA ,X LDA <i>opr</i> ,SP LDA <i>opr</i> ,SP | Load A from M | $A \leftarrow (M)$ | 0 | - | - | † | † | - | IMM DIR EXT IX2 IX1 IX SP1 SP2 | A6 B6 C6 D6 E6 F6 9EE6 9ED6 | ii dd hh ll ee ff ff ff ee ff | 2 3 4 4 3 2 4 5 |
| LDHX # <i>opr</i> LDHX <i>opr</i> | Load H:X from M | $H:X \leftarrow (M:M + 1)$ | 0 | - | - | † | † | - | IMM DIR | 45 55 | ii jj dd | 3 4 |
| LDX # <i>opr</i> LDX <i>opr</i> LDX <i>opr</i> LDX <i>opr</i> ,X LDX <i>opr</i> ,X LDX ,X LDX <i>opr</i> ,SP LDX <i>opr</i> ,SP | Load X from M | $X \leftarrow (M)$ | 0 | - | - | † | † | - | IMM DIR EXT IX2 IX1 IX SP1 SP2 | AE BE CE DE EE FE 9EEE 9EDE | ii dd hh ll ee ff ff ff ee ff | 2 3 4 4 3 2 4 5 |
| LSL <i>opr</i> LSLA LSLX LSL <i>opr</i> ,X LSL ,X LSL <i>opr</i> ,SP | Logical Shift Left (Same as ASL) | | † | - | - | † | † | † | DIR INH INH IX1 IX SP1 | 38 48 58 68 78 9E68 | dd ff ff | 4 1 1 4 3 5 |
| LSR <i>opr</i> LSRA LSRX LSR <i>opr</i> ,X LSR ,X LSR <i>opr</i> ,SP | Logical Shift Right | | † | - | - | 0 | † | † | DIR INH INH IX1 IX SP1 | 34 44 54 64 74 9E64 | dd ff ff | 4 1 1 4 3 5 |
| MOV <i>opr</i> , <i>opr</i> MOV <i>opr</i> ,X+ MOV # <i>opr</i> , <i>opr</i> MOV X+, <i>opr</i> | Move | $(M)_{\text{Destination}} \leftarrow (M)_{\text{Source}}$ $H:X \leftarrow (H:X) + 1$ (IX+, DIX+) | 0 | - | - | † | † | - | DD DIX+ IMD IX+D | 4E 5E 6E 7E | dd dd dd ii dd dd | 5 4 4 4 |
| MUL | Unsigned multiply | $X:A \leftarrow (X) \times (A)$ | - | 0 | - | - | - | 0 | INH | 42 | | 5 |
| NEG <i>opr</i> NEGA NEGX NEG <i>opr</i> ,X NEG ,X NEG <i>opr</i> ,SP | Negate (Two's Complement) | $M \leftarrow -(M) = \$00 - (M)$ $A \leftarrow -(A) = \$00 - (A)$ $X \leftarrow -(X) = \$00 - (X)$ $M \leftarrow -(M) = \$00 - (M)$ $M \leftarrow -(M) = \$00 - (M)$ | † | - | - | † | † | † | DIR INH INH IX1 IX SP1 | 30 40 50 60 70 9E60 | dd ff ff | 4 1 1 4 3 5 |
| NOP | No Operation | None | - | - | - | - | - | - | INH | 9D | | 1 |
| NSA | Nibble Swap A | $A \leftarrow (A[3:0]:A[7:4])$ | - | - | - | - | - | - | INH | 62 | | 3 |

Table 5-1. Instruction Set Summary (Sheet 5 of 6)

| Source Form | Operation | Description | Effect on CCR | | | | | Address Mode | Opcode | Operand | Cycles | |
|--|--|---|---------------|---|---|---|---|--------------|--|--|---|--------------------------------------|
| | | | V | H | I | N | Z | | | | | C |
| ORA #opr ORA opr ORA opr ORA opr,X ORA opr,X ORA ,X ORA opr,SP ORA opr,SP | Inclusive OR A and M | $A \leftarrow (A) (M)$ | 0 | - | - | † | † | - | IMM DIR EXT IX2 DA EA FA IX SP1 SP2 | AA BA CA DA EA FA 9EEA 9EDA | ii dd hh ll ee ff ff ff ee ff | 2 3 4 4 3 2 4 5 |
| PSHA | Push A onto Stack | Push (A); $SP \leftarrow (SP) - 1$ | - | - | - | - | - | - | INH | 87 | | 2 |
| PSHH | Push H onto Stack | Push (H); $SP \leftarrow (SP) - 1$ | - | - | - | - | - | - | INH | 8B | | 2 |
| PSHX | Push X onto Stack | Push (X); $SP \leftarrow (SP) - 1$ | - | - | - | - | - | - | INH | 89 | | 2 |
| PULA | Pull A from Stack | $SP \leftarrow (SP) + 1$; Pull (A) | - | - | - | - | - | - | INH | 86 | | 2 |
| PULH | Pull H from Stack | $SP \leftarrow (SP) + 1$; Pull (H) | - | - | - | - | - | - | INH | 8A | | 2 |
| PULX | Pull X from Stack | $SP \leftarrow (SP) + 1$; Pull (X) | - | - | - | - | - | - | INH | 88 | | 2 |
| ROL opr ROLA ROLX ROL opr,X ROL ,X ROL opr,SP | Rotate Left through Carry |  | † | - | - | † | † | † | DIR INH INH IX1 IX SP1 | 39 49 59 69 79 9E69 | dd ff ff | 4 1 1 4 3 5 |
| ROR opr RORA RORX ROR opr,X ROR ,X ROR opr,SP | Rotate Right through Carry |  | † | - | - | † | † | † | DIR INH INH IX1 IX SP1 | 36 46 56 66 76 9E66 | dd ff ff | 4 1 1 4 3 5 |
| RSP | Reset Stack Pointer | $SP \leftarrow \$FF$ | - | - | - | - | - | - | INH | 9C | | 1 |
| RTI | Return from Interrupt | $SP \leftarrow (SP) + 1$; Pull (CCR) $SP \leftarrow (SP) + 1$; Pull (A) $SP \leftarrow (SP) + 1$; Pull (X) $SP \leftarrow (SP) + 1$; Pull (PCH) $SP \leftarrow (SP) + 1$; Pull (PCL) | † | † | † | † | † | † | INH | 80 | | 7 |
| RTS | Return from Subroutine | $SP \leftarrow SP + 1$; Pull (PCH) $SP \leftarrow SP + 1$; Pull (PCL) | - | - | - | - | - | - | INH | 81 | | 4 |
| SBC #opr SBC opr SBC opr SBC opr,X SBC opr,X SBC ,X SBC opr,SP SBC opr,SP | Subtract with Carry | $A \leftarrow (A) - (M) - (C)$ | † | - | - | † | † | † | IMM DIR EXT IX2 D2 E2 F2 IX SP1 SP2 | A2 B2 C2 D2 E2 F2 9EE2 9ED2 | ii dd hh ll ee ff ff ff ff ee ff | 2 3 4 4 3 2 4 5 |
| SEC | Set Carry Bit | $C \leftarrow 1$ | - | - | - | - | - | 1 | INH | 99 | | 1 |
| SEI | Set Interrupt Mask | $I \leftarrow 1$ | - | - | 1 | - | - | - | INH | 9B | | 2 |
| STA opr STA opr STA opr,X STA opr,X STA ,X STA opr,SP STA opr,SP | Store A in M | $M \leftarrow (A)$ | 0 | - | - | † | † | - | DIR EXT IX2 IX1 IX SP1 SP2 | B7 C7 D7 E7 F7 9EE7 9ED7 | dd hh ll ee ff ff ff ff ee ff | 3 4 4 3 2 4 5 |
| STHX opr | Store H:X in M | $(M:M + 1) \leftarrow (H:X)$ | 0 | - | - | † | † | - | DIR | 35 | dd | 4 |
| STOP | Enable Interrupts, Stop Processing, Refer to MCU Documentation | $I \leftarrow 0$; Stop Processing | - | - | 0 | - | - | - | INH | 8E | | 1 |
| STX opr STX opr STX opr,X STX opr,X STX ,X STX opr,SP STX opr,SP | Store X in M | $M \leftarrow (X)$ | 0 | - | - | † | † | - | DIR EXT IX2 IX1 IX SP1 SP2 | BF CF DF EF FF 9EEF 9EDF | dd hh ll ee ff ff ff ff ee ff | 3 4 4 3 2 4 5 |

Table 5-1. Instruction Set Summary (Sheet 6 of 6)

| Source Form | Operation | Description | Effect on CCR | | | | | Address Mode | Opcode | Operand | Cycles | |
|--|---------------------------------------|--|---------------|---|---|---|---|--------------|---|--|---|--------------------------------------|
| | | | V | H | I | N | Z | | | | | C |
| SUB #opr SUB opr SUB opr SUB opr,X SUB opr,X SUB ,X SUB opr,SP SUB opr,SP | Subtract | $A \leftarrow (A) - (M)$ | † | - | - | † | † | † | IMM DIR EXT IX2 IX1 IX SP1 SP2 | A0 B0 C0 D0 E0 F0 9EE0 9ED0 | ii dd hh ll ee ff ff ff ff ff | 2 3 4 4 3 2 4 5 |
| SWI | Software Interrupt | PC ← (PC) + 1; Push (PCL) SP ← (SP) - 1; Push (PCH) SP ← (SP) - 1; Push (X) SP ← (SP) - 1; Push (A) SP ← (SP) - 1; Push (CCR) SP ← (SP) - 1; I ← 1 PCH ← Interrupt Vector High Byte PCL ← Interrupt Vector Low Byte | - | - | 1 | - | - | - | INH | 83 | | 9 |
| TAP | Transfer A to CCR | $CCR \leftarrow (A)$ | † | † | † | † | † | † | INH | 84 | | 2 |
| TAX | Transfer A to X | $X \leftarrow (A)$ | - | - | - | - | - | - | INH | 97 | | 1 |
| TPA | Transfer CCR to A | $A \leftarrow (CCR)$ | - | - | - | - | - | - | INH | 85 | | 1 |
| TST opr TSTA TSTX TST opr,X TST ,X TST opr,SP | Test for Negative or Zero | $(A) - \$00$ or $(X) - \$00$ or $(M) - \$00$ | 0 | - | - | † | † | - | DIR INH INH IX1 IX SP1 | 3D 4D 5D 6D 7D 9E6D | dd ff ff | 3 1 1 3 2 4 |
| TSX | Transfer SP to H:X | $H:X \leftarrow (SP) + 1$ | - | - | - | - | - | - | INH | 95 | | 2 |
| TXA | Transfer X to A | $A \leftarrow (X)$ | - | - | - | - | - | - | INH | 9F | | 1 |
| TXS | Transfer H:X to SP | $(SP) \leftarrow (H:X) - 1$ | - | - | - | - | - | - | INH | 94 | | 2 |
| WAIT | Enable Interrupts; Wait for Interrupt | I bit ← 0; Inhibit CPU clocking until interrupted | - | - | 0 | - | - | - | INH | 8F | | 1 |

- | | | | |
|-------|---|------------|---|
| A | Accumulator | <i>n</i> | Any bit |
| C | Carry/borrow bit | <i>opr</i> | Operand (one or two bytes) |
| CCR | Condition code register | PC | Program counter |
| dd | Direct address of operand | PCH | Program counter high byte |
| dd rr | Direct address of operand and relative offset of branch instruction | PCL | Program counter low byte |
| DD | Direct to direct addressing mode | REL | Relative addressing mode |
| DIR | Direct addressing mode | <i>rel</i> | Relative program counter offset byte |
| DIX+ | Direct to indexed with post increment addressing mode | <i>rr</i> | Relative program counter offset byte |
| ee ff | High and low bytes of offset in indexed, 16-bit offset addressing | SP1 | Stack pointer, 8-bit offset addressing mode |
| EXT | Extended addressing mode | SP2 | Stack pointer 16-bit offset addressing mode |
| ff | Offset byte in indexed, 8-bit offset addressing | SP | Stack pointer |
| H | Half-carry bit | U | Undefined |
| H | Index register high byte | V | Overflow bit |
| hh ll | High and low bytes of operand address in extended addressing | X | Index register low byte |
| I | Interrupt mask | Z | Zero bit |
| ii | Immediate operand byte | & | Logical AND |
| IMD | Immediate source to direct destination addressing mode | | Logical OR |
| IMM | Immediate addressing mode | ⊕ | Logical EXCLUSIVE OR |
| INH | Inherent addressing mode | () | Contents of |
| IX | Indexed, no offset addressing mode | (-) | Negation (two's complement) |
| IX+ | Indexed, no offset, post increment addressing mode | # | Immediate value |
| IX+D | Indexed with post increment to direct addressing mode | « | Sign extend |
| IX1 | Indexed, 8-bit offset addressing mode | ← | Loaded with |
| IX1+ | Indexed, 8-bit offset, post increment addressing mode | ? | If |
| IX2 | Indexed, 16-bit offset addressing mode | : | Concatenated with |
| M | Memory location | † | Set or cleared |
| N | Negative bit | — | Not affected |

5.8 Opcode Map

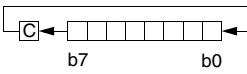
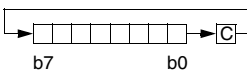
See [Table 5-2](#).

Table 5-2. Opcode Map

| MSB LSB | Bit Manipulation | | Branch | Read-Modify-Write | | | | | | Control | | Register/Memory | | | | | | | |
|------------|------------------|----------------|---------------|-------------------|----------------|----------------|----------------|---------------|---------------|---------------|--------------|-----------------|--------------|--------------|--------------|--------------|--------------|--------------|-------------|
| | DIR | DIR | REL | DIR | INH | INH | IX1 | SP1 | IX | INH | INH | IMM | DIR | EXT | IX2 | SP2 | IX1 | SP1 | IX |
| | 0 | 1 | 2 | 3 | 4 | 5 | 6 | 9E6 | 7 | 8 | 9 | A | B | C | D | 9ED | E | 9EE | F |
| 0 | BRSET0 3 DIR | BSET0 2 DIR | BRA 2 REL | NEG 2 DIR | NEGA 1 INH | NEGX 1 INH | NEG 2 IX1 | NEG 3 SP1 | NEG 1 IX | RTI 1 INH | BGE 2 REL | SUB 2 IMM | SUB 2 DIR | SUB 3 EXT | SUB 3 IX2 | SUB 4 SP2 | SUB 2 IX1 | SUB 3 SP1 | SUB 1 IX |
| 1 | BRCLR0 3 DIR | BCLR0 2 DIR | BRN 2 REL | CBEQ 3 DIR | CBEQA 3 IMM | CBEQX 3 IMM | CBEQ 3 IX1+ | CBEQ 4 SP1 | CBEQ 2 IX+ | RTS 1 INH | BLT 2 REL | CMP 2 IMM | CMP 2 DIR | CMP 3 EXT | CMP 3 IX2 | CMP 4 SP2 | CMP 2 IX1 | CMP 3 SP1 | CMP 1 IX |
| 2 | BRSET1 3 DIR | BSET1 2 DIR | BHI 2 REL | | MUL 1 INH | DIV 1 INH | NSA 1 INH | | DAA 1 INH | | BGT 2 REL | SBC 2 IMM | SBC 2 DIR | SBC 3 EXT | SBC 3 IX2 | SBC 4 SP2 | SBC 2 IX1 | SBC 3 SP1 | SBC 1 IX |
| 3 | BRCLR1 3 DIR | BCLR1 2 DIR | BLS 2 REL | COM 2 DIR | COMA 1 INH | COMX 1 INH | COM 2 IX1 | COM 3 SP1 | COM 1 IX | SWI 1 INH | BLE 2 REL | CPX 2 IMM | CPX 2 DIR | CPX 3 EXT | CPX 3 IX2 | CPX 4 SP2 | CPX 2 IX1 | CPX 3 SP1 | CPX 1 IX |
| 4 | BRSET2 3 DIR | BSET2 2 DIR | BCC 2 REL | LSR 2 DIR | LSRA 1 INH | LSRX 1 INH | LSR 2 IX1 | LSR 3 SP1 | LSR 1 IX | TAP 1 INH | TXS 1 INH | AND 2 IMM | AND 2 DIR | AND 3 EXT | AND 3 IX2 | AND 4 SP2 | AND 2 IX1 | AND 3 SP1 | AND 1 IX |
| 5 | BRCLR2 3 DIR | BCLR2 2 DIR | BCS 2 REL | STHX 2 DIR | LDHX 3 IMM | LDHX 2 DIR | CPHX 3 IMM | | CPHX 2 DIR | TPA 1 INH | TSX 1 INH | BIT 2 IMM | BIT 2 DIR | BIT 3 EXT | BIT 3 IX2 | BIT 4 SP2 | BIT 2 IX1 | BIT 3 SP1 | BIT 1 IX |
| 6 | BRSET3 3 DIR | BSET3 2 DIR | BNE 2 REL | ROR 2 DIR | RORA 1 INH | RORX 1 INH | ROR 2 IX1 | ROR 3 SP1 | ROR 1 IX | PULA 1 INH | | LDA 2 IMM | LDA 2 DIR | LDA 3 EXT | LDA 3 IX2 | LDA 4 SP2 | LDA 2 IX1 | LDA 3 SP1 | LDA 1 IX |
| 7 | BRCLR3 3 DIR | BCLR3 2 DIR | BEQ 2 REL | ASR 2 DIR | ASRA 1 INH | ASRX 1 INH | ASR 2 IX1 | ASR 3 SP1 | ASR 1 IX | PSHA 1 INH | TAX 1 INH | AIS 2 IMM | STA 2 DIR | STA 3 EXT | STA 3 IX2 | STA 4 SP2 | STA 2 IX1 | STA 3 SP1 | STA 1 IX |
| 8 | BRSET4 3 DIR | BSET4 2 DIR | BHCC 2 REL | LSL 2 DIR | LSLA 1 INH | LSLX 1 INH | LSL 2 IX1 | LSL 3 SP1 | LSL 1 IX | PULX 1 INH | CLC 1 INH | EOR 2 IMM | EOR 2 DIR | EOR 3 EXT | EOR 3 IX2 | EOR 4 SP2 | EOR 2 IX1 | EOR 3 SP1 | EOR 1 IX |
| 9 | BRCLR4 3 DIR | BCLR4 2 DIR | BHCS 2 REL | ROL 2 DIR | ROLA 1 INH | ROLX 1 INH | ROL 2 IX1 | ROL 3 SP1 | ROL 1 IX | PSHX 1 INH | SEC 1 INH | ADC 2 IMM | ADC 2 DIR | ADC 3 EXT | ADC 3 IX2 | ADC 4 SP2 | ADC 2 IX1 | ADC 3 SP1 | ADC 1 IX |
| A | BRSET5 3 DIR | BSET5 2 DIR | BPL 2 REL | DEC 2 DIR | DECA 1 INH | DECX 1 INH | DEC 2 IX1 | DEC 3 SP1 | DEC 1 IX | PULH 1 INH | CLI 1 INH | ORA 2 IMM | ORA 2 DIR | ORA 3 EXT | ORA 3 IX2 | ORA 4 SP2 | ORA 2 IX1 | ORA 3 SP1 | ORA 1 IX |
| B | BRCLR5 3 DIR | BCLR5 2 DIR | BMI 2 REL | DBNZ 3 DIR | DBNZA 2 INH | DBNZX 2 INH | DBNZ 3 IX1 | DBNZ 4 SP1 | DBNZ 2 IX | PSHH 1 INH | SEI 1 INH | ADD 2 IMM | ADD 2 DIR | ADD 3 EXT | ADD 3 IX2 | ADD 4 SP2 | ADD 2 IX1 | ADD 3 SP1 | ADD 1 IX |
| C | BRSET6 3 DIR | BSET6 2 DIR | BMC 2 REL | INC 2 DIR | INCA 1 INH | INCX 1 INH | INC 2 IX1 | INC 3 SP1 | INC 1 IX | CLRH 1 INH | RSP 1 INH | | JMP 2 DIR | JMP 3 EXT | JMP 3 IX2 | | JMP 2 IX1 | | JMP 1 IX |
| D | BRCLR6 3 DIR | BCLR6 2 DIR | BMS 2 REL | TST 2 DIR | TSTA 1 INH | TSTX 1 INH | TST 2 IX1 | TST 3 SP1 | TST 1 IX | | NOP 1 INH | BSR 2 REL | JSR 2 DIR | JSR 3 EXT | JSR 3 IX2 | | JSR 2 IX1 | | JSR 1 IX |
| E | BRSET7 3 DIR | BSET7 2 DIR | BIL 2 REL | | MOV 3 DD | MOV 2 DIX+ | MOV 3 IMD | | MOV 2 IX+D | STOP 1 INH | * | LDX 2 IMM | LDX 2 DIR | LDX 3 EXT | LDX 3 IX2 | LDX 4 SP2 | LDX 2 IX1 | LDX 3 SP1 | LDX 1 IX |
| F | BRCLR7 3 DIR | BCLR7 2 DIR | BIH 2 REL | CLR 2 DIR | CLRA 1 INH | CLRX 1 INH | CLR 2 IX1 | CLR 3 SP1 | CLR 1 IX | WAIT 1 INH | TXA 1 INH | AIX 2 IMM | STX 2 DIR | STX 3 EXT | STX 3 IX2 | STX 4 SP2 | STX 2 IX1 | STX 3 SP1 | STX 1 IX |

INH Inherent
 IMM Immediate
 DIR Direct
 EXT Extended
 DD Direct-Direct
 IX+D Indexed-Direct
 REL Relative
 IX Indexed, No Offset
 IX1 Indexed, 8-Bit Offset
 IX2 Indexed, 16-Bit Offset
 IMM Direct-Immediate
 DIX+ Direct-Indexed
 SP1 Stack Pointer, 8-Bit Offset
 SP2 Stack Pointer, 16-Bit Offset
 IX+ Indexed, No Offset with Post Increment
 IX1+ Indexed, 1-Byte Offset with Post Increment

*Pre-byte for stack pointer indexed instructions

Low Byte of Opcode in Hexadecimal

| | |
|-----|----------------------|
| MSB | 0 |
| LSB | 5 BRSET0 3 DIR |

High Byte of Opcode in Hexadecimal
 Cycles
 Opcode Mnemonic
 Number of Bytes / Addressing Mode

Chapter 6

System Integration Module (SIM)

6.1 Introduction

This section describes the system integration module (SIM24, version C), which supports up to 24 external and/or internal interrupts. Together with the CPU, the SIM controls all MCU activities. A block diagram of the SIM is shown in [Figure 6-1](#). [Figure 6-2](#) is a summary of the SIM I/O (input/output) registers. The SIM is a system state controller that coordinates CPU and exception timing. The SIM is responsible for:

- Bus clock generation and control for CPU and peripherals:
 - Stop/wait/reset/break entry and recovery
 - Internal clock control
- Master reset control, including power-on reset (POR) and COP timeout
- Interrupt control:
 - Acknowledge timing
 - Arbitration control timing
 - Vector address generation
- CPU enable/disable timing
- Modular architecture expandable to 128 interrupt sources

NOTE

All references to LVI and DMA and stop mode operation in this section should be ignored.

[Table 6-1](#) shows the internal signal names used in this section.

Table 6-1. Signal Name Conventions

| Signal name | Description |
|-------------------|---|
| CGMXCLK | Buffered version of OSC1 from clock generator module (CGM) |
| CGMVCLK | PLL output |
| CGMOUT | PLL-based or OSC1-based clock output from CGM module (Bus clock = CGMOUT divided by two) |
| IAB | Internal address bus |
| IDB | Internal data bus |
| PORRST | Signal from the power-on reset module to the SIM |
| IRST | Internal reset signal |
| R/ \overline{W} | Read/write signal |

System Integration Module (SIM)

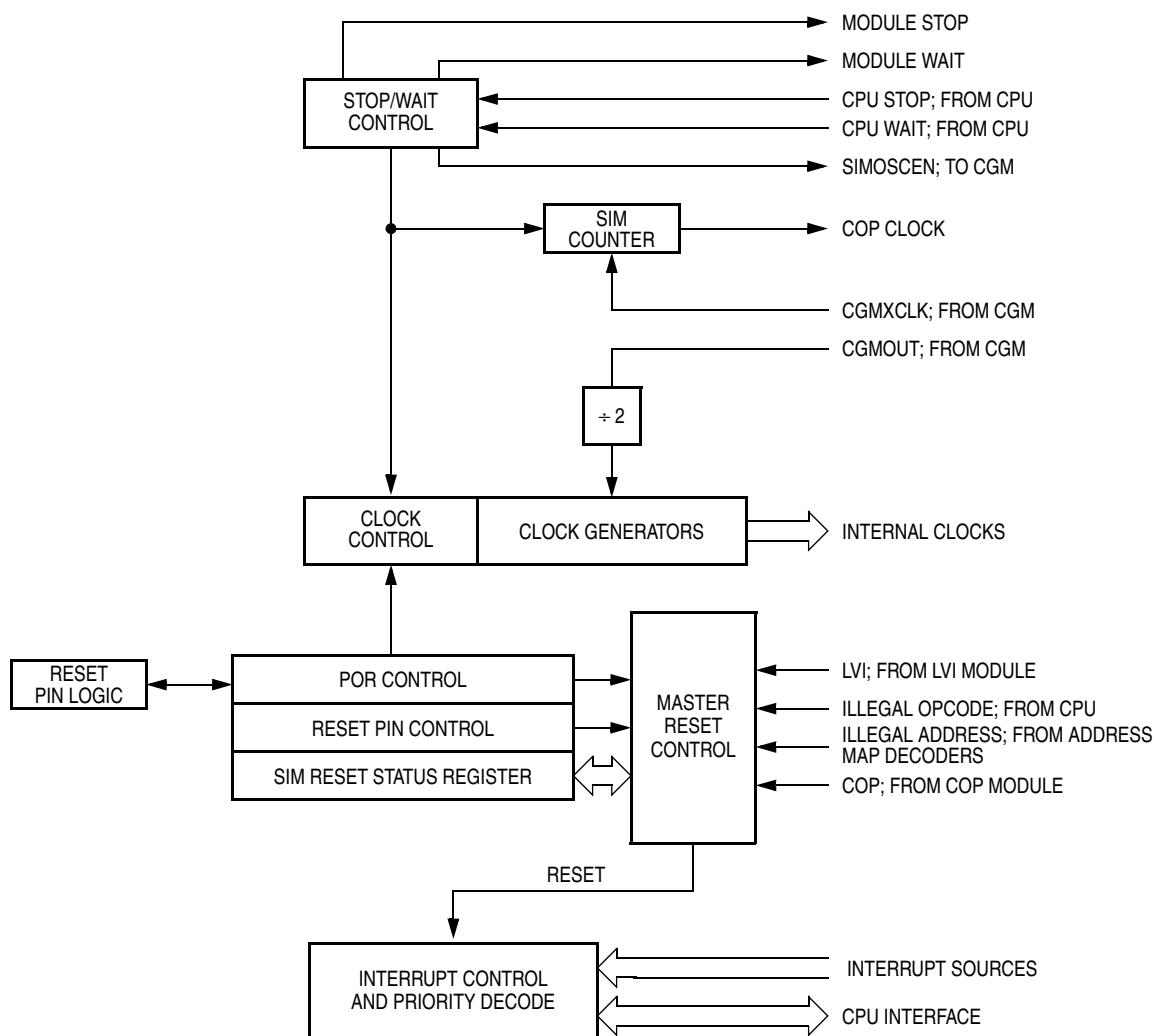

Figure 6-1. SIM Block Diagram

| Addr. | Register Name | Bit 7 | 6 | 5 | 4 | 3 | 2 | 1 | Bit 0 | |
|--------|---|--------|------|-----|-----|------|------|--------|-------|---|
| \$FE00 | SIM Break Status Register (SBSR) | Read: | R | R | R | R | R | SBSW | R | |
| | | Write: | | | | | | Note 1 | | |
| | | Reset: | 0 | | | | | | | |
| \$FE01 | SIM Reset Status Register (SRSR) | Read: | POR | PIN | COP | ILOP | ILAD | 0 | LVI | 0 |
| | | Write: | | | | | | | | |
| | | Reset: | 1 | 0 | 0 | 0 | 0 | 0 | 0 | 0 |
| \$FE03 | SIM Break Flag Control Register (SBFCR) | Read: | BCFE | R | R | R | R | R | R | R |
| | | Write: | | | | | | | | |
| | | Reset: | 0 | | | | | | | |

Note 1. Writing a logic 0 clears SBSW.

R = Reserved = Unimplemented

Figure 6-2. SIM I/O Register Summary

6.2 SIM Bus Clock Control and Generation

The bus clock generator provides system clock signals for the CPU and peripherals on the MCU. The system clocks are generated from an incoming clock, CGMOUT, as shown in Figure 6-3. This clock can come from either an external oscillator or from the on-chip PLL. (See 7.1 Introduction.)

6.2.1 Bus Timing

In user mode, the internal bus frequency is either the crystal oscillator output (CGMXCLK) divided by four or the PLL output (CGMVCLK) divided by four. (See 7.1 Introduction.)

6.2.2 Clock Startup from POR or LVI Reset

When the power-on reset module or the low-voltage inhibit module generates a reset, the clocks to the CPU and peripherals are inactive and held in an inactive phase until after the 4096 CGMXCLK cycle POR timeout has completed. The \overline{RST} pin is driven low by the SIM during this entire period. The IBUS clocks start upon completion of the timeout.

NOTE

The MC68HC(9)08LK60 does not have an LVI module.

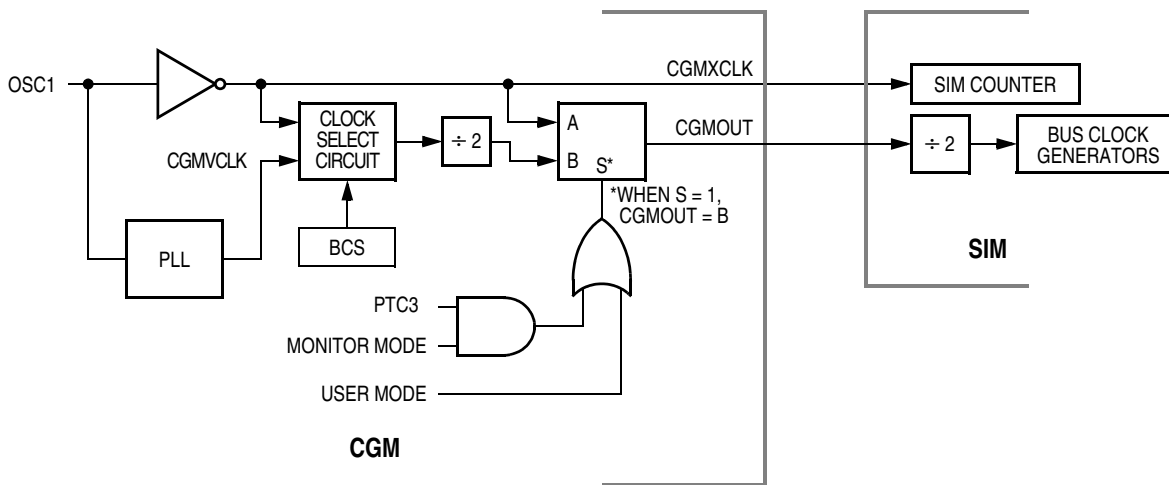

Figure 6-3. CGM Clock Signals

6.2.3 Clocks in Stop Mode and Wait Mode

Upon exit from stop mode (by an interrupt, break, or reset), the SIM allows CGMXCLK to clock the SIM counter. The CPU and peripheral clocks do not become active until after the stop delay timeout. This timeout is selectable as 4096 or 32 CGMXCLK cycles. (See 6.6.2 Stop Mode.)

NOTE

The MC68HC(9)08LK60 does not allow stop mode operation.

In wait mode, the CPU clocks are inactive. The SIM also produces two sets of clocks for other modules. Refer to the wait mode subsection of each module to see if the module is active or inactive in wait mode. Some modules can be programmed to be active in wait mode.

6.3 Reset and System Initialization

The MCU has these reset sources:

- Power-on reset module (POR)
- External reset pin ($\overline{\text{RST}}$)
- Computer operating properly module (COP)
- Low-voltage inhibit module (LVI)
- Illegal opcode
- Illegal address

All of these resets produce the vector \$FFFE–FFFF (\$FEFE–FEFF in monitor mode) and assert the internal reset signal (IRST). IRST causes all registers to be returned to their default values and all modules to be returned to their reset states.

An internal reset clears the SIM counter (see [6.4 SIM Counter](#)), but an external reset does not. Each of the resets sets a corresponding bit in the SIM reset status register (SRSR). (See [6.7 SIM Registers](#).)

6.3.1 External Pin Reset

Pulling the asynchronous $\overline{\text{RST}}$ pin low halts all processing. The PIN bit of the SIM reset status register (SRSR) is set as long as $\overline{\text{RST}}$ is held low for a minimum of 67 CGMXCLK cycles, assuming that neither the POR nor the LVI was the source of the reset. See [Table 6-2](#) for details. [Figure 6-4](#) shows the relative timing.

Table 6-2. PIN Bit Set Timing

| Reset type | Number of cycles required to set PIN |
|------------|--------------------------------------|
| POR/LVI | 4163 (4096 + 64 + 3) |
| All others | 67 (64 + 3) |

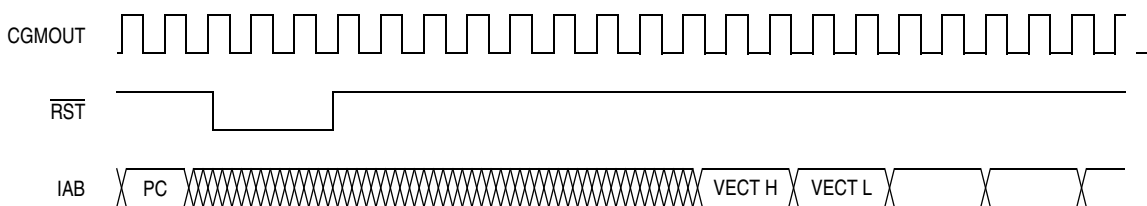

Figure 6-4. External Reset Timing

6.3.2 Active Resets from Internal Sources

All internal reset sources actively pull the $\overline{\text{RST}}$ pin low for 32 CGMXCLK cycles to allow resetting of external peripherals. The internal reset signal IRST continues to be asserted for an additional 32 cycles. (See Figure 6-5.) An internal reset can be caused by an illegal address, illegal opcode, COP timeout, LVI, or POR. (See Figure 6-6.) Note that for LVI or POR resets, the SIM cycles through 4096 CGMXCLK cycles during which the SIM forces the $\overline{\text{RST}}$ pin low. The internal reset signal then follows the sequence from the falling edge of $\overline{\text{RST}}$ shown in Figure 6-5.

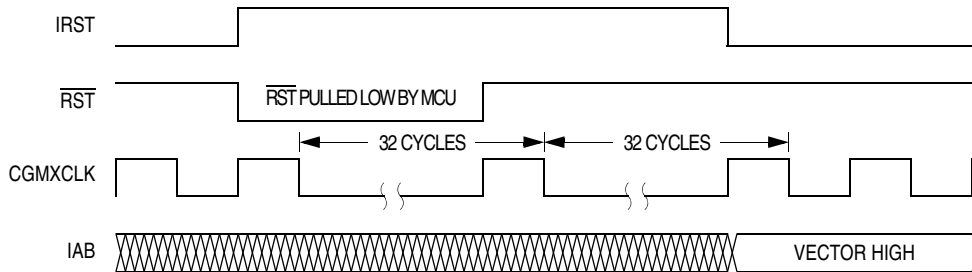

Figure 6-5. Internal Reset Timing

The COP reset is asynchronous to the bus clock.

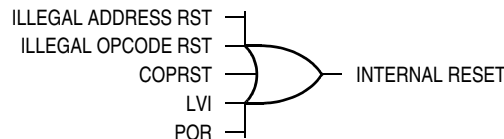

Figure 6-6. Sources of Internal Reset

The active reset feature allows the part to issue a reset to peripherals and other chips within a system built around the MCU.

6.3.2.1 Power-On Reset

When power is first applied to the MCU, the power-on reset module (POR) generates a pulse to indicate that power-on has occurred. The external reset pin ($\overline{\text{RST}}$) is held low while the SIM counter counts out 4096 CGMXCLK cycles. Sixty-four CGMXCLK cycles later, the CPU and memories are released from reset to allow the reset vector sequence to occur.

At power-on, these events occur:

- A POR pulse is generated.
- The internal reset signal is asserted.
- The SIM enables CGMOUT.
- Internal clocks to the CPU and modules are held inactive for 4096 CGMXCLK cycles to allow stabilization of the oscillator.
- The $\overline{\text{RST}}$ pin is driven low during the oscillator stabilization time.
- The POR bit of the SIM reset status register (SRSR) is set and all other bits in the register are cleared.

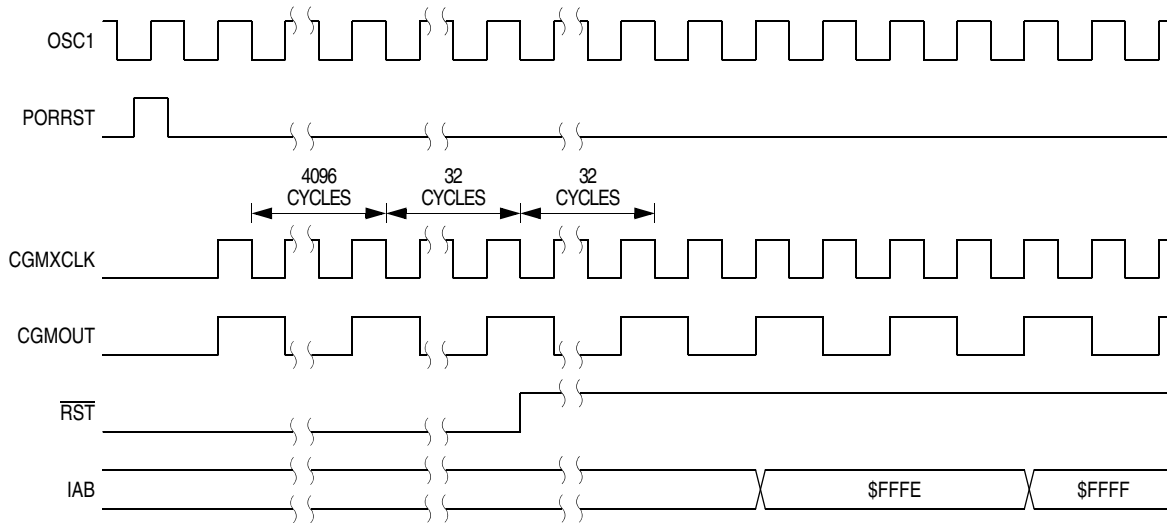

Figure 6-7. POR Recovery

6.3.2.2 Computer Operating Properly (COP) Reset

An input to the SIM is reserved for the COP reset signal. The overflow of the COP counter causes an internal reset and sets the COP bit in the SIM reset status register (SRSR). The SIM actively pulls down the $\overline{\text{RST}}$ pin for all internal reset sources.

To prevent a COP module timeout, write any value to location \$FFFF. Writing to location \$FFFF clears the COP counter and bits 12 through 4 of the SIM counter. The SIM counter output, which occurs at least every $2^{13} - 2^4$ CGMXCLK cycles, drives the COP counter. The COP should be serviced as soon as possible out of reset to guarantee the maximum amount of time before the first timeout.

The COP module is disabled if the $\overline{\text{RST}}$ pin or the $\overline{\text{IRQ1}}$ pin is held at $V_{\text{DD}} + V_{\text{HI}}$ while the MCU is in monitor mode. The COP module can be disabled only through combinational logic conditioned with the high voltage signal on the $\overline{\text{RST}}$ or the $\overline{\text{IRQ1}}$ pin. This prevents the COP from becoming disabled as a result of external noise. During a break state, $V_{\text{DD}} + V_{\text{HI}}$ on the $\overline{\text{RST}}$ pin disables the COP module.

6.3.2.3 Illegal Opcode Reset

The SIM decodes signals from the CPU to detect illegal instructions. An illegal instruction sets the ILOP bit in the SIM reset status register (SRSR) and causes a reset.

If the stop enable bit, STOP, in the mask option register is logic 0, the SIM treats the STOP instruction as an illegal opcode and causes an illegal opcode reset. The SIM actively pulls down the $\overline{\text{RST}}$ pin for all internal reset sources.

6.3.2.4 Illegal Address Reset

An opcode fetch from an unmapped address generates an illegal address reset. The SIM verifies that the CPU is fetching an opcode prior to asserting the ILAD bit in the SIM reset status register (SRSR) and resetting the MCU. A data fetch from an unmapped address does not generate a reset. The SIM actively pulls down the $\overline{\text{RST}}$ pin for all internal reset sources.

6.3.2.5 Low-Voltage Inhibit (LVI) Reset

The low-voltage inhibit module (LVI) asserts its output to the SIM when the V_{DD} voltage falls to the LVI_{TRIPF} voltage. The LVI bit in the SIM reset status register (SRSR) is set, and the external reset pin (\overline{RST}) is held low while the SIM counter counts out 4096 CGMXCLK cycles. Sixty-four CGMXCLK cycles later, the CPU is released from reset to allow the reset vector sequence to occur. The SIM actively pulls down the \overline{RST} pin for all internal reset sources.

NOTE

The MC68HC(9)08LK60 does not have an LVI module.

6.4 SIM Counter

The SIM counter is used by the power-on reset module (POR) and in stop mode recovery to allow the oscillator time to stabilize before enabling the internal bus (IBUS) clocks. The SIM counter also serves as a prescaler for the computer operating properly module (COP). The SIM counter overflow supplies the clock for the COP module. The SIM counter is 13 bits long and is clocked by the falling edge of CGMXCLK.

6.4.1 SIM Counter During Power-On Reset

The power-on reset module (POR) detects power applied to the MCU. At power-on, the POR circuit asserts the signal PORRST. Once the SIM is initialized, it enables the clock generation module (CGM) to drive the bus clock state machine.

6.4.2 SIM Counter During Stop Mode Recovery

The SIM counter also is used for stop mode recovery. The STOP instruction clears the SIM counter. After an interrupt, break, or reset, the SIM senses the state of the short stop recovery bit, SSREC, in the mask option register. If the SSREC bit is a logic 1, then the stop recovery is reduced from the normal delay of 4096 CGMXCLK cycles down to 32 CGMXCLK cycles. This is ideal for applications using canned oscillators that do not require long startup times from stop mode. External crystal applications should use the full stop recovery time, that is, with SSREC cleared.

NOTE

The MC68HC(9)08LK60 does not allow stop mode operation.

6.4.3 SIM Counter and Reset States

External reset has no effect on the SIM counter. (See [6.6.2 Stop Mode](#) for details.) The SIM counter is free-running after all reset states. (See [6.3.2 Active Resets from Internal Sources](#) for counter control and internal reset recovery sequences.)

6.5 Exception Control

Normal, sequential program execution can be changed in three different ways:

- Interrupts:
 - Maskable hardware CPU interrupts
 - Non-maskable software interrupt instruction (SWI)
- Reset
- Break interrupts

6.5.1 Interrupts

At the beginning of an interrupt, the CPU saves the CPU register contents on the stack and sets the interrupt mask (I bit) to prevent additional interrupts. At the end of an interrupt, the RTI instruction recovers the CPU register contents from the stack so that normal processing can resume. [Figure 6-8](#) shows interrupt entry timing. [Figure 6-9](#) shows interrupt recovery timing.

Interrupts are latched, and arbitration is performed in the SIM at the start of interrupt processing. The arbitration result is a constant that the CPU uses to determine which vector to fetch. Once an interrupt is latched by the SIM, no other interrupt may take precedence, regardless of priority, until the latched interrupt is serviced (or the I bit is cleared). (See [Figure 6-10](#).)

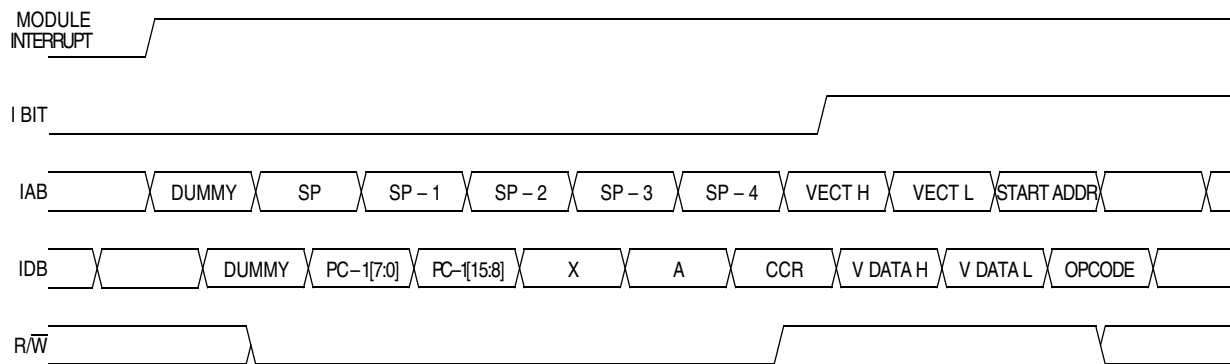

Figure 6-8. Interrupt Entry

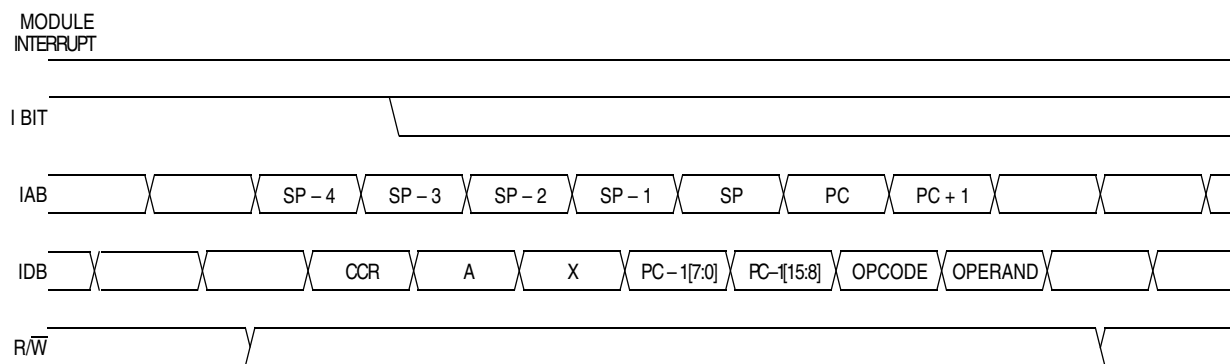

Figure 6-9. Interrupt Recovery

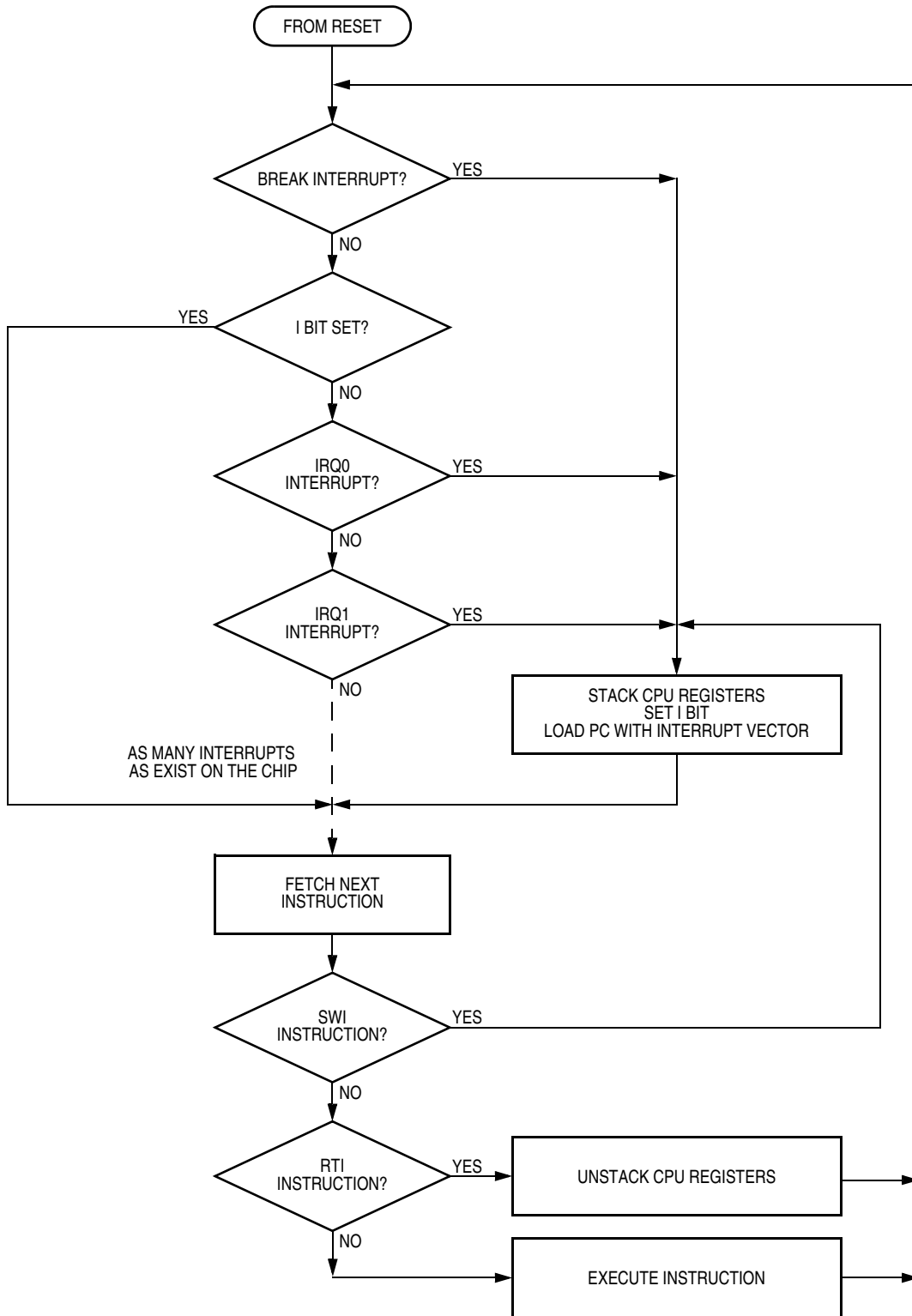

Figure 6-10. Interrupt Processing

6.5.1.1 Hardware Interrupts

A hardware interrupt does not stop the current instruction. Processing of a hardware interrupt begins after completion of the current instruction. When the current instruction is complete, the SIM checks all pending hardware interrupts. If interrupts are not masked (I bit clear in the condition code register), and if the corresponding interrupt enable bit is set, the SIM proceeds with interrupt processing; otherwise, the next instruction is fetched and executed.

If more than one interrupt is pending at the end of an instruction execution, the highest priority interrupt is serviced first. Figure 6-11 demonstrates what happens when two interrupts are pending. If an interrupt is pending upon exit from the original interrupt service routine, the pending interrupt is serviced before the LDA instruction is executed.

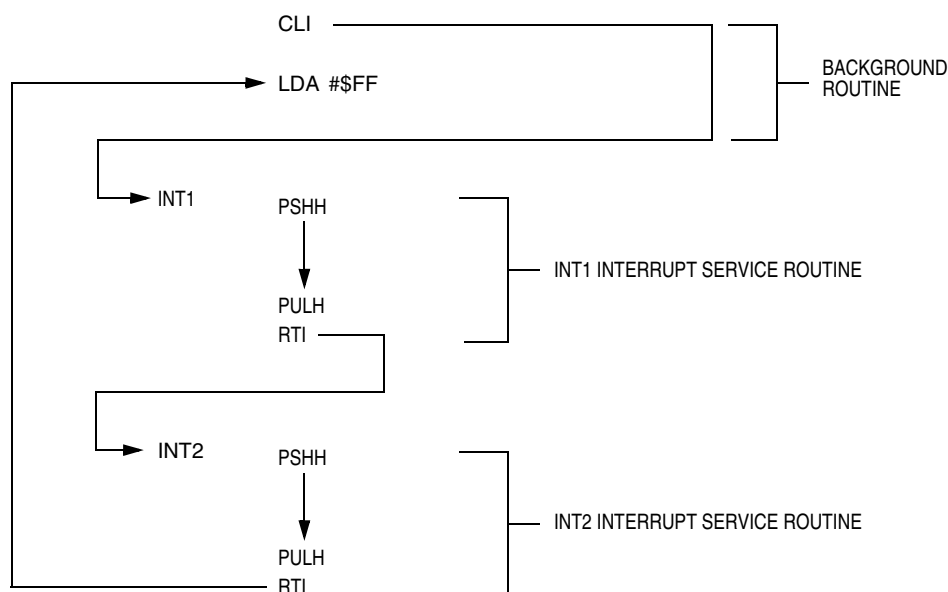

Figure 6-11. Interrupt Recognition Example

The LDA opcode is prefetched by both the INT1 and INT2 RTI instructions. However, in the case of the INT1 RTI prefetch, this is a redundant operation.

NOTE

To maintain compatibility with the M6805 Family, the H register is not pushed on the stack during interrupt entry. If the interrupt service routine modifies the H register or uses the indexed addressing mode, software should save the H register and then restore it prior to exiting the routine.

6.5.1.2 SWI Instruction

The SWI instruction is a non-maskable instruction that causes an interrupt regardless of the state of the interrupt mask (I bit) in the condition code register.

NOTE

A software interrupt pushes PC onto the stack. A software interrupt does not push PC - 1, as a hardware interrupt does.

6.5.2 Reset

All reset sources always have equal and highest priority and cannot be arbitrated.

6.5.3 Break Interrupts

The break module can stop normal program flow at a software-programmable break point by asserting its break interrupt output. (See [Chapter 9 Break Module](#).) The SIM puts the CPU into the break state by forcing it to the SWI vector location. Refer to the break interrupt subsection of each module to see how each module is affected by the break state.

6.5.4 Status Flag Protection in Break Mode

The SIM controls whether status flags contained in other modules can be cleared during break mode. The user can select whether flags are protected from being cleared by properly initializing the break clear flag enable bit (BCFE) in the SIM break flag control register (SBFCR).

Protecting flags in break mode ensures that set flags will not be cleared while in break mode. This protection allows registers to be freely read and written during break mode without losing status flag information.

Setting the BCFE bit enables the clearing mechanisms. Once cleared in break mode, a flag remains cleared even when break mode is exited. Status flags with a 2-step clearing mechanism — for example, a read of one register followed by the read or write of another — are protected, even when the first step is accomplished prior to entering break mode. Upon leaving break mode, execution of the second step will clear the flag as normal.

6.6 Low-Power Modes

Executing the WAIT or STOP instruction puts the MCU in a low-power-consumption mode for standby situations. The SIM holds the CPU in a non-clocked state. The operation of each of these modes is described in the following paragraphs. Both STOP and WAIT clear the interrupt mask (I) in the condition code register, allowing interrupts to occur.

NOTE

The MC68HC(9)08LK60 does not allow stop mode operation.

6.6.1 Wait Mode

In wait mode, the CPU clocks are inactive while the peripheral clocks continue to run. [Figure 6-12](#) shows the timing for wait mode entry.

A module that is active during wait mode can wake up the CPU with an interrupt if the interrupt is enabled. Stacking for the interrupt begins one cycle after the WAIT instruction during which the interrupt occurred. In wait mode, the CPU clocks are inactive. Refer to the wait mode subsection of each module to see if the module is active or inactive in wait mode. Some modules can be programmed to be active in wait mode.

Wait mode also can be exited by a reset or break. A break interrupt during wait mode sets the SIM break stop/wait bit, SBSW, in the SIM break status register (SBSR). If the COP disable bit, COPD, in the mask option register is logic 0, then the computer operating properly module (COP) is enabled and remains active in wait mode.

System Integration Module (SIM)

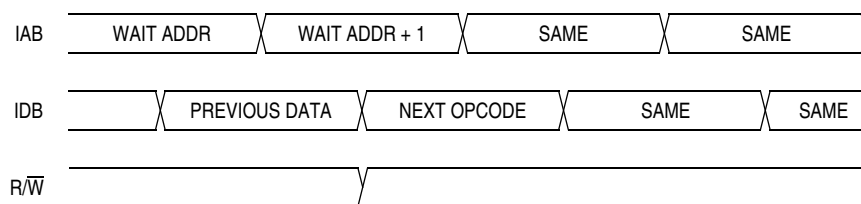

NOTE: Previous data can be operand data or the WAIT opcode, depending on the last instruction.

Figure 6-12. Wait Mode Entry Timing

Figure 6-13 and Figure 6-14 show the timing for WAIT recovery.

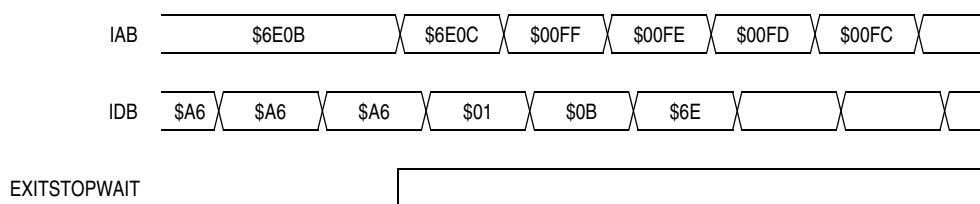

NOTE: EXITSTOPWAIT = $\overline{\text{RST}}$ pin OR CPU interrupt OR break interrupt

Figure 6-13. Wait Recovery from Interrupt or Break

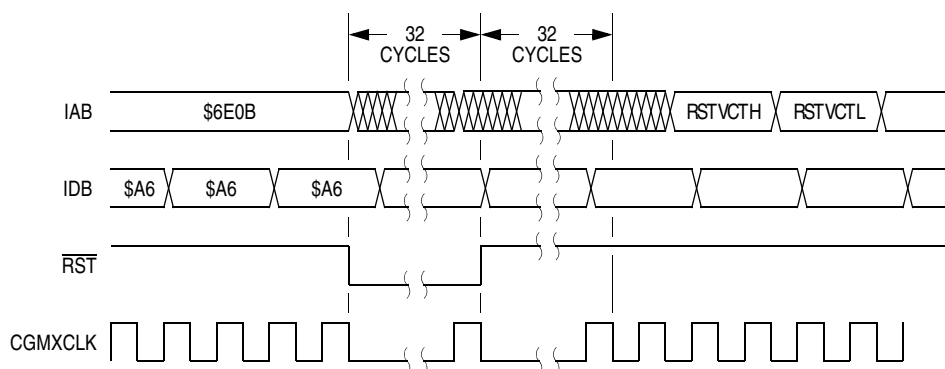

Figure 6-14. Wait Recovery from Internal Reset

6.6.2 Stop Mode

NOTE

The MC68HC(9)08LK60 does not allow stop mode operation.

In stop mode, the SIM counter is reset and the system clocks are disabled. An interrupt request from a module can cause an exit from stop mode. Stacking for interrupts begins after the selected stop recovery time has elapsed. Reset or break also causes an exit from stop mode.

The SIM disables the clock generator module outputs (CGMOUT and CGMXCLK) in stop mode, stopping the CPU and peripherals. Stop recovery time is selectable using the SSREC bit in the mask option register (MOR). If SSREC is set, stop recovery is reduced from the normal delay of 4096 CGMXCLK cycles down to 32. This is ideal for applications using canned oscillators that do not require long startup times from stop mode.

NOTE

External crystal applications should use the full stop recovery time by clearing the SSREC bit.

A break interrupt during stop mode sets the SIM break stop/wait bit (SBSW) in the SIM break status register (SBSR).

The SIM counter is held in reset from the execution of the STOP instruction until the beginning of stop recovery. It is then used to time the recovery period. Figure 6-15 shows stop mode entry timing.

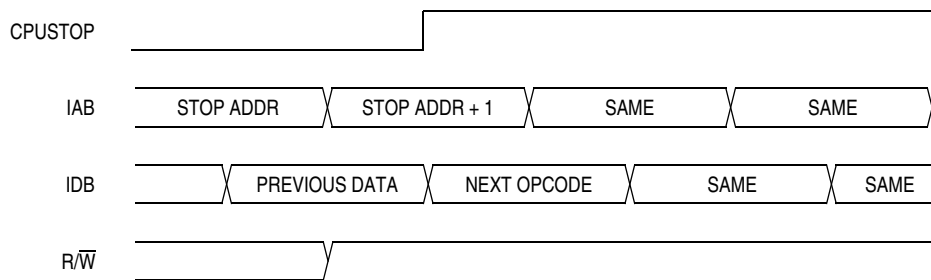

NOTE: Previous data can be operand data or the STOP opcode, depending on the last instruction.

Figure 6-15. Stop Mode Entry Timing

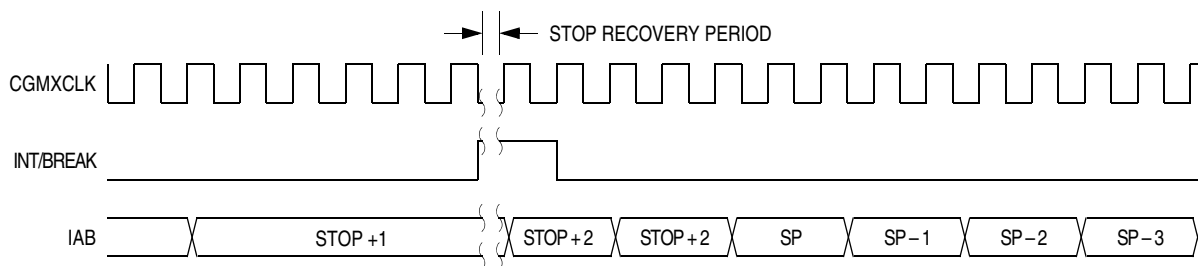

Figure 6-16. Stop Mode Recovery from Interrupt or Break

6.7 SIM Registers

The SIM has three memory mapped registers. Table 6-3 shows the mapping of these registers.

Table 6-3. SIM Registers

| Address | Register | Access mode |
|---------|---|-------------|
| \$FE00 | SBSR — SIM break status register | User |
| \$FE01 | SRSR — SIM reset status register | User |
| \$FE03 | SBFCR — SIM break flag control register | User |

6.7.1 SIM Break Status Register

The SIM break status register contains a flag to indicate that a break caused an exit from stop or wait mode.

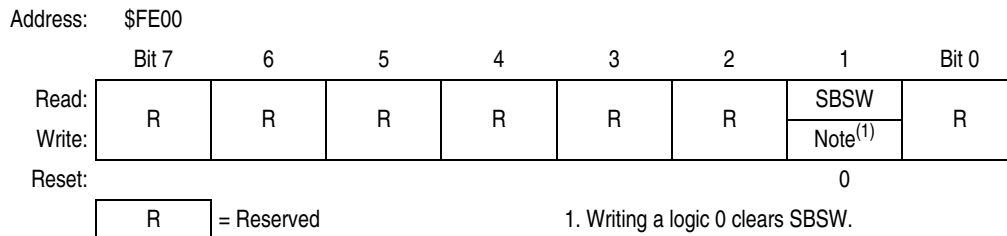

Figure 6-17. SIM Break Status Register (SBSR)

SBSW — SIM break stop/wait bit

This status bit is useful in applications requiring a return to wait or stop mode after exiting from a break interrupt. Clear SBSW by writing a logic 0 to it. Reset clears SBSW.

- 1 = Stop mode or wait mode was exited by break interrupt.
- 0 = Stop mode or wait mode was not exited by break interrupt.

SBSW can be read within the break state SWI routine. The user can modify the return address on the stack by subtracting one from it. The following code is an example of this. Writing 0 to the SBSW bit clears it.

```

; This code works if the H register has been pushed onto the stack in the break
; service routine software. This code should be executed at the end of the
; break service routine software.

HIBYTE EQU 5
LOBYTE EQU 6
; If not SBSW, do RTI
BRCLR SBSW,SBSR, RETURN ; See if wait mode or stop mode was exited
; by break.
TST LOBYTE,SP ; If RETURNLO is not zero,
BNE DOLO ; then just decrement low byte.
DEC HIBYTE,SP ; Else deal with high byte, too.
DOLO DEC LOBYTE,SP ; Point to WAIT/STOP opcode.
RETURN PULH ; Restore H register.
RTI

```

6.7.2 SIM Reset Status Register

This register contains six flags that show the source of the last reset. Clear the SIM reset status register by reading it. A power-on reset sets the POR bit and clears all other bits in the register.

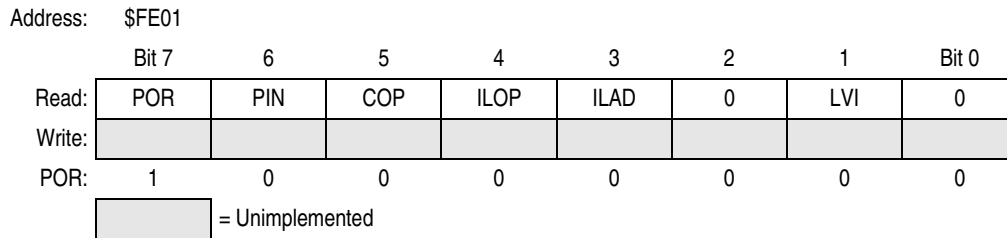

Figure 6-18. SIM Reset Status Register (SRSR)

POR — Power-on reset bit

- 1 = Last reset caused by POR circuit
- 0 = Read of SRSR

PIN — External reset bit

- 1 = Last reset caused by external reset pin (\overline{RST})
- 0 = POR or read of SRSR

COP — Computer operating properly reset bit

- 1 = Last reset caused by COP counter
- 0 = POR or read of SRSR

ILOP — Illegal opcode reset bit

- 1 = Last reset caused by an illegal opcode
- 0 = POR or read of SRSR

ILAD — Illegal address reset bit (opcode fetches only)

- 1 = Last reset caused by an opcode fetch from an illegal address
- 0 = POR or read of SRSR

LVI — Low-voltage inhibit reset bit

- 1 = Last reset caused by the LVI circuit
- 0 = POR or read of SRSR

6.7.3 SIM Break Flag Control Register

The SIM break control register contains a bit that enables software to clear status bits while the MCU is in a break state.

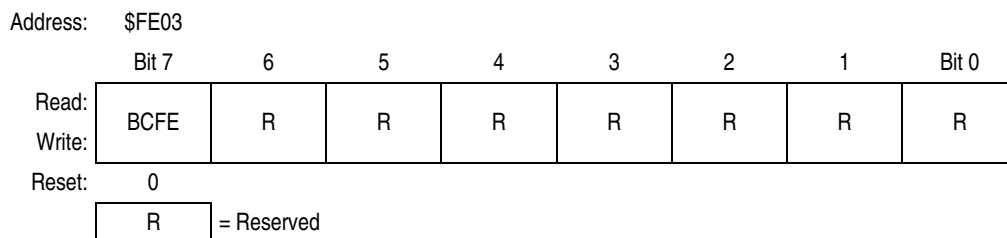

Figure 6-19. SIM Break Flag Control Register (SBFCR)

BCFE — Break clear flag enable bit

This read/write bit enables software to clear status bits by accessing status registers while the MCU is in a break state. To clear status bits during the break state, the BCFE bit must be set.

- 1 = Status bits clearable during break
- 0 = Status bits not clearable during break

Chapter 7

Clock Generator Module (CGMB)

7.1 Introduction

This section describes the clock generator module (CGM, version B). The CGM generates the crystal clock signal, CGMXCLK, which operates at the frequency of the crystal. The CGM also generates the base clock signal, CGMOUT, from which the system integration module (SIM) derives the system clocks. CGMOUT is based on either the crystal clock divided by two or the phase-locked loop (PLL) clock, CGMVCLK, divided by two. The PLL is a fully functional frequency generator designed for use with crystals or ceramic resonators. The PLL can generate a 4-MHz bus frequency without using a 16-MHz crystal.

7.2 Features

Features of the CGMB include:

- Phase-locked loop with output frequency in integer multiples of an integer dividend of the crystal reference
- Low-frequency crystal operation with low-power operation and high-output frequency resolution
- Programmable reference divider for even greater resolution
- Programmable prescaler for power-of-two increases in frequency
- Programmable hardware voltage-controlled oscillator (VCO) for low-jitter operation
- Automatic bandwidth control mode for low-jitter operation
- Automatic frequency lock detector
- CPU interrupt on entry or exit from locked condition

7.3 Functional Description

The CGMB consists of three major submodules:

- Crystal oscillator circuit — The crystal oscillator circuit generates the constant crystal frequency clock, CGMXCLK.
- Phase-locked loop (PLL) — The PLL generates the programmable VCO frequency clock, CGMVCLK.
- Base clock selector circuit — This software-controlled circuit selects either CGMXCLK divided by two or the VCO clock, CGMVCLK, divided by two as the base clock, CGMOUT. The SIM derives the system clocks from CGMOUT.

Figure 7-1 shows the structure of the CGM.

Clock Generator Module (CGMB)

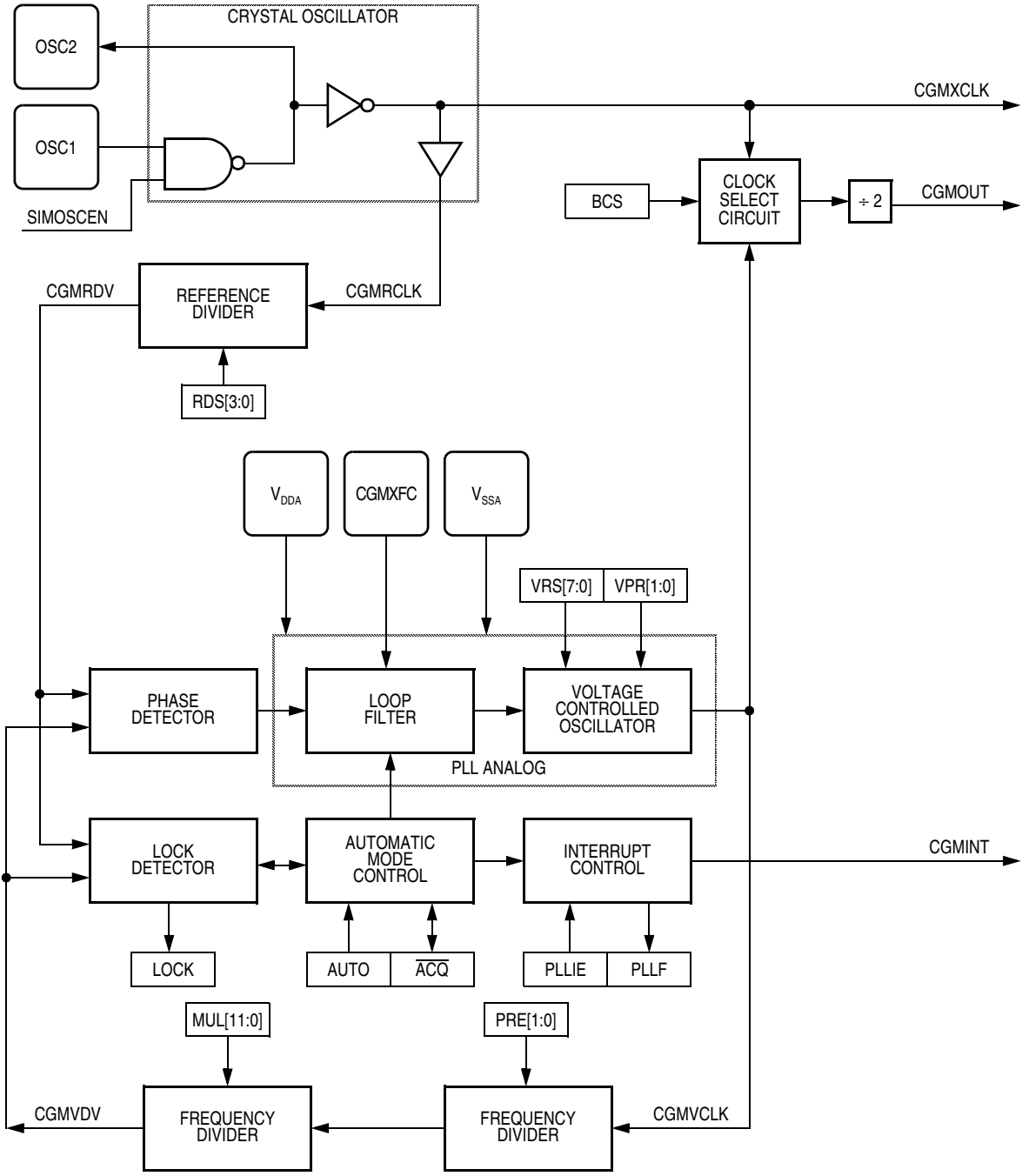

Figure 7-1. CGMB Block Diagram

7.3.1 Crystal Oscillator Circuit

The crystal oscillator circuit consists of an inverting amplifier and an external crystal. The OSC1 pin is the input to the amplifier and the OSC2 pin is the output. The SIMOSCEN signal from the system integration module (SIM) enables the crystal oscillator circuit.

The CGMXCLK signal is the output of the crystal oscillator circuit and runs at a rate equal to the crystal frequency. CGMXCLK is then buffered to produce CGMRCLK, the PLL reference clock.

CGMXCLK can be used by other modules which require precise timing for operation. The duty cycle of CGMXCLK is not guaranteed to be 50% and depends on external factors, including the crystal and related external components.

An externally generated clock also can feed the OSC1 pin of the crystal oscillator circuit. Connect the external clock to the OSC1 pin and let the OSC2 pin float.

7.3.2 Phase-Locked Loop Circuit (PLL)

The PLL is a frequency generator that can operate in either acquisition mode or tracking mode, depending on the accuracy of the output frequency. The PLL can change between acquisition and tracking modes either automatically or manually.

7.3.2.1 PLL Circuits

The PLL consists of:

- Voltage-controlled oscillator (VCO)
- Reference divider
- Frequency prescaler
- Modulo VCO frequency divider
- Phase detector
- Loop filter
- Lock detector

The operating range of the VCO is programmable for a wide range of frequencies and for maximum immunity to external noise, including supply and CGMXFC noise. The VCO frequency is bound to a range from roughly one-half to twice the center-of-range frequency, f_{VRS} . Modulating the voltage on the CGMXFC pin changes the frequency within this range. By design, f_{VRS} is equal to the nominal center-of-range frequency, f_{NOM} , (38.4 kHz) times a linear factor, L, and a power-of-two factor, E, or $(L \times 2^E)f_{NOM}$.

CGMRCLK is the PLL reference clock, a buffered version of CGMXCLK. CGMRCLK runs at a frequency, f_{RCLK} , and is fed to the PLL through a programmable modulo reference divider, which divides f_{RCLK} by a factor R. This feature allows frequency steps of higher resolution. The divider's output is the final reference clock, CGMRDV, running at a frequency $f_{RDV} = f_{RCLK}/R$.

The VCO's output clock, CGMVCLK, running at a frequency f_{VCLK} , is fed back through a programmable prescale divider and a programmable modulo divider. The prescaler divides the VCO clock by a power-of-two factor, P, and the modulo divider reduces the VCO clock by a factor, N. The divider's output is the VCO feedback clock, CGMVDV, running at a frequency $f_{VDV} = f_{VCLK}/(N \times 2^P)$. (See [7.3.2.4 Programming the PLL](#) for more information.)

The phase detector then compares the VCO feedback clock, CGMVDV, with the final reference clock, CGMRDV. A correction pulse is generated based on the phase difference between the two signals. The

loop filter then slightly alters the DC voltage on the external capacitor connected to CGMXFC based on the width and direction of the correction pulse. The filter can make fast or slow corrections depending on its mode, described in [7.3.2.2 Acquisition and Tracking Modes](#). The value of the external capacitor and the reference frequency determines the speed of the corrections and the stability of the PLL.

The lock detector compares the frequencies of the VCO feedback clock, CGMVDV, and the final reference clock, CGMRDV. Therefore, the speed of the lock detector is directly proportional to the final reference frequency f_{RDV} . The circuit determines the mode of the PLL and the lock condition based on this comparison.

7.3.2.2 Acquisition and Tracking Modes

The PLL filter is manually or automatically configurable into one of two operating modes:

- Acquisition mode — In acquisition mode, the filter can make large frequency corrections to the VCO. This mode is used at PLL start-up or when the PLL has suffered a severe noise hit and the VCO frequency is far off the desired frequency. When in acquisition mode, the \overline{ACQ} bit is clear in the PLL bandwidth control register. (See [7.5.2 PLL Bandwidth Control Register](#).)
- Tracking mode — In tracking mode, the filter makes only small corrections to the frequency of the VCO. PLL jitter is much lower in tracking mode, but the response to noise is also slower. The PLL enters tracking mode when the VCO frequency is nearly correct, such as when the PLL is selected as the base clock source. (See [7.3.3 Base Clock Selector Circuit](#).) The PLL is in tracking mode automatically when not in acquisition mode or when the \overline{ACQ} bit is set.

7.3.2.3 Manual and Automatic PLL Bandwidth Modes

The PLL can change the bandwidth or operational mode of the loop filter manually or automatically.

In automatic bandwidth control mode (AUTO = 1), the lock detector automatically switches between acquisition and tracking modes. Automatic bandwidth control mode also is used to determine when the VCO clock, CGMVCLK, is safe to use as the source for the base clock, CGMOUT. (See [7.5.2 PLL Bandwidth Control Register](#).) If PLL interrupts are enabled, the software can wait for a PLL interrupt request and then check the LOCK bit. If interrupts are disabled, software can poll the LOCK bit continuously (during PLL startup, usually) or at periodic intervals. In either case, when the LOCK bit is set, the VCO clock is safe to use as the source for the base clock. (See [7.3.3 Base Clock Selector Circuit](#).) If the VCO is selected as the source for the base clock and the LOCK bit is clear, the PLL has suffered a severe noise hit and the software must take appropriate action, depending on the application. (See [7.6 Interrupts](#) for information and precautions on using interrupts.) These conditions apply when the PLL is in automatic bandwidth control mode:

- The \overline{ACQ} bit (see [7.5.2 PLL Bandwidth Control Register](#)) is a read-only indicator of the mode of the filter. (See [7.3.2.2 Acquisition and Tracking Modes](#).)
- The \overline{ACQ} bit is set when the VCO frequency is within a certain tolerance, Δ_{TRK} , and is cleared when the VCO frequency is out of a certain tolerance, Δ_{UNT} . (See [7.9 Acquisition/Lock Time Specifications](#) for more information.)
- The LOCK bit is a read-only indicator of the locked state of the PLL.
- The LOCK bit is set when the VCO frequency is within a certain tolerance, Δ_{LOCK} , and is cleared when the VCO frequency is out of a certain tolerance, Δ_{UNL} . (See [7.9 Acquisition/Lock Time Specifications](#) for more information.)
- CPU interrupts can occur if enabled (PLLIE = 1) when the PLL's lock condition changes, toggling the LOCK bit. (See [7.5.1 PLL Control Register](#).)

The PLL also may operate in manual mode (AUTO = 0). Manual mode is used by systems that do not require an indicator of the lock condition for proper operation. Such systems typically operate well below f_{BUSMAX} and require fast startup. These conditions apply when in manual mode:

- $\overline{\text{ACQ}}$ is a writable control bit that controls the mode of the filter. Before turning on the PLL in manual mode, the $\overline{\text{ACQ}}$ bit must be clear.
- Before entering tracking mode ($\overline{\text{ACQ}} = 1$), software must wait a given time, t_{ACQ} (see [7.9 Acquisition/Lock Time Specifications](#)), after turning on the PLL by setting PLLON in the PLL control register (PCTL).
- Software must wait a given time, t_{AL} , after entering tracking mode before selecting the PLL as the clock source to CGMOUT (BCS = 1).
- The LOCK bit is disabled.
- CPU interrupts from the CGMB are disabled.

7.3.2.4 Programming the PLL

This procedure shows how to program the PLL.

NOTE

The round function in the following equations means that the real number should be rounded to the nearest integer number.

1. Choose the desired bus frequency, f_{BUSDES} .
2. Calculate the desired VCO frequency (four times the desired bus frequency).

$$f_{\text{VCLKDES}} = 4 \times f_{\text{BUSDES}}$$

3. Choose a practical PLL reference frequency, f_{RCLK} .
4. Select the prescaler power-of-two multiplier, P.

$$P = \text{integer} \left[\frac{\log \left(\frac{2^{\text{P}_{\text{MAX}}} \times f_{\text{VCLKDES}}}{f_{\text{VCLKMAX}}} \right)}{\log(2)} \right] + 1$$

5. Select the reference divider based on the resolution desired. For maximum resolution, use the formula below. However, higher degrees of resolution slow down the final reference frequency, which may cause acquisition time to increase and may affect the value of the external capacitor. For more information, see [7.9 Acquisition/Lock Time Specifications](#).

$$R = \text{round} \left[R_{\text{MAX}} \times \left\{ \left(\frac{f_{\text{VCLKDES}}}{2^{\text{P}} \times f_{\text{RCLK}}} \right) - \text{integer} \left(\frac{f_{\text{VCLKDES}}}{2^{\text{P}} \times f_{\text{RCLK}}} \right) \right\} \right]$$

Clock Generator Module (CGMB)

Select a VCO frequency multiplier, N.

$$N = \text{round}\left(\frac{R \times f_{VCLKDES}}{2^P \times f_{RCLK}}\right)$$

6. For fastest acquisition time, reduce N/R until R is the smallest value possible. For example, if N = 6 and R = 4, N reduces to 3 and R reduces to 2.
7. Calculate and verify the adequacy of the VCO and bus frequencies f_{VCLK} and f_{BUS} .

$$f_{VCLK} = N \times f_{RCLK}$$

$$f_{VCLK} = (2^P \times N/R) \times f_{RCLK}$$

$$f_{BUS} = (f_{VCLK})/4$$

8. Select the VCO's power-of-two range multiplier, E. Higher values of E should be used at higher frequencies.

$$E = \text{integer}\left[\frac{\log\left(\frac{2^{EMAX} \times f_{VCLK}}{f_{VRSMAX}}\right)}{\log(2)}\right] + 1$$

Select a VCO linear range multiplier, L, where $f_{NOM} = 38.4$ KHz

$$L = \text{round}\left(\frac{f_{VCLK}}{2^E \times f_{NOM}}\right)$$

9. Calculate and verify the adequacy of the VCO programmed center-of-range frequency f_{VRS} .
 $f_{VRS} = (L \times 2^E) f_{NOM}$
10. Verify the choice of P, R, N, E, and L by comparing f_{VCLK} to f_{VRS} and $f_{VCLKDES}$. For proper operation, f_{VCLK} must be within the application's tolerance of $f_{VCLKDES}$, and f_{VRS} must be as close as possible to f_{VCLK} .

NOTE

Exceeding the recommended maximum bus frequency or VCO frequency can crash the MCU.

11. Program the PLL registers accordingly:
 - a. In the PRE bits of the PLL control register, program the binary equivalent of P.
 - b. In the VPR bits of the PLL control register, program the binary equivalent of E.
 - c. In the PLL multiplier select register low and the PLL multiplier select register high, program the binary equivalent of N.
 - d. In the PLL VCO range select register, program the binary coded equivalent of L.
 - e. In the PLL reference divider select register, program the binary coded equivalent of R.

Refer to [Table 7-1](#) for a numeric example with numbers in hexadecimal notation.

Table 7-1. Numeric Example of PLL Register Programming

| Bus frequency | E | P | N | L | R |
|---------------|---|---|----|----|---|
| 307,200 Hz | 1 | 1 | 10 | 10 | 1 |
| 614,400 Hz | 1 | 1 | 20 | 20 | 1 |
| 652,800 Hz | 2 | 2 | 11 | 11 | 1 |
| 691,200 Hz | 2 | 2 | 12 | 12 | 1 |
| 729,600 Hz | 2 | 2 | 13 | 13 | 1 |
| 768,000 Hz | 2 | 2 | 14 | 14 | 1 |
| 806,400 Hz | 2 | 2 | 15 | 15 | 1 |
| 998,400 Hz | 2 | 2 | 1a | 1a | 1 |

NOTE

The numeric examples given in [Table 7-1](#) assume a crystal frequency of 38.4 kHz.

7.3.2.5 Special Programming Exceptions

The programming method described in [7.3.2.4 Programming the PLL](#) does not account for three possible exceptions. A value of 0 for R, N, or L is meaningless when used in the equations given. To account for these exceptions:

- A 0 value for R or N is interpreted exactly the same as a value of one at the minimum frequency and the VCO range power-of-two bits.
- A 0 value for L disables the PLL and prevents its selection as the source for the base clock. (See [7.3.3 Base Clock Selector Circuit](#).)

7.3.3 Base Clock Selector Circuit

This circuit is used to select either the crystal clock, CGMXCLK, or the VCO clock, CGMVCLK, as the source of the base clock, CGMOUT. The two input clocks go through a transition control circuit that waits up to three CGMXCLK cycles and three CGMVCLK cycles to change from one clock source to the other. During this time, CGMOUT is held in stasis. The output of the transition control circuit is then divided by two to correct the duty cycle. Therefore, the bus clock frequency, which is one-half of the base clock frequency, is one-fourth the frequency of the selected clock (CGMXCLK or CGMVCLK).

The BCS bit in the PLL control register (PCTL) selects which clock drives CGMOUT. The VCO clock cannot be selected as the base clock source if the PLL is not turned on. The PLL cannot be turned off if the VCO clock is selected. The PLL cannot be turned on or off simultaneously with the selection or deselection of the VCO clock. The VCO clock also cannot be selected as the base clock source if the factor L is programmed to a 0. This value would set up a condition inconsistent with the operation of the PLL, so that the PLL would be disabled and the crystal clock would be forced as the source of the base clock.

7.3.4 CGMB External Connections

In its typical configuration, the CGMB requires seven external components. Five of these are for the crystal oscillator and two are for the PLL.

The crystal oscillator normally is connected in a Pierce oscillator configuration, as shown in Figure 7-2. Figure 7-2 shows only the logical representation of the internal components and may not represent actual circuitry. The oscillator configuration uses five components:

- Crystal, X_1
- Fixed capacitor, C_1
- Tuning capacitor, C_2 (can also be a fixed capacitor)
- Feedback resistor, R_B
- Series resistor, R_S (optional)

The series resistor (R_S) is included in the diagram to follow strict Pierce oscillator guidelines and may not be required for all ranges of operation, especially with high frequency crystals. Refer to the crystal manufacturer's data for more information.

Figure 7-2 also shows the external components for the PLL:

- Bypass capacitor, C_{BYP}
- Filter capacitor, C_F

Routing should be done with great care to minimize signal cross talk and noise.

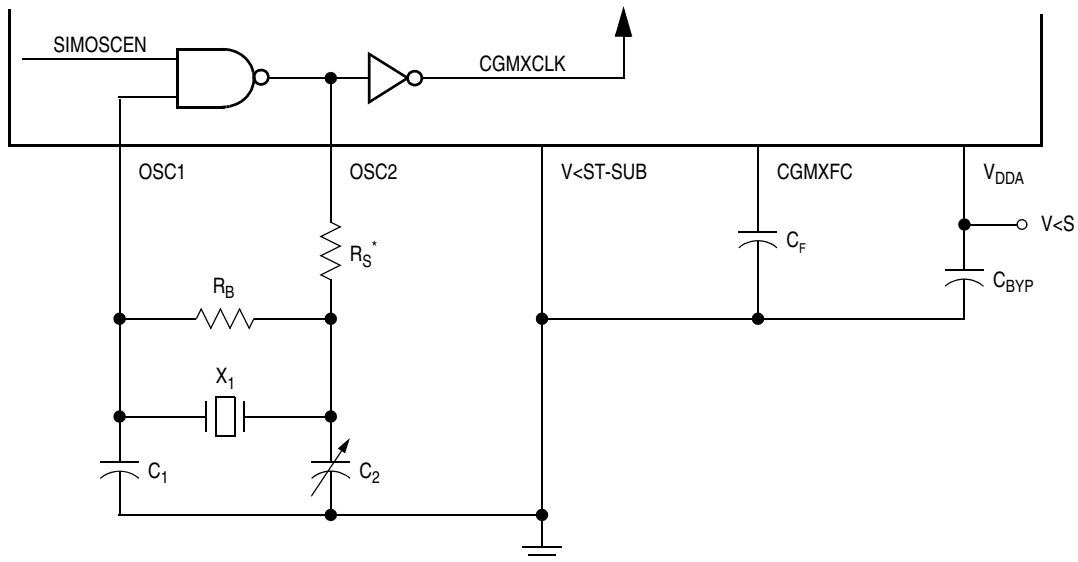

* R_S can be 0 (shorted) when used with higher-frequency crystals. Refer to manufacturer's data.

Figure 7-2. CGMB External Connections

7.4 I/O Signals

This section describes the CGMB input/output (I/O) signals.

7.4.1 Crystal Amplifier Input Pin (OSC1)

The OSC1 pin is an input to the crystal oscillator amplifier.

7.4.2 Crystal Amplifier Output Pin (OSC2)

The OSC2 pin is the output of the crystal oscillator inverting amplifier.

7.4.3 External Filter Capacitor Pin (CGMXFC)

The CGMXFC pin is required by the loop filter to filter out phase corrections. A small external capacitor is connected to this pin.

NOTE

To prevent noise problems, C_F should be placed as close to the CGMXFC pin as possible, with minimum routing distances and no routing of other signals across the C_F connection.

7.4.4 PLL Analog Power Pin (V_{DDA})

V_{DDA} is a power pin used by the analog portions of the PLL. Connect the V_{DDA} pin to the same voltage potential as the V_{DD} pin.

NOTE

Route V_{DDA} carefully for maximum noise immunity and place bypass capacitors as close as possible to the package.

7.4.5 PLL Analog Ground Pin (V_{SSA})

V_{SSA} is a ground pin used by the analog portions of the PLL. Connect the V_{SSA} pin to the same voltage potential as the V_{SS} pin.

NOTE

Route V_{SSA} carefully for maximum noise immunity and place bypass capacitors as close as possible to the package.

7.4.6 Oscillator Enable Signal (SIMOSCEN)

The SIMOSCEN signal comes from the system integration module (SIM) and enables the oscillator and PLL.

7.4.7 Crystal Output Frequency Signal (CGMXCLK)

CGMXCLK is the crystal oscillator output signal. It runs at the full speed of the crystal (f_{XCLK}) and comes directly from the crystal oscillator circuit. [Figure 7-2](#) shows only the logical relation of CGMXCLK to OSC1 and OSC2 and may not represent the actual circuitry. The duty cycle of CGMXCLK is unknown and may depend on the crystal and other external factors. Also, the frequency and amplitude of CGMXCLK can be unstable at startup.

7.4.8 CGMB Base Clock Output (CGMOUT)

CGMOUT is the clock output of the CGMB. This signal goes to the SIM, which generates the MCU clocks. CGMOUT is a 50% duty cycle clock running at twice the bus frequency. CGMOUT is software programmable to be either the oscillator output, CGMXCLK, divided by two or the VCO clock, CGMVCLK, divided by two.

7.4.9 CGMB CPU Interrupt (CGMINT)

CGMINT is the interrupt signal generated by the PLL lock detector.

7.5 CGMB Registers

These registers control and monitor operation of the CGMB:

- PLL control register (see [7.5.1 PLL Control Register](#))
- PLL bandwidth control register (see [7.5.2 PLL Bandwidth Control Register](#))
- PLL multiplier select register high (see [7.5.3 PLL Multiplier Select Register High](#))
- PLL multiplier select register low (see [7.5.4 PLL Multiplier Select Register Low](#))
- PLL VCO range select register (see [7.5.5 PLL VCO Range Select Register](#))
- PLL reference divider select register (see [7.5.6 PLL Reference Divider Select Register](#))

Figure 7-3 provides a summary of the CGMB registers.

| Addr. | Name | Bit 7 | 6 | 5 | 4 | 3 | 2 | 1 | Bit 0 | |
|--------|--|--------|-------|------|-------|------|-------|-------|-------|------|
| \$0007 | PLL Control Register (PCTL) | Read: | PLLIE | PLLF | PLLON | BCS | PRE1 | PRE0 | VPR1 | VPR0 |
| | | Write: | | | | | | | | |
| | | Reset: | 0 | 0 | 1 | 0 | 1 | 1 | 1 | 1 |
| \$0008 | PLL Bandwidth Control Register (PBWC) | Read: | AUTO | LOCK | ACQ | 0 | 0 | 0 | 0 | R |
| | | Write: | | | | | | | | |
| | | Reset: | 0 | 0 | 0 | 0 | 0 | 0 | 0 | 0 |
| \$0009 | PLL Multiplier Select Register High (PMSH) | Read: | 0 | 0 | 0 | 0 | MUL11 | MUL10 | MUL9 | MUL8 |
| | | Write: | | | | | | | | |
| | | Reset: | 0 | 0 | 0 | 0 | 0 | 0 | 0 | 0 |
| \$000A | PLL Multiplier Select Register Low (PMSL) | Read: | MUL7 | MUL6 | MUL5 | MUL4 | MUL3 | MUL2 | MUL1 | MUL0 |
| | | Write: | | | | | | | | |
| | | Reset: | 0 | 1 | 0 | 0 | 0 | 0 | 0 | 0 |
| \$000B | PLL VCO Range Select Register (PVRS) | Read: | VRS7 | VRS6 | VRS5 | VRS4 | VRS3 | VRS2 | VRS1 | VRS0 |
| | | Write: | | | | | | | | |
| | | Reset: | 0 | 1 | 0 | 0 | 0 | 0 | 0 | 0 |
| \$000C | PLL Reference Divider Select Register (PRDS) | Read: | 0 | 0 | 0 | 0 | RDS3 | RDS2 | RDS1 | RDS0 |
| | | Write: | | | | | | | | |
| | | Reset: | 0 | 0 | 0 | 0 | 0 | 0 | 0 | 1 |

= Unimplemented
 = Reserved

Figure 7-3. CGMB I/O Register Summary

7.5.1 PLL Control Register

The PLL control register (PCTL) contains the interrupt enable and flag bits, the on/off switch, the base clock selector bit, the prescaler bits, and the VCO power of two range selector bits.

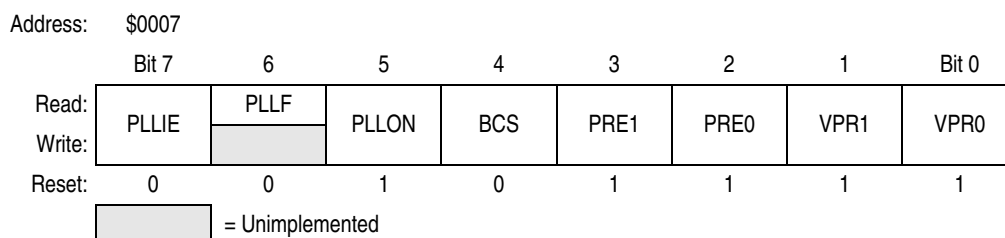

Figure 7-4. PLL Control Register (PCTL)

PLLIE — PLL interrupt enable bit

This read/write bit enables the PLL to generate an interrupt request when the LOCK bit toggles, setting the PLL flag, PLLIF. When the AUTO bit in the PLL bandwidth control register (PBWC) is clear, PLLIE cannot be written and reads as logic 0. Reset clears the PLLIE bit.

- 1 = PLL interrupts enabled
- 0 = PLL interrupts disabled

PLLIF — PLL interrupt flag bit

This read-only bit is set whenever the LOCK bit toggles. PLLIF generates an interrupt request if the PLLIE bit also is set. PLLIF always reads as logic 0 when the AUTO bit in the PLL bandwidth control register (PBWC) is clear. Clear the PLLIF bit by reading the PLL control register. Reset clears the PLLIF bit.

- 1 = Change in lock condition
- 0 = No change in lock condition

NOTE

Do not inadvertently clear the PLLIF bit. Any read or read-modify-write operation on the PLL control register clears the PLLIF bit.

PLLON — PLL on bit

This read/write bit activates the PLL and enables the VCO clock, CGMVCLK. PLLON cannot be cleared if the VCO clock is driving the base clock, CGMOUT (BCS = 1). (See [7.3.3 Base Clock Selector Circuit](#).) Reset sets this bit so that the loop can stabilize as the MCU is powering up.

- 1 = PLL on
- 0 = PLL off

BCS — Base clock select bit

This read/write bit selects either the crystal oscillator output, CGMXCLK, or the VCO clock, CGMVCLK, as the source of the CGM output, CGMOUT. CGMOUT frequency is one-half the frequency of the selected clock. BCS cannot be set while the PLLON bit is clear. After toggling BCS, it may take up to three CGMXCLK and three CGMVCLK cycles to complete the transition from one source clock to the other. During the transition, CGMOUT is held in stasis. (See [7.3.3 Base Clock Selector Circuit](#).) Reset clears the BCS bit.

- 1 = CGMVCLK divided by two drives CGMOUT
- 0 = CGMXCLK divided by two drives CGMOUT

NOTE

PLLON and BCS have built-in protection that prevents the base clock selector circuit from selecting the VCO clock as the source of the base clock if the PLL is off. Therefore, PLLON cannot be cleared when BCS is set, and BCS cannot be set when PLLON is clear. If the PLL is off (PLLON = 0), selecting CGMVCLK requires two writes to the PLL control register. (See [7.3.3 Base Clock Selector Circuit](#).)

PRE1 and PRE0 — Prescaler program bits

These read/write bits control a prescaler that selects the prescaler power-of-two multiplier, P. (See [7.3.2.1 PLL Circuits](#) and [7.3.2.4 Programming the PLL](#).) PRE1 and PRE0 cannot be written when the PLLON bit is set. Reset clears these bits.

Table 7-2. PRE1 and PRE0 Programming

| PRE1 and PRE0 | P | Prescaler multiplier |
|---------------|---|----------------------|
| 00 | 0 | 1 |
| 01 | 1 | 2 |
| 10 | 2 | 4 |
| 11 | 3 | 8 |

VPR1 and VPR0 — VCO power-of-two range select bits

These read/write bits control the VCO’s hardware power-of-two range multiplier, E, that, in conjunction with L (See [7.3.2.1 PLL Circuits](#), [7.3.2.4 Programming the PLL](#), and [7.5.5 PLL VCO Range Select Register](#).) controls the hardware center-of-range frequency, f_{VRS} . VPR1 and VPR0 cannot be written when the PLLON bit is set. Reset clears these bits.

Table 7-3. VPR1 and VPR0 Programming

| VPR1 and VPR0 | E | VCO power-of-two range multiplier |
|---------------|---|-----------------------------------|
| 00 | 0 | 1 |
| 01 | 1 | 2 |
| 10 | 2 | 4 |
| 11 | 3 | 8 |

7.5.2 PLL Bandwidth Control Register

The PLL bandwidth control register (PBWC):

- Selects automatic or manual (software-controlled) bandwidth control mode
- Indicates when the PLL is locked
- In automatic bandwidth control mode, indicates when the PLL is in acquisition or tracking mode
- In manual operation, forces the PLL into acquisition or tracking mode

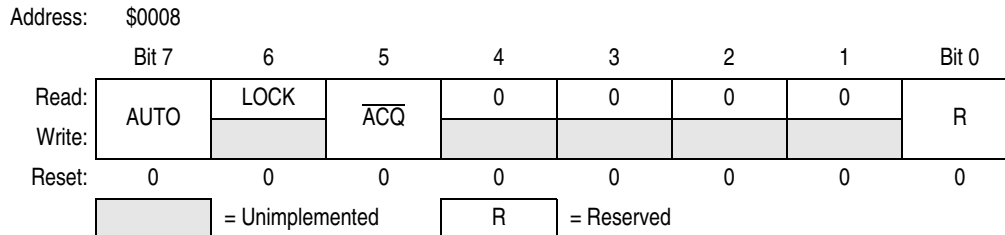

Figure 7-5. PLL Bandwidth Control Register (PBWC)

AUTO — Automatic bandwidth control bit

This read/write bit selects automatic or manual bandwidth control. When initializing the PLL for manual operation (AUTO = 0), clear the \overline{ACQ} bit before turning on the PLL. Reset clears the AUTO bit.

- 1 = Automatic bandwidth control
- 0 = Manual bandwidth control

LOCK — Lock indicator bit

When the AUTO bit is set, LOCK is a read-only bit that becomes set when the VCO clock, CGMVCLK, is locked (running at the programmed frequency). When the AUTO bit is clear, LOCK reads as logic 0 and has no meaning.

NOTE

The write function of this bit is reserved for test, so this bit must always be written a 0.

Reset clears the LOCK bit.

- 1 = VCO frequency correct or locked
- 0 = VCO frequency incorrect or unlocked

\overline{ACQ} — Acquisition mode bit

When the AUTO bit is set, \overline{ACQ} is a read-only bit that indicates whether the PLL is in acquisition mode or tracking mode. When the AUTO bit is clear, \overline{ACQ} is a read/write bit that controls whether the PLL is in acquisition or tracking mode.

In automatic bandwidth control mode (AUTO = 1), the last-written value from manual operation is stored in a temporary location and is recovered when manual operation resumes. Reset clears this bit, enabling acquisition mode.

- 1 = Tracking mode
- 0 = Acquisition mode

7.5.3 PLL Multiplier Select Register High

The PLL multiplier select register high (PMSH) contains the programming information for the high byte of the modulo feedback divider.

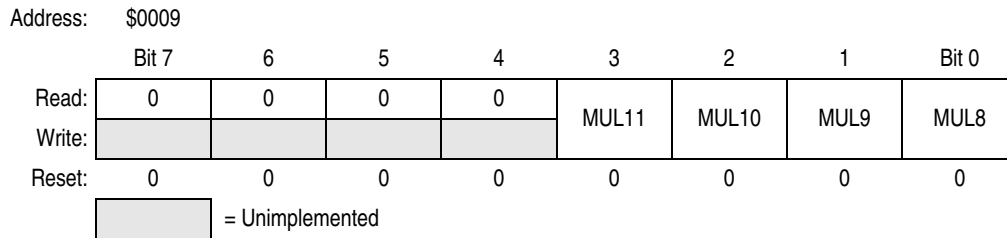

Figure 7-6. PLL Multiplier Select Register High (PMSH)

MUL11–MUL8 — Multiplier select bits

These read/write bits control the high byte of the modulo feedback divider that selects the VCO frequency multiplier N. (See [7.3.2.1 PLL Circuits](#) and [7.3.2.4 Programming the PLL](#).) A value of \$0000 in the multiplier select registers configures the modulo feedback divider the same as a value of \$0001. Reset initializes the registers to \$0040, for a default multiply value of 64.

NOTE

The multiplier select bits have built-in protection such that they cannot be written when the PLL is on (PLLON = 1).

7.5.4 PLL Multiplier Select Register Low

The PLL multiplier select register (PMSL) low contains the programming information for the low byte of the modulo feedback divider.

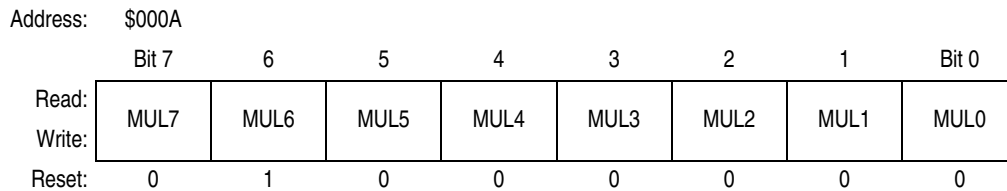

Figure 7-7. PLL Multiplier Select Register Low (PMSL)

MUL7–MUL0 — Multiplier select bits

These read/write bits control the low byte of the modulo feedback divider that selects the VCO frequency multiplier, N. (See [7.3.2.1 PLL Circuits](#) and [7.3.2.4 Programming the PLL](#).) MUL7–MUL0 cannot be written when the PLLON bit in the PCTL is set. A value of \$0000 in the multiplier select registers configures the modulo feedback divider the same as a value of \$0001. Reset initializes the register to \$40, for a default multiply value of 64.

NOTE

The multiplier select bits have built-in protection such that they cannot be written when the PLL is on (PLLON = 1).

7.5.5 PLL VCO Range Select Register

The PLL VCO range select register (PVRS) contains the programming information required for the hardware configuration of the VCO.

| | | | | | | | | |
|----------|--------|------|------|------|------|------|------|-------|
| Address: | \$000B | | | | | | | |
| | Bit 7 | 6 | 5 | 4 | 3 | 2 | 1 | Bit 0 |
| Read: | VRS7 | VRS6 | VRS5 | VRS4 | VRS3 | VRS2 | VRS1 | VRS0 |
| Write: | | | | | | | | |
| Reset: | 0 | 1 | 0 | 0 | 0 | 0 | 0 | 0 |

Figure 7-8. PLL VCO Range Select Register (PVRS)

VRS7–VRS0 — VCO range select bits

These read/write bits control the hardware center-of-range linear multiplier L which, in conjunction with E (see [7.3.2.1 PLL Circuits](#), [7.3.2.4 Programming the PLL](#), and [7.5.1 PLL Control Register](#)), controls the hardware center-of-range frequency, f_{VRS} . VRS7–VRS0 cannot be written when the PLLON bit in the PCTL is set (see [7.3.2.5 Special Programming Exceptions](#)).

A value of \$00 in the VCO range select register disables the PLL and clears the BCS bit in the PLL control register. (See [7.3.3 Base Clock Selector Circuit](#) and [7.3.2.5 Special Programming Exceptions](#).) Reset initializes the register to \$40 for a default range multiply value of 64.

NOTE

The VCO range select bits have built-in protection such that they cannot be written when the PLL is on (PLLON = 1) and such that the VCO clock cannot be selected as the source of the base clock (BCS = 1) if the VCO range select bits are all clear.

The PLL VCO range select register must be programmed correctly. Incorrect programming may result in failure of the PLL to achieve lock.

7.5.6 PLL Reference Divider Select Register

The PLL reference divider select register (PRDS) contains the programming information for the modulo reference divider.

| | | | | | | | | |
|----------|--------|---|---|---|------|------|------|-------|
| Address: | \$000C | | | | | | | |
| | Bit 7 | 6 | 5 | 4 | 3 | 2 | 1 | Bit 0 |
| Read: | 0 | 0 | 0 | 0 | RDS3 | RDS2 | RDS1 | RDS0 |
| Write: | | | | | | | | |
| Reset: | 0 | 0 | 0 | 0 | 0 | 0 | 0 | 0 |

 = Unimplemented

Figure 7-9. PLL Reference Divider Select Register (PRDS)

RDS3–RDS0 — Reference divider select bits

These read/write bits control the modulo reference divider that selects the reference division factor R. (See [7.3.2.1 PLL Circuits](#) and [7.3.2.4 Programming the PLL](#).) RDS7–RDS0 cannot be written when the PLLON bit in the PCTL is set.

Clock Generator Module (CGMB)

A value of \$00 in the reference divider select register configures the reference divider the same as a value of \$01. (See [7.3.2.5 Special Programming Exceptions](#).) Reset initializes the register to \$01, for a default divide value of 1.

NOTE

The reference divider select bits have built-in protection such that they cannot be written when the PLL is on (PLLON = 1).

7.6 Interrupts

When the AUTO bit is set in the PLL bandwidth control register (PBWC), the PLL can generate a CPU interrupt request every time the LOCK bit changes state. The PLLIE bit in the PLL control register (PCTL) enables CPU interrupts from the PLL. PLLF, the interrupt flag in the PCTL, becomes set whether interrupts are enabled or not. When the AUTO bit is clear, CPU interrupts from the PLL are disabled and PLLF reads as logic 0.

Software should read the LOCK bit after a PLL interrupt request to see if the request was due to an entry into lock or an exit from lock. When the PLL enters lock, the VCO clock, CGMVCLK, divided by two can be selected as the CGMOUT source by setting BCS in the PCTL. When the PLL exits lock, the VCO clock frequency is corrupt, and appropriate precautions should be taken. If the application is not frequency-sensitive, interrupts should be disabled to prevent PLL interrupt service routines from impeding software performance or from exceeding stack limitations.

NOTE

Software can select the CGMVCLK divided by two as the CGMOUT source even if the PLL is not locked (LOCK = 0). Therefore, software should make sure the PLL is locked before setting the BCS bit.

7.7 Wait Mode

The WAIT instruction put the MCU in low power-consumption standby mode.

The WAIT instruction does not affect the CGMB. Before entering wait mode, software can disengage and turn off the PLL by clearing the BCS and PLLON bits in the PLL control register (PCTL). Less power-sensitive applications can disengage the PLL without turning it off. Applications that require the PLL to wake the MCU from wait mode also can deselect the PLL output without turning off the PLL.

7.8 CGMB During Break Interrupts

The system integration module (SIM) controls whether status bits in other modules can be cleared during the break state. The BCFE bit in the SIM break flag control register (SBFCR) enables software to clear status bits during the break state. (See [6.7.3 SIM Break Flag Control Register](#).)

To allow software to clear status bits during a break interrupt, write a logic 1 to the BCFE bit. If a status bit is cleared during the break state, it remains cleared when the MCU exits the break state.

To protect the PLLF bit during the break state, write a logic 0 to the BCFE bit. With BCFE at logic 0 (its default state), software can read and write the PLL control register during the break state without affecting the PLLF bit.

7.9 Acquisition/Lock Time Specifications

The acquisition and lock times of the PLL are, in many applications, the most critical PLL design parameters. Proper design and use of the PLL ensures the highest stability and lowest acquisition/lock times.

7.9.1 Acquisition/Lock Time Definitions

Typical control systems refer to the acquisition time or lock time as the reaction time, within specified tolerances, of the system to a step input. In a PLL, the step input occurs when the PLL is turned on or when it suffers a noise hit. The tolerance is usually specified as a percent of the step input or when the output settles to the desired value plus or minus a percent of the frequency change. Therefore, the reaction time is constant in this definition, regardless of the size of the step input.

For example, consider a system with a 5% acquisition time tolerance.

- If a command instructs the system to change from 0 Hz to 1 MHz, the acquisition time is the time taken for the frequency to reach 1 MHz \pm 50 kHz. Fifty kHz = 5% of the 1-MHz step input.
- Or, if the system is operating at 1 MHz and suffers a -100 kHz noise hit, the acquisition time is the time taken to return from 900 kHz to 1 MHz \pm 5 kHz. Five kHz = 5% of the 100-kHz step input.

Other systems refer to acquisition and lock times as the time the system takes to reduce the error between the actual output and the desired output to within specified tolerances. Therefore, the acquisition or lock time varies according to the original error in the output. Minor errors may not even be registered. Typical PLL applications prefer to use this definition because the system requires the output frequency to be within a certain tolerance of the desired frequency regardless of the size of the initial error.

The discrepancy in these definitions makes it difficult to specify an acquisition or lock time for a typical PLL. Therefore, the definitions for acquisition and lock times for this module are as follows:

- Acquisition time, t_{ACQ} , is the time the PLL takes to reduce the error between the actual output frequency and the desired output frequency to less than the tracking mode entry tolerance, Δ_{TRK} . Acquisition time is based on an initial frequency error, $(f_{DES} - f_{ORIG})/f_{DES}$, of not more than $\pm 100\%$. In automatic bandwidth control mode (see [7.3.2.3 Manual and Automatic PLL Bandwidth Modes](#)), acquisition time expires when the ACQ bit becomes set in the PLL bandwidth control register (PBWC).
- Lock time, t_{LOCK} , is the time the PLL takes to reduce the error between the actual output frequency and the desired output frequency to less than the lock mode entry tolerance, Δ_{LOCK} . Lock time is based on an initial frequency error, $(f_{DES} - f_{ORIG})/f_{DES}$, of not more than $\pm 100\%$. In automatic bandwidth control mode, lock time expires when the $LOCK$ bit becomes set in the PLL bandwidth control register (PBWC). (See [7.3.2.3 Manual and Automatic PLL Bandwidth Modes](#).)

Obviously, the acquisition and lock times can vary according to how large the frequency error is and may be shorter or longer in many cases.

7.9.2 Parametric Influences on Reaction Time

Acquisition and lock times are designed to be as short as possible while still providing the highest possible stability. These reaction times are not constant, however. Many factors directly and indirectly affect the acquisition time.

The most critical parameter which affects the reaction times of the PLL is the reference frequency, f_{RDV} . This frequency is the input to the phase detector and controls how often the PLL makes corrections. For stability, the corrections must be small compared to the desired frequency, so several corrections are

required to reduce the frequency error. Therefore, the slower the reference the longer it takes to make these corrections. This parameter is also under user control via the choice of crystal frequency f_{XCLK} and the R value programmed in the reference divider. (See [7.3.2.1 PLL Circuits](#), [7.3.2.4 Programming the PLL](#), and [7.5.6 PLL Reference Divider Select Register](#)).

Another critical parameter is the external filter capacitor. The PLL modifies the voltage on the VCO by adding or subtracting charge from this capacitor. Therefore, the rate at which the voltage changes for a given frequency error (thus change in charge) is proportional to the capacitor size. The size of the capacitor also is related to the stability of the PLL. If the capacitor is too small, the PLL cannot make small enough adjustments to the voltage and the system cannot lock. If the capacitor is too large, the PLL may not be able to adjust the voltage in a reasonable time. (See [7.9.3 Choosing a Filter Capacitor](#).)

Also important is the operating voltage potential applied to V_{DDA} . The power supply potential alters the characteristics of the PLL. A fixed value is best. Variable supplies, such as batteries, are acceptable if they vary within a known range at very slow speeds. Noise on the power supply is not acceptable, because it causes small frequency errors which continually change the acquisition time of the PLL.

Temperature and processing also can affect acquisition time because the electrical characteristics of the PLL change. The part operates as specified as long as these influences stay within the specified limits. External factors, however, can cause drastic changes in the operation of the PLL. These factors include noise injected into the PLL through the filter capacitor, filter capacitor leakage, stray impedances on the circuit board, and even humidity or circuit board contamination.

7.9.3 Choosing a Filter Capacitor

As described in [7.9.2 Parametric Influences on Reaction Time](#), the external filter capacitor, C_F , is critical to the stability and reaction time of the PLL. The PLL also is dependent on reference frequency and supply voltage. The value of the capacitor must, therefore, be chosen with supply potential and reference frequency in mind. For proper operation, the external filter capacitor must be chosen according to this equation:

$$C_F = C_{FACT} \left(\frac{V_{DDA}}{f_{RDV}} \right)$$

For acceptable values of C_{FACT} , see [7.9 Acquisition/Lock Time Specifications](#). For the value of V_{DDA} , choose the voltage potential at which the MCU is operating. If the power supply is variable, choose a value near the middle of the range of possible supply values.

This equation does not always yield a commonly available capacitor size, so round to the nearest available size. If the value is between two different sizes, choose the higher value for better stability. Choosing the lower size may seem attractive for acquisition time improvement, but the PLL may become unstable. Also, always choose a capacitor with a tight tolerance ($\pm 20\%$ or better) and low dissipation.

7.9.4 Reaction Time Calculation

The actual acquisition and lock times can be calculated using the equations here. These equations yield nominal values under the following conditions:

- Correct selection of filter capacitor, C_F (see [7.9.3 Choosing a Filter Capacitor](#))
- Room temperature operation
- Negligible external leakage on CGMXFC
- Negligible noise

The K factor in the equations is derived from internal PLL parameters. K_{ACQ} is the K factor when the PLL is configured in acquisition mode, and K_{TRK} is the K factor when the PLL is configured in tracking mode. (See [7.3.2.2 Acquisition and Tracking Modes](#).)

$$t_{ACQ} = \left(\frac{V_{DDA}}{f_{RDV}} \right) \left(\frac{8}{K_{ACQ}} \right)$$

$$t_{AL} = \left(\frac{V_{DDA}}{f_{RDV}} \right) \left(\frac{4}{K_{TRK}} \right)$$

$$t_{LOCK} = t_{ACQ} + t_{AL}$$

NOTE

The inverse proportionality between the lock time and the reference frequency.

In automatic bandwidth control mode, the acquisition and lock times are quantized into units based on the reference frequency. (See [7.3.2.3 Manual and Automatic PLL Bandwidth Modes](#).) A certain number of clock cycles, n_{ACQ} , is required to ascertain that the PLL is within the tracking mode entry tolerance, Δ_{TRK} , before exiting acquisition mode. A certain number of clock cycles, n_{TRK} , is required to ascertain that the PLL is within the lock mode entry tolerance, Δ_{LOCK} . Therefore, the acquisition time, t_{ACQ} , is an integer multiple of n_{ACQ}/f_{RDV} , and the acquisition to lock time, t_{AL} , is an integer multiple of n_{TRK}/f_{RDV} . Also, since the average frequency over the entire measurement period must be within the specified tolerance, the total time usually is longer than t_{LOCK} as calculated above.

In manual mode, it is usually necessary to wait considerably longer than t_{LOCK} before selecting the PLL clock (see [7.3.3 Base Clock Selector Circuit](#)), because the factors described in [7.9.2 Parametric Influences on Reaction Time](#) may slow the lock time considerably.



Chapter 8

Functional Controller Module (FCM)

8.1 Introduction

The FCM provides timekeeping functions and the software computer operating properly (COP) mechanism.

8.2 Features

Features of the FCM include:

- Real-time clock with seconds, minutes, and hours counters
- Software chronograph counter
- Watchdog timer
- Alarm clock with interrupts

8.3 Functional Description

The functional controller module (FCM) includes several of the functional controller circuits traditionally designed into custom MCUs for paging applications. This module is specifically targeted for use with the HC08 CPU.

The circuits included are:

- Real-time clock (RTC) interrupts with chronograph register
- Watchdog timer, also called the computer operating properly (COP) timer
- Time base circuit which supports 32.000-kHz and 38.400-kHz crystal oscillators

In addition to these two crystal options, a provision to use a crystal with a frequency two times these frequencies has been created. This was designed specifically for use with a 76.8-kHz crystal oscillator.

This module provides nine registers for software control. The clock source of the RTC interrupts and status registers are synchronized to the bus timing to ensure synchronous register access.

8.4 Module Description

The functional controller module is an HC08-compatible module designed for use in paging applications. It connects to the HC08 internal bus and communicates to the HC08 CPU by way of the address bus, data bus, and control signals. The crystal oscillator signal (CGMXCLK) enters the module and connects to the timebase circuit. The timebase creates clock signals which feed the real-time clock.

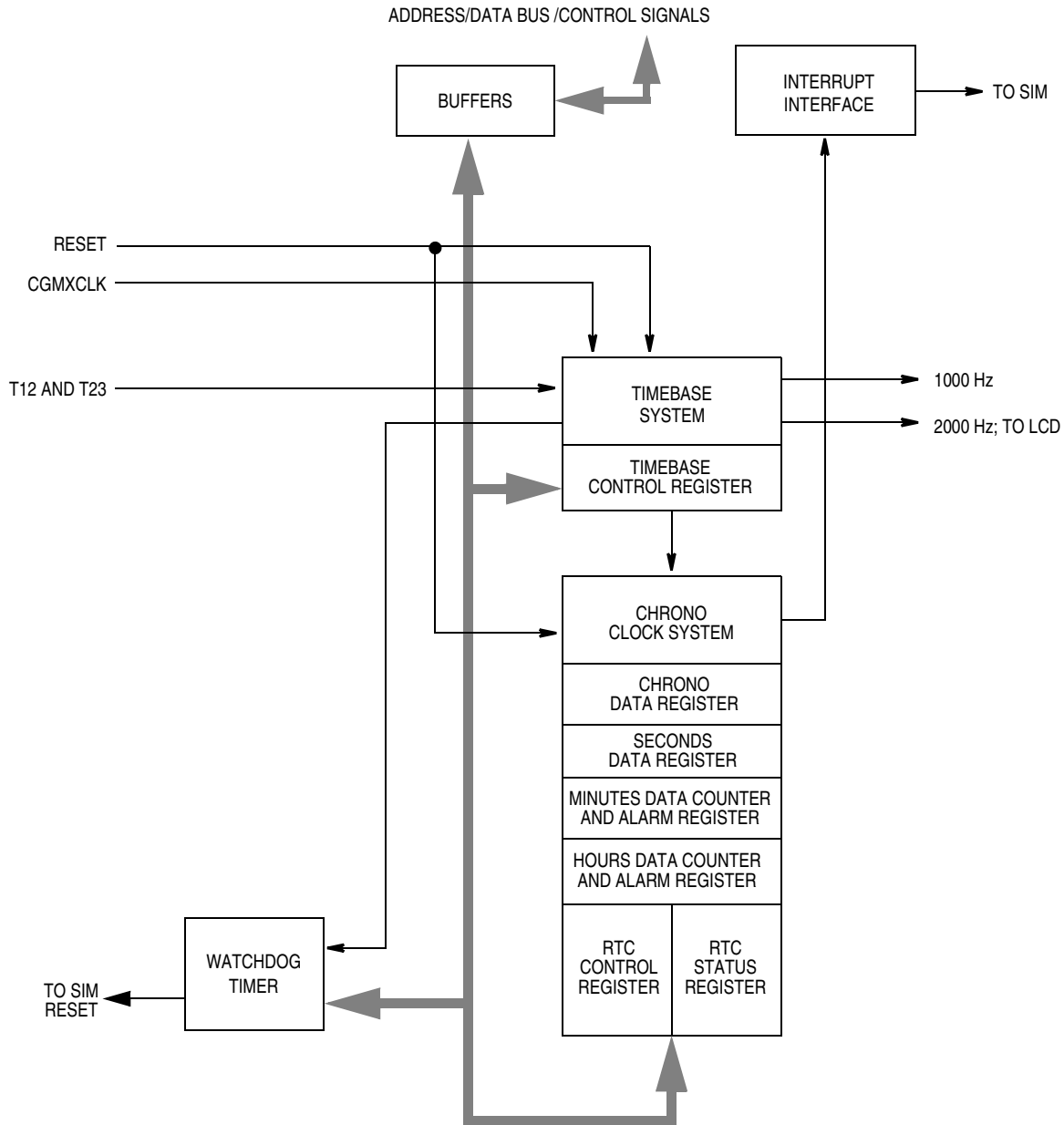

Figure 8-1. Functional Controller Block Diagram

8.4.1 Timebase Submodule

The timebase submodule is designed to create timing signals equivalent to any binary division of the crystal oscillator frequency. Clock signals created at frequencies of 1 Hz, 2 Hz, and 4 Hz are fed to the real-time clock (RTC) submodule. When a frequency of 4 Hz is selected, the frequency will vary from 5 Hz to 3.3 Hz with an average of 4 Hz. The timebase circuit also generates a 100-Hz clock signal which is fed to the RTC to produce a software chronograph function. In addition, two signals (1 kHz and 2 kHz) are created for use by other MCU modules. Software selectable options are available to support the use of a 32.000-kHz or 38.400-kHz crystal oscillator. The default option is for 38.400 kHz.

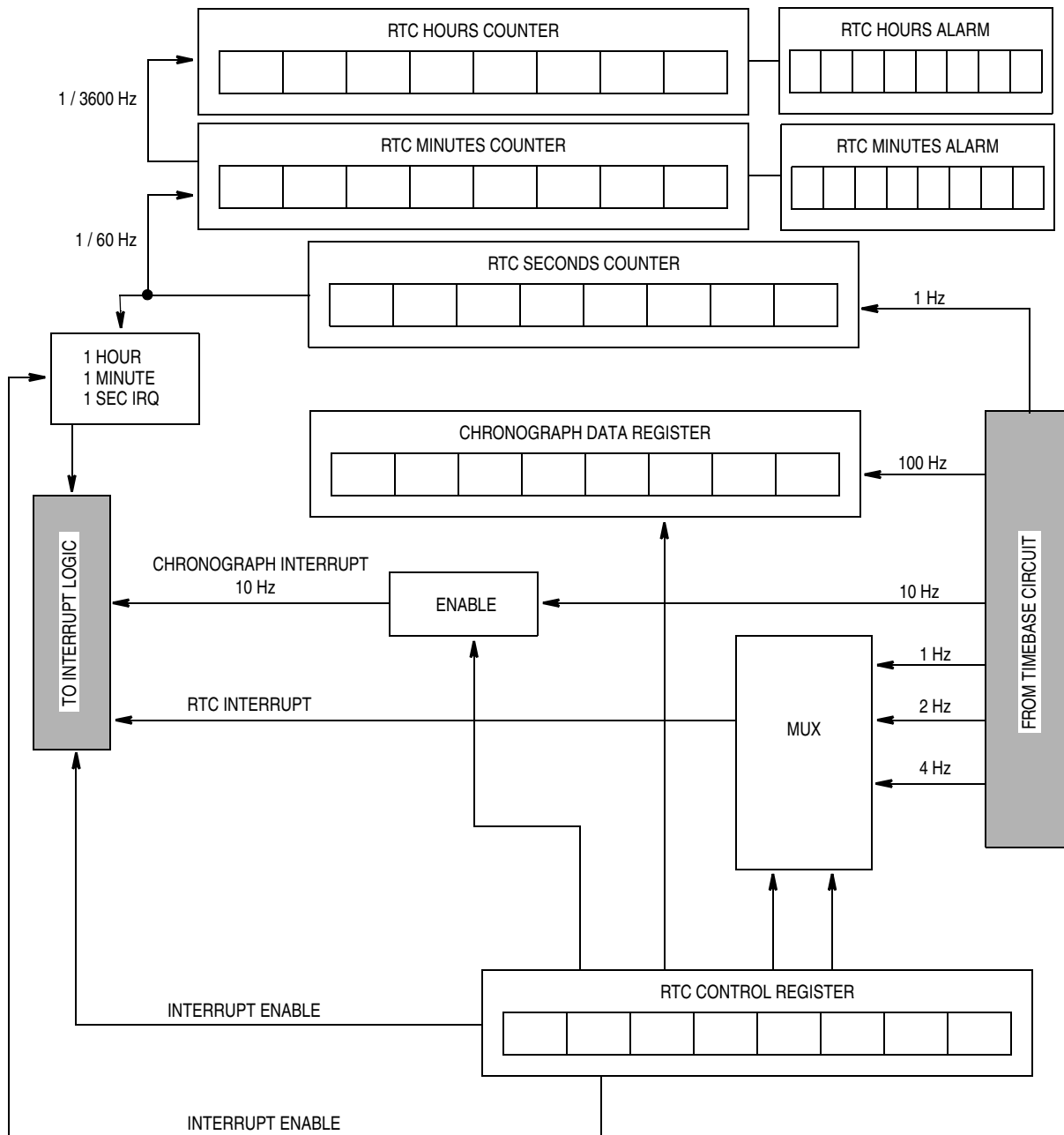

Figure 8-2. Real-Time Clock System Block Diagram

8.4.2 Real-Time Clock Submodule

The RTC module consists of the RTC control register, the chronograph data register, the hours, minutes, and seconds registers for timekeeping, and the hours and minutes alarm registers. The real-time clock (RTC) system will provide a periodic interrupt to the CPU of 1 hour, 1 minute, 1 second, 1 Hz, 2 Hz, or 4 Hz for software timekeeping functions and an interrupt with 10 Hz resolution which can be used to generate chronometer functions in software. When a periodic interrupt of 4 Hz is selected, the periodic interrupt will vary from 5 Hz to 3.3 Hz with an average of 4 Hz. The chronograph data register can be

Functional Controller Module (FCM)

cleared using the CHRC bit in the timebase control register. See [Figure 8-4](#). The timebase counter can also be cleared by setting the TBCLR in the timebase control register. See [Figure 8-4](#).

NOTE

This section assumes that a 32.000-kHz oscillator or a 38.400-kHz oscillator is used, according to the software option selected. These crystals will generate precise interrupts. Crystals of a frequency two times these frequencies can also be used to generate accurate RTC clock control. Any other oscillator frequency will not provide accurate 100 Hz and 1 Hz counters.

8.4.3 COP Watchdog Timer Submodule

The computer operating properly (COP) or watchdog timer subsystem is a software selectable feature which will generate a system reset if not serviced within the specified watchdog timeout period. The watchdog timer counter chain is derived from an output of the timebase circuit. This input signal is divided to give the watchdog timer reset rate selected by the first write to the COP select bits in the timebase control register.

A watchdog timer reset is performed by writing any data to address \$FFFF. This will reset the counter chain and begin the timeout countdown again. The watchdog timer counter chain is also cleared when the MCU is in reset.

The value of the two watchdog timer rate select bits in the timebase control register (TBCR) determines the watchdog timer timeout rate. These bits can be written only on the first write to this register after a reset. If these bits are never written to, the watchdog timer reset rate will be set at 1 second when a 32-kHz crystal is used (see [Table 8-1](#)).

NOTE

Although these bits default to 0, the user should write to these bits to prevent subsequent writes from changing the timeout rate. A bit set/clear for any bit in this register is executed as a read-modify-write of this register. If used as the first write to this register, further writes to CRS[1:0] would not be valid, and the default value would still be set.

The CPU clock halts during wait mode, but the oscillator and the watchdog timer system are still active. The software should exit wait mode to service the watchdog timer system before the COP timeout period.

If the STOP instruction is executed on an MCU with stop mode enabled, the watchdog timer circuit will be disabled. The COP timer is enabled when the MCU comes out of reset.

NOTE

The MC68HC(9)08LK60 does not allow stop mode operation.

8.5 Interrupts

The RTC submodule is capable of generating interrupts. Three different interrupts can be generated by the clock sections of the real-time clock submodule:

- 1 minute, 1 Hz, 2 Hz, or 4 Hz
- Alarm
- Chronograph, 10 Hz

These interrupts are enabled by setting the corresponding bit in the RTC control register.

NOTE

When an interrupt of 4 Hz is selected, the periodic interrupt will vary from 5 Hz to 3.3 Hz with an average of 4 Hz.

8.6 I/O Signals

The functional controller module is connected to the HC08 bus and has no external pins.

8.7 Interrupt Signals (FCM, CPU, and IRQ)

The interrupt signals provide the capability for sending an interrupt request to the CPU. The FCM has one interrupt line coming out of the FCM to the system integration module and is an OR function of the enabled interrupt sources (chronograph alarm, seconds, minutes, hours, or periodic interrupt).

8.8 Functional Controller Registers

Figure 8-3 provides a summary of the functional controller registers.

| Addr. | Name | Bit 7 | 6 | 5 | 4 | 3 | 2 | 1 | Bit 0 | |
|--------|-----------------------------------|--------|-------|-------|-------|-------|-------|-------|-------|-------|
| \$0035 | Timebase Control Register (TBCR) | Read: | 0 | CHRC | CRS1 | CRS0 | R | TB2X | TB0 | |
| | | Write: | RTCE | | | | | | | TBCLR |
| | | Reset: | 0 | 0 | 0 | 0 | 0 | 0 | 0 | 0 |
| \$0036 | RTC Control Register (RTCCR) | Read: | HRIE | MINIE | SECIE | CHRIE | CHRCE | ALIEN | PRQ1 | PRQ0 |
| | | Write: | | | | | | | | |
| | | Reset: | 0 | 0 | 0 | 0 | 0 | 0 | 0 | 0 |
| \$0037 | RTC Status Register (RTCSR) | Read: | 0 | 0 | PRQF | HORF | MINF | SECF | AFLG | CHRF |
| | | Write: | | | | | | | | |
| | | Reset: | 0 | 0 | 0 | 0 | 0 | 0 | 0 | 0 |
| \$0038 | Chronograph Data Register (CHRDR) | Read: | BIT 7 | BIT 6 | BIT 5 | BIT 4 | BIT 3 | BIT 2 | BIT 1 | BIT 0 |
| | | Write: | | | | | | | | |
| | | Reset: | 0 | 0 | 0 | 0 | 0 | 0 | 0 | 0 |
| \$0039 | RTC Seconds Register (SECR) | Read: | 0 | 0 | SEC5 | SEC4 | SEC3 | SEC2 | SEC1 | SEC0 |
| | | Write: | | | | | | | | |
| | | Reset: | 0 | 0 | 0 | 0 | 0 | 0 | 0 | 0 |
| \$003A | RTC Minutes Register (MINR) | Read: | 0 | 0 | MIN5 | MIN4 | MIN3 | MIN2 | MIN1 | MIN0 |
| | | Write: | | | | | | | | |
| | | Reset: | 0 | 0 | 0 | 0 | 0 | 0 | 0 | 0 |
| \$003B | RTC Hours Register (HORR) | Read: | 0 | 0 | 0 | HOR4 | HOR3 | HOR2 | HOR1 | HOR0 |
| | | Write: | | | | | | | | |
| | | Reset: | 0 | 0 | 0 | 0 | 0 | 0 | 0 | 0 |
| \$003C | Alarm Minutes Register (ALRMR) | Read: | 0 | 0 | AM5 | AM4 | AM3 | AM2 | AM1 | AM0 |
| | | Write: | | | | | | | | |
| | | Reset: | 0 | 0 | 0 | 0 | 0 | 0 | 0 | 0 |
| \$003D | Alarm Hours Register (ALRHR) | Read: | 0 | 0 | 0 | AH4 | AH3 | AH2 | AH1 | AH0 |
| | | Write: | | | | | | | | |
| | | Reset: | 0 | 0 | 0 | 0 | 0 | 0 | 0 | 0 |

 = Unimplemented R = Reserved

Figure 8-3. Summary of the Functional Controller Registers

8.8.1 Timebase Control Register

This timebase control register (TBCR) is a read/write register containing control bits for the timebase outputs which feed other circuits.

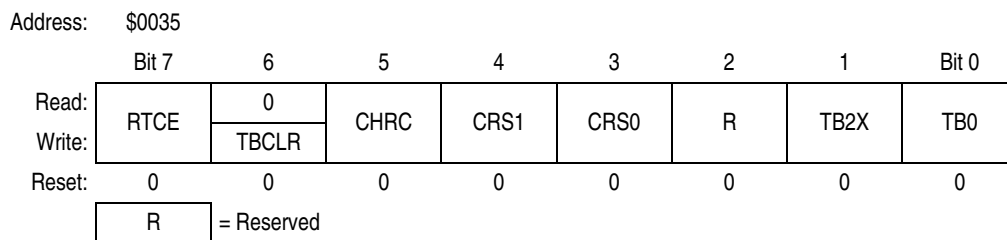

Figure 8-4. Timebase Control Register (TBCR)

RTCE — Real-time clock enable bit

When set to 1, the real-time clock counters are enabled. This bit is cleared by reset.

NOTE

Enabling this bit will affect the clock that increments the seconds counter. It is recommended that this write be performed at the start of the reset sequence, to limit any timing discrepancies resulting from the timebase clocks.

TBCLR — Timebase clear bit

When set to 1, the timebase counter chain is cleared. This bit will automatically clear after the timebase clear function has occurred. This bit will always read a 0 and is cleared by reset.

NOTE

Clearing the timebase by setting TBCLR will affect all clocks derived from the timebase, including the real-time clock inputs and the LCD.

CHRC — Chronograph clear bit

This bit clears all bits in the chronograph data register and holds it at that state until this bit is cleared by software.

- 0 = Allows chronograph data register to begin counting
- 1 = Clears chronograph data register and holds value at \$00

CRS1 and CRS0 — COP rate select bit

The value of these two bits determines the watchdog timer (WDT) timeout rate. These bits can be written only on the first write to this register after reset. If these bits are never written to, the WDT reset rate will be set at one second.

NOTE

Although these bits default to 0, the user should write to these bits to prevent subsequent writes from changing the timeout rate.

A bit set/clear for any bit in this register is executed as a read-modify-write of this register. If used as the first write to this register, further writes to CRS[1:0] would not be valid, and the default value would be set.

Table 8-1. Watchdog Timer Timeout Rates

| CRS1 and CRS0 | Minimum COP rate @32.000 kHz | Minimum COP rate @38.400 kHz |
|---------------|---------------------------------|---------------------------------|
| 00 | 1 sec | 0.85 sec |
| 01 | 2 sec | 1.7 sec |
| 10 | 4 sec | 3.4 sec |
| 11 | 8 sec | 6.8 sec |

NOTE

Watchdog refresh shortens the minimum COP rates, given in [Table 8-1](#), by 0.0067 seconds for 38.4-K crystal and by 0.008 seconds for 32-K crystal.

TB2X — Timebase times 2 bit

When set to 1, the timebase counter chain is divided by two. This bit was added specifically to accommodate the use of the 76.8-kHz crystal oscillator.

This bit is cleared by reset.

NOTE

This bit can only be set ONCE following a reset and can be written only on the first write to this register after reset.

TBO — Timebase crystal option bit

This bit is used to configure the timebase clocks for the crystal oscillator used to clock the MCU. Refer to [Table 8-2](#) for the crystal options selected by these bits. This bit is cleared by reset.

Table 8-2. Timebase Crystal Options

| TBO | Crystal (Hz) |
|-----|--------------|
| 0 | 38,400 |
| 1 | 32,000 |

NOTE

The timebase will start up as if the 38.4-kHz option had been chosen until this bit is written to. This bit can only be set ONCE following a reset and can be written only on the first write to this register after reset. It is recommended that this write be performed at the start of the reset sequence, to limit any timing discrepancies resulting from the timebase clocks.

8.8.2 RTC Control Register

The RTC control register (RTCCR) is a read/write register containing eight control bits. These bits enable the chronograph function and control interrupts associated with the RTC status register flags.

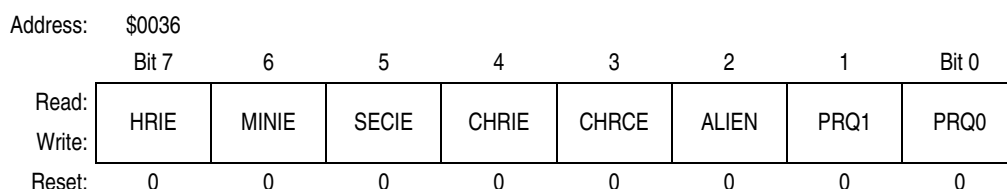

Figure 8-5. RTC Control Register (RTCCR)

HRIE — Hours interrupt enable bit

This bit controls whether an interrupt is generated when the HORF bit is set in the RTC status register.

0 = Interrupt disabled

1 = Interrupt enabled

MINIE — Minutes interrupt enable bit

This bit controls whether an interrupt is generated when the MINF bit is set in the RTC status register.

0 = Interrupt disabled

1 = Interrupt enabled

SECIE — Seconds interrupt enable bit

This bit controls whether an interrupt is generated when the SECF bit is set in the RTC status register.

0 = Interrupt disabled

1 = Interrupt enabled

CHRIE — Chronograph interrupt enable bit

This bit controls whether an interrupt is generated when the CHRF bit is set in the RTC status register.

0 = Interrupt disabled

1 = Interrupt enabled

CHRCE — Chronograph clock enable bit

This bit controls the 100-Hz clock signal to the RTC chronograph register. This bit is cleared by reset.

0 = 100-Hz signal disabled, RTC chronograph off

1 = 100 Hz signal enabled

ALIEN — Alarm interrupt enable bit

This bit controls whether an interrupt is generated when the AFLG bit is set in the RTC status register.

0 = Interrupt disabled

1 = Interrupt enabled

PRQ1 and PRQ0 — RTC periodic interrupt selection bits

These bits control which frequency pulse should be sent from the RTC to generate a periodic interrupt request. This request is sent to the CPU. These bits select periodic interrupts of 1 Hz, 2 Hz, or 4 Hz as shown in [Table 8-3](#).

Table 8-3. PRQ1 and PRQ0 RTC Interrupt Periods

| PRQ1 and PRQ0 | RTC interrupt period |
|---------------|----------------------------|
| 00 | RTC interrupt is disabled. |
| 01 | RTC interrupt is 1 Hz. |
| 10 | RTC interrupt is 2 Hz. |
| 11 | RTC interrupt is 4 Hz. |

NOTE

When a periodic interrupt of 4 Hz is selected, the periodic interrupt will vary from 5 Hz to 3.3 Hz with an average of 4 Hz.

8.8.3 RTC Status Register

The RTC status register (RTCSR) is a read-only register containing six status bits. See [Figure 8-6](#).

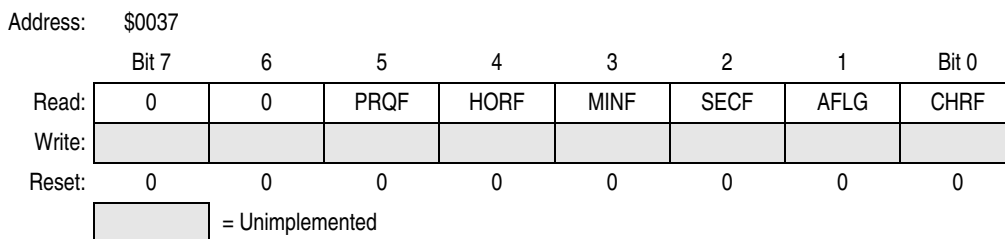
Figure 8-6. RTC Status Register (RTCSR)

PRQF — Periodic interrupt flag

PRQF is a status bit indicating that the 1 Hz, 2 Hz, or 4 Hz interval has elapsed. When a periodic interrupt of 4 Hz is selected, the periodic interrupt will vary from 5 Hz to 3.3 Hz with an average of 4 Hz. Reset clears PRQF. A CPU interrupt will be generated if the PRQ1 and PRQ0 bits are set in the RTCCR.

0 = Flag cleared by a read of the RTC Status Register with the PRQF flag set, followed by a read of the RTC control register. Both read operations need not be consecutive.

1 = Flag automatically set at 1 Hz, 2 Hz, or 4 Hz intervals. When a periodic interrupt of 4 Hz is selected, the periodic interrupt will vary from 5 Hz to 3.3 Hz with an average of 4 Hz.

HORF — Hours flag

HORF is a status bit indicating that the hours counter has rolled over. Reset clears HORF. A CPU interrupt will be generated if the HRIE bit is set in the RTCCR.

0 = Flag cleared by a read of the RTC status register with the HORF flag set, followed by a read of the hours register. Both read operations need not be consecutive.

1 = Flag automatically set at 1-hour intervals

MINF — Minutes flag

MINF is a status bit indicating that the minutes counter 1 has rolled over. Reset clears MINF. A CPU interrupt will be generated if the MINIE bit is set in the RTCCR.

0 = Flag cleared by a read of the RTC status register with the MINF flag set, followed by a read of the minutes register. Both read operations need not be consecutive.

1 = Flag automatically set at 1-minute intervals

SECF — Seconds flag

SECF is a status bit indicating that the seconds counter 1-Hz interval has elapsed. Reset clears SECF. A CPU interrupt will be generated if the SECIE bit is set in the RTCCR.

- 0 = Flag cleared by a read of the RTC status register with the SECF flag set, followed by a read of the seconds register. Both read operations need not be consecutive.
- 1 = Flag automatically set at 1-Hz intervals

AFLG — Alarm flag

AFLG is a status bit indicating that the hours counter matches the alarm hours register and the minutes counter matches the alarm minutes register. Reset clears AFLG. A CPU interrupt will be generated if the ALIEN bit is set in the RTCCR.

- 0 = Flag cleared by a read of the RTC status register with the AFLG flag set, followed by a read of the alarm minutes register. Both read operations need not be consecutive.
- 1 = Flag automatically set at scheduled alarm time

CHRF — Chronograph flag

CHRF is a status bit indicating that the chronograph 10-Hz interval has elapsed. A CPU interrupt request will be generated if CHRIF is set. Reset clears CHRF.

- 0 = Flag cleared by a read of the RTC status register with the CHRF flag set, followed by a read of the chronograph data register. Both read operations need not be consecutive.
- 1 = Flag automatically set at 10-Hz intervals

8.8.4 Chronograph Data Register

The chronograph data register (CHRDR) is a read-only register containing the value of a counter which is driven by the 100-Hz output of the timebase circuit. This counter has a resolution of 1 ÷ 100 seconds, or 10 ms. The counter rolls over to 0 after reaching \$FF. Appropriate software must be written to convert the value read from this register in real time.

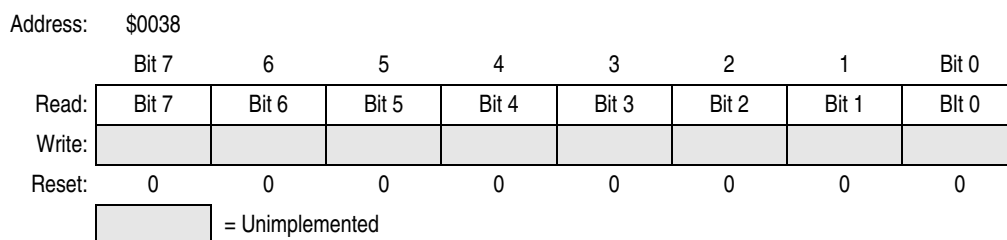

Figure 8-7. Chronograph Data Register (CHRDR)

8.8.5 Seconds Data Register

The seconds data register (SECR) is a read-write register containing the value of a counter which is driven by the 1-Hz output of the timebase circuit. Only six bits are used in this register, which rolls over to 0 when the count reaches 59. Reset clears these bits. Once the correct value is set in this register, the register will contain the current time in seconds.

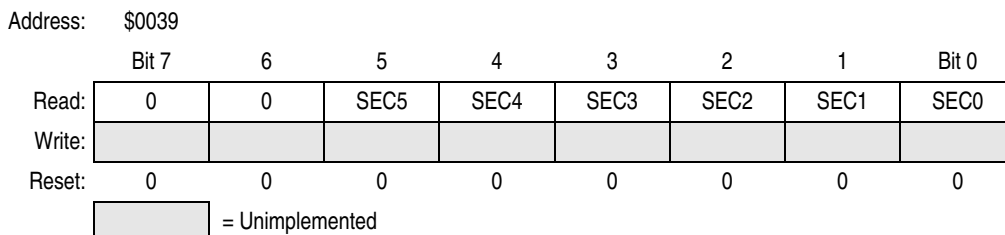

Figure 8-8. Seconds Data Register (SECR)

8.8.6 Minutes Data Register

The minutes data register (MINR) is a read-write register containing the value of a counter which is driven by the output of the seconds register. Only six bits are used in this register, which rolls over to 0 when the count reaches 59. Reset clears these bits. Once the correct time is written to this register, it will contain the current time in minutes.

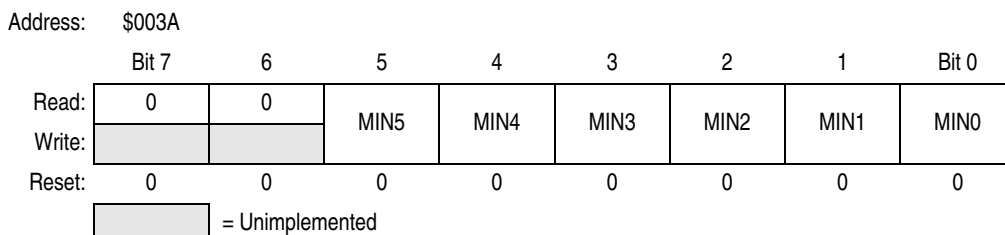

Figure 8-9. Minutes Data Register (MINR)

8.8.7 Hours Data Register

The hours data register (HORR) is a read-write register containing the value of a counter which is driven by the output of the minutes register. Only five bits are used in this register, which rolls over to 0 when the count reaches 23. Reset clears these bits. Once the current time is written to this register, it will contain the current time in the 24 hours clock.

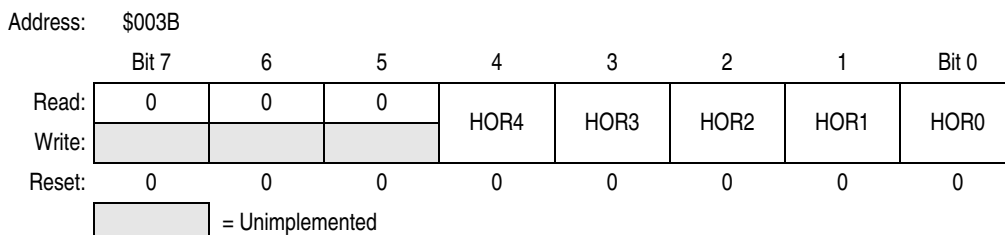

Figure 8-10. Hours Data Register (HORR)

8.8.8 Alarm Minutes Register

The alarm minutes register (ALRMR) is a read-write register containing the value for alarm generation used to match with the minutes data register. Only six bits are used in this register. Reset clears these bits.

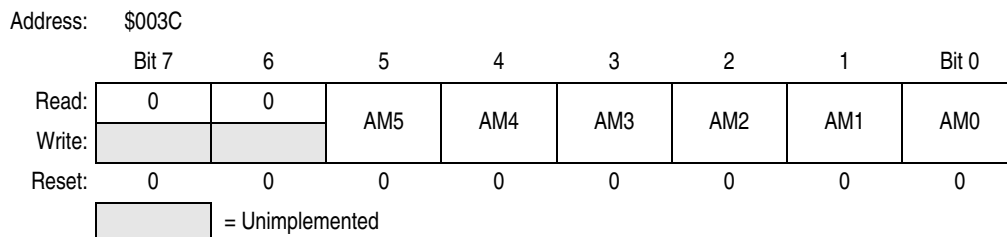

Figure 8-11. Alarm Minutes Register (ALRMR)

8.8.9 Alarm Hours Register

The alarm hours register (ALRHR) is a read-write register containing the value for alarm generation used to match with the hours data register. Only five bits are used in this register. Reset clears these bits.

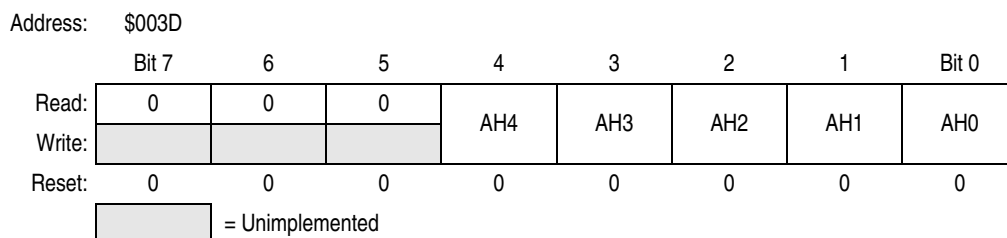

Figure 8-12. Alarm Hours Register (ALRHR)

Chapter 9

Break Module

9.1 Introduction

This section describes the break module. The break module can generate a break interrupt that stops normal program flow at a defined address to enter a background program.

9.2 Features

Features of the break module include:

- Accessible input/output (I/O) registers during the break interrupt
- CPU-generated break interrupts
- Software-generated break interrupts
- Computer operating properly (COP) disabling during break interrupts

9.3 Functional Description

When the internal address bus matches the value written in the break address registers, the break module issues a breakpoint signal ($\overline{\text{BKPT}}$) to the system integration module (SIM). The SIM then causes the CPU to load the instruction register with a software interrupt instruction (SWI) after completion of the current CPU instruction. The program counter vectors to \$FFFC and \$FFFD (\$FEFC and \$FEFD in monitor mode).

These events can cause a break interrupt to occur:

- A CPU-generated address (the address in the program counter) matches the contents of the break address registers.
- Software writes a logic 1 to the BRKA bit in the break status and control register.

When a CPU-generated address matches the contents of the break address registers, the break interrupt begins after the CPU completes its current instruction. A return-from-interrupt instruction (RTI) in the break routine ends the break interrupt and returns the MCU to normal operation. [Figure 9-1](#) shows the structure of the break module.

9.3.1 Flag Protection During Break Interrupts

The SIM controls whether or not module status bits can be cleared during the break state. The BCFE bit in the SIM break flag control register (SBFCR) enables software to clear status bits during the break state. For further information, see [6.7.3 SIM Break Flag Control Register](#) and the **Break Interrupts** subsection for each module.

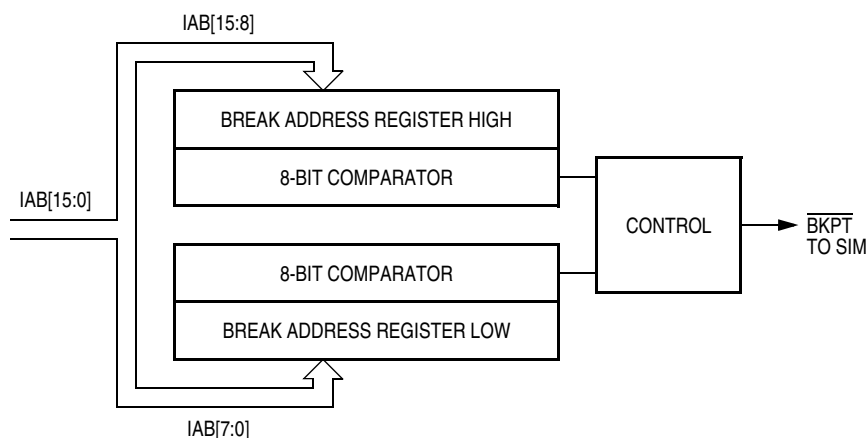

Figure 9-1. Break Module Block Diagram

| Addr. | Name | | Bit 7 | 6 | 5 | 4 | 3 | 2 | 1 | Bit 0 |
|--------|--|--------|--------|--------|--------|--------|--------|--------|-------|-------|
| \$FE0C | Break Address Register High (BRKH) | Read: | Bit 15 | Bit 14 | Bit 13 | Bit 12 | Bit 11 | Bit 10 | Bit 9 | Bit 8 |
| | | Write: | | | | | | | | |
| | | Reset: | 0 | 0 | 0 | 0 | 0 | 0 | 0 | 0 |
| \$FE0D | Break Address Register Low (BRKL) | Read: | Bit 7 | Bit 6 | Bit 5 | Bit 4 | Bit 3 | Bit 2 | Bit 1 | Bit 0 |
| | | Write: | | | | | | | | |
| | | Reset: | 0 | 0 | 0 | 0 | 0 | 0 | 0 | 0 |
| \$FE0E | Break Status/Control Register (BRKSCR) | Read: | BRKE | BRKA | 0 | 0 | 0 | 0 | 0 | 0 |
| | | Write: | | | | | | | | |
| | | Reset: | 0 | 0 | 0 | 0 | 0 | 0 | 0 | 0 |

= Unimplemented

Figure 9-2. Break I/O Register Summary

9.3.2 CPU During Break Interrupts

The CPU starts a break interrupt by:

- Loading the instruction register with the SWI instruction
- Loading the program counter with \$FFFC–\$FFFD; \$FEFC–\$FEFD in monitor mode

The break interrupt begins after completion of the CPU instruction in progress. If the break address register match occurs on the last cycle of a CPU instruction, the break interrupt begins immediately.

9.3.3 TIM During Break Interrupts

A break interrupt stops the timer counter.

9.3.4 COP During Break Interrupts

The COP is disabled during a break interrupt when $V_{DD} + V_{HI}$ is present on the \overline{RST} pin.

9.4 Break Module Registers

Three registers control and monitor operation of the break module:

- Break status and control register (BRKSCR)
- Break address register high (BRKH)
- Break address register low (BRKL)

9.4.1 Break Status and Control Register

The break status and control register (BRKSCR) contains break module enable and status bits.

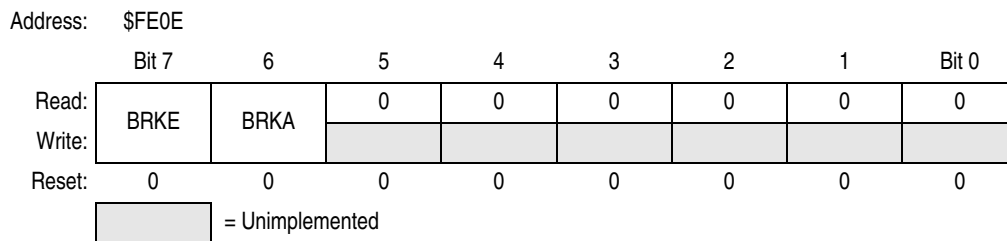

Figure 9-3. Break Status and Control Register (BRKSCR)

BRKE — Break enable bit

This read/write bit enables breaks on break address register matches. Clear BRKE by writing a logic 0 to bit 7. Reset clears the BRKE bit.

- 1 = Breaks enabled on 16-bit address match
- 0 = Breaks disabled on 16-bit address match

BRKA — Break active bit

This read/write status and control bit is set when a break address match occurs. Writing a logic 1 to BRKA generates a break interrupt. Clear BRKA by writing a logic 0 to it before exiting the break routine. Reset clears the BRKA bit.

- 1 = Break address match
- 0 = No break address match

9.4.2 Break Address Registers

The break address registers (BRKH and BRKL) contain the high and low bytes of the desired breakpoint address. Reset clears the break address registers.

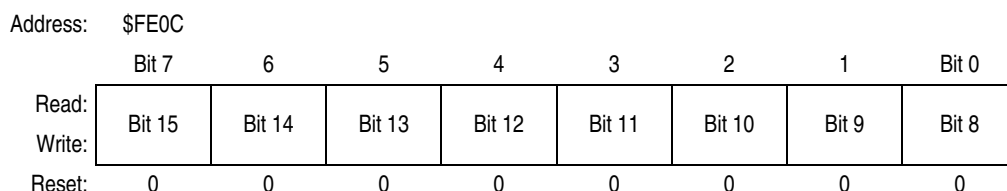

Figure 9-4. Break Address Register High (BRKH)

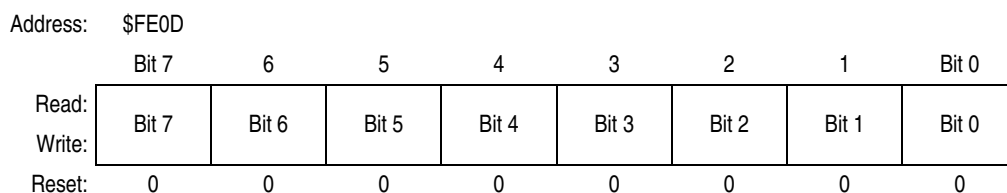

Figure 9-5. Break Address Register Low (BRKL)

9.5 Low-Power Modes

The WAIT and STOP instructions put the MCU in low power-consumption standby modes.

9.5.1 Wait Mode

If enabled, the break module is active in wait mode. In the break routine, the user can subtract one from the return address on the stack if SBSW is set. Clear the SBSW bit by writing logic 0 to it.

9.5.2 Stop Mode

A break interrupt causes exit from stop mode and sets the SBSW bit in the SIM break status register. See [6.7 SIM Registers](#).

NOTE

The MC68HC(9)08LK60 does not allow stop mode operation.

Chapter 10

Power-On Reset Module (POR)

10.1 Introduction

This section describes the power-on reset (POR) module (version B).

10.2 Functional Description

The POR module provides a known, stable signal to the MCU at power-on. This signal tracks V_{DD} until the MCU generates a feedback signal to indicate that it is properly initialized. At this time, the POR drives its output low. The POR is not a brown-out detector, low-voltage detector, or glitch detector. V_{DD} at the POR must go completely to 0 to reset the MCU. To detect power-loss conditions, use a low-voltage inhibit (LVI) module or other suitable circuit.

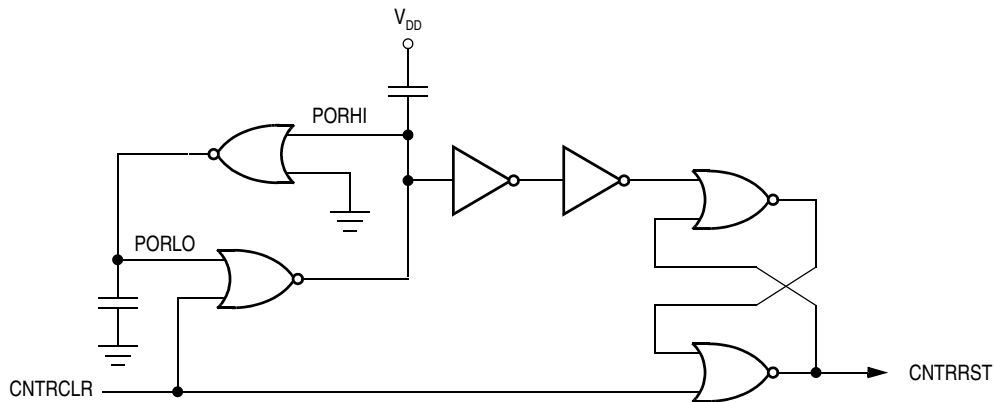

NOTES:

1. PORHI goes high at power-up and is cleared when the SIM sets CNTRCLR.
2. Signal names are not necessarily accurate. This diagram is for logical illustration only and may not represent actual circuitry.

Figure 10-1. POR Block Diagram

Chapter 11

External Interrupt Module (IRQ)

11.1 Introduction

This section describes the external interrupt (IRQ) module, which supports external interrupt functions.

11.2 Features

Features of the IRQ module include:

- Two dedicated external interrupt pins, $\overline{\text{IRQ1}}$ and $\overline{\text{IRQ2}}$
- Separate IRQ1 and IRQ2 interrupt masks
- IRQ2 interrupt disable
- Hysteresis buffers

11.3 Functional Description

A logic 0 applied to any of the external interrupt pins can latch a CPU interrupt request. [Figure 11-2](#) shows the structure of the IRQ module.

Interrupt signals on the $\overline{\text{IRQ1}}$ pin are latched into the IRQ1 latch. Interrupt signals on the $\overline{\text{IRQ2}}$ pin are latched into the IRQ2 interrupt latch. An interrupt latch remains set until one of the following actions occurs:

- Vector fetch — A vector fetch automatically generates an interrupt acknowledge signal that clears the latch that caused the vector fetch.
- Software clear — Software can clear an interrupt latch by writing to the appropriate acknowledge bit in the interrupt status and control register (ISCR). Writing a logic 1 to the ACK1 bit clears the IRQ1 latch. Writing a logic 1 to the ACK2 bit clears the IRQ2 interrupt latch.
- Reset — A reset automatically clears both interrupt latches.

| Addr. | Register Name | Bit 7 | 6 | 5 | 4 | 3 | 2 | 1 | Bit 0 | |
|--------|--|--------|------|------|--------|-------|---------|---|--------|-------|
| \$001D | IRQ Status and Control Register (ISCR) | Read: | PIN2 | 0 | IMASK2 | MODE2 | IRQ2DIS | 0 | IMASK1 | MODE1 |
| | | Write: | | ACK2 | | | | | | |
| | | Reset: | 0 | 0 | 0 | 0 | 0 | 0 | 0 | 0 |

= Unimplemented

Figure 11-1. IRQ I/O Register Summary

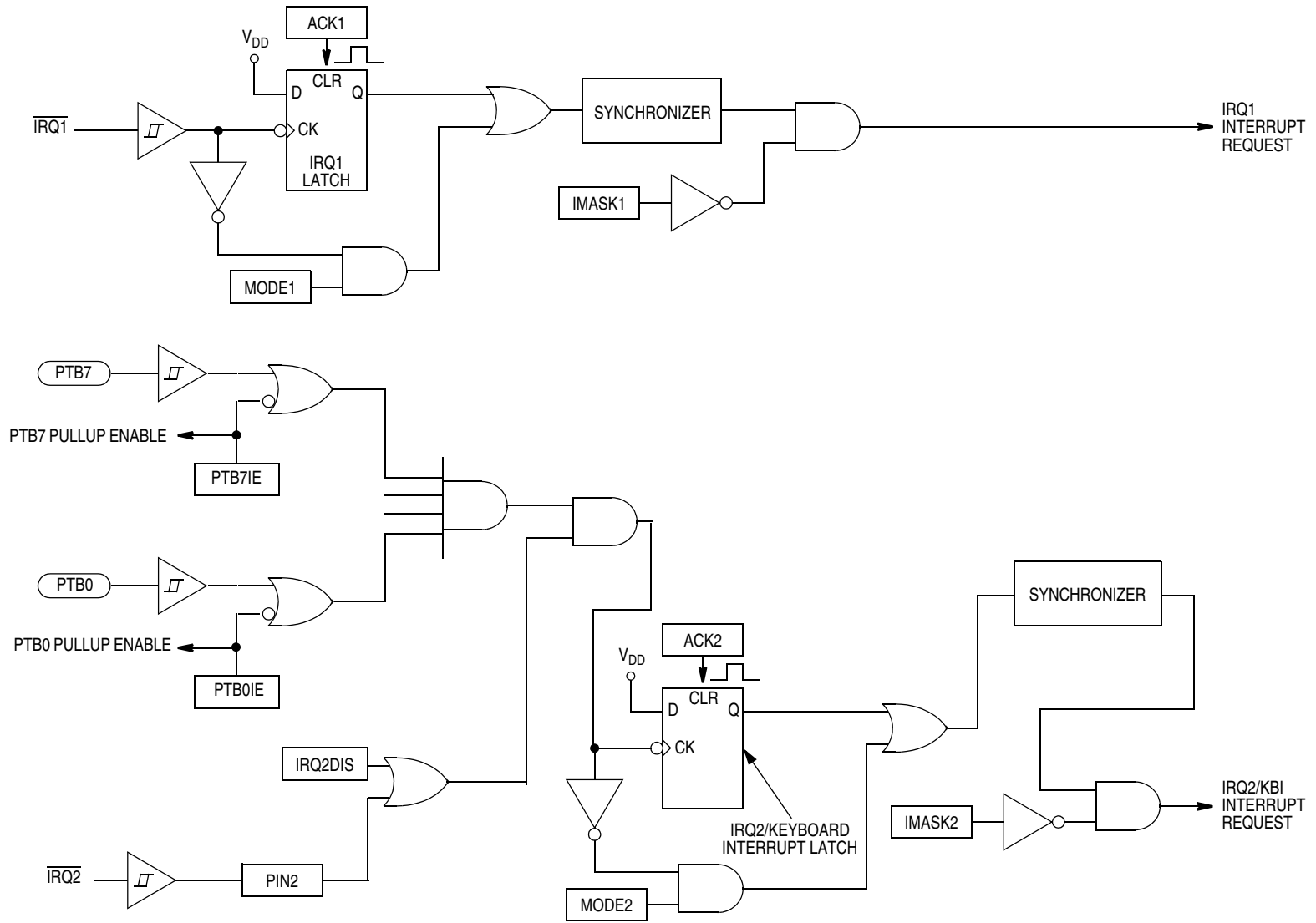

NOTE: IRQ2DIS does not prevent the reading of the state of the $\overline{\text{IRQ2}}$ pin in the IRQ status and control register (ISCR).

Figure 11-2. IRQ Module Block Diagram



All of the external interrupt pins are falling-edge-triggered and are software-configurable to be both falling-edge and low-level-triggered. The MODE1 bit in the ISCR controls the triggering sensitivity of the $\overline{\text{IRQ1}}$ pin. The MODE2 bit controls the triggering sensitivity of the $\overline{\text{IRQ2}}$ pin and the keyboard interrupt pins.

When an interrupt pin is edge-triggered only, the interrupt latch remains set until a vector fetch, software clear, or reset occurs.

When an interrupt pin is both falling-edge and low-level-triggered, the interrupt latch remains set until both of these occur:

- Vector fetch, software clear, or reset
- Return of the interrupt pin to logic 1

The vector fetch or software clear may occur before or after the interrupt pin returns to logic 1. As long as the pin is low, the interrupt request remains pending.

When set, the IMASK1 and IMASK2 bits in the ISCR mask all external interrupt requests. A latched interrupt request is not presented to the interrupt priority logic unless the corresponding IMASK bit is clear.

NOTE

*The interrupt mask (I) in the condition code register (CCR) masks all interrupt requests, including external interrupt requests.
(See [Figure 11-3](#).)*

11.3.1 $\overline{\text{IRQ1}}$ Pin

A logic 0 on the $\overline{\text{IRQ1}}$ pin can latch an interrupt request into the IRQ1 latch. A vector fetch, software clear, or reset clears the IRQ1 latch.

If the MODE1 bit is set, the $\overline{\text{IRQ1}}$ pin is both falling-edge-sensitive and low-level-sensitive. With MODE1 set, both of these actions must occur to clear the IRQ1 latch:

- Vector fetch, software clear, or reset — A vector fetch generates an interrupt acknowledge signal to clear the latch. Software may generate the interrupt acknowledge signal by writing a logic 1 to the ACK1 bit in the interrupt status and control register (ISCR). The ACK1 bit is useful in applications that poll the $\overline{\text{IRQ1}}$ pin and require software to clear the IRQ1 latch. Writing to the ACK1 bit can also prevent spurious interrupts due to noise. Setting ACK1 does not affect subsequent transitions on the $\overline{\text{IRQ1}}$ pin. A falling edge that occurs after writing to the ACK1 bit latches another interrupt request. If the IRQ1 mask bit, IMASK1, is clear, the CPU loads the program counter with the vector address at locations \$FFFA and \$FFFB.
- Return of the $\overline{\text{IRQ1}}$ pin to logic 1 — As long as the $\overline{\text{IRQ1}}$ pin is at logic 0, the IRQ1 latch remains set.

The vector fetch or software clear and the return of the $\overline{\text{IRQ1}}$ pin to logic 1 may occur in any order. The interrupt request remains pending as long as the $\overline{\text{IRQ1}}$ pin is at logic 0.

If the MODE1 bit is clear, the $\overline{\text{IRQ1}}$ pin is falling-edge-sensitive only. With MODE1 clear, a vector fetch or software clear immediately clears the IRQ1 latch.

Use the BIH or BIL instruction to read the logic level on the $\overline{\text{IRQ1}}$ pin.

NOTE

When using the level-sensitive interrupt trigger, avoid false interrupts by masking interrupt requests in the interrupt routine.

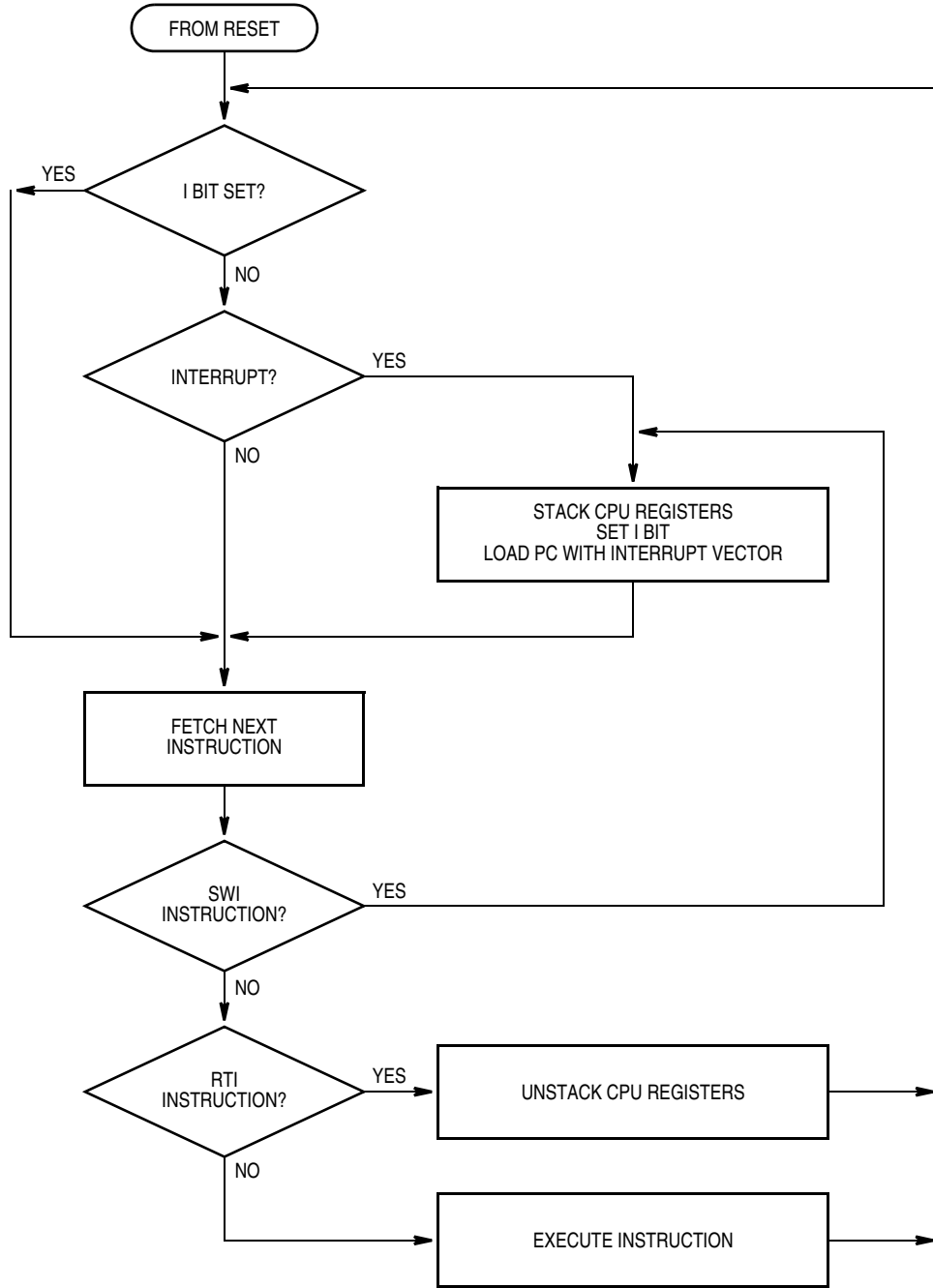

Figure 11-3. IRQ Interrupt Flowchart

11.3.2 $\overline{\text{IRQ2}}$ Pin

When the IRQ2DIS bit is clear, a logic 0 on the $\overline{\text{IRQ2}}$ pin can latch an interrupt request into the IRQ2 /keyboard interrupt latch. A vector fetch, software clear, or reset clears the IRQ2 /keyboard interrupt latch.

If the MODE2 bit is set, the $\overline{\text{IRQ2}}$ pin is both falling-edge-sensitive and low-level-sensitive. With MODE2 set, both of these actions must occur to clear the IRQ2 interrupt latch:

- Vector fetch, software clear, or reset — A vector fetch generates an interrupt acknowledge signal to clear the latch. Software may generate the interrupt acknowledge signal by writing a logic 1 to the ACK2 bit in the interrupt status and control register (ISCR). The ACK2 bit is useful in applications that poll the $\overline{\text{IRQ2}}$ pin and require software to clear the IRQ2 interrupt latch. Writing to the ACK2 bit can also prevent spurious interrupts due to noise. Setting ACK2 does not affect subsequent transitions on the $\overline{\text{IRQ2}}$ pin. A falling edge that occurs after writing to the ACK2 bit latches another interrupt request. If the IRQ2 mask bit, IMASK2, is clear, the CPU loads the program counter with the vector address at locations \$FFD2 and \$FFD3.
- Return of the $\overline{\text{IRQ2}}$ pin to logic 1 — As long as the $\overline{\text{IRQ2}}$ pin is at logic 0, the IRQ2 interrupt latch remains set.

The vector fetch or software clear and the return of the $\overline{\text{IRQ2}}$ pin to logic 1 may occur in any order. The interrupt request remains pending as long as the $\overline{\text{IRQ2}}$ pin is at logic 0.

If the MODE2 bit is clear, the $\overline{\text{IRQ2}}$ pin is falling-edge-sensitive only. With MODE2 clear, a vector fetch or software clear immediately clears the IRQ2 interrupt latch.

To determine the logic level on the $\overline{\text{IRQ2}}$ pin, read the $\overline{\text{IRQ2}}$ pin state bit, PIN2, in the ISCR. This bit reflects the value of the $\overline{\text{IRQ2}}$ pin, even when the $\overline{\text{IRQ2DIS}}$ bit is set.

NOTE

See [Chapter 19 Keyboard Interrupt \(KBI\) Module](#) for more information about keyboard interrupt.

11.4 IRQ Module During Break Interrupts

The system integration module (SIM) controls whether the IRQ1 and IRQ2 interrupt latches can be cleared during the break state. The BCFE bit in the SIM break flag control register (SBFCR) enables software to clear the latches during the break state. (See [6.7.3 SIM Break Flag Control Register](#).)

To allow software to clear the IRQ1 latch and the IRQ2 interrupt latch during a break interrupt, write a logic 1 to the BCFE bit. If a latch is cleared during the break state, it remains cleared when the MCU exits the break state.

To protect the latches during the break state, write a logic 0 to the BCFE bit. With BCFE at logic 0 (its default state), writing to the ACK1 and ACK2 bits in the IRQ status and control register during the break state has no effect on the IRQ latches. See [11.5 IRQ Status and Control Register](#).

11.5 IRQ Status and Control Register

The IRQ status and control register (ISCR) controls and monitors operation of the IRQ module. It has these functions:

- Shows current state of $\overline{\text{IRQ2}}$ pin
- Clears the IRQ1 and IRQ2 interrupt latches
- Masks IRQ1 and IRQ2 interrupt requests
- Controls triggering sensitivity of the $\overline{\text{IRQ1}}$ and $\overline{\text{IRQ2}}$ interrupt pins
- Disables IRQ2 interrupt requests

External Interrupt Module (IRQ)

Address: \$001D

| | Bit 7 | 6 | 5 | 4 | 3 | 2 | 1 | Bit 0 |
|--------|-------|------|--------|-------|---------|------|--------|-------|
| Read: | PIN2 | 0 | IMASK2 | MODE2 | IRQ2DIS | 0 | IMASK1 | MODE1 |
| Write: | | ACK2 | | | | ACK1 | | |
| Reset: | 0 | 0 | 0 | 0 | 0 | 0 | 0 | 0 |

 = Unimplemented

Figure 11-4. IRQ Status and Control Register (ISCR)

PIN2 — $\overline{\text{IRQ2}}$ pin state bit

This read-only bit reflects the current logic level of the $\overline{\text{IRQ2}}$ pin.

1 = $\overline{\text{IRQ2}}$ pin at logic 1

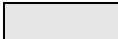
0 = $\overline{\text{IRQ2}}$ pin at logic 0

ACK2 — IRQ2 interrupt request acknowledge bit

Writing a logic 1 to this write-only bit clears the IRQ2/keyboard interrupt latch. ACK2 always reads as logic 0. Reset clears ACK2.

IMASK2 — IRQ2 interrupt mask bit

Writing a logic 1 to this read/write bit prevents the output of the IRQ2/keyboard interrupt latch from generating interrupt requests. Reset clears IMASK2.

1 = $\overline{\text{IRQ2}}$ pin interrupt request disabled

0 = $\overline{\text{IRQ2}}$ pin interrupt request enabled

MODE2 — IRQ2/keyboard interrupt edge/level select bit

This read/write bit controls the triggering sensitivity of the $\overline{\text{IRQ2}}$ interrupt pin. Reset clears MODE2.

1 = $\overline{\text{IRQ2}}$ interrupt request on falling edges and low levels

0 = $\overline{\text{IRQ2}}$ interrupt request on falling edges only

IRQ2DIS — $\overline{\text{IRQ2}}$ pin interrupt latch disable bit

This read/write bit prevents the $\overline{\text{IRQ2}}$ pin from latching interrupt requests into the IRQ2 interrupt latch. Reset clears IRQ2DIS.

1 = $\overline{\text{IRQ2}}$ pin interrupt requests not latched

0 = $\overline{\text{IRQ2}}$ pin interrupt requests latched

ACK1 — IRQ1 interrupt request acknowledge bit

Writing a logic 1 to this write-only bit clears the IRQ1 latch. ACK1 always reads as logic 0. Reset clears ACK1.

IMASK1 — IRQ1 interrupt mask bit

Writing a logic 1 to this read/write bit disables IRQ1 interrupt requests. Reset clears IMASK1.

1 = IRQ1 interrupt requests disabled

0 = IRQ1 interrupt requests enabled

MODE1 — IRQ1 edge/level select bit

This read/write bit controls the triggering sensitivity of the $\overline{\text{IRQ1}}$ pin. Reset clears MODE1.

1 = $\overline{\text{IRQ1}}$ interrupt request on falling edges and low levels

0 = $\overline{\text{IRQ1}}$ interrupt request on falling edges only

Chapter 12

Infrared Serial Communications Interface (IrSCI)

12.1 Introduction

This section describes the infrared serial communications interface (IrSCI) module which allows high-speed asynchronous communications with peripheral devices and other MCUs.

NOTE

References to DMA (direct memory access) and associated functions are only valid if the MCU has a DMA module. This MCU does not have the DMA function. Any DMA-related register bits should be left in their reset state for normal MCU operation.

12.2 Features

Features of the IrSCI module include:

- Full duplex operation
- Software selectable infrared modulation/demodulation (3/16, 1/16, or 1/32)
- Standard mark/space non-return-to-zero (NRZ) format
- Programmable 8-bit or 9-bit character length
- Separately enabled transmitter and receiver
- Separate receiver and transmitter CPU interrupt requests
- Two receiver wakeup methods:
 - Idle line wakeup
 - Address mark wakeup
- Interrupt-driven operation with eight interrupt flags:
 - Transmitter empty
 - Transmission complete
 - Receiver full
 - Idle receiver input
 - Receiver overrun
 - Noise error
 - Framing error
 - Parity error
- Receiver framing error detection
- Hardware parity checking
- 1/16 bit-time noise detection

12.3 IrSCI Module Overview

The IrSCI consists of a modified serial communications interface (SCI) and the infrared interface submodule as shown in [Figure 12-1](#). The infrared block receives two clock sources from the SCI, SCI_R16XCLK and SCI_R32XCLK, which are configured to generate the narrow pulse width during transmission. The SCI_R16XCLK and SCI_R32XCLK are internal clocks with frequencies 16 and 32 times the baud rate, respectively. Both SCI_R16XCLK and SCI_R32XCLK clocks are used for transmitting data. The SCI_R16XCLK clock is used only for receiving data.

The infrared submodule consists of two major blocks: the transmit encoder and the receive decoder which will be discussed in [12.4 Infrared Functional Description](#). The SCI transmits serial bits of data which are encoded by the infrared submodule to transmit a narrow low pulse for every zero bit. No low pulse is transmitted for every one bit. When receiving data, the IR pulses should be detected using an IR photo diode and transformed to CMOS levels by the IR receive decoder (external from the MCU). The zero pulses are then stretched by the infrared submodule to return to a serial bit stream to be received by the SCI.

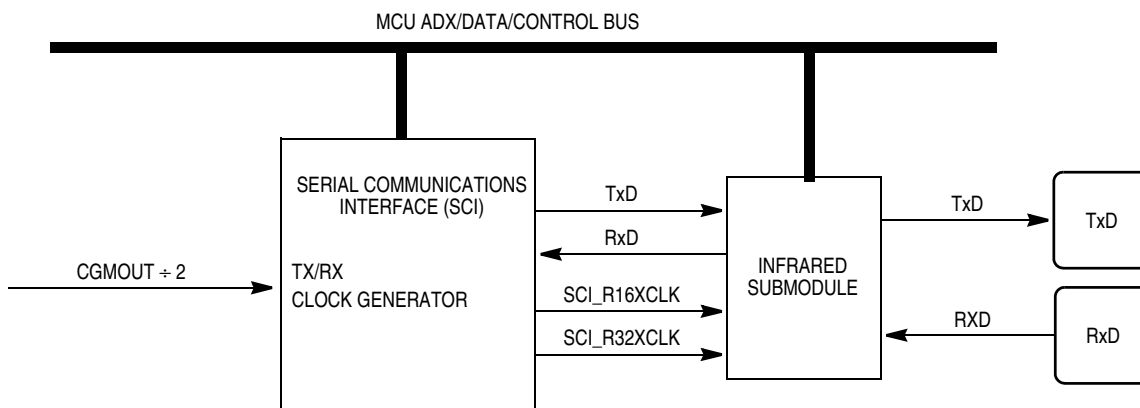

Figure 12-1. SCI and IR System Block Diagram

CAUTION

For proper SCI function (transmit or receive), the bus clock (CGMOUT ÷ 2) MUST be programmed to at least 32 times that of the selected baud rate.

NOTE

When the infrared submodule is disabled, pins TxD and RxD pass through unchanged to the SCI.

12.4 Infrared Functional Description

The infrared submodule consists of two major blocks: a transmit encoder and a receive decoder as shown in Figure 12-2.

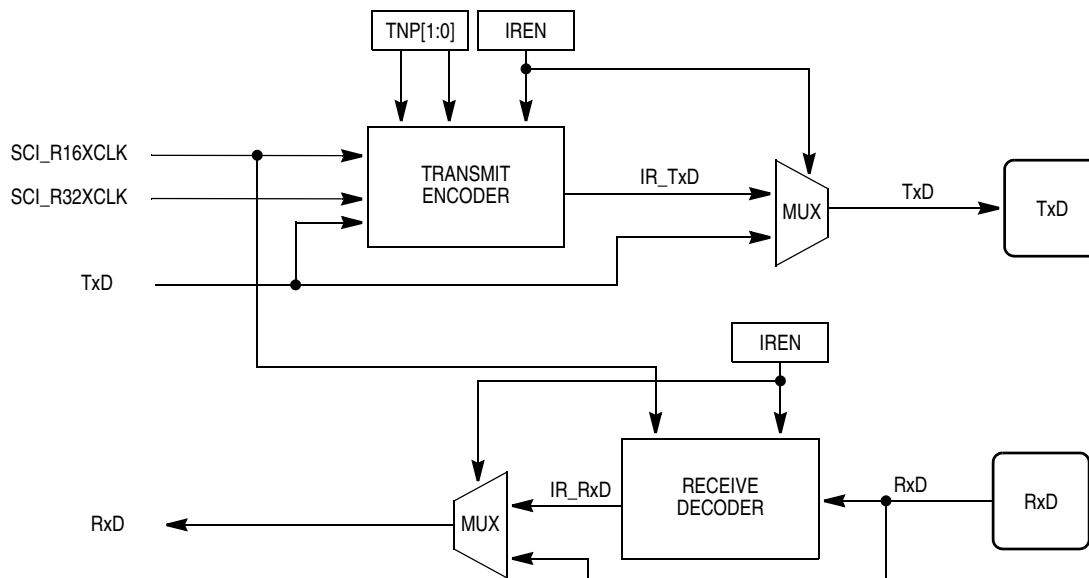

Figure 12-2. Infrared Submodule Diagram

This module provides the capability of transmitting narrow pulses to the IR LED and receiving narrow pulses and transforming them to serial bits, which are sent to the SCI. The infrared submodule receives its clock sources from the SCI. One of these two clocks are selected in the infrared submodule to generate either 3/16, 1/16, or 1/32 narrow pulses during transmission.

12.4.1 Infrared Transmit Encoder

The infrared transmit block converts serial bits of data from the SCI module to narrow low pulses (pin TxD) when a zero bit in the serial stream is received. The narrow pulse is sent in the middle of the bit with a duration of 1/32, 1/16, or 3/16 of a bit time. When two 0s are sent, the first narrow pulse is sent in the middle of the bit, and then after one bit time, another narrow pulse is sent in the middle of the second bit.

12.4.2 Infrared Receive Decoder

The infrared receive block converts low narrow pulses from pin RxD to standard SCI data bits using the SCI_R16XCK clock. This signal clocks a 4-bit internal counter which ranges from 0 to 15. The incoming pulse enables the internal counter and a 0 is sent out to the Ir_RXD output. If a second pulse or several pulses occur between count 0 and 7, these pulses are ignored. When the counter is greater than 7, and if another pulse occurs, the counter is reset and the Ir_RXD output remains 0. After the counter reaches 15, the Ir_RXD output returns to 1. The circuit then waits for another input pulse and the process is repeated. If a pulse arrives shortly after the counter reaches 15 due to jitter, the Ir_RXD output remains 1 until the pulse occurs. Then a 0 is sent out to Ir_RXD.

12.5 SCI Functional Description

These changes are made to the standard SCI which is used in MC68HC(9)08LJ60:

- The prescaler is eliminated (including the divide-by-4 stage) to minimize the input frequency and allow for the 32X clock needed for IR modulation.
- The TXINV bit is removed from SCC1.
- The pin control logic was changed to allow for separate enable/disable of the RXD and/or TXD pads based upon whether the associated function is enabled.
- The clock input to the baud rate generator is NOT divided by 4. For example, the baud rate equation is different by a factor of 4.

Figure 12-4 shows the structure of the SCI. The SCI allows full-duplex, asynchronous, NRZ serial communication between the MCU and remote devices, including other MCUs. The transmitter and receiver of the SCI operate independently, although they use the same baud rate generator. During normal operation, the CPU monitors the status of the SCI, writes the data to be transmitted, and processes received data.

| Addr. | Register Name | Bit 7 | 6 | 5 | 4 | 3 | 2 | 1 | Bit 0 | |
|--------|--|--------|---------------------|-------|-------|-------|------|------|-------|------|
| \$0013 | SCI Control Register 1 (SCC1) | Read: | LOOPS | ENSCI | 0 | M | WAKE | ILTY | PEN | PTY |
| | | Write: | | | | | | | | |
| | | Reset: | 0 | 0 | 0 | 0 | 0 | 0 | 0 | 0 |
| \$0014 | SCI Control Register 2 (SCC2) | Read: | SCTIE | TCIE | SCRIE | ILIE | TE | RE | RWU | SBK |
| | | Write: | | | | | | | | |
| | | Reset: | 0 | 0 | 0 | 0 | 0 | 0 | 0 | 0 |
| \$0015 | SCI Control Register 3 (SCC3) | Read: | R8 | T8 | DMARE | DMATE | ORIE | NEIE | FEIE | PEIE |
| | | Write: | | | | | | | | |
| | | Reset: | U | U | 0 | 0 | 0 | 0 | 0 | 0 |
| \$0016 | SCI Status Register 1 (SCS1) | Read: | SCTE | TC | SCRf | IDLE | OR | NF | FE | PE |
| | | Write: | | | | | | | | |
| | | Reset: | 1 | 1 | 0 | 0 | 0 | 0 | 0 | 0 |
| \$0017 | SCI Status Register 2 (SCS2) | Read: | | | | | | | BKF | RPF |
| | | Write: | | | | | | | | |
| | | Reset: | 0 | 0 | 0 | 0 | 0 | 0 | 0 | 0 |
| \$0018 | SCI Data Register (SCDR) | Read: | R7 | R6 | R5 | R4 | R3 | R2 | R1 | R0 |
| | | Write: | T7 | T6 | T5 | T4 | T3 | T2 | T1 | T0 |
| | | Reset: | Unaffected by reset | | | | | | | |
| \$0019 | SCI Baud Rate Register (SCBR) | Read: | 0 | 0 | 0 | 0 | 0 | SCR2 | SCR1 | SCR0 |
| | | Write: | | | | | | | | |
| | | Reset: | 0 | 0 | 0 | 0 | 0 | 0 | 0 | 0 |
| \$001E | SCI Infrared Control Register (SCIRCR) | Read: | 0 | 0 | 0 | 0 | 0 | TNP1 | TNP0 | IREN |
| | | Write: | | | | | | | | |
| | | Reset: | 0 | 0 | 0 | 0 | 0 | 0 | 0 | 0 |

= Unimplemented U = Undetermined

Figure 12-3. IrSCI I/O Register Summary

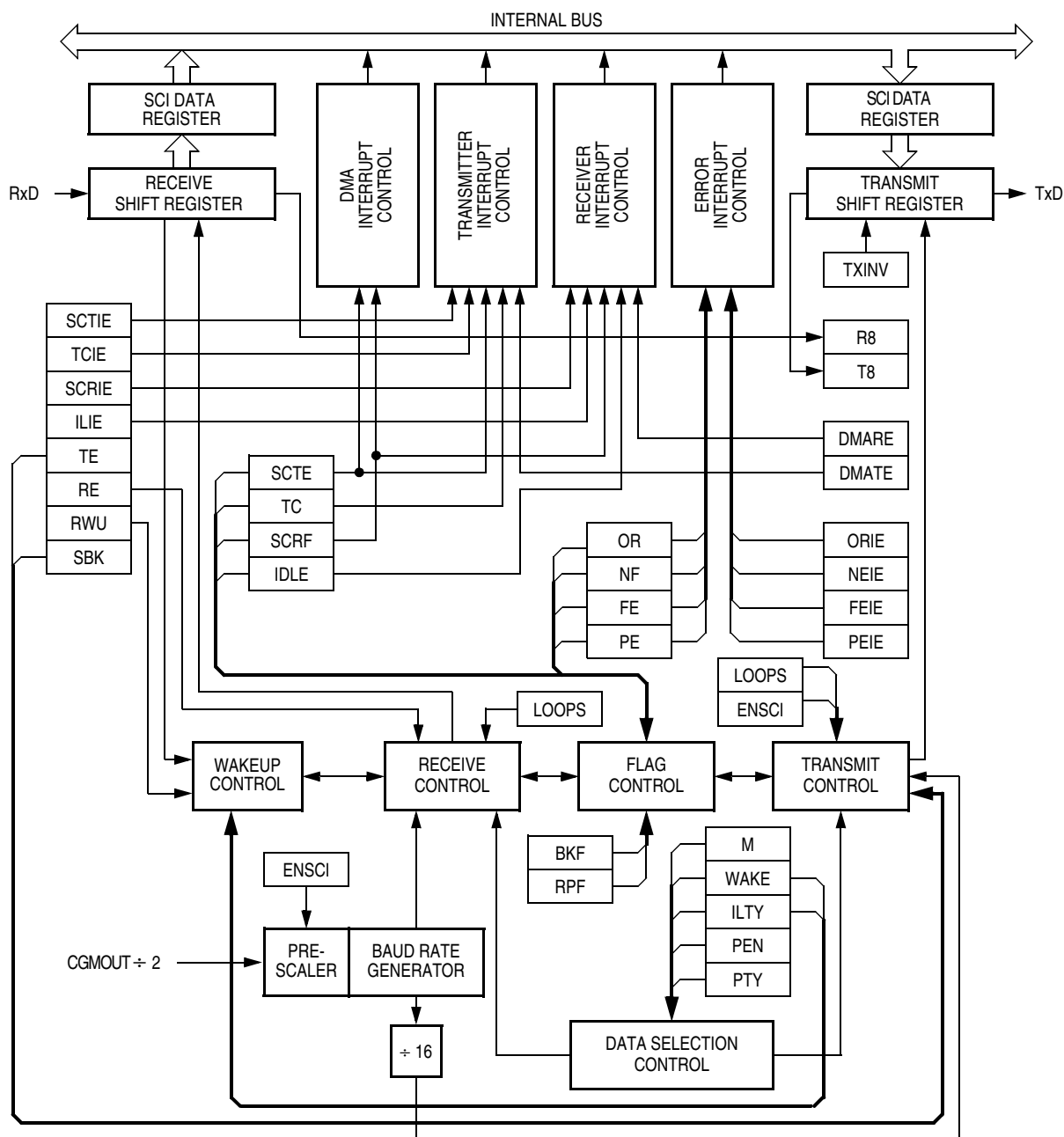

Figure 12-4. SCI Module Block Diagram

12.5.1 Data Format

The SCI uses the standard non-return-to-zero mark/space data format illustrated in [Figure 12-5](#).

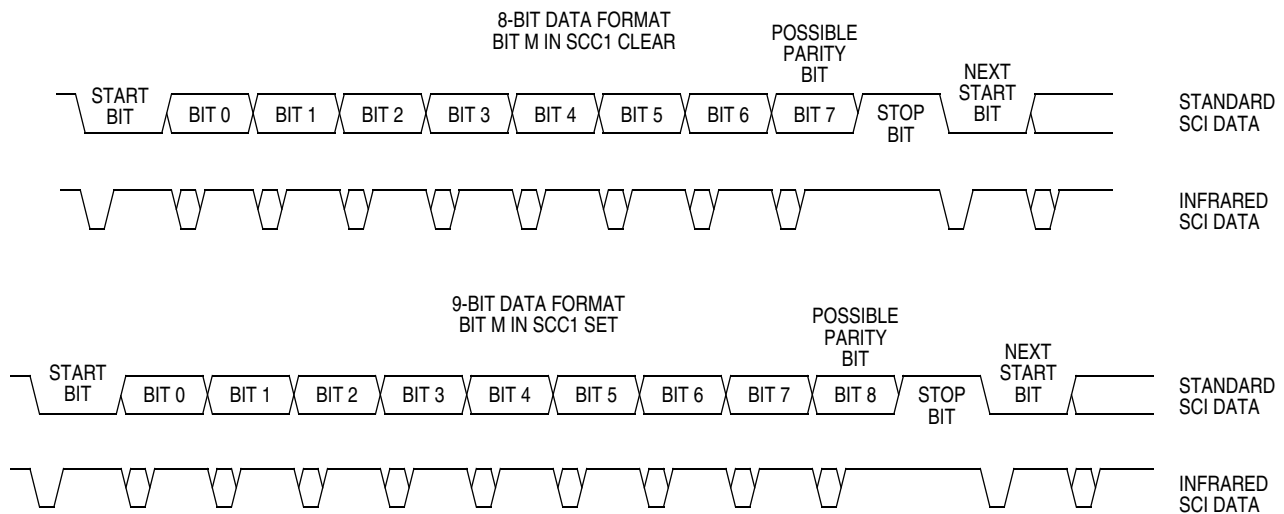

Figure 12-5. SCI Data Formats (8-Bit/9-Bit for Standard SCI and Infrared)

12.5.2 Transmitter

[Figure 12-6](#) shows the structure of the SCI transmitter.

NOTE

The transmission output pin is enabled by TE bit of SCC2 instead of ENSCI bit of SCC1.

12.5.2.1 Character Length

The transmitter can accommodate either 8-bit or 9-bit data. The state of the M bit in SCI control register 1 (SCC1) determines character length. When transmitting 9-bit data, bit T8 in SCI control register 3 (SCC3) is the ninth bit (bit 8).

12.5.2.2 Character Transmission

During an SCI transmission, the transmit shift register shifts a character out to the TxD pin. The SCI data register (SCDR) is the write-only buffer between the internal data bus and the transmit shift register.

To initiate an SCI transmission:

1. Enable the SCI by writing a logic 1 to the enable SCI bit (ENSCI) in SCI control register 1 (SCC1).
2. Enable the transmitter by writing a logic 1 to the transmitter enable bit (TE) in SCI control register 2 (SCC2).
3. Clear the SCI transmitter empty bit by first reading SCI status register 1 (SCS1) and then writing to the SCDR.
4. Repeat step 3 for each subsequent transmission.

At the start of a transmission, transmitter control logic automatically loads the transmit shift register with a preamble of logic 1s. After the preamble shifts out, control logic transfers the SCDR data into the transmit shift register. A logic 0 start bit automatically goes into the least significant bit (LSB) position of the transmit shift register. A logic 1 stop bit goes into the most significant bit (MSB) position.

The SCI transmitter empty bit, SCTE, in SCS1 becomes set when the SCDR transfers a byte to the transmit shift register. The SCTE bit indicates that the SCDR can accept new data from the internal data bus. If the SCI transmit interrupt enable bit, SCTIE, in SCC2 is also set, the SCTE bit generates a transmitter interrupt request.

When the transmit shift register is not transmitting a character, the TxD pin goes to the idle condition, logic 1 (in either standard or infrared modes). If at any time software clears the ENSCI bit in SCI control register 1 (SCC1), the transmitter and receiver relinquish control of the SCI pins.

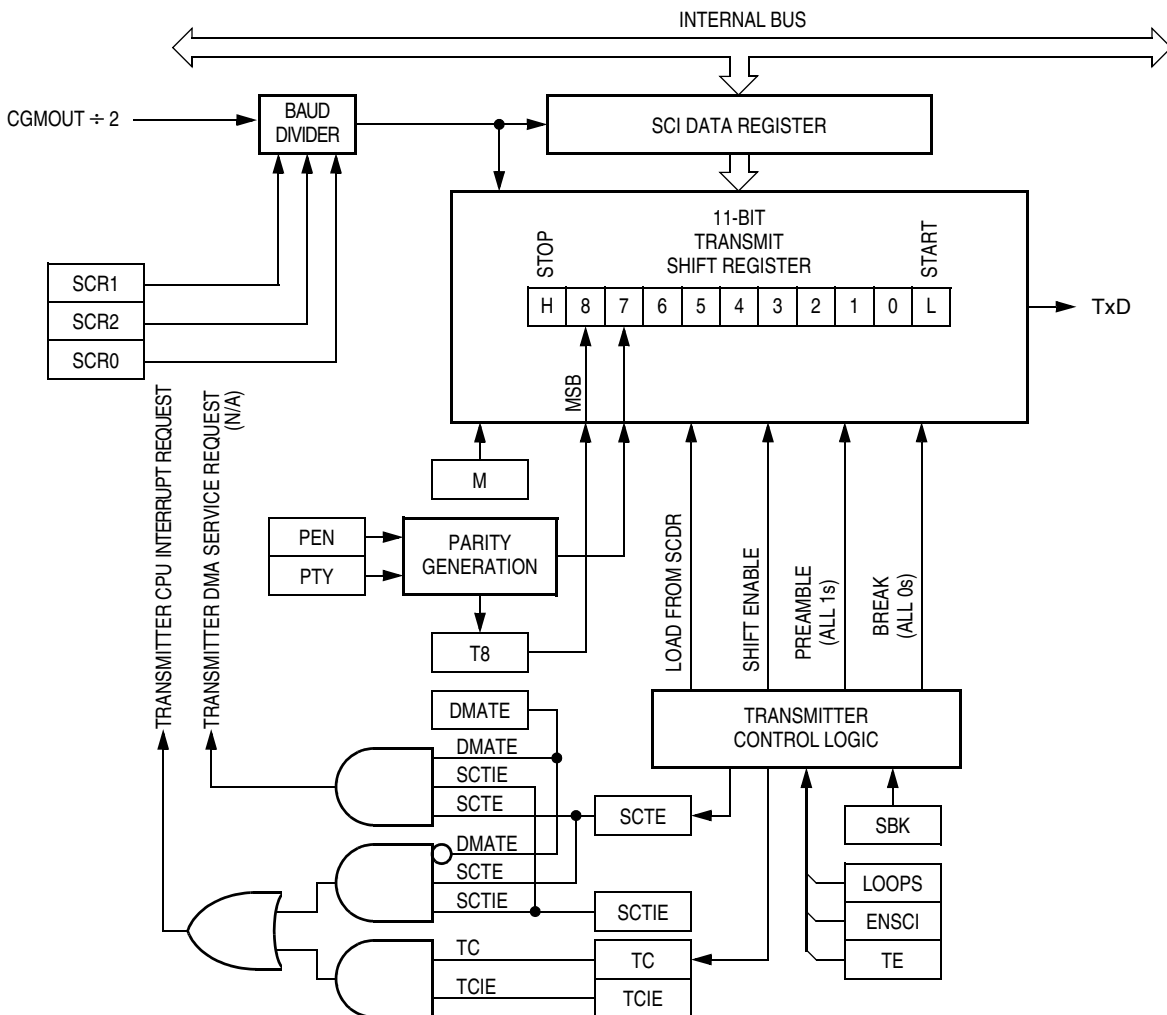

Figure 12-6. SCI Transmitter

12.5.2.3 Break Characters

Writing a logic 1 to the send break bit, SBK, in SCC2 loads the transmit shift register with a break character. A break character contains all logic 0s and has no start, stop, or parity bit. Break character length depends on the M bit in SCC1. As long as SBK is at logic 1, transmitter logic continuously loads break characters into the transmit shift register. After software clears the SBK bit, the shift register finishes transmitting the last break character and then transmits at least one logic 1. The automatic logic 1 at the end of a break character guarantees the recognition of the start bit of the next character.

The SCI recognizes a break character when a start bit is followed by eight or nine logic 0 data bits and a logic 0 where the stop bit should be.

Receiving a break character has these effects on SCI registers:

- Sets the framing error bit (FE) in SCS1
- Sets the SCI receiver full bit (SCRF) in SCS1
- Clears the SCI data register (SCDR)
- Clears the R8 bit in SCC3
- Sets the break flag bit (BKF) in SCS2
- May set the overrun (OR), noise flag (NF), parity error (PE), or reception-in-progress flag (RPF) bits

12.5.2.4 Idle Characters

An idle character contains all logic 1s and has no start, stop, or parity bit. Idle character length depends on the M bit in SCC1. The preamble is a synchronizing idle character that begins every transmission.

If the TE bit is cleared during a transmission, the TxD pin becomes idle after completion of the transmission in progress. Clearing and then setting the TE bit during a transmission queues an idle character to be sent after the character currently being transmitted.

NOTE

When queueing an idle character, return the TE bit to logic 1 before the stop bit of the current character shifts out to the TxD pin. Setting TE after the stop bit appears on TxD causes data previously written to the SCDR to be lost.

A good time to toggle the TE bit is when the SCTE bit becomes set and just before writing the next byte to the SCDR.

12.5.2.5 Transmitter Interrupts

These conditions can generate CPU interrupt requests from the SCI transmitter:

- SCI transmitter empty (SCTE) — The SCTE bit in SCS1 indicates that the SCDR has transferred a character to the transmit shift register. SCTE can generate a transmitter CPU interrupt request. Setting the SCI transmit interrupt enable bit, SCTIE, in SCC2 enables the SCTE bit to generate transmitter CPU interrupt requests.
- Transmission complete (TC) — The TC bit in SCS1 indicates that the transmit shift register and the SCDR are empty and that no break or idle character has been generated. The transmission complete interrupt enable bit, TCIE, in SCC2 enables the TC bit to generate transmitter CPU interrupt requests.

12.5.3 Receiver

Figure 12-7 shows the structure of the SCI receiver.

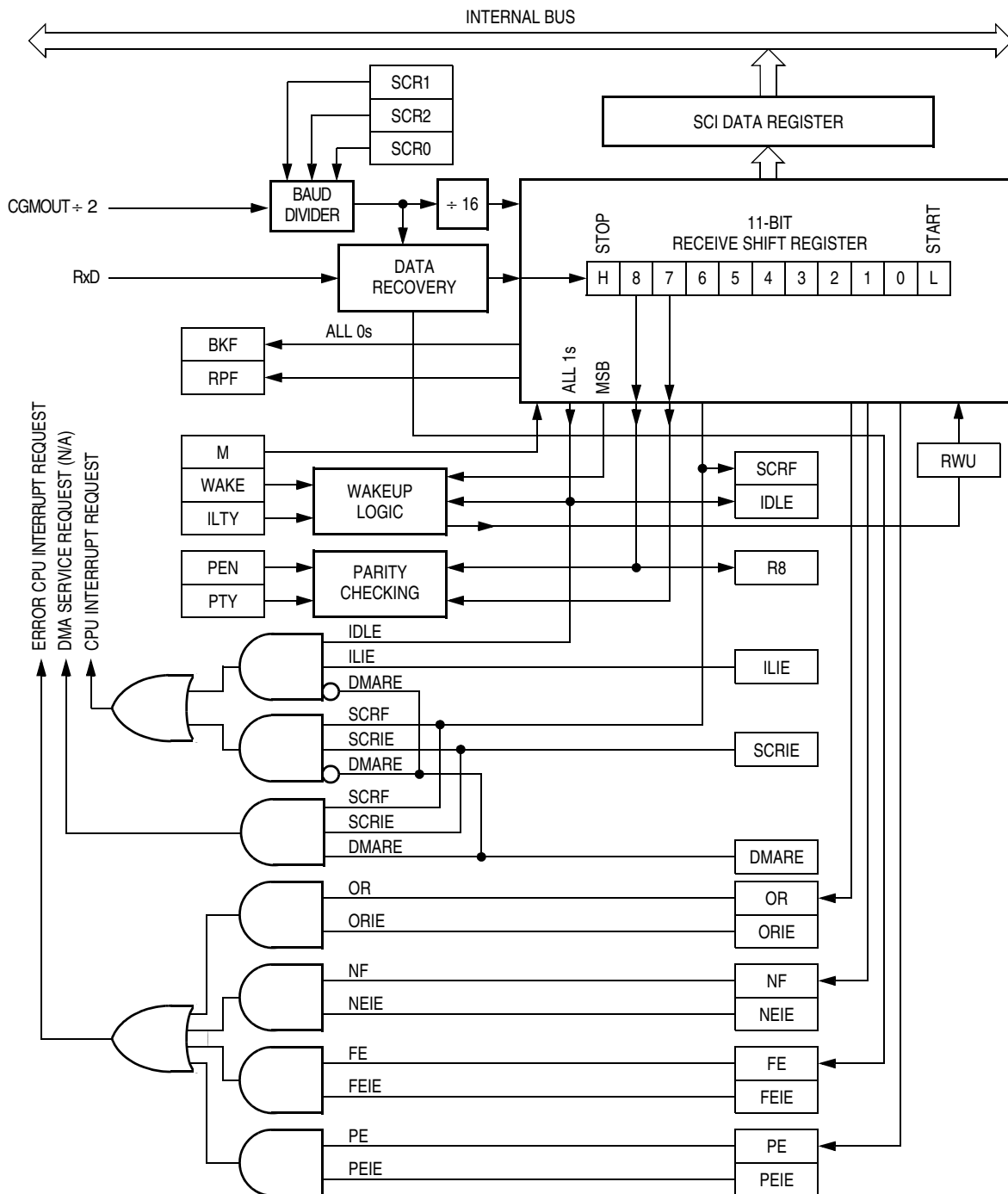

Figure 12-7. SCI Receiver Block Diagram

12.5.3.1 Character Length

The receiver can accommodate either 8-bit or 9-bit data. The state of the M bit in SCI control register 1 (SCC1) determines character length. When receiving 9-bit data, bit R8 in SCI control register 2 (SCC2) is the ninth bit (bit 8). When receiving 8-bit data, bit R8 is a copy of the eighth bit (bit 7).

12.5.3.2 Character Reception

During an SCI reception, the receive shift register shifts characters in from the RxD pin. The SCI data register (SCDR) is the read-only buffer between the internal data bus and the receive shift register.

After a complete character shifts into the receive shift register, the data portion of the character transfers to the SCDR. The SCI receiver full bit, SCRF, in SCI status register 1 (SCS1) becomes set, indicating that the received byte can be read. If the SCI receive interrupt enable bit, SCRIE, in SCC2 is also set, the SCRF bit generates a receiver CPU interrupt request.

12.5.3.3 Data Sampling

The receiver samples the RxD pin at the RT clock rate. The RT clock is an internal signal with a frequency 16 times the baud rate. To adjust for baud rate mismatch, the RT clock is resynchronized at the following times (see Figure 12-8):

- After every start bit
- After the receiver detects a data bit change from logic 1 to logic 0 (after the majority of data bit samples at RT8, RT9, and RT10 returns a valid logic 1 and the majority of the next RT8, RT9, and RT10 samples returns a valid logic 0)

To locate the start bit, data recovery logic does an asynchronous search for a logic 0 preceded by three logic 1s. When the falling edge of a possible start bit occurs, the RT clock begins to count to 16.

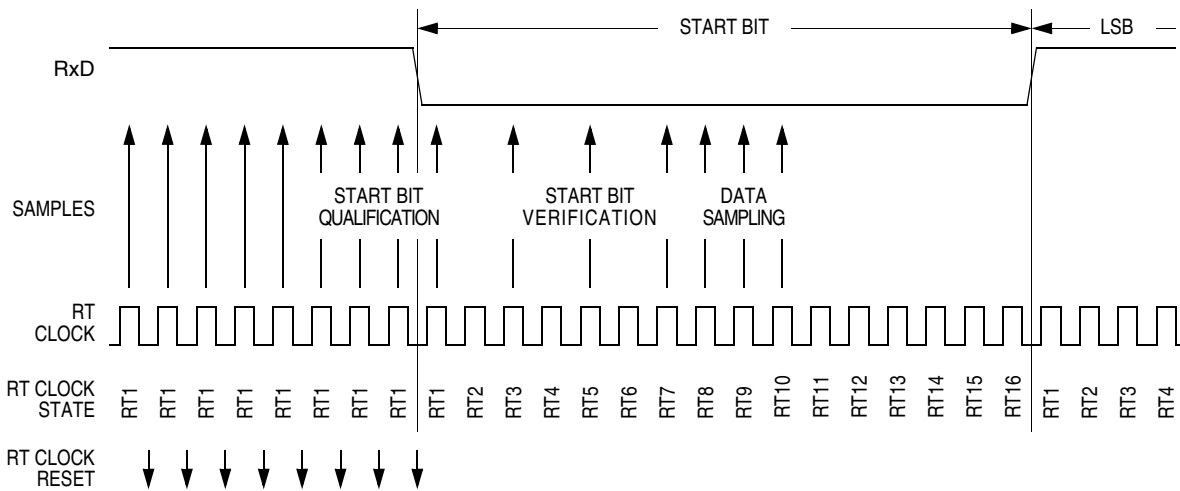

Figure 12-8. Receiver Data Sampling

To verify the start bit and to detect noise, data recovery logic takes samples at RT3, RT5, and RT7. [Table 12-1](#) summarizes the results of the start bit verification samples.

Table 12-1. Start Bit Verification

| RT3, RT5, and RT7 samples | Start bit verification | Noise flag |
|---------------------------|------------------------|------------|
| 000 | Yes | 0 |
| 001 | Yes | 1 |
| 010 | Yes | 1 |
| 011 | No | 0 |
| 100 | Yes | 1 |
| 101 | No | 0 |
| 110 | No | 0 |
| 111 | No | 0 |

If start bit verification is not successful, the RT clock is reset and a new search for a start bit begins.

To determine the value of a data bit and to detect noise, recovery logic takes samples at RT8, RT9, and RT10. [Table 12-2](#) summarizes the results of the data bit samples.

Table 12-2. Data Bit Recovery

| RT8, RT9, and RT10 samples | Data bit determination | Noise flag |
|----------------------------|------------------------|------------|
| 000 | 0 | 0 |
| 001 | 0 | 1 |
| 010 | 0 | 1 |
| 011 | 1 | 1 |
| 100 | 0 | 1 |
| 101 | 1 | 1 |
| 110 | 1 | 1 |
| 111 | 1 | 0 |

NOTE

The RT8, RT9, and RT10 samples do not affect start bit verification. If any or all of the RT8, RT9, and RT10 start bit samples are logic 1s following a successful start bit verification, the noise flag (NF) is set and the receiver assumes that the bit is a start bit.

To verify a stop bit and to detect noise, recovery logic takes samples at RT8, RT9, and RT10. [Table 12-3](#) summarizes the results of the stop bit samples.

Table 12-3. Stop Bit Recovery

| RT8, RT9, and RT10 samples | Framing error flag | Noise flag |
|----------------------------|--------------------|------------|
| 000 | 1 | 0 |
| 001 | 1 | 1 |
| 010 | 1 | 1 |
| 011 | 0 | 1 |
| 100 | 1 | 1 |
| 101 | 0 | 1 |
| 110 | 0 | 1 |
| 111 | 0 | 0 |

12.5.3.4 Framing Errors

If the data recovery logic does not detect a logic 1 where the stop bit should be in an incoming character, it sets the framing error bit, FE, in SCS1. The FE flag is set at the same time that the SCRF bit is set. A break character that has no stop bit also sets the FE bit.

12.5.3.5 Baud Rate Tolerance

A transmitting device may be operating at a baud rate below or above the receiver baud rate. Accumulated bit time misalignment can cause one of the three stop bit data samples to fall outside the actual stop bit. Then a noise error occurs. If more than one of the samples is outside the stop bit, a framing error occurs. In most applications, the baud rate tolerance is much more than the degree of misalignment that is likely to occur.

As the receiver samples an incoming character, it resynchronizes the RT clock on any valid falling edge within the character. Resynchronization within characters corrects misalignments between transmitter bit times and receiver bit times.

Slow Data Tolerance

Figure 12-9 shows how much a slow received character can be misaligned without causing a noise error or a framing error. The slow stop bit begins at RT8 instead of RT1 but arrives in time for the stop bit data samples at RT8, RT9, and RT10.

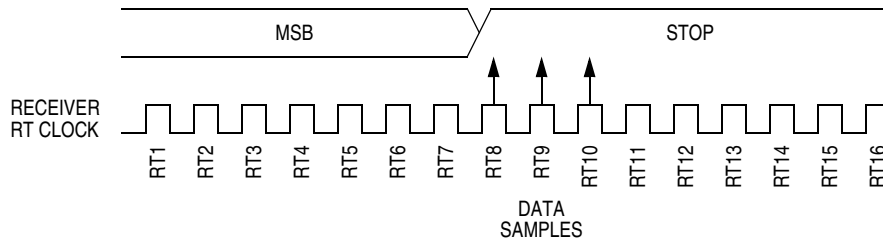

Figure 12-9. Slow Data

For an 8-bit character, data sampling of the stop bit takes the receiver
 $9 \text{ bit times} \times 16 \text{ RT cycles} + 10 \text{ RT cycles} = 154 \text{ RT cycles}$.

With the misaligned character shown in Figure 12-9, the receiver counts 154 RT cycles at the point when the count of the transmitting device is $9 \text{ bit times} \times 16 \text{ RT cycles} + 3 \text{ RT cycles} = 147 \text{ RT cycles}$.

The maximum percent difference between the receiver count and the transmitter count of a slow 8-bit character with no errors is

$$\left| \frac{154 - 147}{154} \right| \times 100 = 4.54\%$$

For a 9-bit character, data sampling of the stop bit takes the receiver
 $10 \text{ bit times} \times 16 \text{ RT cycles} + 10 \text{ RT cycles} = 170 \text{ RT cycles}$.

With the misaligned character shown in Figure 12-9, the receiver counts 170 RT cycles at the point when the count of the transmitting device is

$10 \text{ bit times} \times 16 \text{ RT cycles} + 3 \text{ RT cycles} = 163 \text{ RT cycles}$.

The maximum percent difference between the receiver count and the transmitter count of a slow 9-bit character with no errors is

$$\left| \frac{170 - 163}{170} \right| \times 100 = 4.12\%$$

Fast Data Tolerance

Figure 12-10 shows how much a fast received character can be misaligned without causing a noise error or a framing error. The fast stop bit ends at RT10 instead of RT16 but is still there for the stop bit data samples at RT8, RT9, and RT10.

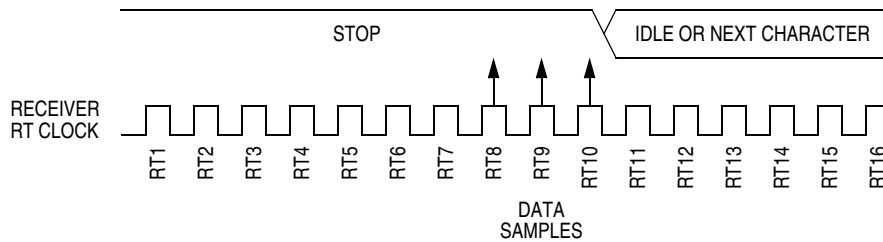

Figure 12-10. Fast Data

For an 8-bit character, data sampling of the stop bit takes the receiver $9 \text{ bit times} \times 16 \text{ RT cycles} + 10 \text{ RT cycles} = 154 \text{ RT cycles}$.

With the misaligned character shown in Figure 12-10, the receiver counts 154 RT cycles at the point when the count of the transmitting device is $10 \text{ bit times} \times 16 \text{ RT cycles} = 160 \text{ RT cycles}$.

The maximum percent difference between the receiver count and the transmitter count of a fast 8-bit character with no errors is

$$\left| \frac{154 - 160}{154} \right| \times 100 = 3.90\%$$

For a 9-bit character, data sampling of the stop bit takes the receiver $10 \text{ bit times} \times 16 \text{ RT cycles} + 10 \text{ RT cycles} = 170 \text{ RT cycles}$.

With the misaligned character shown in Figure 12-10, the receiver counts 170 RT cycles at the point when the count of the transmitting device is $11 \text{ bit times} \times 16 \text{ RT cycles} = 176 \text{ RT cycles}$.

The maximum percent difference between the receiver count and the transmitter count of a fast 9-bit character with no errors is

$$\left| \frac{170 - 176}{170} \right| \times 100 = 3.53\%$$

12.5.3.6 Receiver Wakeup

So that the MCU can ignore transmissions intended only for other receivers in multiple-receiver systems, the receiver can be put into a standby state. Setting the receiver wakeup bit, RWU, in SCC2 puts the receiver into a standby state during which receiver interrupts are disabled.

Depending on the state of the WAKE bit in SCC1, either of two conditions on the RxD pin can bring the receiver out of the standby state:

- Address mark — An address mark is a logic 1 in the most significant bit position of a received character. When the WAKE bit is set, an address mark wakes the receiver from the standby state by clearing the RWU bit. The address mark also sets the SCI receiver full bit, SCRF. Software can then compare the character containing the address mark to the user-defined address of the receiver. If they are the same, the receiver remains awake and processes the characters that follow. If they are not the same, software can set the RWU bit and put the receiver back into the standby state.
- Idle input line condition — When the WAKE bit is clear, an idle character on the RxD pin wakes the receiver from the standby state by clearing the RWU bit. The idle character that wakes the receiver does not set the receiver idle bit, IDLE, or the SCI receiver full bit, SCRF. The idle line type bit, ILTY, determines whether the receiver begins counting logic 1s as idle character bits after the start bit or after the stop bit.

NOTE

Clearing the WAKE bit after the RxD pin has been idle may cause the receiver to wake up immediately.

12.5.3.7 Receiver Interrupts

These sources can generate CPU interrupt requests from the SCI receiver:

- SCI receiver full (SCRF) — The SCRF bit in SCS1 indicates that the receive shift register has transferred a character to the SCDR. SCRF can generate a receiver interrupt request. Setting the SCI receive interrupt enable bit, SCRIE, in SCC2 enables the SCRF bit to generate receiver CPU interrupts.
- Idle input (IDLE) — The IDLE bit in SCS1 indicates that 10 or 11 consecutive logic 1s shifted in from the RxD pin. The idle line interrupt enable bit, ILIE, in SCC2 enables the IDLE bit to generate CPU interrupt requests.

12.5.3.8 Error Interrupts

These receiver error flags in SCS1 can generate CPU interrupt requests:

- Receiver overrun (OR) — The OR bit indicates that the receive shift register shifted in a new character before the previous character was read from the SCDR. The previous character remains in the SCDR, and the new character is lost. The overrun interrupt enable bit, ORIE, in SCC3 enables OR to generate SCI error CPU interrupt requests.
- Noise flag (NF) — The NF bit is set when the SCI detects noise on incoming data or break characters, including start, data, and stop bits. The noise error interrupt enable bit, NEIE, in SCC3 enables NF to generate SCI error CPU interrupt requests.
- Framing error (FE) — The FE bit in SCS1 is set when a logic 0 occurs where the receiver expects a stop bit. The framing error interrupt enable bit, FEIE, in SCC3 enables FE to generate SCI error CPU interrupt requests.

- Parity error (PE) — The PE bit in SCS1 is set when the SCI detects a parity error in incoming data. The parity error interrupt enable bit, PEIE, in SCC3 enables PE to generate SCI error CPU interrupt requests.

12.6 Wait Mode

The SCI module remains active after the execution of a WAIT instruction. In wait mode the SCI module registers are not accessible by the CPU. Any enabled CPU interrupt request from the SCI module can bring the MCU out of wait mode.

If SCI module functions are not required during wait mode, reduce power consumption by disabling the module before executing the WAIT instruction.

12.7 SCI During Break Module Interrupts

The system integration module (SIM) controls whether status bits in other modules can be cleared during interrupts generated by the break module. The BCFE bit in the SIM break flag control register (SBFCR) enables software to clear status bits during the break state.

To allow software to clear status bits during a break interrupt, write a logic 1 to the BCFE bit. If a status bit is cleared during the break state, it remains cleared when the MCU exits the break state.

To protect status bits during the break state, write a logic 0 to the BCFE bit. With BCFE at logic 0 (its default state), software can read and write I/O registers during the break state without affecting status bits. Some status bits have a two-step read/write clearing procedure. If software does the first step on such a bit before the break, the bit cannot change during the break state as long as BCFE is at logic 0. After the break, doing the second step clears the status bit.

12.8 I/O Signals

The two IrSCI input/output (I/O) pins are:

- TxD — Transmit data
- RxD — Receive data

12.8.1 TxD (Transmit Data)

This pin transmits SCI (standard or infrared) data. It will idle high in either mode and is high impedance anytime the transmitter is disabled.

12.8.2 RxD (Receive Data)

This pin receives SCI (standard or infrared) data. An idle line is detected as a line high. This input is ignored when the receiver is disabled and should be terminated to a known voltage.

A summary of the I/O pin considerations is given in [Table 12-4](#).

Table 12-4. SCI Standard and Infrared Pin Functions

| SCIRCR [IREN] | SCCR1 [ENSCI] | SCCR2 [TE] | SCCR2 [RE] | TxD pin | RxD pin |
|---------------|---------------|------------|------------|-----------------------|-------------------------------------|
| 0 | 1 | 0 | 0 | *Hi-Z | Input ignored, terminate externally |
| 0 | 1 | 0 | 1 | *Hi-Z | Input sampled, pin should idle high |
| 0 | 1 | 1 | 0 | Output SCI, idle high | Input ignored, terminate externally |
| 0 | 1 | 1 | 1 | Output SCI, idle high | Input sampled, pin should idle high |
| 1 | 1 | 0 | 0 | *Hi-Z | Input ignored, terminate externally |
| 1 | 1 | 0 | 1 | *Hi-Z | Input sampled, pin should idle high |
| 1 | 1 | 1 | 0 | Output IR, idle high | Input ignored, terminate externally |
| 1 | 1 | 1 | 1 | Output IR, idle high | Input sampled, pin should idle high |
| X | 0 | X | X | Hi-Z | Input ignored, terminate externally |

* After completion of transmission in progress

12.9 I/O Registers

These I/O registers control and monitor SCI operation:

- SCI control register 1 (SCC1)
- SCI control register 2 (SCC2)
- SCI control register 3 (SCC3)
- SCI status register 1 (SCS1)
- SCI status register 2 (SCS2)
- SCI data register (SCDR)
- SCI baud rate register (SCBR)
- SCI infrared control register (SCIRCR)

12.9.1 SCI Control Register 1

SCI control register 1:

- Enables loop mode operation
- Enables the SCI
- Controls output polarity
- Controls character length
- Controls SCI wakeup method
- Controls idle character detection
- Enables parity function
- Controls parity type

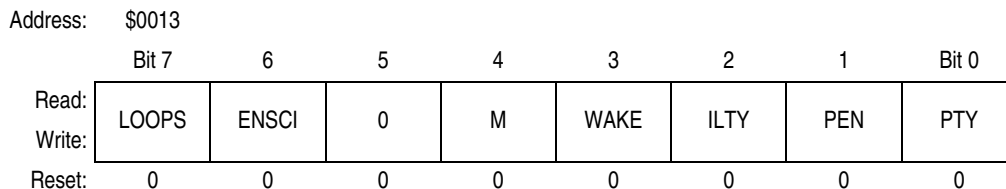

Figure 12-11. SCI Control Register 1 (SCC1)

LOOPS — Loop mode select bit

This bit enables loop mode operation for the SCI only. In loop mode the RxD pin is disconnected from the SCI, and the transmitter output goes into the receiver input. Both the transmitter and the receiver must be enabled to use loop mode. This bit does not affect the infrared encoder/decoder.

- 1 = Loop mode enabled
- 0 = Normal operation enabled

ENSCI — Enable SCI bit

This bit enables the SCI and the SCI baud rate generator. Clearing ENSCI sets the SCTE and TC bits in SCI status register 1 and disables transmitter interrupts.

- 1 = SCI enabled
- 0 = SCI disabled

M — Mode (character length) bit

This bit determines whether SCI characters are eight or nine bits long. (See [Table 12-5](#).) The ninth bit can serve as an extra stop bit, as a receiver wakeup signal, or as a parity bit.

- 1 = 9-bit SCI characters
- 0 = 8-bit SCI characters

WAKE — Wakeup condition bit

This bit determines which condition wakes up the SCI: a logic 1 (address mark) in the most significant bit position of a received character or an idle condition on the RxD pin.

- 1 = Address mark wakeup
- 0 = Idle line wakeup

ILTY — Idle line type bit

This bit determines when the SCI starts counting logic 1s as idle character bits. The counting begins either after the start bit or after the stop bit. If the count begins after the start bit, then a string of logic 1s preceding the stop bit may cause false recognition of an idle character. Beginning the count after the stop bit avoids false idle character recognition, but requires properly synchronized transmissions.

- 1 = Idle character bit count begins after stop bit
- 0 = Idle character bit count begins after start bit

PEN — Parity enable bit

This bit enables the SCI parity function. (See [Table 12-5](#).) When enabled, the parity function inserts a parity bit in the most significant bit position. (See [Figure 12-5](#).)

- 1 = Parity function enabled
- 0 = Parity function disabled

PTY — Parity bit

This bit determines whether the SCI generates and checks for odd parity or even parity.

(See [Table 12-5](#).)

- 1 = Odd parity
- 0 = Even parity

NOTE

Changing the PTY bit in the middle of a transmission or reception can generate a parity error.

Table 12-5. Character Format Selection

| Control bits | | Character format | | | | |
|--------------|---------|------------------|-----------|--------|-----------|------------------|
| M | PEN:PTY | Start bits | Data bits | Parity | Stop bits | Character length |
| 0 | 0X | 1 | 8 | None | 1 | 10 bits |
| 1 | 0X | 1 | 9 | None | 1 | 11 bits |
| 0 | 10 | 1 | 7 | Even | 1 | 10 bits |
| 0 | 11 | 1 | 7 | Odd | 1 | 10 bits |
| 1 | 10 | 1 | 8 | Even | 1 | 11 bits |
| 1 | 11 | 1 | 8 | Odd | 1 | 11 bits |

12.9.2 SCI Control Register 2

SCI control register 2:

- Enables the following CPU interrupt requests:
 - Enables the SCTE bit to generate transmitter interrupt requests
 - Enables the TC bit to generate transmitter interrupt requests
 - Enables the SCRF bit to generate receiver interrupt requests
 - Enables the IDLE bit to generate receiver CPU interrupt requests
- Enables the transmitter
- Enables the receiver
- Enables SCI wakeup
- Transmits SCI break characters

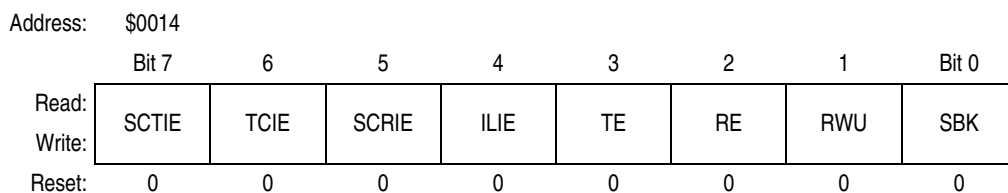

Figure 12-12. SCI Control Register 2 (SCC2)

SCTIE — SCI transmit interrupt enable bit

This bit enables the SCTE bit to generate SCI transmitter interrupt requests. Setting the SCTIE bit and clearing the DMA transfer enable bit, DMATE, in SCC3 enables the SCTE bit to generate CPU interrupt requests.

- 1 = SCTE enabled to generate CPU interrupt if DMATE is cleared
- 0 = SCTE not enabled to generate interrupt requests

TCIE — Transmission complete interrupt enable bit

This bit enables the TC bit to generate SCI transmitter CPU interrupt requests.

- 1 = TC enabled to generate CPU interrupt requests
- 0 = TC not enabled to generate CPU interrupt requests

SCRIE — SCI receive interrupt enable bit

This read/write bit enables the SCRF bit to generate SCI receiver CPU interrupt requests or SCI receiver DMA service requests. Setting the SCRIE bit and clearing the DMA receive enable bit, DMARE, in SCC3 enables the SCRF bit to generate CPU interrupt requests.

- 1 = SCRF enabled to generate interrupt requests if DMATE is cleared
- 0 = SCRF not enabled to generate interrupt requests

ILIE — Idle line interrupt enable bit

This read/write bit enables the IDLE bit to generate SCI receiver CPU interrupt requests.

- 1 = IDLE enabled to generate CPU interrupt requests
- 0 = IDLE not enabled to generate CPU interrupt requests

TE — Transmitter enable bit

Setting this read/write bit begins the transmission by sending a preamble of 10 or 11 logic 1s from the transmit shift register to the TxD pin. If software clears the TE bit, the transmitter completes any transmission in progress before the TxD returns to the high impedance state. Clearing and then setting TE during a transmission queues an idle character to be sent after the character currently being transmitted.

- 1 = Transmitter enabled
- 0 = Transmitter disabled

NOTE

Writing to the TE bit is not allowed when the enable SCI bit (ENSCI) is clear. ENSCI is in SCI control register 1.

RE — Receiver enable bit

Setting this bit enables the receiver. Clearing the RE bit disables the receiver but does not affect receiver interrupt flag bits.

- 1 = Receiver enabled
- 0 = Receiver disabled

NOTE

Writing to the RE bit is not allowed when the enable SCI bit (ENSCI) is clear. ENSCI is in SCI control register 1.

RWU — Receiver wakeup bit

This bit puts the receiver in a standby state during which receiver interrupts are disabled. The WAKE bit in SCC1 determines whether an idle input or an address mark brings the receiver out of the standby state and clears the RWU bit.

- 1 = Standby state
- 0 = Normal operation

SBK — Send break bit

Setting and then clearing this read/write bit transmits a break character followed by a logic 1. The logic 1 after the break character guarantees recognition of a valid start bit. If SBK remains set, the transmitter continuously transmits break characters with no logic 1s between them.

- 1 = Transmit break characters
- 0 = No break characters being transmitted

NOTE

Do not toggle the SBK bit immediately after setting the SCTE bit. Toggling SBK too early causes the SCI to send a break character instead of a preamble.

12.9.3 SCI Control Register 3

SCI control register 3:

- Stores the ninth SCI data bit received and the ninth SCI data bit to be transmitted
- Enables these interrupts:
 - Receiver overrun interrupts
 - Noise error interrupts
 - Framing error interrupts
 - Parity error interrupts

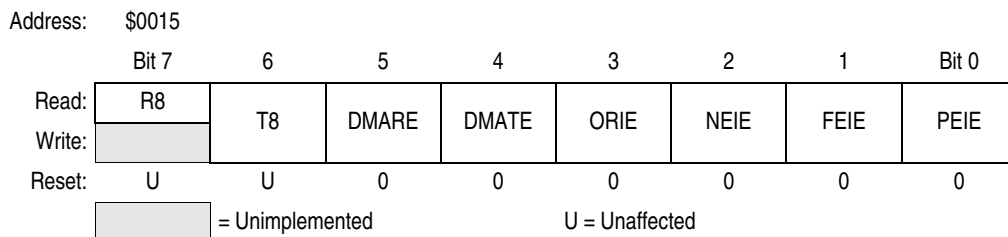

Figure 12-13. SCI Control Register 3 (SCC3)

R8 — Received bit 8

When the SCI is receiving 9-bit characters, R8 is the read-only ninth bit (bit 8) of the received character. R8 is received at the same time that the SCDR receives the other eight bits. When the SCI is receiving 8-bit characters, R8 is a copy of the eighth bit (bit 7).

T8 — Transmitted bit 8

When the SCI is transmitting 9-bit characters, T8 is the read/write ninth bit (bit 8) of the transmitted character. T8 is loaded into the transmit shift register at the same time that the SCDR is loaded into the transmit shift register.

DMARE — DMA receive enable bit

This bit enables the DMA to service SCI receiver DMA service requests generated by the SCRF bit. (See [12.9.4 SCI Status Register 1.](#)) Setting the DMARE bit disables SCI receiver CPU interrupt requests.

- 1 = DMA enabled to service SCI receiver DMA service requests generated by the SCRF bit (SCI receiver CPU interrupt requests disabled)
- 0 = DMA not enabled to service SCI receiver DMA service requests generated by the SCRF bit (SCI receiver CPU interrupt requests enabled)

CAUTION

There is no DMA on this device. This bit should be cleared.

DMATE — DMA transfer enable bit

This bit enables SCI transmitter empty (SCTE) DMA service requests. (See [12.9.4 SCI Status Register 1](#).) Setting the DMATE bit disables SCTE CPU interrupt requests.

- 1 = SCTE DMA service requests enabled (SCTE CPU interrupt requests disabled)
- 0 = SCTE DMA service requests disabled (SCTE CPU interrupt requests enabled)

CAUTION

There is no DMA on this device. This bit should be cleared.

ORIE — Receiver overrun interrupt enable bit

This bit enables SCI error CPU interrupt requests generated by the receiver overrun bit, OR.

- 1 = SCI error CPU interrupt requests from OR bit enabled
- 0 = SCI error CPU interrupt requests from OR bit disabled

NEIE — Receiver noise error interrupt enable bit

This bit enables SCI error CPU interrupt requests generated by the noise error bit, NE.

- 1 = SCI error CPU interrupt requests from NE bit enabled
- 0 = SCI error CPU interrupt requests from NE bit disabled

FEIE — Receiver framing error interrupt enable bit

This bit enables SCI error CPU interrupt requests generated by the framing error bit, FE.

- 1 = SCI error CPU interrupt requests from FE bit enabled
- 0 = SCI error CPU interrupt requests from FE bit disabled

PEIE — Receiver parity error interrupt enable bit

This bit enables SCI receiver CPU interrupt requests generated by the parity error bit, PE. (See [12.9.4 SCI Status Register 1](#).)

- 1 = SCI error CPU interrupt requests from PE bit enabled
- 0 = SCI error CPU interrupt requests from PE bit disabled

12.9.4 SCI Status Register 1

SCI status register 1 contains flags to signal these conditions:

- Transfer of SCDR data to transmit shift register complete
- Transmission complete
- Transfer of receive shift register data to SCDR complete
- Receiver input idle
- Receiver overrun
- Noisy data
- Framing error
- Parity error

Address: \$0016

| | Bit 7 | 6 | 5 | 4 | 3 | 2 | 1 | Bit 0 |
|--------|-------|----|-------|------|----|----|----|-------|
| Read: | SCTE | TC | SCRIF | IDLE | OR | NF | FE | PE |
| Write: | | | | | | | | |
| Reset: | 1 | 1 | 0 | 0 | 0 | 0 | 0 | 0 |

= Unimplemented

Figure 12-14. SCI Status Register 1 (SCS1)

SCTE — SCI transmitter empty bit

This clearable, read-only bit is set when the SCDR transfers a character to the transmit shift register. SCTE can generate an SCI transmitter interrupt request. When the SCTIE bit in SCC2 is set and the DMATE bit in SCC3 is clear, SCTE generates an SCI transmitter CPU interrupt request. Clear the SCTE bit by reading SCS1 with SCTE set and then writing to SCDR.

- 1 = SCDR data transferred to transmit shift register
- 0 = SCDR data not transferred to transmit shift register

TC — Transmission complete bit

This read-only bit is set when the SCTE bit is set, and no data, preamble, or break character is being transmitted. TC generates an SCI transmitter CPU interrupt request if the TCIE bit in SCC2 is also set. TC is automatically cleared when data, preamble, or break is queued and ready to be sent. There may be up to 1.5 transmitter clocks of latency between queuing data, preamble, and break and the transmission actually starting.

- 1 = No transmission in progress
- 0 = Transmission in progress

SCRF — SCI receiver full bit

This clearable, read-only bit is set when the data in the receive shift register transfers to the SCI data register. SCRF can generate an SCI receiver interrupt request. When the SCRIE bit in SCC2 is set and the DMARE bit in SCC3 is clear, SCRF generates a CPU interrupt request. Clear the SCRF bit by reading SCS1 with SCRF set and then reading the SCDR.

- 1 = Received data available in SCDR
- 0 = Data not available in SCDR

IDLE — Receiver idle bit

This clearable, read-only bit is set when 10 or 11 consecutive logic 1s appear on the receiver input. IDLE generates an SCI error CPU interrupt request if the ILIE bit in SCC2 is also set and the DMARE bit in SCC3 is clear. Clear the IDLE bit by reading SCS1 with IDLE set and then reading the SCDR. After the receiver is enabled, it must receive a valid character that sets the SCRF bit before an idle condition can set the IDLE bit. Also, after the IDLE bit has been cleared, a valid character must again set the SCRF bit before an idle condition can set the IDLE bit.

- 1 = Receiver input idle
- 0 = Receiver input active (or idle since the IDLE bit was cleared)

OR — Receiver overrun bit

This clearable, read-only bit is set when software fails to read the SCDR before the receive shift register receives the next character. The OR bit generates an SCI error CPU interrupt request if the ORIE bit in SCC3 is also set. The data in the shift register is lost, but the data already in the SCDR is not affected. Clear the OR bit by reading SCS1 with OR set and then reading the SCDR.

- 1 = Receive shift register full and SCRF = 1
- 0 = No receiver overrun

Software latency may allow an overrun to occur between reads of SCS1 and SCDR in the flag-clearing sequence. [Figure 12-15](#) shows the normal flag-clearing sequence and an example of an overrun caused by a delayed flag-clearing sequence. The delayed read of SCDR does not clear the OR bit because OR was not set when SCS1 was read. Byte 2 caused the overrun and is lost. The next flag-clearing sequence reads byte 3 in the SCDR instead of byte 2.

In applications that are subject to software latency or in which it is important to know which byte is lost due to an overrun, the flag-clearing routine can check the OR bit in a second read of SCS1 after reading the data register.

NF — Receiver noise flag bit

This clearable, read-only bit is set when the SCI detects noise on the RxD pin. NF generates an NF CPU interrupt request if the NEIE bit in SCC3 is also set. Clear the NF bit by reading SCS1 and then reading the SCDR.

- 1 = Noise detected
- 0 = No noise detected

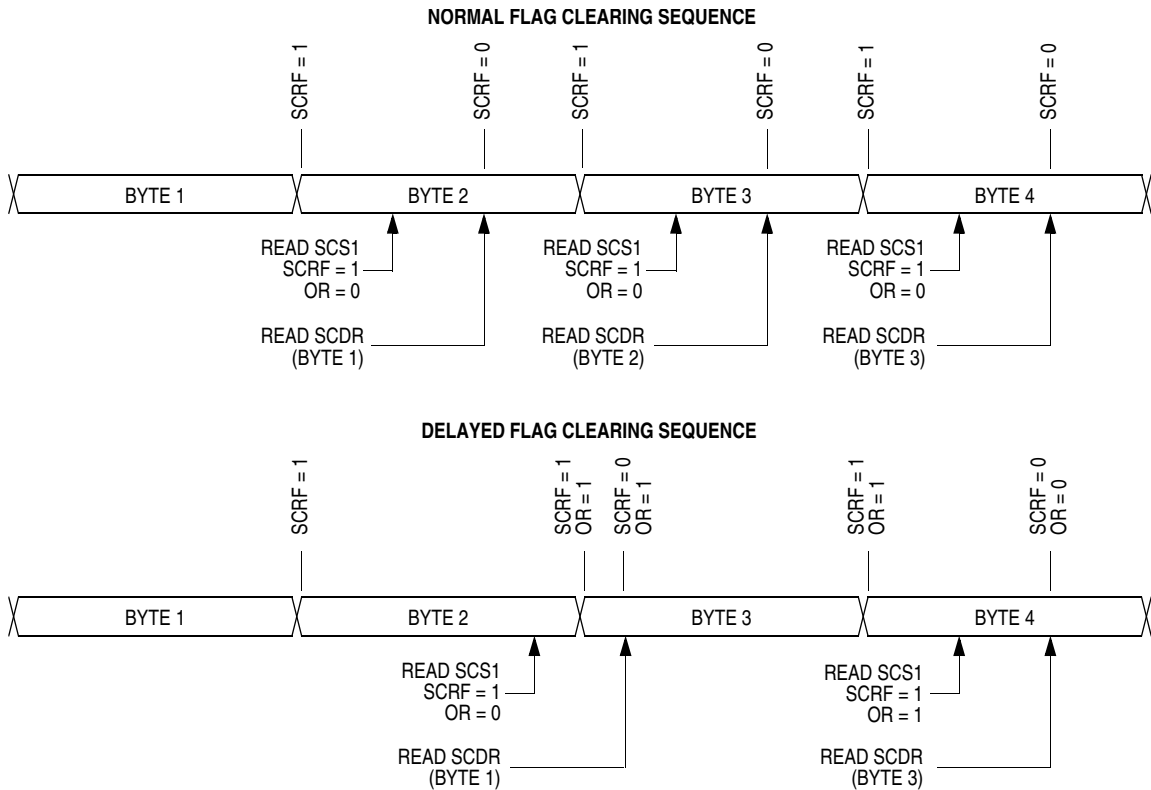

Figure 12-15. Flag Clearing Sequence

FE — Receiver framing error bit

This clearable, read-only bit is set when a logic 0 is accepted as the stop bit. FE generates an SCI error CPU interrupt request if the FEIE bit in SCC3 also is set. Clear the FE bit by reading SCS1 with FE set and then reading the SCDR.

- 1 = Framing error detected
- 0 = No framing error detected

PE — Receiver parity error bit

This clearable, read-only bit is set when the SCI detects a parity error in incoming data. PE generates a PE CPU interrupt request if the PEIE bit in SCC3 is also set. Clear the PE bit by reading SCS1 with PE set and then reading the SCDR.

- 1 = Parity error detected
- 0 = No parity error detected

12.9.5 SCI Status Register 2

SCI status register 2 contains flags to signal the following conditions:

- Break character detected
- Incoming data

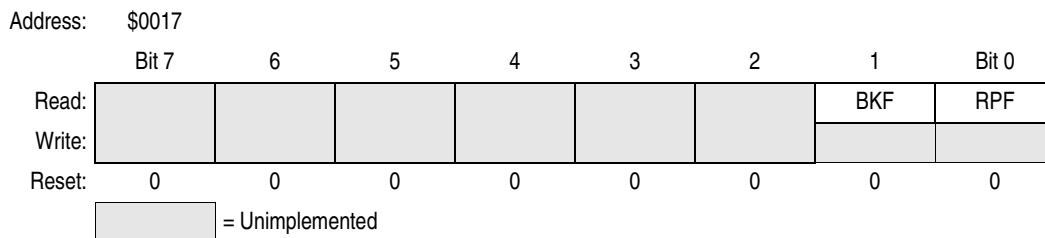

Figure 12-16. SCI Status Register 2 (SCS2)

BKF — Break flag bit

This clearable, read-only bit is set when the SCI detects a break character on the RxD pin. In SCS1, the FE and SCRFB bits are also set. In 9-bit character transmissions, the R8 bit in SCC3 is cleared. BKF does not generate an interrupt request. Clear BKF by reading SCS2 with BKF set and then reading the SCDR. Once cleared, BKF can become set again only after logic 1s again appear on the RxD pin followed by another break character.

- 1 = Break character detected
- 0 = No break character detected

RPF — Reception-in-progress flag bit

This bit is set when the receiver detects a logic 0 during the RT1 time period of the start bit search. RPF does not generate an interrupt request. RPF is reset after the receiver detects false start bits (usually from noise or a baud rate mismatch, or when the receiver detects an idle character. Polling RPF before disabling the SCI module or entering stop mode can show whether a reception is in progress.

- 1 = Reception in progress
- 0 = No reception in progress

12.9.6 SCI Data Register

The SCI data register is the buffer between the internal data bus and the receive and transmit shift registers. Reset has no effect on data in the SCI data register.

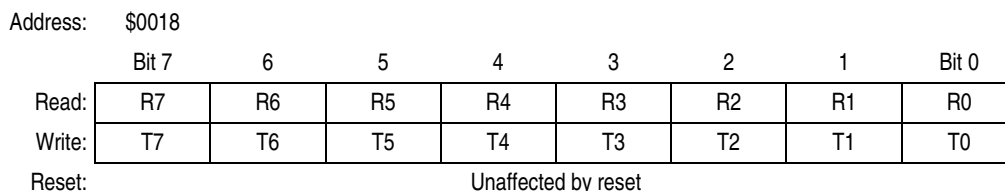

Figure 12-17. SCI Data Register (SCDR)

R7/T7–R0/T0 — Receive/transmit data bits

Reading the SCDR accesses the read-only received data bits, R7–R0. Writing to the SCDR writes the data to be transmitted, T7–T0.

12.9.7 SCI Baud Rate Register

The baud rate register selects the baud rate for both the receiver and the transmitter.

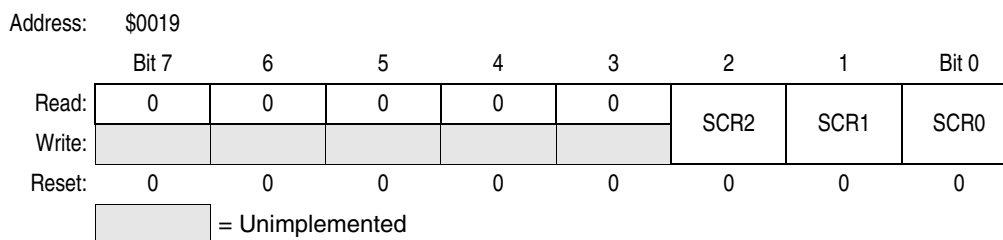

Figure 12-18. SCI Baud Rate Register (SCBR)

SCR2–SCR0 — SCI baud rate select bits

These read/write bits select the SCI baud rate divisor as shown in [Table 12-6](#).

CAUTION

For proper SCI function, the bus clock (CGMOUT ÷ 2) MUST be programmed to at least 32 times that of SCI baud rate.

Table 12-6. SCI Baud Rate Selection

| SCR2:1:0 | Baud rate divisor (BD) |
|----------|------------------------|
| 000 | 1 |
| 001 | 2 |
| 010 | 4 |
| 011 | 8 |
| 100 | 16 |
| 101 | 32 |
| 110 | 64 |
| 111 | 128 |

Use the following formula to calculate the SCI baud rate:

$$\text{Baud rate} = \frac{\text{CGMOUT} \div 2}{16 \times \text{BD}}$$

where:

CGMOUT ÷ 2 = bus frequency

BD = baud rate divisor

Table 12-7 shows the SCI baud rates that can be generated with a 307.2-kHz input clock.

Table 12-7. SCI Baud Rate Selection Examples

| SCR2:1:0 | Baud rate divisor (BD) | Baud rate (CGMOUT ÷ 2 = 307.2 kHz) |
|----------|------------------------|------------------------------------|
| 000 | 1 | 19,200 |
| 001 | 2 | 9600 |
| 010 | 4 | 4800 |
| 011 | 8 | 2400 |
| 100 | 16 | 1200 |
| 101 | 32 | 600 |
| 110 | 64 | 300 |
| 111 | 128 | 150 |

CAUTION

Do not select 1/32 transmission (TNP1:0 = 11/10) for the highest baud rate (SCR2:0 = 000). A 32X clock is not available under these conditions.

12.9.8 SCI Infrared Control Register

The infrared control register is a read/write register containing the control bits for the infrared submodule. The IREN bit has to be set for any of the other bits can operate. The configuration of this register in reset is shown in Figure 12-19.

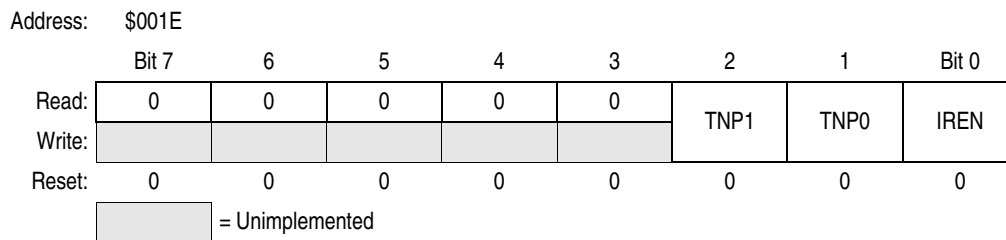

Figure 12-19. SCI Infrared Control Register (SCIRCR)

TNP1 and TNP0 — Transmitter narrow pulse bits

These bits enable whether the SCI transmits a 1/16, 3/16, or 1/32 narrow pulse.

- 11 = SCI transmits a 1/32 narrow pulse.
- 10 = SCI transmits a 1/32 narrow pulse.
- 01 = SCI transmits a 1/16 narrow pulse.
- 00 = SCI transmits a 3/16 narrow pulse.

IREN — IR enable bit

This bit enables the entire infrared submodule. When this bit is clear, the IR is disabled.

- 1 = IR enabled
- 0 = IR disabled



Chapter 13

Serial Peripheral Interface Module (SPI)

13.1 Introduction

This section describes the serial peripheral interface (SPI) module which allows full-duplex, synchronous, serial communications with peripheral devices.

NOTE

References to DMA and associated functions are only valid if the MCU has a DMA module. This MCU does not have the DMA function. Any DMA-related register bits should be left in their reset state for normal MCU operation.

13.2 Features

Features of the SPI module include:

- Full-duplex operation
- Master and slave modes
- Double-buffered operation with separate transmit and receive registers
- Four master mode frequencies (maximum = bus frequency \div 2)
- Maximum slave mode frequency = bus frequency
- Clock ground for reduced radio frequency (RF) interference
- Serial clock with programmable polarity and phase
- Two separately enabled interrupts:
 - SPRF (SPI receiver full)
 - SPTE (SPI transmitter empty)
- Mode fault error flag with CPU interrupt capability
- Overflow error flag with CPU interrupt capability
- Programmable wired-OR mode
- I²C (inter-integrated circuit) compatibility

13.3 Functional Description

Figure 13-1 shows the locations and contents of the SPI input/output (I/O) registers and Figure 13-2 shows the structure of the SPI module.

| Addr. | Register Name | Bit 7 | 6 | 5 | 4 | 3 | 2 | 1 | Bit 0 | |
|--------|---|--------|---------------------------|-------|--------|------|------|--------|-------|-------|
| \$000D | SPI Control Register (SPCR) | Read: | SPRIE | DMAS | SPMSTR | CPOL | CPHA | SPWOM | SPE | SPTIE |
| | | Write: | | | | | | | | |
| | | Reset: | 0 | 0 | 1 | 0 | 1 | 0 | 0 | 0 |
| \$000E | SPI Status and Control Register (SPSCR) | Read: | SPRF | ERRIE | OVRF | MODF | SPTE | MODFEN | SPR1 | SPR0 |
| | | Write: | | | | | | | | |
| | | Reset: | 0 | 0 | 0 | 0 | 1 | 0 | 0 | 0 |
| \$000F | SPI Data Register (SPDR) | Read: | R7 | R6 | R5 | R4 | R3 | R2 | R1 | R0 |
| | | Write: | T7 | T6 | T5 | T4 | T3 | T2 | T1 | T0 |
| | | Reset: | Indeterminate after reset | | | | | | | |

= Unimplemented

Figure 13-1. SPI I/O Register Summary

The SPI module allows full-duplex, synchronous, serial communication among the MCU and peripheral devices, including other MCUs. Software can poll the SPI status flags or SPI operation can be interrupt-driven.

The following paragraphs describe the operation of the SPI module.

13.3.1 Master Mode

The SPI operates in master mode when the SPI master bit, SPMSTR, is set.

NOTE

Configure the SPI modules as master or slave before enabling them. Enable the master SPI before enabling the slave SPI. Disable the slave SPI before disabling the master SPI. (See 13.13.1 SPI Control Register.)

Only a master SPI module can initiate transmissions. Software begins the transmission from a master SPI module by writing to the transmit data register. If the shift register is empty, the byte immediately transfers to the shift register, setting the SPI transmitter empty bit, SPTE. The byte begins shifting out on the MOSI pin under the control of the serial clock. (See Figure 13-3.)

The SPR1 and SPR0 bits control the baud rate generator and determine the speed of the shift register. (See 13.13.2 SPI Status and Control Register.) Through the SPSCCK pin, the baud rate generator of the master also controls the shift register of the slave peripheral.

As the byte shifts out on the MOSI pin of the master, another byte shifts in from the slave on the master’s MISO pin. The transmission ends when the receiver full bit, SPRF, becomes set. At the same time that SPRF becomes set, the byte from the slave transfers to the receive data register. In normal operation, SPRF signals the end of a transmission. Software clears SPRF by reading the SPI status and control register with SPRF set and then reading the SPI data register. Writing to the SPI data register clears the SPTE bit.

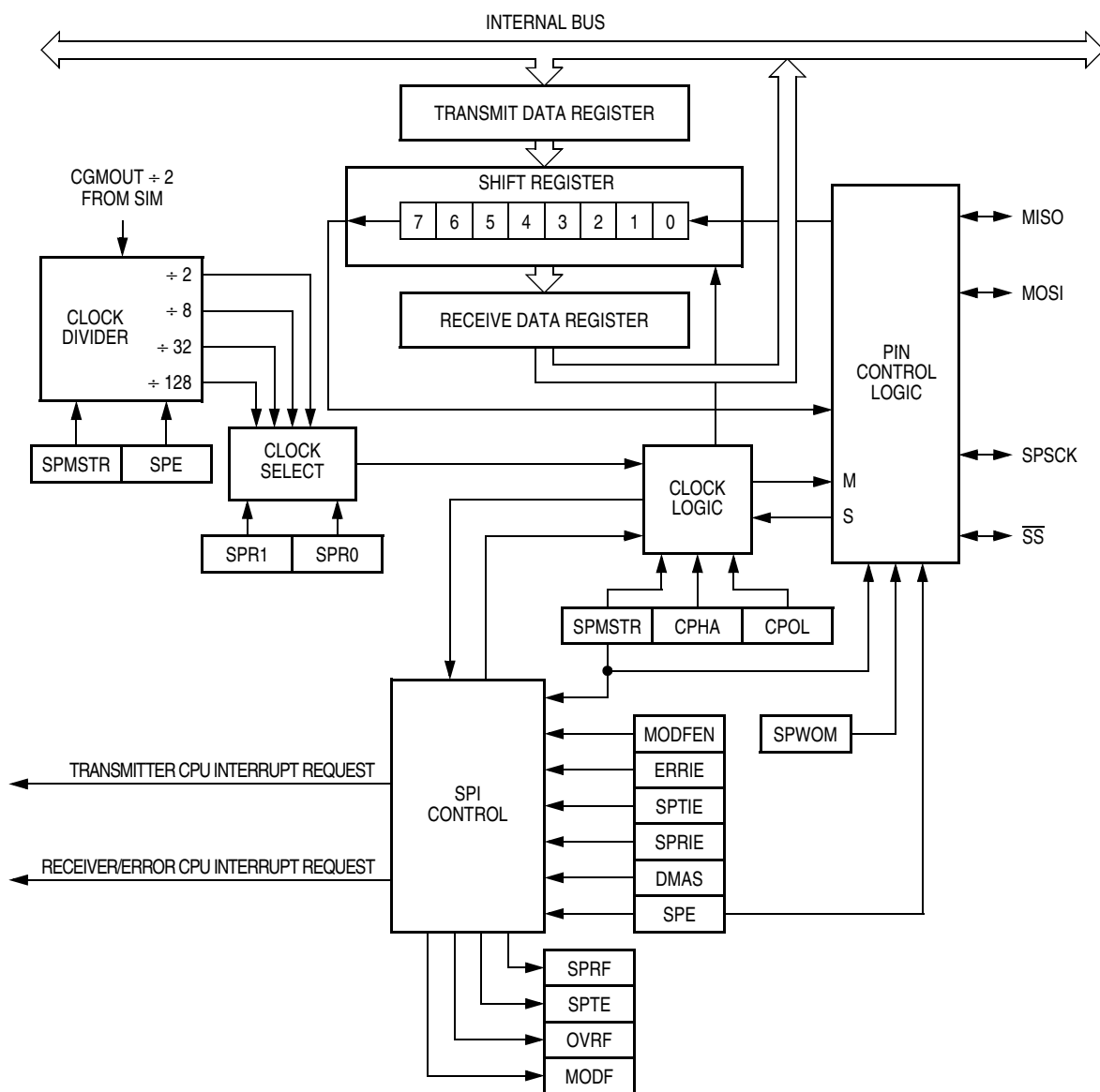

Figure 13-2. SPI Module Block Diagram

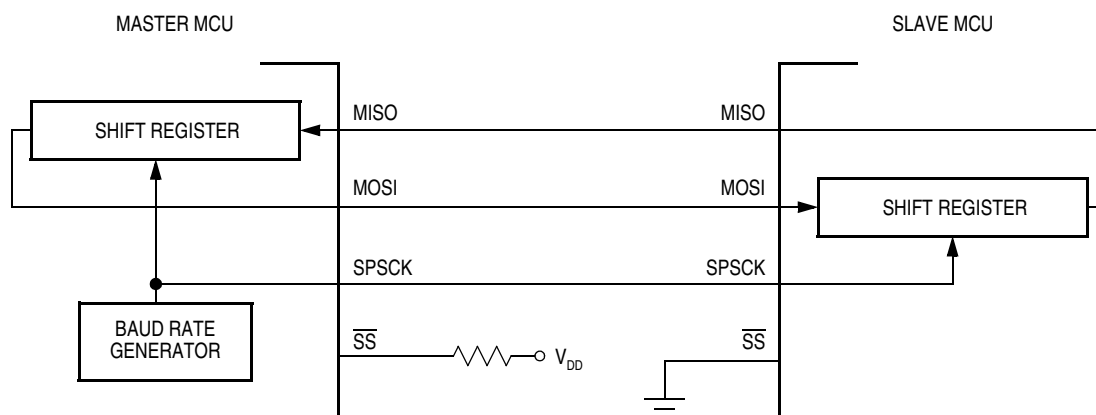

Figure 13-3. Full-Duplex Master-Slave Connections

13.4 Slave Mode

The SPI operates in slave mode when the SPMSTR bit is clear. In slave mode, the SPSCK pin is the input for the serial clock from the master MCU. Before a data transmission occurs, the \overline{SS} pin of the slave SPI must be at logic 0. \overline{SS} must remain low until the transmission is complete. (See [13.7.2 Mode Fault Error.](#))

In a slave SPI module, data enters the shift register under the control of the serial clock from the master SPI module. After a byte enters the shift register of a slave SPI, it transfers to the receive data register, and the SPRF bit is set. To prevent an overflow condition, slave software then must read the receive data register before another full byte enters the shift register.

The maximum frequency of the SPSCK for an SPI configured as a slave is the bus clock speed (which is twice as fast as the fastest master SPSCK clock that can be generated). The frequency of the SPSCK for an SPI configured as a slave does not have to correspond to any SPI baud rate. The baud rate only controls the speed of the SPSCK generated by an SPI configured as a master. Therefore, the frequency of the SPSCK for an SPI configured as a slave can be any frequency less than or equal to the bus speed.

When the master SPI starts a transmission, the data in the slave shift register begins shifting out on the MISO pin. The slave can load its shift register with a new byte for the next transmission by writing to its transmit data register. The slave must write to its transmit data register at least one bus cycle before the master starts the next transmission. Otherwise, the byte already in the slave shift register shifts out on the MISO pin. Data written to the slave shift register during a transmission remains in a buffer until the end of the transmission.

When the clock phase bit (CPHA) is set, the first edge of SPSCK starts a transmission. When CPHA is clear, the falling edge of \overline{SS} starts a transmission. (See [13.5 Transmission Formats.](#))

NOTE

SPSCK must be in the proper idle state before the slave is enabled to prevent SPSCK from appearing as a clock edge.

13.5 Transmission Formats

During an SPI transmission, data is simultaneously transmitted (shifted out serially) and received (shifted in serially). A serial clock synchronizes shifting and sampling on the two serial data lines. A slave select line allows selection of an individual slave SPI device; slave devices that are not selected do not interfere with SPI bus activities. On a master SPI device, the slave select line can be optionally used to indicate multiple-master bus contention.

13.5.1 Clock Phase and Polarity Controls

Software can select any of four combinations of serial clock (SPSCK) phase and polarity using two bits in the SPI control register (SPCR). The clock polarity is specified by the CPOL control bit, which selects an active high or low clock and has no significant effect on the transmission format.

The clock phase (CPHA) control bit selects one of two fundamentally different transmission formats. The clock phase and polarity should be identical for the master SPI device and the communicating slave device. In some cases, the phase and polarity are changed between transmissions to allow a master device to communicate with peripheral slaves having different requirements.

NOTE

Before writing to the CPOL bit or the CPHA bit, disable the SPI by clearing the SPI enable bit (SPE).

13.5.2 Transmission Format When CPHA = 0

Figure 13-4 shows an SPI transmission in which CPHA is logic 0. The figure should not be used as a replacement for data sheet parametric information. Two waveforms are shown for SPSCK: one for CPOL = 0 and another for CPOL = 1. The diagram may be interpreted as a master or slave timing diagram since the serial clock (SPSCK), master in/slave out (MISO), and master out/slave in (MOSI) pins are directly connected between the master and the slave. The MISO signal is the output from the slave, and the MOSI signal is the output from the master. The \overline{SS} line is the slave select input to the slave. The slave SPI drives its MISO output only when its slave select input (\overline{SS}) is at logic 0, so that only the selected slave drives to the master. The \overline{SS} pin of the master is not shown but is assumed to be inactive. The \overline{SS} pin of the master must be high or must be reconfigured as general-purpose I/O not affecting the SPI. (See 13.7.2 Mode Fault Error.) When CPHA = 0, the first SPSCK edge is the MSB capture strobe. Therefore the slave must begin driving its data before the first SPSCK edge, and a falling edge on the \overline{SS} pin is used to start the slave data transmission. The slave's \overline{SS} pin must be toggled back to high and then low again between each byte transmitted as shown in Figure 13-5.

NOTE

The \overline{SS} pin on this device cannot be configured as a general-purpose I/O.

When CPHA = 0 for a slave, the falling edge of \overline{SS} indicates the beginning of the transmission. This causes the SPI to leave its idle state and begin driving the MISO pin with the MSB of its data. Once the transmission begins, no new data is allowed into the shift register from the transmit data register. Therefore, the SPI data register of the slave must be loaded with transmit data before the falling edge of \overline{SS} . Any data written after the falling edge is stored in the transmit data register and transferred to the shift register after the current transmission.

Serial Peripheral Interface Module (SPI)

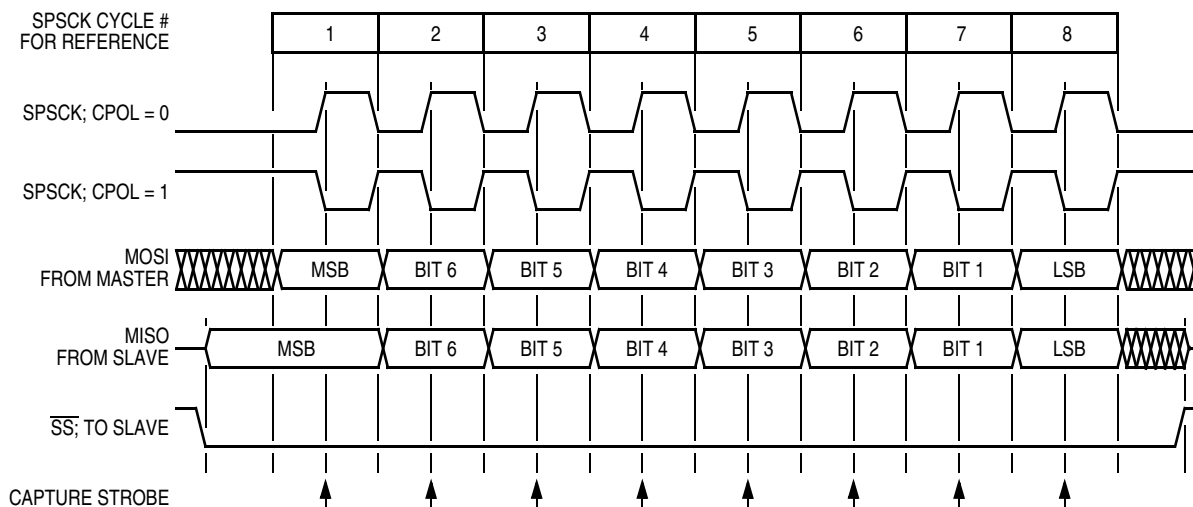

Figure 13-4. Transmission Format (CPHA = 0)

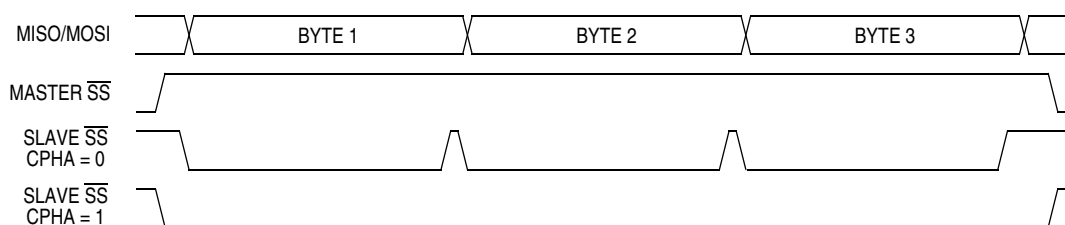

Figure 13-5. CPHA/SS Timing

13.5.3 Transmission Format When CPHA = 1

Figure 13-6 shows an SPI transmission in which CPHA is logic 1. The figure should not be used as a replacement for data sheet parametric information. Two waveforms are shown for SPSCK: one for CPOL = 0 and another for CPOL = 1. The diagram may be interpreted as a master or slave timing diagram since the serial clock (SPSCK), master in/slave out (MISO), and master out/slave in (MOSI) pins are directly connected between the master and the slave. The MISO signal is the output from the slave, and the MOSI signal is the output from the master. The \overline{SS} line is the slave select input to the slave. The slave SPI drives its MISO output only when its slave select input (\overline{SS}) is at logic 0, so that only the selected slave drives to the master. The \overline{SS} pin of the master is not shown but is assumed to be inactive. The \overline{SS} pin of the master must be high or must be reconfigured as general-purpose I/O not affecting the SPI. (See 13.7.2 Mode Fault Error.) When CPHA = 1, the master begins driving its MOSI pin on the first SPSCK edge. Therefore, the slave uses the first SPSCK edge as a start transmission signal. The \overline{SS} pin can remain low between transmissions. This format may be preferable in systems having only one master and only one slave driving the MISO data line.

NOTE

The \overline{SS} pin on this device cannot be configured as a general-purpose I/O.

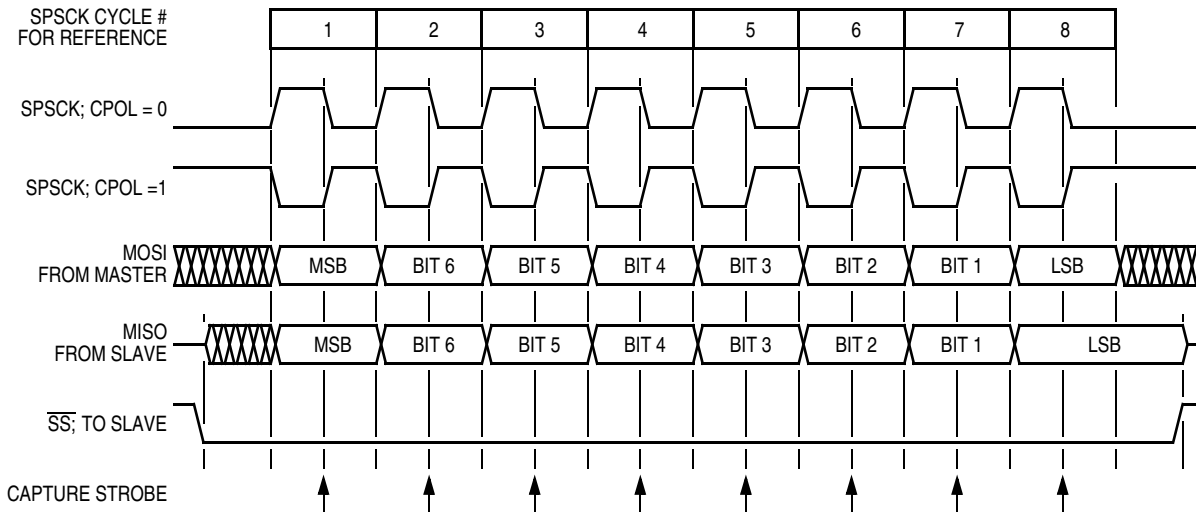

Figure 13-6. Transmission Format (CPHA = 1)

When CPHA = 1 for a slave, the first edge of the SPSCK indicates the beginning of the transmission. This causes the SPI to leave its idle state and begin driving the MISO pin with the MSB of its data. Once the transmission begins, no new data is allowed into the shift register from the transmit data register. Therefore, the SPI data register of the slave must be loaded with transmit data before the first edge of SPSCK. Any data written after the first edge is stored in the transmit data register and transferred to the shift register after the current transmission.

13.5.4 Transmission Initiation Latency

When the SPI is configured as a master (SPMSTR = 1), writing to the SPDR starts a transmission. CPHA has no effect on the delay to the start of the transmission, but it does affect the initial state of the SPSCK signal. When CPHA = 0, the SPSCK signal remains inactive for the first half of the first SPSCK cycle. When CPHA = 1, the first SPSCK cycle begins with an edge on the SPSCK line from its inactive to its active level. The SPI clock rate (selected by SPR1:SPR0) affects the delay from the write to SPDR and the start of the SPI transmission. (See [Figure 13-7](#).) The internal SPI clock in the master is a free-running derivative of the internal MCU clock. To conserve power, it is enabled only when both the SPE and SPMSTR bits are set. SPSCK edges occur halfway through the low time of the internal MCU clock. Since the SPI clock is free-running, it is uncertain where the write to the SPDR occurs relative to the slower SPSCK. This uncertainty causes the variation in the initiation delay shown in [Figure 13-7](#). This delay is no longer than a single SPI bit time. That is, the maximum delay is two MCU bus cycles for DIV2, eight MCU bus cycles for DIV8, 32 MCU bus cycles for DIV32, and 128 MCU bus cycles for DIV128.

Serial Peripheral Interface Module (SPI)

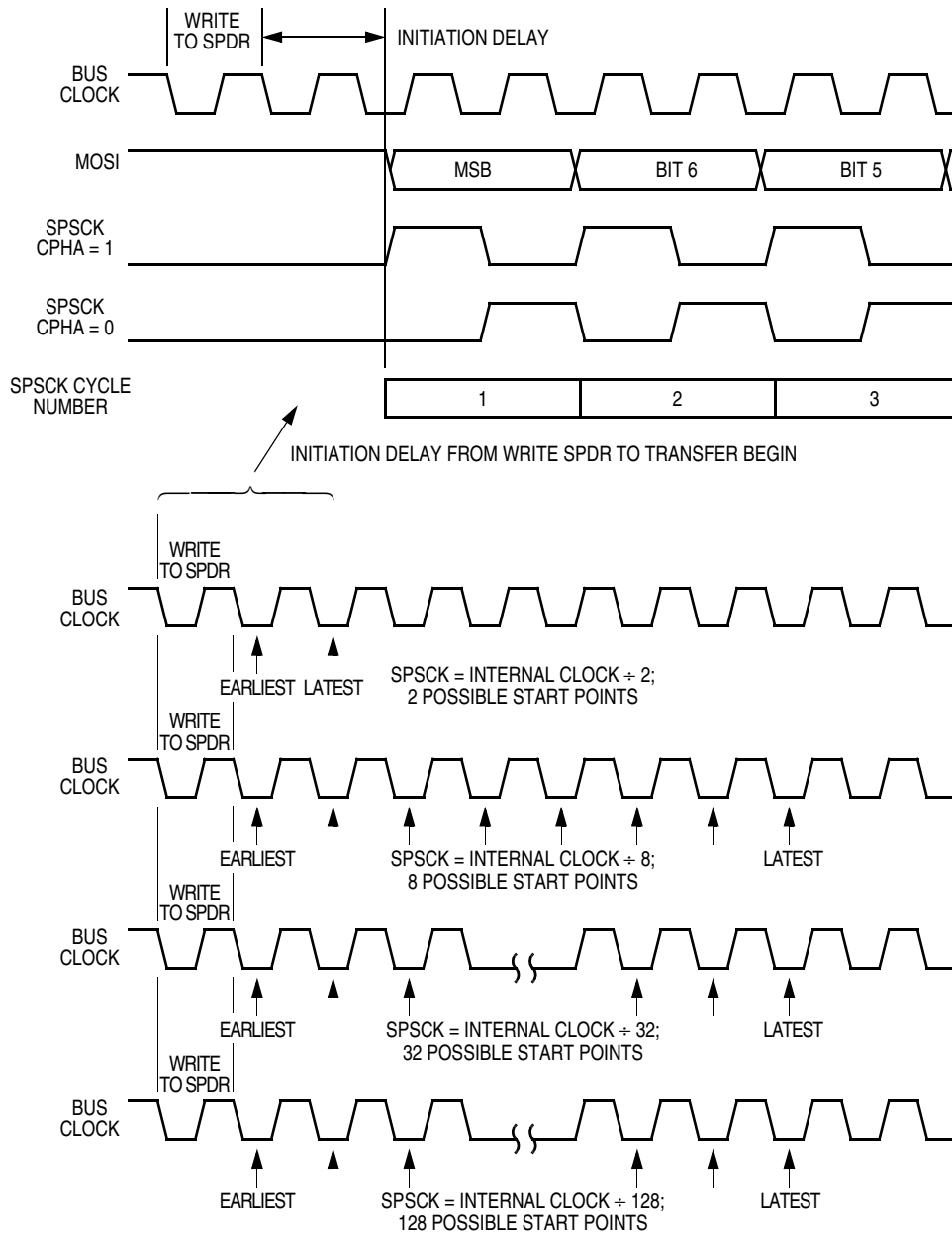

Figure 13-7. Transmission Start Delay (Master)

13.6 Queuing Transmission Data

The double-buffered transmit data register allows a data byte to be queued and transmitted. For an SPI configured as a master, a queued data byte is transmitted immediately after the previous transmission has completed. The SPI transmitter empty flag (SPTE) indicates when the transmit data buffer is ready to accept new data. Write to the transmit data register only when the SPTE bit is high. Figure 13-8 shows the timing associated with doing back-to-back transmissions with the SPI (SPSCK has CPHA: CPOL = 1:0).

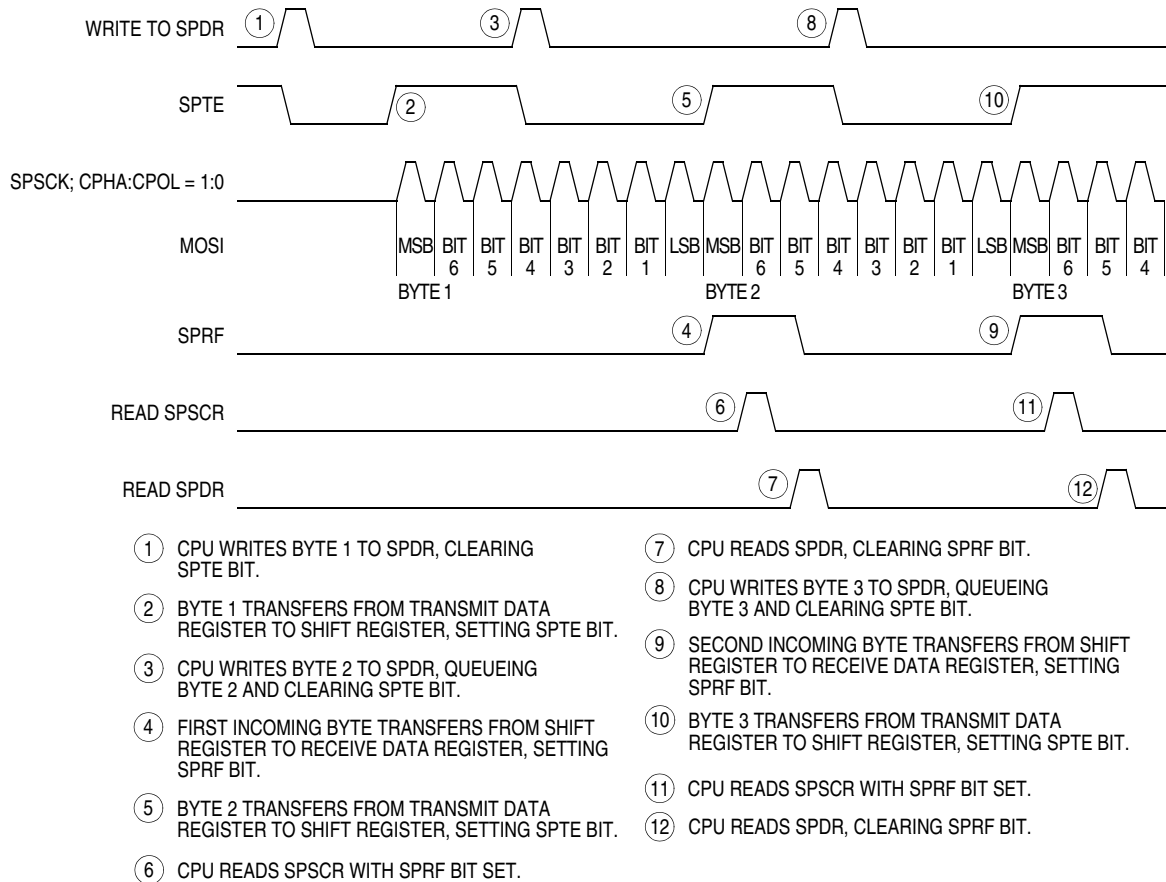

Figure 13-8. SPRF/SPTE CPU Interrupt Timing

The transmit data buffer allows back-to-back transmissions without the slave precisely timing its writes between transmissions as in a system with a single data buffer. Also, if no new data is written to the data buffer, the last value contained in the shift register is the next data word to be transmitted.

For an idle master or idle slave that has no data loaded into its transmit buffer, the SPTE is set again no more than two bus cycles after the transmit buffer empties into the shift register. This allows the user to queue up a 16-bit value to send. For an already active slave, the load of the shift register cannot occur until the transmission is completed. This implies that a back-to-back write to the transmit data register is not possible. The SPTE indicates when the next write can occur.

13.7 Error Conditions

These flags signal SPI error conditions:

- Overflow (OVRF) — Failing to read the SPI data register before the next full byte enters the shift register sets the OVRF bit. The new byte does not transfer to the receive data register, and the unread byte still can be read. OVRF is in the SPI status and control register.
- Mode fault error (MODF) — The MODF bit indicates that the voltage on the slave select pin (\overline{SS}) is inconsistent with the mode of the SPI. MODF is in the SPI status and control register.

13.7.1 Overflow Error

The overflow flag (OVRF) becomes set if the receive data register still has unread data from a previous transmission when the capture strobe of bit 1 of the next transmission occurs. The bit 1 capture strobe occurs in the middle of SPSCK cycle 7. (See [Figure 13-4](#) and [Figure 13-6](#).) If an overflow occurs, all data received after the overflow and before the OVRF bit is cleared does not transfer to the receive data register and does not set the SPI receiver full bit (SPRF). The unread data that transferred to the receive data register before the overflow occurred can still be read. Therefore, an overflow error always indicates the loss of data. Clear the overflow flag by reading the SPI status and control register and then reading the SPI data register.

OVRF generates a receiver/error CPU interrupt request if the error interrupt enable bit (ERRIE) is also set. The SPRF, MODF, and OVRF interrupts share the same CPU interrupt vector. It is not possible to enable MODF or OVRF individually to generate a receiver/error CPU interrupt request. However, leaving MODFEN low prevents MODF from being set.

If the CPU SPRF interrupt is enabled and the OVRF interrupt is not, watch for an overflow condition. [Figure 13-9](#) shows how it is possible to miss an overflow. The first part of [Figure 13-9](#) shows how it is possible to read the SPSCR and SPDR to clear the SPRF without problems. However, as illustrated by the second transmission example, the OVRF bit can be set in between the time that SPSCR and SPDR are read.

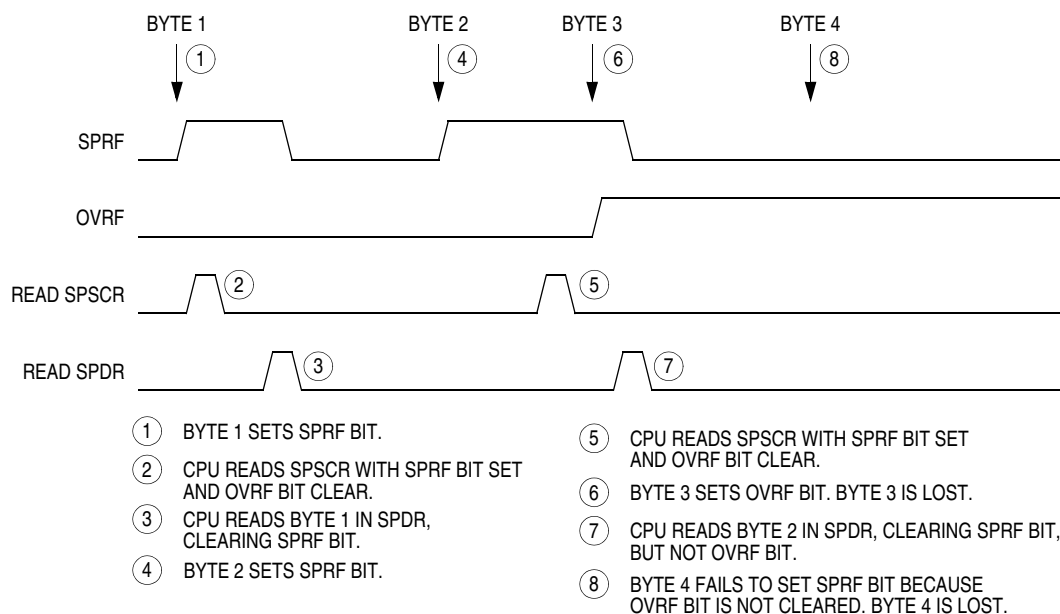

Figure 13-9. Missed Read of Overflow Condition

In this case, an overflow can easily be missed. Since no more SPRF interrupts can be generated until this OVRF is serviced, it is not obvious that bytes are being lost as more transmissions are completed. To prevent this, either enable the OVRF interrupt or do another read of the SPSCR following the read of the SPDR. This ensures that the OVRF was not set before the SPRF was cleared and that future transmissions can set the SPRF bit. [Figure 13-10](#) illustrates this process. Generally, to avoid this second SPSCR read, enable the OVRF to the CPU by setting the ERRIE bit.

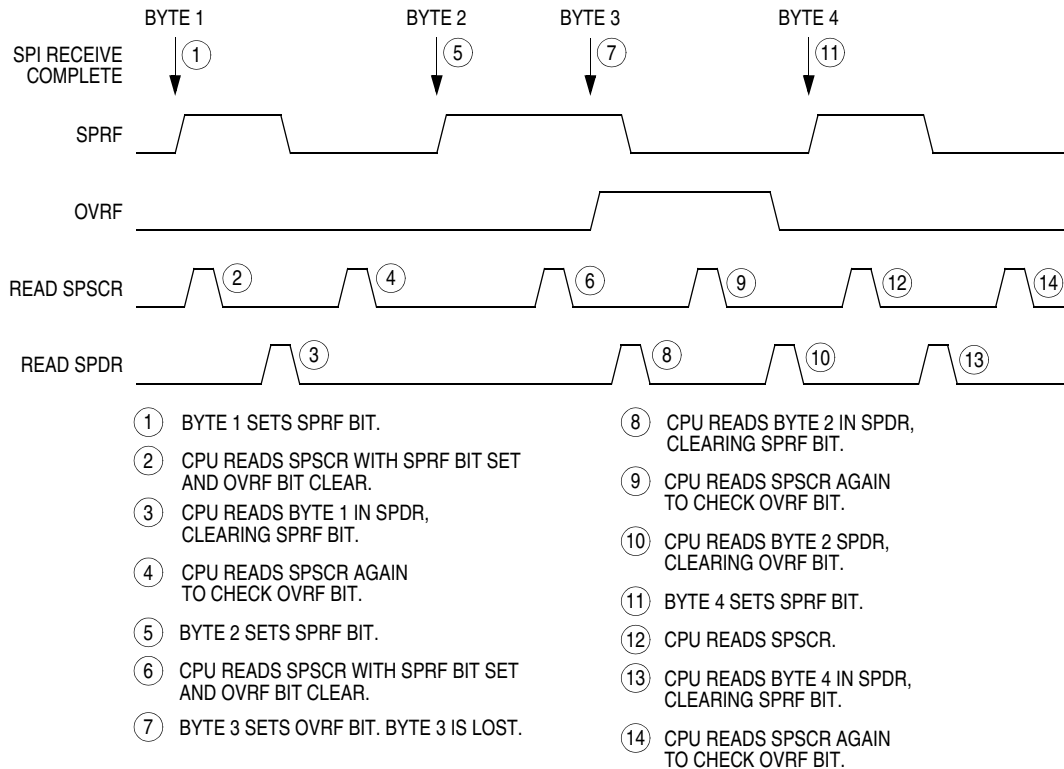

Figure 13-10. Clearing SPRF When OVRF Interrupt Is Not Enabled

13.7.2 Mode Fault Error

Setting the SPMSTR bit selects master mode and configures the SPSCCK and MOSI pins as outputs and the MISO pin as an input. Clearing SPMSTR selects slave mode and configures the SPSCCK and MOSI pins as inputs and the MISO pin as an output. The mode fault bit, MODF, becomes set any time the state of the slave select pin, \overline{SS} , is inconsistent with the mode selected by SPMSTR. To prevent SPI pin contention and damage to the MCU, a mode fault error occurs if:

- The \overline{SS} pin of a slave SPI goes high during a transmission.
- The \overline{SS} pin of a master SPI goes low at any time.

For the MODF flag to be set, the mode fault error enable bit (MODFEN) must be set. Clearing the MODFEN bit does not clear the MODF flag but does prevent MODF from being set again after MODF is cleared.

MODF generates a receiver/error CPU interrupt request if the error interrupt enable bit (ERRIE) is also set. The SPRF, MODF, and OVRF interrupts share the same CPU interrupt vector. It is not possible to enable MODF or OVRF individually to generate a receiver/error CPU interrupt request. However, leaving MODFEN low prevents MODF from being set.

Serial Peripheral Interface Module (SPI)

In a master SPI with the mode fault enable bit (MODFEN) set, the mode fault flag (MODF) is set if \overline{SS} goes to logic 0. A mode fault in a master SPI causes the following events to occur:

- If ERRIE = 1, the SPI generates an SPI receiver/error CPU interrupt request.
- The SPE bit is cleared.
- The SPTE bit is set.
- The SPI state counter is cleared.

When configured as a slave (SPMSTR = 0), the MODF flag is set if \overline{SS} goes high during a transmission. When CPHA = 0, a transmission begins when \overline{SS} goes low and ends once the incoming SPSCCK goes back to its idle level following the shift of the eighth data bit. When CPHA = 1, the transmission begins when the SPSCCK leaves its idle level and \overline{SS} is already low. The transmission continues until the SPSCCK returns to its idle level following the shift of the last data bit. (See [13.5 Transmission Formats](#).)

NOTE

Setting the MODF flag does not clear the SPMSTR bit. The SPMSTR bit has no function when SPE = 0. Reading SPMSTR when MODF = 1 shows the difference between a MODF occurring when the SPI is a master and when it is a slave.

NOTE

When CPHA = 0, a MODF occurs if a slave is selected (\overline{SS} is at logic 0) and later unselected (\overline{SS} is at logic 1) even if no SPSCCK is sent to that slave. This happens because \overline{SS} at logic 0 indicates the start of the transmission (MISO driven out with the value of MSB) for CPHA = 0. When CPHA = 1, a slave can be selected and then later unselected with no transmission occurring. Therefore, MODF does not occur since a transmission was never begun.

In a slave SPI (MSTR = 0), the MODF bit generates an SPI receiver/error CPU interrupt request if the ERRIE bit is set. The MODF bit does not clear the SPE bit or reset the SPI in any way. Software can abort the SPI transmission by clearing the SPE bit of the slave.

NOTE

A logic 1 voltage on the \overline{SS} pin of a slave SPI puts the MISO pin in a high impedance state. Also, the slave SPI ignores all incoming SPSCCK clocks, even if it was already in the middle of a transmission.

To clear the MODF flag, read the SPSCR with the MODF bit set and then write to the SPCR register. This entire clearing mechanism must occur with no MODF condition existing or else the flag is not cleared.

13.8 Interrupts

The four SPI status flags that can be enabled to generate CPU interrupt requests are discussed in [Table 13-1](#).

Reading the SPI status and control register with SPRF set and then reading the receive data register clears SPRF. The clearing mechanism for the SPTE flag is always just a write to the transmit data register.

The SPI transmitter interrupt enable bit (SPTIE) enables the SPTE flag to generate transmitter interrupt requests provided that the SPI is enabled (SPE = 1).

Table 13-1. SPI Interrupts

| Flag | Request |
|----------------------------|--|
| SPTIE Transmitter empty | SPI transmitter CPU interrupt request (DMAS = 0, SPTIE = 1, SPE = 1) |
| SPRF Receiver full | SPI receiver CPU interrupt request (DMAS = 0, SPRIE = 1) |
| OVRF Overflow | SPI receiver/error interrupt request (ERRIE = 1) |
| MODF Mode fault | SPI receiver/error interrupt request (ERRIE = 1) |

The SPI receiver interrupt enable bit (SPRIE) enables the SPRF bit to generate receiver interrupt requests regardless of the state of the SPE bit. (See [Figure 13-11](#).)

The error interrupt enable bit (ERRIE) enables both the MODF and OVRF bits to generate a receiver/error CPU interrupt request.

The mode fault enable bit (MODFEN) can prevent the MODF flag from being set so that only the OVRF bit is enabled by the ERRIE bit to generate receiver/error CPU interrupt requests.

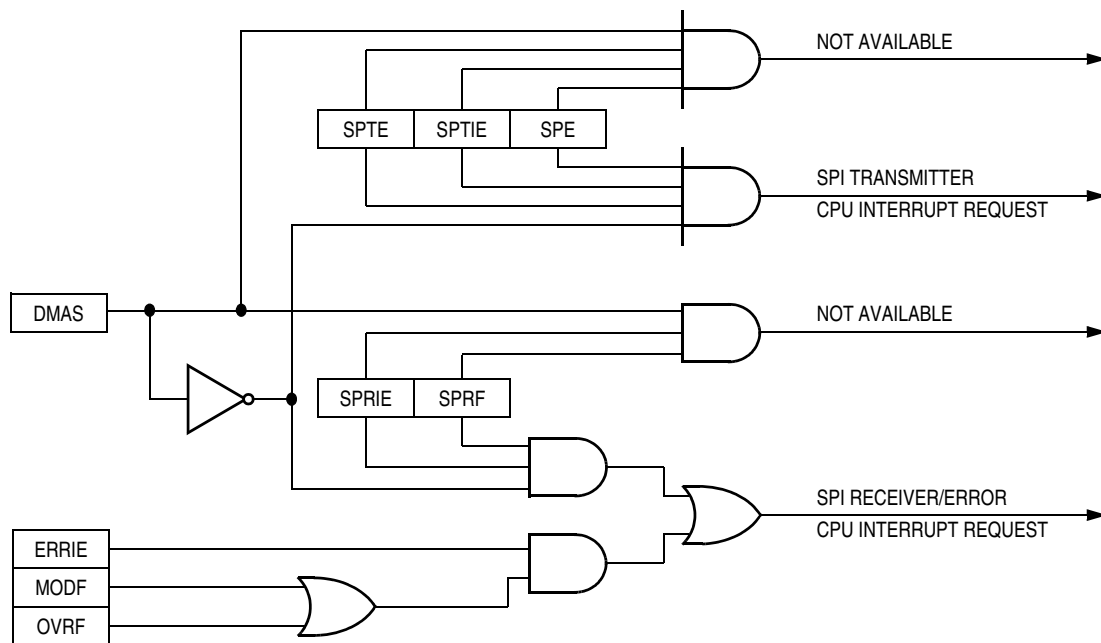

Figure 13-11. SPI Interrupt Request Generation

These sources in the SPI status and control register can generate interrupt requests:

- SPI receiver full bit (SPRF) — The SPRF bit becomes set every time a byte transfers from the shift register to the receive data register. If the SPI receiver interrupt enable bit, SPRIE, is also set, SPRF generates an SPI receiver/error CPU interrupt request.
- SPI transmitter empty (SPTIE) — The SPTIE bit becomes set every time a byte transfers from the transmit data register to the shift register. If the SPI transmit interrupt enable bit, SPTIE, is also set, SPTIE generates an SPTIE CPU interrupt request or an SPTIE DMA service request.

13.9 Resetting the SPI

Any system reset completely resets the SPI. Partial resets occur whenever the SPI enable bit (SPE) is low. Whenever SPE is low, the following occurs:

- The SPTE flag is set.
- Any transmission currently in progress is aborted.
- The shift register is cleared.
- The SPI state counter is cleared, making it ready for a new complete transmission.

These items are reset only by a system reset:

- All control bits in the SPCR register
- All control bits in the SPSCR register (MODFEN, ERRIE, SPR1, and SPR0)
- The status flags SPRF, OVRF, and MODF

By not resetting the control bits when SPE is low, the user can clear SPE between transmissions without having to set all control bits again when SPE is set back high for the next transmission.

By not resetting the SPRF, OVRF, and MODF flags, the user can still service these interrupts after the SPI has been disabled. The user can disable the SPI by writing 0 to the SPE bit. The SPI can also be disabled by a mode fault occurring in an SPI that was configured as a master with the MODFEN bit set.

13.10 Wait Mode

The SPI module remains active after the execution of a WAIT instruction. In wait mode, the SPI module registers are not accessible by the CPU. Any enabled CPU interrupt request from the SPI module can bring the MCU out of wait mode.

If SPI module functions are not required during wait mode, reduce power consumption by disabling the SPI module before executing the WAIT instruction.

13.11 SPI During Break Interrupts

The system integration module (SIM) controls whether status bits in other modules can be cleared during the break state. The BCFE bit in the SIM break flag control register (SBFCR) enables software to clear status bits during the break state. (See [6.7.3 SIM Break Flag Control Register](#).)

To allow software to clear status bits during a break interrupt, write a logic 1 to the BCFE bit. If a status bit is cleared during the break state, it remains cleared when the MCU exits the break state.

To protect status bits during the break state, write a logic 0 to the BCFE bit. With BCFE at logic 0 (its default state), software can read and write I/O registers during the break state without affecting status bits. Some status bits have a 2-step read/write clearing procedure. If software does the first step on such a bit before the break, the bit cannot change during the break state as long as BCFE is at logic 0. After the break, doing the second step clears the status bit.

Since the SPTE bit cannot be cleared during a break with the BCFE bit cleared, a write to the transmit data register in break mode does not initiate a transmission nor is this data transferred into the shift register. Therefore, a write to the SPDR in break mode with the BCFE bit cleared has no effect.

13.12 I/O Signals

The SPI module has five dedicated I/O pins.

- MISO — Data received
- MOSI — Data transmitted
- SPSCCK — Serial clock
- \overline{SS} — Slave select
- EV_{SS} — Clock ground

The SPI has limited inter-integrated circuit (I²C) capability (requiring software support) as a master in a single-master environment. To communicate with I²C peripherals, MOSI becomes an open-drain output when the SPWOM bit in the SPI control register is set. In I²C communication, the MOSI and MISO pins are connected to a bidirectional pin from the I²C peripheral and through a pullup resistor to V_{DD} .

13.12.1 Master In/Slave Out (MISO)

MISO is one of the two SPI module pins that transmits serial data. In full-duplex operation, the MISO pin of the master SPI module is connected to the MISO pin of the slave SPI module. The master SPI simultaneously receives data on its MISO pin and transmits data from its MOSI pin.

Slave output data on the MISO pin is enabled only when the SPI is configured as a slave. The SPI is configured as a slave when its SPMSTR bit is logic 0 and its \overline{SS} pin is at logic 0. To support a multiple-slave system, a logic 1 on the \overline{SS} pin puts the MISO pin in a high-impedance state.

When enabled, the SPI controls data direction of the MISO pin regardless of the state of the data direction register of the shared I/O port.

NOTE

The MISO pin on this device is not shared with an I/O port.

13.12.2 Master Out/Slave In (MOSI)

MOSI is one of the two SPI module pins that transmits serial data. In full duplex operation, the MOSI pin of the master SPI module is connected to the MOSI pin of the slave SPI module. The master SPI simultaneously transmits data from its MOSI pin and receives data on its MISO pin.

When enabled, the SPI controls data direction of the MOSI pin regardless of the state of the data direction register of the shared I/O port.

NOTE

The MOSI pin on this device is not shared with an I/O port.

13.12.3 Serial Clock (SPSCCK)

The serial clock synchronizes data transmission between master and slave devices. In a master MCU, the SPSCCK pin is the clock output. In a slave MCU, the SPSCCK pin is the clock input. In full-duplex operation, the master and slave MCUs exchange a byte of data in eight serial clock cycles.

When enabled, the SPI controls data direction of the SPSCCK pin regardless of the state of the data direction register of the shared I/O port.

NOTE

The SPSCCK pin on this device is not shared with an I/O port.

13.12.4 Slave Select (\overline{SS})

The \overline{SS} pin has various functions depending on the current state of the SPI. For an SPI configured as a slave, the \overline{SS} is used to select a slave. For CPHA = 0, the \overline{SS} is used to define the start of a transmission. (See [13.5 Transmission Formats](#).) Since it is used to indicate the start of a transmission, the \overline{SS} must be toggled high and low between each byte transmitted for the CPHA = 0 format. However, it can remain low between transmissions for the CPHA = 1 format. See [Figure 13-12](#).

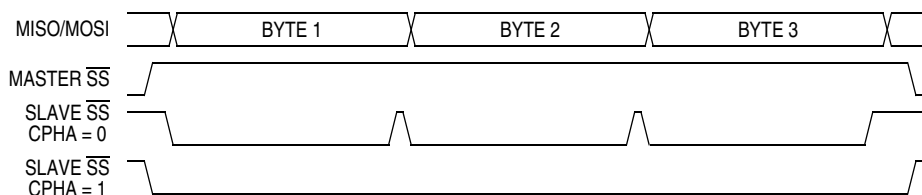

Figure 13-12. CPHA/ \overline{SS} Timing

When an SPI is configured as a slave, the \overline{SS} pin is always configured as an input. It cannot be used as a general-purpose I/O regardless of the state of the MODFEN control bit. However, the MODFEN bit can still prevent the state of the \overline{SS} from creating a MODF error. (See [13.13.2 SPI Status and Control Register](#).)

NOTE

A logic 1 voltage on the \overline{SS} pin of a slave SPI puts the MISO pin in a high-impedance state. The slave SPI ignores all incoming SPSCCK clocks, even if it was already in the middle of a transmission.

When an SPI is configured as a master, the \overline{SS} input can be used in conjunction with the MODF flag to prevent multiple masters from driving MOSI and SPSCCK. (See [13.7.2 Mode Fault Error](#).) For the state of the \overline{SS} pin to set the MODF flag, the MODFEN bit in the SPSCCK register must be set. If the MODFEN bit is low for an SPI master, the \overline{SS} pin can be used as a general-purpose I/O under the control of the data direction register of the shared I/O port. With MODFEN high, it is an input-only pin to the SPI regardless of the state of the data direction register of the shared I/O port.

NOTE

The \overline{SS} pin on this device cannot be used as a general-purpose I/O.

The CPU can always read the state of the \overline{SS} pin by configuring the appropriate pin as an input and reading the port data register. (See [Table 13-2](#).)

Table 13-2. SPI Configuration

| SPE | SPMSTR | MODFEN | SPI configuration | State of \overline{SS} logic |
|-----|------------------|--------|---------------------|---|
| 0 | X ⁽¹⁾ | X | Not enabled | General-purpose I/O; \overline{SS} ignored by SPI |
| 1 | 0 | X | Slave | Input-only to SPI |
| 1 | 1 | 0 | Master without MODF | General-purpose I/O; \overline{SS} ignored by SPI |
| 1 | 1 | 1 | Master with MODF | Input-only to SPI |

1. X = Don't Care

13.12.5 Clock Ground (EV_{SS})

EV_{SS} is the ground return for the serial clock pin, SPSCCK, and the ground for the port output buffers.

13.13 I/O Registers

Three registers control and monitor SPI operation:

- SPI control register (SPCR)
- SPI status and control register (SPSCR)
- SPI data register (SPDR)

13.13.1 SPI Control Register

The SPI control register:

- Enables SPI module interrupt requests
- Selects CPU interrupt requests
- Configures the SPI module as master or slave
- Selects serial clock polarity and phase
- Configures the SPSCK, MOSI, and MISO pins as open-drain outputs
- Enables the SPI module

| | | | | | | | | |
|----------|--------|------|--------|------|------|-------|-----|-------|
| Address: | \$000D | | | | | | | |
| | Bit 7 | 6 | 5 | 4 | 3 | 2 | 1 | Bit 0 |
| Read: | SPRIE | DMAS | SPMSTR | CPOL | CPHA | SPWOM | SPE | SPTIE |
| Write: | | | | | | | | |
| Reset: | 0 | 0 | 1 | 0 | 1 | 0 | 0 | 0 |

Figure 13-13. SPI Control Register (SPCR)

SPRIE — SPI receiver interrupt enable bit

This read/write bit enables interrupt requests generated by the SPRF bit. The SPRF bit is set when a byte transfers from the shift register to the receive data register.

- 1 = SPRF CPU interrupt requests or SPRF DMA service requests enabled
- 0 = SPRF CPU interrupt requests or SPRF DMA service requests disabled

DMAS —DMA select bit

This read/write bit has no effect on this version of the SPI. This bit always read as 0.

- 0 = SPRE DMA and SPTE DMA service requests disabled

SPMSTR — SPI master bit

This read/write bit selects master mode operation or slave mode operation.

- 1 = Master mode
- 0 = Slave mode

CPOL — Clock polarity bit

This read/write bit determines the logic state of the SPSCK pin between transmissions. (See [Figure 13-4](#) and [Figure 13-6](#).) To transmit data between SPI modules, the SPI modules must have identical CPOL values.

CPHA — Clock phase bit

This read/write bit controls the timing relationship between the serial clock and SPI data. (See [Figure 13-4](#) and [Figure 13-6](#).) To transmit data between SPI modules, the SPI modules must have identical CPHA values. When CPHA = 0, the \overline{SS} pin of the slave SPI module must be set to logic 1 between bytes. (See [Figure 13-12](#).)

Serial Peripheral Interface Module (SPI)

SPWOM — SPI wired-OR mode bit

This read/write bit disables the pullup devices on pins SPSCCK, MOSI, and MISO pins so that those pins become open-drain outputs.

- 1 = Wired-OR SPSCCK, MOSI, and MISO pins
- 0 = Normal push-pull SPSCCK, MOSI, and MISO pins

SPE — SPI enable bit

This read/write bit enables the SPI module. Clearing SPE causes a partial reset of the SPI. (See [13.9 Resetting the SPI.](#))

- 1 = SPI module enabled
- 0 = SPI module disabled

SPTIE— SPI transmit interrupt enable bit

This read/write bit enables interrupt requests generated by the SPTE bit. SPTE is set when a byte transfers from the transmit data register to the shift register.

- 1 = SPTE interrupt requests enabled
- 0 = SPTE interrupt requests disabled

13.13.2 SPI Status and Control Register

The SPI status and control register contains flags to signal these conditions:

- Receive data register full
- Failure to clear SPRF bit before next byte is received (overflow error)
- Inconsistent logic level on \overline{SS} pin (mode fault error)
- Transmit data register empty

The SPI status and control register also contains bits that perform these functions:

- Enable error interrupts
- Enable mode fault error detection
- Select master SPI baud rate

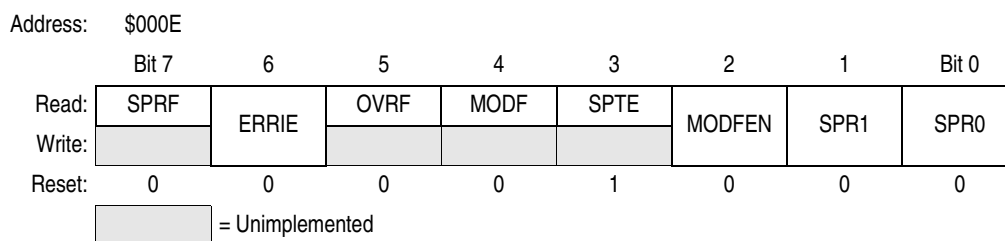

Figure 13-14. SPI Status and Control Register (SPSCR)

SPRF — SPI receiver full bit

This clearable, read-only flag is set each time a byte transfers from the shift register to the receive data register. SPRF generates an interrupt request if the SPRIE bit in the SPI control register is set also.

- 1 = Receive data register full
- 0 = Receive data register not full

ERRIE — Error interrupt enable bit

This read/write bit enables the MODF and OVRF bits to generate CPU interrupt requests. Reset clears the ERRIE bit.

- 1 = MODF and OVRF can generate CPU interrupt requests.
- 0 = MODF and OVRF cannot generate CPU interrupt requests.

OVRF — Overflow bit

This clearable, read-only flag is set if software does not read the byte in the receive data register before the next full byte enters the shift register. In an overflow condition, the byte already in the receive data register is unaffected, and the byte that shifted in last is lost. Clear the OVRF bit by reading the SPI status and control register with OVRF set and then reading the receive data register.

- 1 = Overflow
- 0 = No overflow

MODF — Mode fault bit

This clearable, read-only flag is set in a slave SPI if the \overline{SS} pin goes high during a transmission with the MODFEN bit set. In a master SPI, the MODF flag is set if the \overline{SS} pin goes low at any time with the MODFEN bit set. Clear the MODF bit by reading the SPI status and control register (SPSCR) with MODF set and then writing to the SPI control register (SPCR).

- 1 = \overline{SS} pin at inappropriate logic level
- 0 = \overline{SS} pin at appropriate logic level

SPTE — SPI transmitter empty bit

This clearable, read-only flag is set each time the transmit data register transfers a byte into the shift register. SPTE generates an interrupt request if the SPTIE bit in the SPI control register is set also.

- 1 = Transmit data register empty
- 0 = Transmit data register not empty

NOTE

Do not write to the SPI data register unless the SPTE bit is high.

MODFEN — Mode fault enable bit

This read/write bit, when set to 1, allows the MODF flag to be set. If the MODF flag is set, clearing the MODFEN does not clear the MODF flag.

If the MODFEN bit is low, the level of the \overline{SS} pin does not affect the operation of an enabled SPI configured as a master. For an enabled SPI configured as a slave, having MODFEN low only prevents the MODF flag from being set. It does not affect any other part of SPI operation. (See [13.7.2 Mode Fault Error](#).)

SPR1 and SPR0 — SPI baud rate select bits

In master mode, these read/write bits select one of four baud rates as shown in [Table 13-3](#). SPR1 and SPR0 have no effect in slave mode. Reset clears SPR1 and SPR0.

Use this formula to calculate the SPI baud rate:

$$\text{Baud rate} = \frac{\text{CGMOUT}}{2 \times \text{BD}}$$

- CGMOUT = base clock output of the clock generator module (CGM)
- BD = baud rate divisor

Table 13-3. SPI Master Baud Rate Selection

| SPR1 and SPR0 | Baud rate divisor (BD) |
|---------------|------------------------|
| 00 | 2 |
| 01 | 8 |
| 10 | 32 |
| 11 | 128 |

13.13.3 SPI Data Register

The SPI data register consists of the read-only receive data register and the write-only transmit data register. Writing to the SPI data register writes data into the transmit data register. Reading the SPI data register reads data from the receive data register. The transmit data and receive data registers are separate registers that can contain different values. (See [Figure 13-2](#).)

Address: \$000F

| | Bit 7 | 6 | 5 | 4 | 3 | 2 | 1 | Bit 0 |
|--------|---------------------------|----|----|----|----|----|----|-------|
| Read: | R7 | R6 | R5 | R4 | R3 | R2 | R1 | R0 |
| Write: | T7 | T6 | T5 | T4 | T3 | T2 | T1 | T0 |
| Reset: | Indeterminate after reset | | | | | | | |

Figure 13-15. SPI Data Register (SPDR)

R7–R0/T7–T0 — Receive/transmit data bits

NOTE

Do not use read-modify-write instructions on the SPI data register since the register read is not the same as the register written.

Chapter 14

Alert Output Generator (ALR)

14.1 Introduction

This section describes the alert output generator (ALR), which provides 14 software selectable square wave output frequencies.

14.2 Features

Features of the ALR module include:

- 14 software selectable audio alert tone outputs
- 4-bit software selectable sound pressure level control

14.3 Functional Description

This system will be used to generate alert tones as the output signal ALERT. The audio alert tone generator is controlled by the four control bits as shown in [Table 14-1](#). This allows 14 possible frequencies to drive the alert output. The zero state acts as an off mode and places the output in a high-impedance mode and an on mode places the output in ground state.

NOTE

The alert module is enabled only when the on-chip phase locked loop (PLL) is engaged. During wait mode, the ALCR register should be programmed with value \$00 to ensure a three-state output and eliminate any residual output from the audio frequency generator.

Table 14-1. Audio Alert Tone Generator Divider Ratios

| AL3-AL0 | Audio alert generator frequencies at given f_{OSC} | | | |
|---------|--|------------|------------|----------|
| | f_{OSC} | 32.768 kHz | 32.000 kHz | 38.4 kHz |
| 0000 | OFF | Hi-Z | Hi-Z | Hi-Z |
| 0001 | $f_{OSC} \div 32$ | 1024 | 10001 | 1200 |
| 0010 | $f_{OSC} \div 8$ | 4096 | 4000 | 4800 |
| 0011 | $f_{OSC} \div 16$ | 2048 | 2000 | 2400 |
| 0100 | $f_{OSC} \div 6$ | 5461 | 5333 | 6400 |
| 0101 | $f_{OSC} \div 12$ | 2730 | 2666 | 3200 |
| 0110 | $f_{OSC} \div 24$ | 1365 | 1333 | 1600 |
| 0111 | $f_{OSC} \div 48$ | 683 | 667 | 800 |

Continued on next page

Table 14-1. Audio Alert Tone Generator Divider Ratios (Continued)

| AL3–AL0 | Audio alert generator frequencies at given f_{osc} | | | |
|---------|--|------------|------------|----------|
| | f_{osc} | 32.768 kHz | 32.000 kHz | 38.4 kHz |
| 1000 | $f_{osc} \div 10$ | 3276 | 3200 | 3840 |
| 1001 | $f_{osc} \div 20$ | 1638 | 1600 | 1920 |
| 1010 | $f_{osc} \div 40$ | 819 | 800 | 960 |
| 1011 | $f_{osc} \div 80$ | 410 | 400 | 480 |
| 1100 | $f_{osc} \div 14$ | 2341 | 2285 | 2743 |
| 1101 | $f_{osc} \div 28$ | 1170 | 1143 | 1371 |
| 1110 | $f_{osc} \div 56$ | 585 | 571 | 686 |
| 1111 | OFF | V_{SS} | V_{SS} | V_{SS} |

14.3.1 Alert Control Register

The alert control register (ALCR) bits are in [Figure 14-1](#).

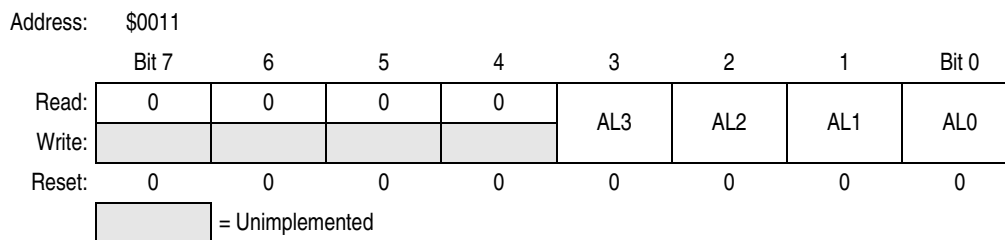

Figure 14-1. Alert Control Register (ALCR)

AL3–AL0 — Alert frequency select bits

The value of these bits determines the frequency of the alert output (see [Table 14-1](#)). If these bits are set to all 0s, the ALERT output will be high impedance (OFF). If set to all 1s, the ALERT output will be at V_{SS} (logic 0).

Reset clears these bits, turning this output off to the high-impedance state.

14.3.2 Sound Pressure Level Circuit

The sound pressure level (SPL) control register is used to control the volume of the alert transducer. A high-frequency clock signal is used to modulate the normal alert output frequency. This modulation reduces the amplitude of the frequency components in the audible range while adding new frequencies outside the audible range.

This feature causes a significant reduction in the SPL of the transducer. A broad range of volume control is obtained by altering the duty cycle of the high frequency modulation signal. The SPL control register is software programmable to allow users to select different frequencies with different duty cycles.

14.3.3 Alert Data Register

The alert data register (ALDR) bits are:

| | | | | | | | | |
|----------|--------|------|------|------|------|------|------|-------|
| Address: | \$0012 | | | | | | | |
| | Bit 7 | 6 | 5 | 4 | 3 | 2 | 1 | Bit 0 |
| Read: | SPL7 | SPL6 | SPL5 | SPL4 | SPL3 | SPL2 | SPL1 | SPL0 |
| Write: | | | | | | | | |
| Reset: | 0 | 0 | 0 | 0 | 0 | 0 | 0 | 0 |

Figure 14-2. Alert Data Register (ALDR)

SPL7 bit

This bit selects between 16-phase duty cycle modulation if bit SPL7 = 0 and 8-phase duty cycle modulation if bit SPL7 = 1.

SPL6 bit

This bit selects between the output (DCMOD) of the duty cycle modulator when SPL6 = 0 and the clock FMODHI when SPL6 = 1 to send to the output SPLCLK to modulate the alert output.

(See [Figure 14-3](#).)

SPL5 and SPL4 bits

These bits are used to control the frequency divider selections (divided by 1, 2, and 4) and, along with bit SPL6 in one case where both SPL4 and SPL5 are high, to select between a CPU clock divided by 8 and the crystal clock. (See [Table 14-2](#).)

Table 14-2. Clock Divider and Modulator Selections

| SPL6 | SPL5 | SPL4 | FMODHI | SPLCLK |
|------|------|------|---------|--------|
| 0 | 0 | 0 | IT12/1 | DCMOD |
| 0 | 0 | 01 | IT12/2 | DCMOD |
| 0 | 1 | 0 | IT12/4 | DCMOD |
| 0 | 1 | 1 | IT12/8 | DCMOD |
| 1 | 0 | 0 | IT12/1 | FMODHI |
| 1 | 0 | 1 | IT12/2 | FMODHI |
| 1 | 1 | 0 | IT12/4 | FMODHI |
| 1 | 1 | 1 | CGMXCLK | FMODHI |

SPL3–SPL0 bits

These bits control the duty cycle of the modulation signal, as shown in [Table 14-3](#).

Table 14-3. Duty Cycle Selection

| SPL3 | SPL2 | SPL1 | SPL0 | Duty cycle 8-phase count (SPL7 = 1) | Duty cycle 16-phase count (SPL7 = 0) |
|------|------|------|------|-------------------------------------|--------------------------------------|
| 0 | 0 | 0 | 0 | SPL disabled | SPL disabled |
| 0 | 0 | 0 | 1 | 1/8 high 7/8 low | 1/16 high 15/16 low |
| 0 | 0 | 1 | 0 | 2/8 high 6/8 low | 2/16 high 14/16 low |
| 0 | 0 | 1 | 1 | 3/8 high 5/8 low | 3/16 high 13/16 low |
| 0 | 1 | 0 | 0 | 4/8 high 4/8 low | 4/16 high 12/16 low |

Continued on next page

Table 14-3. Duty Cycle Selection (Continued)

| SPL3 | SPL2 | SPL1 | SPL0 | Duty cycle 8-phase count (SPL7 = 1) | Duty cycle 16-phase count (SPL7 = 0) |
|------|------|------|------|---|--|
| 0 | 1 | 0 | 1 | 5/8 high 3/8 low | 5/16 high 11/16 low |
| 0 | 1 | 1 | 0 | 6/8 high 2/8 low | 6/16 high 10/16 low |
| 0 | 1 | 1 | 1 | 7/8 high 1/8 low | 7/16 high 9/16 low |
| 1 | 0 | 0 | 0 | SPL disabled | 8/16 high 8/16 low |
| 1 | 0 | 0 | 1 | 1/8 high 7/8 low | 9/16 high 7/16 low |
| 1 | 0 | 1 | 0 | 2/8 high 6/8 low | 10/16 high 6/16 low |
| 1 | 0 | 1 | 1 | 3/8 high 5/8 low | 11/16 high 5/16 low |
| 1 | 1 | 0 | 0 | 4/8 high 4/8 low | 12/16 high 4/16 low |
| 1 | 1 | 0 | 1 | 5/8 high 3/8 low | 13/16 high 3/16 low |
| 1 | 1 | 1 | 0 | 6/8 high 2/8 low | 14/16 high 2/16 low |
| 1 | 1 | 1 | 1 | 7/8 high 1/8 low | 15/16 high 1/16 low |

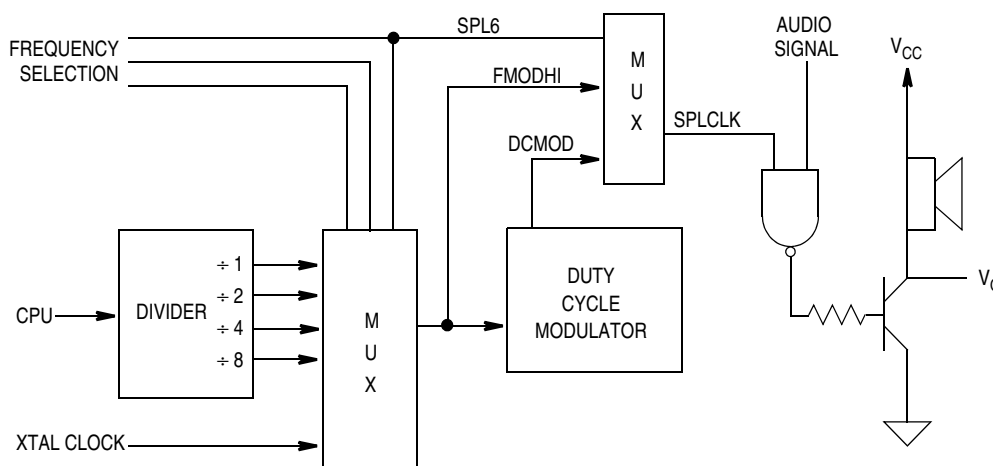

Figure 14-3. Block Diagram of SPL Reduction Circuit

Chapter 15

Liquid Crystal Display Module (LCD)

15.1 Introduction

The liquid crystal display (LCD) module provides software control for eight backplanes and either 10 or 85 frontplanes.

15.2 Features

Features of the LCD module include:

- Built-in voltage generator charge pump
- Software selectable three, five, or eight backplanes
- Software selectable 10 or 85 frontplanes
- Anti-ghosting capability

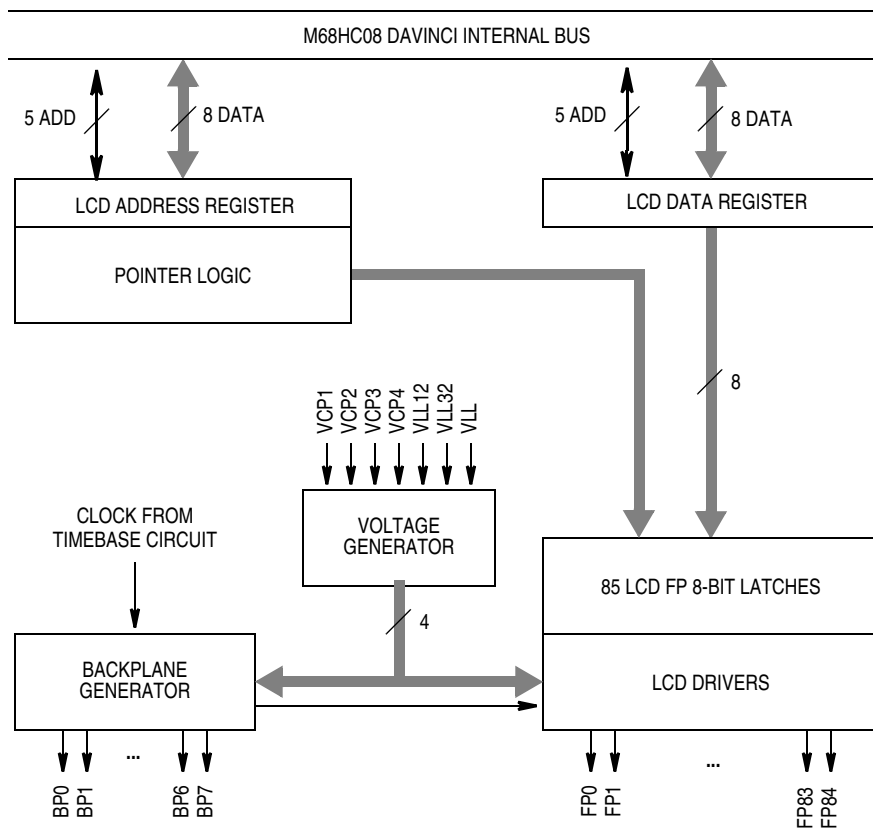

Figure 15-1. LCD Driver Block Diagram

15.3 Functional Description

This LCD driver circuit has a maximum of eight backplanes (BP) and 85 frontplanes (FP). The output waveform has a maximum output level of $3/2 V_{LL}$ and is configured with $1/3$ bias. The output voltage levels are V_{SS} , $1/2 V_{LL}$, V_{LL} , and $3/2 V_{LL}$ (V_{LL} – LCD power supply). The bias voltage levels are generated internally from the external inputs V_{LL} , V_{CP1} – V_{CP4} , V_{LL12} , and V_{LL32} . For more information on using the LCD voltage converter, see the functional pin description in [15.7 Power Supply Pins \(VLL, VLL12, VLL32, and VCP1–VCP4\)](#).

15.4 LCD Registers

The LCD driver outputs are manipulated through software control of the LCD control register, the LCD address register, and the LCD data register. Data is written to each of the 85 frontplanes by writing the FP number to the LCD address register and then writing the data to the LCD data register.

15.4.1 LCD Control Register

The LCD control register (LCDCR) is a read/write register containing the control bits to configure the LCD drivers.

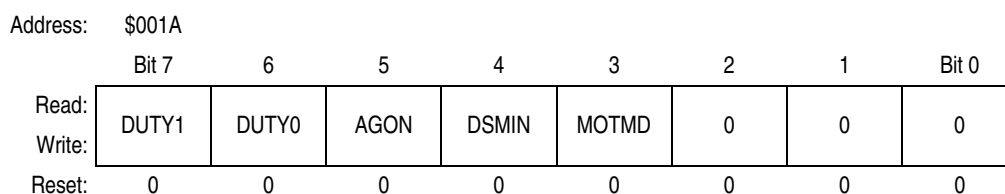

Figure 15-2. LCD Control Register (LCDCR)

DUTY1 and DUTY0 — Duty cycle select bits

These bits enable all FP outputs and select the duty of the LCD driver, enabling the specified number of BP outputs. Reset clears these bits, disabling LCD waveforms at the outputs. When disabled, an LCD output will be held at V_{SS} . [Table 15-1](#) shows the duty cycle selected and the corresponding number of backplanes, as well as the frame rate for the chosen duty cycle.

Table 15-1. Duty Cycle Select

| DUTY1–DUTY0 | DUTY | Number of backplanes | Frame rate $f_{OSC} = 32.000 \text{ kHz}$ | Frame rate $f_{OSC} = 38.4 \text{ kHz}$ |
|-------------|------|----------------------|--|--|
| 00 | OFF | OFF | OFF | OFF |
| 01 | 1/3 | 3 | 27.8 Hz | 33.3 Hz |
| 10 | 1/5 | 5 | 25.0 Hz | 30.0 Hz |
| 11 | 1/8 | 8 | 31.25 Hz | 37.5 Hz |

AGON — Anti-ghost on bit

This bit is used to turn the anti-ghosting feature on or off. When $AGON = 1$, the anti-ghosting feature is enabled. When $AGON = 0$, anti-ghosting is turned off. For additional information, see [15.5 Anti-Ghosting](#). This bit is cleared by reset.

DSMIN — Display minimum bit

This bit is used to force the data of the lower 75 FP (FP0–FP74) to be 0. This mode is used to enable only part of the display to be on (for example, clock display) without having to rewrite the data on the rest of the display to 0.

MOTMD — Multiplex mode bit

This bit can be used to convert the LCD outputs to accommodate multiplexed LCD driver ICs (integrated circuits) from Freescale (MC145000 and MC145001).

- 1 = Freescale (multiplex) mode enabled
- 0 = Standard (lower current consumption) mode enabled

15.4.2 LCD Address Register

The LCD address register (LCDAR) is a read/write register used to access the data for each FP register.

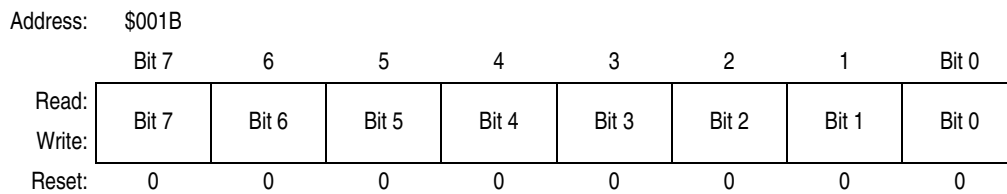

Figure 15-3. LCD Address Register (LCDAR)

To access the FP registers, the LCD address is the frontplane pin number converted to hexadecimal. For this implementation of 85 frontplanes, bit 7 is always set to 0. (See [Table 15-2.](#))

Table 15-2. Frontplane Address Assignments

| Pin name | Address | Pin name | Address |
|----------|---------|----------|---------|
| FP0 | \$01 | FP45 | \$2E |
| FP1 | \$02 | FP46 | \$2F |
| FP2 | \$03 | FP47 | \$30 |
| FP3 | \$04 | FP48 | \$31 |
| FP4 | \$05 | FP49 | \$32 |
| FP5 | \$06 | FP50 | \$33 |
| FP6 | \$07 | FP51 | \$34 |
| FP7 | \$08 | FP52 | \$35 |
| FP8 | \$09 | FP53 | \$36 |
| FP9 | \$0A | FP54 | \$37 |
| FP10 | \$0B | FP55 | \$38 |
| FP11 | \$0C | FP56 | \$39 |
| FP12 | \$0D | FP57 | \$3A |
| FP13 | \$0E | FP58 | \$3B |
| FP14 | \$0F | FP59 | \$3C |
| FP15 | \$10 | FP60 | \$3D |
| FP16 | \$11 | FP61 | \$3E |
| FP17 | \$12 | FP62 | \$3F |
| FP18 | \$13 | FP63 | \$40 |
| FP19 | \$14 | FP64 | \$41 |

Continued on next page

Table 15-2. Frontplane Address Assignments (Continued)

| Pin name | Address | Pin name | Address |
|----------|---------|----------|---------|
| FP20 | \$15 | FP65 | \$42 |
| FP22 | \$16 | FP66 | \$43 |
| FP23 | \$17 | FP67 | \$44 |
| FP24 | \$18 | FP68 | \$45 |
| FP25 | \$19 | FP69 | \$46 |
| FP25 | \$1A | FP70 | \$47 |
| FP26 | \$1B | FP71 | \$48 |
| FP27 | \$1C | FP72 | \$49 |
| FP28 | \$1D | FP73 | \$4A |
| FP29 | \$1E | FP74 | \$4B |
| FP30 | \$1F | FP75 | \$4C |
| FP31 | \$20 | FP76 | \$4D |
| FP32 | \$21 | FP77 | \$4E |
| FP33 | \$22 | FP78 | \$4F |
| FP34 | \$23 | FP79 | \$50 |
| FP35 | \$24 | FP80 | \$51 |
| FP36 | \$25 | FP81 | \$52 |
| FP37 | \$26 | FP82 | \$53 |
| FP38 | \$27 | FP83 | \$54 |
| FP39 | \$28 | FP84 | \$55 |
| FP40 | \$29 | | |
| FP41 | \$2A | | |
| FP42 | \$2B | | |
| FP43 | \$2C | | |
| FP44 | \$2D | | |

15.4.3 LCD Data Register

Each bit in the read/write LCD data register (LCDDR) is the data to be written out on to the FP pin, as specified in the LCD address register, in the appropriate BP time frame. The correct address must be written into the LCD address register before reading from or writing to the LCD data register. The data in this register is for all the segments controlled by the FP driver.

If the user has selected less than eight backplanes, the upper bits of this register will be unknown.

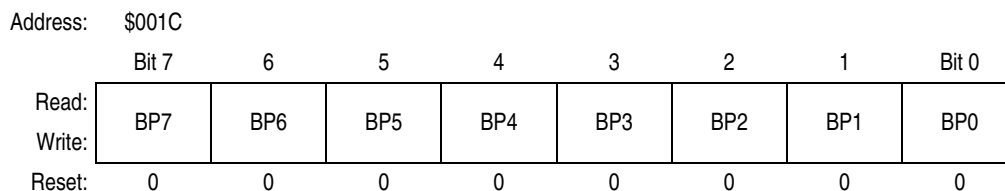

Figure 15-4. LCD Data Register (LCDDR)

BPx

- 1 = FP output ON during BPx time frame
- 0 = FP output OFF during BPx time frame

For example, if the segment controlled by FP1 and BP4 is to be on, follow this sequence:

1. Write \$02 to the LCD address register.
2. Write 1 to bit 4 of the LCD data register.

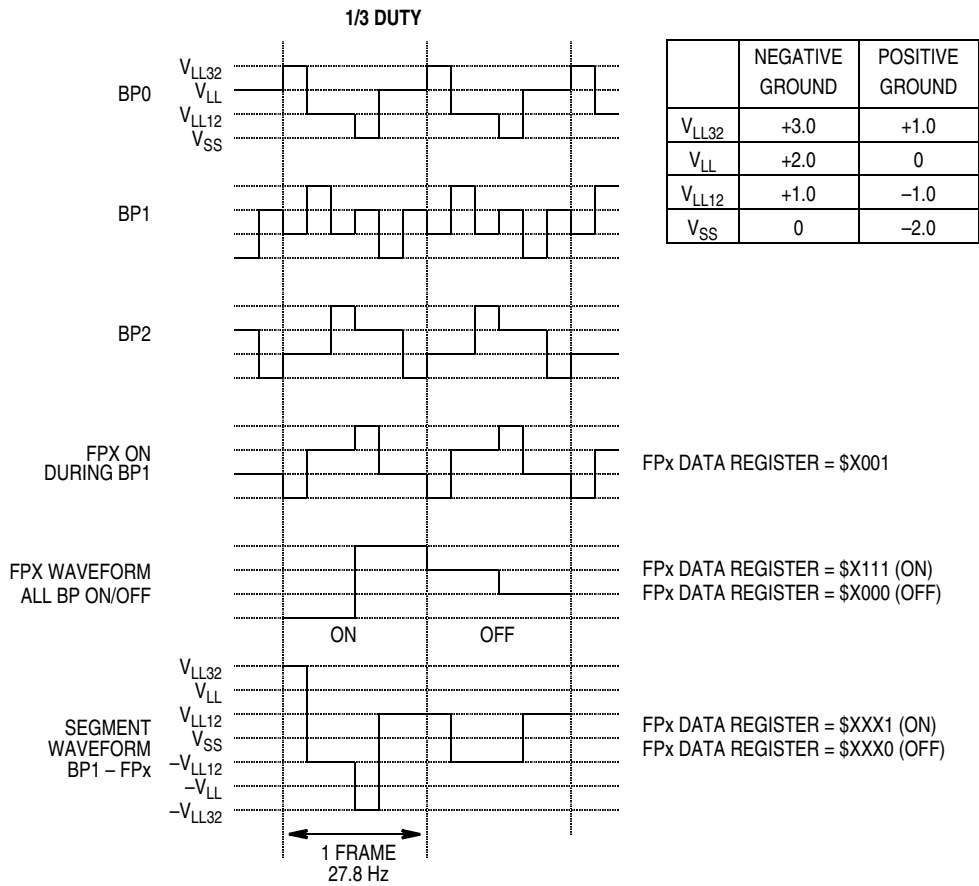

Figure 15-5. LCD Backplane Waveforms — 3 BP

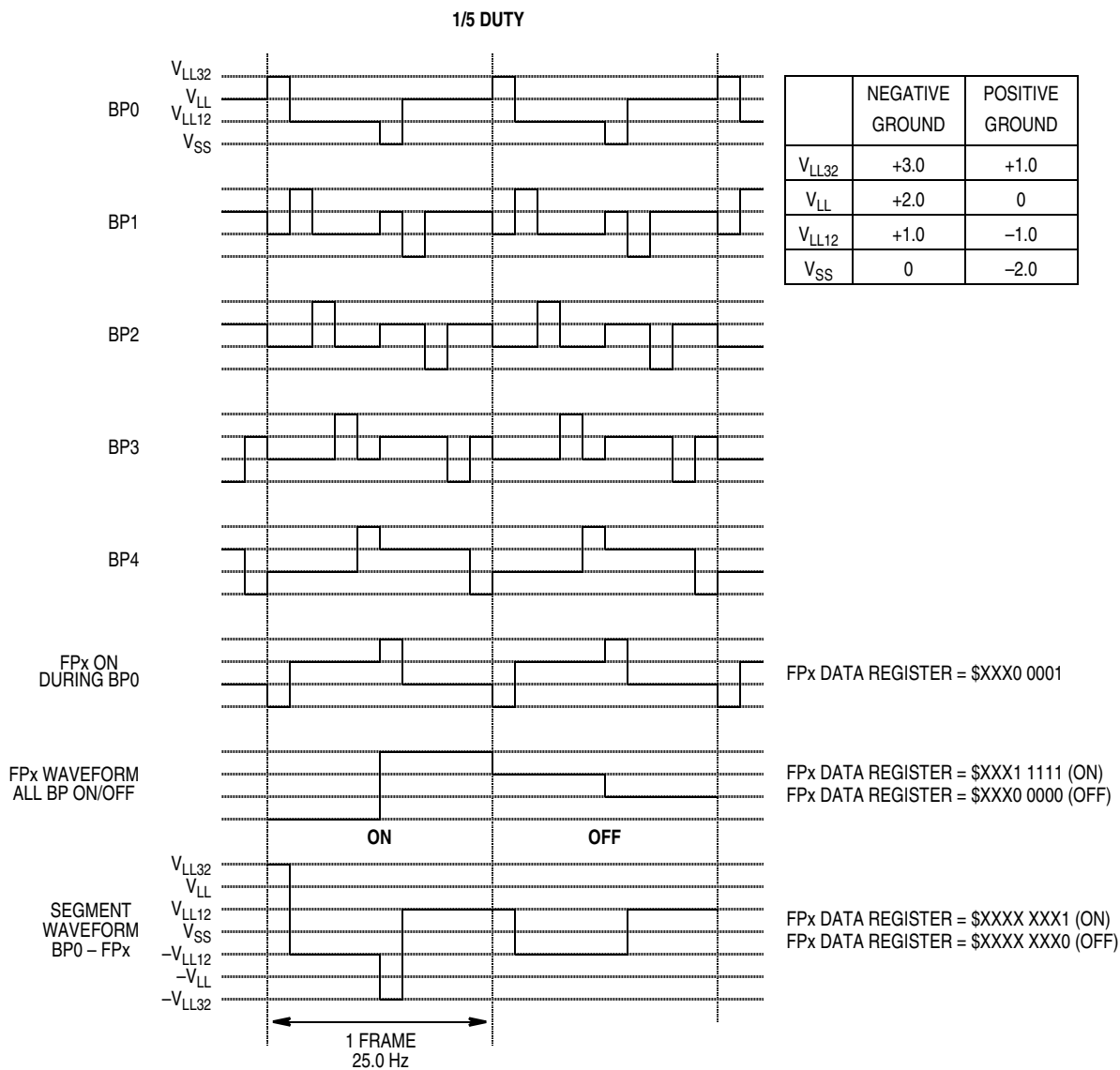

Figure 15-6. LCD Backplane Waveforms — 5 BP

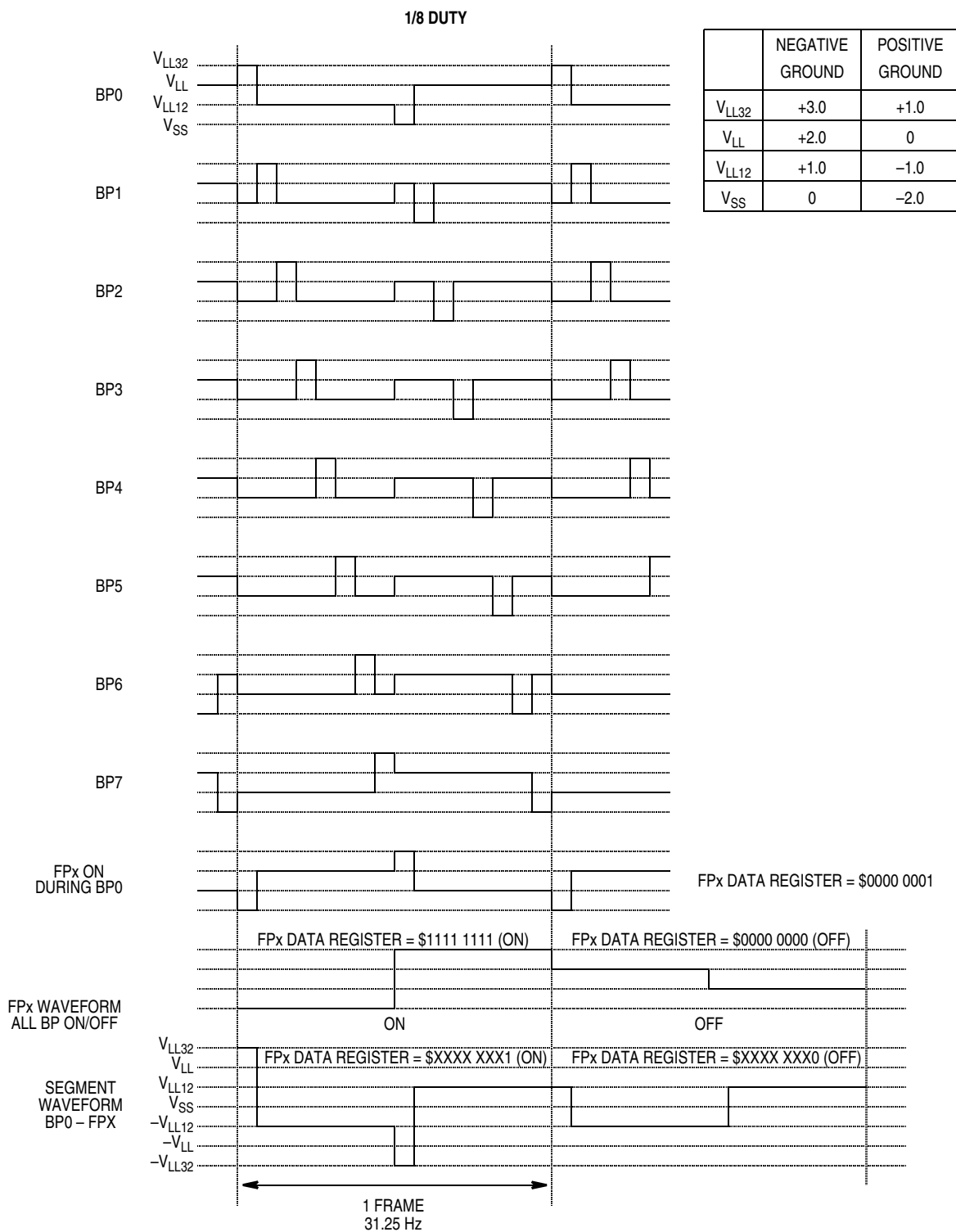

Figure 15-7. LCD Backplane Waveforms — 8 BP

15.5 Anti-Ghosting

The purpose of the anti-ghosting feature is to provide the user with the option to improve the LCD viewing angle at the expense of display contrast and increased power consumption. The level of improvement to the viewing angle as well as the amount of reduction in contrast depends entirely on the display used. The anti-ghosting is performed by taking all frontplane and backplane pins to V_{SS} potential for a short time ($\sim 16 \mu s$), while the internal muxing circuitry is transitioning. See Figure 15-8 for waveforms detailing the anti-ghosting pulses.

NOTE

The anti-ghosting pulses are not shown in the previous figures. Operating I_{DD} current approximately doubles with the use of the anti-ghosting function.

This feature generates radiated noise that has been shown to negatively impact RF (radio frequency) performance in some applications. RF testing should be completed before implementing anti-ghosting.

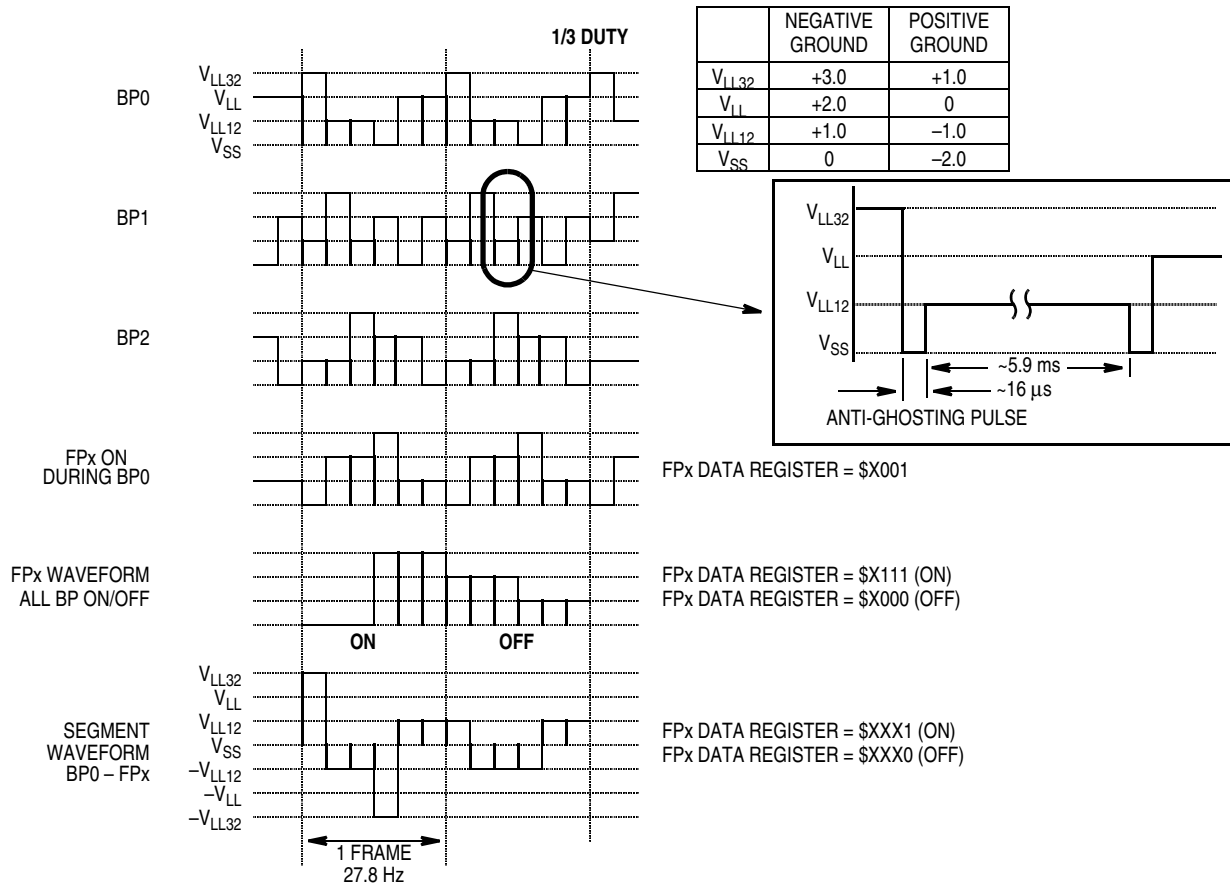

Figure 15-8. LCD Backplane Waveforms with Anti-Ghosting — 3 BP

15.6 Software Examples

This example shows a routine which loads the LCD data register with information for each frontplane.

```

*****
*
*       LCD Register Definitions
*
lcdcr  equ      $1a          LCD Control Register
lcdar  equ      $1b          LCD Address Register
lcddr  equ      $1c          LCD Data Register

        org      $8000
*
*       Load data into correct data registers
*
        ldx      #45          load correct number of data registers
datald stx      lcdar        point to the desired data register
        lda      data-1,x     fetch data
        sta      lcddr        store data
        decx     point to next register
        bne     datald        continue until all data registers full
*
*       Turn on display
*
        ldx      #$c0
        stx     lcdcr         configure w/ 8 BPs
        bra     *             loop here; hold display
*
*Message Table - Displays " DISPLAY " in nine 5x7 dot matrix characters
*(0 = off, 1 = on)
*   F F F F F   F F F F F   F F F F F   F F F F F   F F F F F   F F F F F   . . .
*   P P P P P   P P P P P   P P P P P   P P P P P   P P P P P   P P P P P   . . .
*   1 2 3 4 5   6 7 8 9 1   1 1 1 1 1   1 1 1 1 2   2 2 2 2 2   2 2 2 2 3   . . .
*                                     0 1 2 3 4 5   6 7 8 9 0   1 2 3 4 5   6 7 8 9 0   . . .
*
* BP0 0 0 0 0 0   1 1 1 0 0   0 1 1 1 0   0 1 1 1 1   1 1 1 1 0   1 0 0 0 0   . . .
* BP1 0 0 0 0 0   1 0 0 1 0   0 0 1 0 0   1 0 0 0 0   1 0 0 0 1   1 0 0 0 0   . . .
* BP2 0 0 0 0 0   1 0 0 0 1   0 0 1 0 0   1 0 0 0 0   1 0 0 0 1   1 0 0 0 0   . . .
* BP3 0 0 0 0 0   1 0 0 0 1   0 0 1 0 0   0 1 1 1 0   1 1 1 1 0   1 0 0 0 0   . . .
* BP4 0 0 0 0 0   1 0 0 0 1   0 0 1 0 0   0 0 0 0 1   1 0 0 0 0   1 0 0 0 0   . . .
* BP5 0 0 0 0 0   1 0 0 1 0   0 0 1 0 0   0 0 0 0 1   1 0 0 0 0   1 0 0 0 0   . . .
* BP6 0 0 0 0 0   1 1 1 0 0   0 1 1 1 0   1 1 1 1 0   1 0 0 0 0   1 1 1 1 1   . . .

data    equ      *
** **
        fcb      $00,$00,$00,$00,$00
**D**
        fcb      $7f,$41,$41,$22,$1c
**I**
        fcb      $00,$41,$7f,$41,$00
**S**
        fcb      $46,$49,$49,$49,$31
**P**
        fcb      $7f,$09,$09,$09,$06
**L**
        fcb      $7f,$40,$40,$40,$40
**A**
        fcb      $7e,$11,$11,$11,$7e
**Y**
        fcb      $07,$08,$70,$08,$07
** **
        fcb      $00,$00,$00,$00,$00
    
```

15.7 Power Supply Pins (V_{LL} , V_{LL12} , V_{LL32} , and V_{CP1} – V_{CP4})

These are power supply pins for the LCD voltage converter. When using the internal LCD voltage converter, the pins should be connected as shown in [Figure 15-9](#).

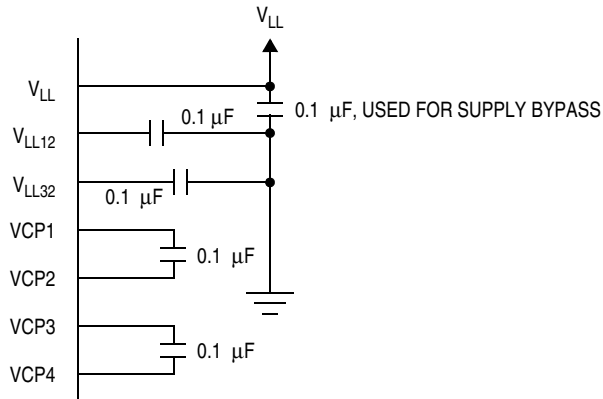

Figure 15-9. LCD Voltage Converter Connections

If an external voltage supply is used to power the LCD module, the appropriate voltages should be applied to the V_{LL} , V_{LL12} ($1/2 V_{LL}$) and V_{LL32} ($3/2 V_{LL}$) pins. V_{CP1} – V_{CP4} should be left floating.

Chapter 16

Timer Interface Module (TIM)

16.1 Introduction

This section describes the timer interface module (TIM). The TIM is a 4-channel timer that provides a timing reference with input capture, output compare, and pulse-width-modulation functions. [Figure 16-1](#) is a block diagram of the TIM.

NOTE

References to DMA and associated functions are only valid if the MCU has a DMA module. This MCU does not have the DMA function. Any DMA-related register bits should be left in their reset state for normal MCU operation.

16.2 Features

Features of the TIM include:

- Modular architecture
- Four input capture/output compare channels:
 - Rising-edge, falling-edge, or any-edge input capture trigger
 - Set, clear, or toggle output compare action
- Buffered and unbuffered pulse width modulation (PWM) signal generation
- Programmable TIM clock input:
 - Seven-frequency internal bus clock prescaler selection
 - External TIM clock input (4-MHz maximum frequency)
- Free-running or modulo up-count operation
- Toggle any channel pin on overflow
- Timer counter stop and reset bit

NOTE

Because no input or output pins are available for the timer module, the input capture functions are disabled. However, for the output compare function, when the counter reaches the value in the selected channel register, the timer can generate an interrupt to CPU. But it can't set, clear, or toggle the timer compare pin. Ignore all references to TCHx pins. See [16.4 Interrupts](#) for more information.

NOTE

The shaded boxes in [Figure 16-1](#) are not implemented in this module. All references to these blocks should be ignored. TCLK is a floating pin. Do not set the PS2–PS0 bits in the TIM status and control register to select TCLK input.

Timer Interface Module (TIM)

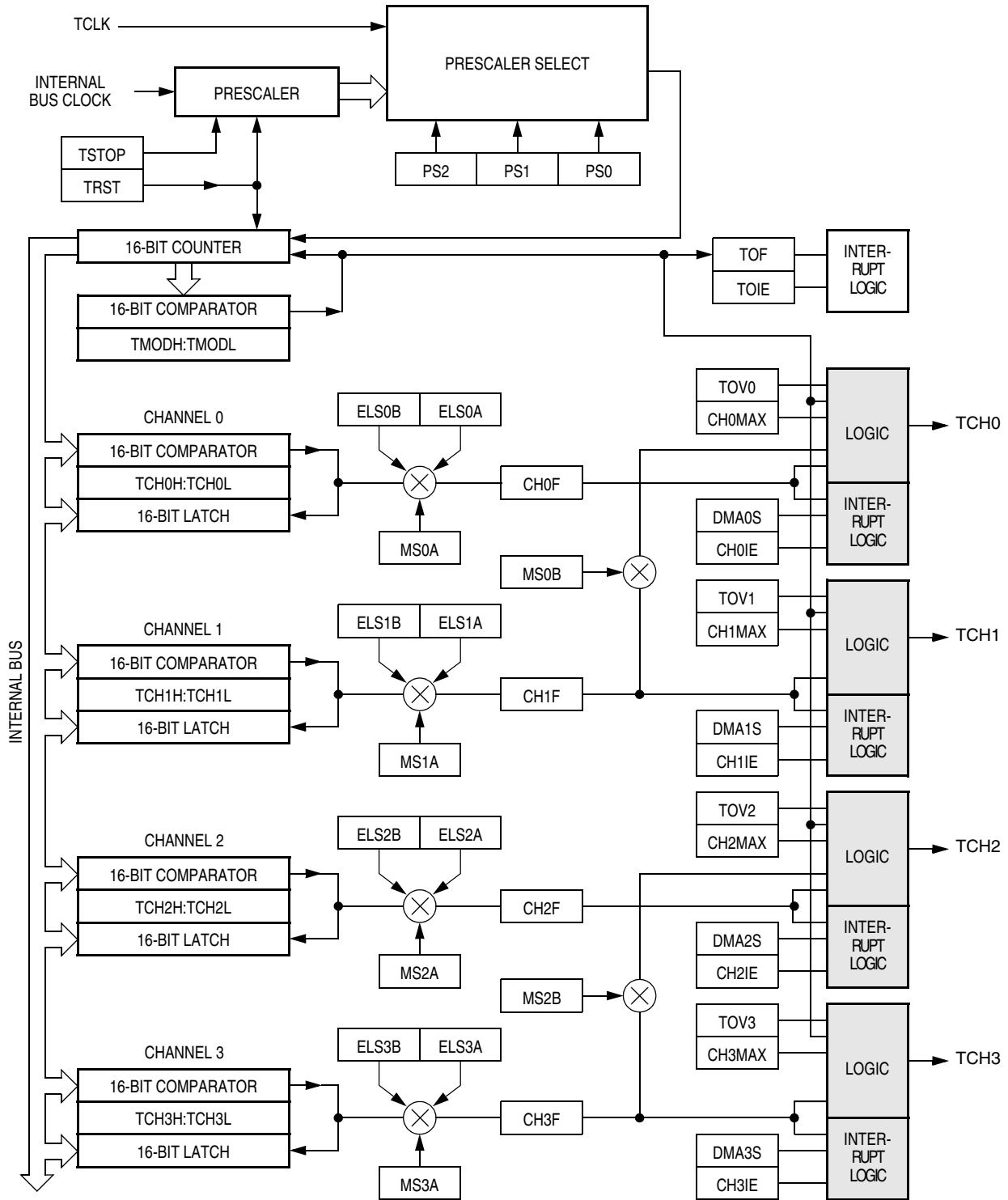

Figure 16-1. TIM Block Diagram

| Addr. | Register Name | Bit 7 | 6 | 5 | 4 | 3 | 2 | 1 | Bit 0 | |
|--------|--|--------|--------|--------|--------|--------|--------|--------|-------|--------|
| \$0020 | TIM Status and Control Register (TSC) | Read: | TOF | TOIE | TSTOP | 0 | 0 | PS2 | PS1 | PS0 |
| | | Write: | 0 | | | TRST | | | | |
| | | Reset: | 0 | 0 | 0 | 0 | 0 | 0 | 0 | 0 |
| \$0021 | Unimplemented | | | | | | | | | |
| \$0022 | TIM Counter Register High (TCNTH) | Read: | Bit 15 | Bit 14 | Bit 13 | Bit 12 | Bit 11 | Bit 10 | Bit 9 | Bit 8 |
| | | Write: | | | | | | | | |
| | | Reset: | 0 | 0 | 0 | 0 | 0 | 0 | 0 | 0 |
| \$0023 | TIM Counter Register Low (TCNTL) | Read: | Bit 7 | Bit 6 | Bit 5 | Bit 4 | Bit 3 | Bit 2 | Bit 1 | Bit 0 |
| | | Write: | | | | | | | | |
| | | Reset: | 0 | 0 | 0 | 0 | 0 | 0 | 0 | 0 |
| \$0024 | TIM Counter Modulo Register High (TMODH) | Read: | Bit 15 | Bit 14 | Bit 13 | Bit 12 | Bit 11 | Bit 10 | Bit 9 | Bit 8 |
| | | Write: | | | | | | | | |
| | | Reset: | 0 | 0 | 0 | 0 | 0 | 0 | 0 | 0 |
| \$0025 | TIM Counter Modulo Register Low (TMODL) | Read: | Bit 7 | Bit 6 | Bit 5 | Bit 4 | Bit 3 | Bit 2 | Bit 1 | Bit 0 |
| | | Write: | | | | | | | | |
| | | Reset: | 0 | 0 | 0 | 0 | 0 | 0 | 0 | 0 |
| \$0026 | TIM Channel 0 Status and Control Register (TSC0) | Read: | CH0F | CH0IE | MS0B | MS0A | ELS0B | ELS0A | TOV0 | CH0MAX |
| | | Write: | 0 | | | | | | | |
| | | Reset: | 0 | 0 | 0 | 0 | 0 | 0 | 0 | 0 |
| \$0027 | TIM Channel 0 Register High (TCH0H) | Read: | Bit 15 | Bit 14 | Bit 13 | Bit 12 | Bit 11 | Bit 10 | Bit 9 | Bit 8 |
| | | Write: | | | | | | | | |
| | | Reset: | 0 | 0 | 0 | 0 | 0 | 0 | 0 | 0 |
| \$0028 | TIM Channel 0 Register Low (TCH0L) | Read: | Bit 7 | Bit 6 | Bit 5 | Bit 4 | Bit 3 | Bit 2 | Bit 1 | Bit 0 |
| | | Write: | | | | | | | | |
| | | Reset: | 0 | 0 | 0 | 0 | 0 | 0 | 0 | 0 |
| \$0029 | TIM Channel 1 Status and Control Register (TSC1) | Read: | CH1F | CH1IE | 0 | MS1A | ELS1B | ELS1A | TOV1 | CH1MAX |
| | | Write: | 0 | | | | | | | |
| | | Reset: | 0 | 0 | 0 | 0 | 0 | 0 | 0 | 0 |
| \$002A | TIM Channel 1 Register High (TCH1H) | Read: | Bit 15 | Bit 14 | Bit 13 | Bit 12 | Bit 11 | Bit 10 | Bit 9 | Bit 8 |
| | | Write: | | | | | | | | |
| | | Reset: | 0 | 0 | 0 | 0 | 0 | 0 | 0 | 0 |
| \$002B | TIM Channel 1 Register Low (TCH1L) | Read: | Bit 7 | Bit 6 | Bit 5 | Bit 4 | Bit 3 | Bit 2 | Bit 1 | Bit 0 |
| | | Write: | | | | | | | | |
| | | Reset: | 0 | 0 | 0 | 0 | 0 | 0 | 0 | 0 |
| \$002C | TIM Channel 2 Status and Control Register (TSC2) | Read: | CH2F | CH2IE | MS2B | MS2A | ELS2B | ELS2A | TOV2 | CH2MAX |
| | | Write: | 0 | | | | | | | |
| | | Reset: | 0 | 0 | 0 | 0 | 0 | 0 | 0 | 0 |

= Unimplemented

Figure 16-2. TIM I/O Register Summary

Timer Interface Module (TIM)

| Addr. | Register Name | Bit 7 | 6 | 5 | 4 | 3 | 2 | 1 | Bit 0 | |
|--------|--|--------|--------|--------|--------|--------|--------|--------|-------|--------|
| \$002D | TIM Channel 2 Register High (TCH2H) | Read: | Bit 15 | Bit 14 | Bit 13 | Bit 12 | Bit 11 | Bit 10 | Bit 9 | Bit 8 |
| | | Write: | | | | | | | | |
| | | Reset: | 0 | 0 | 0 | 0 | 0 | 0 | 0 | 0 |
| \$002E | TIM Channel 2 Register Low (TCH2L) | Read: | Bit 7 | Bit 6 | Bit 5 | Bit 4 | Bit 3 | Bit 2 | Bit 1 | Bit 0 |
| | | Write: | | | | | | | | |
| | | Reset: | 0 | 0 | 0 | 0 | 0 | 0 | 0 | 0 |
| \$002F | TIM Channel 3 Status and Control Register (TSC3) | Read: | CH3F | CH3IE | 0 | MS3A | ELS3B | ELS3A | TOV3 | CH3MAX |
| | | Write: | 0 | | | | | | | |
| | | Reset: | 0 | 0 | 0 | 0 | 0 | 0 | 0 | 0 |
| \$0030 | TIM Channel 3 Register High (TCH3H) | Read: | Bit 15 | Bit 14 | Bit 13 | Bit 12 | Bit 11 | Bit 10 | Bit 9 | Bit 8 |
| | | Write: | | | | | | | | |
| | | Reset: | 0 | 0 | 0 | 0 | 0 | 0 | 0 | 0 |
| \$0031 | TIM Channel 3 Register Low (TCH3L) | Read: | Bit 7 | Bit 6 | Bit 5 | Bit 4 | Bit 3 | Bit 2 | Bit 1 | Bit 0 |
| | | Write: | | | | | | | | |
| | | Reset: | 0 | 0 | 0 | 0 | 0 | 0 | 0 | 0 |

= Unimplemented

Figure 16-2. TIM I/O Register Summary (Continued)

16.3 Functional Description

Figure 16-1 shows the structure of the TIM. The central component of the TIM is the 16-bit timer counter that can operate as a free-running counter or a modulo up-counter. The timer counter provides the timing reference for the input capture and output compare functions. The timer counter modulo registers, TMODH and TMODL, control the modulo value of the timer counter. Software can read the timer counter value at any time without affecting the counting sequence.

The four TIM channels are programmable independently as input capture or output compare channels.

16.3.1 Timer Counter Prescaler

The TIM clock source can be one of the seven prescaler outputs or the TIM clock pin, TCLK. The prescaler generates seven clock rates from the internal bus clock. The prescaler select bits, PS2–PS0, in the timer status and control register select the TIM clock source.

NOTE

This device does not have a TCLK pin.

16.3.2 Input Capture

With the input capture function, the TIM can capture the time at which an external event occurs. When an active edge occurs on the pin of an input capture channel, the TIM latches the contents of the timer counter into the timer channel registers, TCHxH and TCHxL. The polarity of the active edge is programmable. Input capture latency can be up to three bus clock cycles. Input captures can generate TIM CPU interrupt requests.

NOTE

This device does not have input capture functionality.

16.3.3 Output Compare

With the output compare function, the TIM can generate a periodic pulse with a programmable polarity, duration, and frequency. When the counter reaches the value in the registers of an output compare channel, the TIM can set, clear, or toggle the channel pin. Output compares can generate TIM CPU interrupt requests or TIM DMA service requests.

NOTE

This device does not have output compare pins.

16.3.3.1 Unbuffered Output Compare

Any output compare channel can generate unbuffered output compare pulses as described in [16.3.3 Output Compare](#). The pulses are unbuffered because changing the output compare value requires writing the new value over the old value currently in the timer channel registers.

An unsynchronized write to the timer channel registers to change an output compare value could cause incorrect operation for up to two counter overflow periods. For example, writing a new value before the counter reaches the old value but after the counter reaches the new value prevents any compare during that counter overflow period. Also, using a timer overflow interrupt routine to write a new, smaller output compare value may cause the compare to be missed. The timer may pass the new value before it is written.

Use these methods to synchronize unbuffered changes in the output compare value on channel x:

- When changing to a smaller value, enable channel x output compare interrupts and write the new value in the output compare interrupt routine. The output compare interrupt occurs at the end of the current output compare pulse. The interrupt routine has until the end of the counter overflow period to write the new value.
- When changing to a larger output compare value, enable channel x timer overflow interrupts and write the new value in the timer overflow interrupt routine. The timer overflow interrupt occurs at the end of the current counter overflow period. Writing a larger value in an output compare interrupt routine (at the end of the current pulse) could cause two output compares to occur in the same counter overflow period.

16.3.3.2 Buffered Output Compare

Channels 0 and 1 can be linked to form a buffered output compare channel whose output appears on the TCH0 pin. The timer channel registers of the linked pair alternately control the output.

Setting the MS0B bit in timer channel 0 status and control register (TSC0) links channel 0 and channel 1. The output compare value in the timer channel 0 registers initially controls the output on the TCH0 pin. Writing to the timer channel 1 registers enables the timer channel 1 registers to synchronously control the output after the timer overflows. At each subsequent overflow, the timer channel registers (0 or 1) that control the output are the ones written to last. TSC0 controls and monitors the buffered output compare function, and timer channel 1 status and control register (TSC1) is unused. While the MS0B bit is set, the channel 1 pin, TCH1, is available as a general-purpose I/O pin.

Channels 2 and 3 can be linked to form a buffered output compare channel whose output appears on the TCH2 pin. The timer channel registers of the linked pair alternately control the output.

Setting the MS2B bit in timer channel 2 status and control register (TSC2) links channel 2 and channel 3. The output compare value in the timer channel 2 registers initially controls the output on the TCH2 pin. Writing to the timer channel 3 registers enables the timer channel 3 registers to synchronously control the

Timer Interface Module (TIM)

output after the timer overflows. At each subsequent overflow, the timer channel registers (2 or 3) that control the output are the ones written to last. TSC2 controls and monitors the buffered output compare function, and timer channel 3 status and control register (TSC3) is unused. In buffered output compare operation, do not write new output compare values to the currently active channel registers. Writing to the active channel registers is the same as generating unbuffered output compares.

16.3.4 Pulse-Width Modulation (PWM)

By using the toggle-on-overflow feature with an output compare channel, the TIM can generate a PWM signal. The value in the timer counter modulo registers determines the period of the PWM signal. The channel pin toggles when the counter reaches the value in the timer counter modulo registers. The time between overflows is the period of the PWM signal.

As [Figure 16-3](#) shows, the output compare value in the timer channel registers determines the pulse width of the PWM signal. The time between overflow and output compare is the pulse width. Program the TIM to clear the channel pin on output compare if the state of the PWM pulse is logic 1. Program the TIM to set the pin if the state of the PWM pulse is logic 0.

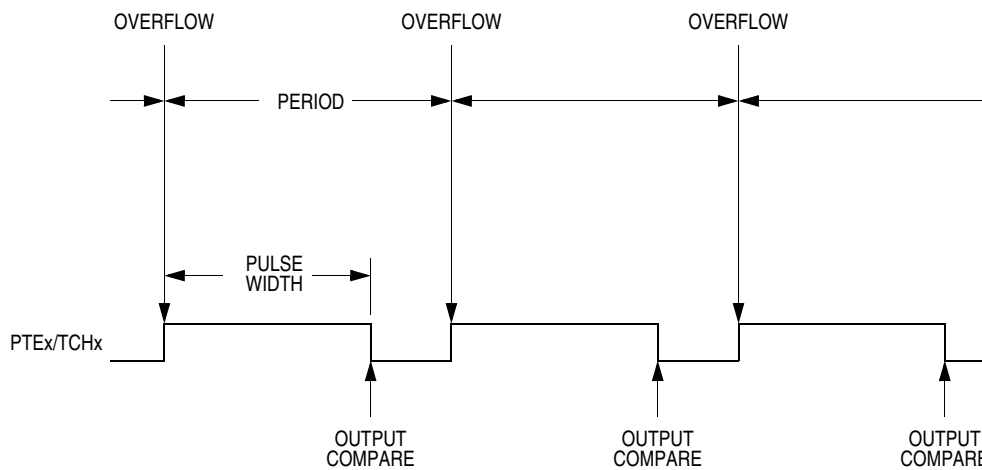

Figure 16-3. PWM Period and Pulse Width

The value in the timer counter modulo registers and the selected prescaler output determine the frequency of the PWM output. The frequency of an 8-bit PWM signal is variable in 256 increments. Writing \$00FF (255) to the timer counter modulo registers produces a PWM period of 256 times the internal bus clock period.

The value in the timer channel registers determines the pulse width of the PWM output. The pulse width of an 8-bit PWM signal is variable in 256 increments. Writing \$0080 (128) to the timer channel registers produces a duty cycle of 128/256 or 50%.

NOTE

This device does not have channel pins for PWM.

16.3.4.1 Unbuffered PWM Signal Generation

Any output compare channel can generate unbuffered PWM pulses as described in [16.3.4 Pulse-Width Modulation \(PWM\)](#). The pulses are unbuffered because changing the pulse width requires writing the new pulse width value over the old value currently in the timer channel registers.

An unsynchronized write to the timer channel registers to change a pulse width value could cause incorrect operation for up to two PWM periods. For example, writing a new value before the counter reaches the old value but after the counter reaches the new value prevents any compare during that PWM period. Also, using a timer overflow interrupt routine to write a new, smaller pulse width value may cause the compare to be missed. The timer may pass the new value before it is written.

Use these methods to synchronize unbuffered changes in the PWM pulse width on channel x:

- When changing to a shorter pulse width, enable channel x output compare interrupts and write the new value in the output compare interrupt routine. The output compare interrupt occurs at the end of the current pulse. The interrupt routine has until the end of the PWM period to write the new value.
- When changing to a longer pulse width, enable channel x timer overflow interrupts and write the new value in the timer overflow interrupt routine. The timer overflow interrupt occurs at the end of the current PWM period. Writing a larger value in an output compare interrupt routine (at the end of the current pulse) could cause two output compares to occur in the same PWM period.

NOTE

In PWM signal generation, do not program the PWM channel to toggle on output compare. Toggling on output compare prevents reliable 0% duty cycle generation and removes the ability of the channel to self-correct in the event of software error or noise. Toggling on output compare also can cause incorrect PWM signal generation when changing the PWM pulse width to a new, much larger value.

16.3.4.2 Buffered PWM Signal Generation

Channels 0 and 1 can be linked to form a buffered PWM channel whose output appears on the TCH0 pin. The timer channel registers of the linked pair alternately control the pulse width of the output.

Setting the MS0B bit in timer channel 0 status and control register (TSC0) links channel 0 and channel 1. The timer channel 0 registers initially control the pulse width on the TCH0 pin. Writing to the timer channel 1 registers enables the timer channel 1 registers to synchronously control the pulse width at the beginning of the next PWM period. At each subsequent overflow, the timer channel registers (0 or 1) that control the pulse width are the ones written to last. TSC0 controls and monitors the buffered PWM function, and timer channel 1 status and control register (TSC1) is unused. While the MS0B bit is set, the channel 1 pin, TCH1, is available as a general-purpose I/O pin if the timer pad is shared with the I/O pad.

Channels 2 and 3 can be linked to form a buffered PWM channel whose output appears on the TCH2 pin. The timer channel registers of the linked pair alternately control the pulse width of the output.

Setting the MS2B bit in timer channel 2 status and control register (TSC2) links channel 2 and channel 3. The timer channel 2 registers initially control the pulse width on the TCH2 pin. Writing to the timer channel 3 registers enables the timer channel 3 registers to synchronously control the pulse width at the beginning of the next PWM period. At each subsequent overflow, the timer channel registers (2 or 3) that control the pulse width are the ones written to last. TSC2 controls and monitors the buffered PWM function, and timer channel 3 status and control register (TSC3) is unused.

NOTE

In buffered PWM signal generation, do not write new pulse width values to the currently active channel registers. Writing to the active channel registers is the same as generating unbuffered PWM signals.

16.3.4.3 PWM Initialization

To ensure correct operation when generating unbuffered or buffered PWM signals, use this initialization procedure:

1. In the timer status and control register (TSC):
 - a. Stop the timer counter by setting the timer stop bit, TSTOP.
 - b. Reset the timer counter by setting the timer reset bit, TRST.
2. In the timer counter modulo registers (TMODH and TMODL), write the value for the required PWM period.
3. In the timer channel x registers (TCHxH and TCHxL), write the value for the required pulse width.
4. In timer channel x status and control register (TSCx):
 - a. Write 0:1 (for unbuffered output compare or PWM signals) or 1:0 (for buffered output compare or PWM signals) to the mode select bits, MSxB:MSxA. (See [Table 16-2](#).)
 - b. Write 1 to the toggle on overflow bit, TOVx.
 - c. Write 1:0 (to clear output on compare) or 1:1 (to set output on compare) to the edge/level select bits, ELSxB and ELSxA. The output action on compare must force the output to the complement of the pulse width level. (See [Table 16-2](#).)

NOTE

In PWM signal generation, do not program the PWM channel to toggle on output compare. Toggling on output compare prevents reliable 0% duty cycle generation and removes the ability of the channel to self-correct in the event of software error or noise. Toggling on output compare can also cause incorrect PWM signal generation when changing the PWM pulse width to a new, much larger value.

5. In the timer status control register (TSC), clear the timer stop bit, TSTOP.

Setting MS0B links channels 0 and 1 and configures them for buffered PWM operation. The timer channel 0 registers (TCH0H and TCH0L) initially control the buffered PWM output. Timer status control register 0 (TSCR0) controls and monitors the PWM signal from the linked channels. MS0B takes priority over MS0A.

Setting MS2B links channels 2 and 3 and configures them for buffered PWM operation. The timer channel 2 registers (TCH2H and TCH2L) initially control the PWM output. Timer status control register 2 (TSCR2) controls and monitors the PWM signal from the linked channels. MS2B takes priority over MS2A.

Clearing the toggle on overflow bit, TOVx, inhibits output toggles on timer overflows. Subsequent output compares try to force the output to a state it is already in and have no effect. The result is a 0% duty cycle output.

Setting the CHxMAX bit generates a 100% duty cycle output. (See [16.8.4 Timer Channel Status and Control Registers](#).)

16.4 Interrupts

The TIM sources can generate these interrupt requests:

- TIM overflow flag (TOF) — TOF is set when the TIM counter value matches the value in the TIM counter modulo registers. The TIM overflow interrupt enable bit, TOIE, enables the TOF flag to generate TIM overflow CPU interrupt requests. TOF and TOIE are in the TIM status and control register
- TIM channel flags (CH3F–CH0F) — CHxF is set when an input capture or output compare occurs on channel x. The channel x interrupt enable bit, CHxIE, enables the CHxF flag to generate TIM channel x CPU interrupt requests. CHxF and CHxIE are in the TIM channel x status and control register.

16.5 Low-Power Modes

The WAIT and STOP instructions put the MCU in low power- consumption standby modes.

16.5.1 Wait Mode

The TIM remains active after the execution of a WAIT instruction. Any enabled CPU interrupt request from the TIM can bring the MCU out of wait mode. If the TIM is not required to bring the MCU out of wait mode, reduce power consumption by stopping the TIM before executing the WAIT instruction.

16.5.2 Stop Mode

The TIM is inactive after the execution of a STOP instruction. The STOP instruction does not affect register conditions or the state of the timer counter. Timer operation resumes when the MCU exits stop mode after an external interrupt.

NOTE

This device does not function in stop mode.

16.6 TIM During Break Interrupts

A break interrupt stops the timer counter.

The system integration module (SIM) controls whether status bits in other modules can be cleared during the break state. The BCFE bit in the SIM break flag control register (SBFCR) enables software to clear status bits during the break state. (See [9.4.1 Break Status and Control Register](#).)

To allow software to clear status bits during a break interrupt, write a logic 1 to the BCFE bit. If a status bit is cleared during the break state, it remains cleared when the MCU exits the break state.

To protect status bits during the break state, write a logic 0 to the BCFE bit. With BCFE at logic 0 (its default state), software can read and write I/O registers during the break state without affecting status bits. Some status bits have a 2-step read/write clearing procedure. If software does the first step on such a bit before the break, the bit cannot change during the break state as long as BCFE is at logic 0. After the break, doing the second step clears the status bit.

16.7 I/O Signals

TCLK is an external clock input to the timer prescaler. The four timer channel I/O pins are TCH0, TCH1, TCH2, and TCH3.

NOTE

This device does not have external timer pins.

16.7.1 TIM Clock Pin (TCLK)

TCLK is an external clock input that can be the clock source for the timer counter instead of the prescaled internal bus clock. Select the TCLK input by writing logic 1s to the three prescaler select bits, PS2–PS0. (See [16.8.1 Timer Status and Control Register](#).) The minimum TCLK pulse width, $TCLK_{L_{MIN}}$ or $TCLK_{H_{MIN}}$, is:

$$\frac{1}{\text{bus frequency}} + t_{SU}$$

The maximum TCLK frequency is:

$$\text{bus frequency} \div 2$$

16.7.2 Timer Channel I/O Pins (TCH0–TCH3)

Each channel I/O pin is programmable independently as an input capture pin or an output compare pin. TCH0 and TCH2 can be configured as buffered output compare or buffered PWM pins.

16.8 I/O Registers

These I/O registers control and monitor operation of the TIM:

- Timer status and control register (TSC)
- Timer DMA select register (TDMA)
- Timer control registers (TCNTH and TCNTL)
- Timer counter modulo registers (TMODH and TMODL)
- Timer channel status and control registers (TSC0, TSC1, TSC2, and TSC3)
- Timer channel registers (TCH0H, TCH0L, TCH1H, TCH1L, TCH2H, TCH2L, TCH3H, and TCH3L)

16.8.1 Timer Status and Control Register

The timer status and control register (TSC):

- Enables timer overflow interrupts
- Flags timer overflows
- Stops the timer counter
- Resets the timer counter and prescaler
- Prescales the timer counter clock

Address: \$0020

| | Bit 7 | 6 | 5 | 4 | 3 | 2 | 1 | Bit 0 |
|--------|-------|------|-------|------|---|-----|-----|-------|
| Read: | TOF | TOIE | TSTOP | 0 | 0 | PS2 | PS1 | PS0 |
| Write: | 0 | | | TRST | | | | |
| Reset: | 0 | 0 | 0 | 0 | 0 | 0 | 0 | 0 |

 = Unimplemented

Figure 16-4. Timer Status and Control Register (TSC)

TOF — Timer overflow flag bit

This read/write flag is set when the timer counter reaches the modulo value programmed in the timer counter modulo registers. Clear TOF by reading the timer status and control register when TOF is set and then writing a logic 0 to TOF. If another timer overflow occurs before the clearing sequence is complete, then writing logic 0 to TOF has no effect. Therefore, a TOF interrupt request cannot be lost due to inadvertent clearing of TOF. Reset clears the TOF bit. Writing a logic 1 to TOF has no effect.

- 1 = Timer counter has reached modulo value.
- 0 = Timer counter has not reached modulo value.

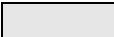
TOIE — Timer overflow interrupt enable bit

This read/write bit enables timer overflow interrupts when the TOF bit becomes set. Reset clears the TOIE bit.

- 1 = Timer overflow interrupts enabled
- 0 = Timer overflow interrupts disabled

TSTOP — Timer stop bit

This read/write bit stops the timer counter. Counting resumes when TSTOP is cleared. Reset sets the TSTOP bit, stopping the timer counter until software clears the TSTOP bit.

- 1 = Timer counter stopped
- 0 = Timer counter active

NOTE

Do not set the TSTOP bit before entering wait mode if the TIM is required to exit wait mode.

TRST — Timer reset bit

Setting this write-only bit resets the timer counter and the timer prescaler. Setting TRST has no effect on any other registers. Counting resumes from \$0000. TRST is cleared automatically after the timer counter is reset and always reads as logic 0. Reset clears the TRST bit.

- 1 = Prescaler and timer counter cleared
- 0 = No effect

NOTE

Setting the TSTOP and TRST bits simultaneously stops the timer counter at a value of \$0000.

PS[2:0] — Prescaler select bits

These read/write bits select either the PTE3/TCLK pin or one of the seven prescaler outputs as the input to the timer counter as

Table 16-1 shows. Reset clears the PS2–PS0 bits.

NOTE

TCLK is a floating input pin. Do not select PS2–PS0 = 111.

Table 16-1. Prescaler Selection

| PS2–PS0 | TIM clock source |
|---------|-------------------------|
| 000 | Internal bus clock |
| 001 | Internal bus clock ÷ 2 |
| 010 | Internal bus clock ÷ 4 |
| 011 | Internal bus clock ÷ 8 |
| 100 | Internal bus clock ÷ 16 |
| 101 | Internal bus clock ÷ 32 |
| 110 | Internal bus clock ÷ 64 |
| 111 | PTE3/TCLK |

16.8.2 Timer Counter Registers

The two read-only timer counter registers contain the high and low bytes of the value in the timer counter. Reading the high byte (TCNTH) latches the contents of the low byte (TCNTL). Subsequent reads of TCNTH do not affect the latched TCNTL value until TCNTL is read. Reset clears the timer counter registers.

Setting the timer reset bit (TRST) also clears the timer counter registers.

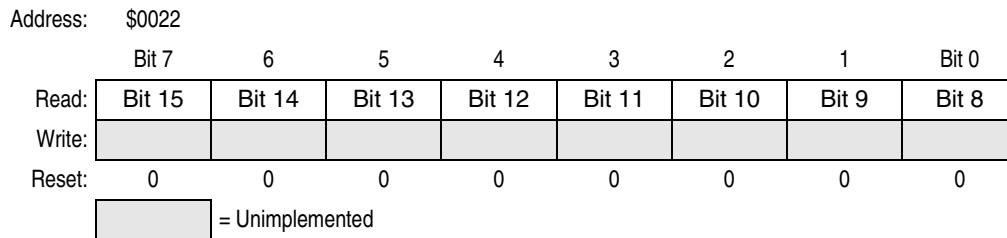

Figure 16-5. Timer Counter Register High (TCNTH)

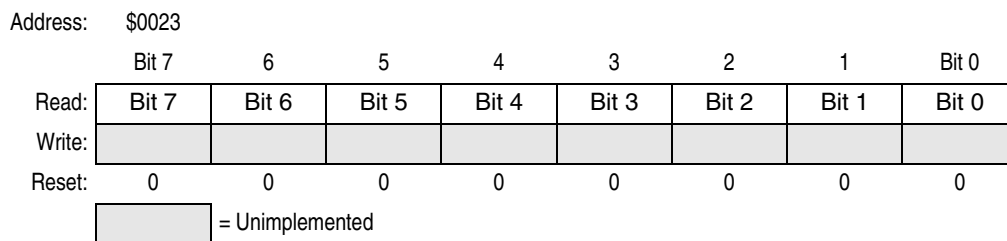

Figure 16-6. Timer Counter Register Low (TCNTL)

16.8.3 Timer Modulo Registers

The read/write timer modulo registers contain the modulo value for the timer counter. When the timer counter reaches the modulo value, the overflow flag (TOF) becomes set, and the timer counter resumes counting from \$0000 at the next clock. The TOF bit and overflow interrupts are inhibited after a write to the high byte (TMODH) until the low byte (TMODL) is written. Reset sets the timer modulo registers.

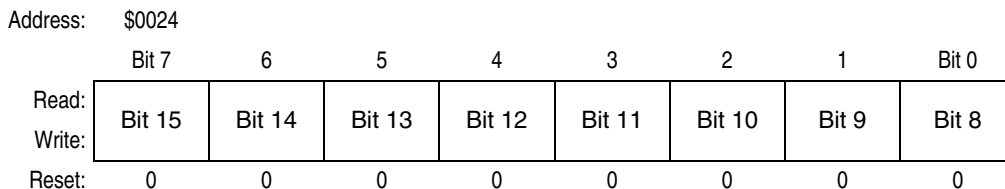

Figure 16-7. Timer Modulo Register High (TMODH)

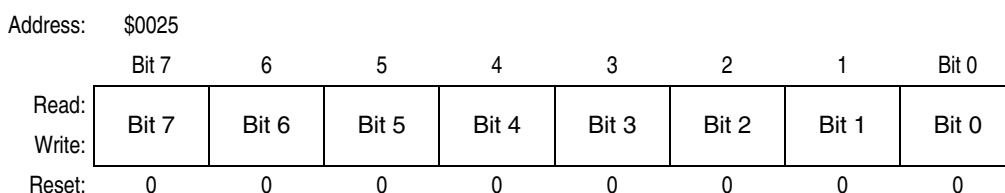

Figure 16-8. Timer Modulo Register Low (TMODL)

NOTE

Reset the timer counter before writing to the timer modulo registers.

16.8.4 Timer Channel Status and Control Registers

Each of the timer channel status and control registers:

- Flags input captures and output compares
- Enables input capture and output compare interrupts
- Selects input capture, output compare, or PWM operation
- Selects high, low, or toggling output on output compare
- Selects rising edge, falling edge, or any edge as the active input capture trigger
- Selects output toggling on timer overflow
- Selects 100% PWM duty cycle

Timer Interface Module (TIM)

Address: \$0026

| | Bit 7 | 6 | 5 | 4 | 3 | 2 | 1 | Bit 0 |
|--------|-------|-------|------|------|-------|-------|------|--------|
| Read: | CH0F | CH0IE | MS0B | MS0A | ELS0B | ELS0A | TOV0 | CH0MAX |
| Write: | 0 | | | | | | | |
| Reset: | 0 | 0 | 0 | 0 | 0 | 0 | 0 | 0 |

Figure 16-9. Timer Channel 0 Status and Control Register (TSC0)

Address: \$0029

| | Bit 7 | 6 | 5 | 4 | 3 | 2 | 1 | Bit 0 |
|--------|-------|-------|---|------|-------|-------|------|--------|
| Read: | CH1F | CH1IE | 0 | MS1A | ELS1B | ELS1A | TOV1 | CH1MAX |
| Write: | 0 | | | | | | | |
| Reset: | 0 | 0 | 0 | 0 | 0 | 0 | 0 | 0 |

= Unimplemented

Figure 16-10. Timer Channel 1 Status and Control Register (TSC1)

Address: \$002C

| | Bit 7 | 6 | 5 | 4 | 3 | 2 | 1 | Bit 0 |
|--------|-------|-------|------|------|-------|-------|------|--------|
| Read: | CH2F | CH2IE | MS2B | MS2A | ELS2B | ELS2A | TOV2 | CH2MAX |
| Write: | 0 | | | | | | | |
| Reset: | 0 | 0 | 0 | 0 | 0 | 0 | 0 | 0 |

Figure 16-11. Timer Channel 2 Status and Control Register (TSC2)

Address: \$002F

| | Bit 7 | 6 | 5 | 4 | 3 | 2 | 1 | Bit 0 |
|--------|-------|-------|---|------|-------|-------|------|--------|
| Read: | CH3F | CH3IE | 0 | MS3A | ELS3B | ELS3A | TOV3 | CH3MAX |
| Write: | 0 | | | | | | | |
| Reset: | 0 | 0 | 0 | 0 | 0 | 0 | 0 | 0 |

= Unimplemented

Figure 16-12. Timer Channel 3 Status and Control Register (TSC3)

CHxF— Channel x flag bit

When channel x is an input capture channel, this read/write bit is set when an active edge occurs on the channel x pin. When channel x is an output compare channel, CHxF is set when the value in the timer counter registers matches the value in the timer channel x registers.

When TIM CPU interrupt requests are enabled (CHxIE:DMAxS = 1:0), clear CHxF by reading timer channel x status and control register with CHxF set and then writing a logic 0 to CHxF. If another interrupt request occurs before the clearing sequence is complete, then writing logic 0 to CHxF has no effect. Therefore, an interrupt request cannot be lost due to inadvertent clearing of CHxF.

When TIM DMA service requests are enabled (CHxIE:DMAxS = 1:1), clear CHxF by reading or writing to the low byte of the timer channel x registers (TCHxL).

Reset clears the CHxF bit. Writing a logic 1 to CHxF has no effect.

- 1 = Input capture or output compare on channel x
- 0 = No input capture or output compare on channel x

CHxIE — Channel x interrupt enable bit

This read/write bit enables TIM CPU interrupt requests on channel x. The DMAxS bit in the timer DMA select register selects channel x TIM DMA service requests or TIM CPU interrupt requests.

NOTE

TIM DMA service requests cannot be used in buffered PWM mode. In buffered PWM mode, disable TIM DMA service requests by clearing the DMAxS bit in the timer DMA select register.

Reset clears the CHxIE bit.

- 1 = Channel x CPU interrupt requests and DMA service requests enabled
- 0 = Channel x CPU interrupt requests and DMA service requests disabled

NOTE

Reading the high byte of the timer channel x registers (TCHxH) inhibits the CHxF flag until the low byte (TCHxL) is read.

MSxB — Mode select bit B

This read/write bit selects buffered output compare/PWM operation. MSxB exists only in the timer channel 0 and timer channel 2 status and control registers. Setting MS0B disables the channel 1 status and control register. Setting MS2B disables the channel 3 status and control register.

Reset clears the MSxB bit.

- 1 = Buffered output compare/PWM operation enabled
- 0 = Buffered output compare/PWM operation disabled

MSxA — Mode select bit A

When ELSxB:A ≠ 00, this read/write bit selects either input capture operation or unbuffered output compare/PWM operation.

(See [Table 16-2](#).)

- 1 = Unbuffered output compare/PWM operation
- 0 = Input capture operation

When ELSxB:A = 00, this read/write bit selects the initial output level of the TCHx pin. (See [Table 16-2](#).) Reset clears the MSxA bit.

- 1 = Initial output level low
- 0 = Initial output level high

NOTE

Before changing a channel function by writing to the MSxB or MSxA bit, set the TSTOP and TRST bits in the timer status and control register (TSC).

ELSxB and ELSxA — Edge/level select bits

When channel x is an input capture channel, these read/write bits control the active edge-sensing logic on channel x.

When channel x is an output compare channel, ELSxB and ELSxA control the channel x output behavior when an output compare occurs.

When ELSxB and ELSxA are both clear, channel x is not connected to port E, and pin TCHx is available as a general-purpose I/O pin. [Table 16-2](#) shows how ELSxB and ELSxA work. Reset clears the ELSxB and ELSxA bits.

Table 16-2. Mode, Edge, and Level Selection

| MSxB:MSxA | ELSxB:ELSxA | Mode | Configuration |
|-----------|-------------|---|--|
| X0 | 00 | Output preset | Set initial output level high |
| X1 | 00 | | Set initial output level low |
| XX | 00 | — | TCHx pin under port control |
| 00 | 01 | Input capture | Capture on rising edge only |
| 00 | 10 | | Capture on falling edge only |
| 00 | 11 | | Capture on rising or falling edge |
| XX | 00 | — | TCHx pin under port control; initial output low |
| 01 | 01 | Output compare or PWM | Toggle output on compare |
| 01 | 10 | | Clear output on compare |
| 01 | 11 | | Set output on compare |
| XX | 00 | — | TCHx pin under port control ⁽¹⁾ |
| 1X | 01 | Buffered output compare or buffered PWM | Toggle output on compare |
| 1X | 10 | | Clear output on compare |
| 1X | 11 | | Set output on compare |

1. Initial output high if MSxA = 0. Initial output low if MSxA = 1.

NOTE

Before enabling a timer channel register for input capture operation, make sure that the TCHx pin is stable for at least two bus clocks.

TOVx — Toggle on overflow bit

When channel x is an output compare channel, this read/write bit controls the behavior of the channel x output when the timer counter overflows. When channel x is an input capture channel, TOVx has no effect. Reset clears the TOVx bit.

- 1 = Channel x pin toggles on timer counter overflow.
- 0 = Channel x pin does not toggle on timer counter overflow.

NOTE

When TOVx is set, a timer counter overflow takes precedence over a channel x output compare if both occur at the same time.

Reading the high byte of the timer channel x registers prevents the channel x pin from toggling until the low byte is read.

CHxMAX — Channel x maximum (100%) PWM duty cycle bit

This read/write bit forces the duty cycle of buffered and unbuffered PWM signals to 100%. As [Figure 16-13](#) shows, the CHxMAX bit takes effect in the cycle after it is set or cleared. The output stays at the 100% duty cycle level until the cycle after CHxMAX is cleared.

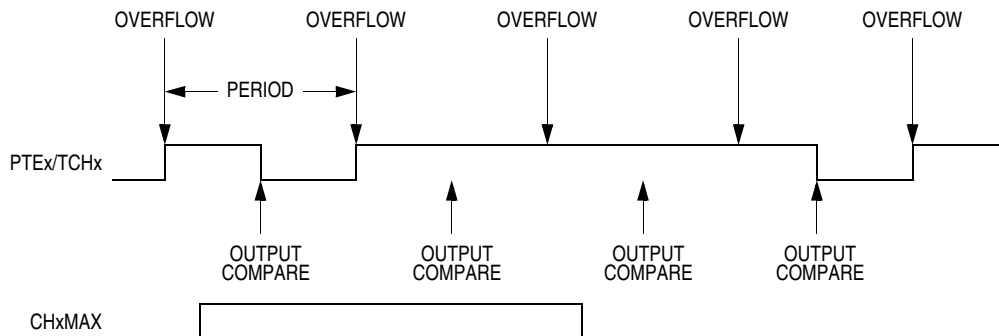

Figure 16-13. CHxMAX Latency

16.8.5 Timer Channel Registers

The timer channel registers (TCH0H/L–TCH3H/L) are read/write registers containing the captured timer counter value of the input capture function or the output compare value of the output compare function. The state of the timer channel registers after reset is unknown.

In input capture mode ($MSxB:MSxA = 0:0$), reading the high byte of the timer channel x registers (TCHxH) inhibits input captures until the low byte (TCHxL) is read.

In output compare mode ($MSxB:MSxA \neq 0:0$), writing to the high byte of the timer channel x registers (TCHxH) inhibits output compares until the low byte (TCHxL) is written.

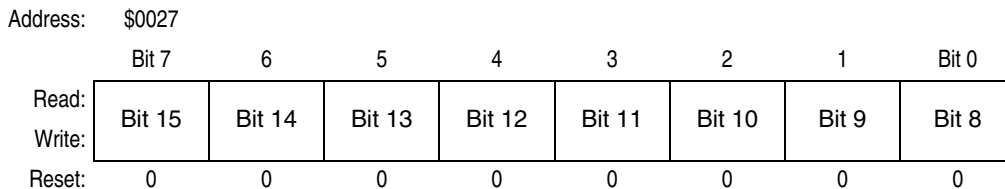

Figure 16-14. Timer Channel 0 Register High (TCH0H)

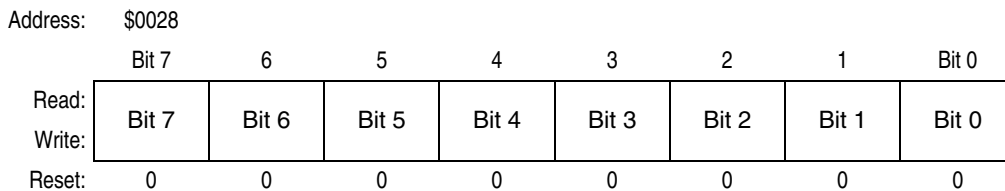

Figure 16-15. Timer Channel 0 Register Low (TCH0L)

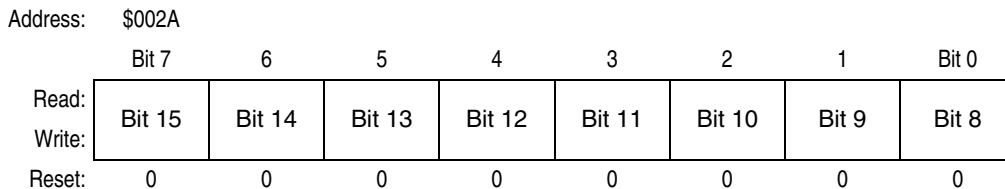

Figure 16-16. Timer Channel 1 Register High (TCH1H)

Timer Interface Module (TIM)

Address: \$002B

| | | | | | | | | |
|--------|-------|-------|-------|-------|-------|-------|-------|-------|
| | Bit 7 | 6 | 5 | 4 | 3 | 2 | 1 | Bit 0 |
| Read: | Bit 7 | Bit 6 | Bit 5 | Bit 4 | Bit 3 | Bit 2 | Bit 1 | Bit 0 |
| Write: | Bit 7 | Bit 6 | Bit 5 | Bit 4 | Bit 3 | Bit 2 | Bit 1 | Bit 0 |
| Reset: | 0 | 0 | 0 | 0 | 0 | 0 | 0 | 0 |

Figure 16-17. Timer Channel 1 Register Low (TCH1L)

Address: \$002D

| | | | | | | | | |
|--------|--------|--------|--------|--------|--------|--------|-------|-------|
| | Bit 7 | 6 | 5 | 4 | 3 | 2 | 1 | Bit 0 |
| Read: | Bit 15 | Bit 14 | Bit 13 | Bit 12 | Bit 11 | Bit 10 | Bit 9 | Bit 8 |
| Write: | Bit 15 | Bit 14 | Bit 13 | Bit 12 | Bit 11 | Bit 10 | Bit 9 | Bit 8 |
| Reset: | 0 | 0 | 0 | 0 | 0 | 0 | 0 | 0 |

Figure 16-18. Timer Channel 2 Register High (TCH2H)

Address: \$002E

| | | | | | | | | |
|--------|-------|-------|-------|-------|-------|-------|-------|-------|
| | Bit 7 | 6 | 5 | 4 | 3 | 2 | 1 | Bit 0 |
| Read: | Bit 7 | Bit 6 | Bit 5 | Bit 4 | Bit 3 | Bit 2 | Bit 1 | Bit 0 |
| Write: | Bit 7 | Bit 6 | Bit 5 | Bit 4 | Bit 3 | Bit 2 | Bit 1 | Bit 0 |
| Reset: | 0 | 0 | 0 | 0 | 0 | 0 | 0 | 0 |

Figure 16-19. Timer Channel 2 Register Low (TCH2L)

Address: \$0030

| | | | | | | | | |
|--------|--------|--------|--------|--------|--------|--------|-------|-------|
| | Bit 7 | 6 | 5 | 4 | 3 | 2 | 1 | Bit 0 |
| Read: | Bit 15 | Bit 14 | Bit 13 | Bit 12 | Bit 11 | Bit 10 | Bit 9 | Bit 8 |
| Write: | Bit 15 | Bit 14 | Bit 13 | Bit 12 | Bit 11 | Bit 10 | Bit 9 | Bit 8 |
| Reset: | 0 | 0 | 0 | 0 | 0 | 0 | 0 | 0 |

Figure 16-20. Timer Channel 3 Register High (TCH3H)

Address: \$0031

| | | | | | | | | |
|--------|-------|-------|-------|-------|-------|-------|-------|-------|
| | Bit 7 | 6 | 5 | 4 | 3 | 2 | 1 | Bit 0 |
| Read: | Bit 7 | Bit 6 | Bit 5 | Bit 4 | Bit 3 | Bit 2 | Bit 1 | Bit 0 |
| Write: | Bit 7 | Bit 6 | Bit 5 | Bit 4 | Bit 3 | Bit 2 | Bit 1 | Bit 0 |
| Reset: | 0 | 0 | 0 | 0 | 0 | 0 | 0 | 0 |

Figure 16-21. Timer Channel 3 Register Low (TCH3L)

Chapter 17

Input/Output (I/O) Ports

17.1 Introduction

Twenty-four bidirectional input/output (I/O) pins form three parallel ports. All I/O pins are programmable as inputs or outputs.

NOTE

Connect any unused I/O pins to an appropriate logic level, either V_{DD} or V_{SS} . Although the I/O ports do not require termination for proper operation, termination reduces excess current consumption and the possibility of electrostatic damage.

| Addr. | Register Name | Bit 7 | 6 | 5 | 4 | 3 | 2 | 1 | Bit 0 | |
|--------|----------------------------------|--------|---------------------|-------|-------|-------|-------|-------|-------|-------|
| \$0000 | Port A Data Register (PTA) | Read: | PTA7 | PTA6 | PTA5 | PTA4 | PTA3 | PTA2 | PTA1 | PTA0 |
| | | Write: | | | | | | | | |
| | | Reset: | Unaffected by reset | | | | | | | |
| \$0001 | Port B Data Register (PTB) | Read: | PTB7 | PTB6 | PTB5 | PTB4 | PTB3 | PTB2 | PTB1 | PTB0 |
| | | Write: | | | | | | | | |
| | | Reset: | Unaffected by reset | | | | | | | |
| \$0002 | Port C Data Register (PTC) | Read: | PTC7 | PTC6 | PTC5 | PTC4 | PTC3 | PTC2 | PTC1 | PTC0 |
| | | Write: | | | | | | | | |
| | | Reset: | Unaffected by reset | | | | | | | |
| \$0004 | Data Direction Register A (DDRA) | Read: | DDRA7 | DDRA6 | DDRA5 | DDRA4 | DDRA3 | DDRA2 | DDRA1 | DDRA0 |
| | | Write: | | | | | | | | |
| | | Reset: | 0 | 0 | 0 | 0 | 0 | 0 | 0 | 0 |
| \$0005 | Data Direction Register B (DDRB) | Read: | DDRB7 | DDRB6 | DDRB5 | DDRB4 | DDRB3 | DDRB2 | DDRB1 | DDRB0 |
| | | Write: | | | | | | | | |
| | | Reset: | 0 | 0 | 0 | 0 | 0 | 0 | 0 | 0 |
| \$0006 | Data Direction Register C (DDRC) | Read: | DDRC7 | DDRC6 | DDRC5 | DDRC4 | DDRC3 | DDRC2 | DDRC1 | DDRC0 |
| | | Write: | | | | | | | | |
| | | Reset: | 0 | 0 | 0 | 0 | 0 | 0 | 0 | 0 |

Figure 17-1. I/O Port Register Summary

17.2 Port A

Port A is an 8-bit, general-purpose, bidirectional I/O port.

17.2.1 Port A Data Register

The port A data register (PTA) contains a data latch for each of the eight port A pins.

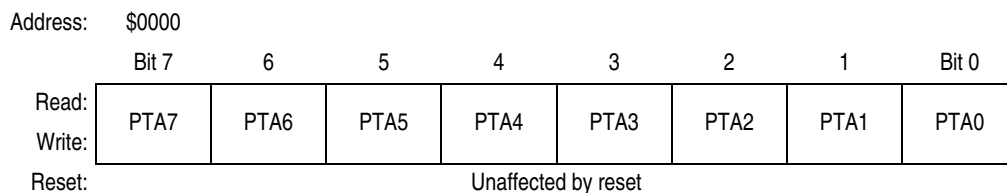

Figure 17-2. Port A Data Register (PTA)

PTA7–PTA0 — Port A data bits

These read/write bits are software programmable. Data direction of each port A pin is under the control of the corresponding bit in data direction register A. Reset has no effect on port A data.

17.2.2 Data Direction Register A

Data direction register A (DDRA) determines whether each port A pin is an input or an output. Writing a logic 1 to a DDRA bit enables the output buffer for the corresponding port A pin; a logic 0 disables the output buffer.

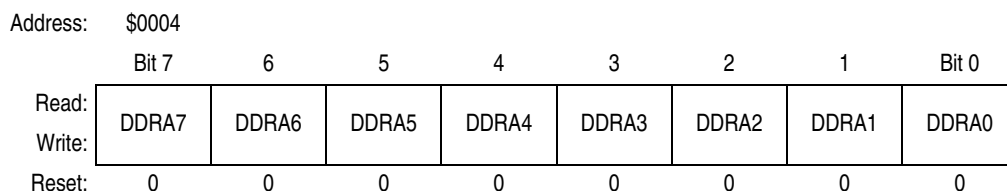

Figure 17-3. Data Direction Register A (DDRA)

DDRA7–DDRA0 — Data direction register A bits

These read/write bits control port A data direction. Reset clears DDRA7–DDRA0, configuring all port A pins as inputs.

1 = Corresponding port A pin configured as output

0 = Corresponding port A pin configured as input

NOTE

Avoid glitches on port A pins by writing to the port A data register before changing data direction register A bits from 0 to 1.

Figure 17-4 shows the port A I/O logic.

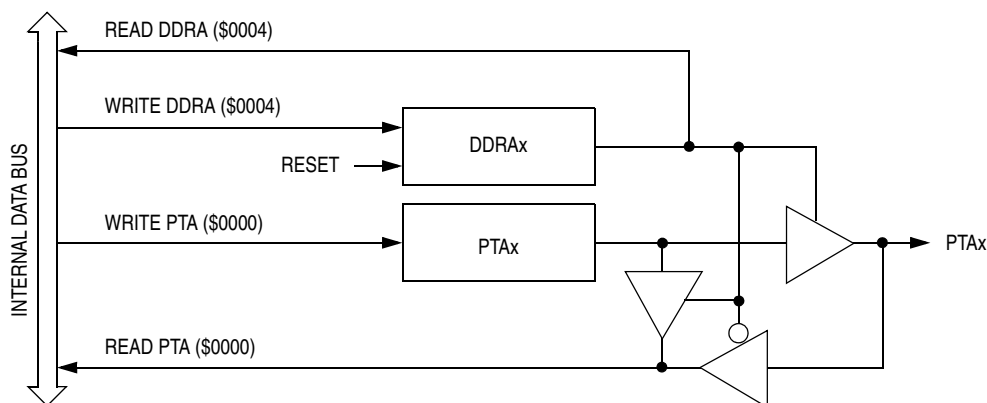

Figure 17-4. Port A I/O Circuit

When bit DDRAx is a logic 1, reading address \$0000 reads the PTAx data latch. When bit DDRAx is a logic 0, reading address \$0000 reads the voltage level on the pin. The data latch can always be written, regardless of the state of its data direction bit. [Table 17-1](#) summarizes the operation of the port A pins.

Table 17-1. Port A Pin Functions

| DDRA bit | PTA bit | I/O pin mode | Accesses to DDRA | Accesses to PTA | |
|----------|------------------|----------------------------|------------------|-----------------|--------------------------|
| | | | Read/Write | Read | Write |
| 0 | X ⁽¹⁾ | Input, Hi-Z ⁽²⁾ | DDRA7–DDRA0 | Pin | PTA7–PTA0 ⁽³⁾ |
| 1 | X | Output | DDRA7–DDRA0 | PTA7–PTA0 | PTA7–PTA0 |

1. X = don't care
2. Hi-Z = high impedance
3. Writing affects data register, but does not affect input.

17.3 Port B

Port B is an 8-bit, general-purpose, bidirectional I/O port.

17.3.1 Port B Data Register

The port B data register (PTB) contains a data latch for each of the eight port B pins.

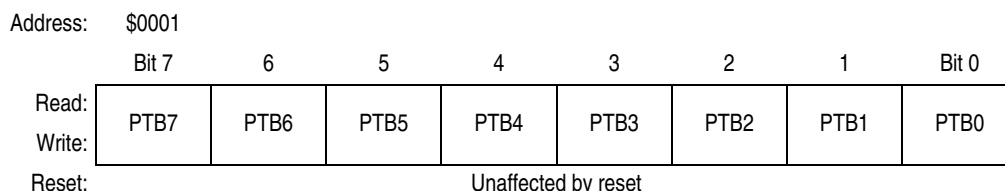

Figure 17-5. Port B Data Register (PTB)

PTB7–PTB0 — Port B data bits

These read/write bits are software-programmable. Data direction of each port B pin is under the control of the corresponding bit in data direction register B. Reset has no effect on port B data.

The port B interrupt enable bits, PTB7IE–PTB0IE, in the port B interrupt control register (PTBICR) enable the port B pins as external interrupt pins. See [Chapter 11 External Interrupt Module \(IRQ\)](#).

17.3.2 Data Direction Register B

Data direction register B (DDRB) determines whether each port B pin is an input or an output. Writing a logic 1 to a DDRB bit enables the output buffer for the corresponding port B pin; a logic 0 disables the output buffer.

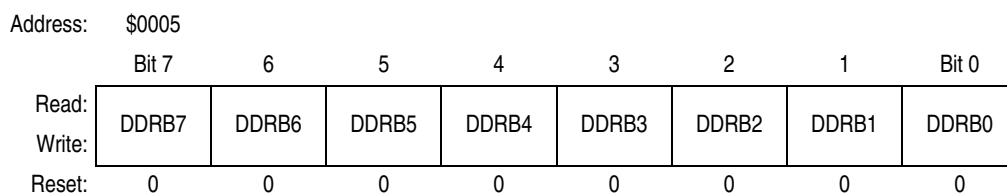

Figure 17-6. Data Direction Register B (DDRB)

DDRB7–DDRB0 — Data direction register B bits

These read/write bits control port B data direction. Reset clears DDRB7–DDRB0, configuring all port B pins as inputs.

- 1 = Corresponding port B pin configured as output
- 0 = Corresponding port B pin configured as input

NOTE

Avoid glitches on port B pins by writing to the port B data register before changing data direction register B bits from 0 to 1.

Figure 17-7 shows the port B I/O logic.

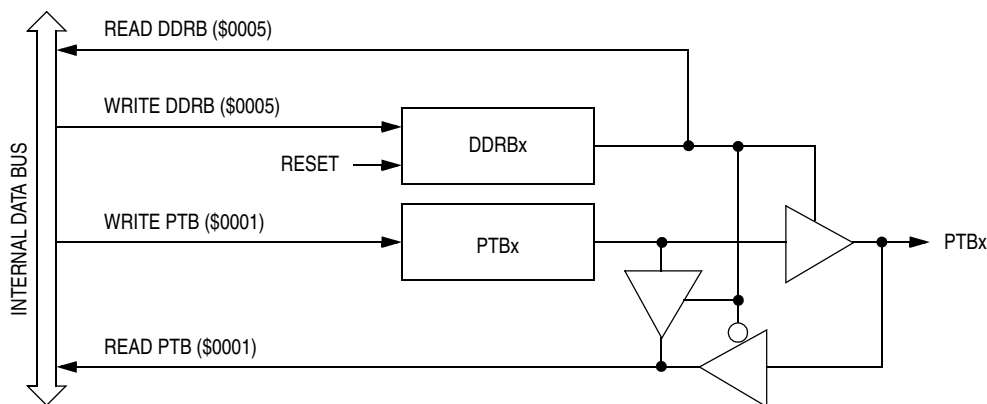

Figure 17-7. Port B I/O Circuit

When bit DDRBx is a logic 1, reading address \$0001 reads the PTBx data latch. When bit DDRBx is a logic 0, reading address \$0001 reads the voltage level on the pin. The data latch can always be written, regardless of the state of its data direction bit. Table 17-2 summarizes the operation of the port B pins.

Table 17-2. Port B Pin Functions

| DDRB bit | PTB bit | I/O pin mode | Accesses to DDRB | | |
|----------|------------------|----------------------------|------------------|-----------|--------------------------|
| | | | Accesses to PTB | | |
| | | | Read/Write | Read | Write |
| 0 | X ⁽¹⁾ | Input, Hi-Z ⁽²⁾ | DDRB7–DDRB0 | Pin | PTB7–PTB0 ⁽³⁾ |
| 1 | X | Output | DDRB7–DDRB0 | PTB7–PTB0 | PTB7–PTB0 |

1. X = don't care
2. Hi-Z = high impedance
3. Writing affects data register, but does not affect input.

17.4 Port C

Port C is an 8-bit, general-purpose, bidirectional I/O port.

17.4.1 Port C Data Register

The port C data register (PTC) contains a data latch for each of the eight port C pins.

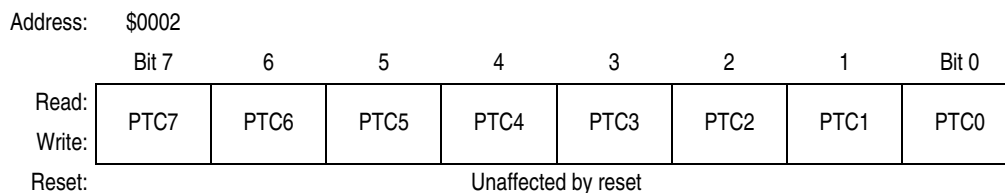

Figure 17-8. Port C Data Register (PTC)

PTC7–PTC0 — Port C data bits

These read/write bits are software-programmable. Data direction of each port C pin is under the control of the corresponding bit in data direction register C. Reset has no effect on port C data.

17.4.2 Data Direction Register C

Data direction register C (DDRC) determines whether each port C pin is an input or an output. Writing a logic 1 to a DDRC bit enables the output buffer for the corresponding port C pin; a logic 0 disables the output buffer.

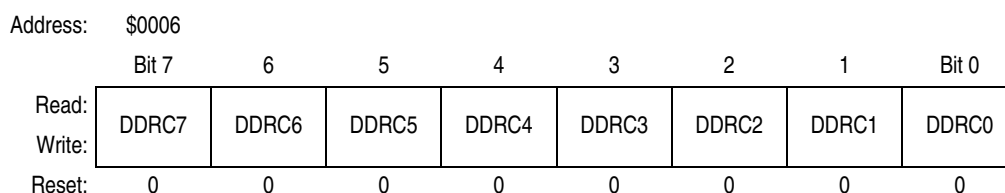

Figure 17-9. Data Direction Register C (DDRC)

DDRC7–DDRC0 — Data direction register C bits

These read/write bits control port C data direction. Reset clears DDRC7–DDRC0, configuring all port C pins as inputs.

1 = Corresponding port C pin configured as output

0 = Corresponding port C pin configured as input

NOTE

Avoid glitches on port C pins by writing to the port C data register before changing data direction register C bits from 0 to 1.

Figure 17-10 shows the port C I/O logic.

Input/Output (I/O) Ports

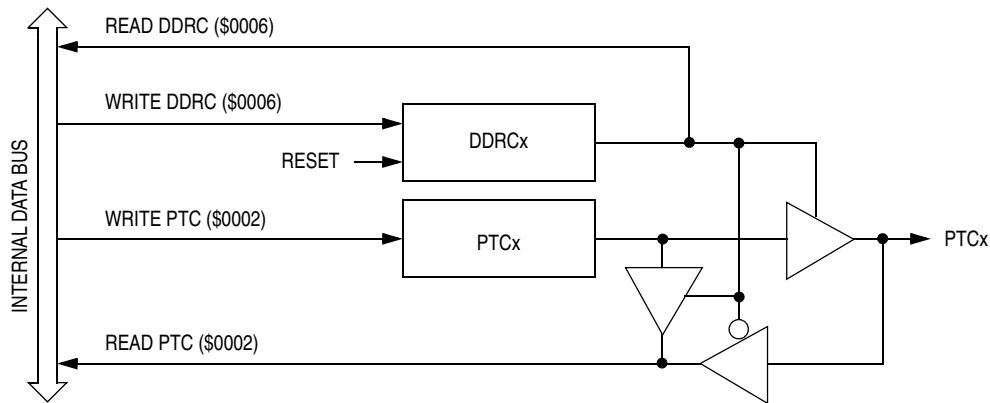

Figure 17-10. Port C I/O Circuit

When bit DDRCx is a logic 1, reading address \$0002 reads the PTCx data latch. When bit DDRCx is a logic 0, reading address \$0002 reads the voltage level on the pin. The data latch can always be written, regardless of the state of its data direction bit. [Table 17-3](#) summarizes the operation of the port C pins.

Table 17-3. Port C Pin Functions

| DDRC bit | PTC bit | I/O pin mode | Accesses to DDRC | | |
|----------|------------------|----------------------------|------------------|-----------|--------------------------|
| | | | Read/Write | | |
| | | | Accesses to PTC | | |
| | | | Read | Write | |
| 0 | X ⁽¹⁾ | Input, Hi-Z ⁽²⁾ | DDRC7–DDRC0 | Pin | PTC7–PTC0 ⁽³⁾ |
| 1 | X | Output | DDRC7–DDRC0 | PTC7–PTC0 | PTC7–PTC0 |

1. X = don't care
2. Hi-Z = high impedance
3. Writing affects data register, but does not affect input.

Chapter 18

Monitor ROM (MON)

18.1 Introduction

This section describes the monitor read-only memory (ROM). The monitor ROM (MON) allows complete testing of the MCU through a single-wire interface with a host computer.

18.2 Features

Features of the MON include:

- Normal user-mode pin functionality
- One pin dedicated to serial communication between monitor ROM and host computer
- Standard mark/space non-return-to-zero (NRZ) communication with host computer
- 4800-baud to 28.8-Kbaud communication with host computer
- Execution of code in random-access memory (RAM) or ROM

18.3 Functional Description

The monitor ROM receives and executes commands from a host computer. [Figure 18-1](#) shows a sample circuit used to enter monitor mode and communicate with a host computer via a standard RS-232 interface.

Simple monitor commands can access any memory address. In monitor mode, the MCU can execute host-computer code in RAM while all MCU pins retain normal operating mode functions. All communication between the host computer and the MCU is through the PTA0 pin. A level-shifting and multiplexing interface is required between PTA0 and the host computer. PTA0 is used in a wired-OR configuration and requires a pullup resistor.

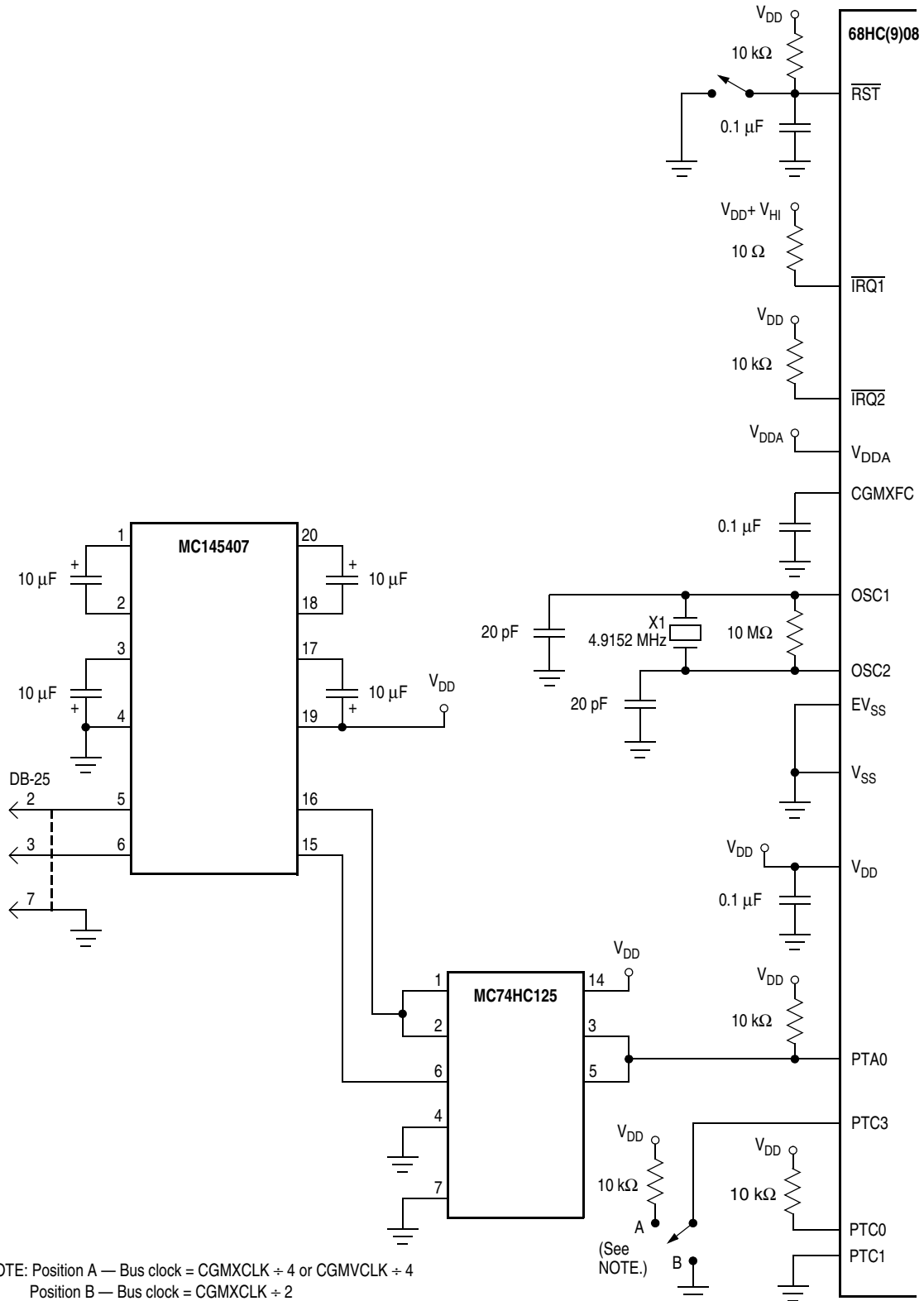

Figure 18-1. Monitor Mode Circuit

18.3.1 Entering Monitor Mode

Table 18-1 shows the pin conditions for entering monitor mode.

Table 18-1. Mode Selection

| $\overline{\text{IRQ1}}$ pin | PTC0 pin | PTC1 pin | PTA0 pin | PTC3 pin | Mode | CGMOUT | Bus frequency |
|------------------------------|----------|----------|----------|----------|---------|--|---------------------------|
| $V_{DD} + V_{HI}$ | 1 | 0 | 1 | 1 | Monitor | $\frac{\text{CGMXCLK}}{2}$ or $\frac{\text{CGMVCLK}}{2}$ | $\frac{\text{CGMOUT}}{2}$ |
| $V_{DD} + V_{HI}$ | 1 | 0 | 1 | 0 | Monitor | CGMXCLK | $\frac{\text{CGMOUT}}{2}$ |

Enter monitor mode by either:

- Executing a software interrupt instruction (SWI) or
- Applying a logic 0 and then a logic 1 to the $\overline{\text{RST}}$ pin

The MCU sends a break signal (10 consecutive logic 0s) to the host computer, indicating that it is ready to receive a command. The break signal also provides a timing reference to allow the host to determine the necessary baud rate.

Monitor mode uses alternate vectors for reset, SWI, and break interrupt. The alternate vectors are in the \$FE page instead of the \$FF page and allow code execution from the internal monitor firmware instead of user code. The COP module is disabled in monitor mode as long as $V_{DD} + V_{HI}$ is applied to either the $\overline{\text{IRQ1}}$ pin or the $\overline{\text{RST}}$ pin. See [Chapter 6 System Integration Module \(SIM\)](#) for more information on modes of operation.

NOTE

Holding the PTC3 pin low when entering monitor mode causes a bypass of a divide-by-two stage at the oscillator. The CGMOUT frequency is equal to the CGMXCLK frequency, and the OSC1 input directly generates internal bus clocks. In this case, the OSC1 signal must have a 50% duty cycle at maximum bus frequency.

Table 18-2 is a summary of the differences between user mode and monitor mode.

Table 18-2. Mode Differences

| Modes | Functions | | | | | | |
|------------------------|-------------------------|-------------------|------------------|-------------------|------------------|-----------------|----------------|
| | COP | Reset vector high | Reset vector low | Break vector high | Break vector low | SWI vector high | SWI vector low |
| User | Enabled | \$FFFE | \$FFFF | \$FFFC | \$FFFD | \$FFFC | \$FFFD |
| Monitor ⁽¹⁾ | Disabled ⁽²⁾ | \$FEFE | \$FEFF | \$FEFC | \$FEFD | \$FEFC | \$FEFD |

1. If PTA0 is low out of reset, the CPU performs a jump to RAM for burn-in.

2. If the high voltage ($V_{DD} + V_{HI}$) is removed from the $\overline{\text{IRQ1}}$ pin or the $\overline{\text{RST}}$ pin, the SIM asserts its COP enable output.

Monitor ROM (MON)

18.3.2 Data Format

Communication with the monitor ROM is in standard non-return-to-zero (NRZ) mark/space data format. (See [Figure 18-2](#) and [Figure 18-3](#).)

The data transmit and receive rate can be anywhere from 4800 baud to 28.8 Kbaud. Transmit and receive baud rates must be identical.

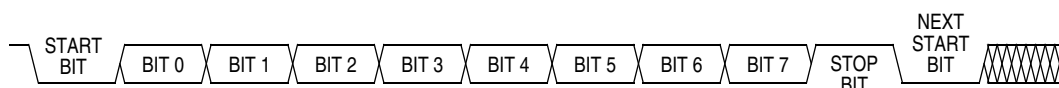

Figure 18-2. Monitor Data Format

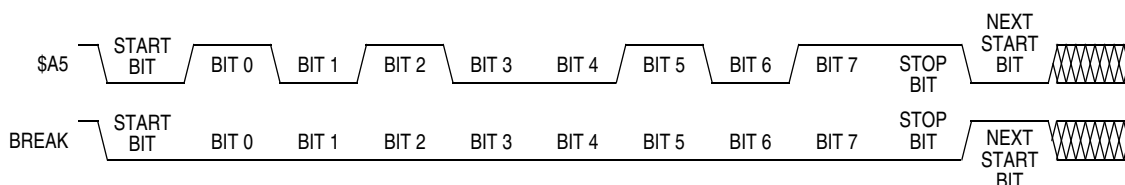

Figure 18-3. Sample Monitor Waveforms

18.3.3 Echoing

As shown in [Figure 18-4](#), the monitor ROM immediately echoes each received byte back to the PTA0 pin for error checking.

Any result of a command appears after the echo of the last byte of the command.

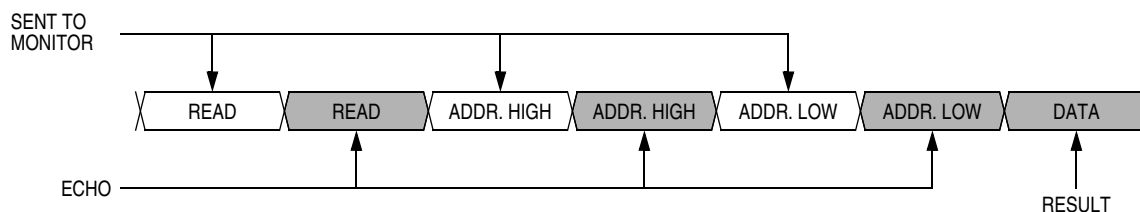

Figure 18-4. Read Transaction

18.3.4 Break Signal

A start bit followed by nine low bits is a break signal. (See [Figure 18-5](#).) When the monitor receives a break signal, it drives the PTA0 pin high for the duration of two bits before echoing the break signal.

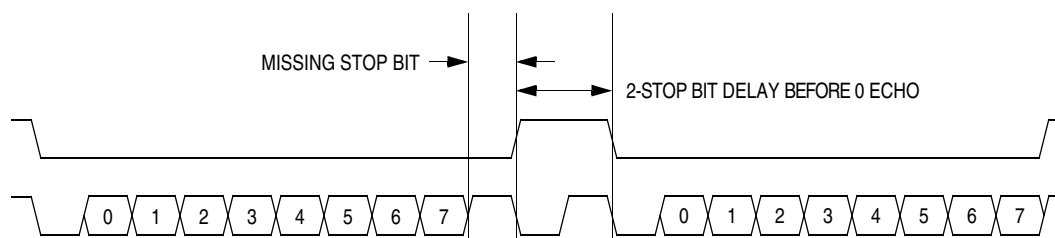

Figure 18-5. Break Transaction

The monitor ROM uses these commands:

- READ (read memory)
- WRITE (write memory)
- IREAD (indexed read)
- IWRITE (indexed write)
- READSP (read stack pointer)
- RUN (run user program)

Table 18-3. READ (Read Memory) Command

| | |
|-------------------------|--|
| Description | Read byte from memory |
| Operand | Specifies 2-byte address in high byte:low byte order |
| Data returned | Returns contents of specified address |
| Opcode | \$4A |
| <p>Command sequence</p> | |

Table 18-4. WRITE (Write Memory) Command

| | |
|-------------------------|--|
| Description | Write byte to memory |
| Operand | Specifies 2-byte address in high byte:low byte order; low byte followed by data byte |
| Data returned | None |
| Opcode | \$49 |
| <p>Command sequence</p> | |

Table 18-5. IREAD (Indexed Read) Command

| | |
|---|--|
| Description | Read next 2 bytes in memory from last address accessed |
| Operand | Specifies 2-byte address in high byte:low byte order |
| Data returned | Returns contents of next two addresses |
| Opcode | \$1A |
| <p>Command sequence</p> <p>The diagram shows a sequence of four blocks: IREAD, IREAD, DATA, and DATA. An arrow labeled 'SENT TO MONITOR' points to the first IREAD block. An arrow labeled 'ECHO' points to the second IREAD block. An arrow labeled 'RESULT' points to the first DATA block. The second DATA block is also labeled 'RESULT'.</p> | |

Table 18-6. IWRITE (Indexed Write) Command

| | |
|---|------------------------------------|
| Description | Write to last address accessed + 1 |
| Operand | Specifies single data byte |
| Data returned | None |
| Opcode | \$19 |
| <p>Command sequence</p> <p>The diagram shows a sequence of four blocks: IWRITE, IWRITE, DATA, and DATA. An arrow labeled 'SENT TO MONITOR' points to the first IWRITE block. Another arrow labeled 'SENT TO MONITOR' points to the second IWRITE block. An arrow labeled 'ECHO' points to the first DATA block. The second DATA block is also labeled 'ECHO'.</p> | |

A sequence of IREAD or IWRITE commands can access a block of memory sequentially over the full 64-Kbyte memory map.

Table 18-7. READSP (Read Stack Pointer) Command

| | |
|--|---|
| Description | Reads stack pointer |
| Operand | None |
| Data returned | Returns stack pointer in high byte:low byte order |
| Opcode | \$0C |
| Command sequence | |
| <pre> sequenceDiagram participant M as SENT TO MONITOR participant E as ECHO participant R as RESULT M->>P1[READSP] P1->>P2[READSP] P2->>P3[SP HIGH] P3->>P4[SP LOW] E->>P2 R->>P3 R->>P4 </pre> | |

Table 18-8. RUN (Run User Program) Command

| | |
|---|--------------------------|
| Description | Executes RTI instruction |
| Operand | None |
| Data returned | None |
| Opcode | \$28 |
| Command sequence | |
| <pre> sequenceDiagram participant M as SENT TO MONITOR participant E as ECHO M->>P1[RUN] P1->>P2[RUN] E->>P2 </pre> | |

18.3.5 Baud Rate

With a 4.9152-MHz crystal and the PTC3 pin at logic 1 during reset, data is transferred between the monitor and host at 4800 baud. If the PTC3 pin is at logic 0 during reset, the monitor baud rate is 9600. When the CGM output, CGMOUT, is driven by the PLL, the baud rate is determined by the MUL11–MULO bits in the PLL multiplier registers. See [Chapter 7 Clock Generator Module \(CGMB\)](#).

Table 18-9. Monitor Baud Rate Selection

| | VCO frequency multiplier (N) | | | | | |
|-------------------|------------------------------|------|--------|--------|--------|--------|
| | 1 | 2 | 3 | 4 | 5 | 6 |
| Monitor baud rate | 4800 | 9600 | 14,400 | 19,200 | 24,000 | 28,800 |

Chapter 19

Keyboard Interrupt (KBI) Module

19.1 Introduction

The keyboard interrupt (KBI) module provides eight independently maskable external interrupt pins.

19.2 Features

Features include:

- Eight keyboard interrupt pins with separate keyboard interrupt enable bits and one keyboard interrupt mask
- The keyboard interrupt module shares the 8-bit bidirectional I/O port with port B.

19.3 Functional Description

Writing to the KBIE7–KBIE0 bits in the keyboard interrupt enable register independently enables or disables each port B pin as a keyboard interrupt pin. Enabling a keyboard interrupt pin also enables its internal pullup device. A logic 0 applied to an enabled keyboard interrupt pin latches a keyboard interrupt request.

A keyboard interrupt request is latched when one or more keyboard pins goes low after all were high.

Vector fetch or software clear

A vector fetch generates an interrupt acknowledge signal to clear the interrupt request. Software can generate the interrupt acknowledge signal by writing a logic 1 to the ACK2, IRQ2 interrupt request acknowledge bit in the IRQ status and control register (ISCR). The ACK2 bit is useful in applications that poll the keyboard interrupt pins and require software to clear the keyboard interrupt request. Writing to the ACK2 bit in an interrupt service routine can also prevent spurious interrupts due to noise. Setting ACK2 does not affect subsequent transitions on the keyboard interrupt pins. A falling edge that occurs after writing to the ACK2 bit latches another interrupt request. If the keyboard interrupt mask bit, IMASK2, is clear, the CPU loads the program counter with the vector address at locations \$FFD2 and \$FFD3. See [19.6.1 IRQ Status and Control Register](#).

Return of all enabled keyboard interrupt pins to logic 1

As long as any enabled keyboard interrupt pin is at logic 0, the keyboard interrupt request remains set.

The vector fetch or software clear and the return of all enabled keyboard interrupt pins to logic 1 may occur in any order.

Reset clears the keyboard interrupt request.

The PIN2 bit in the ISCR can be used to see if a pending interrupt exists. The PIN2 bit is not affected by the keyboard interrupt mask bit IMASK2. See [19.6.1 IRQ Status and Control Register](#).

Keyboard Interrupt (KBI) Module

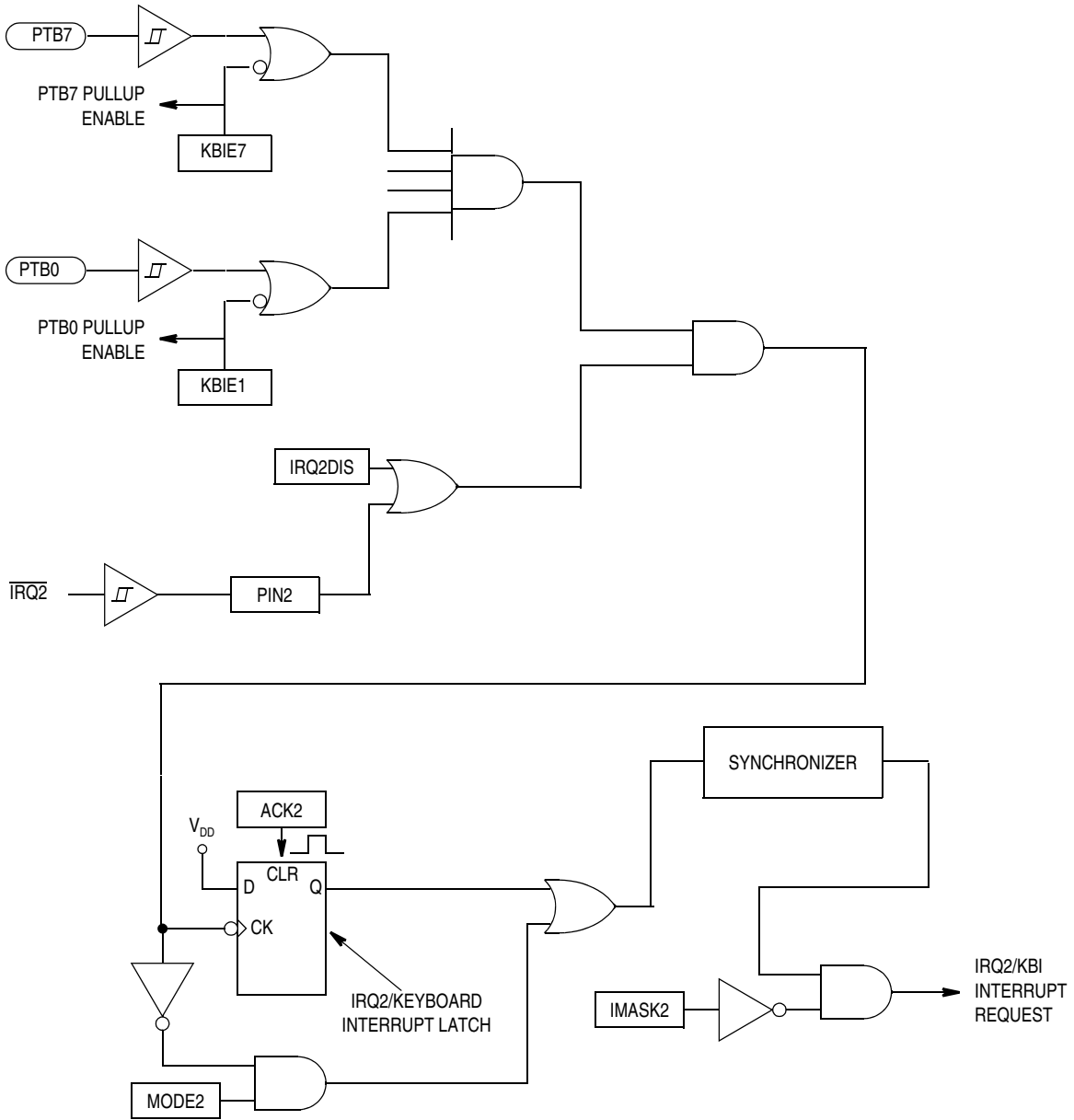

Figure 19-1. Block Diagram

To determine the logic level on a keyboard interrupt pin, use the data direction register to configure the pin as an input and read the data register.

NOTE

Setting a keyboard interrupt enable bit (KBIE_x) forces the corresponding keyboard interrupt pin to be an input, overriding the data direction register. However, the data direction register bit must be a logic 0 for software to read the pin.

19.4 Initialization

When a keyboard interrupt pin is enabled, it takes time for the internal pullup to reach a logic 1. Therefore, a false interrupt can occur as soon as the pin is enabled.

To prevent a false interrupt on keyboard initialization:

1. Mask keyboard interrupts by setting the IMASK2 bit in the ISCR. See [19.6.1 IRQ Status and Control Register](#).
2. Enable the KBI pins by setting the appropriate KBIE_x bits in the keyboard interrupt enable register.
3. Write to the ACK2 bit in the ISCR to clear any false interrupts. See [19.6.1 IRQ Status and Control Register](#).
4. Clear the IMASK2 bit.

An interrupt signal on an edge-triggered pin can be acknowledged immediately after enabling the pin.

Another way to avoid a false interrupt:

1. Configure the keyboard pins as outputs by setting the appropriate DDRB bits in data direction register B.
2. Write logic 1s to the appropriate port B data register bits.
3. Enable the KBI pins by setting the appropriate KBIE_x bits in the keyboard interrupt enable register.

19.5 Wait Mode

The keyboard interrupt module remains active in wait mode. Clearing the IASK2 bit in the ISCR enables keyboard interrupt requests to bring the MCU out of wait mode.

19.6 I/O Registers

These registers control and monitor operation of the keyboard interrupt module:

- IRQ status and control register (ISCR)
- Keyboard interrupt enable register (KBIE_R)

19.6.1 IRQ Status and Control Register

See [11.5 IRQ Status and Control Register](#).

Keyboard Interrupt (KBI) Module

19.6.2 Keyboard Interrupt Enable Register

The keyboard interrupt enable register enables or disables each port B pin to operate as a keyboard interrupt pin.

Address: \$0003

| | Bit 7 | 6 | 5 | 4 | 3 | 2 | 1 | Bit 0 |
|--------|-------|-------|-------|-------|-------|-------|-------|-------|
| Read: | KBIE7 | KBIE6 | KBIE5 | KBIE4 | KBIE3 | KBIE2 | KBIE1 | KBIE0 |
| Write: | | | | | | | | |
| Reset: | 0 | 0 | 0 | 0 | 0 | 0 | 0 | 0 |

Figure 19-2. Keyboard Interrupt Enable Register (KBIER)

KBIE7–KBIE0 — Keyboard interrupt enable bits

Each of these read/write bits enables the corresponding keyboard interrupt pin to latch interrupt requests. Reset clears the keyboard interrupt enable register.

1 = PBx pin enabled as keyboard interrupt pin

0 = PBx pin not enabled as keyboard interrupt pin

Chapter 20

Preliminary Electrical Specifications

20.1 Introduction

This section contains preliminary electrical and timing specifications. These values are design targets and have not yet been tested.

20.2 Absolute Maximum Ratings

Maximum ratings are the extreme limits to which the MCU can be exposed without permanently damaging it.

The MCU contains circuitry to protect the inputs against damage from high static voltages; however, do not apply voltages higher than those shown in this table. Keep V_{IN} and V_{Out} within the range $V_{SS} \leq (V_{In} \text{ or } V_{Out}) \leq V_{DD}$. Connect unused inputs to the appropriate voltage level, either V_{SS} or V_{DD} .

| Rating | Symbol | Value | Unit |
|---|------------|----------------------------------|------|
| Supply voltage | V_{DD} | -0.3 to +3.6 | V |
| Input voltage | V_{IN} | $V_{SS} - 0.3$ to $V_{DD} + 0.3$ | V |
| Maximum current per pin excluding V_{DD} and V_{SS} | I | ± 25 | mA |
| Storage temperature | T_{STG} | -55 to +150 | °C |
| Maximum current out of V_{SS} | I_{MVSS} | 100 | mA |
| Maximum current into V_{DD} | I_{MVDD} | 100 | mA |

NOTE: Voltages are referenced to V_{SS} .

NOTE

This device is not guaranteed to operate properly at the maximum ratings. Refer to [20.5 3.0 Volt ± 10% DC Electrical Characteristics](#) and [20.6 2.0 Volt ± 10% DC Electrical Characteristics](#) for guaranteed operating conditions.

Electrostatic discharge (ESD) protection is provided on each pin to 2000 volts using the human body model of 100 pF and 1500 ohms. Using the machine model, ESD protection is provided to 200 volts at 100 pF and 0 ohms.

20.3 Functional Operating Range

| Rating | Symbol | Value ⁽¹⁾ | Unit |
|--|----------|------------------------|------|
| Operating temperature range | T_A | -20 to +65 | °C |
| Operating voltage range ⁽²⁾ | V_{DD} | 2.0 ± 10% 3.0 ± 10% | V |
| LCD operating voltage range ⁽³⁾ | V_{LL} | 2.0 ± 10% 3.0 ± 10% | V |

1. Tested and guaranteed at room temperature only
2. LCD charge pump optimized for given ranges
3. V_{LL} does not have to equal V_{DD} .

20.4 Thermal Characteristics

| Characteristic | Symbol | Value | Unit |
|--|---------------|---|------|
| Thermal resistance, 160 BGA MC68HC08LK60 MC68HC908LK60 | θ_{JA} | 61 50 | °C/W |
| I/O pin power dissipation | $P_{I/O}$ | User Determined | W |
| Power dissipation ⁽¹⁾ | P_D | $P_D = (I_{DD} \times V_{DD}) + P_{I/O}$ $= K / (T_J + 273^\circ\text{C})$ | W |
| Constant ⁽²⁾ | K | $P_D \times (T_A + 273^\circ\text{C})$ $+ (P_D^2 \times \theta_{JA})$ | W/°C |
| Average junction temperature | T_J | $T_A = P_D \times \theta_{JA}$ | °C |
| Maximum junction temperature | T_{JM} | 100 | °C |

1. Power dissipation is a function of temperature.
2. K is a constant unique to the device. K can be determined from a known T_A and measured P_D . With this value of K, P_D and T_J can be determined for any value of T_A .

20.5 3.0 Volt ± 10% DC Electrical Characteristics

| Characteristic ⁽¹⁾ | Symbol | Min | Typ ⁽²⁾ | Max | Unit |
|---|-----------------------|---------------------|--------------------|---------------------|------|
| Output high voltage ($I_{Load} = -0.4$ mA) all pins | V_{OH} | $0.7 \times V_{DD}$ | — | — | V |
| Output low voltage ($I_{Load} = 0.8$ mA) all pins | V_{OL} | — | — | $0.3 \times V_{DD}$ | V |
| Input high voltage All ports, IRQs, RESET, OSC1 | V_{IH} | $0.7 \times V_{DD}$ | — | V_{DD} | V |
| Input low voltage All ports, IRQs, RESET, OSC1 | V_{IL} | V_{SS} | — | $0.3 \times V_{DD}$ | V |
| Monitor mode entry voltage | V_{HI} | — | — | V_{DD} | V |
| V_{DD} supply current | | | | | |
| Run ⁽³⁾ | I_{DD} | — | — | 4 | mA |
| Wait ⁽⁴⁾ | | — | — | 2 | |
| I/O ports high-impedance leakage current | I_{IL} | — | — | ± 10 | μA |
| Input current | I_{In} | — | — | ±1 | μA |
| Capacitance Ports (as input or output) | C_{Out} C_{In} | — — | — — | 12 8 | pF |
| POR rearm voltage ⁽⁵⁾ | V_{POR} | 0 | — | 200 | mV |
| POR reset voltage ⁽⁶⁾ | V_{PORRST} | 0 | 700 | 800 | mV |
| POR rise time ramp rate ⁽⁷⁾ | R_{POR} | 0.02 | — | — | V/ms |

1. $V_{DD} = 3.0$ Vdc ± 10%, $V_{SS} = 0$ Vdc, $T_A = -20^\circ\text{C}$ to $+65^\circ\text{C}$, unless otherwise noted.

2. Typical values reflect average measurements at midpoint of voltage range, 25°C only.

3. Run (operating) I_{DD} measured using external square wave clock source ($f_{OP} = 4.1$ MHz). All inputs 0.2 V from rail. No dc loads. Less than 100 pF on all outputs. $C_L = 20$ pF on OSC2. All ports configured as inputs. OSC2 capacitance linearly affects run I_{DD} . Measured with all modules enabled.

4. Wait I_{DD} measured using external square wave clock source ($f_{OP} = 4.1$ MHz). All inputs 0.2 V from rail. No dc loads. Less than 100 pF on all outputs. $C_L = 20$ pF on OSC2. All ports configured as inputs. OSC2 capacitance linearly affects wait I_{DD} . Measured with PLL, LCD, and TBM disabled.

5. Maximum is highest voltage that POR is guaranteed.

6. Maximum is highest voltage that POR is possible.

7. If minimum V_{DD} is not reached before the internal POR reset is released, RSTB must be driven low externally until minimum V_{DD} is reached.

20.6 2.0 Volt \pm 10% DC Electrical Characteristics

| Characteristic ⁽¹⁾ | Symbol | Min | Typ ⁽²⁾ | Max | Unit |
|---|-----------------------|---------------------|--------------------|---------------------|---------|
| Output high voltage ($I_{Load} = -0.4$ mA) all pins | V_{OH} | $0.7 \times V_{DD}$ | — | — | V |
| Output low voltage ($I_{Load} = 0.8$ mA) all pins | V_{OL} | — | — | $0.3 \times V_{DD}$ | V |
| Input high voltage All ports, IRQs, RESET, OSC1 | V_{IH} | $0.7 \times V_{DD}$ | — | V_{DD} | V |
| Input low voltage All ports, IRQs, RESET, OSC1 | V_{IL} | V_{SS} | — | $0.3 \times V_{DD}$ | V |
| Monitor mode entry voltage | V_{HI} | — | — | V_{DD} | V |
| V_{DD} supply current | | | | | |
| Run ⁽³⁾ | I_{DD} | — | — | 2 | mA |
| Wait ⁽⁴⁾ | | — | — | 1 | |
| I/O ports high-impedance leakage current | I_{IL} | — | — | ± 10 | μ A |
| Input current | I_{In} | — | — | ± 1 | μ A |
| Capacitance | | | | | |
| Ports (as input or output) | C_{Out} C_{In} | — — | — — | 12 8 | pF |
| POR rearm voltage ⁽⁵⁾ | V_{POR} | 0 | — | 200 | mV |
| POR reset voltage ⁽⁶⁾ | V_{PORRST} | 0 | 700 | 800 | mV |
| POR rise time ramp rate ⁽⁷⁾ | R_{POR} | 0.02 | — | — | V/ms |

- $V_{DD} = 2.0$ Vdc \pm 10%, $V_{SS} = 0$ Vdc, $T_A = -20^\circ\text{C}$ to $+65^\circ\text{C}$, unless otherwise noted.
- Typical values reflect average measurements at midpoint of voltage range, 25°C only.
- Run (operating) I_{DD} measured using external square wave clock source ($f_{OP} = 2$ MHz). All inputs 0.2 V from rail. No dc loads. Less than 100 pF on all outputs. $C_L = 20$ pF on OSC2. All ports configured as inputs. OSC2 capacitance linearly affects run I_{DD} . Measured with all modules enabled.
- Wait I_{DD} measured using external square wave clock source ($f_{OP} = 2$ MHz). All inputs 0.2 V from rail. No dc loads. Less than 100 pF on all outputs. $C_L = 20$ pF on OSC2. All ports configured as inputs. OSC2 capacitance linearly affects wait I_{DD} . Measured with PLL, LCD, and TBM disabled.
- Maximum is highest voltage that POR is guaranteed.
- Maximum is highest voltage that POR is possible.
- If minimum V_{DD} is not reached before the internal POR reset is released, RSTB must be driven low externally until minimum V_{DD} is reached.

20.7 3.0 Volt ± 10% Control Timing

| Characteristic ⁽¹⁾ | Symbol | Min | Max | Unit |
|--|-------------------|-----|-----|------|
| Frequency of operation, ⁽²⁾ crystal option | f _{OSC} | 32 | 100 | kHz |
| Internal operating frequency | f _{OP} | — | 4.0 | MHz |
| Internal bus cycle time | t _{cyc} | — | 250 | ns |
| $\overline{\text{RESET}}$ input pulse width low ⁽³⁾ | t _{IRL} | 125 | — | ns |
| $\overline{\text{IRQ}}$ interrupt pulse width low, ⁽⁴⁾ edge-triggered | t _{ILIH} | 125 | — | ns |

1. V_{DD} = 3.0 Vdc ± 10%, V_{SS} = 0 Vdc; timing shown with respect to 20% V_{DD} and 70% V_{SS} unless otherwise noted

2. See [20.11 PLL2P12M Electrical Specifications](#) for more information.

3. Minimum pulse width reset is guaranteed to be recognized; it is possible for a smaller pulse width to cause a reset.

4. Minimum pulse width is for guaranteed interrupt; it is possible for a smaller pulse width to be recognized.

20.8 2.0 Volt ± 10% Control Timing

| Characteristic ⁽¹⁾ | Symbol | Min | Max | Unit |
|--|-------------------|-----|-----|------|
| Frequency of operation, ⁽²⁾ crystal option | f _{OSC} | 32 | 100 | kHz |
| Internal operating frequency | f _{OP} | — | 2.0 | MHz |
| Internal bus cycle time | t _{cyc} | — | 500 | ns |
| $\overline{\text{RESET}}$ input pulse width low ⁽³⁾ | t _{IRL} | 125 | — | ns |
| $\overline{\text{IRQ}}$ interrupt pulse width low, ⁽⁴⁾ edge-triggered | t _{ILIH} | 125 | — | ns |

1. V_{DD} = 2.0 Vdc ± 10%, V_{SS} = 0 Vdc; timing shown with respect to 20% V_{DD} and 70% V_{SS} unless otherwise noted

2. See [20.11 PLL2P12M Electrical Specifications](#) for more information.

3. Minimum pulse width reset is guaranteed to be recognized; it is possible for a smaller pulse width to cause a reset.

4. Minimum pulse width is for guaranteed interrupt; it is possible for a smaller pulse width to be recognized.

20.9 3.0 Volt ± 10% Serial Peripheral Interface (SPI) Timing

| Num ⁽¹⁾ | Characteristic ⁽²⁾ | Symbol | Min | Max | Unit |
|--------------------|--|----------------------------------|--------------------|------------------------|-----------|
| | Operating frequency Master Slave | $f_{OP(M)}$ $f_{OP(S)}$ | $f_{OP}/128$ dc | $f_{OP}/2$ f_{OP} | MHz |
| 1 | Cycle time Master Slave | $t_{cyc(M)}$ $t_{cyc(S)}$ | 2 1 | 128 — | t_{cyc} |
| 2 | Enable lead time | t_{Lead} | 30 | — | ns |
| 3 | Enable lag time | t_{LAG} | 30 | — | ns |
| 4 | Clock (SCK) high time Master Slave | $t_{W(SCKH)M}$ $t_{W(SCKH)S}$ | 200 100 | — — | ns |
| 5 | Clock (SCK) low time Master Slave | $t_{W(SCKL)M}$ $t_{W(SCKL)S}$ | 200 100 | — — | ns |
| 6 | Data setup time, inputs Master Slave | $t_{SU(M)}$ $t_{SU(S)}$ | 90 10 | — — | ns |
| 7 | Data hold time, inputs Master Slave | $t_{H(M)}$ $t_{H(S)}$ | 0 30 | — — | ns |
| 8 | Access time, slave ⁽³⁾ CPHA = 0 CPHA = 1 | $t_{A(CP0)}$ $t_{A(CP1)}$ | 0 0 | 80 40 | ns |
| 9 | Slave disable time, hold time to high-impedance state ⁽⁴⁾ | t_{DIS} | — | 50 | ns |
| 10 | Data valid time after enable edge ⁽⁵⁾ Master Slave | $t_{V(M)}$ $t_{V(S)}$ | — — | 20 80 | ns |
| 11 | Data hold time, outputs, after enable edge Master Slave | $t_{HO(M)}$ $t_{HO(S)}$ | 0 10 | — — | ns |

1. Item numbers refer to dimensions in [Figure 20-1](#) and [Figure 20-2](#).

2. All timing is shown with respect to 20% V_{DD} and 70% V_{DD} , unless otherwise noted; assumes 100 pF load on all SPI pins.

3. Time to data active from high-impedance state

4. Hold time to high-impedance state

5. With 100 pF on all SPI pins

20.10 2.0 Volt \pm 10% Serial Peripheral Interface (SPI) Timing

| Num ⁽¹⁾ | Characteristic ⁽²⁾ | Symbol | Min | Max | Unit |
|--------------------|--|----------------------------------|--------------------|------------------------|-----------|
| | Operating frequency Master Slave | $f_{OP(M)}$ $f_{OP(S)}$ | $f_{OP}/128$ dc | $f_{OP}/2$ f_{OP} | MHz |
| 1 | Cycle time Master Slave | $t_{cyc(M)}$ $t_{cyc(S)}$ | 2 1 | 128 — | t_{cyc} |
| 2 | Enable lead time | t_{Lead} | 60 | — | ns |
| 3 | Enable lag time | t_{LAG} | 60 | — | ns |
| 4 | Clock (SCK) high time Master Slave | $t_{W(SCKH)M}$ $t_{W(SCKH)S}$ | 400 200 | — — | ns |
| 5 | Clock (SCK) low time Master Slave | $t_{W(SCKL)M}$ $t_{W(SCKL)S}$ | 400 200 | — — | ns |
| 6 | Data setup time, inputs Master Slave | $t_{SU(M)}$ $t_{SU(S)}$ | 180 20 | — — | ns |
| 7 | Data hold time, inputs Master Slave | $t_{H(M)}$ $t_{H(S)}$ | 0 60 | — — | ns |
| 8 | Access time, slave ⁽³⁾ CPHA = 0 CPHA = 1 | $t_{A(CP0)}$ $t_{A(CP1)}$ | 0 0 | 160 80 | ns |
| 9 | Slave disable time, hold time to high-impedance state ⁽⁴⁾ | t_{DIS} | — | 100 | ns |
| 10 | Data valid time after enable edge ⁽⁵⁾ Master Slave | $t_{V(M)}$ $t_{V(S)}$ | — — | 40 160 | ns |
| 11 | Data hold time, outputs, after enable edge Master Slave | $t_{HO(M)}$ $t_{HO(S)}$ | 0 2 | — — | ns |

1. Item numbers refer to dimensions in [Figure 20-1](#) and [Figure 20-2](#).

2. All timing is shown with respect to 20% V_{DD} and 70% V_{DD} , unless otherwise noted; assumes 100 pF load on all SPI pins.

3. Time to data active from high-impedance state

4. Hold time to high-impedance state

5. With 100 pF on all SPI pins

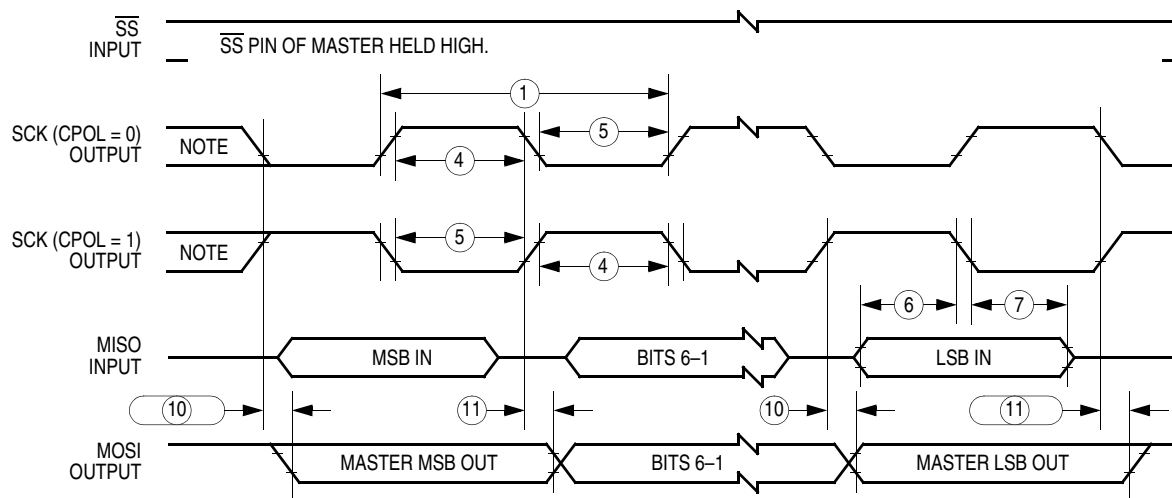

NOTE: This first clock edge is generated internally, but is not seen at the SCK pin.

a) SPI Master Timing (CPHA = 0)

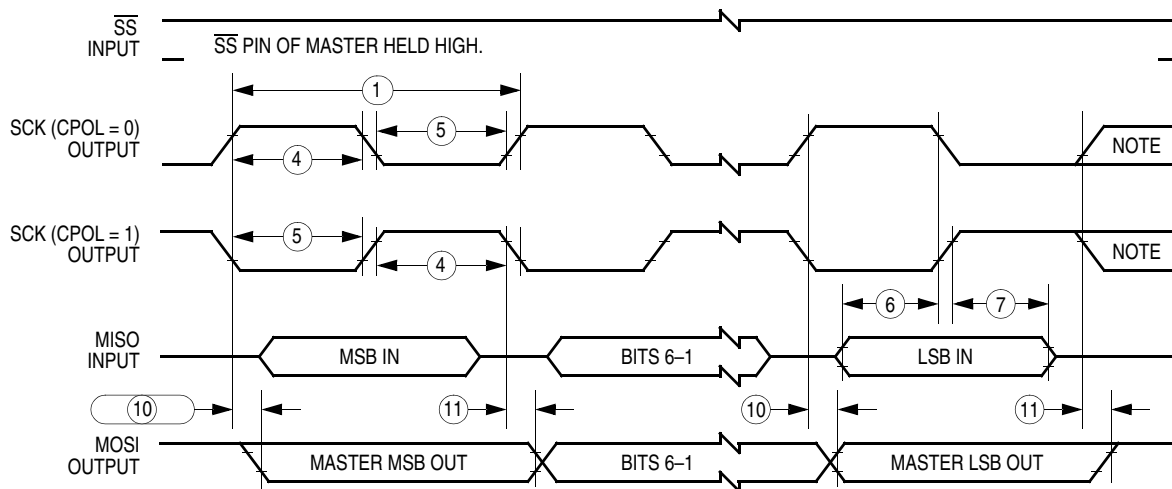

NOTE: This last clock edge is generated internally, but is not seen at the SCK pin.

b) SPI Master Timing (CPHA = 1)

Figure 20-1. SPI Master Timing

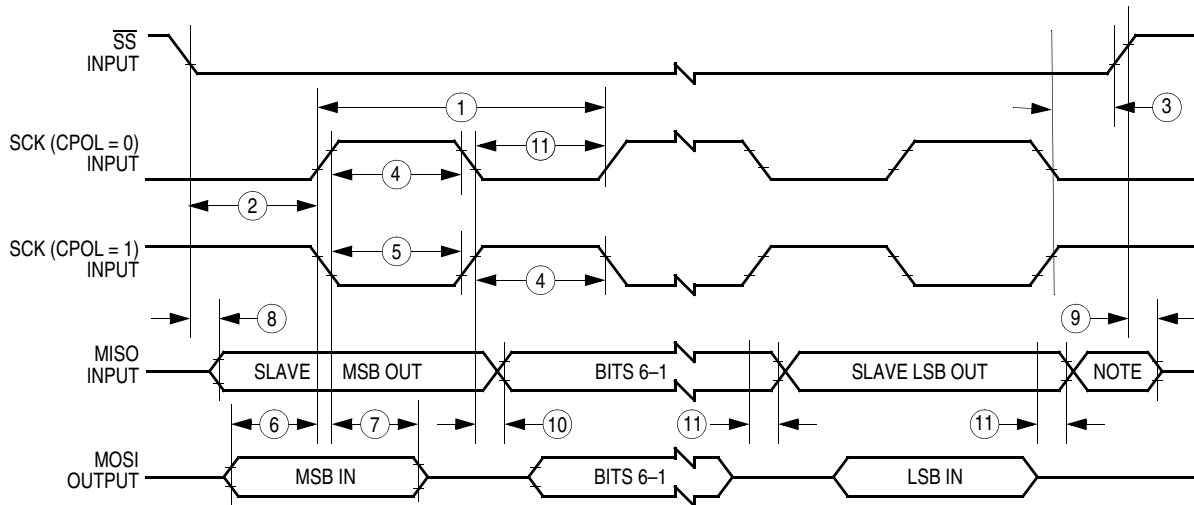

NOTE: Not defined but normally MSB of character just received.

a) SPI Slave Timing (CPHA = 0)

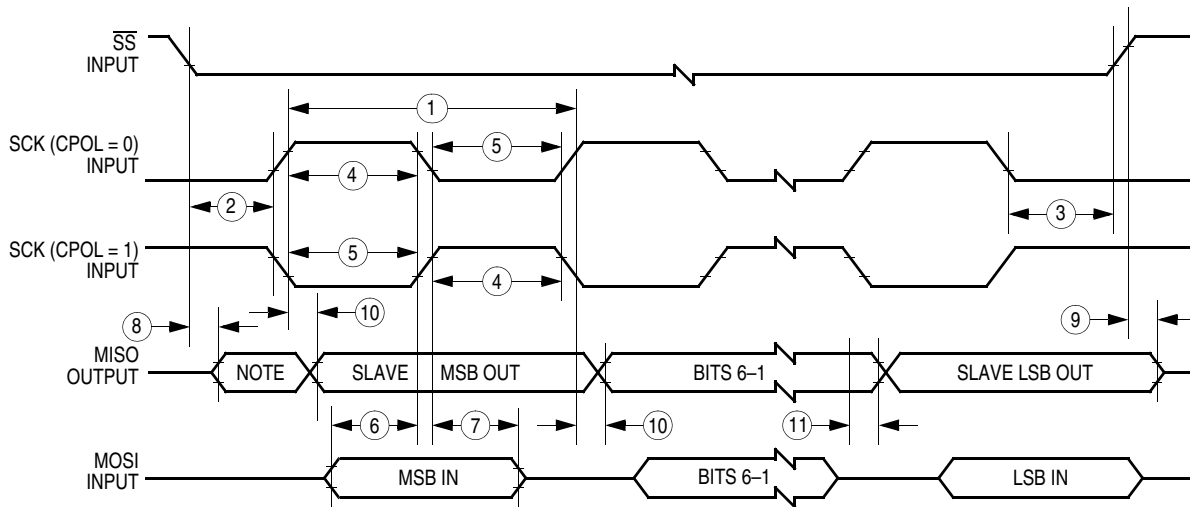

NOTE: Not defined but normally LSB of character previously transmitted.

b) SPI Slave Timing (CPHA = 1)

Figure 20-2. SPI Slave Timing

20.11 PLL2P12M Electrical Specifications

| Description | Symbol | Min | Typ | Max | Notes |
|------------------------------------|------------|------------------|-------------|------------------|--|
| CGMXCLK reference frequency | f_{RCLK} | — | 38.4 kHz | — | |
| Range nominal multiplier (Hz) | f_{NOM} | — | 38.4 k | — | |
| VCO center-of-range frequency (Hz) | f_{VRS} | 38.4 k 38.4 k | — | 20.0 M 10.0 M | 2.7–3.3 V V_{DD} only 1.8–2.7 V V_{DD} |
| VCO range linear range multiplier | L | 1 E = 0 | 64 E = 0 | 255 E = 3 | |
| VCO power-of-two range multiplier | 2^E | 1 | 1 | 8 | |
| VCO multiply factor | N | 1 | 64 | 4095 | |
| VCO prescale multiplier | 2^P | 1 P = 0 | 1 P = 0 | 8 P = 3 | |
| Reference divider factor | R | 1 | 1 | 15 | |
| VCO operating frequency | f_{VCLK} | f_{VRSMIN} | — | f_{VRSMAX} | |
| Bus operating frequency (Hz) | f_{BUS} | — — | — — | 4 M 2 M | 2.7–3.3 V V_{DD} only 1.8–2.7 V V_{DD} only |

20.12 Bus Clock PLL Acquisition/Lock Time Specifications

This section provides specifications for the entry and exit of acquisition and tracking modes, as well as required manual mode delay times.

| Description | Symbol | Min | Typ | Max | Notes |
|---|-----------------|-------------------|--------------------|-------------|---------------------------|
| Filter capacitor multiply factor | C_{Fact} | — | 0.0145 | — | F/sV |
| Acquisition mode time factor | K_{ACQ} | — | 0.117 | — | V |
| Tracking mode time factor | K_{TRK} | — | 0.021 | — | V |
| Manual mode time to stable | t_{ACQ} | — | 10 ms | — | If C_F chosen correctly |
| Manual stable to lock time | t_{AL} | — | 20 ms | — | If C_F chosen correctly |
| Manual acquisition time | t_{Lock} | — | $t_{ACQ} + t_{AL}$ | — | |
| Tracking mode entry frequency tolerance | Δ_{TRK} | 0 | — | $\pm 3.6\%$ | |
| Acquisition mode entry frequency tolerance | Δ_{ACQ} | $\pm 6.3\%$ | — | $\pm 7.2\%$ | |
| LOCK entry frequency tolerance | Δ_{Lock} | 0 | — | $\pm 0.9\%$ | |
| LOCK exit frequency tolerance | Δ_{UNL} | $\pm 0.9\%$ | — | $\pm 1.8\%$ | |
| Reference cycles per acquisition mode measurement | n_{ACQ} | — | 32 | — | |
| Reference cycles per tracking mode measurement | n_{TRK} | — | 128 | — | |
| Automatic mode time to stable | t_{ACQ} | n_{ACQ}/f_{RDV} | 10 ms | — | If C_F chosen correctly |
| Automatic stable to lock time | t_{AL} | n_{TRK}/f_{RDV} | 15 ms | — | If C_F chosen correctly |
| Automatic lock time | t_{Lock} | — | $t_{ACQ} + t_{AL}$ | — | |

20.13 PLL2P12M Component Specifications

| Characteristic | Symbol | Min | Typ | Max | Notes |
|----------------------------|-----------|-----|--------------------------------------|--------------|---|
| Crystal load capacitance | C_L | — | — | — | Consult crystal manufacturer's data |
| Crystal fixed capacitance | C_1 | — | $2 \times C_L$ | — | Consult crystal manufacturer's data |
| Crystal tuning capacitance | C_2 | — | $2 \times C_L$ | — | Consult crystal manufacturer's data |
| Feedback bias resistor | R_B | — | 22 M Ω | — | |
| Series resistor | R_S | 0 | 330 k Ω | 1 M Ω | Not required |
| Filter capacitor | C_F | — | C_{FACT} (V_{DDA}/f_{XCLK}) | — | |
| Bypass capacitor | C_{BYP} | — | 0.1 μ F | — | C_{BYP} must provide low AC impedance from $f = f_{XCLK}/100$ to $100 \times f_{VCLK}$, so series resistance must be considered. |

20.14 RAM Characteristics

| Characteristic | Symbol | Min | Typ | Max | Unit |
|----------------------------|-----------|-----|-----|-----|------|
| RAM data retention voltage | V_{RDR} | 0.7 | — | — | V |

20.15 FLASH Memory Electrical Characteristics

| Parameter | Description | Min | Typ | Max | Units |
|----------------------|-------------------------------|-----|-----|-----|---------------------------------|
| t_{Erase} | Erase time | 40 | 80 | 110 | ms |
| t_{kill} | High voltage kill time | 200 | 200 | — | μ s |
| t_{HVD} | Return to read mode time | 50 | 50 | — | μ s |
| t_{Step} | Program step size | 0.8 | 1.0 | 1.2 | μ s |
| Pulses | Number of program pulses/page | 1 | 8 | 10 | Pulses |
| t_{HVTV} | HVEN low to VVERF high time | 50 | — | — | μ s |
| t_{VTP} | VVERF high to PGM low time | 150 | — | — | μ s |
| Endurance | Erase/program cycles | — | — | 100 | $\chi\psi\lambda\epsilon\sigma$ |
| Pump Clock Frequency | Charge pump frequency | 1.8 | — | 2.5 | MHz |



Chapter 21

Mechanical Data

21.1 Introduction

The following figures show the latest package drawings at the time of this publication. To make sure that you have the latest package specifications, contact your local Freescale Sales Office.

21.2 160 Input/Output, BGA, Standard Map, 15 x 15 Package (Case #1268)

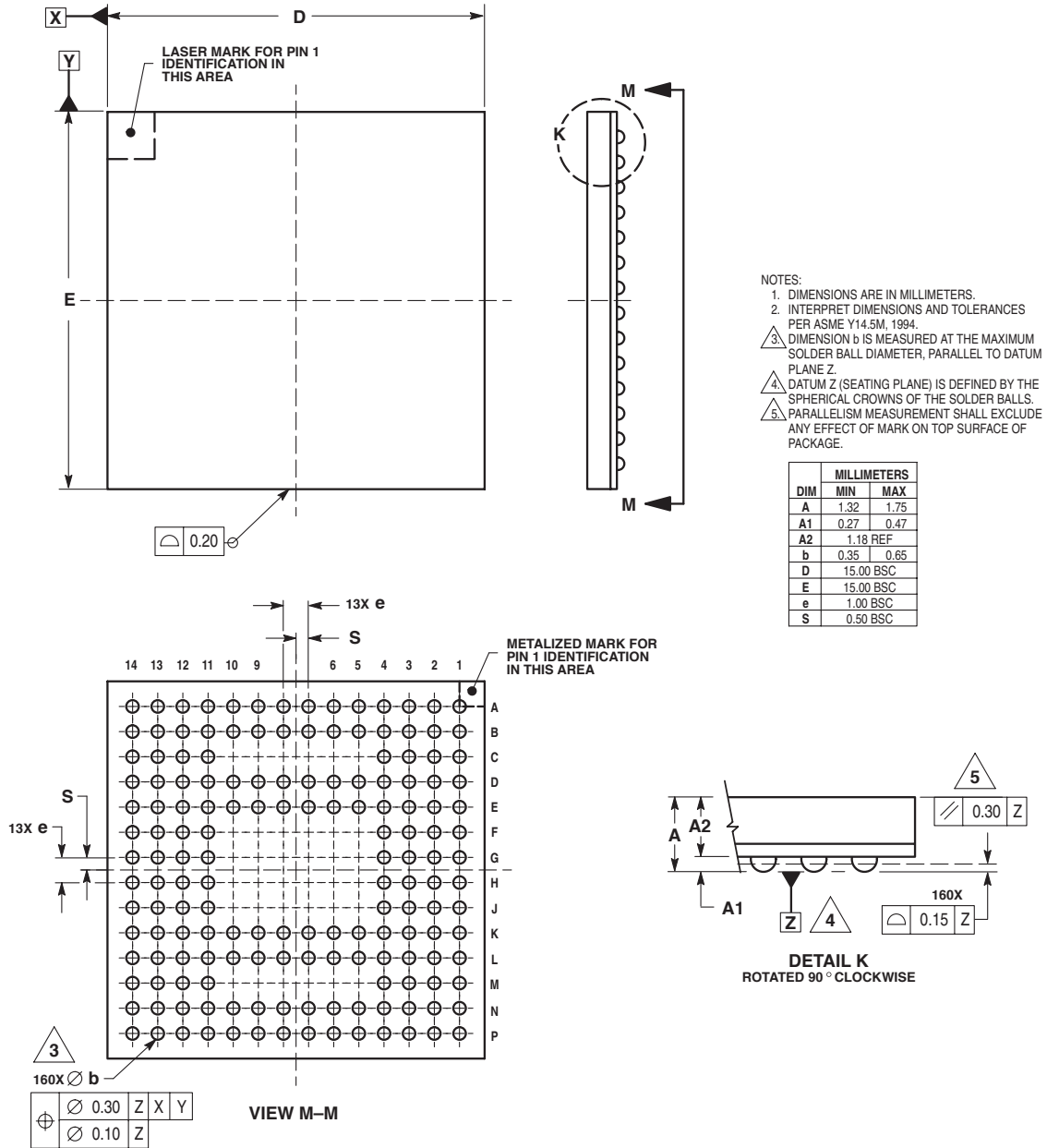

21.3 Wire Bond Information (MCW68HC08LK60)

21.3.1 Die Pad Coordinates

Table 21-1. Die Pad Coordinates (Sheet 1 of 5)

| Pad number | Pad function | X (microns) | X (mils) | Y (microns) | Y (mils) |
|------------|------------------|-------------|----------|-------------|----------|
| 1 | EV _{DD} | -2604.3 | -102.53 | 2519.4 | 99.19 |
| 2 | EV _{SS} | -2604.3 | -102.53 | 2386.8 | 93.97 |
| 3 | V _{DDA} | -2604.3 | -102.53 | 2254.2 | 88.75 |
| 4 | CGMXFC | -2604.3 | -102.53 | 2121.6 | 83.53 |
| 5 | OSC1 | -2604.3 | -102.53 | 1989 | 78.31 |
| 6 | OSC2 | -2604.3 | -102.53 | 1856.4 | 73.09 |
| 7 | V _{SSA} | -2604.3 | -102.53 | 1723.8 | 67.87 |
| 8 | V _{DD} | -2604.3 | -102.53 | 1591.2 | 62.65 |
| 9 | V _{SS} | -2604.3 | -102.53 | 1458.6 | 57.43 |
| 10 | LCDBP0 | -2604.3 | -102.53 | 1326 | 52.20 |
| 11 | LCDBP1 | -2604.3 | -102.53 | 1193.4 | 46.98 |
| 12 | LCDBP2 | -2604.3 | -102.53 | 1060.8 | 41.76 |
| 13 | LCDBP3 | -2604.3 | -102.53 | 928.2 | 36.54 |
| 14 | LCDFP1 | -2604.3 | -102.53 | 795.6 | 31.32 |
| 15 | LCDFP2 | -2604.3 | -102.53 | 663 | 26.10 |
| 16 | LCDFP3 | -2604.3 | -102.53 | 530.4 | 20.88 |
| 17 | LCDFP4 | -2604.3 | -102.53 | 397.8 | 15.66 |
| 18 | LCDFP5 | -2604.3 | -102.53 | 265.2 | 10.44 |
| 19 | LCDFP6 | -2604.3 | -102.53 | 132.6 | 5.22 |
| 20 | LCDFP7 | -2604.3 | -102.53 | 0 | 0.00 |
| 21 | LCDFP8 | -2604.3 | -102.53 | -132.6 | -5.22 |
| 22 | LCDFP9 | -2604.3 | -102.53 | -265.2 | -10.44 |
| 23 | LCDFP10 | -2604.3 | -102.53 | -397.8 | -15.66 |
| 24 | LCDFP11 | -2604.3 | -102.53 | -530.4 | -20.88 |
| 25 | LCDFP12 | -2604.3 | -102.53 | -663 | -26.10 |
| 26 | LCDFP13 | -2604.3 | -102.53 | -795.6 | -31.32 |
| 27 | LCDFP14 | -2604.3 | -102.53 | -928.2 | -36.54 |
| 28 | LCDFP15 | -2604.3 | -102.53 | -1060.8 | -41.76 |
| 29 | LCDFP16 | -2604.3 | -102.53 | -1193.4 | -46.98 |
| 30 | LCDFP17 | -2604.3 | -102.53 | -1326 | -52.20 |

Table 21-1. Die Pad Coordinates (Sheet 2 of 5)

| Pad number | Pad function | X (microns) | X (mils) | Y (microns) | Y (mils) |
|------------|-------------------|-------------|----------|-------------|----------|
| 31 | LCDFP18 | -2604.3 | -102.53 | -1458.6 | -57.43 |
| 32 | LCDFP19 | -2604.3 | -102.53 | -1591.2 | -62.65 |
| 33 | LCDFP20 | -2604.3 | -102.53 | -1723.8 | -67.87 |
| 34 | LCDFP21 | -2604.3 | -102.53 | -1856.4 | -73.09 |
| 35 | LCDFP22 | -2604.3 | -102.53 | -1989 | -78.31 |
| 36 | LCDFP23 | -2604.3 | -102.53 | -2121.6 | -83.53 |
| 37 | LCDFP24 | -2604.3 | -102.53 | -2254.2 | -88.75 |
| 38 | LCDFP25 | -2604.3 | -102.53 | -2386.8 | -93.97 |
| 39 | LCDFP26 | -2604.3 | -102.53 | -2519.4 | -99.19 |
| 40 | LCDFP27 | -2320.5 | -91.36 | -2803.2 | -110.36 |
| 41 | LCDFP28 | -2187.9 | -86.14 | -2803.2 | -110.36 |
| 42 | LCDFP29 | -2055.3 | -80.92 | -2803.2 | -110.36 |
| 43 | LCDFP30 | -1922.7 | -75.70 | -2803.2 | -110.36 |
| 44 | LCDFP31 | -1790.1 | -70.48 | -2803.2 | -110.36 |
| 45 | LCDFP32 | -1657.5 | -65.26 | -2803.2 | -110.36 |
| 46 | LCDFP33 | -1524.9 | -60.04 | -2803.2 | -110.36 |
| 47 | LCDFP34 | -1392.3 | -54.81 | -2803.2 | -110.36 |
| 48 | LCDFP35 | -1259.7 | -49.59 | -2803.2 | -110.36 |
| 49 | LCDFP36 | -1127.1 | -44.37 | -2803.2 | -110.36 |
| 50 | LCDFP37 | -994.5 | -39.15 | -2803.2 | -110.36 |
| 51 | LCDFP38 | -861.9 | -33.93 | -2803.2 | -110.36 |
| 52 | LCDFP39 | -729.3 | -28.71 | -2803.2 | -110.36 |
| 53 | LCDFP40 | -596.7 | -23.49 | -2803.2 | -110.36 |
| 54 | LCDFP41 | -464.1 | -18.27 | -2803.2 | -110.36 |
| 55 | LCDFP42 | -331.5 | -13.05 | -2803.2 | -110.36 |
| 56 | LCDFP43 | -198.9 | -7.83 | -2803.2 | -110.36 |
| 57 | V _{LL} | -66.3 | -2.61 | -2803.2 | -110.36 |
| 58 | VCP1 | 66.3 | 2.61 | -2803.2 | -110.36 |
| 59 | VCP2 | 198.9 | 7.83 | -2803.2 | -110.36 |
| 60 | VCP3 | 331.5 | 13.05 | -2803.2 | -110.36 |
| 61 | VCP4 | 464.1 | 18.27 | -2803.2 | -110.36 |
| 62 | V _{LL12} | 596.7 | 23.49 | -2803.2 | -110.36 |
| 63 | V _{LL32} | 729.3 | 28.71 | -2803.2 | -110.36 |
| 64 | LCDFP44 | 861.9 | 33.93 | -2803.2 | -110.36 |

Table 21-1. Die Pad Coordinates (Sheet 3 of 5)

| Pad number | Pad function | X (microns) | X (mils) | Y (microns) | Y (mils) |
|------------|--------------|-------------|----------|-------------|----------|
| 65 | LCDFP45 | 994.5 | 39.15 | -2803.2 | -110.36 |
| 66 | LCDFP46 | 1127.1 | 44.37 | -2803.2 | -110.36 |
| 67 | LCDFP47 | 1259.7 | 49.59 | -2803.2 | -110.36 |
| 68 | LCDFP48 | 1392.3 | 54.81 | -2803.2 | -110.36 |
| 69 | LCDFP49 | 1524.9 | 60.04 | -2803.2 | -110.36 |
| 70 | LCDFP50 | 1657.5 | 65.26 | -2803.2 | -110.36 |
| 71 | LCDFP51 | 1790.1 | 70.48 | -2803.2 | -110.36 |
| 72 | LCDFP52 | 1922.7 | 75.70 | -2803.2 | -110.36 |
| 73 | LCDFP53 | 2055.3 | 80.92 | -2803.2 | -110.36 |
| 74 | LCDFP54 | 2187.9 | 86.14 | -2803.2 | -110.36 |
| 75 | LCDFP55 | 2320.5 | 91.36 | -2803.2 | -110.36 |
| 76 | LCDFP56 | 2604.3 | 102.53 | -2519.4 | -99.19 |
| 77 | LCDFP57 | 2604.3 | 102.53 | -2386.8 | -93.97 |
| 78 | LCDFP58 | 2604.3 | 102.53 | -2254.2 | -88.75 |
| 79 | LCDFP59 | 2604.3 | 102.53 | -2121.6 | -83.53 |
| 80 | LCDFP60 | 2604.3 | 102.53 | -1989 | -78.31 |
| 81 | LCDFP61 | 2604.3 | 102.53 | -1856.4 | -73.09 |
| 82 | LCDFP62 | 2604.3 | 102.53 | -1723.8 | -67.87 |
| 83 | LCDFP63 | 2604.3 | 102.53 | -1591.2 | -62.65 |
| 84 | LCDFP64 | 2604.3 | 102.53 | -1458.6 | -57.43 |
| 85 | LCDFP65 | 2604.3 | 102.53 | -1326 | -52.20 |
| 86 | LCDFP66 | 2604.3 | 102.53 | -1193.4 | -46.98 |
| 87 | LCDFP67 | 2604.3 | 102.53 | -1060.8 | -41.76 |
| 88 | LCDFP68 | 2604.3 | 102.53 | -928.2 | -36.54 |
| 89 | LCDFP69 | 2604.3 | 102.53 | -795.6 | -31.32 |
| 90 | LCDFP70 | 2604.3 | 102.53 | -663 | -26.10 |
| 91 | LCDFP71 | 2604.3 | 102.53 | -530.4 | -20.88 |
| 92 | LCDFP72 | 2604.3 | 102.53 | -397.8 | -15.66 |
| 93 | LCDFP73 | 2604.3 | 102.53 | -265.2 | -10.44 |
| 94 | LCDFP74 | 2604.3 | 102.53 | -132.6 | -5.22 |
| 95 | LCDFP75 | 2604.3 | 102.53 | 0 | 0.00 |
| 96 | LCDFP76 | 2604.3 | 102.53 | 132.6 | 5.22 |
| 97 | LCDFP77 | 2604.3 | 102.53 | 265.2 | 10.44 |
| 98 | LCDFP78 | 2604.3 | 102.53 | 397.8 | 15.66 |

Table 21-1. Die Pad Coordinates (Sheet 4 of 5)

| Pad number | Pad function | X (microns) | X (mils) | Y (microns) | Y (mils) |
|------------|------------------|-------------|----------|-------------|----------|
| 99 | LCDFP79 | 2604.3 | 102.53 | 530.4 | 20.88 |
| 100 | LCDFP80 | 2604.3 | 102.53 | 663 | 26.10 |
| 101 | LCDFP81 | 2604.3 | 102.53 | 795.6 | 31.32 |
| 102 | LCDFP82 | 2604.3 | 102.53 | 928.2 | 36.54 |
| 103 | LCDFP83 | 2604.3 | 102.53 | 1060.8 | 41.76 |
| 104 | LCDFP84 | 2604.3 | 102.53 | 1193.4 | 46.98 |
| 105 | LCDFP85 | 2604.3 | 102.53 | 1326 | 52.20 |
| 106 | LCDBP4 | 2604.3 | 102.53 | 1458.6 | 57.43 |
| 107 | LCDBP5 | 2604.3 | 102.53 | 1591.2 | 62.65 |
| 108 | LCDBP6 | 2604.3 | 102.53 | 1723.8 | 67.87 |
| 109 | LCDBP7 | 2604.3 | 102.53 | 1856.4 | 73.09 |
| 110 | V _{SS} | 2604.3 | 102.53 | 1989 | 78.31 |
| 111 | V _{DD} | 2604.3 | 102.53 | 2121.6 | 83.53 |
| 112 | ALERT | 2604.3 | 102.53 | 2254.2 | 88.75 |
| 113 | EKBIB | 2604.3 | 102.53 | 2386.8 | 93.97 |
| 114 | EV _{SS} | 2604.3 | 102.53 | 2519.4 | 99.19 |
| 115 | EV _{DD} | 2320.5 | 91.36 | 2803.2 | 110.36 |
| 116 | PTC0 | 2187.9 | 86.14 | 2803.2 | 110.36 |
| 117 | PTC1 | 2055.3 | 80.92 | 2803.2 | 110.36 |
| 118 | PTC2 | 1922.7 | 75.70 | 2803.2 | 110.36 |
| 119 | PTC3 | 1790.1 | 70.48 | 2803.2 | 110.36 |
| 120 | PTC4 | 1657.5 | 65.26 | 2803.2 | 110.36 |
| 121 | PTC5 | 1524.9 | 60.04 | 2803.2 | 110.36 |
| 122 | PTC6 | 1392.3 | 54.81 | 2803.2 | 110.36 |
| 123 | PTC7 | 1259.7 | 49.59 | 2803.2 | 110.36 |
| 124 | EV _{SS} | 1127.1 | 44.37 | 2803.2 | 110.36 |
| 125 | PTB0 | 994.5 | 39.15 | 2803.2 | 110.36 |
| 126 | PTB1 | 861.9 | 33.93 | 2803.2 | 110.36 |
| 127 | PTB2 | 729.3 | 28.71 | 2803.2 | 110.36 |
| 128 | PTB3 | 596.7 | 23.49 | 2803.2 | 110.36 |
| 129 | PTB4 | 464.1 | 18.27 | 2803.2 | 110.36 |
| 130 | PTB5 | 331.5 | 13.05 | 2803.2 | 110.36 |
| 131 | PTB6 | 198.9 | 7.83 | 2803.2 | 110.36 |
| 132 | PTB7 | 66.3 | 2.61 | 2803.2 | 110.36 |

Table 21-1. Die Pad Coordinates (Sheet 5 of 5)

| Pad number | Pad function | X (microns) | X (mils) | Y (microns) | Y (mils) |
|------------|------------------|-------------|----------|-------------|----------|
| 133 | PTA0 | -66.3 | -2.61 | 2803.2 | 110.36 |
| 134 | PTA1 | -198.9 | -7.83 | 2803.2 | 110.36 |
| 135 | PTA2 | -331.5 | -13.05 | 2803.2 | 110.36 |
| 136 | PTA3 | -464.1 | -18.27 | 2803.2 | 110.36 |
| 137 | PTA4 | -596.7 | -23.49 | 2803.2 | 110.36 |
| 138 | PTA5 | -729.3 | -28.71 | 2803.2 | 110.36 |
| 139 | PTA6 | -861.9 | -33.93 | 2803.2 | 110.36 |
| 140 | PTA7 | -994.5 | -39.15 | 2803.2 | 110.36 |
| 141 | IRQ2B | -1127.1 | -44.37 | 2803.2 | 110.36 |
| 142 | IRQ1B | -1259.7 | -49.59 | 2803.2 | 110.36 |
| 143 | EV _{SS} | -1392.3 | -54.81 | 2803.2 | 110.36 |
| 144 | SCK | -1524.9 | -60.04 | 2803.2 | 110.36 |
| 145 | MOSI | -1657.5 | -65.26 | 2803.2 | 110.36 |
| 146 | MISO | -1790.1 | -70.48 | 2803.2 | 110.36 |
| 147 | SSB | -1922.7 | -75.70 | 2803.2 | 110.36 |
| 148 | TDO | -2055.3 | -80.92 | 2803.2 | 110.36 |
| 149 | TDI | -2187.9 | -86.14 | 2803.2 | 110.36 |
| 150 | RSTB | -2320.5 | -91.36 | 2803.2 | 110.36 |

21.3.2 Die Layout

68HC08LK60 DIE LAYOUT

MASK SET K57A

DIE SIZE 225.98 x 241.73 mils

Wafer FlatOrientation : Bottom ->

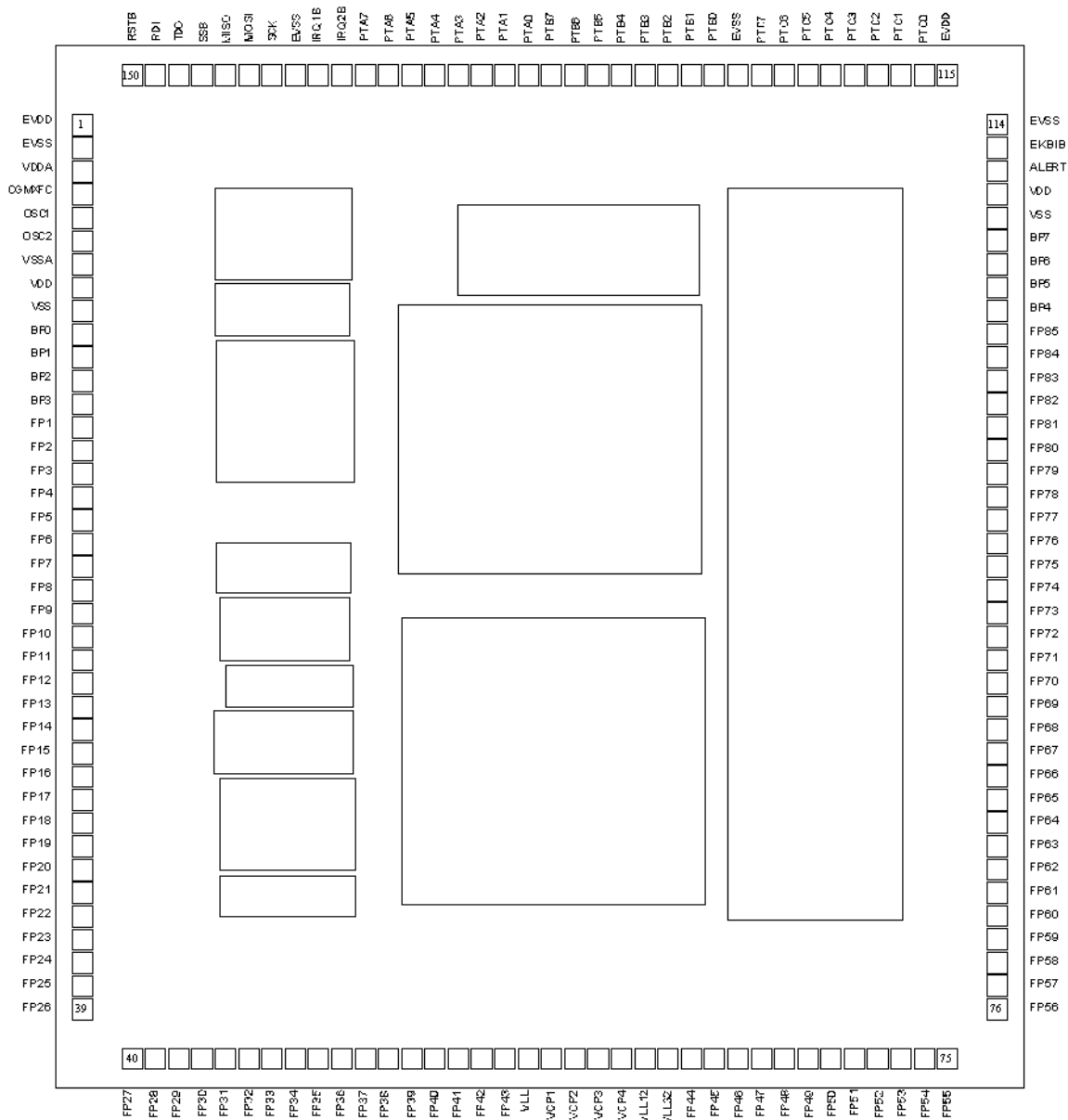
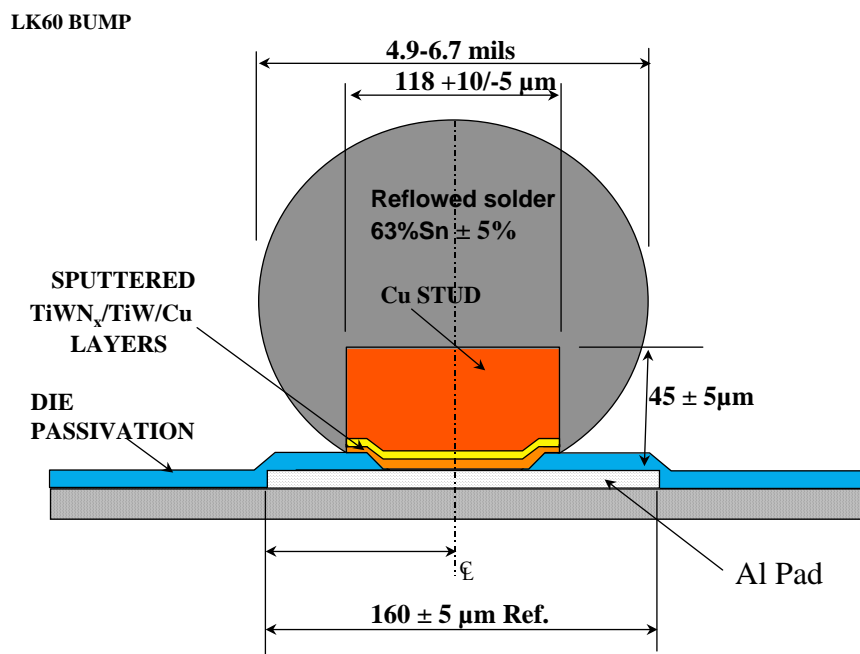

Figure 21-1. 68HC08LK60 Die Layout

21.4 Bump Wafer Information (MCCF68HC08LK60)

21.4.1 Bump Specification



SMD Electroplated Bump : Dimensions Before Probe

Figure 21-2. Bump Specification

21.4.2 Bumped Wafer Pad Coordinates

Table 21-2. Bump Coordinates (Sheet 1 of 5)

| Bump pad number | Bump pad name | X (microns) | X (mils) | Y (microns) | Y (mils) |
|-----------------|------------------|-------------|----------|-------------|----------|
| 1 | EV _{DD} | -2006.6 | -79.00 | 1728 | 68.03 |
| 2 | EV _{SS} | -1066.8 | -42.00 | 812 | 31.97 |
| 3 | V _{DDA} | -2413 | -95.00 | 2336 | 91.97 |
| 4 | CGMXFC | -2413 | -95.00 | 2082 | 81.97 |
| 5 | OSC1 | -2006.6 | -79.00 | 1474 | 58.03 |
| 6 | OSC2 | -1066.8 | -42.00 | 50 | 1.97 |
| 7 | V _{SSA} | -1066.8 | -42.00 | 558 | 21.97 |
| 8 | V _{DD} | -2413 | -95.00 | 1474 | 58.03 |
| 9 | V _{SS} | -1066.8 | -42.00 | 304 | 11.97 |
| 10 | LCDBP0 | -2413 | -95.00 | 1728 | 68.03 |
| 11 | LCDBP1 | -2413 | -95.00 | 1220 | 48.03 |
| 12 | LCDBP2 | -2006.6 | -79.00 | 1220 | 48.03 |
| 13 | LCDBP3 | -2413 | -95.00 | 966 | 38.03 |
| 14 | LCDFP1 | -2413 | -95.00 | 712 | 28.03 |
| 15 | LCDFP2 | -2006.6 | -79.00 | 966 | 38.03 |
| 16 | LCDFP3 | -2413 | -95.00 | 458 | 18.03 |
| 17 | LCDFP4 | -2006.6 | -79.00 | 712 | 28.03 |
| 18 | LCDFP5 | -2413 | -95.00 | 204 | 8.03 |
| 19 | LCDFP6 | -2006.6 | -79.00 | 458 | 18.03 |
| 20 | LCDFP7 | -2413 | -95.00 | -50 | -1.97 |
| 21 | LCDFP8 | -2006.6 | -79.00 | 204 | 8.03 |
| 22 | LCDFP9 | -2413 | -95.00 | -304 | -11.97 |
| 23 | LCDFP10 | -2006.6 | -79.00 | -50 | -1.97 |
| 24 | LCDFP11 | -2413 | -95.00 | -558 | -21.97 |
| 25 | LCDFP12 | -2006.6 | -79.00 | -304 | -11.97 |
| 26 | LCDFP13 | -2413 | -95.00 | -812 | -31.97 |
| 27 | LCDFP14 | -2006.6 | -79.00 | -558 | -21.97 |
| 28 | LCDFP15 | -2413 | -95.00 | -1066 | -41.97 |
| 29 | LCDFP16 | -2006.6 | -79.00 | -812 | -31.97 |
| 30 | LCDFP17 | -2413 | -95.00 | -1320 | -51.97 |
| 31 | LCDFP18 | -2006.6 | -79.00 | -1066 | -41.97 |
| 32 | LCDFP19 | -2413 | -95.00 | -1574 | -61.97 |

Table 21-2. Bump Coordinates (Sheet 2 of 5)

| Bump pad number | Bump pad name | X (microns) | X (mils) | Y (microns) | Y (mils) |
|-----------------|-------------------|-------------|----------|-------------|----------|
| 33 | LCDFP20 | -2006.6 | -79.00 | -1320 | -51.97 |
| 34 | LCDFP21 | -2413 | -95.00 | -1828 | -71.97 |
| 35 | LCDFP22 | -2006.6 | -79.00 | -1574 | -61.97 |
| 36 | LCDFP23 | -2413 | -95.00 | -2082 | -81.97 |
| 37 | LCDFP24 | -1066.8 | -42.00 | -204 | -8.03 |
| 38 | LCDFP25 | -2413 | -95.00 | -2336 | -91.97 |
| 39 | LCDFP26 | -2006.6 | -79.00 | -1828 | -71.97 |
| 40 | LCDFP27 | -1651 | -65.00 | -2183.6 | -85.97 |
| 41 | LCDFP28 | -2159 | -85.00 | -2590 | -101.97 |
| 42 | LCDFP29 | -1066.8 | -42.00 | -458 | -18.03 |
| 43 | LCDFP30 | -1905 | -75.00 | -2590 | -101.97 |
| 44 | LCDFP31 | -1397 | -55.00 | -2183.6 | -85.97 |
| 45 | LCDFP32 | -1651 | -65.00 | -2590 | -101.97 |
| 46 | LCDFP33 | -1066.8 | -42.00 | -712 | -28.03 |
| 47 | LCDFP34 | -1397 | -55.00 | -2590 | -101.97 |
| 48 | LCDFP35 | -1143 | -45.00 | -2183.6 | -85.97 |
| 49 | LCDFP36 | -1143 | -45.00 | -2590 | -101.97 |
| 50 | LCDFP37 | -889 | -35.00 | -2183.6 | -85.97 |
| 51 | LCDFP38 | -889 | -35.00 | -2590 | -101.97 |
| 52 | LCDFP39 | -635 | -25.00 | -2183.6 | -85.97 |
| 53 | LCDFP40 | -635 | -25.00 | -2590 | -101.97 |
| 54 | LCDFP41 | -381 | -15.00 | -2183.6 | -85.97 |
| 55 | LCDFP42 | -381 | -15.00 | -2590 | -101.97 |
| 56 | LCDFP43 | -127 | -5.00 | -2183.6 | -85.97 |
| 57 | V _{LL} | -127 | -5.00 | -2590 | -101.97 |
| 58 | VCP1 | 127 | 5.00 | -2590 | -101.97 |
| 59 | VCP2 | 127 | 5.00 | -2183.6 | -85.97 |
| 60 | VCP3 | 381 | 15.00 | -2590 | -101.97 |
| 61 | VCP4 | 381 | 15.00 | -2183.6 | -85.97 |
| 62 | V _{LL12} | 635 | 25.00 | -2590 | -101.97 |
| 63 | V _{LL32} | 635 | 25.00 | -2183.6 | -85.97 |
| 64 | LCDFP44 | 889 | 35.00 | -2590 | -101.97 |
| 65 | LCDFP45 | 889 | 35.00 | -2183.6 | -85.97 |
| 66 | LCDFP46 | 1066.8 | 42.00 | 304 | 11.97 |

Table 21-2. Bump Coordinates (Sheet 3 of 5)

| Bump pad number | Bump pad name | X (microns) | X (mils) | Y (microns) | Y (mils) |
|-----------------|---------------|-------------|----------|-------------|----------|
| 67 | LCDFP47 | 1143 | 45.00 | -2590 | -101.97 |
| 68 | LCDFP48 | 1143 | 45.00 | -2183.6 | -85.97 |
| 69 | LCDFP49 | 1397 | 55.00 | -2590 | -101.97 |
| 70 | LCDFP50 | 1066.8 | 42.00 | 50 | 1.97 |
| 71 | LCDFP51 | 1651 | 65.00 | -2590 | -101.97 |
| 72 | LCDFP52 | 1905 | 75.00 | -2590 | -101.97 |
| 73 | LCDFP53 | 1397 | 55.00 | -2183.6 | -85.97 |
| 74 | LCDFP54 | 2159 | 85.00 | -2590 | -101.97 |
| 75 | LCDFP55 | 1651 | 65.00 | -2183.6 | -85.97 |
| 76 | LCDFP56 | 1066.8 | 42.00 | 558 | 21.97 |
| 77 | LCDFP57 | 1066.8 | 42.00 | 812 | 31.97 |
| 78 | LCDFP58 | 2413 | 95.00 | -2236 | -88.03 |
| 79 | LCDFP59 | 2006.6 | 79.00 | -1728 | -68.03 |
| 80 | LCDFP60 | 2413 | 95.00 | -1982 | -78.03 |
| 81 | LCDFP61 | 2006.6 | 79.00 | -1474 | -58.03 |
| 82 | LCDFP62 | 2413 | 95.00 | -1728 | -68.03 |
| 83 | LCDFP63 | 2006.6 | 79.00 | -1220 | -48.03 |
| 84 | LCDFP64 | 2413 | 95.00 | -1474 | -58.03 |
| 85 | LCDFP65 | 2006.6 | 79.00 | -966 | -38.03 |
| 86 | LCDFP66 | 2413 | 95.00 | -1220 | -48.03 |
| 87 | LCDFP67 | 2006.6 | 79.00 | -712 | -28.03 |
| 88 | LCDFP68 | 2413 | 95.00 | -966 | -38.03 |
| 89 | LCDFP69 | 2006.6 | 79.00 | -458 | -18.03 |
| 90 | LCDFP70 | 2413 | 95.00 | -712 | -28.03 |
| 91 | LCDFP71 | 2006.6 | 79.00 | -204 | -8.03 |
| 92 | LCDFP72 | 2413 | 95.00 | -458 | -18.03 |
| 93 | LCDFP73 | 2413 | 95.00 | -204 | -8.03 |
| 94 | LCDFP74 | 2006.6 | 79.00 | 50 | 1.97 |
| 95 | LCDFP75 | 2413 | 95.00 | 50 | 1.97 |
| 96 | LCDFP76 | 2006.6 | 79.00 | 304 | 11.97 |
| 97 | LCDFP77 | 2413 | 95.00 | 304 | 11.97 |
| 98 | LCDFP78 | 2006.6 | 79.00 | 558 | 21.97 |
| 99 | LCDFP79 | 2413 | 95.00 | 558 | 21.97 |
| 100 | LCDFP80 | 2006.6 | 79.00 | 812 | 31.97 |

Table 21-2. Bump Coordinates (Sheet 4 of 5)

| Bump pad number | Bump pad name | X (microns) | X (mils) | Y (microns) | Y (mils) |
|-----------------|------------------|-------------|----------|-------------|----------|
| 101 | LCDFP81 | 2413 | 95.00 | 812 | 31.97 |
| 102 | LCDFP82 | 2006.6 | 79.00 | 1066 | 41.97 |
| 103 | LCDFP83 | 2413 | 95.00 | 1066 | 41.97 |
| 104 | LCDFP84 | 635 | 25.00 | 1243.8 | 48.97 |
| 105 | LCDFP85 | 2413 | 95.00 | 1320 | 51.97 |
| 106 | LCDBP4 | 2006.6 | 79.00 | 1320 | 51.97 |
| 107 | LCDBP5 | 2413 | 95.00 | 1574 | 61.97 |
| 108 | LCDBP6 | 381 | 15.00 | 1243.8 | 48.97 |
| 109 | LCDBP7 | 2413 | 95.00 | 1828 | 71.97 |
| 110 | V _{SS} | 2006.6 | 79.00 | 1574 | 61.97 |
| 111 | V _{DD} | 2413 | 95.00 | 2082 | 81.97 |
| 112 | ALERT | 127 | 5.00 | 1243.8 | 48.97 |
| 113 | EKBIB | 2413 | 95.00 | 2336 | 91.97 |
| 114 | EV _{SS} | 2006.6 | 79.00 | 1828 | 71.97 |
| 115 | EV _{DD} | 2159 | 85.00 | 2590 | 101.97 |
| 116 | PTC0 | -127 | -5.00 | 1243.8 | 48.97 |
| 117 | PTC1 | -381 | -15.00 | 1243.8 | 48.97 |
| 118 | PTC2 | 1905 | 75.00 | 2590 | 101.97 |
| 119 | PTC3 | 1651 | 65.00 | 2183.6 | 85.97 |
| 120 | PTC4 | 1651 | 65.00 | 2590 | 101.97 |
| 121 | PTC5 | 1397 | 55.00 | 2183.6 | 85.97 |
| 122 | PTC6 | 1397 | 55.00 | 2590 | 101.97 |
| 123 | PTC7 | 1143 | 45.00 | 2590 | 101.97 |
| 124 | EV _{SS} | 1143 | 45.00 | 2183.6 | 85.97 |
| 125 | PTB0 | 889 | 35.00 | 2183.6 | 85.97 |
| 126 | PTB1 | 889 | 35.00 | 2590 | 101.97 |
| 127 | PTB2 | 635 | 25.00 | 2183.6 | 85.97 |
| 128 | PTB3 | 635 | 25.00 | 2590 | 101.97 |
| 129 | PTB4 | 381 | 15.00 | 2183.6 | 85.97 |
| 130 | PTB5 | 381 | 15.00 | 2590 | 101.97 |
| 131 | PTB6 | 127 | 5.00 | 2590 | 101.97 |
| 132 | PTB7 | 127 | 5.00 | 2183.6 | 85.97 |
| 133 | PTA0 | -127 | -5.00 | 2590 | 101.97 |
| 134 | PTA1 | -127 | -5.00 | 2183.6 | 85.97 |

Table 21-2. Bump Coordinates (Sheet 5 of 5)

| Bump pad number | Bump pad name | X (microns) | X (mils) | Y (microns) | Y (mils) |
|-----------------|------------------|-------------|----------|-------------|----------|
| 135 | PTA2 | -381 | -15.00 | 2590 | 101.97 |
| 136 | PTA3 | -381 | -15.00 | 2183.6 | 85.97 |
| 137 | PTA4 | -635 | -25.00 | 2590 | 101.97 |
| 138 | PTA5 | -635 | -25.00 | 2183.6 | 85.97 |
| 139 | PTA6 | -889 | -35.00 | 2590 | 101.97 |
| 140 | PTA7 | -635 | -25.00 | 1243.8 | 48.97 |
| 141 | IRQ2B | -1143 | -45.00 | 2590 | 101.97 |
| 142 | IRQ1B | -889 | -35.00 | 2183.6 | 85.97 |
| 143 | EV _{SS} | -889 | -35.00 | 1243.8 | 48.97 |
| 144 | SCK | -1397 | -55.00 | 2590 | 101.97 |
| 145 | MOSI | -1651 | -65.00 | 2590 | 101.97 |
| 146 | MISO | -1143 | -45.00 | 2183.6 | 85.97 |
| 147 | SSB | -1905 | -75.00 | 2590 | 101.97 |
| 148 | TDO | -1397 | -55.00 | 2183.6 | 85.97 |
| 149 | RDI | -1651 | -65.00 | 2183.6 | 85.97 |
| 150 | RSTB | -2159 | -85.00 | 2590 | 101.97 |

21.4.3 Die Feature

68HC08LK60 DIE LAYOUT
60/40 PLATED EUTECTIC BUMP
TSC8 MASK SET K57A

225.98 x 241.73 mils

Wafer Flat Orientation: Bottom - >

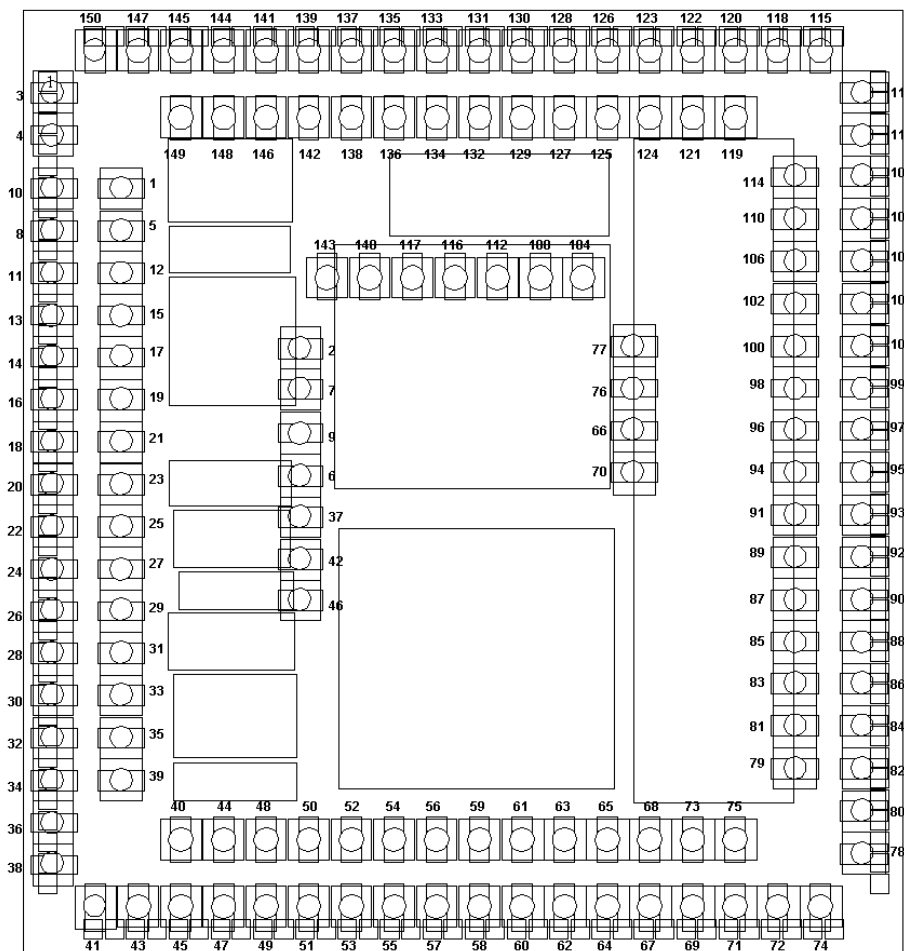
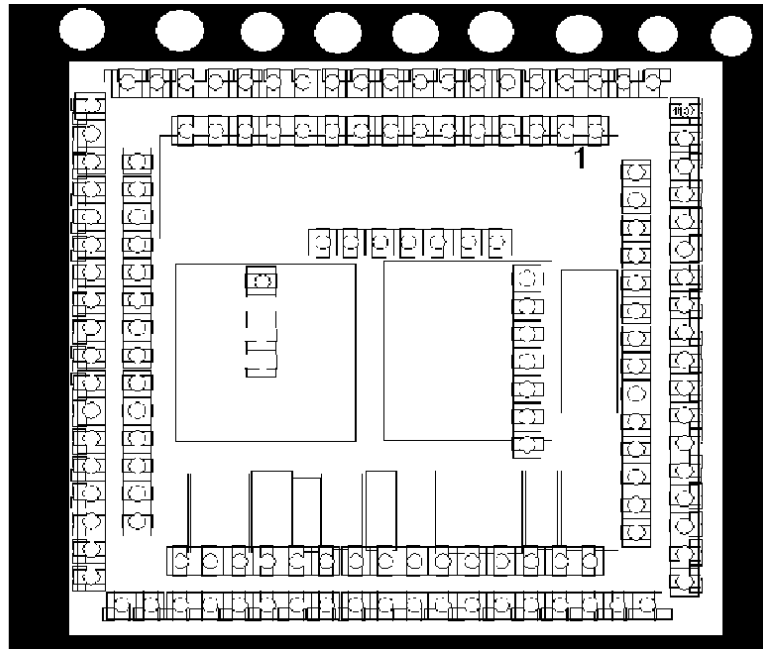

Figure 21-3. Bump Die Layout

21.4.4 Tape and Reel Die Orientation



NOTE: Active side down (bumps side), X-ray top view

Figure 21-4. Tape and Reel Die Orientation

Chapter 22

Ordering Information

22.1 Introduction

This section contains instructions for ordering the MC68HC(9)08LK60.

22.2 MC Order Numbers

Table 22-1. MC Order Numbers

| MC order number | Operating temperature range | Description |
|-----------------|-----------------------------|------------------|
| MC68HC08LK60VF | -20 to +65°C | BGA package |
| MCW68HC08LK60 | -20 to +65°C | Wafer sales |
| MCCF68HC08LK60 | -20 to +65°C | Bump wafer sales |

Note: Tested and guaranteed at room temperature only.

How to Reach Us:

Home Page:

www.freescale.com

E-mail:

support@freescale.com

USA/Europe or Locations Not Listed:

Freescale Semiconductor
Technical Information Center, CH370
1300 N. Alma School Road
Chandler, Arizona 85224
+1-800-521-6274 or +1-480-768-2130
support@freescale.com

Europe, Middle East, and Africa:

Freescale Halbleiter Deutschland GmbH
Technical Information Center
Schatzbogen 7
81829 Muenchen, Germany
+44 1296 380 456 (English)
+46 8 52200080 (English)
+49 89 92103 559 (German)
+33 1 69 35 48 48 (French)
support@freescale.com

Japan:

Freescale Semiconductor Japan Ltd.
Headquarters
ARCO Tower 15F
1-8-1, Shimo-Meguro, Meguro-ku,
Tokyo 153-0064
Japan
0120 191014 or +81 3 5437 9125
support.japan@freescale.com

Asia/Pacific:

Freescale Semiconductor Hong Kong Ltd.
Technical Information Center
2 Dai King Street
Tai Po Industrial Estate
Tai Po, N.T., Hong Kong
+800 2666 8080
support.asia@freescale.com

For Literature Requests Only:

Freescale Semiconductor Literature Distribution Center
P.O. Box 5405
Denver, Colorado 80217
1-800-441-2447 or 303-675-2140
Fax: 303-675-2150
LDCForFreescaleSemiconductor@hibbertgroup.com

RoHS-compliant and/or Pb- free versions of Freescale products have the functionality and electrical characteristics of their non-RoHS-compliant and/or non-Pb- free counterparts. For further information, see <http://www.freescale.com> or contact your Freescale sales representative.

For information on Freescale's Environmental Products program, go to <http://www.freescale.com/epp>.

Information in this document is provided solely to enable system and software implementers to use Freescale Semiconductor products. There are no express or implied copyright licenses granted hereunder to design or fabricate any integrated circuits or integrated circuits based on the information in this document.

Freescale Semiconductor reserves the right to make changes without further notice to any products herein. Freescale Semiconductor makes no warranty, representation or guarantee regarding the suitability of its products for any particular purpose, nor does Freescale Semiconductor assume any liability arising out of the application or use of any product or circuit, and specifically disclaims any and all liability, including without limitation consequential or incidental damages. "Typical" parameters that may be provided in Freescale Semiconductor data sheets and/or specifications can and do vary in different applications and actual performance may vary over time. All operating parameters, including "Typicals", must be validated for each customer application by customer's technical experts. Freescale Semiconductor does not convey any license under its patent rights nor the rights of others. Freescale Semiconductor products are not designed, intended, or authorized for use as components in systems intended for surgical implant into the body, or other applications intended to support or sustain life, or for any other application in which the failure of the Freescale Semiconductor product could create a situation where personal injury or death may occur. Should Buyer purchase or use Freescale Semiconductor products for any such unintended or unauthorized application, Buyer shall indemnify and hold Freescale Semiconductor and its officers, employees, subsidiaries, affiliates, and distributors harmless against all claims, costs, damages, and expenses, and reasonable attorney fees arising out of, directly or indirectly, any claim of personal injury or death associated with such unintended or unauthorized use, even if such claim alleges that Freescale Semiconductor was negligent regarding the design or manufacture of the part.

Freescale™ and the Freescale logo are trademarks of Freescale Semiconductor, Inc. All other product or service names are the property of their respective owners.

© Freescale Semiconductor, Inc. 2005. All rights reserved.