



TEA2208T

Active bridge rectifier controller

Rev. 1.4 — 14 April 2021

Product data sheet

1 General description

The TEA2208T is the first product of a new generation of active bridge rectifier controllers replacing the traditional diode bridge.

Using the TEA2208T with low-ohmic high-voltage external MOSFETs significantly improves the efficiency of the power converter as the typical rectifier diode-forward conduction losses are eliminated. Efficiency can improve up to about 1.4 % at 90 V (AC) mains voltage.

The TEA2208T is designed in a silicon-on insulator (SOI) process.

2 Features and benefits

2.1 Efficiency features

- Forward conduction losses of the diode rectifier bridge are eliminated
- Very low IC power consumption (2 mW).

2.2 Application features

- Integrated high-voltage level shifters
- Directly drives all four rectifier MOSFETs
- Very low external part count
- Integrated X-capacitor discharge (2 mA)
- Self-supplying
- Full-wave drive improving total harmonic distortion (THD)
- S014 package

2.3 Control features

- Undervoltage lockout (UVLO) for high-side and low-side drivers
- Drain-source overvoltage protection for all external power MOSFETs
- Gate pull-down currents at start-up for all external power MOSFETs



3 Applications

The TEA2208T is intended for power supplies with a boost-type power-factor controller as a first stage. The second stage can be a resonant controller, a flyback controller, or any other controller topology. It can be used in all power supplies requiring high efficiency:

- Adapters
- Power supplies for desktop PC and all-in-one PC
- Power supplies for television
- Power supplies for servers

4 Ordering information

Table 1. Ordering information

Type number	Package		Version
	Name	Description	
TEA2208T/1	SO14	plastic small outline package; 14 leads; body width 3.9 mm	SOT108-1

5 Marking

Table 2. Marking

Type number	Marking code
TEA2208T/1	TEA2208T

6 Block diagram

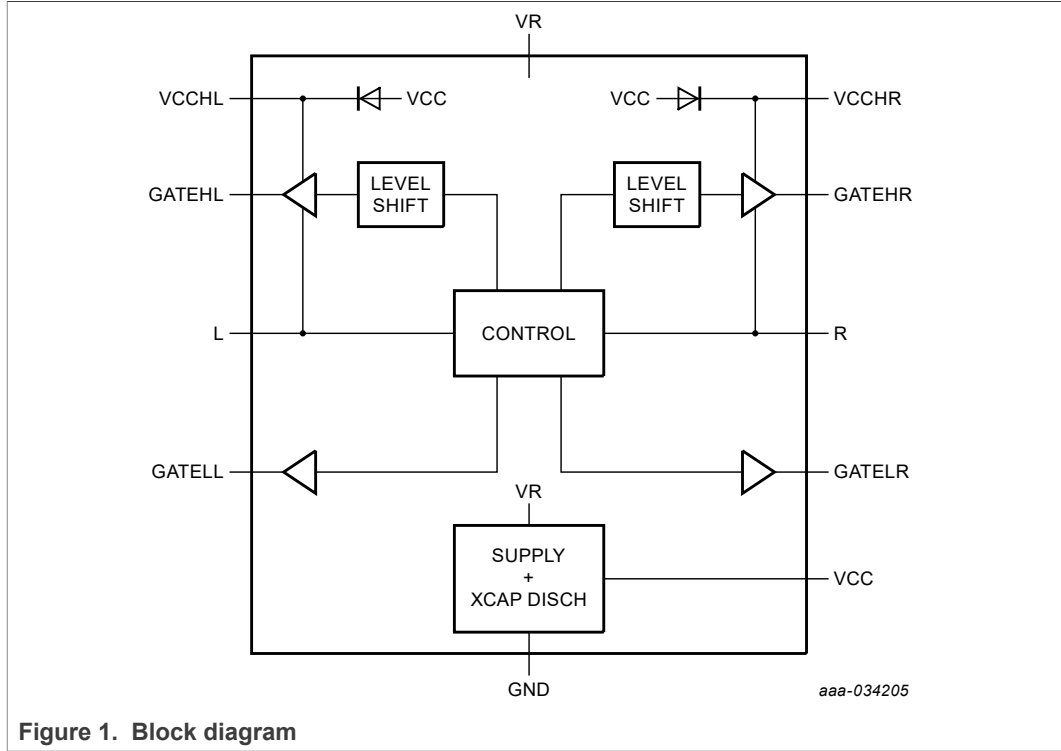

Figure 1. Block diagram

7 Pinning information

7.1 Pinning

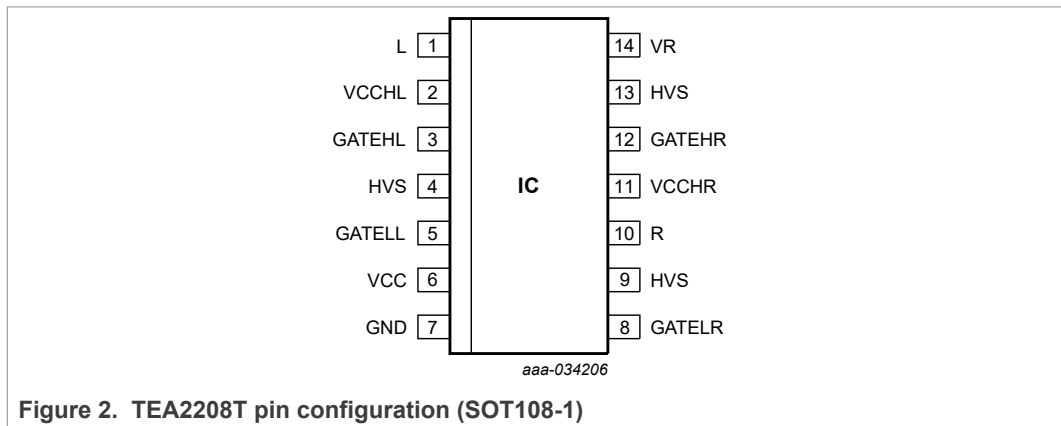

Figure 2. TEA2208T pin configuration (SOT108-1)

7.2 Pin description

Table 3. Pin description

Symbol	Pin	Description
L	1	left input, source of upper-left MOSFET
VCCHL	2	left high-side floating supply
GATEHL	3	gate driver left high side
HVS	4	high-voltage spacer; not to be connected
GATELL	5	gate driver left low side
VCC	6	supply voltage
GND	7	ground
GATELR	8	gate driver right low side
HVS	9	high-voltage spacer; not to be connected
R	10	right input, source of upper-right MOSFET
VCCHR	11	right high-side floating supply
GATEHR	12	gate driver right high side
HVS	13	high-voltage spacer; not to be connected
VR	14	rectified mains voltage

8 Functional description

8.1 Introduction

The TEA2208T is a controller IC for an active bridge rectifier. It can directly drive the four MOSFETs in an active bridge. Figure 3 shows a typical configuration. Since the output is a rectified sine wave, a boost-type power-factor circuit must follow the application.

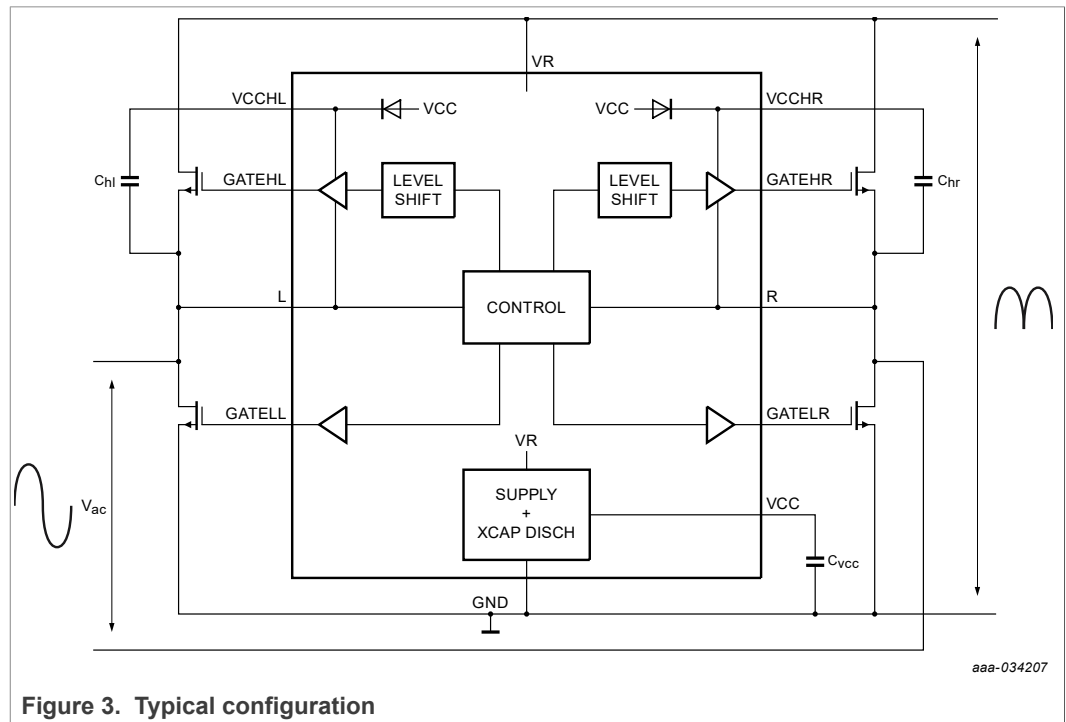

Figure 3. Typical configuration

8.2 Operation

The control circuit of the TEA2208T senses the polarity of the mains voltage between pins L and R. Depending on the polarity, diagonal pairs of power MOSFETs are switched on or off. Depending on the slope polarity, the comparator in the control circuit, which compares the L and R voltages, has thresholds of 250 mV and -250 mV.

The gate drivers are high-current rail-to-rail MOS output drivers. An on-chip supply circuit which draws current from the rectified sine-wave pin VR generates the gate driver voltage. After a zero-crossing of the mains voltage, the supply capacitor C_{VCC} is charged to the regulation level V_{reg} . Then the discharge state is entered. The resulting power dissipation from the mains voltage is about 1 mW, excluding gate charge losses of the external power MOSFETs. These gate charge losses typically add a 1 mW dissipation.

At start-up, the body diodes of the power MOSFETs act as a traditional diode bridge. They cause a peak rectified voltage at pin VR. From this high voltage, the supply capacitor is first charged to the V_{start} voltage and then enters the start-up state. After a next zero-crossing of the mains voltage, the supply capacitor is charged to V_{reg} in the charging state. When the voltage at the supply capacitor exceeds $V_{disable}$, the gate driver outputs are enabled. The high-side drivers start up later than the low-side drivers. The floating supplies must first be charged and the drain-source voltage of the high-side power MOSFETs must be less than the drain-source protection voltage. When all drivers

are active, the MOSFETs take over the role of the diodes. The result is a much lower power loss than a passive diode rectifier bridge.

In the discharge state, when the mains voltage is disconnected, the internal bias current discharges the supply capacitor. When the voltage at pin VCC drops to below $V_{disable}$ the X-capacitor discharge state is entered, which draws a 2 mA current from pin VR to discharge the X-capacitor. The waiting time, t_d until the X-capacitor discharge starts is:

$$T_{delay} = C_{VCC} * (V_{reg} - V_{disable}) / 20 \text{ uA} = 200k * C_{VCC} \tag{1}$$

Using a typical value of 2.2 μF for C_{VCC} yields about 0.45 s. While the VR pin discharges the X-capacitor, the mains can be reconnected. In that case, the charge mode is entered again.

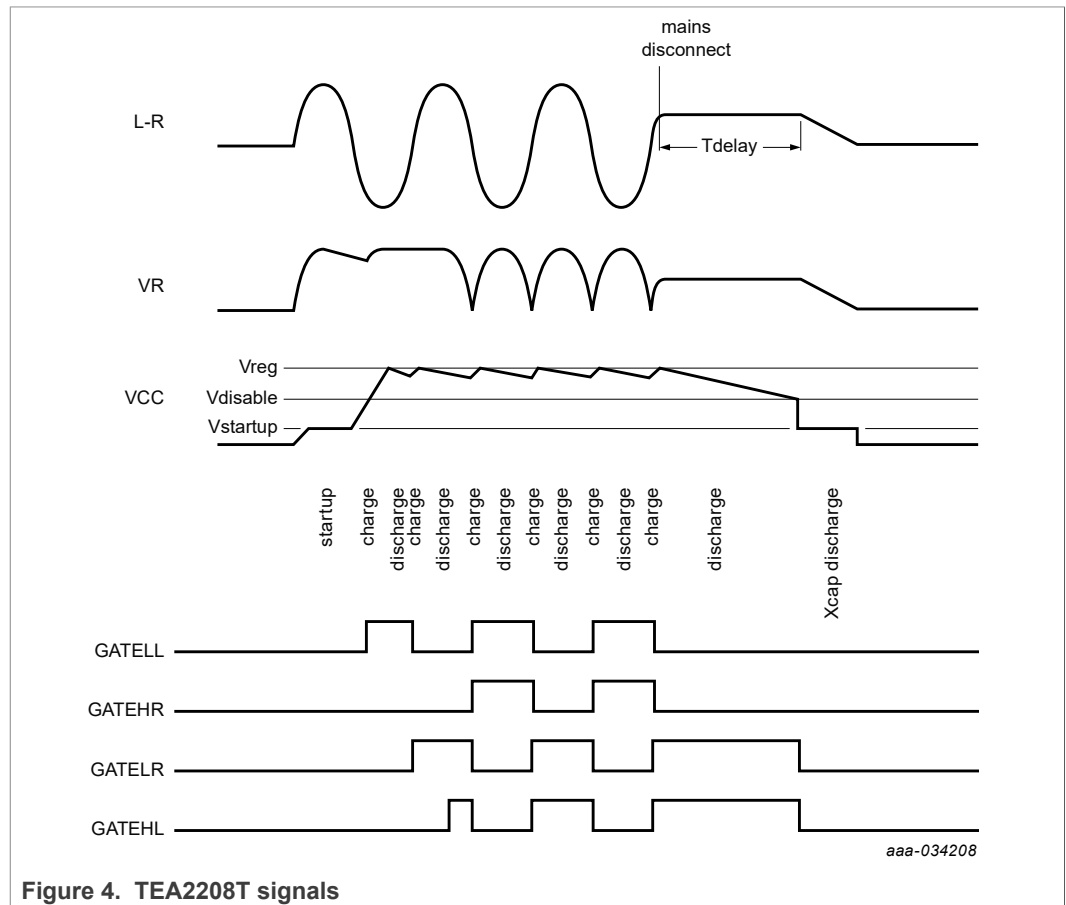

Figure 4. TEA2208T signals

Table 4. TEA2208T states

State	Description	I _{VR}	I _{VCC}
start-up	supply capacitor kept stable at 4.8 V	2 mA	0
charge	supply capacitor is charged from pin VR with 2 mA	+2 mA	-2 mA
discharge	Internal bias currents and gate charge losses discharge the supply capacitor	1 μ A	20 μ A
X-capacitor discharge	supply capacitor and X-capacitor at pin VR are discharged by 2 mA	2 mA	-2 mA

8.3 Protections

8.3.1 Gate pull-down

All gate driver outputs have a pull-down circuit. It ensures that, if a driver supply voltage is lower than the undervoltage lockout level, the discharge of the gate driver output discharges to less than 2 V.

8.3.2 Power MOSFET drain-source protection

If the drain-source voltage of the external power MOSFET exceeds $V_{CC} - 2$ V (low-side), $V_{CCHL} - 3.5$ V (high-side left), or $V_{CCHR} - 3.5$ V (high-side right), all gate driver outputs are disabled. Disabling the gate driver outputs avoids high dissipation and high current peaks in the power MOSFETs during start-up.

8.3.3 Minimum mains voltage

Only when the voltage at either node L or R exceeds 22 V, the charge state is entered.

9 Limiting values

Table 5. Limiting values

In accordance with the Absolute Maximum Rating System (IEC 60134). All voltages are measured with respect to ground (pin 7). Positive currents flow into the chip. Voltage ratings are valid provided other ratings are not violated. Current ratings are valid provided the other ratings are not violated.

Symbol	Parameter	Conditions	Min	Max	Unit
Voltages					
V _{VR}	voltage on pin VR	operating	-0.4	440	V
		mains transient: maximum 10 minutes over lifetime	-0.4	700	V
V _{VCCHL}	voltage on pin VCCHL	operating	-0.4	440	V
		mains transient: maximum 10 minutes over lifetime	-0.4	700	V
V _{VCCHR}	voltage on pin VCCHR	operating	-0.4	440	V
		mains transient: maximum 10 minutes over lifetime	-0.4	700	V
V _L	voltage on pin L	operating	-5	+440	V
		mains transient: maximum 10 minutes over lifetime	-5	+700	V
V _R	voltage on pin R	operating	-5	+440	V
		mains transient: maximum 10 minutes over lifetime	-5	+700	V
ΔV _(VR-L)	voltage difference between pins VR and L	operating	-10	+440	V
		mains transient: maximum 10 minutes over lifetime	-10	+700	V
ΔV _(VR-R)	voltage difference between pins VR and R	operating	-10	+440	V
		mains transient: maximum 10 minutes over lifetime	-10	+700	V
V _{GATEHR}	voltage on pin GATEHR	operating	-5	+440	V
		mains transient: maximum 10 minutes over lifetime	-5	+700	V
V _{GATEHL}	voltage on pin GATEHL	operating	-5	+440	V
		mains transient: maximum 10 minutes over lifetime	-5	+700	V

Table 5. Limiting values...continued

In accordance with the Absolute Maximum Rating System (IEC 60134). All voltages are measured with respect to ground (pin 7). Positive currents flow into the chip. Voltage ratings are valid provided other ratings are not violated. Current ratings are valid provided the other ratings are not violated.

Symbol	Parameter	Conditions	Min	Max	Unit
SR _{max}	maximum slew rate	pins VR, L, R, VCCHL, VCCHR, GATEHL, GATEHR	-	50	V/ns
V _{VCC}	voltage on pin VCC		-0.4	14	V
V _{GATELR}	voltage on pin GATELR		-0.4	14	V
V _{GATELL}	voltage on pin GATELL		-0.4	14	V
V _{DD(float)}	Float supply voltage	pins GATEHL-L, GATEHR-R, VCCHR-R, VCCHL-L	-0.4	14	V
General					
T _j	junction temperature		-40	+125	°C
T _{stg}	storage temperature		-55	+150	°C
Electrostatic discharge (ESD)					
V _{ESD}	electrostatic discharge voltage	human body model (HBM)			
		pins: VR, L,R,VCCHL, VCCHR, GATEHL, and GATEHR	-1000	+1000	V
		other pins	-2000	+2000	V
		charge device model (CDM)	-500	+500	V

10 Thermal characteristics

Table 6. Thermal characteristics

Symbol	Parameter	Conditions	Typ	Unit
R _{th(j-c)}	thermal resistance from junction to case	in free air ^[1]	43	K/W
R _{th(j-a)}	thermal resistance from junction to ambient	in free air; 1-layer PCB ^[1]	143	K/W
		in free air; 4-layer PCB; JEDEC test board ^[1]	105	K/W

[1] Given thermal resistance values are based on simulation results.

11 Characteristics

Table 7. Characteristics

$T_{amb} = 25\text{ }^{\circ}\text{C}$; all voltages are measured with respect to GND; currents are positive when flowing into the IC; unless otherwise specified.

Symbol	Parameter	Conditions	Min	Typ	Max	Unit
VR pin						
I_{on}	on-state current	Charging state; X-capacitor discharge state; start-up state	1.5	2	2.75	mA
I_{off}	off-state current	discharge state	0.5	0.8	1.2	μA
V_{start}	start voltage	high-voltage start-up	9	-	-	V
VCC pin						
I_{dch}	discharge current	X-capacitor discharge	3	4	5.5	mA
I_{bias}	bias current	discharge state	15	20	30	μA
I_{ch}	charge current	charge state	1.5	2	2.75	mA
V_{UVLO}	undervoltage lockout voltage		3.6	4.2	4.9	V
$V_{startup}$	start-up voltage	start-up state	4.3	4.8	5.3	V
V_{dis}	disable voltage	high level	9.2	9.7	10.2	V
		hysteresis	1.1	1.5	1.8	V
V_{regd}	regulated output voltage		11.4	12	12.8	V
Floating supply pins (VCCHL, VCCHR)						
$I_{I(VCCHL)}$	input current on pin VCCHL	$V_L = 0\text{ V}$	1.4	1.8	2.5	μA
		$V_L = 200\text{ V}$	4	7	12	μA
$I_{I(VCCHR)}$	input current on pin VCCHR	$V_R = 0\text{ V}$	1.4	1.8	2.5	μA
		$V_R = 200\text{ V}$	4	7	12	μA
$V_{DD(float)UVLO}$	float supply undervoltage lockout voltage		3.6	4.2	5.0	V
$V_{d(bs)}$	bootstrap diode voltage	current on diode = 1 mA	0.8	1	1.3	V
Gate driver output pins (GATELL, GATELR, GATEHL, GATEHR)						
I_{source}	source current	$V_{VCC} = 12\text{ V};$ $V_{GATELL} = V_{GATEHL} = 6\text{ V};$ $V_{GATELR} = V_{GATEHR} = 6\text{ V}$	[1] 125	200	400	mA
I_{sink}	sink current	$V_{VCC} = 12\text{ V};$ $V_{GATELL} = V_{GATEHL} = 6\text{ V};$ $V_{GATELR} = V_{GATEHR} = 6\text{ V}$	[1] 150	200	500	mA
I_{pd}	pull-down current	off-state current; $V_{VCC} = 2\text{ V};$ $V_{GATELL} = V_{GATEHL} = 2\text{ V};$ $V_{GATELR} = V_{GATEHR} = 2\text{ V}$	100	200	250	μA
R_{on}	on-state resistance		11	15	20	Ω
R_{off}	off-state resistance		7	10	14	Ω

Table 7. Characteristics...continued

$T_{amb} = 25\text{ }^{\circ}\text{C}$; all voltages are measured with respect to GND; currents are positive when flowing into the IC; unless otherwise specified.

Symbol	Parameter	Conditions	Min	Typ	Max	Unit
V _{prot(G)}	gate driver protection voltage	VR-VCCHR; VR-VCCHL	-5	-3.5	-2	V
		L-VCC; R-VCC	-3	-2.3	-1	V
Control circuit (pin L and R)						
V _{th}	threshold voltage	peak detector threshold voltage	15	22	32	V
I _{det}	detection current	peak detector current	0.4	0.5	0.6	μA
V _{offset}	offset voltage	zero-crossing comparator offset voltage	150	250	350	mV
t _d	delay time	zero-crossing comparator delay time				
		dV/dt = 0.1 V/μs ^[2]	1200	1500	2500	ns
		dV/dt = 10 V/μs ^[2]	550	700	1200	ns

[1] Covered by correlating measurement.

[2] Covered by design and validation.

12 Application information

A switched-mode power supply (SMPS) with the TEA2208T typically consists of a mains filter in front of the TEA2208T followed by a boost-type power factor controller. A resonant controller, flyback controller, or any other topology can follow this boost-type PFC.

Special attention must be given to the connection of the VR, L, and R pins of the TEA2208T. Mains transients or surges must be limited to voltages below 700 V. Placing an additional metal-oxide varistor (MOV) after the mains filter may be required. Adding diodes from pins L and R to the boost capacitor of the boost-type PFC may also be necessary. As mains transient currents can be high, the PCB tracks must have a suitable width. Inductance (track length) must be minimized.

Typical values for the three external capacitors are 1 μF to 2.2 μF (supply capacitor) and 100 nF to 220 nF (bootstrap capacitors). Supply capacitors with higher values increase the delay time (t_d) for the X-capacitor discharge. They may also increase the dissipation because the supply capacitor C_{VCC} may not be charged every half-mains cycle. Bootstrap capacitors with lower value may cause a voltage drop that is too high because of the gate charge losses.

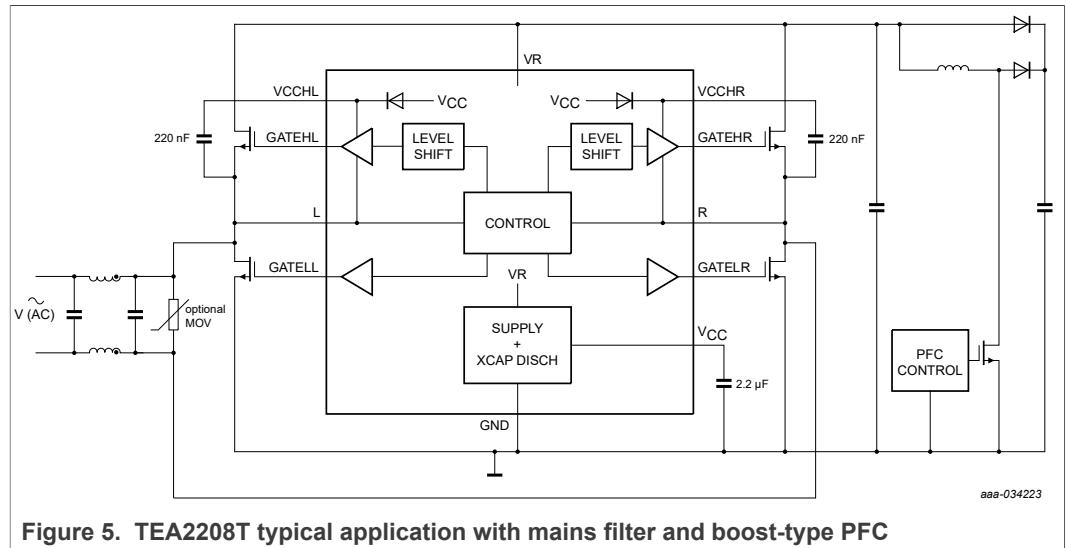

Figure 5. TEA2208T typical application with mains filter and boost-type PFC

13 Package outline

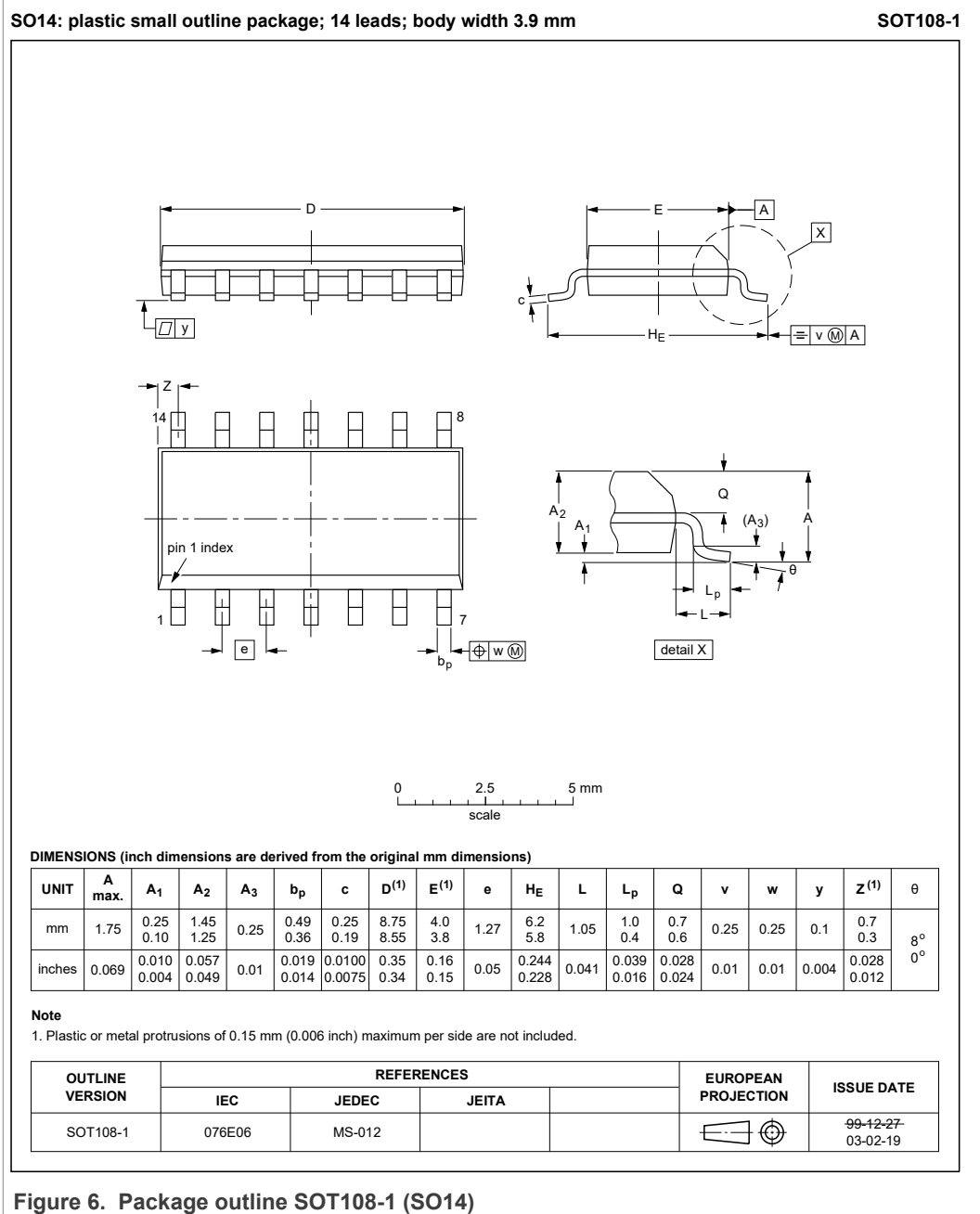

Figure 6. Package outline SOT108-1 (SO14)

14 Abbreviations

Table 8. Abbreviations

Acronym	Description
CDM	change device model
ESD	electrostatic discharge
HBM	human body model
MOSFET	metal–oxide–semiconductor field-effect transistor
MOV	metal-oxide varistor
PFC	power-factor controller
SMPS	switched-mode power supply
SOI	silicon-on insulator
THD	total harmonic distortion
UVLO	undervoltage lockout

15 Revision history

Table 9. Revision history

Document ID	Release date	Data sheet status	Change notice	Supersedes
TEA2208T v.1.4	20210414	Product data sheet	-	TEA2208T v.1.3
Modifications:	• Section 11 "Characteristics" has been updated.			
TEA2208T v.1.3	20201216	Product data sheet	-	TEA2208T v.1.2
TEA2208T v.1.2	20201029	Product data sheet	-	TEA2208T v.1.1
TEA2208T v.1.1	20200325	Product data sheet	-	TEA2208T v.1
TEA2208T v.1	20191019	Product data sheet	-	-

16 Legal information

16.1 Data sheet status

Document status ^{[1][2]}	Product status ^[3]	Definition
Objective [short] data sheet	Development	This document contains data from the objective specification for product development.
Preliminary [short] data sheet	Qualification	This document contains data from the preliminary specification.
Product [short] data sheet	Production	This document contains the product specification.

[1] Please consult the most recently issued document before initiating or completing a design.

[2] The term 'short data sheet' is explained in section "Definitions".

[3] The product status of device(s) described in this document may have changed since this document was published and may differ in case of multiple devices. The latest product status information is available on the Internet at URL <http://www.nxp.com>.

16.2 Definitions

Draft — A draft status on a document indicates that the content is still under internal review and subject to formal approval, which may result in modifications or additions. NXP Semiconductors does not give any representations or warranties as to the accuracy or completeness of information included in a draft version of a document and shall have no liability for the consequences of use of such information.

Short data sheet — A short data sheet is an extract from a full data sheet with the same product type number(s) and title. A short data sheet is intended for quick reference only and should not be relied upon to contain detailed and full information. For detailed and full information see the relevant full data sheet, which is available on request via the local NXP Semiconductors sales office. In case of any inconsistency or conflict with the short data sheet, the full data sheet shall prevail.

Product specification — The information and data provided in a Product data sheet shall define the specification of the product as agreed between NXP Semiconductors and its customer, unless NXP Semiconductors and customer have explicitly agreed otherwise in writing. In no event however, shall an agreement be valid in which the NXP Semiconductors product is deemed to offer functions and qualities beyond those described in the Product data sheet.

16.3 Disclaimers

Limited warranty and liability — Information in this document is believed to be accurate and reliable. However, NXP Semiconductors does not give any representations or warranties, expressed or implied, as to the accuracy or completeness of such information and shall have no liability for the consequences of use of such information. NXP Semiconductors takes no responsibility for the content in this document if provided by an information source outside of NXP Semiconductors. In no event shall NXP Semiconductors be liable for any indirect, incidental, punitive, special or consequential damages (including - without limitation - lost profits, lost savings, business interruption, costs related to the removal or replacement of any products or rework charges) whether or not such damages are based on tort (including negligence), warranty, breach of contract or any other legal theory. Notwithstanding any damages that customer might incur for any reason whatsoever, NXP Semiconductors' aggregate and cumulative liability towards customer for the products described herein shall be limited in accordance with the Terms and conditions of commercial sale of NXP Semiconductors.

Right to make changes — NXP Semiconductors reserves the right to make changes to information published in this document, including without limitation specifications and product descriptions, at any time and without

notice. This document supersedes and replaces all information supplied prior to the publication hereof.

Suitability for use — NXP Semiconductors products are not designed, authorized or warranted to be suitable for use in life support, life-critical or safety-critical systems or equipment, nor in applications where failure or malfunction of an NXP Semiconductors product can reasonably be expected to result in personal injury, death or severe property or environmental damage. NXP Semiconductors and its suppliers accept no liability for inclusion and/or use of NXP Semiconductors products in such equipment or applications and therefore such inclusion and/or use is at the customer's own risk.

Applications — Applications that are described herein for any of these products are for illustrative purposes only. NXP Semiconductors makes no representation or warranty that such applications will be suitable for the specified use without further testing or modification. Customers are responsible for the design and operation of their applications and products using NXP Semiconductors products, and NXP Semiconductors accepts no liability for any assistance with applications or customer product design. It is customer's sole responsibility to determine whether the NXP Semiconductors product is suitable and fit for the customer's applications and products planned, as well as for the planned application and use of customer's third party customer(s). Customers should provide appropriate design and operating safeguards to minimize the risks associated with their applications and products. NXP Semiconductors does not accept any liability related to any default, damage, costs or problem which is based on any weakness or default in the customer's applications or products, or the application or use by customer's third party customer(s). Customer is responsible for doing all necessary testing for the customer's applications and products using NXP Semiconductors products in order to avoid a default of the applications and the products or of the application or use by customer's third party customer(s). NXP does not accept any liability in this respect.

Limiting values — Stress above one or more limiting values (as defined in the Absolute Maximum Ratings System of IEC 60134) will cause permanent damage to the device. Limiting values are stress ratings only and (proper) operation of the device at these or any other conditions above those given in the Recommended operating conditions section (if present) or the Characteristics sections of this document is not warranted. Constant or repeated exposure to limiting values will permanently and irreversibly affect the quality and reliability of the device.

Terms and conditions of commercial sale — NXP Semiconductors products are sold subject to the general terms and conditions of commercial sale, as published at <http://www.nxp.com/profile/terms>, unless otherwise agreed in a valid written individual agreement. In case an individual agreement is concluded only the terms and conditions of the respective agreement shall apply. NXP Semiconductors hereby expressly objects to applying the customer's general terms and conditions with regard to the purchase of NXP Semiconductors products by customer.

No offer to sell or license — Nothing in this document may be interpreted or construed as an offer to sell products that is open for acceptance or the grant, conveyance or implication of any license under any copyrights, patents or other industrial or intellectual property rights.

Quick reference data — The Quick reference data is an extract of the product data given in the Limiting values and Characteristics sections of this document, and as such is not complete, exhaustive or legally binding.

Export control — This document as well as the item(s) described herein may be subject to export control regulations. Export might require a prior authorization from competent authorities.

Non-automotive qualified products — Unless this data sheet expressly states that this specific NXP Semiconductors product is automotive qualified, the product is not suitable for automotive use. It is neither qualified nor tested in accordance with automotive testing or application requirements. NXP Semiconductors accepts no liability for inclusion and/or use of non-automotive qualified products in automotive equipment or applications. In the event that customer uses the product for design-in and use in automotive applications to automotive specifications and standards, customer (a) shall use the product without NXP Semiconductors' warranty of the product for such automotive applications, use and specifications, and (b) whenever customer uses the product for automotive applications beyond NXP Semiconductors' specifications such use shall be solely at customer's own risk, and (c) customer fully indemnifies NXP Semiconductors for any liability, damages or failed product claims resulting from customer design and use of the product for automotive applications beyond NXP Semiconductors' standard warranty and NXP Semiconductors' product specifications.

Translations — A non-English (translated) version of a document is for reference only. The English version shall prevail in case of any discrepancy between the translated and English versions.

Security — Customer understands that all NXP products may be subject to unidentified or documented vulnerabilities. Customer is responsible for the design and operation of its applications and products throughout their lifecycles to reduce the effect of these vulnerabilities on customer's applications and products. Customer's responsibility also extends to other open and/or proprietary technologies supported by NXP products for use in customer's applications. NXP accepts no liability for any vulnerability. Customer should regularly check security updates from NXP and follow up appropriately. Customer shall select products with security features that best meet rules, regulations, and standards of the intended application and make the ultimate design decisions regarding its products and is solely responsible for compliance with all legal, regulatory, and security related requirements concerning its products, regardless of any information or support that may be provided by NXP. NXP has a Product Security Incident Response Team (PSIRT) (reachable at PSIRT@nxp.com) that manages the investigation, reporting, and solution release to security vulnerabilities of NXP products.

16.4 Trademarks

Notice: All referenced brands, product names, service names and trademarks are the property of their respective owners.

GreenChip — is a trademark of NXP B.V.

NXP — wordmark and logo are trademarks of NXP B.V.

Contents

1	General description	1
2	Features and benefits	1
2.1	Efficiency features	1
2.2	Application features	1
2.3	Control features	1
3	Applications	2
4	Ordering information	2
5	Marking	2
6	Block diagram	3
7	Pinning information	3
7.1	Pinning	3
7.2	Pin description	4
8	Functional description	5
8.1	Introduction	5
8.2	Operation	5
8.3	Protections	7
8.3.1	Gate pull-down	7
8.3.2	Power MOSFET drain-source protection	7
8.3.3	Minimum mains voltage	7
9	Limiting values	8
10	Thermal characteristics	9
11	Characteristics	10
12	Application information	12
13	Package outline	13
14	Abbreviations	14
15	Revision history	15
16	Legal information	16

Please be aware that important notices concerning this document and the product(s) described herein, have been included in section 'Legal information'.

© NXP B.V. 2021.

All rights reserved.

For more information, please visit: <http://www.nxp.com>

For sales office addresses, please send an email to: salesaddresses@nxp.com

Date of release: 14 April 2021
Document identifier: TEA2208T