

---

---

**ADVANTEST**<sup>®</sup>  
ADVANTEST CORPORATION

---

---

***R6561***

***Digital Multimeter***

***Operation Manual***

**MANUAL NUMBER FOE-8324330B01**

---

This product has been discontinued.  
The Operation Manual is provided by  
ADC Corporation under the agreement  
with Advantest Corporation.



---

## Safety Summary

To ensure thorough understanding of all functions and to ensure efficient use of this instrument, please read the manual carefully before using. Note that Advantest bears absolutely no responsibility for the result of operations caused due to incorrect or inappropriate use of this instrument.

If the equipment is used in a manner not specified by Advantest, the protection provided by the equipment may be impaired.

- **Warning Labels**

Warning labels are applied to Advantest products in locations where specific dangers exist. Pay careful attention to these labels during handling. Do not remove or tear these labels. If you have any questions regarding warning labels, please ask your nearest Advantest dealer. Our address and phone number are listed at the end of this manual.

Symbols of those warning labels are shown below together with their meaning.

**DANGER:** Indicates an imminently hazardous situation which will result in death or serious personal injury.

**WARNING:** Indicates a potentially hazardous situation which will result in death or serious personal injury.

**CAUTION:** Indicates a potentially hazardous situation which will result in personal injury or a damage to property including the product.

- **Basic Precautions**

Please observe the following precautions to prevent fire, burn, electric shock, and personal injury.

- Use a power cable rated for the voltage in question. Be sure however to use a power cable conforming to safety standards of your nation when using a product overseas.
- When inserting the plug into the electrical outlet, first turn the power switch OFF and then insert the plug as far as it will go.
- When removing the plug from the electrical outlet, first turn the power switch OFF and then pull it out by gripping the plug. Do not pull on the power cable itself. Make sure your hands are dry at this time.
- Before turning on the power, be sure to check that the supply voltage matches the voltage requirements of the instrument.
- Connect the power cable to a power outlet that is connected to a protected ground terminal. Grounding will be defeated if you use an extension cord which does not include a protected ground terminal.
- Be sure to use fuses rated for the voltage in question.
- Do not use this instrument with the case open.
- Do not place anything on the product and do not apply excessive pressure to the product. Also, do not place flower pots or other containers containing liquid such as chemicals near this

product.

- When the product has ventilation outlets, do not stick or drop metal or easily flammable objects into the ventilation outlets.
- When using the product on a cart, fix it with belts to avoid its drop.
- When connecting the product to peripheral equipment, turn the power off.

- **Caution Symbols Used Within this Manual**

Symbols indicating items requiring caution which are used in this manual are shown below together with their meaning.

**DANGER:** Indicates an item where there is a danger of serious personal injury (death or serious injury).

**WARNING:** Indicates an item relating to personal safety or health.

**CAUTION:** Indicates an item relating to possible damage to the product or instrument or relating to a restriction on operation.

- **Safety Marks on the Product**

The following safety marks can be found on Advantest products.



: ATTENTION - Refer to manual.



: Protective ground (earth) terminal.



: DANGER - High voltage.



: CAUTION - Risk of electric shock.

- **Replacing Parts with Limited Life**

The following parts used in the instrument are main parts with limited life.

Replace the parts listed below before their expected lifespan has expired to maintain the performance and function of the instrument.

Note that the estimated lifespan for the parts listed below may be shortened by factors such as the environment where the instrument is stored or used, and how often the instrument is used.

The parts inside are not user-replaceable. For a part replacement, please contact the Advantest sales office for servicing.

Each product may use parts with limited life.

For more information, refer to the section in this document where the parts with limited life are described.



## Main Parts with Limited Life

Part name	Life
Unit power supply	5 years
Fan motor	5 years
Electrolytic capacitor	5 years
LCD display	6 years
LCD backlight	2.5 years
Floppy disk drive	5 years
Memory backup battery	5 years

- **Hard Disk Mounted Products**

The operational warnings are listed below.

- Do not move, shock and vibrate the product while the power is turned on.  
Reading or writing data in the hard disk unit is performed with the memory disk turning at a high speed. It is a very delicate process.
- Store and operate the products under the following environmental conditions.  
An area with no sudden temperature changes.  
An area away from shock or vibrations.  
An area free from moisture, dirt, or dust.  
An area away from magnets or an instrument which generates a magnetic field.
- Make back-ups of important data.  
The data stored in the disk may become damaged if the product is mishandled. The hard disc has a limited life span which depends on the operational conditions. Note that there is no guarantee for any loss of data.

- **Precautions when Disposing of this Instrument**

When disposing of harmful substances, be sure dispose of them properly with abiding by the state-provided law.

Harmful substances: (1) PCB (polycarbon biphenyl)  
(2) Mercury  
(3) Ni-Cd (nickel cadmium)  
(4) Other  
Items possessing cyan, organic phosphorous and hexadic chromium and items which may leak cadmium or arsenic (excluding lead in solder).

Example: fluorescent tubes, batteries

---

# Environmental Conditions

This instrument should be only be used in an area which satisfies the following conditions:

- An area free from corrosive gas
- An area away from direct sunlight
- A dust-free area
- An area free from vibrations
- Altitude of up to 2000 m

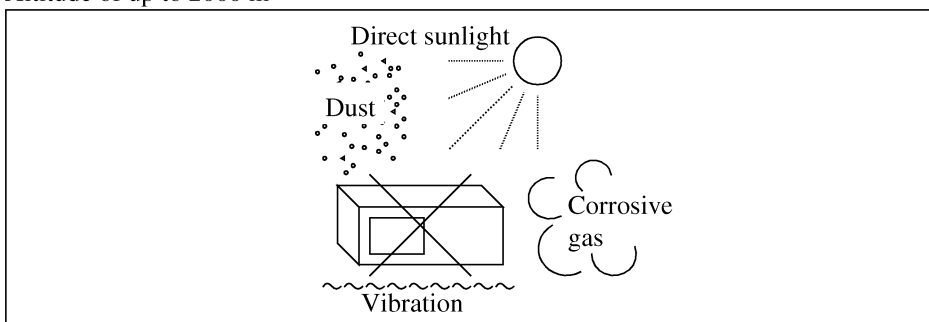

**Figure-1 Environmental Conditions**

- Operating position

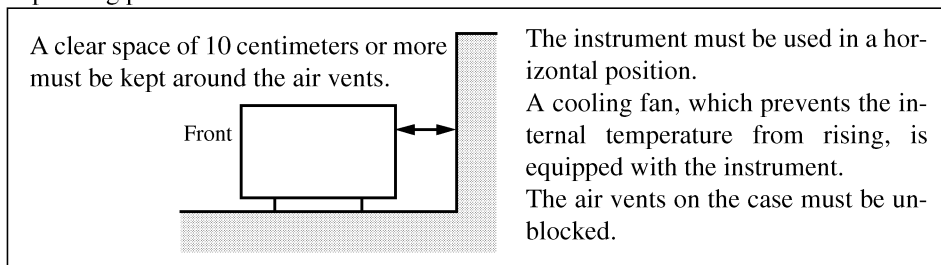

**Figure-2 Operating Position**

- Storage position

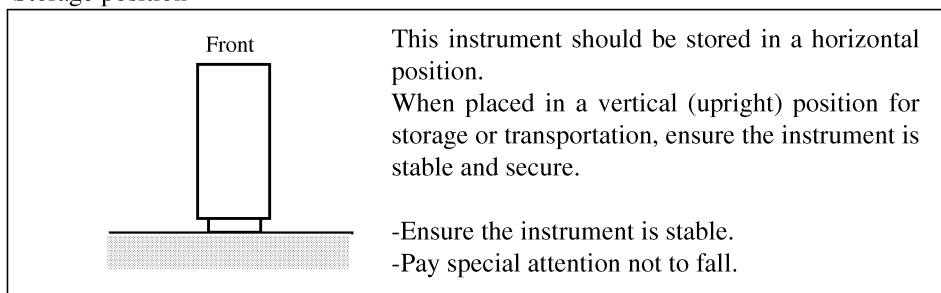

**Figure-3 Storage Position**



- The classification of the transient over-voltage, which exists typically in the main power supply, and the pollution degree is defined by IEC61010-1 and described below.

Impulse withstand voltage (over-voltage) category II defined by IEC60364-4-443

Pollution Degree 2

## Types of Power Cable

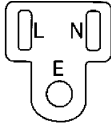
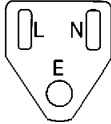
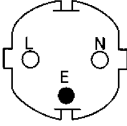
Replace any references to the power cable type, according to the following table, with the appropriate power cable type for your country.

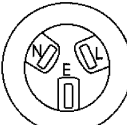
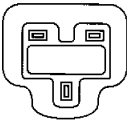
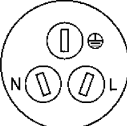
Plug configuration	Standards	Rating, color and length	Model number (Option number)
	PSE: Japan  Electrical Appliance and Material Safety Law	125 V at 7 A Black 2 m (6 ft)	Straight: A01402 Angled: A01412
	UL: United States of America  CSA: Canada	125 V at 7 A Black 2 m (6 ft)	Straight: A01403 (Option 95) Angled: A01413
	CEE: Europe DEMKO: Denmark NEMKO: Norway VDE: Germany KEMA: The Netherlands CEBEC: Belgium OVE: Austria FIMKO: Finland SEMKO: Sweden	250 V at 6 A Gray 2 m (6 ft)	Straight: A01404 (Option 96) Angled: A01414
	SEV: Switzerland	250 V at 6 A Gray 2 m (6 ft)	Straight: A01405 (Option 97) Angled: A01415
	SAA: Australia, New Zealand	250 V at 6 A Gray 2 m (6 ft)	Straight: A01406 (Option 98) Angled: -----
	BS: United Kingdom	250 V at 6 A Black 2 m (6 ft)	Straight: A01407 (Option 99) Angled: A01417
	CCC: China	250 V at 10 A Black 2 m (6 ft)	Straight: A114009 (Option 94) Angled: A114109



## Table of Power Cable Options

There are six power cable options (refer to following table).

Order power cable options by Model number.

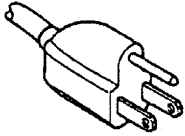
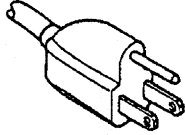
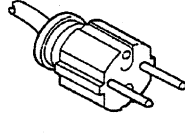
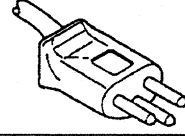
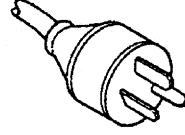
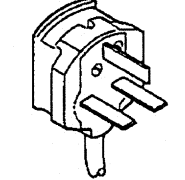
	Plug configuration	Standards	Rating, color, and length	Model number (Option number)
1		JIS: Japan Law on Electrical Appliances	125 V at 7 A Black 2 m (6 ft)	Straight: A01402 Angled: A01412
2		UL: United States of America CSA: Canada	125 V at 7 A Black 2 m (6 ft)	Straight: A01403 (Option 95) Angled: A01413
3		CEE: Europe DEMKO: Denmark NEMKO: Norway VDE: Germany KEMA: The Netherlands CEBEC: Belgium OVE: Austria FIMKO: Finland SEMKO: Sweden	250 V at 6 A Gray 2 m (6 ft)	Straight: A01404 (Option 96) Angled: A01414
4		SEV: Switzerland	250 V at 6 A Gray 2 m (6 ft)	Straight: A01405 (Option 97) Angled: A01415
5		SAA: Australia, New Zealand	250 V at 6 A Gray 2 m (6 ft)	Straight: A01406 (Option 98) Angled: -----
6		BS: United Kingdom	250 V at 6 A Black 2 m (6 ft)	Straight: A01407 (Option 99) Angled: A01417



R6561  
DIGITAL MULTIMETER  
OPERATION MANUAL

Table of Contents

TABLE OF CONTENTS

1. BEFORE USING THIS EQUIPMENT .....	1 - 1
1.1 Use of this Operation Manual .....	1 - 1
1.2 Outline of R6561 .....	1 - 2
1.3 Before Using .....	1 - 4
1.3.1 Check for Appearance and Accessories .....	1 - 4
1.3.2 Ambient Operating Conditions .....	1 - 4
1.3.3 Power Supply and Fuse .....	1 - 5
2. DESCRIPTION OF PANEL SURFACE AND OPERATING METHOD-1 (SETTING OF EACH PARAMETER) .....	2 - 1
2.1 Description of Panel Surface .....	2 - 1
2.1.1 Supplementary Description of Panel Face .....	2 - 3
2.2 POWER ON/OFF .....	2 - 6
2.2.1 POWER ON .....	2 - 6
2.2.2 POWER OFF .....	2 - 10
2.3 General Measurement Flowchart .....	2 - 11
2.4 FUNCTION .....	2 - 12
2.5 RANGE .....	2 - 14
2.6 SAMPLING .....	2 - 17
2.7 Description and Setting Method of Parameters .....	2 - 19
2.7.1 INT TIME: Integrate Time .....	2 - 22
2.7.2 AUTO ZERO: Auto Zero Calibration .....	2 - 24
2.7.3 AUTO CAL: Auto Calibration Interval .....	2 - 25
2.7.4 BUZZER: Buzzer Mode .....	2 - 27
2.7.5 D/A: D/A Output Mode .....	2 - 28
2.7.6 C FUNCTION: Computing Function .....	2 - 34
2.7.7 RES: Resolution .....	2 - 37
2.7.8 N .....	2 - 41
2.7.9 X/Y/Z .....	2 - 43
2.7.10 LOW .....	2 - 46
2.7.11 HIGH .....	2 - 49
2.7.12 LIMIT .....	2 - 53
2.7.13 GPIB: GPIB Address Switch .....	2 - 56
2.7.14 LINE: Line Frequency .....	2 - 61
2.7.15 SMOOTH: Smoothing .....	2 - 62
2.7.16 SM TIME: Smoothing Time .....	2 - 64
2.7.17 NULL .....	2 - 66
2.7.18 TEST .....	2 - 67
2.8 Basic Operating Method .....	2 - 70
2.8.1 Basic Operation .....	2 - 70
2.8.2 DC Voltage Measurement .....	2 - 71
2.8.3 Low Voltage DC Measurement .....	2 - 72
2.8.4 Resistance Measurement .....	2 - 75
3. OPERATING METHOD - 2 (COMPUTING FUNCTION) .....	3 - 1
3.1 General Description .....	3 - 1
3.2 Setting of Constants and Display of Computing Results .....	3 - 2
3.3 SCALING .....	3 - 3

R6561  
DIGITAL MULTIMETER  
OPERATION MANUAL

Table of Contents

---

3.4	%DEVIATION .....	3 - 5
3.5	DELTA .....	3 - 7
3.6	MULTIPLY .....	3 - 9
3.7	dB (Decibel Conversion) .....	3 - 10
3.8	RMS Value (Effective Value) .....	3 - 11
3.9	dBm (dBm Conversion) .....	3 - 13
3.10	Resistance Value Temperature Correction (at 20°C) .....	3 - 14
3.11	COMPARATOR 1 .....	3 - 16
3.12	COMPARATOR 2 .....	3 - 18
3.13	STATISTICS (Statistical Processing) .....	3 - 20
4.	GPIB INTERFACE .....	4 - 1
4.1	Outline .....	4 - 1
4.2	Outline of GPIB .....	4 - 2
4.3	Standards .....	4 - 4
4.4	GPIB Handling Method .....	4 - 7
4.4.1	Connection to Component Devices .....	4 - 7
4.4.2	Preparations for Operation .....	4 - 8
4.4.3	General Notes on Operation .....	4 - 10
4.5	Talker Format .....	4 - 12
4.5.1	General Format .....	4 - 12
4.5.2	Output Format in Execution of STATISTICS Computation .....	4 - 17
4.6	Listener Format .....	4 - 19
4.7	Service Request ("SRQ") .....	4 - 28
4.7.1	Outline .....	4 - 28
4.7.2	Service Request and Status Byte .....	4 - 28
4.7.3	Causes for Service Request .....	4 - 29
4.8	Operation Flowchart .....	4 - 32
4.9	Operation Note .....	4 - 33
4.10	Program Example .....	4 - 36
5.	MAINTENANCE, CHECK, AND CALIBRATION .....	5 - 1
5.1	Before Requesting Repair .....	5 - 1
5.2	Error Message .....	5 - 2
5.3	Storage .....	5 - 5
5.4	Calibration .....	5 - 6
5.4.1	Preparations for Calibration .....	5 - 6
5.4.2	Common Operation Items and Notes .....	5 - 9
5.4.3	Calibration of DC Voltage Measurement .....	5 - 9
5.4.4	Calibration of Low Voltage DC Measurement .....	5 - 17
5.4.5	Calibration of Resistance Measurement .....	5 - 24
6.	SPECIFICATION .....	6 - 1
6.1	Measuring Function .....	6 - 1
6.2	Integrate Time .....	6 - 12
6.3	Null Function .....	6 - 12
6.4	Smoothing Function .....	6 - 12
6.5	Sampling Mode .....	6 - 12
6.6	Computing Function .....	6 - 13
6.6.1	Primary Computing Function .....	6 - 13
6.6.2	Secondary Computing Function .....	6 - 14



R6561  
DIGITAL MULTIMETER  
OPERATION MANUAL

Table of Contents

---

6.7 Input/Output Function .....	6 - 15
6.8 General Specifications .....	6 - 16
7. FUNCTIONAL DESCRIPTION .....	7 - 1
7.1 Outline .....	7 - 1
7.2 Functional Description .....	7 - 3
APPENDIX .....	A - 1
A.1 Terminologies .....	A - 1
LIST OF FIGURES .....	F - 1
LIST OF TABLES .....	T - 1



R6561  
DIGITAL MULTIMETER  
OPERATION MANUAL

1.1 Use of this Operation Manual

1. BEFORE USING THIS EQUIPMENT

1.1 Use of this Operation Manual

This manual describes how to use this digital multimeter in the order as shown in Figure 1-1 for users who have some knowledge and experience of such equipment.

Those who are using this type of multimeter for the first time are advised to read this manual thoroughly from the beginning.

Users who are familiar with a digital voltmeter, etc., can understand the operation of this equipment merely by referencing the description of the panel in [Chapter 2. OPERATING METHOD] and the method of setting each parameter covered in [Section 2.3 General Measurement Flowchart].

Since use of the GPIB in Chapter 4 requires a basic knowledge of programming, refer to the fundamental guide for programming when necessary.

Introduction of R6561 (1.2)
Requirement before Use (1.3)
[Basic Operation] Description of Panel Surface (2.1) Preparations for Measurement (2.2 to 2.6) Setting of Measurement Parameters (2.7)
Computing Function (3.)
GPIB (4.)
MAINTENANCE, INSPECTION, AND CALIBRATION (5.)
PERFORMANCE TECHNICAL DATA (6.) FUNCTIONAL DESCRIPTION (7.)
Definition of Terminology

Figure 1 - 1 Composition of this Manual

R6561  
DIGITAL MULTIMETER  
OPERATION MANUAL

1.2 Outline of R6561

---

1.2 Outline of R6561

The R6561 is a high performance digital multimeter with the maximum display capacity of 6.5 digits of "1199999". It provides the functions of measuring DC voltage, low voltage DC, and resistance (HI Power/LO Power).

A highly sensitive semiconductor chopper system with a maximum resolution of 10nV has been adopted in the measurement of low voltage DC. As a result, this digital multimeter is quite invulnerable to changes after lapse of time and therefore can perform stable measurements for long period of time.

The R6561 can make high-precision measurements of resistance, not affected by line resistance, since its maximum resolution is  $1.0\mu\Omega$  and constant current source is floating. Since the voltage between open pins is kept below  $20\text{mV}_{\text{peak}}$  (when set to the LO P mode), this digital meter can measure contact resistance, etc. of electronic parts without destroying their oxide film. The power consumption in a measured device is as small as 1.0nW min. and  $10\mu\text{W}$  max.

In addition to such measuring functions, the R6561 provides a NULL function which can make offset correction, a digital smoothing function, and an abundance of operating functions for the processing of measurement data. Also, it can select and set an integrate time to meet a required measuring accuracy.

Further, this equipment is provided with a full-remote control function by the GPIB, analog output, trigger input, and measurement end signal output as its standard configuration.

Features of this equipment are as follows:

- High resolution of 1.0ppm in display of DC voltage of 6-1/2 digit (maximum display: 1199999)
- Highly sensitive measurement of low voltage DC with a resolution of 10nV owing to the adoption of a semiconductor chopper system
- One-touch zero adjustment available for low voltage DC using the ZERO ADJ key.
- Measurement of resistance with a resolution of  $1.0\mu\Omega$
- Equipped with a voltage limiter between open pins less than  $20\text{mV}_{\text{peak}}$  (when set to the LO P mode)
- Measurement of resistance with a low power consumption (maximum power consumption:  $10\mu\text{W}$  when set to the LO P mode)
- Possible to select a measurement current in the HI P/LO P mode in the measurement of resistance

R6561  
DIGITAL MULTIMETER  
OPERATION MANUAL

1.2 Outline of R6561

---

- Measurement of resistance not affected by thermoelectromotive force owing to the adoption of automatic offset canceling system
- Measurement of resistance not affected by the resistance value of measuring cable, and yet floating current source provided which enables a high-speed measurement
- Stabilized measurement with an integral type AD converter capable of selecting an integrate time
- NULL function to correct offset through one-touch operation
- Digital smoothing function
- Soft calibration which is easy for calibration
- Equipped with panel compatible GPIB interface, trigger input, and measurement end signal output as its standard configuration
- Provided with D/A converter output to enable monitoring with the analog signal as the standard configuration
- Wide variety of computing functions, such as dB, dBm, rms, statistical processing, and cable resistance value temperature correction (20°C), etc.
- Display of output data, unit, and function using highly visible green LEDs

R6561  
DIGITAL MULTIMETER  
OPERATION MANUAL

1.3 Before Using

1.3 Before Using

1.3.1 Check for Appearance and Accessories

When this equipment is delivered, check if any damage has occurred during transportation. Next, check the quantity and standards of standard accessories referring to Table 1-1.

If any part is found to be damaged, or if any accessory is missing, contact the nearest dealer or the sales and support office. Address and telephone Nos. are given at the end of this manual.

Request to User : When ordering add-on accessories and the like, be good enough to stipulate the model (or stock No.) concerned.

Table 1 - 1 Standard Accessories of R6561

Product name	Model	Stock No.	Q'ty	Remarks
Power cable	A01402	DCB-DD2428x01	1	
Input cable	MI-37	DCB-MM0412	1	For measurement of DC voltage
	A01020	AAA-A01020	1	For measurement of low voltage DC
	A01004	AAA-A01004	1	For measurement of resistance
Slow-blow fuse	EAWK0.315A	DFT-AAR315A	2	When the supply voltage is 100/120V
	EAWK0.16A	DFT-AAR16A		When the supply voltage is 220/240V
Operation Manual	-	JR6561	1	Japanese edition
	-	ER6561		English edition

1.3.2 Ambient Operating Conditions

The ambient operating conditions must be 0°C to +40°C and less than 85% relative humidity.

Avoid using this equipment in a location which is subject to direct sunlight or where any corrosive gas is generated. Also, avoid vibration or mechanical shock.

R6561  
DIGITAL MULTIMETER  
OPERATION MANUAL

1.3 Before Using

1.3.3 Power Supply and Fuse

(1) Power Supply

The supply voltage is preset in the factory when this equipment is shipped. The corresponding values are clearly marked in a table under the power connector at the rear panel.

Check that the supply voltage in use coincides with the value marked in the table. When inserting or unplugging the power cable, be sure to check in advance that the POWER switch is OFF.

(2) Power Cable

When a measurement is made using a commercial power supply, be sure to ground the equipment to prevent electric shocks.

The plug for the power cable has three pins. The round pin in the center is the ground. When connecting to a socket using adapter A09034 attached to the plug, connect the GND pin on the rear panel of this equipment to the external ground.

The attached adapter A09034 conforms to the Electrical Appliance and Material Control Law, Japan.

Since the width of the two electrodes, A and B of the adapter A09034, are different as shown in Figure 1-2 (b), check the alignment when inserting the plug into the socket. When the A09034 cannot be connected to the socket, purchase adapter KPR-13.

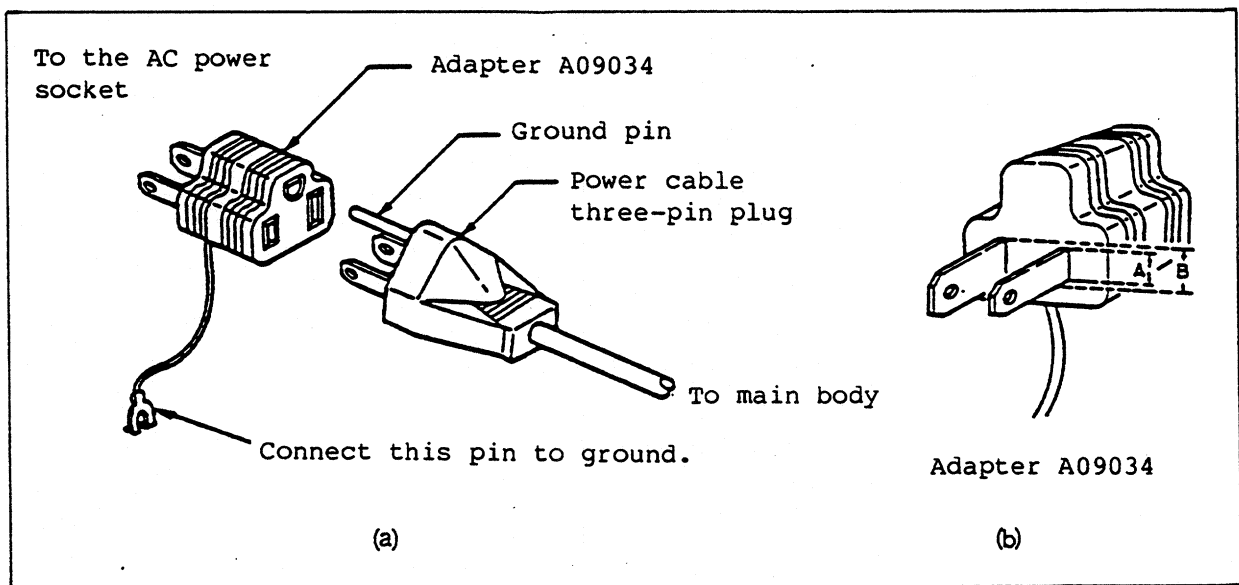

Figure 1 - 2 Plug and Adapter for Power Cable

R6561  
DIGITAL MULTIMETER  
OPERATION MANUAL

1.3 Before Using

(3) Frequency

Set the power frequency to 50Hz or 60Hz as required.

For the power frequency setting method, see [2.7.14, LINE: Line frequency].

(4) Checking and Replacement of Fuse

CAUTION

Be sure to unplug the power cable before replacing the fuse.

The power fuse is contained in the fuse holder on the rear panel. When the fuse is checked or replaced, unplug the power cable from the power connector and pull out the cap of the fuse holder to ward you. The fuse can then be removed from the holder. Since the fuse standards differ according to the supply voltage in use, be sure to replace the fuse with one which meets the supply voltage standards. [See Table 1-2].

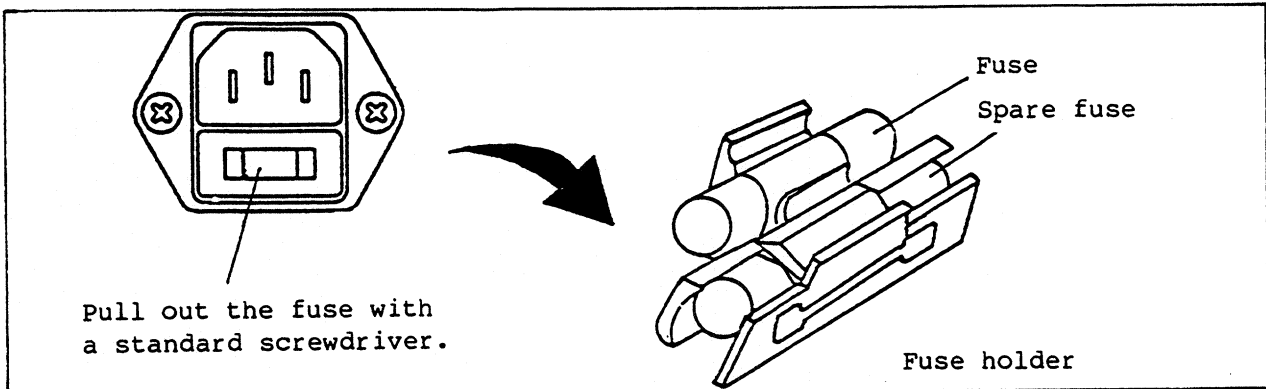

Figure 1 - 3 Fuse Holder

Table 1 - 2 Fuse Standards

Supply voltage	Fuse standards
90 to 110V	0.315A
103 to 132V	0.315A
198 to 242V	0.16A
207 to 250V	0.16A



R6561  
DIGITAL MULTIMETER  
OPERATION MANUAL

1.3 Before Using

---

(5) For Preheating Time

Although all functions operate simultaneously with the power ON, allow a preheating time of 60 minutes or more to obtain the specified accuracy.



R6561  
DIGITAL MULTIMETER  
OPERATION MANUAL

2.1 Description of Panel Surface

2. DESCRIPTION OF PANEL SURFACE AND OPERATING METHOD-1  
(SETTING OF EACH PARAMETER)

2.1 Description of Panel Surface

(1) Front Panel

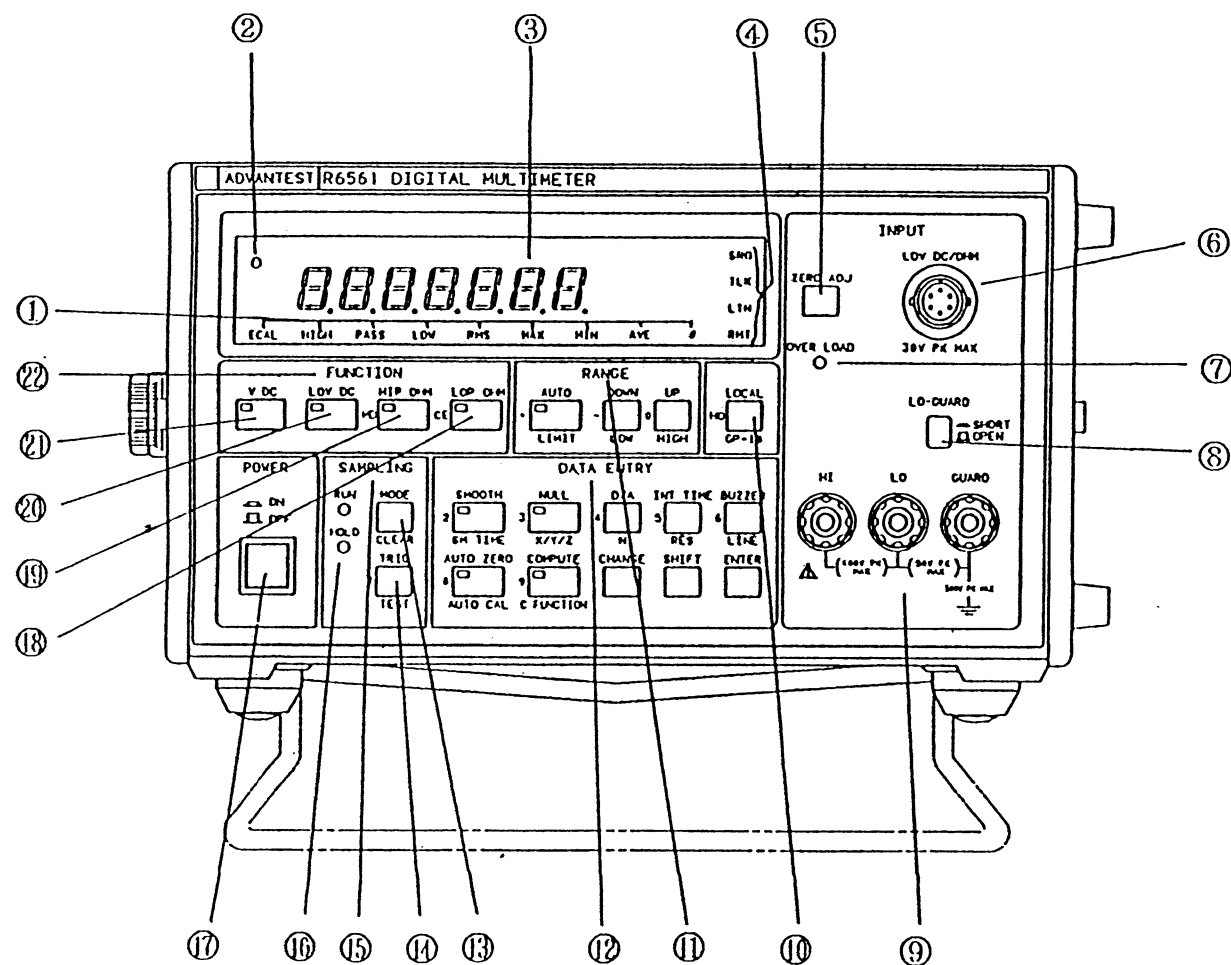

① Computing Function Lamps

These lamps are used to display computing functions and the computing function currently output in the display block.

② BUSY Lamp

This lamp indicates that the corresponding function is in operation. (See item (2) in 2.1.1.)

③ Display Block

This block displays the measurement data (unit and decimal points) and the set data for control parameters. (See item (1) in 2.1.1.)

④ GPIB Status Lamp

When this equipment is controlled by the GPIB, this lamp indicates the status of the GPIB.

⑤ ZERO ADJ Key

This key is used to make a zero adjustment when measuring low voltage DC and resistance. (See item (5) in 2.1.1.)

⑥ Low voltage DC and input terminal for resistance measurement (See item (8) in 2.1.1.)

⑦ Limiter Lamp for Voltage between Open Terminals

This lamp indicates that the voltage limiter between open terminals is in operation in the measurement of resistance. (See item (6) in 2.1.1.)

⑧ LO-GUARD SHORT Key

This key is used to select whether or not the LO terminal and GUARD terminal are shorted. (See item (7) in 2.1.1.)

⑨ Input terminal for DC voltage measurement (See item (8) in 2.1.1.)

⑩ LOCAL Key

This is used to clear the REMOTE mode. (See item (4) in 2.1.1.)

⑪ Key block to select measurement range in each measuring function (See Section 2.5.)

⑫ Key block to set parameters (See Section 2.7.)

⑬ Key to select the SAMPLING mode (See Section 2.6.)

⑭ Key to input TRIGGER signal (See Section 2.6.)

⑮ SAMPLING mode selection key block (See Section 2.6.)

⑯ SAMPLING mode indicator lamp (See Section 2.6.)

⑰ POWER switch

⑱ LO-P mode resistance measuring function selection key

⑲ HI-P mode resistance measuring function selection key

⑳ Low voltage DC measuring function selection key

㉑ DC voltage measuring function selection key

㉒ Function Key Block

This is a key block to select a measuring function. (See Section 2.4.)

R6561  
DIGITAL MULTIMETER  
OPERATION MANUAL

2.1 Description of Panel Surface

(2) Rear Panel

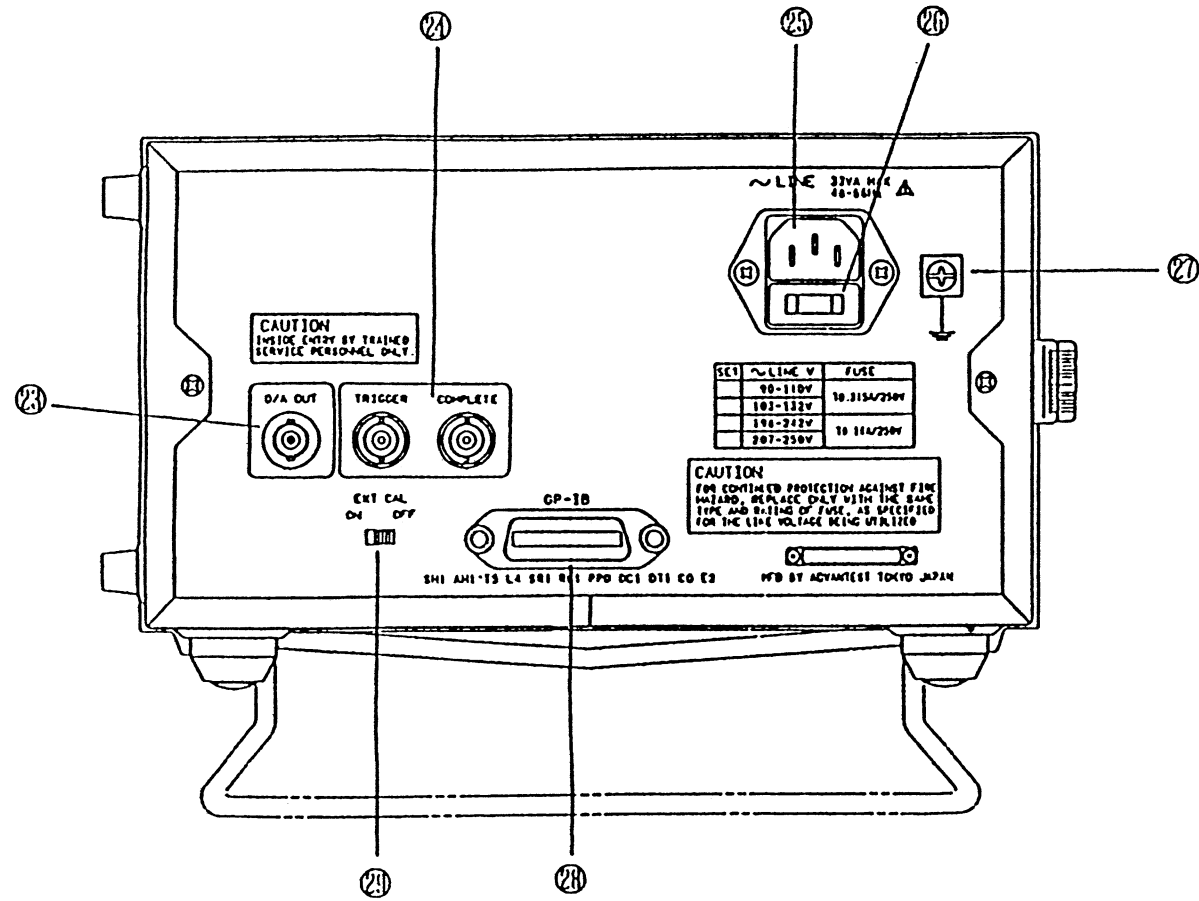

②③ Analog Signal Output Connector

This connector is used to output the result of a measurement with the analog signal.

②④ Connector for Control Signals

TRIGGER input terminal and COMPLETE output terminal (See item (12) in 2.1.1.)

②⑤ Power Connector

Connector for the connection of AC power supply (See item (9) in 2.1.1.)

②⑥ Fuse Holder (See item (4) in 1.3.3.)

②⑦ GND Connecting Terminal (See item (10) in 2.1.1.)

②⑧ GPIB Connector

This connector is used when this equipment is controlled externally using the GPIB.

②⑨ EXT CAL Switch

This switch is used when each measuring function is calibrated. (See item (11) in 2.1.1.)

R6561  
DIGITAL MULTIMETER  
OPERATION MANUAL

2.1 Description of Panel Surface

---

2.1.1 Supplementary Description of Panel Face

- Front Panel

(1) Display Block

Displays the measurement data (including a unit, decimal point, and "-" polarity) and the set data for control parameters.

This block contains 7-segment LEDs for the left side seven digits and 5 x 7 dot matrix type LEDs for the right side two digits, totaling nine digits. The maximum display is "1199999" (display of 6-1/2 digit).

In the display of 5-1/2 digit, the lowest order digit of the seven digits becomes a blank. In the same way, the low order two digits become blank in the display of 4-1/2 digit.

When overloaded, "OL" is displayed. (At this time, decimal points are also displayed through which the measuring range when overloaded can be easily determined.)

(2) BUSY Lamp

This lamp lights when its corresponding function is in operation.

(3) GPIB Status Lamp

When the unit is controlled by the GPIB, this lamp indicates the status of the GPIB.

The SRQ lamp lights when the unit is transmitting a service request to the controller.

The TLK lamp lights when the unit is in the talker status in which it transmits data.

The LTN lamp lights when the unit is in the listener status in which it receives data.

The RMT lamp lights when the unit is controlled externally.

When the RMT lamp is lighted, all panel keys except the LOCAL are disabled.

R6561  
DIGITAL MULTIMETER  
OPERATION MANUAL

2.1 Description of Panel Surface

---

(4) LOCAL Key

This is a switch used to release the external control when the R6561 is in the REMOTE mode (when the RMP lamp is lighted) in which it is controlled externally to enable control through the front panel. (However, the REMOTE mode cannot be released when the "LLO (Local Lockout)" command is set by the GPIB.)

(5) ZERO ADJ Key

This key is used to make a zero adjustment in the measurement of low voltage DC and resistance. When the ZERO ADJ key is pressed, the zero adjustment is made for the range set at that time.

(6) Limiter Lamp of Voltage between Open Terminals

This lamp lights when the voltage limiter between open terminals is in operation in the measurement of resistance. When the voltage between open terminals is about to exceed 1.0V in the HI-P mode and 20mV in the LO-P mode, the limiter operates and this lamp lights.

(7) LO-GUARD SHORT Key

This key is used to short between the LO terminal and the GUARD terminal of the input terminals. They are shorted when this key is pressed and opened when the same key is pressed again.

(8) Input Terminal

This equipment provides two input terminals. One is for measurement of DC voltage and the other for that of low voltage DC and resistance. Since the LO terminals of these two input terminals are shared, care should be taken that no voltage is applied between these LO terminals.

- Rear Panel

(9) Power Connector

This connector is used to connect the AC power supply to the unit with the power cable supplied together with this equipment.

(10) GND Pin

This is a grounding pin.

When the power cable plug is used with the two-pin adapter A09034, be sure to connect the lead from the adapter (see Figure 1-2) or this GND terminal to the ground.

R6561  
DIGITAL MULTIMETER  
OPERATION MANUAL

2.1 Description of Panel Surface

---

(11) EXT CAL Switch

This switch is used when each measuring function is calibrated. It is normally OFF. When set to ON, the E CAL lamp in the display block lights.

(12) Connector for Control Signal

The TRIGGER input terminal is the TRIGGER signal input terminal to trigger a measurement start. This input signal is the TTL level negative pulse (pulse width: 100 $\mu$ sec or more).

The COMPLETE output terminal is used to output the STROBE signal when measurement data or computed data is output. This output signal is the TTL level negative pulse (pulse width: approx. 130 $\mu$ sec).

R6561  
DIGITAL MULTIMETER  
OPERATION MANUAL

---

2.2 POWER ON/OFF

2.2 POWER ON/OFF

CAUTION

For Preheating Time

Although all functions are operated simultaneously with the power ON, allow a preheating time of 60 minutes or more to obtain the specified accuracy.

2.2.1 POWER ON

- (1) Press the POWER switch to turn the power ON

After displaying various modes of the self-test and R6561, the system enter the routine measuring mode.

The operation flow of the equipment after the power is ON is as shown below:

Note: For details of error messages, see Section 5.2.

If an error message is output at this stage, there must be a problem. Turn OFF the power in this status and contact the nearest dealer or the sales and support offices.



R6561  
 DIGITAL MULTIMETER  
 OPERATION MANUAL

2.2 POWER ON/OFF

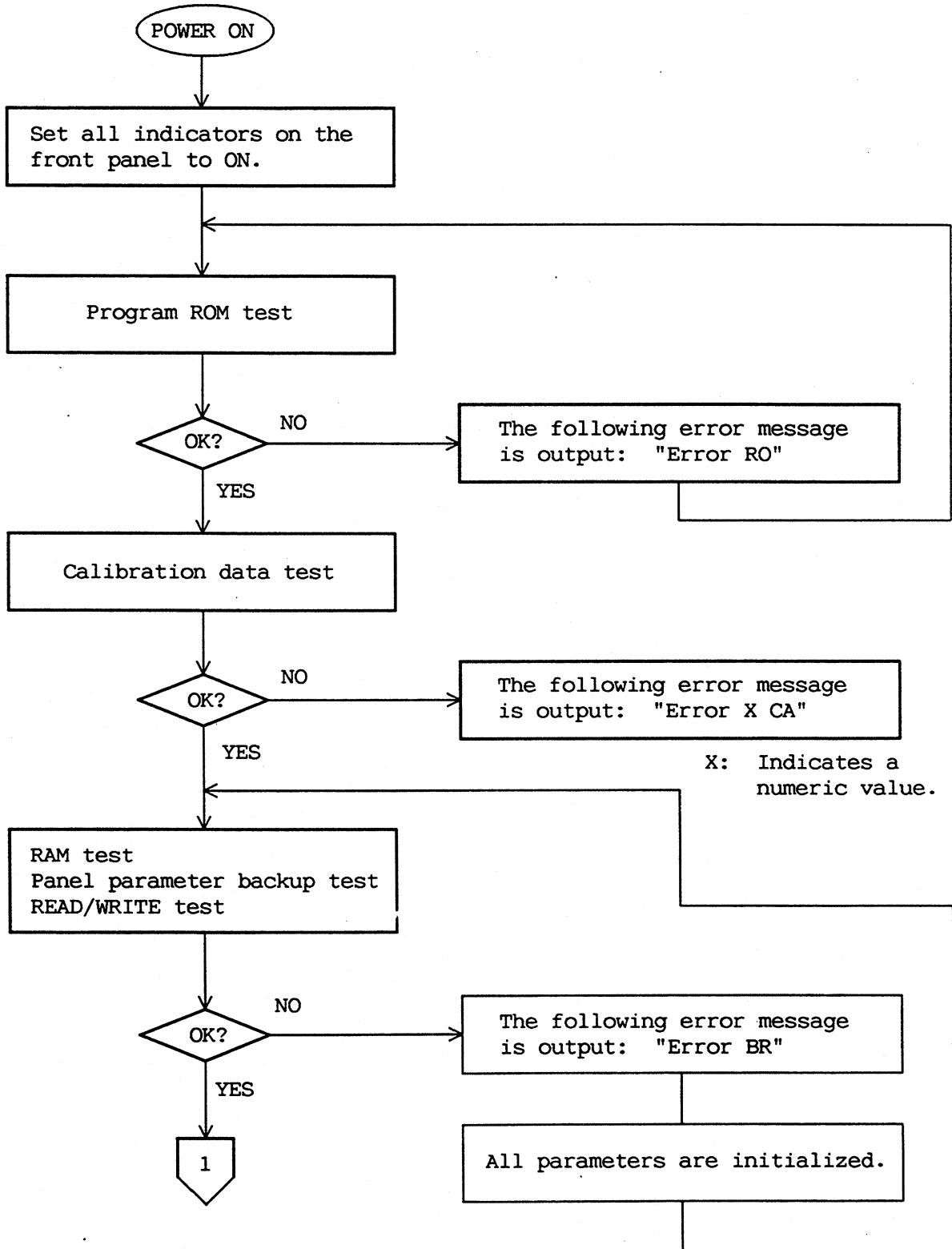

R6561  
DIGITAL MULTIMETER  
OPERATION MANUAL

2.2 POWER ON/OFF

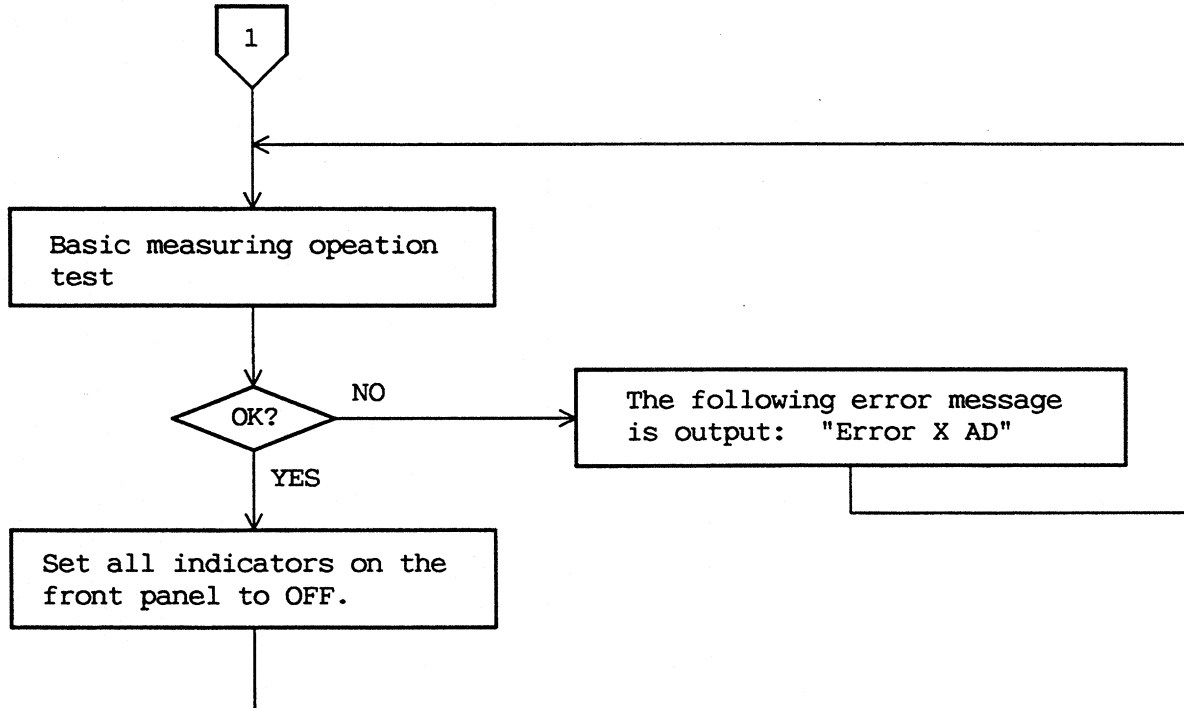

This ends the self test. The screen, then, displays various modes of the R6561.

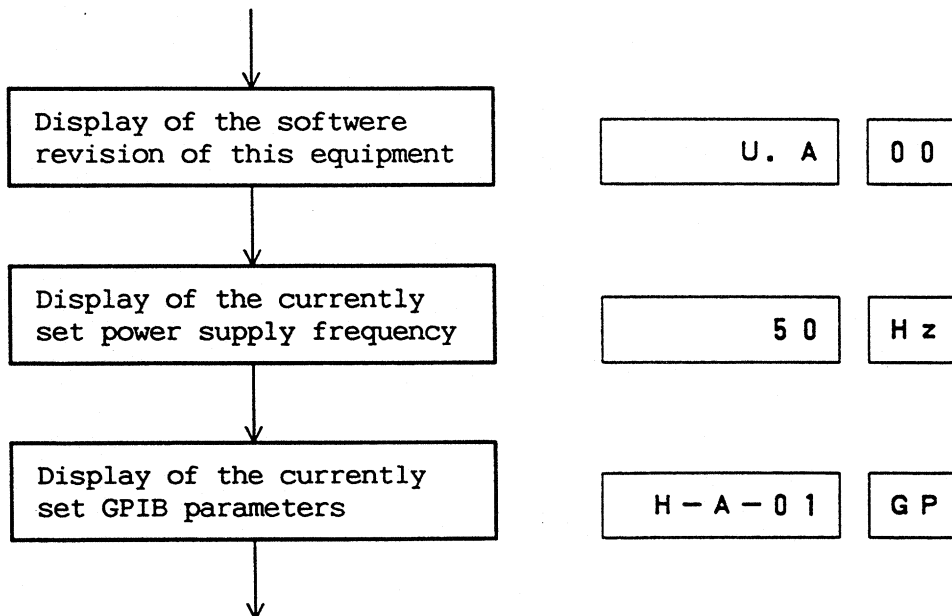

The system enters routine operation.

(2) When the system has entered routine operation, first set the power supply frequency (50Hz or 60Hz) according to the following method:

R6561  
DIGITAL MULTIMETER  
OPERATION MANUAL

2.2 POWER ON/OFF

[Setting Method]

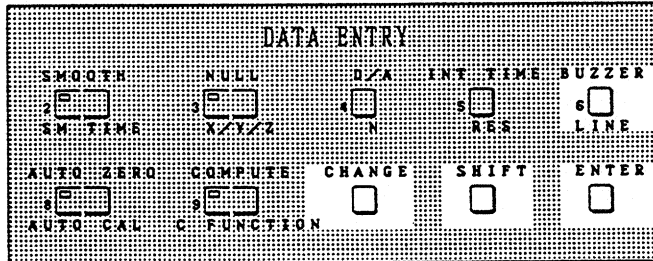

- LINE Parameter Setting

- ① Press the SHIFT key.

Each key then functions as a parameter printed on the lower side of the key.

- ② Press the LINE key.

The display block indicates the previous set value.

- Power Supply Frequency Selection

- ③ Press the CHANGE key.

The power supply frequency is then selected (50Hz or 60Hz).

Each time the CHANGE key is pressed, the display changes as shown below:

50Hz  $\rightleftharpoons$  60Hz

The power supply frequency to be set is displayed in the display block.

50 Hz

- End of Power Supply Frequency Setting

R6561  
DIGITAL MULTIMETER  
OPERATION MANUAL

2.2 POWER ON/OFF

---

- ④ Press the ENTER key.

The power supply frequency displayed in the display block is stored in the internal memory.

This completes the power supply frequency setting.

2.2.2 POWER OFF

When the POWER switch is pressed again in the power ON status, the power supply is turned OFF.

Since various parameters set are backed up by battery, they are not erased even if the power is turned OFF. (However, parameters COMPUTE, NULL and SMOOTH are initialized.)

R6561  
DIGITAL MULTIMETER  
OPERATION MANUAL

2.3 General Measurement Flowchart

2.3 General Measurement Flowchart

The following is a flowchart of the operating procedures from power ON to the start of measurement. For details see the corresponding item.

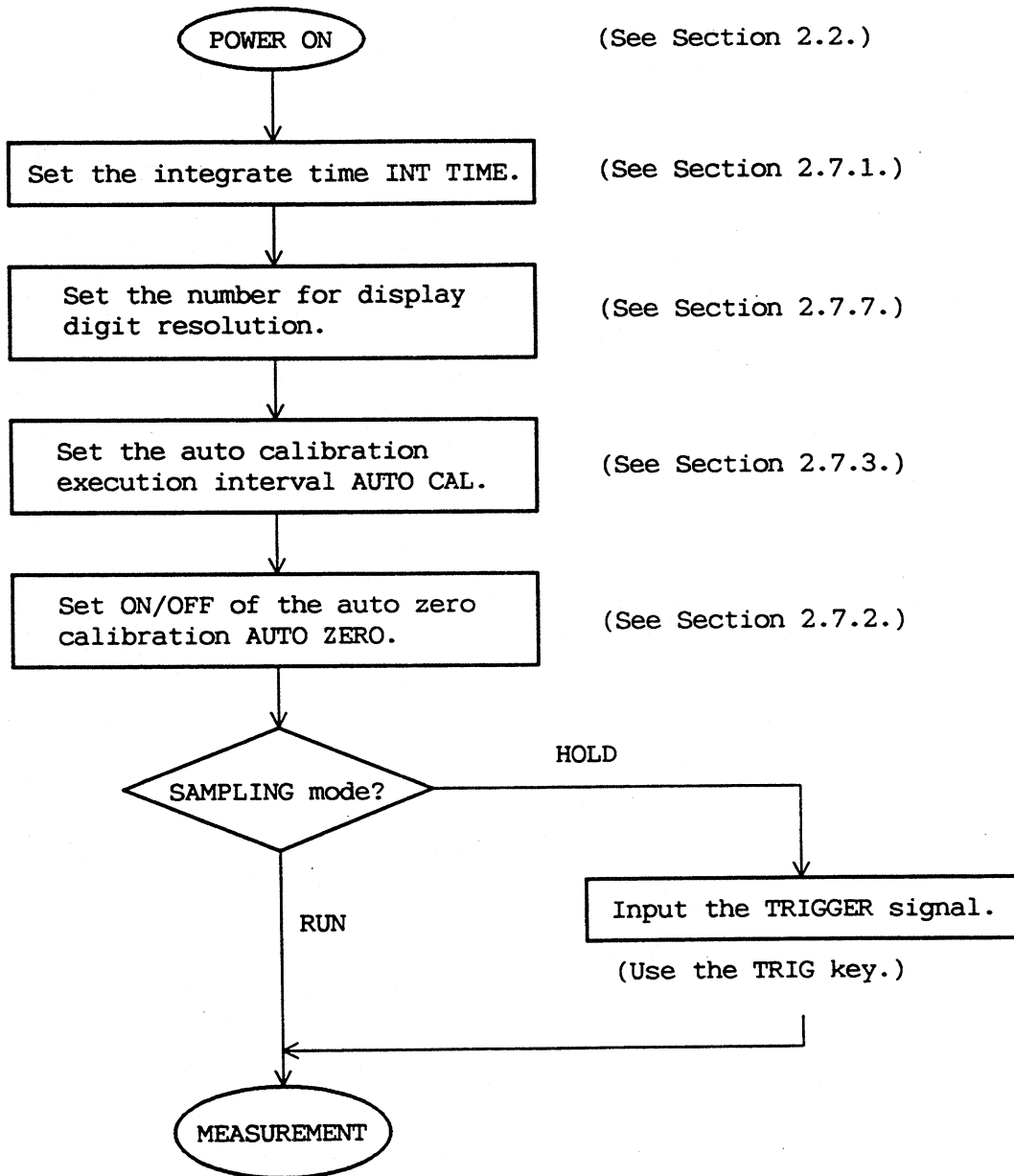

R6561  
DIGITAL MULTIMETER  
OPERATION MANUAL

2.4 FUNCTION

2.4 FUNCTION

[Functional Description]

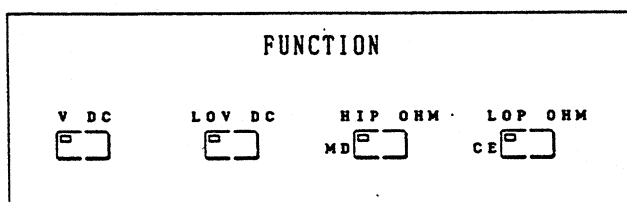

Keys on the FUNCTION block are used to select measuring functions. The following functions can be selected using function keys:

- ① DC voltage measuring function : V DC key
- ② Low voltage DC measuring function : LOV DC key
- ③ HI-P mode resistance measuring function: HIP OHM key
- ④ LO-P mode resistance measuring function: LOP OHM key

[Setting Method]

The following is a description of the method of setting measuring functions.

- Measuring Function Setting

Press and select the corresponding key of the function to be set. When the lamp of the set function lights, the setting is completed.

- ① When the DC Voltage Measuring Function is Set

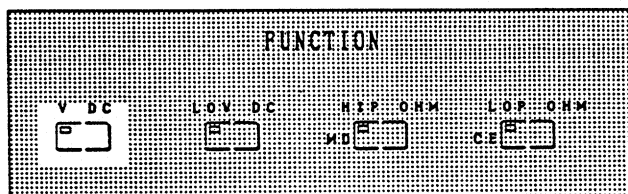

Press the V DC key.

The lamp in the key lights and the setting is completed.

R6561  
DIGITAL MULTIMETER  
OPERATION MANUAL

2.4 FUNCTION

- ② When the Low Voltage DC Measuring Function is Set

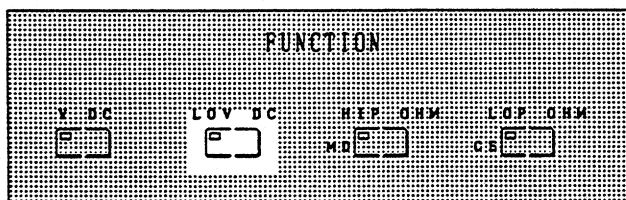

Press the LOV DC key.

The lamp in the key lights and the setting is completed.

- ③ When the HI-P Mode Resistance Measuring Function is Set

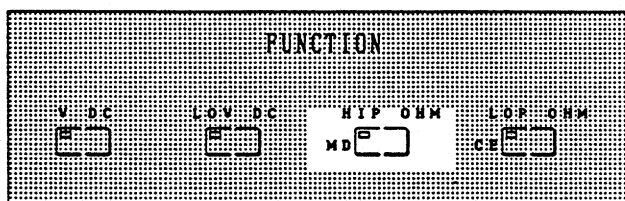

Press the HIP OHM key.

The lamp in the key lights and the setting is completed.

- ④ When the LO-P Mode Resistance Measuring Function is Set

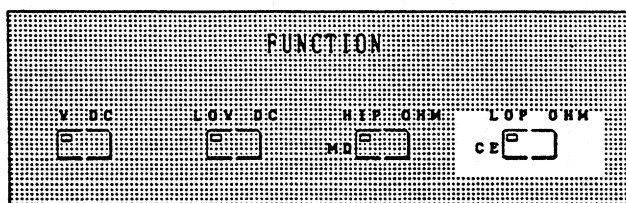

Press the LOP OHM key.

The lamp in the key lights and the setting is completed.

R6561  
DIGITAL MULTIMETER  
OPERATION MANUAL

2.5 RANGE

[Functional Description]

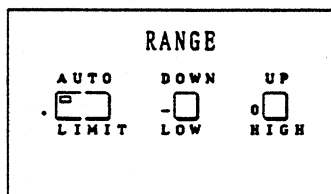

Keys in the RANGE block are used to select the measuring range.

The range selected can be distinguished from others according to its corresponding unit display and position of the decimal point. Table 2-1 shows the range configuration of the R6561.

Table 2 - 1 R6561 Measuring Range Configuration

VDC	LO VDC	HIP-Ω	LOP-Ω
—	1000μV		100mΩ
	10mV	1000mΩ	1000mΩ
	100mV (*)	10Ω	10Ω
1000mV	1000mV	100Ω (*)	100Ω (*)
10V (*)	10V	1000Ω	1000Ω
100V	—	10kΩ	—
500V		—	

\* Initial range



R6561  
DIGITAL MULTIMETER  
OPERATION MANUAL

2.5 RANGE

Table 2 - 2 Auto Range Level

Function	Range	Maximum number of display digits	FULL SCALE	UP level	DOWN level
VDC	1000mV	6-1/2 digit	1199999	1200000	-
	10V	6-1/2 digit	1199999	1200000	99999
	100V	6-1/2 digit	1199999	1200000	99999
	500V	6-1/2 digit	519999	520000	49999
LO VDC	1000μV	5-1/2 digit	119999	120000	-
	10mV	6-1/2 digit	1199999	1200000	99999
	100mV	6-1/2 digit	1199999	1200000	99999
	1000mV	6-1/2 digit	1199999	1200000	99999
	10V	6-1/2 digit	1199999	1200000	99999
HIP-OHM	1000mΩ	6-1/2 digit	119999	1200000	-
	10Ω	6-1/2 digit	1199999	1200000	99999
	100Ω	6-1/2 digit	1199999	1200000	99999
	1000Ω	6-1/2 digit	1199999	1200000	99999
	10kΩ	5-1/2 digit	119999	120000	9999
LOP-OHM	100mΩ	5-1/2 digit	119999	120000	-
	1000mΩ	5-1/2 digit	119999	120000	9999
	10Ω	5-1/2 digit	119999	120000	9999
	100Ω	5-1/2 digit	119999	120000	9999
	1000Ω	4-1/2 digit	11999	12000	999

Two modes, AUTO and MANUAL, are available for the selection of the measuring range. When AUTO is selected, the optimum range corresponding to the input signal is automatically selected from among ranges shown in the table above.

When MANUAL is selected, the optimum range is selected when the DOWN or UP key is pressed.

R6561  
DIGITAL MULTIMETER  
OPERATION MANUAL

2.5 RANGE

[Setting Method]

The following is a description of how to select a range.

- Range Selection

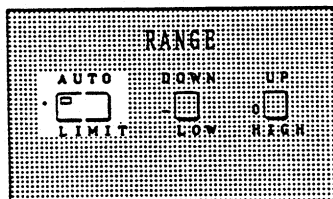

- ① Select AUTO/MANUAL using the AUTO key.

AUTO is selected when the lamp in the AUTO key is lighted, and MANUAL when the lamp in the AUTO key is extinguished.

Each time the AUTO key is pressed, AUTO/MANUAL is switched.

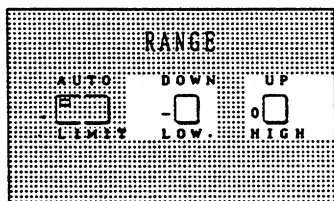

- ② Range Selecting Method in the MANUAL Mode

Press the UP key when the current measuring range is to be changed to the upper range, and the DOWN key when the range is to be changed to the lower range.

Each time either the UP or DOWN key is pressed once, the range is changed by one level.

- ③ If the UP or DOWN key is pressed when the AUTO range is selected, the range is automatically changed to MANUAL.

2.6 SAMPLING

[Functional Description]

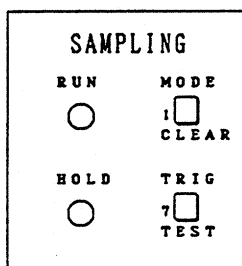

Keys in the SAMPLING block are used to select the SAMPLING mode (RUN or HOLD).

These also include a key to input the TRIGGER signal.

In each mode, the sampling is done as follows:

(1) RUN Mode

- ① The sampling is automatically repeated with a fixed period.
- ② Each time sampling is executed, the lamp (BUSY lamp) on the right upper part of the display block lights and the measured value at that time is displayed.

(2) HOLD Mode

- ① When the TRIGGER signal is input, the sampling is executed once only.
- ② When the sampling is executed, the lamp (BUSY lamp) in the left upper part of the display block lights once and the measured value at that time is displayed.
- ③ Subsequently, no sampling is executed until the TRIGGER signal is input.
- ④ The TRIGGER signal is input by the following means:
  - TRIG key in the SAMPLING block on the front panel
  - TRIGGER input terminal on the rear panel
  - GPIB "E" and GET commands

R6561  
DIGITAL MULTIMETER  
OPERATION MANUAL

2.6 SAMPLING

[Setting Method]

The following is a description of setting the SAMPLING mode.

- SAMPLING Mode Setting

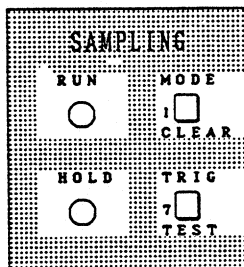

Select the SAMPLING mode (RUN or HOLD).

The selection is made using the MODE key.

Each time the MODE key is pressed, the lamp on the left side lights as shown below:

RUN  $\leftrightarrow$  HOLD

When the lamp of mode to be set lights, the setting is completed.

## 2.7 Description and Setting Method of Parameters

A parameter is a variable which has the role of setting various measuring conditions on the digital multimeter to make an accurate measurement.

This section describes keys required for the setting of parameters and initialization of parameters before entering the description of the setting of each parameter.

### (1) Parameter Setting Key

- ① HO  (HOME key)



This key cancels the parameter data being set (before pressing the ENTER key) in the parameter data set mode and returns to routine measurement with the previously set parameter intact.

- ② CE  (CE key)

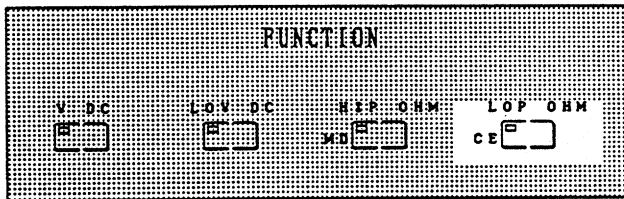

This key cancels all set data for currently input parameters (the data displayed in the display block).

R6561  
DIGITAL MULTIMETER  
OPERATION MANUAL

2.7 Description and Setting  
Method of Parameters

- ③  (CHANGE key)

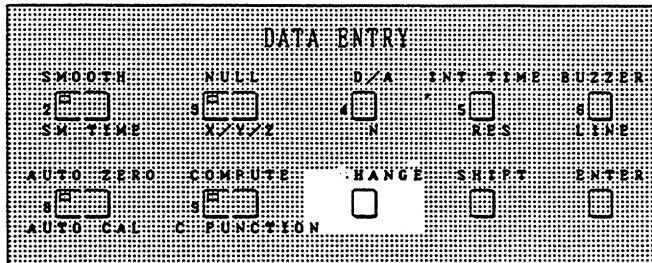

This key changes the setting of data in the display (ON/OFF, unit, and the number of display digits of various parameters).

- ④  (SHIFT key)

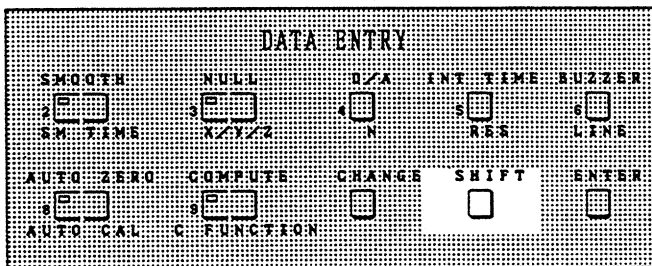

This key has two functions as follows:

- (a) A function to call parameters printed in blue under the key (RES, LINE, and TEST, etc.) to the display block.
- (b) A function to move a blinking display position

- ⑤  (ENTER key)

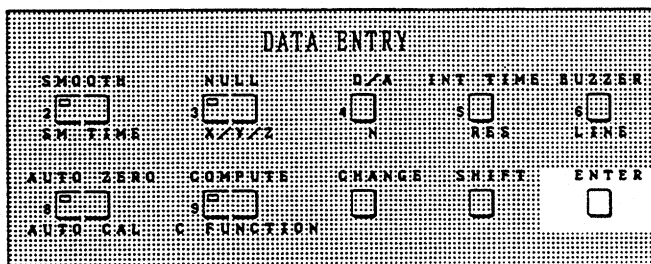

This key stores the set data in the internal memory.

R6561  
DIGITAL MULTIMETER  
OPERATION MANUAL

2.7 Description and Setting  
Method of Parameters

⑥  $\begin{matrix} \text{UP} \\ 0 \square \\ \text{HIGH} \end{matrix}$  to  $\begin{matrix} \text{COMPUTE} \\ 9 \square \\ \text{C FUNCTION} \end{matrix}$  (Numeric key)

After setting the following parameters,  $\begin{matrix} \text{UP} \\ 0 \square \\ \text{HIGH} \end{matrix}$  to  $\begin{matrix} \text{COMPUTE} \\ 9 \square \\ \text{C FUNCTION} \end{matrix}$  function as numeric keys:

- AUTO CAL
- C FUNCTION
- GPIB (address)
- HIGH
- LOW
- LIMIT
- N
- SM TIME
- X/Y/Z

That is, after selecting a parameter for which a numeric character is required,  $\begin{matrix} \text{UP} \\ 0 \square \\ \text{HIGH} \end{matrix}$  to  $\begin{matrix} \text{COMPUTE} \\ 9 \square \\ \text{C FUNCTION} \end{matrix}$  function as numeric keys.

⑦ When a parameter printed in blue is set, after pressing the SHIFT key, press the key on which the desired parameter is printed.

(2) Since the set content of each parameter is backed up by battery, it is not erased even if the power is turned OFF.

However, the following listed parameters are initialized at power ON.

- COMPUTE
- NULL
- SMOOTH

[Parameter Initializing Method]

The following is a description of initializing a parameter.

- ①  $\begin{matrix} \text{SHIFT} \\ \square \end{matrix}$
- ②  $\begin{matrix} \text{MODE} \\ \square \end{matrix}$
- ③  $\begin{matrix} \text{CLEAR} \\ \text{ENTER} \\ \square \end{matrix}$

CLEAR

R6561  
DIGITAL MULTIMETER  
OPERATION MANUAL

2.7 Description and Setting  
Method of Parameters

[Initial Value of Each Parameter]

Parameter	Initial Value
GPIB	This parameter value cannot be initialized.
LINE	This parameter value cannot be initialized.
FUNCTION	V DC
RANGE	AUTO (10V range)
SAMPLING MODE	RUN
INT TIME	5PLC
AUTO ZERO	ON
AUTO CAL	1 minute
NULL	OFF
BUZZER	OFF
D/A	OFF
COMPUTE	OFF
C FUNCTION	0-0 (OFF in both primary computing and secondary computing)
RES	6-1/2 digit mode
N	2
SMOOTH	OFF
SM TIME	10
X/Y/Z	X, Z = 1 Y = 0
HIGH	HIGH1, HIGH2 = 1
LOW	LOW1, LOW2 = 0
LIMIT	Reference value = 1 %1, %2 = 10%

2.7.1 INT TIME: Integrate Time

[Functional Description]

The INT TIME parameter is used to set the integrate time when this equipment executes A/D conversion.

- ① It is possible using this INT TIME parameter to select an integrate time which meets the measurement resolution and speed in a range from 1 PLC to 100 PLC from among the six ranges shown below. However, the 1 PLC cannot be set in the low voltage DC and resistance measuring functions.

1 PLC, 5 PLC, 10 PLC, 20 PLC, 50 PLC, and 100PLC

The PLC is the abbreviation for "Power-Line Cycle". The value of 1 PLC varies depending on the power supply frequency as follows:

- 1 PLC = 20msec when the power supply frequency is 50Hz
- 1 PLC = 16.7msec when the power supply frequency is 60Hz

By setting a greater integrate time, it becomes possible to make a measurement less affected by noise components.



[Setting Method]

The following is a description of setting the integrate time.

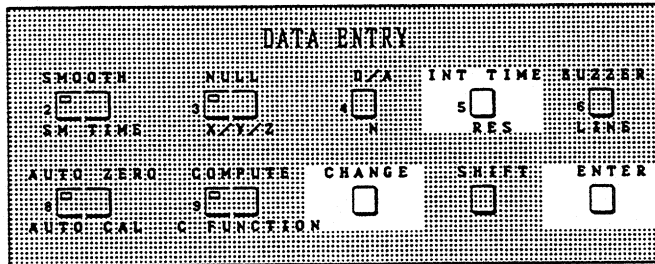

- INT TIME Parameter Setting

- ① Press the INT TIME key.

The previous set value of integrate time is displayed in the display block.

- Integrate Time Selection

- ② Press the CHANGE key and select an integrate time.

Each time the CHANGE key is pressed, the display in the display block changes as shown below:

┌ 1PL → 5PL → 10PL ─┐  
└ 100PL ← 50PL ← 20PL ┘

Press the CHANGE key to make the display block display the integrate time to be set.

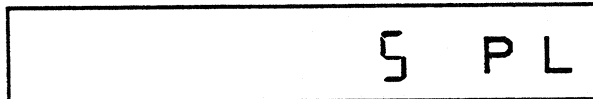

R6561  
DIGITAL MULTIMETER  
OPERATION MANUAL

2.7 Description and Setting  
Method of Parameters

- End of Integrated Time Setting

(3) Press the ENTER key.

The integrate time displayed in the display unit is stored in memory.

This completes the setting of integrate time.

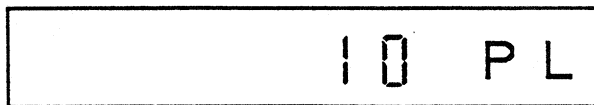

2.7.2 AUTO ZERO: Auto Zero Calibration

[Functional Description]

The AUTO ZERO parameter selects whether or not the offset error in the analog circuit system of this equipment is automatically eliminated.

[Setting Method]

The following is a description of turning the auto zero calibration function ON/OFF.

- AUTO ZERO Function ON/OFF Setting

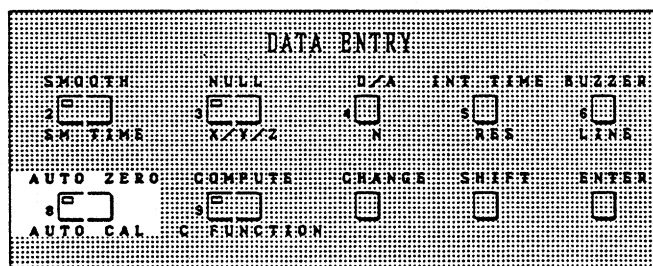

The AUTO ZERO function is turned ON/OFF using the AUTO ZERO key.

Each time the AUTO ZERO key is pressed, the lamp in the key switches. The AUTO ZERO function is ON when the lamp is ON and OFF when the lamp is OFF.

Since the auto zero calibration (same as the integrate time) is executed each time the measurement is made when the AUTO ZERO is set to ON, the time spent for measurement takes about double as compared with that in the AUTO ZERO OFF.

### 2.7.3 AUTO CAL: Auto Calibration Interval

#### [Functional Description]

The AUTO CAL parameter is used to set an interval for the execution of auto calibration.

This equipment executes a calibration of the measuring system on the basis of the internal reference voltage with a fixed period to maintain the stability of the measuring system.

The range can be set from 0 to 999 minutes at one minute intervals. When set to 0 minutes, the calibration mode becomes OFF.

#### [Setting Method]

The following is a description of setting the execution interval value of the auto calibration function.

#### - AUTO CAL Parameter Setting

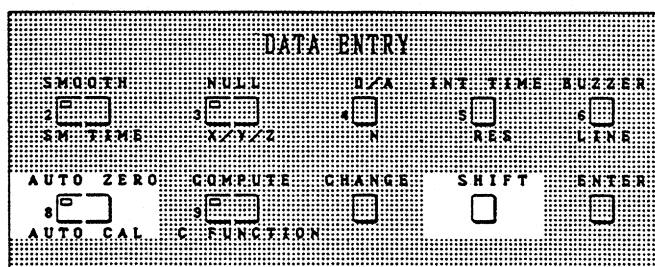

- ① Press the SHIFT key.
- ② Press the AUTO CAL key.

The display block displays the previous set value of the execution interval.

R6561  
DIGITAL MULTIMETER  
OPERATION MANUAL

2.7 Description and Setting  
Method of Parameters

- Execution Interval Value Setting

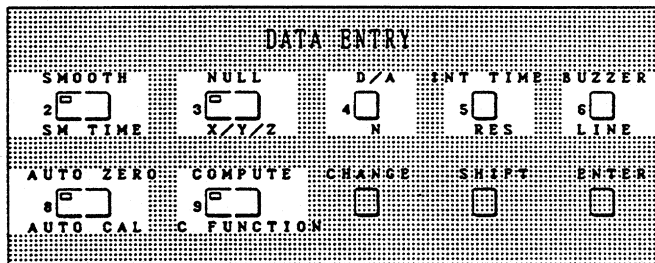
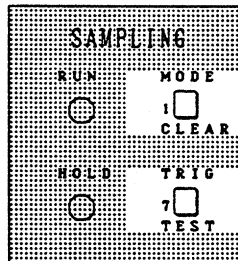
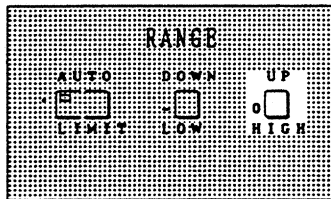

- ③ Set the execution interval value using numeric keys from 0 to 9.

When parameter AUTO CAL is set, 0 to 9 function as numeric keys.

(Example) To set to 360, press 3 6 0 .

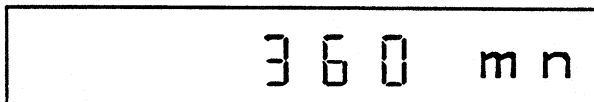

- End of Execution Interval Value Setting

- ④ Press the ENTER key.

The execution interval value displayed in the display block is stored in memory.

This completes the setting of the execution interval value.

2.7.4 BUZZER: Buzzer Mode

[Functional Description]

The BUZZER parameter selects whether or not the buzzer function is used. Three buzzer modes are provided for this system, as follows:

- (1) OFF : No buzzer function is used.
- (2) ON-1: If this mode is selected, the buzzer is activated when the computed result becomes R(H2), R(H1), R(L2), and R(L1) in the comparator computing.
- (3) ON-2: If this mode is selected, the buzzer is activated when the computed result becomes R(PASS) in the comparator computing.

Incidentally, when set to modes (2) and (3) above, the buzzer is also activated in the following states.

- When an error occurs
- When a panel key is pressed

[Setting Method]

The following is a description of setting the BUZZER parameter.

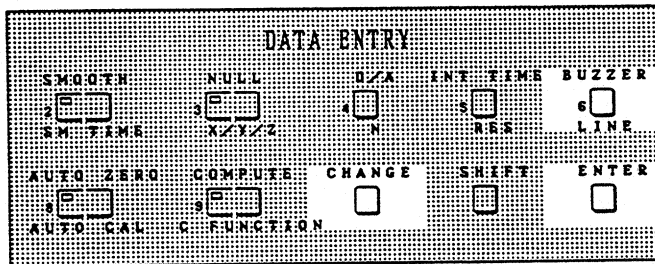

- BUZZER Parameter Setting

- ① Press the BUZZER key.

The previously set status of the buzzer mode is displayed in the display block.

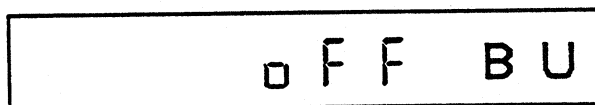

- BUZZER Mode Selection

- ② Select the BUZZER mode.

Three BUZZER modes are provided for this system as follows.

These modes are selected using the CHANGE key.

Each time the CHANGE key is pressed, the display in the display block changes as shown below:

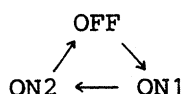

The mode to be selected is displayed in the display block.

- End of BUZZER Mode Setting

- ③ Press the ENTER key.

The BUZZER mode displayed in the display block is stored in memory.

This completes the setting of the BUZZER mode.

2.7.5 D/A: D/A Output Mode

[Functional Description]

The D/A parameter is used to set the mode to output the analog data from the D/A output pin of the rear panel.

It is possible to convert the low two or three digits of the measurement data into +0.999V (FULL SCALE) to output it. A linear output can be obtained by adding the offset value (500/50) when the D/A output data is in the vicinity of 0 or when it is FULL SCALE.

Since the following five output modes are provided for this system, select the mode depending on use.

- ① OFF (No analog output is made.)
- ② Low order three digits of the measurement data are output.
- ③ Low order three digits of the measurement data are output with the offset value (500) added.
- ④ Low order two digits of the measurement data are output.
- ⑤ Low order two digits of the measurement data are output with the offset value (50) added.

The selection of digits for output data is made using the RES parameter.

(Example) Change in the number of digits using the RES parameter

- ① 1199999: Low order two digits are output (by setting the RES parameter to 6-1/2 digit mode).
- ② 1199999: Low order three digits are output (by setting the RES parameter to 6-1/2 digit mode).
- ③ 119999 : Low order two digits are output (by setting the RES parameter to 5-1/2 digit mode).
- ④ 119999 : Low order three digits are output (by setting the RES parameter to 5-1/2 digit mode).

R6561  
DIGITAL MULTIMETER  
OPERATION MANUAL

2.7 Description and Setting  
Method of Parameters

Output Mode:

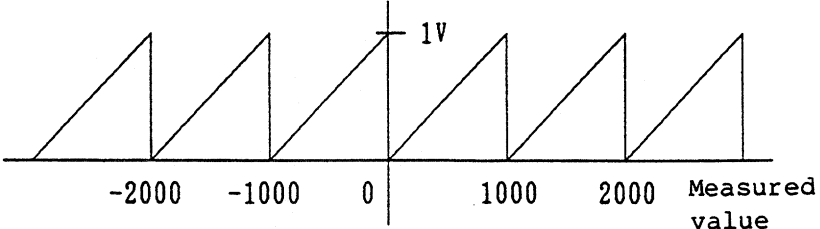
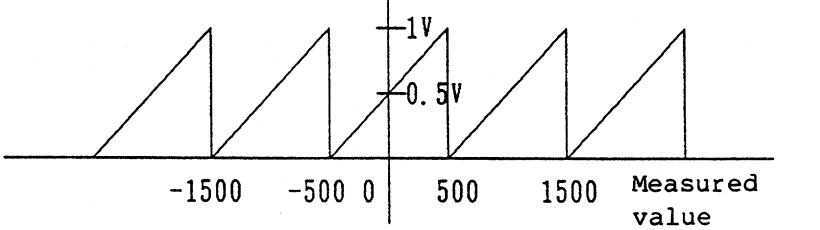
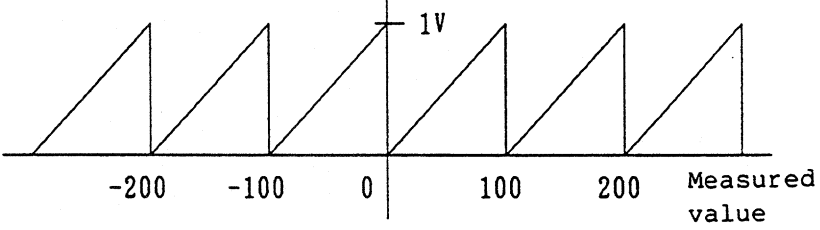
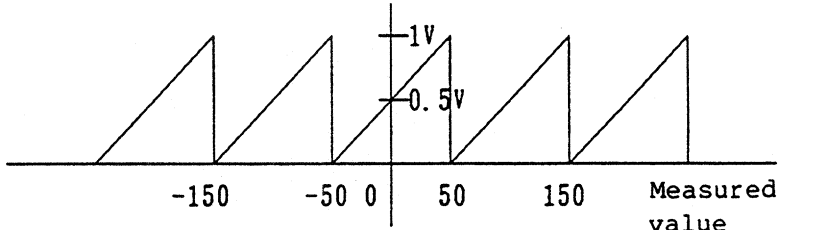
Output mode	Analog output
Low order three digits of the displayed value	<p data-bbox="847 546 1074 577">Output voltage</p> 
Low order three digits of the displayed value +OFFSET(500)	<p data-bbox="847 864 1074 896">Output voltage</p> 
Low order two digits of the displayed value	<p data-bbox="847 1189 1074 1220">Output voltage</p> 
Low order two digits of the displayed value +OFFSET(500)	<p data-bbox="847 1507 1074 1538">Output voltage</p> 
OFF	Output voltage 0V



[Setting Method]

The following describes the setting of the analog output mode.

- D/A Parameter Setting

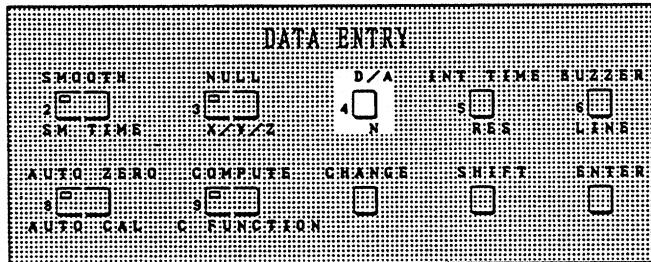

- ① Press the D/A key.

The output digit and the previous set status of the offset value are displayed in the display block.

The output digit blinks at this time.

Output digit    Offset value

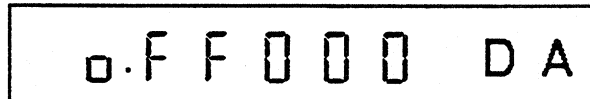

Blinking

- Output Digit/Offset Value Selection

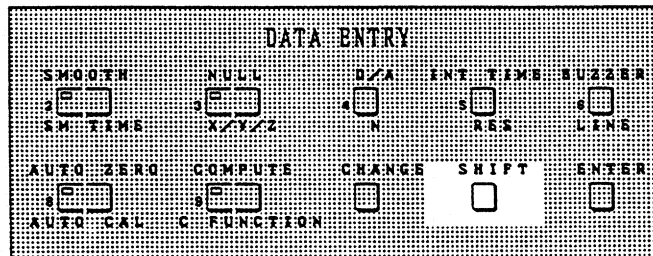

- ② The setting of the analog output mode is done in two ways. One is the setting of the output digit and the other of the offset value. One of the two is selected in this example.

R6561  
DIGITAL MULTIMETER  
OPERATION MANUAL

2.7 Description and Setting  
Method of Parameters

Either one of the two, output digit or offset value, may be set first.

Press the SHIFT key and set one of the two, output digit or offset, to cause it to blink.

Each time the SHIFT key is pressed, the output digit and offset value blink alternately.

- (a) When the output digit mode (OFF, low order three digits, or low order two digits) is set

Press the SHIFT key to make the output digit blink, then proceed to step ③.

Output digit    Offset value  
display        display

8 8 8 0 0 0    D A

Blinking

- (b) When the offset value (0.500) is set

Press the SHIFT key to make the offset value blink, then proceed to step ④.

Output digit    Offset value  
display        display

8 8 8 0 0 0    D A

Blinking

R6561  
DIGITAL MULTIMETER  
OPERATION MANUAL

2.7 Description and Setting  
Method of Parameters

- Output Digit Selection

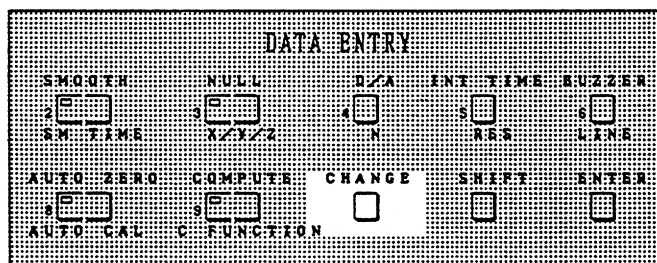

- ③ Select the output digit mode (OFF, low order three digits, or low order two digits). This selection is made using the CHANGE key.

Each time the CHANGE key is pressed, the display changes as shown below:

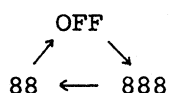

The selected mode is displayed.

- Offset Value Selection

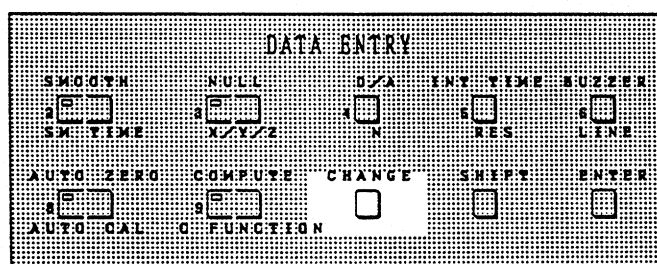

- ④ Select the offset value (0.500). This selection is made using the CHANGE key.

Each time the CHANGE key is pressed, the display changes as shown below:

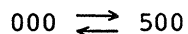

The offset value to be selected is displayed.

R6561  
DIGITAL MULTIMETER  
OPERATION MANUAL

2.7 Description and Setting  
Method of Parameters

- End of Output Digit/Offset Value Setting

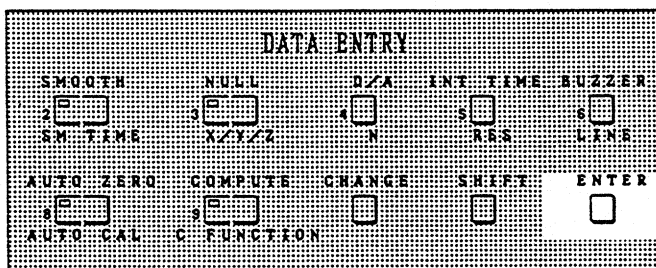

⑤ Press the ENTER key.

The output digit and offset value displayed in the display block are stored in the memory.

This completes the analog mode output mode setting.

2.7.6 C FUNCTION: Computing Function

[Functional Description]

The C FUNCTION parameter is used to select the computing function of this equipment.

For details of the computing function, see Chapter 3. COMPUTING FUNCTION.

Table 2-3 shows the details of primary and secondary computing.

Table 2 - 3 Computing Function

Data	Primary computing	Secondary computing
0	OFF	OFF
1	Scaling	Comparator 1
2	% deviation	Comparator 2
3	Delta	Statistical processing
4	Multiply	/
5	Decibel conversion	
6	Effective value	
7	dBm conversion	
8	Resistance value temperature correction	

[Setting Method]

The following describes the setting of the computing function.

- C FUNCTION Parameter Setting

- ① Press the SHIFT key.
- ② Press the C FUNCTION key.

The display block displays the previous setting of the primary computing and secondary computing.

At this time, the set data for the primary computing blinks.

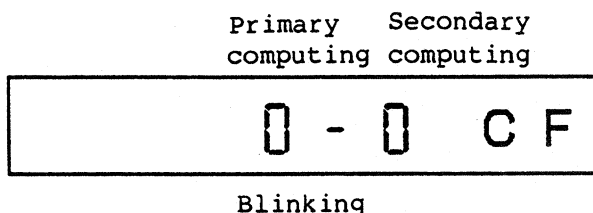

- Computing Function Selection

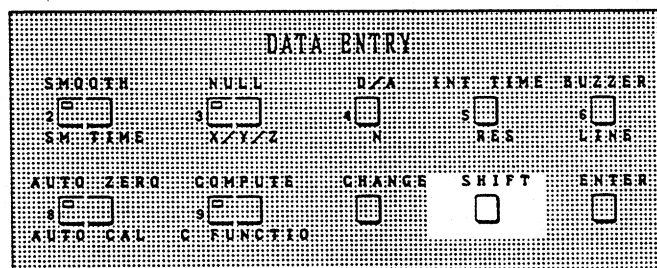

- ③ The setting of the computing function is made in two ways—the setting of primary computing and that of secondary computing. One of the two settings is selected in this example. Either primary or secondary computing may be set first.

Press the SHIFT key to cause the primary computing or secondary computing display, whichever is set, to blink. Each time the SHIFT key is pressed, the primary computing and secondary computing displays blink alternately.

R6561  
DIGITAL MULTIMETER  
OPERATION MANUAL

2.7 Description and Setting  
Method of Parameters

(Example)

- When the primary computing is set  
Press the SHIFT key to make the primary computing display blink.
- When the secondary computing is set  
Press the shift key to make the secondary computing display blink.

[When the Both Primary and Secondary Computing are Set]

Both the primary computing and secondary computing can be set by a single operation. The method will be described in the next step ④.

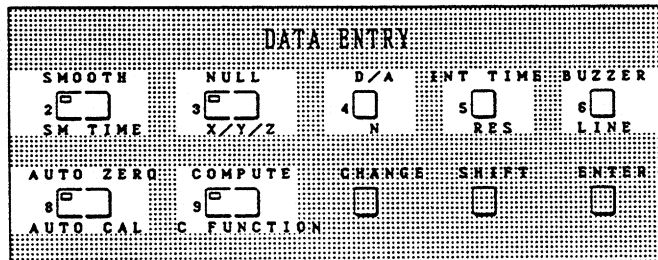
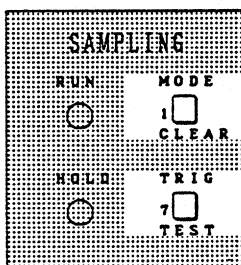
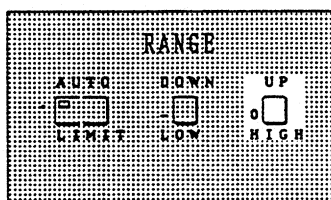

④ Set the computing function.

This setting is made using numeric keys 0 to 8.

The setting can be made from 0 to 8 for the primary computing and from 0 to 3 for the secondary computing.

The computing function can be set if its display is blinking.

(Example)

- Press 1 when the scaling is set to the primary computing function.

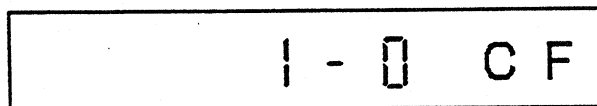

Blinking Ligthed

R6561  
DIGITAL MULTIMETER  
OPERATION MANUAL

2.7 Description and Setting  
Method of Parameters

---

- Press  $\square$  when the comparator 2 is set to the secondary computing function.

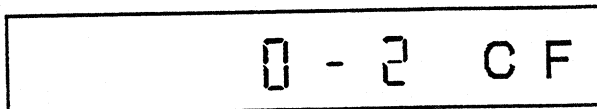

Lighted Blinking

For the primary/secondary computing function data, see Table 2-3.

[When the Primary Computing and Secondary Computing are Set Simultaneously]

Set the primary computing. The indicator of the primary computing will then light and that of the secondary computing blink.

Then set the secondary computing. The secondary computing indicator lights and the primary computing indicator blinks again.

When the both computing functions are set, ignore the blinking and proceed to step ⑤. The step for this setting can also be made from that of the secondary computing.

- End of Computing Function Setting

- ⑤ Press the ENTER key.

The computing function displayed in the display block is stored in the internal memory. This completes the setting of the computing function.

#### 2.7.7 RES: Resolution

[Functional Description]

The RES parameter is used to set the number of measuring digits.

Noteworthy points are as follows:

- ① The number of digits which can be set is 4-1/2, 5-1/2, or 6-1/2 digit.
- ② Priority of the Number of Measuring Digits

The setting by the RES parameter has priority over the setting by a measuring function in the number of measuring digits.

R6561  
DIGITAL MULTIMETER  
OPERATION MANUAL

2.7 Description and Setting  
Method of Parameters

---

The relationship between the measuring functions and the number of measuring digits is shown in Table 2-4. That is, when a measuring function is set to a range of  $1000\Omega$  in the LO-P mode resistance measurement, the actual number of display digits becomes 4-1/2 digit even if the number of measuring digits is set to 6-1/2 digit by the RES parameter.

③ Relationship between the Number of Measuring Digits and Range

The number of digits in the integral part of the number of measuring digits becomes the same as the maximum number of digits in the selected measuring range.

(Example)

- (a) When the 4-1/2 digit measurement and HI-P OHM  $100\Omega$  range are selected, the measurement value becomes 2-1/2 digit (because 100 is 2-1/2 digit) with 2 digits in the decimal part as shown below:

108.83	$\Omega$
--------	----------

57.26	$\Omega$
-------	----------

- (b) When the 6-1/2 digit measurement and HI-P OHM  $100\Omega$  range are selected, the measurement value becomes 2-1/2 digit (because 100 is 2-1/2 digit) with 4 digits in the decimal part as shown below:

108.8334	$\Omega$
----------	----------

57.2616	$\Omega$
---------	----------

④ Meaning of 1/2 Digit in the 6-1/2 Digit Measurement

When the  $1000\Omega$  range is selected, for instance, the maximum measurement value becomes  $1199.999\Omega$ . At this time, the highest order digit to be displayed is 1 only, and because no other value can be displayed but 1, the highest digit is counted as a 1/2 digit.



R6561  
DIGITAL MULTIMETER  
OPERATION MANUAL

2.7 Description and Setting  
Method of Parameters

Table 2 - 4 Relationship between Measuring Functions and  
the Number of Display Digits

Measuring function		Range	Maximum number of display digits
DC voltage measurement		1000mV	Displayed in 6-1/2 digit
		10V	
		100V	
		500V	
Low voltage DC measurement		1000μV	Displayed in 5-1/2 digit
		10mV	Displayed in 6-1/2 digit
		100mV	
		1000mV	
		10V	
Resistance measurement	HI-P mode	1000mΩ	Displayed in 6-1/2 digit
		10Ω	
		100Ω	
		1000Ω	
	LO-P mode	10kΩ	Displayed in 5-1/2 digit
		100mΩ	Displayed in 5-1/2 digit
		1000mΩ	
		10Ω	
100Ω			
		1000Ω	Displayed in 4-1/2 digit

[Setting Method]

The following describes the setting of the number of measuring digits.

- RES Parameter Setting

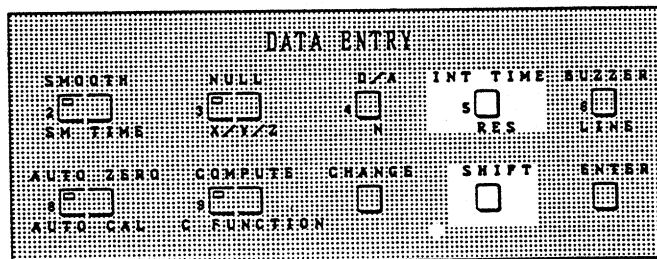

① Press the SHIFT key.

② Press the RES key.

R6561  
DIGITAL MULTIMETER  
OPERATION MANUAL

2.7 Description and Setting  
Method of Parameters

The display block displays the previous setting of the number of measuring digits.

The 4-1/2 digit are displayed as shown below:

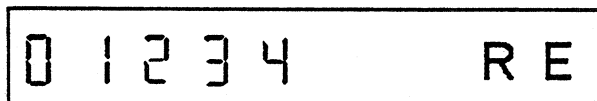

- Selection of Number of Measuring Digits

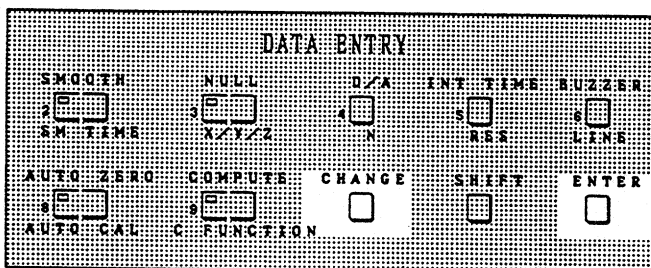

- ③ Select the number of measuring digit (4-1/2, 5-1/2, or 6-1/2 digit). The selection is executed using the CHANGE key.

Each time the CHANGE key is pressed, the number of measuring digits changes as shown below:

4-1/2 digit  
 ↗ ↘  
 6-1/2 digit ← 5-1/2 digit

The display for each digit is shown below:

- 5-1/2 digit

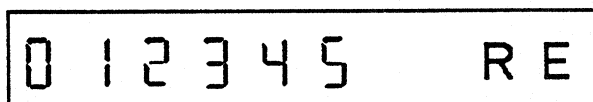

- 6-1/2 digit

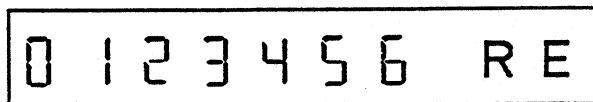

The number of measuring digits to be set displayed in the display block.

- End of Measuring Digit Setting

④ Press the ENTER key.

The number of measuring digits displayed in the display block is stored in the internal memory. This completes the setting of the number of measuring digits.

### 2.7.8 N

[Functional Description]

The N parameter is used to set the number of data setting times for the statistical process computing. The possible range is from 2 to 10000.

[Setting Method]

The following describes the setting of the constant N.

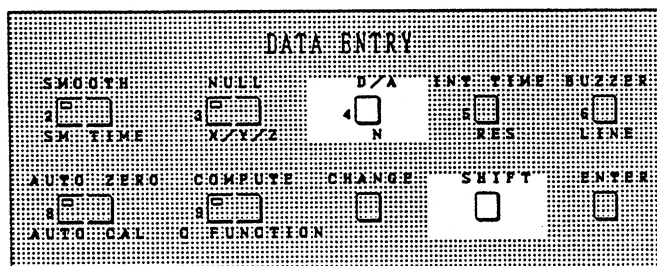

① Press the SHIFT key.

② Press the N key.

The display block displays the previous set value of constant N.

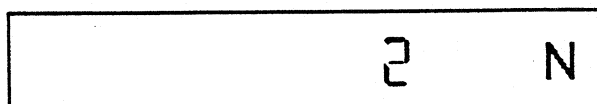

R6561  
DIGITAL MULTIMETER  
OPERATION MANUAL

2.7 Description and Setting  
Method of Parameters

- Setting of Constant

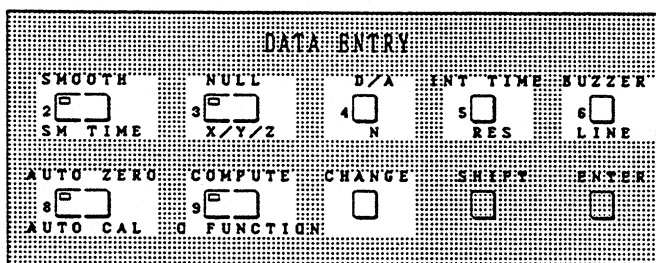
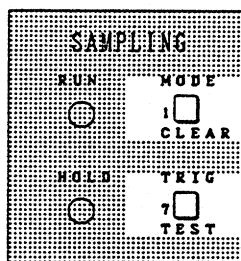
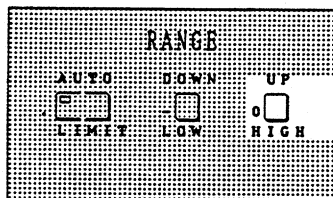

- ③ The value of the constant N is set using numeric keys, 0 to 9. When the parameter N is set, 0 to 9 function as numeric keys. The display block displays the set value.

(Example)

Press 6 3 .

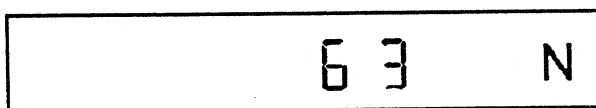

- End of Constant Setting

- ④ Press the ENTER key. The value displayed in the display block is stored in the memory. This completes the setting of the constant N.

2.7.9 X/Y/Z

[Functional Description]

Parameters X, Y, and Z are used to set the constant contained in the computing expression.

It is also possible to set the previous measured value or the result of computation can be set as the constant using the MD key.

The possible range for setting the constant is from  $\pm 1999999E-9$  to  $\pm 1999999E+9$ .

Since the parameter, X, Y, or Z, to be used as a constant varies according to the computing mode, check the parameter corresponding to the computing mode, then make the setting. [See Chapter 3. COMPUTING FUNCTION.]

[Setting Method]

The following describes the setting of the constant X, Y, or Z.

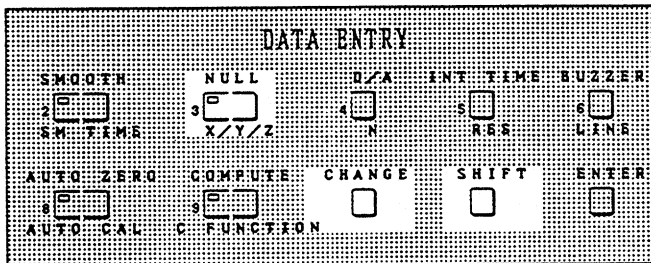

- Setting of Parameter X/Y/Z

- ① Press the SHIFT key.
- ② Press X/Y/Z key.

The display block displays the previous set value of constant X.

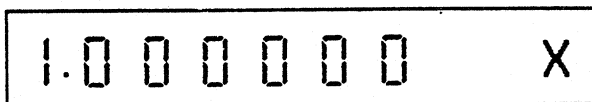

- Selection of Constant

- ③ Select a constant to be set. The selection of constant is made using the CHANGE key.

R6561  
DIGITAL MULTIMETER  
OPERATION MANUAL

2.7 Description and Setting  
Method of Parameters

Each time the CHANGE key is pressed, the display changes as shown below:

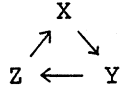

The constant to be set is displayed in the display block.

(Example)

- When constant Y is set

Press the CHANGE key once to display Y in the display block.



[When Two or More Constants are Set]

One constant only is set in one setting operation. When three constants, X, Y, and Z, are set, perform the setting operation three times.

- Setting of Constant

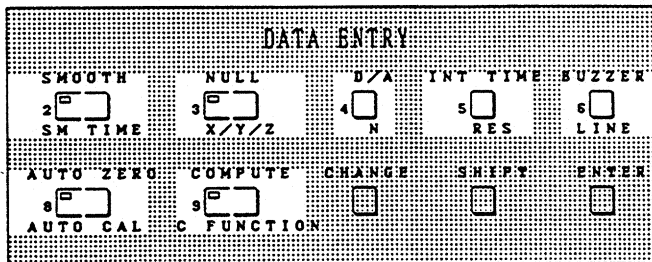
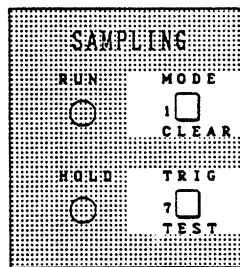
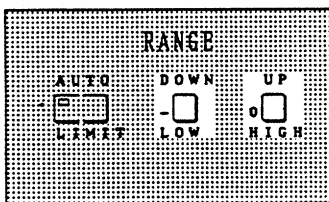

- ④ Set a constant in two stages, the mantissa and the exponent. Set the mantissa first, followed by the exponent.

(a) Setting Mantissa

The value displayed in the selection of a constant is the mantissa. The setting is made using numeric keys, 0 to 9. When parameter X/Y/Z is set, the 0 to 9 function as numeric keys.

The display block displayed the set value.

(Example) When set to 18

Press 1 8 .

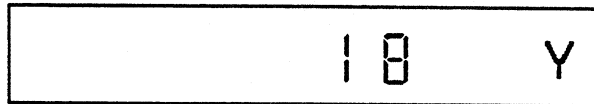

18 Y

(b) Setting Exponent

When setting the exponent display it in the display block.

For this display, after setting the mantissa, press the SHIFT key. The display block changes as shown below:

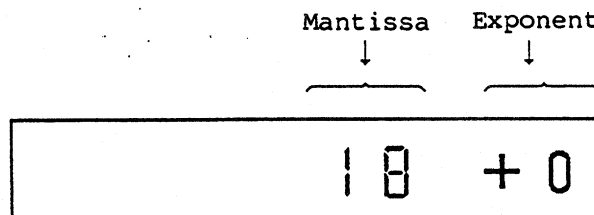

Mantissa Exponent  
↓ ↓  
18 + 0

When a numeric key is pressed at this stage, the value in the exponent part changes.

Using the numeric key, display the value to be set as the exponent part.

R6561  
DIGITAL MULTIMETER  
OPERATION MANUAL

2.7 Description and Setting  
Method of Parameters

(Example) When set to -3

Press  .

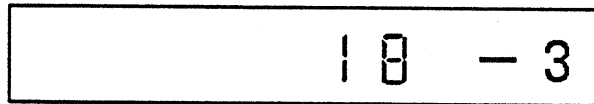

- End of Setting of Constant

- ⑤ Press the ENTER key.

The value displayed in the display block is stored in memory. This completes the setting of the constant.

To set another constant, repeat the setting operation from the beginning.

2.7.10 LOW

[Functional Description]

The LOW parameter is used to set the lower limit value of the comparator 1 computing. The possible range is from  $\pm 1999999E-9$  to  $\pm 1999999E+9$ .

[Setting Method]

The following describes the setting of the LOW1 and LOW2 constants.

- Parameter LOW Setting

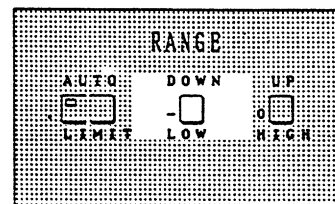
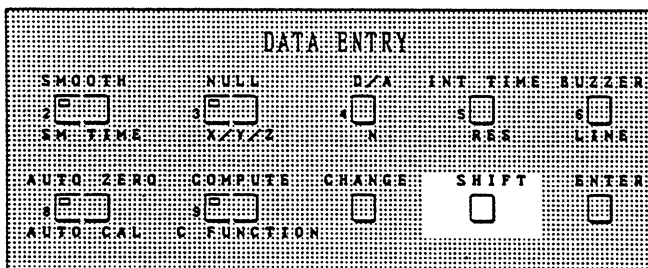

- ① Press the SHIFT key.  
② Press the LOW key.



R6561  
DIGITAL MULTIMETER  
OPERATION MANUAL

2.7 Description and Setting  
Method of Parameters

The display block displays the previous set value of constant L1 (LOW1).



- Selection of Constant

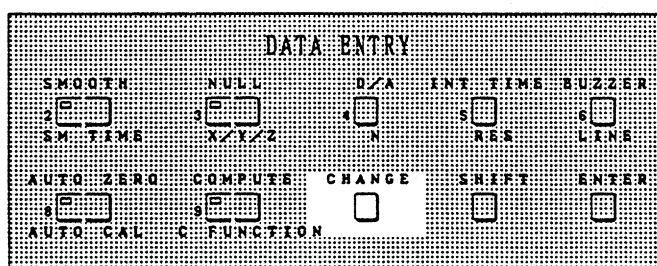

③ Select a constant.

The selection of a constant is made using the CHANGE key. Each time the CHANGE key is pressed, the display changes as shown below:

L1 (LOW1)  $\longleftrightarrow$  L2 (LOW2)

The constant to be set is displayed in the display block.

(Example) When L2 is set

Press the CHANGE key once to display L2 in the display block.



[When Two or More Constants are Set]

Only one constant can be set in one setting operation. When two constants, LOW1 and LOW2, are to be set, perform the setting operation twice.

R6561  
DIGITAL MULTIMETER  
OPERATION MANUAL

2.7 Description and Setting  
Method of Parameters

- Setting of Constant

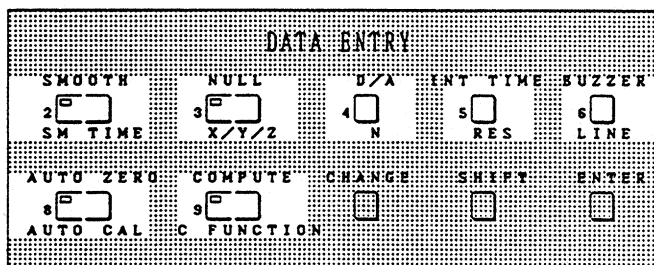
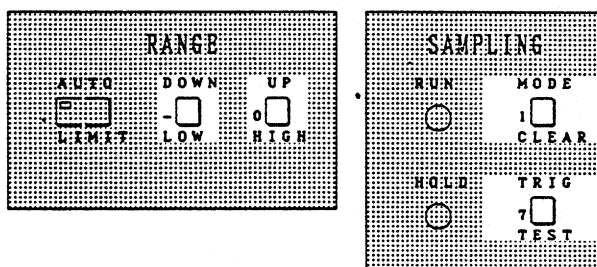

④ Set a constant in two stages - the mantissa and the exponent.

(a) Setting Mantissa

The value displayed in the selection of a constant is the mantissa. It is set using numeric keys, 0 to 9. When parameter LOW is set, the 0 to 9 function as numeric keys.

The display block displays the set value.

(Example) When set to 18

Press 1 8 .

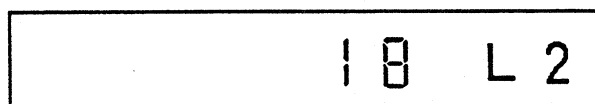

(b) Setting Exponent

To set the exponent display the exponent in the display block.

For this display, after setting the mantissa, press the SHIFT key. Then, the display in the display block changes as shown below:



- Setting HIGH Parameter

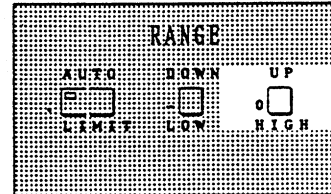
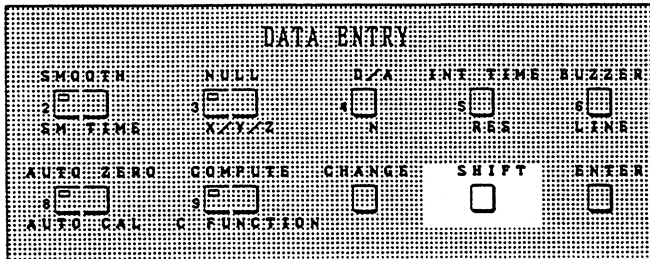

- ① Press the SHIFT key.
- ② Press the HIGH key.

The display block displays the previous set value of constant H1 (HIGH1).

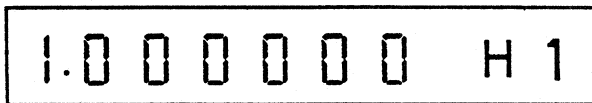

- Selection of Constant

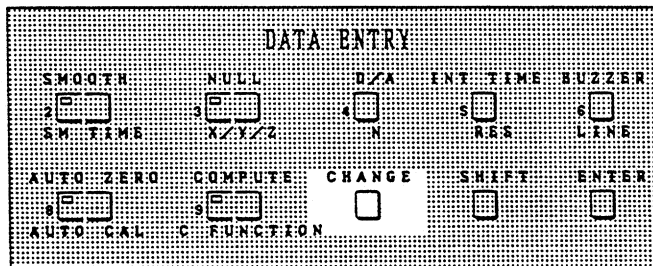

- ③ Select a constant to be set.

The selection of the constant is made using the CHANGE key. Each time the CHANGE key is pressed, the display changes as shown below:

H1 (HIGH1)  $\longleftrightarrow$  H2 (HIGH2)

The constant to be set is displayed in the display block.

R6561  
DIGITAL MULTIMETER  
OPERATION MANUAL

2.7 Description and Setting  
Method of Parameters

(Example) When H2 is set

Press the CHANGE key once to display H2 in the display block.

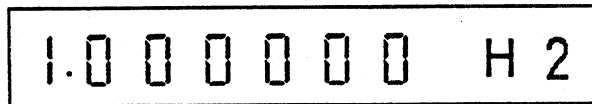

[When Two or More Constants are Set]

Only one constant can be set in one setting operation. When two constants, HIGH1 and HIGH2, are set, perform the setting operation twice.

- Setting of Constant

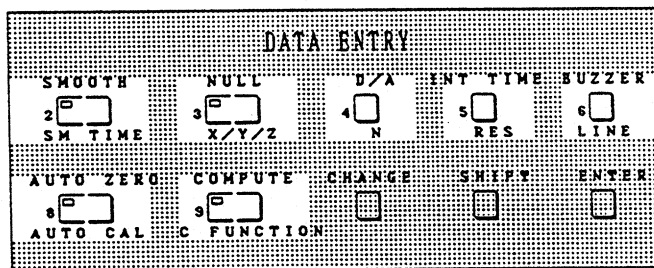
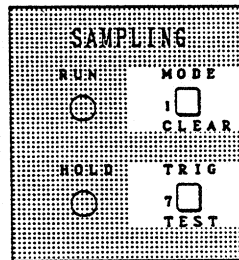
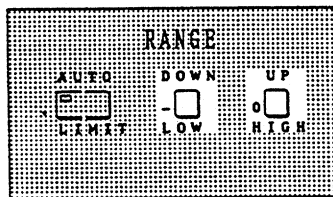

- ④ Set a constant in two stages - mantissa and exponent.

Set mantissa first, followed by the exponent.

(a) Setting Mantissa

The value displayed in the selection of a constant is the mantissa. This setting is made using numeric keys, 0 to 9. When the HIGH parameter is set, the 0 to 9 function as numeric keys. The display block displays the set value.

R6561  
DIGITAL MULTIMETER  
OPERATION MANUAL

2.7 Description and Setting  
Method of Parameters

---

(Example) When set to 18

Press 1□.□.

18 H 2

(b) Setting of Exponent

To set the exponent, display the exponent in the display block.

For this display, after setting the mantissa, press the SHIFT key. Then, the display in the display block changes as shown below:

Mantissa      Exponent  
↓                    ↓  
└───┬───┘      └───┬───┘  
18                + 0

When a numeric key is pressed in this stage, the value in the exponent part changes.

Use the numeric key to display the value to be set in the exponent.

(Example) When set to +2

Press 2□.

18 + 2

- End of Setting of Constant

⑤ Press the ENTER key.

The value displayed in the display block is stored in memory. This completes the setting of the constant.

When another constant is set, repeat this setting operation from the beginning.

2.7.12 LIMIT

[Functional Description]

The LIMIT parameter is used to set the reference value and tolerance of the comparator 2 computing. The possible range is from  $\pm 19999999E-9$  to  $\pm 19999999E+9$  (except 0) in the reference value and (%) 0.000 to 100.0 (a real number in less than four digits) in the tolerance.

[Setting Method]

The following describes the setting of the constant LIMIT (reference value, %1, and %2).

- Setting of LIMIT Parameter

- ① Press the SHIFT key.
- ② Press the LIMIT key.

The display block displays the previous set value of reference value  $li$ .



- Selection of Constant

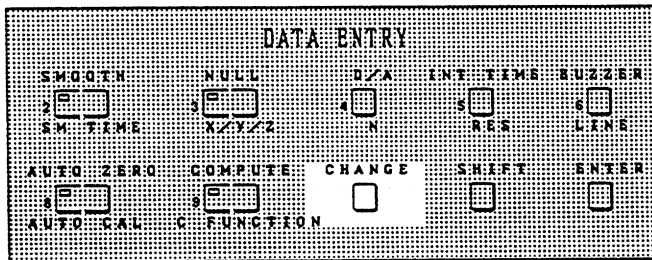

R6561  
DIGITAL MULTIMETER  
OPERATION MANUAL

2.7 Description and Setting  
Method of Parameters

- ③ Select a constant to be set.

The selection of the constant is made using the CHANGE key. Each time the CHANGE key is pressed, the display changes as shown below.

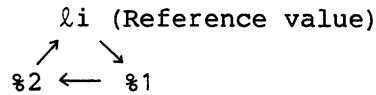

The constant to be set is displayed in the display block.

(Example) When %1 is set

Press the CHANGE key once to display %1 in the display block.

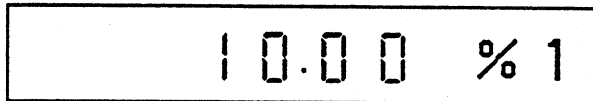

[When Two or More Constants are Set]

Only one constant can be set in one setting operation. When three constants reference value, %1, and %2 are set, perform the setting operation three times.

- Setting of Constant

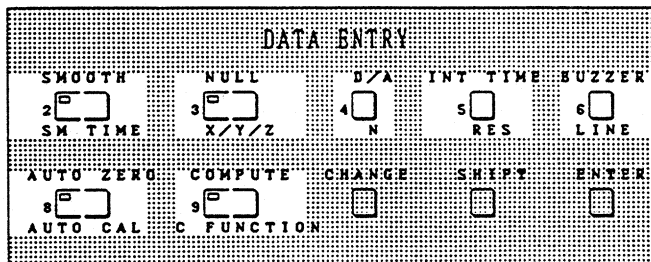
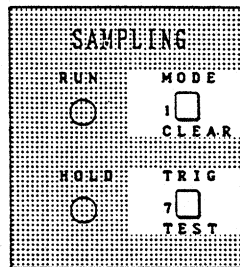
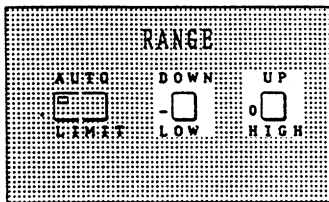



- ④ The setting of a constant is divided into two cases. One is to set the reference value and the other to set %1 and %2.
- ④ -1 When the reference value is set

The reference value is set in two stages - the mantissa and the exponent. Set the mantissa first, followed by the exponent.

(a) Setting Mantissa

The value displayed in the selection of a constant is the mantissa. It is set using numeric keys, 0 to 9. When parameter LIMIT is set, the 0 to 9 function as numeric keys.

The display block displays the set value.

(Example) When set to 18

Press 1 8 .

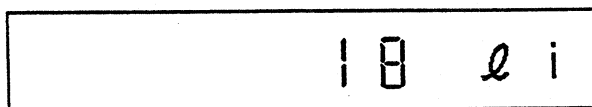

18 e |

(b) Setting exponent

To set the exponent, display the exponent in the display block.

After setting the mantissa, press the SHIFT key. The display in the display block changes as shown below:

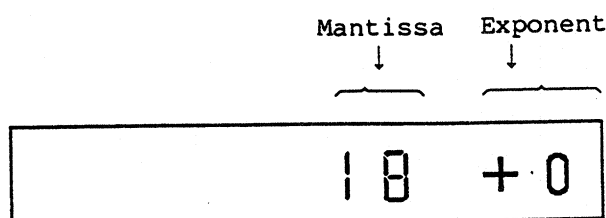

Mantissa Exponent  
↓ ↓  
18 +0

When a numeric key is pressed at this stage, the value in the exponent changes.

Use the numeric key to display the value to be set as the exponent.

(Example) When set to -3

Press -□:□.

18 - 3

④-2 When %1 and %2 are set

This setting is made using numeric keys □ to □. When the LIMIT parameter is set, the □ to □ function as numeric keys.

The display block displays the set value.

(Example) When set to 25

Press :□:□.

25 % 1

- End of Setting of Constant

⑤ Press the ENTER key.

The value displayed in the display block is stored in memory. This completes the setting of the constant.

To set another constant, repeat this setting operation from the beginning.

2.7.13 GPIB: GPIB Address Switch

[Functional Description]

When the GPIB is employed in this equipment, the parameter GPIB is used to set the format mode when the device address, address mode, and measurement data of this equipment are output.

When the address mode is set to "Addressable", the address can be specified from the controller.

When the address mode is set to "only", the system is converted to the "Talk only" mode and the data is transmitted irrespective of the external address specification. The address can be set from 0 to 30.

The GPIB parameter data is not initialized.

[Setting Method]

The following describes the setting of the parameter GPIB

- GPIB Parameter Setting

- ① Press the SHIFT key.
- ② Press the GPIB key.

The display block displays the currently set GPIB address parameter data.

H - A - 0 1 G P

[Description of Parameter Data Displayed in Display Block]

The parameter data is composed of three parts as follows:

The part where "H" is displayed : Format mode  
The part where "A" is displayed : Address mode  
The part where "01" is displayed: Address

The following describes each of these three parts.

(a) Format Mode

The format mode is classified into ON or OFF in header.

When the header is ON : Display of "H"  
When the header is OFF: Display of "\_" (underline)

(b) Address Mode

The address mode is specified as "Addressable" or "Talk only".

When specified as "Addressable": Display of "A"  
When specified as "Talk only" : Display of "o"

(c) Address

The address can be set in 31 numerics, "00" to "30".

R6561  
DIGITAL MULTIMETER  
OPERATION MANUAL

2.7 Description and Setting  
Method of Parameters

- Parameter Data Selection

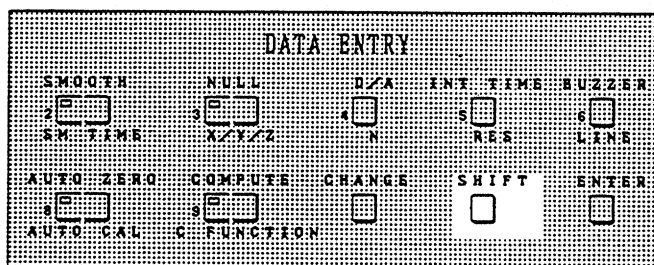

- ③ Select the parameter data. The parameter data contains the format mode, address mode, and address.

The selection is made using the SHIFT key. The parameter data to be set is caused to blink in the display block. Each time the SHIFT key is pressed, the blinking display position moves as shown below:

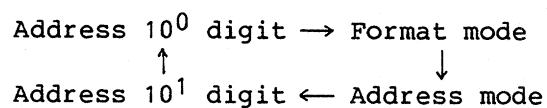

- Address Setting

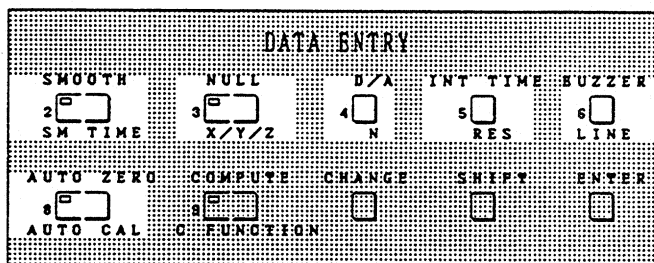
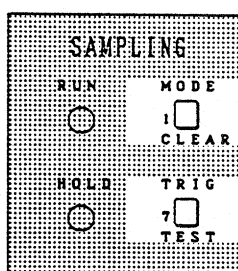
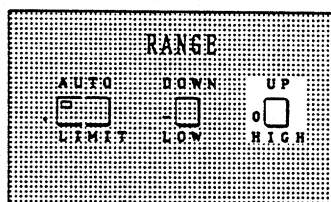

R6561  
DIGITAL MULTIMETER  
OPERATION MANUAL

2.7 Description and Setting  
Method of Parameters

- ④ Press the SHIFT key to make the address blink. A numeric value can be set to the blinking display position. Since either address of  $10^1$  digit or  $10^0$  blinks, set a numeric value using the numeric key. At this time, the blinking display position moves to left or right by one digit. (The position moves to right when the  $10^1$  digit data is input and to left when the  $10^0$  digit data is input.)

Set the numeric value of  $10^1$  digit and  $10^0$  digit.

(Example) When the address is set to "25"

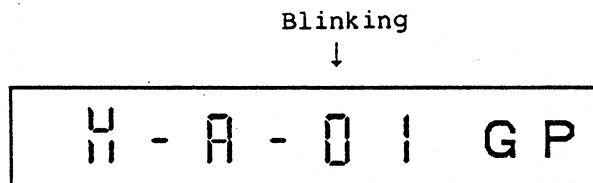

Press 2 .

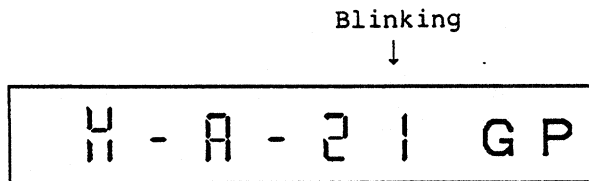

Press 5 .

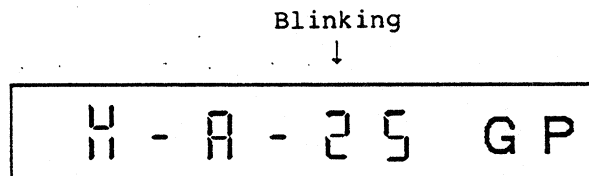

- Address Mode Setting

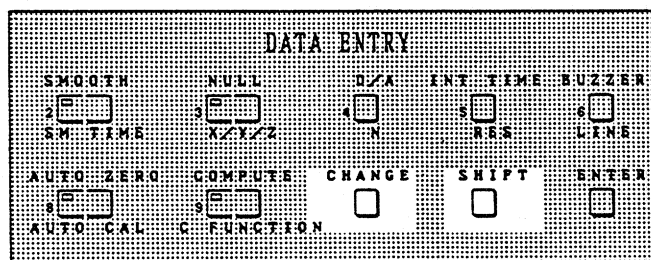

R6561  
DIGITAL MULTIMETER  
OPERATION MANUAL

2.7 Description and Setting  
Method of Parameters

- ⑤ Press the SHIFT key to cause the address mode to blink.

The address mode is specified as "A" (Addressable) or "o" (Talk only). The selection of address mode is made using the CHANGE key.

Each time the CHANGE key is pressed, the display changes as shown below:

"A" ↔ "o"

The address mode to be set is displayed in the display block.

- Format Mode Setting

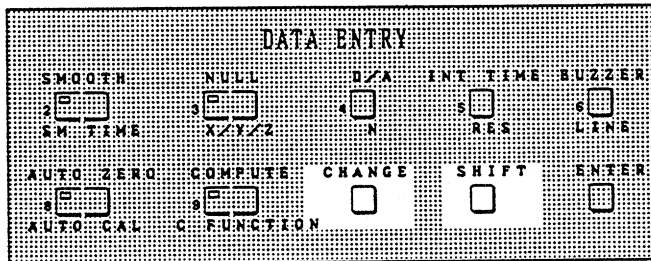

- ⑥ Press the SHIFT key to make the format mode blink.

The format mode is specified to two ways of "H" and "\_". The selection of format mode is made using the CHANGE key. Each time the CHANGE key is pressed, the display changes as shown below:

"H" ↔ "\_"

The format mode to be set is displayed in the display block.

- End of GPIB Parameter Setting

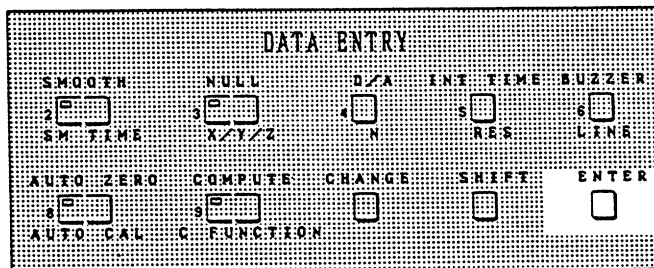

- ⑦ Press the ENTER key.

The parameter data displayed in the display block is stored in memory. This completes the setting of the GPIB parameter.

#### 2.7.14 LINE: Line Frequency

##### [Functional Description]

The LINE parameter is used to set the power supply frequency (50Hz or 60Hz) of this equipment.

The LINE parameter data is not initialized.

##### [Setting Method]

The following describes the setting of the power supply frequency.

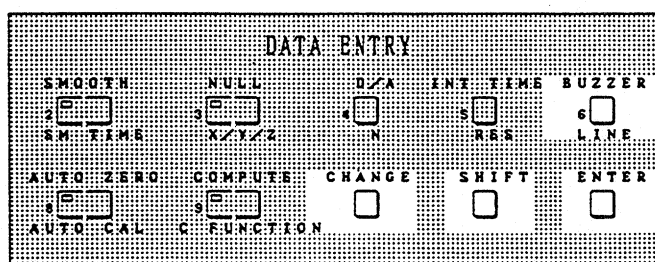

##### - LINE Parameter Setting

- ① Press the SHIFT key.  
② Press the LINE key.

The display block displays the previous set value of the power supply frequency.

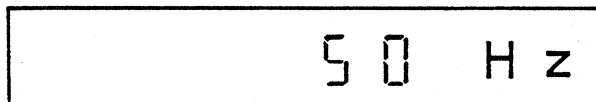

- Power Supply Frequency Selection

- ③ Select the power supply frequency (50Hz or 60Hz).

This selection is made using the CHANGE key. Each time the CHANGE key is pressed, the display changes as shown below:

50Hz  $\leftrightarrow$  60Hz

The power supply frequency to be set is displayed on the display block.

- End of Power Supply Frequency Setting

- ④ Press the ENTER key.

The power supply frequency displayed in the display block is stored in memory. This completes the setting of the power supply frequency.

2.7.15 SMOOTH: Smoothing

[Functional Description]

The SMOOTH parameter is used to execute the smoothing function.

This function is used when noise is superimposed on the measuring signal.

This function minimizes the dispersion of measured values because it makes the moving average value of a specified number of smoothing operations (hereinafter referred to as smoothing times) obtained from raw measured values the measured value.

The following is a description of the moving average value (a measured value after smoothing).

The moving average value (measured value after smoothing) is an average value of T pieces of measured values which are made of (T - 1) pieces of measured values immediately before the smoothing plus measured values to be smoothed. Where, T indicates the set number of smoothing operations.

Until the smoothing reaches the number of smoothing times from the start, however, an average value of previously measured values is displayed in the displayed block.

Figure 2-1 shows a case where the smoothing times (T) is four.



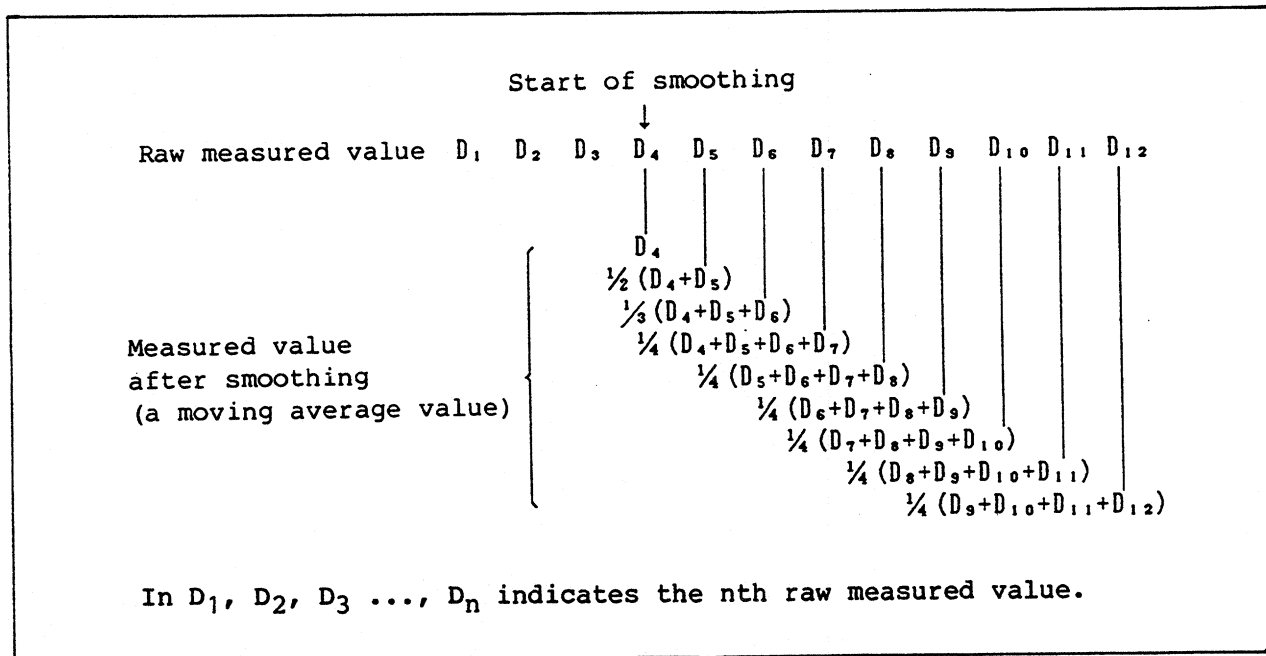

Figure 2 - 1 Relationship between Raw Measured Value and Measured Value After Smoothing

In general, measured value D (Sm) after smoothing in the nth

$$\text{measurement is expressed by } D(\text{sm}) = \frac{1}{T} \sum_{i=n-T+1}^n D_i.$$

Where,

- D<sub>i</sub> : Measured value before smoothing
- D (Sm): Measured value after smoothing
- T : Number of smoothing times (The possible range is from 2 to 100 expressed as an integer)

When the following parameters are changed during the execution of this smoothing function, the smoothing data previously obtained is initialized and the execution of the smoothing function is started anew according to the set time.

- Measuring function
- Measurement range
- INT TIME parameter
- SM TIME parameter

[Setting Method]

The following describes the setting of the SMOOTH FUNCTION ON/OFF.

- SMOOTH FUNCTION ON/OFF setting

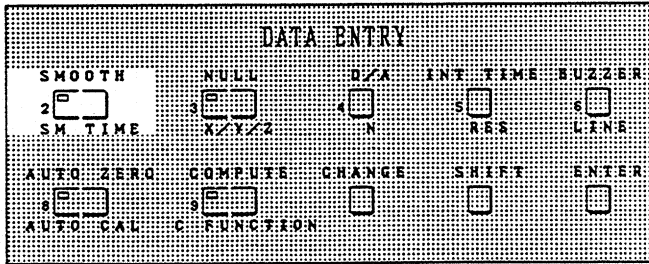

The SMOOTH FUNCTION is turned ON/OFF using the SMOOTH key.

Each time the SMOOTH key is pressed, the lamp in the key is lighted and extinguished alternately. The SMOOTH FUNCTION is ON when the lamp is lighted and OFF when the lamp is extinguished.

The setting of the SMOOTH FUNCTION ON/OFF is completed when the lamp is lighted or extinguished according to the status to be set.

However, the lamp keeps blinking until the smoothing reaches the specified time.

#### 2.7.16 SM TIME: Smoothing Time

[Functional Description]

The SM TIME parameter is used to set the number of smoothing times.

For the smoothing function, refer to parameter SMOOTH. The possible range is from 2 to 100, expressed as an integer.

[Setting Method]

The following describes the setting of the number of smoothing times.

- Parameter SM TIME Setting

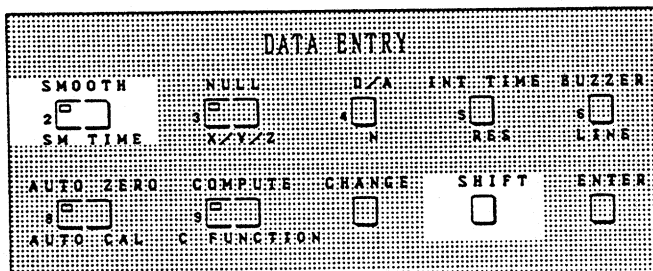

R6561  
DIGITAL MULTIMETER  
OPERATION MANUAL

2.7 Description and Setting  
Method of Parameters

- ① Press the SHIFT key.
- ② Press the SM TIME key.

The display block displays the 'previous set value of the number of smoothing times.

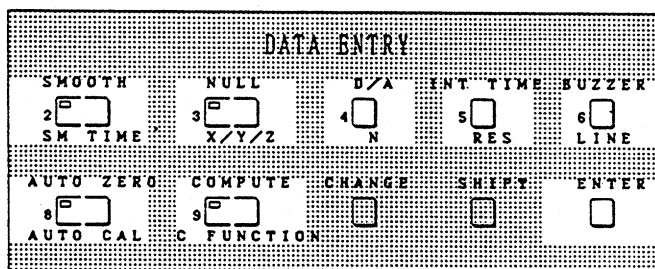
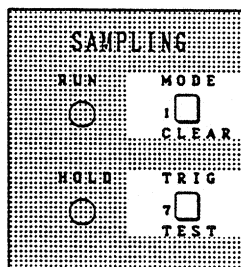
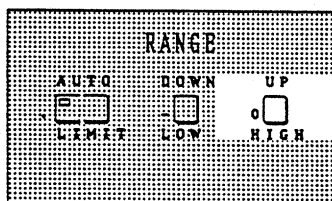
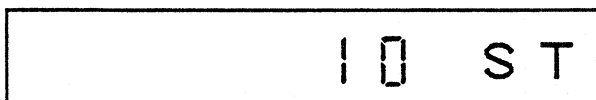

- Smoothing Time Setting

- ③ The smoothing time is set using numeric keys 0 to 9.
- When the SM TIME is set, 0 to 9 function as numeric keys.

The display block displays the set value.

(Example) When set to 12

Press 1 2 .

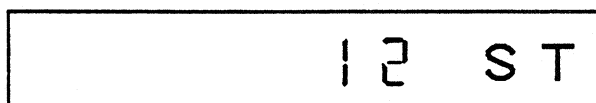

- End of Smoothing Time Setting

④ Press the ENTER key.

The smoothing time displayed in the displayed block is stored in memory.

This completes the setting of the smoothing time.

#### 2.7.17 NULL

[Functional Description]

The NULL parameter is used to set whether or not the offset including computation is executed.

When the NULL key is pressed, the lamp in the key lights and the NULL function is in ON status.

The measured object connected to the input terminal when the NULL key is pressed is measured and this measured value is made the NULL value. (The measurement is executed from the measurement range of the currently set function to the maximum range.) In the subsequent measurement, the value obtained by extracting the NULL value from the measured value becomes the result of measurement.

When the NULL key is pressed again, the NULL function goes OFF in all ranges.

**Note1:** The AUTO RANGE function of this equipment is executed for measured values, but for the result of NULL and smoothing computation. Consequently, it is possible that OVER is displayed in the display block, even though the measurement is not made in the maximum range using the AUTO RANGE function.

**Note2:** The NULL function goes OFF when the measuring function is changed.

**Note3:** The correction range is less than  $\pm 1\%$  of the full scale value of each range. If the measured value exceeds the correction range when the NULL function is set to OFF, an error results.

[Setting Method]

The following describes the setting of the NULL FUNCTION ON/OFF.

- NULL FUNCTION ON/OFF Setting

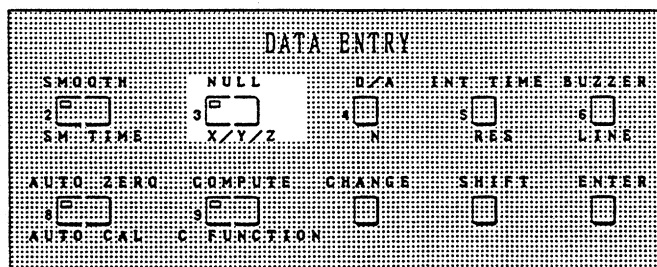

The NULL function is turned ON/OFF using the NULL key.

The NULL computation is executed when the lamp in the NULL key is in lighted.

2.7.18 TEST

[Functional Description]

The TEST parameter is used to set whether or not the self test is executed.

[Setting Method]

The following describes the setting of the self test.

- Self Test Execution

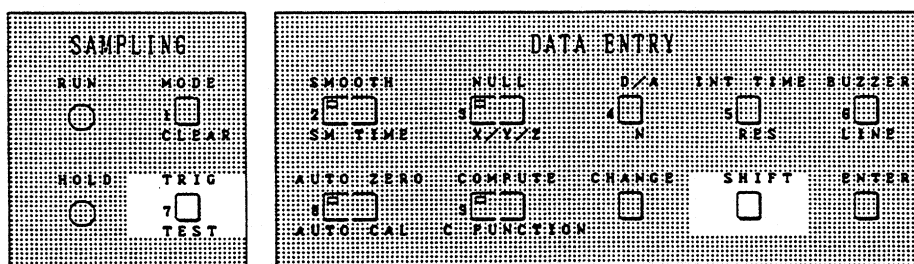

- ① Press the SHIFT key.
- ② Press the TEST key.

The self test is executed.

Check that each test item is displayed in the following order.

R6561  
DIGITAL MULTIMETER  
OPERATION MANUAL

2.7 Description and Setting  
Method of Parameters

- (1) All displays blink five times at an interval of one second and the buzzer is activated at the same interval as the blinking.

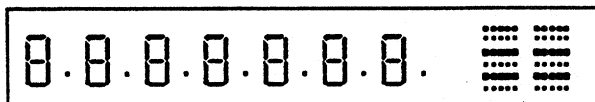

- (2) The software revision is displayed.

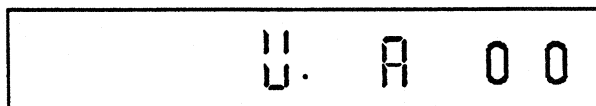

- (3) The currently set power supply frequency is displayed.

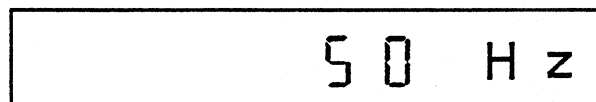

- (4) The GPIB address of R6561 is displayed.

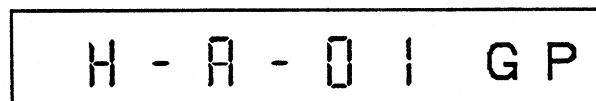

- (5) The following display is made when the check sum of the program ROM is normal.

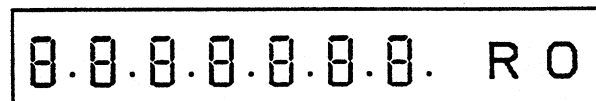

- (6) The following display is made when the check sum of the correction data saved in R6561 is normal.

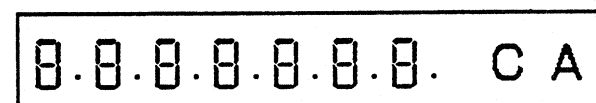

- (7) The following display is made when the result of the READ/WRITE test of RAM is normal.

0.0.0.0.0.0.0. RA

- (8) The following display is made when the test result of the analog block is normal.

0.0.0.0.0.0.0. AD

- (9) The following display is made when the AUTO CALIBRATION function is executed.

A. CAL

- (10) All displays go OFF.

R6561  
DIGITAL MULTIMETER  
OPERATION MANUAL

2.8 Basic Operating Method

---

2.8 Basic Operating Method

This section describes the operating method of the DC voltage measurement, low voltage DC measurement, and resistance measurement which constitute the basic measuring function of this equipment.

2.8.1 Basic Operation

- (1) Check that the supply voltage in use is the same as the voltage indicated with the supply voltage marking on the rear panel.
- (2) When the POWER switch is set to ON, the self diagnostic function is automatically executed.

When this equipment is normal, the lamps on the panel surface are all lighted while the self diagnostic function is executed. (See 2.7.18, TEST Function.)

When an error occurs, an error message corresponding to its content is displayed in the display block. (See 5.2, Error Message.)

Since the software revision of this equipment, the currently set power supply frequency, and GPIB address are displayed in succession at intervals of one second. Check that they meet the actual use conditions.

- (3) When the execution of self diagnostic function ends and no error is detected, the equipment is set to the operating condition when the POWER switch was set to OFF previously. (However, the COMPUTE, NULL, and SMOOTH functions are set to OFF simultaneously with the power OFF.)
- (4) When the execution of the self diagnostic function ends, check that the setting condition of each parameter meets the actual use conditions.

First check the setting status of FUNCTION, RANGE, and SAMPLING which are basic measurement parameters.

Next, check the setting condition of parameter AUTO CAL, AUTO ZERO, INT TIME, RES, and NULL.

CAUTION

Under environmental conditions in which the temperature changes are greater, reduce the AUTO CAL interval of the AUTO CAL parameter.



R6561  
DIGITAL MULTIMETER  
OPERATION MANUAL

2.8 Basic Operating Method

2.8.2 DC Voltage Measurement

(1) Input Impedance

The input impedance changes according to the range as shown in the table below:

Range	1000mV	10V	100V	500V
Input impedance	More than $10^{10} \Omega$		$10M\Omega \pm 0.5\%$	

(2) Input Cable

Connect the input cable (MI-37\*) supplied with this equipment to the input terminal for measuring the DC voltage. See the figure below:

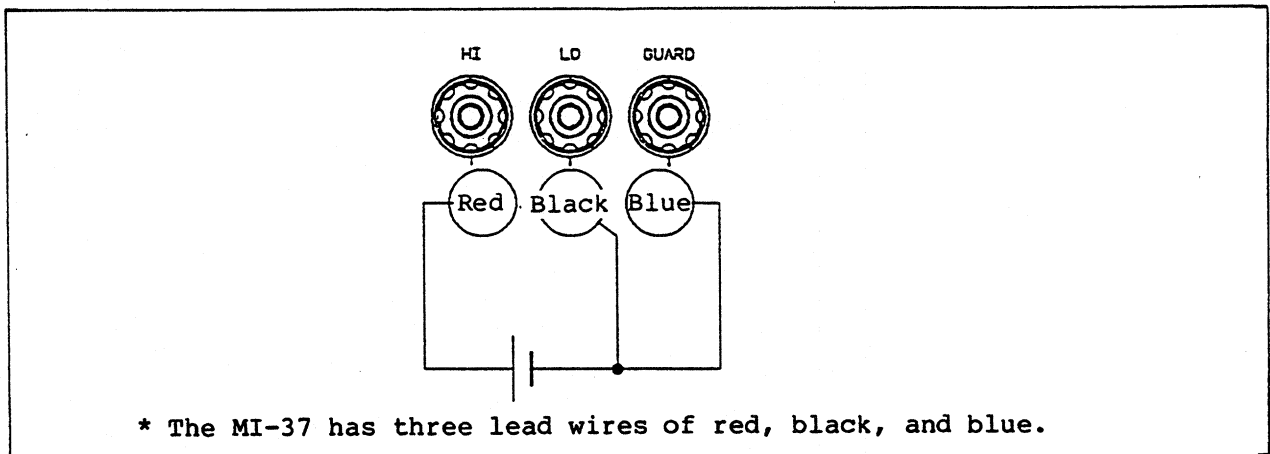

Figure 2 - 2 DC Voltage Measuring Input Cable Connection Diagram

(3) Maximum Input Voltage

The maximum input voltage is shown in the table below. Strict care should be taken not to exceed this voltage in any case.

Voltage applying terminal	Maximum input voltage
Between HI and LO terminals	$\pm 600V$ peak continuous
Between GUARD and chassis	$\pm 500V$ peak continuous
Between GUARD and LO terminals	$\pm 50V$ peak continuous

R6561  
DIGITAL MULTIMETER  
OPERATION MANUAL

2.8 Basic Operating Method

- (4) When the noise in the measured signal is high, the read error is lessened by the following method:

Since the integrate time (INT TIME) is made a multiple of power supply frequency, it has a noise eliminating effect for the power supply frequency noise. Also, even the noise of lower frequency component contained in the measured voltage is averaged by setting a longer integrate time. This enables a more stable measurement.

Note: The integrate time (INT TIME) is set to 5 PLC when the system is initialized.

See Section 2.7 for the setting method for each parameter.

2.8.3 Low Voltage DC Measurement

- (1) Input Impedance

The input impedance in each range is shown in the table below:

Range	1000 $\mu$ V	10mV	100mV	1000mV	10V
Input impedance	More than $10^8 \Omega$		More than $10^9 \Omega$	More than $10^{10} \Omega$	

- (2) Input Cable

Connect the input cable (A01020) supplied together with this equipment to the input connector.

A red, black, or blue clip is provided on the tips of these three input cables. The red is the HI terminal, the black is the LO terminal, and the blue is the GUARD terminal.

Since one side only (marked with an arrow) of the clips for the input HI and LO terminals is used for voltage measurement and the other side is kept open in the measurement of the low voltage DC, care should be taken that the arrow side contacts the measured object in the voltage measurement.

R6561  
DIGITAL MULTIMETER  
OPERATION MANUAL

2.8 Basic Operating Method

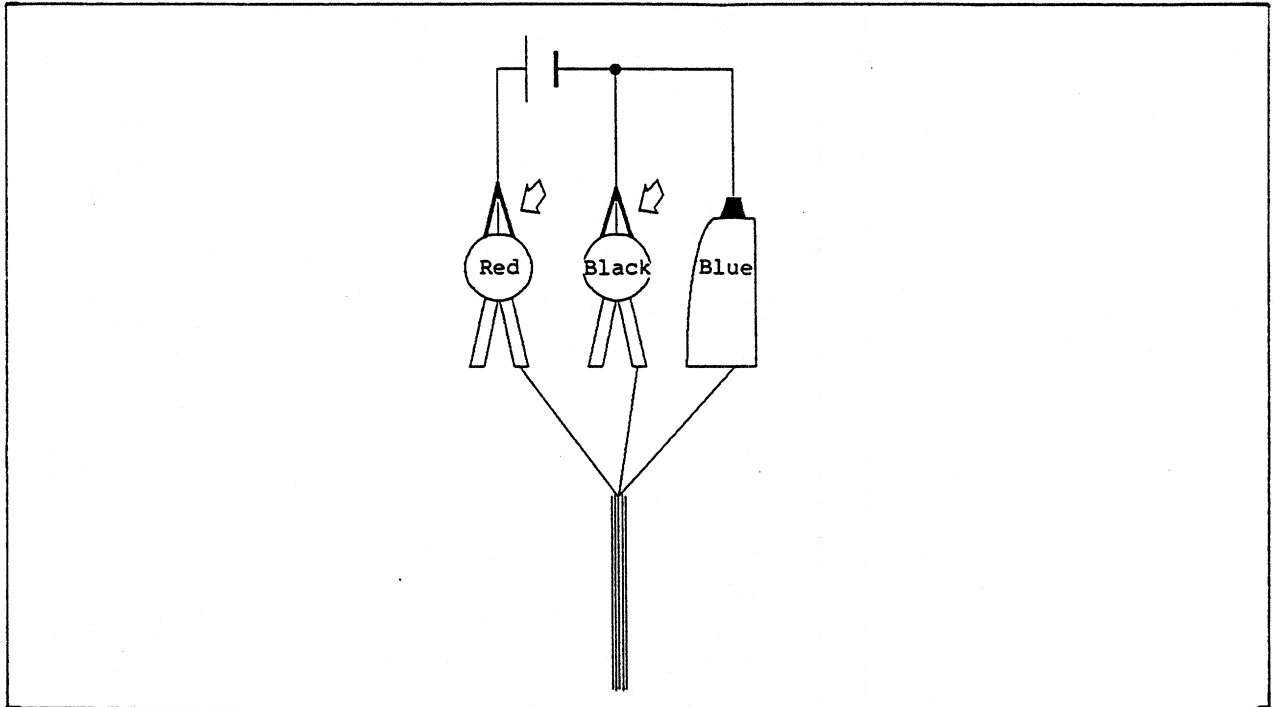

Figure 2 - 3 Low Voltage DC Measuring Input Cable Connection Diagram

- (3) The maximum input voltage is as shown in the table below. Care should be taken not to exceed this voltage in any case.

Voltage applying terminal	Maximum input voltage
Between HI and LO terminals	$\pm 30V$ peak
Between GUARD and chassis	$\pm 500V$ peak
Between GUARD and LO terminal	$\pm 50V$ peak

R6561  
DIGITAL MULTIMETER  
OPERATION MANUAL

2.8 Basic Operating Method

- (4) The integrate time (INT TIME) can be set to 5 PLC to 100 PLC. (Do not set it to 1 PLC.)

CAUTION

The 1000 $\mu$ V range (displayed in 5-1/2 digit) and 10mV range (displayed in 6-1/2 digit) have a resolution of 10nV/digit.

It is therefore necessary to take particular care of the thermoelectromotive force when the input voltage is measured.

When a temperature difference occurs between the connected parts of signal lines from the clip of the terminal of a measured signal to the input section of this equipment, a thermocouple effect occurs causing a thermoelectromotive force of several  $\mu$ V/ $^{\circ}$ C to 10 $\mu$ V/ $^{\circ}$ C. This thermoelectromotive force is added for each connecting part and appears as the drift of a zero point, causing a large error in the total measurement. To avoid this, care should be taken with the following points:

1. Important points with respect to the connection between a measured terminal and input cable
  - Do not measure the voltage when the tip of the input cable is touched by hand.
  - Read the measured value after the temperature is balanced.
  - Do not take measurements in a location where the air is being circulated.
  
2. Important points with respect to environmental conditions for this equipment
  - Allow adequate preheating time (approx. one hour) after the power is turned ON.
  - When measurements are made after moving to a location where the ambient temperature differs considerably from the previous location allow a sufficient warm-up period.
  - Avoid installing this equipment in a location where the air is being circulated.

R6561  
DIGITAL MULTIMETER  
OPERATION MANUAL

2.8 Basic Operating Method

2.8.4 Resistance Measurement

- (1) In resistance measurement, it is possible to select the HI-P (High Power) mode and LO-P (Low Power) mode. Each current value is shown in the table below:

Range		100mΩ	1000mΩ	10Ω	100Ω	1000Ω	10kΩ
Measurement current	HI-P mode	—	10mA	10mA	1mA	100μA	10μA
	LO-P mode	10mA	1mA	100μA	10μA	1μA	—

- (2) Voltage between Open Terminals

The voltage between open current source terminals in the resistance measurement is as shown in the table below:

Range		100mΩ	1000mΩ	10Ω	100Ω	1000Ω	10kΩ
Voltage between open terminals	HI-P mode	—	1V	1V	1V	1V	1V
	LO-P mode	20mV	20mV	20mV	20mV	20mV	—

- (3) Maximum Input Voltage

The maximum input voltage is as shown in the table below. Care should be taken not to exceed this voltage in any case.

Voltage applying terminal	Maximum input voltage
Between measuring terminals	±30V peak
Between GUARD and chassis	±500V peak
Between GUARD and LO terminal	±50V peak

- (4) Input Cable

Connect the input cable (A01004) supplied together with this equipment to the input connector.

A red, black, or blue clip is attached to the tips of each of the three input cables. The red is the HI terminal, the black the LO terminal, and the blue the GUARD terminal.

In this resistance measurement, one side of the clips for the input HI and LO terminals is made the current source terminal and the other side the voltage measurement terminal.

R6561  
DIGITAL MULTIMETER  
OPERATION MANUAL

2.8 Basic Operating Method

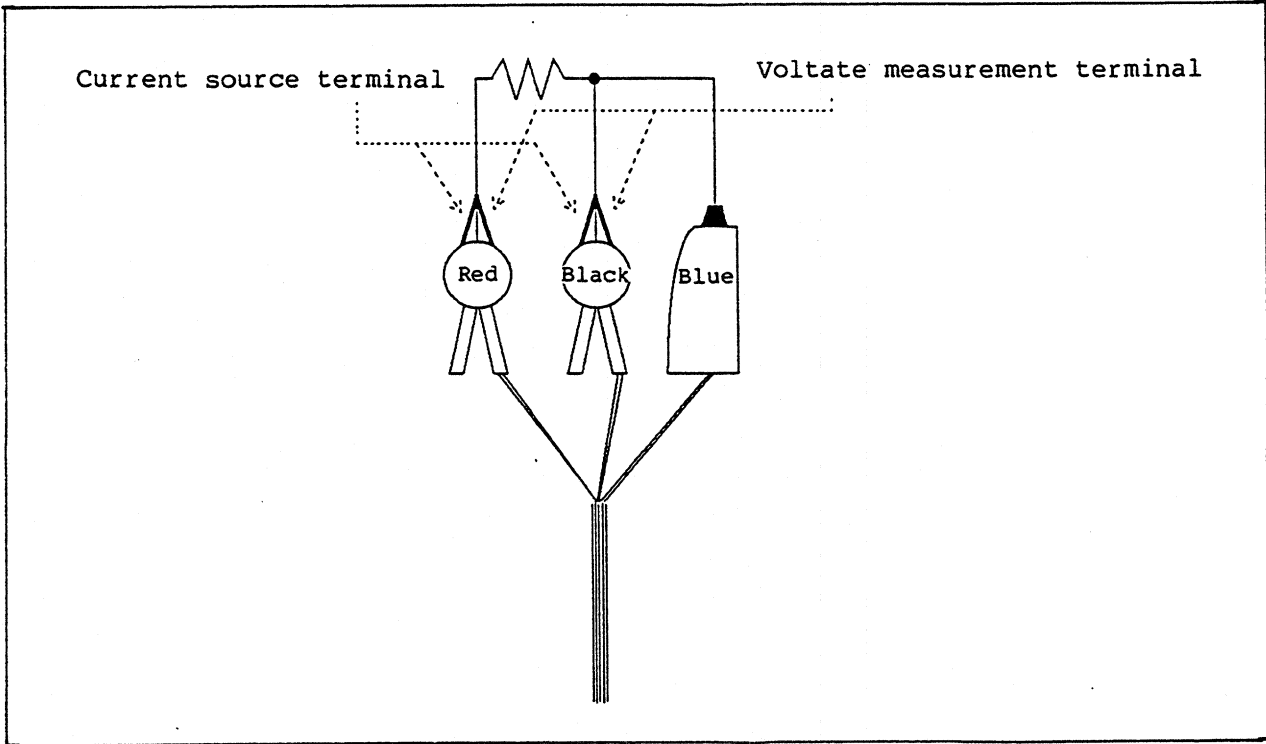

Figure 2 - 4 Resistance Measurement Input Cables Connection Diagram

- (5) The possible integrate time (INT TIME) for setting is 5 PLC to 100 PLC. Do not set it to 1 PLC.

R6561  
DIGITAL MULTIMETER  
OPERATION MANUAL

3.1 General Description

---

3. OPERATING METHOD - 2 (COMPUTING FUNCTION)

3.1 General Description

The operating function consists of two parts, the primary computation and secondary computation.

This section gives only the names of the primary and secondary computing functions. Detailed descriptions will be given in the next and subsequent sections.

(1) Primary Computing Function

- ① Scaling
- ② % deviation
- ③ Delta
- ④ Multiply
- ⑤ Decibel conversion
- ⑥ RMS value
- ⑦ dBm conversion
- ⑧ Resistance value temperature correction

(2) Secondary Computing Function

- ① Comparator 1
- ② Comparator 2
- ③ Statistical processing

(3) How to Read the Functional Description of Each Computing Function

- ① Symbols used in each computing

\*: Multiply  
 $\Sigma$ : Cumulative addition  
/: Division

- ② This is an example of a case where the computing result is displayed in 6-1/2 digit.

The symbol "E" indicates the exponent is omitted in the display.

Before reading the functional description of each computing result, be sure to read through the description of the setting of constants and the display of computing results in the next section.

R6561  
DIGITAL MULTIMETER  
OPERATION MANUAL

3.2 Setting of Constants and  
Display of Computing Results

---

3.2 Setting of Constants and Display of Computing Results

(1) Setting of Constants

A constant is set as a basic unit in principle.

Unless otherwise specified, the real number constant is set in the binary coded decimal (BCD) notation of floating point number. The possible range is as follows:

-1999999 E9 to 1999999 E9 ( $\pm 1.9.9.9.9.9.9. \pm E9$ )

The mantissa only is set when the exponent is 0, and an integer can be input when the exponent is an integer.

For constants X, Y, Z, HIGH1, HIGH2, LOW1, LOW2, and LIMIT, the previous measurement values or computing results can be set using the MD key.

Note: When the function range is changed during an operation from the previous measurement to the setting of a constant with the MD key, the value obtained cannot be guaranteed.

(2) Display of Computing Result

① The computing result is rounded according to the output digit mode, and each output digit only is displayed.

② When a measured value exceeds the range, OL is displayed.

The unit display block displays the unit corresponding to each computing result.

③ For the display format of the computing result, see each computing item.

CAUTION

1. Basic Unit

Voltage measurement : V  
Resistance measurement:  $\Omega$

2. When the following operations are made during the execution of a computation, the COMPUTE key is automatically set to OFF.

Change in computing mode  
Change in the setting of a constant



### 3.3 SCALING

#### [Object Data]

The scaling can be computed for the following data:

- Measurement data

#### [Computation Expression]

$$R = \frac{D - Y}{X} * Z$$

R: Result of computation  
D: Object data  
X: Constant (a set value)  
Y: Constant (a set value)  
Z: Constant (a set value)

#### [Set Range of Constant]

X : ±1999999 E-9 to ±1999999 E+9 (Except 0)  
Y, Z: ±1999999 E-9 to ±1999999 E+9 (Except 0)

#### [Display of Computing Results]

The system judges effective characters of measured values and displays their computing results in the following priority:

(1) R: -1999999 to 1999999

Displays the result in the measurement unit.

(2) R: ±1999999 E-19 to ±1999999 E+19

Displays the result in the basic unit of each measuring function. However, the exponent is displayed if it exists, and not the basic unit.

(3) Others

A computation error results when the exponent exceeds E+19, and 0. E-19 is displayed when the exponent exceeds E-19.

#### [Example of Use]

The output signals from the pressure, temperature, and distortion sensors etc., and transducers are measured and the results can be read directly by converting them to a unit corresponding to the respective physical quantity.

R6561  
DIGITAL MULTIMETER  
OPERATION MANUAL

3.3 SCALING

- (1) When set to  $Y = 0$  and  $X = 1$ , a computation of  $D/X$  is available to obtain the result by dividing the data by an arbitrary value ( $X$ ).

It is also possible, using the above computation, to read the value of current flowing in a resistor directly by measuring the drop ( $D$ ) in the voltage applied to both ends of the resistor ( $X$ ).

- (2) When set to  $X = Z = 1$ , the computation becomes  $R = D - Y$  which is available for the removal of an offset value, etc.
- (3) By incorporating a sensor output value when the sensor input is assumed to be 0 (zero) into  $Y$ , and also the span value between the zero and full scale of the sensor input to  $X$ , it is possible to yield  $Z = 1$  to obtain the offset value and scaling value corrected in inclination.

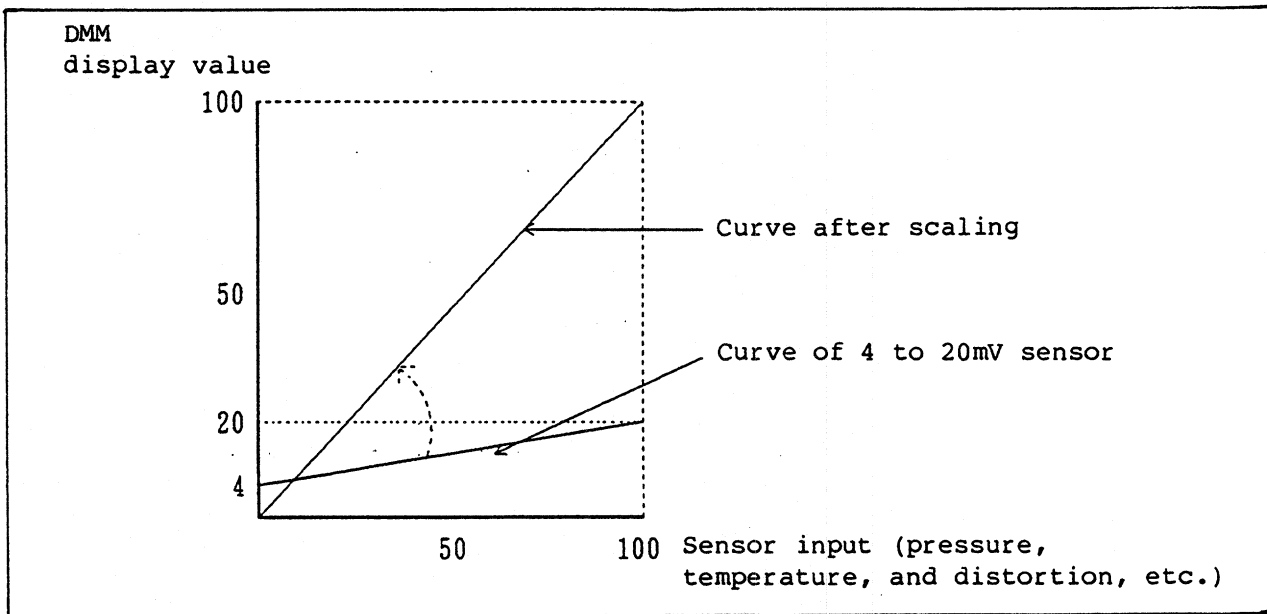

Figure 3 - 1 Scaling for Direct Reading of 4 to 20mV Sensor/Transmitter

[Scaling Computation Expression]

$$R = \frac{D - Y}{X} * Z$$

R: Computing result  
D: Object data  
X: 0.16  
Y: 4  
Z: 1

$$R = \frac{D - 4}{0.16}$$

### 3.4 %DEVIATION

[Object Data]

The % deviation can be computed for the following data:

- Measurement data

[Computation Expression]

$$R = \frac{D - Y}{X} * 100$$

R: Computing result

D: Object data

X: Constant (set value)

[Set Range of Constant]

X: ±1999999 E-9 to ±1999999 E+9 (Except 0)

[Display of Computing Results]

R : -1999.999 to 1999.999

Unit: Displays a percentage (%).

Exceeding the output range causes a computation error.

[Example of Use]

This can be used for the application of selection and rank sorting of a component part, e.g., resistor, etc.

By setting a reference value to X, the percentage (%) deviation of object data D to X can be obtained.

R6561  
DIGITAL MULTIMETER  
OPERATION MANUAL

3.4 %DEVIATION

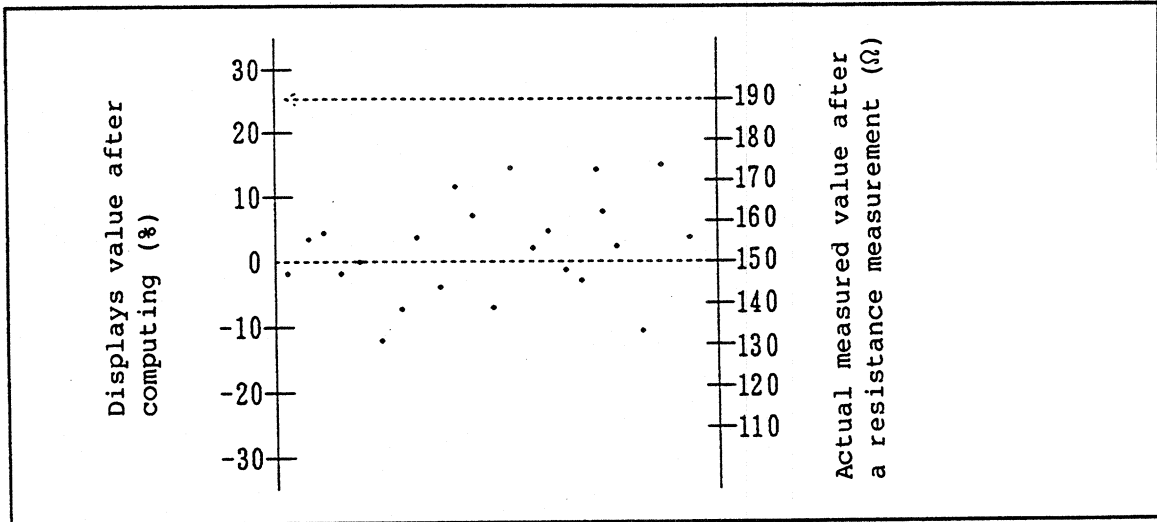

Figure 3 - 2 Example of Application to the Computation of % Deviation (Measurement of Deviation in Resistance Value when  $X = 150\Omega$ )

### 3.5 DELTA

[Object Data]

The delta can be computed for the following data:

- Measurement data

[Computation Expression]

$$R = D_t - D_{t-1}$$

R : Computing result

$D_t$  : Measured value at time t

$D_{t-1}$  : Measured value before 1 sampling of time t

[Display of Computing Result]

R: -1999999 to 1999999

Displays the result of computation with the measurement unit in the larger range for this measurement and the previous measurement. Exceeding the output range causes a computing error.

[Notes in Computing Execution]

- ① The first time is displayed DELTA computing is set the object delta. For the second and subsequent times, the computing results are displayed.
- ② When the measuring function is changed during the execution of a computation, the data in the previous function is initialized and the computation is continued anew.

[Example of Use]

Differential values can be obtained in a computation to display the variable component of the input signal for each sampling interval. This computation is effective when the input signal has been entered in its stabilized state in case the variable component of input becomes lower than the specified value by monitoring the varied component of temperature and pressure, etc.

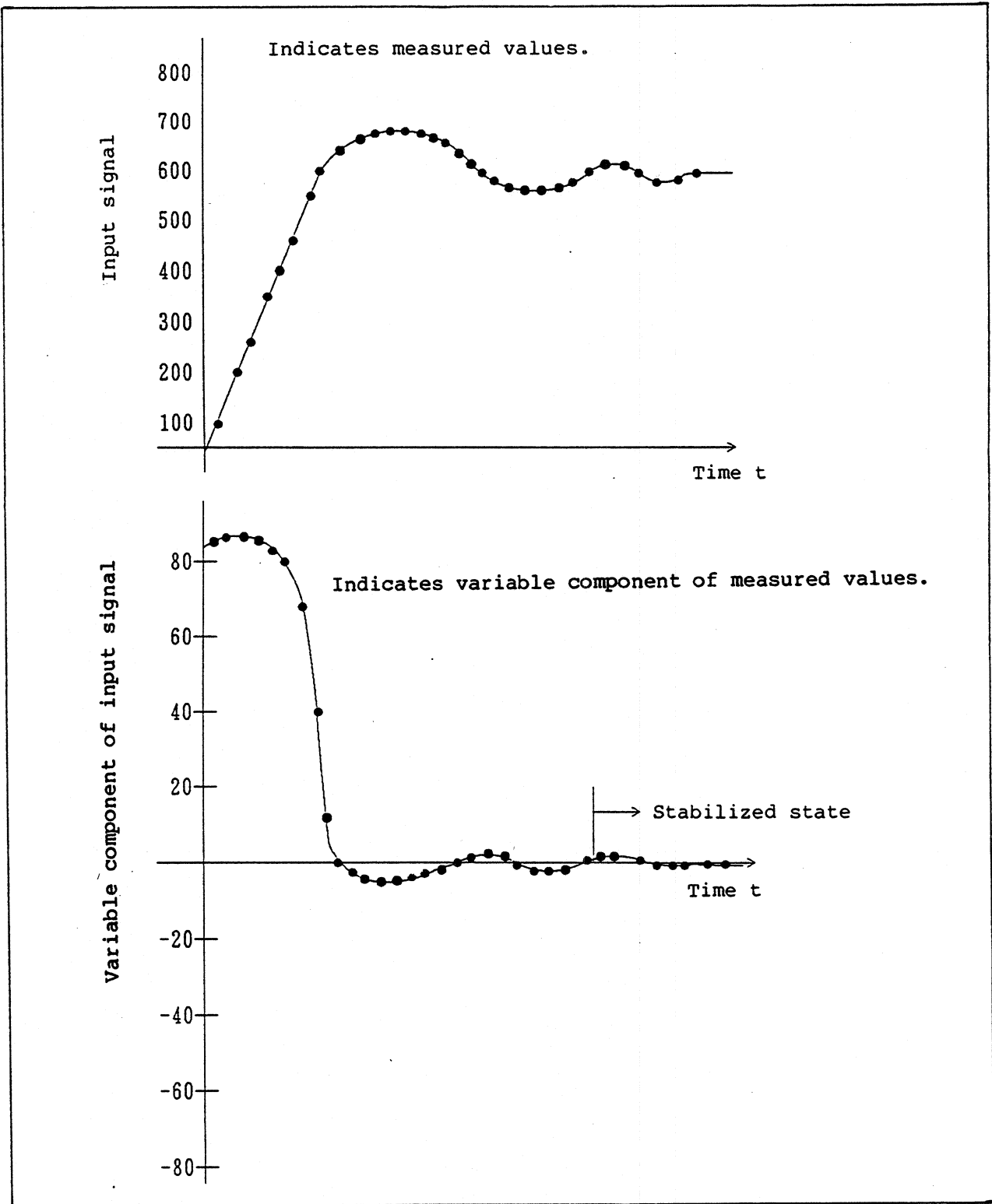

Figure 3 - 3 Application Example of DELTA

### 3.6 MULTIPLY

[Object Data]

The MULTIPLY function can be computed for the following data:

- Measurement data

[Computation Expression]

$$R = D_t * D_{t-1}$$

R : Computing result

$D_t$  : Measured value at time t

$D_{t-1}$ : Measured value before 1 sampling at time t

[Display of Computing Result]

R:  $\pm 1999999 E-19$  to  $\pm 1999999 E+19$

No unit

When the exponent exceeds E+19, a computation error occurs.

When the exponent exceeds E-19, 0. E-19 is displayed in the display block.

[Note in Computing Execution]

- (1) The first result obtained when multiply computing is set displays measured values. For the second and subsequent time the computing results are displayed.
- (2) Even when the measuring function is changed during the execution of a multiply computation, the computation is continued as is. (The product of V and  $\Omega$  can be obtained from this computation.)

3.7 dB (Decibel Conversion)

[Object Data]

The decibel conversion can be computed for the following data:

- Measurement data

[Computation Expression]

$$R = 20 * Y * \log_{10} \left| \frac{D}{X} \right|$$

R: Computing result

D: Object data

X: Constant (a set value)

Y: Constant (a set value)

[Set Range of Constant]

X:  $\pm 1999999 \text{ E-9}$  to  $\pm 1999999 \text{ E+9}$  (Except 0)

Y:  $\pm 1999999 \text{ E-9}$  to  $\pm 1999999 \text{ E+9}$

[Display of Computing Results]

R : -199.999 to 1999.999

Unit: Displays dB.

When the computing result exceeds the output range a computation error occurs.

[Note in Execution of Computation]

When the object data D becomes 0 (zero) during the execution of decibel computing, a computation error occurs.

[Example of Use]

This dB conversion is especially effective when used to obtain voltage gain.

When the input signal voltage value is set to  $Y = 1$ , X and the output voltage is measured, the voltage gain can be obtained according to the following equation:

$$Gv = 20 \log_{10} \left| \frac{D}{X} \right|$$



### 3.8 RMS Value (Effective Value)

[Object Data]

The effective value can be computed for the following data:

- Measurement Data

[Computation Expression]

$$R = \sqrt{\frac{1}{X} \sum_{k=1}^X Dk^2}$$

R : Computing result

Dk: Object data

X : Constant (a set value)

K : A variable which takes an integer from 1 to X

[Setting Range of Constant]

X: Integer from 2 to 10000

(When input with a real number, the computation is made by rounding it to an integer.)

[Display of Computing Result]

The system judges effective numeric characters of measured values in the maximum range of X times the measurement, and displays the computing results in the following priority:

(1) R: 0 to 1999999

Displays this value with the measurement unit in the maximum range of X times the measurement.

(2) R: 1999999 E-9 to 1999999 E+19

Displays this value with the basic unit of each measuring function.

However, the exponent is displayed when it exits, but the basic unit.

(3) When the exponent exceeds E+19 in the basic unit, a computing error occurs. When it exceeds E-19, 0. E-19 is displayed in the display block.

R6561  
DIGITAL MULTIMETER  
OPERATION MANUAL

3.8 RMS Value (Effective Value)

---

[Notes in Computing Execution]

- (1) When RMS computing is set, the RMS lamp under the display block lights and all indicator lamps on the display block are extinguished until the first computing result is obtained. When the measurement reaches the number of measuring times set by constant X, the computing result is displayed in the display block.
- (2) The data becomes invalid when it exceeds the set range during the execution of RMS computing and is not included in the number of measuring times.
- (3) When the measuring function is changed during the execution of RMS computing, the data in the previous function is initialized and the computation is continued anew.

[Note in Operation]

When the  $\text{H0}$  (HOME) key is pressed during the execution of RMS computing, the RMS computing results up to the current number of measuring times is displayed in the display block and the computation is continued anew.

R6561  
DIGITAL MULTIMETER  
OPERATION MANUAL

3.9 dBm (dBm Conversion)

---

3.9 dBm (dBm Conversion)

[Object Data]

The dBm conversion can be computed for the following data:

- Measurement Data

[Computation Expression]

$$R = 10 * \log_{10} \frac{D^2}{X \cdot 1mW}$$

R: Computing result

D: Object data

X: Reference resistance value ( $\Omega$ )

[Set Range of Constant]

X: 0 to 19999999E9 (Except 0)

[Display of Computing Result]

R : -1999.999 to 1999.999

Unit: dBm

This unit is displayed as Bm in the display block.

Exceeding the output range causes a computation error.

[Example of Use]

This dBm conversion is effective in the computation of power gain.

If the resistance value when voltage D is measured is set to X, the power gain can be obtained according to the following equation:

$$G_w = 10 * \log_{10} \frac{D^2}{X \cdot 1mW}$$

[Note in Operation]

The dBm computation is effective in the voltage measurement only.

When the measuring function is changed to any function other than voltage measurement during the execution of the dBm computation, the COMPUTE key turns OFF.

R6561  
DIGITAL MULTIMETER  
OPERATION MANUAL

3.10 Resistance Value Temperature  
Correction (at 20°C)

---

3.10 Resistance Value Temperature Correction (at 20°C)

[Object Data]

The resistance value temperature correction can be computed for the following data:

- Measurement Data

[Computation Expression]

$$R_{20} = \frac{R_x}{1 + 0.00393 (X-20)} * \frac{1000}{Y}$$

R20: Resistance value of a cable converted to 20°C (per 1km)

Rx : Resistance value measured at X°C (Ω)

X : Room temperature when measured (°C)

Y : Length of measured cable (m)

[Set Range of Constant]

X: Room temperature when measured (°C)  
±1999999 E-9 to ±1999999 E+9

Y: Length of cable (m)  
0 to 1999999E9 (Except 0)

[Display of Computing Result]

The system judges effective numeric characters of measured values and displays the computing results in the following priority.

(1) R: -1999999 to 1999999

Displays in a measurement unit.

(2) R: ±1999999 E-19 to ±1999999 E+19

Displays in the basic unit (Ω).

The exponent is displayed when it exists, and not the basic unit.

(3) When the exponent exceeds E+9 in the basic unit a computation error occurs. When the exponent exceeds E-9 in the basic unit, 0. E-9 is displayed.

[Example of Use]

This computation expression converts the resistance value of an annealed copper wire (IEC standard annealed copper wire) measured at X°C into the value measured at 20°C. This expression is used among cable manufacturers, etc.

R6561  
DIGITAL MULTIMETER  
OPERATION MANUAL

3.10 Resistance Value Temperature  
Correction (at 20°C)

---

[Note in Operation]

The resistance value temperature correction computing is effective for the resistance measurement only.

When the measuring function is changed to a function other than the resistance value measurement during the execution of a resistance value temperature correction computing, the COMPUTE key turns OFF.

R6561  
DIGITAL MULTIMETER  
OPERATION MANUAL

3.11 COMPARATOR 1

3.11 COMPARATOR 1

[Object Data]

The COMPARATOR 1 can be computed for the following data:

- Measurement data
- Data after primary computing

[Computation Expression]

Compares data D with a set value (HIGH1, HIGH2, LOW1, and LOW2), and classifies it in order of magnitude (large/small).

- R (H2) when  $HIGH\ 2 < D$
- R (H1) when  $HIGH\ 1 < D \leq HIGH\ 2$
- R (PASS) when  $LOW\ 1 \leq D \leq HIGH\ 1$
- R (L1) when  $LOW\ 2 \leq D < LOW\ 1$
- R (L2) when  $D < LOW\ 2$

- R ( ) : Computing result of each item
- D : Object data
- HIGH 1: Constant (a set value); and upper limit value 1
- HIGH 2: Constant (a set value); and upper limit value 2
- LOW 1 : Constant (a set value); and lower limit value 1
- LOW 2 : Constant (a set value); and lower limit value 2

[Set Range of Constant]

HIGH1, HIGH2, LOW1, LOW2:  $\pm 1999999\ E-9$  to  $\pm 1999999\ E+9$

Where,  $HIGH1 \leq HIGH2$   
 $LOW2 \leq LOW1$   
(or  $HIGH < LOW$ )

[Display of Computing Result]

The computing result is displayed as follows according to the classification defined as the result of the computation expression:

- The HIGH lamp lights at R (H2).
- The HIGH lamp blinks at R (H1).
- The PASS lamp lights at R (PASS).
- The LOW lamp blinks at R (L1).
- The LOW lamp lights at R (L2).

A value to be displayed in the display block is the object data obtained when the COMPARATOR1 computation is executed.

R6561  
DIGITAL MULTIMETER  
OPERATION MANUAL

3.11 COMPARATOR 1

---

[When Parameter BUZZER is Set]

(1) When parameter BUZZER is set to ON-1

The buzzer is activated at R (H2), R (H2), R (L1), and R (L2) are obtained.

(2) When parameter BUZZER is set to ON-2

The buzzer is activated at R (PASS) is obtained.

R6561  
DIGITAL MULTIMETER  
OPERATION MANUAL

3.12 COMPARATOR 2

3.12 COMPARATOR 2

[Object Data]

The COMPARATOR 2 can be computed for the following data:

- Measurement data
- Data after primary computation

[Computation Expression]

Where  $H2 = LIMIT + \%2$ ,  $H1 = LIMIT + \%1$ ,  $L1 = LIMIT - \%1$ , and  $L2 = LIMIT - \%2$ , the system compares data D with H1, H2, L1, and L2 and classifies it in the order of magnitude (large/small) between the two.

- R (H2) when  $H2 < D$
- R (H1) when  $H1 < D \leq H2$
- R (PASS) when  $L1 \leq D \leq H1$
- R (L1) when  $L2 \leq D < L1$
- R (L2) when  $D < L2$

- R ( ) : Computing result of each item
- D : Object data
- LIMIT: Constant (a set value); and reference value
- $\%1$  : Constant (a set value); and tolerance (% deviation from a reference value)
- $\%2$  : Constant (a set value); and tolerance (% deviation from a reference value)

[Set Range of Constant]

- LIMIT : Reference value  
 $\pm 1999999 E-9$  to  $\pm 1999999 E+9$  (Except 0)
- $\%1, \%2$ : Tolerance (Unit: %)  
0.000 to 100.0 (Real number less than four digits)  
Where,  $\%1 \leq \%2$

[Display of Computing Result]

The computing result is displayed as follows according to the classification defined as the result of the computation expression:

- The HIGH lamp lights at R (H2).
- The HIGH lamp blinks at R (H1).
- The PASS lamp lights at R (PASS).
- The LOW lamp blinks at R (L1).
- The LOW lamp rights at R (L2).

Incidentally, a value to be displayed in the display block is the value obtained by converting the object data into the % deviation for a reference value.



R6561  
DIGITAL MULTIMETER  
OPERATION MANUAL

3.12 COMPARATOR 2

---

[When Parameter BUZZER is Set]

(1) When parameter BUZZER is set to ON-1

The buzzer is activated at R (H2), R (H1), R (L1), and R (L2).

(2) When parameter BUZZER is set to ON-2

The buzzer is activated at R (PASS).

R6561  
DIGITAL MULTIMETER  
OPERATION MANUAL

3.13 STATISTICS (Statistical Processing)

---

3.13 STATISTICS (Statistical Processing)

[Object Data]

The STATISTICS can be computed for the following data:

- Measurement data
- Data after the primary computing

[Computation Expression]

The meaning of computing results and computation expression are as follows:

R(COUNT): Sample size  
R(MAX) : Maximum value  
R(MIN) : Minimum value  
R(AVE) : Average

$$R(AVE) = \frac{\sum_{k=1}^N D_k}{N}$$

R(P-P) : Width of dispersion  
R(P-P) = R(MAX) - R(MIN)  
R( ) : Standard deviation

$$R(\sigma) = \sqrt{\frac{1}{N-1} \sum_{K=1}^N (D_k - \bar{D})^2}$$

Where,

$$\bar{D} = \frac{\sum_{k=1}^N D_k}{N} = R(AVE)$$

R(UCL): Upper Control Line  
R(AVE) + 3R(σ)

R(LCL): Lower Control Line  
R(AVE) - 3R(σ)

R( ) : Computing result of each item

D<sub>k</sub> : Object data

N : Constant (a set value); and the number of data setting times

R6561  
DIGITAL MULTIMETER  
OPERATION MANUAL

3.13 STATISTICS (Statistical Processing)

---

[Set Range of Constant]

N: Number of data setting times  
Integer from 2 to 10000

[Display of Computing Result]

R(COUNT): Integer from 2 to 10000

R(MAX), R(MIN), R(AVE), R(P-P), R(UCL), R(LCL):

The output range and unit are displayed as in the computing object data. When the object data is a measured value, or when it is scaling, RMS, or resistance value temperature correction computing result, effective digits and measurement unit are judged by the object data in the maximum measuring range among N times of measurement.

R( $\sigma$ ) :  $\pm 1999 E-19$  to  $\pm 1999 E+19$

The mantissa is effective in 3.5 digits.

The unit is displayed as in the computing object data.

However, with the exception of the case where the object data is greatly dispersed, it results will generally be with the exponent and no unit is displayed.

[Operating Method]

The following is a description of how to operate the statistical computation.

A description is made by way of an example where a statistical processing is made when the sample size is assumed to be 10.

An outline of the operating procedure follows:

- I. Setting of a Sample Size (Parameter N)
- II. Setting of a Computing Function (Parameter C FUNCTION)
- III. Execution of Computing
- IV. Output of Computing Result

R6561  
DIGITAL MULTIMETER  
OPERATION MANUAL

3.13 STATISTICS (Statistical Processing)

I. Setting of Sample Size

- Setting of Parameter N

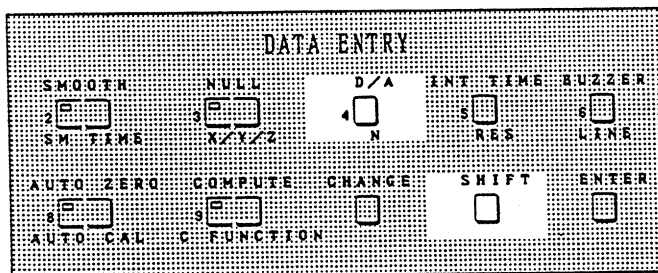

- ① Press the SHIFT key.
- ② Press the N key.

The display block displays the currently set value of constant N.

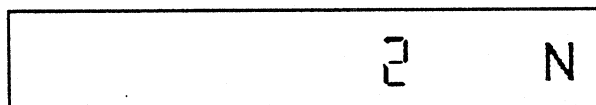

- Setting of Constant

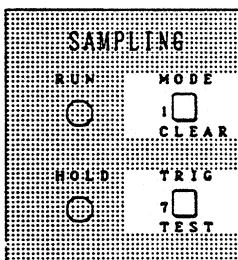
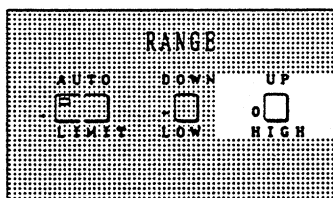

- ③ Set sample size 10 to the constant N.

Press  .

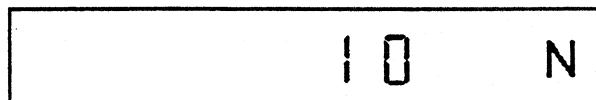

R6561  
DIGITAL MULTIMETER  
OPERATION MANUAL

3.13 STATISTICS (Statistical Processing)

- End of Setting of Constant

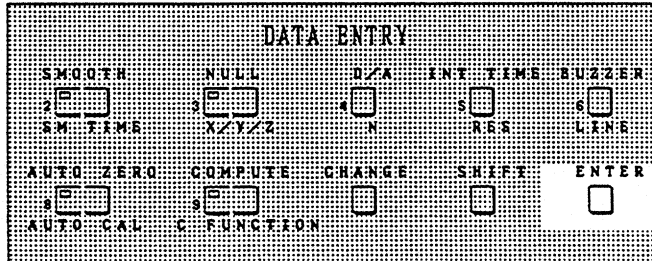

④ Press the ENTER key.

II. Setting of Computing Function

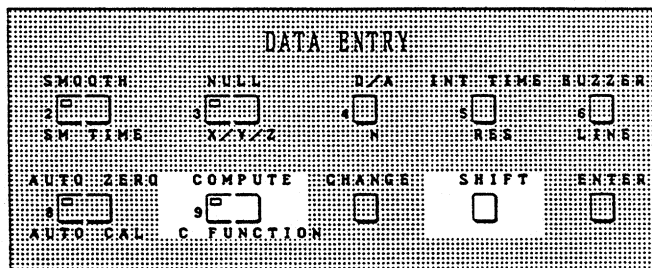

- Setting of Parameter C FUNCTION

⑤ Press the SHIFT key.

⑥ Press the C FUNCTION key.

The display block displays the current set value of the primary computation and secondary computation.

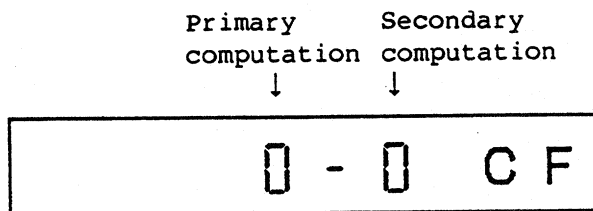

Blinking

R6561  
DIGITAL MULTIMETER  
OPERATION MANUAL

3.13 STATISTICS (Statistical Processing)

- Computing Function Section

- ⑦ To set the STATISTICS function, press the SHIFT key to display the secondary computation blink.

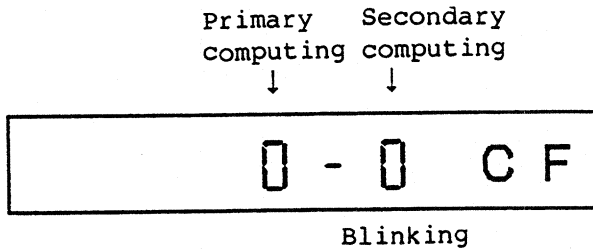

- Setting of Computing Function

- ⑧ Input STATISTICS computing function code "3".

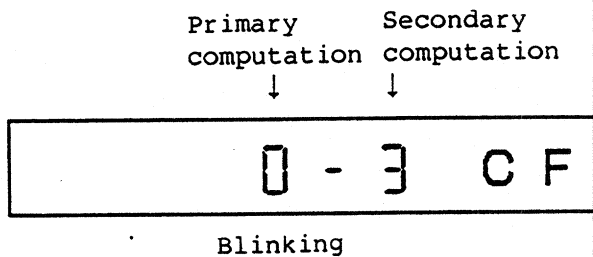

- End of Computing Function Setting

- ⑨ Press the ENTER key.

III. Execution of Computing

- Execution of Computing

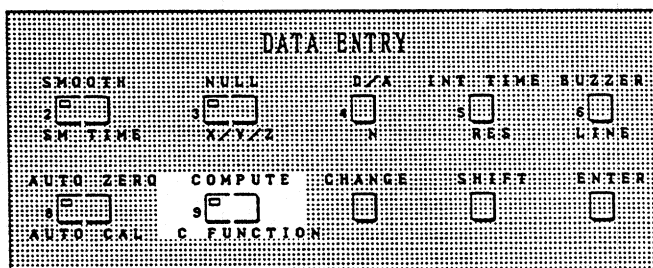

R6561  
DIGITAL MULTIMETER  
OPERATION MANUAL

3.13 STATISTICS (Statistical Processing)

- 10 Press the COMPUTE key. The computation is executed. After 10 samples have been computed the display block displays the object data.

When the computation ends, the display block indicates the output mode input waiting status.

The output mode is a means to output the computing result. Two modes are available. One is a step output mode; the other, a continuous output mode.

The output mode displayed is the previously set mode.

STAT - 0

(Stat : STATISTICS)    ↑  
                                  Output mode

[Step Output Mode]

The step output mode is a means to have computing results (eight types) output one by one. When this mode is to be selected, set "0" as the output mode.

[Continuous Output Mode]

The continuous output mode is a means to output computing results (eight types) all at once. When this mode is to be selected, set "1" as the output mode.

CAUTION

Use the step output mode just for display output, since the output object is barely visible in output only.

IV. Output of Computing Result

Two operating methods to output computing results in the step output mode and continuous output mode are described below.

R6561  
DIGITAL MULTIMETER  
OPERATION MANUAL

3.13 STATISTICS (Statistical Processing)

[Means to Output in Step Output Mode]

- Setting of Step Output Mode

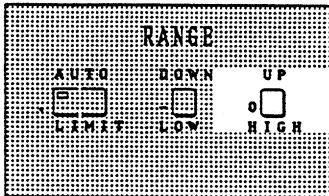

⑪ Press .

The step output mode is set.

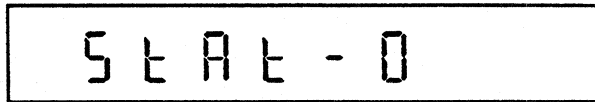

- Execution of Step Output

⑫ Press the ENTER key.

A sample size is first output.

The subsequent computing results will be output each time the SHIFT key is pressed.

Sample size

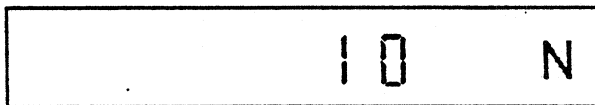

[Order of Output]

Computing results are output in the following order each time the SHIFT key is pressed:

Sample size	
Maximum value	R (MAX)
Minimum value	R (MIN)
Average	R (AVE)
Width of dispersion	R (P-P)
Sigma ( $\sigma$ )	R ( $\sigma$ )
Average + 3 sigma	R (UCL)
Average - 3 sigma	R (LCL)



R6561  
DIGITAL MULTIMETER  
OPERATION MANUAL

3.13 STATISTICS (Statistical Processing)

When the SHIFT key further pressed when the output of one cycle of computing results (eight types) ends, the display returns to the output mode set wait status (display of step ⑩ above).

- ⑬ Press the SHIFT key.

The maximum value is displayed and the MAX lamp under the display block lights.

- 6.11633 V

MAX

- ⑭ Press the SHIFT key.

The minimum value is displayed and the MIN lamp under the display block lights.

- 6.11926 V

MIN

- ⑮ Press the SHIFT key.

The average is displayed and the AVE lamp under the display block lights.

- 6.11752 V

AVG

- ⑯ Press the SHIFT key.

The width of dispersion is displayed and the MAX lamp and MIN lamp under the display block light.

0.00293 V

MAX MIN

R6561  
DIGITAL MULTIMETER  
OPERATION MANUAL

3.13 STATISTICS (Statistical Processing)

- ⑰ Press the SHIFT key.

The  $\sigma$  (sigma) is displayed and the  $\sigma$  lamp under the display block lights.

1.0 14000 - 3

$\sigma$

- ⑱ Press the SHIFT key.

The UCL is displayed and the  $\sigma$  lamp and HIGH lamp under the display block light.

- 6.11448 V

HIGH

$\sigma$

- ⑲ Press the SHIFT key.

The LCL is displayed and the  $\sigma$  lamp and LOW lamp under the display block light.

- 6.12056 V

LOW

$\sigma$

- ⑳ Press the SHIFT key.

The output of one cycle (eight types) of computing results ended in step ⑲ above.

When this step is executed, the display block returns to the output mode set wait status (the display of step ⑩ above).

SETE - 0

R6561  
DIGITAL MULTIMETER  
OPERATION MANUAL

3.13 STATISTICS (Statistical Processing)

- End of Step Output Mode

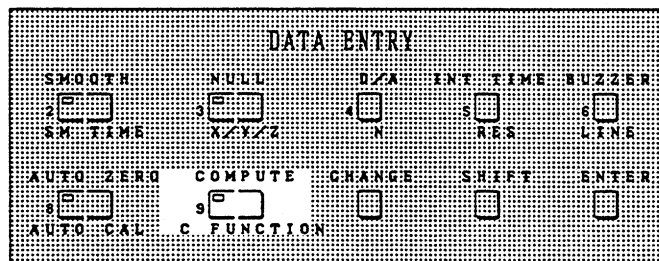

- ② Press the COMPUTE key.

The COMPUTE lamp goes off, the step output mode ends, and the display returns to the measurement mode.

[Means to Output Computing Results in Continuous Output Mode]

- Setting of Continuous Output Mode

- ① Press .

The continuous output mode is set to the output mode.

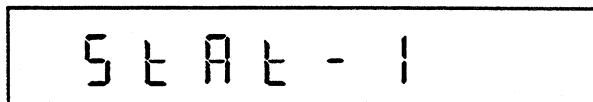

- Execution of Continuous Output

- ⑫ Press the ENTER key.

Eight types of computing results are output continuously.

These are output in the following order:

Sample size	
Maximum value	R (MAX)
Minimum value	R (MIN)
Average	R (AVE)
Width of dispersion	R (P-P)
Sigma ( $\sigma$ )	R ( $\sigma$ )
Average + 3 sigma	R (UCL)
Average - 3 sigma	R (LCL)

R6561  
DIGITAL MULTIMETER  
OPERATION MANUAL

3.13 STATISTICS (Statistical Processing)

When the output of eight types of computing results ends, the display returns to the output mode set wait status (the display of step ⑩ above).

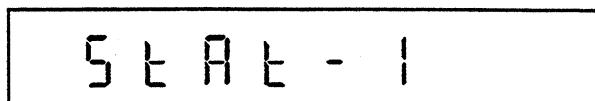

- End of Continuous Output Mode

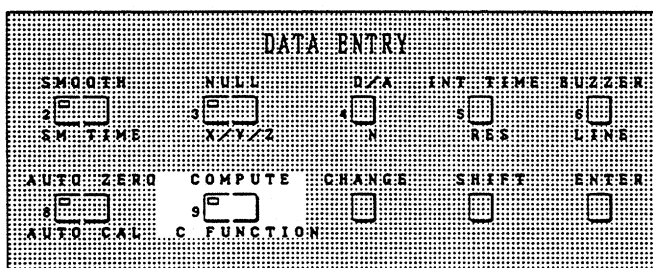

⑬ Press the COMPUTE key.

The COMPUTE lamp goes off, the continuous output mode ends, and the display returns to the measuring mode.

[Notes on Display until the Sample Size Reaches a Specified Value]

When the STATISTICS computing is specified, the object data in execution of the computation is displayed in the display block until the sample size reaches a specified value.

Since the display becomes the output mode set waiting status when the sample size reaches the specified value, the result of STATISTICS computing is displayed according to the reading method.

[Note on Execution of Computing]

- ① Data which exceeds the range set in the execution of the STATISTICS computing becomes invalid and is not included in the number of measured times.
- ② When the measuring function is changed during the execution of the STATISTICS computing, the data in the previous function is initialized and the computing is continued anew.

R6561  
DIGITAL MULTIMETER  
OPERATION MANUAL

3.13 STATISTICS (Statistical Processing)

---

[Notes on Operation]

- ① When the  $\#0$  (HOME key) is pressed during the execution of the STATISTICS computing, the STATISTICS computing is executed up to the currently specified measuring time and the display becomes the output mode set wait status.
- ② When the  $\#0$  (HOME key) is pressed during the reading of the result of STATISTICS computing, the reading ends. (Since the lamp in the COMPUTE key remains lighted, the STATISTICS computing is started anew.)
- ③ When the COMPUTE key is pressed during the setting of the reading mode, the STATISTICS computing is halted, and at the same time, the STATISTICS computing result reading mode ends. The display then returns to the measuring mode.
- ④ The  $\#0$  (HOME key) and COMPUTE key may be pressed at any time.



R6561  
DIGITAL MULTIMETER  
OPERATION MANUAL

4.1 Outline

---

4. GPIB INTERFACE

4.1 Outline

Since the GPIB interface is mounted on the R6561 as a standard, the unit can be connected to the measuring bus GPIB of the IEEE Standard 488-1978.

This chapter describes the standards and functions of the GPIB interface.

R6561  
DIGITAL MULTIMETER  
OPERATION MANUAL

4.2 Outline of GPIB

---

4.2 Outline of GPIB

The GPIB is an interface system which allows this digital multimeter to be connected to the controller and peripheral equipment with a simple cable (bus line). As compared with conventional interfacing methods, the GPIB is readily expanded, easy to use, and also compatible with other companies products electrically, mechanically, and functionally. It can therefore support a wide range of equipment from a simple system to a sophisticated automatic measuring system through a connection with a piece of bus cable.

It is first necessary in this GPIB system to connect each "address" of the individual component devices to the system through the bus line. Each of these devices can play one or more of three kinds of roles, - controller, talker, and listener.

During system operation, one "talker" only can transmit data to the bus line and two or more "listeners" can receive that data.

The controller can transfer data from the "talker" to the "listener" by specifying the address of the "talker" and "listener", or the controller itself ("talker") can set measuring conditions to the "listener".

Eight data lines of bit parallel and byte serial types are used to allow data transfer among these devices in both directions asynchronously.

Because of the asynchronous system, it is possible to freely connect high speed devices to low speed devices.

The data (messages) to be exchanged between equipment includes measuring data, measuring conditions (programs), and various commands. ASCII code is used.

In addition to the above-mentioned eight data lines the GPIB provides three hand-shake lines to control the exchange of asynchronous data between devices and also five control lines to control the flow of data on the bus.

- The hand-shake lines use the following signals:

DAV (Data Valid):

A signal that indicates whether the data is effective.

NRFD (Not Ready For Data):

A signal that indicates the data reception ready status

NDAC (Not Data Accepted):

A signal that indicates end of reception



R6561  
DIGITAL MULTIMETER  
OPERATION MANUAL

4.2 Outline of GPIB

- The control lines use the following signals:

**ATN (Attention):**

A signal used to distinguish whether the signal on the data line is an address, command, or other information

**IFC (Interface Clear):**

A signal used to clear the interface

**EOI (End or Identify):**

A signal used to end transmission of information

**SRQ (Service Request):**

A signal used to request service from an optional equipment to the controller

**REN (Remote Enable):**

A signal used for remote control of remote-programmable equipment

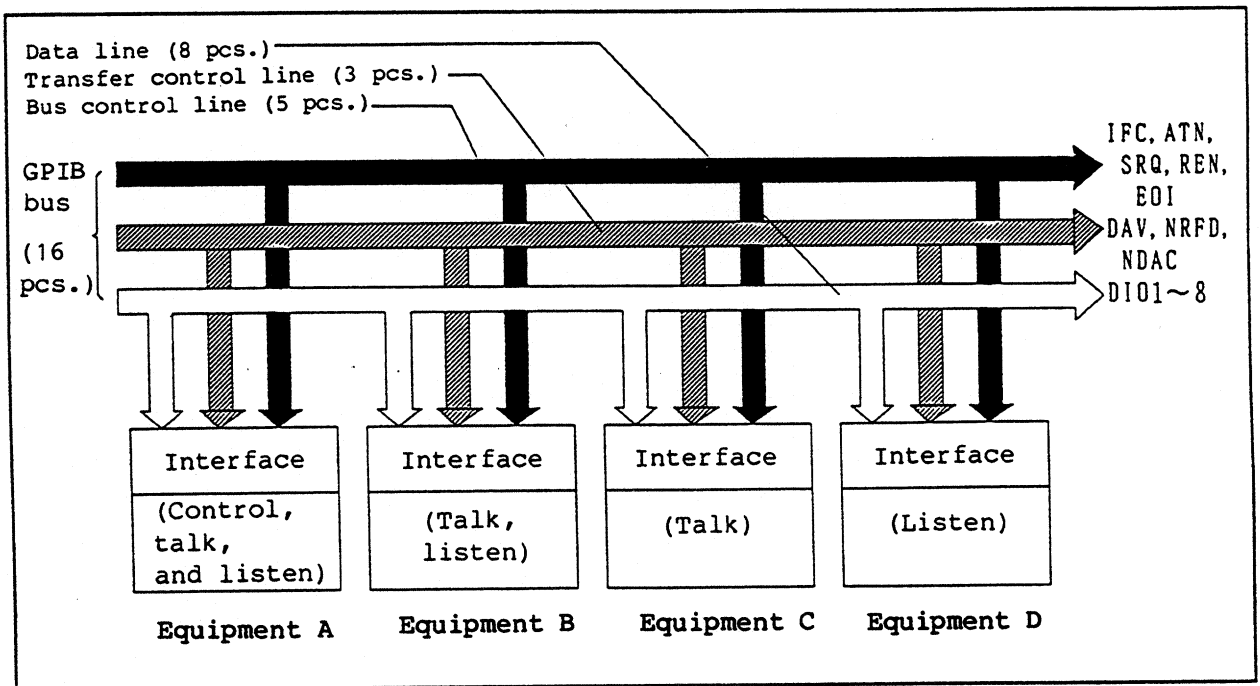

Figure 4 - 1 Outline of GPIB

R6561  
DIGITAL MULTIMETER  
OPERATION MANUAL

4.3 Standards

4.3 Standards

Conformable standards : IEEE Standard 488-1978  
Code used : ASCII codes  
Logical level : Logical 0 "High" status +2.4V or more  
Logical 1 "Low" status +0.4V or less  
Signal line termination: Sixteen bus lines are terminated as shown in the figure below:

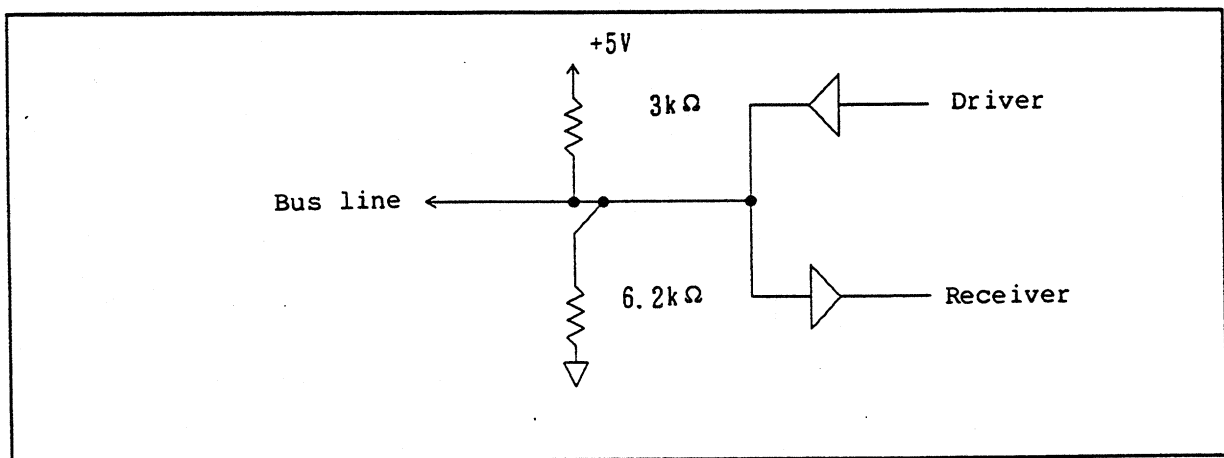

Figure 4 - 2 Signal Line Termination

Specification of driver: Tristate system

"Low" status output voltage : +0.4V or less; and 4.8mA

"High" status output voltage: +2.4V or mroe; and -5.2mA

Specifications of receiver:

"Low" status at +0.6V or less

"High" status at +2.0V or mroe

Length of bus cable:

The length of all bus cables must be (the number of devices connected to bus) x 2m or less, and must not exceed 20m.

Specification of address:

By selecting the GPIB key on the front panel, 31 kinds of talk-address/listen-address can be arbitrarily set.

R6561  
DIGITAL MULTIMETER  
OPERATION MANUAL

4.3 Standards

Connector: 24-pin GPIB connector  
57FE-20240-20SD35 (Equivalent to the product of Daiichi Denshi Kogyo KK)

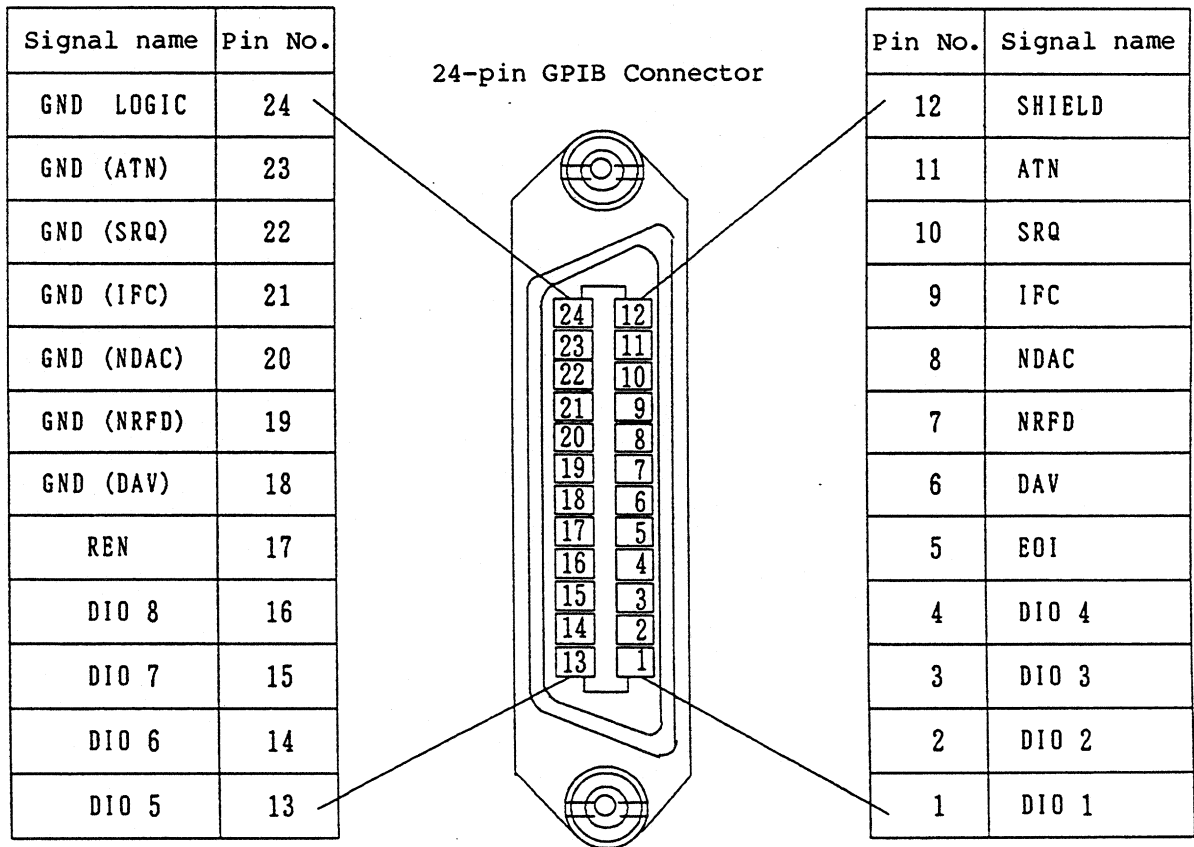

Figure 4 - 3 GPIB Connector Pin Assignment Diagram

R6561  
DIGITAL MULTIMETER  
OPERATION MANUAL

4.3 Standards

Interface function: See Table 4-1.

Table 4 - 1 Interface Function

Code	Function and description
SH1	Source hand-shake function
AH1	Acceptor hand-shake function
T5	Basic talker function, serial polling function, talk only mode function, and talker clearing function by listener specification
L4	Basic listener function and listener clearing function by talker specification
SR1	Service request function
RL1	Remote/local selecting function
PP0	No parallel function provided
DC1	Device clearing function ("SDC" and "DCL" commands available)
DT1	Device trigger function ("GET" command available)
C0	No controller function provided
E2	Tristate bus driver used

R6561  
DIGITAL MULTIMETER  
OPERATION MANUAL

4.4 GPIB Handling Method

---

4.4 GPIB Handling Method

4.4.1 Connection to Component Devices

Since the GPIB system is composed of a multiple devices, prepare the system as a whole while paying attention especially to the following points:

- (1) Prior to connection, check for the status (preparation) and operation of each equipment, referring to the operation manual of the R6561, controller, and peripheral equipments, etc.
- (2) Care should be taken not to make the cables connected to this multimeter and the bus cables connected to the controller, etc., any longer than necessary. Also, be sure to use the bus cable in a range that does not exceed its standard length. The length of all bus cables is (the number of equipments connected to the bus) x 2 meters or less, and must not exceed 20 meters. Standard bus cables provided for this equipment are as listed in Table 4-2.

Table 4 - 2 Standard Bus Cables (to be purchased at cost)

Length	Cable name
0.5m	408JE-1P5
1m	408JE-101
2m	408JE-102
4m	408JE-104

- (3) The bus cable connector are the piggy-back type comprising both a male and a female connector. No more than three bus cables should be connected together, and they must be firmly secured with connector setscrews.
- (4) After checking the power supply conditions, grounding conditions, and setting conditions when necessary, turn ON the power to each component equipment. Be sure to set the power of all equipments to ON. If any equipment is not set to ON, the operation of the whole system is not guaranteed.
- (5) When connecting or disconnecting a cable, be sure to first remove the power cable from the socket.

R6561  
DIGITAL MULTIMETER  
OPERATION MANUAL

4.4 GPIB Handling Method

---

4.4.2 Preparations for Operation

Prior to the execution of measurement from the GPIB, make the following preparations:

- (1) Connect a measured object to the R6561.
- (2) Check the following three points with the GPIB key on the front panel:
  - (a) Device address (0 to 30)
  - (b) R6561 address mode (Addressable/Talk only)
  - (c) Format mode when measurement data is output (Header ON/OFF)
- (3) Make any other settings on the front panel as necessary.

\*1 For the setting method, see Section 2.7.

\*2 For device addresses

The device address is written in ASCII code, not in numerics of 0 to 30, in the controller according to its type. See Table 4-3 in this case.

R6561  
DIGITAL MULTIMETER  
OPERATION MANUAL

4.4 GPIB Handling Method

Table 4 - 3 ASCII Code Coordination Address Codes Table

ASCII code character		Decimal code
LISTEN	TALK	
SP	@	00
!	A	01
"	B	02
#	C	03
\$	D	04
%	E	05
&	F	06
'	G	07
(	H	08
)	I	09
*	J	10
+	K	11
,	L	12
-	M	13
.	N	14
/	O	15
0	P	16
1	Q	17
2	R	18
3	S	19
4	T	20
5	U	21
6	V	22
7	W	23
8	X	24
9	Y	25
:	Z	26
;	[	27
<	\	28
=	]	29
>	-	30

#### 4.4.3 General Notes on Operation

(1) Note on Use of Only Mode

CAUTION

When this equipment is used in the talk only mode, do not operate the controller concurrently.

When the controller is used in the talk only mode, normal operation is not guaranteed.

(a) For the method of setting the equipment to the talk only mode, see Section 2.7.

(b) Set the address mode of the mated equipment connected to this equipment through the bus line to the talk only mode.

(2) Note when the Address Setting is Changed during the Operation

This equipment continues operation as is when the address is changed during operation. When the address is specified a new from the controller before its change, the equipment ignores it. Consequently, it is then necessary to set the program to the new address.

(3) When the power is turned ON, and upon receipt of commands, this equipment enters the status shown in Table 4-4.

(4) When the "ATN" request interrupts in the middle of message transfer between devices, the "ATN" has priority and the previous status is cleared.



R6561  
DIGITAL MULTIMETER  
OPERATION MANUAL

4.4 GPIB Handling Method

Table 4 - 4 Status Change by Command

Command/code	Talker (with lamp provided)	Listener (with lamp provided)	Remote (with lamp provided)	SRQ (with lamp provided)	Status byte	Send data
POWER ON	Clear	Clear	Local	Clear	Clear	Clear
IFC	Clear	Clear	—	—	—	—
"DCL"/"SDC" command	Clear	—	—	Clear	Clear	Clear
"C"*/"Z"* code	Clear	Set	Remote	Clear	Clear	Clear
"GET" command	Clear	—	—	—	Bit b0 cleared	Clear
"E"* code	Clear	Set	Remote	—	Bit b0 cleared	Clear
TALKER specification for this equipment	Set	Clear	—	—	—	—
TALKER CLEAR command	Clear	—	—	—	—	—
LISTENER specification for this equipment	Clear	Set	—	—	—	—
LISTENER CLEAR command	—	Clear	—	—	—	—
Serial polling	—	Clear	—	Clear	—	—

Note: " \*" indicates a program code.

R6561  
DIGITAL MULTIMETER  
OPERATION MANUAL

4.5 Talker Format

4.5 Talker Format

The output data is output in ASCII code.

The talker format is divided into a general format and STATISTICS computation output format.

The following is a description of these two formats.

4.5.1 General Format

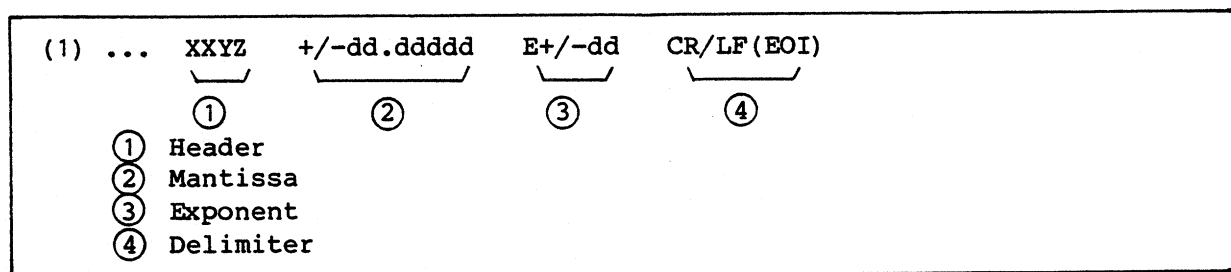

Here, a part of the general format indicated in (1) is shown below. There are 12 patterns in the general format as follows:

- (a) XYZ +/- dd.ddd E+/-dd CR/LF(EOI)
- (b) XYZ +/- dd.ddd E+/-dd LF
- (c) XYZ +/- dd.ddd E+/-dd (EOI)
- (d) +/- dd.ddd E+/-dd CR/LF(EOI)
- (e) +/- dd.ddd E+/-dd LF
- (f) +/- dd.ddd E+/-dd (EOI)
- (g) XYZ +/- dd.ddd E+/-dd CR/LF(EOI)
- (h) +/- dd.ddd E+/-dd (EOI)
- (i) XYZ +/- dd.ddd E+/-dd CR/LF(EOI)
- (j) +/- dd.ddd E+/-dd (EOI)

The above patterns can be summarized as shown in Table 4-5 when divided into header, number of measured digits, delimiter, and the number of characters (bytes).

R6561  
DIGITAL MULTIMETER  
OPERATION MANUAL

4.5 Talker Format

Table 4 - 5 Summary of General Format

	Header	Number of measured digits	Delimiter	Number of characters (bytes)
(a)	ON	4-1/2 digit	CR/LF (EOI)	17
(b)	ON	4-1/2 digit	LF	16
(c)	ON	4-1/2 digit	(EOI)	15
(d)	OFF	4-1/2 digit	CR/LF (EOI)	13
(e)	OFF	4-1/2 digit	LF	12
(f)	OFF	4-1/2 digit	(EOI)	11 (Minimum)
(g)	ON	5-1/2 digit	CR/LF (EOI)	18
(h)	OFF	5-1/2 digit	(EOI)	12
(i)	ON	6-1/2 digit	CR/LF (EOI)	19 (Maximum)
(j)	OFF	6-1/2 digit	(EOI)	13

CAUTION

Since both "CR" and "LF" exist as ASCII code, the "CR" is counted as one byte, as is the "LF" byte.

Since the single-wire signal "EOI" is sent through a separate signal line, it is not counted in the number of characters (bytes).

① Header (four-digit alphabetical characters, or omitted): XXYZ

The header indicates the type of output data. It is composed of two-character main header (XX) and two-character subheader (YZ).

The main header (XX) and subheader (YZ) have the following meanings:

- (a) Main header (XX): Type of computing function
- (b) Subheader (Y) : Type of primary computation
- (c) Subheader (Z) : Type of secondary computation

The header mode is omitted when set to OFF.

Table 4-6 shows the types of measuring functions, primary computation, and secondary computation.

R6561  
DIGITAL MULTIMETER  
OPERATION MANUAL

4.5 Talker Format

Table 4 - 6 General Format Header

Main header (XX)	Type of output data
DV	DC voltage measurement
VL	Low voltage DC measurement
R	HI-P mode resistance measurement
RL	LO-P mode resistance measurement
Subheader (Y)	Type of primary computation and others
┐ (space)	off
S	Scaling
P	% deviation
D	Difference from the previous measured value (delta)
M	Multiplication with the previous measured value (multiply)
B	dB conversion
R	Effective value (rms)
W	dBm conversion
T	Resistance value temperature correction
O	Overscale delta
E	Computation error data
Subheader (Z)	Type of secondary computation
┐ (space)	off
H	Comparator (HIGH)
P	Comparator (PASS)
L	Comparator (LOW)
C	STATISTICS computation (Sample size)
X	STATISTICS computation (MAX)
N	STATISTICS computation (MIN)
A	STATISTICS computation (AVE)
K	STATISTICS computation (P-P)
S	STATISTICS computation ( $\sigma$ )
Y	STATISTICS computation (UCL, AVE+3 $\sigma$ )
Z	STATISTICS computation (LCL, AVE+3 $\sigma$ )

Example: Actual example of general format headers

DV┐┐: Data of DC voltage measurement

DVM┐: Data on which the primary computation (resistance value temperature correction) is made after the measurement of DC voltage

R┐TH: Data obtained when the primary computation (resistance value temperature correction) and secondary computation are made after the measurement of the HI-P mode resistance, and the result is HIGH

R6561  
DIGITAL MULTIMETER  
OPERATION MANUAL

4.5 Talker Format

Note: The comparator result in the secondary computation is the same header in either of the HIGH/LOW or LIMIT setting. Header "H" is output when the result is either HIGH1 or HIGH2, while header "L" is output when the same result is either LOW1 or LOW2. The header when the result of COMPARATOR 1 computation is HIGH or LOW becomes a space " ".

- ② Mantissa (Polarity + decimal points + characters of 4-1/2 to 6-1/2 digit): +/- dd.dddd

The mantissa of a measured value is a variable length of 7 to 9 bytes including the polarity and decimal points, to which the number of digits corresponding to this equipment and the position of decimal point are output.

The polarity is output in a "+" or "-" code when a DC voltage or low voltage DC is measured, and in a " " (space) code when a resistance is measured.

Table 4-7 shows the mantissa and exponent under various measuring conditions.

- ③ Exponent ("E" + polarity + two-digit characters): E+/- dd

The data of the exponent is determined from a measuring function and measuring range. This is because all measurement data is expressed as a basic unit (V or  $\Omega$ ).

Table 4-7 shows the mantissa and exponent under various measuring conditions.

The mantissa is related to the unit of measuring range.

Pay attention to the unit of measuring range and the numeric value in the exponent in the same table. A relationship is seen between the two as shown below:

$\mu$ V : E-06  
mV, m $\Omega$ : E-03  
V,  $\Omega$  : E+00  
k $\Omega$  : E+03

Example: In the case of 1000mV range  
If the display of the mantissa is assumed to be 30.000, this indicates 30mV. Since the exponent of this range is -3, the numeric value can be obtained according to the following equation:

$$30 \times 10^{-3} = 0.03 \text{ (V)}$$

Where, 0.03 is the expression of 30mV in basic units (V).

R6561  
DIGITAL MULTIMETER  
OPERATION MANUAL

4.5 Talker Format

Table 4 - 7 Mantissa and Exponent Under Various Measuring Conditions

Function		Range	Mantissa	Exponent
DC voltage measurement		1000mV	+/-dddd.ddd	E-03
		10V	+/-dd.ddddd	E+00
		100V	+/-ddd.dddd	E+00
		500V	+/-0ddd.ddd	E+00
Low voltage DC measurement		1000ΩV	+/-dddd.dd	E-06
		10mV	+/-dd.ddddd	E-03
		100mV	+/-dd.ddddd	E-03
		1000mV	+/-dddd.ddd	E-03
		10V	+/-dd.ddddd	E+00
Resistance measurement	HI-P mode	1000mΩ	dddd.ddd	E-03
		10Ω	dd.ddddd	E+00
		100Ω	ddd.dddd	E+00
		1000Ω	dddd.ddd	E+00
		10kΩ	dd.dddd	E+03
	LO-P mode	100mΩ	ddd.ddd	E-03
		1000mΩ	dddd.dd	E-03
		10Ω	dd.dddd	E+00
		100Ω	ddd.ddd	E+00
		1000Ω	dddd.d	E+00

d: a numeric character from 0 to 9 (depending on the measurement data)

\* In the case where the measurement exceeds the range, the following messages are output:

XXO +/-99999.E+19 (when 4-1/2 digit are measured)  
 XXO +/-999999.E+19 (when 5-1/2 digit are measured)  
 XXO +/-9999999.E+19 (when 6-1/2 digit are measured)

\* In the case of computation error, the following messages are output:

XXE 99999.E+19 (when 4-1/2 digit are measured)  
 XXE 999999.E+19 (when 5-1/2 digit are measured)  
 XXE 9999999.E+19 (when 6-1/2 digit are measured)

Note: Both the mantissa and exponent, when a computation is executed, output the number of digits and the position of the decimal points corresponding to the display of this equipment as in the general format.

For the output format of the STATISTICS computation, see Section 4.5.2.

R6561  
DIGITAL MULTIMETER  
OPERATION MANUAL

4.5 Talker Format

④ Block Delimiter

This delimiter is output to indicate the end of one set of data.

The block delimiter can be selected from among the following three types according to program code "DLd".

- (a) Outputs two-byte "CR" or "LF" data, and single-wire signal "EOI" at the same time as "LF" is output.
- (b) Outputs one-byte "LF" data.
- (c) Outputs the single-wire signal "EOI" simultaneously with the last byte of data.

CAUTION

Since both "CR" and "LF" exist as ASCII code, the "CR" is counted as one byte.

Since the single-wire signal "EOI" is sent through a separate signal line, it is not counted in the number of characters (bytes).

4.5.2 Output Format in Execution of STATISTICS Computation

<u>XXYC ddddd</u> , ①       ②	: Sample size
XXYX+/-ddd.ddddE+/-dd, XXYN+/-ddd.ddddE+/-dd, XXYA+/-ddd.ddddE+/-dd, XXYK+/-ddd.ddddE+/-dd, XXYS+/-d.dddddE+/-dd, XXYY+/-ddd.ddddE+/-dd, XXYZ+/-ddd.ddddE+/-dd, <u>CR/LF(EOI)</u>	: Maximum value : Minimum value : Average : peak to peak : $\sigma$ : Average +3 $\sigma$ : Average -3 $\sigma$

③

- ① Sample Size
- ② String Delimiter
- ③ Block Delimiter

The result of STATISTICS computation is output (eight items).

① Sample Size

Header + the number of five digits. The other seven items (the maximum value to average -3) are the same as Section 4.5.1 (1), General Format.

② String Delimiter

This delimiter is output to indicate the end of one string. The string delimiter can be selected from among the following three types depending on program code "SLd":

- (a) ", "
- (b) " " (space)
- (c) "CR/LF"

③ Block Delimiter

The content indicated in this block is the same as Section 4.5.1 ④, Block Delimiter.

\* In the case of the step output mode, the string delimiter in the above format is replaced with the block delimiter.



R6561  
DIGITAL MULTIMETER  
OPERATION MANUAL

4.6 Listener Format

4.6 Listener Format

This equipment can control the setting of each parameter and operation using the controller.

Table 4-8 shows the program code corresponding to each parameter.

Table 4 - 8 Program Code (1 of 7)

Item	Code	Content
Measuring function	F1	*
	F2	*
	F3	*
	F4	*
Measuring range	Rd	d = 0 to 8
	d=0	* See Table 4-9.
Sampling mode	M0	* RUN
	M1	* HOLD
Control parameter	AC	This code implements AUTO CALIBRATION.
	CI ddd	ddd: 0 to 999
	d=1	* This code specifies the interval to (Unit: minute) 0 : off 1 to 999: Can be set with an interval of one minute
	AZ0	This code specifies whether or not the AUTO ZERO CALIBRATION function is adopted. off
	AZ1	* on
Control parameter	BZ0	This code specifies the BUZZER mode. off
	BZ1	on1 (when the result of comparator computation is HIGH/LOW)
	BZ2	on2 (when the result of comparator computation is PASS)

\* Initial value

R6561  
DIGITAL MULTIMETER  
OPERATION MANUAL

4.6 Listener Format

Table 4 - 8 Program Code (2 of 7)

Item	Code	Content
Control parameter	CFd1, d2  d1, d2=0       *	This code specifies the computing function.  d1: 0 to 8, primary computation mode 0: off 1: scaling 2: % deviation 3: Delta (difference from the previous measured value) 4: Multiply (multiplication with the previous measured value) 5: dB conversion 6: rms (effective value) 7: dBm conversion 8: Resistance value temperature correction  d2: 0 to 3, Secondary computation mode 0: off 1: COMPARATOR 1 (when constant HIGH/LOW is used) 2: COMPARATOR 2 (when constant LIMIT is used) 3: STATISTICS computation - Both d1 and d2 cannot be omitted.
	CO0 CO1               *	This code specifies whether to execute the computing function. off on
	DA0 DA1  DA2  DA3  DA4               *	These codes specify the analog output mode. off Outputs low order three digits of the displayed data. Outputs low order three digits of the displayed data with the offset (500) added. Outputs low order two digits of the displayed data. Outputs low order two digits of the displayed data with the offset (50) added.

\* Initial value

R6561  
DIGITAL MULTIMETER  
OPERATION MANUAL

4.6 Listener Format

Table 4 - 8 Program Code (3 of 7)

Item	Code	Content
Control parameter	H0	Specifies the GPIB output format. No header is added when the data is output.
	H1	* Header is added when the data is output.
	IT0 IT1 IT2 IT3 IT4 IT5	* These codes specify the integrate time. 1PLC 5PLC 10PLC 20PLC 50PLC 100PLC
	KNd..d d=2	d..d: 2 to 10000 This code specifies the sample size in the STATISTICS computation.
	Kn +/-d..d E+/-d  KnMD  n = X, Y, Z  X, Z=1, Y=0	+/-d..d: Mantissa data Code + numeric characters in less than seven digits + decimal points -1999999 to 1999999  E+/-d : Exponent data "E" + code + one-digit numeric character 0 to 9  * Constants used in computation are set as follows: - Decimal points can be omitted. - When the previous measured value is set as a constant, use "KnMD" (n = X, Y, Z). - The exponent data can be omitted.
HI1 +/-d..d E+/-d HI2 +/-d..d E+/-d LO1 +/-d..d E+/-d LO2 +/-d..d E+/-d  HI=1, LO=0	+/-d..d: Mantissa data Code + numeric characters in less than seven digits + decimal points -1999999 to 1999999  E+/-d : Exponent data "E" + code + one-digit numeric character 0 to 9  * Constants used in the COMPARATOR computation are set as follows: - Decimal points can be omitted. - The exponent data can be omitted.	

\* Initial value

R6561  
DIGITAL MULTIMETER  
OPERATION MANUAL

4.6 Listener Format

Table 4 - 8 Program Code (4 of 7)

Item	Code	Content
Control parameter	LI +/-d..d dE+/-d d..d, d..d	<p style="text-align: center;">+/-d..dE+/-d, d..d, d..d</p> <div style="text-align: center;"> </div> <p style="text-align: center;">Reference value</p> <p>Reference value =1 * %1=10 * %2=10</p> <p>* Reference value: * Mantissa data; * Code + numeric characters in less than seven digits + decimal points -1999999 to 1999999 Exponent data; "E" + code + one-digit numeric character 0 to 9 %1, %2: 0.000 to 100.0 Decimal points + numerical characters in less than four digits These codes are used in the COMPARATOR computation to set a judgment level as +/- % to reference value as follows: - Decimal points can be omitted. - The exponent data of reference value can be omitted. - The %1 and %2 data cannot be omitted.</p>
	LF50 LF60	<p>These codes specify the power supply frequency in use. 50Hz 60Hz</p>
	RE4 RE5 RE6	<p>These codes specify the number of measured digits. 4-1/2 digit (11999) 5-1/2 digit (119999) * 6-1/2 digit (1199999)</p>
	NL0 NL1	<p>These codes specify whether or not the NULL function is executed. * off on</p>

\* Initial value

R6561  
DIGITAL MULTIMETER  
OPERATION MANUAL

4.6 Listener Format

Table 4 - 8 Program Code (5 of 7)

Item	Code	Content
Control parameter	SM0 SM1	* These codes specify whether or not the SMOOTHING function is executed. off on
	Tid..d d=10	* d: 2 to 100 This code specifies the number of smoothing times.
	SH0  SH1	* Specifies the output mode of the result of STATISTICS computation. Step output mode to output data units one by one (Use the "RN" code from the second data on.) Continuous output mode to output eight data units consecutively.
	RN	This is an effective code when the step output mode is specified. For data after the second order among eight types of data, this code requests the output of the next data.
Others	E	Measurement start instruction code This has the same meaning as the "TRIG" key on the front panel. This code implements the same process as the "GET" command.
	C	This code initializes the setting for the GPIB. This code implements the same process as the "DCL" and "SDC" commands.
	Z	This code sets each parameter to its initial value. This code also executes the program code "C" process.
	S0 S1	* These codes specify whether or not the SRQ signal is transmitted. Transmits the SRQ signal. Does not transmit the SRQ signal.

\* Initial value

R6561  
DIGITAL MULTIMETER  
OPERATION MANUAL

4.6 Listener Format

Table 4 - 8 Program Code (6 of 7)

Item	Code	Content																											
Others	SL0 SL1 SL2	<p>When multiple data units are output (output of the STATISTICS computing results), this code specifies the data (string delimiter) to be output as the delimiter of each data as follows:</p> <p>Outputs ", ". Outputs " " (space). Outputs "CR/LF".</p>																											
	DL0 DL1 DL2	<p>These codes specify a block delimiter when data is output.</p> <p>Outputs the single-wire signal (EOI) when "CR/LF" and "LF" are output. Outputs "LF". Outputs the single-wire signal (EOI) when the last data is output.</p>																											
	CS	<p>This code clears the status byte to 0. When the SRQ signal is generated, this code sets the signal to FALSE (stops the signal transmission).</p>																											
	MSddd d=0	<p>ddd: 0 to 255</p> <p>This code masks the specified bit of the status byte. The bit to be masked is specified by ddd and the bit set at "1" is masked. (A decimal set by ddd is converted into a binary value and then masked.) However, bit 6 (RQS) cannot be masked (although it can be set).</p> <div style="text-align: center; margin-top: 10px;"> <table style="border-collapse: collapse; margin: auto;"> <tr> <td style="padding-right: 5px;">Bit</td> <td style="padding: 0 5px;">7</td> <td style="padding: 0 5px;">6</td> <td style="padding: 0 5px;">5</td> <td style="padding: 0 5px;">4</td> <td style="padding: 0 5px;">3</td> <td style="padding: 0 5px;">2</td> <td style="padding: 0 5px;">1</td> <td style="padding: 0 5px;">0</td> </tr> <tr> <td style="padding-right: 5px;">Status</td> <td style="border: 1px solid black; padding: 2px 5px;">---</td> <td style="border: 1px solid black; padding: 2px 5px;">---</td> <td style="border: 1px solid black; padding: 2px 5px;">---</td> <td style="border: 1px solid black; padding: 2px 5px;">---</td> <td style="border: 1px solid black; padding: 2px 5px;">---</td> <td style="border: 1px solid black; padding: 2px 5px;">---</td> <td style="border: 1px solid black; padding: 2px 5px;">---</td> <td style="border: 1px solid black; padding: 2px 5px;">---</td> </tr> <tr> <td style="padding-right: 5px;">Byte</td> <td style="padding: 0 5px;">128</td> <td style="padding: 0 5px;">64</td> <td style="padding: 0 5px;">32</td> <td style="padding: 0 5px;">16</td> <td style="padding: 0 5px;">8</td> <td style="padding: 0 5px;">4</td> <td style="padding: 0 5px;">2</td> <td style="padding: 0 5px;">1</td> </tr> </table> </div>	Bit	7	6	5	4	3	2	1	0	Status	---	---	---	---	---	---	---	---	Byte	128	64	32	16	8	4	2	1
	Bit	7	6	5	4	3	2	1	0																				
Status	---	---	---	---	---	---	---	---																					
Byte	128	64	32	16	8	4	2	1																					
TE	<p>This code is used to execute self diagnosis.</p>																												

\* Initial value

R6561  
DIGITAL MULTIMETER  
OPERATION MANUAL

4.6 Listener Format

Table 4 - 8 Program Code (7 of 7)

Item	Code	Content
Others	SD+/-d..d	<p>+/-d..d: Code + numeric characters in less than seven digits + decimal points</p> <p>Executes the setting and calibration of a calibrated value.</p> <p>Specifies the calibration of zero point or full scale depending on the value of +/-d..d.</p> <ul style="list-style-type: none"> <li>- For the setting range, see the chapter on calibration.</li> <li>- d..d permits only the data in fixed point representation. (Data having an exponent is not permitted.)</li> <li>- Set d..d to the data corresponding to the display. (If the display is a 10V range, the range becomes 10V when d..d=10.</li> <li>- Code (+) can be omitted.</li> </ul>

Table 4 - 9 Measuring Range Code of R6561

Code	VDC	LOV DC	HIP OHM	LOP OHM
0	auto	auto	auto	auto
1	-	1000 $\mu$ V	-	-
2	-	10mV	-	-
3	-	100mV	-	100m $\Omega$
4	1000mV	1000mV	1000m $\Omega$	1000m $\Omega$
5	10V	10V	10 $\Omega$	10 $\Omega$
6	100V	-	100 $\Omega$	100 $\Omega$
7	500V	-	1000 $\Omega$	1000 $\Omega$
8	-	-	10k $\Omega$	-

R6561  
DIGITAL MULTIMETER  
OPERATION MANUAL

4.6 Listener Format

---

[Important Points when Program Codes are Set]

- (1) The number of program code characters which can be received at a time is 50 max.

(Commentary)

In this equipment, a program code when received is continuously read in the internal buffer and a process corresponding to that program code is performed at the time a terminator is received. Consequently, a restriction is imposed on the number of program code characters which can be received at a time.

The maximum number of characters which can be received at a time is 50. Note that " " (space) codes in the terminator and string are not included in this number of characters.

- (2) Transmit "LF" (¥12) code in the last of the string of one line.

(Commentary)

Transmit "LF" (¥12) code in the last of the string of one line. (It may be replaced with "CR"/"LF".) When the "LF" is not transmitted, output the single-wire signal "EOI" when the last character is transmitted. (Both "LF" and "EOI" may also be output together.)

When neither the "LF" code nor "EOI" signal is output, the end of the string cannot be detected, causing the operation to stop under the hand-shake wait status.

Terminators allowed to be used follow:

- CR/LF (EOI)
- LF (EOI)
- CR (EOI)
- (EOI)
- CR/LF
- LF

- (3) Multiple descriptions can be made in one string in each program code.

(Commentary)

Example:

- "F1R4M1": Allows omission of the delimiter of each program code.  
"F1,R4 ": ", " is used as the delimiter of each program code.  
"F1 R4" : " " (space) is used as the delimiter of each program code.

However, set the following program code independently:

"Cod"



R6561  
DIGITAL MULTIMETER  
OPERATION MANUAL

4.6 Listener Format

---

- (4) Note on characters which can be used in remote programming

(Commentary)

Characters which can be used in remote programming are as follows:

Numeric characters : "1" to "9" and "0"  
Alphabetical characters: "A" to "Z" and "a" to "z"  
Symbols : ",", ".", "+", and "-"  
Others : "CR", "LF", and " " (space)

When any other characters is set, it is treated as a set error.  
(Lower case letters "a" to "z" are treated the same as upper case letters "A" to "Z".)

- (5) Note on format code which cannot be used during setting program

(Commentary)

In case any format code which cannot be used exists in a set program, the program is executed normally up to the program code immediately before that code, but all subsequent codes are ignored.

- (6) Description of factors which cause a syntax error

(Commentary)

Factors causing syntax errors are as follows:

- When a received string exceeds 50 characters (Received strings are all ignored.)
- When a nonexistent program code is received
- When a set data exceeds the specified tolerance range
- When a unusable character is received

When these events occur, the error code is displayed in the panel display block.

- (7) Listener codes which can be received in the CALIBRATION mode (when the "EXT CAL" switch of the rear panel is in the ON status) are:

"AC", "CS", "DLd", "LFdd", "MSddd", "SD+/-d..d", "SLd"  
"C", "Fd", "Hd", "Rd", "Sd", "Z"

- (8) Listener codes which can be received in the output mode as the result of the STATISTICS computation are:

"Cod", "CS", "DLd", "MSddd", "RN", "SHd", "SLd"  
"C", "Hd", "Sd", "Z"

R6561  
DIGITAL MULTIMETER  
OPERATION MANUAL

4.7 Service Request ("SRQ")

---

4.7 Service Request ("SRQ")

4.7.1 Outline

The service request is a function to interrupt the controller to let it know the operating status of a equipment when it enters a specified status.

The operating status is notified using a status byte.

When some equipments transmit the service request, the controller searches for these equipments one by one in order. (This is called a serial polling).

When a equipment is searched for, the controller transmits the SPE (Serial Poll Enable) command to this equipment to let it know that the status byte is ready to be received. Upon receipt of this command, the equipment transmits the status byte to the controller. The controller judges the operating status of the equipment according to this status byte.

4.7.2 Service Request and Status Byte

When the "SO" mode is specified, this equipment transmits the service request to the controller when a measurement ends or a undefined code is received, etc.

When the service request is transmitted, the equipment transmits the status byte to the controller through serial polling by the controller.

In case this equipment is specified as the "SI" mode, this equipment does not transmit the service request, but does transmit the status byte.

Each bit of the status byte is set depending on the operating status of the equipment. When multiple factors occur concurrently, all bits corresponding to each factor are set. Checking the status byte is therefore recommended when the serial polling is executed by masking factors not expected in advance or to judge it by unit of a bit.

All bits excepting bit 6 of the status byte can be masked using the program code "MSnnn". When causing factors are all masked, bit 6 is not set.

The status byte is all cleared to 0 (zero) when the power is turned ON, the "SDC"/"DCL" command is received, and program codes "C", "Z", and "CS" are received. Figure 4-4 shows the relationship between the operating status and each bit.

R6561  
DIGITAL MULTIMETER  
OPERATION MANUAL

4.7 Service Request ("SRQ")

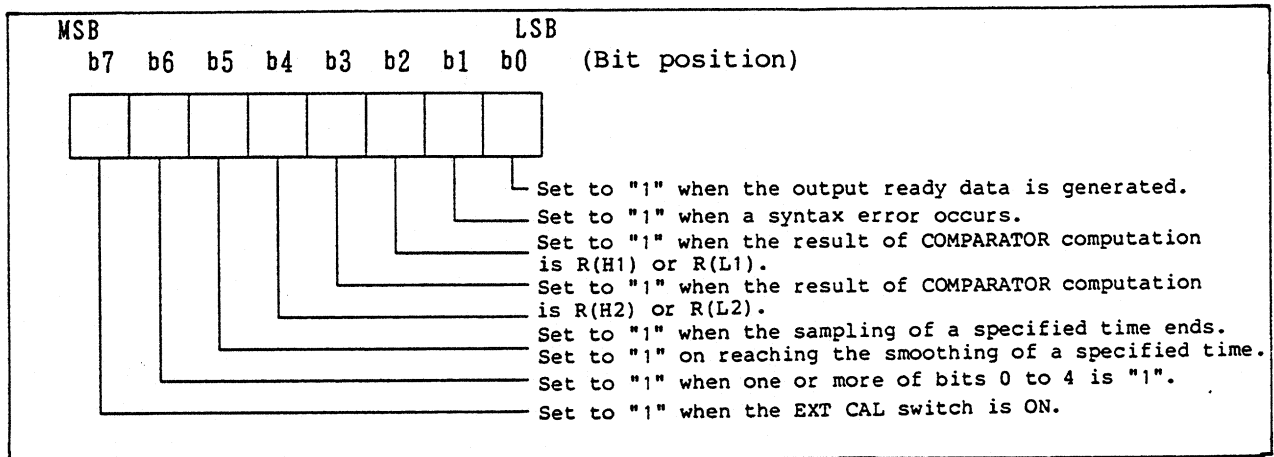

Figure 4 - 4 Relationship between Operation Status and each Bit at the Service Request

4.7.3 Causes for Service Request

Each bit of a status byte is set ("0" → "1") or cleared ("1" → "0") due to the following causes:

(1) Bit b0 (Generation of output ready data)

This bit is set when output ready data, e.g., measurement data and computing result, etc., is generated. This bit is cleared in the following cases:

- When data transmission ends
- When program code "E" or "GET" command is received under the status where the sampling mode is set to HOLD
- When program code "SHd" to output the STATISTICS computing result is received, and when program code "RN" is received in the step output mode

(2) Bit b1 (Occurrence of syntax error)

This bit is set when a setting error exists, such as the use of a undefined program code or improper using conditions or format of a program code in the course of remote programming.

This bit is cleared when the next remote program code is received.

(3) Bit b2 (When COMPARATOR computing result is R(H1) or R(L1))

This bit is set when the computing result is R(H1) or R(L1) under the status where the comparator is set in the secondary computation.

R6561  
DIGITAL MULTIMETER  
OPERATION MANUAL

4.7 Service Request ("SRQ")

---

This bit is cleared when the data transmission ends.

- (4) Bit b3 (When COMPARATOR computing result is R(H2) or R(L2))

This bit is set when the computing result is R(H2) or R(L2) under the status where the comparator is set in the secondary computation.

- (5) Bit b4 (End of sampling of a specified time)

This bit is set in the following cases in the execution of the computation to specify the sample size:

- When the computing result is output each of "X" times of sampling in the execution of the RMS computation
- When "N" times of sampling are executed in the execution of the STATISTICS computation
- When the RMS computing result is output each of "X" times of sampling during execution of both the RMS and STATISTICS computation, and when the computation reaches "X" x "N" times and the computing result is the RMS - STATISTICS computing result.

This bit is cleared in the following cases:

- When the data transmission ends
- When the computing function is set to OFF
- When program code "SHd" to output the STATISTICS computing result is received, or when the HOME key is pressed

- (6) Bit b5 (Specified number of times of smoothing)

This bit is set when the sampling reaches "SM TIME" in the execution of smoothing and the result of smoothing a specified number of times is output.

This bit is cleared in the following cases:

- When the data transmission ends
- When the smoothing function is set to OFF
- When the measuring function, range, integrate time, or the number of smoothing times is changed during the execution of the smoothing.

- (7) Bit b6 (Service request)

This bit is set when one or more of the bits 0 to 5 are "1".  
This bit is cleared when all of the bits 0 to 5 are "0".

R6561  
DIGITAL MULTIMETER  
OPERATION MANUAL

4.7 Service Request ("SRQ")

---

(8) Bit b7 (EXT CAL switch ON status)

This bit is set when the EXT CAL switch of the rear panel is set to the ON status (CALIBRATION mode).

This bit is cleared when the same switch is set to the OFF status.

The status of this bit does not influence bit 6. (This does not cause the transmission of SRQ.)

4.8 Operation Flowchart

Figure 4-5 shows an outline flowchart of the equipment operation.

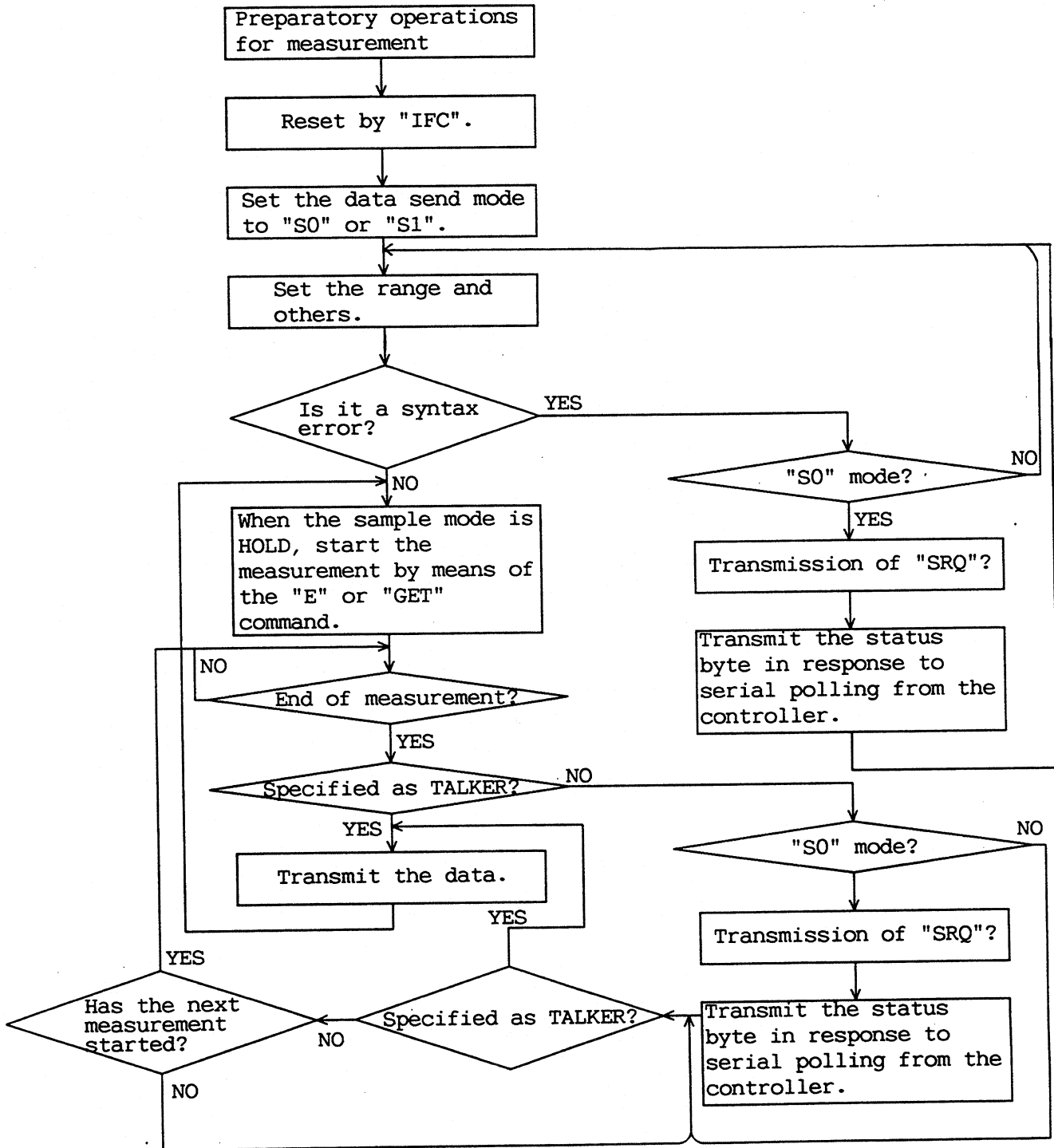

Figure 4 - 5 Flowchart of GPIB Operation

4.9 Operation Note

(1) Operation when a Service Request Occurs

Since the system operates as shown in Figure 4-6 when a service request occurs due to the end of a measurement or syntax error (in the S0 mode), care should be taken in the programming.

(2) Difference in Send Data According to the Timing of the TALKER Specification

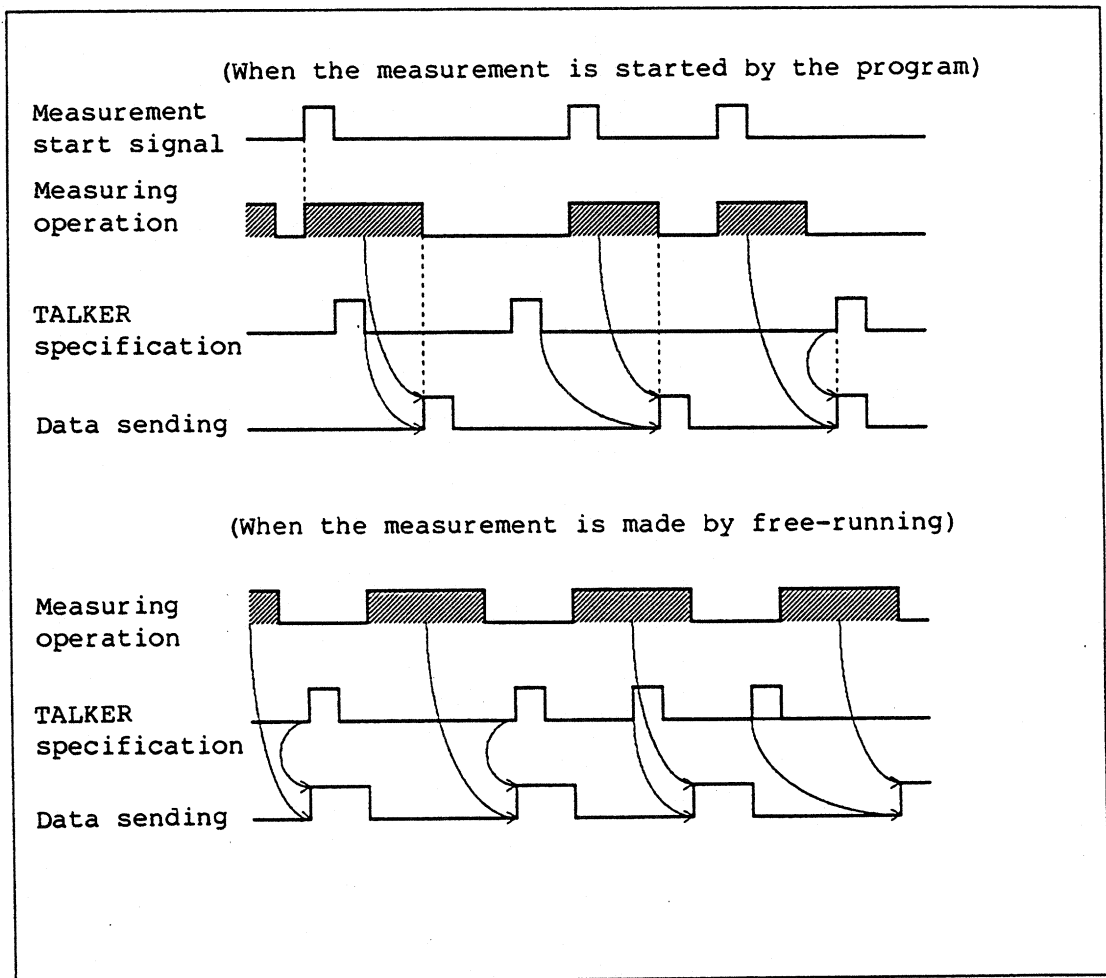

R6561  
DIGITAL MULTIMETER  
OPERATION MANUAL

4.9 Operation Note

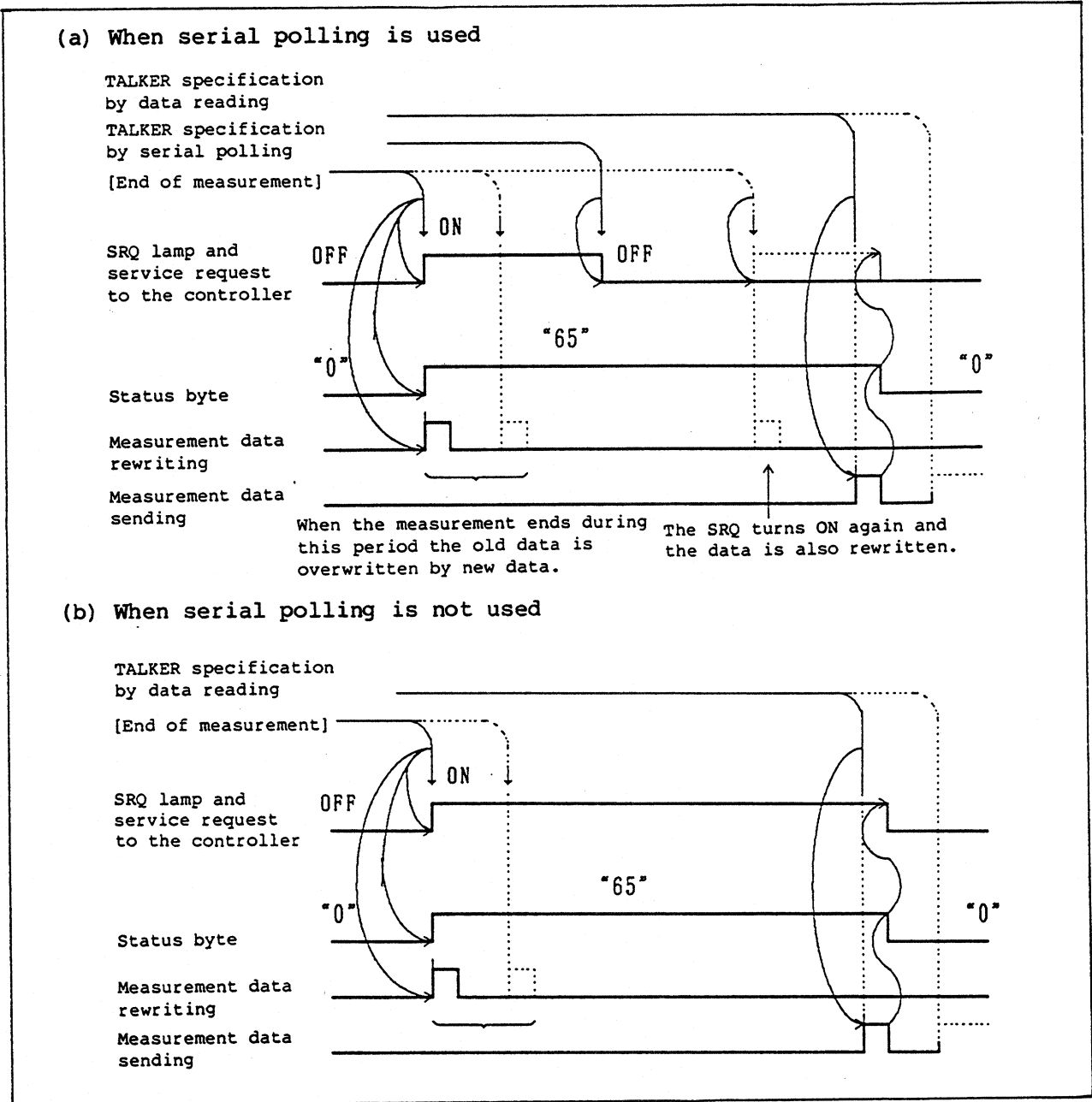

Figure 4 - 6 Operation Timing when a Service Request Occurs (1 of 2)



R6561  
 DIGITAL MULTIMETER  
 OPERATION MANUAL

4.9 Operation Note

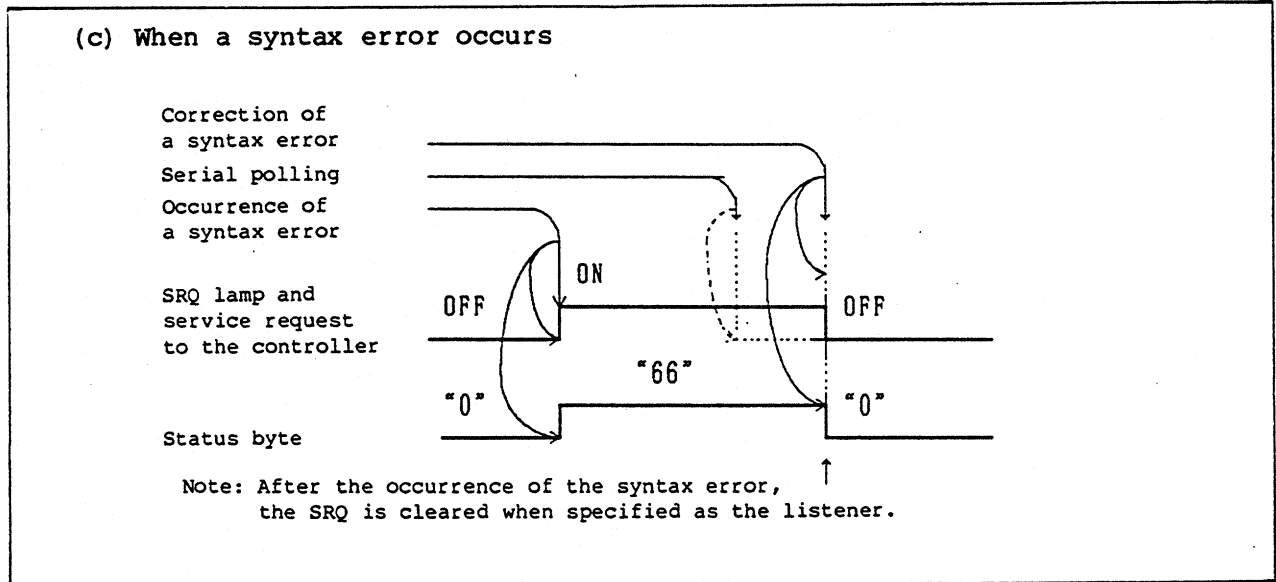

Figure 4 - 6 Operation Timing when a Service Request Occurs (2 of 2)

R6561  
DIGITAL MULTIMETER  
OPERATION MANUAL

4.10 Program Example

4.10 Program Example

The following is a description of three examples of the program generated by using the HP300 series manufactured by the HEWLETT-PACKARD Corporation.

Example 1:

In case the measurement is started by setting measuring parameters and started externally to read data using the SRQ command

```
10      !*****
20      !          TRIGGER  --  SRQ
30      !
40      !          SAMPLING MODE  :  HOLD
50      !*****
60      !
70      DIM A$ [20]
80      R6561=701
90      ON INTR 7 GOSUB Srqint
100     !
110     CLEAR R6561
120     GOSUB Set_para
130     !
140     ENABLE INTR 7;2
150     TRIGGER R6561
160     Wait_f=0
170     IF Wait_f=1 THEN 150
180     GOTO 170
190     !
200     !*****  SRQ interrupt routine  *****
210     !
220  Srqint: STATUS 7,1;X
230           S=SPOLL(R6561)
240           IF S<>65 THEN 280
250           ENTER R6561;A$
260           PRINT A$
270           Wait_f=1
280           ENABLE INTR 7;2
290           RETURN
300     !
310     !*****  set R6561 parameter  *****
320     !
330  Set_para: OUTPUT R6561;"F3, R8, M1, IT3, RE6"
340           OUTPUT R6561;"#1, S0, DLO, CS, MS62"
350           RETURN
360     !
370     END
```

R6561  
DIGITAL MULTIMETER  
OPERATION MANUAL

4.10 Program Example

Description	
70	Define the data area.
80	Set the address of R6561 to a variable named "R6561".
90	Define interrupt processing routine.
110	Initialize the setting for GPIB of R6561 ("SDC").
120	Set each parameter of the R6561.
140	Enable the reception of SRQ.
150	Trigger an external start.
160	Clear the interrupt processing end flag.
170	Loop the processing until the interrupt processing ends
to	(until the flag is set).
180	When interrupt processing is executed, transmit the measurement
	start instruction again.
220	
to	Interrupt processing routine
290	
230	Execute serial polling.
240	Branch to 280 when the service request for output ready data
	generation is not yet transmitted.
250	Receive the data from R6561.
260	Display the data.
270	Set the interrupt processing end flag.
280	Enable the reception of SRQ.
330	Set each parameter of the R6561.
to	"F3" Measuring function : HIP-OHM
350	"R8" Measuring range : 10k $\Omega$
	"M1" Sampling mode : HOLD
	"IT3" Integrate time : 20PLC
	"RE6" Number of display digits: 6.5-digit mode
	"H1" Header output : ON
	"S0" SRQ transmission : ON
	"DL0" Block delimiter : "CR/LF(EOI)"
	"CS" Clears the status byte
	"MS62" Masks status byte excepting bits 0, 6, and 7.
370	End of program

R6561  
DIGITAL MULTIMETER  
OPERATION MANUAL

4.10 Program Example

---

Example 1: Measurement data

```
R 11.9922E+03
R 11.9920E+03
R 11.9913E+03
R 11.9922E+03
R 11.9925E+03
R 11.9919E+03
R 11.9923E+03
R 11.9919E+03
R 11.9923E+03
R 11.9920E+03
R 11.9922E+03
R 11.9922E+03
R 11.9921E+03
R 11.9922E+03
R 11.9919E+03
R 11.9924E+03
R 11.9927E+03
R 11.9926E+03
R 11.9924E+03
R 11.9922E+03
R 11.9920E+03
R 11.9915E+03
R 11.9921E+03
R 11.9920E+03
R 11.9924E+03
R 11.9924E+03
R 11.9917E+03
R 11.9923E+03
R 11.9920E+03
R 11.9919E+03
R 11.9924E+03
R 11.9922E+03
R 11.9920E+03
R 11.9921E+03
R 11.9918E+03
R 11.9921E+03
R 11.9918E+03
R 11.9923E+03
R 11.9924E+03
R 11.9920E+03
R 11.9922E+03
R 11.9921E+03
R 11.9920E+03
R 11.9921E+03
R 11.9925E+03
R 11.9922E+03
R 11.9920E+03
R 11.9920E+03
R 11.9919E+03
```

R6561  
DIGITAL MULTIMETER  
OPERATION MANUAL

4.10 Program Example

Example 2:

Example of Program to Execute STATISTICS Computation

```
10  !*****
20  !      COMPUTING FUNCTION : STATISTICS (N=10)
30  !
40  !      SAMPLING MODE : RUN (use SRQ)
50  !*****
60  !
70  DIM A$(7) [20]
80  INTEGER I
90  R6561=701
100 ON INTR 7 GOSUB Srqint
110 !
120 CLEAR R6561
130 GOSUB Set_para
140 !
150 ENABLE INTR 7;2
160 Ns_end=0
170 OUTPUT R6561;"CO1"
180 Wait_srq: IF Ns_end=0 THEN Wait_srq
190 OUTPUT R6561;"CO0"
200 STOP
210 !
220 !***** SRQ interrupt routine *****
230 !
240 Srqint: STATUS 7,1;X
250         S=SPOLL(R6561)
260         IF BIT(S,4)=0 THEN Rtn
270         GOSUB C_read
280         Ns_end=1
290 Rtn:    ENABLE INTR 7;2
300         RETURN
310 !
320 !***** read computing data *****
330 !
340 C_read: PRINT "----- result of statistics -----"
350         OUTPUT R6561;"SH1"
360         ENTER R6561;A$(0),A$(1),A$(2),A$(3),A$(4),A$(5),A$(6),A$(7)
370         FOR I=0 TO 7
380             PRINT A$(I)
390         NEXT I
400         RETURN
410 !
420 !***** set R6561 parameter *****
430 !
440 Set_para: OUTPUT R6561;"F2, R2, MO, IT3, RE5, CFO, 3, KN10"
450           OUTPUT R6561;"H1, SO, SL2, DLO, CS, MS47"
460           RETURN
470 !
480 END
```

R6561  
DIGITAL MULTIMETER  
OPERATION MANUAL

4.10 Program Example

(1 of 2)

Description	
70	to Define the data area and declare the type of variables.
80	
90	Set the R6561 address to a variable named "R6561".
100	Define the interrupt processing routine.
120	Initialize the setting for the GPIB of the R6561 ("SDC").
130	Set each parameter of the R6561.
150	Enable the reception of SRQ.
160	Clear the interrupt processing end flag.
170	Set the computing function to ON.
180	Loop the processing until the interrupt processing ends (until the flag is set).
190	Set the computing function to OFF.
200	Stop the program execution.
240	Interrupt processing routine
to	
300	
250	Execute serial polling.
260	Branch to 290 when the service request is not transmitted at the end of measurement of a specified time.
270	Read the result of STATISTICS computation.
280	Set the interrupt processing end flag.
290	Enable the reception of SRQ.
340	STATISTICS computing result reading routine
to	
400	
350	Instruction to output the result of STATISTICS computation in the continuous mode.
360	Receives the result of eight types (sample size to LCL) of computation.
370	
to	Displays the computing result.
390	
440	Set each parameter of the R6561.
to	"F2" Measuring function : LovDC
460	"R2" Measuring range : 10mV
	"M0" Sampling mode : RUN
	"IT3" Integrate time : 20PLC
	"RE5" Number of display digits : 5-1/2 digit mode
	"CF0,3" Computing function : STATISTICS computation

R6561  
DIGITAL MULTIMETER  
OPERATION MANUAL

4.10 Program Example

(2 of 2)

```
"KN10" Sample size of STATISTICS computation: 10 samples
"H1"   Header output                          : ON
"S0"   SRQ transmission                        : OFF
"SL2"  String delimiter                       : "CR/LF"
"DL0"  Block delimiter                        : "CR/LF(EOI)"
"CS"   Clear the status byte.
"MS47" Masks the status byte excepting bits 4, 6, and 7.
```

```
480   End of program
```





R6561  
DIGITAL MULTIMETER  
OPERATION MANUAL

5.1 Before Requesting Repair

---

5. MAINTENANCE, CHECK, AND CALIBRATION

5.1 Before Requesting Repair

Should an error occur when using the R6561, be sure to check the following items and contact the nearest dealer or the sales and support office. Their address and telephone No. are given in the end of this manual. Even when the repair is covered by the following check items, the repair expenses will be charged if the repair is made in our company. Before requesting repairs, check the problem referring to the check items shown in the table below:

Symptom	Cause	Remedial action
No display	- Blown fuse	- Replace the blown fuse referring to Item (4) in Section 1.3.3.
Measured values are unstable or abnormal.	- Wrong setting of measuring function and range, etc. - Wrong setting of power supply frequency, 50Hz/60Hz	- Check and correct the any wrong function and range, etc. - Set the frequency to the AC power frequency in use. (See Section 2.7.14)
No measurement is made even when the input signal is applied to the equipment.	- The cable is connected to the wrong terminal. - The key setting to the input terminal is wrong.	- Connect the input cable to the correct input terminal. - Set the key correctly.

R6561  
DIGITAL MULTIMETER  
OPERATION MANUAL

5.2 Error Message

5.2 Error Message

(1) Errors which can Occur During a Routine Operation

- An error has occurred in the measuring operation of the equipment.  
(Hardware trouble)

Error 1

- Wanted to make a calibration, but the EXT CAL switch is not set to ON.

Wanted to make a calibration, but the calibration value input from the GPIB is out of the set range.

Error 2

- Wanted to make a calibration, but the calibration value is out of range.

Error 3

- Wanted to set a parameter through the panel, but its set value is out of range.

Error 4

- Wanted to execute a computation, but the setting of constants is improper.

Error 5

R6561  
DIGITAL MULTIMETER  
OPERATION MANUAL

5.2 Error Message

- A computation error has occurred.

Error 6

- No listener code exists corresponding to those sent from the GPIB.

Error 10

- The string length of the listener code sent from the GPIB exceeds 50 characters.

Error 11

- Use conditions or data of the listener code sent from the GPIB are inappropriate.

Error 12

(2) Errors which can Occur in Self Test

- An error has occurred in a program ROM test.

Error RO

- An error has occurred in a calibration data test. (Displays error Nos. 1 to 18.)

Error 1 CA

R6561  
DIGITAL MULTIMETER  
OPERATION MANUAL

5.2 Error Message

---

- An error has occurred in a basic measuring operation test.  
(Displays error Nos. 1 to 6.)

E r r o r 1	A D
-------------	-----

CAUTION

When "Error 1" or an error in the middle of a self test occurs, it must be an R6561 problem, so turn OFF the power in that status and contact the nearest dealer or the sales and support office.

R6561  
DIGITAL MULTIMETER  
OPERATION MANUAL

5.3 Storage

---

5.3 Storage

When the R6561 is not used for a long period of time, wrap it with vinyl cover, etc., place it in a corrugated cardboard box, and store it in a location which is not exposed to direct sunlight. The storage temperature range is  $-25^{\circ}\text{C}$  to  $+70^{\circ}\text{C}$ .

R6561  
DIGITAL MULTIMETER  
OPERATION MANUAL

5.4 Calibration

5.4 Calibration

This section describes the method of calibrating this equipment.

Execute this calibration at least once every six months to maintain measuring accuracy.

In the R6561 system, it is possible to calibrate each range for the measurement of DC voltage, low voltage DC, and resistance by means of the key operations on the front panel or the GPIB program.

5.4.1 Preparations for Calibration

(1) Devices Required for Calibration

Devices required for the calibration are shown in Table 5-1.

In this calibration, be sure to use devices shown in this table or those equivalent or superior to these devices.

Table 5 -1 Devices Required for Calibration

Calibrating device	Range	Accuracy
Standard DC voltage generator	$\pm 100\text{mV}$ to $\pm 500\text{V}$	$\pm 100\text{mV}$ : $\pm 0.001\%$ or more $\pm 1\text{V}$ to $\pm 500\text{V}$ : $\pm 0.0005\%$ or more
DC voltage potential divider	Partial pressure ratio: 1/1000 or 1/100 Output impedance: 100 $\Omega$ or less	$\pm 0.001\%$ or more
Standard resistor	100m $\Omega$	$\pm 0.01\%$ or more
	1 $\Omega$	$\pm 0.005\%$ or more
	10 $\Omega$	
	100 $\Omega$	
	1k $\Omega$	
	10k $\Omega$	

(2) Calibration Value Tolerance Range

Table 5-2 shows the calibration value panel setting tolerance range when the calibration is made for each measuring function and range. The calibration is enabled for optional values within this range.

R6561  
DIGITAL MULTIMETER  
OPERATION MANUAL

5.4 Calibration

Table 5 - 2 Tolerance Range of each Item of Data in the Execution of EXT CAL (1 of 2)

Function	Range	ZERO / FS	Panel setting tolerance range		
			Lower limit value	Higher limit value	
VDC	1000mV	ZERO	-10mV	10mV	
		F.S	800mV	1200mV	
	10V	ZERO	-0.1V	0.1V	
		+F.S	8V	12V	
		-F.S	-8V	-12V	
	100V	ZERO	-1V	1V	
		F.S	80V	120V	
	500V	ZERO	-10V	10V	
F.S		480V	520V		
LOV DC	100μV	ZERO	-10μV	10μV	
		F.S	800μV	1200μV	
	10mV	ZERO	-0.1mV	0.1mV	
		F.S	8mV	12mV	
	100mV	ZERO	-1mV	1mV	
		F.S	80mV	120mV	
	1000mV	ZERO	-10mV	10mV	
		F.S	800mV	1200mV	
	10V	ZERO	-0.1V	0.1V	
		F.S	8V	12V	
	HIP OHM	1000mΩ	ZERO	0mΩ	
			F.S	800mΩ	1200mΩ
		10Ω	ZERO	0Ω	
			F.S	8Ω	12Ω
100Ω		ZERO	0Ω		
		F.S	80Ω	120Ω	
1000Ω		ZERO	0Ω		
		F.S	800Ω	1200Ω	
10kΩ		ZERO	0kΩ		
		F.S	8kΩ	12kΩ	

R6561  
DIGITAL MULTIMETER  
OPERATION MANUAL

5.4 Calibration

Table 5 - 2 Tolerance Range of each Item of Data in  
the Execution of EXT CAL (2 of 2)

Function	Range	ZERO FS	Panel setting tolerance range	
			Lower limit value	Higher limit value
LOP OHM	100mΩ	ZERO	0mΩ	
		F.S	80mΩ	120mΩ
	1000mΩ	ZERO	0mΩ	
		F.S	800mΩ	1200mΩ
	10Ω	ZERO	0Ω	
		F.S	8Ω	12Ω
	100Ω	ZERO	0Ω	
		F.S	80Ω	120Ω
	1000Ω	ZERO	0Ω	
		F.S	800Ω	1200Ω

(3) Power Supply and Frequency

The power supply voltage is specified as less than 90 to 110V, 103 to 132V, 198 to 242V, or 207 to 250V. Use a power supply frequency of 50Hz or 60Hz.

(4) Ambient Conditions in Calibration

Execute the calibration under the following ambient conditions:

Temperature: 23°C ±5°C  
Humidity : Less than 70% RH

Calibrate at a location free from dust, oscillation, and noise.

(5) Preheating Time

Before making the calibration, allow a preheating period of more than 60 minutes. Also, allow a specified preheating time for each device used in calibration.

(6) It is convenient to clearly mark the date of calibration and the time the next calibration with a card or sticker, etc., at the end of a calibration.



R6561  
DIGITAL MULTIMETER  
OPERATION MANUAL

5.4 Calibration

CAUTION

Connect the power cable after making sure that the POWER switch is OFF.

5.4.2 Common Operation Items and Notes

- (1) Prior to the calibration for each measurement, carryout the following operation:
  - ① Turn the EXT CAL switch on the rear panel ON.
  - ② Check that the ECAL lamp located on the lower left side of the front panel display block is lighted.
- (2) Execute the calibration in the following order:
  - ① DC voltage measurement
  - ② Low voltage DC measurement
  - ③ Resistance measurement
- (3) Full-scale calibration should be performed for both (+) and (-) for the 10V range only of the DC voltage measurement and for (+) full scale only for the others.

5.4.3 Calibration of DC Voltage Measurement

Equipment used: Standard DC voltage generator

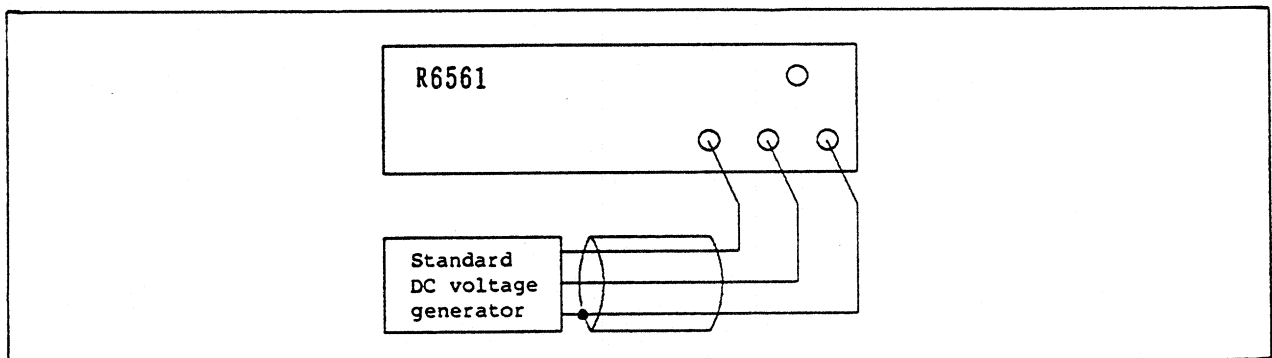

Figure 5 - 1 Calibration of DC Voltage Measurement

In this calibration of DC voltage measurement, execute both the 0-point calibration and full-scale calibration for each range.

R6561  
DIGITAL MULTIMETER  
OPERATION MANUAL

5.4 Calibration

[Calibrating Method]

- FUNCTION Setting

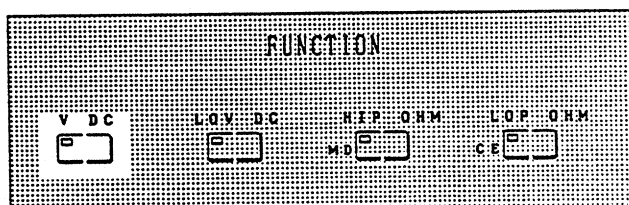

- ① Press the function Key VDC and set the FUNCTION to the DC voltage measurement.

- 10V Range Setting

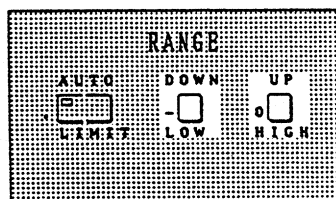

- ② Set the measuring range to 10V using the UP and DOWN keys.
- Connection of Standard DC Voltage Generator
- ③ As shown in Figure 5-1, connect the standard DC voltage generator to a point between the HI and LO pins on the lower side input terminal with the cable (MI-37) supplied with this equipment.

10V Range 0-Point Calibration

Execute the 10V range 0-point calibration according to the following procedure:

- ① Set the measuring range to 10V.
- ② Set the output of the standard DC voltage generator to 0V.
- ③ Press the SHIFT key.
- ④ press the 0 key.
- ⑤ Press the ENTER key.

0 V

0.00000 V

- When Offset Voltage Remains

[When the offset voltage remains in the generator and its output cannot be set to 0V]

When the output of the standard DC voltage generator cannot register 0V, even if set to 0V, due to an offset voltage remaining in the generator, operate it as follows:

Example: When offset voltage of 20 $\mu$ V remains

- ① Press the SHIFT key.
- ② Press .  $\square$  0  $\square$  0  $\square$  0  $\square$  2  $\square$ .
- ③ Press the ENTER key.

.00002 V

0.00002 V

R6561  
DIGITAL MULTIMETER  
OPERATION MANUAL

5.4 Calibration

(+) Full-Scale Calibration of 10V Range

Execute the (+) full-scale calibration in the 10V range according to the following procedure:

- ① Set the output of the standard DC voltage generator to 10V.
- ② Press the SHIFT key.
- ③ Press 1 □ 0 □ . □ .
- ④ Press the ENTER key.

10 V

10.00000 V

(-) Full-Scale Calibration of 10V Range

Execute the (-) full-scale calibration in the 10V range according to the following procedure:

- ① Set the output of the standard DC voltage generator to -10V.
- ② Press the SHIFT key.
- ③ Press - □ 1 □ 0 □ . □ .
- ④ Press the ENTER key.

- 10 V

-10.00000 V

R6561  
DIGITAL MULTIMETER  
OPERATION MANUAL

5.4 Calibration

- When Set Error Exists

[10V range full-scale calibration when a set error of -0.00055% is known to exist in the standard DC voltage generator]

Calibrate as follows:

- ① Set the output of the standard DC voltage generator to 10V.
- ② press the SHIFT key.
- ③ Press  $\text{9} \text{.} \text{9} \text{9} \text{9} \text{9} \text{5}$ .
- ④ Press the ENTER key.

9.99995 V

9.99995 V

1000mV Range 0-Point Calibration

Execute the 0-point calibration in 1000mV range according to the following procedure:

- ① Press the DOWN key and set the measuring range to 1000mV.
- ② Set the output of the standard DC voltage generator to 0V.
- ③ Press the SHIFT key.
- ④ Press the 0 key.
- ⑤ Press the ENTER key.

0 mV

0.000 mV

R6561  
DIGITAL MULTIMETER  
OPERATION MANUAL

5.4 Calibration

1000mV Range Full-Scale Calibration

Execute full-scale calibration in 1000mV range according to the following procedure:

- ① Set the output of the standard DC voltage to 1.0V.
- ② Press the SHIFT key.
- ③ Press 1 0 0 0 .
- ④ Press the ENTER key.

1 0 0 0 m V

1 0 0 0 . 0 0 0 m V

100V Range 0-Point Calibration

Execute the 0-point calibration in the 100V range according to the following procedure:

- ① Set the measuring range to 100V.
- ② Set the output of the standard DC voltage generator to 0V.
- ③ Press the SHIFT key.
- ④ Press the 0 key.
- ⑤ Press the ENTER key.

0 V

0 . 0 0 0 0 V

100V Range Full-Scale Calibration

Execute full-scale calibration in the 100V range according to the following procedure:

- ① Set the output of the standard DC voltage generator to 100V.
- ② Press the SHIFT key.
- ③ Press  $\square$   $\square$   $\square$ .
- ④ Press the ENTER key.

100 V

100.0000 V

500V Range 0-Point Calibration

Execute the 0-point calibration in the 500V range according to the following procedure:

- ① Set the measuring range to 500V.
- ② Set the output of the standard DC voltage generator to 0V.
- ③ Press the SHIFT key.
- ④ Press the 0 key.
- ⑤ Press the ENTER key.

0 V

0.000 V

R6561  
DIGITAL MULTIMETER  
OPERATION MANUAL

5.4 Calibration

500V Range Full-Scale Calibration

Execute the full-scale calibration in the 500V range according to the following procedure:

- ① Set the output of the standard DC voltage generator to 500V.
- ② Press the SHIFT key.
- ③ Press 5  0  0  .
- ④ Press the ENTER key.

5 0 0 V

5 0 0 . 0 0 0 V

The internal electrical component parts are heated when the 500V range is calibrated. Therefore allow time to cool down sufficiently before proceeding to the calibration of the next function.

CAUTION

[When a mistake is noticed after pressing the ENTER key]

When the 100V range full-scale is calibrated with a wrong value by mistake, re-execute the 100V range full calibration from the beginning only.



R6561  
DIGITAL MULTIMETER  
OPERATION MANUAL

5.4 Calibration

5.4.4 Calibration of Low Voltage DC Measurement

Equipment used: Standard DC voltage generator and DC voltage divider

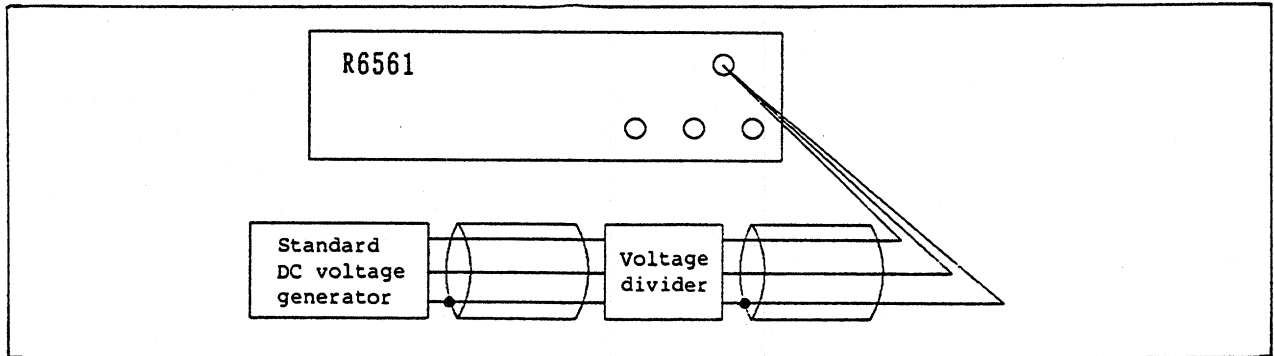

Figure 5 - 2 Calibration of Low Voltage DC Measurement (1000 $\mu$ V/10mV range)

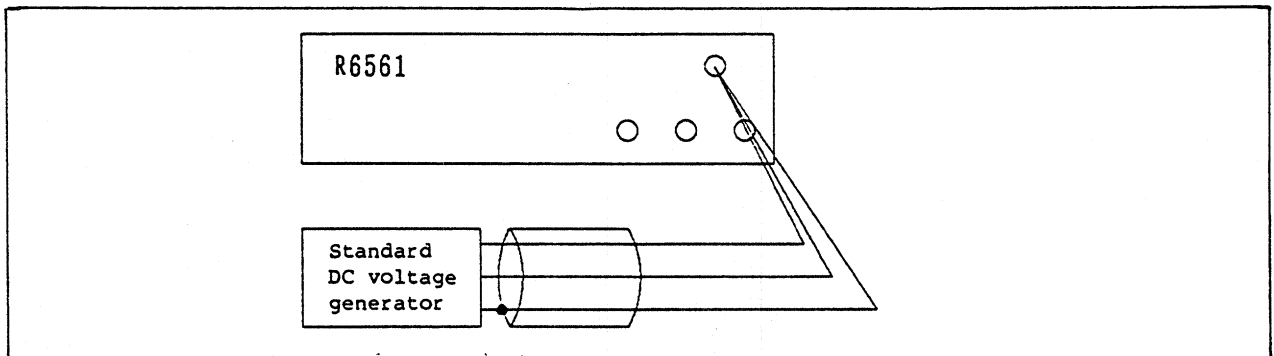

Figure 5 - 3 Calibration of Low Voltage DC Measurement (100mV to 10V range)

In this calibration of low voltage DC measurement, execute both the 0-point calibration and full scale calibration for each range.

Use a 1/1000 and a 1/100 voltage divider in the calibration of the 1000 $\mu$ V range and 10mV range respectively.

[Calibrating Method]

- FUNCTION Setting

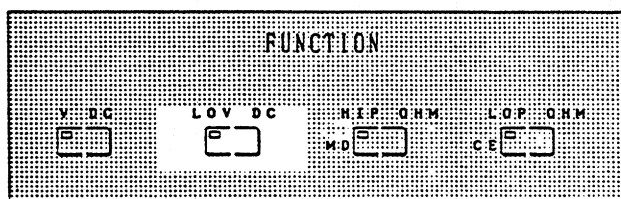

R6561  
DIGITAL MULTIMETER  
OPERATION MANUAL

5.4 Calibration

- ① Press the function key LOV DC and set the FUNCTION to the LOV DC measurement.

- 1000 $\mu$ V Range Setting

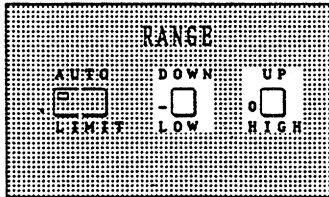

- ② Set the measuring range to 1000 $\mu$ V using the UP and DOWN keys.

- Connection of Standard DC Voltage Generator

- ③ As shown in Figure 5-2, connect the standard DC voltage generator to a point between the HI-LO terminals of the cable (A01020) supplied together with this equipment through the 1/1000 or 1/100 voltage divider.

This subsection describes the calibration procedure when the 1/1000 voltage divider is used.

1000 $\mu$ V Range 0-Point Calibration

Execute the 0-point calibration in the 1000 $\mu$ V range according to the following procedure:

- ① Set the measuring range to 1000 $\mu$ V.
- ② Set the output of the standard DC voltage generator to 0V.
- ③ Press the SHIFT key.
- ④ press the 0 key.
- ⑤ press the ENTER key.

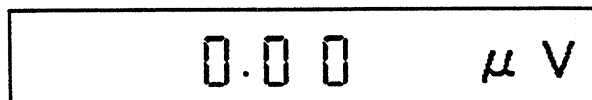
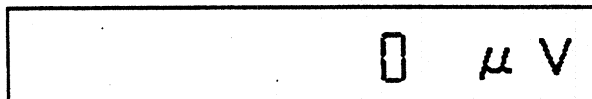

R6561  
DIGITAL MULTIMETER  
OPERATION MANUAL

5.4 Calibration

1000 $\mu$ V Range Full-Scale Calibration

Execute full-scale calibration in the 1000 $\mu$ V range according to the following procedure:

- ① Set the output of the standard DC voltage generator to 1.0.
- ② Press the SHIFT key.
- ③ Press 1  $\square$  0  $\square$  0  $\square$  0  $\square$  .
- ④ Press the ENTER key.

1 0 0 0  $\mu$  V

1 0 0 0 . 0 0  $\mu$  V

10mV Range 0-Point Calibration

Execute the 0-point calibration in the 10mV range according to the following procedure:

- ① Set the measuring range to 10mV.
- ② Set the output of the standard DC voltage generator to 0V.
- ③ Press the SHIFT key.
- ④ Press the 0 key.
- ⑤ Press the ENTER key.

0 m V

0 . 0 0 0 0 0 m V

R6561  
DIGITAL MULTIMETER  
OPERATION MANUAL

5.4 Calibration

10mV Range Full-Scale Calibration

Execute the full-scale calibration in the 10mV range according to the following procedure:

- ① Set the output of the standard DC voltage generator to 10V.
- ② Press the SHIFT key.
- ③ Press numeric keys in the order of 1 and 0.
- ④ Press the ENTER key.

10 mV

10.000000 mV

- Connection of Standard DC Voltage Generator

As shown in Figure 5-3, remove the voltage divider and connect the standard DC voltage generator to a point between the HI and LO terminals of the cable (A01020) supplied together with this equipment.

100mV Range 0-Point Calibration

Execute the 0-point calibration in the 100mV range according to the following procedure:

- ① Set the measuring range to 100mV using the UP and DOWN keys.
- ② Set the output of the standard DC voltage generator to 0V.
- ③ Press the SHIFT key.
- ④ press the 0 key.
- ⑤ Press the ENTER key.

0 mV

0.00000 mV

100mV Range Full-Scale Calibration

Execute full-scale calibration in the 100mV range according to the following procedure:

- ① Set the output of the standard DC voltage generator to 100mV.
- ② Press the SHIFT key.
- ③ press the numeric keys in the order of 1, 0, and 0.
- ④ press the ENTER key.

1 0 0 m V

1 0 0 . 0 0 0 0 m V

100mV Range 0-Point Calibration

Execute the 0-point calibration in the 1000mV range according to the following procedure:

- ① Press the UP key and set the measuring range to 1000mV.
- ② Set the output of the standard DC voltage generator to 0V.
- ③ Press the SHIFT key.
- ④ Press the 0 key.
- ⑤ Press the ENTER key.

0 m V

0 . 0 0 0 m V

R6561  
DIGITAL MULTIMETER  
OPERATION MANUAL

5.4 Calibration

1000mV Full-Scale Calibration

Execute full-scale calibration in the 1000mV range according to the following procedure:

- ① Set the output of the standard DC voltage generator to 1.0V.
- ② Press the SHIFT key.
- ③ Press 1 0 0 0 .
- ④ Press ENTER key.

1 0 0 0 m V

1 0 0 0 . 0 0 0 m V

10V Range 0-Point Calibration

Execute the 0-point calibration in the 10V range according to the following procedure:

- ① Set the measuring range to 10V.
- ② Set the output of the standard DC voltage generator to 0V.
- ③ Press the SHIFT key.
- ④ press the 0 key.
- ⑤ Press the ENTER key.

0 V

0 . 0 0 0 0 0 V

R6561  
DIGITAL MULTIMETER  
OPERATION MANUAL

5.4 Calibration

10V Range Full-Scale Calibration

Execute the full scale calibration in the 10V range according to the following procedure:

- ① Set the output of the standard DC voltage generator to 10V.
- ② Press the SHIFT key.
- ③ Press  $\square$   $\square$  .
- ④ Press the NETER key.

10 V

10.00000 V

CAUTION

[When a mistake is noticed after pressing the ENTER key]

When the 1000mV range full scale is calibrated with a wrong value by mistake, for instance, re-execute the 1000mV full-scale calibration from the beginning only.

R6561  
DIGITAL MULTIMETER  
OPERATION MANUAL

5.4 Calibration

5.4.5 Calibration of Resistance Measurement

Execute the calibration for both the HI-P mode resistance measurement and LO-P mode resistance measurement.

Equipment used: Standard resistor

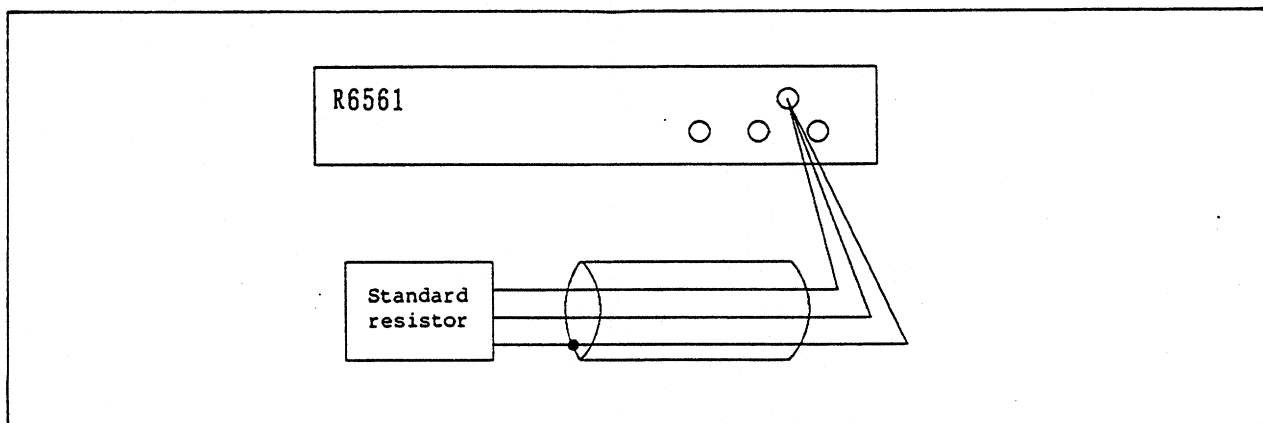

Figure 5 - 4 Calibration of Resistance Measurement

In this calibration of resistance measurement, execute both the 0-point calibration and full-scale calibration for each measuring range in both the HI-P mode and LO-P mode.

Calibration of either of these two modes may be done first.

[Calibrating Method]

- FUNCTION Setting

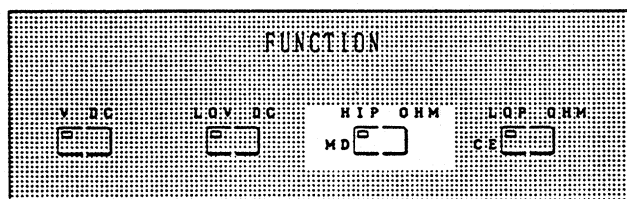

- ① Press the HIP OHM function key and set the FUNCTION to the HI-P mode resistance measurement.



R6561  
DIGITAL MULTIMETER  
OPERATION MANUAL

5.4 Calibration

- 1000m $\Omega$  Range Setting

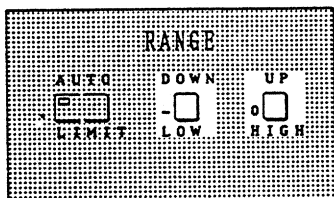

- ② Set the measuring range to 1000m $\Omega$  using the UP and DOWN keys.

- Connection of Standard Resistor

- ③ As shown in Figure 5-4, connect the cable (A01004) supplied together with this equipment to the upper side input terminal.
- ④ When the 0-point is calibrated in one range in this resistance measurement, the calibration is executed for all ranges at one time.

0-Point Calibration

Execute the 0-point calibration for all ranges according to the following procedure:

- ① Short the clip at the tip of the cable.
- ② Press the SHIFT key.
- ③ Press the 0 key.
- ④ press the ENTER key.

0 m  $\Omega$

0.000 m  $\Omega$

R6561  
DIGITAL MULTIMETER  
OPERATION MANUAL

5.4 Calibration

1000m $\Omega$  Range Full-Scale Calibration

Execute the full-scale calibration at 1000m $\Omega$  according to the following procedure:

- ① Set the measuring range to 1000m $\Omega$ .
- ② Connect the standard 1000m $\Omega$  resistor to the measuring equipment.
- ③ Press the SHIFT key.
- ④ Press  $\square \square \square \square \cdot$ .
- ⑤ Press the ENTER key.

1 0 0 0 m  $\Omega$

1 0 0 0 . 0 0 0 0 m  $\Omega$

10 $\Omega$  Range Full-Scale Calibration

Execute the full-scale calibration at 10 $\Omega$  according to the following procedure:

- ① Set the measuring range to 10 $\Omega$
- ② Connect the standard 10 $\Omega$  resistor to the measuring equipment.
- ③ Press the SHIFT key.
- ④ Press  $\square \square \cdot$ .
- ⑤ Press the ENTER key.

1 0  $\Omega$

1 0 . 0 0 0 0 0 0  $\Omega$

100Ω Range Full-Scale Calibration

Execute the full-scale calibration in the 100Ω range according to the following procedure:

- ① Set the measuring range to 100Ω.
- ② Connect the standard 100Ω resistor to the measuring equipment.
- ③ Press the SHIFT key.
- ④ Press 1□ 0□ 0□ .
- ⑤ Press the ENTER key.

100 Ω

100.0000 Ω

1000Ω Range Full-Scale Calibration

Execute the full-scale calibration in the 1000Ω range according to the following procedure:

- ① Set the measuring range to 1000Ω.
- ② Connect the standard 1000Ω resistor to the measuring equipment.
- ③ Press the SHIFT key.
- ④ Press 1□ 0□ 0□ 0□ .
- ⑤ Press the ENTER key.

1000 Ω

1000.0000 Ω

R6561  
DIGITAL MULTIMETER  
OPERATION MANUAL

5.4 Calibration

10k $\Omega$  Range Full-Scale Calibration

Execute the full scale calibration in the 10k $\Omega$  range according to the following procedure:

- ① Set the measuring range to 10k $\Omega$ .
- ② Connect the standard 10k $\Omega$  resistor to the measuring equipment.
- ③ Press the SHIFT key.
- ④ Press 1  0  .
- ⑤ Press the ENTER key.

10 k  $\Omega$

10.0000 k  $\Omega$

(2) Calibration of LO-P Mode Resistance Measurement

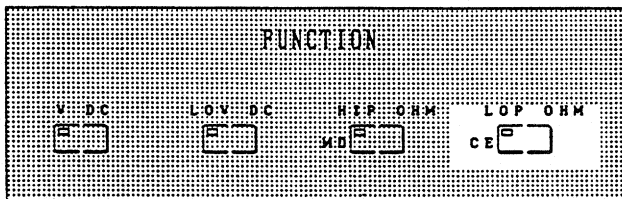

- ① Press the function key LOP OHM and set the FUNCTION to the LO-P mode resistance measurement.

R6561  
DIGITAL MULTIMETER  
OPERATION MANUAL

5.4 Calibration

- 100mΩ Range Setting

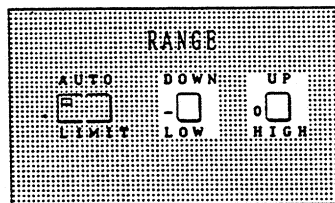

- ② Set the measuring range to 100mΩ using the UP and DOWN keys.

- Connection of Standard Resistor

- ③ As shown in Figure 5-4, connect the cable (A01004) supplied together with this equipment to the upper side input terminal.
- ④ When the 0-point is calibrated in one range, the calibration is executed for all ranges at one time in this calibration of resistance measurement.

0-Point Calibration

Execute the 0-point calibration for all ranges according to the following procedure:

- ① Short the clip at the tip of the cable.
- ② Press the SHIFT key.
- ③ Press the 0 key.
- ④ Press the ENTER key.

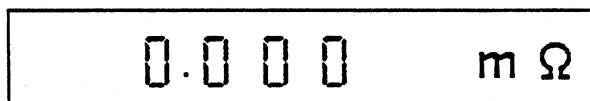
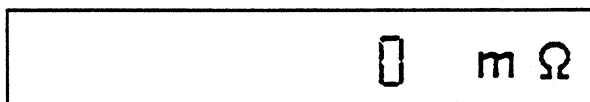

100mΩ Range Full-Scale Calibration

Execute full-scale calibration in the 100mΩ range according to the following procedure:

- ① Set the measuring range to 100mΩ.
- ② Connect the standard 100mΩ resistor to the measuring equipment.
- ③ Press the SHIFT key.
- ④ Press  $\square$   $\square$   $\square$ .
- ⑤ Press the ENTER key.

100 mΩ

100.000 mΩ

1000mΩ Range Full-Scale Calibration

Execute full-scale calibration in the 1000mΩ range according to the following procedure:

- ① Set the measuring range to 1000mΩ.
- ② Connect the standard 1000mΩ resistor to the measuring equipment.
- ③ Press the SHIFT key.
- ④ Press  $\square$   $\square$   $\square$   $\square$ .
- ⑤ Press the ENTER key.

1000 mΩ

1000.00 mΩ



R6561  
DIGITAL MULTIMETER  
OPERATION MANUAL

5.4 Calibration

1000 $\Omega$  Range Full-Scale Calibration

Execute full-scale calibration in the 1000 $\Omega$  range according to the following procedure:

- ① Set the measuring range to 1000 $\Omega$ .
- ② Connect the standard 1000 $\Omega$  resistor to the measuring equipment.
- ③ Press the SHIFT key.
- ④ Press:     .
- ⑤ Press the ENTER key.

1 0 0 0  $\Omega$

1 0 0 0 . 0  $\Omega$

CAUTION

[When mistake is noticed after pressing the ENTER key]

When the 1000 $\Omega$  range full-scale calibration is executed with a wrong value, for instance, re-execute the 1000 $\Omega$  range full-scale calibration from the beginning only.



R6561  
DIGITAL MULTIMETER  
OPERATION MANUAL

6.1 Measuring Function

6. SPECIFICATION

6.1 Measuring Function

(1) DV Voltage Measurement

[Range, maximum display, maximum resolution, input impedance, and maximum input voltage]

Range	6-1/2 digit display		5-1/2 digit display		4-1/2 digit display	
	Maximum display	Maximum resolution	Maximum display	Maximum resolution	Maximum display	Maximum resolution
1000mV	1199.999mV	1 $\mu$ V	1199.99mV	10 $\mu$ V	1199.9mV	100 $\mu$ V
10V	11.99999V	10 $\mu$ V	11.9999V	100 $\mu$ V	11.999V	1mV
100V	119.9999V	100 $\mu$ V	119.999V	1mV	119.99V	10mV
500V	519.999V	1mV	519.99V	10mV	519.9V	100mV

Range	Input impedance	Input bias current	Maximum input voltage		
			Between HI and LO terminals	Between GUARD and chassis	Between GUARD and LO terminal
1000mV	More than 10 <sup>10</sup> $\Omega$	Less than 20 PA (at 23 )	$\pm$ 600V Peak continuous	$\pm$ 500V Peak continuous	$\pm$ 50V Peak continuous
10V					
100V	10M $\Omega$ $\pm$ 0.5%				
500V					

R6561  
DIGITAL MULTIMETER  
OPERATION MANUAL

6.1 Measuring Function

[Measuring Accuracy]

This is the value indicated with  $\pm$  (a percentage of reading + digit) when the AUTO ZERO and AUTO CALIBRATION (where the interval of calibration time is assumed to be less than one hour) is set to ON.

Measuring Accuracy in 6-1/2 digit Display

Integrate time (IT)	Range	Measuring accuracy		
		24 hours (23°C $\pm$ 1°C)	90 days (23°C $\pm$ 5°C)	180 days (23°C $\pm$ 5°C)
1PLC	1000mV	0.002 + 6	0.004 + 7	0.005 + 7
	10V	0.0018 + 4	0.0035 + 4	0.0045 + 4
	100V	0.002 + 5	0.0042 + 6	0.0052 + 6
	500V	0.002 + 4	0.004 + 4	0.005 + 4
5PLC to 100PLC	1000mV	0.002 + 5	0.004 + 6	0.005 + 6
	10V	0.0018 + 3	0.0035 + 3	0.0045 + 3
	100V	0.002 + 4	0.0042 + 5	0.0052 + 5
	500V	0.002 + 3	0.004 + 3	0.005 + 3

Measuring Accuracy in 5-1/2 digit Display

Integrate time (IT)	Range	Measuring accuracy		
		24 hours (23°C $\pm$ 1°C)	90 days (23°C $\pm$ 5°C)	180 days (23°C $\pm$ 5°C)
1PLC	1000mV	Take the digit term of this measuring accuracy as one-tenth of that of the 6-1/2 digit display.		
	10V			
	100V			
	500V			
5PLC to 100PLC	1000mV	Take the digit term of this measuring accuracy as one-tenth of that of the 6-1/2 digit display.		
	10V			
	100V			
	500V			

R6561  
DIGITAL MULTIMETER  
OPERATION MANUAL

6.1 Measuring Function

Measuring Accuracy in 4-1/2 digit Display

Integrate time (IT)	Range	Measuring accuracy		
		24 hours (23°C ±1°C)	90 days (23°C ±5°C)	180 days (23°C ±5°C)
1PLC	1000mV	Take the digit term of this measuring accuracy as one-hundredth of that of the 6-1/2 digit display.		
	10V			
	100V			
	500V			
5PLC to 100PLC	1000mV	Take the digit term of this measuring accuracy as one-hundredth of that of the 6-1/2 digit display.		
	10V			
	100V			
	500V			

[Temperature Coefficient]

This is the value indicated with ± (a percentage of reading + digit)/°C in a temperature range from 0°C to 40°C.

Range	6-1/2 digit display	5-1/2 digit display	4-1/2 digit display
1000mV	0.0004 + 0.3	0.0004 + 0.03	0.0004 + 0.003
10V	0.0003 + 0.1	0.0003 + 0.01	0.0003 + 0.001
100V	0.0004 + 0.3	0.0004 + 0.03	0.0004 + 0.003
500V	0.0004 + 0.1	0.0004 + 0.01	0.0004 + 0.001

[Noise Rejection]

At an impedance of 1kΩ imbalance between DUARD and LO terminals

Effective CMR		NMR
50/60Hz ±0.09%	DC	50/60Hz ±0.09%
160dB	140dB	60dB

[Measuring Speed]

35 times/sec. (Integrate time: 1 PLC and, AUTO ZERO: ON)

R6561  
DIGITAL MULTIMETER  
OPERATION MANUAL

6.1 Measuring Function

(2) Low Voltage DC Measurement

[Range, maximum display, maximum resolution, input impedance, maximum allowable signal source resistance, and maximum input voltage]

Range	6-1/2 digit display		5-1/2 digit display		4-1/2 digit display	
	Maximum display	Maximum resolution	Maximum display	Maximum resolution	Maximum display	Maximum resolution
1000 $\mu$ V	-	-	1199.99 $\mu$ V	10nV	1199.9 $\mu$ V	100nV
10mV	11.99999mV	10nV	11.9999mV	100nV	11.999mV	1 $\mu$ V
100mV	119.9999mV	100nV	119.999mV	1 $\mu$ V	119.99mV	10 $\mu$ V
1000mV	1199.999mV	1 $\mu$ V	1199.99mV	10 $\mu$ V	1199.9mV	100 $\mu$ V
10V	11.99999V	10 $\mu$ V	11.9999V	100 $\mu$ V	11.999V	1mV

Range	Input impedance	Maximum allowable signal source resistance	Maximum input voltage		
			Between HI and LO terminals	Between GUARD and chassis	Between GUARD and LO terminal
1000 $\mu$ V	More than $10^8 \Omega$	100 $\Omega$	$\pm 30$ V Peak continuous	$\pm 500$ V Peak continuous	$\pm 50$ V Peak continuous
10mV					
100mV	More than $10^9 \Omega$	1k $\Omega$			
1000mV	More than $10^{10} \Omega$	-			
10V					

R6561  
DIGITAL MULTIMETER  
OPERATION MANUAL

6.1 Measuring Function

[Measuring Accuracy]

This is the value after making a zero-adjustment by the ZERO ADJ key to be indicated with  $\pm$  (a percentage of reading + digit) when the AUTO ZERO and AUTO CALIBRATION (where the interval of calibration time is assumed to be less than one hour) are set to ON.

Measuring Accuracy in 6-1/2 digit Display

Integrate time (IT)	Range	Measuring accuracy		
		24 hours (23°C ±1°C)	90 days (23°C ±5°C)	180 days (23°C ±5°C)
5PLC 10PLC	10mV	0.005 + 15	0.008 + 15	0.009 + 15
	100mV	0.003 + 8	0.005 + 8	0.006 + 8
	1000mV	0.002 + 6	0.004 + 6	0.005 + 6
	10V	0.0018 + 4	0.0035 + 4	0.0045 + 4
20PLC 50PLC 100PLC	10mV	0.005 + 10	0.008 + 10	0.009 + 10
	100mV	0.003 + 5	0.005 + 5	0.006 + 5
	1000mV	0.002 + 5	0.004 + 5	0.005 + 5
	10V	0.0018 + 3	0.0035 + 3	0.0045 + 3

Measuring Accuracy in 5-1/2 digit Display

Integrate time (IT)	Range	Measuring accuracy		
		24 hours (23°C ±1°C)	90 days (23°C ±5°C)	180 days (23°C ±5°C)
5PLC 10PLC	1000μV	0.005 + 15	0.008 + 15	0.009 + 15
	10mV	Take the digit term of this measuring accuracy as one-tenth of that of the 6-1/2 digit display.		
	100mV			
	1000mV			
	10V			
20PLC 50PLC 100PLC	1000μV	0.005 + 10	0.008 + 10	0.009 + 10
	10mV	Take the digit term of this measuring accuracy as one-tenth of that of the 6-1/2 digit display.		
	100mV			
	1000mV			
	10V			

R6561  
DIGITAL MULTIMETER  
OPERATION MANUAL

6.1 Measuring Function

Measuring Accuracy in 4-1/2 digit Display

Integrate time (IT)	Range	Measuring accuracy		
		24 hours (23°C ±1°C)	90 days (23°C ±5°C)	180 days (23°C ±5°C)
5PLC 10PLC	1000μV	Take the digit term of this measuring accuracy as one-tenth of that of the 5-1/2 digit display.		
	10mV	Take the digit term of this measuring accuracy as one-hundredth of that of the 6-1/2 digit display.		
	100mV			
	1000mV			
10V				
20PLC 50PLC 100PLC	1000μV	Take the digit term of this measuring accuracy as one-tenth of that of the 5-1/2 digit display.		
	10mV	Take the digit term of this measuring accuracy as one-hundredth of that of the 6-1/2 digit display.		
	100mV			
	1000mV			
10V				

[Temperature Coefficient]

A value in a temperature range from 0°C to 40°C is indicated with ± (a percentage of reading + digit)/°C, the which ±100nV/°C (temperature difference between HI and LO terminals) is added.

Range	6-1/2 digit display	5-1/2 digit display	4-1/2 digit display
1000μV	-	0.0005 + 3	0.0005 + 0.3
10mV	0.0005 + 3	0.0005 + 0.3	0.0005 + 0.03
100mV	0.0004 + 1	0.0004 + 0.1	0.0004 + 0.01
1000mV	0.0004 + 0.3	0.0004 + 0.03	0.0004 + 0.003
10V	0.0004 + 0.1	0.0004 + 0.01	0.0004 + 0.001

R6561  
DIGITAL MULTIMETER  
OPERATION MANUAL

6.1 Measuring Function

[Zero stability]

±50nV/day

[Noise Rejection]

4 times/sec. (Integrate time: 5PLC, and AUTO ZERO: OFF)

(3) Resistance Measurement

[Range, maximum display, maximum resolution, measuring current, maximum power consumption, and maximum voltage between open terminals]

(1 of 2)

Function	Range	6-1/2 digit display		5-1/2 digit display	
		Maximum display	Maximum resolution	Maximum display	Maximum resolution
HIP OHM	1000mΩ	1199.999mΩ	1μΩ	1199.99mΩ	10μΩ
	10Ω	11.99999Ω	10μΩ	11.9999Ω	100μΩ
	100Ω	119.9999Ω	100μΩ	119.999Ω	1mΩ
	1000Ω	1199.999Ω	1mΩ	1199.99Ω	10mΩ
	10kΩ	-	-	11.9999Ω	100mΩ
LOP OHM	100mΩ	-	-	119.999mΩ	1μΩ
	1000mΩ	-	-	1199.99mΩ	10μΩ
	10Ω	-	-	11.9999kΩ	100μΩ
	100Ω	-	-	119.999Ω	1mΩ
	1000Ω	-	-	-	-

R6561  
DIGITAL MULTIMETER  
OPERATION MANUAL

6.1 Measuring Function

(2 of 2)

Function	Range	4-1/2 digit display		Measuring current	Maximum power consumption	Maximum voltage between open terminals
		Maximum display	Maximum resolution			
HIP OHM	1000m $\Omega$	1199.9m $\Omega$	100 $\mu\Omega$	10mA	100 $\mu$ W	Less than 1V
	10 $\Omega$	11.999 $\Omega$	1m $\Omega$	10mA	1mW	
	100 $\Omega$	119.99 $\Omega$	10m $\Omega$	1mA	100 $\mu$ W	
	1000 $\Omega$	1199.9 $\Omega$	100m $\Omega$	100 $\mu$ A	10 $\mu$ W	
	10k $\Omega$	11.999k $\Omega$	1 $\Omega$	10 $\mu$ A	1 $\mu$ W	
LOP OHM	100m $\Omega$	119.99m $\Omega$	10 $\mu\Omega$	10mA	10 $\mu$ W	Less than 20mV
	1000m $\Omega$	1199.9m $\Omega$	100 $\mu\Omega$	1mA	1 $\mu$ W	
	10 $\Omega$	11.999 $\Omega$	1m $\Omega$	100 $\mu$ A	100nW	
	100 $\Omega$	11.999 $\Omega$	10m $\Omega$	10 $\mu$ A	10nW	
	1000 $\Omega$	1199.9 $\Omega$	100m $\Omega$	1 $\mu$ A	1nW	

[Maximum Input Voltage]

Between HI and LO terminals :  $\pm 30$ V peak, continuous  
 Between GURAD and chassis :  $\pm 500$ V peak, continuous  
 Between GUARD and LO terminal:  $\pm 50$ V peak, continuous



R6561  
DIGITAL MULTIMETER  
OPERATION MANUAL

6.1 Measuring Function

[Measuring Accuracy]

This is the value after making a zero-adjustment by the ZERO ADJ key to be indicated with  $\pm$  (a percentage of reading + digit) when the AUTO ZERO and AUTO CALIBRATION (where the interval of calibration time taken is assumed to be less than one hour) are set to ON.

Measuring Accuracy in HI-P Mode of 6-1/2 digit Display

Integrate time (IT)	Range	Measuring accuracy		
		24 hours (23°C $\pm$ 1°C)	90 days (23°C $\pm$ 5°C)	180 days (23°C $\pm$ 5°C)
5PLC 10PLC	100m $\Omega$	0.012 + 20	0.017 + 20	0.02 + 20
	10 $\Omega$	0.008 + 8	0.012 + 8	0.015 + 8
	100 $\Omega$			
	1000 $\Omega$			
20PLC 50PLC 100PLC	1000m $\Omega$	0.012 + 15	0.017 + 15	0.02 + 15
	10 $\Omega$	0.008 + 5	0.012 + 5	0.015 + 5
	100 $\Omega$			
	1000 $\Omega$			

Measuring Accuracy in HI-P Mode of 5-1/2 digit Display

Integrate time (IT)	Range	Measuring accuracy		
		24 hours (23°C $\pm$ 1°C)	90 days (23°C $\pm$ 5°C)	180 days (23°C $\pm$ 5°C)
5PLC 10PLC	1000m $\Omega$	Take the digit term of the measuring accuracy as one-tenth of that of the 6-1/2 digit display.		
	10 $\Omega$			
	100 $\Omega$			
	1000 $\Omega$			
	10k $\Omega$	0.008 + 6	0.0012 + 6	0.015 + 6
20PLC 50PLC 100PLC	1000 $\mu\Omega$	Take the digit term of the measuring accuracy as one-tenth of that of the 6-1/2 digit display.		
	10 $\Omega$			
	100 $\Omega$			
	1000 $\Omega$			
	10k $\Omega$	0.008 + 5	0.0012 + 5	0.015 + 5

R6561  
DIGITAL MULTIMETER  
OPERATION MANUAL

6.1 Measuring Function

**Measuring Accuracy in HI-P Mode of 4-1/2 digit Display**

Integrate time (IT)	Range	Measuring accuracy		
		24 hours (23°C ±1°C)	90 days (23°C ±5°C)	180 days (23°C ±5°C)
5PLC 10PLC	1000mΩ	Take the digit term of this measuring accuracy as one-hundredth of that of the 6-1/2 digit display.		
	10Ω			
	100Ω			
	1000Ω			
	10kΩ	Take the digit term of this measuring accuracy as one-tenth of that of the 5-1/2 digit display.		
20PLC 50PLC 100PLC	1000mΩ	Take the digit term of this measuring accuracy as one-hundredth of that of the 6-1/2 digit display.		
	10Ω			
	100Ω			
	1000Ω			
	10kΩ	Take the digit term of this measuring accuracy as one-tenth of that of the 5-1/2 digit display.		

**Measuring Accuracy in LO-P Mode of 5-1/2 digit Display**

Integrate time (IT)	Range	Measuring accuracy		
		24 hours (23°C ±1°C)	90 days (23°C ±5°C)	180 days (23°C ±5°C)
5PLC 10PLC	100mΩ	0.02 + 20	0.025 + 20	0.03 + 20
	1000mΩ	0.015 + 15	0.02 + 15	0.025 + 15
	10Ω	0.01 + 15	0.015 + 15	0.02 + 15
	100Ω			
20PLC 50PLC 100PLC	100mΩ	0.02 + 15	0.025 + 15	0.03 + 15
	1000mΩ	0.015 + 10	0.02 + 10	0.025 + 10
	10Ω	0.01 + 10	0.015 + 10	0.02 + 10
	100Ω			

R6561  
DIGITAL MULTIMETER  
OPERATION MANUAL

6.1 Measuring Function

**Measuring Accuracy in LO-P Mode of 4-1/2 digit Display**

Integrate time (IT)	Range	Measuring accuracy		
		24 hours (23°C ±1°C)	90 days (23°C ±5°C)	180 days (23°C ±5°C)
5PLC 10PLC	100mΩ	Take the digit term of this measuring accuracy as one-tenth of that of the 5-1/2 digit display.		
	1000mΩ			
	10Ω			
	100Ω			
	1000Ω	0.01 + 10	0.015 + 10	0.02 + 10
20PLC 50PLC 100PLC	100mΩ	Take the digit term of this measuring accuracy as one-tenth of that of the 5-1/2 digit display.		
	1000mΩ			
	10Ω			
	100Ω			
	1000Ω	0.01 + 5	0.015 + 5	0.02 + 5

[Temperature Coefficient]

This is a value in which the reading term and digit term of the measuring accuracy for 90 days are taken as one-tenth, respectively, where the integrate time is assumed to be 5 PLC in both the HI-P mode and LO-P mode in a temperature range from 0°C to +40°C.

[Measuring Speed]

Once every second (Integrate time: 5 PLC)

R6561  
DIGITAL MULTIMETER  
OPERATION MANUAL

6.2 Integrate Time

---

6.2 Integrate Time

The integrate time can be set to six cycles as follows: (Of these cycles 1PLC is set to DC voltage measurement only.)

1PLC, 5PLC, 10PLC, 20PLC, 50PLC, 100PLC

PLC (Power Line Cycle)

50Hz 1PLC=20ms

60Hz 1PLC ≈ 16.7ms

6.3 Null Function

Measure the null value when the null function is set to ON from OFF, and in subsequent measurements, subtract the null value from each measured value. The correction range is ±1% of each range.

6.4 Smoothing Function

This is a function to obtain a moving average of a specified number of measuring times from measurement data to execute a digital like filtering function.

6.5 Sampling Mode

RUN : Continues the sampling continuously.

HOLD: Executes the sampling once only for the input of the trigger signal.

6.6 Computing Function

6.6.1 Primary Computing Function

The following computation can be made for the measured value D (where X, Y, and D are all constants):

(1) Scaling

$$R = \frac{D - Y}{X} \times Z$$

(2) % Deviation

$$R = \frac{D - X}{|X|} \times 100 (\%)$$

(3) Delta

$$R (\Delta D) = D_t - D_{t-1}$$

(Difference with the data of one previous sampling)

(4) Multiply

$$R = D_t \times D_{t-1}$$

(Multiplication with the data of one previous sampling)

(5) Decibel

$$R (\text{dB}) = 20 Y \log \left| \frac{D}{X} \right|$$

(6) Effective Value (RMS)

$$R = \sqrt{\frac{1}{X} \sum_{K=1}^X D_k^2}$$

(7) dBm

$$R (\text{dBm}) = 10 \log \frac{D^2/X}{1\text{mW}}$$

D: Voltage measurement value

Set the reference resistance value to constant X and convert the measured voltage for a reference resistance into a dBm value with 1mW = 0 (dBm) taken as a standard value.

R6561  
DIGITAL MULTIMETER  
OPERATION MANUAL

6.6 Computing Function

(8) Resistance Value Temperature Correction

$$R_{20} = \frac{R_x}{1 + 0.00393 \times (X - 20)} \times \frac{1000}{Y} \quad [\Omega/\text{km}]$$

R<sub>20</sub>: Resistance value of a cable converted to the value at 20°C  
[Ω/km]

R<sub>x</sub>: Resistance measurement value at a room temperature of X°C [Ω]

X: Room temperature when measured [°C]

Y: Length of a measured cable [m]

6.6.2 Secondary Computing Function

A secondary computation can be made on measurement data and on the data after making the primary computation (where N is a constant).

(1) Comparator 1

R(H2) : HIGH 2 < D  
R(H1) : HIGH 1 < D ≤ HIGH 2  
R(PASS) : LOW 1 ≤ D ≤ HIGH 1  
R(L1) : LOW 2 ≤ D < LOW 1  
R(L2) : D < LOW 2

(2) Comparator 2

R(H2) : (LIMIT + %2) < D  
R(H1) : (LIMIT + %1) < D ≤ (LIMIT + %2)  
R(PASS) : (LIMIT - %1) ≤ D ≤ (LIMIT + %1)  
R(L1) : (LIMIT - %2) ≤ D < (LIMIT - %1)  
R(L2) : D < (LIMIT - %2)

(3) Statistical Computation

R(MAX) : Maximum value of N times of measurement  
R(MIN) : Minimum value of N times of measurement

$$R(\text{AVE}) : \frac{1}{N} \times \sum_{K=1}^N D_k$$

$$R(\text{P-P}) : \frac{|R(\text{MAX}) - R(\text{MIN})|}{N}$$

$$R(\sigma) : R = \sqrt{\frac{1}{N-1} \times \sum_{K=1}^N (D_k - \bar{D})^2}$$

R(UCL) : R(AVE) + 3R(σ)

R(LCL) : R(AVE) - 3R(σ)

R(COUNT): Sample size N

R6561  
DIGITAL MULTIMETER  
OPERATION MANUAL

6.7 Input/Output Function

6.7 Input/Output Function

Trigger input signal:

The measurement start signal can be input from connector BNC or the rear panel

TTL negative pulse (Pulse width: more than 100 $\mu$ s)

Complete output signal:

The complete signal is output from the connector BNC when the measurement ends.

TTL negative pulse (Pulse width: approx. 130 $\mu$ s)

GPIB interface:

Conformable standard: IEEE 488-1978

Output data format : ASCII format

Interface function : SH1, AH1, T5, L4, SR1, RL1, PP0, DC1, DT1, C0, E2

Remote programming : Control of all functions of control panel switches (excluding POWER switch, LO-GUARD SHORT switch, and ZERO ADJ key switch)

Analog output : Output voltage: 0 to 0.999V  
Output mode and conversion output

Output mode	Conversion output
OFF	0V
Low order three digits of displayed value	Digital display 000 to 500 to 999 Analog output 0.000 to 0.500 to 0.999V
Low order three digits of displayed value +OFFSET (500)	Digital display -500 to 000 to 499 Analog output 0.000 to 0.500 to 0.999V
Low order two digits of displayed value	Digital display 00 to 50 to 99 Analog output 0.000 to 0.500 to 0.999V
Low order two digits of displayed value +OFFSET (50)	Digital display -50 to 00 to 49 Analog output 0.000 to 0.500 to 0.990V

Conversion accuracy :  $\pm 0.3\%$  of F.S.  
(For 180 days at 23 $^{\circ}$ C  $\pm 5^{\circ}$ C and at 85% RH)

Output impedance : Approx. 600 $\Omega$   
Output terminal : Connector BNC

R6561  
DIGITAL MULTIMETER  
OPERATION MANUAL

6.8 General Specifications

6.8 General Specifications

- Measuring system : Integrating system
- Input system : Floated and guarded system
- Input terminal : Binding post (for DC current measurement)  
6P round type connector (for low voltage DC and resistance measurement)
- Range selection : Manual/Automatic/Remote
- Data display : 7-segment green LED
- Polarity display : (-) polarity display
- Unit display : 5 x 7 dot matrix LED
- Buzzer function : Can be set ON/OFF  
When set to ON, the buzzer is activated in the following cases:  
- Occurrence of an error  
- Input of a panel key  
- Execution of comparator computation  
- When any other special event occurs
- Error display : When an error occurs in a measurement, computation, parameter setting, and a self test, an error code corresponding to the details of the error is displayed in the display block.
- Software calibration : Possible to execute the calibration for each function and range of DC voltage/low voltage DC/resistance measurement.
- Preheating time : Approx. 60 minutes
- Ambient conditions : Temperature: 0°C to +40°C  
Humidity : less than 85% RH
- Storage temperature range: -25°C to +70°C
- Supply voltage : (To be set as specified when ordered)

Option No.	Standard	32	42	44
Supply voltage (V)	90 to 110	103 to 132	198 to 242	207 to 250



R6561  
DIGITAL MULTIMETER  
OPERATION MANUAL

6.8 General Specifications

---

Power supply frequency : 48 to 66Hz  
Power consumption : Less than 33VA  
External dimensions : Approx. 240(W) x 132(H) x 400(D) mm  
Weight : Less than 7.0kg



R6561  
DIGITAL MULTIMETER  
OPERATION MANUAL

7.1 Outline

7. FUNCTIONAL DESCRIPTION

7.1 Outline

Various types of data can be processed as required by the integrated microcomputers of this equipment. The results of measurement are output to each output system (display, GPIB, and analog output). This chapter outlines such an operation performed by this equipment by means of two diagrams.

Figure 7-1 is a conceptual diagram of the operation of this equipment from the occurrence of measuring data to the output of this data. Figure 7-2 is a block diagram of this equipment.

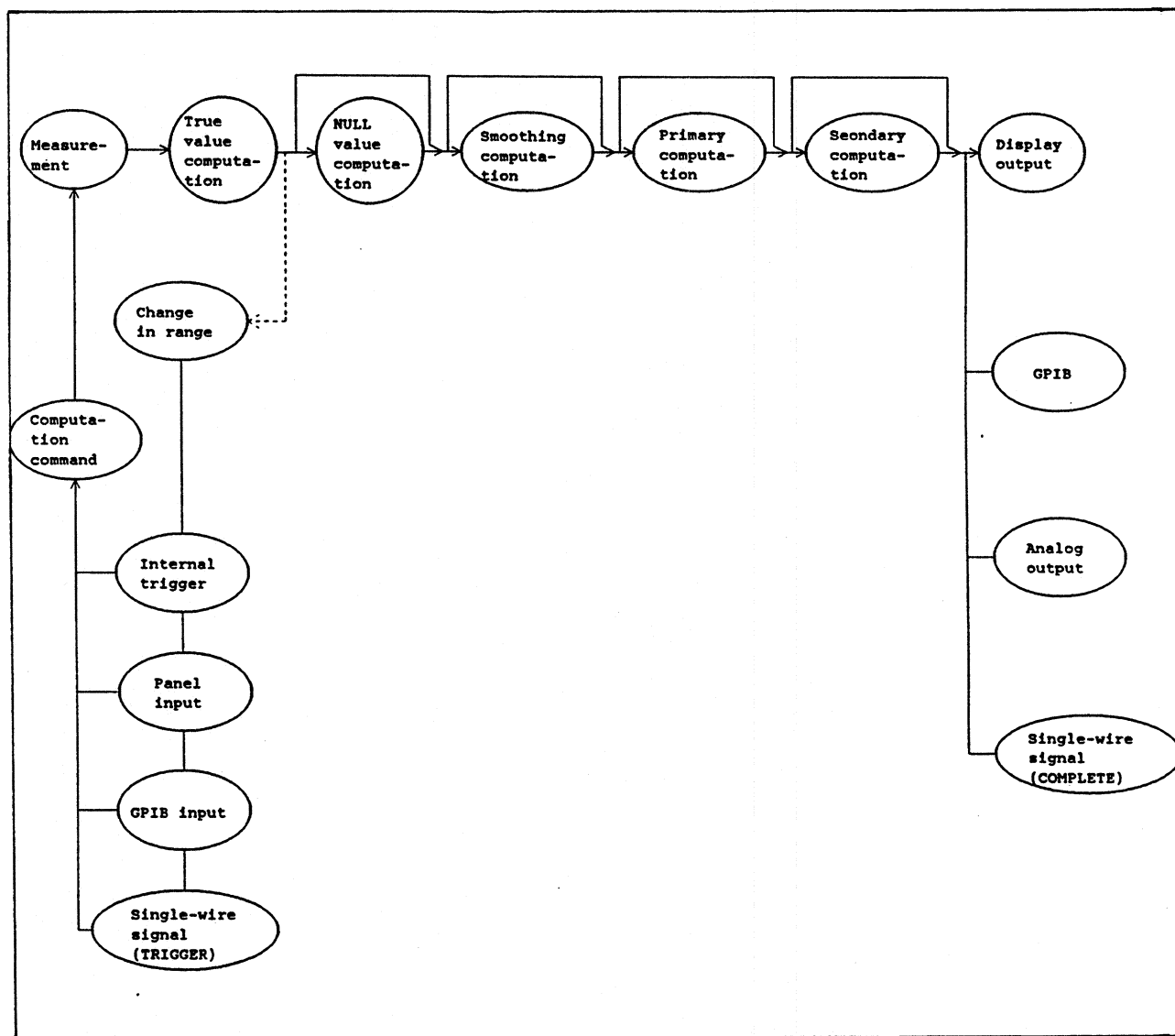

Figure 7 - 1 R6561 Operation Conceptual Diagram

R6561  
DIGITAL MULTIMETER  
OPERATION MANUAL

7.1 Outline

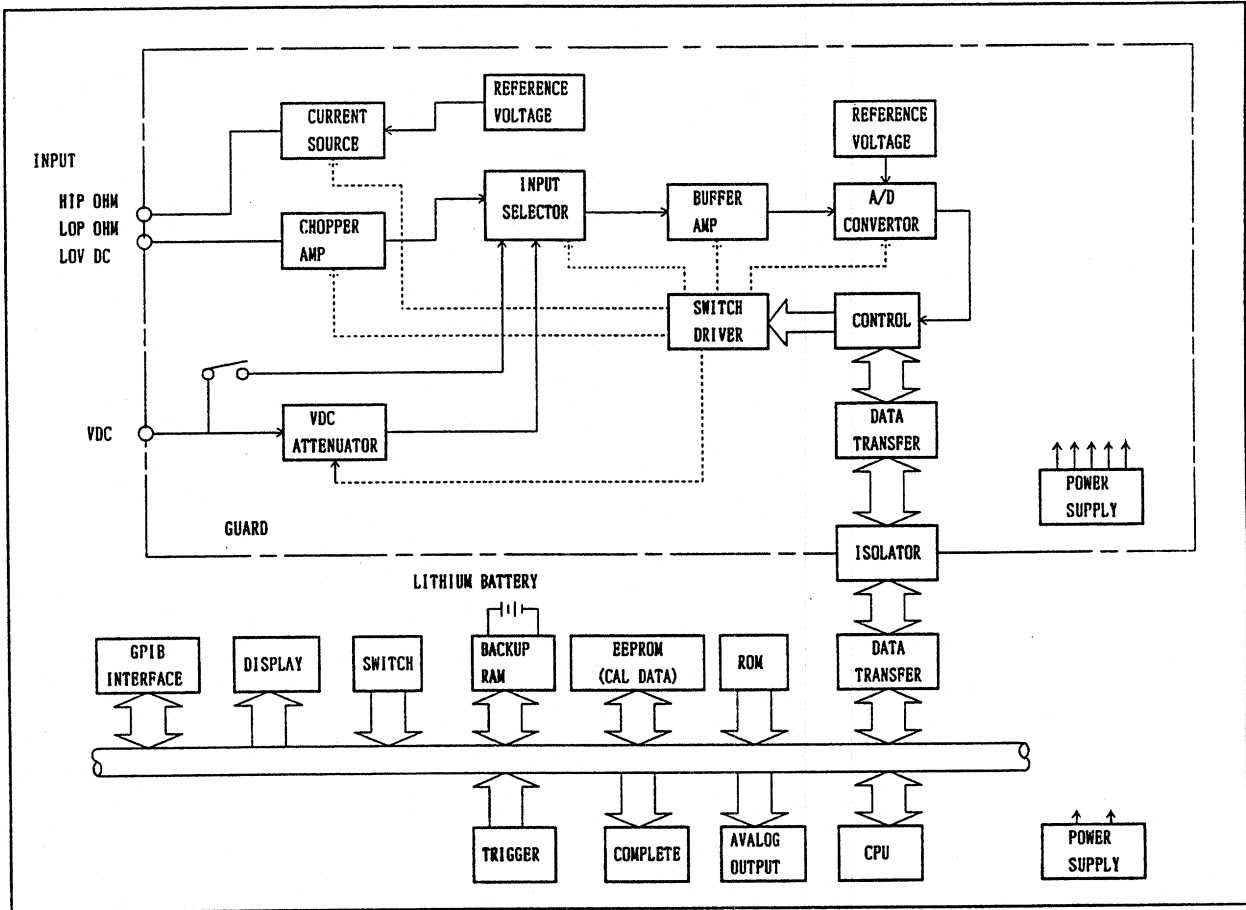

Figure 7 - 2 R6561 Block Diagram

R6561  
DIGITAL MULTIMETER  
OPERATION MANUAL

7.2 Functional Description

---

7.2 Functional Description

See Figure 7-3.

Upon receipt of the measuring command from an internal or external source, the R6561 starts measuring and computes the true values when the measurement ends.

The measurement value of input is decided in this stage. When the AUTO RANGE mode is set (when the AUTO key is set to ON), the R6561 can check if the optimum measuring range is selected to satisfy the input. When it is not set to the optimum range, this equipment changes the measuring range and executes the same operation (input measurement and true value computation) over again.

When a measured value is obtained, the R6561 processes the data according to each function (NULL/smoothing) in the ON/OFF mode.

The primary computation is computed first, followed by the secondary computation.

When the data processing series ends as described above, the R6561 outputs the measurement data to each output system (display, GPIB, and analog output). At the same time, the equipment also outputs the single-wire signal (negative pulse of approx. 130 $\mu$ s from the output terminal COMPLETE).

When the sampling speed is to be increased, it is possible to set each function (NULL, smoothing, and computation) with the ON/OFF function at OFF and the AUTO ZERO at OFF.

When the analog block is calibrated, the AUTO CALIBRATION command is executed for a period set by parameter AUTO CAL with priority over the other measuring commands.

R6561  
DIGITAL MULTIMETER  
OPERATION MANUAL

7.2 Functional Description

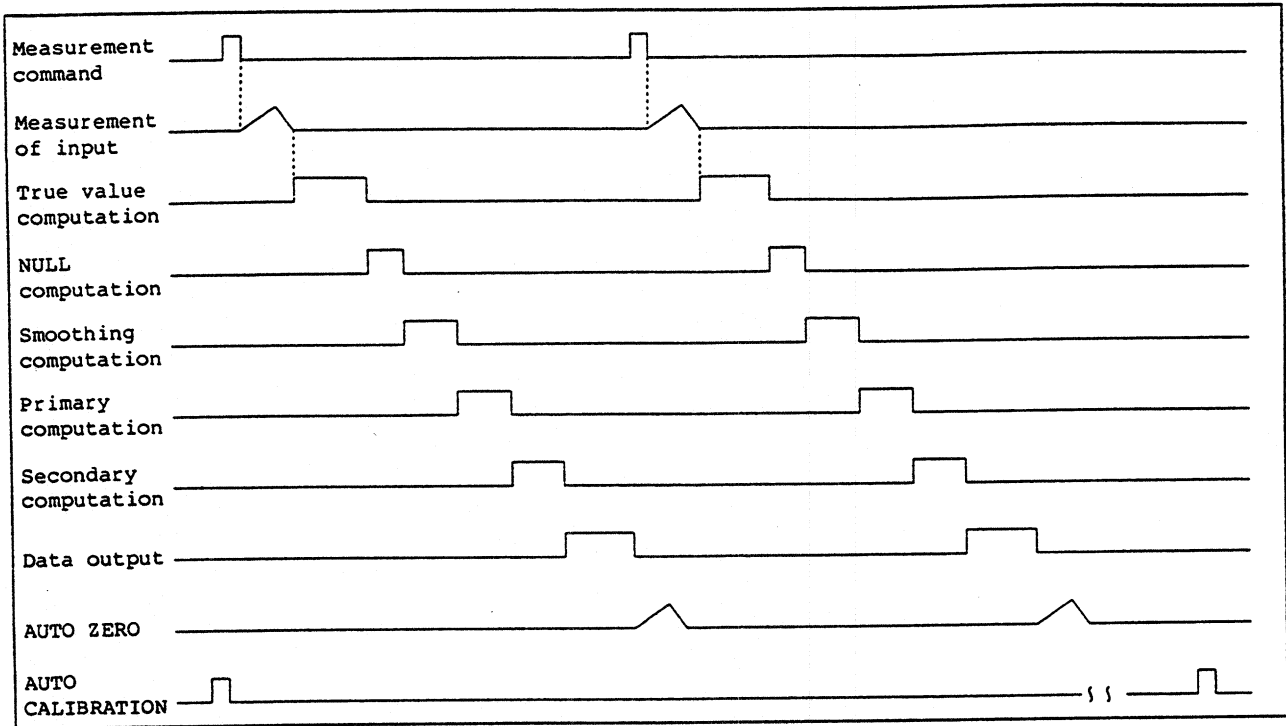

Figure 7 - 3 Data Processing Timing Chart

R6561  
DIGITAL MULTIMETER  
OPERATION MANUAL

A.1 Terminologies

---

APPENDIX

A.1 Terminologies

(1) Sensitivity and Resolution

The resolution of a digital voltmeter is the minimum unit of quantization. For example, the maximum sensitivity range of the R6561 digital multimeter is 1000 $\mu$ V and the resolution is, therefore, 10nV/digit.

This value also represents the sensitivity. The values indicating the sensitivity and resolution of a digital multimeter are vital factors for multimeter selection. They also indicate the limit of multimeter performance.

(2) Measurement Accuracy

The measurement accuracy is defined as follows:

$$\text{Measurement accuracy} = \frac{(\text{Reading value} - \text{True value})}{(\text{Full scale value})} + 1 \text{ digit}$$

The reading value minus true value is called a reading error. The reading error of this multimeter is indicated as  $\pm 0.00XX\%$  of rdg. The full-scale error is indicated as of fs (or digits). The full-scale error and quantization error (explained below) result from different causes. However, the full-scale error may be added the quantization error and displayed for simple calculation of measurement accuracy. The full-scale error is primary caused by zero-point drifting. This drifting is automatically corrected by the automatic zero point correction circuit.

An error within  $\pm 1$  digit is called the quantization error. This may occur during data conversion from analog into digital form.

(3) Input Impedance

A digital voltmeter has its inherent input resistance ( $R_{in}$ ). This is usually called as an input impedance. Voltage  $E_s$  of the power supply (shown in Figure A-1) to be measured is reduced by the output resistance ( $R_s$ ) of the power supply and the input impedance ( $R_{in}$ ), and voltage  $E_s'$  is displayed on the digital multimeter. To reduce the loading error, the input impedance ( $R_{in}$ ) of the digital multimeter must be increased.

R6561  
DIGITAL MULTIMETER  
OPERATION MANUAL

A.1 Terminologies

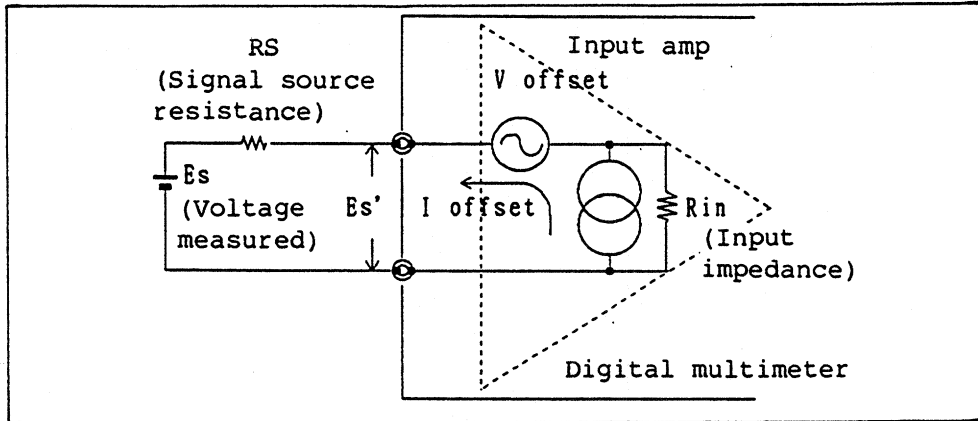

Figure A - 1 Input Equivalent Circuit by Considering Current and Voltage Offsets and Input Impedance

In addition to the error due to the output resistance ( $R_s$ ) of power supply and the input impedance of multimeter, an error due to current offset exists. This current offset occurs inside the multimeter. A voltage offset may also occur, but it can be ignored even when output resistance  $R_s$  increases.

The current offset is caused by elements used in the primary stage of input amplifier. To minimize the offset, field effect transistors (FETs) are used. Therefore, if the power supply to be measured has output resistance  $R_s$ , voltage  $E_s'$  appearing at the input terminal of digital multimeter can be defined in the following equation. Resistance  $R_s$  divided by resistance  $R_{in}$ , are resistance  $R_s$  multiplied by  $I$  offset should be considered.

$$E_s' = \frac{1}{1 + \frac{R_s}{R_{in}}} E_s - R_s \times I \text{ offset}$$

- (4) Normal Mode Noise Voltage Rejection Ratio (NMRR) and Common Mode Noise Voltage Rejection Ratio (CMRR)

A certain level of noise always exist during measurement and this noise causes a measurement error. During low-voltage signal measurement below  $10\mu\text{V}$ , a measurement error is often caused by troubles of grounding or cables, ground current, or induction noise from the power supply. The measurement may fail due to errors. To solve such measurement problems, the R6561 digital multimeter involves the integration measurement and the noise rejectors are included in its power supply.



R6561  
DIGITAL MULTIMETER  
OPERATION MANUAL

A.1 Terminologies

The noise source can be eliminated during measurement by using the measuring circuit shown in Figure A-2. Noise voltage 'en' is called the normal mode noise voltage or series mode noise voltage. The noise voltage is fed in series in the signal line. This noise usually consists of power frequency components and their subharmonics. The affection of these noise components on the measurement or the noise elimination efficiency is called the normal mode noise voltage rejection ratio (NMRR). The NMRR can be determined by the following equation:

$$\text{NMRR} = 20 \log \frac{e_n}{\Delta e_n}$$

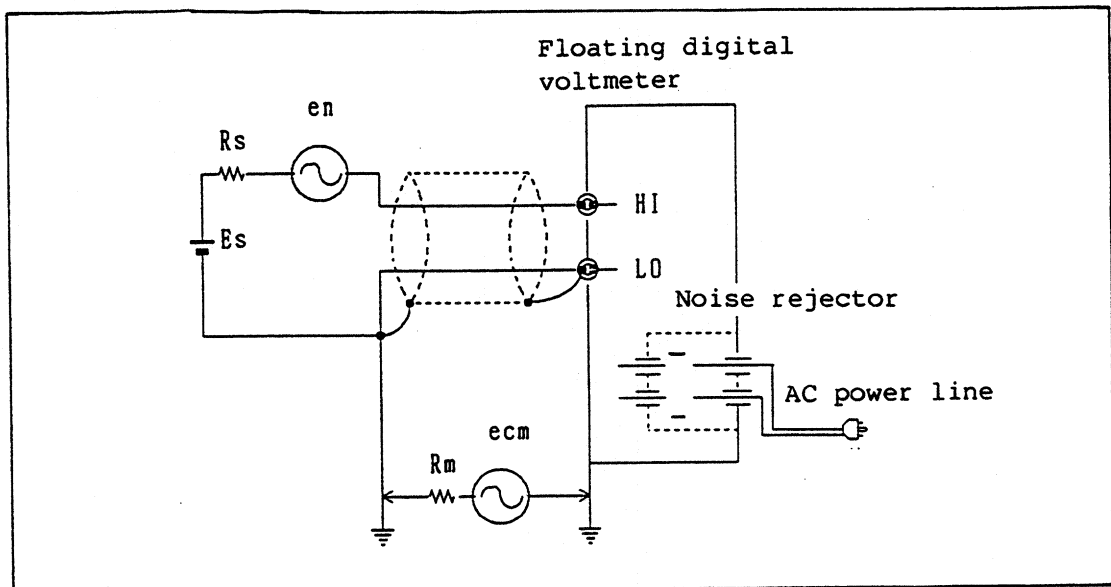

Figure A - 2 Measuring Circuit Featuring Effective Noise Elimination

' $\Delta e_n$ ' is the measurement error caused by 'en'. 'ecm' is a noise, called the common mode noise voltage, and occurs between the signal line and the ground of multimeter. The noise level increase if the distance between them increases.

The affection of the noise components on the measurement, or its noise elimination efficiency is called the common mode noise voltage rejection ratio (CMRR). The CMRR can be defined by the following equation:

$$\text{CMRR} = 20 \log \frac{e_{cm}}{\Delta e_{cm}}$$

R6561  
DIGITAL MULTIMETER  
OPERATION MANUAL

A.1 Terminologies

---

' $\Delta_{ecm}$ ' is the voltage that appears at the input terminal of the multimeter. The combination efficiency of the above two noise voltage rejection ratios is indicated as the effective CMR. The R6561 multimeter using the integration calculation can provide the higher NMR.

The CMR greatly varies depending on the frequency of noise voltage, signal source circuit, shielding, input cable type, and input connection. If the CMR of 120dB is shown on the multimeter document and if the errors are ignored in the 'ecm' voltage exceeding  $1/10^6$ , the measured data is unreliable. A shielded cable should be connected to the multimeter to eliminate any induction, and the ground lead of the power cable should be connected directly to the ground. The multimeter digital display (calculation) section is electrically disconnected from the A/D converter section. Dual shielding of the measuring circuits from the ground allows the highest common mode noise voltage rejection ratio.

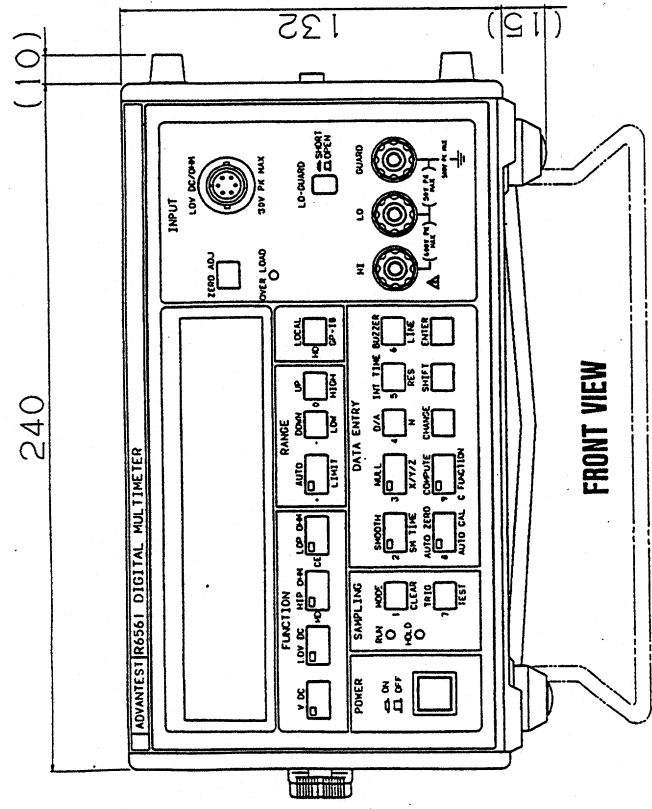

FRONT VIEW

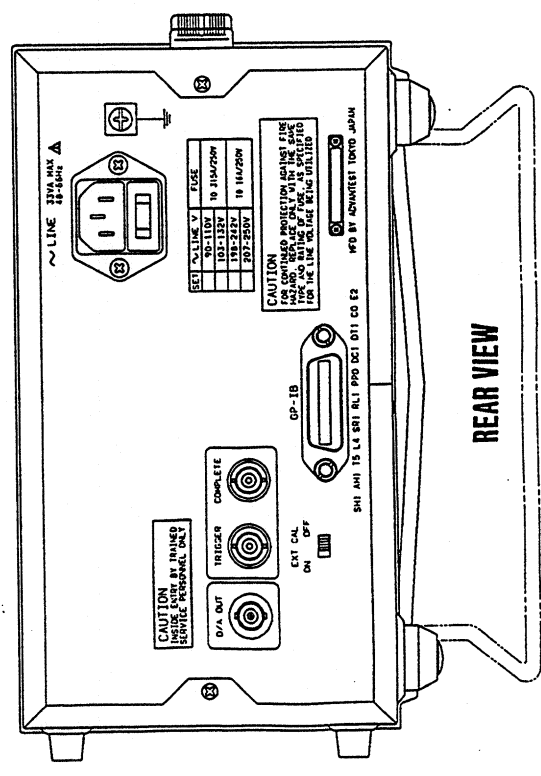
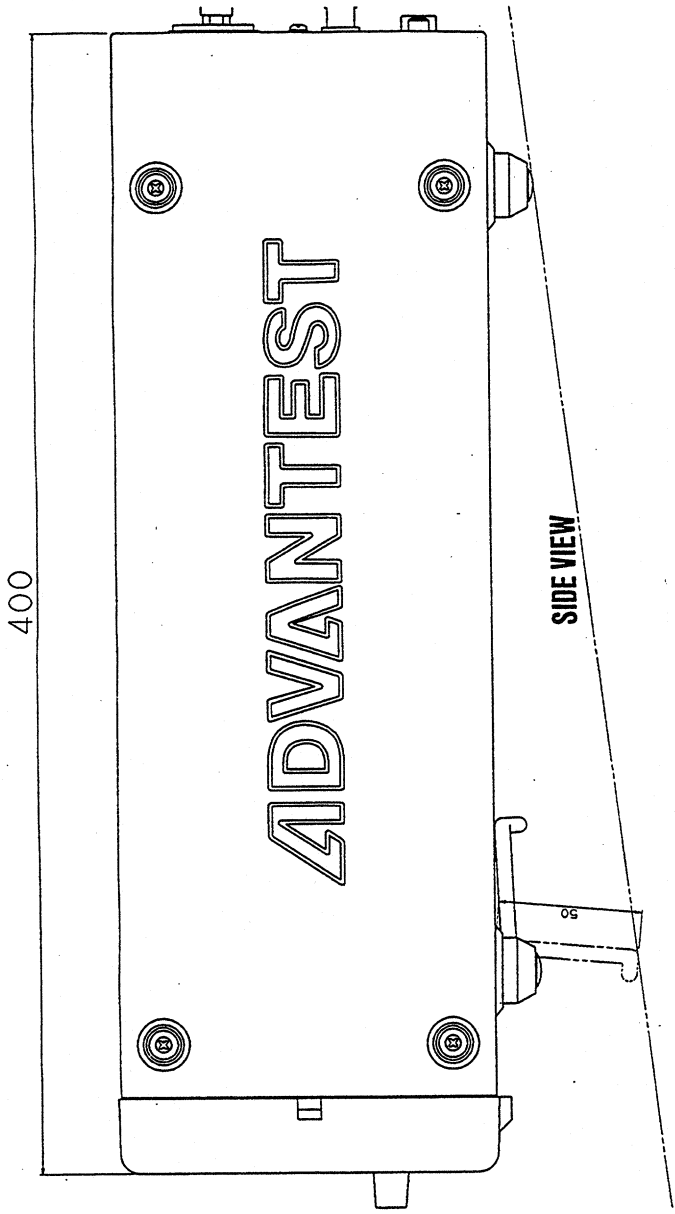

REAR VIEW

Unit : mm

R6561

EXTERNAL VIEW



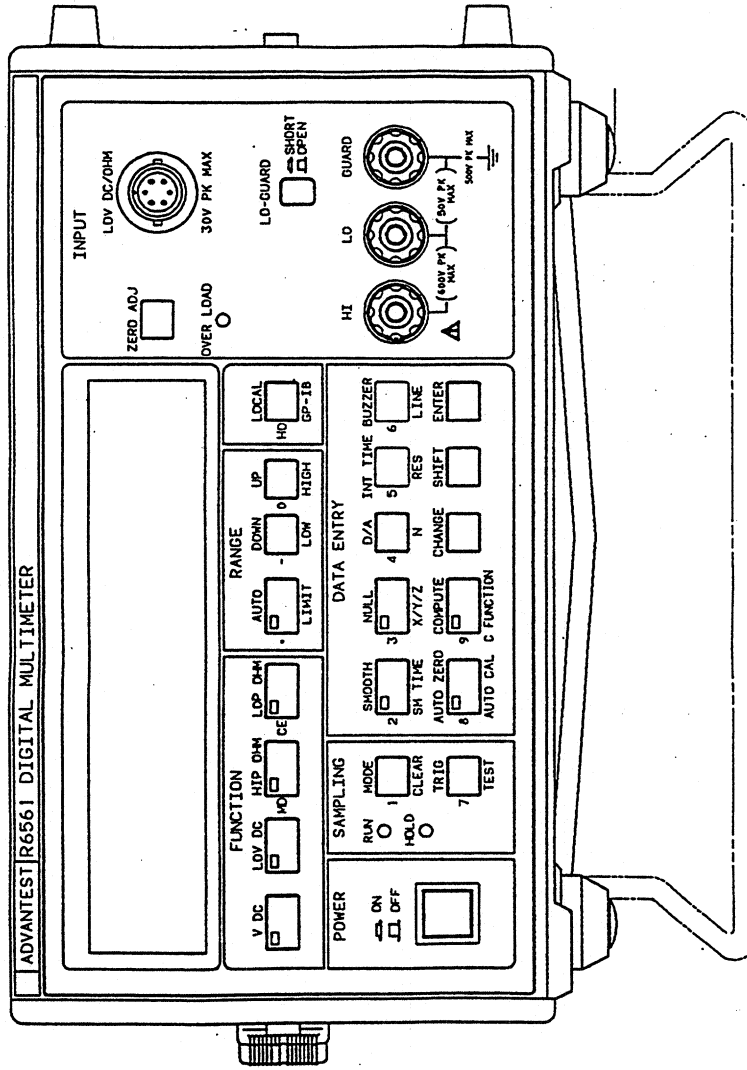

ADVANTEST R6561 DIGITAL MULTIMETER

R6561  
FRONT VIEW

R6561EXT2-809-A



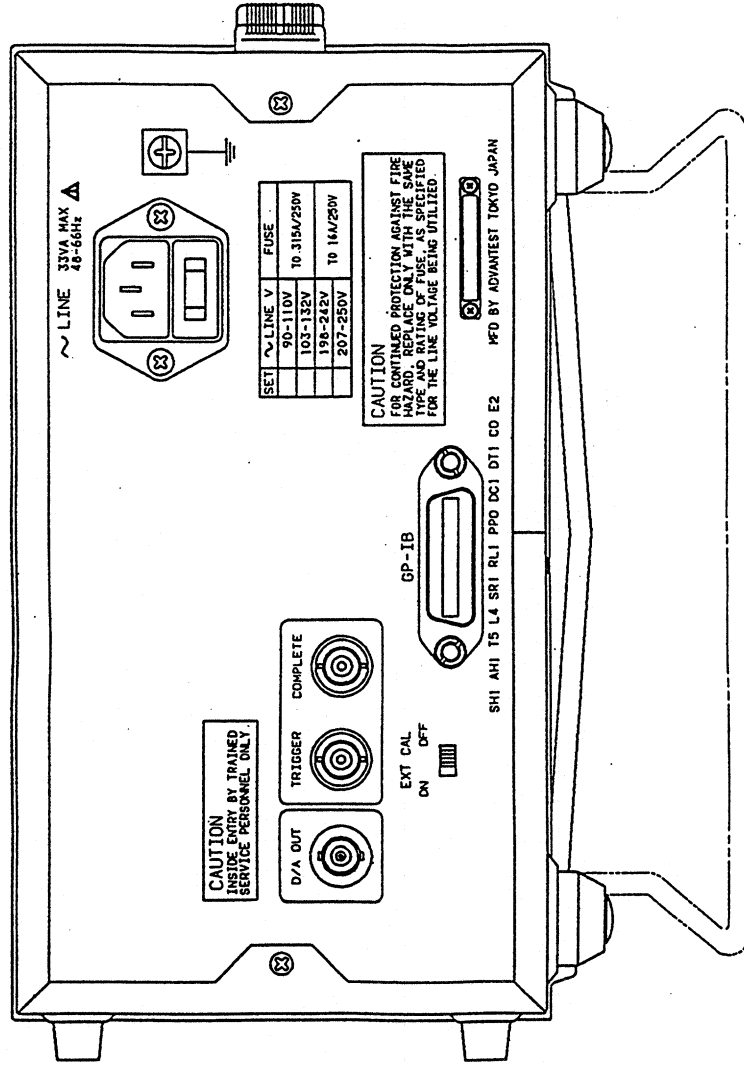

R6561

REAR VIEW

R6561TEXT3-809-A





R6561  
DIGITAL MULTIMETER  
OPERATION MANUAL

List of Figures

LIST OF FIGURES

No.	Title	Page
1 - 1	Composition of this Manual .....	1 - 1
1 - 2	Plug and Adapter for Power Cable .....	1 - 5
1 - 3	Fuse Holder .....	1 - 6
2 - 1	Relationship between Raw Measured Value and Measured Value After Smoothing .....	2 - 63
2 - 2	DC Voltage Measuring Input Cable Connection Diagram .....	2 - 71
2 - 3	Low Voltage DC Measuring Input Cable Connection Diagram .....	2 - 73
2 - 4	Resistance Measurement Input Cables Connection Diagram .....	2 - 76
3 - 1	Scaling for Direct Reading of 4 to 20mV Sensor/Transmitter .....	3 - 4
3 - 2	Example of Application to the Computation of % Deviation (Measurement of Deviation in Resistance Value when $X = 150\Omega$ ) .....	3 - 6
3 - 3	Application Example of DELTA .....	3 - 8
4 - 1	Outline of GPIB .....	4 - 3
4 - 2	Signal Line Termination .....	4 - 4
4 - 3	GPIB Connector Pin Assignment Diagram .....	4 - 5
4 - 4	Relationship between Operation Status and each Bit at the Service Request .....	4 - 29
4 - 5	Flowchart of GPIB Operation .....	4 - 32
4 - 6	Operation Timing when a Service Request Occurs (1 of 2) .....	4 - 34
4 - 6	Operation Timing when a Service Request Occurs (2 of 2) .....	4 - 35
5 - 1	Calibration of DC Voltage Measurement .....	5 - 9
5 - 2	Calibration of Low Voltage DC Measurement (1000 $\mu$ V/10mV range) .....	5 - 17
5 - 3	Calibration of Low Voltage DC Measurement (100mV to 10V range) .....	5 - 17
5 - 4	Calibration of Resistance Measurement .....	5 - 24
7 - 1	R6561 Operation Conceptual Diagram .....	7 - 1
7 - 2	R6561 Block Diagram .....	7 - 2
7 - 3	Data Processing Timing Chart .....	7 - 4
A - 1	Input Equivalent Circuit by Considering Current and Voltage Offsets and Input Impedance .....	A - 2
A - 2	Measuring Circuit Featuring Effective Noise Elimination .....	A - 3



R6561  
DIGITAL MULTIMETER  
OPERATION MANUAL

List of Tables

LIST OF TABLES

No.	Title	Page
1 - 1	Standard Accessories of R6561 .....	1 - 4
1 - 2	Fuse Standards .....	1 - 6
2 - 1	R6561 Measuring Range Configuration .....	2 - 14
2 - 2	Auto Range Level .....	2 - 15
2 - 3	Computing Function .....	2 - 34
2 - 4	Relationship between Measuring Functions and the Number of Display Digits .....	2 - 39
4 - 1	Interface Function .....	4 - 6
4 - 2	Standard Bus Cables (to be purchased at cost) .....	4 - 7
4 - 3	ASCII Code Coordination Address Codes Table .....	4 - 9
4 - 4	Status Change by Command .....	4 - 11
4 - 5	Summary of General Format .....	4 - 13
4 - 6	General Format Header .....	4 - 14
4 - 7	Mantissa and Exponent Under Various Measuring Conditions .....	4 - 16
4 - 8	Program Code (1 of 7) .....	4 - 19
4 - 8	Program Code (2 of 7) .....	4 - 20
4 - 8	Program Code (3 of 7) .....	4 - 21
4 - 8	Program Code (4 of 7) .....	4 - 22
4 - 8	Program Code (5 of 7) .....	4 - 23
4 - 8	Program Code (6 of 7) .....	4 - 24
4 - 8	Program Code (7 of 7) .....	4 - 25
4 - 9	Measuring Range Code of R6561 .....	4 - 25
5 - 1	Devices Required for Calibration .....	5 - 6
5 - 2	Tolerance Range of each Item of Data in the Execution of EXT CAL (1 of 2) .....	5 - 7
5 - 2	Tolerance Range of each Item of Data in the Execution of EXT CAL (2 of 2) .....	5 - 8



## **IMPORTANT INFORMATION FOR ADVANTEST SOFTWARE**

PLEASE READ CAREFULLY: This is an important notice for the software defined herein. Computer programs including any additions, modifications and updates thereof, operation manuals, and related materials provided by Advantest (hereafter referred to as "SOFTWARE"), included in or used with hardware produced by Advantest (hereafter referred to as "PRODUCTS").

### **SOFTWARE License**

All rights in and to the SOFTWARE (including, but not limited to, copyright) shall be and remain vested in Advantest. Advantest hereby grants you a license to use the SOFTWARE only on or with Advantest PRODUCTS.

### **Restrictions**

- (1) You may not use the SOFTWARE for any purpose other than for the use of the PRODUCTS.
- (2) You may not copy, modify, or change, all or any part of, the SOFTWARE without permission from Advantest.
- (3) You may not reverse engineer, de-compile, or disassemble, all or any part of, the SOFTWARE.

### **Liability**

Advantest shall have no liability (1) for any PRODUCT failures, which may arise out of any misuse (misuse is deemed to be use of the SOFTWARE for purposes other than its intended use) of the SOFTWARE. (2) For any dispute between you and any third party for any reason whatsoever including, but not limited to, infringement of intellectual property rights.

## LIMITED WARRANTY

1. Unless otherwise specifically agreed by Seller and Purchaser in writing, Advantest will warrant to the Purchaser that during the Warranty Period this Product (other than consumables included in the Product) will be free from defects in material and workmanship and shall conform to the specifications set forth in this Operation Manual.
2. The warranty period for the Product (the "Warranty Period") will be a period of one year commencing on the delivery date of the Product.
3. If the Product is found to be defective during the Warranty Period, Advantest will, at its option and in its sole and absolute discretion, either (a) repair the defective Product or part or component thereof or (b) replace the defective Product or part or component thereof, in either case at Advantest's sole cost and expense.
4. This limited warranty will not apply to defects or damage to the Product or any part or component thereof resulting from any of the following:
  - (a) any modifications, maintenance or repairs other than modifications, maintenance or repairs (i) performed by Advantest or (ii) specifically recommended or authorized by Advantest and performed in accordance with Advantest's instructions;
  - (b) any improper or inadequate handling, carriage or storage of the Product by the Purchaser or any third party (other than Advantest or its agents);
  - (c) use of the Product under operating conditions or environments different than those specified in the Operation Manual or recommended by Advantest, including, without limitation, (i) instances where the Product has been subjected to physical stress or electrical voltage exceeding the permissible range and (ii) instances where the corrosion of electrical circuits or other deterioration was accelerated by exposure to corrosive gases or dusty environments;
  - (d) use of the Product in connection with software, interfaces, products or parts other than software, interfaces, products or parts supplied or recommended by Advantest;
  - (e) incorporation in the Product of any parts or components (i) provided by Purchaser or (ii) provided by a third party at the request or direction of Purchaser or due to specifications or designs supplied by Purchaser (including, without limitation, any degradation in performance of such parts or components);
  - (f) Advantest's incorporation or use of any specifications or designs supplied by Purchaser;
  - (g) the occurrence of an event of force majeure, including, without limitation, fire, explosion, geological change, storm, flood, earthquake, tidal wave, lightning or act of war; or
  - (h) any negligent act or omission of the Purchaser or any third party other than Advantest.
5. **EXCEPT TO THE EXTENT EXPRESSLY PROVIDED HEREIN, ADVANTEST HEREBY EXPRESSLY DISCLAIMS, AND THE PURCHASER HEREBY WAIVES, ALL WARRANTIES, WHETHER EXPRESS OR IMPLIED, STATUTORY OR OTHERWISE, INCLUDING, WITHOUT LIMITATION, (A) ANY WARRANTY OF MERCHANTABILITY OR FITNESS FOR A PARTICULAR PURPOSE AND (B) ANY WARRANTY OR REPRESENTATION AS TO THE VALIDITY, SCOPE, EFFECTIVENESS OR USEFULNESS OF ANY TECHNOLOGY OR ANY INVENTION.**
6. **THE REMEDY SET FORTH HEREIN SHALL BE THE SOLE AND EXCLUSIVE REMEDY OF THE PURCHASER FOR BREACH OF WARRANTY WITH RESPECT TO THE PRODUCT.**
7. **ADVANTEST WILL NOT HAVE ANY LIABILITY TO THE PURCHASER FOR ANY INDIRECT, INCIDENTAL, SPECIAL, CONSEQUENTIAL OR PUNITIVE DAMAGES, INCLUDING, WITHOUT LIMITATION, LOSS OF ANTICIPATED PROFITS OR REVENUES, IN ANY AND ALL CIRCUMSTANCES, EVEN IF ADVANTEST HAS BEEN ADVISED OF THE POSSIBILITY OF SUCH DAMAGES AND WHETHER ARISING OUT OF BREACH OF CONTRACT, WARRANTY, TORT (INCLUDING, WITHOUT LIMITATION, NEGLIGENCE), STRICT LIABILITY, INDEMNITY, CONTRIBUTION OR OTHERWISE. TORT (INCLUDING, WITHOUT LIMITATION, NEGLIGENCE), STRICT LIABILITY, INDEMNITY, CONTRIBUTION OR OTHERWISE.**
8. **OTHER THAN THE REMEDY FOR THE BREACH OF WARRANTY SET FORTH HEREIN, ADVANTEST SHALL NOT BE LIABLE FOR, AND HEREBY DISCLAIMS TO THE FULLEST EXTENT PERMITTED BY LAW ANY LIABILITY FOR, DAMAGES FOR PRODUCT FAILURE OR DEFECT, WHETHER ARISING OUT OF BREACH OF CONTRACT, TORT (INCLUDING, WITHOUT LIMITATION, NEGLIGENCE), STRICT LIABILITY, INDEMNITY, CONTRIBUTION OR OTHERWISE.**

## CUSTOMER SERVICE DESCRIPTION

In order to maintain safe and trouble-free operation of the Product and to prevent the incurrence of unnecessary costs and expenses, Advantest recommends a regular preventive maintenance program under its maintenance agreement.

Advantest's maintenance agreement provides the Purchaser on-site and off-site maintenance, parts, maintenance machinery, regular inspections, and telephone support and will last a maximum of ten years from the date the delivery of the Product. For specific details of the services provided under the maintenance agreement, please contact the nearest Advantest office listed at the end of this Operation Manual or Advantest's sales representatives.

Some of the components and parts of this Product have a limited operating life (such as, electrical and mechanical parts, fan motors, unit power supply, etc.). Accordingly, these components and parts will have to be replaced on a periodic basis. If the operating life of a component or part has expired and such component or part has not been replaced, there is a possibility that the Product will not perform properly. Additionally, if the operating life of a component or part has expired and continued use of such component or part damages the Product, the Product may not be repairable. Please contact the nearest Advantest office listed at the end of this Operation Manual or Advantest's sales representatives to determine the operating life of a specific component or part, as the operating life may vary depending on various factors such as operating condition and usage environment.

## SALES & SUPPORT OFFICES

Advantest (Singapore) Pte. Ltd.

6 Serangoon North Avenue 5, #06-03 Singapore 554910

Phone: +65-6752-5990

Fax: +65-6752-3910

**ADVANTEST**<sup>®</sup>

<http://www.advantest.co.jp>

