

# A portable 10 MHz Rubidium Frequency Reference using the FE-5680A

## *A warning if you plan to use the FE-5680A as a 10 MHz reference for microwave transverters:*

As a 10 MHz reference for microwave transverters, I've found the "barefoot" FE-5680A to be unsuitable for microwave transverters due to low-level audio-frequency phase modulation on the output.

*To use the FE-5680A with a microwave transverter it is necessary to "clean up" its output by locking another crystal oscillator to it [as described below](#).*

## *Completely different FE-5680A's in seemingly identical packages:*

There are a number of versions of the FE-5680A on the surplus market - some of which are *very* different from each other but unfortunately, the outsides of these units appear nearly identical with no obvious means of telling which version is which. At the time of the original writing of this page (December 2011) there were two types of FE-5680A available and which version one got depended partly on luck and also on how informed the seller of the device is on which type is being offered.

### **The most common types of FE-5680A seem to be:**

- Frequency Programmable.** This version uses DDS techniques to produce an output frequency that is programmable in sub-hertz steps from around 20 MHz down to audio frequencies (after modification) and these units have been used by hobbyists as signal generators and as exciters for LF/MF/HF beacon transmitters. These units are *not* generally suitable as references for microwave transverters or as ultra-precise arbitrary frequency generators due to the fact that the DDS techniques used tend to generate low-level spurious signals and that the *exact* frequency being synthesized is limited to small - but discrete - steps dictated by the finite resolution of the DDS chip itself. These units can be programmed via the serial interface in a human-readable manner using a "dumb" terminal program and other programs to set frequencies more conveniently (e.g. without a calculator!) are readily available. [This "programmable" variety is the version described on the the ZL1BPU Rubidium page.](#) As of late 2011/early 2012, this type is the more expensive of the two and less common, often selling in the \$60-\$90 area. *These units are definitely not suitable for use as a frequency reference for a microwave transverter without a "clean-up" oscillator such as the one described below and their finite tuning resolution may produce slightly "off-frequency" results when multiplied to microwave frequencies.*
- "Non-Programmable".** This version does *not* have a synthesizer that can be steered over a wide range, but rather separate 10 MHz and 1 pps (pulse-per-second) outputs found on the 9-pin D connector. These units typically require an external 5 volt source to operate some of the internal logic and programming via the serial interface requires that raw bytes be sent to "tweak" (by only a tiny fraction of a Hertz!) the 10 MHz *precisely* to frequency. Internally, all components are installed on ONE circuit board. [This "Non-Programmable" unit is the version described on the VK3UM Rubidium page.](#) As of late 2011/early 2012, this type appears to be the less expensive (\$30-\$45 typically) and more common variety. Even though these units appear to have "cleaner" RF outputs than the "programmable" versions, they are *not* directly suitable for use as a 10



**Figure 1:**

*The complete FE-5680A-based 10 MHz reference.  
Click on the image for a larger version.*

MHz frequency reference for microwave transverters and require a "clean-up" oscillator as noted above.

- **The "8.3886 MHz" version.** There seems to be a version that outputs 1PPS and 8.3866something MHz from a tiny RF connector on an internal board. *I don't have one of these units, nor do I have any information as to whether or not these can be made into a useful frequency reference.*

*It is the 2<sup>nd</sup> of these, the "Non-Programmable" version, that is described as being used on this page!*

## Why a frequency reference?

When operating on the microwave amateur radio bands, narrowband modes (such as SSB or CW) are often used to maximize the link margin - that is, being able to talk when signals are weak as the SSB or CW modes can offer 10's of dB improvement over the wideband FM modes used with Gunn transceivers.

There is a catch, however: The use of microwave frequencies *and* narrowband modes such as SSB or CW means that the one must maintain pretty good frequency stability *and* accuracy:

- **Stability is important!** A drift of even a few hundred Hz at the operating frequency (in the GHz range!) can affect intelligibility of voice - or, if CW is being used for weak-signal work, such drifting can move the received signal outside the receiver's passband filter. Having to "chase" the frequency around is not only distracting, but it complicates being able to communicate in the first place.
- **Accuracy is critical!** Because it is important that both parties be confident that their stated operating frequencies are reasonably close to where they think they are, frequency-wise, it's important that the frequency be precisely known. If a contact is arranged beforehand it is vital that both parties be able to find each other simply by knowing the intended frequency of communication and as long as the two parties are within several hundred Hz of each other, it is more likely that they will be able to complete the contact. If the error was on the order of several kHz or 10's of kHz, "hunting" would be required to find the signal and if those signals are weak, they might be missed entirely - particularly if, in addition to tuning around, it was necessary to move the antennas about as well.

Because achieving such stability and accuracy requires some effort, it is more convenient if microwave gear is constructed such that it can use a common, external frequency reference and lock to it, and this is true for several reasons:

- **Only one reference is required.** It's better to expend the effort in putting together just one "master", stable reference rather than each piece of gear having its own reference. In this way, the extra money, time and effort saved can be put toward having this one reference be as good as you can make it.
- **Power savings.** Having a common reference can also be convenient if

### *"I can't see the 1pps output!"*

One comment frequently seen by those who are evaluating the FE-5680A is that they are unable to see the 1PPS output.

If you are using an old, analog type scope, it is *very difficult* to see this pulse since it is only a *microsecond* or so wide. Since it occurs only once every second - and because it is so brief - it is slightly tricky to get even a good-quality 'scope to trigger on it.

To do this, one must *very carefully* adjust the triggering threshold and configure the 'scope so that it sweeps *only* when triggered rather than repeatedly. Even with a good, bright tube in the scope, it often requires that the intensity be turned way up and the room darkened to see the "occasional", narrow pulse as it gets painted on the quickly-fading phosphor!

It's often a bit easier to get a DSO (Digital Storage Oscilloscope) to display this pulse since, unlike an old analog scope one can simply set the sweep to show about a microsecond per division and easily see the pulse once the 'scope is properly triggered.

Perhaps the *easiest* way to detect the 1PPS pulse is to connect a small audio amplifier to the output and turn up the volume. For this I used

one is operating portable using battery power. Using an external reference means that one doesn't need to keep all of those individual pieces of gear "warmed up" all of the time to maintain stability, turning it on (and draining battery power) only when it is needed. For this reason, many amateur radio operators (and commercial equipment manufacturers, for that matter) design their gear to accept a 10 MHz input from a known-accurate and stable source.

a cheap, Radio Shack amplified speaker and was readily able to hear the once-per-second "tick" of the output once the unit warmed up!

In addition to rubidium references I also have a [10 MHz "ovenized" crystal oscillator](#) that I generally use instead of a "ruby." While not as accurate, the crystal oscillator's stability and accuracy is more than adequate for operation at least through 24 GHz (*it is within a few hundred Hz at that frequency*) and consuming significantly less power to operate than the Rubidium reference - an important consideration when operating from battery power. Nevertheless, it's nice to have something that is portable and "dead on" frequency in less than 5 minutes after cold startup and can also be used as a backup if necessary.

### ***About this frequency reference:***

The FE-5680A was originally used in mobile/cellular telephone sites to provide an accurate frequency and/or timing reference for network synchronization, etc. and as such, it has very good intrinsic accuracy as compared to conventional quartz oscillators. After their end-of-life, the equipment was sent overseas to be "recycled" and in the process, these units have appeared on EvilBay with many being shipped back, into the hands of experimenters.

A rubidium reference - unlike a quartz crystal oscillator which has no clearly-defined "wear out" period and, if well-designed, can actually *improve* as time goes on - has a definite lifetime associated with its lamp: As the unit operates, the Rubidium within the lamp is less-available to be vaporized and eventually, too little is available for the atomic resonance to be detected and the unit fails to achieve lock and it is for this reason that many amateurs who have Rubidium references choose *not* to leave them on all of the time. For "base station" use a GPS-based disciplined quartz oscillator is often used as the "primary" reference against which the Rubidium unit is compared, but since a GPS-based disciplined reference is, by its nature, not "portable" - that is, you can't just move it around unless you stay in one location for many hours, giving it time to re-lock and the disciplined oscillator to achieve reasonable accuracy - a Rubidium reference fills the niche, providing very high accuracy and stability in a portable package..

At "room temperature" (approx. 68F or 20C) the FE-5680A takes about 3 minutes to warm up and "lock" (much faster than a crystal-oven reference!) almost immediately providing accuracy equal to or better than a good-quality "ovenized" quartz oscillator. The version of the The FE-5680A described here has available - via its serial port - a means to make fine adjustments to the output frequency, allowing "tweaking" of the 10 MHz output frequency to within a few parts of 10E11 under stable "bench-top" conditions. (*The actual adjustment steps are much finer than that, but the degree of stability noted is more realistic.*)

The FE-5680A has an output that goes from high (4.5-5 volts) to low (0-0.5 volts) when the "physics lock" has been detected. It should be noted that until this indication is made the 10 MHz output will be sweeping a few 10's or hundreds of Hz and it ***should not be trusted*** to provide any sort of accurate frequency reference, but at the ***instant*** it goes low it will likely be within about 10E-7, gradually achieving something that's closer to its ultimate accuracy over the next 5-10 minutes.

This unit also has a 1pps output (*present ***only*** if a "physics lock" has been achieved*) that provides a positive-going pulse that is about 1 microsecond wide: Unless you are pretty good at tweaking, you may have a bit of trouble seeing it on an analog oscilloscope other than by observing that the "trigger" light would flash every second, so the ***easiest*** way to detect it is by "listening" to it with an audio amplifier.

### **Pinout of the FE-5680A:**

***This version*** of the FE-5680A interfaces via a DE-9 connector - its *only* external connector - through which power is applied and signals (including the 10 MHz) emerge. These pins are used as follows:

1. V+ input (15-18 volts, typical.) The current is more or less constant across this voltage range with 15 volts producing less heat and consuming less power.
2. Ground - *the same as pin 5.*
3. Lock indication: High (>4 volts) = Error and/or unlocked; Low (<0.5 volts) = Physics lock (e.g. on-frequency)
4. +5 Volts. Most units lack an internal 5 volt supply and require this voltage to operate. The current consumption is only a few hundred milliamps, easily supplied by an external 7805 regulator.
5. Ground - *the same as pin 2.*
6. 1 PPS (Pulse Per Second) output. A 1 microsecond-wide pulse appears on this pin once the unit has achieved lock and the lock indication pin goes low. This pulse can be difficult to see on some oscilloscopes, but can be easily "heard" with an audio amplifier. ***There will be no output until pin 3 goes low, indicating that a lock has occurred.***
7. 10 MHz output. The accuracy of this output should ***not*** be trusted unless there is a lock indication (e.g. pin 3 is low.)
8. Serial data RX, RS-232 levels. Binary commands are used to adjust the unit's frequency to precisely net it to frequency using a program such as the one linked on VK3UM's page (*see above.*)
9. Serial data TX, RS-232 levels. Used in conjunction with pin 8.

Again, before applying power you ***must*** verify that this unit is of the proper type! Remember: Although the different units are labeled as being an "FE-5680A", there are a number of variants and it may be possible to cause damage if one applies power to a unit with a different pinout or input requirements. To determine the version that you have, refer to the links at the top of the page as well as the pictures in Figure 3, below.

Most of the units available at the time of the original writing of this page (early 2012) are of the "non programmable" variety - that is, they output ***only*** 10 MHz - which are the type described on this page. Over time, it appears that other, similar-looking units appear that may or may not be suitable: One must at least partially rely on the knowledge and integrity of the seller to be sure that you are getting the proper unit.

## Putting it in a box:

I happen to have a large number of "pre-owned" Hammond 1590D die-cast aluminum boxes kicking around (*they had previously housed Glencom VC-510 units*) so it was a "natural" to cram the FE-5680A and its associated support circuitry into it. Experience with the [Efratom LPRO-101](#) has shown that this box capable of adequately dissipating the heat generated and since the overall power requirements of the '5680A are similar, I figured that the box would do fine for it as well.

Before mounting it on the lid I used a rotary tool to remove a few protruding mold marks on the inside that would have prevented the unit from mounting flat against its surface. Because of the large area, I didn't really bother with cleaning off much paint - nor did I smear it with heat sink compound and have noted that the unit's cover temperature and the top (outside) of the lid are at about the same temperature when operating. At room temperature I see a 25-30 degree F (11-16C) rise which indicates a "lid" temperature that is around 105F (around 40C), well with in "safe" operating conditions in all but high ambient temperatures.

This "used" Hammond box already had several holes in it: The one on the rear was covered with a piece of tape on the outside and then filled from the inside with 2-part epoxy (after removing paint from the inside area around the hole) to seal it up to keep bugs and dirt out. Other holes on the opposite end of the box happened to be in convenient locations already and a few more were drilled to accommodate the three BNC connectors for the 10 MHz outputs and the status indicator LED. I cut a small piece of glass-epoxy copper clad board, secured it with two 4-40 screws and covered a hole on the opposite end and mounted in it a solder-in feedthrough capacitor using one of the screws to hold a strain relief clip for the power connection wire.

---

## Power supply and status indicator:

## Comment:

- The information in [my write-up about using the Efratom LPRO-101](#) could also be used with the FE-5680A and vice-versa, the only important difference being that the FE-5680A will run happily on 15 volt whereas the LPRO-101 needs a minimum of 19 volts. It is worth mentioning that the LPRO-101 has an output that is sufficiently clean as to **NOT** require a clean-up oscillator to be used as a reference for microwave transverters.

## Voltage up-converter:

When I packaged my [LPRO-101](#) I "rolled my own" switching converter using the LM2577 chip. It was easy enough to do, but I decided to look around for some pre-built modules and found on EvilBay some cheap switching up converter that appeared to have the necessary capabilities to provide an up-converted voltage for the FE-5680A - all for \$2.99 plus shipping: This was than *less* the low quantity cost of *just* the LM2577 I'd used with my LPRO-101! If I'd wanted to do so, I could have simply replicated the same voltage converter that I'd built for the LPRO-101 and adjusted its output voltage for 15 volts.

When I received the voltage converter units I noted that the build quality was "ok", but not great (what do you expect for \$2.99?) and when tested to see how well it powered the FE-5680A I found that it went into current limiting when the '5680A was cold, lengthening the warm-up time of the unit. The modification to ameliorate this was simple: Increase the current capability slightly by soldering a resistor across R1/R2. In this case I used a pair of paralleled 1 ohm, 1/4 watt units (because I couldn't find a 0.33 or 0.47 ohm watt resistor in my resistor collection at the time) to boost the current capability.

Now, the unit still goes into current limiting when cold, but even at the lower voltage (which is, at worst case, a diode drop below the supply voltage) the internal heaters quickly warm and in a few 10's of seconds, current consumption drops and the voltage rises to the required 15 volts to properly run the '5680A. As with any "new" switcher it is strongly recommended that the output voltage be adjusted with at least a light load (a few hundred

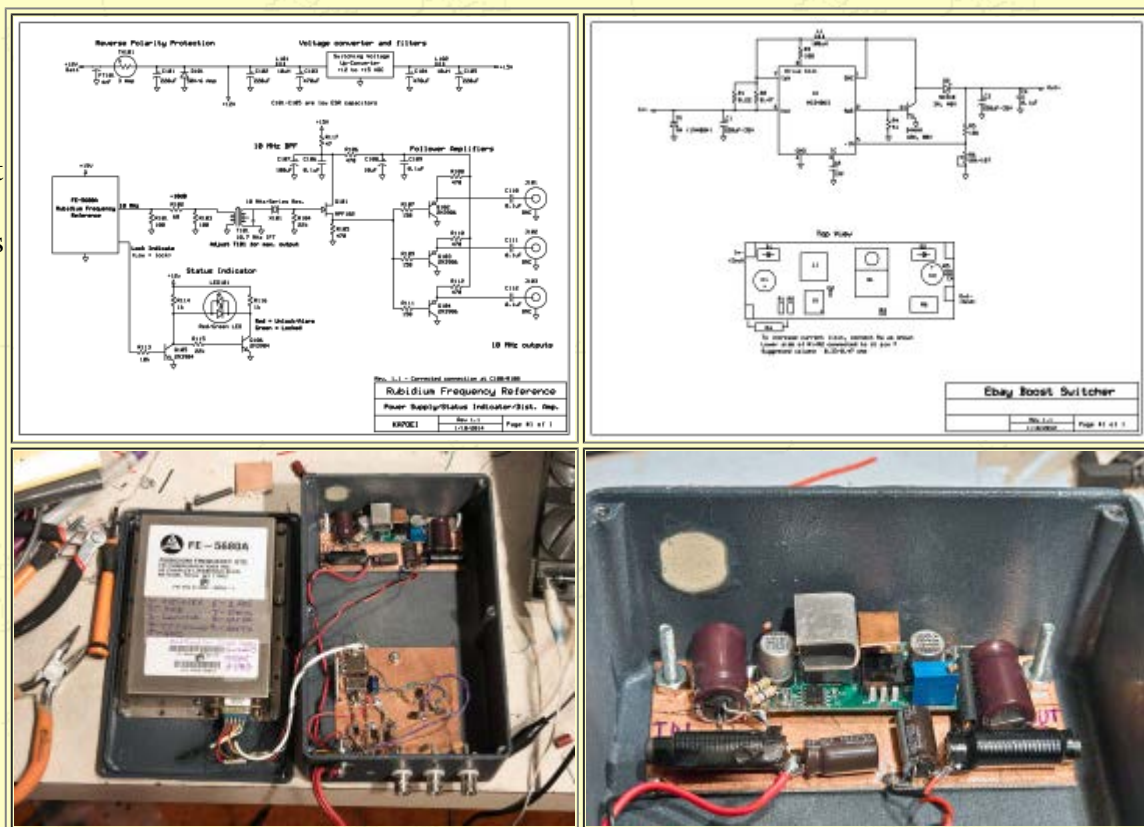

**Figure 2:**

**Top Left:** Diagram of the unit integrating the FE-5680A rubidium frequency reference showing supply protection/filtering, status indicator, and bandpass filter with distribution amplifier.

**Top Right:** Diagram and layout of the switcher used in the unit. Note the two paralleled 1 ohm resistors just to the left of the switch-mode controller chip just below the aluminum heat sink on the coil.

**Bottom Left:** Inside the 10 MHz rubidium frequency reference using the FE-5680A. On the left, mounted in the lid, is the FE-5680A and inside the box is the switching voltage converter (near the top) and the 10 MHz filter/distribution amplifier and status indicator near the bottom. It happens that this particular FE-5680A has a factory-installed 5 volt switching regulator - see below for more details. If it had not the internal regulator, I would have used a 7805 bolted to the box for the +5 volt supply. The lid of the die-cast aluminum box provides adequate heat sinking for the FE-5680A.

**Bottom Right:** Close-up view of the switching up converter along with its added input/output filtering.

**Click on an image for a larger version.**

ohms will usually do) **before** connecting it to what it is to power to verify proper, stable operation. *Note: Even with the period of current-limiting, the '5680A achieves lock in under 3 minutes at room temperature and is slightly faster than my LPRO-101.*

Because I was stressing the unit even more by increasing its output current capability and to improve reliability, I soldered a small piece of copper to the tab of the transistor (the collector) and epoxied (using "JB Weld") a piece of aluminum to the top of the inductor as seen in the top-right picture of **Figure 2**. The additional transistor heat sinking lowered its temperature and, by association, the temperature of the capacitor next to it. The heat sink on the coil is probably overkill but was done to help maintain the permeability of its core under all conditions as well as to keep the capacitor next to it a bit cooler. Since the circuit board was going to be enclosed in a box, the extra bit of heat-sinking seemed like a good idea.

### Power supply filtering:

Because of the very nature of switching voltage converters and the fact that it was to be used in an RF-sensitive application, additional input and output filtering was applied to the converter to keep switching energy from making its way into the FR-5680A or back onto the power supply bus. Being that this switching converter unit was very inexpensive I didn't trust the quality of the two capacitors on the board in the presence of high switching currents and elevated operating temperatures so off-board capacitors are added in parallel with them.

For additional filtering, 10  $\mu$ H inductors from a scrapped computer power supply and more Low-ESR capacitors were used to complete a low-pass C-L-C "PI" filter network, all being mounted "dead bug" on a piece of glass-epoxy circuit board. The switcher itself was solidly mounted to the same piece of glass-epoxy board using short pieces of #12 copper wire soldered to the "-IN" and "-OUT" leads and the ground plane itself. It's worth noting that the additional components may drop the voltage slightly (perhaps 100 mV) so it is a good idea to make sure that at least 15.0-15.1 volts is actually reaching the '5860A once it has warmed up.

For power supply bypassing, "Low-ESR" electrolytic capacitors were used and these types are **absolutely necessary** to provide reasonable filtering and good efficiency! Once construction was complete, the various components were mechanically secured in place using silicone (RTV) adhesive (applied after the picture was taken) to prevent them from moving around during transport and possibly breaking the leads.

As can be seen from the pictures, the switching converter itself is located as far away from the distribution amplifier as possible to minimize possible coupling into the 10 MHz output.

### Comments:

- This voltage converter was adjusted to 15-18 volts for use with the FE-5680A. The lower limit (close to 15 volts) is generally preferred as this produces less heat and consumes less power, but the higher voltage may allow it to achieve lock slightly faster from a cold start at the expense of higher overall power consumption.
- The FE-5680A, like many of these Rubidium units, consumes the most power when first started, cold, as the internal heater is at full power and once the unit warms up, the current will drop. As you might expect, the unit will consume more power in a cold environment than a warm one since the heater has to consume more power to overcome the heat loss. It should also be noted that a well heat-sunked unit will consume more current than one that is not heat-sunked, given otherwise identical conditions, but a non-heat-sunked unit will likely be thermally stressed as more of the circuitry will be exposed to higher temperatures, potentially reducing reliability. If minimizing power consumption was the goal, a semi-insulated unit on a good heat sink with a temperature/speed controlled fan might be appropriate to maintain a unit temperature that was neither too hot nor cool enough to cause more power to be consumed than necessary.
- Even though the converter depicted in Figure 2 goes into current limiting for 30-45 seconds when power is applied to a "cold" unit, it will still achieve lock in under 3 minutes at room temperature. Note that if the switching converter is adjusted for a higher voltage, it may take slightly longer for it to come completely out of current limiting.
- There are other pre-built voltage up converter units that may be found online - many of them based on the

LM2577. It has been noted that many of these units have far higher amounts of residual switching energy - either due to smaller-value filter capacitors on their inputs/outputs, board layout, or the use of higher-ESR capacitors. Because of this, it is recommended that an **additional** low-ESR capacitor be connected at the inputs and outputs of these units *and* a choke/capacitor be used to provide additional filtering on any unit that you might use.

- **Remember:** Any "grunge" that appears on the output of your frequency reference - which may come from the switching converter - may be multiplied **many-fold** at the local oscillator frequency, so good filtering and attention to layout is essential!
- It was noted that if subject to a mechanical shock, the 10 MHz output phase of the FE-5680A will "jump" and not return to its original position: ***Keep this in mind if it is going to be subject to vibration.***

As it happened, one of the two FE-5680A units that I got came with a factory-installed, on-board switching converter to produce the necessary 5 volt supply (pictured in **Figure 3** and discussed below) that only had to be connected by installing the appropriate jumpers. If your unit does **not** have an on-board switching converter and you are incorporating the unit into a larger box, it is recommended that an outboard 5 volt regulator (such as a 7805 bolted to the case in which you are mounting the '5680A) be used to minimize current consumption on the 15 volt bus as well as to reduce the amount of heat generated within the '5680A itself, but if you are adventurous - and the part of the board with the regulator is blank on your '5680A - details on populating this portion of the circuit board are included below.

### A "Go, No-Go" status indicator - refer to the diagram in Figure 2:

As noted, one of the several signals output by the FE-5680 is the "Physics Lock" indication - sometimes called the "BITE" (Built-In Test Equipment) line. This signal, when "high" indicates that an error condition is being detected by the unit's internal circuitry, that the unit is still warming up, it could also indicate that its supply voltage is too low, or that the unit itself has failed.

***Any time this signal is high, one should not trust frequency output of the unit to be accurate.*** While the unit is warming up its frequency output should slowly sweep back-and-forth around 10 MHz as it searches for lock from the "physics package" - a fancy phrase that refers to the magical Rubidium lamp and its associated circuitry. Once the lamp comes to temperature and it can detect an atomic resonance, it will suddenly "snap" to frequency and it should also be noted that ***until*** the unit locks, there will **NOT** be any output from the 1pps (1 pulse-per-second) output.

If this signal is high, Q105 is turned on which turns Q106 off allowing current through R114 to illuminate the **RED** portion of the dual LED, D102, indicating an "error" condition. If the "BITE" status signal goes low, Q105 is turned off, current through R113 to flow into the "green" portion of the dual LED and turn also on Q106 which, in turn, powers the green LED. ***This GREEN indication signifies that the unit is operating properly and can now be trusted to provide a reasonably accurate and stable reference.***

This diagram shows a 2-lead dual-color LED (red and green) but one may also use a 3-lead common-cathode dual-color LED as shown on the [LPRO-101 page](#): I used a 2-lead LED on this circuit because it was the first red/green dual-color LED that I happened to find when I opened the LED drawer.

At the instant that the LED turns green the 1 PPS output will go active and the frequency being output by the FE-5680A will be "only" within a few parts in 10E-8 but will rapidly stabilize, achieving good accuracy and will be "pretty darn close" in about a minute (*probably better than an already-warm quartz-based reference!*) and after 20-30 minutes it should achieve something close to its ultimate accuracy - assuming that it has been adjusted properly and that it is being operated under environmental conditions similar to those under which it was calibrated.

It's worth mentioning that if one were to remove power from the FE-5680A module itself, the BITE output would go low giving a false indication that the unit was working! This condition is pretty easy to diagnose as one or both of the following would be true:

- No 10 MHz output.

- If the LED goes green the *instant* that power is applied. Even if the power is interrupted briefly, it may take a minute or so for the '5680A to re-lock, so *seeing it go green immediately on the application of power and staying that way is a bad sign.*

### Power supply input filtering/protection:

Finally, the input supply is RF-bypassed using a feedthrough capacitor and FT101 to prevent the ingress or egress of extraneous RF along the power lead as well as conduction of switching supply noise along that same line - this, in addition to the L/C filtering on the input of the switching regulator. For power supply short-circuit and reverse-polarity protection, TH101, a 3 amp, self-resetting PTC fuse, is used in conjunction with D101 making the unit nearly fool-proof in the field.

### Distribution amplifier and 10 MHz filter for non-microwave applications - refer to figure 2:

#### Important note if you plan to use this for a microwave converter frequency reference:

- The crystal filter in the upper-left diagram of figure 2, above, is *not* narrow enough to clean up the output of the FE-5680A for use as a microwave frequency reference: Read about the [regeneration circuit \(below\)](#) for a means by which the '5680A may be used as such.

*If you want just a plain, simple distribution amplifier and don't want to mess with this crystal filter stuff or "clean-up oscillator" stuff, take a look at Figure 2 (above) or the diagram on my [LPRO-101 page](#) for some ideas.*

It had been reported that the 10 MHz output of the FE-5680A has a bit of off-frequency (non-harmonic) "grunge" on it so I decided to add some narrowband filtering as part of the multi-output distribution amplifier to clean up the FE-5680A's output since it was to be used as a frequency reference for microwave transverters. *As it turned out, this filtering was **NOT** enough to make it usable as a reference for at least 10 GHz and up and it is probably **not** even suitable to lock a 23cm transverter.*

#### How it works:

The 10 MHz signal from the FE-5680A is first terminated at 50 ohms and attenuated by a 10-ish dB pad consisting of R101-R103 before being applied to T101, a 10.7 MHz IF transformer, the Mouser 42IF129 with a 100 ohm input and 15k output impedance with a built-in (fixed) resonating capacitor. It was noted that this particular unit is no longer stocked by Mouser, but about any 10.7 MHz IF transformer with a built-in capacitor should work as most 10.7 MHz IF transformers will tune well below 10 MHz and above 11.5 MHz and using the resonant circuit, this simple crystal filter may be tuned to resonance by peaking the output level with the coil adjustment.

The high impedance side of the transformer is applied to a 10 MHz series-resonant crystal (the case of which is grounded) and terminated using R104, a 22k resistor which also provides a ground return for Q101, an MPF102 FET, a source follower. Because of the voltage gain of the transformer, the signal emerging from the source of Q101 will be of higher amplitude than on the input of T101, effectively amplifying the input signal. The output from the source follower is then buffered by independent PNP emitter followers Q102-Q104, each one being dedicated to a 10 MHz output through a blocking capacitor. Even though the port-to-port isolation isn't terribly high with this simple circuit, connecting/disconnecting loads on one output should have only a very slight effect on the others.

While the crystal filter removes frequency components *not* related to 10 MHz, not much attention was made to keeping the various follower stages in the linear range so the 10 MHz output waveforms are somewhat clipped, introducing harmonics. For most equipment this harmonic content is not a problem, but the circuit could be reworked (with a slight increase of complexity) to maintain a nice-looking sine wave on the outputs were this a priority.



Power supply filtering (R117, C107) assures that residual components from the 15 volt output of the switching supply will not find their way into the 10 MHz output. The 15 volt supply is used here to make the output level from the distribution amplifier insensitive to changes in the supply voltage.

#### Additional Comments:

- The "absolute" phase stability of the 10 MHz output was not considered to be particularly important. If the phase of the 10 MHz signal *is* important to your application it should be noted that the phase of the 10 MHz bandpass filter will be temperature-sensitive owing to the very nature of T101 and the crystal. It should also go without saying that any mechanical adjustment of T101 will cause a significant phase shift as well.
- As described, the bandwidth of this extremely simple and cheap 10 MHz crystal bandpass filter is on the order of +/-6 kHz at the -6dB points. If narrower response was desired for some reason, several crystals could be cascaded to make a Cohn-type filter, but filter construction is a topic that is best-covered elsewhere.
- Again, the described filter is *not* narrow enough to remove low-level spurs from the FE-5680A and make it suitable for use as a frequency reference for microwave transverters - *see below for a method of regenerating the 10 MHz signal.*

### Regenerating the 10 MHz output of the FE-5680A with a disciplined VCXO to make it suitable for use as a microwave transverter reference - see Figure 3:

After constructing the above 10 MHz distribution amplifier and crystal bandpass filter described above I did some testing and was disappointed to find that the low-level spurs on the 10 MHz output of the FE-5680A, when effectively multiplied by 1000 in frequency-locking the local oscillator of my 10 GHz narrowband transverter resulted in a signal that was *unsuitable* for narrowband (CW/SSB) use. For the most part, these low-level spurs are undetectable at 10 MHz or perhaps even 100 MHz, but the effective 60dB in amplification of these low-level signals made them both obvious and unacceptable when multiplied to 10 GHz.

As a basis of comparison I also checked it against three other 10 MHz sources: An HP Z3801 GPS reference, a [crystal-based reference using an Isotemp OCXO](#), and another [rubidium unit using an Efratom LPRO-101](#). Both crystal references (the Z3801 and Isotemp) were extremely clean and I think that there was just little bit of "digital sounding" noise on the LPRO-101 that I'd not really noticed before. It is worth mentioning, however, that the "long term" stability of the FE-5680A was fine and that the *actual* 10 GHz signal (*once located amongst the spectral clutter!*) was both stable and accurate.

At least some of the problem appears to be due to the fact that low-level noise from the internal synthesizer (*perhaps the DDS in the frequency control loop*) is making its way onto the output causing a fairly obnoxious "digital"-sounding buzz consisting of a number of fundamental frequencies and their harmonics - plus

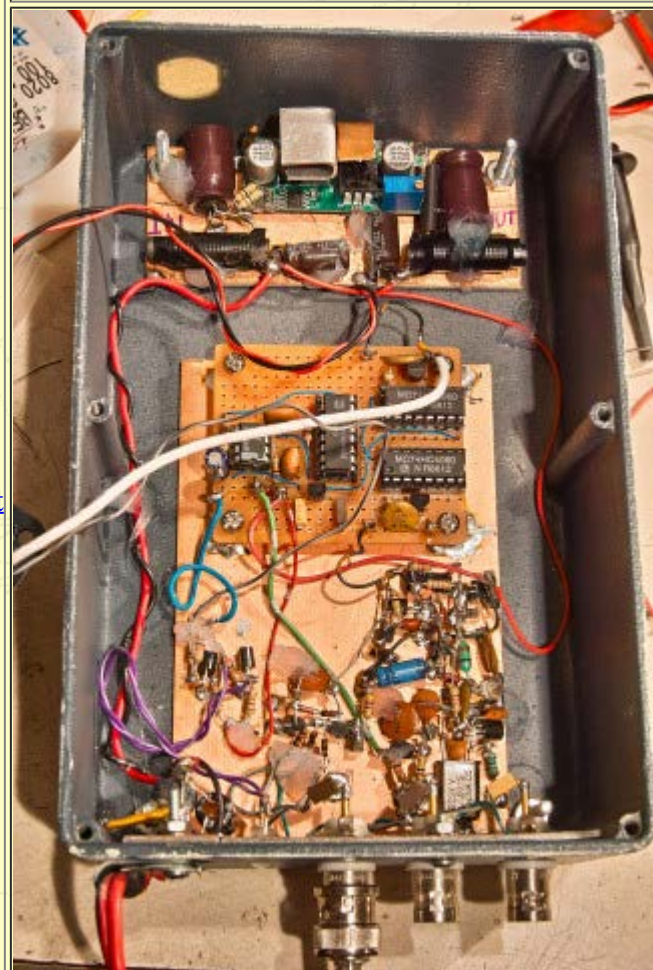
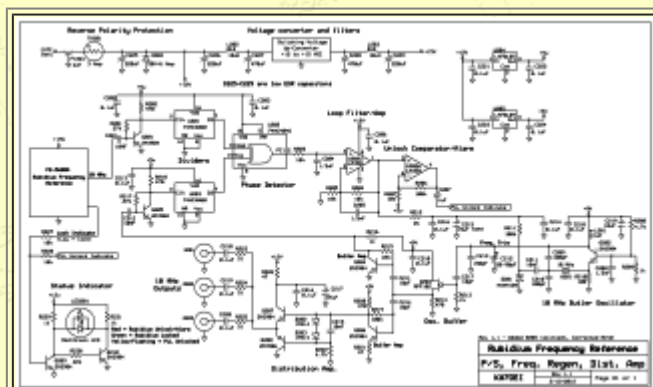

a fairly strong sub-audible component. The severity of this modulation when applied to a 10 GHz transverter - where the 10 MHz is multiplied 1000-fold - is enough that, when SSB is used, its presence actually makes it a bit difficult to properly zero-beat a carrier. To find out had "bad" it is, read the article, [Performance of Low-Cost Rubidium Standards](#) by John Ackerman, N8UR.

Because of the very low frequency nature of some of these components it was deemed impractical to filter them directly at 10 MHz so the design goal was to "loosely" lock another 10 MHz oscillator to the output of the '5860A. In this way the frequency stability of the '5680A could be inherited by the other oscillator but its undesirable traits would not.

### **10 MHz VCXO:**

The heart of this is a low-noise oscillator consisting of Q202, X201 and associated components forming a Butler oscillator and it is this circuit that ultimately determines the phase noise of the microwave oscillator once it has been multiplied. As it turns out, this oscillator is comparatively insensitive to capacitance when tuning and it was required that D201, the varactor, be a high-capacitance "Hyperabrupt" type (MVAM109, NTE618 or equivalent) with about 400 pF at 1 volt and less than 100 pF at 10 volts, providing about 300 Hz of tuning range - more than enough to compensate for the temperature-related frequency changes of the oscillator's crystal. It should be noted that for this type of oscillator, a series-resonant crystal is required or there will be a significant frequency error.

It is possible that this oscillator could be reworked to increase the tuning sensitivity in terms of capacitance and allow a lower-capacitance varactor to be used but care should be taken to avoid excess sensitivity to the "capacitive environment". When initially constructed there was some concern that the varactor itself could be the cause of additional phase noise, but a comparison with of the cleanliness of the CW note (at 10 GHz) between a free-running oscillator *without* the varactor and with the circuit (with varactor) locked to the FE-5680A and also to one of the other known-good 10 MHz sources mentioned above didn't reveal any obvious difference.

In the prototype, a cheap (<\$1.00) CPU-type 10 MHz crystal was used and these inexpensive devices tend to have rather poor frequency accuracy and temperature stability. If a high grade crystal (typically \$10-\$20) had been used it is likely that both temperature stability and frequency accuracy would have been improved, allowing a somewhat relaxed VCXO tuning range and, perhaps, somewhat better phase noise performance with increased crystal "Q" - although all of these could probably be accomplished with more careful design of the oscillator itself, even with the "cheap" crystal. Another benefit of a "better" crystal with a lower temperature drift would be that D201 could be replaced with a lower capacitance and/or back-to-back varactors which could further reduce contribution to phase noise.

If one has a good quality 10 MHz VCXO available it may be used to replace the oscillator shown, but be aware that many low-cost VCXO DIP or SMD modules often have rather poor phase noise and just aren't suitable for narrowband (e.g. SSB/CW operation) when multiplied 1000 times. If one has the room and doesn't mind the extra power consumption, an OCXO with external (electronic) tuning may also be used, but this would probably be overkill, consume more power, take longer to warm up than the rubidium and generate even *more* heat.

### **Buffer and distribution amplifier:**

Q203, a source follower, takes a sample of the oscillator's output to minimize loading effects with Q206 providing some gain and Q207 and Q208 forming a complimentary driver voltage source with resistors R223-R225 setting the source impedance and driving multiple outputs. While only three outputs are shown, testing showed that it would easily drive half a dozen 50 ohm loads. The isolation between these ports isn't terribly high (perhaps on the order of 20dB) but it is unlikely that there will be much interaction between outputs and what effects there might be would likely occur only at the instant other devices were connected or disconnected. Since this was intended to feed the 10 MHz inputs of microwave transverters, there wasn't the fanatical need for phase/amplitude stability under all operating conditions or even very high port-to-port isolation.

With the amplification circuitry shown, the fidelity of the reasonably "clean" sine wave from the oscillator isn't

### **Figure 3:**

**Top:** *Diagram of the 10 MHz regenerator, distribution amplifier, status indicator.*

### **Bottom:**

*The above circuit as built into the enclosure with the FE-5680A.*

**Click on an image for a larger version.**

terribly well-preserved, but it's much more "sine-like" than square. As it happens, a waveform with harmonically-related content isn't likely to cause a problem with the 10 MHz input on synthesizers used in microwave gear and test equipment, but what *can* be a problem is if the waveform is very "ringy" - something that can happen with square-ish waves as the device could erroneously "see" the ringing portion of a waveform, falsely trigger on it, and causes errors - but this unit's waveform wasn't at all "ringy."

### ***PLL:***

Q204 and Q205 amplify the VXCO's output to logic levels feeding it to U203, a 74HC4060 binary ripple counter that reduces comparison frequency and loop gain and provides the square wave required for optimal operation of an XOR-type phase detector while a similar amplifier and divider consisting of Q201 and U201 form a divider chain with this counter's output - and that of U203 - being phase compared by U202, a 74HC4046. In the '4046, only the XOR gate phase comparator is being used and the comparison frequency output is filtered using R203 and C204 and then amplified (and filtered) by U202a and C205/R204 to a 0-10 volt level and applied to the VCXO tuning line through R211 being further filtered by C214-C216 to set a fairly low loop bandwidth. A pair of '4060-type counters were used because I had plenty of them on hand and also because the multiple divider taps allowed by to try different comparison frequencies.

A pair 74HC4040 counters could have been used (with appropriate wiring changes) or even a single 74HC4520 - which I would have used if I'd had one onhand! If you happen to need 5, 2.5 or even 1.25 MHz outputs for some reason (such an input to test equipment) then one could take a sample of one of the divider's outputs (especially in the case of the '4040 or '4520), buffer it and use it, but make sure you use the counter connected to the output from the crystal oscillator and not the rubidium.

Because of the nature of the XOR-type phase detector, the "tuning sense" (e.g. whether increasing tuning voltage causes the frequency to go up or down) or even which signal input (VCXO or Rubidium) is connected to the divider inputs at Q201 or Q204 is irrelevant: If the tuning goes the "wrong way" the waveform on the XOR phase detector will simply "slide" 180 degrees and invert itself. The '4046 also contains other phase/frequency detectors, but the advantage of the XOR fed with square waves is that its output can *never* contain any spectral components that are lower than that of the comparison frequency - and it usually outputs energy at twice that! In comparison, the flip-flop phase/frequency detector in the '4046 (the so-called "PC 2" detector) has the nasty habit of, when in lock, bouncing around at a relatively low frequency which may *not* be easily removed by a loop filter.

I could also have used a 74HC86 quad XOR gate instead of the 74HC4046 as the phase detector. If this had been done, two of the three "extra" gates might have been usable as "gate amplifiers" to bring the two 10 MHz inputs up to "logic level" instead of using Q201/Q204: I've done this in the past with good results but I didn't do it for this project because I wanted to play around with the other phase detectors on the 74HC4046.

It is worth noting that the simple PLL/loop filter shown (*e.g. a non-integrating type*) does *not* have a constant phase relationship between the '5680A and VCXO signal when locked, but that is not important with a relatively stable oscillator when used only as a frequency reference for microwave transverters. Finally, the loop design itself was intended to be fairly "insensitive" and slow because we wanted to pass on the stability of the FE-5680A's output to the 10 MHz VCXO, but as little of the low-level, low-frequency phase noise that afflicts it as possible.

### ***PLL Lock indicator:***

One of the difficulties with using an XOR-type phase detector is that an "unlocked" condition is more difficult to detect than with a more complicated phase detector, so this circuit takes advantage of the fact that if the PLL is *not* locked up the XOR's output will "flap" back and forth between high and low at a rate related to the difference between the frequencies of the VCXO, the rubidium, and the divisor ratios used. U202b is a comparator that "looks" at the tuning voltage output from U202a and as it crosses the threshold voltage - the "middle" of the tuning voltage range - the comparator "snaps" back and forth in unison. This output is capacitively-coupled (via C207) and then via R228 so if the PLL is unlocked, the voltage changes from 0 to V+ as the phase comparison inputs to U202 "slide" past each other and cause the status indicator to switch rapidly back and forth between red and green, providing a visual indication that the PLL is unlocked by causing the LED to flash/flicker or - if the frequency is way off, turn orange/yellow when both the red and green appear to the eye to be illuminated simultaneously.

The only peculiarity with this circuit is that if the PLL tuning voltage happens to cross U202b's threshold during normal operation, the status indicator may flash, but this should happen rarely and it will have no effect at all on the 10 MHz output. Because the cost of implementing this lock indicator was very low (requiring only a few inexpensive components, utilizing the "unused" op amp section and the existing status indicator) this minor deficiency can be overlooked.

Note that the PLL may be unlocked while the rubidium unit is warming up and its output frequency is sweeping back and forth, possibly out of the lock range of the "clean-up" VCXO so it wouldn't be unusual to see this LED turn yellow or frequently flash red.

### ***Go, No-Go indicator, voltage converter and power supply filtering:***

Aside from the addition of the PLL unlock indicator to the "go, no-go" circuit, the operation of the voltage converter and power supply filtering are identical to that shown in figure 2 - in fact, the original crystal bandpass/distribution amplifier board was simply replaced with the new board that regenerates the 10 MHz.

### ***Additional comments:***

- If one is planning to use the 10 MHz output of the FE-5680A for precise timing rather than a frequency reference it is worth noting that the "absolute" phase of the regenerated 10 MHz output will be affected by temperature, but at a slow enough rate that the frequency shift - even at microwave frequencies - is not likely to be detectable. If both a "clean" 10 MHz signal suitable for multiplication and a phase-stable signal were required, the two could be taken independently.
- As can be seen from the pictures, the oscillator and amplifier portions were built "dead-bug" on a piece of glass-epoxy circuit board while the "digital" portions and the PLL filter were constructed on a piece of perforated proto board. It is possible that a circuit board could be designed on which both circuits could reside, but I have no current plans to do so. *If you want to do it, let me know so that the design can be shared with others who might be interested!*
- There are more comments on using this "cleaned up" signal on microwave transverters, below - [click here](#) to jump directly to that section.

---

### ***Using an internal 5 volt supply with the FE-5680A:***

The "non-programmable" version of the FE-5680A typically requires that a source of +5 volts be supplied externally via pin 4 of the DE-9 connector - this typically being provided by the user via a 7805 linear regulator - without which, the unit will not function.

Upon receipt of two "identical" FE-5680A's, I opened them up and noticed an obvious difference: One had components installed for an internal 5 volt switching regulator and the other did not. Interestingly, even though the components were fitted on one of the units, *neither* the input or output of the +5 volt regulator was connected. A bit of poking around with an ohmmeter revealed to me that it was necessary to install two jumpers to enable this supply, making the FE-5680A an entirely self-contained unit - *see Figure 4 for the location of those jumpers.*

On the "other" unit I simply soldered a 7805 to the ground plane in the area in which the switching supply components were fitted. I then applied heat-sink grease to the case of the 7805 and also the insulating sheet to transfer at least *some* of the heat generated by it to the bottom plate and wired jumpers to the V+ input of the regulator from the 15 volt line and the 5 volt output of the to pin 20 of the 74ACT240 nearby. Testing indicates that with the bottom plate heat-sinked, the unit does not run "excessively" warm.

### **Comment about using an on-board linear regulator and heat generation:**

- **It should be noted** that if the unit needs to be entirely self-contained, the addition of an internal linear regulator makes sense. If, however, you are going to include the '5680A in another project, an external 5 volt

supply would be better as it wouldn't contribute to internal heat generation and less power would be wasted as the 7805 could be powered from a lower-voltage supply. *In other words, if you are going to convert from 12 up to 15 volts, it would be better to run the 7805 from the 12 volt supply instead of the 15 volt supply.*

## Installing components for the on-board 5 volt switching regulator:

### Warnings:

- *I have NOT done the modifications suggested and I strongly suspect that there are one or two other jumpers that need to be installed/changed.*
- **This information was obtained through the use of an ohmmeter, data sheets, some measurements, and a bit of guessing and is probably mostly correct.**
- *Use of this information will be at your own risk! If you are successful in performing these modifications - or even if unsuccessful - please let me know!*

Poking around the two FE-5680A's that I have, I have divined a bit of information as to what it might entail to install the necessary components to allow the use of the internal 5 volt switching regulator.

**Figure 4 - middle-left** shows what the populated 5 volt regulator looks like - all components being located within the border of the ground trace. Based on the Linear LT1376 regulator, this efficiently (90% or so) converts the 15-18 volt supply voltage down to the +5 volts required for proper operation while producing only a small amount of extra heat to be dissipated by the unit.

**Figure 4 - lower left** shows what is believed to be the diagram of the switching regulator with the picture in **Figure 4 - middle right** being an annotated version of the picture showing the locations of the installed components. While some of the components in the schematic are noted on the board's silkscreen, some are not and those are indicated using "a" and "b" designations.

### Component comments:

- **U504** is an LT1376HVIS - the "adjustable" version with the output voltage selected using resistors Ra and Rb. If a "5 volt" version of the LT1376 is used one may omit both Ra and Rb, jumpering the Ra position with a piece of wire. Note that this chip is available in several different packages and it is the **16 pin** version that is required for this application.
- **L500** is believed to be a Coilcraft DO33088-153 15uH, 1.9 amp (RMS) SMD coil.

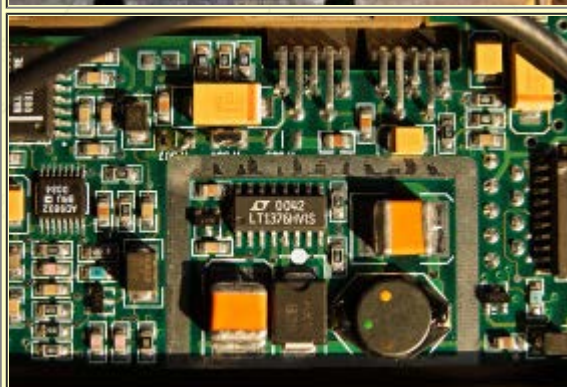
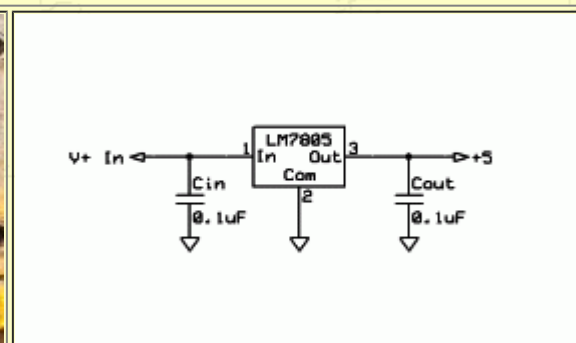
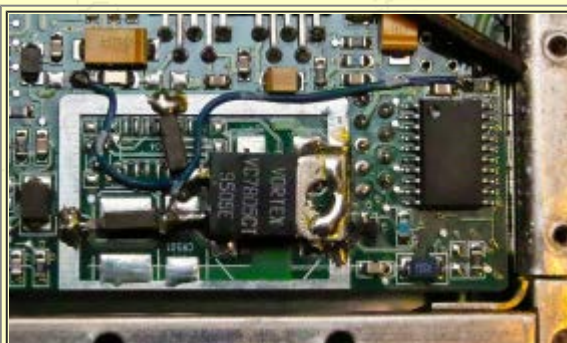

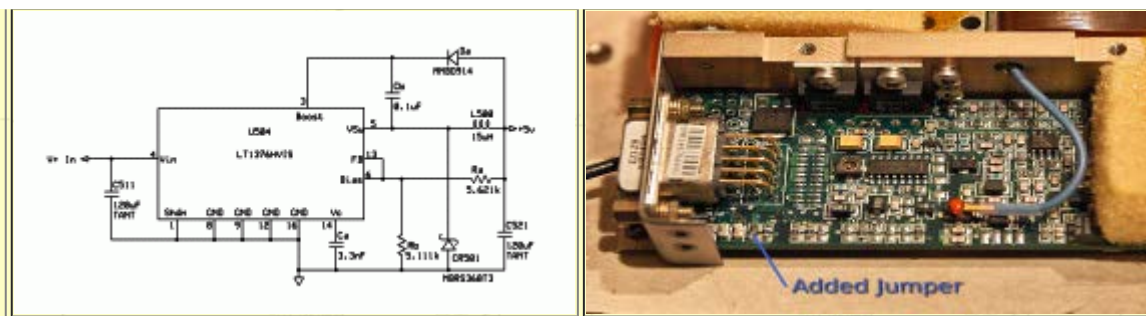

**Figure 4:**

**Top left:** Close up of the details in soldering and wiring a 7805 inside the FE-5680A, the tab being soldered to the ground plane for heat sinking. Heat sink compound was put on the case of the 7805 and the insulating sheet to more-effectively transfer heat to the bottom cover. The input voltage comes from the jumper on the left and the +5 volt output connects above the 20 pin chip on the right.

**Top right:** Yes, it's just a 7805 and two capacitors!

**Middle left:** Close-up of the board showing the section (within the ground plane) containing the components of the 5 volt switching regulator.

**Middle right:** The same picture, annotated with the parts designations used in the schematic. Also note the added jumper indicated - see text and warnings!

**Bottom left:** Believed to be the schematic of the regulator.

**Bottom right:** Another jumper that was required to be installed on the "top" of the board to enable the 5 volt regulator - see text and warnings!

**Click on an image for a larger version.**

This particular coil has a somewhat larger footprint than most coils of similar type but a smaller unit could be used if care were taken to avoid shorting to the ground plane beneath. The main requirements of this coil are that it be capable of handling the current and protrude only about 3-3.5mm above the board in order to clear the lid. Inductor values of 10-20uH should be usable in this application.

- **CR501** is an MBR5360T3 60 volt, 3 amp Schottky diode.
- **C511, C521:** The most critical components are C511 and C521 which are both 120 uF, 20 volt solid tantalum capacitors, Vishay P/N 594D127X0020R2T (Digi-Key P/N: 718-1007-2-ND). Note that because this switcher operates at about 500 kHz and is in an RF-sensitive environment, one **CANNOT** use electrolytic capacitors in this application! It should be possible to use high-value ceramic chip capacitors (*one or more units to add up to 100 uF*) but one must keep in mind the component height requirement! Looking closely at the picture you'll note that these particular capacitors have a "point" that indicates the positive lead.
- **Da** is a surface-mount 1N914 - nothing special: About any reasonably fast silicon diode with a >40 volt rating at >50 mA should be suitable.
- **Ca** and **Cb** are standard chip capacitors in 0805 packaging.
- Resistors **Ra** and **Rb** (0805 packaged devices) are used to set the voltage output. The values noted in the schematic are those on the board but one can reference the LT1376 data sheet for other values. As noted above, if a 5 volt version of the LT1376 is used one may omit both resistors and simply jumper the Ra position.

#### Additional comments:

- As noted, there are at least two jumpers (shown in Figure 4) that needed to be installed on the unit that already had the switcher's components installed in order to power it up. It is unknown, however, if the "unpopulated" board will require these same jumpers, require that some existing jumpers be removed or additional jumpers added. What would be "safe" to do, however, would be to simply connect a jumper wire to the positive side of C511 from the V+ input of the unit (or from the jumper position depicted in the **upper-left** picture in **Figure 4**) and connect pin 20 of the nearby 74ACT240 (at the junction of the two capacitors as shown in the same picture) to the converter's V+ output at C521.

#### "Tweaking" the frequency:

As noted, the version of FE-5680A depicted on this page is the "non-adjustable" type, so-called because unlike *some* versions, the output is "fixed" at 10 MHz rather than adjustable from audio frequencies (*if the unit is appropriately modified*) to around 20 MHz in sub-Hertz steps. The "adjustable" units have a simple user interface via the serial port that produces human-readable results, more or less.

The version used above has its output at 10 MHz and it, too, has the ability to be controlled via the serial port, but the output frequency (10 MHz) can be tweaked in steps of several parts in  $10E-13$  with a total range of well under 1 Hz. Unlike the command set in the "adjustable" version, the command bytes cannot easily be entered directly by the user so a program has been written to do this. The format of the commands to control this version of the FE-5680A are detailed in the [FE-5680A technical manual](#), available from the [VK3UM page](#) with the program itself, written by VK4XV, being [linked here](#).

Having a known-accurate frequency reference (an HP-Z3801) available, I compared the 10 MHz output of the FE-5680A with that of the Z3801 and, using a dual-trace oscilloscope, found that it took about 6 minutes for the relative phases to change by 360 degrees once the unit had been operating for an hour or so. Firing up the program, I read the offset that had been programmed into the FE-5680A (from either the factory or the previous owner) and found it to be set to zero. Using the program, I did a "binary search" by first selecting rather large offset values to determine which polarity of offset (positive or negative) reversed the direction of the offset and then started cutting those values in half, always staying on the side of reduce rate-of-change of the phase change. Once this value is found, one may write the value "permanently" into the unit and ***it is recommended that his number be written (in indelible ink) on the unit itself for future reference.***

To be sure, at single-digit offsets I used the scope's maximum magnification and it took several minutes to see the very slow rate-of-change which was, when I was done, about 80 minutes for 360 degrees ending up with a final offset value of +190 for this particular unit. I repeated the same procedure for another FE-5680A and ended up with an offset value of -384, but this unit's sensitivity seemed to be a bit higher per-step and resulted in a 360 degree change over about 20 minutes. It was interesting to note that in both cases, the units arrived with an offset of **zero** indicating that whoever used them was satisfied with the "out-of-the-box" accuracy of the units.

One caveat with the current version of the VK4XV program is that **it does not automatically fill in the "offset" value to be entered in the unit with that already programmed into it** - even if you read the currently-programmed values from the '5680A. What this means is that the field you enter will *always* be zero and one must decipher the HEX values displayed and convert them to decimal to determine what the current offset is. Again, the easiest way around this is to keep notes and, using an indelible marker, write the final offset on the unit's label when done.

## Observations of the phase stability of the FE-5680A:

*The observations below were made using an oscilloscope triggered from an HP Z3801 GPS-locked frequency reference.*

While I was at it, I decided to take a look at how changes in voltage affected the output of the FE-5680A and noticed that changes in voltage within the allowable range (15-18 volts) caused a noticeable shift in phase - as did a rapid change in temperature. Longer term, these changes did *not* cause a large offset in the stability of the unit (at least as far as I was concerned as a microwave band operator) but rather it seemed as though these were, in fact, just shifts in the phase of the output. When these changes were "un-done" it appeared that the phase moved back to where it had been - taking into account the unit's frequency offset, of course.

Poking around, I noted that the heated crystal within these units appeared to be the cause main of these phase offsets: A change in temperature of this crystal seemed to cause a repeatable phase shift and it is likely that the power applied to the heater attached to the crystal itself changes slightly as the input voltage changes. This observation also seemed to explain, at least in part, why a change in temperature of the unit also caused a phase shift.

These observations indicate that if phase stability is important to you, the operating voltage of the FE-5680A should be well regulated and the temperature remain constant. In my case - where I will be using the FE-5680A as a precise 10 MHz reference - the slow phase changes (which would correlate with small frequency offsets at microwave frequencies) that would accompany temperature changes are less important, representing only a few Hz of error at GHz-range frequencies.

I also noted that a gentle (but firm) tapping of the either of my FE-5680's caused "permanent" jumps in the phase of the 10 MHz output on the order of 10's of degrees - probably from an oscillator/counter comparison "slipping some

cogs" internally in response to microphonics. While not likely to be an issue for those units sitting on a shelf somewhere, those units being exposed to vibration (such as in a car) may suffer brief "jumps" in frequency. The LPRO-101, by comparison, did *not* seem to be fazed by any physical abuse I dared inflict upon it.

Comparing the FE-5680A to the LPRO-101, I find the former to be somewhat inferior in its susceptibility to changes in its physical environment and operating voltage, but this is just my perception. As far as holding their adjustments under similar conditions, they seem to be comparable. The FE-5680A (unmodified) has its fine adjustments made only via the serial port while the LPRO-101 has an onboard potentiometer and an external "C-Field" lead to allow disciplining and/or environmental compensation and when it comes to making very fine adjustments, it is far easier to "tweak" the FE-5680A to "dial in" the frequency via computer than to adjust the potentiometer in the LPRO-101 where one doesn't have as good a "feel" for the magnitude of the adjustments that one is making.

To re-reiterate, the output of the FE-5680A is *NOT* directly suitable for use as a frequency reference for microwave transverters due to low-level phase noise - particularly when frequency multiplication worsens its effects. As noted above, an outboard crystal oscillator "disciplined" by the the FE-5680A using a circuit such as that described by Figure 3.

## Using the "cleaned-up" FE-5680A on the microwave bands - some observations:

As noted above, the "barefoot" FE-5680A is *not* suitable for use on the higher microwave bands (e.g. above 1 GHz) owing to the multiplication of low-level phase modulation, hence the building of the "clean-up" oscillator. On the lower VHF/UHF bands (e.g. 2 meters, 70cm) the "raw" output of the '5680A should be "OK" - if you have equipment that uses a 10 MHz reference input, that is! Many hams have modified commercial gear to frequency-lock the radio's reference to an external 10 MHz source and these circuits may (or can be made to) be able to adequately filter any low-level "grunge" that might appear on the reference input, anyway.

In testing the '5680A with the above "clean-up" oscillator on 10 GHz SSB I found it to be quite usable - although there was a slight amount of "warble" that appears to be due to low-frequency instability that was proportionally worse on 24 GHz SSB. The cause of this has yet to be traced out just yet, but a few possibilities come to mind:

- **Low "Q" of the cheap 10 MHz CPU-type crystal that was used.** This crystal was less than \$1, so I wasn't expecting it to work perfectly. If I were to replace it with a higher quality (\$20-\$30) crystal I would expect that it might perform better because it would have better characteristics, including better "Q" and temperature stability.
- **Too much VCXO frequency control.** As noted, I wasn't terribly happy with the amount of capacitance required to achieve the amount of VCXO voltage tuning required to assure that the crystal oscillator would be in range over a wide variety of temperatures and this required the use of a "hyperabrupt" varactor. More ideally, back-to-back varactors would be used to minimize the effects of a single varactor's impact on phase noise, but this was not possible while still keeping the desired tuning range. It is possible that a re-working of the capacitor/inductor values in the crystal oscillator will allow a reduction of the amount of varactor capacitance required. What would *really* help, however, would be the use of a higher quality crystal so that far less electronic frequency control range would be needed and the lower voltage-versus-frequency sensitivity would thereby minimize any contributions of low-level, low-frequency phase modulation that might be coming from the phase detector and amplifier.
- **1/f noise from the op amp/phase detector.** As one approaches DC, there is an increase in the random noise from electronic circuits and it is likely that very near DC, the phase detector and/or op-amp is contributing to the low-frequency warble because of this. By re-working the phase detector and, perhaps, using a "quieter" op amp the warble may be reduced. The better solution to this would be to use a better-quality crystal as mentioned above as this would reduce the required tuning capability which would therefore make it less sensitive to low-frequency "noise" on the tuning line.
- **1/f noise from the voltage regulator.** I need to look into this, but in the past I've observed that 3-terminal regulators (such as the 7805) can produce a bit of low-level noise on its output - which could then find its way



into everything else. Again, using a better crystal and reducing voltage-frequency tuning sensitivity would probably be the best solution.

- **A better oscillator!** It should be possible to find a decent, off-the-shelf VCXO or OVCXO that has good, low phase-noise characteristics. I found an inexpensive ovenized miniature 10 MHz oscillator (with electronic tuning) on EvilBay that is known to be good when multiplied to 10 GHz and above that I will try some time. The obvious downside is that not only would this increase the power consumption, but it would likely lengthen the "lock-up" time of the entire reference from the normal 3 minutes of the '5680A alone to 5-10 minutes - this, depending on the warm-up time of the chosen oscillator.

### *Other links pertaining to Rubidium references:*

- [FE-5680A FAQ at KO4BB](#) - This page has a lot of links and useful information about the various incarnations of the FE-5680A in one place. If you are having trouble getting your '5680A working, you *should* take a look! For more about precision timing and many other things, take a look at [KO4BB's Wiki](#).
- [My page about the LPRO-101](#) - A suspiciously similar page that describes a box built around the Efratom LPRO-101. Almost everything on the LPRO-101 page could be applied to the FE-5680A and vice-versa, the only difference being that the FE-5680A is happy with +15 volts while the LPRO-101 needs at least 19 volts.
- [Information about the FE-5680A from VK3UM](#) - That page has information on *THIS* version of the FE-5680A, including a link to the program used to tweak the output to precise frequency.
- [Operators manual for the LPRO-101](#) - This contains useful information on the hookup and operation of one of these units.
- [Rubidium reference information at KO4BB](#) - More useful information related to this and other Efratom Rubidium references - including repair and adjustment. *Click on section 5, "GPS Timing"*
- [Rejuvenating Rubidium Lamps](#) - The rubidium lamp in these devices has only a finite lifetime, but this page explains how you *may* be able to get more life out of it if it quits working! Note that while this page doesn't address the FE-5680A specifically, the same general technique *may* be applicable.
- [The "Time Nuts" Mailing list and archive](#) - Covering all sorts of nerdy topics related to frequency and time measurement, the archives of this list contain a wealth of information about this and other frequency references. While anyone may peruse the archives, you must join the list in order to participate.
- [Performance of Low-Cost Rubidium Standards](#) by John Ackerman, N8UR - This article compares a number of low-cost (e.g. surplus) rubidium units to determine best short and long-term stability. From this article, one sees why the FE-5680A by itself does *NOT* make a good reference for microwave transverters! The winner among Rb's? The Efratom LPRO-101.
- [Stability and Noise Performance of Various Rubidium Standards](#) by John Miles, KE5FX - Another excellent article comparing the important parameters of various Rubidium devices available on the surplus market. From this page you can readily see why the LPRO-101 works "barefoot" as a microwave reference and an FE-5680 does not!

### *The usual warnings:*

- *As with any electronic project, anything described or referenced above should only be done by those familiar with the techniques involved.*
- *Please observe all safety precautions when dealing with voltage, heat, or potentially dangerous materials such as Rubidium.*

***You have been warned!!!***

***[Return to the KA7OEI Microwave page.](#)***

***Any comments or questions? Send an [email!](#)***

***This page and its contents copyright 2012-2016 by Clint, KA7OEI. Last update: 20160720***

***Since 1/2012: 61,537***