

Attenuator Amplifier Design to Maximize the Input Voltage of Differential ADCs

Keyur Tejani

ABSTRACT

This application report describes the challenges faced when attenuating large signals for digitization and provides solutions for converting a large single-ended input signal to a differential signal sampled by an ADC.

Contents

1	Introduction	2
2	Analysis	2
3	TINA-TI Simulation	6
4	Summary.....	7
5	References	7

List of Figures

1	High Gain versus Attenuating Signal Chains	2
2	Attenuator Fully Differential Amplifier Configuration	2
3	Hi-Z Signal Chain With an OPA2810 Buffer Stage.....	3
4	Hi-Z Signal Chain With an OPA192 Buffer Stage	3
5	$V_{IN,CM}$ Waveform Based On Equation	4
6	THS4561 TINA Circuit and Simulated Results.....	6

List of Tables

1	THS4561 versus THS4551 Power-Supply and Common-Mode Input Range	5
2	Attenuation and $V_{IN,CM}$ Results for Configurations in and	5

Trademarks

All trademarks are the property of their respective owners.

1 Introduction

Data-acquisition systems and digitizer front-ends are often paired with high-sensitivity sensors that produce low-level output signals (for example, measuring the voltage drop across a low-resistance shunt to measure the current in the circuit). In such cases the amplifier signal chains are configured in high-gains to maximize the dynamic range of the ADC. High-precision, differential input ADCs such as the ADS89xxB and ADS9110, ADS9120 from Texas Instruments are typically limited to a maximum recommended supply of 5 V and a corresponding maximum differential input range of 10 V_{PP} when the reference voltage (V_{REF}) is set to 5 V.

However, In high-power industrial signal chains, the input signal to the system can be much larger in which case the amplifier signal chain must attenuate the signal input down to the acceptable input range of the ADC. **Figure 1** shows a simple illustration of the difference between a low signal input and high signal input ADC front end.

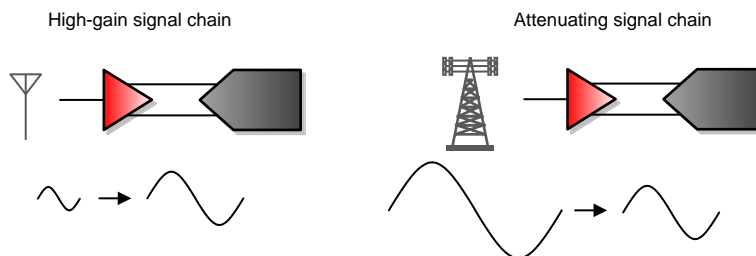

Figure 1. High Gain versus Attenuating Signal Chains

In signal chain designs like these, there are many factors to consider such as bandwidth, slew rate, distortion, and power but the two factors we will discuss in this article are:

1. Attenuating the signal to within the ADC input range
2. Choosing a fully differential amplifier (FDA) for the ADC driver stage that maximizes the input signal range of the ADC

The analysis presented in this document assumes a single-ended input to differential-output because this scenario has more stringent requirements compared to the differential-input to differential-output scenario. Assume the FDA feedback resistors (R_F) and the gain resistors (R_G) are the same for each half of the FDA.

2 Analysis

Figure 2 shows a typical single-ended to differential attenuator configuration using an FDA. For high-power industrial data acquisition systems that need high input impedance (Hi-Z), low input bias current (pico-amps typically) and rail-to-rail input and output devices such as the OPA2810 (27-V, 70-MHz GBW) and OPA192 (36-V, 10-MHz GBW) from Texas Instrument are commonly used in a buffer configuration in front of the differential amplifier. **Figure 3** and **Figure 4** illustrate the high input impedance signal chain using the OPA2810 and OPA192, respectively.

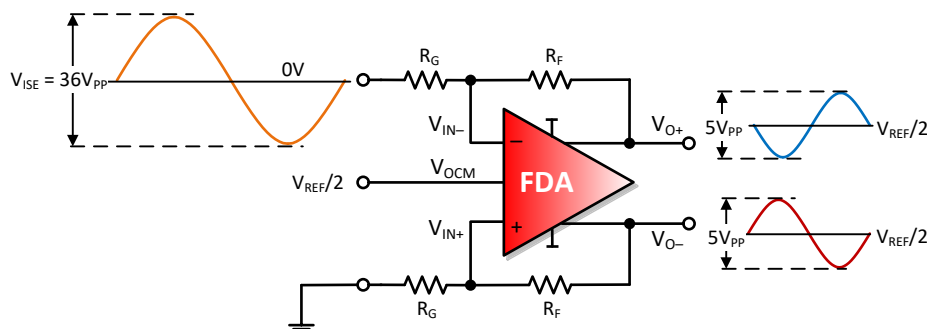

Figure 2. Attenuator Fully Differential Amplifier Configuration

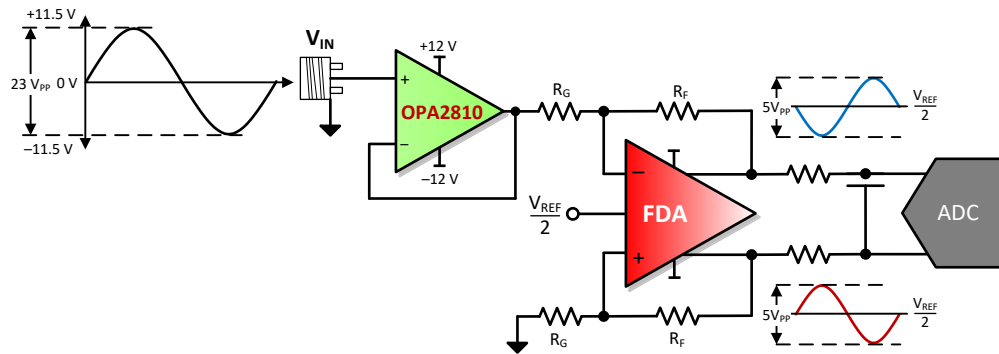

Figure 3. Hi-Z Signal Chain With an OPA2810 Buffer Stage

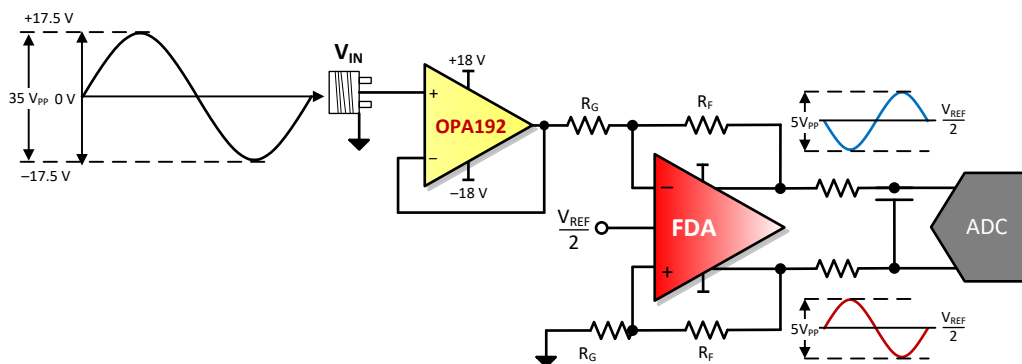

Figure 4. Hi-Z Signal Chain With an OPA192 Buffer Stage

2.1 Signal Chain Requirements

First we will discuss the differential amplifier parameters to consider when attenuating the signal to within the ADC maximum input range, as shown in Figure 2. This attenuating signal chain is sometimes referred to as a funnel signal chain because the signal is narrowing as it goes through the driver stage of the ADC. Equation 1 shows the relationship between the single-ended input signal and the differential output. The common-mode at each output, V_{O+} and V_{O-} , is set to the voltage forced on the V_{OCM} input ($V_{REF} / 2$ in the example in Figure 2) because of the inherent properties of the FDA.

$$\frac{V_{ODIFF}}{V_{ISE}} = \frac{V_{O+} - V_{O-}}{V_{ISE}} = -\frac{R_F}{R_G}$$

where

- V_{ODIFF} = Output differential voltage
- V_{ISE} = Input single-ended voltage

(1)

Because this input configuration is single-ended, an important factor to consider in the design is the common-mode voltage at the inputs, V_{IN+} and V_{IN-} , of the FDA. The common-mode input voltage only has a DC component for the differential input case, but for the single-ended input case the input voltage has a DC and an AC component; see Equation 2. The first half of the equation with V_{OCM} in the numerator represents the DC term that is a fixed-value scaled V_{OCM} fed back to the input by the feedback network whereas the second term with V_{Oz} in the numerator is the AC term whose value is a scaled output, V_O , that changes as V_O changes.

$$V_{IN_CM} = \underbrace{\frac{V_{OCM}}{\left(1 + \frac{R_F}{R_G}\right)}}_{\text{DC component}} + \underbrace{\frac{V_{O\pm}}{\left(1 + \frac{R_F}{R_G}\right)}}_{\text{AC component}} = \frac{V_{OCM} \times R_G}{(R_G + R_F)} + \frac{V_{O\pm} \times R_G}{(R_G + R_F)}$$

where

- V_{IN_CM} = Common-mode voltage and is equal to V_{IN+} and V_{IN-} because of the amplifier input virtual short property (2)

Why is Equation 2 important in our attenuator amplifier application? Assuming the V_O peak is fixed by the maximum voltage allowed at the ADC input, depending on the single-ended peak-to-peak input voltage, R_G must be higher than R_F by the same factor by which the input signal needs to be attenuated. Hence, with a larger R_G in the numerator, a larger portion of the V_O voltage is fed to the input, resulting in a higher V_{IN_CM} peak voltage. If the input peak voltage is very high or the circuit has a high attenuation factor, we may start violating the input common-mode range, especially on the high side. FDAs often have a common-mode input range all the way to the negative supply but not as much headroom from the positive supply.

2.2 Circuit Examples

Let's consider an example with the ADS8900B ADC and a V_{REF} of 5 V to see how a high-voltage FDA such as the THS4561 (12.6-V max supply) can be advantageous over the THS4551 (5-V max supply) considering these devices have similar V_{IN_CM} headroom specifications. For a 36- V_{PP} single-ended input centered around a 0-V common-mode voltage, the FDA must be configured for an attenuation of $5 V_P / 18 V_P$ or $10 V_{PP} / 36 V_{PP} = 0.278 V/V$. Assuming $R_F = 1 k\Omega$, R_G is approximately 3.61 k Ω . Setting $V_{OCM} = V_{REF} / 2 = 2.5 V$ and with each FDA output swinging $\pm 2.5 V$ about V_{OCM} , substituting the values in Equation 2, we can derive the V_{IN_CM} signal. This calculation is shown in Equation 3.

$$V_{IN_CM} = \frac{2.5 V}{\left(1 + \frac{1 k\Omega}{3.61 k\Omega}\right)} + \frac{\pm 2.5 V}{\left(1 + \frac{1 k\Omega}{3.61 k\Omega}\right)} = 1.958 V_{DC} \pm 1.958 V \quad (3)$$

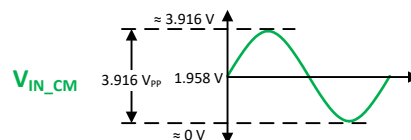

Figure 5. V_{IN_CM} Waveform Based On Equation

Table 1 lists the power supply and common-mode input range comparison for the THS4561 and THS4551. The absolute maximum supply of the THS4551 is 5.5 V but good practice is to limit the operating supply to approximately 90% of the absolute maximum rating for design margin reasons. Using a 5-V operating supply, the maximum common-mode high input allowed is 3.9 V typical and 3.8 V specified minimum. It is then obvious that THS4551 will run into V_{IN_CM} headroom issues. However, in the case of the THS4561, which is a 12.6-V device, we can use a higher supply voltage, which then allows for a higher V_{IN_CM} voltage and the V_{IN_CM} calculated in Equation 3 is now within the allowable range of the device.

Table 1. THS4561 versus THS4551 Power-Supply and Common-Mode Input Range

SPECIFICATION ($T_A = 25^\circ\text{C}$)	THS4561			THS4551			UNIT
	MIN	TYP	MAX	MIN	TYP	MAX	
Abs max supply			13.5			5.5	V
Power-supply range	2.85	10	12.6	2.7	5	5.4	V
Common-mode input, low		$V_{S-} - 0.1$	V_{S-}		$V_{S-} - 0.2$	$V_{S-} - 0.1$	V
Common-mode input, high	$V_{S+} - 1.2$	$V_{S+} - 1.1$		$V_{S+} - 1.2$	$V_{S+} - 1.1$		V

For the signal chains of [Figure 3](#) and [Figure 4](#) that use the OPA2810 and OPA192, respectively, in front of the FDA stage, [Table 2](#) shows the attenuation needed in the FDA stage based on the input signal and the 5-V maximum allowed ADC input, and the common-mode input swing the FDA must support. V_{REF} is assumed to be 5 V and hence V_{OCM} is set at 2.5 V. The THS4561 supports the full output swing of either the OPA2810 or OPA192 if used with greater than 5-V supplies and the THS4551 with 5-V supplies supports the full swing of the OPA2810 with very little margin but struggles to support the full swing of the OPA192.

Table 2. Attenuation and $V_{IN,CM}$ Results for Configurations in Figure 3 and Figure 4

HIGH-Z BUFFER	INPUT SIGNAL SWING	ATTENUATION (R_F / R_G)	$V_{IN,CM}$	$V_{IN,CM}$ SWING
OPA2810	-11.5 V to +11.5 V	5 V / 11.5 V to 0.44 V	1.96 VDC \pm 1.74 V	0.22 to 3.7 V
OPA192	-17.5 V to +17.5 V	5 V / 17.5 V = 0.29 V/V	1.96 VDC \pm 1.94 V	0.02 to 3.9 V

2.3 Amplifier Output Limitations

This is a good lead into the second part of the discussion. While evaluating the $V_{IN,CM}$ limitation of the THS4551, we assumed that the THS4551 output can swing all the way to 5 V on a 5-V supply. Herein lies the other limitation of a 5-V device compared to a 12-V device such as the THS4561. Both the THS4551 and THS4561 can typically swing to within 200 mV of each supply and specified to swing within 230 mV and 350 mV of the supplies, respectively. Which means that with a 0-V to 5-V supply, the THS4551 and THS4561 are typically limited to a $9.2\text{-}V_{PP}$ differential output that is lower than the $10\text{-}V_{PP}$ differential input that the ADC allows with a 5-V V_{REF} . The SNR of the ADC and subsequently that of the signal chain generally suffers when a V_{REF} lower than the maximum allowed by the ADC must be selected to accommodate the limited output swing of the ADC driver.

The differential output range of the THS4551 and THS4561 can be theoretically increased to approximately $9.5\text{-}V_{PP}$ by using a 0.23-V negative bias generator such as the LM7705. However, to truly realize a $10\text{-}V_{PP}$ differential output from the ADC driver for an ADC using a 5-V V_{REF} , a high-voltage device such as the THS4561 using higher than 5.5-V supplies is generally the best solution because the output headroom likely reduces even further as the loading increases on the output when driving the charge bucket filter and the ADC input.

3 TINA-TI Simulation

Figure 6 shows the TINA-TI circuit and the simulation results for the THS4561 in an attenuator configuration. The supplies used are -0.5 V to 5.5 V and V_{OCM} is set to 2.5 V . As shown in the simulation results, there is no $V_{IN,CM}$ (V_{IN+} and V_{IN-}) waveform alteration and the outputs can swing all the way to 5 V when the V_{ODIFF} swing is the full $10\text{-}V_{PP}$ differential that is the full swing range allowed by the ADC input.

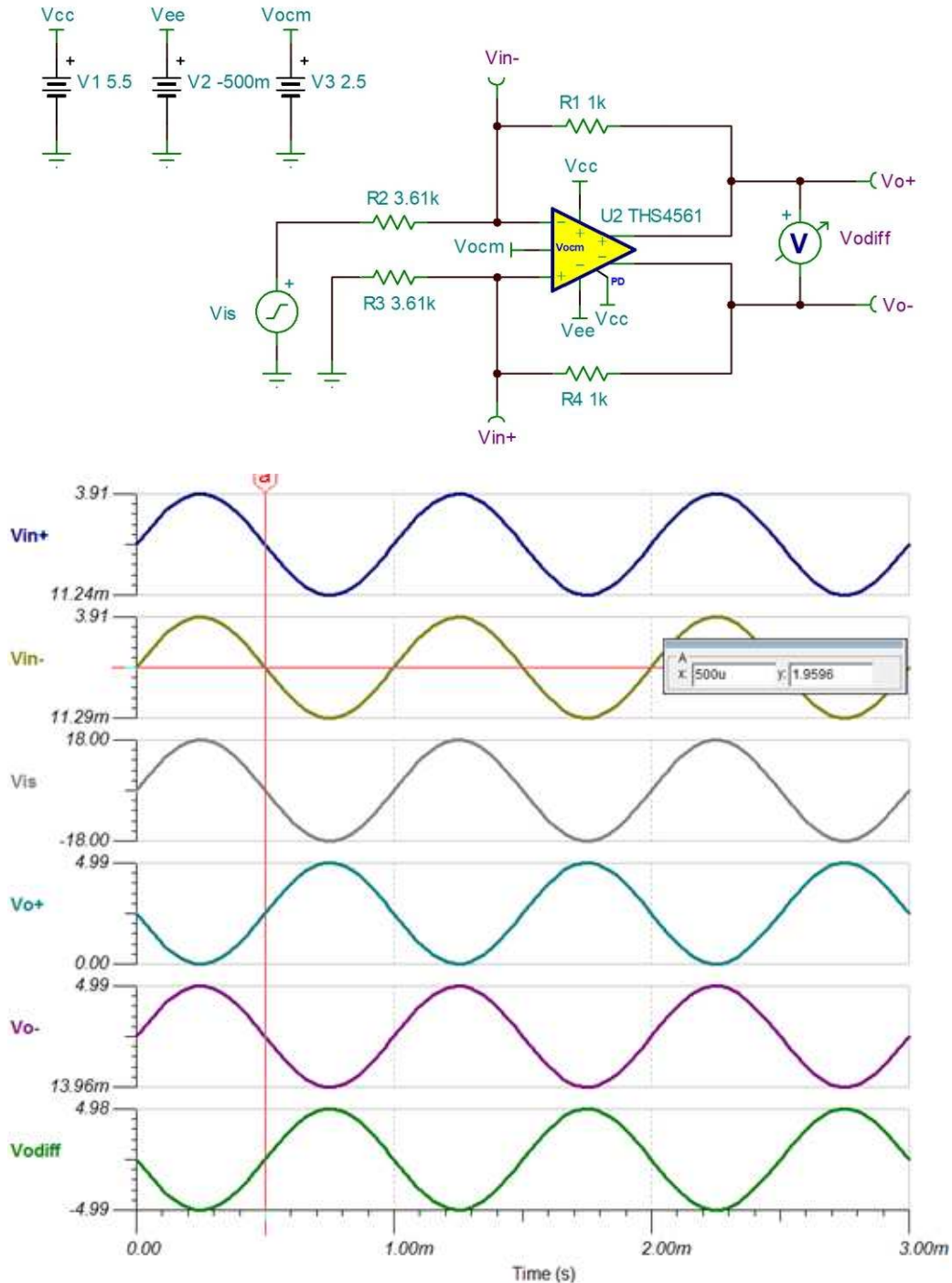

Figure 6. THS4561 TINA Circuit and Simulated Results

The input common-mode limitation is not as much of an issue for the differential input case because the input common-mode is only set by the DC term in [Equation 2](#) and the AC term is zero. Hence, either the THS4551 or THS4561 serve the purpose well. However, the THS4561 does help overcome the output swing limitation because of the high voltage capability of the device.

We have primarily focused on the DC analysis of the attenuator amplifier configuration in this article but something to be wary of for such a configuration is its AC stability and gain peaking. Because of the attenuator configuration, the frequency response can have gain peaking and depending on the amount of peaking, the stability of the circuit may be compromised. In such situations, adding noise shaping capacitors across the inputs and the feedback resistors may be required to reduce the peaking to an acceptable level or stabilize the circuit.

4 Summary

In summary, the 5-V supply of the THS4551 may not be a limiting factor in a number of ADC driver applications because one can design around the common-mode input limitations, and in certain instances, also around the maximum output swing to achieve high SNR considering the low noise of the THS4551. However, for applications that are single-ended and have large input signal swing or where the maximum output swing is required to match the maximum input range of the ADC, a high-voltage FDA such as the THS4561 can be advantageous. Also for applications such as PCM audio DAC output a high-voltage FDA such as the THS4561 is almost always beneficial because this device allows amplification of the DAC output to large signal swings.

5 References

- [TI-Precision Labs FDA Section](#)
- [TIDA-01057 Reference Design Maximizing Signal Dynamic Range for True 10 Vpp Differential Input to 20 bit ADC](#)
- [TINA-TI](#)

IMPORTANT NOTICE FOR TI DESIGN INFORMATION AND RESOURCES

Texas Instruments Incorporated ("TI") technical, application or other design advice, services or information, including, but not limited to, reference designs and materials relating to evaluation modules, (collectively, "TI Resources") are intended to assist designers who are developing applications that incorporate TI products; by downloading, accessing or using any particular TI Resource in any way, you (individually or, if you are acting on behalf of a company, your company) agree to use it solely for this purpose and subject to the terms of this Notice.

TI's provision of TI Resources does not expand or otherwise alter TI's applicable published warranties or warranty disclaimers for TI products, and no additional obligations or liabilities arise from TI providing such TI Resources. TI reserves the right to make corrections, enhancements, improvements and other changes to its TI Resources.

You understand and agree that you remain responsible for using your independent analysis, evaluation and judgment in designing your applications and that you have full and exclusive responsibility to assure the safety of your applications and compliance of your applications (and of all TI products used in or for your applications) with all applicable regulations, laws and other applicable requirements. You represent that, with respect to your applications, you have all the necessary expertise to create and implement safeguards that (1) anticipate dangerous consequences of failures, (2) monitor failures and their consequences, and (3) lessen the likelihood of failures that might cause harm and take appropriate actions. You agree that prior to using or distributing any applications that include TI products, you will thoroughly test such applications and the functionality of such TI products as used in such applications. TI has not conducted any testing other than that specifically described in the published documentation for a particular TI Resource.

You are authorized to use, copy and modify any individual TI Resource only in connection with the development of applications that include the TI product(s) identified in such TI Resource. NO OTHER LICENSE, EXPRESS OR IMPLIED, BY ESTOPPEL OR OTHERWISE TO ANY OTHER TI INTELLECTUAL PROPERTY RIGHT, AND NO LICENSE TO ANY TECHNOLOGY OR INTELLECTUAL PROPERTY RIGHT OF TI OR ANY THIRD PARTY IS GRANTED HEREIN, including but not limited to any patent right, copyright, mask work right, or other intellectual property right relating to any combination, machine, or process in which TI products or services are used. Information regarding or referencing third-party products or services does not constitute a license to use such products or services, or a warranty or endorsement thereof. Use of TI Resources may require a license from a third party under the patents or other intellectual property of the third party, or a license from TI under the patents or other intellectual property of TI.

TI RESOURCES ARE PROVIDED "AS IS" AND WITH ALL FAULTS. TI DISCLAIMS ALL OTHER WARRANTIES OR REPRESENTATIONS, EXPRESS OR IMPLIED, REGARDING TI RESOURCES OR USE THEREOF, INCLUDING BUT NOT LIMITED TO ACCURACY OR COMPLETENESS, TITLE, ANY EPIDEMIC FAILURE WARRANTY AND ANY IMPLIED WARRANTIES OF MERCHANTABILITY, FITNESS FOR A PARTICULAR PURPOSE, AND NON-INFRINGEMENT OF ANY THIRD PARTY INTELLECTUAL PROPERTY RIGHTS.

TI SHALL NOT BE LIABLE FOR AND SHALL NOT DEFEND OR INDEMNIFY YOU AGAINST ANY CLAIM, INCLUDING BUT NOT LIMITED TO ANY INFRINGEMENT CLAIM THAT RELATES TO OR IS BASED ON ANY COMBINATION OF PRODUCTS EVEN IF DESCRIBED IN TI RESOURCES OR OTHERWISE. IN NO EVENT SHALL TI BE LIABLE FOR ANY ACTUAL, DIRECT, SPECIAL, COLLATERAL, INDIRECT, PUNITIVE, INCIDENTAL, CONSEQUENTIAL OR EXEMPLARY DAMAGES IN CONNECTION WITH OR ARISING OUT OF TI RESOURCES OR USE THEREOF, AND REGARDLESS OF WHETHER TI HAS BEEN ADVISED OF THE POSSIBILITY OF SUCH DAMAGES.

You agree to fully indemnify TI and its representatives against any damages, costs, losses, and/or liabilities arising out of your non-compliance with the terms and provisions of this Notice.

This Notice applies to TI Resources. Additional terms apply to the use and purchase of certain types of materials, TI products and services. These include; without limitation, TI's standard terms for semiconductor products (<http://www.ti.com/sc/docs/stdterms.htm>), [evaluation modules](#), and [samples](http://www.ti.com/sc/docs/sampterm.htm) (<http://www.ti.com/sc/docs/sampterm.htm>).

Mailing Address: Texas Instruments, Post Office Box 655303, Dallas, Texas 75265
Copyright © 2018, Texas Instruments Incorporated