

AM263x Sitara™ Microcontrollers ***Texas Instruments Families of Products***

Technical Reference Manual



Literature Number: SPRUJ17A
MARCH 2022 – REVISED AUGUST 2022

Table of Contents



Read This First	7
About This Manual.....	7
Glossary.....	7
Related Documentation From Texas Instruments.....	7
Support Resources.....	7
Release History.....	7
Export Control Notice.....	8
1 Introduction	9
1.1 Overview.....	10
1.2 Device Block Diagram.....	11
1.3 Module Allocation and Instances.....	13
1.4 Device Modules.....	14
1.4.1 Arm Cortex-R5F Processor (R5FSS).....	14
1.4.2 Programmable Real-Time Unit and Industrial Communication Subsystem (PRU_ICSSM).....	15
1.4.3 Hardware Security Module (HSM).....	16
1.4.4 Real-time Control Subsystem (CONTROLSS).....	16
1.4.5 Spinlock (SPINLOCK).....	17
1.4.6 Enhanced Data Movement Architecture (EDMA).....	17
1.4.7 General Purpose Input/Output Interface (GPIO).....	17
1.4.8 Inter-Integrated Circuit Interface (I2C).....	17
1.4.9 Serial Peripheral Interface (SPI).....	17
1.4.10 Universal Asynchronous Receiver/Transmitter (UART).....	18
1.4.11 3-port Gigabit Ethernet Switch (CPSW3G).....	18
1.4.12 Quad Serial Peripheral Interface (QSPI).....	18
1.4.13 General Purpose Memory Controller (GPMC).....	19
1.4.14 Error Location Module (ELM).....	19
1.4.15 Multi-Media Card/Secure Digital Interface (MMCSD).....	19
1.4.16 Controller Area Network (MCAN).....	20
1.4.17 Local Interconnect Network (LIN).....	20
1.4.18 Timers.....	20
1.4.19 Internal Diagnostics Modules.....	20
2 Memory Map	23
2.1 Device Memory Map.....	24
3 System Interconnect	33
3.1 System Interconnect Overview.....	34
3.2 CORE VBUSM Interconnect.....	35
3.3 CORE VBUSP Interconnect.....	37
3.4 PERI VBUSP Interconnect.....	40
3.5 INFRA0 VBUSP interconnect.....	43
3.6 INFRA1 VBUSP Interconnect.....	43
3.7 CONTROLSS interconnect.....	44
3.8 Memory Protection Units (MPU).....	47
3.8.1 MPU Overview.....	47
3.8.2 MPU Functional Description.....	48
3.8.3 MPU Memory Regions.....	52
3.8.4 Initiator IDs.....	53
3.8.5 PrivIDs.....	54
4 Module Integration	55
4.1 ADC Integration.....	56
4.2 DAC Integration.....	57

4.3 ECAP Integration.....	58
4.4 EPWM Integration.....	60
4.5 EQEP Integration.....	62
4.6 FSI Integration.....	63
4.7 SDFM Integration.....	64
4.8 SOC_TIMESYNC_XBAR0 Integration.....	66
4.9 SOC_TIMESYNC_XBAR1 Integration.....	68
GPIO Integration.....	71
4.10 I2C Integration.....	75
4.11 SPI Integration.....	78
4.12 UART Integration.....	84
4.13 CPSW3G Integration.....	90
4.14 MMCSDB Integration.....	93
4.15 QSPI Integration (AM263x).....	96
4.16 MCAN Integration.....	98
4.17 RTI Integration.....	113
4.18 WWDT Integration.....	119
4.19 DCC Integration.....	123
4.20 ESM Integration.....	128
4.21 ECC Aggregator Integration.....	130
4.22 MCRC Integration.....	132
5 Initialization.....	135
5.1 Initialization Overview.....	136
5.1.1 ROM Code Overview.....	136
5.1.2 Bootloader Modes.....	137
5.1.3 Terminology.....	137
5.2 Boot Process.....	139
5.2.1 Public ROM Code Architecture.....	139
5.2.2 HSM ROM Description.....	140
5.3 Boot Mode Pins.....	141
5.3.1 BOOTMODE Pin Mapping.....	141
5.4 Boot Modes.....	142
5.4.1 QSPI Boot.....	142
5.4.2 UART Boot.....	145
5.4.3 DevBoot/NoBoot.....	147
5.5 PLL Configuration.....	148
5.6 Boot Image Format.....	149
5.6.1 Overall Structure.....	149
5.6.2 X.509 Certificate.....	149
5.6.3 Organizational Identifier (OID).....	149
5.6.4 Generating X.509 Certificates.....	151
5.7 Boot Memory Maps.....	154
5.7.1 Memory Layout/MPU.....	154
5.7.2 Global Memory Addresses Used by ROM Code.....	155
6 Device Configuration.....	157
6.1 Control Module (CTRLMMR).....	158
6.1.1 Control Overview.....	159
6.2 Power.....	180
6.2.1 Power Management Overview.....	181
6.2.2 Power System Modules.....	181
6.2.3 Power Control Modules.....	189
6.2.4 Device Power States.....	190
6.3 Reset.....	192
6.3.1 Overview.....	193
6.3.2 Reset Sources.....	196
6.3.3 Reset Status.....	196
6.3.4 Reset Controls.....	198
6.3.5 Reset Details.....	199
6.4 Clocking.....	203
6.4.1 Overview.....	204
6.4.2 Clock IO.....	213

6.4.3 IP Clocking.....	215
6.4.4 Limp Mode.....	237
6.4.5 Clocking Registers.....	238
7 Processors and Accelerators.....	239
7.1 Arm Cortex R5F Subsystem (R5FSS).....	239
7.1.1 R5FSS Overview.....	240
7.1.2 R5FSS Integration.....	242
7.1.3 R5FSS Functional Description.....	250
7.2 Programmable Real-Time Unit Subsystem (PRU-ICSS).....	276
7.2.1 PRU-ICSS Overview.....	277
7.2.2 PRU-ICSS Environment.....	280
7.2.3 PRU-ICSS Integration.....	286
7.2.4 PRU-ICSS Top Level Resources Functional Description.....	291
7.2.5 PRU-ICSS PRU Cores.....	297
7.2.6 PRU-ICSS Broadside Accelerators.....	328
7.2.7 PRU-ICSS Local INTC.....	340
7.2.8 PRU-ICSS UART Module.....	346
7.2.9 PRU-ICSS ECAP Module.....	360
7.2.10 PRU-ICSS MII_RT Module.....	361
7.2.11 PRU-ICSS MII MDIO Module.....	384
7.2.12 PRU-ICSS IEP.....	391
7.3 Hardware Security Module (HSM).....	400
7.4 Real-time Control Subsystem (CONTROLSS).....	401
7.4.1 Real-time Control Subsystem (CONTROLSS) Overview.....	401
7.4.2 Analog-to-Digital Converter (ADC).....	402
7.4.3 Comparator Subsystem (CMPSS).....	443
7.4.4 Buffered Digital-to-Analog Converter (DAC).....	455
7.4.5 Enhanced Pulse Width Modulator (ePWM).....	460
7.4.6 Enhanced Capture (eCAP).....	577
7.4.7 Enhanced Quadrature Encoder Pulse (eQEP).....	607
7.4.8 Fast Serial Interface (FSI).....	634
7.4.9 Sigma Delta Filter Module (SDFM).....	671
7.4.10 Crossbar (XBAR).....	699
8 Interprocessor Communication.....	725
8.1 Mailbox.....	726
8.1.1 Mailbox.....	727
8.1.2 Mailbox Message Scheme.....	727
8.1.3 Mailbox Message Example.....	728
8.1.4 Mailbox Registers.....	728
8.2 Spinlock.....	730
8.2.1 Spinlock Overview.....	731
8.2.2 Spinlock Integration.....	732
8.2.3 Spinlock Functional Description.....	733
8.2.4 Spinlock Programming Guide.....	735
9 Memory Controllers.....	737
9.1 Memory Controllers Overview.....	738
10 Interrupts.....	739
10.1 Interrupt Architecture.....	740
10.2 Interrupt Controllers.....	740
10.2.1 Vectored Interrupt Manager (VIM).....	740
10.2.2 Other Interrupt Controllers.....	747
10.3 Interrupt Routers.....	748
10.3.1 INTRTR Overview.....	748
10.3.2 INTRTR Integration.....	749
10.4 Interrupt Sources.....	764
10.4.1 R5FSS0_CORE0 Interrupt Map.....	765
10.4.2 R5FSS0_CORE1 Interrupt Map.....	773
10.4.3 R5FSS1_CORE0 Interrupt Map.....	781
10.4.4 R5FSS1_CORE1 Interrupt Map.....	786
10.4.5 PRU_ICSSM0 Interrupt Map.....	793
10.4.6 ESM0 Interrupt Map.....	795

11 Data Movement Architecture	799
11.1 Data Movement Architecture Overview.....	801
11.1.1 Overview.....	802
11.1.2 Definition of Terms.....	802
11.2 Enhanced Direct Memory Access (EDMA).....	804
11.2.1 EDMA Module Overview.....	805
11.2.2 EDMA Integration.....	806
11.2.3 EDMA Controller Functional Description.....	809
11.2.4 EDMA Transfer Examples.....	858
11.2.5 EDMA Debug Checklist and Programming Tips.....	865
11.2.6 EDMA Event Map.....	867
12 Time Sync	869
12.1 Time Sync Architecture.....	870
12.1.1 Time Sync Architecture Overview.....	870
12.2 Time Sync Routers.....	872
12.2.1 Time Sync Routers Overview.....	872
12.2.2 Time Sync Routers Integration.....	872
12.2.3 Time Sync Routers Registers.....	877
12.3 Time Sync and Compare Events.....	878
12.3.1 TimeSync Event Sources.....	878
13 Peripherals	881
13.1 General Connectivity Peripherals.....	882
13.1.1 General-Purpose Interface (GPIO).....	883
13.1.2 Inter-Integrated Circuit (I2C) Interface.....	899
13.1.3 Multichannel Serial Peripheral Interface (MCSPI).....	927
13.1.4 Universal Asynchronous Receiver/Transmitter (UART).....	978
13.2 High-speed Serial Interfaces.....	1047
13.2.1 Gigabit Ethernet Switch (CPSW3G).....	1048
13.3 Memory Interfaces.....	1157
13.3.1 General-Purpose Memory Controller (GPMC).....	1158
13.3.2 Error Location Module (ELM).....	1268
13.3.3 Multimedia Card (MMC).....	1280
13.3.4 Quad Serial Peripheral Interface (QSPI).....	1326
13.4 Industrial and Control Interfaces.....	1340
13.4.1 Modular Controller Area Network (MCAN).....	1341
13.4.2 Local Interconnect Network (LIN).....	1388
13.5 Timer Modules.....	1438
13.5.1 Real Time Interrupts/Windowed Watchdog Timer (RTI/WWDT).....	1438
13.6 Internal Diagnostics Modules.....	1462
13.6.1 Dual Clock Comparator (DCC).....	1463
13.6.2 ECC Aggregator.....	1474
13.6.3 Error Signaling Module (ESM).....	1482
13.6.4 Memory Cyclic Redundancy Check (MCRC) Controller.....	1498
13.6.5 Self-Test Controller (STC).....	1512
14 On-Chip Debug	1525
14.1 On-Chip Debug.....	1526
14.1.1 On-Chip Debug Overview.....	1526
14.1.2 On-Chip Debug Features.....	1526
14.1.3 On-Chip Debug Functional Description.....	1527
15 Revision History	1537



Note

The content of this document is EARLY PRELIMINARY INFORMATION, for use before and during early silicon validation and characterization efforts, and is likely to be modified before official production release of the of the TRM.

References between chapters are intentionally undefined for preliminary book assembly purposes.

About This Manual

This Technical Reference Manual (TRM) details the integration, the environment, the functional description, and the programming models for each peripheral and subsystem in the device.

Glossary

[TI Glossary](#) This glossary lists and explains terms, acronyms, and definitions.

Related Documentation From Texas Instruments

For a complete listing of related documentation and development-support tools for the device, visit the Texas Instruments website at www.ti.com.

Below are some direct links to additional documentation:

- [AM263x Data sheet](#)
- [AM263x Errata Silicon Revision 1.1](#)
- [AM263x Technical Reference Manual](#)
- [AM263x Register Addendum](#)
- [AM263x Hardware Design Guidelines](#)
- [MCU-PLUS-SDK-AM263x](#)

Support Resources

[TI E2E™ support forums](#) are an engineer's go-to source for fast, verified answers and design help — straight from the experts. Search existing answers or ask your own question to get the quick design help you need.

Linked content is provided "AS IS" by the respective contributors. They do not constitute TI specifications and do not necessarily reflect TI's views; see TI's [Terms of Use](#).

A Register Addendum PDF has been created in order to make the Technical Reference Manual a more effective and size-efficient collateral document, The AM263x Register Addendum can be downloaded at .

Release History

The following table summarizes the AM263x Silicon Revision 1.0A Technical Reference Manual versions.

Version	Literature Number	Date	Notes
*1	SPRUJ17*1	March 2022	See

Trademarks

TI E2E™ is a trademark of Texas Instruments.

PROFINET™ is a trademark of PROFIBUS Nutzerorganisation e.V.

EtherNet/IP™ is a trademark of ODVA, Inc.

EtherCAT® is a registered trademark of Beckhoff Automation GmbH.

PROFIBUS® is a registered trademark of PROFIBUS Nutzerorganisation e.V.

ARM® and Cortex® are registered trademarks of ARM Limited.

Arm® is a registered trademark of Arm Limited (or its subsidiaries) in the US and/or elsewhere.

All trademarks are the property of their respective owners.

Export Control Notice

Recipient agrees to not knowingly export or re-export, directly or indirectly, any product or technical data (as defined by the U.S., EU, and other Export Administration Regulations) including software, or any controlled product restricted by other applicable national regulations, received from disclosing party under nondisclosure obligations (if any), or any direct product of such technology, to any destination to which such export or re-export is restricted or prohibited by U.S. or other applicable laws, without obtaining prior authorization from U.S. Department of Commerce and other competent Government authorities to the extent required by those laws.



This chapter introduces the features, subsystems, and architecture of the AM263x Sitara MCU Processor Platform high-performance System-on-Chip (SoC).

Note

This document describes the superset architecture, processors, and peripherals of the AM263x Family of SoCs, which are part of the Sitara MCU Processors Multicore SoC architecture platform. Not all features are available on each family of devices. The superset AM263x device will be available for preproduction software development. Software should constrain the features used to match the intended production device. For more information on the specific modules and features available on a particular device, refer to the device comparison table in the corresponding device-specific Datasheet.

The AM263x Sitara Processor Platform is hereinafter commonly referred to as *AM263x, platform, device, chip, or SoC*.

1.1 Overview	10
1.2 Device Block Diagram	11
1.3 Module Allocation and Instances	13
1.4 Device Modules	14

1.1 Overview

The AM263x Sitara Arm Microcontrollers are built to meet the complex real-time processing and control needs of next generation industrial and automotive embedded projects. AM263x uniquely combines advanced compute with industry leading real-time control to meet the growing performance needs of applications such as HEV/EV (traction inverters, Onboard Chargers, and DC-DC Converters), motor drives, solar energy, and energy storage. AM263x combines up to four Cortex-R5F MCUs, a real-time control subsystem, a Hardware Security Module (HSM), and one instance of Sitara's TSN-enabled PRU-ICSS, making AM263x designed for advanced motor control and digital power control applications.

The multiple R5F cores are arranged in cluster with 256KB of shared tightly coupled memory (TCM) along with 2MB of shared SRAM. The multiple Arm® cores can be optionally programmed to run in lock-step option for different functional safety configurations. Extensive ECC is included on on-chip memory, peripherals, and interconnect for enhanced reliability. Cryptographic acceleration and secure boot are also available on AM263x devices in addition to granular firewalls managed by the HSM for developers to design the most secure systems.

The Real-Time Control Subsystem (CONTROLSS) is a revolutionary subsystem integrated into the device. It contains multiple digital and analog control peripherals including: ADC, CMPSS, EPWM, ECAP, and EQEP, among others to enable efficient execution of critical sense/process/actuate real-time signal chain control loops. The integrated crossbar (XBAR) infrastructure enables flexible configuration and routing of external signals to internal ports and internal signals to external pins.

The PRU-ICSS in AM263x provides the flexible industrial communications capability necessary to run TSN, EtherCAT, PROFINET, EtherNet/IP, or for standard Ethernet connectivity or custom I/O interfacing. The PRU also enables additional interfaces in the SoC including sigma delta decimation filters and absolute encoder interfaces. Additional standard ethernet ports are also provided with the CPSW interface.

TI provides a complete set of microcontroller software and development tools for the AM263x family of microcontrollers in addition to multiple pin-to-pin compatible devices for scalability and ease of use.

1.2 Device Block Diagram

Device Top-level Block Diagram

Figure 1-1 shows the device top-level block diagram.

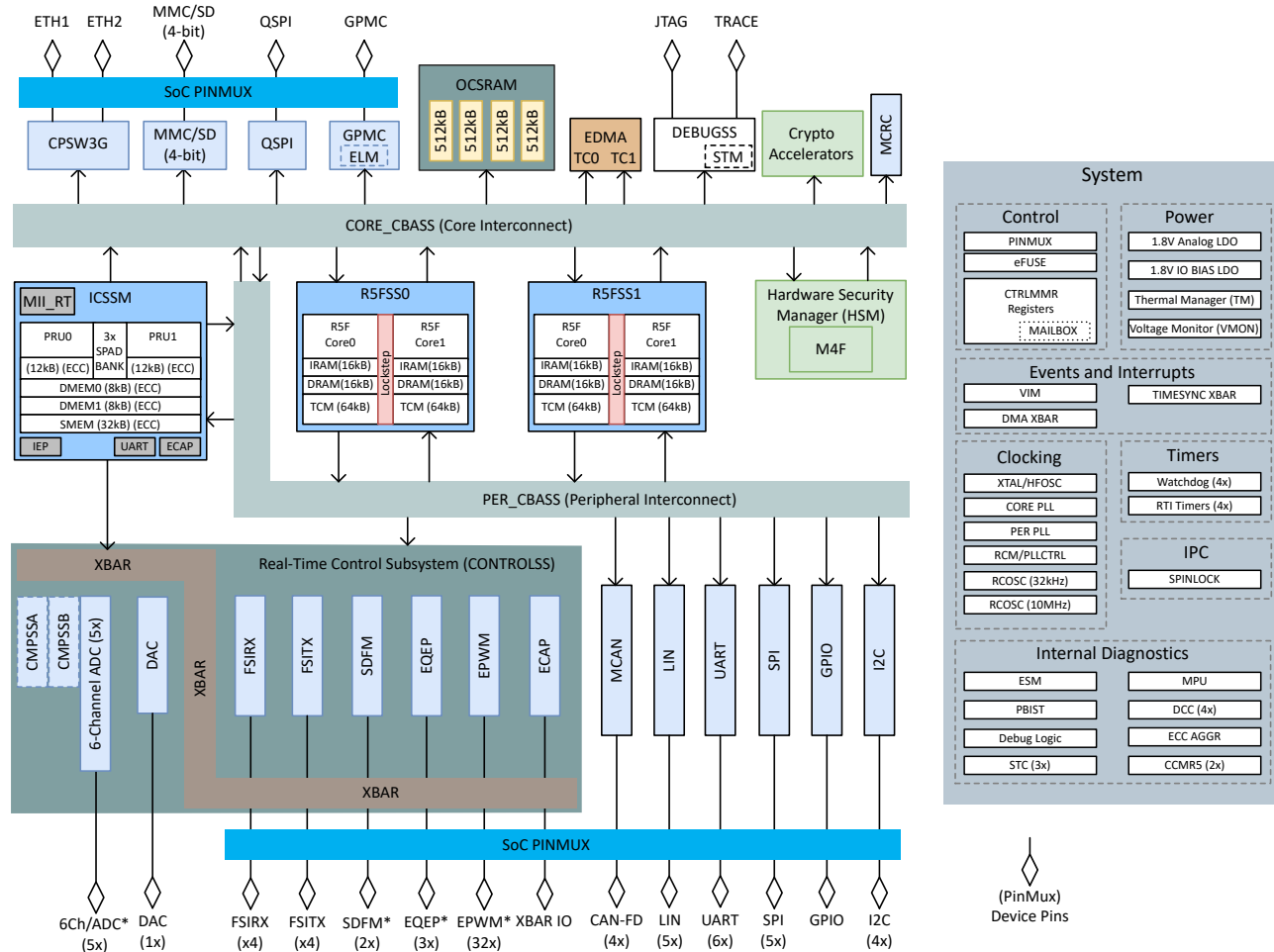

ADVANCE INFORMATION

Note

*Check the device data sheet for # of supported instances.

1.3 Module Allocation and Instances

Module Abbreviation	Module Full Name	Device Instances
SOC Modules		
R5FSS	Dual Core Arm Cortex-R5F Subsystem	2
PRU-ICSSM	Industrial Communication Subsystem with Programmable Real-time Unit	1
HSM	Hardware Security Manager (M4F-based Subsystem)	1
SPINLOCK	Interprocessor Communication - SPINLOCK	1
EDMA	Enhanced DMA	1x/SoC (2x TC + 1x CC)
General Connectivity Peripherals		
GPIO	General Purpose Input/Output	138x
I2C	Inter-Integrated Circuit	4
SPI	Serial Peripheral Interface	5
UART	Universal Asynchronous Receiver/Transmitter	6
High-speed Serial Interfaces		
CPSW3G	2x External Port Gigabit Ethernet Switch	1
Industrial and Control Interfaces		
MCAN	Controller Area Network Interface	4
LIN	Local Interconnect Network	5
Memory Interfaces		
QSPI	Quad Serial Peripheral Interface	1
GPMC	General Purpose Memory Controller	1
ELM	Error Location Module	1
MMCSD	Multi-Media Card/Secure Digital (4-bit) Interface	1
Timer Modules		
RTI/WWDT	Real Time Interrupt/Windowed WatchDog Timer	4
RTI	Real Time Interrupt Timer	4
Internal Diagnostics Modules		
DCC	Dual Clock Comparator	4
ESM	Error Signaling Module	1
MCRC	Memory Cyclic Redundancy Check Controller	1
Crypto Accelerator	Cryptographic HW Accelerator	1
ECC	OCSRAM ECC Aggregator	1x-SoC 4x-R5FSS 1x-ICSSM 4x-MCAN 1x-CPSW3G
Real-time Control Subsystem (CONTROLSS)		
Analog Control Peripherals		
ADC	Analog to Digital Converter	5 (6 Channels per ADC)
CMPSSA	Comparator Subsystem A	10 (2x/ADC)

Module Abbreviation	Module Full Name	Device Instances
CMPSSB	Comparator Subsystem B	10 (2x/ADC)
DAC	Buffered Digital to Analog Converter	1
Digital Control Peripherals		
EPWM	Enhanced Pulse Width Modulation Module	32
EQEP	Enhanced Quadrature Encoder Pulse Module	3
ECAP	Enhanced Capture Module	10
SDFM	Sigma-Delta Filter Module	2
FSI	Fast Serial Interface (RX/TX)	4x RX 4x TX
Crossbar Modules		
INPUTXBAR	Flexible Signal Multiplex Input Crossbar	1
OUTPUTXBAR	Flexible Signal Multiplex Output Crossbar	1
DMAXBAR	EDMA Data Movement Architecture Crossbar	1
PWMXBAR	PWM Signal Crossbar	1
PWMSYNCOUXTBAR	PWM Sync Output Crossbar	1

1.4 Device Modules

This section describes the modules integrated in the device.

1.4.1 Arm Cortex-R5F Processor (R5FSS)

The ARM Dual-Core Cortex-R5F processor subsystem (R5FSS) supports the following main features:

- Armv7-R architecture
- Supported modes of operation (boot-time configurable):
 - Dual Core mode: two independent free-operating cores (Asymmetric Multi-Processing, no coherence)
 - Lockstep mode: one free-operating core and a lockstep core for safety-enabled applications
 - There is a two clock cycle delay between CORE0 and CORE1 in lockstep mode. Any errors are routed to the Error Signal Module (ESM) which in turn is routed as an interrupt to the CPU. The ESM is also available as an I/O pin which can be used for external monitoring. See the *Error Signal Module* chapter for more details.
- R5FSS Memory System
 - 16KB Instruction Cache
 - 4x4KB ways
 - SECEDED ECC protected per 64 bits
 - 16KB Data Cache
 - 4x4KB ways
 - SECEDED ECC protected per 32 bits
 - 64KB tightly-coupled memory (TCM) per CPU
 - SECEDED ECC protected per 32 bits
 - TCM hard error cache Implemented in CPU
 - Readable/writable from system
 - Configurable reset initialization values
 - 32KB TCMA (ATCM)
 - 16KB TCMB0 (B0TCM)
 - 16KB TCMB1 (B1TCM)
- Full-precision Floating Point (VFPv3)
- 16-region Memory Protection Unit (MPU)
- 8 breakpoints, 8 watch points

- CoreSight Debug Access Port (DAP)
- CoreSight ETM-R5 interface (CTI, ETM)
- Performance Monitoring Unit (PMU)
-
- Integrated Vectored Interrupt Manager (VIM) per core with 256 Interrupt Inputs each
 - Programmable interrupt priority (4-bit)
 - Programmable interrupt enable mask
 - Software-generated interrupts
 - Synchronous clock domain crossing on all core interfaces

Note

The operating cores can be configured to use the full TCM memory space available to both cores.

In Dual Core mode, CORE0 and CORE1 have 64KB of TCM:

- 32KB TCMA
- 16KB TCMB0 + 16KB TCMB1

In Lockstep mode, CORE0 has 128KB of TCM :

- 64KB TCMA
 - 64KB TCMB (32KB TCMB0 + 32KB TCMB1)
-

Note

These details describe a superset of the R5FSS memory configuration. For additional details on device memory availability, please refer to the device-specific Datasheet.

1.4.2 Programmable Real-Time Unit and Industrial Communication Subsystem (PRU_ICSSM)

One instance of the Programmable Real-Time Unit and Industrial Communication Subsystem (PRU_ICSSM) allows implementation of various high-performance industrial control algorithms and industrial interface standards such as PROFINET™ and EtherCAT®.

The PRU_ICSSM subsystem supports the following main features, among others:

- One Programmable Real-time Unit Subsystems (PRUSS):
 - 2x PRU (PRU0/PRU1)
- 32KB shared general purpose RAM with ECC
- Two 8KB data memories with ECC
- Two 10/100/1000 Ethernet Ports
- One Industrial Ethernet Peripherals (IEP) to manage/generate Industrial Ethernet functions
- One 16550-compatible UART module, with a dedicated 192 MHz to support 12 Mbps PROFIBUS
- One industrial Ethernet 64-bit timers, each with 10 capture and 16 compare events, along with slow and fast compensation
- One Enhanced Capture (ECAP) module
- One Pulse Width Modulation (PWM) module with flexible real time safety options and output behavior
 - Supports up to 4 sets of 3-phased motor control, with 12 primary and 12 complimentary programmable PWM outputs
 - Up to 9 safety events with optional external trip I/O per PWM set with hardware glitch filter
- One interrupt controller (INTC) with 160 input events supported – 96 external, 64 internal
- ECC support for all internal memories
- Flexible clock gating support for power management

Among the interfaces supported by the PRU_ICSSG are real-time industrial protocols used in master and slave mode, such as:

- EtherCAT®
- PROFINET™
- EtherNet/IP™

- PROFIBUS®

Note

See device-specific Datasheet for more details related to industrial protocol support.

1.4.3 Hardware Security Module (HSM)

One Hardware Security Module (HSM) to facilitate the device security-related functionality:

- Arm Cortex M4F Core (200 MHz)
- 1x Real-time Interrupt (RTI) module
- 1x RTI/WWDT module used as watchdog (WD mode)
- 2x Timers
 - 32-bit up counter
 - Cascading mode support for 2x 64 bit counters
- HSM Mailbox for Messaging between HSM and host processors.
- Designated HSM DMA to fetch and store the data for cryptography services.
- Hardware Security Accelerators (200MHz)
 - Symmetric Encryption/Decryption
 - AES: 128, 192 and 256-bits key
 - Cipher modes ECB, CTR, CBC, GCM
 - CBC-MAC, CMAC based on AES
 - Asymmetric Cryptography
 - High-performance PKA (public key engine) for large vector math/modulus operation
 - RSA2048, RSA3092, RSA4096
 - ECC Secp/NIST Curves: Curve25519, X25519, secP256r1, secP256k1, secP384r1, secP384k1, Brain pool, and others.
 - Hashing HMAC
 - SHA2 – 256, 384 and 512-bit support
 - HMAC-SHA256, HMAC-SHA512 – Keyed Hashing
 - Random Number Generator
 - DRBG with Pseudo and True Random number generation support
 - Capability to seed the PRNG with TRNG seed

1.4.4 Real-time Control Subsystem (CONTROLSS)

The integrated real-time Control Subsystem (CONTROLSS) enables closed loop control systems with flexible interconnection between data acquisition, actuator modules, and other control signal resources. The CONTROLSS module consists of the following control peripherals:

Analog Control Peripherals

- 5x Analog to Digital Converter (ADC) modules
 - 12-bit resolution with 4MSPS sample rate
 - Programmable 6x single-ended or 3x differential channels
 - 3.2V full scale voltage range with 1.8V reference (32/18 internal input scaling)
 - Support for internal or external 1.8V ADC VREF reference voltage (2% internal reference accuracy error)
 - Two common external calibration pins
 - 4x Post-processing blocks per ADC
 - Multiple ADC trigger sources including CPU timers, GPIO/Input XBAR, and EPWM SOCa/SOCb signals.
- 1x Buffered Digital to Analog (DAC) module
 - 12-bit resolution
- 10x Comparator Subsystem A (CMPSSA)
 - 2 comparators + 2 DACs
 - Window comparison on one input OR
 - Compare two inputs OR
 - Single threshold compare of single input
- 10x Comparator Subsystem B (CMPSSB)

- 2 comparators + 2 DACs
- Window comparison on one input OR
- Single threshold compare of single input

Digital Control Peripherals

- 32x Enhanced Pulse-width Modulation (EPWM) modules
- 10x Enhanced Capture (ECAP) modules
- 2x Sigma-Delta Filter (SDFM) modules
- 3x Enhanced Quadrature Encoder Pulse (EQEP) modules
- 4x Fast Serial Interface Transmitter (FSITX) modules
- 4x Fast Serial Interface Receiver (FSIRX) modules

1.4.5 Spinlock (SPINLOCK)

One Spinlock module with (256 hardware semaphores) for synchronizing the processes running on multiple cores in the device.

1.4.6 Enhanced Data Movement Architecture (EDMA)

One Enhanced Data Movement Architecture (EDMA) module can be used for efficient transfer of data and support between software, firmware, and hardware in all combinations. The EDMA consists of a single Channel Controller (TPCC) and two Transfer Controllers (TPTC) to enable various data movement requirements.

1.4.7 General Purpose Input/Output Interface (GPIO)

Four General Purpose Input/Output (GPIO) modules, each dedicated to a specific R5FSS core. These provide dedicated general-purpose pins that can be configured as either inputs or outputs. The GPIO module main features include:

- Support of 9 banks x 16 interrupt-capable GPIO pins
- Interrupts can be triggered by rising and/or falling edge, specified for each GPIO pin
- Set/clear functionality per individual GPIO pin
- CPUs can control the GPIOs on a per pin granularity
 - Each processor core has a separate module for controlling GPO pins and observing GPI pins
 - IOMUX CTRLMMR register-based 4:1 multiplexer to individually assign GPO pin control to a specific processor core
 - GPI pins are observable by all processor cores
- Support for GPI signal conditioning chain
 - Invert/Non-invert
 - Signal Qualification
 - Asynchronous input
 - Synchronise to SYSCLK
 - Qualification using sampling window
- Software-based tristate control to emulate open-drain IO mode

1.4.8 Inter-Integrated Circuit Interface (I2C)

Four instances of the multi-controller Inter-Integrated Circuit (I2C) interface module, each with the following main features:

- 1x Instances with open-drain voltage buffers in compliance with the Philips I2C-bus specification version 2.1
- Support of standard mode (up to 100 Kbps) and fast mode (up to 400 Kbps)
- Support of 7-bit and 10-bit device addressing modes
- 8-bit-wide data access
- Support of multi-controller transmitter/peripheral receiver and receiver/peripheral transmitter modes
- Built-in FIFOs with programmable size of 8 to 64 bytes for buffered read or write

1.4.9 Serial Peripheral Interface (SPI)

Five instances of the Serial Peripheral Interface (SPI) module with the following main features:

- Serial clock with programmable frequency, polarity, and phase for each channel

- Wide selection of SPI word lengths, ranging from 4 to 32 bits
- Up to two channels in controller mode, or single channel in receiver mode
- Support for various controller multichannel modes
- Single interrupt line for multiple interrupt source events
- Support of start-bit write command
- Support of start-bit pause and break sequence
- Built-in FIFO available for a single channel

1.4.10 Universal Asynchronous Receiver/Transmitter (UART)

Six instances of the configurable Universal Asynchronous Receiver/Transmitter (UART) interface module with the following main features:

- 16C750-compatible interface
- Support of RS-485 external transceiver auto flow control
- Dual 64-byte FIFOs – one per each received and transmitted data paths
- Programmable and selectable transmit and receive FIFO trigger levels for DMA and interrupt generation
- Programmable sleep mode
- Baud-rate from 300 bits/s up to 3.6864 Mb/s with 48 MHz functional clock
- Auto-baud between 1200 bits/s and 115.2 Kbits/s (only when 48 MHz function clock is used)
- Support of IrDA 1.4 Slow Infrared (SIR), Medium Infrared (MIR), and Fast Infrared (FIR) communications
- Support of Consumer Infrared Remote control mode (CIR) with programmable data encoding

Note

Only one UART instance has support for support full modem control functions. All other UART instances will support only the TX, RX, RTS, and CTS signals.

1.4.11 3-port Gigabit Ethernet Switch (CPSW3G)

One instance of the 3-port Gigabit Ethernet Switch (CPSW3G) subsystem provides Ethernet packet communication for the device. The CPSW3G subsystem provides the following main features:

- Two external Ethernet ports with selectable RGMII, RMII, and MII interfaces and one internal Communications Port Programming Interface (CPPI) port.
- Synchronous 10/100/1000 Mbit operation
- Flexible logical FIFO-based packet buffer structure
- Support of eight priority level Quality Of Service (QOS) - 802.1p
- Support for Audio/Video Bridging (P802.1Qav/D6.0 and 802.1Qaz)
- Support for IEEE 1588 Clock Synchronization (2008 Annex D, Annex E and Annex F)
- Differentiated Services Code Point (DSCP) Priority Mapping (IPv4 and IPv6)
- IPV4/IPV6 UDP/TCP checksum offload
- Priority Based Flow Control (801.1QBB) and Flow Control (802.3x) Support
- Wire rate switching (802.1d)
- Store and Forward Switching
- Non-Blocking switch fabric
- Support of Time Sensitive Network - IEEE P902.3br/D2.0 Interspersing Express Traffic and IEEE 802.1Qbv/D2.2 Enhancements for Scheduled Traffic
- Address Lookup Engine (ALE) with 512 ALE table entries
- EtherStats and 802.3 Stats Remote Network Monitoring (RMON) statistics gathering (per port statistics)
- Maximum frame size of 2020 bytes
- Management Data Input/Output (MDIO) module for PHY Management
- Host port CPPI Streaming Packet Interface
- Emulation support

1.4.12 Quad Serial Peripheral Interface (QSPI)

One instance of the Quad Serial Peripheral Interface (QSPI) with support for the following main features:

- Programmable divider for serial data clock generation
- Six pin interface (CLK, CS_N, DOUT, DIN, QDIN1, QDIN2)

- Programmable data length (No. of bits from 1-32)
- Up to 2 external chip select signals
- Support for 3-, 4- or 6-pin SPI interface
 - 3-pin mode: spi_dout (inout) and spi_din is not used
 - 4-pin mod: spi_dout (inout) and spi_din (in)
 - 6-pin mode: spi_dout (inout), spi_din (in), spi_qdin0 (in), and spi_qdin1 (in)
- Programmable transfer or frame size (No. of words from 1 to 4096)
- Optional interrupt generation on word or frame completion
- Programmable CS_N to DOUT delay from 0 to 3 QSPI interface clocks
- Programmable signal polarities
- Programmable active clock edge

1.4.13 General Purpose Memory Controller (GPMC)

One instance of the General-Purpose Memory Controller (GPMC) module. The GPMC is dedicated to interfacing with external memory devices and has the following main features:

- Support of 8- or 16-bit-wide data path to external memory devices
- Supports up to 4 independent chip-select regions of programmable size and programmable base addresses on 16MB, 32MB, 64MB, or 128MB boundary in a total address space of 128MB
- Support of the following wide range of external memories/devices:
 - Asynchronous or synchronous 8-bit wide memory or device (non-burst device)
 - Asynchronous or synchronous 16-bit wide memory or device
 - 16-bit non-multiplexed NOR flash device
 - 16-bit address and data multiplexed NOR flash device
 - 8-bit and 16-bit NAND flash device
 - 16-bit pseudo-SRAM (pSRAM) device
- Supports various interface protocols when communicating with external memory or external devices:
 - Asynchronous read/write access
 - Asynchronous read page access (4, 8, and 16 Word16)
 - Synchronous read/write access
 - Synchronous read burst access without wrap capability (4, 8, and 16 Word16)
 - Synchronous read burst access with wrap capability (4, 8, and 16 Word16)
- Supports up to 16-bit on-the-fly error code detection using the Bose-Chaudhuri-Hocquenghem (BCH) or Hamming code to improve the reliability of NAND with a minimum effect on software (NAND flash with 512-byte page size or greater)

1.4.14 Error Location Module (ELM)

One instance of the Error Location Module (ELM). The ELM module works in conjunction with the GPMC and has the following main features:

- ECC calculations (up to 16-bit) for NAND support and ability to work in both page-based and continuous modes
 - 4, 8, and 16 bits per 512-byte block error-location, based on BCH algorithms
 - Eight simultaneous processing contexts
 - Page-based and continuous modes
 - Interrupt generation on error-location process completion

1.4.15 Multi-Media Card/Secure Digital Interface (MMCSD)

One Multi-Media Card/Secure Digital (MMCSD) controller module with the following features:

- One controller with 4-bit wide data bus
- Support of MMC 4.3 Host Specification
- Support of SD Host Controller Standard Specification - SDIO 2.00
- Multi-Media card features:
 - 3.3v legacy modes with 1-bit single data rate (0-24MHz clock)
 - 3.3v HS-SDR with 4-bit bus width (0-48MHz Clock)
- SD card support:

- DS mode (1/4-bit, 3.3V): up to 12 MBps (24 MHz clock)
- HS mode (1/4-bit, 3.3V): up to 24 MBps (48 MHz clock)
- Supports Card Detect (SDCD) and Write Protect (SDWP)

1.4.16 Controller Area Network (MCAN)

Four Controller Area Network interfaces (MCAN) with support for classic CAN and CAN FD (CAN with Flexible Data-Rate) specifications. The MCAN module consists of the following main features:

- Conforms with CAN Protocol version 2.0 part A, B and ISO 11898-1:2015
- Full CAN FD (up to 64 data bytes) support
- AUTOSAR and SAE J1939 support
- Loopback mode for self-test
- Up to 32 dedicated transmit buffers and 64 dedicated receive buffers
- Two configurable receive FIFOs, up to 64 elements each
- Configurable transmit FIFO, up to 32 elements
- Configurable transmit queue, up to 32 elements
- Configurable transmit event FIFO, up to 32 elements
- Up to 128 filter elements
- Two interrupt lines with support for maskable interrupts
- Timestamp Counter

1.4.17 Local Interconnect Network (LIN)

Five instances of the configurable Local Interconnect Network (LIN) interface module with the following main features:

- 16C750-compatible
- Compatibility with LIN 1.3, 2.0, and 2.1 protocols
- Enhanced Baud Rate Generated configurable up to 20 kbps
 - 2^{31} programmable transmission rates with 7 fractional bits
- Two external pins: LINRX and LINTX.
- Multi-buffered receive and transmit units
- Automatic wake-up support and bus idle detection
- Support for common Error Detection methods

1.4.18 Timers

Two sets of timer modules are instantiated in the device:

- Four RTI Timer instances, implemented by the Real-time Interrupt function of the RTI/WWDT module.
- Four Windowed Watchdog Timer (WWDT) instances, implemented by the Digital Windowed Watchdog (DWWDT) function of the RTI/WWDT module
- The RTI/WWDT provides timer functionality for operation systems and benchmarking code with the following main features:
 - Two independent 64 bit counter blocks
 - Four configurable compare registers for generating operating system ticks
 - Free running counter 0 can be incremented by either the internal pre-scale counter or by an external event
 - Selectable RTI clock input (derived from any of the available clock sources)
 - Fast enabling/disabling of events

1.4.19 Internal Diagnostics Modules

Instantiated in the device are various internal diagnostics modules which provide on-chip monitoring and diagnostic functions required to achieve certain safety compliance levels:

- Four Dual Clock Comparator (DCC) modules, used to determine the accuracy of a clock signal during the time execution of an application, each having the following main features:
 - Two independent counter blocks count clock pulses from each clock source
 - Each counter block is programmable, however, for proper operation the counters must be programmed with seed values that respect the ratio of the two clock frequencies
 - Configurable time base for error signal

- Error signal generation when one of the clocks is out of spec
- Clock frequency measurement
- One Memory Cyclic Redundancy Check (MCRC) module to enable hardware-based CRC calculations.
- Integrated on-die temperature monitor (+/- 8° C temperature accuracy)
- One instance of Error Signaling Module (ESM) for safety-related events and/or errors aggregation from throughout the device into one location supports the following main features:
 - Up to 1024 level or pulse error event inputs
 - Selectable low and high priority interrupt error pin prioritization of each error event
 - Error signal routed out of device through MCU_ESM error signal
 - Configurable time base for error signal
 - Error forcing capability
 - Internal redundant flops on safety critical fields
- Multiple ECC Aggregator modules supporting ECC mechanism for providing increased system reliability via reduction of memory software errors by allowing single bit errors to be detected and corrected (SEC) and double bit errors to be detected (DED). Applied to different memories in many of the subsystems, each of the ECC aggregators has the following main features:
 - Reduces memory software errors via single error correction (SEC) and double error detection (DED)
 - Provides a mechanism to control and monitor the ECC RAMs in a module or subsystem
 - Supports software readable status of ECC errors (single and double-bit) and associated info such as RAM address and data bit or bits that are in error
 - Aggregates level pending status from the ECC RAMs in two interrupts to the device CPU – interrupt for correctable error (SEC) and interrupt for uncorrectable error (DED)
 - Supports up to 256 ECC endpoints (either ECC RAM or interconnect ECC component)
 - Single bit error detection via parity checking results in a non-correctable error interrupt

This page intentionally left blank.



This chapter summarizes the memory map address regions for the device.

2.1 Device Memory Map	24
------------------------------------	-----------

2.1 Device Memory Map

This section describes the device memory map.

Note

The memory locations not shown are either unallocated or reserved and not used.

Accesses to these locations are not recommended and should be avoided.

Table 2-1. AM263x Memory Map

Region Name	Start Address	End Address	Size
Core-specific Internal Memory Map ⁽¹⁾	0x0000 0000	0x1FFF FFFF	~537 MB
MCRC0	0x3500 0000	0x3500 03FF	1 KB
MPU_L2OCRAM_BANK0	0x4002 0000	0x4002 0FFF	4 KB
MPU_L2OCRAM_BANK1	0x4004 0000	0x4004 0FFF	4 KB
MPU_L2OCRAM_BANK2	0x4006 0000	0x4006 0FFF	4 KB
MPU_L2OCRAM_BANK3	0x4008 0000	0x4008 0FFF	4 KB
MPU_R5FSS0_CORE0_AXIS	0x400A 0000	0x400A 0FFF	4 KB
MPU_R5FSS0_CORE1_AXIS	0x400C 0000	0x400C 0FFF	4 KB
MPU_R5FSS1_CORE0_AXIS	0x400E 0000	0x400E 0FFF	4 KB
MPU_R5FSS1_CORE1_AXIS	0x4010 0000	0x4010 0FFF	4 KB
MPU_HSM_DTHE	0x4012 0000	0x4012 0FFF	4 KB
MPU_MBOX_SRAM	0x4014 0000	0x4014 0FFF	4 KB
MPU_QSPI0	0x4016 0000	0x4016 0FFF	4 KB
MPU_SCRM2SCRPO	0x4018 0000	0x4018 0FFF	4 KB
MPU_SCRM2SCRPI	0x401A 0000	0x401A 0FFF	4 KB
MPU_R5FSS0_CORE0_AHB	0x401C 0000	0x401C 0FFF	4 KB
MPU_R5FSS0_CORE1_AHB	0x401E 0000	0x401E 0FFF	4 KB
MPU_R5FSS1_CORE0_AHB	0x4020 0000	0x4020 0FFF	4 KB
MPU_R5FSS1_CORE1_AHB	0x4022 0000	0x4022 0FFF	4 KB
MPU_HSM	0x4024 0000	0x4024 0FFF	4 KB
HSM_INTERNAL ⁽¹⁾	0x40F7 8000	0x47FF FFFF	118 MB
ICSSM0_INTERNAL ⁽¹⁾	0x4800 0000	0x4803 FFFF	256 KB
ICSSM0_ECC	0x4810 0000	0x4810 03FF	1 KB
QSPI0	0x4820 0000	0x4820 01FF	512 Bytes
MMC0	0x4830 0000	0x4830 1FFF	8 KB
GPMC0_CFG	0x4840 0000	0x4840 03FF	1 KB
CONTROLSS_G0_EPWM0	0x5000 0000	0x5000 0FFF	4 KB
CONTROLSS_G0_EPWM1	0x5000 1000	0x5000 1FFF	4 KB
CONTROLSS_G0_EPWM2	0x5000 2000	0x5000 2FFF	4 KB
CONTROLSS_G0_EPWM3	0x5000 3000	0x5000 3FFF	4 KB
CONTROLSS_G0_EPWM4	0x5000 4000	0x5000 4FFF	4 KB
CONTROLSS_G0_EPWM5	0x5000 5000	0x5000 5FFF	4 KB
CONTROLSS_G0_EPWM6	0x50006000	0x5000 6FFF	4 KB
CONTROLSS_G0_EPWM7	0x5000 7000	0x5000 7FFF	4 KB
CONTROLSS_G0_EPWM8	0x5000 8000	0x5000 8FFF	4 KB
CONTROLSS_G0_EPWM9	0x5000 9000	0x5000 9FFF	4 KB
CONTROLSS_G0_EPWM10	0x5000 A000	0x5000 AFFF	4 KB
CONTROLSS_G0_EPWM11	0x5000 B000	0x5000 BFFF	4 KB

Table 2-1. AM263x Memory Map (continued)

Region Name	Start Address	End Address	Size
CONTROLSS_G0_EPWM12	0x5000 C000	0x5000 CFFF	4 KB
CONTROLSS_G0_EPWM13	0x5000 D000	0x5000 DFFF	4 KB
CONTROLSS_G0_EPWM14	0x5000 E000	0x5000 EFFF	4 KB
CONTROLSS_G0_EPWM15	0x5000 F000	0x5000 FFFF	4 KB
CONTROLSS_G0_EPWM16	0x5001 0000	0x5001 0FFF	4 KB
CONTROLSS_G0_EPWM17	0x5001 1000	0x5001 1FFF	4 KB
CONTROLSS_G0_EPWM18	0x5001 2000	0x5001 2FFF	4 KB
CONTROLSS_G0_EPWM19	0x5001 3000	0x5001 3FFF	4 KB
CONTROLSS_G0_EPWM20	0x5001 4000	0x5001 4FFF	4 KB
CONTROLSS_G0_EPWM21	0x5001 5000	0x5001 5FFF	4 KB
CONTROLSS_G0_EPWM22	0x5001 6000	0x5001 6FFF	4 KB
CONTROLSS_G0_EPWM23	0x5001 7000	0x5001 7FFF	4 KB
CONTROLSS_G0_EPWM24	0x5001 8000	0x5001 8FFF	4 KB
CONTROLSS_G0_EPWM25	0x5001 9000	0x5001 9FFF	4 KB
CONTROLSS_G0_EPWM26	0x5001 A000	0x5001 AFFF	4 KB
CONTROLSS_G0_EPWM27	0x5001 B000	0x5001 BFFF	4 KB
CONTROLSS_G0_EPWM28	0x5001 C000	0x5001 CFFF	4 KB
CONTROLSS_G0_EPWM29	0x5001 D000	0x5001 DFFF	4 KB
CONTROLSS_G0_EPWM30	0x5001 E000	0x5001 EFFF	4 KB
CONTROLSS_G0_EPWM31	0x5001 F000	0x5001 FFFF	4 KB
CONTROLSS_G1_EPWM0	0x5004 0000	0x5004 0FFF	4 KB
CONTROLSS_G1_EPWM1	0x5004 1000	0x5004 1FFF	4 KB
CONTROLSS_G1_EPWM2	0x5004 2000	0x5004 2FFF	4 KB
CONTROLSS_G1_EPWM3	0x5004 3000	0x5004 3FFF	4 KB
CONTROLSS_G1_EPWM4	0x5004 4000	0x5004 4FFF	4 KB
CONTROLSS_G1_EPWM5	0x5004 5000	0x5004 5FFF	4 KB
CONTROLSS_G1_EPWM6	0x5004 6000	0x5004 6FFF	4 KB
CONTROLSS_G1_EPWM7	0x5004 7000	0x5004 7FFF	4 KB
CONTROLSS_G1_EPWM8	0x5004 8000	0x5004 8FFF	4 KB
CONTROLSS_G1_EPWM9	0x5004 9000	0x5004 9FFF	4 KB
CONTROLSS_G1_EPWM10	0x5004 A000	0x5004 AFFF	4 KB
CONTROLSS_G1_EPWM11	0x5004 B000	0x5004 BFFF	4 KB
CONTROLSS_G1_EPWM12	0x5004 C000	0x5004 CFFF	4 KB
CONTROLSS_G1_EPWM13	0x5004 D000	0x5004 DFFF	4 KB
CONTROLSS_G1_EPWM14	0x5004 E000	0x5004 EFFF	4 KB
CONTROLSS_G1_EPWM15	0x5004 F000	0x5004 FFFF	4 KB
CONTROLSS_G1_EPWM16	0x5005 0000	0x5005 0FFF	4 KB
CONTROLSS_G1_EPWM17	0x5005 1000	0x5005 1FFF	4 KB
CONTROLSS_G1_EPWM18	0x5005 2000	0x5005 2FFF	4 KB
CONTROLSS_G1_EPWM19	0x5005 3000	0x5005 3FFF	4 KB
CONTROLSS_G1_EPWM20	0x5005 4000	0x5005 4FFF	4 KB
CONTROLSS_G1_EPWM21	0x5005 5000	0x5005 5FFF	4 KB
CONTROLSS_G1_EPWM22	0x5005 6000	0x5005 6FFF	4 KB
CONTROLSS_G1_EPWM23	0x5005 7000	0x5005 7FFF	4 KB
CONTROLSS_G1_EPWM24	0x5005 8000	0x5005 8FFF	4 KB

Table 2-1. AM263x Memory Map (continued)

Region Name	Start Address	End Address	Size
CONTROLSS_G1_EPWM25	0x5005 9000	0x5005 9FFF	4 KB
CONTROLSS_G1_EPWM26	0x5005 A000	0x5005 AFFF	4 KB
CONTROLSS_G1_EPWM27	0x5005 B000	0x5005 BFFF	4 KB
CONTROLSS_G1_EPWM28	0x5005 C000	0x5005 CFFF	4 KB
CONTROLSS_G1_EPWM29	0x5005 D000	0x5005 DFFF	4 KB
CONTROLSS_G1_EPWM30	0x5005 E000	0x5005 EFFF	4 KB
CONTROLSS_G1_EPWM31	0x5005 F000	0x5005 FFFF	4 KB
CONTROLSS_G2_EPWM0	0x5008 0000	0x5008 0FFF	4 KB
CONTROLSS_G2_EPWM1	0x5008 1000	0x5008 1FFF	4 KB
CONTROLSS_G2_EPWM2	0x5008 2000	0x5008 2FFF	4 KB
CONTROLSS_G2_EPWM3	0x5008 3000	0x5008 3FFF	4 KB
CONTROLSS_G2_EPWM4	0x5008 4000	0x5008 4FFF	4 KB
CONTROLSS_G2_EPWM5	0x5008 5000	0x5008 5FFF	4 KB
CONTROLSS_G2_EPWM6	0x5008 6000	0x5008 6FFF	4 KB
CONTROLSS_G2_EPWM7	0x5008 7000	0x5008 7FFF	4 KB
CONTROLSS_G2_EPWM8	0x5008 8000	0x5008 8FFF	4 KB
CONTROLSS_G2_EPWM9	0x5008 9000	0x5008 9FFF	4 KB
CONTROLSS_G2_EPWM10	0x5008 A000	0x5008 AFFF	4 KB
CONTROLSS_G2_EPWM11	0x5008 B000	0x5008 BFFF	4 KB
CONTROLSS_G2_EPWM12	0x5008 C000	0x5008 CFFF	4 KB
CONTROLSS_G2_EPWM13	0x5008 D000	0x5008 DFFF	4 KB
CONTROLSS_G2_EPWM14	0x5008 E000	0x5008 EFFF	4 KB
CONTROLSS_G2_EPWM15	0x5008 F000	0x5008 FFFF	4 KB
CONTROLSS_G2_EPWM16	0x5009 0000	0x5009 0FFF	4 KB
CONTROLSS_G2_EPWM17	0x5009 1000	0x5009 1FFF	4 KB
CONTROLSS_G2_EPWM18	0x5009 2000	0x5009 2FFF	4 KB
CONTROLSS_G2_EPWM19	0x5009 3000	0x5009 3FFF	4 KB
CONTROLSS_G2_EPWM20	0x5009 4000	0x5009 4FFF	4 KB
CONTROLSS_G2_EPWM21	0x5009 5000	0x5009 5FFF	4 KB
CONTROLSS_G2_EPWM22	0x5009 6000	0x5009 6FFF	4 KB
CONTROLSS_G2_EPWM23	0x5009 7000	0x5009 7FFF	4 KB
CONTROLSS_G2_EPWM24	0x5009 8000	0x5009 8FFF	4 KB
CONTROLSS_G2_EPWM25	0x5009 9000	0x5009 9FFF	4 KB
CONTROLSS_G2_EPWM26	0x5009 A000	0x5009 AFFF	4 KB
CONTROLSS_G2_EPWM27	0x5009 B000	0x5009 BFFF	4 KB
CONTROLSS_G2_EPWM28	0x5009 C000	0x5009 CFFF	4 KB
CONTROLSS_G2_EPWM29	0x5009 D000	0x5009 DFFF	4 KB
CONTROLSS_G2_EPWM30	0x5009 E000	0x5009 EFFF	4 KB
CONTROLSS_G2_EPWM31	0x5009 F000	0x5009 FFFF	4 KB
CONTROLSS_G3_EPWM0	0x500C 0000	0x500C 0FFF	4 KB
CONTROLSS_G3_EPWM1	0x500C 1000	0x500C 1FFF	4 KB
CONTROLSS_G3_EPWM2	0x500C 2000	0x500C 2FFF	4 KB
CONTROLSS_G3_EPWM3	0x500C 3000	0x500C 3FFF	4 KB
CONTROLSS_G3_EPWM4	0x500C 4000	0x500C 4FFF	4 KB
CONTROLSS_G3_EPWM5	0x500C 5000	0x500C 5FFF	4 KB

Table 2-1. AM263x Memory Map (continued)

Region Name	Start Address	End Address	Size
CONTROLSS_G3_EPWM6	0x500C 6000	0x500C 6FFF	4 KB
CONTROLSS_G3_EPWM7	0x500C 7000	0x500C 7FFF	4 KB
CONTROLSS_G3_EPWM8	0x500C 8000	0x500C 8FFF	4 KB
CONTROLSS_G3_EPWM9	0x500C 9000	0x500C 9FFF	4 KB
CONTROLSS_G3_EPWM10	0x500C A000	0x500C AFFF	4 KB
CONTROLSS_G3_EPWM11	0x500C B000	0x500C BFFF	4 KB
CONTROLSS_G3_EPWM12	0x500C C000	0x500C CFFF	4 KB
CONTROLSS_G3_EPWM13	0x500C D000	0x500C DFFF	4 KB
CONTROLSS_G3_EPWM14	0x500C E000	0x500C EFFF	4 KB
CONTROLSS_G3_EPWM15	0x500C F000	0x500C FFFF	4 KB
CONTROLSS_G3_EPWM16	0x500D 0000	0x500D 0FFF	4 KB
CONTROLSS_G3_EPWM17	0x500D 1000	0x500D 1FFF	4 KB
CONTROLSS_G3_EPWM18	0x500D 2000	0x500D 2FFF	4 KB
CONTROLSS_G3_EPWM19	0x500D 3000	0x500D 3FFF	4 KB
CONTROLSS_G3_EPWM20	0x500D 4000	0x500D 4FFF	4 KB
CONTROLSS_G3_EPWM21	0x500D 5000	0x500D 5FFF	4 KB
CONTROLSS_G3_EPWM22	0x500D 6000	0x500D 6FFF	4 KB
CONTROLSS_G3_EPWM23	0x500D 7000	0x500D 7FFF	4 KB
CONTROLSS_G3_EPWM24	0x500D 8000	0x500D 8FFF	4 KB
CONTROLSS_G3_EPWM25	0x500D 9000	0x500D 9FFF	4 KB
CONTROLSS_G3_EPWM26	0x500D A000	0x500D AFFF	4 KB
CONTROLSS_G3_EPWM27	0x500D B000	0x500D BFFF	4 KB
CONTROLSS_G3_EPWM28	0x500D C000	0x500D CFFF	4 KB
CONTROLSS_G3_EPWM29	0x500D D000	0x500D DFFF	4 KB
CONTROLSS_G3_EPWM30	0x500D E000	0x500D EFFF	4 KB
CONTROLSS_G3_EPWM31	0x500D F000	0x500D FFFF	4 KB
CONTROLSS_ADC0_RESULT	0x5010 0000	0x5010 0FFF	4 KB
CONTROLSS_ADC1_RESULT	0x5010 1000	0x5010 1FFF	4 KB
CONTROLSS_ADC2_RESULT	0x5010 2000	0x5010 2FFF	4 KB
CONTROLSS_ADC3_RESULT	0x5010 3000	0x5010 3FFF	4 KB
CONTROLSS_ADC4_RESULT	0x5010 4000	0x5010 4FFF	4 KB
CONTROLSS_CMPSSA0	0x5020 0000	0x5020 0FFF	4 KB
CONTROLSS_CMPSSA1	0x5020 1000	0x5020 1FFF	4 KB
CONTROLSS_CMPSSA2	0x5020 2000	0x5020 2FFF	4 KB
CONTROLSS_CMPSSA3	0x5020 3000	0x5020 3FFF	4 KB
CONTROLSS_CMPSSA4	0x5020 4000	0x5020 4FFF	4 KB
CONTROLSS_CMPSSA5	0x5020 5000	0x5020 5FFF	4 KB
CONTROLSS_CMPSSA6	0x5020 6000	0x5020 6FFF	4 KB
CONTROLSS_CMPSSA7	0x5020 7000	0x5020 7FFF	4 KB
CONTROLSS_CMPSSA8	0x5020 8000	0x5020 8FFF	4 KB
CONTROLSS_CMPSSA9	0x5020 9000	0x5020 9FFF	4 KB
CONTROLSS_CMPSSB0	0x5022 0000	0x5022 0FFF	4 KB
CONTROLSS_CMPSSB1	0x5022 1000	0x5022 1FFF	4 KB
CONTROLSS_CMPSSB2	0x5022 2000	0x5022 2FFF	4 KB
CONTROLSS_CMPSSB3	0x5022 3000	0x5022 3FFF	4 KB

Table 2-1. AM263x Memory Map (continued)

Region Name	Start Address	End Address	Size
CONTROLSS_CMPSSB4	0x5022 4000	0x5022 4FFF	4 KB
CONTROLSS_CMPSSB5	0x5022 5000	0x5022 5FFF	4 KB
CONTROLSS_CMPSSB6	0x5022 6000	0x5022 6FFF	4 KB
CONTROLSS_CMPSSB7	0x5022 7000	0x5022 7FFF	4 KB
CONTROLSS_CMPSSB8	0x5022 8000	0x5022 8FFF	4 KB
CONTROLSS_CMPSSB9	0x5022 9000	0x5022 9FFF	4 KB
CONTROLSS_ECAP0	0x5024 0000	0x5024 0FFF	4 KB
CONTROLSS_ECAP1	0x5024 1000	0x5024 1FFF	4 KB
CONTROLSS_ECAP2	0x5024 2000	0x5024 2FFF	4 KB
CONTROLSS_ECAP3	0x5024 3000	0x5024 3FFF	4 KB
CONTROLSS_ECAP4	0x5024 4000	0x5024 4FFF	4 KB
CONTROLSS_ECAP5	0x5024 5000	0x5024 5FFF	4 KB
CONTROLSS_ECAP6	0x5024 6000	0x5024 6FFF	4 KB
CONTROLSS_ECAP7	0x5024 7000	0x5024 7FFF	4 KB
CONTROLSS_ECAP8	0x5024 8000	0x5024 8FFF	4 KB
CONTROLSS_ECAP9	0x5024 9000	0x5024 9FFF	4 KB
CONTROLSS_DAC0	0x5026 0000	0x5026 0FFF	4 KB
CONTROLSS_SDFM0	0x5026 8000	0x5026 8FFF	4 KB
CONTROLSS_SDFM1	0x5026 9000	0x5026 9FFF	4 KB
CONTROLSS_EQEP0	0x5027 0000	0x5027 0FFF	4 KB
CONTROLSS_EQEP1	0x5027 1000	0x5027 1FFF	4 KB
CONTROLSS_EQEP2	0x50272000	0x5027 2FFF	4 KB
CONTROLSS_FSI0_TX0	0x5028 0000	0x5028 0FFF	4 KB
CONTROLSS_FSI0_TX1	0x5028 1000	0x5028 1FFF	4 KB
CONTROLSS_FSI0_RX0	0x5029 0000	0x5029 0FFF	4 KB
CONTROLSS_FSI0_RX1	0x5029 1000	0x5029 1FFF	4 KB
CONTROLSS_FSI1_TX2	0x502A 0000	0x502A 0FFF	4 KB
CONTROLSS_FSI1_TX3	0x502A 1000	0x502A 1FFF	4 KB
CONTROLSS_FSI1_RX2	0x502B 0000	0x502B 0FFF	4 KB
CONTROLSS_FSI1_RX3	0x502B 1000	0x502B 1FFF	4 KB
CONTROLSS_ADC0_CFG	0x502C 0000	0x502C 0FFF	4 KB
CONTROLSS_ADC1_CFG	0x502C 1000	0x502C 1FFF	4 KB
CONTROLSS_ADC2_CFG	0x502C 2000	0x502C 2FFF	4 KB
CONTROLSS_ADC3_CFG	0x502C 3000	0x502C 3FFF	4 KB
CONTROLSS_ADC4_CFG	0x502C 4000	0x502C 4FFF	4 KB
CONTROLSS_INPUTXBAR	0x502D 0000	0x502D 0FFF	4 KB
CONTROLSS_PWMXBAR	0x502D 1000	0x502D 1FFF	4 KB
CONTROLSS_PWMSYNCOUXTXBAR	0x502D 2000	0x502D 2FFF	4 KB
CONTROLSS_INTXBAR	0x502D 5000	0x502D 5FFF	4 KB
CONTROLSS_DMAXBAR	0x502D 6000	0x502D 6FFF	4 KB
CONTROLSS_OUTPUTXBAR	0x502D 8000	0x502D 8FFF	4 KB
CONTROLSS_OTTOCAL0	0x502E 0000	0x502E 0FFF	4 KB
CONTROLSS_OTTOCAL1	0x502E 1000	0x502E 1FFF	4 KB
CONTROLSS_OTTOCAL2	0x502E 2000	0x502E 2FFF	4 KB
CONTROLSS_OTTOCAL3	0x502E 3000	0x502E 3FFF	4 KB

Table 2-1. AM263x Memory Map (continued)

Region Name	Start Address	End Address	Size
CONTROLSS_CTRL	0x502F 0000	0x502F 7FFF	32 KB
DEBUGSS	0x5080 0000	0x508F FFFF	1024 KB
MSS_CTRL	0x50D0 0000	0x50D3 FFFF	256 KB
TOP_CTRL	0x50D8 0000	0x50D8 7FFF	32 KB
SPINLOCK0	0x50E0 0000	0x50E0 7FFF	32 KB
VIM	0x50F0 0000	0x50F0 3FFF	16 KB
GPIO0	0x5200 0000	0x5200 00FF	256 Bytes
GPIO1	0x5200 1000	0x5200 10FF	256 Bytes
GPIO2	0x5200 2000	0x5200 20FF	256 Bytes
GPIO3	0x5200 3000	0x5200 30FF	256 Bytes
WDT0	0x5210 0000	0x5210 00FF	256 Bytes
WDT1	0x5210 1000	0x5210 10FF	256 Bytes
WDT2	0x5210 2000	0x5210 20FF	256 Bytes
WDT3	0x5210 3000	0x5210 30FF	256 Bytes
RTI0	0x5218 0000	0x5218 03FF	1 KB
RTI1	0x5218 1000	0x5218 13FF	1 KB
RTI2	0x5218 2000	0x5218 23FF	1 KB
RTI3	0x5218 3000	0x5218 33FF	1 KB
MCSPi0	0x5220 0000	0x5220 01FF	512 Bytes
MCSPi1	0x5220 1000	0x5220 11FF	512 Bytes
MCSPi2	0x5220 2000	0x5220 21FF	512 Bytes
MCSPi3	0x5220 3000	0x5220 31FF	512 Bytes
MCSPi4	0x5220 4000	0x5220 41FF	512 Bytes
UART0	0x5230 0000	0x5230 01FF	512 Bytes
UART1	0x5230 1000	0x5230 11FF	512 Bytes
UART2	0x5230 2000	0x5230 21FF	512 Bytes
UART3	0x5230 3000	0x5230 31FF	512 Bytes
UART4	0x5230 4000	0x5230 41FF	512 Bytes
UART5	0x5230 5000	0x5230 51FF	512 Bytes
LIN0	0x5240 0000	0x5240 00FF	256 Bytes
LIN1	0x5240 1000	0x5240 10FF	256 Bytes
LIN2	0x5240 2000	0x5240 20FF	256 Bytes
LIN3	0x5240 3000	0x5240 30FF	256 Bytes
LIN4	0x5240 4000	0x5240 40FF	256 Bytes
I2C0	0x5250 0000	0x5250 00FF	256 Bytes
I2C1	0x5250 1000	0x5250 10FF	256 Bytes
I2C2	0x5250 2000	0x5250 20FF	256 Bytes
I2C3	0x5250 3000	0x5250 30FF	256 Bytes
MCAN0_MSG_RAM	0x5260 0000	0x5260 7FFF	32 KB
MCAN0_CFG	0x5260 8000	0x5260 83FF	1 KB
MCAN1_MSG_RAM	0x52610000	0x5261 7FFF	32 KB
MCAN1_CFG	0x5261 8000	0x5261 83FF	1 KB
MCAN2_MSG_RAM	0x5262 0000	0x5262 7FFF	32 KB
MCAN2_CFG	0x5262 8000	0x5262 83FF	1 KB
MCAN3_MSG_RAM	0x5263 0000	0x5263 7FFF	32 KB

Table 2-1. AM263x Memory Map (continued)

Region Name	Start Address	End Address	Size
MCAN3_CFG	0x5263 8000	0x5263 83FF	1 KB
MCAN0_ECC	0x5270 0000	0x5270 03FF	1 KB
MCAN1_ECC	0x5270 1000	0x5270 13FF	1 KB
MCAN2_ECC	0x5270 2000	0x5270 23FF	1 KB
MCAN3_ECC	0x5270 3000	0x5270 33FF	1 KB
ELM0	0x527F 0000	0x527F 0FFF	4 KB
CPSW0	0x5280 0000	0x529F FFFF	2 MB
TPCC0	0x52A0 0000	0x52A0 7FFF	32 KB
TPTC00	0x52A40000	0x52A4 0FFF	4 KB
TPTC01	0x52A6 0000	0x52A6 0FFF	4 KB
DCC0	0x52B0 0000	0x52B0 00FF	256 Bytes
DCC1	0x52B0 1000	0x52B0 10FF	256 Bytes
DCC2	0x52B0 2000	0x52B0 20FF	256 Bytes
DCC3	0x52B0 3000	0x52B0 30FF	256 Bytes
TOP_ESM	0x52D0 0000	0x52D0 0FFF	4 KB
SOC_TIMESYNC_XBAR0	0x52E0 0000	0x52E0 00FF	256 Bytes
EDMA_TRIG_XBAR	0x52E0 1000	0x52E0 11FF	512 Bytes
GPIO_INTR_XBAR	0x52E0 2000	0x52E0 23FF	1 KB
ICSSM_INTR_XBAR	0x52E0 3000	0x52E0 30FF	256 Bytes
SOC_TIMESYNC_XBAR1	0x52E0 4000	0x52E0 43FF	1 KB
ECC_AGG_R5FSS0_CORE0	0x5300 0000	0x5300 03FF	1 KB
ECC_AGG_R5FSS0_CORE1	0x5300 3000	0x5300 33FF	1 KB
ECC_AGG_R5FSS1_CORE0	0x5300 4000	0x5300 43FF	1 KB
ECC_AGG_R5FSS1_CORE1	0x5300 7000	0x5300 73FF	1 KB
ECC_AGG_TOP	0x5301 0000	0x5301 03FF	1 KB
IOMUX	0x5310 0000	0x5310 0FFF	4 KB
TOP_RCM	0x5320 0000	0x5320 7FFF	32 KB
MSS_RCM	0x5320 8000	0x5320 FFFF	32 KB
R5FSS0_CCMR	0x5321 0000	0x5321 0FFF	4 KB
R5FSS1_CCMR	0x5321 1000	0x5321 1FFF	4 KB
TOP_PBIIST	0x5330 0000	0x5330 03FF	1 KB
R5FSS0_STC	0x5350 0000	0x5350 01FF	512 Bytes
R5FSS1_STC	0x5351 0000	0x5351 01FF	512 Bytes
TOP_EFUSE_FARM	0x5360 0000	0x5360 00FF	256 Bytes
EXT_FLASH0	0x6000 0000	0x61FF FFFF	32 MB
EXT_FLASH1	0x6200 0000	0x63FF FFFF	32 MB
GPMC0_MEM	0x6800 0000	0x6FFF FFFF	128 MB
L2OCRAM	0x7000 0000	0x701F FFFF	2 MB
MBOX_SRAM	0x7200 0000	0x7200 3FFF	16 KB
R5FSS0_CORE0_ICACHE ⁽⁴⁾	0x7400 0000	0x747F FFFF	16 KB (8 MB) ⁽⁵⁾
R5FSS0_CORE0_DCACHE ⁽⁴⁾	0x7480 0000	0x74FF FFFF	16 KB (8 MB) ⁽⁵⁾
R5FSS0_CORE1_ICACHE ^{(2) (4)}	0x7500 0000	0x757F FFFF	16 KB (8 MB) ⁽⁵⁾
R5FSS0_CORE1_DCACHE ^{(2) (4)}	0x7580 0000	0x75FF FFFF	16 KB (8 MB) ⁽⁵⁾
R5FSS1_CORE0_ICACHE ⁽⁴⁾	0x7600 0000	0x767F FFFF	16 KB (8 MB) ⁽⁵⁾
R5FSS1_CORE0_DCACHE ⁽⁴⁾	0x7680 0000	0x76FF FFFF	16 KB (8 MB) ⁽⁵⁾

Table 2-1. AM263x Memory Map (continued)

Region Name	Start Address	End Address	Size
R5FSS1_CORE1_ICACHE ^{(2) (4)}	0x7700 0000	0x777F FFFF	16 KB (8 MB) ⁽⁵⁾
R5FSS1_CORE1_DCACHE ^{(2) (4)}	0x7780 0000	0x77FF FFFF	16 KB (8 MB) ⁽⁵⁾
R5FSS0_CORE0_TCMA ^{(3) (4)}	0x7800 0000	0x7800 FFFF	64 KB
R5FSS0_CORE0_TCMB ^{(3) (4)}	0x7810 0000	0x7810 FFFF	64 KB
R5FSS0_CORE1_TCMA ^{(2) (4)}	0x7820 0000	0x7820 7FFF	32 KB
R5FSS0_CORE1_TCMB ^{(2) (4)}	0x7830 0000	0x7830 7FFF	32 KB
R5FSS1_CORE0_TCMA ^{(3) (4)}	0x7840 0000	0x7840 FFFF	64 KB
R5FSS1_CORE0_TCMB ^{(3) (4)}	0x7850 0000	0x7850 FFFF	64 KB
R5FSS1_CORE1_TCMA ^{(2) (4)}	0x7860 0000	0x7860 7FFF	32 KB
R5FSS1_CORE1_TCMB ^{(2) (4)}	0x7870 0000	0x7870 7FFF	32 KB

- (1) See core-specific tables for the internal memory map.
- (2) In Lockstep mode, the R5FSSx CORE1 memory region is not accessible.
- (3) The size of these memories will change based on Dual-Core vs Lockstep operation. For more information about Dual-Core and Lockstep modes, see the *R5FSS* chapter. For more information about ATCM and BTCM, see the *Tightly-Coupled Memories (TCM)* section within the *R5FSS* chapter.
- (4) This memory region is used by each CPU core to access the TCM/Cache memory space of other CPU cores.
- (5) Each R5FSS contains 16KB i-cache and 16KB d-cache. However, the system interconnect sees an 8MB address range at ICACHE/DCACHE. Any core attempting to access more than 16KB would wrap around and access the same cache multiple times.

This page intentionally left blank.



This chapter describes the device system interconnect.

3.1 System Interconnect Overview	34
3.2 CORE VBUSM Interconnect	35
3.3 CORE VBUSP Interconnect	37
3.4 PERI VBUSP Interconnect	40
3.5 INFRA0 VBUSP interconnect	43
3.6 INFRA1 VBUSP Interconnect	43
3.7 CONTROLSS interconnect	44
3.8 Memory Protection Units (MPU)	47

3.1 System Interconnect Overview

The device implements a system interconnect using TI's Common Bus Architecture (CBA), composed of the VBUSM and VBUSP protocols.

The system is based on a multi-layered interconnect approach designed to meet high-performance system requirements. The interconnect structure consists of a full crossbar implementation, where every initiator has an independent communication path with every target, such that, transactions from each initiator has access to full interconnect bandwidth. Arbitration will only happen at the target end point with round-robin prioritization. Targets cannot generate read/write requests directly. However, they can respond to these requests by generating error events (as defined by the CBA protocol), interrupts, and DMA requests.

The device interconnect is partitioned into the following sections:

- CORE VBUSM Interconnect
- CORE VBUSP Interconnect
- PERI VBUSP Interconnect
- INFRA0 VBUSP Interconnect
- INFRA1 VBUSP Interconnect
- CONTROLSS VBUSP Interconnect

3.2 CORE VBUSM Interconnect

The device Core Interconnect (CORE VBUSM) utilizes the VBUSM architecture to enable extensive transaction pipelining configuration along with support for multiple outstanding transactions; this dramatically increases system performance at the cost of higher complexity and additional logic. The diagram below shows the device peripherals with Core Interconnect target ports.

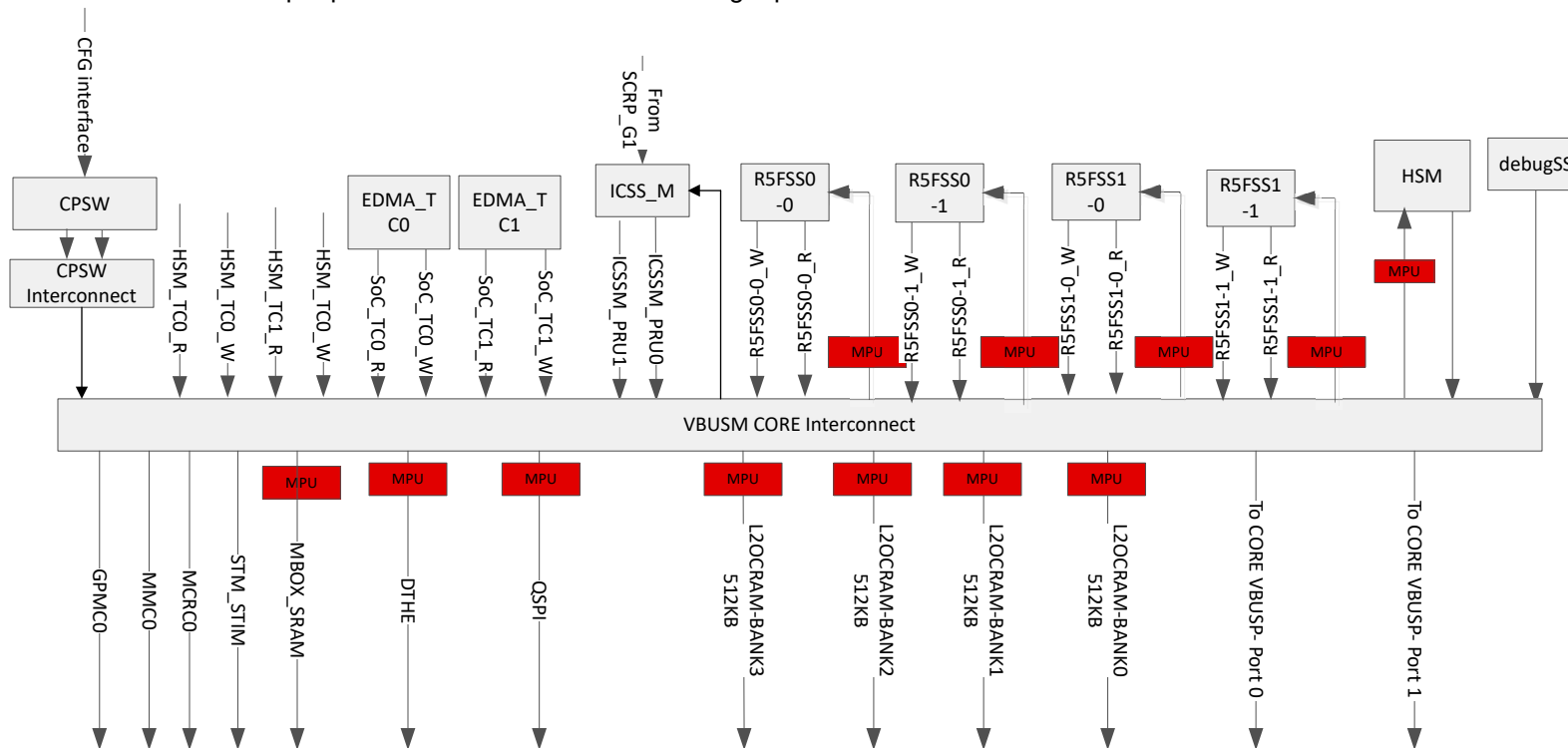

Figure 3-1. Core Interconnect Diagram

The red blocks in the diagram above indicate designated MPU (Memory protection units) on the associated target ports. They are used to protect data and configuration spaces by managing read/write access rights to the memory region. The AM263x device MPUs allow for up to 8 programmable regions. Additional details related the Memory Protection Unit, can be found in the device [MPU](#) chapter.

ADVANCE INFORMATION

Table 3-1. CORE VBUSM Initiator-Target Table

This table lists initiator and target end point connections for the CORE VBUSM Interconnect. A cell may contain one of the following:

- Y – Connection **does** exist between initiator and target.
- N – Connection **does NOT** exist between initiator and target.

Targets	Initiators												
	R5FSS 0-0*	R5FSS 0-1*	R5FSS 1-0*	R5FSS 1-1*	HSM	HSM_TC0 R/W*	HSM_TC1 R/W*	SoC_TC0 R/W*	SoC_TC1 R/W*	DEBUGSS	ICSSM PRU0	ICSSM PRU1	CPSW3G
R5FSS0-0	N	Y	Y	Y	Y	Y	Y	Y	Y	Y	Y	Y	Y
R5FSS0-1	Y	N	Y	Y	Y	Y	Y	Y	Y	Y	Y	Y	Y
R5FSS1-0^	Y	Y	N	Y	Y	Y	Y	Y	Y	Y	Y	Y	Y
R5FSS1-1^	Y	Y	Y	N	Y	Y	Y	Y	Y	Y	Y	Y	Y
OCSRAM (BANK0)	Y	Y	Y	Y	Y	Y	Y	Y	Y	Y	Y	Y	Y
OCSRAM (BANK1)	Y	Y	Y	Y	Y	Y	Y	Y	Y	Y	Y	Y	Y
OCSRAM (BANK2)	Y	Y	Y	Y	Y	Y	Y	Y	Y	Y	Y	Y	Y
OCSRAM (BANK3)	Y	Y	Y	Y	Y	Y	Y	Y	Y	Y	Y	Y	Y
MBOX_SRAM	Y	Y	Y	Y	Y	Y	Y	Y	Y	Y	Y	Y	Y
HSM	Y	Y	Y	Y	N	Y	Y	Y	Y	Y	Y	Y	Y
DTHE	Y	Y	Y	Y	Y	Y	Y	Y	Y	Y	Y	Y	Y
QSPI	Y	Y	Y	Y	Y	Y	Y	Y	Y	Y	Y	Y	Y
ICSSM	Y	Y	Y	Y	Y	Y	Y	Y	Y	Y	N	N	Y
MMC0	Y	Y	Y	Y	Y	Y	Y	Y	Y	Y	Y	Y	Y
STM_STIM	Y	Y	Y	Y	Y	Y	Y	Y	Y	Y	Y	Y	Y
MCRC	Y	Y	Y	Y	Y	Y	Y	Y	Y	Y	Y	Y	Y
GPMC	Y	Y	Y	Y	Y	Y	Y	Y	Y	Y	Y	Y	Y
CORE VBUSP (Port0)	N	N	N	N	N	Y	N	Y	N	Y	Y	N	N
CORE VBUSP (Port1)	N	N	N	N	Y	N	Y	N	Y	N	N	Y	N

Note

* These initiators have separate read and write ports.

Note

^ Accessible only with LOCKSTEP mode disabled. Any access with LOCKSTEP mode enabled will result in error response.

3.3 CORE VBUSP Interconnect

VBUSP is a very simple and easy to implement protocol that is pended such that only a single transaction can be outstanding at any given time. VBUSP protocol is classified as a point-to-point, pended interface protocol. The design is split into multi layers of VBUSP interconnect for performance requirements. The diagram below shows the peripherals which are target ports for the CORE VBUSP interconnect.

VIM interconnect are local VBUSP interconnect which allows low latency path from each R5SS to its own VIM module. Since this are locally connected before the CORE VBUSP interconnect, access is restricted only from each R5SS core to its own VIM module.

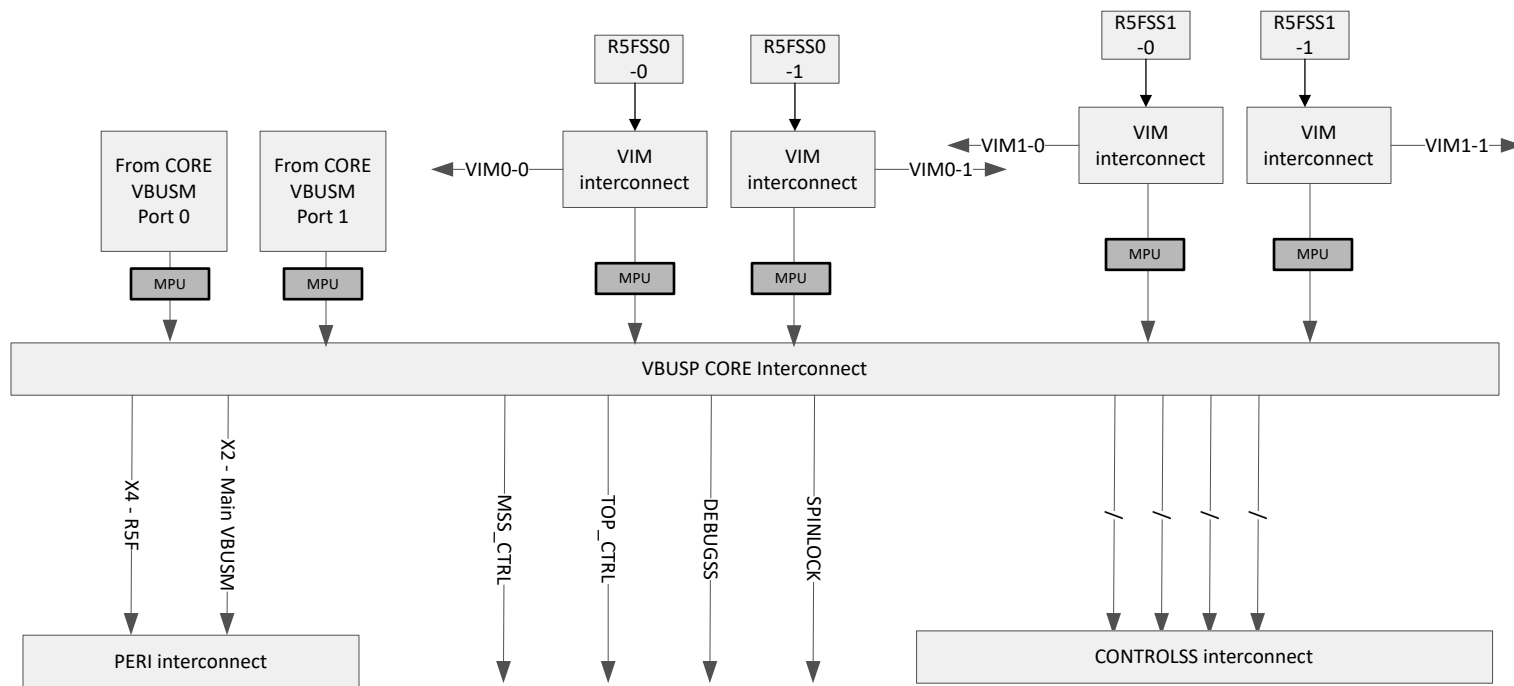

Figure 3-2. CORE VBUSP Interconnect Diagram

The grey blocks are MPU(Memory protection units) on the target ports. They are used to protect data and configuration spaces by managing the accesses to these memory regions. The MPUs above can have up to 16 programmable regions. For more details on MPU, please refer to [MPU](#).

ADVANCE INFORMATION

Table 3-2. CORE VBUSP Initiator-Target Table

This table lists the initiator and target end point connections for the CORE VBUSP Interconnect. A cell may contain one of the following:

- Y – Connection **does** exist between initiator and target.
- N – Connection **does NOT** exist between initiator and target.

Targets	Initiators					
	R5FSS 0-0_AHB	R5FSS 0-1_AHB	R5FSS 1-0_AHB	R5FSS 1-1_AHB	CORE VBUSP (Port0)	CORE VBUSP (Port1)
EPWM_G0	Y	Y	Y	Y	Y	Y
EPWM_G1	Y	Y	Y	Y	Y	Y
EPWM_G2	Y	Y	Y	Y	Y	Y
EPWM_G3	Y	Y	Y	Y	Y	Y
ADC_0	Y	N	N	N	N	N
ADC_1	N	Y	N	N	N	N
ADC_2	N	N	Y	N	N	N
ADC_3	N	N	N	Y	N	N
ADC_4	N	N	N	N	Y	N
ADC_5	N	N	N	N	N	Y
MISC PERIPH	Y	Y	Y	Y	Y	Y
FSI_0	Y	Y	Y	Y	Y	Y
FSI_1	Y	Y	Y	Y	Y	Y
MISC CONFIG	Y	Y	Y	Y	Y	Y
PERI_R5FSS0-0*	Y	N	N	N	N	N
PERI_R5FSS0-1*	N	Y	N	N	N	N
PERI_R5FSS1-0*	N	N	Y	N	N	N
PERI_R5FSS1-1*	N	N	N	Y	N	N
PERI VBUSP (Port0)*	N	N	N	N	Y	N
PERI VBUSP (Port1)*	N	N	N	N	N	Y
SPINLOCK	Y	Y	Y	Y	Y	Y
DEBUGSS	Y	Y	Y	Y	Y	Y
MSS_CTRL	Y	Y	Y	Y	Y	Y
TOP_CTRL	Y	Y	Y	Y	Y	Y
VIM0-0	Y	N	N	N	N	N
VIM0-1	N	Y	N	N	N	N
VIM1-0	N	N	Y	N	N	N
VIM1-1	N	N	N	Y	N	N

ADVANCE INFORMATION

Note

*These targets connect to initiator ports on the PERI interconnect.

3.4 PERI VBUSP Interconnect

PERI VBUSP interconnect connects with the CORE VBUSP interconnect through the target ports each dedicated for individual initiators on the CORE VBUSP. The diagram below shows the peripherals which are target ports for the CORE VBUSP interconnect.

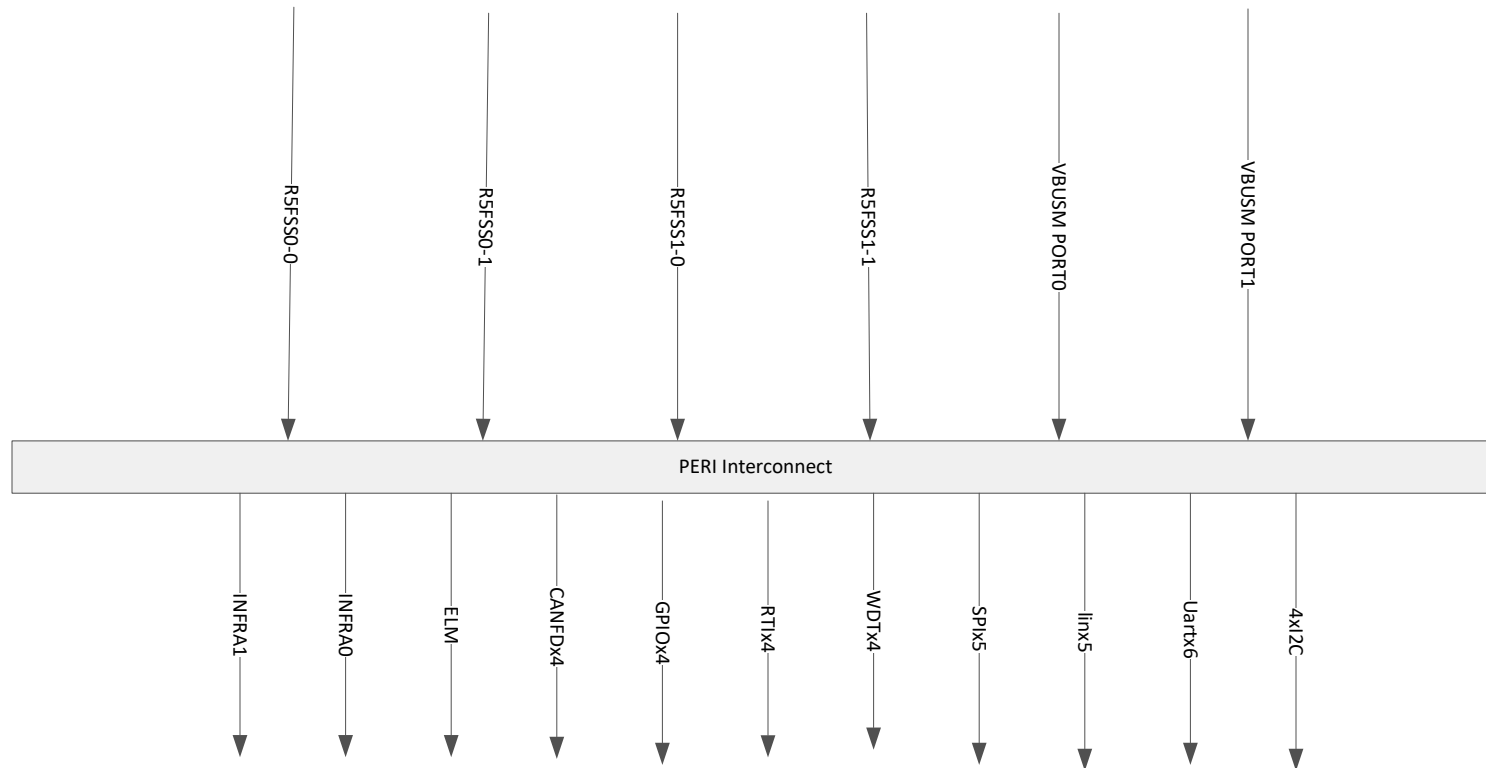

Figure 3-3. PERI VBUSP Interconnect Diagram

Table 3-3. PERI VBUSP Initiator-Target Table

This table lists initiator and target end point connections for the PERI VBUSP Interconnect. A cell may contain one of the following:

- Y – Connection **does** exist between initiator and target.
- N – Connection **does NOT** exist between initiator and target.

Targets	Initiators					
	R5FSS 0-0_AHB	R5FSS 0-1_AHB	R5FSS 1-0_AHB	R5FSS 1-1_AHB	PERI VBUSP (Port0)	PERI VBUSP (Port1)
GPIO0	Y	N	N	N	Y	Y
GPIO1	N	Y	N	N	Y	Y
GPIO2	N	N	Y	N	Y	Y
GPIO3	N	N	N	Y	Y	Y
WDT0	Y	N	N	N	Y	Y
WDT1	N	Y	N	N	Y	Y
WDT2	N	N	Y	N	Y	Y
WDT3	N	N	N	Y	Y	Y
SPI0	Y	Y	Y	Y	Y	Y
SPI1	Y	Y	Y	Y	Y	Y
SPI2	Y	Y	Y	Y	Y	Y
SPI3	Y	Y	Y	Y	Y	Y
SPI4	Y	Y	Y	Y	Y	Y
SPI5	Y	Y	Y	Y	Y	Y
UART0	Y	Y	Y	Y	Y	Y
UART1	Y	Y	Y	Y	Y	Y
UART2	Y	Y	Y	Y	Y	Y
UART3	Y	Y	Y	Y	Y	Y
UART4	Y	Y	Y	Y	Y	Y
UART5	Y	Y	Y	Y	Y	Y
LIN0	Y	Y	Y	Y	Y	Y
LIN1	Y	Y	Y	Y	Y	Y
LIN2	Y	Y	Y	Y	Y	Y
LIN3	Y	Y	Y	Y	Y	Y
LIN4	Y	Y	Y	Y	Y	Y
I2C0	Y	Y	Y	Y	Y	Y
I2C1	Y	Y	Y	Y	Y	Y
I2C2	Y	Y	Y	Y	Y	Y
I2C3	Y	Y	Y	Y	Y	Y
RTI0	Y	Y	Y	Y	Y	Y
RTI1	Y	Y	Y	Y	Y	Y

ADVANCE INFORMATION

Table 3-3. PERI VBUSP Initiator-Target Table (continued)

This table lists initiator and target end point connections for the PERI VBUSP Interconnect. A cell may contain one of the following:

- Y – Connection **does** exist between initiator and target.
- N – Connection **does NOT** exist between initiator and target.

Targets	Initiators					
	R5FSS 0-0_AHB	R5FSS 0-1_AHB	R5FSS 1-0_AHB	R5FSS 1-1_AHB	PERI VBUSP (Port0)	PERI VBUSP (Port1)
RTI2	Y	Y	Y	Y	Y	Y
RTI3	Y	Y	Y	Y	Y	Y
CANFD0	Y	Y	Y	Y	Y	Y
CANFD1	Y	Y	Y	Y	Y	Y
CANFD2	Y	Y	Y	Y	Y	Y
CANFD3	Y	Y	Y	Y	Y	Y
INFRA0	Y	Y	Y	Y	Y	Y
INFRA1	Y	Y	Y	Y	Y	Y

3.5 INFRA0 VBUSP interconnect

INFRA0 VBUSP interconnect connects with the PERI VBUSP interconnect through a single target port catering to all initiators on the PERI VBUSP. The diagram below shows the peripherals which are target ports for the INFRA0 VBUSP interconnect.

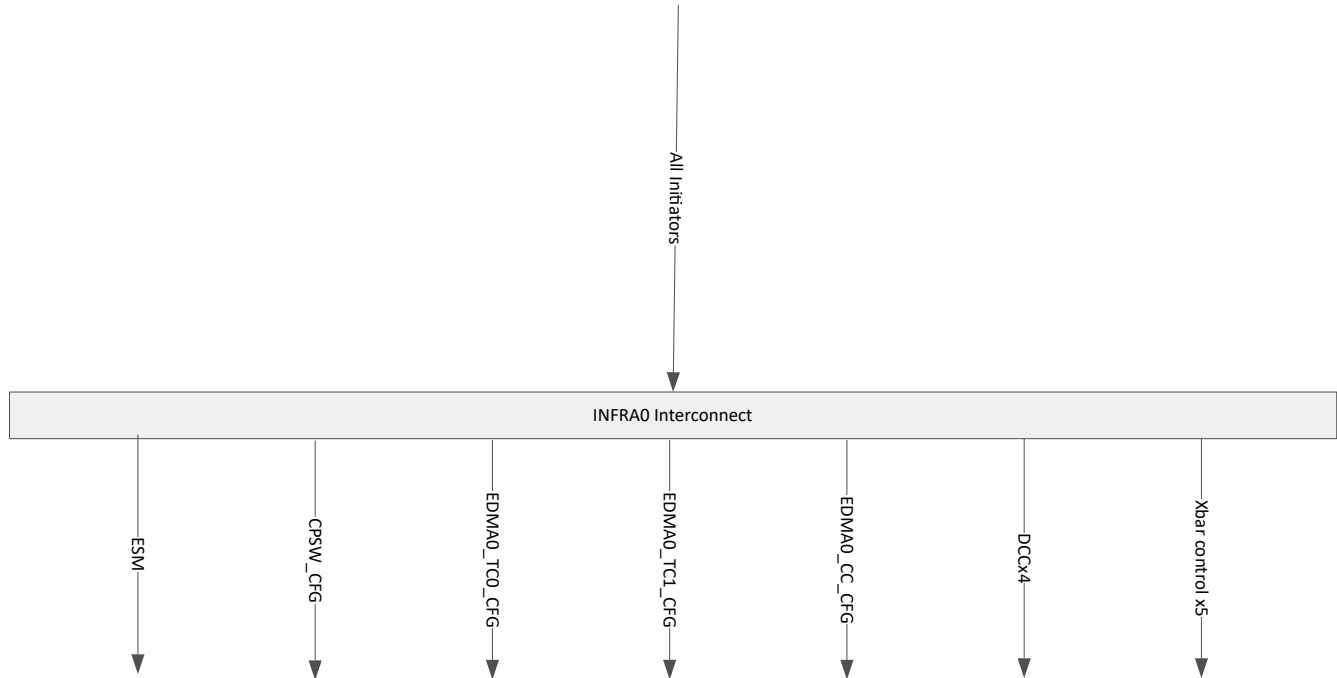

There is no access restriction since its a single initiator, multiple target interconnect.

3.6 INFRA1 VBUSP Interconnect

INFRA1 VBUSP interconnect connects with the PERI VBUSP interconnect through a single target port catering to all initiators on the PERI VBUSP. The diagram below shows the peripherals which are target ports for the INFRA1 VBUSP interconnect.

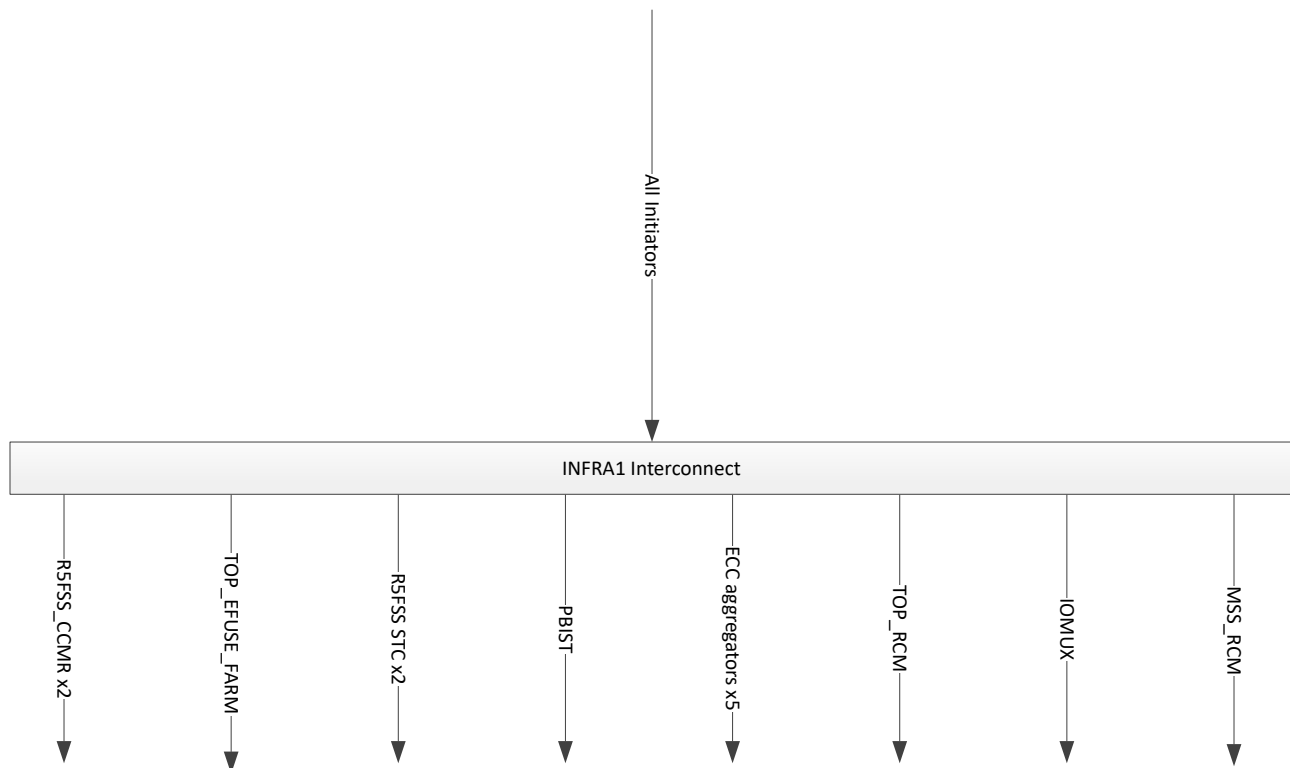

There is no access restriction since its a single initiator, multiple target interconnect.

3.7 CONTROLSS interconnect

CONTROLSS interconnect is divided into below list of separate interconnect connected to the CORE VBUSP interconnect individually. Since this are connected to the CORE VBUSP interconnect separately, each of this interconnect can be accessed parallelly by different initiators without any arbitration. Accessing a single CONTROLSS interconnect by multiple initiators at the same time will be arbitrated.

- MISC PERIPH
- MISC CONFIG
- FSIO
- FSIO
- G0_EPWM, G1_EPWM, G2_EPWM, G3_EPWM
- ADC0, ADC1, ADC2, ADC3, ADC4, ADC5

Below diagram shows the different interconnect connections.

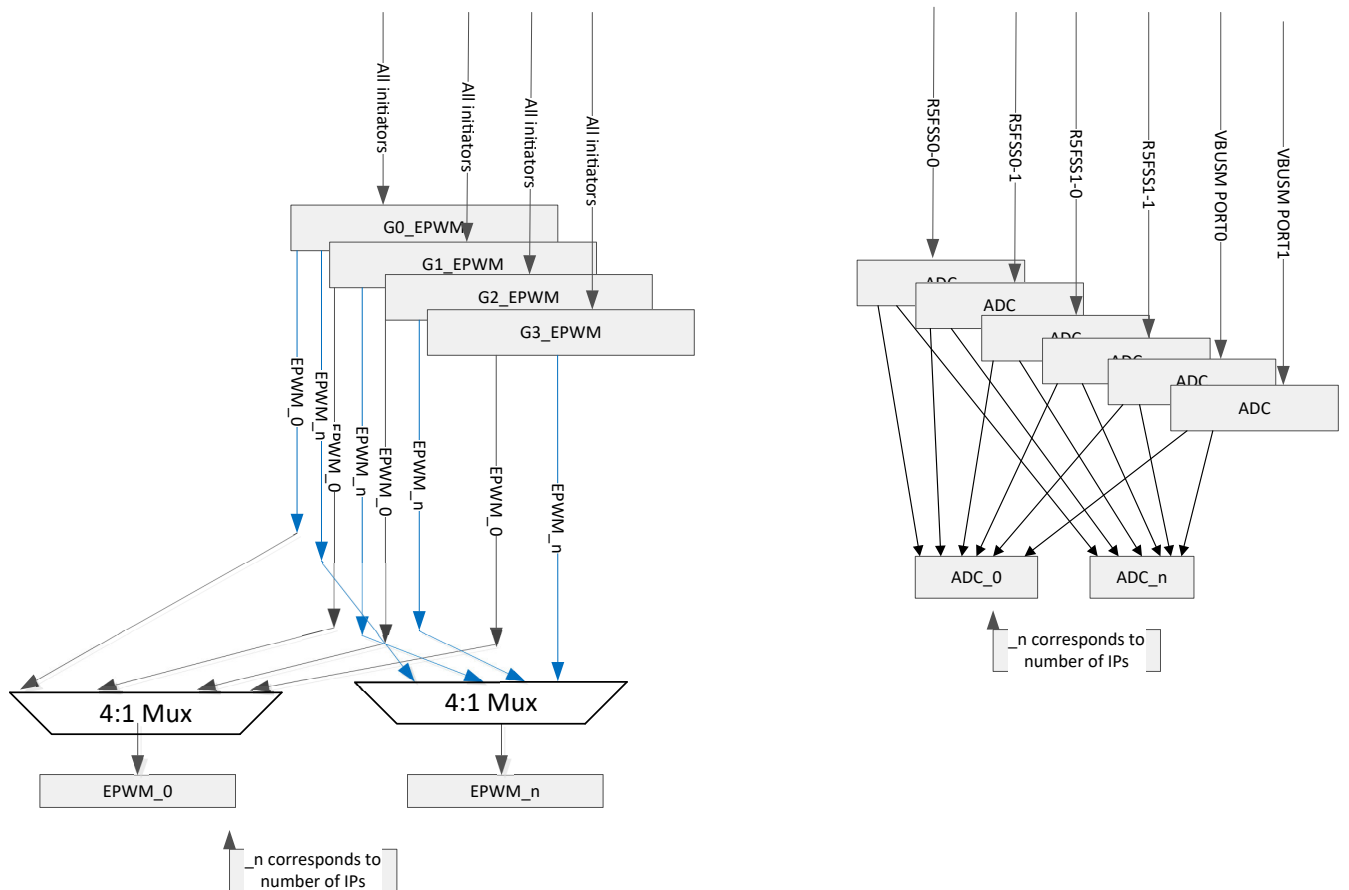
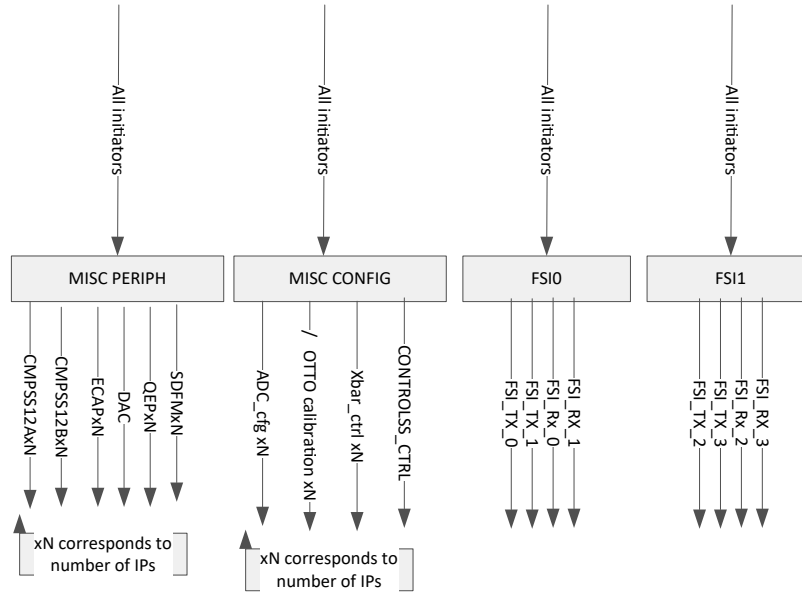

ADVANCE INFORMATION

MISC PERIPH, MISC CONFIG, FSI0 and FSI1 are single initiator, multiple targets as shown in the diagram. EPWM interconnect are divided into 4 groups G0_EPWM, G1_EPWM, G2_EPWM and G3_EPWM accessed using different address regions in the memory map. Each interconnect has n target ports depending on number of EPWM in the design. After the interconnect, a 4:1 Static Mux can be configured per EPWM using

CONTROLSS_CTRL.EPWM_STATICXBAR_SEL0 & CONTROLSS_CTRL.EPWM_STATICXBAR_SEL1 register.

ADC0, ADC1, ADC2, ADC3, ADC4 and ADC5 are different interconnect per initiator (R5FSS0-0_AHB,R5FSS0-1_AHB,R5FSS1-0_AHB,R5FSS1-1_AHB,CORE VBUSP(Port0),CORE VBUSP(Port1)). The target ports are based on number of ADCs in the design. Each initiator can independently access any ADC register without any arbitration.

3.8 Memory Protection Units (MPU)

This section describes the Memory Protection Units (MPU) for the device.

3.8.1 MPU Overview

The Memory Protection Unit (MPU) protects data and configuration spaces by managing the access to these memories. It allows multiple ranges of protection with different access permissions to be defined. Each range can be made secure by limiting the access only to secure system masters. Access can also be granted or not to individual system masters based on their privilege ID or access types. The MPU can also record a detected fault or invalid access and notify the system through an interrupt.

The MPU has the following features:

- Supports multiple programmable address ranges
- Supports secure and debug access privileges
- Supports read, write, and execute access privileges
- Supports privilege ID associations with the programmable address ranges
- Generates an interrupt when there is addressing or protection violation and saves violating transfer parameters
- Supports L1/L2 cache accesses
- Supports protection of its own registers.

3.8.2 MPU Functional Description

3.8.2.1 Functional Block Diagram

Figure 3-4 shows a block diagram of the MPU. An access to a protected memory must pass through the MPU. During an access, the MPU checks the address on the input data bus against programmable ranges. If allowed, the transfer is passed unmodified to the output data bus. If the transfer fails the protection check then the MPU does not pass the transfer to the output bus. To prevent a hang it services the transfer internally back to the input bus returning the fault status to the requestor and generates an interrupt about the fault. For read accesses the MPU returns zeros and fault status. For write accesses it receives all data and returns fault status.

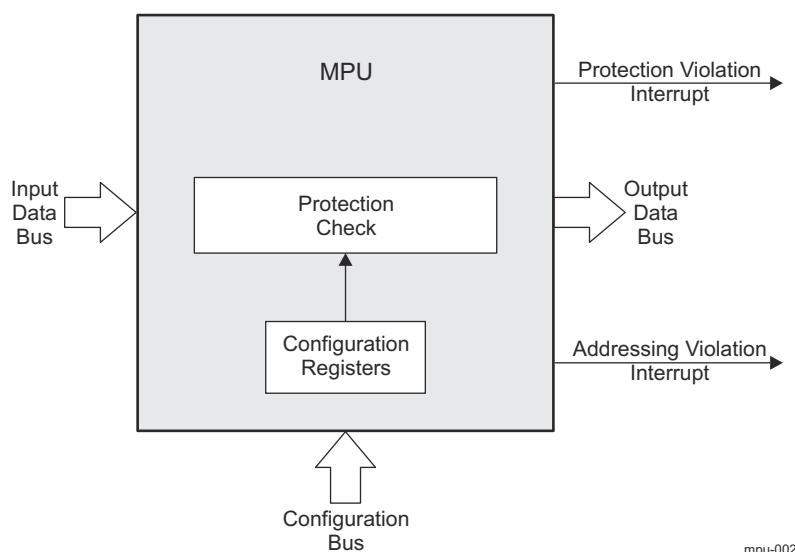

Figure 3-4. MPU Block Diagram

3.8.2.2 Privilege Levels

The privilege level of a memory access determines what level of permissions the originator of the memory access might have. Two privilege levels are supported: supervisor and user.

Supervisor level is generally granted access to peripheral registers and the MPU configuration registers. User level is generally confined to the memory spaces that the OS specifically designates for its use.

Processor instruction and data accesses have a privilege level associated with them. The privilege level is inherited from the code running on the corresponding processor.

3.8.2.3 Memory Protection Ranges

The MPU divides its assigned memory into address ranges. Each MPU on CORE VBUSM targets can support up to 8 programmable address ranges. Each MPU on the CORE VBUSP initiators can support up to 16 programmable address ranges. The programmable address range allows software to program the start and end addresses.

Each programmable address range has the following set of registers:

- MPU_PROGx_MPSAR - specifies the start address of region *x*
- MPU_PROGx_MPEAR - specifies the end address of region *x*
- MPU_PROGx_MPPAR - specifies the permissions of region *x*

It is allowed to configure ranges such that they overlap each other. In this case all overlapped ranges must allow the access, otherwise the access is not allowed. The final permissions given to the access are the lowest among all types of permissions associated with these overlapped ranges.

Note

The amount of physical memory used by a particular design may be less than the maximum amount of memory supported by the device. In such cases, the not used memory range must be protected in order to prevent unintended (aliased) accesses to the memory in use. One of the programmable address ranges could be used to detect accesses to this not used memory range.

3.8.2.4 Permissions of Programmable Address Range

The fields of the MPU_PROGx_MPPAR register can be split into 3 groups:

- **Allowed privilege IDs** - bits MPU_PROGx_MPPAR[25-9]
- **Security** - bits MPU_PROGx_MPPAR[7-6]
- **Access types** - bits MPU_PROGx_MPPAR[5-0]

Allowed privilege IDs

With almost each master on the device there is an associated privilege ID (called also PrivID). This PrivID identifies the master for privilege purposes and accompanies all memory accesses made on behalf of that master. That is, when a master triggers a memory access command, the PrivID is carried alongside the command.

Note

There is no PrivID for the EDMA Controller.

Each AID bit from the MPU_PROGx_MPPAR[25-9] field specifies whether the master accessing the given address range and having PrivID corresponding to the AID bit is checked for access permissions or not. If AID = 1 the access permissions specified via MPU_PROGx_MPPAR[7-6] and MPU_PROGx_MPPAR[5-0] bits are checked. If AID = 0 these permissions are not checked.

Security

The MPU_PROGx_MPPAR[7] NS and MPU_PROGx_MPPAR[6] EMU bits specify 3 valid protection levels for region x as described in [Table 3-4](#). The term *debug access* refers to an access initiated through the emulation port of the device.

Table 3-4. Protection Levels

NS	EMU	Description
0	0	Region x is secure without debug: Only secure accesses are allowed. Debug accesses are not allowed. Non-secure accesses are also not allowed
0	1	Region x is secure with debug: Only secure and debug accesses are allowed. Non-secure accesses are not allowed
1	-	Region x is non-secure: All accesses (non-secure, secure and debug) are allowed.

Access types

The memory protection model defines three fundamental functional access types: read, write, and execute. Read and write refer to data accesses originating from the corresponding processor or master peripheral. Execute refers to accesses associated with an instruction fetch. The memory protection model allows to control the read, write, and execute permissions independently for both privilege levels - supervisor and user. This results in 6 permission bits shown in [Table 3-5](#).

Table 3-5. Request Type Access Controls

Bit	Description
MPU_PROGx_MPPAR[5] SR	Supervisor may read
MPU_PROGx_MPPAR[4] SW	Supervisor may write
MPU_PROGx_MPPAR[3] SX	Supervisor may execute
MPU_PROGx_MPPAR[2] UR	User may read
MPU_PROGx_MPPAR[1] UW	User may write
MPU_PROGx_MPPAR[0] UX	User may execute

For each bit, a value of 1 permits the access type, and 0 denies it. So, setting the MPU_PROGx_MPPAR[0] UX bit to 1 means that a master in user mode may execute from region x specified by the MPU_PROGx_MPPAR and MPU_PROGx_MPPAR registers.

The MPU allows the programmer to specify each of these 6 bits separately. Thus 64 different combinations are possible but programs might not use all of them.

3.8.2.5 Protection Check

During a memory access, the MPU checks if the address range of the input transfer overlaps one of the address ranges defined via registers MPU_PROGx_MPSAR and MPU_PROGx_MPEAR. When the address of the input transfer is within a range the transfer parameters are checked against the address range permissions specified by register MPU_PROGx_MPPAR. The MPU first checks the PrivID against the AID settings. If the corresponding AID bit is 0, then the access permissions of this PrivID are not checked and the access is allowed or not depending on the value of the MPU_CONFIG[0] ASSUME_ALLOWED bit. If the AID bit is 1, then to detect an allowed access the transfer secure and debug parameters are checked against the MPU_PROGx_MPPAR[7] NS and MPU_PROGx_MPPAR[6] EMU values as described in [Table 3-4](#).

For non-debug accesses the read, write, and execute permissions are also checked. There is a set of permissions for supervisor mode and another for user mode. For supervisor mode accesses, the MPU_PROGx_MPPAR[5] SR, MPU_PROGx_MPPAR[4] SW, and MPU_PROGx_MPPAR[3] SX bits are checked. For user mode accesses the MPU_PROGx_MPPAR[2] UR, MPU_PROGx_MPPAR[1] UW, and MPU_PROGx_MPPAR[0] UX bits are checked.

If the address of the input transfer does not match any address range defined via registers MPU_PROGx_MPSAR and MPU_PROGx_MPEAR, then the transfer is allowed or not depending on the value of the MPU_CONFIG[0] ASSUME_ALLOWED bit. If ASSUME_ALLOWED = 0 the transfer is not allowed. If ASSUME_ALLOWED = 1 the transfer is allowed.

In case that a transfer spans multiple address ranges, all overlapped ranges must allow the access, otherwise the access is not allowed. The final permissions given to the access are the lowest among all types of permissions associated with these overlapped ranges. Therefore, if a transfer matches two ranges, one that is RW and one that is RX, then the final permission is just R.

The MPU has a special mechanism for handling DSP L1/L2 cache controller read accesses. See for more details.

3.8.2.6 Protection of the MPU Configuration Registers

Accesses to the MPU_PROGx_MPSAR, MPU_PROGx_MPEAR and MPU_PROGx_MPPAR registers are also protected. All non-debug writes must be by a supervisor master. If the MPU_PROGx_MPPAR[7] NS bit is 0, then all writes must be by a secure master. In addition, the NS bit can be modified only by a secure master. A register write with invalid permissions results in protection fault and interrupt generation.

A debug write is only allowed if NS = 1 or the EMU = 1 regardless of the secure or privilege attributes. Neither faults are recorded nor interrupts are generated for debug accesses.

3.8.2.7 MPU Interrupt Requests

Each MPU module has one interrupt request, the MPU_x_INT (x = 0 to 16), associated with the following registers:

- MPU_IRAWSTAT - interrupt raw status register
- MPU_IENSTAT - interrupt status register
- MPU_IENSET - interrupt enable register
- MPU_IENCLR - interrupt disable register

For the interrupt behavior of each MPU module the following applies:

- The MPU module asserts its interrupt line MPU_x_INT (x = 0 to 16) only if the interrupts are enabled by setting to 1h the corresponding bits in the MPU_IENSET register. These interrupts can be disabled by setting to 1h the corresponding bits in the MPU_IENCLR register.
- After an interrupt has been serviced, software must clear the corresponding status flag. This is done by setting to 1h the corresponding bit in the MPU_IENSTAT register which also clears the corresponding bit in the MPU_IRAWSTAT register. The status flags in the MPU_IRAWSTAT register are set even if the corresponding interrupt is disabled unlike those in the MPU_IENSTAT register, which are set only if the corresponding interrupt is enabled.
- An interrupt is also generated by the MPU, if certain bit in the MPU_IRAWSTAT register is set to 1h and the corresponding interrupt is enabled through the MPU_IENSET register. This feature is useful during user software debugging. In addition, even if interrupts are not enabled the corresponding raw flag in the MPU_IRAWSTAT register is set to 1h when an IRQ condition occurs.
- Even if interrupts are not enabled, a status bit in the MPU_IRAWSTAT register can also be cleared by setting to 1h the corresponding bit in the MPU_IENSTAT register.

Table 3-6 lists the interrupt events which can assert the MPU_x_INT interrupt line.

Table 3-6. MPU Events

Event Flag	Event Mask	Description
MPU_IRAWSTAT[1] ADDR_ERR MPU_IENSTAT[1] ENABLED_ADDR_ERR	MPU_IENSET[1] ADDR_ERR_EN MPU_IENCLR[1] ADDR_ERR_EN_CLR	Addressing violation interrupt. Occurs when an access to a non-existent location in the MPU configuration register space is performed.
MPU_IRAWSTAT[0] PROT_ERR MPU_IENSTAT[0] ENABLED_PROT_ERR	MPU_IENSET[0] PROT_ERR_EN MPU_IENCLR[0] PROT_ERR_EN_CLR	This interrupt occurs in case of protection violation of the programmable regions or of the MPU configuration register space.

When addressing violation or protection violation occurs, the error associated details are captured in the MPU_FLTADDR and MPU_FLTSTAT registers. MPU_FLTADDR contains the address of the first fault access and MPU_FLTSTAT contains status attributes associated with the first fault access. To clear the current fault the MPU_FLTCLR[0] CLEAR bit must be set to 1h. If not cleared, other faults are not recorded as the MPU stores fault information for only one fault. The MPU neither records another fault nor generates another interrupt until the existing fault has been cleared. This means that all other faults are ignored. For debug accesses neither faults are recorded nor interrupts are generated.

3.8.2.8 Emulation Considerations

Memory is protected against emulation accesses by the MPU. Emulator access to memory is controlled through the MPU_PROGx_MPPAR[7] NS and MPU_PROGx_MPPAR[6] EMU bits. See Table 3-4 for more details.

The MPU also protects its registers MPU_PROGx_MPSAR, MPU_PROGx_MPEAR and MPU_PROGx_MPPAR against emulation accesses. See Section 3.8.2.6 for more details.

The device contains 18 MPUs. [Memory protected regions](#) lists these MPUs and also the regions protected by each MPU. The start address and length for the system interconnect MPU regions must be aligned to 1kB.

3.8.3 MPU Memory Regions

MPU	MPU Configuration Address	Address Range
MPU_L2OCRAM_BANK0	0x4002 0000	OCSRAM BANK 0: 0x7000_0000 to 0x7007_FFFF
MPU_L2OCRAM_BANK1	0x4004 0000	OCSRAM BANK 1: 0x7007_0000 to 0x700F_FFFF
MPU_L2OCRAM_BANK2	0x4006 0000	OCSRAM BANK 2: 0x7010_0000 to 0x7017_FFFF
MPU_L2OCRAM_BANK3	0x4008 0000	OCSRAM BANK 3: 0x7018_0000 to 0x701F_FFFF
MPU_R5SS0_CORE0_AXIS	0x400A 0000	R5FSS0-0's ATCM, BTCM, icache and dcache
MPU_R5SS0_CORE1_AXIS	0x400C 0000	R5FSS0-1's ATCM, BTCM, icache and dcache
MPU_R5SS1_CORE0_AXIS	0x400E 0000	R5FSS1-0's ATCM, BTCM, icache and dcache
MPU_R5SS1_CORE1_AXIS	0x4010 0000	R5FSS1-1's ATCM, BTCM, icache and dcache
MPU_HSM_DTHE	0x4012 0000	All the end points inside DTHE
MPU_MBOX_SRAM	0x4014 0000	SRAM for MAILBOX
MPU_QSPI0	0x4016 0000	QSPI Data Region
MPU_SCRM2SCRPO	0x4018 0000	All end points at address range: 0x5000_0000 to 0x5FFF_FFFF
MPU_SCRM2SCRPI	0x401A 0000	All end points at address range: 0x5000_0000 to 0x5FFF_FFFF
MPU_R5SS0_CORE0_AHB	0x401C 0000	Only transactions from R5FSS0-0 (core 0) access its peripheral regions at address range: 0x5000_0000 to 0x5FFF_FFFF
MPU_R5SS0_CORE1_AHB	0x401E 0000	Only transactions from R5FSS0-1 (core 1) access its peripheral regions at address range: 0x5000_0000 to 0x5FFF_FFFF
MPU_R5SS1_CORE0_AHB	0x4020 0000	Only transactions from R5FSS1-0 (core 2) access its peripheral regions at address range: 0x5000_0000 to 0x5FFF_FFFF
MPU_R5SS1_CORE1_AHB	0x4022 0000	Only transactions from R5FSS1-1 (core 3) access its peripheral regions at address range: 0x5000_0000 to 0x5FFF_FFFF
MPU_HSM	0x4024 0000	All end points inside HSM

3.8.4 Initiator IDs

Table 3-7 shows the unique Initiator ID assigned to each Initiator on the device. Any values not listed below are **not assigned** and should be considered as reserved IDs.

Note

Initiator IDs are used to determine allowed connections between Initiators and Targets. They are also used to determine if the Initiator performed a faulty transfer.

Table 3-7. Initiator IDs

Initiator ID	Initiator
0	R5FSS0-0_AHB
1	R5FSS0-1_AHB
2	R5FSS1-0_AHB
3	R5FSS1-1_AHB
4	DEBUGSS
5	HSM
6	ICSSM_PRU0
7	ICSSM_PRU1
8	SoC_TC0_R
9	SoC_TC0_W
10	SoC_TC1_R
11	SoC_TC1_W
12	HSM_TC0_R
13	HSM_TC0_W
14	HSM_TC1_R
15	HSM_TC1_W
16	R5FSS0-0_R
17	R5FSS0-0_W
18	R5FSS0-1_R
19	R5FSS0-1_W
20	R5FSS1-0_R
21	R5FSS1-0_W
22	R5FSS1-1_R
23	R5FSS1-1_W
28-29	From CPSW Interconnect

3.8.5 PrivIDs

Table 3-8 shows the PrivID assigned to each Initiator on the device.

Note

PrivIDs are used by the MPUs to protect a given memory range against undesirable accesses.

Initiator IDs are unique to each Initiator unlike PrivIDs which are shared among different Initiators.

Table 3-8. PrivIDs

PrivID (decimal)	Initiator
1	HSM
2-3	Not Assigned
4	R5FSS0-0_r
4	R5FSS0-0_w
4	R5FSS0-0_AHB
5	R5FSS0-1_r
5	R5FSS0-1_w
5	R5FSS0-1_AHB
6	R5FSS1-0_r
6	R5FSS1-0_w
6	R5FSS1-0_AHB
7	R5FSS1-1_r
7	R5FSS1-1_w
7	R5FSS1-1_AHB
8	Not Assigned
9	ICSSM_PRU0
9	ICSSM_PRU1
10	From CPSW Interconnect
11-15	Not Assigned



This chapter describes the integration details for each module in the device, including information about clocks, resets, interrupts, DMA events and other hardware requests.

4.1 ADC Integration.....	56
4.2 DAC Integration.....	57
4.3 ECAP Integration.....	58
4.4 EPWM Integration.....	60
4.5 EQEP Integration.....	62
4.6 FSI Integration.....	63
4.7 SDFM Integration.....	64
4.8 SOC_TIMESYNC_XBAR0 Integration.....	66
4.9 SOC_TIMESYNC_XBAR1 Integration.....	68
GPIO Integration.....	71
4.10 I2C Integration.....	75
4.11 SPI Integration.....	78
4.12 UART Integration.....	84
4.13 CPSW3G Integration.....	90
4.14 MMCSD Integration.....	93
4.15 QSPI Integration (AM263x).....	96
4.16 MCAN Integration.....	98
4.17 LIN Integration.....	0
4.17 RTI Integration.....	113
4.18 WWDT Integration.....	119
4.19 DCC Integration.....	123
4.20 ESM Integration.....	128
4.21 ECC Aggregator Integration.....	130
4.22 MCRC Integration.....	132

4.1 ADC Integration

There are 5x Analog-to-Digital Converter (ADC) modules integrated in the device. The diagram below provides a visual representation of the device integration details.

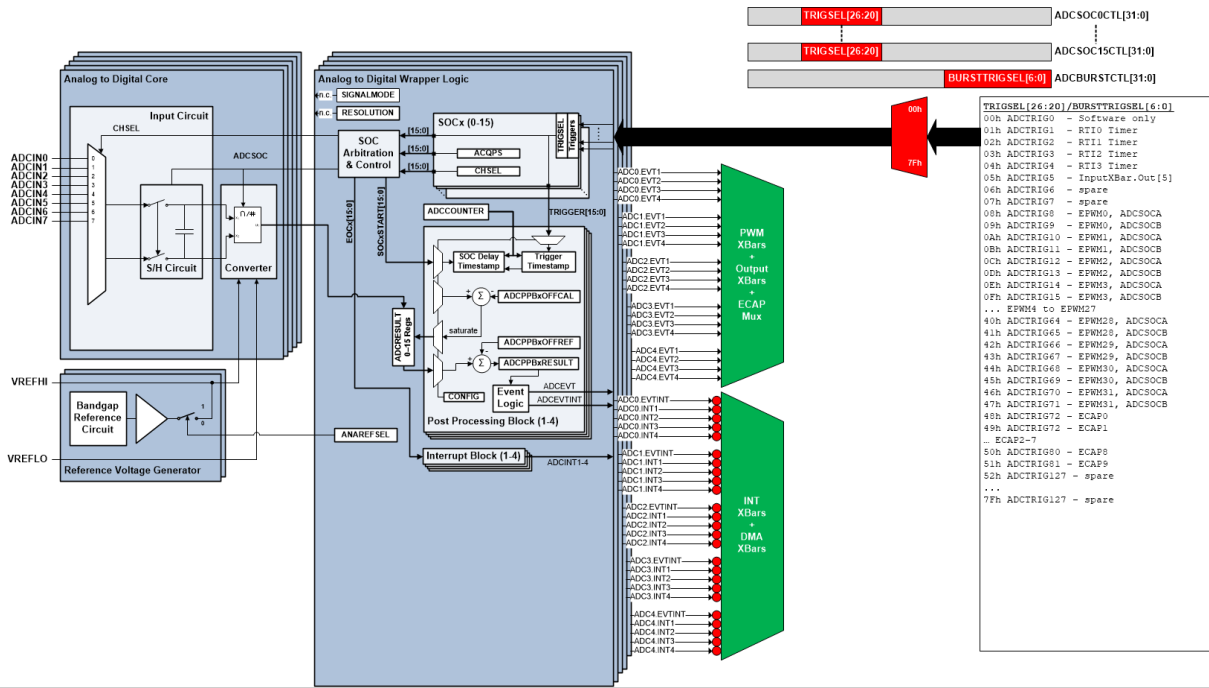

Figure 4-1. ADC Integration Diagram

ADVANCE INFORMATION

4.2 DAC Integration

There is 1x DAC module integrated in the device. The diagram below provides a visual representation of the device integration details.

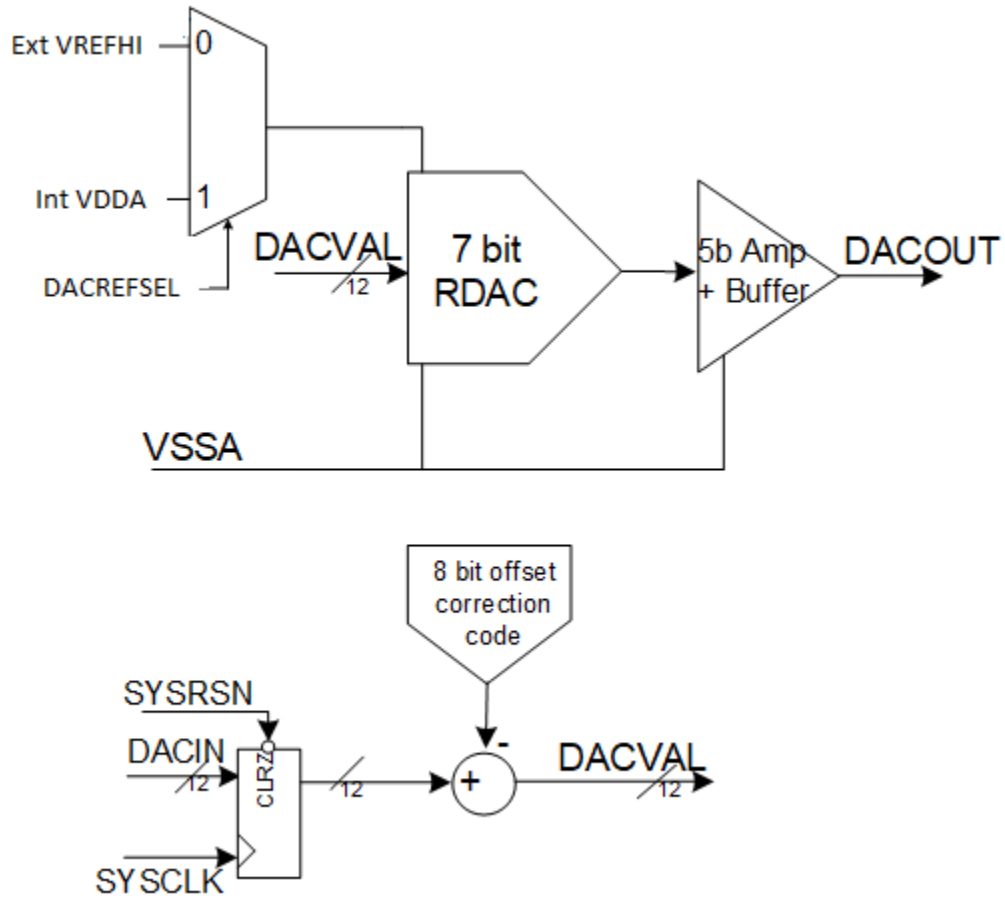
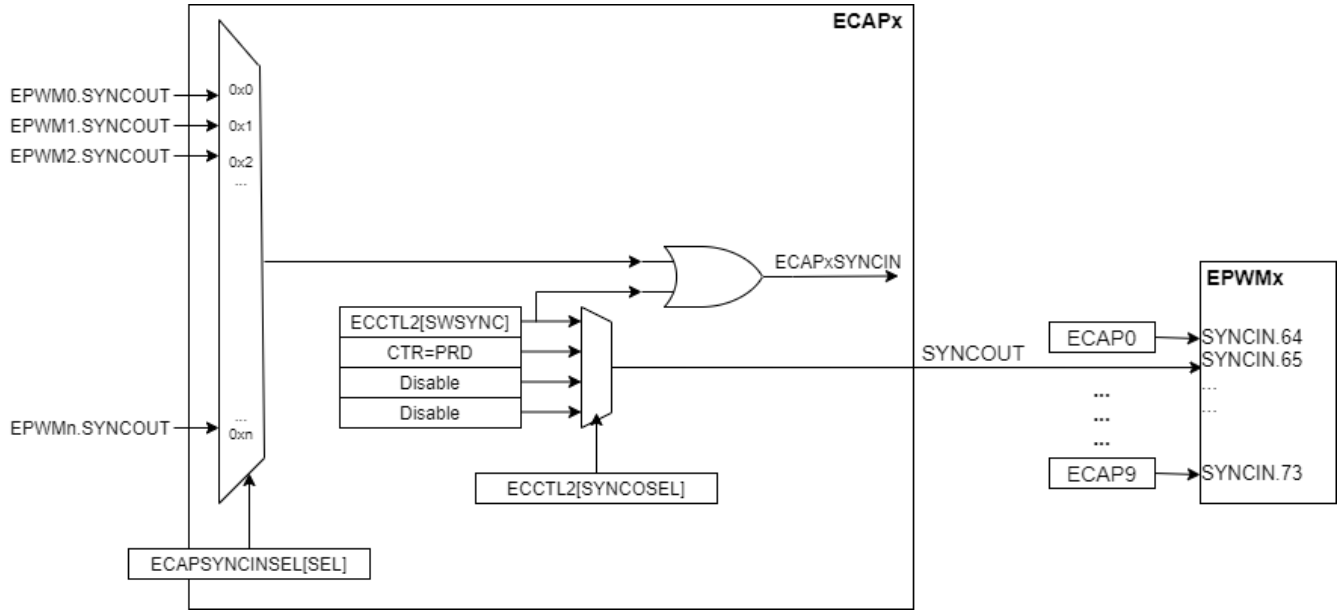

Figure 4-2. DAC Integration Diagram

4.3 ECAP Integration

There are 10x ECAP modules integrated in the device. The diagram below provides a visual representation of the device integration details.



ADVANCE INFORMATION

4.4 EPWM Integration

There are 32x EPWM modules integrated in the device. The diagram below provides a visual representation of the device integration details.

4.6 FSI Integration

There are 4x FSI modules integrated in the CONTROLSS. The diagram below provides a visual representation of the device integration details.

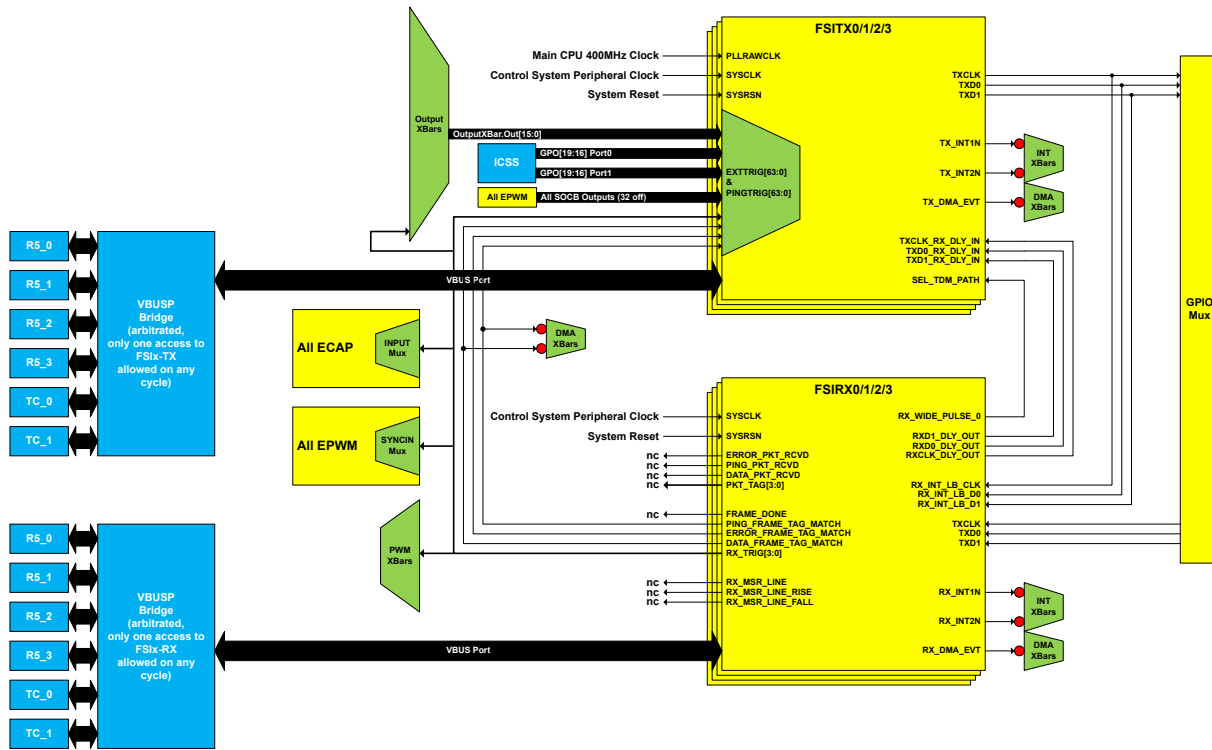

Figure 4-6. FSI Integration Diagram

ADVANCE INFORMATION

4.7 SDFM Integration

There are 4x SDFM modules integrated in the CONTROLSS. The diagram below provides a visual representation of the device integration details.

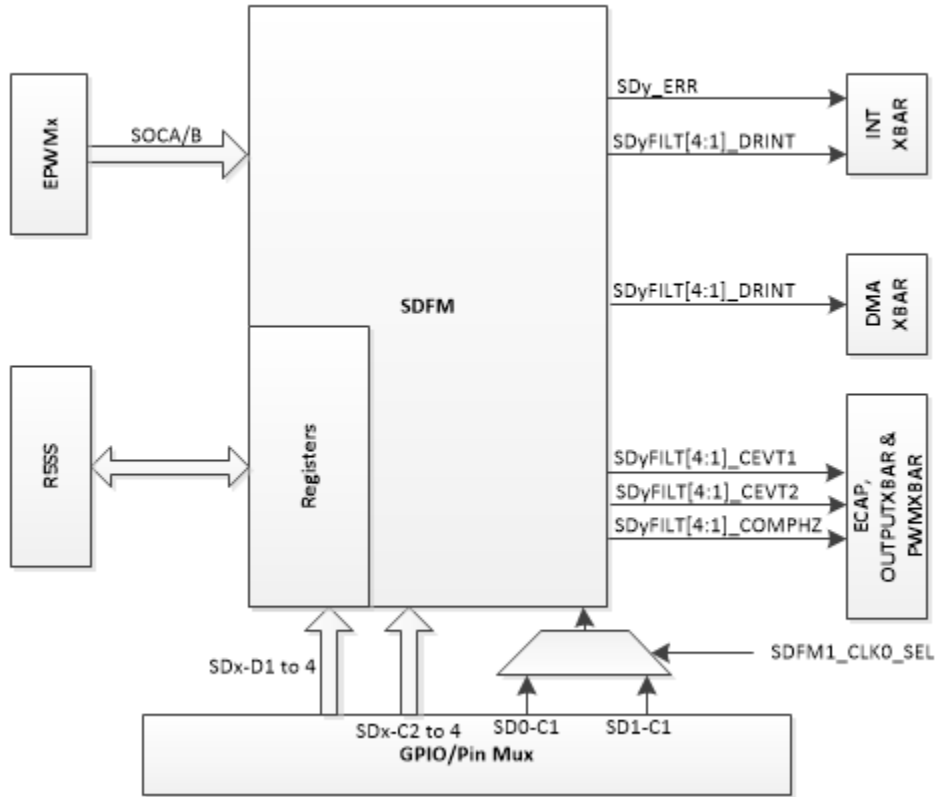
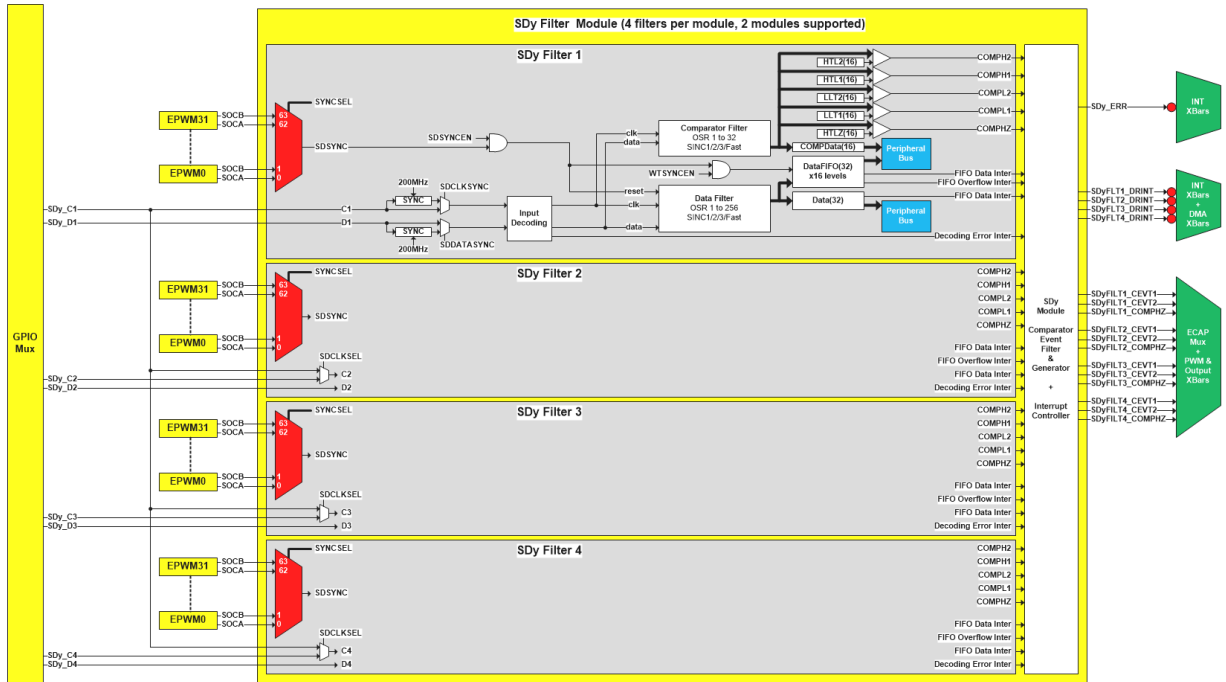

Figure 4-7. SDFM Integration Diagram (Simple)

ADVANCE INFORMATION



ADVANCE INFORMATION

4.8 SOC_TIMESYNC_XBAR0 Integration

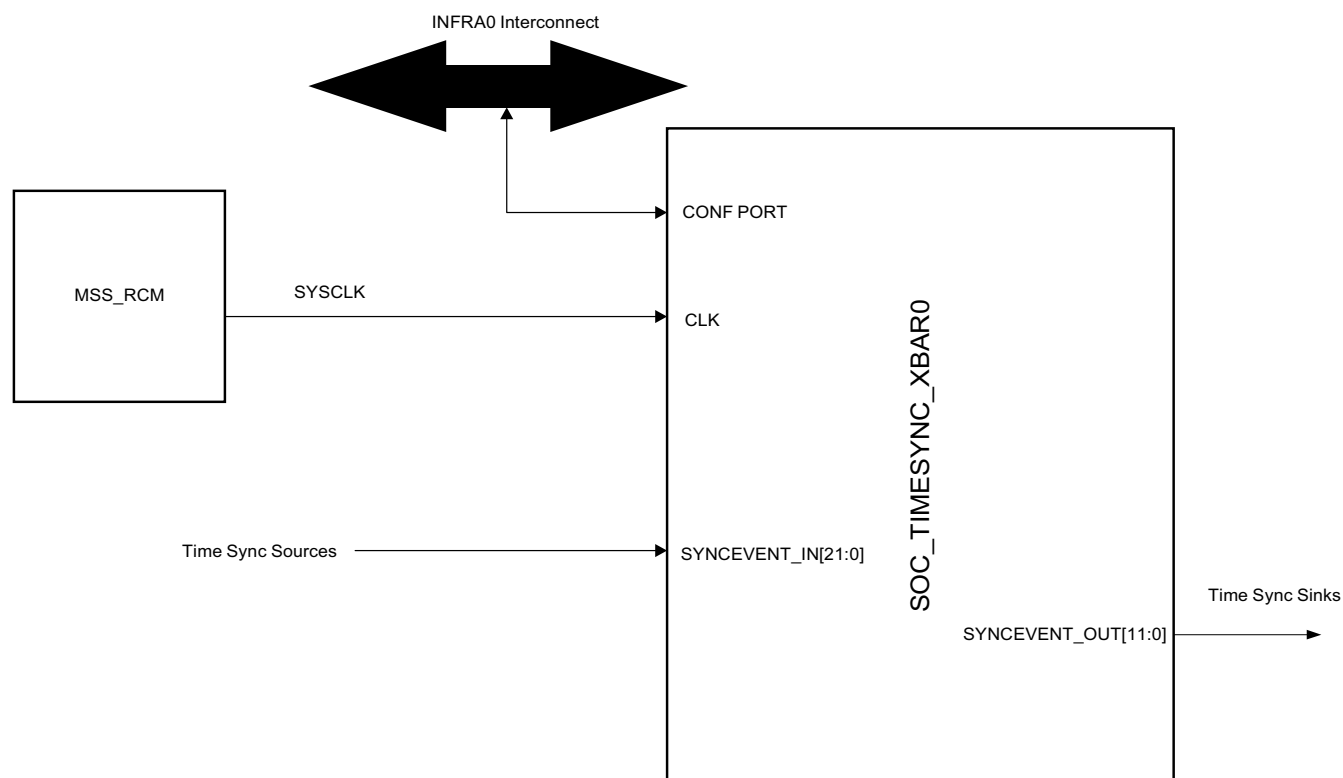

Figure 4-9. SOC_TIMESYNC_XBAR0 Integration

Table 4-1. SOC_TIMESYNC_XBAR0 Device Integration

Module Instance	Device Allocation	SoC Interconnect
SOC_TIMESYNC_XBAR0	✓	VBUSP INFRA0 Interconnect

Table 4-2. SOC_TIMESYNC_XBAR0 Clocks

Module Instance	Module Clock Input	Source Clock Signal	Source	Default Freq	Description
SOC_TIMESYNC_XBAR0	CLK	SYSCLK	MSS_RCM	200 MHz	SOC_TIMESYNC_XBAR0 Functional and Interface clock

Table 4-3. SOC_TIMESYNC_XBAR0 Resets

Module Instance	Module Reset Input	Source Reset Signal	Source	Description
SOC_TIMESYNC_XBAR0	RST	SYS_RST	RCM + Warm Reset Sources	SOC_TIMESYNC_XBAR0 Reset

Table 4-4. SOC_TIMESYNC_XBAR0 Time Sync Output Events

Module Instance	Module Sync Output	Destination Sync Signal	Destination	Type	Description
SOC_TIMESYNC_XBAR0	SYNCEVENT_OUT0	EPWMx_SYNC_IN58	EPWMx	Edge	Selectable sync event 0
	SYNCEVENT_OUT1	EPWMx_SYNC_IN59	EPWMx		Selectable sync event 1
	SYNCEVENT_OUT2	CAPEVT0	RTI0,WDT0		Selectable sync event 2
	SYNCEVENT_OUT3	CAPEVT1	RTI0,WDT0		Selectable sync event 3
	SYNCEVENT_OUT4	CAPEVT0	RTI1,WDT1		Selectable sync event 4
	SYNCEVENT_OUT5	CAPEVT1	RTI1,WDT1		Selectable sync event 5
	SYNCEVENT_OUT6	CAPEVT0	RTI2,WDT2		Selectable sync event 6

Module Instance	Module Sync Input	TimeSync Event Sources
SOC_TIMESYNC_XBAR0	SYNCEVENT_IN[21:0]	See SOC_TIMESYNC_XBAR0 Event Map table for time sync event mapping.

4.9 SOC_TIMESYNC_XBAR1 Integration

ADVANCE INFORMATION

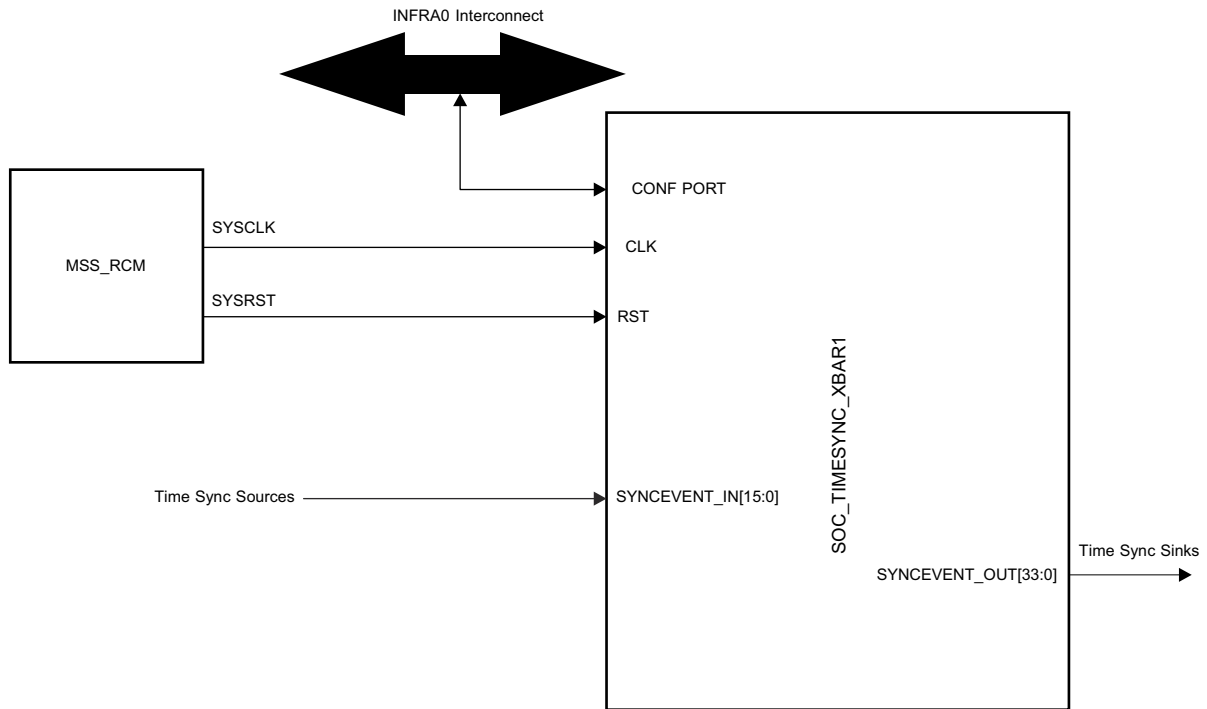

Figure 4-10. SOC_TIMESYNC_XBAR1 Integration

Table 4-5. SOC_TIMESYNC_XBAR1 Device Integration

Module Instance	Device Allocation	SoC Interconnect
SOC_TIMESYNC_XBAR1	✓	VBUSP INFRA0 Interconnect

Table 4-6. SOC_TIMESYNC_XBAR1 Clocks

Module Instance	Module Clock Input	Source Clock Signal	Source	Default Freq	Description
SOC_TIMESYNC_XBAR1	CLK	SYSCLK	MSS_RCM	200 MHz	SOC_TIMESYNC_XBAR1 Functional and Interface clock

Table 4-7. SOC_TIMESYNC_XBAR1 Resets

Module Instance	Module Reset Input	Source Reset Signal	Source	Description
SOC_TIMESYNC_XBAR1	RST	SYS_RST	RCM + Warm Reset Sources	SOC_TIMESYNC_XBAR1 Reset

Table 4-8. SOC_TIMESYNC_XBAR1 Time Sync Output Events

ModuleTime Sync Events (Outputs)					
Module Instance	Module Sync Output	Destination Sync Signal	Destination	Type	Description
SOC_TIMESYNC_XBAR1	SYNCEVENT_OUT0	EDMA_TRIGG ERXBAR_IN11 1	EDMA_TRIGG ERXBAR	Edge	Selectablesync event 0
	SYNCEVENT_OUT1	EDMA_TRIGG ERXBAR_IN11 2	EDMA_TRIGG ERXBAR		Selectablesync event 1
	SYNCEVENT_OUT2	R5SS0_CORE 0_INTR138	R5SS0_CORE 0_VIM		Selectablesync event 2
	SYNCEVENT_OUT3	R5SS0_CORE 0_INTR139	R5SS0_CORE 0_VIM		Selectablesync event 3
	SYNCEVENT_OUT4	R5SS0_CORE 0_INTR140	R5SS0_CORE 0_VIM		Selectablesync event 4
	SYNCEVENT_OUT5	R5SS0_CORE 0_INTR141	R5SS0_CORE 0_VIM		Selectablesync event 5
	SYNCEVENT_OUT6	R5SS0_CORE 1_INTR138	R5SS0_CORE 1_VIM		Selectablesync event 6
	SYNCEVENT_OUT7	R5SS0_CORE 1_INTR139	R5SS0_CORE 1_VIM		Selectablesync event 7
	SYNCEVENT_OUT8	R5SS0_CORE 1_INTR140	R5SS0_CORE 1_VIM		Selectablesync event 8
	SYNCEVENT_OUT9	R5SS0_CORE 1_INTR141	R5SS0_CORE 1_VIM		Selectablesync event 9
	SYNCEVENT_OUT10	ICSSM0_EDC_LATCH0_IN	PRU_ICSSM0		Selectablesync event 10
	SYNCEVENT_OUT11	ICSSM0_EDC_LATCH1_IN	PRU_ICSSM0		Selectablesync event 11
	SYNCEVENT_OUT12	ICSSM0_IEP_CAP_INT R0	PRU_ICSSM0		Selectablesync event 12
	SYNCEVENT_OUT13	ICSSM0_IEP_CAP_INT R1	PRU_ICSSM0		Selectablesync event 13
	SYNCEVENT_OUT14	ICSSM0_IEP_CAP_INT R2	PRU_ICSSM0		Selectablesync event 14
	SYNCEVENT_OUT15	ICSSM0_IEP_CAP_INT R3	PRU_ICSSM0		Selectablesync event 15
	SYNCEVENT_OUT16	ICSSM0_IEP_CAP_INT R4	PRU_ICSSM0		Selectablesync event 16
	SYNCEVENT_OUT17	ICSSM0_IEP_CAP_INT R5	PRU_ICSSM0		Selectablesync event 17
	SYNCEVENT_OUT18	CPTS_HW1_T S_PUSH	CPSW0_CPTS		Selectablesync event 18
	SYNCEVENT_OUT19	CPTS_HW2_T S_PUSH	CPSW0_CPTS		Selectablesync event 19
	SYNCEVENT_OUT20	CPTS_HW3_T S_PUSH	CPSW0_CPTS		Selectablesync event 20
	SYNCEVENT_OUT21	CPTS_HW4_T S_PUSH	CPSW0_CPTS		Selectablesync event 21
	SYNCEVENT_OUT22	CPTS_HW5_T S_PUSH	CPSW0_CPTS		Selectablesync event 22
	SYNCEVENT_OUT23	CPTS_HW6_T S_PUSH	CPSW0_CPTS		Selectablesync event 23
	SYNCEVENT_OUT24	CPTS_HW7_T S_PUSH	CPSW0_CPTS		Selectablesync event 24
	SYNCEVENT_OUT25	CPTS_HW8_T S_PUSH	CPSW0_CPTS		Selectablesync event 25
	SYNCEVENT_OUT26	R5SS1_CORE 0_INTR138	R5SS1_CORE 0_VIM		Selectablesync event 26
SYNCEVENT_OUT27	R5SS1_CORE 0_INTR139	R5SS1_CORE 0_VIM	Selectablesync event 27		

Module Instance	Module Sync Input	TimeSync Event Sources
SOC_TIMESYNC_XBAR1	SYNCEVENT_IN[15:0]	See SOC_TIMESYNC_XBAR1 Event Map table for time sync event mapping.

GPIO Integration

There are 4x GPIO modules integrated in the device. The diagram below provides a visual representation of the device integration details.

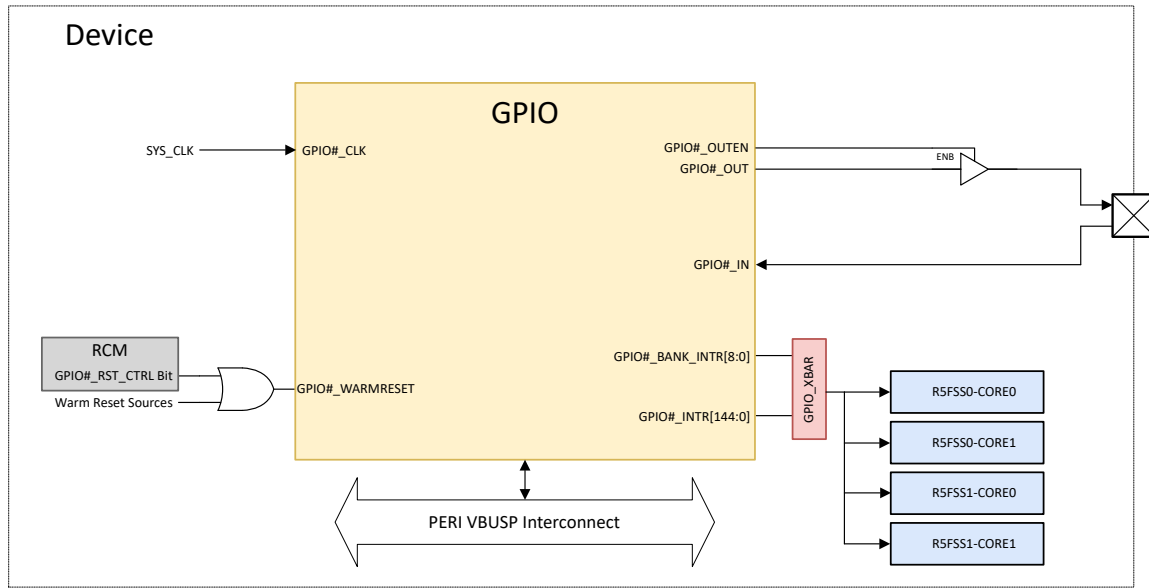

ADVANCE INFORMATION

Figure 4-11. GPIO Integration Diagram

Note

There is a designated GPIO module per R5FSS core. Each R5FSS core has access to all GPI signals. The GPO signals can be assigned to a specific R5FSS core by configuring the `MSS_IOMUX.PAD_CFG_REG.GPIO_SEL[17:16]` of the associated IOMUX Pad Configuration register.

This diagram describes the GPIO multiplexor connectivity.

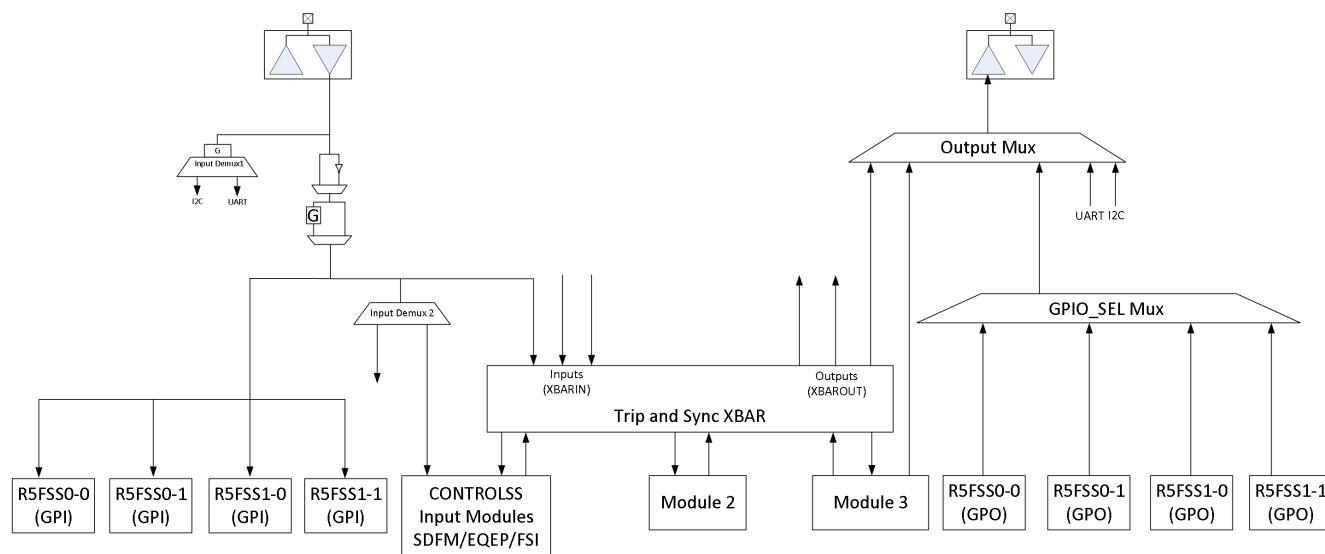

Figure 4-12. GPIO Mux Diagram

The tables below summarize the device integration details of GPIO# (where # = 0 to 4).

Table 4-9. GPIO Device Integration

This table describes the module device integration details.

Module Instance	Device Allocation	SoC Interconnect
GPIO0	✓	PERI VBUSP Interconnect
GPIO1	✓	PERI VBUSP Interconnect
GPIO2	✓	PERI VBUSP Interconnect
GPIO3	✓	PERI VBUSP Interconnect

Table 4-10. GPIO Clocks

This table describes the module clocking signals.

Module Instance	Module Clock Input	Source Clock Signal	Source	Default Freq	Description
GPIO0	GPIO0_VBUS_FICLK	SYS_CLK	PLL_CORE_CLK:HSDIV0_CLKOUT0	200 MHz	GPIO0 Functional and Interface Clock
GPIO1	GPIO1_VBUS_FICLK	SYS_CLK	PLL_CORE_CLK:HSDIV0_CLKOUT0	200 MHz	GPIO1 Functional and Interface Clock
GPIO2	GPIO2_VBUS_FICLK	SYS_CLK	PLL_CORE_CLK:HSDIV0_CLKOUT0	200 MHz	GPIO2 Functional and Interface Clock
GPIO3	GPIO3_VBUS_FICLK	SYS_CLK	PLL_CORE_CLK:HSDIV0_CLKOUT0	200 MHz	GPIO3 Functional and Interface Clock

Table 4-11. GPIO Resets

This table describes the module reset signals.

Module Instance	Module Reset Input	Source Reset Signal	Source	Description
GPIO0	GPIO0_RST	Warm Reset (MOD_G_RST)	RCM + Warm Reset Sources	GPIO0 Reset
GPIO1	GPIO1_RST	Warm Reset (MOD_G_RST)	RCM + Warm Reset Sources	GPIO1 Reset
GPIO2	GPIO2_RST	Warm Reset (MOD_G_RST)	RCM + Warm Reset Sources	GPIO2 Reset

Table 4-11. GPIO Resets (continued)

This table describes the module reset signals.

Module Instance	Module Reset Input	Source Reset Signal	Source	Description
GPIO3	GPIO3_RST	Warm Reset (MOD_G_RST)	RCM + Warm Reset Sources	GPIO3 Reset

Table 4-12. GPIO Interrupt Requests

This table describes the module interrupt requests.

Module Instance	Module Interrupt Signal	Destination Interrupt Input	Destination	Type	Description
GPIOx	GPIOx_[0:137]	Programmable via GPIO_XBAR_INTR0	GPIO_XBAR_I NTR0	Pulse	GPIOx_[0:137] interrupt request
GPIOx	GPIOx_BANK0_INT	Programmable via GPIO_XBAR_INTR0	GPIO_XBAR_I NTR0	Pulse	GPIOx BANK0 interrupt request
GPIOx	GPIOx_BANK1_INT	Programmable via GPIO_XBAR_INTR0	GPIO_XBAR_I NTR0	Pulse	GPIOx BANK1 interrupt request
GPIOx	GPIOx_BANK2_INT	Programmable via GPIO_XBAR_INTR0	GPIO_XBAR_I NTR0	Pulse	GPIOx BANK2 interrupt request
GPIOx	GPIOx_BANK3_INT	Programmable via GPIO_XBAR_INTR0	GPIO_XBAR_I NTR0	Pulse	GPIOx BANK3 interrupt request
GPIOx	GPIOx_BANK4_INT	Programmable via GPIO_XBAR_INTR0	GPIO_XBAR_I NTR0	Pulse	GPIOx BANK4 interrupt request
GPIOx	GPIOx_BANK5_INT	Programmable via GPIO_XBAR_INTR0	GPIO_XBAR_I NTR0	Pulse	GPIOx BANK5 interrupt request
GPIOx	GPIOx_BANK6_INT	Programmable via GPIO_XBAR_INTR0	GPIO_XBAR_I NTR0	Pulse	GPIOx BANK6 interrupt request
GPIOx	GPIOx_BANK7_INT	Programmable via GPIO_XBAR_INTR0	GPIO_XBAR_I NTR0	Pulse	GPIOx BANK7 interrupt request
GPIOx	GPIOx_BANK8_INT	Programmable via GPIO_XBAR_INTR0	GPIO_XBAR_I NTR0	Pulse	GPIOx BANK8 interrupt request

Note

Where x = 0 to 3

Table 4-13. GPIO DMA Requests

This table describes the module DMA requests.

Module Instance	Module DMA Event	Destination DMA Event Input	Destination	Type	Description
GPIOx	N/A	N/A	N/A	N/A	The GPIO module does not support DMA requests.

Table 4-14. GPIO Capture Event Inputs

This table describes the module capture event inputs.

Module Instance	Module Capture Event Input	Capture Event Source Signal	Source	Type	Description
GPIOx	N/A	N/A	N/A	N/A	The GPIO module does not support Capture Event Inputs

Note

For more information on the interconnects, see the *System Interconnect* chapter.

For more information on power, reset, and clock management, see the corresponding sections within the *Device Configuration* chapter.

For more information on the device interrupt controllers, see the *Interrupt Controllers* chapter.

4.10 I2C Integration

There are 4x I2C module integrated in the device. The diagram below provides a visual representation of the device integration details.

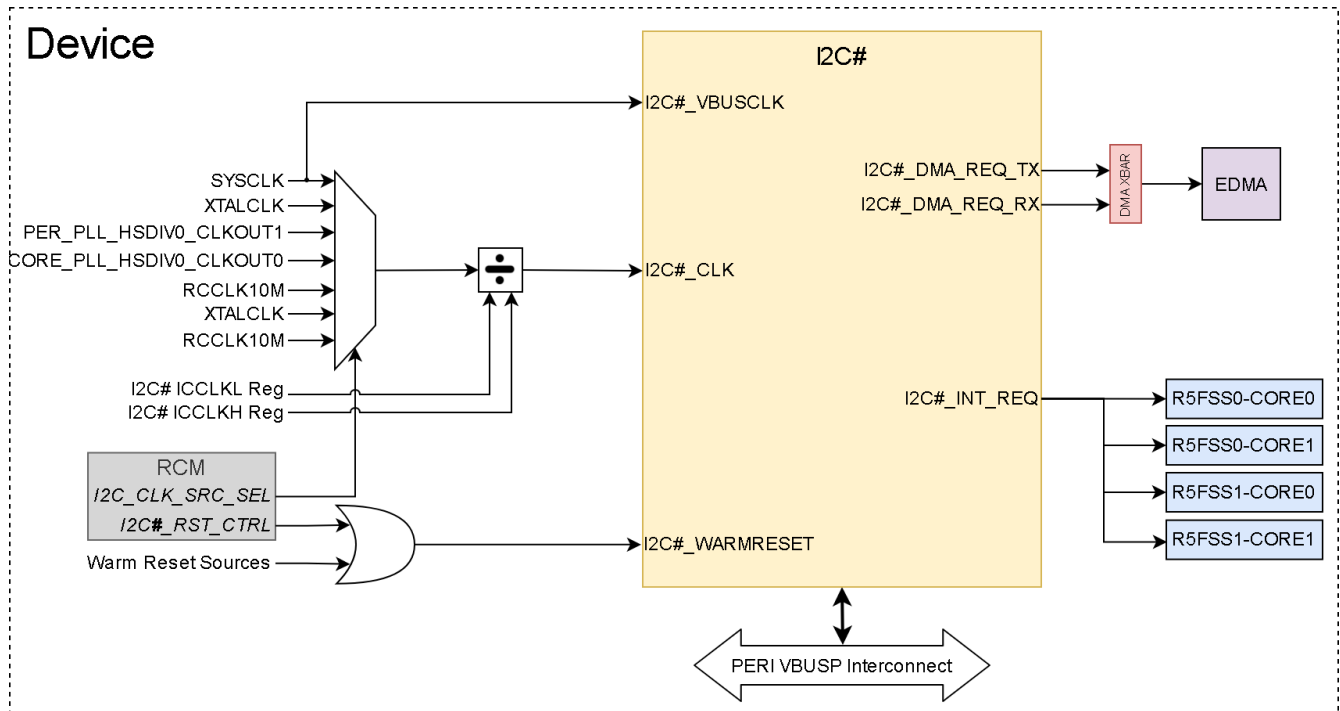

Figure 4-13. I2C Integration

The tables below summarize the device integration details of I2C# (where # = 0, 1, 2, 3).

Table 4-15. I2C Device Integration

This table describes the module device integration details.

Module Instance	Device Allocation	SoC Interconnect
I2C0	✓	PERI VBUSP Interconnect
I2C1	✓	PERI VBUSP Interconnect
I2C2	✓	PERI VBUSP Interconnect
I2C3	✓	PERI VBUSP Interconnect

Table 4-16. I2C Clocks

This table describes the module clocking signals.

Module Instance	Module Clock Input	Source Clock Signal	Source	Default Freq	Description
I2C[0:3]	I2C[0:3]_ICLK (VBUSP_CLK)	SYS_CLK	PLL_CORE_CLK: HSDIV0_CLKOUT0	200 MHz	I2C[0:3] VBUS Clock
	I2C[0:3]_FCLK (I2C_CLK)	XTALCLK	External XTAL	25 MHz	I2C[0:3] Interface Clock
		EXT_REFCLK	External Reference Clock (EXT_REFCLK)	100 MHz	
		SYS_CLK	PLL_CORE_CLK: HSDIV0_CLKOUT0	200 MHz	
		DPLL_PER_HSDIV0_CLK OUT1	PLL_PER_CLK: HSDIV0_CLKOUT1	192 MHz	
		DPLL_CORE_HSDIV0_CL KOUT0	PLL_CORE_CLK: HSDIV0_CLKOUT0	500 MHz	
		RCCLK10M	Internal 10 MHz RC Oscillator (RCCLK10M)	10 MHz	
		XTALCLK	External XTAL	25 MHz	
RCCLK10M	Internal 10 MHz RC Oscillator (RCCLK10M)	10 MHz			

Table 4-17. I2C Resets

This table describes the module reset signals.

Module Instance	Module Reset Input	Source Reset Signal	Source	Description
I2C0	I2C0_RST(VBUSP_RSTn)	Warm Reset (SYS_NPRST)	RCM + Warm Reset Sources	I2C0 Asynchronous Reset
I2C1	I2C1_RST	Warm Reset (SYS_NPRST)	RCM + Warm Reset Sources	I2C1 Asynchronous Reset
I2C2	I2C2_RST	Warm Reset (SYS_NPRST)	RCM + Warm Reset Sources	I2C2 Asynchronous Reset
I2C3	I2C3_RST	Warm Reset (SYS_NPRST)	RCM + Warm Reset Sources	I2C3 Asynchronous Reset

Table 4-18. I2C Interrupt Requests

This table describes the module interrupt requests.

Module Instance	Module Interrupt Signal	Destination Interrupt Input	Destination	Type	Description
I2C0	i2c0_int_req	i2c0_int_req	ALL R5FSS Cores ICSSM Core	Pulse	I2C0 Status Event Interrupt
I2C1	i2c1_int_req	i2c1_int_req	ALL R5FSS Cores ICSSM Core	Pulse	I2C1 Status Event Interrupt
I2C2	i2c2_int_req	i2c2_int_req	ALL R5FSS Cores ICSSM Core	Pulse	I2C2 Status Event Interrupt
I2C3	i2c3_int_req	i2c3_int_req	ALL R5FSS Cores ICSSM Core	Pulse	I2C3 Status Event Interrupt

Table 4-19. I2C DMA Requests

This table describes the module DMA requests.

Module Instance	Module DMA Event	Destination DMA Event Input	Destination	Type	Description
I2C0	I2C0_TX	i2c0_dma_req_tx	EDMA Crossbar (EDMA_XBAR)	Pulse	I2C0 DMA Transmit Request
	I2C0_RX	i2c0_dma_req_rx			I2C0 DMA Receive Request
I2C1	I2C1_TX	i2c1_dma_req_tx	EDMA Crossbar (EDMA_XBAR)	Pulse	I2C1 DMA Transmit Request
	I2C1_RX	i2c1_dma_req_rx			I2C1 DMA Receive Request
I2C2	I2C2_TX	i2c2_dma_req_tx	EDMA Crossbar (EDMA_XBAR)	Pulse	I2C2 DMA Transmit Request
	I2C2_RX	i2c2_dma_req_rx			I2C2 DMA Receive Request
I2C3	I2C3_TX	i2c3_dma_req_tx	EDMA Crossbar (EDMA_XBAR)	Pulse	I2C3 DMA Transmit Request
	I2C3_RX	i2c3_dma_req_rx			I2C3 DMA Receive Request

Note

For more information on the interconnects, see the *System Interconnect* chapter.

For more information on power, reset, and clock management, see the corresponding sections within the *Device Configuration* chapter.

For more information on the device interrupt controllers, see the *Interrupt Controllers* chapter.

4.11 SPI Integration

There are 5x SPI modules integrated in the device. The diagram below provides a visual representation of the device integration details.

ADVANCE INFORMATION

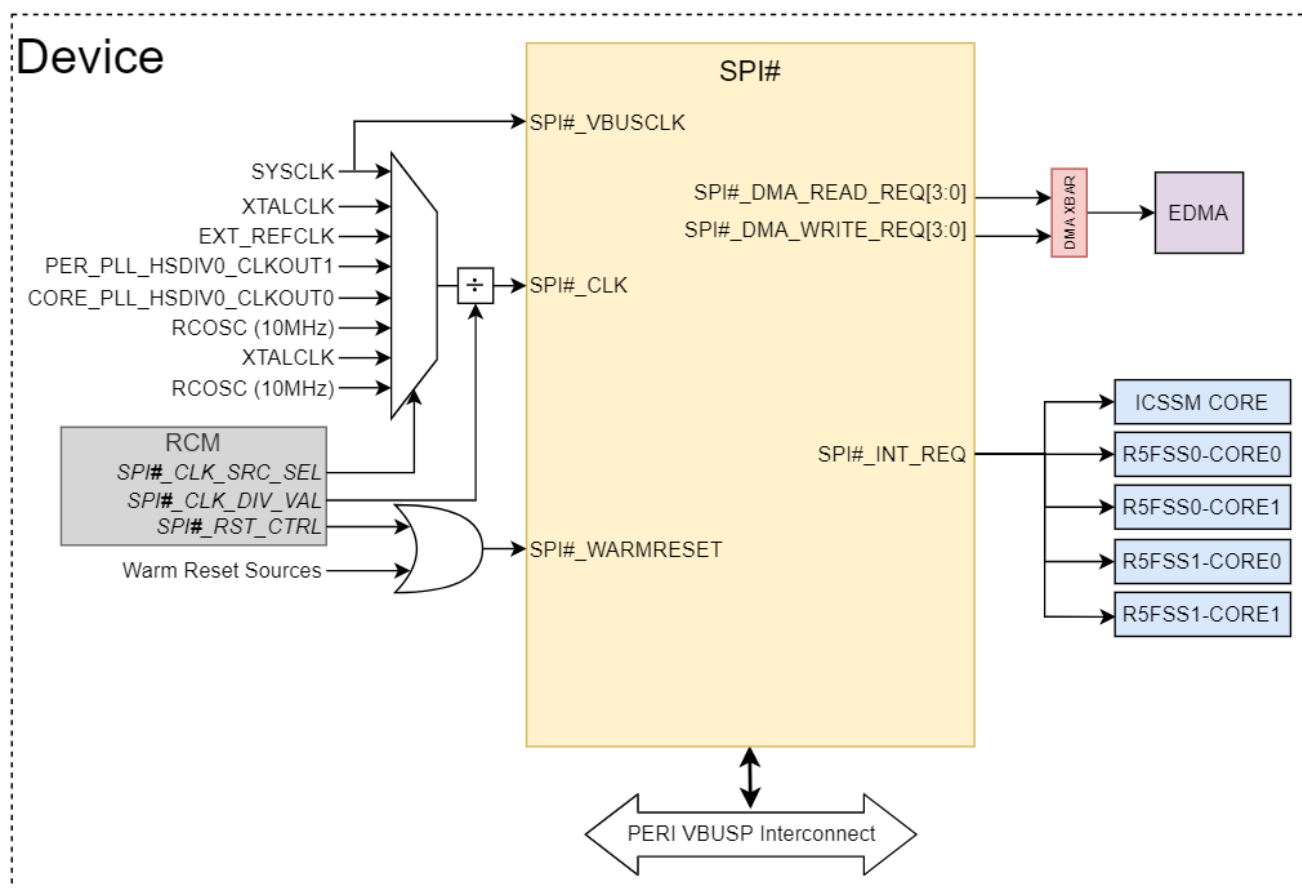

Figure 4-14. SPI Integration

The tables below summarize the device integration details of SPI# (where # = 0, 1, 2, 3, 4).

Table 4-20. SPI/Device Integration

This table describes the module device integration details.

Module Instance	Device Allocation	SoC Interconnect
SPI0	✓	PERI VBUSP Interconnect
SPI1	✓	PERI VBUSP Interconnect
SPI2	✓	PERI VBUSP Interconnect
SPI3	✓	PERI VBUSP Interconnect
SPI4	✓	PERI VBUSP Interconnect

Table 4-21. SPIClocks

This table describes the module clocking signals.

Module Instance	Module Clock Input	Source Clock Signal	Source	Default Freq	Description
SPI0	SPI0_ICLK (VBUSP_CLK)	SYS_CLK	PLL_CORE_CLK: HSDIV0_CLKOUT0	200 MHz	SPI0 VBUS Clock
	SPI0_FCLK (SPI_CLK)	XTALCLK	External XTAL	25 MHz	SPI0 Interface Clock
		EXT_REFCLK	External Reference Clock (EXT_REFCLK)	100 MHz	
		SYS_CLK	PLL_CORE_CLK: HSDIV0_CLKOUT0	200 MHz	
		DPLL_PER_HSDIV0_CLK OUT1	PLL_PER_CLK: HSDIV0_CLKOUT1	192 MHz	
		DPLL_CORE_HSDIV0_CL KOUT0	PLL_CORE_CLK: HSDIV0_CLKOUT1	400 MHz	
		RCCLK10M	Internal 10 MHz RC Oscillator (RCCLK10M)	10 MHz	
		XTALCLK	External XTAL	25 MHz	
		RCCLK10M	Internal 10 MHz RC Oscillator (RCCLK10M)	10 MHz	
SPI1	SPI1_ICLK (VBUSP_CLK)	SYS_CLK	PLL_CORE_CLK: HSDIV0_CLKOUT0	200 MHz	SPI1 VBUS Clock
	SPI1_FCLK (SPI_CLK)	XTALCLK	External XTAL	25 MHz	SPI1 Interface Clock
		EXT_REFCLK	External Reference Clock (EXT_REFCLK)	100 MHz	
		SYS_CLK	PLL_CORE_CLK: HSDIV0_CLKOUT0	200 MHz	
		DPLL_PER_HSDIV0_CLK OUT1	PLL_PER_CLK: HSDIV0_CLKOUT1	192 MHz	
		DPLL_CORE_HSDIV0_CL KOUT0	PLL_CORE_CLK: HSDIV0_CLKOUT1	400 MHz	
		RCCLK10M	Internal 10 MHz RC Oscillator (RCCLK10M)	10 MHz	
		XTALCLK	External XTAL	25 MHz	
		RCCLK10M	Internal 10 MHz RC Oscillator (RCCLK10M)	10 MHz	

Table 4-21. SPI/Clocks (continued)

This table describes the module clocking signals.

Module Instance	Module Clock Input	Source Clock Signal	Source	Default Freq	Description
SPI2	SPI2_ICLK (VBUSP_CLK)	SYS_CLK	PLL_CORE_CLK: HSDIV0_CLKOUT0	200 MHz	SPI2 VBUS Clock
	SPI2_FCLK (SPI_CLK)	XTALCLK	External XTAL	25 MHz	SPI2 Interface Clock
		EXT_REFCLK	External Reference Clock (EXT_REFCLK)	100 MHz	
		SYS_CLK	PLL_CORE_CLK: HSDIV0_CLKOUT0	200 MHz	
		DPLL_PER_HSDIV0_CLK OUT1	PLL_PER_CLK: HSDIV0_CLKOUT1	192 MHz	
		DPLL_CORE_HSDIV0_CLK OUT0	PLL_CORE_CLK: HSDIV0_CLKOUT1	400 MHz	
		RCCLK10M	Internal 10 MHz RC Oscillator (RCCLK10M)	10 MHz	
		XTALCLK	External XTAL	25 MHz	
		RCCLK10M	Internal 10 MHz RC Oscillator (RCCLK10M)	10 MHz	
SPI3	SPI3_ICLK (VBUSP_CLK)	SYS_CLK	PLL_CORE_CLK: HSDIV0_CLKOUT0	200 MHz	SPI3 VBUS Clock
	SPI3_FCLK (SPI_CLK)	XTALCLK	External XTAL	25 MHz	SPI3 Interface Clock
		EXT_REFCLK	External Reference Clock (EXT_REFCLK)	100 MHz	
		SYS_CLK	PLL_CORE_CLK: HSDIV0_CLKOUT0	200 MHz	
		DPLL_PER_HSDIV0_CLK OUT1	PLL_PER_CLK: HSDIV0_CLKOUT1	192 MHz	
		DPLL_CORE_HSDIV0_CLK OUT0	PLL_CORE_CLK: HSDIV0_CLKOUT1	400 MHz	
		RCCLK10M	Internal 10 MHz RC Oscillator (RCCLK10M)	10 MHz	
		XTALCLK	External XTAL	25 MHz	
		RCCLK10M	Internal 10 MHz RC Oscillator (RCCLK10M)	10 MHz	

Table 4-21. SPIClocks (continued)

This table describes the module clocking signals.

Module Instance	Module Clock Input	Source Clock Signal	Source	Default Freq	Description
SPI4	SPI4_ICLK (VBUSP_CLK)	SYS_CLK	PLL_CORE_CLK: HSDIV0_CLKOUT0	200 MHz	SPI4 VBUS Clock
	SPI4_FCLK (SPI_CLK)	XTALCLK	External XTAL	25 MHz	SPI4 Interface Clock
		EXT_REFCLK	External Reference Clock (EXT_REFCLK)	100 MHz	
		SYS_CLK	PLL_CORE_CLK: HSDIV0_CLKOUT0	200 MHz	
		DPLL_PER_HSDIV0_CLK OUT1	PLL_PER_CLK: HSDIV0_CLKOUT1	192 MHz	
		DPLL_CORE_HSDIV0_CL KOUT0	PLL_CORE_CLK: HSDIV0_CLKOUT1	400 MHz	
		RCCLK10M	Internal 10 MHz RC Oscillator (RCCLK10M)	10 MHz	
		XTALCLK	External XTAL	25 MHz	
RCCLK10M	Internal 10 MHz RC Oscillator (RCCLK10M)	10 MHz			

Table 4-22. SPI Resets

This table describes the module reset signals.

Module Instance	Module Reset Input	Source Reset Signal	Source	Description
SPI0	SPI0_RST	Warm Reset (MOD_G_RST)	RCM + Warm Reset Sources	SPI0 Asynchronous Reset
SPI1	SPI1_RST	Warm Reset (MOD_G_RST)	RCM + Warm Reset Sources	SPI1 Asynchronous Reset
SPI2	SPI2_RST	Warm Reset (MOD_G_RST)	RCM + Warm Reset Sources	SPI2 Asynchronous Reset
SPI3	SPI3_RST	Warm Reset (MOD_G_RST)	RCM + Warm Reset Sources	SPI3 Asynchronous Reset
SPI4	SPI4_RST	Warm Reset (MOD_G_RST)	RCM + Warm Reset Sources	SPI4 Asynchronous Reset

Table 4-23. SPI Interrupt Requests

This table describes the module interrupt requests.

Module Instance	Module Interrupt Signal	Destination Interrupt Input	Destination	Type	Description
SPI0	spi0_int_req	spi0_int_req	ALL R5FSS Cores ICSSM Core	Level	SPI0 IP Status Information
SPI1	spi1_int_req	spi1_int_req	ALL R5FSS Cores ICSSM Core	Level	SPI1 IP Status Information
SPI2	spi2_int_req	spi2_int_req	ALL R5FSS Cores ICSSM Core	Level	SPI2 IP Status Information
SPI3	spi3_int_req	spi3_int_req	ALL R5FSS Cores ICSSM Core	Level	SPI3 IP Status Information

Table 4-23. SPI Interrupt Requests (continued)

This table describes the module interrupt requests.

Module Instance	Module Interrupt Signal	Destination Interrupt Input	Destination	Type	Description
SPI4	spi4_int_req	spi4_int_req	ALL R5FSS Cores ICSSM Core	Level	SPI4 IP Status Information

Table 4-24. SPI DMA Requests

This table describes the module DMA requests.

Module Instance	Module DMA Event	Destination DMA Event Input	Destination	Type	Description
SPI0	SPI0_DMA_READ_0	spi0_dma_read_req[0]	EDMA Crossbar (EDMA_XBAR)	Level	SPI0 DMA Read Request
	SPI0_DMA_READ_1	spi0_dma_read_req[1]			
	SPI0_DMA_READ_2	spi0_dma_read_req[2]			
	SPI0_DMA_READ_3	spi0_dma_read_req[3]			
	SPI0_DMA_WRITE_0	spi0_dma_write_req[0]			SPI0 DMA Write Request
	SPI0_DMA_WRITE_1	spi0_dma_write_req[1]			
	SPI0_DMA_WRITE_2	spi0_dma_write_req[2]			
	SPI0_DMA_WRITE_3	spi0_dma_write_req[3]			
SPI1	SPI1_DMA_READ_0	spi1_dma_read_req[0]	EDMA Crossbar (EDMA_XBAR)	Level	SPI1 DMA Read Request
	SPI1_DMA_READ_1	spi1_dma_read_req[1]			
	SPI1_DMA_READ_2	spi1_dma_read_req[2]			
	SPI1_DMA_READ_3	spi1_dma_read_req[3]			
	SPI1_DMA_WRITE_0	spi1_dma_write_req[0]			SPI1 DMA Write Request
	SPI1_DMA_WRITE_1	spi1_dma_write_req[1]			
	SPI1_DMA_WRITE_2	spi1_dma_write_req[2]			
	SPI1_DMA_WRITE_3	spi1_dma_write_req[3]			
SPI2	SPI2_DMA_READ_0	spi2_dma_read_req[0]	EDMA Crossbar (EDMA_XBAR)	Level	SPI2 DMA Read Request
	SPI2_DMA_READ_1	spi2_dma_read_req[1]			
	SPI2_DMA_READ_2	spi2_dma_read_req[2]			
	SPI2_DMA_READ_3	spi2_dma_read_req[3]			
	SPI2_DMA_WRITE_0	spi2_dma_write_req[0]			SPI2 DMA Write Request
	SPI2_DMA_WRITE_1	spi2_dma_write_req[1]			
	SPI2_DMA_WRITE_2	spi2_dma_write_req[2]			
	SPI2_DMA_WRITE_3	spi2_dma_write_req[3]			
SPI3	SPI3_DMA_READ_0	spi3_dma_read_req[0]	EDMA Crossbar (EDMA_XBAR)	Level	SPI3 DMA Read Request
	SPI3_DMA_READ_1	spi3_dma_read_req[1]			
	SPI3_DMA_READ_2	spi3_dma_read_req[2]			
	SPI3_DMA_READ_3	spi3_dma_read_req[3]			
	SPI3_DMA_WRITE_0	spi3_dma_write_req[0]			SPI3 DMA Write Request
	SPI3_DMA_WRITE_1	spi3_dma_write_req[1]			
	SPI3_DMA_WRITE_2	spi3_dma_write_req[2]			
	SPI3_DMA_WRITE_3	spi3_dma_write_req[3]			

Table 4-24. SPI DMA Requests (continued)

This table describes the module DMA requests.

Module Instance	Module DMA Event	Destination DMA Event Input	Destination	Type	Description
SPI4	SPI4_DMA_READ_0	spi4_dma_read_req[0]	EDMA Crossbar (EDMA_XBAR)	Level	SPI4 DMA Read Request
	SPI4_DMA_READ_1	spi2_dma_read_req[1]			
	SPI4_DMA_READ_2	spi4_dma_read_req[2]			
	SPI4_DMA_READ_3	spi4_dma_read_req[3]			
	SPI4_DMA_WRITE_0	spi4_dma_write_req[0]			SPI4 DMA Write Request
	SPI4_DMA_WRITE_1	spi4_dma_write_req[1]			
	SPI4_DMA_WRITE_2	spi4_dma_write_req[2]			
	SPI4_DMA_WRITE_3	spi4_dma_write_req[3]			

Note

For more information on the interconnects, see the *System Interconnect* chapter.

For more information on power, reset, and clock management, see the corresponding sections within the *Device Configuration* chapter.

For more information on the device interrupt controllers, see the *Interrupt Controllers* chapter.

4.12 UART Integration

There are 6x UART modules integrated in the device. The diagram below provides a visual representation of the device integration details.

ADVANCE INFORMATION

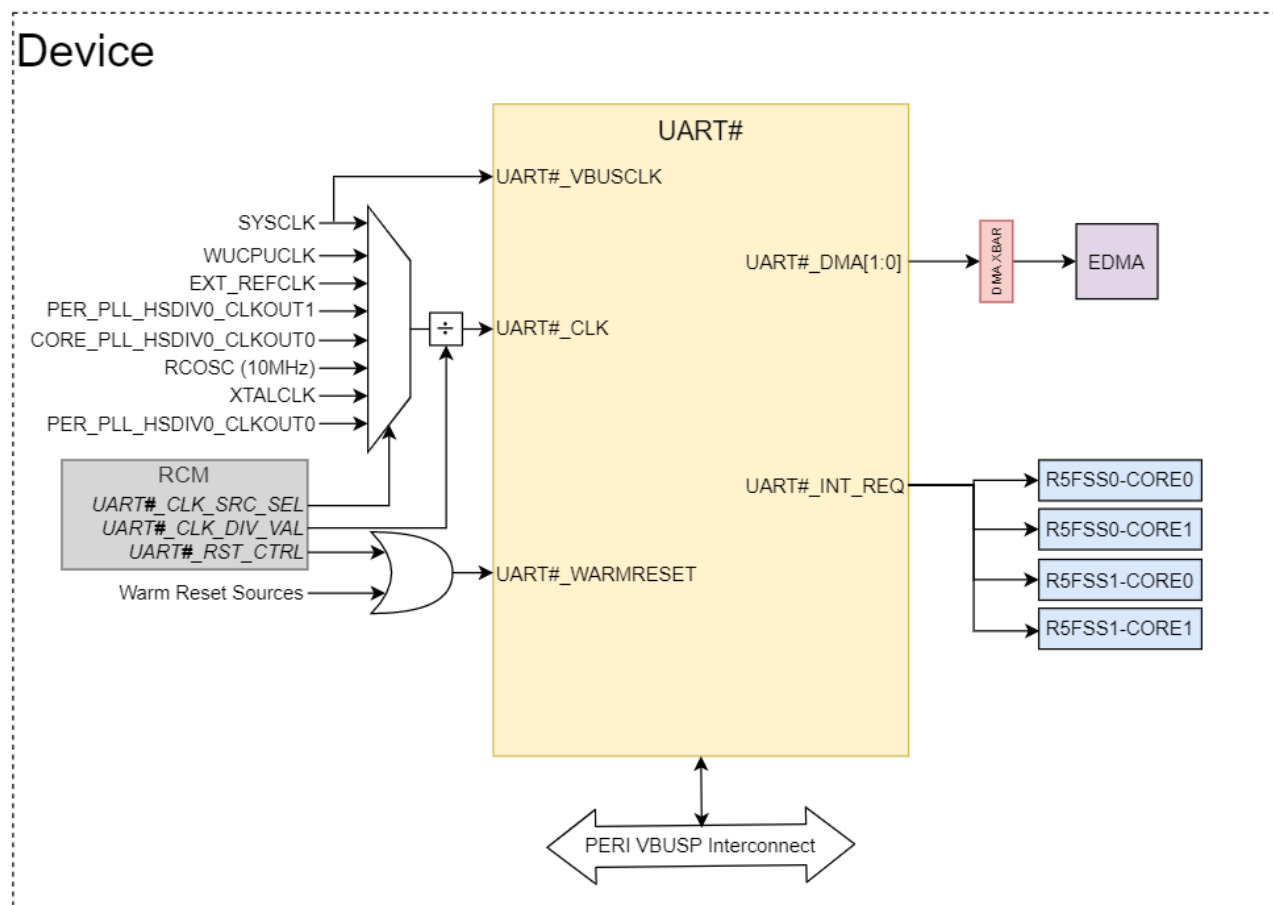

= 0, 1, 2, 3, 4, 5

Figure 4-15. UART Integration

The tables below summarize the device integration details of UART# (where # = 0, 1, 2, 3, 4, 5) in the device.

Table 4-25. UART Device Integration

This table describes the module device integration details.

Module Instance	Device Allocation	SoC Interconnect
UART0	✓	PERI VBUSP Interconnect
UART1	✓	PERI VBUSP Interconnect
UART2	✓	PERI VBUSP Interconnect
UART3	✓	PERI VBUSP Interconnect
UART4	✓	PERI VBUSP Interconnect
UART5	✓	PERI VBUSP Interconnect

Table 4-26. UART Clocks

This table describes the module clocking signals.

Module Instance	Module Clock Input	Source Clock Signal	Source	Default Freq	Description
UART0	UART0_ICLK (VBUSP_CLK)	SYS_CLK	PLL_CORE_CLK: HSDIV0_CLKOUT0	200 MHz	UART0 VBUS Clock
	UART0_FCLK (UART_CLK)	XTALCLK	External XTAL	25 MHz	UART0 Interface Clock
		EXT_REFCLK	External Reference Clock (EXT_REFCLK)	100 MHz	
		SYS_CLK	PLL_CORE_CLK: HSDIV0_CLKOUT0	200 MHz	
		DPLL_PER_HSDIV0_CLK OUT1	PLL_PER_CLK: HSDIV0_CLKOUT1	192 MHz	
		DPLL_CORE_HSDIV0_CL KOUT0	PLL_CORE_CLK: HSDIV0_CLKOUT0	400 MHz	
		RCCLK10M	Internal 10 MHz RC Oscillator (RCCLK10M)	10 MHz	
		XTALCLK	External XTAL	25 MHz	
		DPLL_PER_HSDIV0_CLK OUT0	PLL_PER_CLK:HSDIV0_C LKOUT0	160 MHz	
UART1	UART1_ICLK (VBUSP_CLK)	SYS_CLK	PLL_CORE_CLK: HSDIV0_CLKOUT0	200 MHz	UART1 VBUS Clock
	UART1_FCLK (UART_CLK)	XTALCLK	External XTAL	25 MHz	UART1 Interface Clock
		EXT_REFCLK	External Reference Clock (EXT_REFCLK)	100 MHz	
		SYS_CLK	PLL_CORE_CLK: HSDIV0_CLKOUT0	200 MHz	
		DPLL_PER_HSDIV0_CLK OUT1	PLL_PER_CLK: HSDIV0_CLKOUT1	192 MHz	
		DPLL_CORE_HSDIV0_CL KOUT0	PLL_CORE_CLK: HSDIV0_CLKOUT0	400 MHz	
		RCCLK10M	Internal 10 MHz RC Oscillator (RCCLK10M)	10 MHz	
		XTALCLK	External XTAL	25 MHz	
		DPLL_PER_HSDIV0_CLK OUT0	PLL_PER_CLK:HSDIV0_C LKOUT0	160 MHz	

Table 4-26. UART Clocks (continued)

This table describes the module clocking signals.

Module Instance	Module Clock Input	Source Clock Signal	Source	Default Freq	Description
UART2	UART2_ICLK (VBUSP_CLK)	SYS_CLK	PLL_CORE_CLK: HSDIV0_CLKOUT0	200 MHz	UART2 VBUS Clock
	UART2_FCLK (UART_CLK)	XTALCLK	External XTAL	25 MHz	UART2 Interface Clock
		EXT_REFCLK	External Reference Clock (EXT_REFCLK)	100 MHz	
		SYS_CLK	PLL_CORE_CLK: HSDIV0_CLKOUT0	200 MHz	
		DPLL_PER_HSDIV0_CLK OUT1	PLL_PER_CLK: HSDIV0_CLKOUT1	192 MHz	
		DPLL_CORE_HSDIV0_CL KOUT0	PLL_CORE_CLK: HSDIV0_CLKOUT0	400 MHz	
		RCCLK10M	Internal 10 MHz RC Oscillator (RCCLK10M)	10 MHz	
		XTALCLK	External XTAL	25 MHz	
DPLL_PER_HSDIV0_CLK OUT0	PLL_PER_CLK:HSDIV0_C LKOUT0	160 MHz			
UART3	UART3_ICLK (VBUSP_CLK)	SYS_CLK	PLL_CORE_CLK: HSDIV0_CLKOUT0	200 MHz	UART3 VBUS Clock
	UART3_FCLK (UART_CLK)	XTALCLK	External XTAL	25 MHz	UART3 Interface Clock
		EXT_REFCLK	External Reference Clock (EXT_REFCLK)	100 MHz	
		SYS_CLK	PLL_CORE_CLK: HSDIV0_CLKOUT0	200 MHz	
		DPLL_PER_HSDIV0_CLK OUT1	PLL_PER_CLK: HSDIV0_CLKOUT1	192 MHz	
		DPLL_CORE_HSDIV0_CL KOUT0	PLL_CORE_CLK: HSDIV0_CLKOUT0	400 MHz	
		RCCLK10M	Internal 10 MHz RC Oscillator (RCCLK10M)	10 MHz	
		XTALCLK	External XTAL	25 MHz	
DPLL_PER_HSDIV0_CLK OUT0	PLL_PER_CLK:HSDIV0_C LKOUT0	160 MHz			

Table 4-26. UART Clocks (continued)

This table describes the module clocking signals.

Module Instance	Module Clock Input	Source Clock Signal	Source	Default Freq	Description
UART4	UART4_ICLK (VBUSP_CLK)	SYS_CLK	PLL_CORE_CLK: HSDIV0_CLKOUT0	200 MHz	UART4 VBUS Clock
	UART4_FCLK (UART_CLK)	XTALCLK	External XTAL	25 MHz	UART4 Interface Clock
		EXT_REFCLK	External Reference Clock (EXT_REFCLK)	100 MHz	
		SYS_CLK	PLL_CORE_CLK: HSDIV0_CLKOUT0	200 MHz	
		DPLL_PER_HSDIV0_CLK OUT1	PLL_PER_CLK: HSDIV0_CLKOUT1	192 MHz	
		DPLL_CORE_HSDIV0_CLK KOUT0	PLL_CORE_CLK: HSDIV0_CLKOUT0	400 MHz	
		RCCLK10M	Internal 10 MHz RC Oscillator (RCCLK10M)	10 MHz	
		XTALCLK	External XTAL	25 MHz	
DPLL_PER_HSDIV0_CLK OUT0	PLL_PER_CLK:HSDIV0_C LKOUT0	160 MHz			
UART5	UART5_ICLK (VBUSP_CLK)	SYS_CLK	PLL_CORE_CLK: HSDIV0_CLKOUT0	200 MHz	UART5 VBUS Clock
	UART5_FCLK (UART_CLK)	XTALCLK	External XTAL	25 MHz	UART5 Interface Clock
		EXT_REFCLK	External Reference Clock (EXT_REFCLK)	100 MHz	
		SYS_CLK	PLL_CORE_CLK: HSDIV0_CLKOUT0	200 MHz	
		DPLL_PER_HSDIV0_CLK OUT1	PLL_PER_CLK: HSDIV0_CLKOUT1	192 MHz	
		DPLL_CORE_HSDIV0_CLK KOUT0	PLL_CORE_CLK: HSDIV0_CLKOUT0	400 MHz	
		RCCLK10M	Internal 10 MHz RC Oscillator (RCCLK10M)	10 MHz	
		XTALCLK	External XTAL	25 MHz	
DPLL_PER_HSDIV0_CLK OUT0	PLL_PER_CLK:HSDIV0_C LKOUT0	160 MHz			

Table 4-27. UART Resets

This table describes the module reset signals.

Module Instance	Module Reset Input	Source Reset Signal	Source	Description
UART0	UART0_RST(VBUSP_RSTn)	Warm Reset (MOD_G_RST)	RCM + Warm Reset Sources	UART0 Asynchronous Reset
UART1	UART1_RST(VBUSP_RSTn)	Warm Reset (MOD_G_RST)	RCM + Warm Reset Sources	UART1 Asynchronous Reset

Table 4-27. UART Resets (continued)

This table describes the module reset signals.

Module Instance	Module Reset Input	Source Reset Signal	Source	Description
UART2	UART2_RST	Warm Reset (MOD_G_RST)	RCM + Warm Reset Sources	UART2 Asynchronous Reset
UART3	UART3_RST	Warm Reset (MOD_G_RST)	RCM + Warm Reset Sources	UART3 Asynchronous Reset
UART4	UART4_RST	Warm Reset (MOD_G_RST)	RCM + Warm Reset Sources	UART4 Asynchronous Reset
UART5	UART5_RST	Warm Reset (MOD_G_RST)	RCM + Warm Reset Sources	UART5 Asynchronous Reset

Table 4-28. UART Interrupt Requests

This table describes the module interrupt requests.

Module Instance	Module Interrupt Signal	Destination Interrupt Input	Destination	Type	Description
UART0	uart0_int_req	uart0_int_req	ALL R5FSS Cores ICSSM Core	Level	UART0 IP Status Information
UART1	uart1_int_req	uart1_int_req	ALL R5FSS Cores ICSSM Core		UART1 IP Status Information
UART2	uart2_int_req	uart2_int_req	ALL R5FSS Cores ICSSM Core		UART2 IP Status Information
UART3	uart3_int_req	uart4_int_req	ALL R5FSS Cores ICSSM Core		UART3 IP Status Information
UART4	uart4_int_req	uart4_int_req	ALL R5FSS Cores ICSSM Core		UART4 IP Status Information
UART5	uart5_int_req	uart5_int_req	ALL R5FSS Cores ICSSM Core		UART5 IP Status Information

Table 4-29. UART DMA Requests

This table describes the module DMA requests.

Module Instance	Module DMA Event	Destination DMA Event Input	Destination	Type	Description
UART0	UART0_DMA_0	UART0_dma_req[0]	EDMA Crossbar (DMA_XBAR)	Level	UART0 DMA Request
	UART0_DMA_1	UART0_dma_req[1]			
UART1	UART1_DMA_0	UART1_dma_req[0]	EDMA Crossbar (DMA_XBAR)	Level	UART1 DMA Request
	UART1_DMA_1	UART1_dma_req[1]			
UART2	UART2_DMA_0	UART2_dma_req[0]	EDMA Crossbar (DMA_XBAR)	Level	UART2 DMA Request
	UART2_DMA_1	UART2_dma_req[1]			
UART3	UART3_DMA_0	UART3_dma_req[0]	EDMA Crossbar (DMA_XBAR)	Level	UART3 DMA Request
	UART3_DMA_1	UART3_dma_req[1]			
UART4	UART4_DMA_0	UART4_dma_req[0]	EDMA Crossbar (DMA_XBAR)	Level	UART4 DMA Request
	UART4_DMA_1	UART4_dma_req[1]			
UART5	UART5_DMA_0	UART5_dma_req[0]	EDMA Crossbar (DMA_XBAR)	Level	UART5 DMA Request
	UART5_DMA_1	UART5_dma_req[1]			

Note

For more information on the interconnects, see the *System Interconnect* chapter.

For more information on power, reset, and clock management, see the corresponding sections within the *Device Configuration* chapter.

For more information on the device interrupt controllers, see the *Interrupt Controllers* chapter.

4.13 CPSW3G Integration

There is 1x CPSW3G module integrated in the device. The diagram below provides a visual representation of the device integration details.

ADVANCE INFORMATION

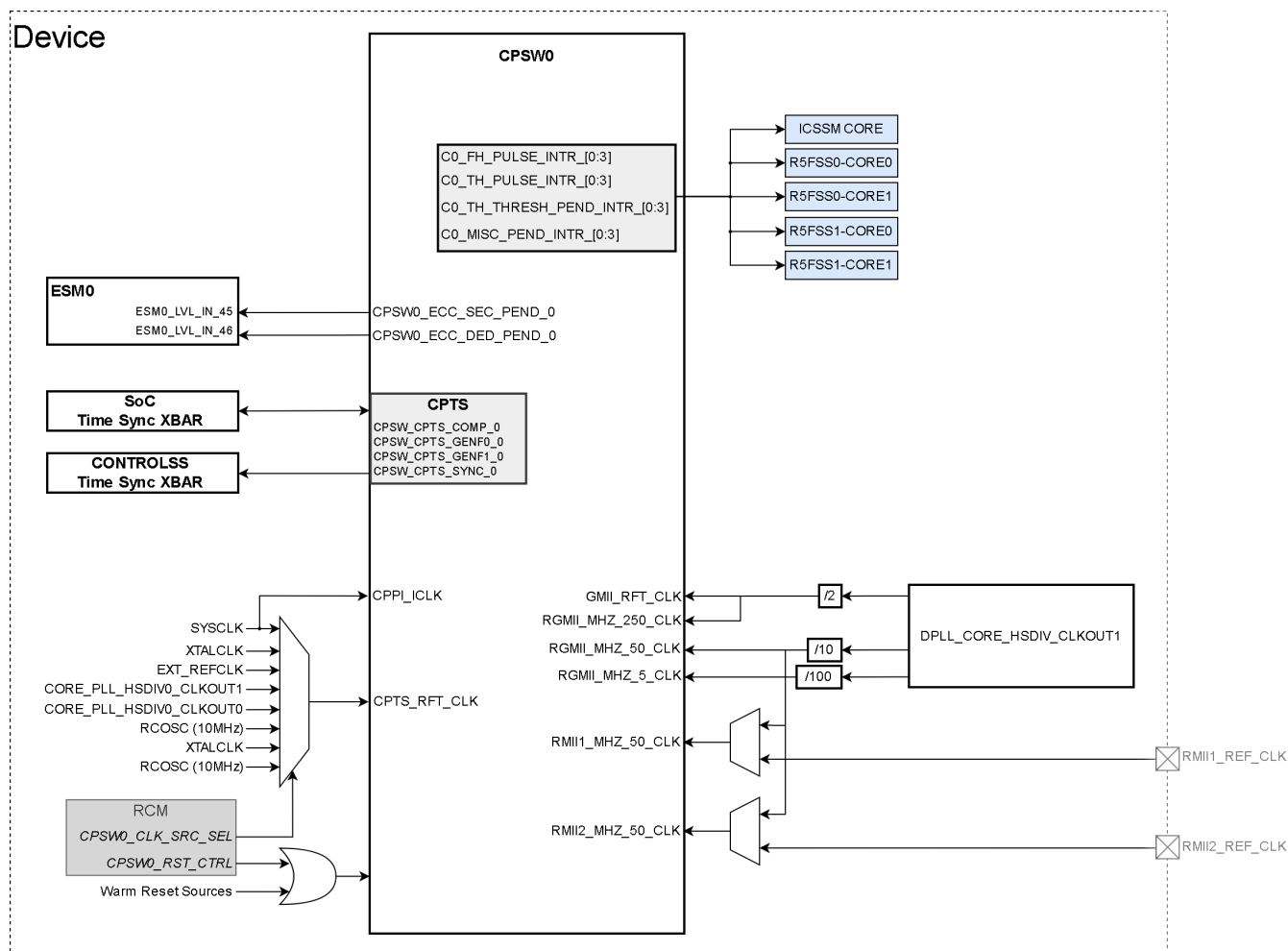

Figure 4-16. CPSW3G Integration Diagram

The tables below summarize the device integration details of CPSW0.

Table 4-30. CPSW0 Device Integration

This table describes the module device integration details.

Module Instance	Device Allocation	SoC Interconnect
CPSW0	✓	INFRA0 VBUSP Interconnect

Table 4-31. CPSW0 Clocks

This table describes the module clocking signals.

Module Instance	Module Clock Input	Source Clock Signal	Source	Default Freq	Description	
CPSW0	CPPI_ICLK	SYS_CLK	PLL_CORE_CLK: HSDIV0_CLKOUT0	200 MHz	CPSW0 Interface Clock	
	CPTS_RFT_CLK	XTACLK	XTACLK	External XTAL	25 MHz	CPSW0 Interface Clock
		EXT_REFCLK	EXT_REFCLK	External Reference Clock (EXT_REFCLK)	100 MHz	CPSW0 Interface Clock
		SYS_CLK	SYS_CLK	PLL_CORE_CLK: HSDIV0_CLKOUT0	200 MHz	CPSW0 Interface Clock
		DPLL_CORE_HSDIV0_CLKOUT1	DPLL_CORE_HSDIV0_CLKOUT1	PLL_CORE_CLK: HSDIV0_CLKOUT1	500 MHz	CPSW0 Interface Clock
		DPLL_CORE_HSDIV0_CLKOUT0	DPLL_CORE_HSDIV0_CLKOUT0	PLL_CORE_CLK: HSDIV0_CLKOUT0	400 MHz	CPSW0 Interface Clock
		RCCLK10M	RCCLK10M	Internal 10 MHz RC Oscillator (RCCLK10M)	10 MHz	CPSW0 Interface Clock
		XTALCLK	XTALCLK	External XTAL	25 MHz	CPSW0 Interface Clock
		RCCLK10M	RCCLK10M	Internal 10 MHz RC Oscillator (RCCLK10M)	10 MHz	CPSW0 Interface Clock
	GMII_RFT_CLK	RGMII_250_CLK	RGMII 250 MHz Clock	250 MHz	CPSW0 Interface Clock	
	RMII1_MHZ_50_CLK	RGMII_50_CLK	RGMII 50 MHz Clock	50 MHz	CPSW0 Interface Clock	
		RMII1_REF_CLK	RMII1 Reference Clock	50 MHz ¹	CPSW0 Interface Clock	
	RMII2_MHZ_50_CLK	RGMII_50_CLK	RGMII 50 MHz Clock	50 MHz	CPSW0 Interface Clock	
		RMII2_REF_CLK	RMII2 Reference Clock	50 MHz ¹	CPSW0 Interface Clock	
	RGMII_MHZ_50_CLK	RGMII_50_CLK	RGMII 50 MHz Clock	50 MHz	CPSW0 Interface Clock	
	RGMII_MHZ_5_CLK	RGMII_5_CLK	RGMII 5 MHz Clock	5 MHz	CPSW0 Interface Clock	
RGMII_MHZ_250_CLK	RGMII_250_CLK	RGMII 250 MHz Clock	250 MHz	CPSW0 Interface Clock		

Note

¹The RMIIx_REF_CLK input pin can be drive by an external clock reference source. 50 MHz is required for proper operation.

Table 4-32. CPSW0 Resets

This table describes the module reset signals.

Module Instance	Module Reset Input	Source Reset Signal	Source	Description
CPSW0	CPSW_RST	Warm Reset (MOD_G_RST)	RCM + Warm Reset Sources	CPSW0 Asynchronous Reset

Table 4-33. CPSW0 Interrupt Requests

This table describes the module interrupt requests.

Module Instance	Module Interrupt Signal	Destination Interrupt Input	Destination	Type	Description
CPSW0	C0_FH_PULSE_INTR[0:3]	C0_FH_PULSE_INTR	All R5FSS Cores ICSSM Core	Level	FHost (from host to Ethernet) paced pulse interrupt
	C0_TH_PULSE_INTR[0:3]	C0_TH_PULSE_INTR	All R5FSS Cores ICSSM Core	Level	THost (from Ethernet to host) paced pulse interrupt
	C0_TH_THRESH_PEND_INTR[0:3]	C0_TH_THRESH_PEND_INTR	All R5FSS Cores ICSSM Core	Level	THost (from Ethernet to host) non-paced pulse interrupt
	C0_MISC_PEND_INTR[0:3]	C0_MISC_PEND_INTR	All R5FSS Cores ICSSM Core	Level	Miscellaneous non-paced pulse interrupt
	CPSW_ECC_SEC_PEND_INTR	ECC_SEC_PEND_INTR	ESM	Level	ECC SEC pulse interrupt – output from CPSW ECC module.
	CPSW_ECC_DED_PEND_INTR	ECC_DED_PEND_INTR	ESM	Level	ECC DED pulse interrupt – output from CPSW ECC module.

Table 4-34. CPSW0 Time Sync and Compare Event

This table describes the module capture event inputs.

Module Instance	Module Event	Destination Event Input	Destination	Type	Description
CPSW0	CPSW0_CPTS_COMP	SoC_TimeSyncXBAR[0:3]	CPSW0_CPTS_COMP_INTR	Level	CPSW0 Compare Event Interrupt
		C2K_TimeSyncXBAR[0:3]			
	CPSW0_CPTS_GENF0	SoC_TimeSyncXBAR[0:3]	CPSW0_CPTS_GENF0_INTR	Level	CPSW0 CPTS generator function event interrupt 0
		C2K_TimeSyncXBAR[0:3]			
	CPSW0_CPTS_GENF1	SoC_TimeSyncXBAR[0:3]	CPSW0_CPTS_GENF1_INTR	Level	CPSW0 CPTS generator function event interrupt 1
		C2K_TimeSyncXBAR[0:3]			
	CPSW0_CPTS_SYNC	SoC_TimeSyncXBAR[0:3]	CPSW0_CPTS_SYNC_INTR	Level	CPSW0 CPTS Sync Event Interrupt
		C2K_TimeSyncXBAR[0:3]			

Note

For more information on the interconnects, see the *System Interconnect* chapter.

For more information on power, reset, and clock management, see the corresponding sections within the *Device Configuration* chapter.

For more information on the device interrupt controllers, see the *Interrupt Controllers* chapter.

For pin information on RGMII_ID_MODE and RGMII_REFCLK_SEL, see Register information and the corresponding section within the *Device Configuration* chapter

4.14 MMCSD Integration

There is 1x MMCSD integrated in the device. The diagram below provides a visual representation of the device integration details.

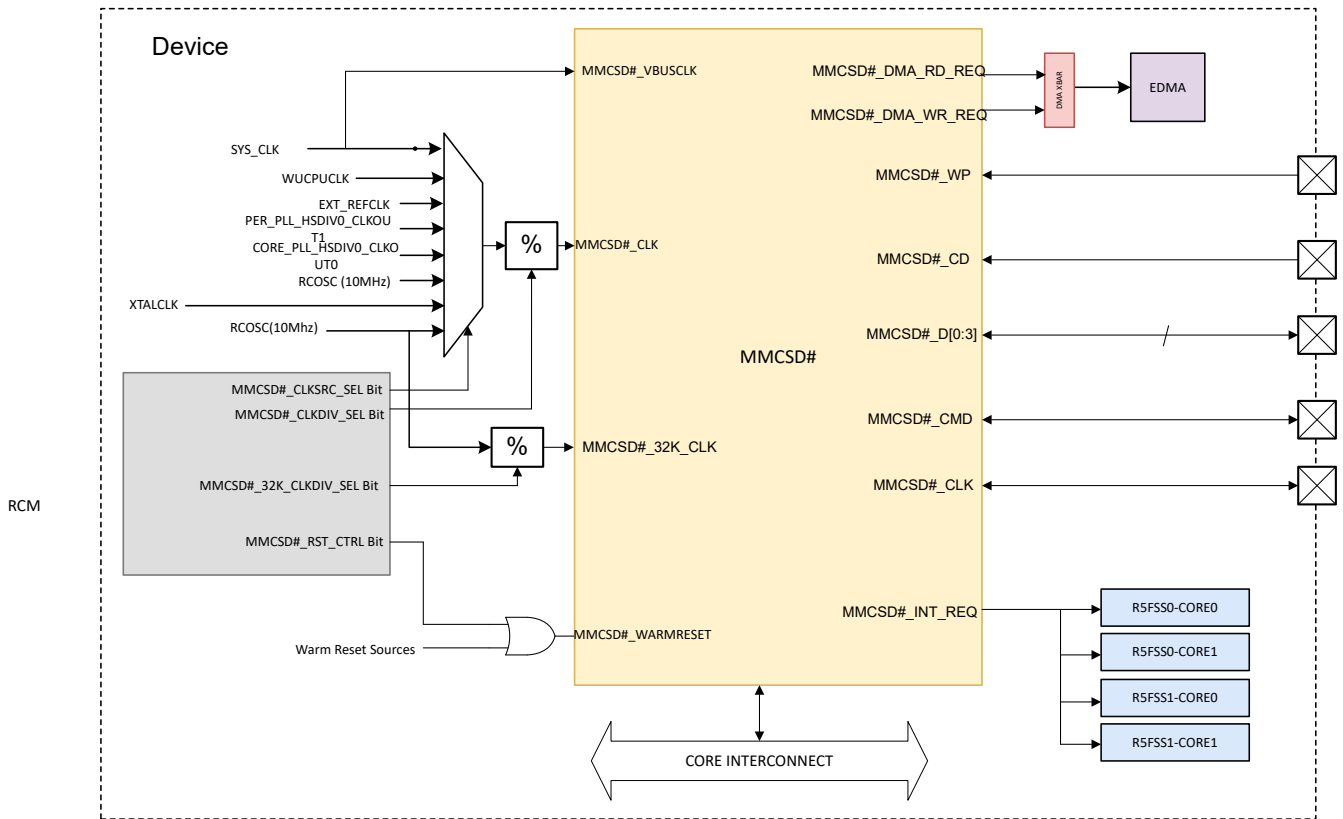

Figure 4-17. MMCSD Integration

The tables below summarize the device integration details of MMCSD.

Table 4-35. MMCSD Device Integration

This table describes the module integration details.

MMCSD Instance	Device Allocation	SoC Interconnect
MMCSD0	✓	CORE VBUSM Interconnect

ADVANCE INFORMATION

Table 4-36. MMCSD Clocks

This table describes the module clocking signals.

MMCSD Instance	MMCSD Clock Input	Source Clock Signal	Source	Default Freq	Description	
MMCSD0	MMCSD0_ICLK (VBUSP_CLK)	SYS_CLK	PLL_CORE_CLK: HSDIV0_CLKOUT0	200 MHz	MMCSD0 Interface Clock	
	MMCSD0_32K_CLK	MMCSD0_32K_CLK	XTALCLK	32 KHz	MMCSD0 Debounce Clock	
	MMCSD0_FCLK (MMCSD_CLK)	XTALCLK	XTALCLK	External XTAL	25 MHz	MMCSD0 Interface Clock
			EXT_REFCLK	External Reference Clock (EXT_REFCLK)	100 MHz	
		SYS_CLK	PLL_CORE_CLK: HSDIV0_CLKOUT0	200 MHz		
		DPLL_PER_HSDIV0_CLK OUT1	PLL_PER_CLK: HSDIV0_CLKOUT1	192 MHz		
		DPLL_CORE_HSDIV0_CLK KOUT0	PLL_CORE_CLK: HSDIV0_CLKOUT0	400 MHz		
		RCCLK10M	Internal 10 MHz RC Oscillator (RCCLK10M)	10 MHz		
		XTALCLK	External XTAL	25 MHz		
RCCLK10M	Internal 10 MHz RC Oscillator (RCCLK10M)	10 MHz				

Table 4-37. MMCSD Resets

This table describes the module reset signals.

MMCSD Instance	MMCSD Reset Input	Source Reset Signal	Source	Description
MMCSD0	MMCSD0_RST	Warm Reset (MOD_G_RST)	RCM + Warm Reset Sources	MMCSD0 Asynchronous Reset

Table 4-38. MMCSD Interrupt Requests

This table describes the module interrupt requests.

MMCSD Instance	MMCSD Interrupt Signal	Destination Interrupt Input	Destination	Type	Description
MMCSD0	MMCSD0_INT_req_0	MMCSD0_INT_req_0	ALL R5FSS Cores	Level	MMCSD0 Interrupt

Table 4-39. MMCSD DMA Requests

This table describes the module DMA requests.

MMCSD Instance	MMCSD DMA Event	Destination DMA Event Input	Destination	Type	Description
MMCSD0	MMCSD0_DMA_RD_REQ	MMCSD0_DMA_RD_REQ	EDMA Crossbar (DMA_XBAR)	Level	MMCSD0 DMA Read Request
	MMCSD0_DMA_WR_REQ	MMCSD0_DMA_WR_REQ			MMCSD0 DMA Write Request

Note

For more information on the interconnects, see the *System Interconnect* chapter.

For more information on power, reset, and clock management, see the corresponding sections within the *Device Configuration* chapter.

For more information on the device interrupt controllers, see the *Interrupt Controllers* chapter.

4.15 QSPI Integration (AM263x)

There is 1x QSPI module integrated in the device. The diagram below provides a visual representation of the device integration details.

ADVANCE INFORMATION

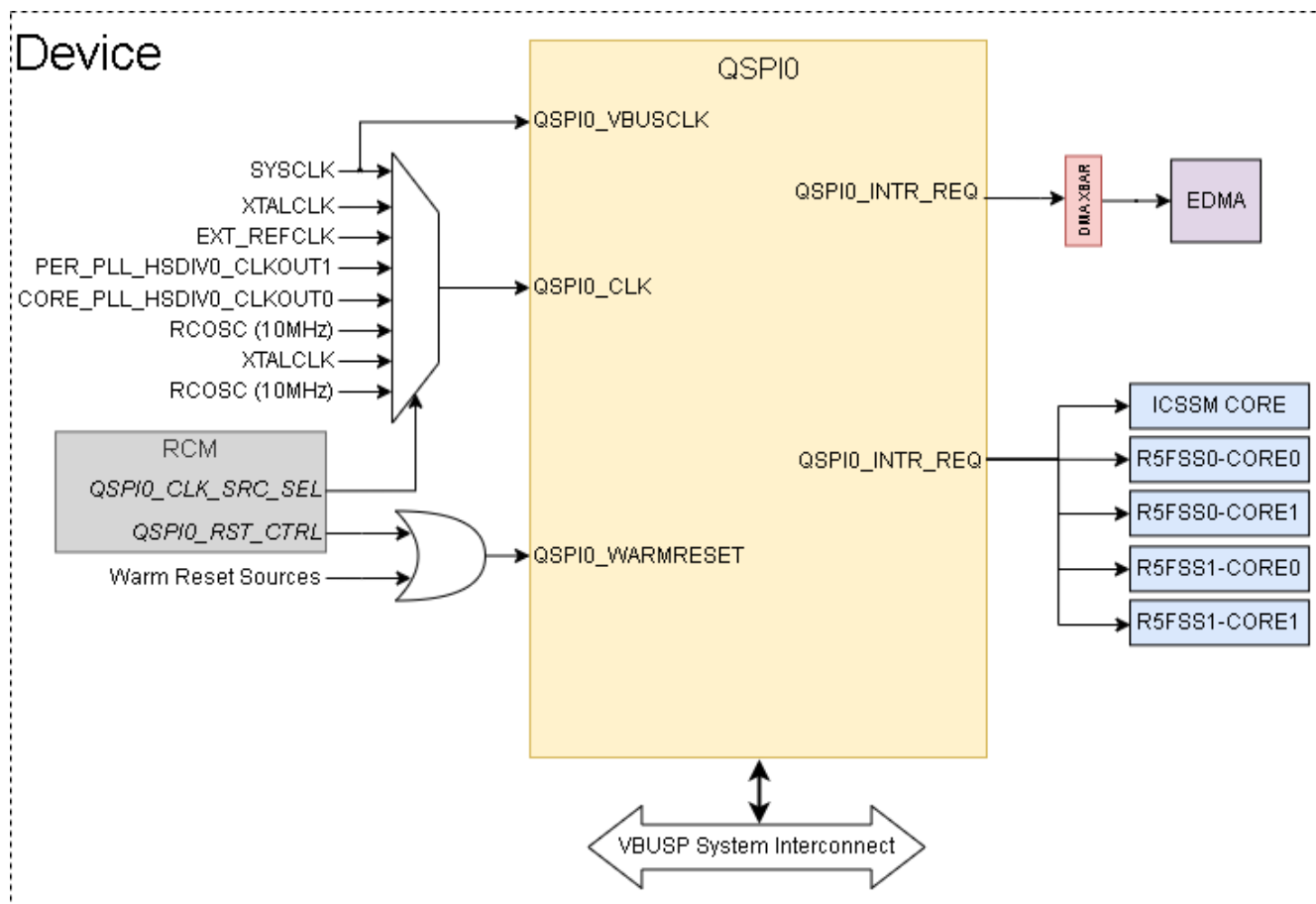

Figure 4-18. QSPI Integration Diagram

The tables below summarize the device integration details of QSPI.

Table 4-40. QSPI Device Integration

This table describes the module device integration details.

Module Instance	Device Allocation	SoC Interconnect
QSPI0	✓	VBUSM System Interconnect

Table 4-41. QSPI Clocks

This table describes the module clocking signals.

Module Instance	Module Clock Input	Source Clock Signal	Source	Default Freq	Description
QSPI0	QSPI0_ICLK (CLK)	SYS_CLK	PLL_CORE_CLK: HSDIV0_CLKOUT0	200 MHz	QSPI0 Interface Clock
	QSPI0_FCLK (SPI_CLK)	XTALCLK	External XTAL or RC Oscillator	25 MHz	QSPI0 Interface Clock
		EXT_REFCLK	External Reference Clock (EXT_REFCLK)	100 MHz	
		SYS_CLK	PLL_CORE_CLK: HSDIV0_CLKOUT0	200 MHz	
		DPLL_PER_HSDIV0_CLK OUT1	PLL_PER_CLK: HSDIV0_CLKOUT1	192 MHz	
		DPLL_CORE_HSDIV0_CL KOUT1	PLL_CORE_CLK: HSDIV0_CLKOUT1	400 MHz	
		RCCLK10M	Internal 10 MHz RC Oscillator (RCCLK10M)	10 MHz	
		XTALCLK	External XTAL	25 MHz	
		RCCLK10M	Internal 10 MHz RC Oscillator (RCCLK10M)	10 MHz	

Table 4-42. QSPI Resets

This table describes the module reset signals.

Module Instance	Module Reset Input	Source Reset Signal	Source	Description
QSPI0	QSPI0_RST (VBUSP_RSTn)	Warm Reset (MAIN_RST)	RCM + Warm Reset Sources	QSPI0 Asynchronous Reset

Table 4-43. QSPI Interrupt Requests

This table describes the module interrupt requests.

Module Instance	Module Interrupt Signal	Destination Interrupt Input	Destination	Type	Description
QSPI0	qspi0_intr	qspi0_intr_req	All R5FSS Cores ICSSM Core	Pulse	QSPI0 Interrupt

Table 4-44. QSPI DMA Requests

This table describes the module DMA requests.

Module Instance	Module DMA Event	Destination DMA Event Input	Destination	Type	Description
QSPI0	qspi0_intr	qspi0_intr_req	EDMA Crossbar (DMA_XBAR)	Pulse	QSPI0 DMA Event Request

Note

For more information on the interconnects, see the *System Interconnect* chapter.

For more information on power, reset, and clock management, see the corresponding sections within the *Device Configuration* chapter.

For more information on the device interrupt controllers, see the *Interrupt Controllers* chapter.

4.16 MCAN Integration

There are 4x MCAN modules integrated in the device. The diagram below provides a visual representation of the device integration details.

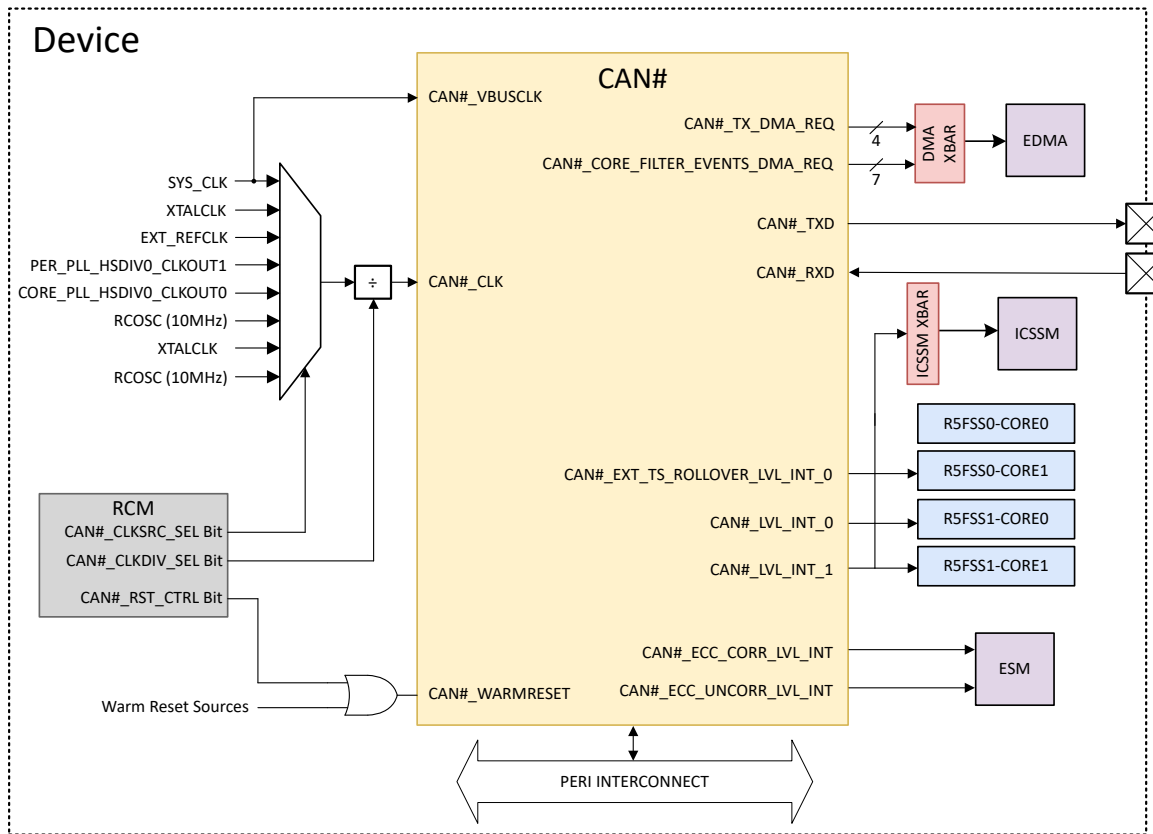

ADVANCE INFORMATION

The tables below summarize the device integration details of MCAN# (where # = 0 to 3).

Table 4-45. MCAN Device Integration

This table describes the module device integration details.

Module Instance	Device Allocation	SoC Interconnect
MCAN0	✓	Peripheral VBUSP Interconnect
MCAN1	✓	Peripheral VBUSP Interconnect
MCAN2	✓	Peripheral VBUSP Interconnect
MCAN3	✓	Peripheral VBUSP Interconnect

Table 4-46. MCAN Clocks

This table describes the module clocking signals.

Module Instance	Module Clock Input	Source Clock Signal	Source	Default Freq	Description
MCAN0	MCAN0_ICLK (VBUSP_CLK)	SYS_CLK	PLL_CORE_CLK:HSDIV0_CLKOUT0	200 MHz	MCAN0 Interface Clock
		MCAN0_FCLK (CAN_CLK)	XTALCLK	External Crystal (XTAL)	25 MHz
	EXT_REFCLK	External Reference Clock(EXT_REFCLK)	100 MHz		
	SYS_CLK	PLL_CORE_CLK:HSDIV0_CLKOUT0	200 MHz		
	DPLL_PER_HSDIV0_CLKOUT1	PLL_PER_CLK:HSDIV0_CLKOUT1	192 MHz		
	DPLL_CORE_HSDIV0_CLKOUT0	PLL_CORE_CLK:HSDIV0_CLKOUT1	500 MHz		
	RCCLK10M	Internal 10 MHz RC Oscillator(RCCLK10M)	10 MHz		
	XTALCLK	External Crystal (XTAL)	25 MHz		
	RCCLK10M	Internal 10 MHz RC Oscillator(RCCLK10M)	10 MHz		
MCAN1	MCAN1_ICLK (VBUSP_CLK)	SYS_CLK	PLL_CORE_CLK:HSDIV0_CLKOUT0	200 MHz	MCAN1 Interface Clock
		MCAN1_FCLK (CAN_CLK)	XTALCLK	External Crystal (XTAL)	25 MHz
	EXT_REFCLK	External Reference Clock(EXT_REFCLK)	100 MHz		
	SYS_CLK	PLL_CORE_CLK:HSDIV0_CLKOUT0	200 MHz		
	DPLL_PER_HSDIV0_CLKOUT1	PLL_PER_CLK:HSDIV0_CLKOUT1	192 MHz		
	DPLL_CORE_HSDIV0_CLKOUT0	PLL_CORE_CLK:HSDIV0_CLKOUT1	500 MHz		
	RCCLK10M	Internal 10 MHz RC Oscillator(RCCLK10M)	10 MHz		
	XTALCLK	External Crystal (XTAL)	25 MHz		
	RCCLK10M	Internal 10 MHz RC Oscillator(RCCLK10M)	10 MHz		

Table 4-46. MCAN Clocks (continued)

This table describes the module clocking signals.

Module Instance	Module Clock Input	Source Clock Signal	Source	Default Freq	Description
MCAN2	MCAN2_ICLK (VBUSP_CLK)	SYS_CLK	PLL_CORE_CLK:HSDIV0_CLKOUT0	200 MHz	MCAN2 Interface Clock
		MCAN2_FCLK (CAN_CLK)	XTALCLK	External Crystal (XTAL)	25 MHz
	EXT_REFCLK	External Reference Clock(EXT_REFCLK)	100 MHz		
	SYS_CLK	PLL_CORE_CLK:HSDIV0_CLKOUT0	200 MHz		
	DPLL_PER_HSDIV0_CLKOUT1	PLL_PER_CLK:HSDIV0_CLKOUT1	192 MHz		
	DPLL_CORE_HSDIV0_CLKOUT0	PLL_CORE_CLK:HSDIV0_CLKOUT1	500 MHz		
	RCCLK10M	Internal 10 MHz RC Oscillator(RCCLK10M)	10 MHz		
	XTALCLK	External Crystal (XTAL)	25 MHz		
	RCCLK10M	Internal 10 MHz RC Oscillator(RCCLK10M)	10 MHz		
MCAN3	MCAN3_ICLK (VBUSP_CLK)	SYS_CLK	PLL_CORE_CLK:HSDIV0_CLKOUT0	200 MHz	MCAN3 Interface Clock
		MCAN3_FCLK (CAN_CLK)	XTALCLK	External Crystal (XTAL)	25 MHz
	EXT_REFCLK	External Reference Clock(EXT_REFCLK)	100 MHz		
	SYS_CLK	PLL_CORE_CLK:HSDIV0_CLKOUT0	200 MHz		
	DPLL_PER_HSDIV0_CLKOUT1	PLL_PER_CLK:HSDIV0_CLKOUT1	192 MHz		
	DPLL_CORE_HSDIV0_CLKOUT0	PLL_CORE_CLK:HSDIV0_CLKOUT1	500 MHz		
	RCCLK10M	Internal 10 MHz RC Oscillator(RCCLK10M)	10 MHz		
	XTALCLK	External Crystal (XTAL)	25 MHz		
	RCCLK10M	Internal 10 MHz RC Oscillator(RCCLK10M)	10 MHz		

Table 4-47. MCAN Resets

This table describes the module reset signals.

Module Instance	Module Reset Input	Source Reset Signal	Source	Description
MCAN0	MCAN0_RST	Warm Reset (MOD_G_RST)	RCM + Warm Reset Sources	Asynchronous MCAN0 Module Reset
MCAN1	MCAN1_RST	Warm Reset (MOD_G_RST)	RCM + Warm Reset Sources	Asynchronous MCAN1 Module Reset
MCAN2	MCAN2_RST	Warm Reset (MOD_G_RST)	RCM + Warm Reset Sources	Asynchronous MCAN2 Module Reset
MCAN3	MCAN3_RST	Warm Reset (MOD_G_RST)	RCM + Warm Reset Sources	Asynchronous MCAN3 Module Reset

Table 4-48. MCAN Interrupt Requests

This table describes the module interrupt requests.

Module Instance	Module Interrupt Signal	Destination Interrupt Input	Destination	Type	Description	
MCAN0	MCAN0_INT_0	R5FSS0_CORE0_INTR_IN_27	R5FSS0-0	Level	MCAN0 Line 0 Interrupt Request	
		R5FSS0_CORE1_INTR_IN_27	R5FSS0-1			
		R5FSS1_CORE0_INTR_IN_27	R5FSS1-0			
		R5FSS1_CORE1_INTR_IN_27	R5FSS1-1			
		PRU_ICSS0_INTR_IN_40	PRU_ICSS			
	MCAN0_INT_1	MCAN0_INT_1	R5FSS0_CORE0_INTR_IN_28	R5FSS0-0	Level	MCAN0 Line 1 Interrupt Request
			R5FSS0_CORE1_INTR_IN_28	R5FSS0-1		
			R5FSS1_CORE0_INTR_IN_28	R5FSS1-0		
			R5FSS1_CORE1_INTR_IN_28	R5FSS1-1		
			PRU_ICSS0_INTR_IN_41	PRU_ICSS		
	MCAN0_EXT_TS_ROLLOVER_INT_0	MCAN0_EXT_TS_ROLLOVER_INT_0	R5FSS0_CORE0_INTR_IN_26	R5FSS0-0	Level	MCAN0 External TimeStamp Counter Rollover Interrupt
			R5FSS0_CORE1_INTR_IN_26	R5FSS0-1		
			R5FSS1_CORE0_INTR_IN_26	R5FSS1-0		
			R5FSS1_CORE1_INTR_IN_26	R5FSS1-1		
			PRU_ICSS0_INTR_IN_39	PRU_ICSS0		
	MCAN0_ECC_CORR_LVL_INT_0	ESM0_LVL_IN_2	ESM0	Level	MCAN0 ECC Correctable Error Interrupt	
	MCAN0_ECC_UNCORR_LVL_INT_0	ESM0_LVL_IN_3	ESM0	Level	MCAN0 ECC Uncorrectable Error Interrupt	
MCAN1	MCAN1_INT_0	R5FSS0_CORE0_INTR_IN_30	R5FSS0-0	Level	MCAN1 Line 0 Interrupt Request	
		R5FSS0_CORE1_INTR_IN_30	R5FSS0-1			
		R5FSS1_CORE0_INTR_IN_30	R5FSS1-0			
		R5FSS1_CORE1_INTR_IN_30	R5FSS1-1			
		PRU_ICSS0_INTR_IN_43	PRU_ICSS			
	MCAN1_INT_1	MCAN1_INT_1	R5FSS0_CORE0_INTR_IN_31	R5FSS0-0	Level	MCAN1 Line 1 Interrupt Request
			R5FSS0_CORE1_INTR_IN_31	R5FSS0-1		
			R5FSS1_CORE0_INTR_IN_31	R5FSS1-0		
			R5FSS1_CORE1_INTR_IN_31	R5FSS1-1		
			PRU_ICSS0_INTR_IN_44	PRU_ICSS		
	MCAN1_EXT_TS_ROLLOVER_INT_0	MCAN1_EXT_TS_ROLLOVER_INT_0	R5FSS0_CORE0_INTR_IN_29	R5FSS0-0	Level	MCAN1 External TimeStamp Counter Rollover Interrupt
			R5FSS0_CORE1_INTR_IN_29	R5FSS0-1		
			R5FSS1_CORE0_INTR_IN_29	R5FSS1-0		
			R5FSS1_CORE1_INTR_IN_29	R5FSS1-1		
			PRU_ICSS0_INTR_IN_42	PRU_ICSS		
	MCAN1_ECC_UNCORR_LVL_INT_0	ESM0_LVL_IN_4	ESM0	Level	MCAN1 ECC Uncorrectable Error Interrupt	
	MCAN1_ECC_CORR_LVL_INT_0	ESM0_LVL_IN_5	ESM0	Level	MCAN1 ECC Correctable Error Interrupt	

Table 4-48. MCAN Interrupt Requests (continued)

This table describes the module interrupt requests.

Module Instance	Module Interrupt Signal	Destination Interrupt Input	Destination	Type	Description	
MCAN2	MCAN2_INT_0	R5FSS0_CORE1_INTR_IN_33	R5FSS0-0	Level	MCAN1 Line 0 Interrupt Request	
		R5FSS0_CORE1_INTR_IN_33	R5FSS0-1			
		R5FSS1_CORE0_INTR_IN_33	R5FSS1-0			
		R5FSS1_CORE1_INTR_IN_33	R5FSS1-1			
		PRU_ICSS0_INTR_IN_46	PRU_ICSS			
	MCAN2_INT_1	R5FSS0_CORE0_INTR_IN_34	R5FSS0-0	Level	MCAN2 Line 1 Interrupt Request	
		R5FSS0_CORE1_INTR_IN_34	R5FSS0-1			
		R5FSS1_CORE0_INTR_IN_34	R5FSS1-0			
		R5FSS1_CORE1_INTR_IN_34	R5FSS1-1			
		PRU_ICSS0_INTR_IN_47	PRU_ICSS			
	MCAN2_EXT_TS_ROLLOVER_INT_0	R5FSS0_CORE0_INTR_IN_32	R5FSS0-0	Level	MCAN2 External TimeStamp Counter Rollover Interrupt	
		R5FSS0_CORE1_INTR_IN_32	R5FSS0-1			
		R5FSS1_CORE0_INTR_IN_32	R5FSS1-0			
		R5FSS1_CORE1_INTR_IN_32	R5FSS1-1			
		PRU_ICSS0_INTR_IN_45	PRU_ICSS			
	MCAN2_ECC_UNCORR_LVL_INT_0	ESM0_LVL_IN_6	ESM0	Level	MCAN2 ECC Uncorrectable Error Interrupt	
	MCAN2_ECC_CORR_LVL_INT_0	ESM0_LVL_IN_7	ESM0	Level	MCAN2 ECC Correctable Error Interrupt	
	MCAN3	MCAN3_INT_0	R5FSS0_CORE0_INTR_IN_36	R5FSS0-0	Level	MCAN3 Line 0 Interrupt Request
			R5FSS0_CORE1_INTR_IN_36	R5FSS0-1		
			R5FSS1_CORE0_INTR_IN_36	R5FSS1-0		
R5FSS1_CORE1_INTR_IN_36			R5FSS1-1			
PRU_ICSS0_INTR_IN_49			PRU_ICSS			
MCAN3_INT_1		R5FSS0_CORE0_INTR_IN_37	R5FSS0-0	Level	MCAN3 Line 1 Interrupt Request	
		R5FSS0_CORE1_INTR_IN_37	R5FSS0-1			
		R5FSS1_CORE0_INTR_IN_37	R5FSS1-0			
		R5FSS1_CORE1_INTR_IN_37	R5FSS1-1			
		PRU_ICSS0_INTR_IN_50	PRU_ICSS			
MCAN3_EXT_TS_ROLLOVER_INT_0		R5FSS0_CORE0_INTR_IN_35	R5FSS0-0	Level	MCAN3 External TimeStamp Counter Rollover Interrupt	
		R5FSS0_CORE1_INTR_IN_35	R5FSS0-1			
		R5FSS1_CORE0_INTR_IN_35	R5FSS1-0			
		R5FSS1_CORE1_INTR_IN_35	R5FSS1-1			
		PRU_ICSS0_INTR_IN_48	PRU_ICSS			
MCAN3_ECC_UNCORR_LVL_INT_0		ESM0_LVL_IN_8	ESM0	Level	MCAN3 ECC Uncorrectable Error Interrupt	
MCAN3_ECC_CORR_LVL_INT_0		ESM0_LVL_IN_9	ESM0	Level	MCAN3 ECC Correctable Error Interrupt	

Table 4-49. MCAN DMA Requests

This table describes the module DMA requests.

Module Instance	Module DMA Event	Destination DMA Event Input	Destination	Type	Description
MCAN0	MCAN0_FE_INTR_0	EDMA_XBAR_147	EDMA	Pulse	MCAN0 Receive Filter Event 0 DMA Request
	MCAN0_FE_INTR_1	EDMA_XBAR_148	EDMA	Pulse	MCAN0 Receive Filter Event 1 DMA Request
	MCAN0_FE_INTR_2	EDMA_XBAR_149	EDMA	Pulse	MCAN0 Receive Filter Event 2 DMA Request
	MCAN0_FE_INTR_3	EDMA_XBAR_150	EDMA	Pulse	MCAN0 Receive Filter Event 3 DMA Request
	MCAN0_FE_INTR_4	EDMA_XBAR_151	EDMA	Pulse	MCAN0 Receive Filter Event 4 DMA Request
	MCAN0_FE_INTR_5	EDMA_XBAR_152	EDMA	Pulse	MCAN0 Receive Filter Event 5 DMA Request
	MCAN0_FE_INTR_6	EDMA_XBAR_153	EDMA	Pulse	MCAN0 Receive Filter Event 6 DMA Request
	MCAN0_TXDMA_0	EDMA_XBAR_74	EDMA	Pulse	MCAN0 Transmit Core DMA Request 0
	MCAN0_TXDMA_1	EDMA_XBAR_75	EDMA	Pulse	MCAN0 Transmit Core DMA Request 1
	MCAN0_TXDMA_2	EDMA_XBAR_76	EDMA	Pulse	MCAN0 Transmit Core DMA Request 2
	MCAN0_TXDMA_3	EDMA_XBAR_77	EDMA	Pulse	MCAN0 Transmit Core DMA Request 3

Table 4-49. MCAN DMA Requests (continued)

This table describes the module DMA requests.

Module Instance	Module DMA Event	Destination DMA Event Input	Destination	Type	Description
MCAN1	MCAN1_FE_INTR_0	EDMA_XBAR_154	EDMA	Pulse	MCAN1 Receive Filter Event 0 DMA Request
	MCAN1_FE_INTR_1	EDMA_XBAR_155	EDMA	Pulse	MCAN1 Receive Filter Event 1 DMA Request
	MCAN1_FE_INTR_2	EDMA_XBAR_156	EDMA	Pulse	MCAN1 Receive Filter Event 2 DMA Request
	MCAN1_FE_INTR_3	EDMA_XBAR_157	EDMA	Pulse	MCAN1 Receive Filter Event 3 DMA Request
	MCAN1_FE_INTR_4	EDMA_XBAR_158	EDMA	Pulse	MCAN1 Receive Filter Event 4 DMA Request
	MCAN1_FE_INTR_5	EDMA_XBAR_159	EDMA	Pulse	MCAN1 Receive Filter Event 5 DMA Request
	MCAN1_FE_INTR_6	EDMA_XBAR_160	EDMA	Pulse	MCAN1 Receive Filter Event 6 DMA Request
	MCAN1_TXDMA_0	EDMA_XBAR_78	EDMA	Pulse	MCAN1 Transmit Core DMA Request 0
	MCAN1_TXDMA_1	EDMA_XBAR_79	EDMA	Pulse	MCAN1 Transmit Core DMA Request 1
	MCAN1_TXDMA_2	EDMA_XBAR_80	EDMA	Pulse	MCAN1 Transmit Core DMA Request 2
	MCAN1_TXDMA_3	EDMA_XBAR_81	EDMA	Pulse	MCAN1 Transmit Core DMA Request 3

Table 4-49. MCAN2 DMA Requests (continued)

This table describes the module DMA requests.

Module Instance	Module DMA Event	Destination DMA Event Input	Destination	Type	Description
MCAN2	MCAN2_FE_INTR_0	EDMA_XBAR_161	EDMA	Pulse	MCAN2 Receive Filter Event 0 DMA Request
	MCAN2_FE_INTR_1	EDMA_XBAR_162	EDMA	Pulse	MCAN2 Receive Filter Event 1 DMA Request
	MCAN2_FE_INTR_2	EDMA_XBAR_163	EDMA	Pulse	MCAN2 Receive Filter Event 2 DMA Request
	MCAN2_FE_INTR_3	EDMA_XBAR_164	EDMA	Pulse	MCAN2 Receive Filter Event 3 DMA Request
	MCAN2_FE_INTR_4	EDMA_XBAR_165	EDMA	Pulse	MCAN2 Receive Core Filter Event 4 DMA Request
	MCAN2_FE_INTR_5	EDMA_XBAR_166	EDMA	Pulse	MCAN2 Receive Filter Event 5 DMA Request
	MCAN2_FE_INTR_6	EDMA_XBAR_167	EDMA	Pulse	MCAN2 Receiver Filter Event 6 DMA Request
	MCAN2_TXDMA_0	EDMA_XBAR_82	EDMA	Pulse	MCAN2 Transmit Core DMA Request 0
	MCAN2_TXDMA_1	EDMA_XBAR_83	EDMA	Pulse	MCAN2 Transmit Core DMA Request 1
	MCAN2_TXDMA_2	EDMA_XBAR_84	EDMA	Pulse	MCAN2 Transmit Core DMA Request 2
	MCAN2_TXDMA_3	EDMA_XBAR_85	EDMA	Pulse	MCAN2 Transmit Core DMA Request 3

Table 4-49. MCAN DMA Requests (continued)

This table describes the module DMA requests.

Module Instance	Module DMA Event	Destination DMA Event Input	Destination	Type	Description
MCAN3	MCAN3_FE_INTR_0	EDMA_XBAR_168	EDMA	Pulse	MCAN3 Receive Filter Event 0 DMA Request
	MCAN3_FE_INTR_1	EDMA_XBAR_169	EDMA	Pulse	MCAN3 Receive Filter Event 1 DMA Request
	MCAN3_FE_INTR_2	EDMA_XBAR_170	EDMA	Pulse	MCAN3 Receive Filter Event 2 DMA Request
	MCAN3_FE_INTR_3	EDMA_XBAR_171	EDMA	Pulse	MCAN3 Receive Filter Event 3 DMA Request
	MCAN3_FE_INTR_4	EDMA_XBAR_172	EDMA	Pulse	MCAN3 Receive Filter Event 4 DMA Request
	MCAN3_FE_INTR_5	EDMA_XBAR_173	EDMA	Pulse	MCAN3 Receive Filter Event 5 DMA Request
	MCAN3_FE_INTR_6	EDMA_XBAR_174	EDMA	Pulse	MCAN3 Receive Filter Event 6 DMA Request
	MCAN3_TXDMA_0	EDMA_XBAR_86	EDMA	Pulse	MCAN3 Transmit Core DMA Request 0
	MCAN3_TXDMA_1	EDMA_XBAR_87	EDMA	Pulse	MCAN3 Transmit Core DMA Request 1
	MCAN3_TXDMA_2	EDMA_XBAR_88	EDMA	Pulse	MCAN3 Transmit Core DMA Request 2
	MCAN3_TXDMA_3	EDMA_XBAR_89	EDMA	Pulse	MCAN3 Transmit Core DMA Request 3

Note

For more information on the interconnects, see the *System Interconnect* chapter.

For more information on power, reset, and clock management, see the corresponding sections within the *Device Configuration* chapter.

For more information on the device interrupt controllers, see the *Interrupt Controllers* chapter.

There are 5x LIN modules integrated in the device. The diagram below provides a visual representation of the device integration details.

= 0 to 4

Figure 4-20. LIN Integration

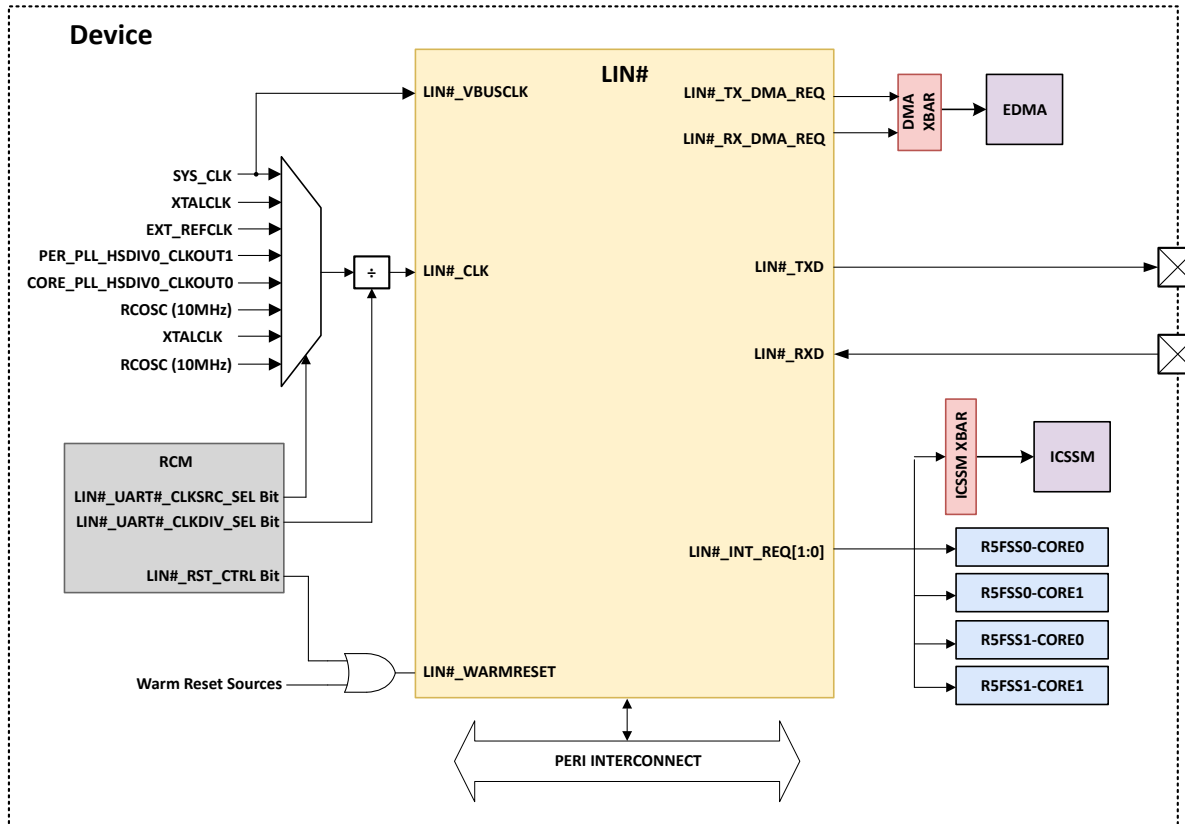

ADVANCE INFORMATION

The tables below summarize the device integration details of LIN# (where # = 5).

Table 4-50. LIN Device Integration

This table describes the LIN device integration details.

LIN Instance	Device Allocation	SoC Interconnect
LIN0	✓	Peripheral VBUSP Interconnect
LIN1	✓	Peripheral VBUSP Interconnect
LIN2	✓	Peripheral VBUSP Interconnect
LIN3	✓	Peripheral VBUSP Interconnect
LIN4	✓	Peripheral VBUSP Interconnect

Table 4-51. LIN Clocks

This table describes the LIN clocking signals.

LIN Instance	LIN Clock Input	Source Clock Signal	Source	Default Freq	Description
LIN0	LIN0_ICLK (VBUSP_CLK)	SYS_CLK	PLL_CORE_CLK: HSDIV0_CLKOUT0	200 MHz	LIN0 Interface Clock (LIN0_CLK should be running for register access)
	LIN0_FCLK (LIN_CLK)	XTALCLK	External XTAL	25 MHz	LIN0 Functional Clock
		EXT_REFCLK	External Reference Clock (EXT_REFCLK)	100 MHz	
		SYS_CLK	PLL_CORE_CLK: HSDIV0_CLKOUT0	200 MHz	
		DPLL_PER_HSDIV0_CLK OUT1	PLL_PER_CLK: HSDIV0_CLKOUT1	192 MHz	
		DPLL_CORE_HSDIV0_CLK KOUT0	PLL_CORE_CLK: HSDIV0_CLKOUT0	400 MHz	
		RCCLK10M	Internal 10MHz RC Oscillator (RCCLK10M)	10 MHz	
		XTALCLK	External XTAL	25 MHz	
		DPLL_PER_HSDIV0_CLK OUT0	PLL_PER_CLK:HSDIV0_C LKOUT0	160 MHz	
LIN1	LIN1_ICLK (VBUSP_CLK)	SYS_CLK	PLL_CORE_CLK: HSDIV0_CLKOUT0	200 MHz	LIN1 Interface Clock (LIN1_CLK should be running for register access)
	LIN1_FCLK (LIN_CLK)	XTALCLK	External XTAL	25 MHz	LIN1 Functional Clock
		EXT_REFCLK	External Reference Clock (EXT_REFCLK)	100 MHz	
		SYS_CLK	PLL_CORE_CLK: HSDIV0_CLKOUT0	200 MHz	
		DPLL_PER_HSDIV0_CLK OUT1	PLL_PER_CLK: HSDIV0_CLKOUT1	192 MHz	
		DPLL_CORE_HSDIV0_CLK KOUT0	PLL_CORE_CLK: HSDIV0_CLKOUT0	400 MHz	
		RCCLK10M	Internal 10MHz RC Oscillator (RCCLK10M)	10 MHz	
		XTALCLK	External XTAL	25 MHz	
		DPLL_PER_HSDIV0_CLK OUT0	PLL_PER_CLK:HSDIV0_C LKOUT0	160 MHz	

Table 4-51. LIN Clocks (continued)

This table describes the LIN clocking signals.

LIN Instance	LIN Clock Input	Source Clock Signal	Source	Default Freq	Description
LIN2	LIN2_ICLK (VBUSP_CLK)	SYS_CLK	PLL_CORE_CLK: HSDIV0_CLKOUT0	200 MHz	LIN2 Interface Clock (LIN2_CLK should be running for register access)
	LIN2_FCLK (LIN_CLK)	XTALCLK	External XTAL	25 MHz	LIN2 Functional Clock
		EXT_REFCLK	External Reference Clock (EXT_REFCLK)	100 MHz	
		SYS_CLK	PLL_CORE_CLK: HSDIV0_CLKOUT0	200 MHz	
		DPLL_PER_HSDIV0_CLK OUT1	PLL_PER_CLK: HSDIV0_CLKOUT1	192 MHz	
		DPLL_CORE_HSDIV0_CL KOUT0	PLL_CORE_CLK: HSDIV0_CLKOUT0	400 MHz	
		RCCLK10M	Internal 10MHz RC Oscillator (RCCLK10M)	10 MHz	
		XTALCLK	External XTAL	25 MHz	
DPLL_PER_HSDIV0_CLK OUT0	PLL_PER_CLK:HSDIV0_C LKOUT0	160 MHz			
LIN3	LIN3_ICLK (VBUSP_CLK)	SYS_CLK	PLL_CORE_CLK: HSDIV0_CLKOUT0	200 MHz	LIN3 Interface Clock (LIN3_CLK should be running for register access)
	LIN3_FCLK (LIN_CLK)	XTALCLK	External XTAL	25 MHz	LIN3 Functional Clock
		EXT_REFCLK	External Reference Clock (EXT_REFCLK)	100 MHz	
		SYS_CLK	PLL_CORE_CLK: HSDIV0_CLKOUT0	200 MHz	
		DPLL_PER_HSDIV0_CLK OUT1	PLL_PER_CLK: HSDIV0_CLKOUT1	192 MHz	
		DPLL_CORE_HSDIV0_CL KOUT0	PLL_CORE_CLK: HSDIV0_CLKOUT0	400 MHz	
		RCCLK10M	Internal 10MHz RC Oscillator (RCCLK10M)	10 MHz	
		XTALCLK	External XTAL	25 MHz	
DPLL_PER_HSDIV0_CLK OUT0	PLL_PER_CLK:HSDIV0_C LKOUT0	160 MHz			

Table 4-51. LIN Clocks (continued)

This table describes the LIN clocking signals.

LIN Instance	LIN Clock Input	Source Clock Signal	Source	Default Freq	Description
LIN4	LIN4_ICLK (VBUSP_CLK)	SYS_CLK	PLL_CORE_CLK: HSDIV0_CLKOUT0	200 MHz	LIN4 Interface Clock (LIN4_CLK should be running for register access)
	LIN4_FCLK (LIN_CLK)	XTALCLK	External XTAL	25 MHz	LIN4 Functional Clock
		EXT_REFCLK	External Reference Clock (EXT_REFCLK)	100 MHz	
		SYS_CLK	PLL_CORE_CLK: HSDIV0_CLKOUT0	200 MHz	
		DPLL_PER_HSDIV0_CLK OUT1	PLL_PER_CLK: HSDIV0_CLKOUT1	192 MHz	
		DPLL_CORE_HSDIV0_CL KOUT0	PLL_CORE_CLK: HSDIV0_CLKOUT0	400 MHz	
		RCCLK10M	Internal 10MHz RC Oscillator (RCCLK10M)	10 MHz	
		XTALCLK	External XTAL	25 MHz	
DPLL_PER_HSDIV0_CLK OUT0	PLL_PER_CLK:HSDIV0_C LKOUT0	160 MHz			

Table 4-52. LIN Resets

This table describes the LIN reset signals.

LIN Instance	LIN Reset Input	Source Reset Signal	Source	Description
LIN0	LIN0_RST (VBUSP_RSTn)	Warm Reset (MOD_G_RST)	RCM + Warm Reset Sources	LIN0 Asynchronous Reset
LIN1	LIN1_RST (VBUSP_RSTn)	Warm Reset (MOD_G_RST)	RCM + Warm Reset Sources	LIN1 Asynchronous Reset
LIN2	LIN2_RST (VBUSP_RSTn)	Warm Reset (MOD_G_RST)	RCM + Warm Reset Sources	LIN2 Asynchronous Reset
LIN3	LIN3_RST (VBUSP_RSTn)	Warm Reset (MOD_G_RST)	RCM + Warm Reset Sources	LIN3 Asynchronous Reset
LIN4	LIN4_RST (VBUSP_RSTn)	Warm Reset (MOD_G_RST)	RCM + Warm Reset Sources	LIN4 Asynchronous Reset

Table 4-53. LIN Interrupt Requests

This table describes the LIN interrupt requests.

LIN Instance	LIN Interrupt Signal	Destination Interrupt Input	Destination	Type	Description
LIN0	LIN0_INT_req_0	LIN0_INT_req_0	ALL R5FSS Cores, ICSSMXBAR	Pulse	LIN0 Event Interrupts
	LIN0_INT_req_1	LIN0_INT_req_1			
LIN1	LIN1_INT_req_0	LIN1_INT_req_0	ALL R5FSS Cores, ICSSMXBAR	Pulse	LIN1 Event Interrupts
	LIN1_INT_req_1	LIN1_INT_req_1			
LIN2	LIN2_INT_req_0	LIN2_INT_req_0	ALL R5FSS Cores, ICSSMXBAR	Pulse	LIN2 Event Interrupts
	LIN2_INT_req_1	LIN2_INT_req_1			

Table 4-53. LIN Interrupt Requests (continued)

This table describes the LIN interrupt requests.

LIN Instance	LIN Interrupt Signal	Destination Interrupt Input	Destination	Type	Description
LIN3	LIN3_INT_req_0	LIN3_INT_req_0	ALL R5FSS Cores, ICSSMXBAR	Pulse	LIN3 Event Interrupts
	LIN3_INT_req_1	LIN3_INT_req_1			
LIN4	LIN4_INT_req_0	LIN4_INT_req_0	ALL R5FSS Cores, ICSSMXBAR	Pulse	LIN4 Event Interrupts
	LIN4_INT_req_1	LIN4_INT_req_1			

Table 4-54. LIN DMA Requests

This table describes the LIN DMA requests.

LIN Instance	LIN DMA Event	Destination DMA Event Input	Destination	Type	Description
LIN0	LIN0_TX_DMA_REQ	LIN0_tx_dma_req	EDMA Crossbar (DMA_XBAR)	Pulse	LIN0 TX DMA Request
	LIN0_RX_DMA_REQ	LIN0_rx_dma_req			LIN0 RX DMA Request
LIN1	LIN1_TX_DMA_REQ	LIN1_tx_dma_req	EDMA Crossbar (DMA_XBAR)	Pulse	LIN1 TX DMA Request
	LIN1_RX_DMA_REQ	LIN1_rx_dma_req			LIN1 RX DMA Request
LIN2	LIN2_TX_DMA_REQ	LIN2_tx_dma_req	EDMA Crossbar (DMA_XBAR)	Pulse	LIN2 TX DMA Request
	LIN2_RX_DMA_REQ	LIN2_rx_dma_req			LIN2 RX DMA Request
LIN3	LIN3_TX_DMA_REQ	LIN3_tx_dma_req	EDMA Crossbar (DMA_XBAR)	Pulse	LIN3 TX DMA Request
	LIN3_RX_DMA_REQ	LIN3_rx_dma_req			LIN3 RX DMA Request
LIN4	LIN4_TX_DMA_REQ	LIN4_tx_dma_req	EDMA Crossbar (DMA_XBAR)	Pulse	LIN4 TX DMA Request
	LIN4_RX_DMA_REQ	LIN4_rx_dma_req			LIN4 RX DMA Request

Note

For more information on the interconnects, see the *System Interconnect* chapter.

For more information on power, reset, and clock management, see the corresponding sections within the *Device Configuration* chapter.

For more information on the device interrupt controllers, see the *Interrupt Controllers* chapter.

4.17 RTI Integration

There are 4x RTI modules integrated in the device. The diagram and tables below show the device integration details.

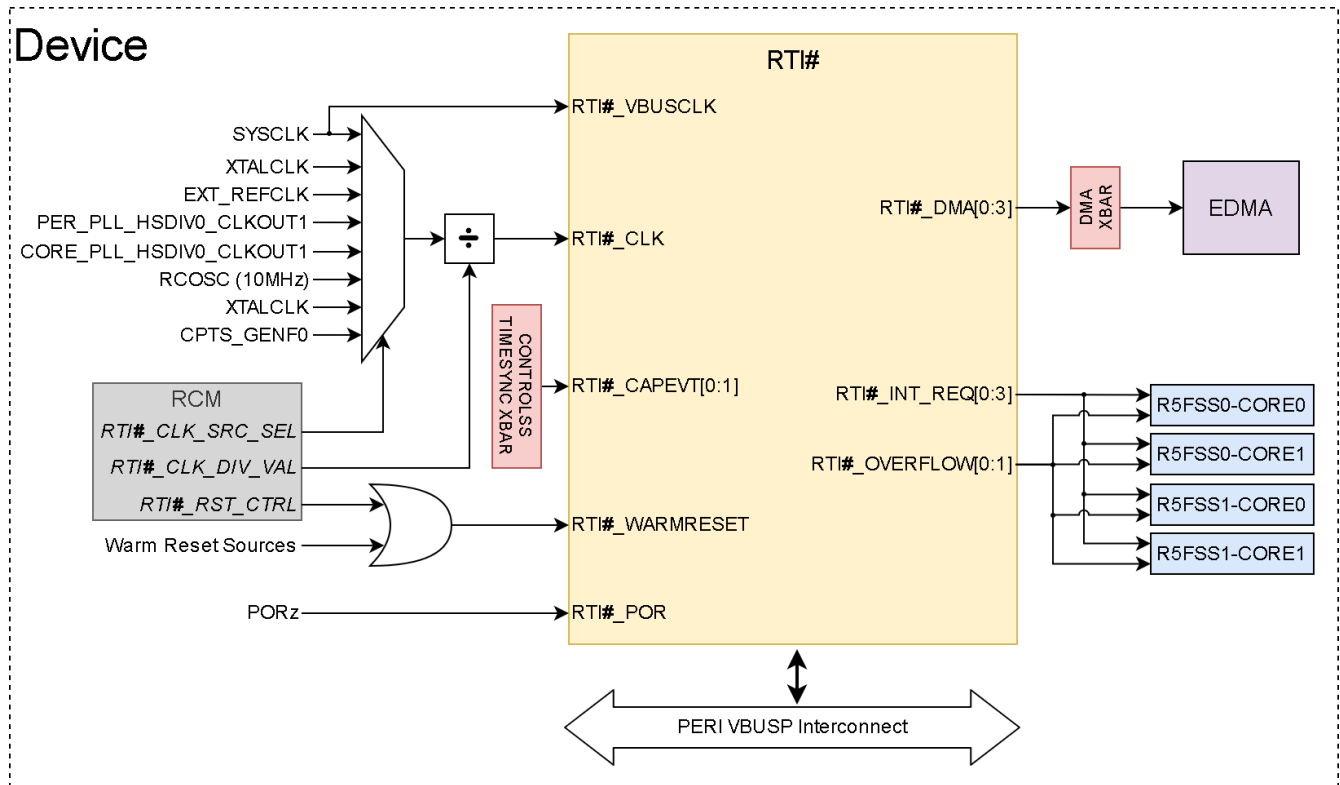

Figure 4-21. RTI Integration

The tables below summarize the integration of RTI# (where # = 0, 1, 2, 3) in the device.

Each RTI# instance is supplied by dedicated RTICLK# mux.

Table 4-55. RTI Device Integration

This table describes the module device integration details.

Module Instance	Device Allocation	SoC Interconnect
RTI0	✓	VBUSP CORE Interconnect
RTI1	✓	VBUSP CORE Interconnect
RTI2	✓	VBUSP CORE Interconnect
RTI3	✓	VBUSP CORE Interconnect

ADVANCE INFORMATION

Table 4-56. RTI Clocks

This table describes the module clocking signals.

Module Instance	Module Clock Input	Source Clock Signal	Source	Default Freq	Description
RTI0	RTI0_ICLK (VBUSP_CLK)	SYS_CLK	PLL_CORE_CLK: HSDIV0_CLKOUT0	200 MHz	RTI0 VBUSP Interface Clock
	RTI0_FCLK (RTI_CLK)	XTALCLK	External XTAL	25 MHz	RTI0 Functional Clock
		EXT_REFCLK	External Reference Clock (EXT_REFCLK)	100 MHz	
		SYS_CLK	PLL_CORE_CLK: HSDIV0_CLKOUT0	200 MHz	
		DPLL_PER_HSDIV0_CLK OUT1	PLL_PER_CLK: HSDIV0_CLKOUT1	192 MHz	
		DPLL_CORE_HSDIV0_CLK OUT1	PLL_CORE_CLK: HSDIV0_CLKOUT1	500 MHz	
		RCCLK10M	Internal 10 MHz RC Oscillator (RCCLK10M)	10 MHz	
		XTALCLK	External XTAL	25 MHz	
CTPS_GENF0	CPSW3G CPTS GENF0 Clock	50 MHz			
RTI1	RTI1_ICLK (VBUSP_CLK)	SYS_CLK	PLL_CORE_CLK: HSDIV0_CLKOUT0	200 MHz	RTI1 VBUSP Interface Clock
	RTI1_FCLK (RTI_CLK)	XTALCLK	External XTAL	25 MHz	RTI1 Functional Clock
		EXT_REFCLK	External Reference Clock (EXT_REFCLK)	100 MHz	
		SYS_CLK	PLL_CORE_CLK: HSDIV0_CLKOUT0	200 MHz	
		DPLL_PER_HSDIV0_CLK OUT1	PLL_PER_CLK: HSDIV0_CLKOUT1	192 MHz	
		DPLL_CORE_HSDIV0_CLK OUT1	PLL_CORE_CLK: HSDIV0_CLKOUT1	500 MHz	
		RCCLK10M	Internal 10 MHz RC Oscillator (RCCLK10M)	10 MHz	
		XTALCLK	External XTAL	25 MHz	
CTPS_GENF0	CPSW3G CPTS GENF0 Clock	50 MHz			

Table 4-56. RTI Clocks (continued)

This table describes the module clocking signals.

Module Instance	Module Clock Input	Source Clock Signal	Source	Default Freq	Description
RTI2	RTI2_ICLK (VBUSP_CLK)	SYS_CLK	PLL_CORE_CLK: HSDIV0_CLKOUT0	200 MHz	RTI2 VBUSP Interface Clock
	RTI2_FCLK (RTI_CLK)	XTALCLK	External XTAL	25 MHz	RTI2 Functional Clock
		EXT_REFCLK	External Reference Clock (EXT_REFCLK)	100 MHz	
		SYS_CLK	PLL_CORE_CLK: HSDIV0_CLKOUT0	200 MHz	
		DPLL_PER_HSDIV0_CLK OUT1	PLL_PER_CLK: HSDIV0_CLKOUT1	192 MHz	
		DPLL_CORE_HSDIV0_CLK KOUT1	PLL_CORE_CLK: HSDIV0_CLKOUT1	500 MHz	
		RCCLK10M	Internal 10 MHz RC Oscillator (RCCLK10M)	10 MHz	
		XTALCLK	External XTAL	25 MHz	
CTPS_GENF0	CPSW3G CPTS GENF0 Clock	50 MHz			
RTI3	RTI3_ICLK (VBUSP_CLK)	SYS_CLK	PLL_CORE_CLK: HSDIV0_CLKOUT0	200 MHz	RTI3 VBUSP Interface Clock
	RTI3_FCLK (RTI_CLK)	XTALCLK	External XTAL	25 MHz	RTI3 Functional Clock
		EXT_REFCLK	External Reference Clock (EXT_REFCLK)	100 MHz	
		SYS_CLK	PLL_CORE_CLK: HSDIV0_CLKOUT0	200 MHz	
		DPLL_PER_HSDIV0_CLK OUT1	PLL_PER_CLK: HSDIV0_CLKOUT1	192 MHz	
		DPLL_CORE_HSDIV0_CLK KOUT1	PLL_CORE_CLK: HSDIV0_CLKOUT1	500 MHz	
		RCCLK10M	Internal 10 MHz RC Oscillator (RCCLK10M)	10 MHz	
		XTALCLK	External XTAL	25 MHz	
CTPS_GENF0	CPSW3G CPTS GENF0 Clock	50 MHz			

Table 4-57. RTI Resets

This table describes the module reset signals.

Module Instance	Module Reset Input	Source Reset Signal	Source	Description
RTI0	RTI0_RST	Warm Reset (MOD_G_RST)	RCM + Warm Reset Sources	RTI0 Asynchronous Reset
	RTI0_POR_RST	POR Reset (MOD_POR_RST)	Device Power-On Reset	RTI0 Power-On Reset

Table 4-57. RTI Resets (continued)

This table describes the module reset signals.

Module Instance	Module Reset Input	Source Reset Signal	Source	Description
RTI1	RTI1_RST	Warm Reset (MOD_G_RST)	RCM + Warm Reset Sources	RTI1 Asynchronous Reset
	RTI1_POR_RST	POR Reset (MOD_POR_RST)	Device Power-On Reset	RTI1 Power-On Reset
RTI2	RTI2_RST	Warm Reset (MOD_G_RST)	RCM + Warm Reset Sources	RTI2 Asynchronous Reset
	RTI2_POR_RST	POR Reset (MOD_POR_RST)	Device Power-On Reset	RTI2 Power-On Reset
RTI3	RTI3_RST	Warm Reset (MOD_G_RST)	RCM + Warm Reset Sources	RTI3 Asynchronous Reset
	RTI3_POR_RST	POR Reset (MOD_POR_RST)	Device Power-On Reset	RTI3 Power-On Reset

Table 4-58. RTI Interrupt Requests

This table describes the module interrupt requests.

Module Instance	Module Interrupt Signal	Destination Interrupt Input	Destination	Type	Description
RTI0	RTI0_INT_REQ_0	RTI0_INT_REQ_0	ALL R5FSS Cores	Level	RTI0 Status Event Interrupt
	RTI0_INT_REQ_1	RTI0_INT_REQ_1			
	RTI0_INT_REQ_2	RTI0_INT_REQ_2			
	RTI0_INT_REQ_3	RTI0_INT_REQ_3			
	RTI0_OVL_REQ_0	RTI0_OVERFLOW_LEVEL_0			RTI0 Counter Overflow Event Interrupt
	RTI0_OVL_REQ_1	RTI0_OVERFLOW_LEVEL_1			
RTI1	RTI1_INT_REQ_0	RTI1_INT_REQ_0	ALL R5FSS Cores	Level	RTI1 Status Event Interrupt
	RTI1_INT_REQ_1	RTI1_INT_REQ_1			
	RTI1_INT_REQ_2	RTI1_INT_REQ_2			
	RTI1_INT_REQ_3	RTI1_INT_REQ_3			
	RTI1_OVL_REQ_0	RTI1_OVERFLOW_LEVEL_0			RTI1 Counter Overflow Event Interrupt
	RTI1_OVL_REQ_1	RTI1_OVERFLOW_LEVEL_1			
RTI2	RTI2_INT_REQ_0	RTI2_INT_REQ_0	ALL R5FSS Cores	Level	RTI2 Status Event Interrupt
	RTI2_INT_REQ_1	RTI2_INT_REQ_1			
	RTI2_INT_REQ_2	RTI2_INT_REQ_2			
	RTI2_INT_REQ_3	RTI2_INT_REQ_3			
	RTI2_OVL_REQ_0	RTI2_OVERFLOW_LEVEL_0			RTI2 Counter Overflow Event Interrupt
	RTI2_OVL_REQ_1	RTI2_OVERFLOW_LEVEL_1			
RTI3	RTI3_INT_REQ_0	RTI3_INT_REQ_0	ALL R5FSS Cores	Level	RTI3 Status Event Interrupt
	RTI3_INT_REQ_1	RTI3_INT_REQ_1			
	RTI3_INT_REQ_2	RTI3_INT_REQ_2			
	RTI3_INT_REQ_3	RTI3_INT_REQ_3			
	RTI3_OVL_REQ_0	RTI3_OVERFLOW_LEVEL_0			RTI3 Counter Overflow Event Interrupt
	RTI3_OVL_REQ_1	RTI3_OVERFLOW_LEVEL_1			

Table 4-59. RTI DMA Requests

This table describes the module DMA requests.

Module Instance	Module DMA Event	Destination DMA Event Input	Destination	Type	Description				
RTI0	RTI0_DMA_0	RTI0_DMA_REQ_0	EDMA Crossbar (EDMA_XBAR)	Level	RTI0 DMA Request				
	RTI0_DMA_1	RTI0_DMA_REQ_1							
	RTI0_DMA_2	RTI0_DMA_REQ_2							
	RTI0_DMA_3	RTI0_DMA_REQ_3							
RTI1	RTI1_DMA_0	RTI1_DMA_REQ_0			EDMA Crossbar (EDMA_XBAR)	Level	RTI1 DMA Request		
	RTI1_DMA_1	RTI1_DMA_REQ_1							
	RTI1_DMA_2	RTI1_DMA_REQ_2							
	RTI1_DMA_3	RTI1_DMA_REQ_3							
RTI2	RTI2_DMA_0	RTI2_DMA_REQ_0					EDMA Crossbar (EDMA_XBAR)	Level	RTI2 DMA Request
	RTI2_DMA_1	RTI2_DMA_REQ_1							
	RTI2_DMA_2	RTI2_DMA_REQ_2							
	RTI2_DMA_3	RTI2_DMA_REQ_3							
RTI3	RTI3_DMA_0	RTI3_DMA_REQ_0	EDMA Crossbar (EDMA_XBAR)	Level					RTI3 DMA Request
	RTI3_DMA_1	RTI3_DMA_REQ_1							
	RTI3_DMA_2	RTI3_DMA_REQ_2							
	RTI3_DMA_3	RTI3_DMA_REQ_3							

Table 4-60. RTI Capture Events

This table describes the module capture events.

Module Instance	Module Capture Event Input	Capture Event Source Signal	Source	Type	Description						
RTI0	RTI0_CAPEVT_0	SoC_TIMESYNC_XBAROUT_2	SoC Time Sync Crossbar (TIMESYNC_XBAR)	Level	RTI0 Counter Capture Input Event						
	RTI0_CAPEVT_1	SoC_TIMESYNC_XBAROUT_3									
RTI1	RTI1_CAPEVT_0	SoC_TIMESYNC_XBAROUT_4			SoC Time Sync Crossbar (TIMESYNC_XBAR)	Level	RTI1 Counter Capture Input Event				
	RTI1_CAPEVT_1	SoC_TIMESYNC_XBAROUT_5									
RTI2	RTI2_CAPEVT_0	SoC_TIMESYNC_XBAROUT_6					SoC Time Sync Crossbar (TIMESYNC_XBAR)	Level	RTI2 Counter Capture Input Event		
	RTI2_CAPEVT_1	SoC_TIMESYNC_XBAROUT_7									
RTI3	RTI3_CAPEVT_0	SoC_TIMESYNC_XBAROUT_8							SoC Time Sync Crossbar (TIMESYNC_XBAR)	Level	RTI3 Counter Capture Input Event
	RTI3_CAPEVT_1	SoC_TIMESYNC_XBAROUT_9									

Note

For more information on the interconnects, see the *System Interconnect* chapter.

For more information on the power, reset and clock management, see the corresponding sections within the *Device Configuration* chapter.

For more information on the device interrupt controllers, see the *Interrupt Controllers* chapter.

4.18 WWDT Integration

There are 4x WWDT modules integrated in the device. The diagram and tables below show the device integration details.

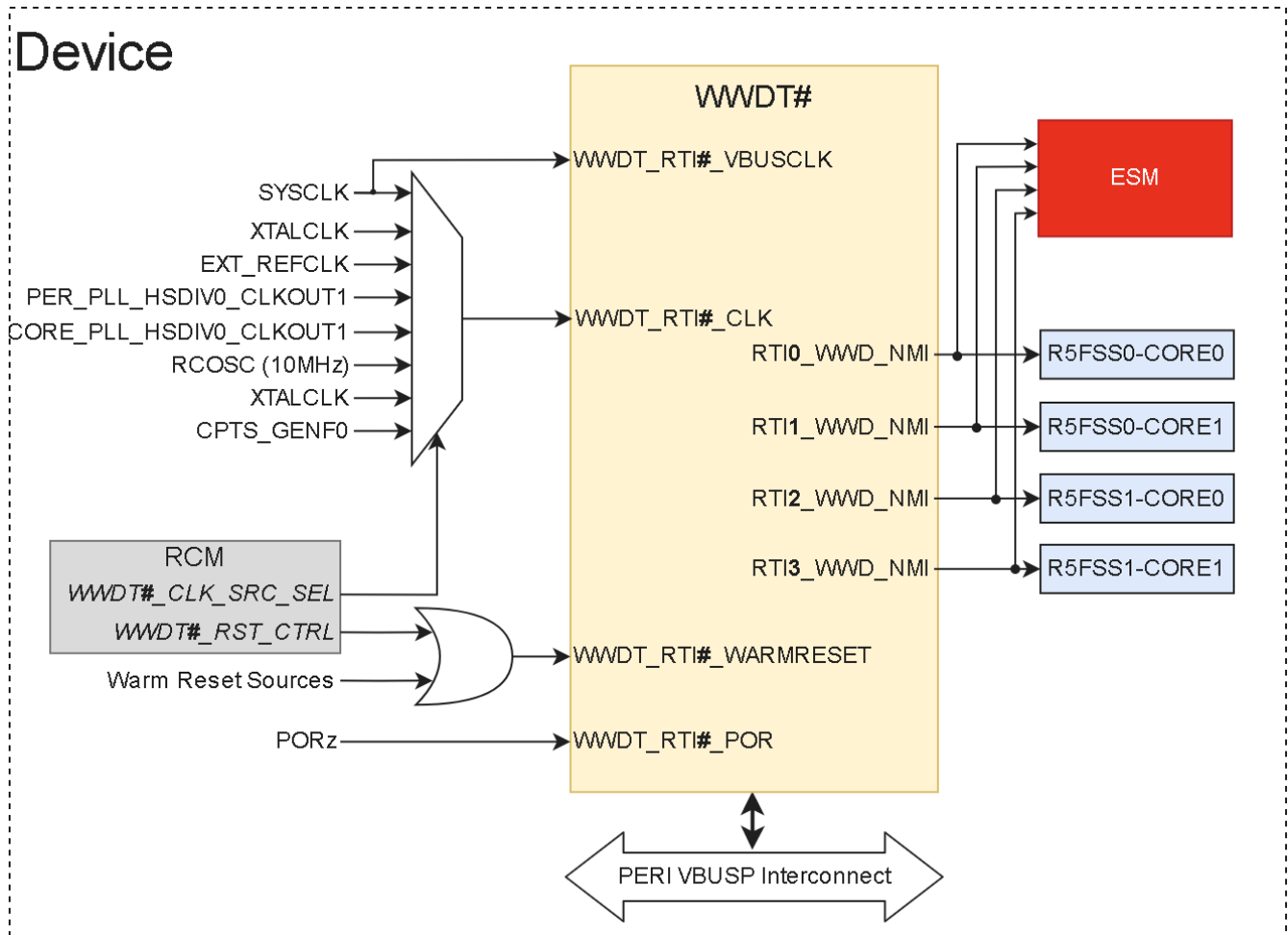

ADVANCE INFORMATION

Figure 4-22. WWDT Integration

The tables below summarize the integration of WWDT# (where # = 0, 1, 2, 3) in the device.

Each WWDT# instance is supplied by dedicated WWDTCLK# mux.

Table 4-61. WWDT Device Integration

This table describes the module device integration details.

Module Instance	Device Allocation	SoC Interconnect
WWDT0	✓	VBUSP CORE Interconnect
WWDT1	✓	VBUSP CORE Interconnect
WWDT2	✓	VBUSP CORE Interconnect
WWDT3	✓	VBUSP CORE Interconnect

Table 4-62. WWDT Clocks

This table describes the module clocking signals.

Module Instance	Module Clock Input	Source Clock Signal	Source	Default Freq	Description
WWDT0	WWDT0_ICLK (VBUSP_CLK)	SYS_CLK	PLL_CORE_CLK: HSDIV0_CLKOUT0	200 MHz	WWDT0 VBUSP Interface Clock
	WWDT0_FCLK (WWDT_CLK)	XTALCLK	External Crystal (XTAL)	25 MHz	WWDT0 Functional Clock
		EXT_REFCLK	External Reference Clock (EXT_REFCLK)	100 MHz	
		SYS_CLK	PLL_CORE_CLK: HSDIV0_CLKOUT0	200 MHz	
		DPLL_PER_HSDIV0_CLK OUT1	PLL_PER_CLK: HSDIV0_CLKOUT1	192 MHz	
		DPLL_CORE_HSDIV0_CLK OUT1	PLL_CORE_CLK: HSDIV0_CLKOUT1	500 MHz	
		RCCLK10M	Internal 10 MHz RC Oscillator (RCCLK10M)	10 MHz	
		XTALCLK	External Crystal (XTAL)	25 MHz	
		CTPS_GENF0	CPSW3G CPTS GENF0 Clock	50 MHz	
WWDT1	WWDT1_ICLK (VBUSP_CLK)	SYS_CLK	PLL_CORE_CLK: HSDIV0_CLKOUT0	200 MHz	WWDT1 VBUSP Interface Clock
	WWDT1_FCLK (WWDT_CLK)	XTALCLK	External Crystal (XTAL)	25 MHz	WWDT1 Functional Clock
		EXT_REFCLK	External Reference Clock (EXT_REFCLK)	100 MHz	
		SYS_CLK	PLL_CORE_CLK: HSDIV0_CLKOUT0	200 MHz	
		DPLL_PER_HSDIV0_CLK OUT1	PLL_PER_CLK: HSDIV0_CLKOUT1	192 MHz	
		DPLL_CORE_HSDIV0_CLK OUT1	PLL_CORE_CLK: HSDIV0_CLKOUT1	500 MHz	
		RCCLK10M	Internal 10 MHz RC Oscillator (RCCLK10M)	10 MHz	
		XTALCLK	External Crystal (XTAL)	25 MHz	
		CTPS_GENF0	CPSW3G CPTS GENF0 Clock	50 MHz	

Table 4-62. WWDT Clocks (continued)

This table describes the module clocking signals.

Module Instance	Module Clock Input	Source Clock Signal	Source	Default Freq	Description
WWDT2	WWDT2_ICLK (VBUSP_CLK)	SYS_CLK	PLL_CORE_CLK: HSDIV0_CLKOUT0	200 MHz	WWDT2 VBUSP Interface Clock
	WWDT2_FCLK (WWDT_CLK)	XTALCLK	External Crystal (XTAL)	25 MHz	WWDT2 Functional Clock
		EXT_REFCLK	External Reference Clock (EXT_REFCLK)	100 MHz	
		SYS_CLK	PLL_CORE_CLK: HSDIV0_CLKOUT0	200 MHz	
		DPLL_PER_HSDIV0_CLK OUT1	PLL_PER_CLK: HSDIV0_CLKOUT1	192 MHz	
		DPLL_CORE_HSDIV0_CLK KOUT1	PLL_CORE_CLK: HSDIV0_CLKOUT1	500 MHz	
		RCCLK10M	Internal 10 MHz RC Oscillator (RCCLK10M)	10 MHz	
		XTALCLK	External Crystal (XTAL)	25 MHz	
		CTPS_GENF0	CPSW3G CPTS GENF0 Clock	50 MHz	
WWDT3	WWDT3_ICLK (VBUSP_CLK)	SYS_CLK	PLL_CORE_CLK: HSDIV0_CLKOUT0	200 MHz	WWDT3 VBUSP Interface Clock
	WWDT3_FCLK (WWDT_CLK)	XTALCLK	External Crystal (XTAL)	25 MHz	WWDT3 Functional Clock
		EXT_REFCLK	External Reference Clock (EXT_REFCLK)	100 MHz	
		SYS_CLK	PLL_CORE_CLK: HSDIV0_CLKOUT0	200 MHz	
		DPLL_PER_HSDIV0_CLK OUT1	PLL_PER_CLK: HSDIV0_CLKOUT1	192 MHz	
		DPLL_CORE_HSDIV0_CLK KOUT1	PLL_CORE_CLK: HSDIV0_CLKOUT1	500 MHz	
		RCCLK10M	Internal 10 MHz RC Oscillator (RCCLK10M)	10 MHz	
		XTALCLK	External Crystal (XTAL)	25 MHz	
		CTPS_GENF0	CPSW3G CPTS GENF0 Clock	50 MHz	

Table 4-63. WWDT Resets

This table describes the module reset signals.

Module Instance	Module Reset Input	Source Reset Signal	Source	Description
WWDT0	WWDT0_RST	Warm Reset (MOD_G_RST)	RCM Reset Control Register + Warm Reset Sources	WWDT0 Asynchronous Reset
	WWDT0_POR_RST	POR Reset (MOD_POR_RST)	Device Power-On Reset	WWDT0 Power-On Reset

Table 4-63. WWDT Resets (continued)

This table describes the module reset signals.

Module Instance	Module Reset Input	Source Reset Signal	Source	Description
WWDT1	WWDT1_RST	Warm Reset (MOD_G_RST)	RCM Reset Control Register + Warm Reset Sources	WWDT1 Asynchronous Reset
	WWDT1_POR_RST	POR Reset (MOD_POR_RST)	Device Power-On Reset	WWDT1 Power-On Reset
WWDT2	WWDT2_RST	Warm Reset (MOD_G_RST)	RCM Reset Control Register + Warm Reset Sources	WWDT2 Asynchronous Reset
	WWDT2_POR_RST	POR Reset (MOD_POR_RST)	Device Power-On Reset	WWDT2 Power-On Reset
WWDT3	WWDT3_RST	Warm Reset (MOD_G_RST)	RCM Reset Control Register + Warm Reset Sources	WWDT3 Asynchronous Reset
	WWDT3_POR_RST	POR Reset (MOD_POR_RST)	Device Power-On Reset	WWDT3 Power-On Reset

Table 4-64. WWDT Interrupt Requests

This table describes the module interrupt requests.

Module Instance	Module Interrupt Signal	Destination Interrupt Input	Destination	Type	Description
WWDT0	WWDT0_NMI_REQ	ESM0_PLS_IN_0	ESM0	Pulse	WWDT0 Window Watchdog Violation Non-Maskable Interrupt (NMI) Event
		R5FSS0_0_VIM_128	R5FSS0_CORE0		
WWDT1	WWDT1_NMI_REQ	ESM0_PLS_IN_1	ESM0	Pulse	WWDT1 Non-Maskable Interrupt (NMI) Event
		R5FSS0_1_VIM_128	R5FSS0_CORE1		
WWDT2	WWDT2_NMI_REQ	ESM0_PLS_IN_2	ESM0	Pulse	WWDT2 Non-Maskable Interrupt (NMI) Event
		R5FSS1_0_VIM_128	R5FSS1_CORE0		
WWDT3	WWDT3_NMI_REQ	ESM0_PLS_IN_3	ESM0	Pulse	WWDT3 Non-Maskable Interrupt (NMI) Event
		R5FSS1_1_VIM_128	R5FSS1_CORE1		

Note

For more information on the interconnects, see the *System Interconnect* chapter.

For more information on the power, reset and clock management, see the corresponding sections within the *Device Configuration* chapter.

For more information on the device interrupt controllers, see the *Interrupt Controllers* chapter.

4.19 DCC Integration

There are 4x DCC modules integrated in the device. The diagram below provides a visual representation of the device integration details.

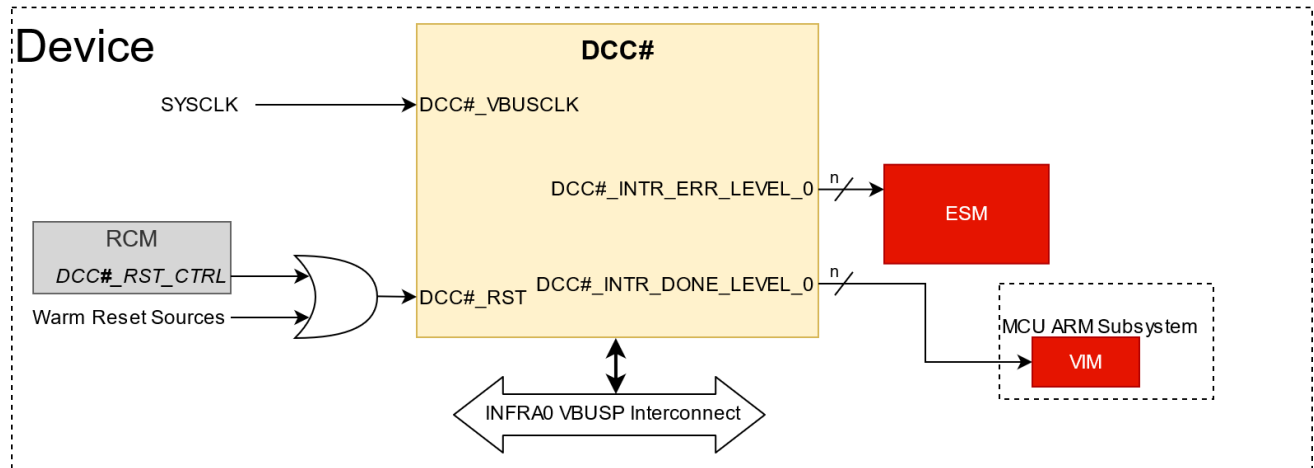

Figure 4-23. DCC Integration Diagram

The tables below summarize the device integration details of DCC.

Table 4-65. DCC Device Integration

This table describes the module device integration details.

Module Instance	Device Allocation	SoC Interconnect
MAIN_DCC0	✓	INFRA0 VBUSP Interconnect
MAIN_DCC1	✓	INFRA0 VBUSP Interconnect
MAIN_DCC2	✓	INFRA0 VBUSP Interconnect
MAIN_DCC3	✓	INFRA0 VBUSP Interconnect

Table 4-66. DCC Clocks

This table describes the module clocking signals.

Module Instance	Module Clock Input	Source Clock Signal	Source	Default Freq	Description
MAIN_DCC0	MAIN_DCC0_CLK (VBUSP_CLK)	SYS_CLK	PLL_CORE_CLK: HSDIV0_CLKOUT0	200 MHz	MAIN_DCC0 Interface Clock
MAIN_DCC1	MAIN_DCC1_CLK (VBUSP_CLK)	SYS_CLK	PLL_CORE_CLK: HSDIV0_CLKOUT0	200 MHz	MAIN_DCC1 Interface Clock
MAIN_DCC2	MAIN_DCC2_CLK (VBUSP_CLK)	SYS_CLK	PLL_CORE_CLK: HSDIV0_CLKOUT0	200 MHz	MAIN_DCC2 Interface Clock
MAIN_DCC3	MAIN_DCC3_CLK (VBUSP_CLK)	SYS_CLK	PLL_CORE_CLK: HSDIV0_CLKOUT0	200 MHz	MAIN_DCC3 Interface Clock

Table 4-67. DCC Resets

This table describes the module reset signals.

Module Instance	Module Reset Input	Source Reset Signal	Source	Description
MAIN_DCC0	MAIN_DCC0_RST	Warm Reset (SYNC_RST_N)	RCM + Warm Reset Sources	Synchronous Assertion Reset, Active Low
MAIN_DCC1	MAIN_DCC1_RST	Warm Reset (SYNC_RST_N)	RCM + Warm Reset Sources	Synchronous Assertion Reset, Active Low
MAIN_DCC2	MAIN_DCC2_RST	Warm Reset (SYNC_RST_N)	RCM + Warm Reset Sources	Synchronous Assertion Reset, Active Low
MAIN_DCC3	MAIN_DCC3_RST	Warm Reset (SYNC_RST_N)	RCM + Warm Reset Sources	Synchronous Assertion Reset, Active Low

Table 4-68. DCC Interrupt Requests

This table describes the module interrupt requests.

Module Instance	Module Interrupt Signal	Destination Interrupt Input	Destination	Type	Description
MAIN_DCC0	DCC0_done	DCC0_done	ALL R5FSS Cores	Level	DCC Done Interrupt
	DCC0_error	DCC0_error	ESM	Level	DCC Error Interrupt
MAIN_DCC1	DCC1_done	DCC1_done	ALL R5FSS Cores	Level	DCC Done Interrupt
	DCC1_error	DCC1_error	ESM	Level	DCC Error Interrupt
MAIN_DCC2	DCC2_done	DCC2_done	ALL R5FSS Cores	Level	DCC Done Interrupt
	DCC2_error	DCC2_error	ESM	Level	DCC Error Interrupt
MAIN_DCC3	DCC3_done	DCC3_done	ALL R5FSS Cores	Level	DCC Done Interrupt
	DCC3_error	DCC3_error	ESM	Level	DCC Error Interrupt

Note

For more information on the interconnects, see the *System Interconnect* chapter.

For more information on power, reset, and clock management, see the corresponding sections within the *Device Configuration* chapter.

For more information on the device interrupt controllers, see the *Interrupt Controllers* chapter.

[DCC0 - DCC1 Input Source Clock Mapping](#) and [DCC2 - DCC3 Input Source Clock Mapping](#) summarizes the DCC input source clocks in the device.

Table 4-69. DCC0 - DCC1 Input Source Clock Mapping

	Input:	MAIN_DCC0												MAIN_DCC1											
		Input0				Input1								Input0				Input1							
		MUX0				MUX1								MUX0				MUX1							
		/ value:	0	1	2	3	0	1	2	3	4	5	6	7	0	1	2	3	0	1	2	3	4	5	6
Clock Source		CL OC K0[0]	CL OC K0[1]	CL OC K0[2]	CL OC K0[3]	CL OC K1[0]	CL OC K1[1]	CL OC K1[2]	CL OC K1[3]	CL OC K1[4]	CL OC K1[5]	CL OC K1[6]	CL OC K1[7]	CL OC K0[0]	CL OC K0[1]	CL OC K0[2]	CL OC K0[3]	CL OC K1[0]	CL OC K1[1]	CL OC K1[2]	CL OC K1[3]	CL OC K1[4]	CL OC K1[5]	CL OC K1[6]	CL OC K1[7]
XTALCLK	Crystal Clock	✓							✓					✓											
RCCLK10M	Internal 10 MHz RC Oscillator. Always on			✓												✓						✓			
EXT_REFCLK	External Ref Clock		✓						✓					✓											
RCCLK32K	32 KHz RC Clock				✓					✓						✓									

Table 4-69. DCC0 - DCC1 Input Source Clock Mapping (continued)

		MAIN_DCC0														MAIN_DCC1													
		Input0				Input1										Input0				Input1									
		MUX0				MUX1										MUX0				MUX1									
		/ value:	0	1	2	3	0	1	2	3	4	5	6	7	0	1	2	3	0	1	2	3	4	5	6	7			
Clock Source	Input:	CL OC K0[0]	CL OC K0[1]	CL OC K0[2]	CL OC K0[3]	CL OC K1[0]	CL OC K1[1]	CL OC K1[2]	CL OC K1[3]	CL OC K1[4]	CL OC K1[5]	CL OC K1[6]	CL OC K1[7]	CL OC K0[0]	CL OC K0[1]	CL OC K0[2]	CL OC K0[3]	CL OC K1[0]	CL OC K1[1]	CL OC K1[2]	CL OC K1[3]	CL OC K1[4]	CL OC K1[5]	CL OC K1[6]	CL OC K1[7]				
PLL_CORE_CLKOUT (PLL_CORE)																													
DPLL_CORE_HSDIV0_CLKOUT0	Root clock for Processor SS and Interconnect (Not Mapped to DCC - covered by SYS_CLK below)																												
DPLL_CORE_HSDIV0_CLKOUT1	CPSW2G/ICSSG RGMII/GMII Clock																			✓									
PLL_PER_CLKOUT (PLL_PER)																													
DPLL_PER_HSDIV0_CLKOUT0	UART 5mbps Clocking																		✓										
DPLL_PER_HSDIV0_CLKOUT1	Peripheral Clocking																				✓								
Other IP Clocks																													
R5SS0_CLK	R5 Cluster 0 Clock						✓																						
R5SS1_CLK	R5 Cluster 1 Clock							✓																					
SYS_CLK	Interconnect System Clock					✓																							
WDT0_CLK	Watch Dog Timer																												
WDT1_CLK	Watch Dog Timer																												
WDT2_CLK	Watch Dog Timer																												
WDT3_CLK	Watch Dog Timer																												
MCAN0_CLK	MCAN Clock																												
MCAN1_CLK	MCAN Clock																												
TEMPSENSE_32K_CLK	32 KHz Clock (divided down from XTALCLK)																												
RMII1_REFCLK	IO Reference Clock Input																												
RMII2_REFCLK	IO Reference Clock Input																												
RGMII1_RXC	IO Receive clock input																												
RGMII2_RXC	IO Receive clock input																												
MII1_RXCLK	IO Receive clock input																												
MII2_RXCLK	IO Receive clock input																												
PR0_MII0_RXCLK	IO Receive clock input																												
PR0_MII1_RXCLK	IO Receive clock input																												
FSI0_RX_CLK	IO Receive clock input																						✓						
FSI1_RX_CLK	IO Receive clock input																							✓					
FSI2_RX_CLK	IO Receive clock input																								✓				
FSI3_RX_CLK	IO Receive clock input																								✓				

Table 4-70. DCC2 - DCC3 Input Source Clock Mapping

DCC_CLKSRC0 / DCC_CLKSRC1 value:		MAIN_DCC2											MAIN_DCC3											
		Input0			Input1								Input0			Input1								
		MUX0			MUX1								MUX0			MUX1								
		[0, 3-F]	1	2	0	1	2	3	4	5	6	7	[0, 3-F]	1	2	0	1	2	3	4	5	6	7	
Clock Source	Input:	CL OC K0[0]	CL OC K0[1]	CL OC K0[2]	CL OC K1[0]	CL OC K1[1]	CL OC K1[2]	CL OC K1[3]	CL OC K1[4]	CL OC K1[5]	CL OC K1[6]	CL OC K1[7]	CL OC K0[0]	CL OC K0[1]	CL OC K0[2]	CL OC K1[0]	CL OC K1[1]	CL OC K1[2]	CL OC K1[3]	CL OC K1[4]	CL OC K1[5]	CL OC K1[6]	CL OC K1[7]	
XTALCLK	Crystal Clock	✓											✓											
RCCLK10M	Internal 10 MHz RC Oscillator. Always on			✓											✓									
EXT_REFCLK	External Ref Clock		✓											✓										
RCCLK32K	32 KHz RC Clock																							
PLL_CORE_CLKOUT (PLL_CORE)																								
DPLL_CORE_HSDIV0_CLKOUT0	Root clock for Processor SS and Interconnect (Not Mapped to DCC - covered by SYS_CLK below)																							
DPLL_CORE_HSDIV0_CLKOUT1	CPSW2G/ICSSG RGMII/GMII Clock																							
PLL_PER_CLKOUT (PLL_PER)																								
DPLL_PER_HSDIV0_CLKOUT0	UART 5mbps Clocking																							
DPLL_PER_HSDIV0_CLKOUT1	Peripheral Clocking																							
Other IP Clocks																								
R5SS0_CLK	R5 Cluster 0 Clock																							
R5SS1_CLK	R5 Cluster 1 Clock																							
SYS_CLK	Interconnect System Clock				✓																			
WDT0_CLK	Watch Dog Timer					✓																		
WDT1_CLK	Watch Dog Timer						✓																	
WDT2_CLK	Watch Dog Timer							✓																
WDT3_CLK	Watch Dog Timer								✓															
MCAN0_CLK	MCAN Clock									✓														
MCAN1_CLK	MCAN Clock										✓													
TEMPSENSE_32K_CLK	32 KHz Clock (divided down from XTALCLK)											✓												
RMII1_REFCLK	IO Reference Clock Input														✓									
RMII2_REFCLK	IO Reference Clock Input															✓								
RGMII1_RXC	IO Receive clock input																✓							
RGMII2_RXC	IO Receive clock input																	✓						
MII1_RXCLK	IO Receive clock input																		✓					
MII2_RXCLK	IO Receive clock input																			✓				
PR0_MII0_RXCLK	IO Receive clock input																						✓	
PR0_MII1_RXCLK	IO Receive clock input																							✓
FSI0_RX_CLK	IO Receive clock input																							
FSI1_RX_CLK	IO Receive clock input																							
FSI2_RX_CLK	IO Receive clock input																							

ADVANCE INFORMATION

Table 4-70. DCC2 - DCC3 Input Source Clock Mapping (continued)

DCC_CLKSRC0 / DCC_CLKSRC1 value:		MAIN_DCC2											MAIN_DCC3										
		Input0			Input1								Input0			Input1							
		MUX0			MUX1								MUX0			MUX1							
		[0, 3-F]	1	2	0	1	2	3	4	5	6	7	[0, 3-F]	1	2	0	1	2	3	4	5	6	7
Clock Source	Input:	CL OC K0[0]	CL OC K0[1]	CL OC K0[2]	CL OC K1[0]	CL OC K1[1]	CL OC K1[2]	CL OC K1[3]	CL OC K1[4]	CL OC K1[5]	CL OC K1[6]	CL OC K1[7]	CL OC K0[0]	CL OC K0[1]	CL OC K0[2]	CL OC K1[0]	CL OC K1[1]	CL OC K1[2]	CL OC K1[3]	CL OC K1[4]	CL OC K1[5]	CL OC K1[6]	CL OC K1[7]
FSI3_RX_CLK	IO Receive clock input																						

4.20 ESM Integration

There is 1x ESM integrated in the device. The diagram below provides a visual representation of the device integration details.

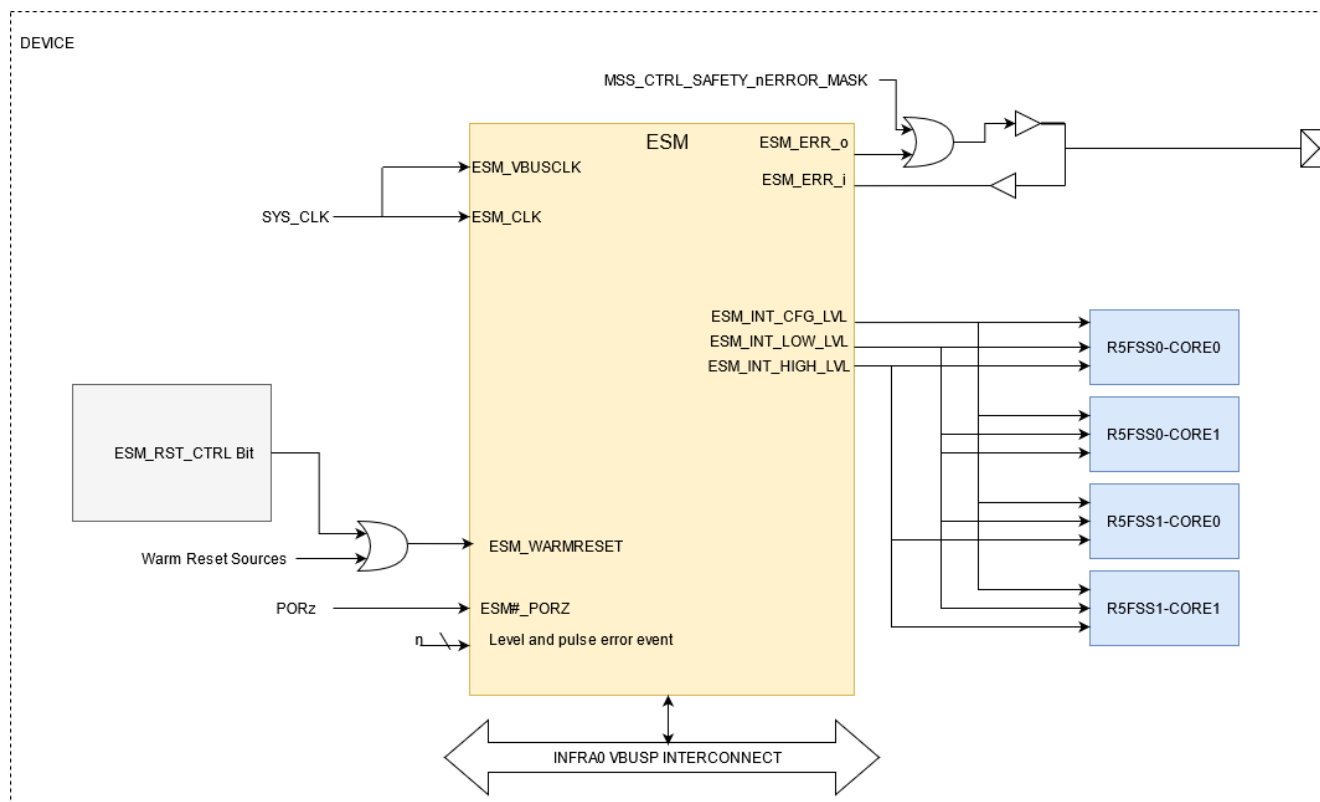

Figure 4-24. ESM Integration Diagram

The tables below summarize the device integration details of ESM.

Table 4-71. ESMDevice Integration

This table describes the ESM device integration details.

ESM Instance	Device Allocation	SoC Interconnect
ESM0	✓	INFRA0 VBUSP Interconnect

Table 4-72. ESMClocks

This table describes the ESM clocking signals.

ESM Instance	ESM Clock Input	Source Clock Signal	Source	Default Freq	Description
ESM0	ESM0_VBUSCLK	SYS_CLK	PLL_CORE_CLK: HSDIV0_CLKOUT0	200 MHz	ESM0 VBUSP Interface Clock
	ESM0_CLK				ESM0 Functional Clock

Table 4-73. ESM Resets

This table describes the ESM reset signals.

ESM Instance	ESM Reset Input	Source Reset Signal	Source	Description
ESM0	ESM0_RST	Warm Reset (MOD_G_RST)	RCM + Warm Reset Sources	ESM0 Asynchronous Reset
	ESM0_POR_RST	POR Reset (MOD_POR_RST)	Device Power-On Reset	ESM0 Power-On Reset

Table 4-74. ESM Interrupt Requests

This table describes the ESM interrupt requests.

ESM Instance	ESM Interrupt Signal	Destination Interrupt Input	Destination	Type	Description
ESM0	ESM0_INT_CFG_LVL_0	ESM0_INT_CFG_LVL	ALL R5FSS Cores	Level	ESM0 Configuration Error Interrupt
	ESM0_INT_LOW_LVL_0	ESM0_INT_LOW_LVL			ESM0 Low Priority Interrupt
	ESM0_INT_HIGH_LVL_0	ESM0_INT_HIGH_LVL			ESM0 High Priority Interrupt

Note

For more information on the interconnects, see the *System Interconnect* chapter.

For more information on power, reset, and clock management, see the corresponding sections within the *Device Configuration* chapter.

For more information on the device interrupt controllers, see the *Interrupt Controllers* chapter.

4.21 ECC Aggregator Integration

There is 1x ECC Aggregator integrated in the device. The diagram below provides a visual representation of the device integration details.

Figure 4-25. ECC Aggregator Integration

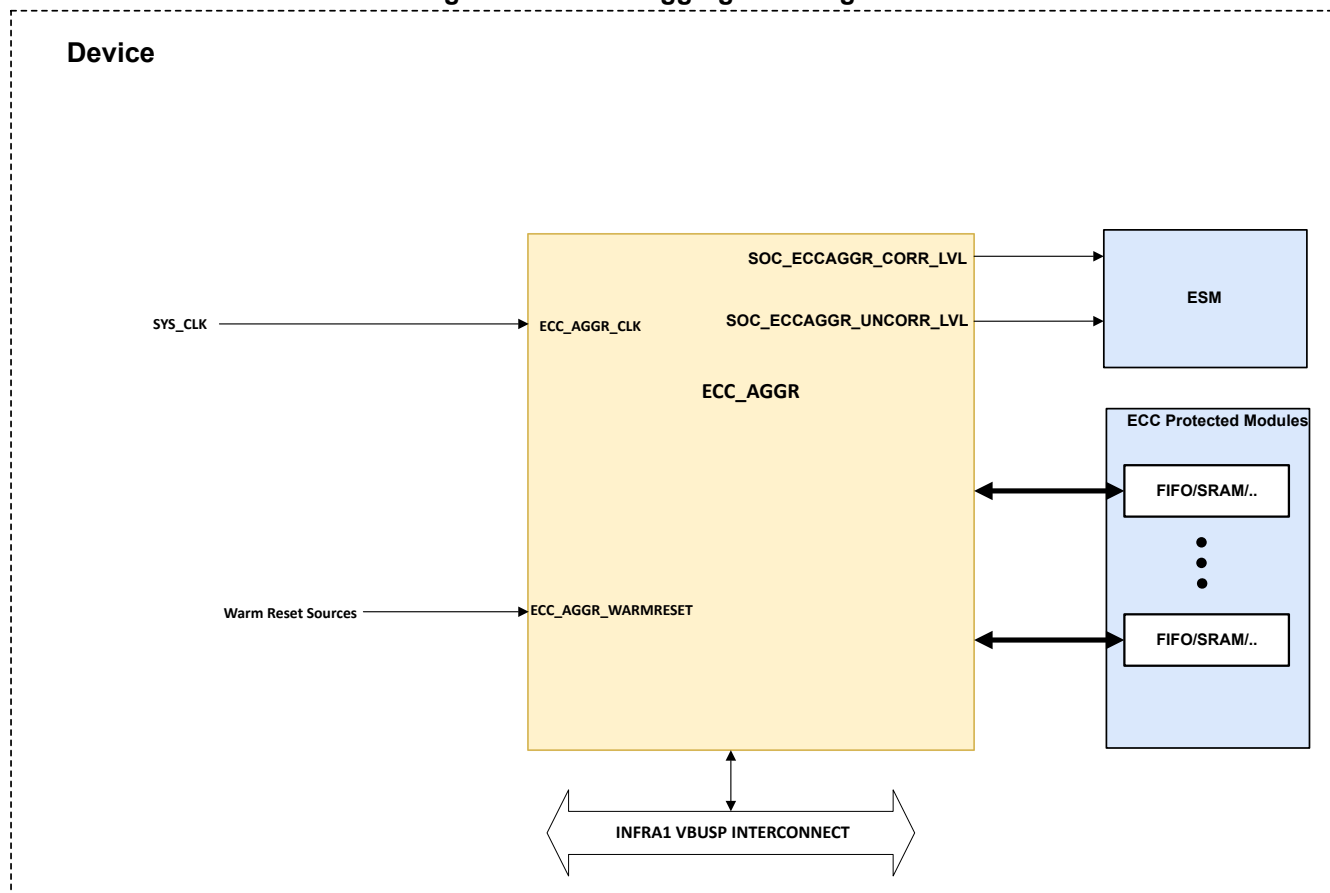

ADVANCE INFORMATION

The tables below summarize the device integration details of ECC Aggregator.

Table 4-75. ECC Aggregator Device Integration

This table describes the ECC Aggregator device integration details.

ECC Aggregator Instance	Device Allocation	SoC Interconnect
ECC Aggregator0	✓	INFRA1 VBUSP Interconnect

Table 4-76. ECC Aggregator Clocks

This table describes the ECC Aggregator clocking signals.

ECC Aggregator Instance	ECC Aggregator Clock Input	Source Clock Signal	Source	Default Freq	Description
ECC Aggregator0	ECC_AGGR_CLK	SYS_CLK	PLL_CORE_CLK: HSDIV0_CLKOUT0	200 MHz	ECC Aggregator Interface Clock

Table 4-77. ECC Aggregator Resets

This table describes the ECC Aggregator reset signals.

ECC Aggregator Instance	ECC Aggregator Reset Input	Source Reset Signal	Source	Description
ECC Aggregator 0	ECC_AGGR_WARMRESET(VBUSP_RSTn)	Warm Reset (MOD_G_RST)	RCM + Warm Reset Sources	ECC Aggregator0 Asynchronous Reset

Table 4-78. ECC Aggregator Event Requests

This table describes the ECC Aggregator interrupt requests.

ECC Aggregator or Instance	ECC Aggregator Interrupt Signal	Destination Interrupt Input	Destination	Type	Description
ECC Aggregator 0	SOC_ECCAGGR_UNCORR_LVL_0	SOC_ECCAGGR_UNCORR_LVL_0	ESM	Level	ECC Aggregator0 uncorrectable error event
	SOC_ECCAGGR_CORR_LVL_0	SOC_ECCAGGR_CORR_LVL_0			ECC Aggregator0 correctable error event

Table 4-79. Device modules with ECC Aggregator

This table describes the ECC Aggregator interrupt requests.

ECC Aggregator	ECC Aggregator Module instances
ECC Aggregator0	L2OCRAM_BANK0
	L2OCRAM_BANK1
	L2OCRAM_BANK2
	L2OCRAM_BANK3
	MBOX_SRAM
	TPTC00
	TPTC01

Note

For more information on the interconnects, see the *System Interconnect* chapter.

For more information on power, reset, and clock management, see the corresponding sections within the *Device Configuration* chapter.

For more information on the device interrupt controllers, see the *Interrupt Controllers* chapter.

4.22 MCRC Integration

There is 1x MCRC integrated in the device. The diagram below provides a visual representation of the device integration details.

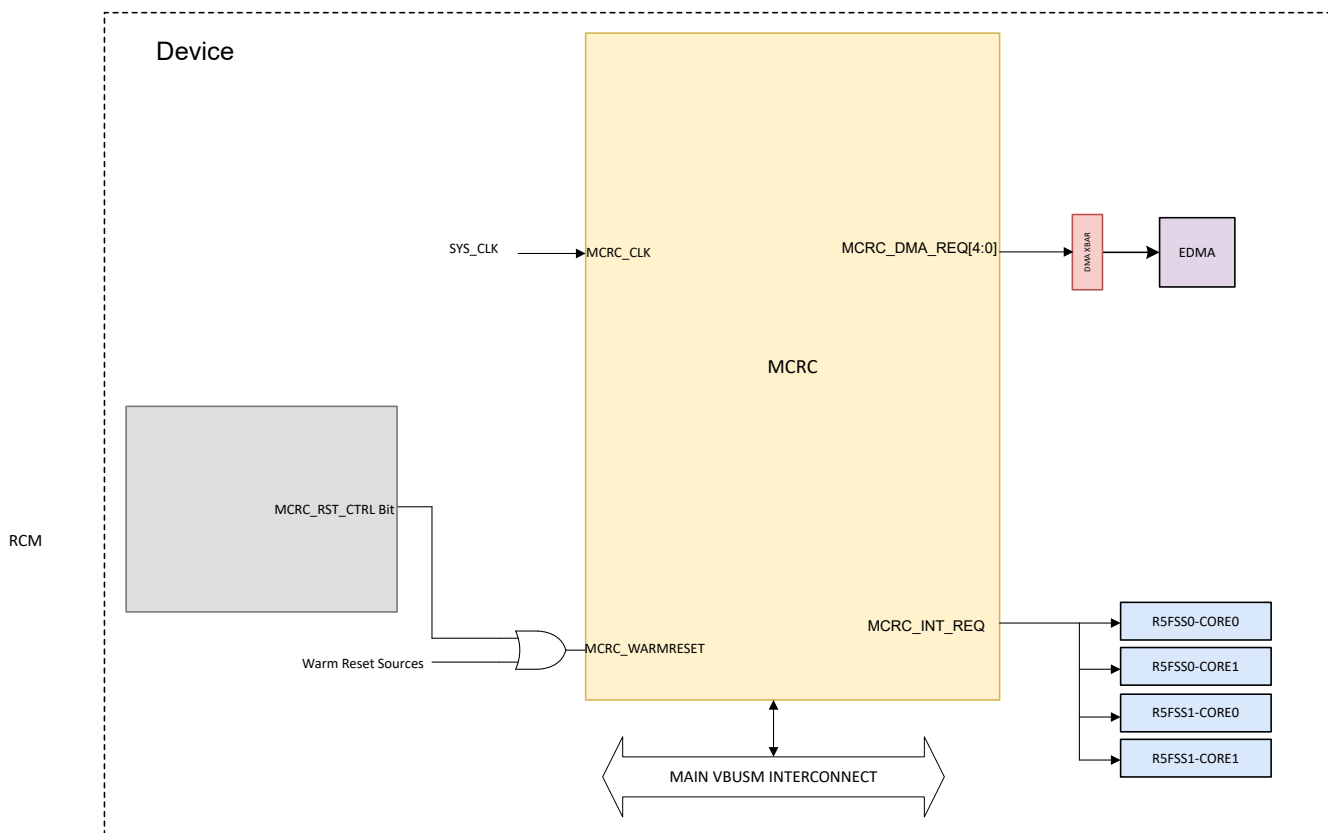

Figure 4-26. MCRC Integration

The tables below summarize the device integration details of MCRC# (where # = 1).

Table 4-80. MCRC Device Integration

This table describes the MCRC device integration details.

MCRC Instance	Device Allocation	SoC Interconnect
MCRC0	✓	CORE VBUSM Interconnect

Table 4-81. MCRC Clocks

This table describes the MCRC clocking signals.

MCRC Instance	MCRC Clock Input	Source Clock Signal	Source	Default Freq	Description
MCRC0	MCRC_CLK	SYS_CLK	PLL_CORE_CLK: HSDIV0_CLKOUT0	200 MHz	MCRC0 Interface Clock

Table 4-82. MCRC Resets

This table describes the MCRC reset signals.

MCRC Instance	MCRC Reset Input	Source Reset Signal	Source	Description
MCRC0	MCRC0_RST	Warm Reset (MOD_G_RST)	RCM + Warm Reset Sources	MCRC0 Asynchronous Reset

Table 4-83. MCRC Interrupt Requests

This table describes the MCRC interrupt requests.

MCRC Instance	MCRC Interrupt Signal	Destination Interrupt Input	Destination	Type	Description
MCRC0	MCRC0_INT_req	MCRC0_INT_req	ALL R5FSS Cores	Level	MCRC0 Event Interrupt

Table 4-84. MCRC DMA Requests

This table describes the MCRC DMA requests.

MCRC Instance	MCRC DMA Event	Destination DMA Event Input	Destination	Type	Description
MCRC0	MCRC0_DMA_0	MCRC0_dma_req[0]	EDMA Crossbar (DMA_XBAR)	Pulse	MCRC0 DMA Request
	MCRC0_DMA_1	MCRC0_dma_req[1]			
	MCRC0_DMA_2	MCRC0_dma_req[2]			
	MCRC0_DMA_3	MCRC0_dma_req[3]			

Note

For more information on the interconnects, see the *System Interconnect* chapter.

For more information on power, reset, and clock management, see the corresponding sections within the *Device Configuration* chapter.

For more information on the device interrupt controllers, see the *Interrupt Controllers* chapter.

This page intentionally left blank.



This chapter describes the steps for non-secure device initialization.

5.1 Initialization Overview	136
5.2 Boot Process	139
5.3 Boot Mode Pins	141
5.4 Boot Modes	142
5.5 PLL Configuration	148
5.6 Boot Image Format	149
5.7 Boot Memory Maps	154

5.1 Initialization Overview

Figure 5-1 is an overview of the initialization process and its steps:

- **Preinitialization:** Power, clock, and control connections must be present, and the boot configuration pins must be held at the desired logical levels.
- **Power, clock, reset ramp sequence:** Specific sequence that is applied by the power-management chip(s)
- **ROM code:** Responsible for finding, for downloading, and for executing the initial software (SBL)
- **Initial software:** Software that loads, prepares, and passes control to application software or to the high-level operating system (HLOS)
- **High-Level Operating System** or bare-metal application which runs on main processor(s)

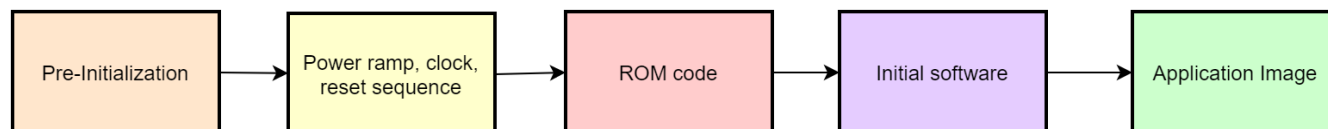

Figure 5-1. Initialization Process

The first two steps in the initialization process are hardware-oriented; however, they require an understanding of the process of configuring these system interface pins (balls on the device), which have software-configurable functionality. This configuration is an essential part of the chip configuration and is application-dependent. This chapter discusses these system-interface pins, the associated configuration registers, and memory structures that are vital to the correct initialization of the device.

5.1.1 ROM Code Overview

ROM bootloader (or ROM Code) is a software that resides in a on-chip read-only memory (ROM) to assist the customer in transferring and executing their application code. The device has two ROM codes operating in tandem – the Public ROM code, and the HSM ROM code.

In order to accommodate various system scenarios, the ROM Code supports several boot modes. These boot modes can be broadly classified as:

- Host boot modes
- Memory boot modes.

During a host boot, the device is configured to receive code from a host via the selected interface. Either the host writes the application code directly into internal memory or the ROM Code receives the application code on the selected interface and stores it in internal memory.

During a memory boot, the device transfers code from non-volatile memory to internal memory for execution.

In all boot modes, the entire boot operation can be partitioned into two sections:

1. Hardware initialization phase
2. Boot process.

During initialization, the ROM Code configures the device resources (PLLs, peripherals, pins) as needed to support the boot process. The resources used depend on the boot mode requirements.

During the boot process the boot image can be loaded into device memory and executed. HSM will perform code verification and allow, or forbid, the image execution.

Main configuration source for boot after power-up are the BOOTMODE pins sampled automatically after reset release and stored in device status registers. At ROM Code startup, these pin values are read from the registers to create the boot peripheral list and the boot configuration tables used later to initialize and startup the PLLs and boot peripherals.

5.1.2 Bootloader Modes

Table 5-1 shows the boot modes supported by ROM code.

Table 5-1. ROM Code Boot Modes

Boot Mode/Peripheral	Boot Media/Host	Notes
QSPI (4S) - Quad Read Mode	QSPI Flash	Download and boot SBL from QSPI flash in quad read mode. Attempt Primary SBL, followed by Secondary SBL if primary loading fails.
UART	External Host	Download and boot SBL from UART. Device is expected to get SBL from UART. Device supports the XMODEM protocol for download over UART.
QSPI (1S) - Single Read Mode	QSPI Flash	Download and boot SBL from QSPI flash in single read mode. Attempt Primary SBL, followed by Secondary SBL if primary loading fails.
QSPI (4S) - Quad Read UART Fallback Mode	QSPI Flash / External Host	Download and boot SBL from QSPI flash in quad read mode. Attempt Primary SBL, followed by Secondary SBL if primary loading fails. If Secondary SBL also fails then boot from external host via UART interface.
QSPI (1S) - Single Read UART Fallback Mode	QSPI Flash / External Host	Download and boot SBL from QSPI flash in single read mode. Attempt Primary SBL, followed by Secondary SBL if primary loading fails. If Secondary SBL also fails then boot from external host via UART interface.
DevBoot	N/A	No SBL. Used for development purposes only.

Note

Because different devices support different sets of peripherals, see the *device-specific* datasheet to obtain the list of peripherals supported in your device.

5.1.3 Terminology

- **Boot Mode Pins:** Boot mode pins provide vital information to ROM code for boot. These pins must be properly set up before power ramp.
- **Bootstrap:** Initial software launched by the ROM code during the memory booting phase.
- **Downloaded software:** Initial software downloaded into on-chip RAM by the ROM code during the peripheral booting phase.
- **eFuse:** A one-time programmable memory location usually set at the factory.
- **Flash loader:** Downloaded software launched by the ROM code during the preflashing stage. It also programs an image in external memories.
- **GP device:** General-purpose device (SoC) or a non-secure device.
- **Initial software:** Software executed by any of the ROM code mechanisms (memory booting or peripheral booting). Initial software is a generic term for bootstrap and downloaded software. This can be the SBL (secondary bootloader) responsible for loading an OS.
- **Memory booting:** ROM code mechanism that consists of downloading initial software from external memory to OCSRAM and executing.
- **Master CPU:** The Arm® Cortex® CPU for which CPU-ID is 0. It configures the multicore platform and starts the ROM code to ensure device booting from a mass storage memory (memory booting) or a peripheral interface (peripheral booting).
- **Peripheral booting:** ROM code mechanism that consists of polling selected interfaces, downloading, and executing initial software (in this case, downloaded software) in the internal RAM.
- **Preflashing:** A specific case of peripheral booting where the ROM code mechanism is used to program the external flash memory.
- **ROM Code:** or ROM bootloader (RBL), the on-chip software in device ROM that executes first and implements booting.
- **ROM Code-controlled Boot Phase:** This phase covers the sequence operations from the time the platform releases the reset to the time first user- or customer-owned software starts execution. This phase is fully controlled by the device ROM code.

- **Booting Parameter Table:** A logical structure stored in the on-chip RAM memory and contains information for the boot, such as the boot file name or an address to boot from.

5.2 Boot Process

5.2.1 Public ROM Code Architecture

The Public ROM code has the following components and is described in the [Public ROM Code Architecture](#) diagram:

- Main
- Buffer manager
- X.509
- Log and Trace
- System
- Protocol
- Driver

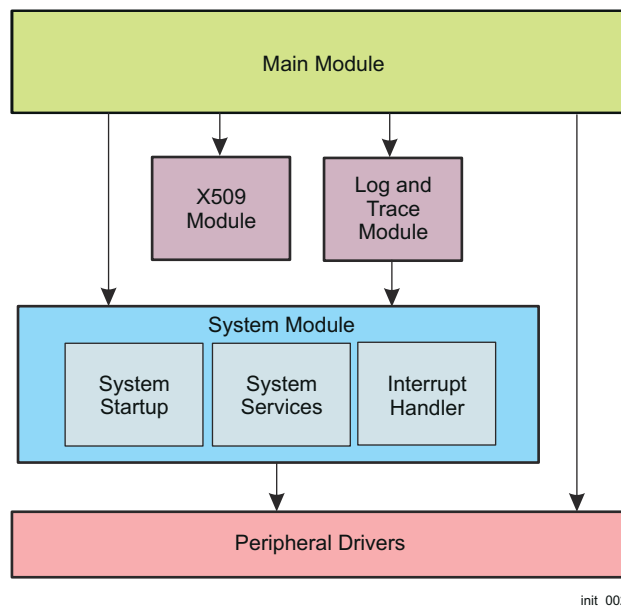

init_002

Figure 5-2. Public ROM Code Architecture

5.2.1.1 Main Module

The Main module contains the top level execution loop. This loop repeats until a boot image has been received or directed to sleep by the HSM. The main loop has two different execution sub-paths based on the boot peripheral.

- **Image Path** This path is used by the QSPI boot modes. In these cases the image data can be directly read by both, MCU and HSM, in place.
- **Block Path** This path is used by the UART in raw mode. In this mode data is received from the peripheral in blocks. Blocks are accumulated in the boot buffer until a full X.509 certificate header has been received, at which point this full certificate and any subsequent blocks are passed to the HSM as they arrive.

The main level is able to detect if a received boot image is in the correct format and reject non-conforming images.

5.2.1.2 X509 Module

The X509 module parses the boot header. The boot header is an X.509 certificate as defined in [RFC5280](#). Extensions specific to boot are described in [Section 5.6.2, X.509 Certificate](#).

This module also includes an OID decoder as well as defines OID values as C #define constants for any values that can be used during boot.

5.2.1.3 Buffer Manager Module

The buffer manager module is used to allocate buffers to hold boot data. The MCU code allocates a buffer when it is ready to read a block of data from the boot peripheral. Once the data is read the buffer ownership is passed to the HSM. When the HSM has completed processing the data in the buffer ownership is returned to the MCU, which then frees the buffer.

5.2.1.4 Log and Trace Module

The Log and Trace modules are not integral to the boot process. Instead, they provide ability to record operation of the ROM code and track unexpected occurrences.

Note

Log and trace function is currently TI internal.

User may send log and trace data to a TI representative for inspection in case other debug techniques fail.

5.2.1.5 System Module

The system module provides services to other modules. These services are not directly related to boot drivers. The system module is the only module that operates in the supervisor mode of the MCU. The system module supports the following functions:

- Interrupt enable, disable, and service
- IPC
- Power
- Pinmux
- Clock

The main level is able to detect if a received boot image is in the correct format and reject non-conforming images.

5.2.1.6 Protocol Module

The protocol modules provide implementation of high-level data transfer protocols. The XMODEM protocols reside in this layer. These modules provide services as defined in well-known standards.

5.2.1.7 Driver Module

The driver module implements the low level peripheral drivers.

5.2.2 HSM ROM Description

In a general-purpose (GP) device, HSM ROM performs the following functions:

- Device management
- Configures the boot vectors (in BOOT_CFG) and controls reset release of R5 core. That is, HSM is the boot master of R5 core.
- IPC configuration via mailbox RAM
- X509 certificate parsing
- DTBE configuration to SHA512 for image integrity checks
- HSM firmware loading

5.3 Boot Mode Pins

Boot Mode pins provide means to select the boot mode and options before the device is powered up. After every POR, they are the main source to populate the Boot Parameter Tables. See *Boot Parameter Tables* for table list and description.

Boot mode pins can be divided into the following categories:

- **BOOTMODE[3:0]** – Select the requested boot (primary) mode after POR, that is, the peripheral/memory to boot from.

Note

It is user's responsibility to set the boot mode pins (via pullups or pulldowns, and jumpers/switches) depending on the desired boot scenario.

5.3.1 BOOTMODE Pin Mapping

The ROM execution is directed through the main boot mode pins. This provides flexibility through additional booting peripherals. The device must be powered and functional.

Main boot mode pins are shown in [Table 5-2](#).

Any Bootmode pins marked as Reserved or not used must be tied high or low with pull resistors. They should not be left floating.

Table 5-2. BOOTMODE Pin Mapping

Boot Mode	SPI0_D0_pad (SOP3)	SPI0_CLK_pad (SOP2)	QSPI_D1 (SOP1)	QSPI_D0 (SOP0)
QSPI (4S) - Quad Read Mode	0	0	0	0
UART	0	0	0	1
QSPI (1S) - Single Read Mode	0	0	1	0
QSPI (4S) - Quad Read UART Fallback Mode	0	1	0	0
QSPI (1S) - Single Read UART Fallback Mode	0	1	0	1
DevBoot	1	0	1	1
Unsupported Boot Mode	All other combinations not defined above			

The ROM Code will configure any PLLs required during the boot process.

Note

Reference clock selections may be limited by the device. Please consult the device specific datasheet to determine which system clock frequencies are valid.

5.4 Boot Modes

5.4.1 QSPI Boot

The following apply to all or multiple boot modes that are QSPI related.

5.4.1.1 QSPI (4S)

Refer to [QSPI/SPI Boot](#) section for more information about all SPI boot modes.

[Table 5-3](#) summarizes the QSPI pin configuration done by ROM code for QSPI boot device on port 0.

Table 5-3. QSPI (4S) Boot Pinmux

Package Name	Function Name	Ball #	Input Override	Input Override Control	Output Override	Output Override Control	PinMux Mode #	PI	PU/PD Sel	SC1	GPIO Sel	Qual Sel	Input Invert Sel	HS Mode	HS Controller
QSPI0_CS0	QSPI0_CS0	0	0	0	0	0	0	1	0	1	0	0	0	0	0
QSPI0_CLK0	QSPI0_CLK	2	0	0	0	0	0	1	0	1	0	0	0	0	0
QSPI0_D0	QSPI0_D0	3	0	0	0	0	0	1	0	1	0	0	0	0	0
QSPI0_D1	QSPI0_D1	4	0	0	0	0	0	1	0	1	0	0	0	0	0
QSPI0_D2	QSPI0_D2	5	0	0	0	0	0	1	0	1	0	0	0	0	0
QSPI0_D3	QSPI0_D3	6	0	0	0	0	0	1	0	1	0	0	0	0	0
QSPI0_CLKLB	QSPI0_CLKLB	145	0	0	0	0	0	1	0	1	0	0	0	0	0

Note

All signals in the table will be configured even though some may not be used by this particular boot mode.

5.4.1.1.1 QSPI (4S) Bootloader Operation

Device supports 1S-1S-4S mode of QSPI configuration for fast read operation. This means that command and address are issued in single bit transfer mode and data access occurs in quad bit mode. The Command and Address issued are 8 bits and 24 bits followed by 8 dummy cycles. 40 MHz is the supported frequency of operation.

QSPI (4S) Module Configuration:

- QSPI has two associated memory regions, the first memory region is dedicated to the configuration port i.e all internal registers can be programmed and serial transfers made from the supported external QSPI flash devices. Configuration region is available at 0x4820_0000 in the SoC address map.
- The second memory region is associated mainly with the memory-mapped port and is used for communication directly with external flash devices, the memory region starts at 0x6000_0000. Code will be copied from this region to internal RAM and then execution starts.
- Serial data clock is derived from the clock source "DPLL_CORE_HSDIV0_CLKOUT2" (400MHz). This clock is divided by a factor 10 and results in a 40MHz interface clock.
- MODE3 of QSPI clock mode is used, Clock phase and polarity are set to 1, when data is not being transferred SCK=1, data shifted on falling edge and input on rising edge.

ROM Sequence:

- Command issued by ROM in this mode is 0x6B.
- RBL looks for SBL image at address 0x0000_0000, in case of boot failures due to corrupted image or any other reason, RBL tries to boot with redundant image placed at address 0x000F_0000.

Flash dependency:

- RBL does not perform any specific action to detect, reset, or power up the QSPI device. QSPI is assumed to be properly powered and reset completed before every attempt to boot by RBL.
- RBL also expects the QE bit is SET in non-volatile configuration so that flash is active in quad mode by default after POR.

5.4.1.1.1.1 QSPI (4S) Loading Process

QSPI (4S) boot mode is not eXecute-In-Place (XIP). ROM code first copies boot image into on-chip RAM and then executes it.

5.4.1.2 QSPI (1S)

Table 5-4 summarizes the QSPI pin configuration done by ROM code for QSPI (1S) boot device on port 0.

Table 5-4. QSPI (1S) Boot Pinmux

Package Name	Function Name	Ball #	Input Override	Input Override Control	Output Override	Output Override Control	PinMux Mode #	PI	PU/PD Sel	SC1	GPIO Sel	Qual Sel	Input Invert Sel	HS Mode	HS Controller
QSPI0_CSn0	QSPI0_CSn0	0	0	0	0	0	0	1	0	1	0	0	0	0	0
QSPI0_CLK0	QSPI0_CLK	2	0	0	0	0	0	1	0	1	0	0	0	0	0
QSPI0_D0	QSPI0_D0	3	0	0	0	0	0	1	0	1	0	0	0	0	0
QSPI_CLKLB	QSPI_CLKLB	145	0	0	0	0	0	1	0	1	0	0	0	0	0

Note

All signals in the table will be configured even though some may not be used by this particular boot mode.

5.4.1.2.1 QSPI (1S) Bootloader Operation

Device supports the 1S-1S-1S mode of QPSI configuration. This means that command, address, and data access are in single bit mode. The Command and Address issued are 8 bits and 24 bits followed by 8 dummy cycles. 40 MHz is the supported frequency of operation.

QSPI (1S) Module Configuration:

- QSPI has two associated memory regions, the first memory region is dedicated to the configuration port i.e all internal registers can be programmed and serial transfers made from the supported external QSPI flash devices. Configuration region is available at 0x4820_0000 in the SoC address map.
- The second memory region is associated mainly with the memory-mapped port and is used for communication directly with external flash devices, the memory region starts at 0x6000_0000. Code will be copied from this region to internal RAM and then execution starts.
- Serial data clock is derived from the clock source “DPLL_CORE_HSDIV0_CLKOUT2” (400MHz). This clock is divided by a factor 10 and results in a 40MHz interface clock.
- MODE3 of QSPI clock mode is used, Clock phase and polarity are set to 1, when data is not being transferred SCK=1, data shifted on falling edge and input on rising edge.

ROM Sequence:

- Command issued by ROM in this mode is 0x0B.
- RBL looks for SBL image at address 0x0000_0000, in case of boot failures due to corrupted image or any other reason, RBL tries to boot with redundant image placed at address 0x000F_0000.

Flash Dependency:

- RBL does not perform any specific action to detect, reset, or power up the QSPI device. QSPI is assumed to be properly powered and reset completed before every attempt to boot by RBL.

5.4.1.2.1.1 QSPI (1S) Loading Process

QSPI (1S) boot mode is not eXecute-In-Place (XIP). ROM code first copies boot image into on-chip RAM and then executes it.

5.4.2 UART Boot

ROM Code always configures the UART port to 115200 kbaud, 8-n-1 mode, and the XMODEM protocol is used to transfer the boot data.

Table 5-5 summarizes the UART pin configuration done by ROM code for UART host on port 0.

Table 5-5. UART Boot Pinmux

Function Name	Pad Num	Input Override	Input Override Control	Output Override	Output Override Control	Pinmux Sel	PI	PUPD Sel	SC1	Gpio Sel	Qual Sel	Inp Inv Sel	HS Mode	HS Master
UART0_TXD	28	0	0	0	0	0	1	0	1	0	0	0	0	0
UART0_RXD	27	0	0	0	0	0	1	0	1	0	0	0	0	0

5.4.2.1 UART Bootloader Operation

5.4.2.1.1 Initialization Process

In the UART boot mode, the selected UART module (port) is the only peripheral configured. The baud rate, data, parity, and stop bits are configured based on the information in the UART boot parameter table. The boot parameter table definitions and the boot configuration values that can be set are in *UART Boot Device Configuration* and *UART Boot Parameter Table*.

Once the ROM Code configures the UART, it sends the UART pings for few seconds, which can be seen in the host. The pings consist of an ASCII capital C character. The UART boot mode supports only the CRC mode of XMODEM and does not support CHECKSUM mode. Both 128 and 1024 byte block sizes are supported.

5.4.2.1.2 UART Loading Process

Before the ping from the device stops, load the boot image from the host using the XMODEM protocol.

5.4.2.1.2.1 UART XMODEM

The XMODEM protocol is used to transfer boot data. Only CRC mode is supported (not checksum), with both 128- and 1024-byte block sizes. The general, format of received frames is shown in Table 5-6 and Table 5-7.

Table 5-6. XMODEM 1024- and 128-byte Data Frames

STX	Block Num	Inv Block Num	1024 data bytes			CRC	CRC
SOH	Block Num	Inv Block Num	128 data bytes	CRC	CRC		

Table 5-7. XMODEM Data Frame Fields

Field	Value	Description
STX	0x02	The start character for 1024-byte CRC data blocks
SOH	0x01	The start character for 128-byte CRC data block
Block Num	0x01-0xFF – 0x00	The block number. The first block has value 1, and the block number wraps around 0xFF to 0
Inv Block Num	0xFE-0x00	The inverse block number (bit inverse of the block number)
CRC	Calculated	The 16-bit CRC generated from the polynomial 0x1021

The XMODEM protocol is implemented as a half-duplex protocol as shown in Table 5-8.

Table 5-8. Example of XMODEM Transfer protocol

Transmitter Sends	Receiver Sends
	← Ping ('C')
Frame 1	→
	← ACK (or NACK)

**Table 5-8. Example of XMODEM Transfer protocol
(continued)**

Transmitter Sends		Receiver Sends
Frame 2	→	
	←	ACK (or NACK)
EOT	→	
	←	ACK (or NACK)

5.4.2.1.3 UART Hand-Over Process

Once the complete image has been read and found in good integrity, the ROM Code will branch to the address defined in the Boot Info field of the boot header.

5.4.3 DevBoot/NoBoot

Table 5-9 shows configuration pins assignment to functions when boot mode is the No-boot mode.

Table 5-9. DevBoot/NoBoot Configuration Fields

Field	Value	Description
DevBoot/NoBoot	0	Development Boot
	1	No Boot (Unsupported)

These boot modes are useful for debugging purposes to preclude the execution of the ROM.

Note

NoBoot mode is **not supported** and will result in an undefined device state.

5.5 PLL Configuration

ROM code must be aware of the reference clock provided to PLLs. That is, the speed of the quartz crystal, or the clock supplied by an external clock oscillator.

Note

AM263x requires 25MHz XTAL clock source.

ROM code configures only PLLs which are required during boot. Therefore, if a PLL is required for the backup boot mode but not the primary boot mode, and the backup boot mode never executes, then the PLLs required for backup boot are not enabled.

The following tables show the HSDIV values that are programmed by the R5 ROM if a boot mode uses it. A value of NA means that the ROM does not program that HSDIV

Table 5-10. MAIN_PLL0 (CORE PLL) (800MHz)

PLL POSTDIV	HSDIV	Value	Frequency(MHz)	Boot Peripheral/IP
800 MHz	HSDIVx	10	80	QSPI/UART

Note

All other PLLs are not used or programmed by the ROM.

Note

The bringup and configuration of bootmode-specific PLLs by ROM code will result in a bootmode-specific device clocking setup. This will have an impact on which peripheral modules can readily be clocked and used by SBL/SPL prior to loading and executing HSM runtime.

5.6 Boot Image Format

5.6.1 Overall Structure

The boot image consists of an X.509 Certificate, which is optional for GP devices, followed immediately by a boot image blob.

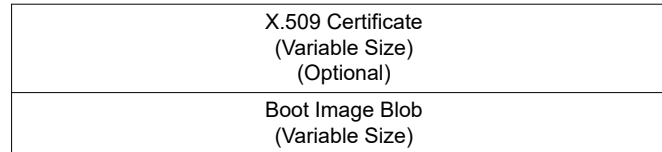

5.6.2 X.509 Certificate

The X.509 certificate is described in [RFC5280](#). Section 4.1 of the specification describes the format.

The X.509 fields relevant to the public boot (taken from RFC5280) are shown below.

```

Certificate ::= SEQUENCE {
    tbsCertificate      TBSCertificate,
    signatureAlgorithm  AlgorithmIdentifier,
    signatureValue      BIT STRING }
TBSCertificate ::= SEQUENCE {
    version             [0] EXPLICIT Version DEFAULT v1,
    serialNumber        CertificateSerialNumber,
    signature            AlgorithmIdentifier,
    issuer              Name,
    validity            Validity,
    subject             Name,
    subjectPublicKeyInfo SubjectPublicKeyInfo,
    issuerUniqueID     [1] IMPLICIT UniqueIdentifier OPTIONAL,
                      -- If present, version MUST be v2 or v3
    subjectUniqueID    [2] IMPLICIT UniqueIdentifier OPTIONAL,
                      -- If present, version MUST be v2 or v3
    extensions         [3] EXPLICIT Extensions OPTIONAL
                      -- If present, version MUST be v3
}
Extensions ::= SEQUENCE SIZE (1..MAX) OF Extension
Extension ::= SEQUENCE {
    extnID              OBJECT IDENTIFIER,
    critical            BOOLEAN DEFAULT FALSE,
    extnValue           OCTET STRING
                      -- contains the DER encoding of an ASN.1 value
                      -- corresponding to the extension type identified
                      -- by extnID
}
    
```

In general, an X.509 certificate contains a signature which is generated by signing a public key along with other certificate extensions. The public ROM code does not directly use the keys. In non-secure devices, the public key value is in general a don't care condition. The exception is certificates containing a degenerate RSA public key. GP devices with a degenerate RSA key allow for integrity checking of most (but not all) of the certificate.

The public ROM only needs to extract some of information from the X.509 formatted structure:

- The total size of the X.509 Certificate
- The total size of the boot image

The total size of the X.509 Certificate is determined by reading the length of the sequence containing the certificate. The length of the image is determined by parsing the certificate to find the extension field which holds the image length.

The ROM defines several extensions that are used only by TI for boot. These are placed in the extensions field of the TBS certificate.

5.6.3 Organizational Identifier (OID)

OID (organizational identifier) values are represented as a tree structure. TI has the following node registered:

1.3.6.1.4.1.294: *iso(1), identified-organization(3), dod(6), internet(1), private(4), enterprise(1), Texas Instruments(294)*

ROM code adds the following branch after *Texas Instruments: device-boot(1)*. The OID values shown in this section are leaves off the device boot branch.

5.6.4 Generating X.509 Certificates

X.509 Certificates are generated using OpenSSL and a configuration script to supply values in the extension fields.

5.6.4.1 Key Generation

The SBL must always be signed with a given OpenSSL key - Secure and GP devices. Secure must have encryption and authentication, GP device must only have authentication. The key used for authentication can be random or specific. If a random key is generated and SBL is signed with this, the ROM will copy the SBL image for authentication using memcopy. With this key, ROM code will be directed to use DMA to load the SBL for authentication which saves boot time.

5.6.4.1.1 RSA Key Generation

$$\text{Signature} = \text{digest} \cdot \text{privExp} \bmod n \cdot \text{privExp} \bmod n^{\text{privExp}} \quad (1)$$

Where n is the key size. Since the hash used is SHA-512 and the signature is an ASN.1 sequence containing the OID defining which has was used as well as the hash value, the degenerate RSA must have a value of n greater than the maximum digest size. Typically 4096-bit is chosen.

Note

AM263x Supports the following parameters:

- Public Key Length: RSA4K
- Decryption: AES-256 CBC
- Hashing: SHA512

The following sequence is used to generate degenerate RSA keys:

1. Create a random RSA key:

```
openssl genrsa -out key.pm 4096
```

2. Convert to text:

```
openssl rsa -in key.pem -text -noout > key.txt
```

3. Create an asn1 template for the degenerate key called degenerateKey.txt. Simply copy the values for modulus, prime (listed as p in key.txt), prime 2 (listed as q), and coefficient (listed as coeff). Set the public and private key exponents to 1, as well as the values for e_1 and e_2 . See the example below.

4. Convert the template to DER:

```
openssl asn1parse -genconf degenerateKey.txt -out degenerateKey.der
```

5. Sanity check the key:

```
openssl rsa -in degenerateKey.der -inform der -text -check
```

6. If there are no errors create the degenerate key pem file:

```
openssl rsa -in degenerateKey.der -inform der -outform pem -out degenerateKey.pem
```

An example degenerateKey.txt file is shown.

```
asn1=SEQUENCE:rsa_key
[rsa_key]
version=INTEGER:0
modulus=INTEGER<copied from key.txt>
pubExp=INTEGER:1
privExp=INTEGER:1
p=INTEGER:<copied from key.txt>
q=INTEGER:<copied from key.txt>
e1=INTEGER:1
```

```
e2=INTEGER:1
coeff=INTEGER<copied from key.txt>
```

Note that when copying the multi-byte fields from key.txt it is necessary to remove the colons, concatenate the lines and add a preceding 0x.

Degenerate RSA keys are valid RSA keys with the private exponent set to 1. This results in the signature field being equal to the digest.

5.6.4.2 Configuration Script

An example openssl configuration script is shown below. Not all extensions are required, but all possible are shown.

```
[ req ]
distinguished_name = req_distinguished_name
X509_extensions = v3_ca
prompt = no
dirstring_type = nobmp
[ req_distinguished_name ]
C = GB
ST = HI
L = Boston
O = Texas Instruments., Inc.
OU = DSP
CN = Bob
emailAddress = Bob@hou.ti.com
[ v3_ca ]
basicConstraints = CA:true
1.3.6.1.4.1.294.1.1 = ASN1:SEQUENCE:boot_seq
1.3.6.1.4.1.294.1.2 = ASN1:SEQUENCE:image_integrity
1.3.6.1.4.1.294.1.3 = ASN1:SEQUENCE:swrv
1.3.6.1.4.1.294.1.4 = ASN1:SEQUENCE:encryption
1.3.6.1.4.1.294.1.5 = ASN1:SEQUENCE:key_derivation
1.3.6.1.4.1.294.1.8 = ANSI:SEQUENCE:debug
[ boot_seq ]
certType =INTEGER:1
bootCore = INTEGER:16
bootArchWidth = INTEGER:32
destAddr = FORMAT:HEX,OCT:bc934b00
imageSize = INTEGER:0x00004860
[ image_integrity ]
shaType = OID:2.16.840.1.101.3.4.2.3
shaValue = FORMAT:HEX,OCT:4cf4d59ef77b5d9ab28d2ceb3c9fe83cb52ae6d2
[ swrv ]
rollback = INTEGER:0x00010001
[ encryption ]
Iv =FORMAT:HEX,OCT:00112233445566778899aabbccddeeff
Rstring = FORMAT:HEX,OCT:00112233445566778899aabbccddeeff101112131415161718191a1b1c1d1e1f
Icount = INTEGER:1
Salt = FORMAT:HEX,OCT:00112233445566778899aabbccddeeff
[ pllControl ]
[ debug ]
uid = FORMAT:HEX,OCT:00345678900
type = INTEGER:1
dbgE = INTEGER:0
secDbgEn = INTEGER:0
```

The certificate is then generated using the following openssl command:

```
openssl req -new -x509 -key <private_key_pem_file> -nodes -out <output_X.509_pem_file> -config
<config_file> -sha512
```

If a delegate key is being signed, then add the option -signkey <sign_key_pem_file> to the command above.

5.6.4.3 Image Data

The image data (blob) is considered simply as a byte stream. On devices that are multiple bytes wide (for example, PCIe) the image must be formatted so that all multi-byte fields match the endianness of the device. The MCU will always run in little endian mode.

5.7 Boot Memory Maps

5.7.1 Memory Layout/MPU

Table 5-11 shows an overview of the MPU configuration. In the R5FSS MPU, higher numbered regions have priority, therefore, where two regions overlap, the right-most region column defines the memory attributes in the table.

Table 5-11. Memory Layout/MPU

Memory Address	Regions	
0x0000_0000	Region 1 - Non-executable Full Access	Region 2 - ROM Read-only Exec
0x0001_FFFF		
.....		
0x0002_0000		Region 3 - TCM User Access
0x0002_3FFF		
.....		
0x0008_0000		Region 4 - ROM User Access
0x0008_3FFF		
.....		
0x4400_0000		Region 7 - TX Mailbox RAM
0x440F_FFFF		
.....		
0x4820_0000		Region 10 - QSPI Config Space
0x482F_FFFF		
.....		
0x6000_0000		Region 9 - QSPI Memory
0x61FF_FFFF		
.....		
0x7000_0000		Region 5 - All OCSRAM
0x700F_FFFF		
.....		
0x7200_0000	Region 8 - RX Mailbox RAM	
0x720F_FFFF		
.....		
0xFFFF_FFFF		

5.7.2 Global Memory Addresses Used by ROM Code

The ROM code uses several global memory addresses that are useful for debugging. They are shown in [Table 5-12](#).

Table 5-12. Global Memory Addresses

Group	Address	Size (bytes)	Content
Version	0x4605_0940	4	ROM code version (stored in ROM)
Warning/Error Logs	0x0008_2800	4096	Log Entry size: 8 words (128 bits) Word 1: Log_type - 0xABCD001 - Info 0xABCD002 - Warning 0xABCD003 - Error 0xABCD004 - Critical 2nd word: FileName - source file name 3rd word: Line number - line at which log reported in the source file 4th word: Value1 - Debug word1 5th word: Value2 - Debug word2 6th word: Timer count (lower) - lower 32-bit timer count 7th word: Timer count (upper) - upper 32-bit timer count
Free OCSRAM	0x70000000	2097152 2MB (Max)	Loadable space for SBL Note: The size of the memory space depends on the device variant.

The ROM code version information is a structure shown in [Table 5-13](#)

Table 5-13. ROM Code Version

Field	Address	Size (bytes)	Value
Version Number	0x4605_0940	4	"0x0001_0000" (1.0.0)
Device Name	0x4605_0944	12	"am263x"

This page intentionally left blank.

Chapter 6
Device Configuration



This chapter describes the device configuration details including information related to Control MMR's, Power, Reset, and Clocking.

6.1 Control Module (CTRLMMR)

6.1.1 Control Overview.....	159
-----------------------------	-----

6.1.1 Control Overview

The Control module is the main controller for top-level device behavior in various states. Module contains registers for configuration, bootstrap (SOP) signals, I/O pad multiplexing, clock selection, and many others. There are various CTRLMMR modules in this device:

General SoC Control Modules

- CTRLMMR0 (TOP_CTRL): Contains SoC-level configuration options
- CTRLMMR1 (MSS_CTRL): Contains Peripheral-level (non-CONTROLSS) configuration options
- CTRLMMR2 (CONTROLSS_GLOBAL_CTRL): Contains CONTROLSS-level configuration options (General control, reset, and clocking-related functions)

Pad Configuration Control Modules

- PADCFG_CTRLMMR0 (MSS_IOMUX): Controls the SoC-level terminal configuration options

Reset and Clocking Control Modules

- RCM_CTRLMMR0 (MSS_TOPRCM): Contains SoC-level Clock and Reset controls
- RCM_CTRLMMR1 (MSS_RCM): Contains Peripheral-level Clock and Reset controls

6.1.1.1 CTRLMMR0 (TOP_CTRL)

The CTRLMMR0 (TOP_CTRL) module consists of registers associated with the following functions:

- [Power OK Module](#)
- [Thermal Manager Module](#)
- [ADC Reference Buffer Control](#)

6.1.1.1.1 CTRLMMR0 Integration

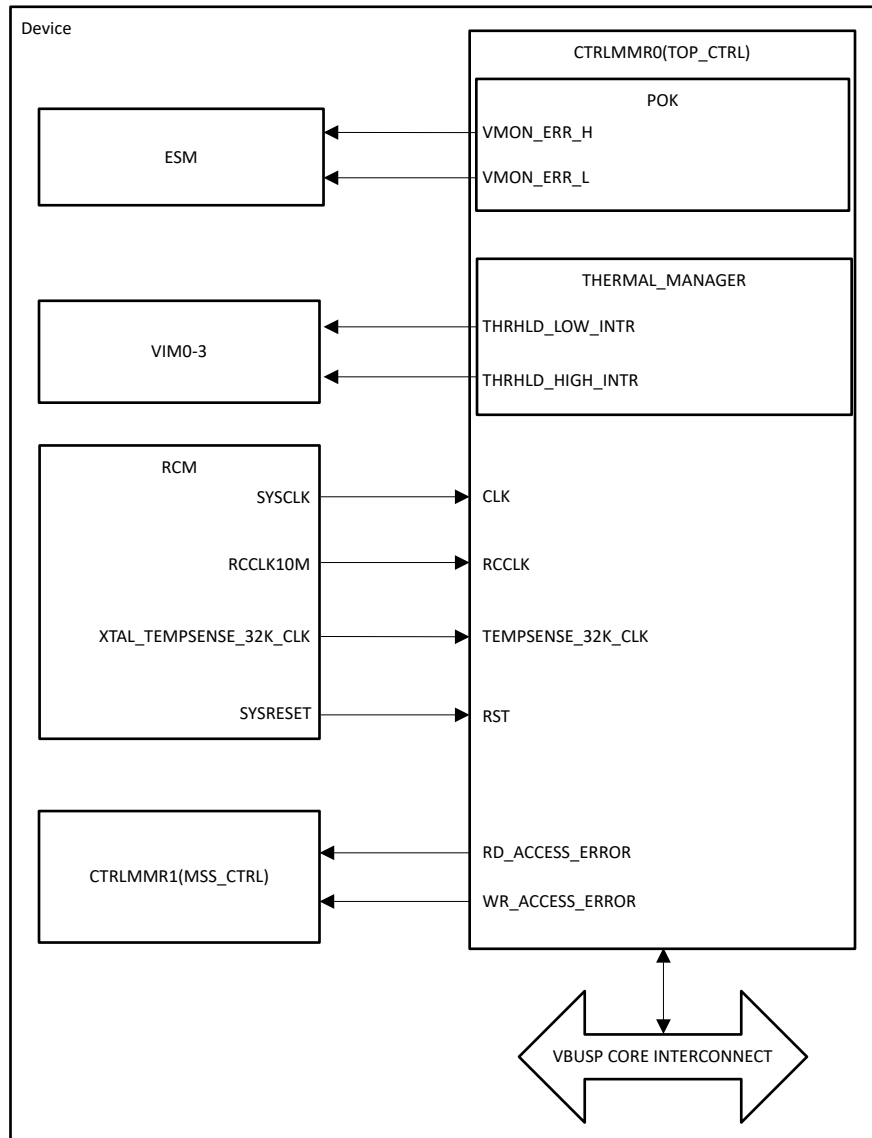

Figure 6-1. CTRLMMR0 Integration Diagram

Table 6-1. CTRLMMR0 Device Integration

Module Instance	Device Allocation	Interconnect
CTRLMMR0	✓	VBUSP CORE Interconnect

Table 6-2. CTRLMMR0 Clocks and Resets

Clocks				
Module Instance	Module Clock Input	Source Clock Signal	Source	Description
CTRLMMR0	CLK	SYSCLK	TOP_RCM	Functional and Interface Clock
CTRLMMR0	RCCLK	RCCLK10M	TOP_RCM	POK Filter clock
CTRLMMR0	TEMPSENSE_32K_CLK	XTAL_TEMPSENSE_32K_CLK	TOP_RCM	Thermal Manager clock

ADVANCE INFORMATION

Table 6-3. CTRLMMR0 Resets

Resets				
Module Instance	Module Clock Input	Source Clock Signal	Source	Description
CTRLMMR0	RST	SYSRESET	TOP_RCM	CTRLMMR0 Reset
CTRLMMR0	TSENSE_RESET	TSENSE_RESET	MSS_RCM	Thermal Manager Reset

Table 6-4. CTRLMMR0 Interrupt Requests

Module Instance	Module Interrupt Signal	Destination Interrupt Input	Destination	Type	Description
CTRLMMR0	RD_ACCESS_ERR	TOP_CTRL_RD_ACCE SS_ERR	MSS_CTRL	Level	Read Access Error Interrupt indicating protection, addressing, or lock violation
	WR_ACCESS_ERR	TOP_CTRL_WR_ACC ESS_ERR			Write Access Error Interrupt indicating protection, addressing, or lock violation
	THRHLDR_HIGH_INTR	INTR_TSENSE_H	VIM0-3		Temperature High Threshold Interrupt
	THRHLDR_LOW_INTERRUPT	INTR_TSENSE_L			Temperature Low threshold Interrupt

Table 6-5. CTRLMMR0 ESM Interrupts

Module Instance	Module Interrupt Signal	Destination Interrupt Input	Destination	Type	Description
CTRLMMR0	VMON_ERR_H	VMON_ERR_H	ESM	Level	VMON Error_H Interrupt
	VMON_ERR_L	VMON_ERR_L			VMON Error_L Interrupt

6.1.1.2 CTRLMMR1 (MSS_CTRL)

The CTRLMMR1 (MSS_CTRL) module has registers associated mainly with the following functions:

- [Section 6.1.1.2.2.1](#)
- [Section 6.1.1.2.2.2](#)
- [Section 6.1.1.2.2.3](#)
- [Section 6.1.1.2.2.5](#)
- [Section 6.1.1.2.2.7](#)
- [Section 6.1.1.2.2.8](#)
- [Section 6.1.1.2.2.9](#)
- [Section 6.1.1.2.2.10](#)
- [Section 6.1.1.2.2.11](#)
- [Section 6.1.1.2.2.12](#)
- [Section 6.1.1.2.2.13](#)

6.1.1.2.1 CTRLMMR1 Integration

ADVANCE INFORMATION

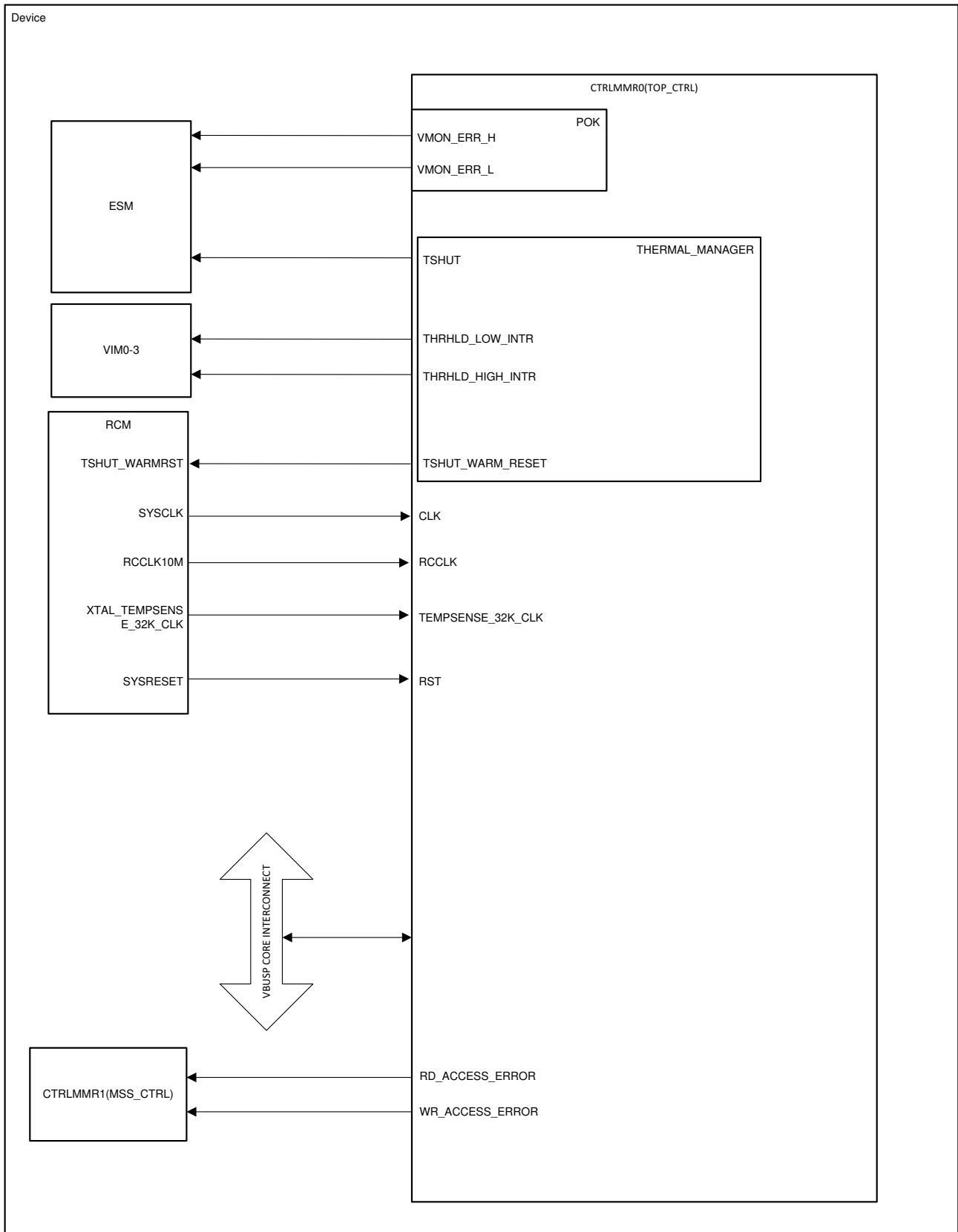

Figure 6-2. CTRLMMR1 Integration

Table 6-6. CTRLMMR1 Integration Attributes

Module Instance	Attributes
	Interconnect
CTRLMMR1	VBUSP CORE Interconnect

Table 6-7. CTRLMMR1 Clocks and Resets

Module Instance	Module Clock Input	Source Clock Signal	Source	Description
Clocks				
CTRLMMR1	CLK	SYSCLK	TOP_RCM	Functional and Interface Clock
Resets				
CTRLMMR01	RST	SYSRESET	TOP_RCM	CTRLMMR1 Reset

Table 6-8. CTRLMMR1 Hardware Requests

Interrupt Requests					
Module Instance	Module Interrupt Signal	Destination Interrupt Input	Destination	Description	Type
CTRLMMR1	ICSSM_PRU0_MBOX_READ_REQ	ICSSM_INTR_XBAR_IN5 1	ICSSM_INTR_XBAR	Interrupt indicating Mailbox Read Request to PRU0	Level
CTRLMMR1	ICSSM_PRU0_MBOX_READ_DONE	ICSSM_INTR_XBAR_IN5 3	ICSSM_INTR_XBAR	Interrupt indicating Mailbox Read Done to PRU0	Level
CTRLMMR1	ICSSM_PRU1_MBOX_READ_REQ	ICSSM_INTR_XBAR_IN5 2	ICSSM_INTR_XBAR	Interrupt indicating Mailbox Read Request to PRU0	Level
CTRLMMR1	ICSSM_PRU1_MBOX_READ_DONE	ICSSM_INTR_XBAR_IN5 4	ICSSM_INTR_XBAR	Interrupt indicating Mailbox Read Done to PRU0	Level
CTRLMMR1	R5SS0_CORE0_MBOX_READ_REQ	R5SS0_CORE0_INTR_IN _136	R5SS0_CORE0_VIM	Interrupt indicating Mailbox Read Request to R5SS0 CORE0	Level
CTRLMMR1	R5SS0_CORE0_MBOX_READ_DONE	R5SS0_CORE0_INTR_IN _137	R5SS0_CORE0_VIM	Interrupt indicating Mailbox Read Done to R5SS0 CORE0	Level
CTRLMMR1	R5SS0_CORE1_MBOX_READ_REQ	R5SS0_CORE1_INTR_IN _136	R5SS0_CORE1_VIM	Interrupt indicating Mailbox Read Request to R5SS0 CORE1	Level
CTRLMMR1	R5SS0_CORE1_MBOX_READ_DONE	R5SS0_CORE1_INTR_IN _137	R5SS0_CORE1_VIM	Interrupt indicating Mailbox Read Done to R5SS0 CORE1	Level

Table 6-8. CTRLMMR1 Hardware Requests (continued)

Interrupt Requests					
Module Instance	Module Interrupt Signal	Destination Interrupt Input	Destination	Description	Type
CTRLMMR1	R5SS1_CORE0_MBOX_READ_REQ	R5SS1_CORE0_INTR_IN_136	R5SS1_CORE0_VIM	Interrupt indicating Mailbox Read Request to R5SS1 CORE0	Level
CTRLMMR1	R5SS1_CORE0_MBOX_READ_DONE	R5SS1_CORE0_INTR_IN_137	R5SS1_CORE0_VIM	Interrupt indicating Mailbox Read Done to R5SS1 CORE0	Level
CTRLMMR1	R5SS1_CORE1_MBOX_READ_REQ	R5SS1_CORE1_INTR_IN_136	R5SS1_CORE1_VIM	Interrupt indicating Mailbox Read Request to R5SS1 CORE1	Level
CTRLMMR1	R5SS1_CORE1_MBOX_READ_DONE	R5SS1_CORE1_INTR_IN_137	R5SS1_CORE1_VIM	Interrupt indicating Mailbox Read Done to R5SS1 CORE1	Level
CTRLMMR1	R5SS0_CORE0_SW_IRQ	R5SS0_CORE0_INTR_IN_129	R5SS0_CORE0_VIM	Interrupt indicating SW Interrupt to R5SS0 CORE0	Level
CTRLMMR1	R5SS0_CORE1_SW_IRQ	R5SS0_CORE1_INTR_IN_129	R5SS0_CORE1_VIM	Interrupt indicating SW Interrupt to R5SS0 CORE1	Level
CTRLMMR1	R5SS1_CORE0_SW_IRQ	R5SS1_CORE0_INTR_IN_129	R5SS1_CORE1_VIM	Interrupt indicating SW Interrupt to R5SS1 CORE0	Level
CTRLMMR1	R5SS1_CORE1_SW_IRQ	R5SS1_CORE1_INTR_IN_129	R5SS1_CORE1_VIM	Interrupt indicating SW Interrupt to R5SS1 CORE1	Level
CTRLMMR1	R5SS0_CORE0_MPU_PROT_ERRAGG	R5SS0_CORE0_INTR_IN_70	R5SS0_CORE0_VIM	Aggregated Interrupt indicating MPU Protection Error to R5SS0 CORE0	Level

Table 6-8. CTRLMMR1 Hardware Requests (continued)

Interrupt Requests					
Module Instance	Module Interrupt Signal	Destination Interrupt Input	Destination	Description	Type
CTRLMMR1	R5SS0_CORE1_MPU_PROT_ERRAGG	R5SS0_CORE1_INTR_IN_70	R5SS0_CORE1_VIM	Aggregated Interrupt indicating MPU Protection Error to R5SS0 CORE1	Level
CTRLMMR1	R5SS1_CORE0_MPU_PROT_ERRAGG	R5SS1_CORE0_INTR_IN_70	R5SS1_CORE0_VIM	Aggregated Interrupt indicating MPU Protection Error to R5SS1 CORE0	Level
CTRLMMR1	R5SS1_CORE1_MPU_PROT_ERRAGG	R5SS1_CORE1_INTR_IN_70	R5SS1_CORE1_VIM	Aggregated Interrupt indicating MPU Protection Error to R5SS1 CORE1	Level
CTRLMMR1	R5SS0_CORE0_MPU_ADDR_ERRAGG	R5SS0_CORE0_INTR_IN_69	R5SS0_CORE0_VIM	Aggregated Interrupt indicating MPU Address Error to R5SS0 CORE0	Level
CTRLMMR1	R5SS0_CORE1_MPU_ADDR_ERRAGG	R5SS0_CORE1_INTR_IN_69	R5SS0_CORE1_VIM	Aggregated Interrupt indicating MPU Address Error to R5SS0 CORE1	Level
CTRLMMR1	R5SS1_CORE0_MPU_ADDR_ERRAGG	R5SS1_CORE0_INTR_IN_69	R5SS1_CORE0_VIM	Aggregated Interrupt indicating MPU Address Error to R5SS1 CORE0	Level
CTRLMMR1	R5SS1_CORE1_MPU_ADDR_ERRAGG	R5SS1_CORE1_INTR_IN_69	R5SS1_CORE1_VIM	Aggregated Interrupt indicating MPU Address Error to R5SS1 CORE1	Level

Table 6-8. CTRLMMR1 Hardware Requests (continued)

Interrupt Requests					
Module Instance	Module Interrupt Signal	Destination Interrupt Input	Destination	Description	Type
CTRLMMR1	MMR_ACCESS_ERRAGGR	R5SS0_CORE0_INTR_IN_124	R5SS0_CORE0_VIM	Aggregated Interrupt indicating MMR Access Error	Level
		R5SS0_CORE1_INTR_IN_124	R5SS0_CORE1_VIM		
		R5SS0_CORE0_INTR_IN_124	R5SS0_CORE0_VIM		
		R5SS1_CORE1_INTR_IN_124	R5SS1_CORE1_VIM		
CTRLMMR1	TPCC0_INTAGGR	R5SS0_CORE0_INTR_IN_72	R5SS0_CORE0_VIM	Aggregated Interrupt from EDMA Interrupt sources	Level
		R5SS0_CORE1_INTR_IN_72	R5SS0_CORE1_VIM		
		R5SS0_CORE0_INTR_IN_72	R5SS0_CORE0_VIM		
		R5SS1_CORE1_INTR_IN_72	R5SS1_CORE1_VIM		
CTRLMMR1	TPCC0_ERRGGR	R5SS0_CORE0_INTR_IN_73	R5SS0_CORE0_VIM	Aggregated Interrupt from EDMA Error sources	Level
		R5SS0_CORE1_INTR_IN_73	R5SS0_CORE1_VIM		
		R5SS0_CORE0_INTR_IN_73	R5SS0_CORE0_VIM		
		R5SS1_CORE1_INTR_IN_73	R5SS1_CORE1_VIM		
ESM Events					
CTRLMMR1	TPCC0_ERRGGR	ESM_LVL_EVENT_63	ESM	Aggregated Error from EDMA Error sources	Level
CTRLMMR1	R5SS0_CORE0_CORR_ERRAGG	ESM_LVL_EVENT_47	ESM	Aggregated Correctable Memory ECC Error from R5SS0 CORE0	Level
CTRLMMR1	R5SS0_CORE1_CORR_ERRAGG	ESM_LVL_EVENT_49	ESM	Aggregated Correctable Memory ECC Error from R5SS0 CORE1	Level
CTRLMMR1	R5SS1_CORE0_CORR_ERRAGG	ESM_LVL_EVENT_55	ESM	Aggregated Correctable Memory ECC Error from R5SS1 CORE0	Level
CTRLMMR1	R5SS1_CORE1_CORR_ERRAGG	ESM_LVL_EVENT_57	ESM	Aggregated Correctable Memory ECC Error from R5SS1 CORE1	Level

Table 6-8. CTRLMMR1 Hardware Requests (continued)

Interrupt Requests					
Module Instance	Module Interrupt Signal	Destination Interrupt Input	Destination	Description	Type
CTRLMMR1	R5SS0_CORE0_UNCORR_ERRAGG	ESM_LVL_EVENT_48	ESM	Aggregated Uncorrectable Memory ECC Error from R5SS0 CORE0	Level
CTRLMMR1	R5SS0_CORE1_UNCORR_ERRAGG	ESM_LVL_EVENT_50	ESM	Aggregated Uncorrectable Memory ECC Error from R5SS0 CORE1	Level
CTRLMMR1	R5SS1_CORE0_UNCORR_ERRAGG	ESM_LVL_EVENT_56	ESM	Aggregated Uncorrectable Memory ECC Error from R5SS1 CORE0	Level
CTRLMMR1	R5SS1_CORE1_UNCORR_ERRAGG	ESM_LVL_EVENT_58	ESM	Aggregated Uncorrectable Memory ECC Error from R5SS1 CORE1	Level
CTRLMMR1	R5SS0_CORE0_TCM_ADDRPARITY_ERRAGG	ESM_LVL_EVENT_14	ESM	Aggregated TCM Address parity Error from R5SS0 CORE0	Level
CTRLMMR1	R5SS0_CORE1_TCM_ADDRPARITY_ERRAGG	ESM_LVL_EVENT_15	ESM	Aggregated TCM Address parity Error from R5SS0 CORE1	Level
CTRLMMR1	R5SS1_CORE0_TCM_ADDRPARITY_ERRAGG	ESM_LVL_EVENT_16	ESM	Aggregated TCM Address parity Error from R5SS1 CORE0	Level
CTRLMMR1	R5SS1_CORE1_TCM_ADDRPARITY_ERRAGG	ESM_LVL_EVENT_17	ESM	Aggregated TCM Address parity Error from R5SS1 CORE1	Level
CTRLMMR1	VBUSM_ERRAGG_H	ESM_LVL_EVENT_33	ESM	Aggregated VBUSM Bus Safety Error High	Level
CTRLMMR1	VBUSM_ERRAGG_L	ESM_LVL_EVENT_34	ESM	Aggregated VBUSM Bus Safety Error Low	Level
CTRLMMR1	VBUSP_ERRAGG_LH	ESM_LVL_EVENT_31	ESM	Aggregated VBUSP Bus Safety Error	Level

6.1.1.2.2 CTRLMMR1 Functional Description

6.1.1.2.2.1 R5SS CPU Global Configuration and Control

6.1.1.2.2.1.1 R5SS Lock Step/Dual Core Configuration

The R5SS0_CONTROL register configures the lockstep/dual core behavior of R5SS0.

When R5SS0_CONTROL.LOCK_STEP is programmed to 0x7, it configures R5SS0 to be in lockstep. When programmed to 0x0, it configures R5SS0 to be in dual core mode.

A reset must be issued to R5SS0 to switch between dual core and lockstep mode.

When R5SS0_CONTROL.RESET_FSM_TRIGGER is programmed to 0x7, it issues a reset to R5SS0.

The R5SS1_CONTROL register is used to configure the lockstep/Dual core behavior of R5SS1.

Note

By default, after a device reset, both R5SS0 and R5SS1 are in lockstep. Each cluster can be independently configured to be in dual core by the application.

Note

Lockstep to dual core switch can be programmed only once, and cannot be reprogrammed until the device's next power on reset cycle.

R5SS*_STATUS_REG. LOCK_STEP bitfield indicates the mode of R5SS. LOCK_STEP = 0 indicates the corresponding R5SS is in dual core mode, and LOCK_STEP = 1 indicates the corresponding R5SS is in lockstep mode.

6.1.1.2.2.1.2 R5 Core Halting and Unhalting

The R5SS*_CORE*_HALT register halts and unhalts the respective R5 Cores. Programming R5SS*_CORE*_HALT.HALT bitfield to 0x7 halts the respective R5 Core. Programming the bitfield to 0x0 unhalts the respective R5 Core.

6.1.1.2.2.1.3 R5 WFI

The R5SS*_CORE*_STAT register provides the WFE and WFI status of the respective R5 Cores.

R5SS*_CORE*_STAT.WFI_STAT = 1 indicates the respective R5 core is in WFI.

R5SS*_CORE*_STAT.WFE_STAT = 1 indicates the respective R5 core is in WFE.

6.1.1.2.2.2 Memory Initialization

The SRAM memories in the device are protected by SECDED ECC for functional safety. At bootup, the memory content must be initialized for ECC. Memory initialization can be triggered by the memory initialization registers.

6.1.1.2.2.2.1 R5 TCM Memory Initialization

R5SS*_ATCM_MEM_INIT. MEM_INIT bitfield, when programmed to 1, initializes the ATCM memories of the corresponding R5SS.

R5SS*_ATCM_MEM_INIT_STATUS. MEM_STATUS shows the status of memory initialization. If the bitfield reads '1', it indicates the memory initialization is in progress.

R5SS*_ATCM_MEM_INIT_DONE. MEM_INIT_DONE bitfield is set when the memory initialization is complete. Writing '1' to this field clears the field.

R5SS*_BTCM_MEM_INIT, R5SS*_BTCM_MEM_INIT_STATUS and R5SS*_BTCM_MEM_INIT_DONE are associated with R5SS BTCM memory initialization.

6.1.1.2.2.2.2 L2 OGRAM and Mailbox RAM and EDMA RAM Memory Initialization

The L2IOGRAM_MEM_INIT register triggers ECC initialization of L2OCMGRAM.

L2OCMGRAM is split into four banks.

L2IOCRAM_MEM_INIT.PARTITION0, when programmed to 1, triggers the initialization of Bank0 of L2 OCMCRAM.

Similarly PARTITION1, 2, and 3 bit fields trigger initialization of Bank1, 2, 3 of L2 OCMCRAM, respectively.

The L2IOCRAM_MEM_INIT_STATUS register shows the status of memory initialization. If the bitfield reads '1', it indicates the memory initialization is in progress.

L2IOCRAM_MEM_INIT_DONE.PARTITIONx bitfield is set when the memory initialization of corresponding bank of L2IOCRAM is complete. Writing '1' to this field clears the field.

The MAILBOXRAM_MEM_INIT, MAILBOXRAM_MEM_INIT_STATUS and MAILBOXRAM_MEM_INIT_DONE registers are associated with Mailbox RAM ECC Initialization

The TPCC_MEM_INIT, TPCC_MEMINIT_STATUS, and TPCC_MEM_INIT_DONE registers are associated with EDMA memory initialization.

6.1.1.2.2.3 EDMA Global Configuration and Event Aggregation

The register TPTC_DBS_CONFIG configures the burst size of the DMA transfer. The bitfields TPTC_A0 and TPT_A1 configure the burst size of TPTC00 and TPTC01, respectively.

The registers TPCC0_INTAGG_MASK, TPCC0_INTAGG_STATUS, and TPCC0_INTAGG_STATUS_RAW are associated with the aggregated interrupt from EDMA TPCC0_INTAGGR. The TPCC0_INTAGG_MASK register can be configured to mask unwanted interrupt sources from EDMA from triggering the TPCC0_INTAGGR interrupt.

The TPCC0_INTAGG_STATUS register indicates the status of interrupt sources which caused the TPCC0_INTAGGR interrupt to occur. The TPCC0_INTAGG_STATUS_RAW register indicates the raw status of interrupt sources of the TPCC0_INTAGGR interrupt.

6.1.1.2.2.4 EDMA Error Aggregation

6.1.1.2.2.5 CPSW Global Configuration

The CPSW_CONTROL register is used for global configuration of CPSW IP modes.

The CPSW_CONTROL.PORT*_MODE_SEL bitfield configures the Ethernet mode of the corresponding port of CPSW to be in either MII, RMII, or RGMII.

CPSW_CONTROL.RGMII*_ID_MODE, when set to 1, enables the internal delay mode for the transmit path of the corresponding RGMII port. This provides a phase shift of quarter cycle b/w clock and data.

CPSW_CONTROL.RMII*_REF_CLK_OE_N controls how the RMII REF_CLK is generated in the system, as shown in [Figure 6-3](#).

As shown in [Figure 6-3](#), the RMII*_REF_CLK can be generated from the device and fed to the CPSW IP and transmitted out to device pins. Alternately, the RMII*_REF_CLK can be sourced from external sources as an input to the device.

CPSW_CONTROL.RMII*_REF_CLK_SEL can be used to fine tune the timing of RMII_REF_CLK with respect to the data when the RMII*_REF_CLK is generated internally.

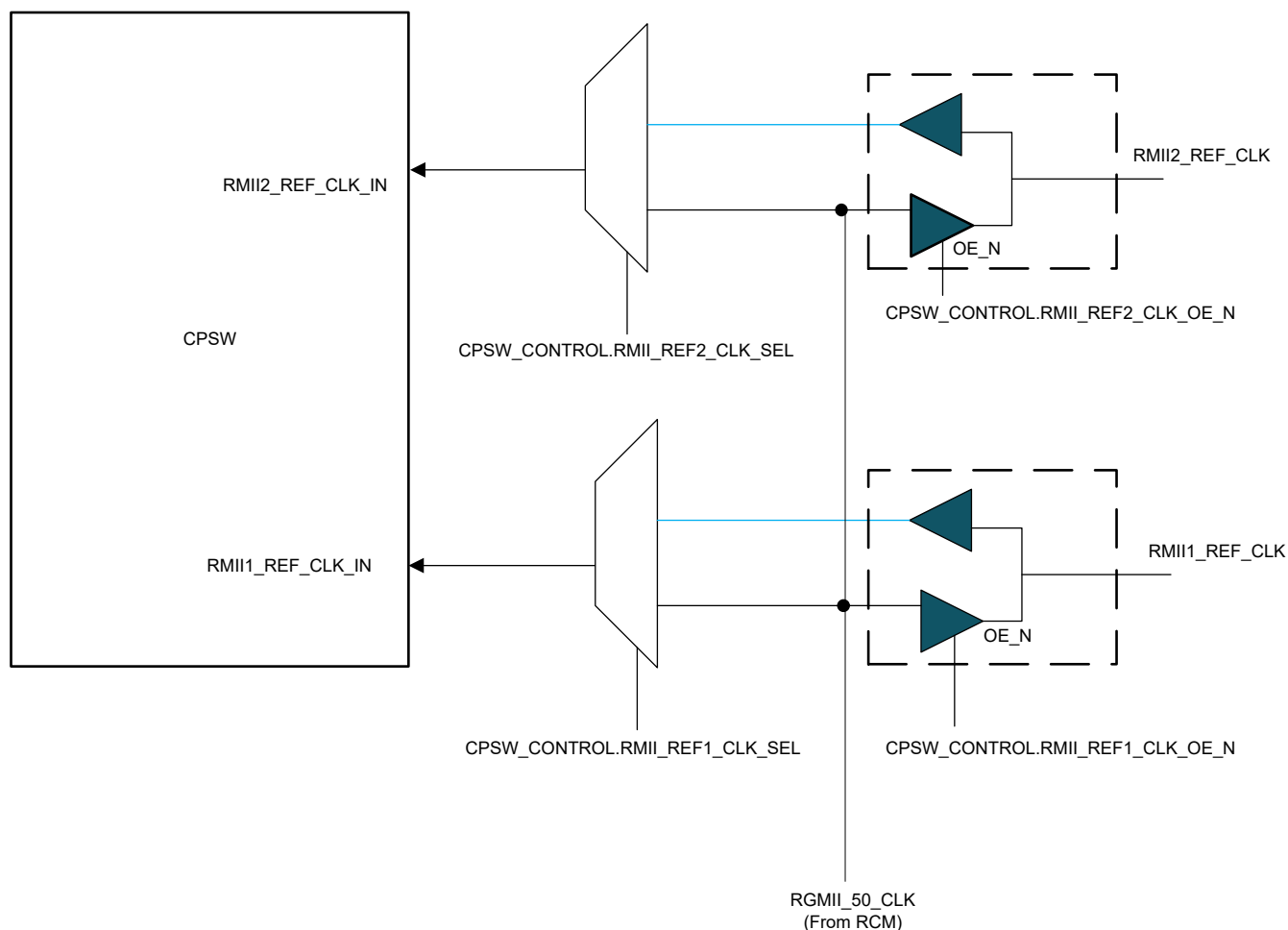

Figure 6-3. CPSW Configuration

6.1.1.2.2.6 ICSSM Global Configuration

The ICSSM_IDLE_CONTROL register enables dynamic power saving in ICSSM IP. When ICSSM_IDLE_CONTROL.NOGATE is programmed to '0', it enables auto clock gating in ICSSM with increased access latency. When this bit is programmed to '1', the clock is continuously active with low latency access.

The GPI signals of ICSSM can be sourced either from device pins or from PWM_XBAR . This selection can be done on a per signal granularity using the registers ICSSM_PRU*_GPI_SEL, as shown in Figure 6-4.

When the pinmux is configured to choose ICSSM GPIO function (PR0_PRU*_GPIO*), the control of the output buffer of the device pin can be done using the registers ICSSM_PRU*_GPIO_OUT_CTRL, as shown in Figure 6-4.

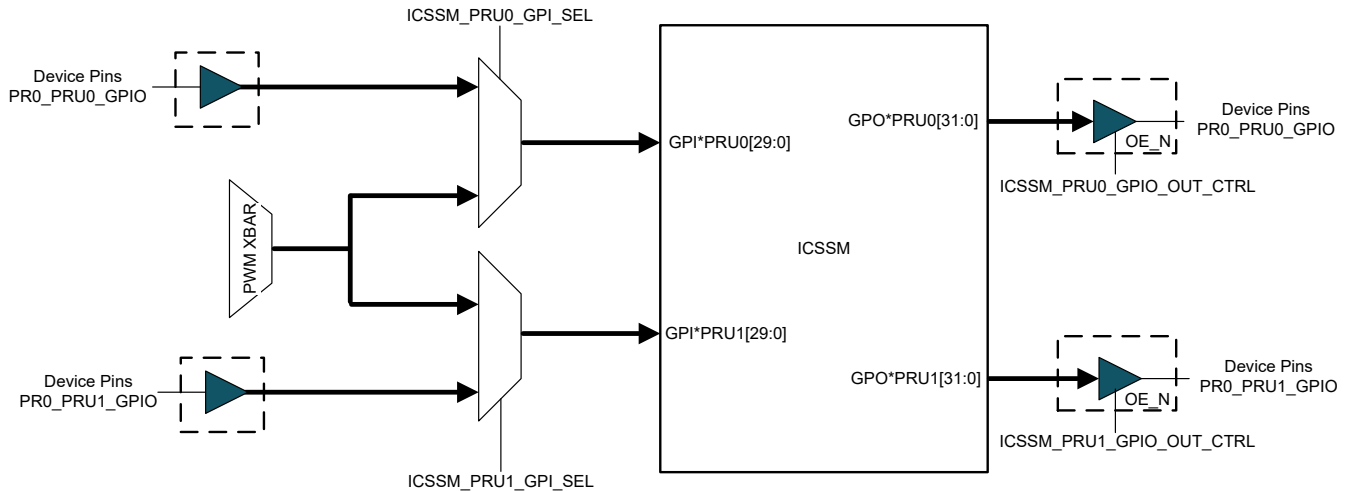

Note: Not all GPI and GPO signals of ICSSM are available on Device spins. Refer to device specific data sheet for the signals available on pinmux.

Figure 6-4. ICSSM Configuration

6.1.1.2.2.7 GPMC Global Configuration

The register GPMC_CONTROL configures the GPMC I/O clock source and GPMC feedback clock source, as shown in Figure 6-5.

GPMC_CONTROL.CLKOUT_SEL, when programmed to 0, selects the GPMC_FUNC_CLK from RCM as the I/O clock GPMC_CLK at the device pin. If a free running clock is desired at the device pin, the application must program this bit field to 0.

GPMC_CONTROL.CLKOUT_SEL, when programmed to 1, selects the divided clock from GPMC module as the I/O clock GPMC_CLK. In this case, the I/O clock is not free running and is only active during GPMC I/O transfers.

GPMC_CONTROL.CLK_LB_SEL configures the source of I/O loop back clock. Based on the system, timing, and noise careabouts, the application can configure the I/O loop back clock.

GPMC_CONTROL.CLK_OE_N and GPMC_CONTROL.CLK_LB_OE_N enable the output I/O buffer of GPMC_CLK and GPMC_LB_CLK.

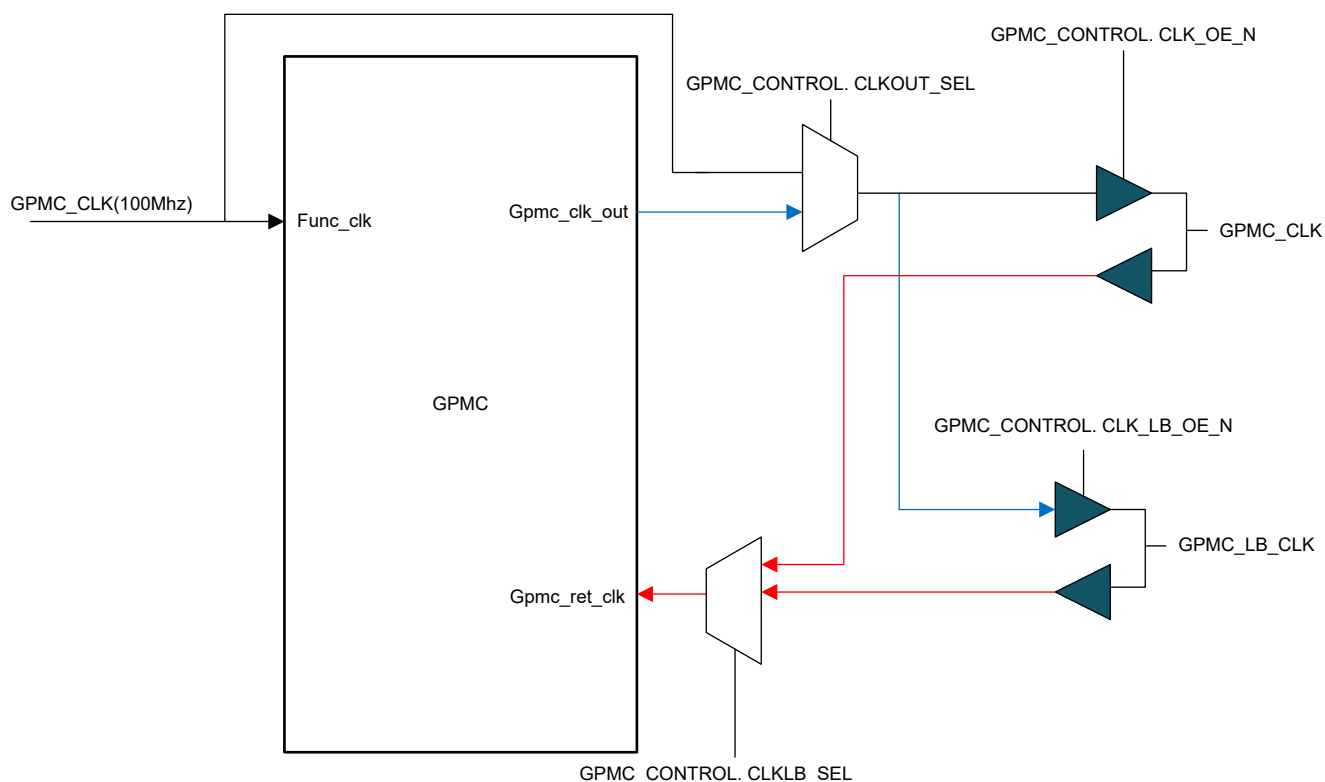

Figure 6-5. GPMC Configuration

6.1.1.2.2.8 MPU Interrupt Aggregator

The memory protection units (MPUs) present on various module ports each generate two kinds of error: an address error and a protection error. Refer to the MPU section for a description of these errors.

The address errors from all MPUs are aggregated and generate one interrupt R5SS*_CORE*_MPU_ADDR_ERRAGG to each R5 Core. Similarly, the protection errors from all MPUs are aggregated and generate one interrupt R5SS*_CORE*_MPU_PROT_ERRAGG to each R5.

The interrupt to each R5 can be independently configured to select the MPU sources, which should generate the above interrupts.

The registers MPU_ADDR_ERRAGG_R5SS*_CPU*_MASK, MPU_ADDR_ERRAGG_R5SS*_CPU*_STATUS, and MPU_ADDR_ERRAGG_R5SS*_CPU*_STATUS_RAW are associated with R5SS*_CORE*_MPU_ADDR_ERRAGG interrupt to the respective CPU.

The register MPU_ADDR_ERRAGG_R5SS*_CPU*_MASK configures interrupt sources which can generate the ADDR_ERR interrupt to the respective R5 core. MPU_ADDR_ERRAGG_R5SS*_CPU*_STATUS register indicates the status of the source which caused the ADDR_ERR interrupt to the respective R5 Core.

The MPU_ADDR_ERRAGG_R5SS*_CPU*_STATUS_RAW register indicates the raw status of all possible interrupt sources which can generate the ADDR_ERR interrupt.

The registers MPU_PROT_ERRAGG_R5SS0_CPU0_MASK, MPU_PROT_ERRAGG_R5SS0_CPU0_STATUS, and MPU_PROT_ERRAGG_R5SS0_CPU0_STATUS_RAW are associated with R5SS*_CORE*_MPU_PROT_ERRAGG interrupt to the respective CPU.

The register MPU_PROT_ERRAGG_R5SS0_CPU0_MASK configures interrupt sources, which can generate the PROT_ERR interrupt to the respective R5 core. MPU_PROT_ERRAGG_R5SS0_CPU0_STATUS register indicates the status of source which caused the PROT_ERR interrupt to the respective R5 Core.

The MPU_PROT_ERRAGG_R5SS0_CPU0_STATUS_RAW register indicates the raw status of all possible interrupt sources which can generate the PROT_ERR interrupt.

6.1.1.2.2.9 MMR Access Error Interrupt Aggregator

Some of the SOC control modules generate MMR access errors. Refer to the respective MMR section for the description of the error.

All MMR access errors are aggregated and generate a single interrupt `MMR_ACCESS_ERRAGGR` to the R5 Cores. The registers `MMR_ACCESS_ERRAGG_MASK0`, `MMR_ACCESS_ERRAGG_STATUS0`, and `MMR_ACCESS_ERRAGG_STATUS_RAW0` are associated with this interrupt.

The `MMR_ACCESS_ERRAGG_MASK0` register selects the sources which can generate the `MMR_ACCESS_ERRAGGR` interrupt. The `MMR_ACCESS_ERRAGG_STATUS0` register indicates the status of interrupt sources which caused the `MMR_ACCESS_ERRAGGR` interrupt to occur. The `MMR_ACCESS_ERRAGG_STATUS_RAW0` register indicates the raw status of all interrupt sources which can cause `MMR_ACCESS_ERRAGGR` interrupt to occur.

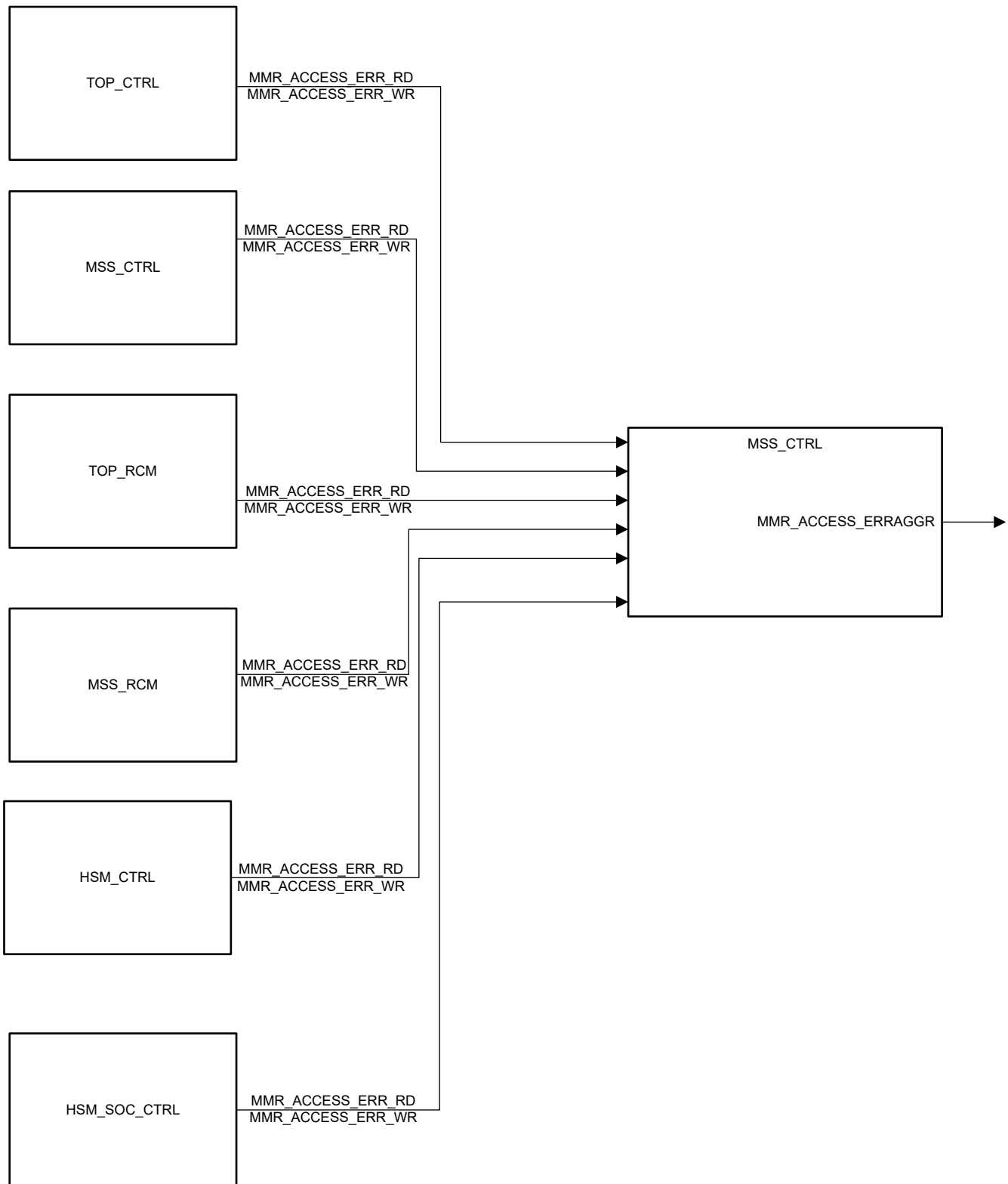

Figure 6-6. MMR Access Error Interrupt Aggregator

6.1.1.2.2.10 Safety Registers

6.1.1.2.2.10.1 R5 Memory ECC Error Aggregator

ARM R5 Cores support ECC error detection on the R5 associated memories – Icache, DCache, and TCM memories. These errors are visible on the ARM Event bus EVNTBUS[*]. These errors are aggregated in the Control module and presented as two errors to ESM per R5 Core:

- R5SS*_CORE*_CORR_ERRAGG : Correctable ECC Errors, one per R5 Core
- R5SS*_CORE*_UNCORR_ERRAGG : Uncorrectable/Fatal ECC Errors, one per R5 Core

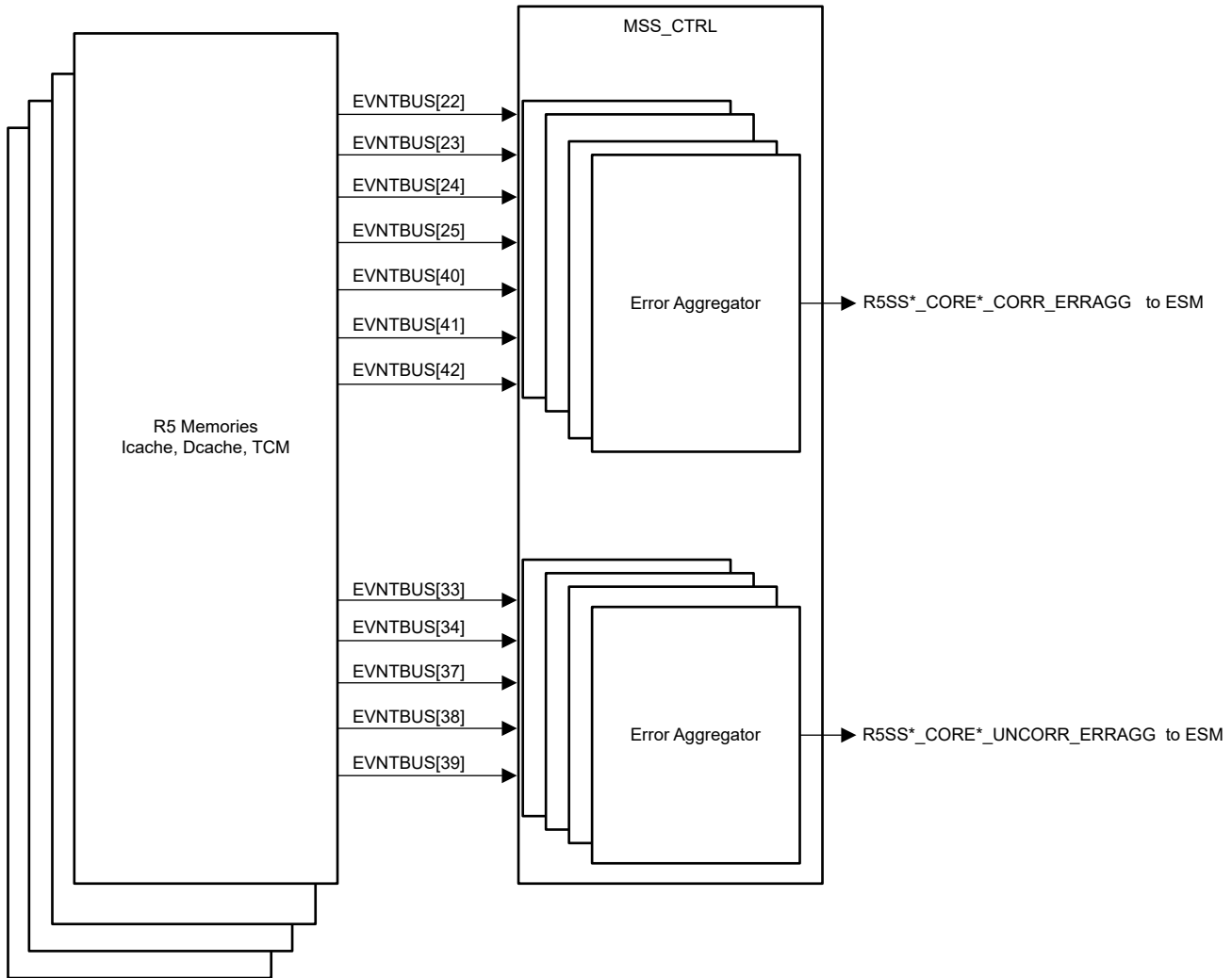

The following registers are associated with R5SS*_CORE*_CORR_ERRAGG:

- R5SS*_CPU*_ECC_CORR_ERRAGG_MASK – Error Mask Register
- R5SS*_CPU*_ECC_CORR_ERRAGG_STATUS – Error Status Register/Clear Register
- R5SS*_CPU*_ECC_CORR_ERRAGG_STATUS_RAW – Raw Error Status Register

Table 6-9 lists the events which can generate R5SS*_CORE*_CORR_ERRAGG Error.

Table 6-9. R5SS*_CORE*_CORR_ERRAGG Error Events

Event Flag	Event Mask	Description
R5SS*_CPU*_ECC_CORR_ERRAGG_STAT US[0]	R5SS*_CPU*_ECC_CORR_ERRAGG_MAS K[0]	EVNTBUS[40] ATCM single-bit ECC error.
R5SS0_CPU0_ATCM_CORR_ERR	R5SS0_CPU0_ATCM_CORR_ERR	

Table 6-9. R5SS*_CORE*_CORR_ERRAGG Error Events (continued)

Event Flag	Event Mask	Description
R5SS*_CPU*_ECC_CORR_ERRAGG_STAT US[1] R5SS0_CPU0_B1TCM_CORR_ERR	R5SS*_CPU*_ECC_CORR_ERRAGG_MAS K[1] R5SS0_CPU0_B1TCM_CORR_ERR	EVNTBUS[42] B1TCM single-bit ECC error.
R5SS*_CPU*_ECC_CORR_ERRAGG_STAT US[2] R5SS0_CPU0_B0TCM_CORR_ERR	R5SS*_CPU*_ECC_CORR_ERRAGG_MAS K[2] R5SS0_CPU0_B0TCM_CORR_ERR	EVNTBUS[41] B0TCM single-bit ECC error.
R5SS*_CPU*_ECC_CORR_ERRAGG_STAT US[3] R5SS0_CPU0_DTAG_CORR_ERR	R5SS*_CPU*_ECC_CORR_ERRAGG_MAS K[3] R5SS0_CPU0_DTAG_CORR_ERR	EVNTBUS[24] Data cache tag or dirty RAM parity error or correctable ECC error,
R5SS*_CPU*_ECC_CORR_ERRAGG_STAT US[4] R5SS0_CPU0_DDATA_CORR_ERR	R5SS*_CPU*_ECC_CORR_ERRAGG_MAS K[4] R5SS0_CPU0_DDATA_CORR_ERR	EVNTBUS[25] Data cache data RAM parity error or correctable ECC error.
R5SS*_CPU*_ECC_CORR_ERRAGG_STAT US[5] R5SS0_CPU0_ITAG_CORR_ERR	R5SS*_CPU*_ECC_CORR_ERRAGG_MAS K[5] R5SS0_CPU0_ITAG_CORR_ERR	EVNTBUS[22] Instruction cache tag RAM parity or correctable ECC error.
R5SS*_CPU*_ECC_CORR_ERRAGG_STAT US[6] R5SS0_CPU0_IDATA_CORR_ERR	R5SS*_CPU*_ECC_CORR_ERRAGG_MAS K[6] R5SS0_CPU0_IDATA_CORR_ERR	EVNTBUS[23] Instruction cache data RAM parity or correctable ECC error.

The following registers are associated with R5SS*_CORE*_UNCORR_ERRAGG:

- R5SS0_CPU0_ECC_UNCORR_ERRAGG_MASK – Error Mask Register
- R5SS0_CPU0_ECC_UNCORR_ERRAGG_STATUS – Error Status Register/Clear Register
- R5SS0_CPU0_ECC_UNCORR_ERRAGG_STATUS_RAW – Raw Error Status Register

Table 6-10 lists the events which can generate R5SS*_CORE*_UNCORR_ERRAGG Error.

Table 6-10. R5SS*_CORE*_UNCORR_ERRAGG Error Events

Event Flag	Event Mask	Description
R5SS0_CPU0_ECC_UNCORR_ERRAGG_S TATUS[0] R5SS0_CPU0_ATCM_UNCORR_ERR	R5SS0_CPU0_ECC_UNCORR_ERRAGG_ MASK[0] R5SS0_CPU0_ATCM_UNCORR_ERR	EVNTBUS[37] ATCM multi-bit ECC error.
R5SS0_CPU0_ECC_UNCORR_ERRAGG_S TATUS[1] R5SS0_CPU0_B1TCM_UNCORR_ERR	R5SS0_CPU0_ECC_UNCORR_ERRAGG_ MASK[1] R5SS0_CPU0_B1TCM_UNCORR_ERR	EVNTBUS[39] B1TCM multi-bit ECC error
R5SS0_CPU0_ECC_UNCORR_ERRAGG_S TATUS[2] R5SS0_CPU0_B0TCM_UNCORR_ERR	R5SS0_CPU0_ECC_UNCORR_ERRAGG_ MASK[2] R5SS0_CPU0_B0TCM_UNCORR_ERR	EVNTBUS[38] B0TCM multi-bit ECC error
R5SS0_CPU0_ECC_UNCORR_ERRAGG_S TATUS[3] R5SS0_CPU0_DTAG_UNCORR_ERR	R5SS0_CPU0_ECC_UNCORR_ERRAGG_ MASK[3] R5SS0_CPU0_DTAG_UNCORR_ERR	EVNTBUS[34] Data cache tag/dirty RAM fatal ECC error
R5SS0_CPU0_ECC_UNCORR_ERRAGG_S TATUS[4] R5SS0_CPU0_DDATA_UNCORR_ERR	R5SS0_CPU0_ECC_UNCORR_ERRAGG_ MASK[4] R5SS0_CPU0_DDATA_UNCORR_ERR	EVNTBUS[33] Data cache data RAM fatal ECC error

6.1.1.2.10.2 R5SS TCM Address Parity Error Aggregator

The R5 CPU can generate parity bits on the TCM address. R5SS implements a parity error detection mechanism and generates an error event if parity error is detected. These errors are aggregated in Control module and presented as one Error per R5 to the ESM module - R5SS*_CORE*_TCM_ADDRPARITY_ERRAGG.

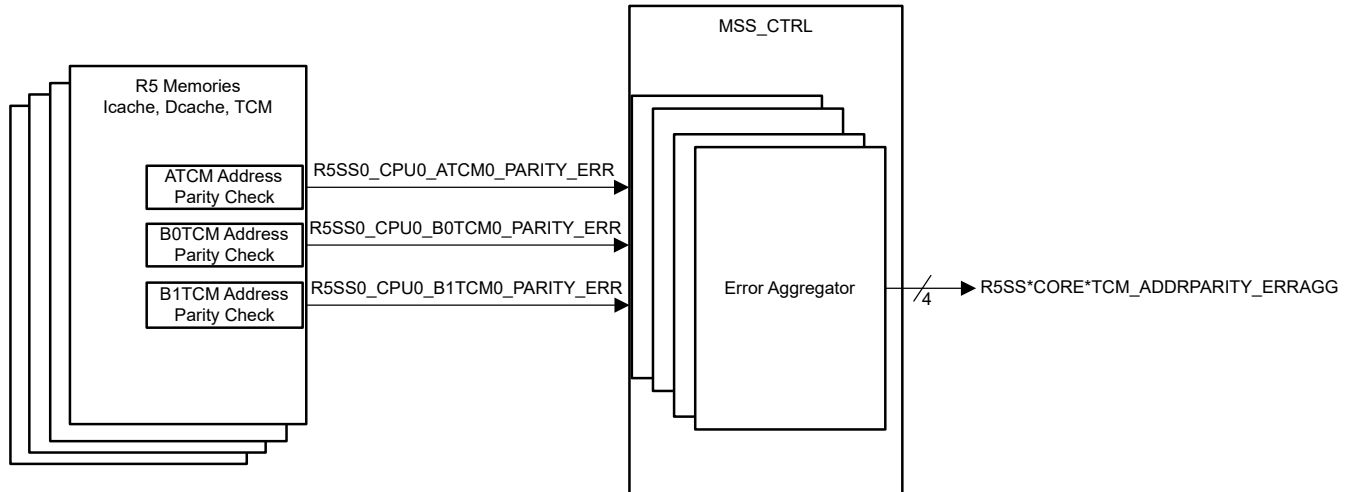

Figure 6-7. R5SS TCM Address Parity Error Aggregator

The following registers are associated with R5SS*CORE*TCM_ADDRPARITY_ERRAGG:

- R5SS*_CPU*_ECC_CORR_ERRAGG_MASK – Error Mask register
- R5SS*_CPU*_ECC_CORR_ERRAGG_STATUS - Error Status Register/Clear Register
- R5SS*_CPU*_ECC_CORR_ERRAGG_STATUS_RAW – Raw error status register
- R5SS*_CORE*_ADDRPARITY_ERR_ATCM – Latched Address of Parity Error location on ATCM Memory of respective R5 Core
- R5SS*_CORE*_ERR_ADDRPARITY_B0TCM - Latched Address of Parity Error location on B0TCM Memory of respective R5 Core
- R5SS*_CORE*_ERR_ADDRPARITY_B1TCM - Latched Address of Parity Error location on B1TCM Memory of respective R5 Core
- R5SS*_TCM_ADDRPARITY_CLR - Parity Error Address clear register for respective R5SS

Table 6-11 lists the events which can generate R5SS*CORE*TCM_ADDRPARITY_ERRAGG.

Table 6-11. R5SS*CORE*TCM_ADDRPARITY_ERRAGG Events

Event Flag	Event Mask	Description
R5SS0_CPU0_TCM_ADDRPARITY_ERRAGG_STATUS [0] ATCM0_PARITY_ERR	R5SS0_CPU0_TCM_ADDRPARITY_ERRAGG_MASK [0] ATCM0_PARITY_ERR	ATCM Address Parity Error
R5SS0_CPU0_TCM_ADDRPARITY_ERRAGG_STATUS [1] B0TCM0_PARITY_ERR	R5SS0_CPU0_TCM_ADDRPARITY_ERRAGG_MASK [1] B0TCM0_PARITY_ERR	B0TCM Address Parity Error
R5SS0_CPU0_TCM_ADDRPARITY_ERRAGG_STATUS [2] B1TCM1_PARITY_ERR	R5SS0_CPU0_TCM_ADDRPARITY_ERRAGG_MASK [2] B1TCM0_PARITY_ERR	B1TCM Address Parity Error

6.1.1.2.2.11 Interconnect Safety

6.1.1.2.2.12 CTRLMMR1 MMR Kick Protection Registers

The CTRLMMR1 memory space is divided into several partitions. The partition 0 is associated with the Kick register, which is described in this section.

The CTRLMMR1 module has a protection mechanism which prevents spurious writes from changing the values of its registers. The LOCKi_KICK0 and LOCKi_KICK1 registers are used for this purpose. A write is required first to the LOCKi_KICK0[31-1] KEY field and then to the LOCKi_KICK1[31-0] KEY field with exact data values to unlock the protection mechanism. When released, all registers within Partition "i" having write permissions can be written to. The read only registers remain read only. An indication for unlocked Partition "i" is when the

LOCKi_KICK0[0] bit is set to 1h. When the protection mechanism is locked (indicated by LOCKi_KICK0[0] = 0h), none of the registers within Partition "i" can be written to. They can only be read.

Table 6-12 shows the values that must be written to the LOCKi_KICK0 and LOCKi_KICK1 registers to unlock each partition. Writing any other data value to either of these registers locks the protection mechanism and blocks any writes to the registers that reside in Partition "i".

Table 6-12. CTRLMMR1 MMR Kick Protection Registers

Register	Partition	Unlock Value
LOCK0_KICK0	Partition 0	01234567h
LOCK0_KICK1	Partition 0	FEDCBA8h

Note

To ensure that all registers from a given partition are write protected, software must always re-lock the protection mechanism after completing the register writes.

The kick protection registers described in this section are an exception and are not write protected by the protection mechanism.

6.1.1.2.2.13 CTRLMMR1 MMR Access Error

The CTRLMMR1 module can generate an Access Error interrupt which is associated with the following registers.

- INTR_RAW_STATUS - Interrupt Raw Status/Set register
- INTR_ENABLED_STATUS_CLEAR - Interrupt Enabled Status/Clear register
- INTR_ENABLE - Interrupt Enable register
- INTR_ENABLE_CLEAR - Interrupt Enable Clear register

The following applies for the interrupt behavior of the CTRLMMR1 module:

- The CTRLMMR1 module only asserts the interrupt line if enabled.
 - Interrupts are **enabled** by setting the corresponding bits in the INTR_ENABLE register to 1h.
 - Interrupts are **disabled** by setting the corresponding bits in the INTR_ENABLE_CLEAR register to 1h.
- After an interrupt has been serviced, software must clear the corresponding status flag. This is done by setting to 1h the corresponding bit in the INTR_ENABLED_STATUS_CLEAR register which also clears the corresponding bit in the INTR_RAW_STATUS register. The status flags in the INTR_RAW_STATUS register are set even if the corresponding interrupt is disabled. The INTR_ENABLED_STATUS_CLEAR register, is only set if the corresponding interrupt is enabled.
- An interrupt is generated by the CTRLMMR1 if relevant bit in the INTR_RAW_STATUS register is set to 1h and the interrupt is enabled through the INTR_ENABLE register. This feature is useful during user software debugging. In addition, even if interrupts are disabled, the corresponding raw flag in the INTR_RAW_STATUS register is set to 1h when an IRQ condition occurs.
- If interrupts are disabled, the corresponding raw flag in the INTR_RAW_STATUS register is set to 1h when an IRQ condition occurs. The INTR_RAW_STATUS can be cleared by setting the corresponding bit in the INTR_RAW_STATUS register to 1h.

Table 6-13 lists the interrupt events which can assert the CTRLMMR1 Access Error.

Table 6-13. CTRLMMR1 Access Error Interrupt Events

Event Flag	Event Mask	Description
INTR_RAW_STATUS[2] KICK_ERR	INTR_ENABLE[2] KICK_ERR_EN	Lock violation interrupt.
INTR_ENABLED_STATUS_CLE AR[2] ENABLED_KICK_ERR	INTR_ENABLE_CLEAR[2] KICK_ERR_EN_CLR	Occurs when writing to a register in a locked CTRLMMR1 partition.

Table 6-13. CTRLMMR1 Access Error Interrupt Events (continued)

Event Flag	Event Mask	Description
INTR_RAW_STATUS[1] ADDR_ERR	INTR_ENABLE[1] ADDR_ERR_EN	Addressing violation interrupt. Occurs when accessing an illegal address inside the CTRLMMR1 module.
INTR_ENABLED_STATUS_CLR AR[1] ENABLED_ADDR_ERR	INTR_ENABLE_CLEAR[1] ADDR_ERR_EN_CLR	

When an error event as described in Table above occurs, the error associated details are captured in the FAULT_ADDRESS, FAULT_TYPE_STATUS, FAULT_ATTR_STATUS registers.

FAULT_ADDRESS contains the address of the first fault access. FAULT_TYPE_STATUS and FAULT_ATTR_STATUS contain status attributes associated with the first fault access. To clear the contents of these three registers and allow them to latch the attributes of the next fault the FAULT_CLEAR[0] FAULT_CLR bit must be set to 1h.

6.2 Power

This chapter describes the power-management architecture implemented in the device.

The Power Management content is presented in several general sections:

- Power Management Subsystems (System and Control Modules)
- Device Power States
- Dynamic and Thermal Management

6.2.1 Power Management Overview	181
6.2.2 Power System Modules	181
6.2.3 Power Control Modules	189
6.2.4 Device Power States	190

6.2.1 Power Management Overview

The chip consists of four voltage rails. There are two main external power supply for the device (3.3V and 1.2V). The external supply can be independently ramped up. Two additional 1.8V rails are generated by internal LDO.

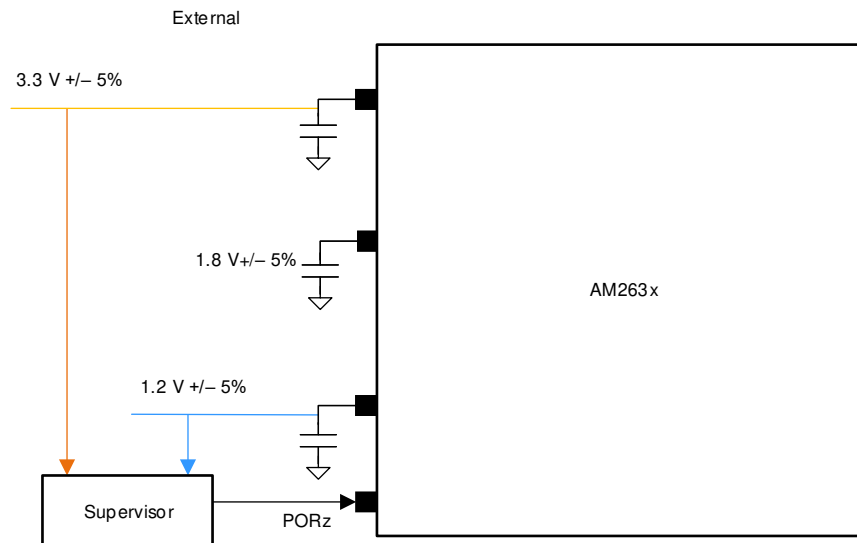

Figure 6-8. AM263x Power Overview

The device consists of the following power supply modules

- BGAP – Reference voltage source for all voltage regulators and VREF's
- IO BIAS – To remove the requirement of supply sequence of IO by generating a 1.8V bias supply to IO from 3.3V
- 1.8V LDO – To generate 1.8V supply to analog modules from 3.3V
- Voltage Monitors – VMONs shall be implemented on following supplies:
 - VDD 1.2V
 - VDDA 1.8V
 - VDDS 3.3V
 - External supply monitor
 - IO BIAS
 - Reference Voltages
- POR – Delay the external input reset to the logic until the VDDA 1.8V is within threshold. Generate isolation signals HHV.
- Thermal Manager (TM) module to monitor the device temperature.

The device supports clock control on all IP clocks. Unused clocks can be gated off by software to save power. See [clock chapter](#) for details

The On-Chip Static Random Access Memory (OCSRAM) banks can be powered down to save power. See section L2OCRAM power control.

Device power states are defined based on the state of external supply, as described in [Device Power States](#).

Additional hardware modules for temperature sensing, thermal management, power monitoring, and reset functions related to power-on sequencing, are described in [Power System Modules](#).

6.2.2 Power System Modules

6.2.2.1 Power OK (POK) Modules

POK modules are responsible for accurately detecting the voltage levels. Each module is trimmed to account for process and temperature variations. The trim values are provided by eFuse chains enabled by a POR module.

During POR, coarse monitors on supplies VDDA18, VDD12, 1.8V LDO, BGAP are enabled. The status of this can be monitored through TOP_CTRL.PMU_COARSE_STAT register during runtime.

The table below shows different voltage monitors available. Enabling/Disabling of this monitors can be controlled by TOP_CTRL.VMON_CTRL, TOP_CTRL.ADC_REF_COMP_CTRL register. There are corresponding status bits available in TOP_CTRL.VMON_STAT, TOP_CTRL.ADC_REF_GOOD_STATUS. The output of voltage monitors comparators are filtered using a configurable digital glitch filter module. The configuration of filter can be done using TOP_CTRL.VMON_FILTER_CTRL.SELECT_VALUE to select from no filtering option to max of 14.4us filtering of voltage monitor signals. The output of the voltage monitors are aggregated and the aggregated output is forward to ESM. Individual mask bits in TOP_CTRL.MASK_VMON_ERROR_ESM_L and TOP_CTRL.MASK_VMON_ERROR_ESM_H can be used to MASK the corresponding monitor to trigger ESM event.

POK is set to 1 when the voltage supply is within the range and goes to 0 when out of range. See device datasheet for POK tolerance.

The ESM event is generated only when POK signals out of range.

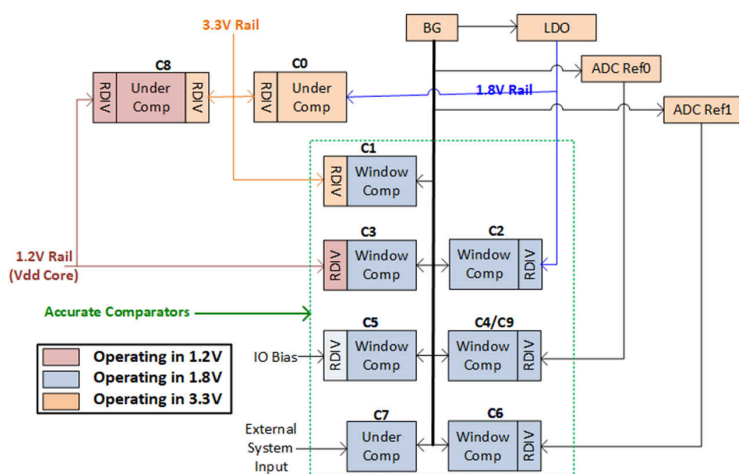

Figure 6-9. Voltage Comparator subsystem

Table 6-14. POK Module overview

Voltage Monitored	Comparator block	UV/OV ⁽¹⁾	Description
VDDA18	C0	UV	Voltage monitor for 1.8V LDO output using 3.3V as reference
VDDA18	C2	UV/OV	Voltage monitor for 1.8V LDO output using BGAP as reference
VBGAP09	C1	UV/OV	Voltage monitor for 0.9V bandgap.
VDD12	C3	UV/OV	Voltage monitor for 1.2V I/O supply
VDDSBIO	C5	UV/OV	Voltage monitor for 1.8V IO bias supply
VSYS_MON	C7	UV	Voltage monitor for external VSYS_MON
VDDA33	C8	UV	Voltage monitor for 3.3V I/O supply
ADC0_REF	C4	UV/OV	Voltage monitor for ADC0_REF
ADC12_REF	C9	UV/OV	Voltage monitor for ADC12_REF

ADVANCE INFORMATION

Table 6-14. POK Module overview (continued)

Voltage Monitored	Comparator block	UV/OV ⁽¹⁾	Description
ADC34_REF	C6	UV/OV	Voltage monitor for ADC34_REF

6.2.2.2 Power on Reset module

The device relies on an external supervisor to ensure that the device external supplies (3.3V, 1.2V) are within range before releasing the reset to the device (PORz pin). Once the PORz is deasserted, the LDO to generate 1.8V analog is enabled.

The POR module monitors internally 3.3V, 1.2V external power supply as well internal 1.8V LDO and 0.9V bandgap voltages before internal reset is released to the system.

6.2.2.3 Thermal Manager

This section describes the Thermal Manager (TM) module in the device.

The TM module on the AM263x enables thermal management of the device by providing control of on-chip temperature sensors.

The device has two temperature sensors, each located near critical hotspots in the device die. There are two additional temperature sensors at other locations in the device die.

Active temperature monitoring is available for two temperature sensors near the hotspots. The other two temperature sensors are only for temperature readout.

6.2.2.3.1 Thermal Manager Features

The Thermal Manager (TM) module supports the following features:

- Programming of temperature-crossing thresholds
- Signals when programed thresholds are exceeded (up to 3 alerts):
 - Temperature exceeding the TSENSE*_ALERT.ALERT_THRHLD_HOT for ALERT_HOT_INTR.
 - Temperature below the TSENSE*_ALERT.ALERT_THRHLD_COLD for ALERT_HOT_INTR
- Supports up to 4 temperature monitors.
- Allows resolution of 2°C for temperature reading and threshold point temperature alert/interrupt generation.
- Maximum temperature alert.
- Supports one shot sampling mode for the sensors.
- Temp sense controller loops cyclically through each sensor and generates the results. Each sensor can be enabled/disabled independently.
- Provides register control and status for all 4 sensors. Interrupt generation, FIFO registers and alerts for 2 SOC temperature monitors.
- Default threshold are controlled through efuse values. This can be also controlled through programmable registers.
- There are four FIFOs used to store a brief history for the last few temperature measurements and are also dedicated to temperature time-stamping feature.
- Accumulator register for cumulative sum of past temperature measurements on 2 SOC temperature monitors.

6.2.2.3.2 Thermal Manager Functional Description

There are four temperature sensors on the device die. Each sensor is associated only with one voltage domain and is also a part of a VBGAPTS cell. This cell has a 7-bit ADC. The ADC converts the temperature values into digital output values proportional to the temperature measured. Each VBGAPTS cell is controlled by a FSM referred to as thermal FSM. The registers associated with thermal manager reside in the TOP_CTRL module.

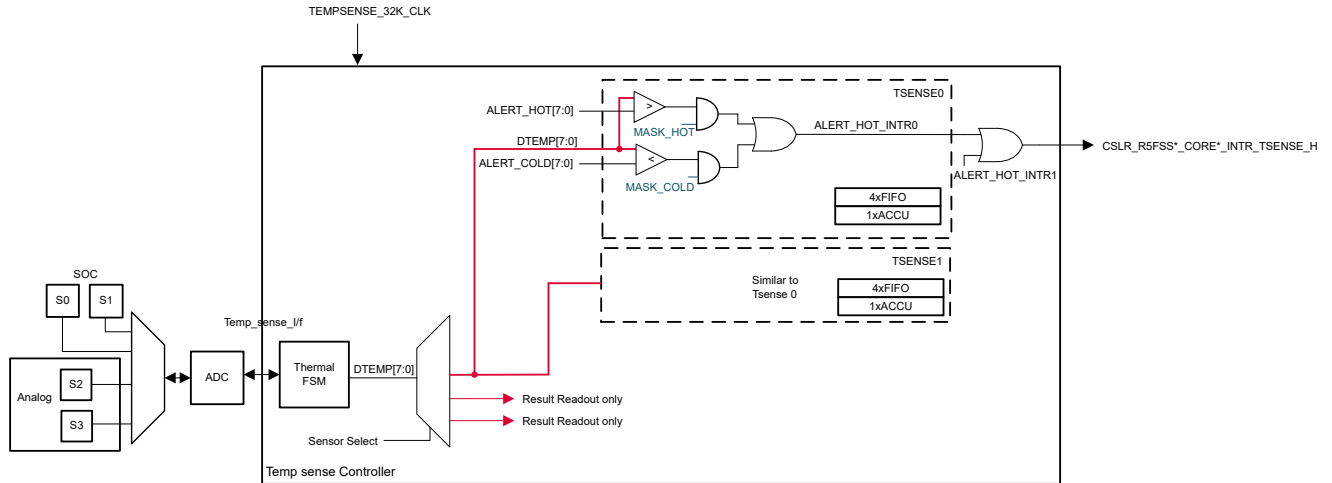

Figure 6-10. Thermal Management Functional Block Diagram

6.2.2.3.3 Thermal FSM

Thermal FSM is clocked by the TEMPSENSE_32K_CLK clock. At reset the FSM is not enabled. The main control register is TOP_CTRL.TSENSE_CFG. In order to enable temperature controller, below bits needs to be reset TMPSOFF, BGRÖFF, AIPOFF and SNSR_MX_HIZ bit.

The thermal FSM does read out of sensors in round robin fashion. SENSOR_SEL controls the enabling/disabling of individual sensors.

The start of temperature measurement is initiated automatically after the TOP_CTRL.TSENSE_CFG.ENABLE is set.

For each selected sensor, FSM requires anywhere between 51 to 54 clock cycles to start the sequence and register the result into TOP_CTRL.TSENSE*_RESULT. TOP_CTRL.TSENSE_CFG.DELAY configures the no. of clock cycles between end of result captured to FSM starting the sequence for the next enabled sensor. When the conversion is ongoing for a particular sensor, the corresponding TOP_CTRL.TSENSE*_RESULT.EOCZ status bits are set to 0x1. The EOCZ bit is reset to 0 again when the conversion completes. After this the valid temperature is written automatically by FSM in the TOP_CTRL.TSENSE*_RESULT.DTEMP bit fields, and then software is able to read it from the corresponding register.

Below flow chart describes the sequence of sensor measurement based on SENSOR_SEL bits.

Note

Value 0 in TOP_CTRL.TSENSE_CFG.DELAY is not valid. A non-zero value should be programmed to this register.

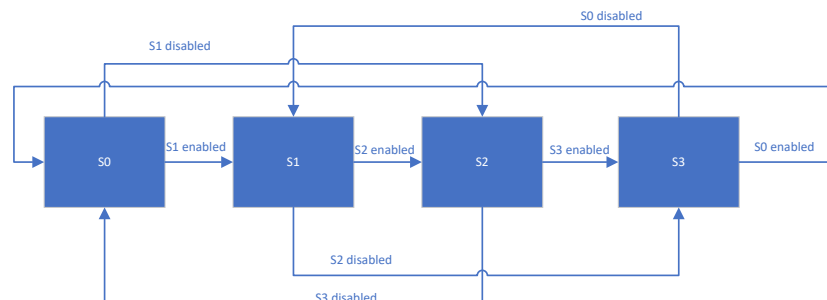

Figure 6-11. Sensor flow diagram

6.2.2.3.4 Thermal Alert Comparator

There is a comparator block responsible for the thermal alert function of the thermal management logic. The thermal comparator block is composed of a single comparator. It checks temperature above the high temperature threshold.

The masked signal is also routed to the `TOP_CTRL.TSENSE_STATUS`.

The non masked (raw) comparator outputs are available for reading through the corresponding bits in the `TOP_CTRL.TSENSE_STATUS_RAW`.

6.2.2.3.5 Temperature Timestamp Registers

Each time one of the `TOP_CTRL.TSENSE*_RESULT.DTEMP` bit fields is updated with new temperature value, this value is also automatically stored into a 4-level deep FIFO and a timestamp is registered too. There are four FIFOs used to store a brief history for the last few temperature measurements and are also dedicated to temperature timestamping feature. Each FIFO has two fields.

The first one is 8 bits wide, 4 levels deep, and is intended to store the temperature values for the last four measurements. The second field is 22 bits wide, 4 levels deep, and acts like a counter for the number of temperature measurements. Each FIFO is composed of the following registers:

- `TSENSE0_DATA0`
- `TSENSE0_DATA1`

- TSENSE0_DATA2
- TSENSE0_DATA3

6.2.2.3.6 FIFO Management

Software can stop a certain FIFO to update with new temperature and timestamp values when setting to 0x1 one of the FREEZE bits in the TOP_CTRL.TSENSE0_CNTL and TOP_CTRL.TSENSE1_CNTL registers. These FIFO_FREEZE bits are automatically cleared by hardware after the FIFOs are cleared.

Each FIFO is cleared by setting to 0x1 one of the FIFO_CLEAR bits in the TOP_CTRL.TSENSE0_CNTL and TOP_CTRL.TSENSE1_CNTL registers. These FIFO_CLEAR bits are also automatically set by hardware to 0x0 after the FIFOs clearing procedure completes.

Additionally TOP_CTRL.TSENSE0_ACCU and TOP_CTRL.TSENSE1_ACCU registers store the accumulated temperature values. This are cleared by setting to 0x1 one of the ACCU_CLEAR bits in the TOP_CTRL.TSENSE0_CNTL and TOP_CTRL.TSENSE1_CNTL registers.

6.2.2.3.7 ADC Values Versus Temperature

Table 6-15 provides all the valid ADC values which correspond to the temperature measured which is read from the TOP_CTRL.TSENSE*_DATA*.DATA, TOP_CTRL.TSENSE*_RESULT.DTEMP bit fields. The table also provides the values for the temperature thresholds which are configurable through the TOP_CTRL.TSENSE*_ALERT.ALERT_THRHLD_COLD, TOP_CTRL.TSENSE*_ALERT.ALERT_THRHLD_HOT bit fields.

Table 6-15. ADC Values Versus Temperature

ADC code	Temperature	ADC code	Temperature	ADC code	Temperature
0-24	150	56	86	88	22
25	148	57	84	89	20
26	146	58	82	90	18
27	144	59	80	91	16
28	142	60	78	92	14
29	140	61	76	93	12
30	138	62	74	94	10
31	136	63	72	95	8
32	134	64	70	96	6
33	132	65	68	97	4
34	130	66	66	98	2
35	128	67	64	99	0
36	126	68	62	100	-2
37	124	69	60	101	-4
38	122	70	58	102	-6
39	120	71	56	103	-8
40	118	72	54	104	-10
41	116	73	52	105	-12
42	114	74	50	106	-14
43	112	75	48	107	-16
44	110	76	46	108	-18
45	108	77	44	109	-20
46	106	78	42	110	-22
47	104	79	40	111	-24
48	102	80	38	112	-26
49	100	81	36	113	-28

Table 6-15. ADC Values Versus Temperature (continued)

ADC code	Temperature	ADC code	Temperature	ADC code	Temperature
50	98	82	34	114	-30
51	96	83	32	115	-32
52	94	84	30	116	-34
53	92	85	28	117	-36
54	90	86	26	118	-38
55	88	87	24	119-128	-40

6.2.3 Power Control Modules

The Power Control Modules are divided into two section, dependent on their functionality - Clock ICG control section and L2OCRAM power control section.

6.2.3.1 Clock ICG controls

Clock ICG control manages the clock to each of the IPs using software control. For each module, there is a dedicated register <IP>_CLK_GATE part of MSS_RCM register space. By default all module clocks are enabled. Writing 0x7 into field GATED of corresponding <IP>_CLK_GATE will disable the clock to the IP.

Additionally, TOP_RCM host clock gating register R5SS0_CLK_GATE and R5SS1_CLK_GATE to disable core clock to individual R5SS. SYS_CLK_GATE disable SYS_CLK to the whole system. Not recommended to gate SYS_CLK as the system will hang and only option is to reset the whole system. TOP_RCM also allows clock gating for TRACE_CLK and CLKOUT0/CLKOUT1 ports.

6.2.3.2 L2OCRAM Power Control

There are 4 memory banks each of 512KB available as L2OCRAM. By default all of this banks are in Power ON.

Individual L2OCRAM banks can be powered OFF using software writes to MSS_RCM.L2OCRAM_BANK*_PD_CTRL register and by observing status bits from MSS_RCM.L2OCRAM_BANK*_PD_STATUS

Sequence to power off each bank is captured below

1. Write 0x7 to ISO field of the register.
2. Write 0x0 to AONIN field of the register.
3. Wait till AONOUT status field is 0x0.
4. Write 0x0 to AGOODIN field of the register.
5. Wait till AGOODOUT status field is 0x0.

Sequence to Power On each bank is capture below

1. Write 0x7 to AONIN field of the register.
2. Wait till AONOUT status field is 0x1.
3. Write 0x7 to AGOODIN field of the register.
4. Wait till AGOODOUT field is 0x1.
5. Write 0x0 to ISO field of the register.

When a block is powered off, a bus error is generated on access.

Note

It is always safe to have decent delay between each step because memory might take some time before reaching to total power on state. So even though aonout is 1'b1 does not mean memory is ON.

6.2.4 Device Power States

6.2.4.1 Overview of Device Power Modes

The device supports multiple power modes described in the sections below. The lower power consumption comes at the cost of longer time for recovery to a running mode.

Figure 6-12 depicts the valid power modes for the device.

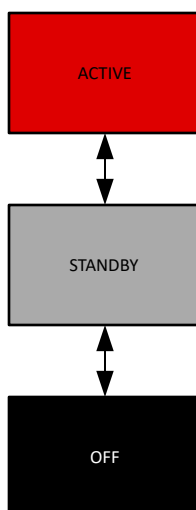

Figure 6-12. Power Modes

Device supports the following power states:

- **ACTIVE:** Main Status and Control registers are ON, processors and subsystems are ON, based on use cases.
- **STANDBY:** Main processor cores in WFI/WFE, rest of active subsystems idles.
- **OFF:** entire device is off by switching off voltage rails externally.

6.2.4.2 Device Power States and Transitions

The LPMs always transition from run state. If the device software decides to transition from one low power mode to another low power mode, it needs to go through the run state first.

Normally, the software initiates transition to low power mode and interrupts/events are the exit trigger.

shows the state diagram of transitions between LPMs.

This device supports three power states: OFF, ACTIVE, and STANDBY. STANDBY mode here is referred to for WFI/WFE execution from individual R5SS and clock gating enabled for all/required peripherals. Exit from Standby will restart the individual R5SS clocks but the IP clocks are not automatically switched ON. They need to be programmed in MSS_RCM.<IP>_CLK_GATE register to enable/disable. The transitioning schemes are as follows:

- OFF → ACTIVE
- STANDBY → ACTIVE
- ACTIVE → OFF
- ACTIVE → STANDBY

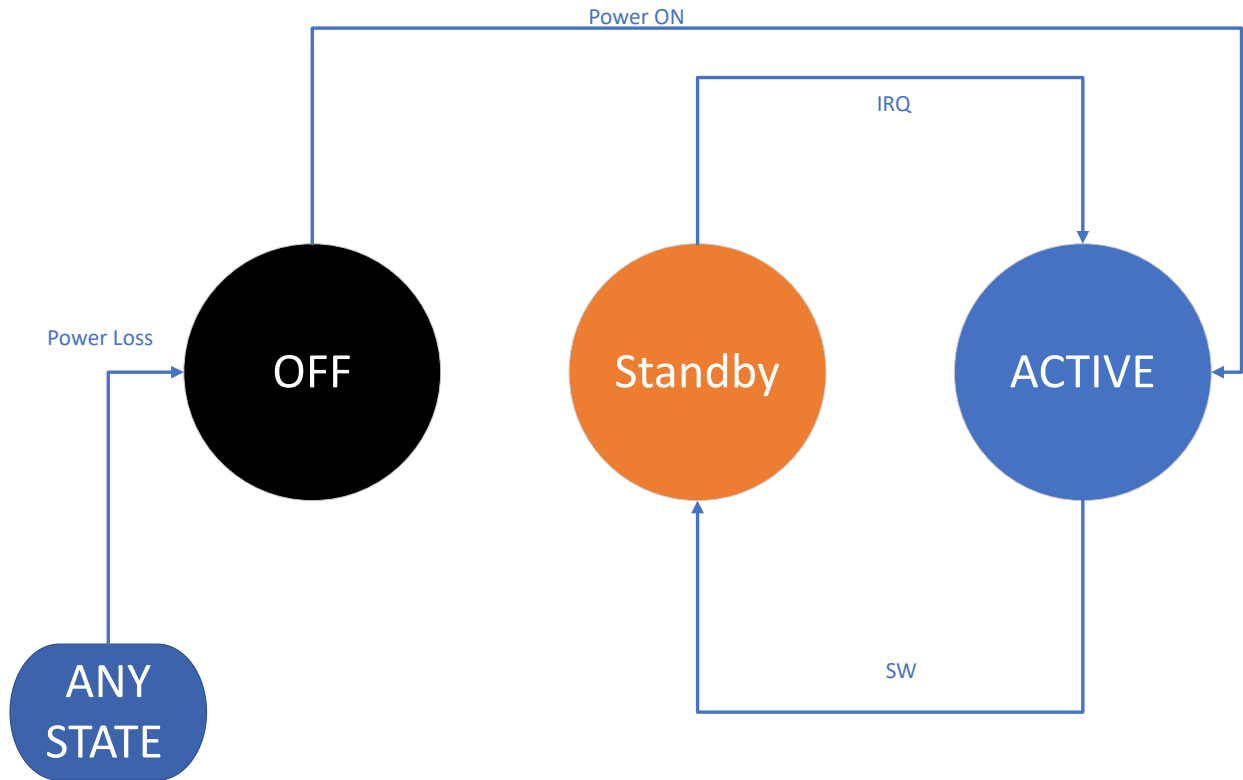

ADVANCE INFORMATION

Figure 6-13. Transition between Power Modes

6.3 Reset

This chapter describes the device reset signals and contains details on reset management.

6.3.1 Overview	193
6.3.2 Reset Sources	196
6.3.3 Reset Status	196
6.3.4 Reset Controls	198
6.3.5 Reset Details	199

6.3.1 Overview

Reset Introduction

A reset is designed to bring a device or subsystem into a known state. Resets occur after power up events, as well as software and hardware reset requests. This section introduces the device reset capabilities and functionality.

Device Resets

The device Power-on-Reset (POR) is controlled by the external pin PORz. This pin is driven by an external (off-chip) "Power-Good" Circuit or Power Management IC (PMIC). The PORz pin should be held active LOW (0) during the entire power-up phase. The device should be held in reset until all power supplies are stable with an additional a delay for the High Frequency Oscillator (HFOSC0) clock to stabilize. PORz will reset all the logic in the SoC without exception.

The device also supports the WARMRSTn signal. The device warm reset status is brought out on this pin to drive reset to external board components. Warm reset can also be triggered from outside SoC by asserting the WARMRSTn pin externally.

6.3.1.1 SoC Supported Resets

- Power-On-Resets
 - PORz HW Pin reset
- Warm Resets
 - RESETz_REQ (WARMRSTn) HW Pin
 - Watchdog time-out resets (4x/SoC + 1x/HSM)
 - TOP_RCM.WARM_RESET_REQ control registers warm reset
 - Debugger sysrst request
- Local Module Resets
 - RCM module local reset

6.3.1.2 Reset Terminology

POR	Power-On-Reset
ESM	Error signaling Module
VD	Voltage Domain
POK	Power OK
HHV	High Heating Value mode (IO Pin Fail-safe Control (Tri-State Output))
TM	Temperature Monitor

6.3.1.3 Reset Architecture

Reset Architecture Block Diagram

This is the device reset architecture block diagram. It describes the device reset submodules and critical internal signal interconnections.

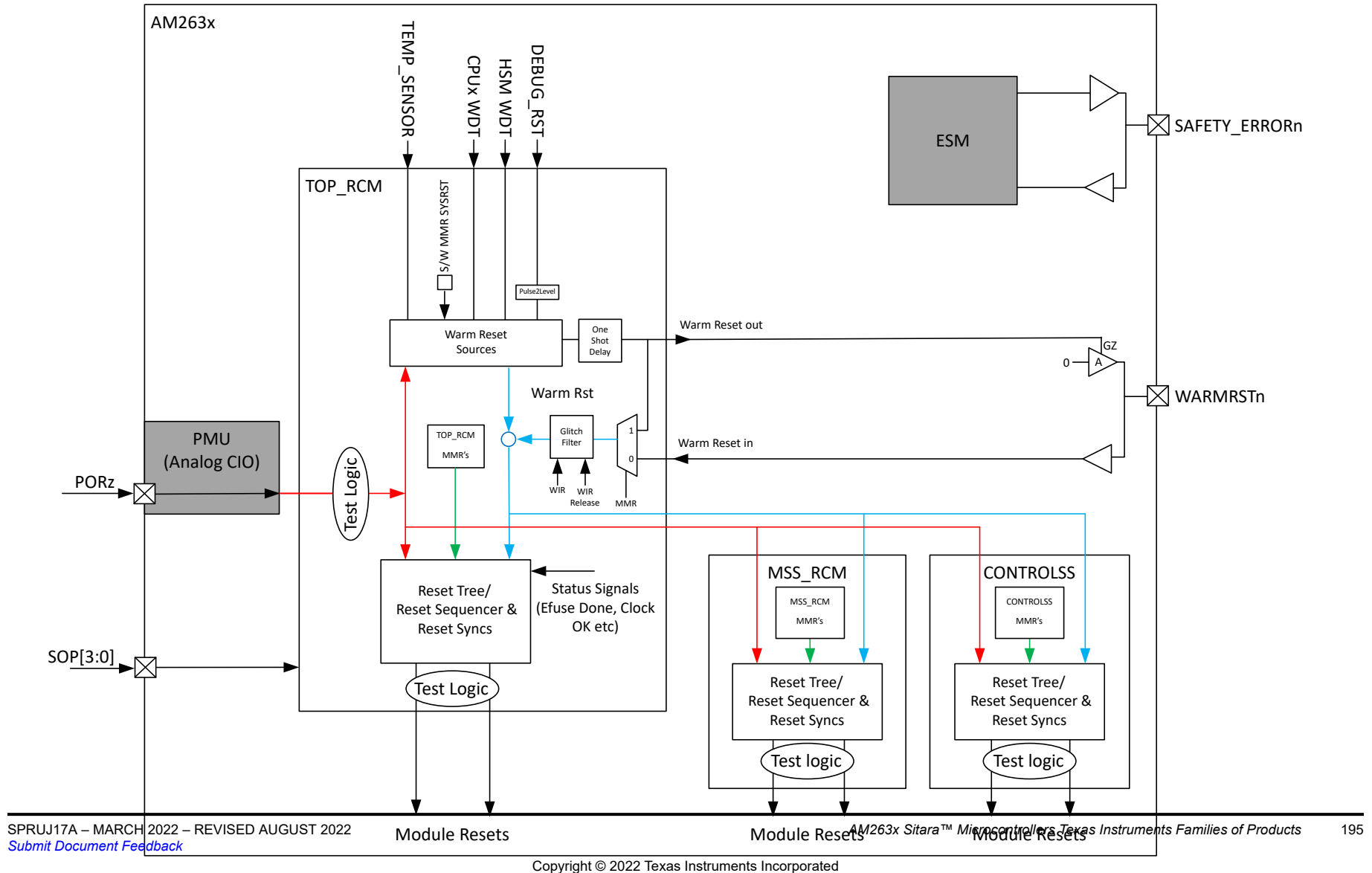

ADVANCE INFORMATION

Figure 6-14. AM263x Reset Architecture Block Diagram

6.3.2 Reset Sources

This table summarizes the available reset sources that are supported by the device.

Table 6-16. Device Reset Sources

Reset Name	Reset Type	Sync/ Async	Pin/Register/ Internal	Details
PORz	Hardware POR	Async	PORz HW Pin	PORz Reset
WARMRSTn	Hardware Warm Reset	Async	WARMRSTn HW Pin	WARMRSTn
SW_WARMRSTn	Software Warm Reset	Async	TOP_RCM.WARM_RESET_REQ	SW_WARMRSTn
WDT Reset	WDT reset	Async	Internal signal	WDT Resets
Debugger Reset	Debugger Reset	Async	Internal signal	Debugger Reset

6.3.3 Reset Status

This section explains the Reset Status functionality. An output pin or software bit is used to represent the status of a specific individual reset.

Table 6-17. Reset Status Table

Reset Status Name	Reset Status Source	Reset Status Info	Signal Active Level	Reset Signal Details
TOP_RCM.WARM_RST_CAUSE Status Register	Register	Status register capturing which event caused the warm reset	Status bits read active HIGH (1) when a particular reset is asserted.	WARM_RST_CAUSE
MSS_RCM.R5SSx_RST_STATUS	Register	Status register capturing which event caused the corresponding R5SS reset	Status bits read active HIGH (1) when a particular reset is asserted.	R5SSx_RST_STATU S
WARMRSTn	Output Pin	On/Off pin status of warm reset	Active LOW (0)	WARMRSTn

6.3.3.1 Reset Source Status Registers

All reset sources which trigger a device/domain warm reset are captured in the TOP_RCM.WARM_RST_CAUSE reset status register. This register is only reset on PORz.

After recovery from warm reset, software can read this reset source register to identify the source of previous reset. After reading this reset source register, software must clear the register. TOP_RCM.WARM_RST_CAUSE_CLR needs to be written with 3'b111 to clear the status bits.

Reset status bits read active HIGH (1) when a particular reset is triggered.

The following reset sources, which cause system resets, are captured in the reset source register:

- PORz (Reset by PORz Hardware Pin)
- WARMRSTn (Reset by WARMRSTn Hardware Pin)
- SW_WARMRSTn (Reset by TOP_RCM:WARM_RESET_REQ)
- MSS_WDT0 (Reset by MSS_WDT0)
- MSS_WDT1 (Reset by MSS_WDT1)
- MSS_WDT2 (Reset by MSS_WDT2)
- MSS_WDT3 (Reset by MSS_WDT3)
- HSM_WDT (Reset by HSM_WDT)
- Debugger reset (Reset by SYSRESET from debugger)
- Thermal alert0 (Reset by comparator 0 of tempensor)
- Thermal alert1 (Reset by comparator 1 of tempensor)

Additionally individual R5SS have there own status register MSS_RCM.R5SS0_RST_STATUS & MSS_RCM.R5SS1_RST_STATUS to capture the source of R5SS internal resets. After reading

this reset source register, software must clear the register. MSS_RCM.R5SS0_RST_CAUSE_CLR/ MSS_RCM.R5SS1_RST_CAUSE_CLR needs to be written with 3'b111 to clear the status bits.

Reset status bits read active HIGH (1) when a particular reset is triggered.

The following are the status bit sources

- POR Reset
- Warm Reset (Also set during POR Reset)
- R5SSx STC Reset
- Reset for CORE0 and CORE0_VIM using MSS_RCM::R5SSx_CORE0_GRST_CTRL
- Reset for CORE1 and CORE1_VIM using MSS_RCM::R5SSx_CORE1_GRST_CTRL
- Reset for CORE0 only using MSS_RCM::R5SSx_CORE0_LRST_CTRL
- Reset for CORE1 only using MSS_RCM::R5SSx_CORE1_LRST_CTRL
- Reset for CORE0 and CORE0_VIM caused because of reset request by debugger in CORE0
- Reset for CORE1 and CORE1_VIM caused because of reset request by debugger in CORE1
- Reset for R5SSx by the RESET FSM using MSS_CTRL::R5SSx_CONTROL_RESET_FSM_TRIGGER
- Reset for R5SSx using MSS_RCM.R5SSx_POR_RST_CTRL0

Note

R5SSx refers to R5SS0 and R5SS1.

6.3.3.2 WARMRSTn Status Pin

This pin indicates warm reset status (active LOW) of the system.

When LOW, it indicates that the system is in a warm reset state.

When HIGH, it indicates that the system is out of reset.

The status of this signal will be captured in TOP_RCM.WARM_RST_CAUSE.

6.3.4 Reset Controls

The reset control registers enable, disable, and adjust specific reset operations. This section explains how to control certain device resets.

6.3.4.1 Reset Control Registers

These are the TOP_RCM and MSS_RCM registers that are able to enable and disable reset abilities and options.

Table 6-18. Reset Control Registers

Control Register	Control Action
TOP_RCM.WARM_RESET_CONFIG	Enable/disable individual warm reset sources
TOP_RCM.WARM_RESET_REQ	SW warm reset request
TOP_RCM.WARM_RST_CAUSE_CLR	Clear request for registered warm reset cause
TOP_RCM.WARM_RSTTIME1	Control to program output delay on warm reset Pad
TOP_RCM.WARM_RSTTIME2	Control to program input rise delay of warm reset Pad
TOP_RCM.WARM_RSTTIME3	Control to program input fall delay of warm reset Pad
MSS_RCM.R5SSx_DBG_RST_EN	Controls enable/disable of debug reset request to reset CORE0 and CORE1
MSS_RCM.R5SSx_RST_ASSERTDLY	Controls the number of cycles reset should be kept asserted for R5SS resets.
MSS_RCM.R5SSx_RST2ASSERTDLY	Controls the number of cycles reset should be to wait before asserting R5SS resets.
MSS_RCM.R5SSx_RST_WFICHECK	Enable/disables if WFI is required before asserting R5SS resets.
MSS_RCM.<IP>_RST_CTRL	Controls the individual IP reset generation

Note

For more information, see TOP_RCM and MSS_RCM
 R5SSx refers to individual R5SS0 and R5SS1
 <IP> refers to different IPs in the design.

The table refers to the programmable values for WARM_RSTTIME1/2/3 vs the corresponding delays in design

Programmable value	Delay Value
0	500 ns
1	1us
2	2us
3	4us
4	8us
5	16us
6	32us
7	64us
8	128us
9	256us
10	512us
11	1.024ms
12	2.048ms

13	4.096ms
14	8.192ms
15	16.384ms

6.3.5 Reset Details

Reset Details Introduction

The Reset Details section will break down the available device resets and explain operating details such as sequencing and reset logic diagrams. It also includes any additional information related to the device resets.

6.3.5.1 POR Resets

6.3.5.1.1 PORz Reset

Reset Overview

This is the master POR input (active LOW) to the entire device.

When LOW, it performs a POR reset on the entire device and puts all IOs in a safe state (Reset/HHV state).

Upon PORz desassertion, IOs will enter the default state defined in the Device Datasheet and the boot process will be initiated.

PORz timing sequence below shows the reset sequence during PORz assertion and related timing for WARMRSTn pad and the internal reset.

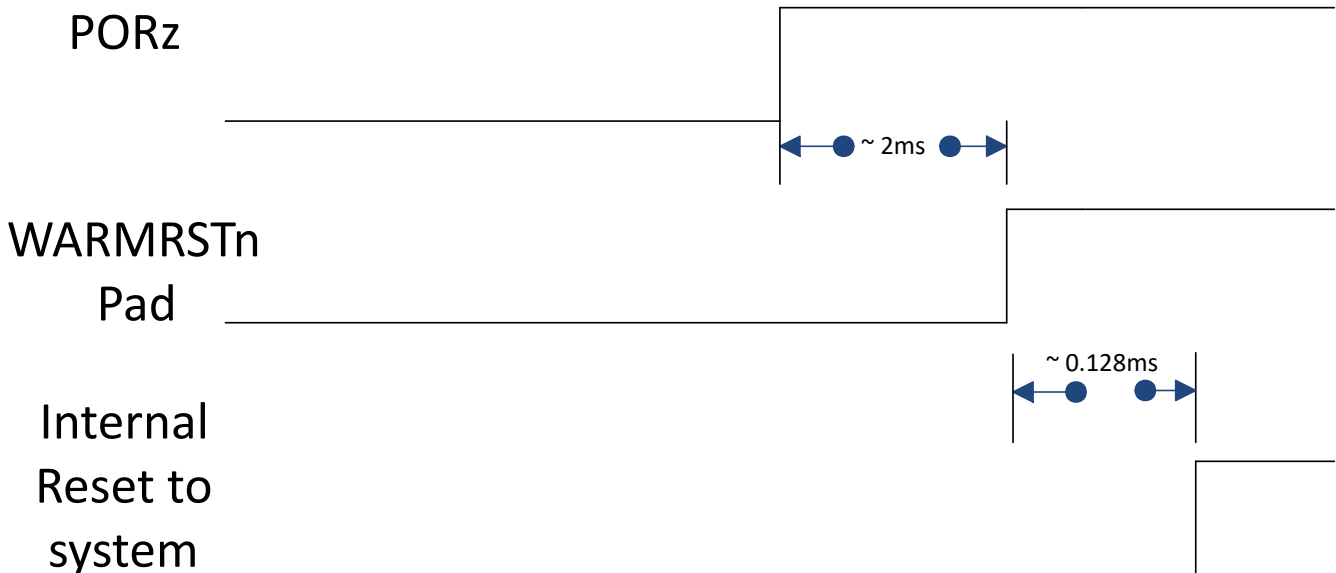

Figure 6-15. PORz timing sequence

Note

SOP pin pull ups/pull downs to configure the boot mode should be held steady during the PORz assertion.

6.3.5.2 Warm Resets

6.3.5.2.1 WARMRSTn Reset

Reset Overview

This reset pin is the external warm reset request (active LOW). By default the input path to trigger a warm reset from external pad is disabled. To enable, the TOP_RCM:WARM_RESET_CONFIG:PAD_BYPASS bit should be written with '3b000.

When LOW is detected, reset hardware generates an internal warm reset to most of the logic. (Except for logic running on PORz)

All IO configurations are reset during warm reset assertion.

Reason for this reset is captured in TOP_RCM.WARM_RST_CAUSE reset source register. After reset is deasserted, device will boot-up and software can read the register to check the reset source.

TOP_RCM.WARM_RST_CAUSE_CLR should be written with 3'b111 to clear the status bits. A PORz assertion also clears status register.

The timing diagram shows the reset sequence during WARMRSTn pad assertion and related timing for the internal reset.

The glitch filter logic will filter any input pad signal which is LOW for any time less than TOP_RCM.WARM_RSTTIME3 as shown in the sequence below. Similarly, the signal should remain HIGH for TOP_RCM.WARM_RSTTIME2 continuously to register a deassertion of WARMRSTn. The internal reset gets asserted at time TOP_RCM.WARM_RSTTIME3 relative to external WARMRSTn pad being asserted LOW.

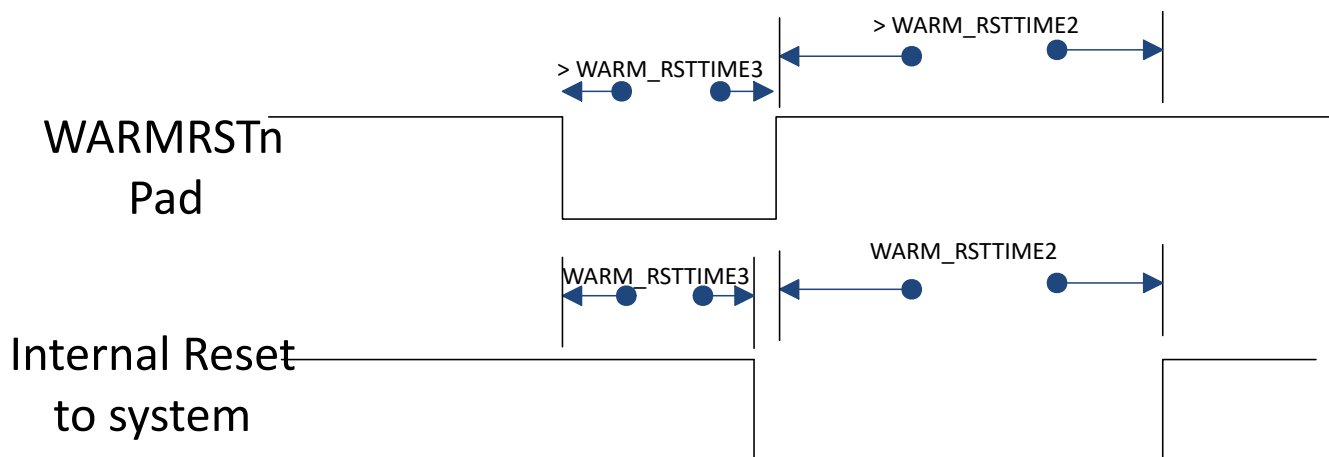

Figure 6-16. WARMRSTn Pad reset sequence

6.3.5.2.2 Internal Warm Reset Sources

The different internal reset sources are :-

- SW_WARMRSTn
- Watchdog time-out resets (4x/SoC + 1x/HSM)
- Debugger SYSRST request

All of the warm reset sources have a corresponding enable bit in register TOP_RCM:WARM_RESET_CONFIG to control if the sources trigger a warm reset.

The timing sequence shows the overall sequence between assertion of internal reset sources relative to internal system reset and WARMRSTn pad.

The assertion of internal reset and the external WARMRSTn pad happens together with assertion of any of the internal reset sources. The external WARMRSTn pad deassertion is controlled by

TOP_RCM.WARM_RSTTIME1 to enable sufficient time for any external device relying on the reset signal. The internal system reset deassertion is relative to the deassertion of WARMRSTn pad and can be controlled by TOP_RCM.WARM_RSTTIME2

All IO configuration get reset due to warm reset assertion.

Reason for this reset is captured in TOP_RCM.WARM_RST_CAUSE reset source register. After reset is deasserted, device boots up and can read the status to check on the source of reset.

TOP_RCM.WARM_RST_CAUSE_CLR needs to be written with 3'b111 to clear the status bits. A PORz assertion also clears status register.

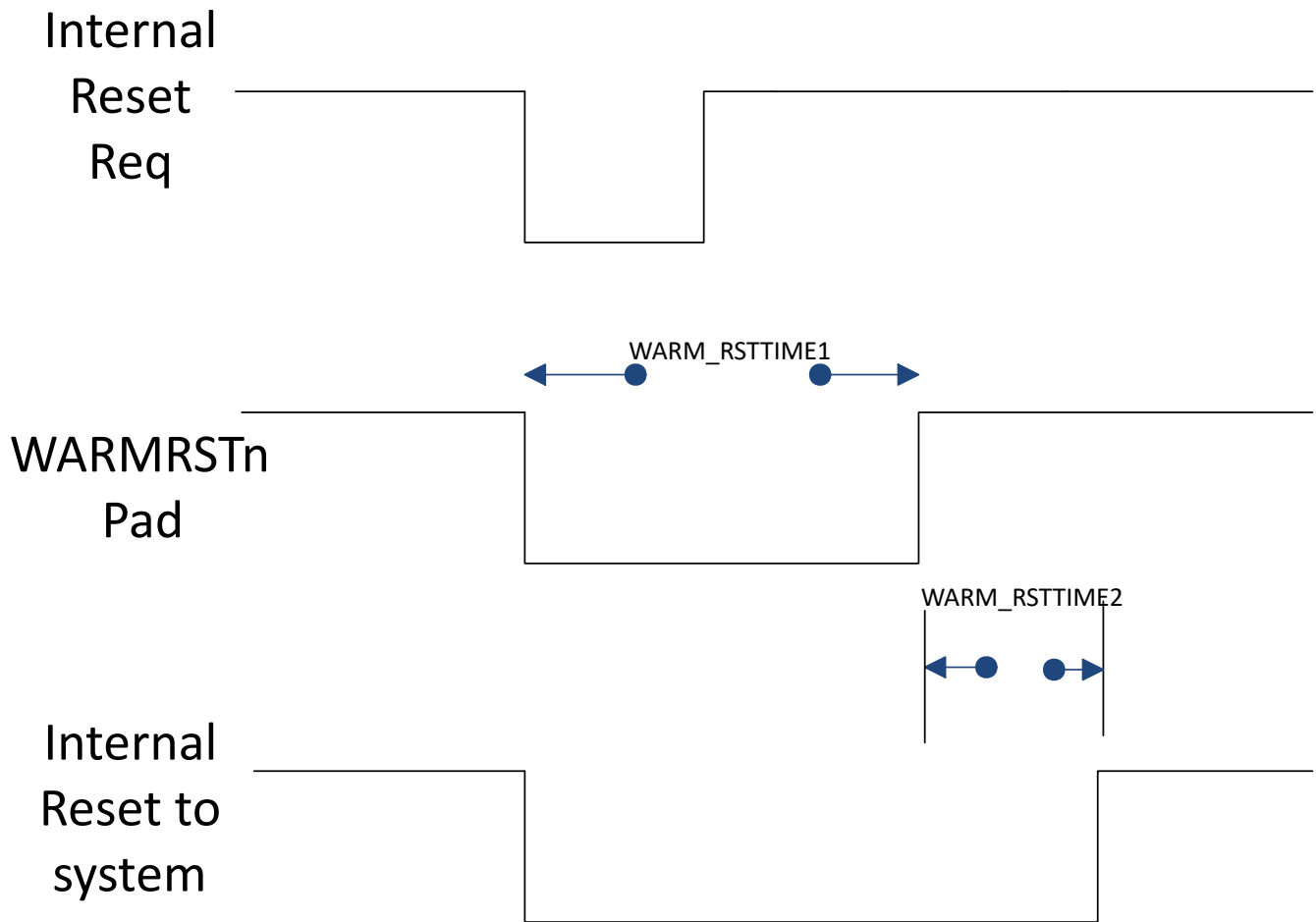

Figure 6-17. Internal reset sequence

6.3.5.2.2.1 SW_WARM_RESET

Reset Overview

This reset is a software controlled warm reset register defined in TOP_RCM.WARM_RESET_REQ. The reset behaves in the same manner as other warm reset sources.

Any processor which needs to issue a warm reset to the system, should write 3'b000 into the TOP_RCM.WARM_RESET_REQ register.

6.3.5.2.2.2 WDT Resets

Reset Overview

This reset is issued when a WDT timeout event occurs. There are 4 WDT available at SOC which can be allocated to individual R5SS cores. Additional HSM has its own dedicated WDT.

6.3.5.2.2.3 Debugger Reset

Reset Overview

The debugger also can issue a warmreset by initiating a SYSRESET request.

6.3.5.3 Local Module Resets

The MSS_RCM.<IP>_RST_CTRL MMR's in the MSS_RCM module can be used by S/w to affect reset of individual modules. This feature is for debug purpose only. Software needs to ensure the state of the Device/IP before configuring.

6.3.5.4 R5FSS Reset

Transitions from Lockstep to Dual Core or vice-versa requires a POR reset of the R5FSS.

Additionally, POR reset of R5FSS is needed for enforcing ROM eclipse.

Thr R5FSS POR reset triggered by writing to MSS_CTRL (Reset_FSM_TRIGGER).

R5F WFI check is enabled by MSS_RCM.R5SSx_RST_WFICHECK, the FSM checks the WFI status of CPU to be entered before propagating the reset.

Delays for asserting the reset and holding the reset can be programmed in the MSS_RCM.R5SSx_RST_ASSERTDLY and MSS_RCM.R5SSx_RST2ASSERTDLY registers.

Triggering STC also results in a POR reset of the R5FSS.

6.3.5.5 Reset - High Heating Value (HHV)

IOs support HHV mode during power up. HHV is defined as a state when PORz signal is driven LOW.

HHV is an IO Voltage Buffer feature that allows the IO cells to be tri-stated. All IO cells have HHV which is asserted (driven) by HHV generated during PORz assertion. There are default pull values during this HHV/PORz assertion specified in the device-specific Datasheet for each pin. All HHV logic controlling the buffer high-impedance control and the associated default pull value will be asynchronous.

6.4 Clocking

This chapter describes the clock architecture of the device.

Note

For a detailed visual representation of the distribution and management of the device clocks at the device level, see the clock interactive software for the device - Clock Tree Tool (CTT) (**CTT is under development**).

6.4.1 Overview.....	204
6.4.2 Clock IO.....	213
6.4.3 IP Clocking.....	215
6.4.4 Limp Mode.....	237
6.4.5 Clocking Registers.....	238

6.4.1 Overview

To satisfy the various subsystems requirements, the device features multiple clock sources and clock generators:

- External Crystal Driver
- Internal Oscillator
- Phase-Locked Loop circuits (PLLs)
- Dividers

Figure 6-18 shows a high-level overview of the device clock architecture. The figure captures the key clock sources and the configuration options available to select the appropriate clock source. The detailed structure is captured under each PLL clocking section.

ADVANCE INFORMATION

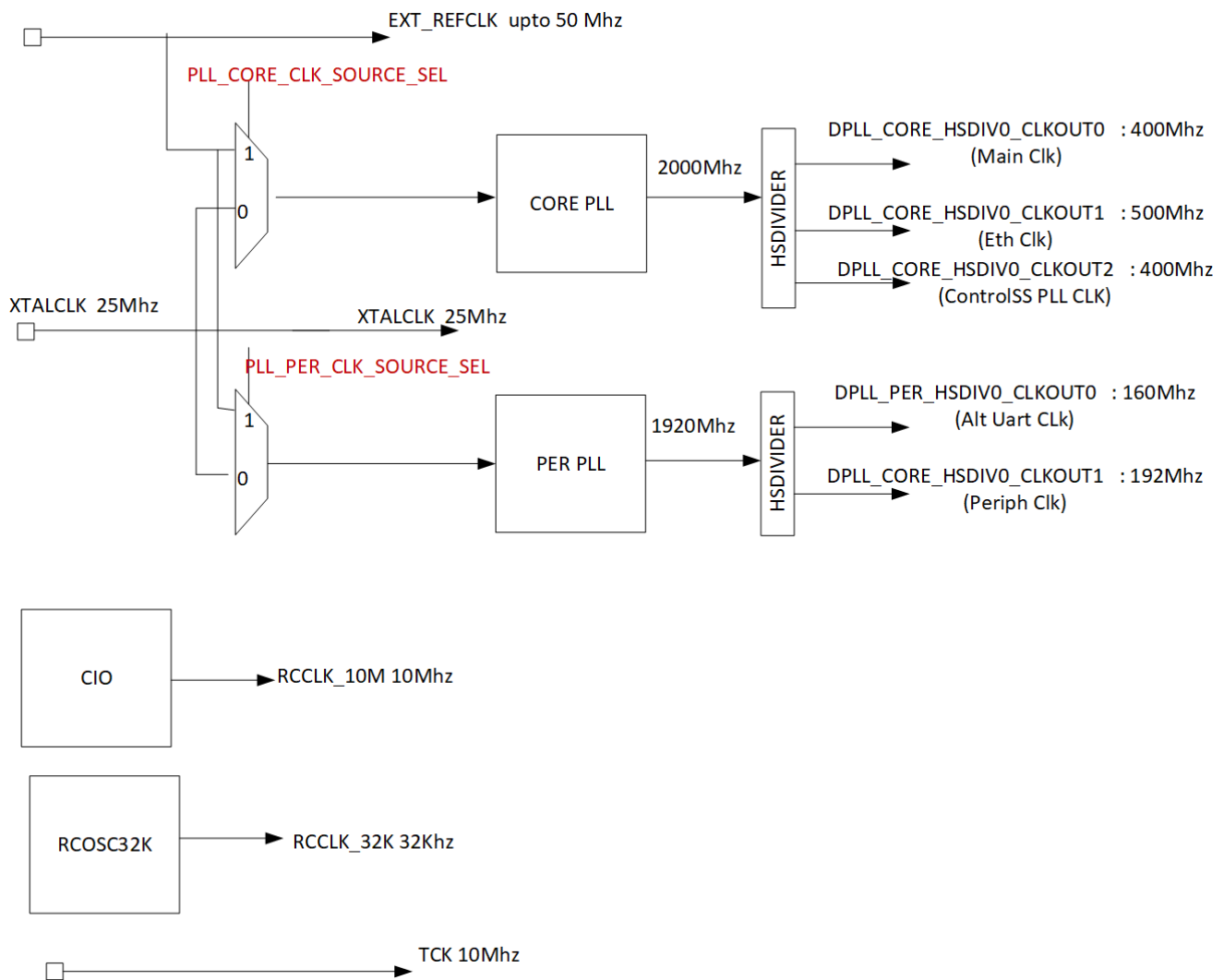

Figure 6-18. Root Clocks

The overall clock tree structure is as depicted in Figure 6-19.

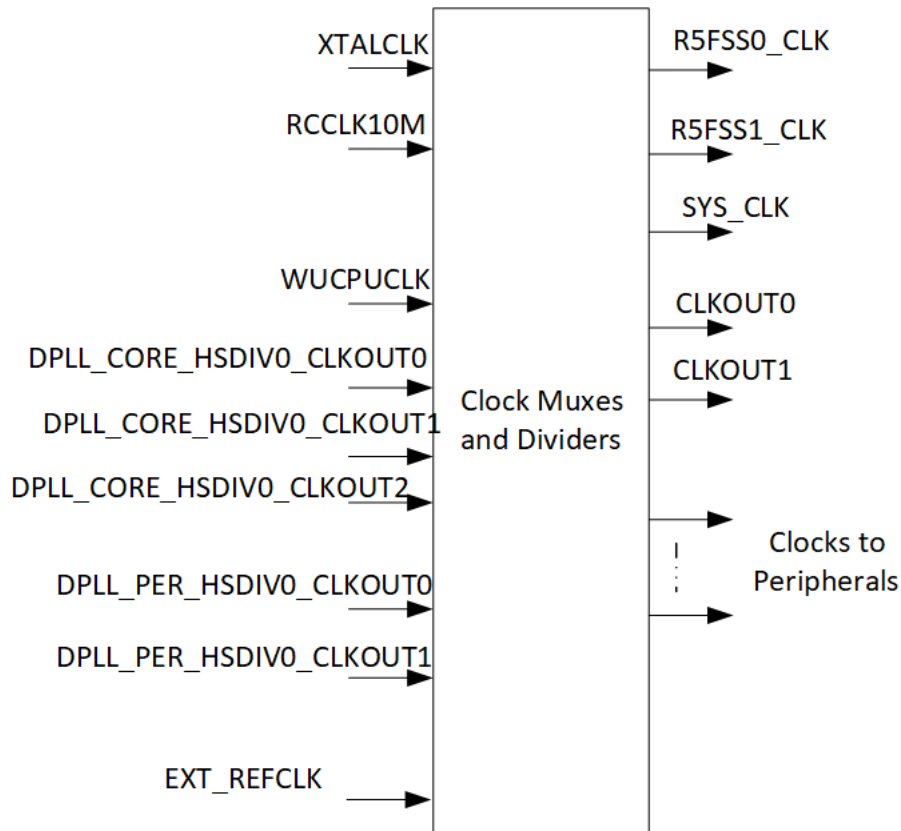

Figure 6-19. Core Clock Tree

6.4.1.1 PLL Overview

Phase-Locked Loop circuits (PLLs) in the device are clock generator PLLs, which multiply the lower-frequency reference clock up to the operating frequency of the respective subsystem(s).

6.4.1.1.1 PLL Hookup

Bypass of PLL and HSDIVIDER will be by XTALCLK

PLL will be set to BUSSEL2-0 = 010 (Direct mode) . PLL input pins are driven by TOP_RCM MMR's and the outputs are mapped as status on the TOP_RCM MMR.

The Phase_lock signal of CORE and PER PLL are inverted and connected as corresponding clock_loss signal in ESM.

6.4.1.1.2 CORE PLL Overview

CORE_PLL is primarily responsible for the following IPs:

Description	Key Frequencies (MHz)
R5 Clock	400
Interconnect	200
Ethernet	250/50/5
QSPI, CANFD	80
HSM Clock	200
SPI Clock	40

Description	Key Frequencies (MHz)
GPMC Clock	100
FSI/SDFM PLL Clock	400

6.4.1.1.3 PER PLL Overview

PER_PLL is primarily responsible for the following IPs:

Description	Key Frequencies (MHz)
UART Clock	192
MMC Clock	50
SPI Clocks	50
I2C Clocks	48

6.4.1.2 Analog Modules

6.4.1.2.1 ADPLLJ Module

The low-jitter ADPLLJ module is used as the Device CORE and PER PLL's. It is similar to the ADPLL but does not provide CLKOUTx2 and CLKOUTHIF outputs. A high level block diagram of the ADPLLJ is shown in [ADPLLJ Architecture](#).

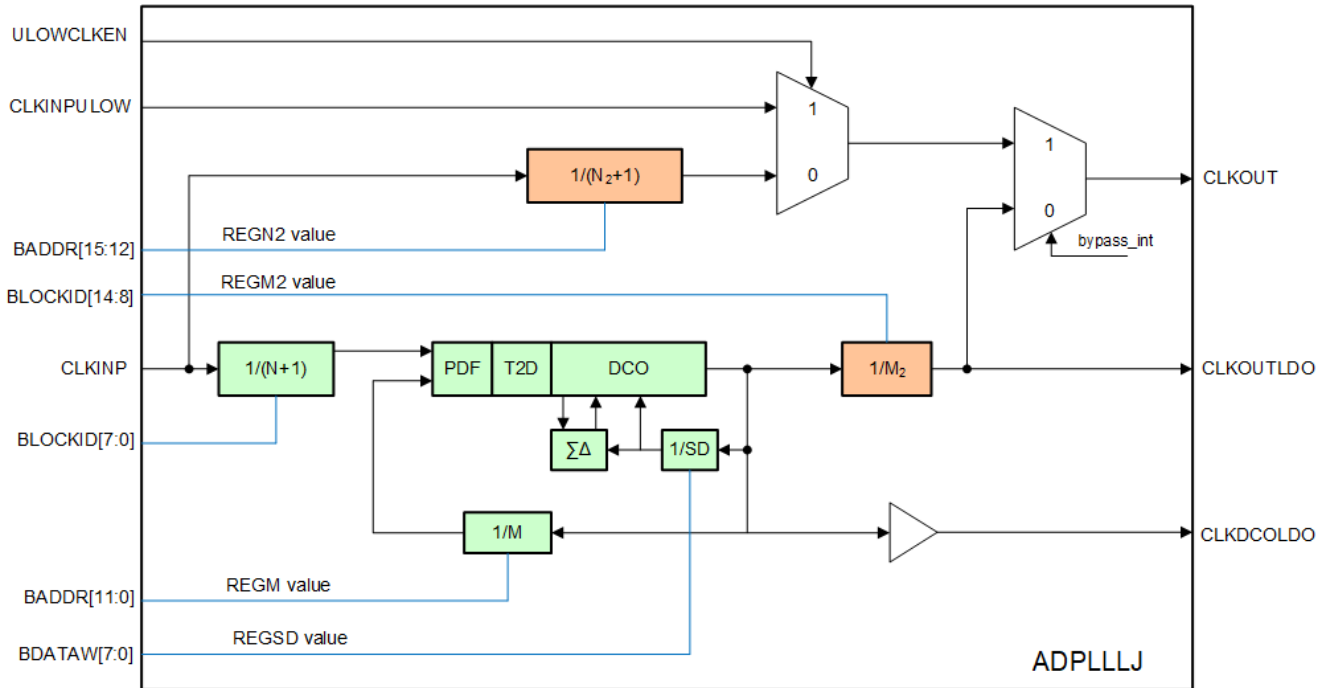

Figure 6-20. ADPLLJ Architecture

Note

The only output clock applicable to this device is CLKOUTLDO. CLKDCOLDO and CLKOUT are not used

The ADPLLJ can be programmed to be locked at any frequency given by the following equation:

$$f_{DPLL} = \frac{M * CLKINP}{N + 1}$$

Where:

- f_{DPLL} is the lock frequency.
- CLKINP is the reference system clock.
- M is the 12-bit “multiplication ratio” binary value (2 – 4095). In Device it is S/W programmable via a dedicated PRCM register.
- N is the 8-bit “division ratio” binary value (0 – 255). In Device it is S/W programmable via a dedicated PRCM register.

The ADPLLJ has two input clocks:

- CLKINP is the mandatory reference clock used to generate the synthesized clock. It can also be used to generate the bypass clock whenever the ADPLLJ enters a bypass mode.

- CLKINPULOW is an optional low-frequency clock input and is used when selected as the bypass clock.

The ADPLLLJ has three output clocks:

- CLKDCOLDO is the output of the PLL.
- CLKOUT is the primary output clock generated from the lock frequency of the PLL and post divider. It runs at the selected bypass clock frequency when the ADPLLLJ is in bypass mode.
- CLKOUTLDO is the secondary output clock generated from the lock frequency of the PLL and post dividers. It does not have a bypass mode.
- The ADPLLLJ output clock frequency values are summarized in Table 8-2 below where:
- f_{DPLL} is the lock frequency.
- M2 is the 7-bit post divider binary value (1 – 127). In Device is S/W programmable via a dedicated PRCM register.

Table 6-19. ADPLLLJ Output Clocks

Clock Names	Frequency	Bypass Mode Frequency
CLKDCOLDO	f_{DPLL}	none
CLKOUT	f_{DPLL}/M_2	CLKINPULOW or CLKINP/N ₂
CLKOUTLDO	f_{DPLL}/M_2	none

Note

Bypass Modes are not supported in ADPLLLJ since the design does not implement external bypass mux or use the CLKOUT as the output of the PLL

6.4.1.2.2 HSDIVIDER Module

The ADPLLLJ can be coupled with an HSDIVIDER module to generate additional clocks which are divided down from the PLL lock frequency.

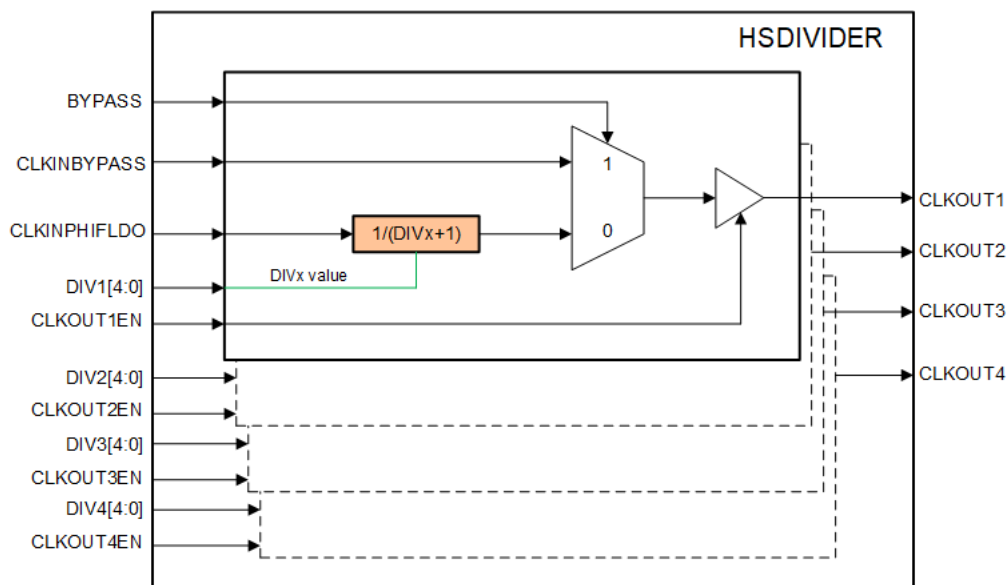

Figure 6-21. HSDIVIDER Architecture

The HSDIVIDER provides 4 post divider clocks whose frequency is given by:

$$CLKOUT_x = \frac{CLKINPHIFLDO}{DIV_x + 1}$$

Where:

- CLKINPHIFLDO is the input clock frequency.
- DIVx is the 5-bit divisor binary value (0-31). On Device it DIVx values are software programmable via dedicated PRCM registers. Note: PRCM provides registers to directly configure the final divide value of “DIVx+1”. This is done by subtracting one from register value and feeding HSDIVIDER with DIVx. The DIVx+1 reset value is 4.

The CLKOUT1 to CLKOUT4 outputs are also called the M4-M7 outputs in the Device design. They are independent of the M2 and M3 divider settings located within the ADPLLS.

The HSDIVIDER has two input clocks:

- CLKINPHIFLDO is the mandatory reference clock used to generate the divided clock outputs.
- CLKINBYPASS is an optional clock input and is used when selected as the bypass clock.

6.4.1.2.3 PLL and Root Clocks Programming Guide

6.4.1.2.3.1 PLL Configurations

Note

This section describes the sequence in order to configure both the CORE_PLL and PER_PLL. For information on PLL configuration during boot, please refer to [Chapter 4 - Initialization](#)

6.4.1.2.3.1.1 Kick Protection Mechanism

Before accessing any register in MSS_RCM and TOP_RCM memory map, unlock the corresponding LOCK_KICK config registers with the following values:

1. LOCK0_KICK0.LOCK0_KICK0 = 0x01234567
2. LOCK0_KICK1.LOCK0_KICK1 = 0x0FEDCBA8

The above unlock procedure should be repeated for CONTROLSS_CTRL before configuring any MMRs in that region.

After these two steps a write access to the PLL registers is allowed. Writing any other data value to either of these two registers locks the kicker mechanism and blocks any writes to the PLL registers.

Note

In order to ensure that all PLL registers are write protected, software must always re-lock the kicker mechanism after completing the register writes.

6.4.1.2.3.1.2 Sequence to Configure the CORE PLL

1. Check for the CRYSTAL present status from CLK_LOSS_STATUS.CRYSTAL_CLOCK_LOSS register in TOP_RCM before proceeding further in configuring the PLL (Note - Optional if ROM implements)
2. If the CRYSTAL is not present then abort the PLL lock procedure and continue with RC_CLK for boot (Note - Optional if ROM implements)
3. Program the N divider of the PLL with the calculated value of 0x9 in register field in order to get REF_CLK suitable for PLL locking, PLL_CORE_M2NDIV.N = 0x09
4. Program the M2 divider with the value of 0x1 in the register field to get the desired frequency after PLL locking, PLL_CORE_M2NDIV.M2 = 0x1
5. Update the M divider setting of the PLL with the value which is derived from the above formula, PLL_CORE_MN2DIV.M = 0x360
6. Program the N2 divider of the PLL with the value of 0x0 to get the BYPASS clock same as CLKINP frequency, PLL_CORE_MN2DIV.N2 = 0x0
7. Program the SD divider of the PLL with the value of 0x8 to get the optimum jitter performance, PLL_CORE_FRACDIV.REGSD = 0x8

8. Clear the IDLE bit from PLL_CORE_CLKCTRL register to make the *PLL* active for locking,
PLL_CORE_CLKCTRL.IDLE= 0x0
9. Assert the TENABLE signal to make the M, N, SD divider and SEL_FREQ settings to get loaded into the *PLL* for locking, PLL_CORE_TENABLE.TENABLE = 0x1
10. Assert the TINTZ signal of the *PLL* to make the *PLL* out of SOFT reset, PLL_CORE_CLKCTRL.TINTZ = 0x1
11. De-assert the TENABLE signal by clearing the register with the value of 0x0,
PLL_CORE_TENABLE.TENABLE = 0x0
12. Assert and de-assert the TENABLEDIV signal of the *PLL* by setting and clearing its corresponding register field,

PLL_CORE_TENABLEDIV.TENABLEDIV = 0x1

PLL_CORE_TENABLEDIV.TENABLEDIV = 0x0
13. Wait for the *PLL* to lock by polling the PHASELOCK bit to go high in the status register,
PLL_CORE_STATUS.PHASELOCK = 0x1
14. Program the divider settings of the various PLL CORE HSDIVDER CLKOUT in their corresponding register field depending on the required output frequency,

PLL_CORE_HSDIVIDER_CLKOUT0.DIV = 0x04 (i.e. 400 MHz)

PLL_CORE_HSDIVIDER_CLKOUT1.DIV = 0x03 (i.e. 500 MHz)

PLL_CORE_HSDIVIDER_CLKOUT2.DIV = 0x04 (i.e. 400 MHz)
15. Assert and de-assert the TENABLEDIV signal of the PLL CORE HSDIVER by setting and clearing the corresponding register field,

PLL_CORE_HSDIVIDER.TENABLEDIV = 0x1

PLL_CORE_HSDIVIDER.TENABLEDIV = 0x0
16. Un-gate the clocks from all CLKOUT of PLL CORE HSDIVDER with the following configuration,

PLL_CORE_HSDIVIDER_CLKOUT0.GATE_CTRL = 0x1

PLL_CORE_HSDIVIDER_CLKOUT1.GATE_CTRL = 0x1

PLL_CORE_HSDIVIDER_CLKOUT2.GATE_CTRL = 0x1

Note

Note that PLL_CORE_HSDIVIDER.TENABLEDIV and PLL_CORE_TENABLE.TENABLE reference TENABLE fields in different registers. Make sure to address the correct registers when loading the M, N, SD dividers and SEL_FREQ settings and also when loading the HSDIVIDER values.

6.4.1.2.3.1.3 Sequence to Configure the PER PLL

The configuration sequence used for locking the CORE *PLL* (point 3 to 12) to be followed along with calculated values which is dependent on PER *PLL* lock frequency is programmed in the registers available for PER *PLL* inside TOP_RCM memory map for locking the PERIPHERAL *PLL*.

For PLL PER HSDIVDER settings follow the sequence below,

1. Program the divider settings of the various PLL PER HSDIVDER CLKOUT in their corresponding register field depending on the required output frequency,

PLL_PER_HSDIVIDER_CLKOUT0.DIV= 0x0B (i.e. 160 MHz)

PLL_PER_HSDIVIDER_CLKOUT1.DIV = 0x09 (i.e. 192 MHz)
2. Assert and de-assert the TENABLEDIV signal of the PLL PER HSDIVER by setting and clearing the PLL_PER_HSDIVIDER.TENABLEDIV register field,

PLL_PER_HSDIVIDER.TENABLEDIV = 0x1

PLL_PER_HSDIVIDER.TENABLEDIV = 0x0

- Un-gate the clocks from all CLKOUT of PLL PER HSDIVDER with the following configuration,

PLL_PER_HSDIVIDER_CLKOUT0.GATE_CTRL = 0x1

PLL_PER_HSDIVIDER_CLKOUT1.GATE_CTRL = 0x1

Note

- For faster PLL locking, configure the PLL settings (point 3 to 11) of both PLL's before polling for the lock of the corresponding PLL
 - For PLL lock using *EXT_REF* clock, configure the PLL_REF_CLK_SRC_SEL.PLL_CORE_REF_CLK_SRC_SEL (or) PLL_REF_CLK_SRC_SEL.PLL_PER_REF_CLK_SRC_SEL register fields in TOP_RCM before starting the PLL configurations
 - Configure the *DCC* with reference clock as CRYSTAL and compare clock as *PLL_CORE_CLKOUT1* to measure the frequency range before switching the *SYS_CLK / R5* CLK to PLL clock. Refer *DCC* chapter for more information in its configuration and usage (Note - Optional configuration only used for safety purpose)
-

6.4.1.2.3.1.4 Sequence to Re-Configure the PLL

The following section provides details of steps involved in re-configuring the PLL with new frequency,

- Switch all the peripheral clocks which are derived from PLL to WUCPU_CLK (XTAL_CLK) so that when PLL is unlocked other peripheral are in safe state. (Refer IP Clock configuration section for programming)
- Change the CPU clock source to WUCPU_CLK (XTAL_CLK) by programming the R5SS GCM with the value of 0x0 and SYS_CLK GCD (optional) with the value of 0x0 so that CPU does not enter into dead lock condition. (Refer Root clock configuration section for programming)
- Assert the TINTZ signal of the PLL to reset the internal FSM of PLL, PLL_CORE_CLKCTRL.TINTZ = 0x0
- Follow the steps mentioned in the PLL CORE configuration sequence from point 3 to 12 to re-configure the PLL CORE

Note

Follow the above-mentioned steps except point (2) to re-configure the PLL PER

6.4.1.2.3.2 Root Clock Configurations

6.4.1.2.3.2.1 Sequence for Programming SYS and R5 Clocks

- Program SYS CLK GCD register with the value of 0x111 in-order to switch to a new desired frequency, SYS_CLK_DIV_VAL.CLKDIV = 0x111
- Poll for the CURRDIVR field of corresponding status register to reflect its new frequency change, SYS_CLK_STATUS.CURRDIVIDER = 0x1
- If the R5 clock frequency needs to be same as SYS clock frequency, then program the R5SS0_CLK_DIV_SEL.CLKDIVSEL = 0x7 (or / and) R5SS1_CLK_DIV_SEL.CLKDIVSEL = 0x7 register(s) as required or else leave with default value of 0x0 without any programming
- After the divider configuration, update the R5SS GCM register with the value of 0x222 to select the PLL_CORE_CLOCKOUT0 as its source, R5SS_CLK_SRC_SEL.CLKSRCSEL = 0x222
- Poll for the CLKINUSE field of corresponding status register to reflect its new frequency change, R5SS_CLK_STATUS.CLKINUSE = 0x04

6.4.1.2.3.2.2 Sequence for Programming TRACE Clock

- Program TRCCLKOUT GCD register with the value of 0x111 in-order to switch to a new desired frequency, TRCCLKOUT_DIV_VAL.CLKDIV = 0x111
- Poll for the CURRDIVR field of corresponding status register to reflect its new frequency change, TRCCLKOUT_CLK_STATUS.CURRDIVIDER = 0x01
- Update the TRCCLKOUT GCM register with the value of 0x222 to select *PLL_CORE_CLKOUT1* as its source, TRCCLKOUT_CLK_SRC_SEL.CLKSRCSEL = 0x222

4. Poll for the CLKINUSE field of corresponding status register to reflect its new frequency change, TRCCLKOUT_CLK_STATUS.CLKINUSE = 0x04

6.4.1.2.3.2.3 Sequence for Programming CLKOUT Clock

1. Program CLKOUT0 GCD register with the value of 0x000 in-order to switch to a new desired frequency, CLKOUT0_DIV_VAL.CLKDIV = 0x111
2. Poll for the CURRDIVR field of corresponding status register to reflect its new frequency change, CLKOUT0_CLK_STATUS.CURRDIVIDER = 0x01
3. Update the CLKOUT0 GCM register with the value of 0x222 to select *PLL_CORE_CLKOUT1* as its source, CLKOUT0_CLK_SRC_SEL.CLKSRCSEL = 0x222
4. Poll for the CLKINUSE field of corresponding status register to reflect its new frequency change, CLKOUT0_CLK_STATUS.CLKINUSE = 0x04

6.4.2 Clock IO

6.4.2.1 Overview

Various external clock inputs are needed to drive the device, as well as there are external sources of the clock provisioned for certain peripherals. The clocks in the AM263x device are as depicted in Figure [External Clocks](#)

The device provides several system clock outputs. Summary of these output clock signals is as follows:

- R5FSS[1:0]_CLK
- SYS_CLK
- CLKOUT[1:0]
- IP Clocks

The IP Clocks are routed directly from subsystems to device pins, and they are described in the respective module chapter.

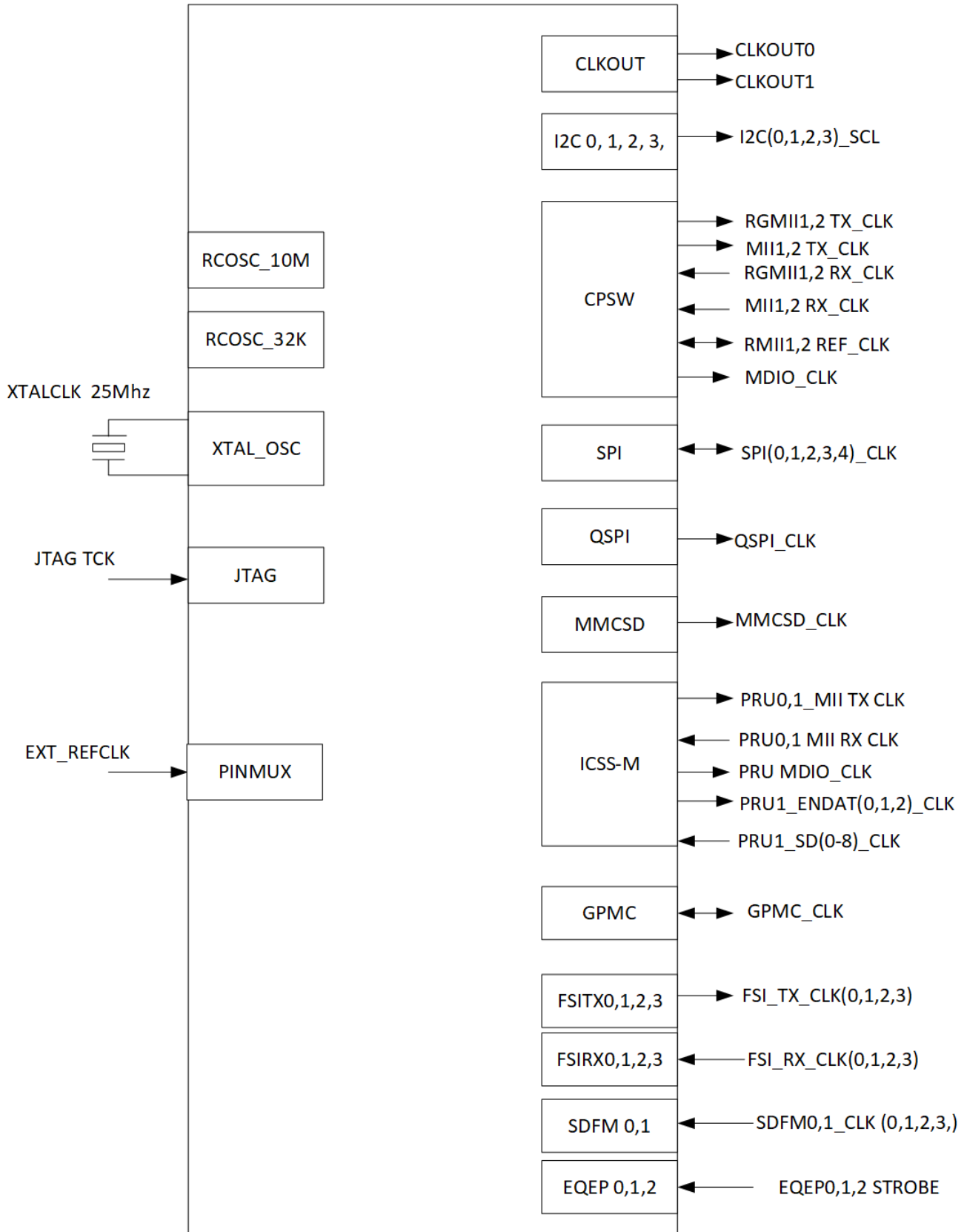

Figure 6-22. External Clocks

Note

While this device does not support a separate Observation Clock output signal, the system level functionality is recognized by utilizing the CLKOUT[1:0] signals

Note

CLKOUT0 will reflect RC clock after POK is asserted and switch to XTAL_CLK after Internal SYS_RST is released

Note

When the PORZ is active the CLKOUT0 is tri-stated until POK is asserted and switch to XTAL_CLK after Internal SYS_RST is released

6.4.2.2 Clock IO Mapping

Please refer to the *Terminal Configurations and Functions* section of the device-specific Datasheet.

6.4.3 IP Clocking

6.4.3.1 R5SS and SYSCLK Clock Tree

Figure *R5SS/SYSCLK Clocking* gives an overview of the R5 Subsystem and SYSCLK Clocking structure

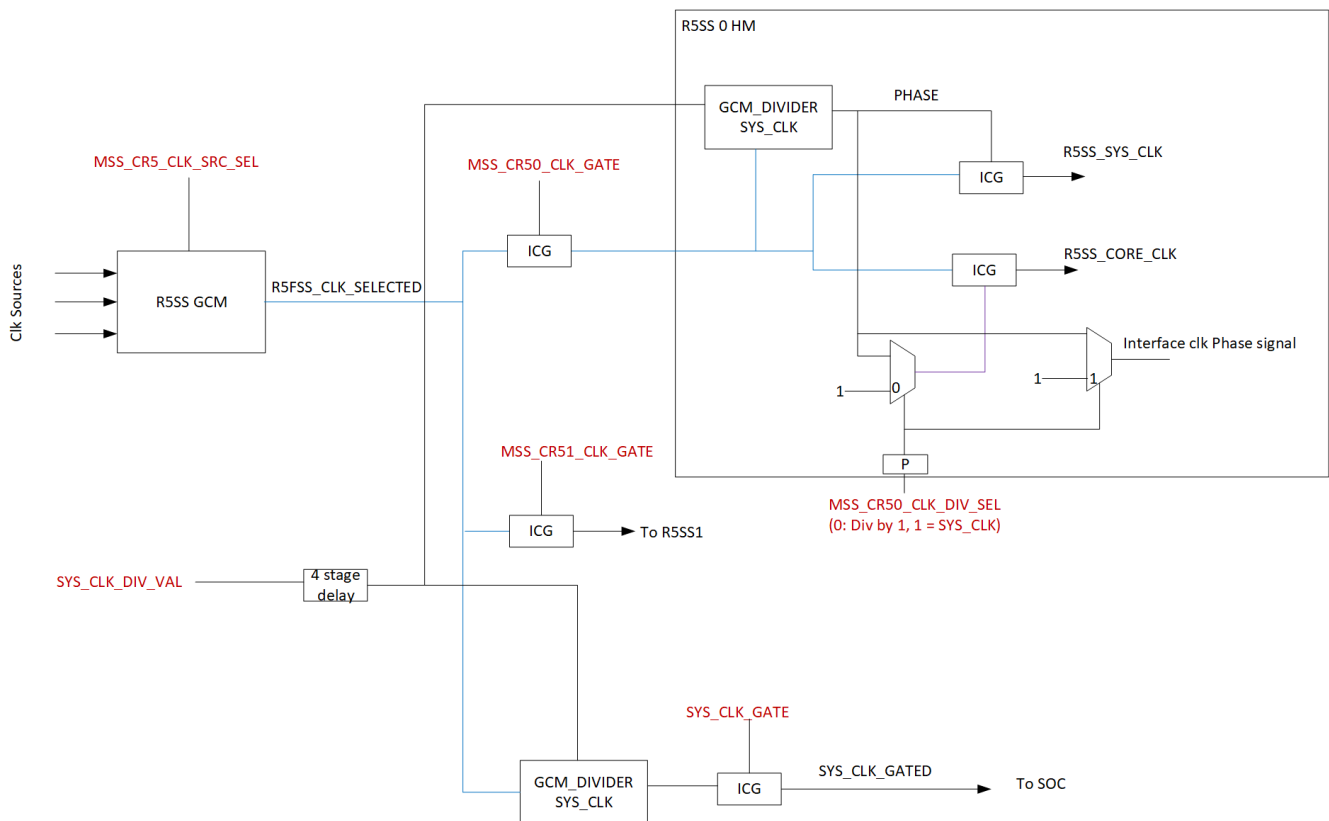

Figure 6-23. R5SS/SYSCLK Clocking

Tables *R5SS_CORE_CLK:SYSCLK Achievable Ratio* shows the different operation options concerning the ratio between R5SS_CORE_CLK and the SYSCLK

Table 6-20. R5SS_CORE_CLK:SYSCLK Achievable Ratio

R5SS_CORE_CLK:SYS_CLK Ratio	Option 1	Option 2
1:1	R5FSS_CLK_SELECTED = 400MHz SYS_CLK_DIVIDER = Div by 2 MSS_CR5*_CLK_DIV_SEL = 1	NA
2:1	R5FSS_CLK_SELECTED = 400MHz SYS_CLK_DIVIDER = Div by 2 MSS_CR5*_CLK_DIV_SEL = 0	NA

6.4.3.2 IP Clocks Having GCM

The structure is similar for all IP's having dedicated GCM's

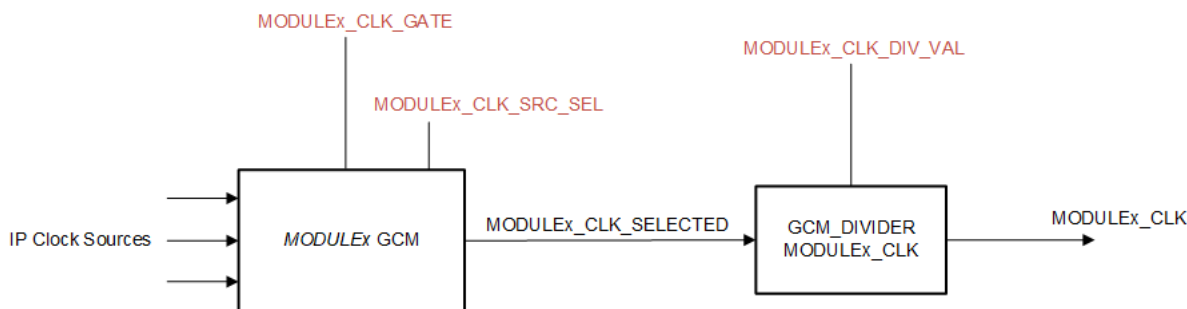

Figure 6-24. Generic IP clocking with GCM and Divider

6.4.3.3 IP Clocks Working on SYSCLK

Every IP working on SYS_CLK has a separate clock gate. In some cases the clock gate is implemented in the IP. In that case the MMR it is routed to the IP and there is no clock gate inserted at SOC. Figure [Generic IP clocking with SYS_CLK](#) shows the generic structure for every IP working with SYS_CLK.

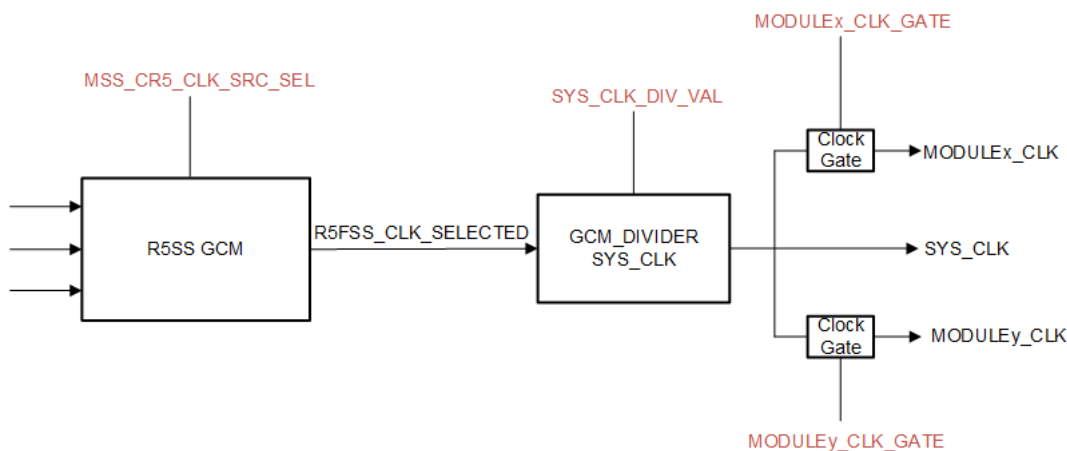

Figure 6-25. Generic IP clocking with SYS_CLK

Note

Some IP's have clock gating internal to IP. In this cases, no additional ICG is Provisioned in RCM

6.4.3.4 Clock Selection

Configuration Options Table lists the configuration options for the clock source, divider, and gating selections for different peripheral clocks.

Table 6-21. Configuration Options

Clock Muxes	Clock Sources		MMR Select	MMR Divider Select	MMR Clock Gate	IP's
R5FSS_CLK_MUX	0	XTALCLK	R5SS_CLK_SRC_SELECT	R5SS0_CLK_DIV_SELECT	R5SS0_CLK_GATE	R5SS0
	1	EXT_REFCLK				
	2	DPLL_CORE_HSDIV0_CLKOUT0				
	3	RCCLK10M		R5SS1_CLK_DIV_SELECT	R5SS1_CLK_GATE	R5SS1
	4	RCCLK10M				
	5	RCCLK10M				
	6	XTALCLK				
7	RCCLK10M					
TRC_CLKOUT_CLK_MUX	0	XTALCLK	TRCCLKOUT_CLK_SELECT	TRCCLKOUT_DIV_VAL	TRCCLKOUT_CLK_GATE	Trace
	1	DPLL_CORE_HSDIV0_CLKOUT0				
	2	DPLL_CORE_HSDIV0_CLKOUT1				
	3	DPLL_PER_HSDIV0_CLKOUT0				
	4	DPLL_PER_HSDIV0_CLKOUT1				
	5	RCCLK10M				
	6	XTALCLK				
7	RCCLK10M					
CLKOUT0_CLK_MUX	0	XTALCLK	CLKOUT0_CLK_SELECT	CLKOUT0_DIV_VAL	CLKOUT0_CLK_GATE	CLKOUT0
	1	DPLL_CORE_HSDIV0_CLKOUT0				
	2	DPLL_CORE_HSDIV0_CLKOUT1				
	3	DPLL_PER_HSDIV0_CLKOUT0				
	4	DPLL_PER_HSDIV0_CLKOUT1				
	5	RCCLK10M				
	6	RCCLK32K				
7	CTPS_GENF0					

ADVANCE INFORMATION

Table 6-21. Configuration Options (continued)

Clock Muxes	Clock Sources		MMR Select	MMR Divider Select	MMR Clock Gate	IP's
CLKOUT1_CLK_MUX	0	XTALCLK	CLKOUT1_CLK_SRC_SEL	CLKOUT1_DIV_VAL	CLKOUT1_CLK_GATE	CLKOUT1
	1	DPLL_CORE_HSDIV0_CLKOUT0				
	2	DPLL_CORE_HSDIV0_CLKOUT1				
	3	DPLL_PER_HSDIV0_CLKOUT0				
	4	DPLL_PER_HSDIV0_CLKOUT1				
	5	RCCLK10M				
	6	RCCLK32K				
	7	CTPS_GENF0				
RTI0_CLK_MUX	0	XTALCLK	RTI0_CLK_SRC_SEL	RTI0_CLK_DIV_VAL	RTI0_CLK_GATE	RTI0
	1	EXT_REFCLK				
	2	SYS_CLK				
	3	DPLL_PER_HSDIV0_CLKOUT1				
	4	DPLL_CORE_HSDIV0_CLKOUT1				
	5	RCCLK10M				
	6	XTALCLK				
	7	CTPS_GENF0				
RTI1_CLK_MUX	0	XTALCLK	RTI1_CLK_SRC_SEL	RTI1_CLK_DIV_VAL	RTI1_CLK_GATE	RTI1
	1	EXT_REFCLK				
	2	SYS_CLK				
	3	DPLL_PER_HSDIV0_CLKOUT1				
	4	DPLL_CORE_HSDIV0_CLKOUT1				
	5	RCCLK10M				
	6	XTALCLK				
	7	CTPS_GENF0				

ADVANCE INFORMATION

Table 6-21. Configuration Options (continued)

Clock Muxes	Clock Sources		MMR Select	MMR Divider Select	MMR Clock Gate	IP's
RTI2_CLK_MUX	0	XTALCLK	RTI2_CLK_SRC_SEL	RTI2_CLK_DIV_VAL	RTI2_CLK_GATE	RTI2
	1	EXT_REFCLK				
	2	SYS_CLK				
	3	DPLL_PER_HSDIV0_CLKOUT1				
	4	DPLL_CORE_HSDIV0_CLKOUT1				
	5	RCCLK10M				
	6	XTALCLK				
	7	CTPS_GENF0				
RTI3_CLK_MUX	0	XTALCLK	RTI3_CLK_SRC_SEL	RTI3_CLK_DIV_VAL	RTI3_CLK_GATE	RTI3
	1	EXT_REFCLK				
	2	SYS_CLK				
	3	DPLL_PER_HSDIV0_CLKOUT1				
	4	DPLL_CORE_HSDIV0_CLKOUT1				
	5	RCCLK10M				
	6	XTALCLK				
	7	CTPS_GENF0				
WDT0_CLK_MUX	0	XTALCLK	WDT0_CLK_SRC_SEL	WDT0_CLK_DIV_VAL	WDT0_CLK_GATE	WDT0
	1	RCCLK10M				
	2	SYS_CLK				
	3	DPLL_PER_HSDIV0_CLKOUT1				
	4	DPLL_CORE_HSDIV0_CLKOUT1				
	5	RCCLK10M				
	6	XTALCLK				
	7	RCCLK32K				

ADVANCE INFORMATION

Table 6-21. Configuration Options (continued)

Clock Muxes	Clock Sources		MMR Select	MMR Divider Select	MMR Clock Gate	IP's
WDT1_CLK_MUX	0	XTALCLK	WDT1_CLK_SRC_SELECT	WDT1_CLK_DIV_VAL	WDT1_CLK_GATE	WDT1
	1	RCCLK10M				
	2	SYS_CLK				
	3	DPLL_PER_HSDIV0_CLKOUT1				
	4	DPLL_CORE_HSDIV0_CLKOUT1				
	5	RCCLK10M				
	6	XTALCLK				
	7	RCCLK32K				
WDT2_CLK_MUX	0	XTALCLK	WDT2_CLK_SRC_SELECT	WDT2_CLK_DIV_VAL	WDT2_CLK_GATE	WDT2
	1	RCCLK10M				
	2	SYS_CLK				
	3	DPLL_PER_HSDIV0_CLKOUT1				
	4	DPLL_CORE_HSDIV0_CLKOUT1				
	5	RCCLK10M				
	6	XTALCLK				
	7	RCCLK32K				
WDT3_CLK_MUX	0	XTALCLK	WDT3_CLK_SRC_SELECT	WDT3_CLK_DIV_VAL	WDT3_CLK_GATE	WDT3
	1	RCCLK10M				
	2	SYS_CLK				
	3	DPLL_PER_HSDIV0_CLKOUT1				
	4	DPLL_CORE_HSDIV0_CLKOUT1				
	5	RCCLK10M				
	6	XTALCLK				
	7	RCCLK32K				

Table 6-21. Configuration Options (continued)

Clock Muxes	Clock Sources		MMR Select	MMR Divider Select	MMR Clock Gate	IP's
QSPI_CLK_MUX	0	XTALCLK	QSPI0_CLK_SRC_SELECT	QSPI0_CLK_DIV_VAL	QSPI0_CLK_GATE	QSPI
	1	EXT_REFCLK				
	2	SYS_CLK				
	3	DPLL_PER_HSDIV0_CLKOUT1				
	4	DPLL_CORE_HSDIV0_CLKOUT0				
	5	RCCLK10M				
	6	XTALCLK				
	7	RCCLK10M				
SPI0_CLK_MUX	0	XTALCLK	MCSPi0_CLK_SRC_SELECT	MCSPi0_CLK_DIV_VAL	MCSPi0_CLK_GATE	SPi0
	1	EXT_REFCLK				
	2	SYS_CLK				
	3	DPLL_PER_HSDIV0_CLKOUT1				
	4	DPLL_CORE_HSDIV0_CLKOUT0				
	5	RCCLK10M				
	6	XTALCLK				
	7	RCCLK10M				
SPi1_CLK_MUX	0	XTALCLK	MCSPi1_CLK_SRC_SELECT	MCSPi1_CLK_DIV_VAL	MCSPi1_CLK_GATE	SPi1
	1	EXT_REFCLK				
	2	SYS_CLK				
	3	DPLL_PER_HSDIV0_CLKOUT1				
	4	DPLL_CORE_HSDIV0_CLKOUT0				
	5	RCCLK10M				
	6	XTALCLK				
	7	RCCLK10M				

ADVANCE INFORMATION

Table 6-21. Configuration Options (continued)

Clock Muxes	Clock Sources		MMR Select	MMR Divider Select	MMR Clock Gate	IP's
SPI2_CLK_MUX	0	XTALCLK	MCSPI2_CLK_SRC_SEL	MCSPI2_CLK_DIV_VAL	MCSPI2_CLK_GATE	SPI2
	1	EXT_REFCLK				
	2	SYS_CLK				
	3	DPLL_PER_HSDIV0_CLKOUT1				
	4	DPLL_CORE_HSDIV0_CLKOUT0				
	5	RCCLK10M				
	6	XTALCLK				
	7	RCCLK10M				
SPI3_CLK_MUX	0	XTALCLK	MCSPI3_CLK_SRC_SEL	MCSPI3_CLK_DIV_VAL	MCSPI3_CLK_GATE	SPI3
	1	EXT_REFCLK				
	2	SYS_CLK				
	3	DPLL_PER_HSDIV0_CLKOUT1				
	4	DPLL_CORE_HSDIV0_CLKOUT0				
	5	RCCLK10M				
	6	XTALCLK				
	7	RCCLK10M				
SPI4_CLK_MUX	0	XTALCLK	MCSPI4_CLK_SRC_SEL	MCSPI4_CLK_DIV_VAL	MCSPI4_CLK_GATE	SPI4
	1	EXT_REFCLK				
	2	SYS_CLK				
	3	DPLL_PER_HSDIV0_CLKOUT1				
	4	DPLL_CORE_HSDIV0_CLKOUT0				
	5	RCCLK10M				
	6	XTALCLK				
	7	RCCLK10M				

Table 6-21. Configuration Options (continued)

Clock Muxes	Clock Sources		MMR Select	MMR Divider Select	MMR Clock Gate	IP's
I2C_CLK_MUX	0	XTALCLK	I2C_CLK_SRC_SEL	I2C_CLK_DIV_VAL	I2C0_CLK_GATE	I2C0
	1	EXT_REFCLK				
	2	SYS_CLK			I2C1_CLK_GATE	I2C1
	3	DPLL_PER_HSDIV0_CLKOUT1				
	4	DPLL_CORE_HSDIV0_CLKOUT0			I2C2_CLK_GATE	I2C2
	5	RCCLK10M				
	6	XTALCLK			I2C3_CLK_GATE	I2C3
	7	RCCLK10M				
UART0_CLK_MUX	0	XTALCLK	LIN0_UART0_CLK_SRC_SEL	LIN0_UART0_CLK_DIV_VAL	UART0_CLKGATE	UART0
	1	EXT_REFCLK				
	2	SYS_CLK			LIN0_CLKGATE	LIN0
	3	DPLL_PER_HSDIV0_CLKOUT1				
	4	DPLL_CORE_HSDIV0_CLKOUT0			LIN0_CLKGATE	LIN0
	5	RCCLK10M				
	6	XTALCLK			LIN0_CLKGATE	LIN0
	7	DPLL_PER_HSDIV0_CLKOUT0				
UART1_CLK_MUX	0	XTALCLK	LIN1_UART1_CLK_SRC_SEL	LIN1_UART1_CLK_DIV_VAL	UART1_CLKGATE	UART1
	1	EXT_REFCLK				
	2	SYS_CLK			LIN1_CLKGATE	LIN1
	3	DPLL_PER_HSDIV0_CLKOUT1				
	4	DPLL_CORE_HSDIV0_CLKOUT0			LIN1_CLKGATE	LIN1
	5	RCCLK10M				
	6	XTALCLK			LIN1_CLKGATE	LIN1
	7	DPLL_PER_HSDIV0_CLKOUT0				

ADVANCE INFORMATION

Table 6-21. Configuration Options (continued)

Clock Muxes	Clock Sources		MMR Select	MMR Divider Select	MMR Clock Gate	IP's
UART2_CLK_MUX	0	XTALCLK	LIN2_UART2_CLK_S RC_SEL	LIN2_UART2_CLK_DI V_VAL	UART2_CLKGATE	UART2
	1	EXT_REFCLK				
	2	SYS_CLK				
	3	DPLL_PER_HSDIV0_CLKOUT1				
	4	DPLL_CORE_HSDIV0_CLKOUT0			LIN2_CLKGATE	LIN2
	5	RCCLK10M				
	6	XTALCLK				
	7	DPLL_PER_HSDIV0_CLKOUT0				
UART3_CLK_MUX	0	XTALCLK	LIN3_UART3_CLK_S RC_SEL	LIN3_UART3_CLK_DI V_VAL	UART3_CLKGATE	UART3
	1	EXT_REFCLK				
	2	SYS_CLK				
	3	DPLL_PER_HSDIV0_CLKOUT1				
	4	DPLL_CORE_HSDIV0_CLKOUT0			LIN3_CLKGATE	LIN3
	5	RCCLK10M				
	6	XTALCLK				
	7	DPLL_PER_HSDIV0_CLKOUT0				
UART4_CLK_MUX	0	XTALCLK	LIN4_UART4_CLK_S RC_SEL	LIN4_UART4_CLK_DI V_VAL	UART4_CLKGATE	UART4
	1	EXT_REFCLK				
	2	SYS_CLK				
	3	DPLL_PER_HSDIV0_CLKOUT1				
	4	DPLL_CORE_HSDIV0_CLKOUT0			LIN4_CLKGATE	LIN4
	5	RCCLK10M				
	6	XTALCLK				
	7	DPLL_PER_HSDIV0_CLKOUT0				

ADVANCE INFORMATION

Table 6-21. Configuration Options (continued)

Clock Muxes	Clock Sources		MMR Select	MMR Divider Select	MMR Clock Gate	IP's
UART5_CLK_MUX	0	XTALCLK	LIN5_UART5_CLK_S RC_SEL	LIN5_UART5_CLK_DI V_VAL	UART5_CLKGATE	UART5
	1	EXT_REFCLK				
	2	SYS_CLK				
	3	DPLL_PER_HSDIV0_CLKOUT1				
	4	DPLL_CORE_HSDIV0_CLKOUT0				
	5	RCCLK10M				
	6	XTALCLK				
	7	DPLL_PER_HSDIV0_CLKOUT0				
ICSS_UART_CLK_MUX	0	XTALCLK	ICSSM0_UART0_CLK _SRC_SEL	ICSSM0_UART_CLK_ DIV_VAL	ICSSM0_UART_CLK_ GATE	ICSSM
	1	EXT_REFCLK				
	2	SYS_CLK				
	3	DPLL_PER_HSDIV0_CLKOUT1				
	4	DPLL_CORE_HSDIV0_CLKOUT0				
	5	RCCLK10M				
	6	XTALCLK				
	7	DPLL_PER_HSDIV0_CLKOUT0				
MCAN0_CLK_MUX	0	XTALCLK	MCAN0_CLK_SRC_S EL	MCAN0_CLK_DIV_VA L	MCAN0_CLK_GATE	MCAN0
	1	EXT_REFCLK				
	2	SYS_CLK				
	3	DPLL_PER_HSDIV0_CLKOUT1				
	4	DPLL_CORE_HSDIV0_CLKOUT0				
	5	RCCLK10M				
	6	XTALCLK				
	7	RCCLK10M				

ADVANCE INFORMATION

Table 6-21. Configuration Options (continued)

Clock Muxes	Clock Sources		MMR Select	MMR Divider Select	MMR Clock Gate	IP's
MCAN1_CLK_MUX	0	XTALCLK	MCAN1_CLK_SRC_SEL	MCAN1_CLK_DIV_VAL	MCAN1_CLK_GATE	MCAN1
	1	EXT_REFCLK				
	2	SYS_CLK				
	3	DPLL_PER_HSDIV0_CLKOUT1				
	4	DPLL_CORE_HSDIV0_CLKOUT0				
	5	RCCLK10M				
	6	XTALCLK				
	7	RCCLK10M				
MCAN2_CLK_MUX	0	XTALCLK	MCAN2_CLK_SRC_SEL	MCAN2_CLK_DIV_VAL	MCAN2_CLK_GATE	MCAN2
	1	EXT_REFCLK				
	2	SYS_CLK				
	3	DPLL_PER_HSDIV0_CLKOUT1				
	4	DPLL_CORE_HSDIV0_CLKOUT0				
	5	RCCLK10M				
	6	XTALCLK				
	7	RCCLK10M				
MCAN3_CLK_MUX	0	XTALCLK	MCAN3_CLK_SRC_SEL	MCAN3_CLK_DIV_VAL	MCAN3_CLK_GATE	MCAN3
	1	EXT_REFCLK				
	2	SYS_CLK				
	3	DPLL_PER_HSDIV0_CLKOUT1				
	4	DPLL_CORE_HSDIV0_CLKOUT0				
	5	RCCLK10M				
	6	XTALCLK				
	7	RCCLK10M				

Table 6-21. Configuration Options (continued)

Clock Muxes	Clock Sources		MMR Select	MMR Divider Select	MMR Clock Gate	IP's
MMCS0_CLK_MUX	0	XTALCLK	MMCS0_CLK_SRC_SELECT	MMCS0_CLK_DIV_VAL	MMCS0_CLK_GATE	MMC
	1	EXT_REFCLK				
	2	SYS_CLK				
	3	DPLL_PER_HSDIV0_CLKOUT1				
	4	DPLL_CORE_HSDIV0_CLKOUT0				
	5	RCCLK10M				
	6	XTALCLK				
	7	RCCLK10M				
CPTS_CLK_MUX	0	XTALCLK	CPTS_CLK_SRC_SELECT	CPTS_CLK_DIV_VAL	CPTS_CLK_GATE	CPSW
	1	EXT_REFCLK				
	2	SYS_CLK				
	3	DPLL_CORE_HSDIV0_CLKOUT1				
	4	DPLL_CORE_HSDIV0_CLKOUT0				
	5	RCCLK10M				
	6	XTALCLK				
	7	RCCLK10M				
HSM_RTI_CLK_MUX	0	XTALCLK	HSM_RTIA_CLK_SRC_SELECT	HSM_RTI_CLK_DIV_VAL	HSM_RTI_CLK_GATE	RTI
	1	XTALCLK				
	2	SYS_CLK				
	3	DPLL_PER_HSDIV0_CLKOUT1				
	4	RCCLK10M				
	5	RCCLK10M				
	6	EXT_REFCLK				
	7	RCCLK32K				

ADVANCE INFORMATION

Table 6-21. Configuration Options (continued)

Clock Muxes	Clock Sources		MMR Select	MMR Divider Select	MMR Clock Gate	IP's
HSM_WDT_CLK_MUX	0	XTALCLK	HSM_WDT_CLK_SRC_SEL	HSM_WDT_CLK_DIV_VAL	HSM_WDT_CLK_GATE	WDT
	1	XTALCLK				
	2	SYS_CLK				
	3	DPLL_PER_HSDIV0_CLKOUT1				
	4	RCCLK10M				
	5	RCCLK10M				
	6	EXT_REFCLK				
	7	RCCLK32K				
HSM_RTC_CLK_MUX	0	XTALCLK	HSM_RTC_CLK_SRC_SEL	HSM_RTC_CLK_DIV_VAL	HSM_RTC_CLK_GATE	RTC
	1	XTALCLK				
	2	SYS_CLK				
	3	DPLL_PER_HSDIV0_CLKOUT1				
	4	RCCLK10M				
	5	RCCLK10M				
	6	EXT_REFCLK				
	7	RCCLK32K				
HSM_DMTA_CLK_MUX	0	XTALCLK	HSM_DMTA_CLK_SRC_SEL	HSM_DMTA_CLK_DIV_VAL	HSM_DMTA_CLK_GATE	DMTA
	1	XTALCLK				
	2	SYS_CLK				
	3	DPLL_PER_HSDIV0_CLKOUT1				
	4	RCCLK10M				
	5	RCCLK10M				
	6	EXT_REFCLK				
	7	RCCLK32K				

ADVANCE INFORMATION

Table 6-21. Configuration Options (continued)

Clock Muxes	Clock Sources		MMR Select	MMR Divider Select	MMR Clock Gate	IP's
HSM_DMTB_CLK_MUX	0	XTALCLK	HSM_DMTB_CLK_SRC_SEL	HSM_DMTB_CLK_DIV_VAL	HSM_DMTB_CLK_GATE	DMTB
	1	XTALCLK				
	2	SYS_CLK				
	3	DPLL_PER_HSDIV0_CLKOUT1				
	4	RCCLK10M				
	5	RCCLK10M				
	6	EXT_REFCLK				
	7	RCCLK32K				
GPMC_CLK_MUX	0	XTALCLK	GPMC_CLK_SRC_SEL	GPMC_CLK_DIV_VAL	GPMC_CLK_GATE	GPMC
	1	EXT_REFCLK				
	2	SYS_CLK				
	3	DPLL_PER_HSDIV0_CLKOUT1				
	4	DPLL_CORE_HSDIV0_CLKOUT0				
	5	RCCLK10M				
	6	XTALCLK				
	7	RCCLK10M				
CONTROLSS_PLL_CLOCK_MUX	0	XTALCLK	CONTROLSS_PLL_CLOCK_SRC_SEL	CONTROLSS_PLL_CLOCK_DIV_VAL	CONTROLSS_PLL_CLOCK_GATE	ControlSS
	1	EXT_REFCLK				
	2	DPLL_CORE_HSDIV0_CLKOUT2				
	3	DPLL_PER_HSDIV0_CLKOUT1				
	4	DPLL_CORE_HSDIV0_CLKOUT0				
	5	RCCLK10M				
	6	XTALCLK				
	7	RCCLK10M				
NA	DPLL_CORE_HSDIV0_CLKOUT1		NA	RGMIID_250_CLK_DIV_VAL	RGMIID_250_CLK_GATE	CPSW
NA	DPLL_CORE_HSDIV0_CLKOUT1		NA	RGMIID_50_CLK_DIV_VAL	RGMIID_50_CLK_GATE	CPSW

ADVANCE INFORMATION

Table 6-21. Configuration Options (continued)

Clock Muxes	Clock Sources	MMR Select	MMR Divider Select	MMR Clock Gate	IP's
NA	DPLL_CORE_HSDIV0_CLKOUT1	NA	RGMII_5_CLK_DIV_VAL	RGMII_5_CLK_GATE	CPSW
NA	XTALCLK	NA	XTAL_MMC_32K_CLK_DIV_VAL	MMC0_32K_CLK_GATE	MMC 32K
NA	XTALCLK	NA	XTAL_TEMPSENSE_32K_CLK_DIV_VAL	TEMPSENSE_32K_CLK_GATE	Temp Sensor
NA	SYS_CLK	NA	MSS_ELM_CLK_DIV_VAL	MSS_ELM_CLK_GATE	MSS

6.4.3.5 IP Clock Configurations

6.4.3.5.1 RTI CLOCK

(FREQ = 200 MHz)

1. Program RTI0 *GCD* register with the value of 0x000 in-order to switch to a new desired frequency, RTI0_CLK_DIV_VAL.CLKDIV = 0x000
2. Poll for the CURRDIVR field of corresponding status register to reflect its new frequency change, RTI0_CLK_STATUS.CURRDIVIDER = 0x00
3. Update the RTI0 CLK *GCM* register with the value of 0x222 to select *SYS_CLK* as its source, RTI0_CLK_SRC_SEL.CLKSRCSEL = 0x222
4. Poll for the CLKINUSE field of corresponding status register to reflect its new frequency change, RTI0_CLK_STATUS.CLKINUSE = 0x04

6.4.3.5.2 WDT CLOCK

(FREQ = 200 MHz)

1. Program WDT0 *GCD* register with the value of 0x000 in-order to switch to a new desired frequency, WDT0_CLK_DIV_VAL.CLKDIV = 0x000
2. Poll for the CURRDIVR field of corresponding status register to reflect its new frequency change, WDT0_CLK_STATUS.CURRDIVIDER = 0x0
3. Update the MSS WDT0 *GCM* register with the value of 0x222 to select *SYS_CLK* as its source, WDT0_CLK_SRC_SEL.CLKSRCSEL = 0x222
4. Poll for the CLKINUSE field of corresponding status register to reflect its new frequency change, WDT0_CLK_STATUS.CLKINUSE = 0x04

6.4.3.5.3 QSPI CLOCK

(FREQ = 80 MHz, note – ROM is utilizing QSPI @ 40 MHz so program the *GCD* correspondingly)

1. Program QSPI *GCD* register with the value of 0x444 in-order to switch to a new desired frequency, QSPI_CLK_DIV_VAL.CLKDIV = 0x444
2. Poll for the CURRDIVR field of corresponding status register to reflect its new frequency change, QSPI_CLK_STATUS.CURRDIVIDER = 0x4
3. Update the QSPI *GCM* register with the value of 0x444 to select *PLL_CORE_CLKOUT0* clock as its source, QSPI_CLK_SRC_SEL.CLKSRCSEL = 0x444
4. Poll for the CLKINUSE field of corresponding status register to reflect its new frequency change, QSPI_CLK_STATUS.CLKINUSE = 0x10
5. Program DCLK_DIV field from the SPI_CLOCK_CNTRL register in MSS_QSPI memory map with the value of 0x00, MSS_QSPI.SPI_CLOCK_CNTRL.DCLK_DIV = 0x00

Baud rate relationship with QSPI functional clock frequency:

Baud rate = fQSPI / CLKD

Where fQSPI – QSPI Functional clock frequency
CLKD – Prescalar clock divider

6.4.3.5.4 MCSPI CLOCK

(FREQ = 50 MHz, Baud rate = 50Mbps)

1. Program MCSPI0 *GCD* register with the value of 0x333 in-order to switch to a new desired frequency, MCSPI0_CLK_DIV_VAL.CLKDIV = 0x333
2. Poll for the CURRDIVR field of corresponding status register to reflect its new frequency change, MCSPI0_CLK_STATUS.CURRDIVIDER = 0x03
3. Update the MCSPI0 *GCM* register with the value of 0x444 to select *PLL_CORE_CLKOUT0* clock as its source, MCSPI0_CLK_SRC_SEL.CLKSRCSEL = 0x444
4. Poll for the CLKINUSE field of corresponding status register to reflect its new frequency change, MCSPI0_CLK_STATUS.CLKINUSE = 0x10

5. Program the CLKD field from the required channel config register of the corresponding instance with the value of 0x1, MCSPI0.CH0CONF.CLKD = 0x1

(FREQ = 48 MHz, Baud rate = 48Mbps)

1. Program MCSPI0 GCD register with the value of 0x333 in-order to switch to a new desired frequency, MCSPI0_CLK_DIV_VAL.CLKDIV = 0x333
2. Poll for the CURRDIVR field of corresponding status register to reflect its new frequency change, MCSPI0_CLK_STATUS.CURRDIVIDER = 0x03
3. Update the MCSPI0 GCM register with the value of 0x333 to select *PLL_PER_CLKOUT1* clock as its source, MCSPI0_CLK_SRC_SEL.CLKSRCSEL = 0x333
4. Poll for the CLKINUSE field of corresponding status register to reflect its new frequency change, MCSPI0_CLK_STATUS.CLKINUSE = 0x08
5. Program the CLKD field from the required channel config register of the corresponding instance with the value of 0x1, MCSPI0.CH0CONF.CLKD = 0x1

Baud rate relationship with MCSPI functional clock frequency,

Baud rate = fSPI / CLKD

Where fSPI – SPI Functional clock frequency
CLKD – Prescalar clock divider

6.4.3.5.5 I2C CLOCK

(FREQ = 48 MHz, Baud rate = 400KHz)

1. Program I2C GCD register with the value of 0x333 in-order to switch to a new desired frequency, I2C_CLK_DIV_VAL.CLKDIV = 0x333
2. Poll for the CURRDIVR field of corresponding status register to reflect its new frequency change, I2C_CLK_STATUS.CURRDIVIDER = 0x03
3. Update the I2C GCM register with the value of 0x333 to select *PLL_PER_CLKOUT1* as its source, I2C_CLK_SRC_SEL.CLKSRCSEL = 0x333
4. Poll for the CLKINUSE field of corresponding status register to reflect its new frequency change, I2C_CLK_STATUS.CLKINUSE = 0x08
5. Program ICCL15_ICCL0 field of ICCLKL register of the corresponding I2C instance with calculated value of 0x35 to attain the 400KHz baud rate, MSS_I2C0.ICCLKL. ICCL15_ICCL0 = 0x35
6. Program ICCL15_ICCH0 field of ICCLKH register of the corresponding I2C instance with calculated value of 0x35 to attain the 400KHz baud rate, MSS_I2C0.ICCLKH. ICCL15_ICCH0 = 0x35

Baud rate relationship with I2C functional clock frequency,

$$SCL_LOW_PERIOD = [fI2C] * [IPSC+1] * [ICCL + d]$$

$$SCL_HIGH_PERIOD = [fI2C] * [IPSC+1] * [ICCH + d]$$

where fI2C – I2C functional clock frequency,
IPSC – Prescalar value

d – Constant w.r.t to prescalar (IPSC = 0,6 then d = 7, IPSC = 1,5 then d = 6)

ICCL – I2C clock low divider

ICCH – I2C clock high divider

6.4.3.5.6 LIN_UART CLOCK

(FREQ = 192 MHz)

1. Program LIN_UART GCD register with the value of 0x000 in-order to switch to a new desired frequency, LIN0_UART0_CLK_DIV_VAL.CLKDIV = 0x000
2. Poll for the CURRDIVR field of corresponding status register to reflect its new frequency change, LIN0_UART0_CLK_STATUS.CURRDIVIDER = 0x00

- Update the LIN_UART GCM register with the value of 0x333 to select *PLL_PER_CLKOUT1* as its source, LIN0_UART0_CLK_SRC_SEL.CLKSRCSEL = 0x333
- Poll for the CLKINUSE field of corresponding status register to reflect its new frequency change, LIN0_UART0_CLK_STATUS.CLKINUSE = 0x08

(FREQ = 160 MHz)

- Program LIN_UART GCD register with the value of 0x000 in-order to switch to a new desired frequency, LIN0_UART0_CLK_DIV_VAL.CLKDIV = 0x000
- Poll for the CURRDIVR field of corresponding status register to reflect its new frequency change, LIN0_UART0_CLK_STATUS.CURRDIVIDER = 0x00
- Update the LIN_UART GCM register with the value of 0x777 to select *PLL_PER_CLKOUT0* as its source, LIN0_UART0_CLK_SRC_SEL.CLKSRCSEL = 0x777
- Poll for the CLKINUSE field of corresponding status register to reflect its new frequency change, LIN0_UART0_CLK_STATUS.CLKINUSE = 0x80

For LIN, Baud rate = 20 Kbps then functional clock = 48MHz

- Program SCI_LIN_PSL field of BRSR register of the corresponding LIN instance with calculated value of 0x95 to attain the required baud rate, MSS_LIN0.BRSR.SCI_LIN_PSL = 0x95

Baud rate relationship with LIN functional clock frequency,

$$\text{Baud rate} = f_{\text{LIN}} / [16 * (P + 1 + M/16)]$$

Where FLIN – LIN Functional clock

P – Prescalar to select baudrate

M – Prescalar for fine tuning of baudrate

For UART, Baud rate = 12 Mbps then functional clock = 192MHz,

Baud rate = 10 Mbps then functional clock = 160 MHz

- Program CLOCK_LSB field of DLL register of the corresponding UART instance with calculated value of 0x1 to attain the required baud rate, MSS_UART0.DLL.CLOCK_LSB = 0x1
- Program CLOCK_MSB field of DLH register of the corresponding UART instance with calculated value of 0x0 to attain the required baud rate, MSS_UART0.DLH.CLOCK_MSB = 0x0

Baud rate relationship with LIN functional clock frequency,

$$\text{Baud rate} = f_{\text{UART}} / [16 * \text{DIV}]$$

Where FUART – UART Functional clock

DIV – Prescalar clock divider

6.4.3.5.7 ICSSM UART CLOCK

(FREQ = 192 MHz)

- Program ICSSM UART GCD register with the value of 0x000 in-order to switch to a new desired frequency, ICSSM0_UART0_CLK_DIV_VAL.CLKDIV = 0x000
- Poll for the CURRDIVR field of corresponding status register to reflect its new frequency change, ICSSM0_UART0_CLK_STATUS.CURRDIVIDER = 0x00
- Update the ICSSM UART GCM register with the value of 0x333 to select *PLL_PER_CLKOUT1* as its source, ICSSM0_UART0_CLK_SRC_SEL.CLKSRCSEL = 0x333
- Poll for the CLKINUSE field of corresponding status register to reflect its new frequency change, ICSSM0_UART0_CLK_STATUS.CLKINUSE = 0x08

6.4.3.5.8 MCAN CLOCK

(FREQ = 80 MHz, Baud Rate = 8 Mbps)

1. Program MCAN *GCD* register with the value of 0x444 in-order to switch to a new desired frequency, MCAN0_CLK_DIV_VAL.CLKDIV = 0x444
2. Poll for the CURRDIVR field of corresponding status register to reflect its new frequency change, MCAN0_CLK_STATUS.CURRDIVIDER = 0x04
3. Update the MCAN0 *GCM* register with the value of 0x444 to select *PLL_CORE_CLKOUT0* as its source, MCAN0_CLK_SRC_SEL.CLKSRCSEL = 0x444
4. Poll for the CLKINUSE field of corresponding status register to reflect its new frequency change, MCAN0_CLK_STATUS.CLKINUSE = 0x10
5. Program NBRP field of the NBTP register of the corresponding CAN instance with the calculated value of 0x0 to achieve the required baud rate of 8Mbps, MSS_MCAN0.NBTP.NBRP = 0x0
6. Program NTSEG1 field of the NBTP register of the corresponding CAN instance with the value calculated from the formula to achieve the required baud rate, MSS_MCAN0.NTSEG1.NBRP = 0x1
7. Program NTSEG2 field of the NBTP register of the corresponding CAN instance with the value calculated from the formula to achieve the required baud rate, MSS_MCAN0.NTSEG2.NBRP = 0x1

Baud rate relationship with CAN functional clock frequency,

$$\text{Baud rate} = f_{\text{CAN}} / [2 * (\text{BRP} + 1) * (3 + \text{TSEG1} + \text{TSEG2})]$$

Where f_{CAN} – MCAN Functional clock frequency

BRP – Baudrate prescaler

TSEG1 – Time segment before sample point

TSEG2 – Time segment after sample point

6.4.3.5.9 MMC0 CLOCK

(FREQ = 50 MHz)

1. Program MMCSD *GCD* register with the value of 0x333 in-order to switch to a new desired frequency, MMC0_CLK_DIV_VAL.CLKDIV = 0x333
2. Poll for the CURRDIVR field of corresponding status register to reflect its new frequency change, MMC0_CLK_STATUS.CURRDIVIDER = 0x03
3. Update the MMC0 *GCM* register with the value of 0x444 to select *PLL_PER_CLKOUT1* as its source, MMC0_CLK_SRC_SEL.CLKSRCSEL = 0x444
4. Poll for the CLKINUSE field of corresponding status register to reflect its new frequency change, MMC0_CLK_STATUS.CLKINUSE = 0x10

(FREQ = 48 MHz)

1. Program MMCSD *GCD* register with the value of 0x111 in-order to switch to a new desired frequency, MMC0_CLK_DIV_VAL.CLKDIV = 0x333
2. Poll for the CURRDIVR field of corresponding status register to reflect its new frequency change, MMC0_CLK_STATUS.CURRDIVIDER = 0x03
3. Update the MMC0 *GCM* register with the value of 0x333 to select *PLL_PER_CLKOUT1* as its source, MMC0_CLK_SRC_SEL.CLKSRCSEL = 0x333
4. Poll for the CLKINUSE field of corresponding status register to reflect its new frequency change, MMC0_CLK_STATUS.CLKINUSE = 0x08

6.4.3.5.10 CPTS CLOCK

(FREQ = 250 MHz)

1. Program CPTS *GCD* register with the value of 0x111 in-order to switch to a new desired frequency, CPTS_CLK_DIV_VAL.CLKDIV = 0x111
2. Poll for the CURRDIVR field of corresponding status register to reflect its new frequency change, CPTS_CLK_STATUS.CURRDIVIDER = 0x01
3. Update the CPTS *GCM* register with the value of 0x333 to select *PLL_PER_CLKOUT1* as its source, CPTS_CLK_SRC_SEL.CLKSRCSEL = 0x333
4. Poll for the CLKINUSE field of corresponding status register to reflect its new frequency change, CPTS_CLK_STATUS.CLKINUSE = 0x08

6.4.3.5.11 HSM RTI CLOCK

(FREQ = 200 MHz)

1. Program HSM RTI *GCD* register with the value of 0x000 in-order to switch to a new desired frequency, HSM_RTI_CLK_DIV_VAL.CLKDIV = 0x000
2. Poll for the CURRDIVR field of corresponding status register to reflect its new frequency change, HSM_RTI_CLK_STATUS.CURRDIVIDER = 0x00
3. Update the HSM RTI *GCM* register with the value of 0x222 to select *SYS_CLK* as its source, HSM_RTI_CLK_SRC_SEL.CLKSRCSEL = 0x222
4. Poll for the CLKINUSE field of corresponding status register to reflect its new frequency change, HSM_RTI_CLK_STATUS.CLKINUSE = 0x04

6.4.3.5.12 HSM WDT CLOCK

(FREQ = 200 MHz)

1. Program HSM WDT *GCD* register with the value of 0x000 in-order to switch to a new desired frequency, HSM_WDT_CLK_DIV_VAL.CLKDIV = 0x000
2. Poll for the CURRDIVR field of corresponding status register to reflect its new frequency change, HSM_WDT_CLK_STATUS.CURRDIVIDER = 0x00
3. Update the HSM WDT *GCM* register with the value of 0x222 to select *SYS_CLK* as its source, HSM_WDT_CLK_SRC_SEL.CLKSRCSEL = 0x222
4. Poll for the CLKINUSE field of corresponding status register to reflect its new frequency change, HSM_WDT_CLK_STATUS.CLKINUSE = 0x04

6.4.3.5.13 HSM RTC CLOCK

(FREQ = 32 KHz)

1. Program HSM RTC *GCD* register with the value of 0x000 in-order to switch to a new desired frequency, HSM_RTC_CLK_DIV_VAL.CLKDIV = 0x000
2. Poll for the CURRDIVR field of corresponding status register to reflect its new frequency change, HSM_RTC_CLK_STATUS.CURRDIVIDER = 0x00
3. Update the HSM RTC *GCM* register with the value of 0x777 to select *RCCLK32K* as its source, HSM_RTC_CLK_SRC_SEL.CLKSRCSEL = 0x777
4. Poll for the CLKINUSE field of corresponding status register to reflect its new frequency change, HSM_RTC_CLK_STATUS.CLKINUSE = 0x80

6.4.3.5.14 HSM DMTA CLOCK

(FREQ = 200 MHz)

1. Program HSM DMTA *GCD* register with the value of 0x000 in-order to switch to a new desired frequency, HSM_DMTA_CLK_DIV_VAL.CLKDIV = 0x000
2. Poll for the CURRDIVR field of corresponding status register to reflect its new frequency change, HSM_DMTA_CLK_STATUS.CURRDIVIDER = 0x00
3. Update the HSM DMTA *GCM* register with the value of 0x222 to select *SYS_CLK* as its source, HSM_DMTA_CLK_SRC_SEL.CLKSRCSEL = 0x222
4. Poll for the CLKINUSE field of corresponding status register to reflect its new frequency change, HSM_DMTA_CLK_STATUS.CLKINUSE = 0x04

6.4.3.5.15 HSM DMTB CLOCK

(FREQ = 200 MHz)

1. Program HSM DMTB *GCD* register with the value of 0x000 in-order to switch to a new desired frequency, HSM_DMTB_CLK_DIV_VAL.CLKDIV = 0x000
2. Poll for the CURRDIVR field of corresponding status register to reflect its new frequency change, HSM_DMTB_CLK_STATUS.CURRDIVIDER = 0x00
3. Update the HSM DMTB *GCM* register with the value of 0x222 to select *SYS_CLK* as its source, HSM_DMTB_CLK_SRC_SEL.CLKSRCSEL = 0x222

- Poll for the CLKINUSE field of corresponding status register to reflect its new frequency change, HSM_DMTB_CLK_STATUS.CLKINUSE = 0x04

6.4.3.5.16 GPMC CLOCK

(FREQ = 100 MHz)

- Program GPMC CLK GCD register with the value of 0x111 in-order to switch to a new desired frequency, GPMC_CLK_DIV_VAL.CLKDIV = 0x111
- Poll for the CURRDIVR field of corresponding status register to reflect its new frequency change, GPMC_CLK_STATUS.CURRDIVIDER = 0x01
- Update the GPMC GCM register with the value of 0x222 to select SYS_CLK as its source, GPMC_CLK_SRC_SEL.CLKSRCSEL = 0x222
- Poll for the CLKINUSE field of corresponding status register to reflect its new frequency change, GPMC_CLK_STATUS.CLKINUSE = 0x04

6.4.3.5.17 CONTROLSS PLL CLOCK

(FREQ = 400 MHz)

- Program CONTROLSS PLL CLOCK GCD register with the value of 0x111 in-order to switch to a new desired frequency, CONTROLSS_PLL_CLK_DIV_VAL.CLKDIV = 0x000
- Poll for the CURRDIVR field of corresponding status register to reflect its new frequency change, CONTROLSS_PLL_CLK_STATUS.CURRDIVIDER = 0x00
- Update the GPMC GCM register with the value of 0x333 to select PLL_CORE_CLKOUT2 clock as its source, CONTROLSS_PLL_CLK_SRC_SEL.CLKSRCSEL = 0x222
- Poll for the CLKINUSE field of corresponding status register to reflect its new frequency change, CONTROLSS_PLL_CLK_STATUS.CLKINUSE = 0x04

6.4.3.5.18 RGMII5 CLK

(FREQ = 5 MHz, Default configuration)

- Program RGMII5 GCD register with the value of 0x636363 to obtain a new desired frequency divided from PLL_CORE_CLKOUT1, RGMII5_CLK_DIV_VAL.CLKDIV = 0x636363
- Poll for the CURRDIVR field of corresponding status register to reflect its new frequency change, RGMII5_CLK_STATUS.CURRDIVIDER = 0x63

6.4.3.5.19 RGMII50 CLK

(FREQ = 50 MHz, Default configuration)

- Program RGMII50 GCD register with the value of 0x999 to obtain a new desired frequency divided from PLL_CORE_CLKOUT1, RGMII50_CLK_DIV_VAL.CLKDIV = 0x999
- Poll for the CURRDIVR field of corresponding status register to reflect its new frequency change, RGMII50_CLK_STATUS.CURRDIVIDER = 0x09

6.4.3.5.20 RGMII250 CLK

(FREQ = 250 MHz, Default configuration)

- Program RGMII250 GCD register with the value of 0x111 to obtain a new desired frequency divided from PLL_CORE_CLKOUT1, RGMII250_CLK_DIV_VAL.CLKDIV = 0x111
- Poll for the CURRDIVR field of corresponding status register to reflect its new frequency change, RGMII250_CLK_STATUS.CURRDIVIDER = 0x01

6.4.3.5.21 XTAL MMC 32K CLOCK

(FREQ = 32 KHz, Default configuration)

- Program XTAL MMC 32K GCD register with the value of 0x30CC330C to obtain a new desired frequency divided from XTAL_CLK, XTAL_MMC_32K_CLK_DIV_VAL.CLKDIV = 0x30CC330C
- Poll for the CURRDIVR field of corresponding status register to reflect its new frequency change, XTAL_MMC_32K_CLK_STATUS.CURRDIVIDER = 0x30C

6.4.3.5.22 XTAL TEMPESENSE 32K CLOCK

(FREQ = 32 KHz, Default configuration)

1. Program XTAL TEMPESENSE 32K GCD register with the value of 0x30CC330C to obtain a new desired frequency divided from XTAL_CLK,

```
XTAL_TEMPESENSE_32K_CLK_DIV_VAL.CLKDIV = 0x30CC330C
```

1. Poll for the CURRDIVR field of corresponding status register to reflect its new frequency change, XTAL_TEMPESENSE_32K_CLK_STATUS.CURRDIVIDER = 0x30C

6.4.3.5.23 MSS_ELM CLOCK

(FREQ = 50 MHz, Default configuration)

1. Program MSS ELM GCD register with the value of to obtain a new desired frequency divided from SYS_CLK, MSS_LM_CLK_DIV_VAL.CLKDIV = 0x03
2. Poll for the CURRDIVR field of corresponding status register to reflect its new frequency change, MSS_ELM_CLK_STATUS.CURRDIVIDER = 0x03

6.4.4 Limp Mode

A dedicate coarse clock loss logic checks the XTAL clock against the RC CLK continuously to detect if the XTAL clock is toggling.

When this module detects a clock error on XTAL Clock, the error signal is routed to the GCM's to activate the Limp mode. When the limp mode is activated, all the GCM switch to RCCLK (clk source #5). This ensures the CPU continues to operate even if the XTAL Clock fails and can take the system to a safe state.

Switch to Limp mode feature is not enabled by default. It needs to be explicitly enabled by S/W by TOP_RCM.LIMP_MODE_EN.XTALCLK_LOSS_EN

Note

RC_CLK is not an accurate clock and hence the performance of the system is not guaranteed in Limp mode.

6.4.5 Clocking Registers

For additional details related to device clocking registers, please refer to the *Control - RCM Registers* section.

Chapter 7
Processors and Accelerators



This chapter describes the Processor and Accelerator modules in the device.

7.1 Arm Cortex R5F Subsystem (R5FSS)

This chapter describes the Arm Cortex R5F real-time microcontroller unit subsystem (R5FSS) in the device.

7.1.1 R5FSS Overview.....	240
7.1.2 R5FSS Integration.....	242

7.1.1 R5FSS Overview

The R5FSS is a dual-core implementation of the Arm® Cortex®-R5F processor configured for Dual-Core or Lockstep operation. It also includes accompanying memories (L1 caches and tightly-coupled memories), standard Arm CoreSight™ debug and trace architecture, integrated vectored interrupt manager (VIM), ECC aggregators, and various other modules for protocol conversion and address translation for easy integration into the SoC.

Note

The Cortex-R5F processor is a Cortex-R5 processor that includes the optional floating point unit (FPU) extension. In this TRM, all references to the Cortex-R5 processor apply to the Cortex-R5F processor by default.

7.1.1.1 R5FSS Features

Each R5FSS supports the following features:

- Dual-core Arm Cortex-R5F
 - Core revision: r1p3
 - Armv7-R profile
 - Dual-core and Lockstep mode support
 - Dual-core mode: Two independently operating cores (asymmetric multi processing, no coherence)
 - Lockstep mode: One operating core (CORE0) and One lockstep core (CORE1)
 - CORE0 uses TCM resources of both cores
 - CORE1 caches and interrupts are unused in this mode
 - Support for switching to Dual-core mode from Lockstep mode by application (Efuse-enabled feature) - by triggering a CPU reset. (See device specific Datasheet for additional details.)
 - L1 memory system
 - 16KB instruction cache
 - 4x4KB ways
 - SECDED ECC protected per 64 bits
 - 16KB data cache
 - 4x4KB ways
 - SECDED ECC protected per 32 bits
 - 64KB tightly-coupled memory (TCM) per CPU
 - SECDED ECC protected per 32 bits
 - Readable/writable from system
 - Split into A and B banks (with B further splitting into B0 and B1 interleaved banks)
 - 32KB TCMA (ATCM)
 - 16KB TCMB0 (B0TCM)
 - 16KB TCMB1 (B1TCM)
 - In Dual-Core mode, TCM is 64KB in total (per core):
 - 32KB TCMA
 - 16KB TCMB0 + 16KB TCMB1
 - In Lockstep mode, TCM is 128KB in total:
 - 64KB TCMA
 - 32KB TCMB0 + 32KB TCMB1
 - Full-precision floating point (VFPv3)
 - 16 region memory protection unit (MPU)
 - 8 breakpoints
 - 8 watchpoints
 - Dynamic branch prediction with global history buffer and 4-entry return stack
 - CoreSight debug access port (DAP)
 - CoreSight embedded trace macrocell (ETM-R5) interface

- Performance monitoring unit (PMU)
- Interfaces
 - 64-bit VBUSM initiator pair (1 read, 1 write) for L2 memory accesses (per core)
 - 64-bit VBUSM target for TCM access (per core)
 - Also allows access to cache for debug purposes
 - 32-bit VBUSP initiator for peripheral access (per core)
 - 4x 32-bit VBUSP target configuration port (2x ECC Aggregator + 1x CCMR + 1x STC)
 - 32-bit VBUSP target debug port
 - Allows access to all R5FSS internal debug logic
- Synchronous clock domain crossing on all interfaces
 - CPU and interface clocks run at a 2:1 frequency ratio
- Integrated vectored interrupt manager (VIM)
 - 256 interrupts per core
 - Only interrupts connected to R5F CORE0 are available in Lockstep mode
 - Each interrupt programmable as either IRQ or FIQ
 - Each interrupt has a programmable enable mask
 - Each interrupt has a programmable 4-bit priority
 - Priority interrupt supported
 - Vectored interrupt interface
 - Compatible with R5F VIC port
 - Programmable 32-bit vector address per interrupt
 - Address is SECEDED error protected
 - Default vector addresses provided on DED
 - Dual-Core or Lockstep capable
 - Software interrupt generation
- Integrated ECC aggregators
 - Support for error injection to all supported ECC memory blocks to test ECC functionality (add-on function from TI)
 - One ECC aggregator per core to cover all RAMs and caches associated with that core
- Standard Arm CoreSight debug and trace architecture at the R5FSS level
 - Cross triggering: Supported by cross trigger interface (CTI) (per CORE) and cross trigger matrix (CTM) components
 - Processor trace: Supported by embedded trace macrocell (ETM) (per CORE) and advanced trace bus (ATB) funnel components

See [Section 7.1.3](#) for a functional block diagram and additional details related to the R5FSS.

7.1.1.2 R5FSS Not Supported Features

The R5FSS does *not* support the following native R5F features in this device:

- ACP port (no coherence)
- Bus parity / ECC
- Multiple power domains

7.1.2 R5FSS Integration

This section describes the R5FSS integration in the device, including information about clocks, resets, and hardware requests.

7.1.2.1 R5FSS Integration (AM263x)

There are 2x R5FSS modules integrated in the device. The diagram below provides a visual representation of the device integration details.

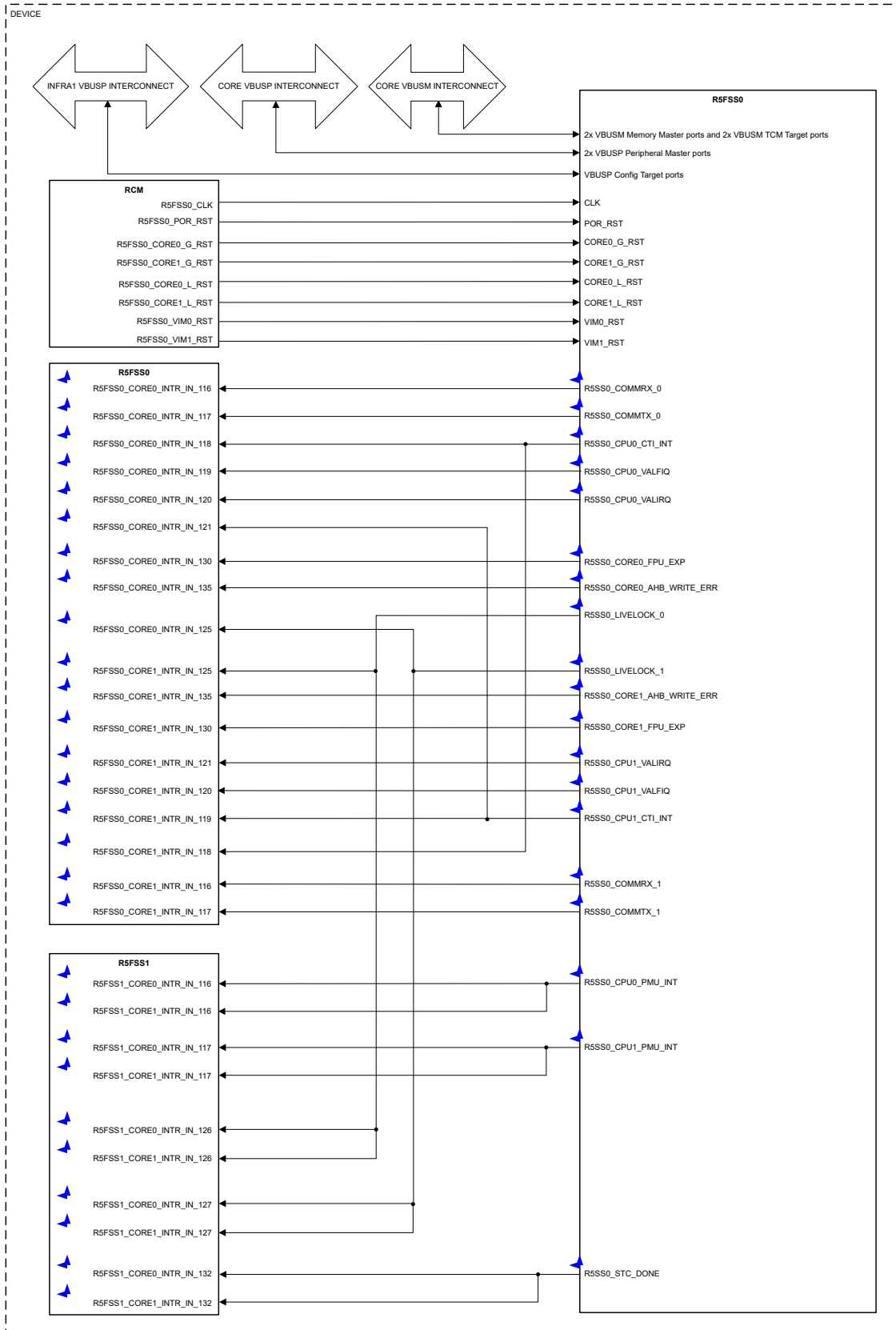

ADVANCE INFORMATION

Figure 7-1. R5FSS0 Integration Diagram

ADVANCE INFORMATION

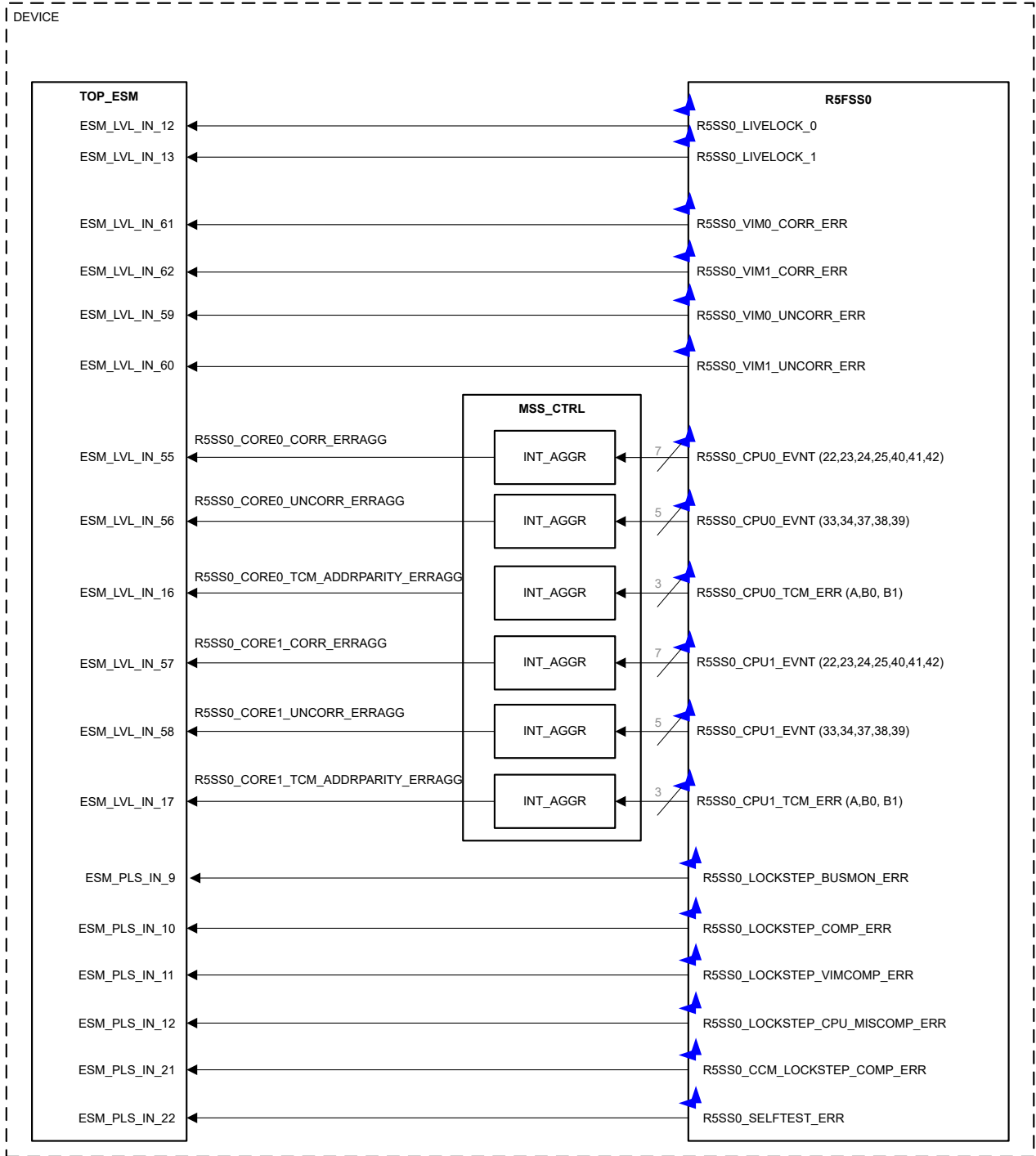

Figure 7-2. R5FSS0 Integration Diagram Continued

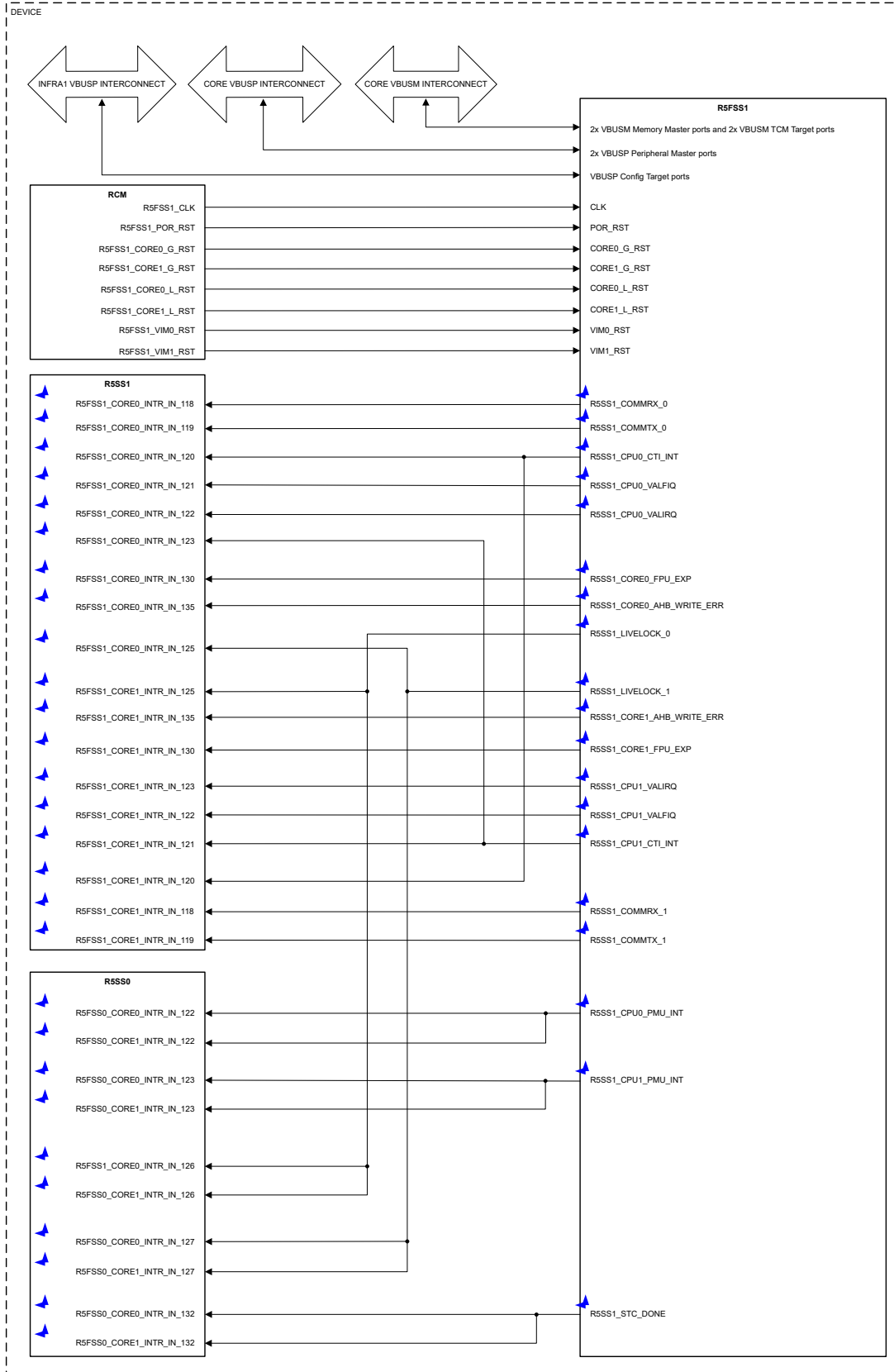

Figure 7-3. R5FSS1 Integration Diagram

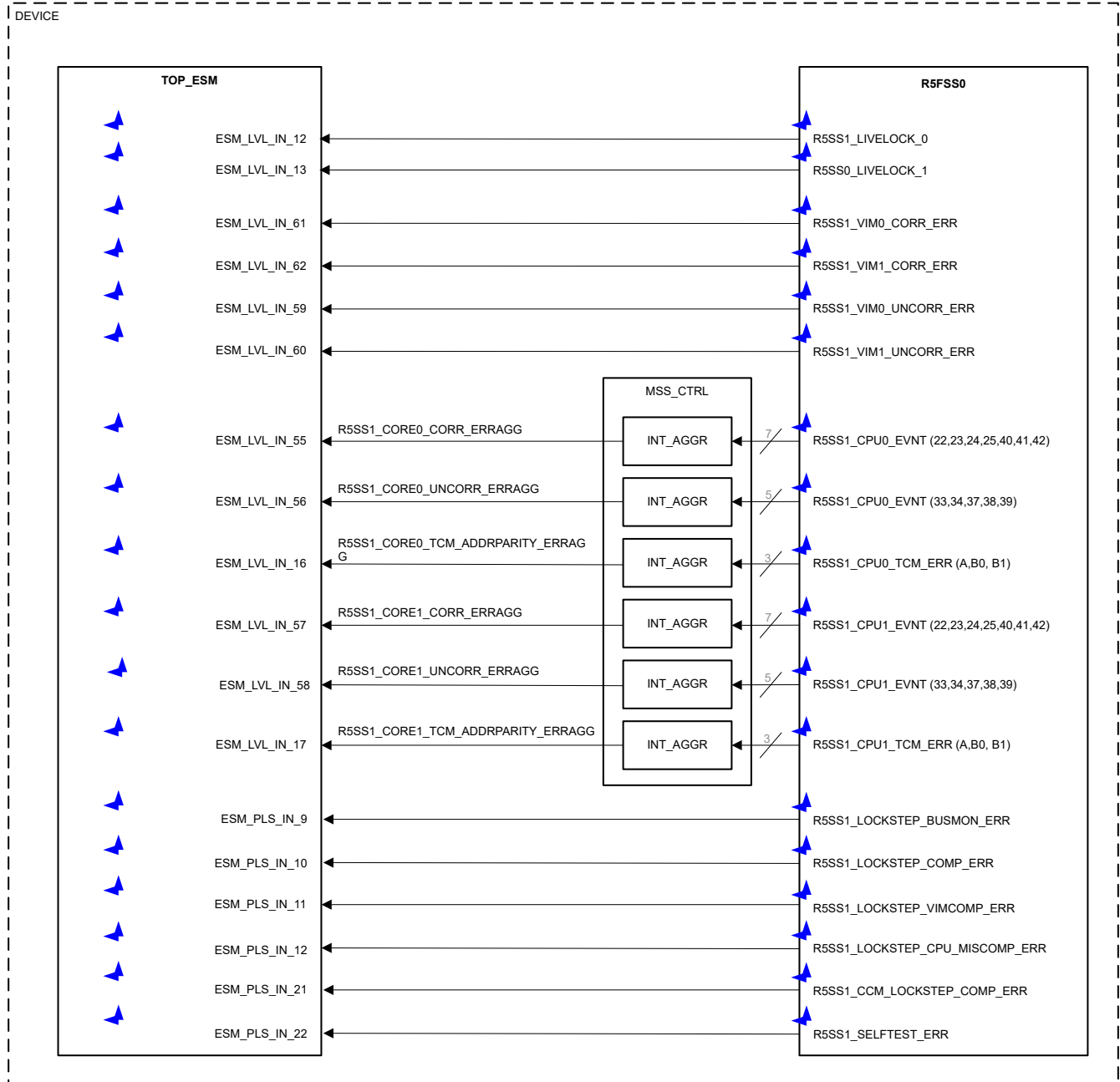

Figure 7-4. R5FSS1 Integration Diagram Continued

The tables below summarize the device integration details of R5FSS0/1.

Table 7-1. R5FSS0/1 Device Integration

This table describes the module device integration details.

Module Instance	SoC Interconnect
R5FSS0/1 CORE0/1	CORE VBUSM Interconnect CORE VBUSP Interconnect INFRA1 VBUSP Interconnect

Table 7-2. R5FSS0/1 Clocks

This table describes the module clocking signals.

Module Instance	Module Clock Input	Source Clock Signal	Source	Description
R5FSS0	CLK	R5FSS0_CLK	MSS_RCM	Functional Clock. Interface clock is derived from functional clock
R5FSS1	CLK	R5FSS1_CLK	MSS_RCM	Functional Clock. Interface clock is derived from functional clock

Table 7-3. R5FSS0/1 Resets

Module Instance	Module Reset Input	Source Reset Signal	Source	Description
R5FSS0	POR_RST	R5FSS0_POR_RST	MSS_RCM	R5FSS0 Power on Reset
	CORE0_G_RST	R5FSS0_CORE0_G_RST	MSS_RCM	R5FSS0 Core0 Subsystem reset
	CORE1_G_RST	R5FSS0_CORE1_G_RST	MSS_RCM	R5FSS0 Core1 Subsystem reset
	CORE0_L_RST	R5FSS0_CORE0_L_RST	MSS_RCM	R5SS0 Core0 Local Reset
	CORE1_L_RST	R5FSS0_CORE1_L_RST	MSS_RCM	R5SS0 Core1 Local Reset
	VIM0_RST	R5FSS0_VIM0_RST	MSS_RCM	R5FSS0 VIM0 Reset
	VIM1_RST	R5FSS0_VIM1_RST	MSS_RCM	R5FSS0 VIM1 Reset
R5FSS1	POR_RST	R5FSS1_POR_RST	MSS_RCM	R5FSS1 Power on Reset
	CORE0_RST	R5FSS1_CORE0_G_RST	MSS_RCM	R5FSS1 Core0 Main reset
	CORE1_RST	R5FSS1_CORE1_G_RST	MSS_RCM	R5FSS1 Core1 Main reset
	CORE0_L_RST	R5FSS1_CORE0_L_RST	MSS_RCM	R5SS0 Core0 Local Reset
	CORE1_L_RST	R5FSS1_CORE1_L_RST	MSS_RCM	R5SS0 Core1 Local Reset
	VIM0_RST	R5FSS1_VIM0_RST	MSS_RCM	R5FSS1 VIM0 Reset
	VIM1_RST	R5FSS1_VIM1_RST	MSS_RCM	R5FSS1 VIM1 Reset

Table 7-4. R5FSS0/1 Hardware Requests

Module Instance	Module Interrupt Signal	Destination Interrupt Input	Destination	Description	Type
R5FSS0	R5FSS0 CORE0 Interrupts				
	R5SS0_COMMRX_0	R5FSS0_CORE0_IN TR_IN_116	R5FSS0_CORE0	R5FSS0 CORE0 DTRRX Full Interrupt	Level
	R5SS0_COMMTX_0	R5FSS0_CORE0_IN TR_IN_117	R5FSS0_CORE0	R5FSS0 CORE0 DTRTX Empty Interrupt	Level
	R5SS0_CPU0_CTI_IN T			R5FSS0 CORE0 Cross trigger Interrupt	
	R5SS0_CPU0_VALFIQ				
	R5SS0_CPU0_VALIRQ				
	R5SS0_CORE0_FPU_ EXP				
	R5SS0_CORE0_AHB_ WRITE_ERR				
	R5SS0_LIVELOCK_0				
	R5SS0_CPU0_PMU_I NT				
	R5SS0_COMMRX_1				
	R5SS0_COMMTX_1				
	R5SS0_CPU1_CTI_IN T				
	R5SS0_CPU1_VALFIQ				
	R5SS0_CPU1_VALIRQ				
	R5SS0_CORE1_FPU_ EXP				
	R5SS0_CORE1_AHB_ WRITE_ERR				
	R5SS0_LIVELOCK_1				
	R5SS0_CPU1_PMU_I NT				
	R5SS0_STC_DONE				
	R5FSS0 CORE1 Interrupts				
R5FSS1	R5FSS1 CORE0 Interrupts				
	R5FSS1 CORE0 Interrupts				

Table 7-5. MODULE Interrupt Requests

This table describes the module interrupt requests.

Module Instance	Module Interrupt Signal	Destination Interrupt Input	Destination	Type	Description
MODULE0	TBD	TBD	TBD	TBD	TBD

Table 7-6. MODULE DMA Requests

This table describes the module DMA requests.

Module Instance	Module DMA Event	Destination DMA Event Input	Destination	Type	Description
MODULE0	TBD	TBD	TBD	TBD	TBD

Table 7-7. MODULE Capture Event Inputs

This table describes the module capture event inputs.

Module Instance	Module Capture Event Input	Capture Event Source Signal	Source	Type	Description
MODULE0	TBD	TBD	TBD	TBD	TBD

Note

For more information on the interconnects, see the *System Interconnect* chapter.

For more information on power, reset, and clock management, see the corresponding sections within the *Device Configuration* chapter.

For more information on the device interrupt controllers, see the *Interrupt Controllers* chapter.

7.1.3 R5FSS Functional Description

7.1.3.1 R5FSS Block Diagram

Figure 7-5 shows the R5FSS block diagram.

ADVANCE INFORMATION

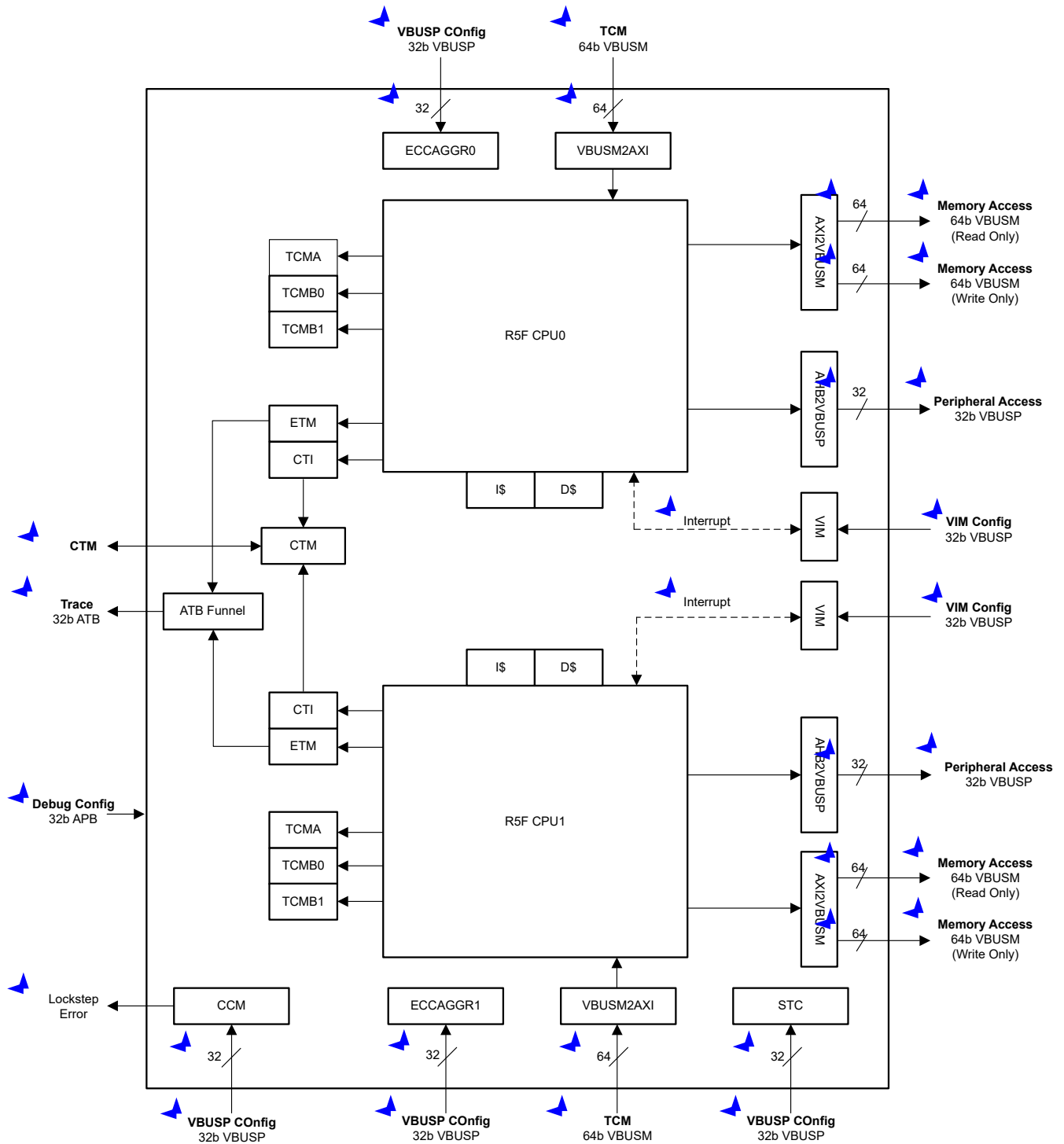

Figure 7-5. R5FSS Block Diagram

7.1.3.2 R5FSS Cortex-R5F Core

The Cortex-R5F is a processor from Arm, which is based on the Armv7-R profile. Each R5FSS implements two R5F cores, CPU0 and CPU1, each with their own RAMs and interfaces. While in reset, they can be bootstrapped to work in one of two modes: Dual-Core or Lockstep.

In dual core mode, each R5F core works completely independent from the other (asymmetric multi-processing, or AMP). Each core uses its own RAMs and interfaces, with no coherence between the two cores. The only restriction is that CPU0 must be in a higher power/reset state than CPU1. For instance, CPU1 cannot be out of reset if CPU0 is not.

In Lockstep mode:

- CPU0 is the only operating core
- CPU1 operates as the lockstep core for CPU0
- CPU1 TCMs are stacked on CPU0 TCMs and are accessible only by CPU0 and CPU0 TCM interface
- The TCM size for CPU0 is essentially doubled in this mode (128KB)
- CPU1 caches and interrupts are not used

For a brief list of features supported by the R5F processor in this device, see [Section 7.1.1.1](#). For more detailed description of this processor, see the *Arm Cortex-R5 Technical Reference Manual*.

7.1.3.2.1 L1 Caches

The R5F has a Harvard cache architecture, which means it has an independent L1 instruction cache (16KB) and L1 data cache (16KB). The instruction cache is protected by SECDED ECC per 64 bits. The data cache is protected by SECDED ECC per 32 bits.

7.1.3.2.2 Tightly-Coupled Memories (TCMs)

The R5F has two tightly-coupled memories (TCMs), ATCM and BTCM. The BTCM is further broken down into two interleaved banks, B0TCM and B1TCM.

TCMs are low-latency, tightly integrated memories for the R5F to use. Either TCM can be used for any combination of instruction and/or data. TCM performance is equal to performance on instructions/data that are in cache. However, TCMs have some additional advantages over cache. TCMs can be loaded with instructions that do not cache well (such as ISRs) or preloaded with code by an external source, before that code is needed, to save cache miss time. TCMs are also a good place for blocks of data for intense processing. They can be loaded (or pre-loaded by an external source) before the data is needed, saving cache miss time. The data can then be directly accessed by an external source, instead of needing to do cache evicts.

As mentioned, TCMs can be accessed (either read or written) by an external source over the TCM VBUSM slave interface. This allows instructions or data to be preloaded, or for data to be read out after the R5F has processed it. The VBUSM slave has a lower priority to accessing TCMs than the R5F but care must be taken to keep an external source from reading or writing TCM data that the R5F is working on. This handshaking is external to any of the R5FSS hardware.

TCMs are protected by ECC per 32 bits. For this to work, ECC must be enabled before data is written in to the TCMs (either externally or from the R5F). ECC is enabled via the following R5F system control bits: ACTLR.ATCMPCEN, ACTLR.B0TCMPCEN, and ACTLR.B1TCMPCEN, respectively.

Whether or not the TCMs are enabled is controlled by the ENABLE bit in the corresponding ATCM/BTCM region register. The default (reset) value of this bit is determined by the CPU_n_INITRAMA and CPU_n_INITRAMB bootstrap signals having a default value of 1 in this device. Both ATCM and BTCM are configured for a size of 32KB in this device. Note that the BTCM size is the total of both B0TCM and B1TCM (16KB each). Note also that the ATCM and BTCM sizes for CPU0 is 64KB each in Lockstep mode.

If a TCM is not enabled, then it does not appear in the R5F's memory view, but it can be accessed by an external source. If a TCM is enabled, then its place in the R5F memory map is determined by a combination of bootstrap signal and system register. If the CPU_n_LOCZRAMA bootstrap signal is high, then the initial base address of ATCM is 0x0000_0000 and the initial address of BTCM is 0x0008_0000. If the CPU_n_LOCZRAMA

bootstrap signal is low, then the initial base address of BTCM is 0x0000_0000 and the initial base address of ATCM is 0x0008_0000.

Note

This base address of 0x0008_0000 for ATCM/BTCM based on the CPU_n_LOCZRAMA bootstrap only affects the R5F's memory view. The SoC will see the ATCM/BTCM based on the TCM slave interface regions, as defined in [Section 7.1.3.3.2](#). The base address of either TCM may be overwritten via the ATCM or BTCM region register. Care must be taken not to move the base address of a TCM when it may be being accessed.

It is possible to preload a TCM with instructions and boot from it. See [Section 7.1.3.10](#) for details on TCM booting.

7.1.3.2.3 R5FSS Special Signals

[Table 7-8](#) through [Table 7-9](#) list some R5FSS features associated with special signals.

Table 7-8. R5FSS0 Special Features

Feature	Comment
Cluster affinity group ID	R5F Cluster 0 (ID = 0x0)
Exception handling state at reset 0 = Arm 1 = Thumb	Controlled via CTRLMMR register setting. Defaults to Arm mode
Dual core or Lockstep mode 0 = Dual Core mode 1 = Lockstep mode	Controlled via CTRLMMR register setting. Defaults to a value defined by eFuse
CPU _n execution halt when coming out of reset (CPU _n _HALT)	Controlled via CTRLMMR register setting. Defaults to halted state
CPU _n exception vectors base address	Controlled via CTRLMMR register setting. Defaults to Bootvector RAM address 0x0000_0000
CPU _n VIM base address	0x50F0 0000
CPU _n ATCM enable at reset (CPU _n _INITRAMA)	Controlled via CTRLMMR register setting. Defaults to enabled state
CPU _n BTCM enable at reset (CPU _n _INITRAMB)	Controlled via CTRLMMR register setting. Defaults to enabled state
CPU _n A/BTCM reset base address indicator (CPU _n _LOCZRAMA) 0 = B at 0x0 1 = A at 0x0	Controlled via CTRLMMR register setting. Defaults to 1
CPU _n non-maskable fast interrupts enable	Disabled
CPU _n VBUSM peripheral port enabled at reset	Disabled
CPU _n VBUSP peripheral port enable at reset	Controlled via CTRLMMR register setting Defaults to Enabled state
CPU _n VBUSP peripheral port base address	Controlled via CTRLMMR register setting. Defaults to 0x5000_0000
CPU _n VBUSP peripheral port size	Controlled via CTRLMMR register setting. Defaults to 256MB 0x5000_0000 to 0x5FFFF_FFFF
CPU _n VBUSM normal peripheral port base address	Not used
CPU _n VBUSM normal peripheral port size	Not used
CPU _n VBUSM virtual peripheral port base address	Not used
CPU _n VBUSM virtual peripheral port size	Not used
CPU _n WFI state	Status logged into CTRLMMR register bit
CPU _n WFE state	Status logged into CTRLMMR register bit

Table 7-8. R5FSS0 Special Features (continued)

Feature	Comment
CPU Clockgate Control	Controlled via RCM register setting. Individual Core clocks can be gated
CPU _n TCM Bus Parity	Enabled

Table 7-9. R5FSS1 Special Features

Feature	Comment
Cluster affinity group ID	R5F Cluster 1 (ID = 0x1)
Exception handling state at reset 0 = Arm 1 = Thumb	Controlled via CTRLMMR register setting. Defaults to Arm mode
Dual core or Lockstep mode 0 = Dual Core mode 1 = Lockstep mode	Controlled via CTRLMMR register setting. Defaults to a value defined by eFuse
CPU _n execution halt when coming out of reset (CPU _n _HALT)	Controlled via CTRLMMR register setting. Defaults to halted state
CPU _n exception vectors base address	Controlled via CTRLMMR register setting. Defaults to Bootvector RAM address 0x0000_0000
CPU _n VIM base address	0x50F0 0000
CPU _n ATCM enable at reset (CPU _n _INITRAMA)	Controlled via CTRLMMR register setting. Defaults to enabled state
CPU _n BTCM enable at reset (CPU _n _INITRAMB)	Controlled via CTRLMMR register setting. Defaults to enabled state
CPU _n A/BTCM reset base address indicator (CPU _n _LOCZRAMA) 0 = B at 0x0 1 = A at 0x0	Controlled via CTRLMMR register setting. Defaults to 1
CPU _n non-maskable fast interrupts enable	Disabled
CPU _n VBUSM peripheral port enabled at reset	Disabled
CPU _n VBUSP peripheral port enable at reset	Controlled via CTRLMMR register setting Defaults to Enabled state
CPU _n VBUSP peripheral port base address	Controlled via CTRLMMR register setting. Defaults to 0x5000_0000
CPU _n VBUSP peripheral port size	Controlled via CTRLMMR register setting. Defaults to 256MB 0x5000_0000 to 0x5FFFF_FFFF
CPU _n VBUSM normal peripheral port base address	Not used
CPU _n VBUSM normal peripheral port size	Not used
CPU _n VBUSM virtual peripheral port base address	Not used
CPU _n VBUSM virtual peripheral port size	Not used
CPU _n WFI state	Status logged into CTRLMMR register bit
CPU _n WFE state	Status logged into CTRLMMR register bit
CPU Clockgate Control	Controlled via RCM register setting. Individual Core clocks can be gated
CPU _n TCM Bus Parity	Enabled

7.1.3.3 R5FSS Interfaces

7.1.3.3.1 Master Interfaces

The R5FSS has several controller interfaces per core:

- 64-bit VBUSM controller pair (1 read, 1 write) for L2 memory accesses; this is the main memory interface
- 32-bit VBUSP controller for peripheral access

- Includes logic that provides the R5F CPU with a private access to VIM
- Enabled at reset

7.1.3.3.2 Target Interfaces

The R5FSS has several target interfaces that define its internal memory space:

- 32-bit VBUSP configuration target (per core)
 - ECC aggregator block
- 64-bit TCM target (per core)
 - ATCM
 - BTCM
 - Instruction cache RAMs
 - Data cache RAMs
- 32-bit VBUSP Configuration target
 - Lockstep Compare block
 - Selftest Logic Block
- 32-bit debug target
 - Provides access to all R5FSS internal debug logic

The TCM target interface provides direct access to the TCM RAMs. Access to the RAMs is arbitrated with access from the R5F's L1 memory system. Excessive access while the R5F is also attempting access will degrade performance.

The TCM target interface provides access to the cache RAMs for testing purposes. Access to the cache RAMs can only be done while the caches are disabled and should only be done for test purposes.

In addition to the target interfaces, there are peripherals (VIM) that are only accessible by the R5F. The R5F has an access to these modules via the VBUSP peripheral interface.

7.1.3.4 R5FSS Power, Clocking and Reset

7.1.3.4.1 R5FSS Power

R5FSS is powered by the SOC Core logic supply.

7.1.3.4.2 R5FSS Clocking

The R5FSS has a single clock Input. CLK : This is the clock source for R5FSS.

Internally, CPU0 and CPU1 clocks are generated from this clock with individual clock gate control per Core. The interface clocks are derived from this clock internally through suitable division.

The Interface clock is an integer ratio of the CPU clock. The permitted ratio are 1:1 and 1:2 for CPU_CLK:INTERFACE_CLK. The Interface clk shall not exceed 200Mhz.

7.1.3.4.3 R5FSS Reset

The R5FSS has seven reset inputs:

- POR_RST : This is the reset for the full R5FSS including debug logic
- CORE0_G_RST : This resets the entire CPU0 logic including its associated VIM except the debug logic.
- CORE1_G_RST: This resets the entire CPU1 logic including its associated VIM except the debug logic
- CORE0_L_RST : This resets CPU0 core
- CORE1_L_RST : This resets CPU1 core
- VIM0_RST : This resets VIM0
- VIM1_RST: This resets VIM1

The above resets can be controlled through RCM registers.

In addition to the reset signals, there are two halt signals:

- CORE0_HALT
- CORE1_HALT

These halt signals keep the CPUs from fetching instructions when they come out of reset. The main use is to have the CPUs halted until the TCMs are loaded (when booting from TCM), though halt could be used for any other purpose.

7.1.3.5 R5FSS Vectored Interrupt Manager (VIM)

Note

For additional details related to the R5FSS VIM, refer to the [Section 10.2.1](#) interrupt controller section of the *Interrupts* chapter.

7.1.3.6 R5FSS ECC Support

The R5F provides native ECC and parity support on all related memories, generating and checking the redundancy automatically. The methods for checking and reporting errors are available in the *Arm Cortex-R5 Technical Reference Manual*.

The R5FSS adds the capability of testing this logic by allowing errors (single and double bit) to be injected into memories (for testing purposes) via an ECC aggregator (per core). Note that because the R5FSS ECC aggregator is only used in error-injection mode for R5 related memories, it only supports a subset of the generic ECC aggregator functionality for R5 memories. However, the ECC aggregator supports full ECC aggregator functionality for VIM memories.

For a detailed description of the generic ECC aggregator functionality, see [Section 13.6.2](#), *ECC Aggregator*. For register descriptions of R5FSS CPU0 and CPU1 ECC aggregators, see and , respectively.

[Table 7-10](#) provides the RAM ID for each core. This is needed for bit field [10-0] ECC_VECTOR in the corresponding R5FSS_CPU0_VECTOR / R5FSS_CPU1_VECTOR register (part of the ECC aggregator register space).

Table 7-10. RAM ID Map for ECC Aggregator (Per Core)

RAM ID	Memory Name
0	CPU0/1 ITAG RAM0
1	CPU0/1 ITAG RAM1
2	CPU0/1 ITAG RAM2
3	CPU0/1 ITAG RAM3
4	CPU0/1 IDATA BANK0
5	CPU0/1 IDATA BANK1
6	CPU0/1 IDATA BANK2
7	CPU0/1 IDATA BANK3
8	CPU0/1 DTAG RAM0
9	CPU0/1 DTAG RAM1
10	CPU0/1 DTAG RAM2
11	CPU0/1 DTAG RAM3
12	CPU0/1 DDIRTY RAM
13	CPU0/1 DDATA RAM0
14	CPU0/1 DDATA RAM1
15	CPU0/1 DDATA RAM2
16	CPU0/1 DDATA RAM3
17	CPU0/1 DDATA RAM4
18	CPU0/1 DDATA RAM5
19	CPU0/1 DDATA RAM6
20	CPU0/1 DDATA RAM7
21	CPU0/1 ATCM BANK0

Table 7-10. RAM ID Map for ECC Aggregator (Per Core) (continued)

RAM ID	Memory Name
22	CPU0/1 ATCM BANK1
23	CPU0/1 B0TCM BANK0
24	CPU0/1 B0TCM BANK1
25	CPU0/1 B1TCM BANK0
26	CPU0/1 B1TCM BANK1
27	CPU0/1 VIM RAM

7.1.3.7 R5FSS Memory View

The memory view of each R5F (that is, the memory map as seen by each R5F) is a function of several things:

- Exception vector bootstrap: The R5F exception table (including boot vector) is always 32 bytes at address 0x00000000 as seen by the R5F.
- TCM locations: TCMs can be enabled or disabled and located at different places in the memory map, depending on bootstrap configuration. In addition, the TCM size varies depending on the mode of CPU being in Dual core or lockstep mode. For more details, see [Section 7.1.3.2.2](#).
- Peripheral interface locations: Peripherals are accessed at address 0x5000_0000 over the VBUSP peripheral interface.

The combination of the above determines what the R5F sees where in the memory map, and over what interface different transactions come out. Every transaction that does not directly address a TCM or a peripheral interface comes over the main memory interface.

See [Chapter 2, Memory Map](#), for the complete R5F memory view for this device.

7.1.3.8 R5FSS Interrupts

All interrupts and events generated by the R5FSS are summarized in [Section 7.1.2](#), along with their mapping. They can be divided into the following groups:

- R5F CPU internal interrupts and events: these include the R5 EVENT signals and PMU interrupts. These are described in *Arm Cortex-R5 Technical Reference Manual*.
- ECC aggregator interrupts: only VIM memory errors generate the interrupt. These are described in the *ECC Aggregator* chapter.
- TCM Address parity Error Interrupts: these are described in the *TCM Address Parity Error* section.
- Lockstep Compare Interrupts: these are described in the *Lockstep Compare* section.
- Selftest Logic Interrupt: interrupts and errors generated by selftest logic. These are described in the *Selftest Logic* section.

7.1.3.9 R5FSS Debug and Trace

The R5FSS supports standard Arm CoreSight debug and trace architecture. For more details, see the *On-chip Debug* chapter.

7.1.3.10 R5FSS Boot Options

R5FSS boots from 0x0000_0000 located in TCM. When the processor exits reset, it fetches the boot vector from this location.

The software must take the following steps:

1. Assert the correct bootstraps
 - a. Enable the ATCM (set CPU_n_INITRAMA) or BTCM (set CPU_n_INITAMB). Default state is both are enabled and no additional configuration needed in this device
 - b. Assert CPU_n_LOCZRAMA properly for the desired TCMA. Default state is to boot from ATCM in this device.
2. Assert CPU_n_HALT. Default is HALTED state.

3. Release the CPU from reset.
4. Load the desired code into the TCM via the TCM slave port.
 - a. Exception vectors should be located at address 0x00000000 of TCM.
5. De-assert CPU_n_HALT.

7.1.3.11 R5FSS Events

The R5F core generates several events as part of event bus. That can be monitored by the PMU for debugging. The R5 core event bus only signals event when it is enabled. Non-invasive or invasive debug mode needs to be enabled to enable the PMU counters.

The export of the events to the event bus can be enabled by setting the X bit in the Performance Monitor Control Register of the R5 core. For more details, refer to Arm R5 TRM.

7.1.3.11.1 R5FSS Core Memory ECC Events

The memory ECC-related events from the event bus are aggregated in MSS_CTRL and exported to ESM for monitoring as shown in *R5FSS Integration*.

There are four ECC interrupts to the ESM that aggregate different categories of ECC events:

- CPU0 correctable error or single bit error
- CPU1 Correctable error or single but error
- CPU0 Uncorrectable error or multi bit error
- CPU1 Uncorrectable error or multibit error

Table 7-11. R5 Event Bus Correctable Error or Single-bit Error

EVENT BUS Bit #	Description	Associated Status Register in MSS_CTRL
40	ATCM single-bit ECC error	R5SS*_CPU*_ECC_CORR_ERRAGG_STATUS[0] R5SS*_CPU*_ATCM_CORR_ERR
42	B1TCM single-bit ECC error	R5SS*_CPU*_ECC_CORR_ERRAGG_STATUS[1] R5SS*_CPU*_B1TCM_CORR_ERR
41	B0TCM single-bit ECC error	R5SS*_CPU*_ECC_CORR_ERRAGG_STATUS[2] R5SS*_CPU*_B0TCM_CORR_ERR
24	Data cache tag or dirty RAM parity error or correctable ECC error, from data-side or ACP	R5SS*_CPU*_ECC_CORR_ERRAGG_STATUS[3] R5SS*_CPU*_DTAG_CORR_ERR
25	Data cache data RAM parity error or correctable ECC error	R5SS*_CPU*_ECC_CORR_ERRAGG_STATUS[4] R5SS*_CPU*_DDATA_CORR_ERR
22	Instruction cache tag RAM parity or correctable ECC error	R5SS*_CPU*_ECC_CORR_ERRAGG_STATUS[5] R5SS*_CPU*_ITAG_CORR_ERR
23	Instruction cache data RAM parity or correctable ECC error	R5SS*_CPU*_ECC_CORR_ERRAGG_STATUS[6] R5SS*_CPU*_IDATA_CORR_ERR

Table 7-12. R5 Event Bus Uncorrectable Error or Multi-bit Error

EVENT BUS Bit #	Description	Associated Status Register in MSS_CTRL
37	ATCM multi-bit ECC error	R5SS*_CPU*_ECC_UNCORR_ERRAGG_STATUS[0] R5SS*_CPU*_ATCM_UNCORR_ERR
39	B1TCM multi-bit ECC error	R5SS*_CPU*_ECC_UNCORR_ERRAGG_STATUS[1] R5SS*_CPU*_B1TCM_UNCORR_ERR
38	B0TCM multi-bit ECC error	R5SS*_CPU*_ECC_UNCORR_ERRAGG_STATUS[2] R5SS*_CPU*_B0TCM_UNCORR_ERR
34	Data caches tag/dirty RAM fatal ECC error, from data-side or ACP.	R5SS*_CPU*_ECC_UNCORR_ERRAGG_STATUS[3] R5SS*_CPU*_DTAG_UNCORR_ERR

Table 7-12. R5 Event Bus Uncorrectable Error or Multi-bit Error (continued)

EVENT BUS Bit #	Description	Associated Status Register in MSS_CTRL
33	Data cache data RAM fatal ECC error	R5SS*_CPU*_ECC_UNCORR_ERRAGG_STATUS[4] R5SS*_CPU*_DDATA_UNCORR_ERR

7.1.3.12 R5FSS TCM Address Parity Error

R5FSS in this device is configured to generate TCM address and control bus parity. Parity error detection logic in the R5FSS detects if there is any parity error on TCM address bus. These errors are aggregated in the MSS_CTRL module and one interrupt per CPU is exported to ESM.

Table 7-13. R5 TCM Address Parity Error

Description	Associated Status Register in MSS_CTRL
ATCM bus Address parity Error	R5SS*_CPU*_TCM_ADDRPARITY_ERRAGG_STATUS [0] R5SS*_CPU*_ATCM*_PARITY_ERR
B0TCM bus Address parity Error	R5SS*_CPU*_TCM_ADDRPARITY_ERRAGG_STATUS [1] R5SS*_CPU*_B0TCM*_PARITY_ERR
B1TCM bus Address parity Error	R5SS*_CPU*_TCM_ADDRPARITY_ERRAGG_STATUS [2] R5SS*_CPU*_B1TCM*_PARITY_ERR

R5SS*_CPU*_TCM_ADDRPARITY_ERRAGG_STATUS_RAW: Provides raw status of TCM address Parity Error for each CPU Core

R5SS*_CPU*_TCM_ADDRPARITY_ERRAGG_STATUS: Provides masked status of TCM Address Parity Error for each CPU Core

R5SS*_CPU*_TCM_ADDRPARITY_ERRAGG_MASK: Mask register for TCM Address Parity Error

The register R5SS*_TCM_ADDRPARITY_CLR clears Parity Error interrupt.

The registers R5SS*_CORE*_ADDRPARITY_ERR_*TCM provides the Address location where the TCM address error occurred.

The R5SS*_TCM_ADDRPARITY_ERRFORCE register can be used to force error on TCM Address parity Error detection logic for diagnostic purpose.

R5FSS Lockstep Compare

This chapter describes the CPU compare module for the ARM® Cortex®-R5F (CCM-R5F). Each R5F subsystem (R5FSS) in the device implements two instances of the Cortex-R5F CPU that are running in lockstep to detect faults that may result in unsafe operating conditions. The CCM-R5F detects faults and signals them to the SOC error signaling module.

7.1.3.13.1 Overview	259
7.1.3.13.2 Module Operation	260
7.1.3.13.3 Control Registers	268

7.1.3.13.1 Overview

Safety-critical applications require run-time detection of faults in critical components in the device such as the Central Processing Unit (CPU) and the Vectored Interrupt Controller Module (VIM). For this purpose, the CPU Compare Module for Cortex-R5F (CCM-R5F) compares the core bus outputs of two Cortex-R5F CPUs running in a 1oo1D (one-out-of-one, with diagnostics) lockstep configuration. Each R5FSS also implements two VIM modules in 1oo1D (one-out-of-one, with diagnostic) lockstep configuration. Any difference in the core compare bus outputs of the CPUs or the VIMs is flagged as an error. For diagnostic purposes, the CCM-R5F also incorporates a self-test capability to allow for boot time checking of hardware faults within the CCM-R5F itself.

In addition to comparing the CPU's and VIM's outputs for fault detection during run-time, the CCM-R5F also incorporates one additional run-time diagnostic feature: the Checker-CPU Inactivity Monitor.

The Checker-CPU inactivity monitor monitors the checker CPU's key bus signals to the interconnect. When the two CPUs are in lockstep configuration, several key bus signals from the checker CPU which would have indicated a valid bus transaction to the interconnect on the microcontroller will be monitored. A list of the signals to be monitored is provided in [Table 7-18](#). These signals from the checker CPU are expected to be inactive. All transactions between the lockstep CPUs and the rest of the system should only go through the main CPU. Any signals which indicate activity will be flagged as an error.

7.1.3.13.1.1 Main Features

The main features of the CCM-R5F are:

- Run-time detection of faults
 - Run-time compare of CPU's outputs
 - Run-time compare of VIM's outputs
 - Run-time inactivity monitor on the checker CPU's bus signals to the interconnect
- self-test capability
- error forcing capability

7.1.3.13.1.2 Block Diagram

[Figure 7-6](#) shows the interconnect diagram of the CCM-R5F with the two Cortex-R5F CPUs and the two VIMs. The core bus outputs of the CPUs are compared in the CCM-R5F. To avoid common mode impacts, the signals of the CPUs to be compared are temporally diverse. The output signals of the master CPU are delayed 2 cycles while the input signals of checker CPU are delayed 2 cycles. The two cycle delay strategy is also deployed between the two VIM modules. While in lockstep mode, the checker CPU's output signals to the system are clamped to inactive safe values. Key signals which would have indicated a valid bus transaction to the interconnect are monitored by the CCM-R5F. The same approach is used for the key power domains if inactive signals indicate that bus masters inside these power domains are asserting valid bus transactions.

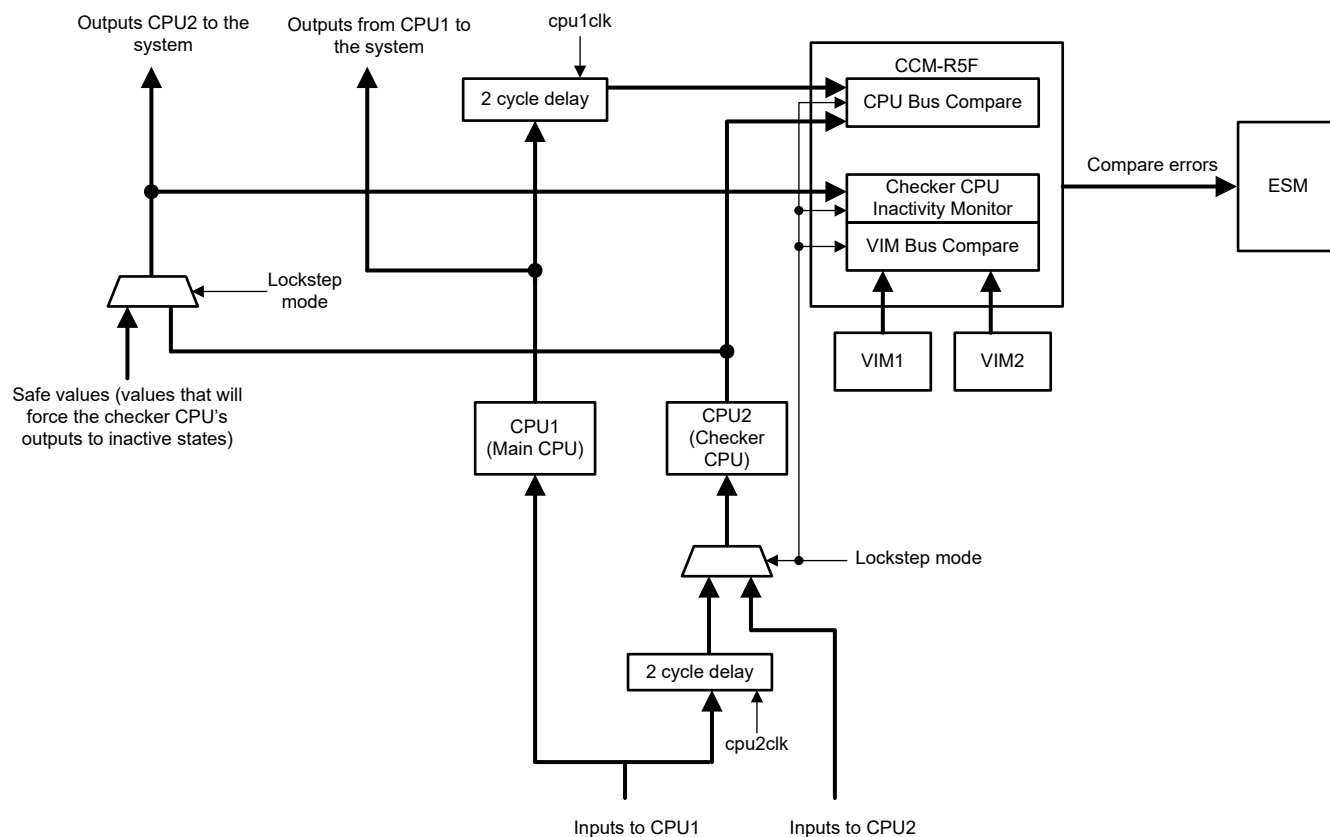

Figure 7-6. Block Diagram

7.1.3.13.2 Module Operation

As described in [Section 7.1.3.13.1](#), there are three different run-time diagnostics supported by the CCM-R5F. The CCM-R5F compares the core bus outputs of the master and checker Cortex-R5F CPUs on the microcontroller and signals an error on any mismatch. This comparison is started 6 CPU clock cycles after the CPU comes out of reset to ensure that CPU output signals have propagated to a known value after reset. Once comparison is started, the CCM module continues to monitor the outputs of the two CPUs without any software intervention. If an error is detected by the CCM-R5F, a software handler is necessary to implement the appropriate response to the error dependent on application needs. The module principles of operation are applicable to both the CPU output compare as described above as well as to the VIM output compare.

ADVANCE INFORMATION

7.1.3.13.2.1 CPU/VIM Output Compare Diagnostic

CPU / VIM Output Compare Diagnostic can run in one of the following four operating modes:

1. Active compare lockstep mode
2. Self-test
3. Error forcing
4. Self-test error forcing

The operating mode can be selected by writing a dedicated key to the key register (MKEYx) of the corresponding diagnostic.

Note

MKEY1 and MKEY2 are used to select the operating mode for the CPU Output Compare Diagnostic and VIM Output Compare Diagnostic, respectively.

7.1.3.13.2.1.1 Active Compare lockstep Mode

This is the default mode on start-up. In lockstep mode, the bus output signals of both CPUs and VIMs are compared. A difference in the CPU compare bus outputs is indicated by signaling an error to the ESM, which sets the error flag "CCM-R5F - CPU compare" and "CCM-R5F - VIM compare", respectively.

- CPU types of output signals to be compared:
 - Global signals
 - Interrupt signals
 - All L1 cache interface signals
 - All cache coherency signals
 - All L1 TCM interface signals
 - All L2 AXI interface signals
 - ETM interface signals
 - FPU signals
 - All ACP interface signals
 - All AXI Peripheral port interface signals
 - All AHB Peripheral port interface signals
 - All status and control signals
- VIM output signals to be compared:
 - nFIQ
 - nIRQ
 - IRQADDRV
 - IRQVECTADDR

Note

The CPU compare error asserts "CCM-R5F self-test error" flag as well. By doing this, the CPU compare error has two paths ("CCM-R5F - CPU compare" and "CCM-R5F self-test error" flag) to the ESM, so that even if one of the paths fails, the error is still propagated to the ESM. This is also true for "CCM-R5F - VIM compare" error flag.

Not all internal registers of the Cortex-R5F CPU have fixed values upon reset. To avoid an erroneous CCM-R5F compare error, the application software needs to ensure that the CPU registers of both CPUs are initialized with the same values before the registers are used, including function calls where the register values are pushed onto the stack.

7.1.3.13.2.1.2 Self-Test Mode

In self-test mode, the CCM-R5F checks itself for faults. During self-test, the compare error module output signal is deactivated. Any fault detected inside the CCM-R5F will be flagged by ESM error "CCM-R5F - self-test".

In self-test mode, the CCM-R5F automatically generates test patterns to look for any hardware faults. If a fault is detected, then a self-test error flag is set, a self-test error signal is asserted and sent to the ESM, and the self-test is terminated immediately. If no fault is found during self-test, the self-test complete flag is set. In both cases, the CCM-R5F CPU / VIM Output Compare Diagnostic remains in self-test mode after the test has been terminated or completed, and the application needs to switch the CCM-R5F mode by writing another key to the mode key register (MKEY1 or MKEY2 depending which diagnostic is selected for self-test). During the self-test operation, the compare error signal output to the ESM is inactive irrespective of the compare result.

There are two types of patterns generated by CCM-R5F during self-test mode:

1. Compare Match Test
2. Compare Mismatch Test

CCM-R5F first generates Compare Match Test patterns, followed by Compare Mismatch Test patterns. Each test pattern is applied on both CPU signal inputs of the CCM-R5F's compare block and clocked for one cycle. The duration of self-test for CPU Output Compare Diagnostic is 4947 CPU clock cycles (GCLK1) and 151 system peripheral clock cycles (VCLK) for VIM Output Compare Diagnostic.

Note

During self-test, both CPUs can execute normally, but the compare logic will not be checking any CPU signals. Also during self-test, only the compare unit logic is tested and not the memory-mapped register controls for the CCM-R5F. The self-test is not interruptible.

Self-test of all different diagnostics can be run at the same time.

7.1.3.13.2.1.2.1 Compare Match Test

During the Compare Match Test, there are four different test patterns generated to stimulate the CCM-R5F. An identical vector is applied to both input ports at the same time expecting a compare match. These patterns cause the self-test logic to exercise every CPU compare bus output signal in parallel. If the compare unit produces a compare mismatch then the self-test error flag is set, the self-test error signal is generated, and the Compare Match Test is terminated.

The four test patterns used for the Compare Match Test are:

- All 1s on both CPU / VIM signal ports
- All 0s on both CPU / VIM signal ports
- 0xAs on both CPU / VIM signal ports
- 0x5s on both CPU / VIM signal ports

These four test patterns will take four clock cycles to complete. [Table 7-14](#) illustrates the sequence of Compare Match Test.

Table 7-14. Compare Match Test Sequence

CPU 1 (Main CPU) Signal Position									CPU 2 (Checker CPU) Signal Position									Cycle
n:8	7	6	5	4	3	2	1	0	n:8	7	6	5	4	3	2	1	0	
1s	1	1	1	1	1	1	1	1	1s	1	1	1	1	1	1	1	1	0
0s	0	0	0	0	0	0	0	0	0s	0	0	0	0	0	0	0	0	1
0xA	1	0	1	0	1	0	1	0	0xA	1	0	1	0	1	0	1	0	2
0x5	0	1	0	1	0	1	0	1	0x5	0	1	0	1	0	1	0	1	3

7.1.3.13.2.1.2.2 Compare Mismatch Test

During the Compare Mismatch Test, the number of test patterns is equal to twice the number of CPU output signals to compare in lockstep mode. An all 1s vector is applied to the CCM-R5F's CPU1 / VIM1 input port and the same pattern is also applied to the CCM-R5F's CPU2 / VIM2 input port but with one bit flipped starting from signal position 0. The unequal vector will cause the CCM-R5F to expect a compare mismatch at signal

position 0, if the CCM-R5F logic is working correctly. If, however, the CCM-R5F logic reports a compare match, the self-test error flag is set, the self-test error signal is asserted, and the Compare Mismatch Test is terminated.

This Compare Mismatch Test algorithm repeats in a domino fashion with the next signal position flipped while forcing all other signals to logic level 1. This sequence is repeated until every single signal position is verified on both CPU signal ports.

The Compare Mismatch Test is terminated if the CCM-R5F reports a compare match versus the expected compare mismatch. This test ensures that the compare unit is able to detect a mismatch on every CPU signal being compared. [Table 7-15](#) illustrates the sequence of Compare Mismatch Test. There is no error signal sent to ESM if the expected errors are seen with each pattern.

Table 7-15. CPU / VIM Compare Mismatch Test Sequence

CPU 1 (Main CPU) Signal Position										CPU 2 (Checker CPU) Signal Position										Cycle						
n	n-1:8			7	6	5	4	3	2	1	0	n	n-1:8			7	6	5	4		3	2	1	0		
1	1	1s			1	1	1	1	1	1	1	1	1	1	1s			1	1	1	1	1	1	1	0	0
1	1	1s			1	1	1	1	1	1	1	1	1	1	1s			1	1	1	1	1	1	0	1	1
1	1	1s			1	1	1	1	1	1	1	1	1	1	1s			1	1	1	1	1	0	1	1	2
1	1	1s			1	1	1	1	1	1	1	1	1	1	1s			1	1	1	1	0	1	1	1	3
::																										
1	1	1s			1	1	1	1	1	1	1	1	0	1	1s			1	1	1	1	1	1	1	1	-1
1	1	1s			1	1	1	1	1	1	1	0	1	1s			1	1	1	1	1	1	1	1	1	n
1	1	1s			1	1	1	1	1	1	0	1	1	1s			1	1	1	1	1	1	1	1	1	n+1
1	1	1s			1	1	1	1	1	0	1	1	1	1s			1	1	1	1	1	1	1	1	1	n+2
1	1	1s			1	1	1	1	0	1	1	1	1	1s			1	1	1	1	1	1	1	1	1	n+3
1	1	1s			1	1	1	1	0	1	1	1	1	1s			1	1	1	1	1	1	1	1	1	n+4
::																										
1	0	1s			1	1	1	1	1	1	1	1	1	1s			1	1	1	1	1	1	1	1	1	2n-1
0	1	1s			1	1	1	1	1	1	1	1	1	1s			1	1	1	1	1	1	1	1	1	2n

7.1.3.13.2.1.3 Error Forcing Mode

In error forcing mode, a test pattern is applied to the CPU / VIM related inputs of the CCM-R5F compare logic to force an error in the compare error output signal of the compare unit. Depending if error forcing mode is applied to the CPU Output Compare Diagnostic or VIM Output Compare Diagnostic, the ESM error flag “CCM-R5F - CPU compare” or “CCM-R5F - VIM compare” is expected after the error forcing mode completes. As a side effect, the “CCM-R5F self-test error” flag is also asserted whenever the CPU compare error is asserted.

Error forcing mode is similar to the Compare Mismatch Test operation of self-test mode in which an un-equal vector is applied to the CCM-R5F CPU signal ports. The error forcing mode forces the compare mismatch to actually assert the compare error output signal. This ensures that a fault in the path between CCM-R5F and ESM is detected.

Only one hardcoded test pattern is applied into CCM-R5F during error forcing mode. A repeated 0x5 pattern is applied to CPU1 / VIM1 signal port of CCM-R5F input while a repeated 0xA pattern is applied to the CPU2 / VIM2 signal port of CCM-R5F input. The error forcing mode takes one cycle to complete. Hence, the failing signature is presented for one clock cycle. After that, the mode is automatically switched to lockstep mode. The key register (MKEY1 for CPU output compare and MKEY2 for VIM output compare) will indicate the lockstep key mode once it is switched to lockstep mode. During the one cycle required by the error forcing test, the CPU / VIM output signals are not compared. The user should expect the ESM to trigger a response (report the CCM-R5F fail). If no error is detected by the ESM, then a hardware fault is present.

7.1.3.13.2.1.4 Self-Test Error Forcing Mode

In self-test error forcing mode, an error is forced at the self-test error signal. The compare unit is still running in lockstep mode and the key is switched to lockstep after one clock cycle. The ESM error flag “CCM-R5F - self-test” is expected after the self-test error forcing mode completes. Once the expected errors are seen, the application can clean the error through the ESM module.

Table 7-16 shows what error signals and flags are asserted in different operating mode. The behavior of different modes in this table for CPU compare is also valid for other diagnostics such as VIM compare and Checker CPU Inactivity Monitor.

Table 7-16. Error Flags and Error Signals Generation in Each Mode

Mode	Key	Self Test Error Signal	Compare Error Signal	CMPE	STC	STET	STE
Active Compare Lockstep	0000	Enabled	Enabled	Enabled	Disabled	Disabled	Disabled
Self-Test	0110	Enabled	Disabled	Disabled	Enabled	Enabled	Enabled
Error Forcing	1001	Error	Error	Disabled	Disabled	Disabled	Disabled
Self-Test Error Forcing	1111	Error	Enabled	Enabled	Disabled	Disabled	Disabled

7.1.3.13.2.2 CPU Input Inversion Diagnostic

There is another way to intentionally create a mismatch between the two CPUs' outputs as a diagnostic test to self-test the CCM-R5F's CPU Output Compare Diagnostic block. Before the CPU1's outputs are taken to the CCM-R5F, eight of the output signals are first exclusive-ORed bitwise with the 8-bit POLARITYINVERT register. After reset, the default value of the POLARITYINVERT register is all zeros. The resultant values of the 8 signals after the XOR logic with the POLARITYINVERT register will still be the same as the original 8 signal values. However, by programming the POLARITYINVERT to a non-zero values it will have the effect to invert the signal values. This intentional inversion on the inputs to the CCM-R5F will cause the CPU Output Compare Diagnostic to detect a compare error. See Figure 7-7 for illustration.

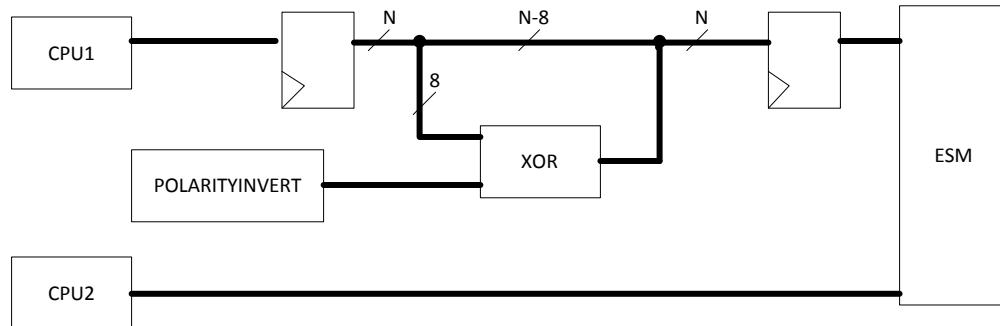

Figure 7-7. CPU Input Inversion Scheme

Table 7-17. CPU1 (Main CPU) Signals Being Inverted Before Being Compared

Signals	Remark
AWVALIDM	Indicates write address and control are valid
ARVALIDM	Indicates write address and control are valid
AWVALIDP	Indicates write address and control are valid
ARVALIDP	Indicates write address and control are valid
HTRANSP[1:0]	Indicates write address and control are valid

7.1.3.13.2.3 Checker CPU Inactivity Monitor

Similar to the CPU / VIM Output Compare Diagnostic, the Checker CPU Inactivity Monitor can also run in one of the following four operating modes:

1. Active compare
2. Self-test
3. Error forcing
4. Self-test error forcing

The operating mode can be selected by writing a dedicated key to the key register (MKEY3).

7.1.3.13.2.3.1 Active Compare Mode

This is the default mode on start-up. In this mode, several key bus signals such as the bus valid control signals from the checker CPU that would have indicated a valid bus transaction onto the interconnect are compared against their clamped safe values. While the two CPUs are in lockstep configuration, the outputs of the checker CPU are supposed to clamp to the inactive state that is all zeros. A difference between the checker CPU compare bus outputs and their respective inactive states is indicated by signaling an error to the ESM which sets the error flag "CCM-R5F - CPU1 AXIM Bus Monitor Failure".

Table 7-18. Checker CPU Signals to Monitor

Signals	Remark
AWVALIDM	When asserted, indicates address and control are valid on the Checker CPU's AXI master port for write transaction.
ARVALIDM	When asserted, indicates address and control are valid on the Checker CPU's AXI master port for read transaction.
AWVALIDP	When asserted, indicates address and control are valid on the Checker CPU's AXI peripheral port for write transaction.
ARVALIDP	When asserted, indicates address and control are valid on the Checker CPU's AXI peripheral port for read transaction.
BVALIDS	When asserted, indicates that a valid write response is available on the Checker CPU's AXI slave port for write transaction
RVALIDS	When asserted, indicates address and control are valid on the Checker CPU's AXI slave port for read transaction

7.1.3.13.2.3.2 Self-Test Mode

Similar to the other self-test described for CPU / VIM Output Compare Diagnostic, the Checker CPU Inactivity Monitor can be placed in self-test mode. In self-test mode, the CCM-R5F checks the Checker CPU Inactivity Monitor itself for faults. During self-test, the compare error module output signal is deactivated. Any fault detected inside the CCM-R5F will be flagged by ESM error "CCM-R5F - self-test".

In self-test mode, the CCM-R5F automatically generates test patterns to look for any hardware faults. If a fault is detected, then a self-test error flag is set, a self-test error signal is asserted and sent to the ESM, and the self-test is terminated immediately. If no fault is found during self-test, the self-test complete flag is set. In both cases, the CCM-R5F Checker CPU Inactivity Monitor Diagnostic remains in self-test mode after the test has been terminated or completed, and the application needs to switch the CCM-R5F mode by writing another key to the mode key register (MKEY3). During the self-test operation, the compare error signal output to the ESM is inactive irrespective of the compare result.

There are also two types of patterns generated by CCM-R5F during self-test mode for Check CPU Inactivity Monitor. The difference here is the number of test patterns applied during self-test.

1. Compare Match Test
2. Compare Mismatch Test

CCM-R5F first generates Compare Match Test patterns, followed by Compare Mismatch Test patterns.

7.1.3.13.2.3.2.1 Compare Match Test

Since the comparison is done against the clamped values, and all compared signals are clamped to zero, only one test pattern is applied for the compare match test. A pattern of all-zeros are applied for the compare match test. The test will take one cycle. If the compare unit produces a compare mismatch then the self-test error flag is set, the self-test error signal is generated, and the Compare Match Test is terminated.

7.1.3.13.2.3.2.2 Compare Mismatch Test

During the Compare Mismatch Test, the number of test patterns is equal to the number of bus signals on the checker CPU to be monitored. There are a total of 6 signals being monitored on the checker CPU's level 2 interface and hence it takes 6 test patterns for the mismatch test. The mismatch test will take a total of 6 cycles to complete. An all 0's test vector is applied to the CCM-R5F's but with one bit flipped starting from signal position 0. The un-equal vector will cause the CCM-R5F to expect a compare mismatch at signal position 0, if the CCM-R5F logic is working correctly. If, however, the CCM-R5F logic reports a compare match, the self-test error flag is set, the self-test error signal is asserted, and the Compare Mismatch Test is terminated.

This Compare Mismatch Test algorithm repeats in a domino fashion with the next signal position flipped while forcing all other signals to logic level 0. This sequence is repeated until every inactivity monitor signal position is verified on the checker CPU .

Table 7-19 shows the sequence of Compare Mismatch Test. There is no error signal sent to ESM if the expected errors are seen with each pattern.

Table 7-19. Checker CPU Inactivity Monitor Compare Mismatch Test

Signal Position						
5	4	3	2	1	0	Cycle
0	0	0	0	0	1	0
0	0	0	0	1	0	1
0	0	0	1	0	0	2
0	0	1	0	0	0	3
0	1	0	0	0	0	4
1	0	0	0	0	0	5

7.1.3.13.2.3.3 Error Forcing Mode

In error forcing mode, a test pattern of all 1's is applied to the check CPU's compare logic to force an error in the compare error output signal of the compare unit. The ESM error flag "CCM-R5F - CPU1 AXIM Bus Inactivity failure" is expected after the error forcing mode completes. As a side effect, the "CCM-R5F self-test error" flag is also asserted whenever the CPU compare error is asserted.

The error forcing mode takes one cycle to complete. Hence, the failing signature is presented for one clock cycle. After that, the mode is automatically switched to active compare mode. The key register (MKEY3) will indicate the active compare mode once it is switched to active compare mode. During the one cycle required by the error forcing test, the checker CPU Inactivity Monitor is deactivated. User should expect the ESM to trigger a response (report the CCM-R5F fail). If no error is detected by ESM, then a hardware fault is present.

7.1.3.13.2.3.4 Self-Test Error Forcing Mode

In self-test error forcing mode, an error is forced at the self-test error signal. The compare unit is still running in active compare mode and the key is switched to active compare after one clock cycle. The ESM error flag "CCM-R5F - self-test" is expected after the self-test error forcing mode completes. Once the expected errors are seen, the application can clean the error through the ESM module.

7.1.3.13.2.4 Operation During CPU Debug Mode

Certain debug operations place the CPU in a halting debug state where the code execution is halted. Because halting debug events are asynchronous, there is a possibility for the debug requests to cause loss of lockstep.

CCM-R5F will disable all functional diagnostics upon detection of halting debug requests. Core compare error will not be generated and flags will not update. A CPU reset is needed to ensure the CPUs are again in lockstep and will also re-enable the CCM-R5F.

7.1.3.13.3 Control Registers

Table 7-20 lists the CCM-R5F registers. Each register begins on a 32-bit word boundary. The registers support 32-bit, 16-bit, and 8-bit accesses. The base address for the control registers is FFFF F600h.

Table 7-20. Control Registers

Offset	Acronym	Register Description	Section
00h	CCMSR1	CCM-R5F Status Register 1	Section 7.1.3.13.3.1
04h	CCMKEYR1	CCM-R5F Key Register 1	Section 7.1.3.13.3.2
08h	CCMSR2	CCM-R5F Status Register 2	Section 7.1.3.13.3.3
0Ch	CCMKEYR2	CCM-R5F Key Register 2	Section 7.1.3.13.3.4
10h	CCMSR3	CCM-R5F Status Register 3	Section 7.1.3.13.3.5
14h	CCMKEYR3	CCM-R5F Key Register 3	Section 7.1.3.13.3.6
18h	CCMPOLCNTRL	Polarity Control Register	Section 7.1.3.13.3.7

7.1.3.13.3.1 CCM-R5F Status Register 1 (CCMSR1)

The contents of this register should be interpreted in context of what test was selected. That is, what mode is CCM operating.

Figure 7-8. CCM-R5F Status Register 1 (CCMSR1) (Offset = 00h)

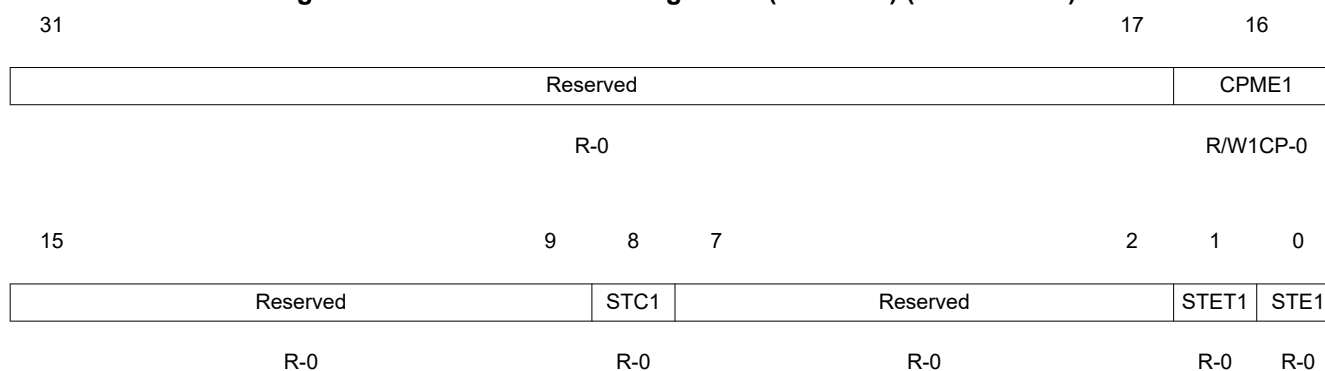

LEGEND: R/W = Read/Write; R = Read only; W1CP = Write 1 to clear in privilege mode only; -n = value after reset

Table 7-21. CCM-R5F Status Register 1 (CCMSR1) Field Descriptions

Bit	Field	Value	Description
31-17	Reserved	0	Reads return 0. Writes have no effect.
16	CMPE1	0	Compare Error for CPU Output Compare Diagnostic. Read in User and Privileged mode. Write in Privileged mode only. Read: CPU signals are identical. Write: Leaves the bit unchanged.
		1	Read: CPU signal compare mismatch. Write: Clears the bit.
15-9	Reserved		Reads return 0. Writes have no effect.

Table 7-21. CCM-R5F Status Register 1 (CCMSR1) Field Descriptions (continued)

Bit	Field	Value	Description
8	STC1	0	Self-test Complete for CPU Output Compare Diagnostic. Note: This bit is always 0 when not in self-test mode. Once set, switching from self-test mode to other modes will clear this bit. Read/Write in User and Privileged mode. Read: Self-test on-going if self-test mode is entered. Write: Writes have no effect.
		1	Read: Self-test is complete. Write: Writes have no effect.
7-2	Reserved		Reads return 0. Writes have no effect.
1	STET1	0	Self-test Error Type for CPU Output Compare Diagnostic. Read/Write in User and Privileged mode. Read: Self-test failed during Compare Match Test if STE1 = 1. Write: Writes have no effect.
		1	Read: Self-test failed during Compare Mismatch Test if STE1 = 1. Write: Writes have no effect.
0	STE1	0	Self-test Error for CPU Output Compare Diagnostic. Note: This bit gets updated when the self-test is complete or an error is detected. Read/Write in User and Privileged mode. Read: Self-test passed. Write: Writes have no effect.
		1	Read: Self-test failed. Write: Writes have no effect.

7.1.3.13.3.2 CCM-R5F Key Register 1 (CCMKEYR1)

Figure 7-9. CCM-R5F Key Register 1 (CCMKEYR1) (Offset = 04h)

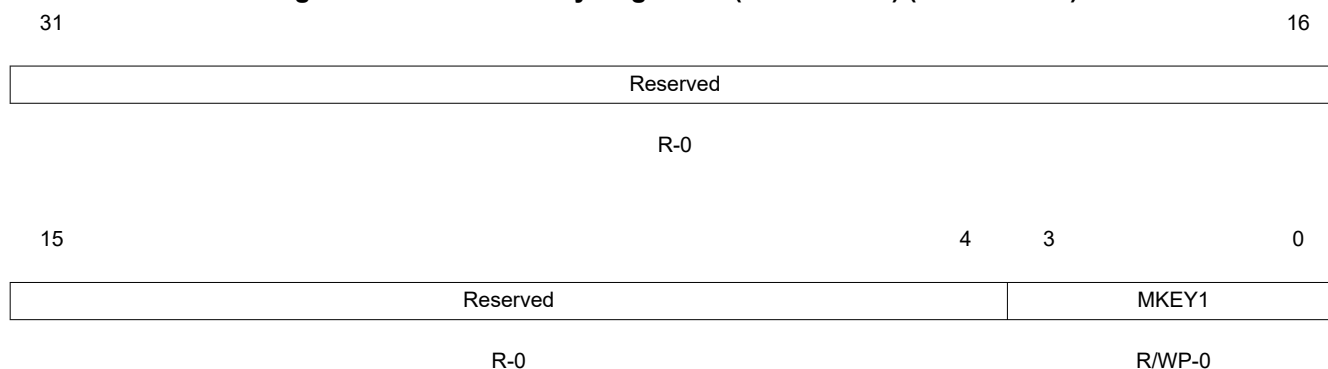

LEGEND: R/W = Read/Write; R = Read only; WP = Write in privileged mode only; -n = value after reset

Table 7-22. CCM-R5F Key Register 1 (CCMKEYR1) Field Descriptions

Bit	Field	Value	Description
31-4	Reserved	0	Reads return 0. Writes have no effect.
3-0	MKEY1	0	Mode Key to select operation for CPU Output Compare Diagnostic . Read in User and Privileged mode. Write in Privileged mode only. Read: Returns current value of the MKEY1. Write: Active Compare Lockstep mode.
		6h	Read: Returns current value of the MKEY1. Write: Self-test mode.
		9h	Read: Returns current value of the MKEY1. Write: Error Forcing mode.
		Fh	Read: Returns current value of the MKEY1. Write: Self-test Error Forcing mode.
		Other values	Note: It is recommended to not write any other key combinations. Invalid keys will result in switching operation to lockstep mode.

7.1.3.13.3.3 CCM-R5F Status Register 2 (CCMSR2)

Figure 7-10. CCM-R5F Status Register 2 (CCMSR2) (Offset = 08h)

31											17	16
Reserved											CPME2	
R-0											R/W1CP-0	
15				9	8	7				2	1	0
Reserved				STC2	Reserved				STET2	STE2		
R-0				R-0	R-0				R-0	R-0		

LEGEND: R/W = Read/Write; R = Read only; W1CP = Write 1 to clear in privilege mode only; -n = value after reset

Table 7-23. CCM-R5F Status Register 2 (CCMSR2) Field Descriptions

Bit	Field	Value	Description
31-17	Reserved	0	Reads return 0. Writes have no effect.
16	CMPE2	0	Compare Error for VIM Output Compare Diagnostic. Read in User and Privileged mode. Write in Privileged mode only. Read: CPU signals are identical. Write: Leaves the bit unchanged.
		1	Read: CPU signal compare mismatch. Write: Clears the bit.
15-9	Reserved		Reads return 0. Writes have no effect.
8	STC2	0	Self-test Complete for VIM Output Compare Diagnostic. Note: This bit is always 0 when not in self-test mode. Once set, switching from self-test mode to other modes will clear this bit. Read/Write in User and Privileged mode. Read: Self-test on-going if self-test mode is entered. Write: Writes have no effect.
		1	Read: Self-test is complete. Write: Writes have no effect.
7-2	Reserved		Reads return 0. Writes have no effect.
1	STET2	0	Self-test Error Type for VIM Output Compare Diagnostic. Read/Write in User and Privileged mode. Read: Self-test failed during Compare Match Test if STE2 = 1. Write: Writes have no effect.
		1	Read: Self-test failed during Compare Mismatch Test if STE2 = 1. Write: Writes have no effect.
0	STE2	0	Self-test Error for VIM Output Compare Diagnostic. Note: This bit gets updated when the self-test is complete or an error is detected. Read/Write in User and Privileged mode. Read: Self-test passed. Write: Writes have no effect.
		1	Read: Self-test failed. Write: Writes have no effect.

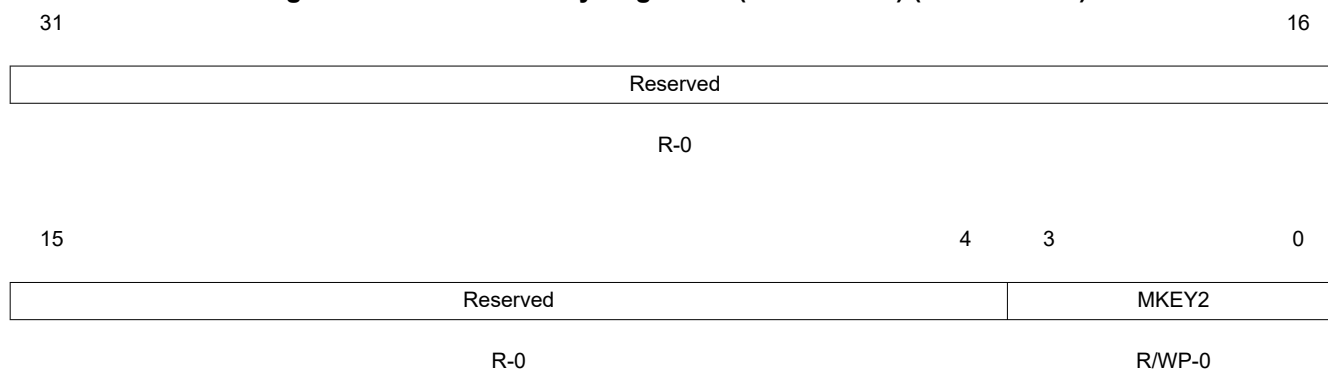
7.1.3.13.3.4 CCM-R5F Key Register 2 (CCMKEYR2)
Figure 7-11. CCM-R5F Key Register 2 (CCMKEYR2) (Offset = 0Ch)

LEGEND: R/W = Read/Write; R = Read only; WP = Write in privileged mode only; -n = value after reset

Table 7-24. CCM-R5F Key Register 2 (CCMKEYR2) Field Descriptions

Bit	Field	Value	Description
31-4	Reserved	0	Reads return 0. Writes have no effect.
3-0	MKEY2	0	Mode Key to select operation for VIM Output Compare Diagnostic. Read in User and Privileged mode. Write in Privileged mode only. Read: Returns current value of the MKEY2. Write: Active Compare Lockstep mode.
		6h	Read: Returns current value of the MKEY2. Write: Self-test mode.
		9h	Read: Returns current value of the MKEY2. Write: Error Forcing mode.
		Fh	Read: Returns current value of the MKEY2. Write: Self-test Error Forcing mode.
		Other values	Note: It is recommended to not write any other key combinations. Invalid keys will result in switching operation to lockstep mode.

7.1.3.13.3.5 CCM-R5F Status Register 3 (CCMSR3)
Figure 7-12. CCM-R5F Status Register 3 (CCMSR3) (Offset = 10h)

31											17	16
Reserved											CPME3	
R-0											R/W1CP-0	
15				9	8	7				2	1	0
Reserved				STC3		Reserved				STET3	STE3	
R-0				R-0		R-0				R-0	R-0	

LEGEND: R/W = Read/Write; R = Read only; W1CP = Write 1 to clear in privilege mode only; -n = value after reset

Table 7-25. CCM-R5F Status Register 3 (CCMSR3) Field Descriptions

Bit	Field	Value	Description
31-17	Reserved	0	Reads return 0. Writes have no effect.
16	CMPE3	0	Compare Error for Checker CPU Inactivity Monitor. Read in User and Privileged mode. Write in Privileged mode only. Read: CPU signals are identical. Write: Leaves the bit unchanged.
		1	Read: CPU signal compare mismatch. Write: Clears the bit.
15-9	Reserved		Reads return 0. Writes have no effect.
8	STC3	0	Self-test Complete for Checker CPU Inactivity Monitor. Note: This bit is always 0 when not in self-test mode. Once set, switching from self-test mode to other modes will clear this bit. Read/Write in User and Privileged mode. Read: Self-test on-going if self-test mode is entered. Write: Writes have no effect.
		1	Read: Self-test is complete. Write: Writes have no effect.
7-2	Reserved		Reads return 0. Writes have no effect.
1	STET3	0	Self-test Error Type for Checker CPU Inactivity Monitor. Read/Write in User and Privileged mode. Read: Self-test failed during Compare Match Test if STE3 = 1. Write: Writes have no effect.
		1	Read: Self-test failed during Compare Mismatch Test if STE3 = 1. Write: Writes have no effect.
0	STE3	0	Self-test Error for Checker CPU Inactivity Monitor. Note: This bit gets updated when the self-test is complete or an error is detected. Read/Write in User and Privileged mode. Read: Self-test passed. Write: Writes have no effect.
		1	Read: Self-test failed. Write: Writes have no effect.

7.1.3.13.3.6 CCM-R5F Key Register 3 (CCMKEYR3)

Figure 7-13. CCM-R5F Key Register 3 (CCMKEYR3) (Offset = 14h)

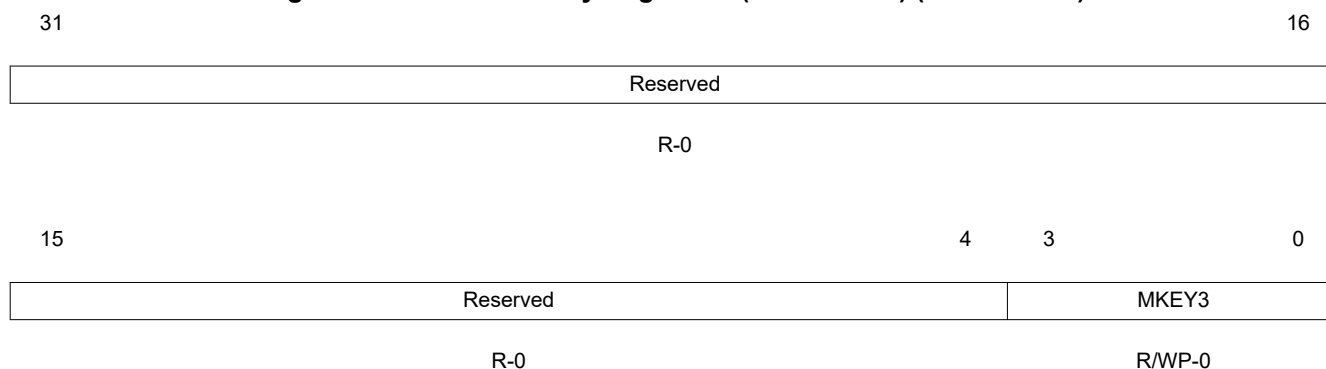

LEGEND: R/W = Read/Write; R = Read only; WP = Write in privileged mode only; -n = value after reset

Table 7-26. CCM-R5F Key Register 2 (CCMKEYR2) Field Descriptions

Bit	Field	Value	Description
31-4	Reserved	0	Reads return 0. Writes have no effect.
3-0	MKEY3	0	Mode Key to select operation for Checker CPU Inactivity Monitor. Read in User and Privileged mode. Write in Privileged mode only. Read: Returns current value of the MKEY3. Write: Active Compare Lockstep mode.
		6h	Read: Returns current value of the MKEY3. Write: Self-test mode.
		9h	Read: Returns current value of the MKEY3. Write: Error Forcing mode.
		Fh	Read: Returns current value of the MKEY3. Write: Self-test Error Forcing mode.
		Other values	Note: It is recommended to not write any other key combinations. Invalid keys will result in switching operation to lockstep mode.

7.1.3.13.3.7 CCM-R5F Polarity Control Register (CCMPOLCNTRL)

Figure 7-14. CCM-R5F Polarity Control Register (CCMPOLCNTRL) (Offset = 18h)

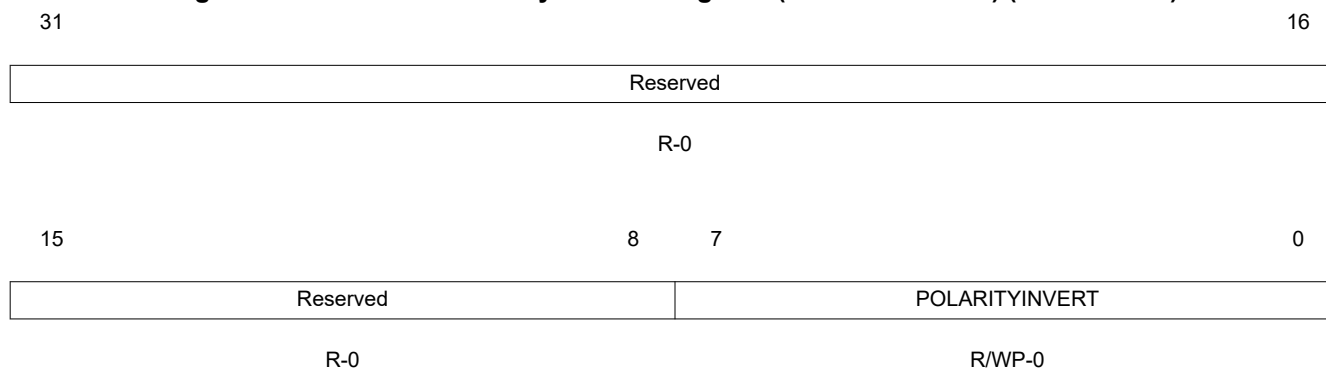

LEGEND: R/W = Read/Write; R = Read only; WP = Write in privileged mode only; -n = value after reset

Table 7-27. CCM-R5F Polarity Control Register (CCMPOLCNTRL) Field Descriptions

Bit	Field	Value	Description
31-8	Reserved	0	Reads return 0. Writes have no effect.
3-0	POLARITYINVERT		Polarity Inversion. This value is used to invert one of the 8 output compare signals from the CPU1 to the CCM-R5F. Inverting any one signal will lead to compare error by the CPU Output Compare Diagnostic. Read in User and Privileged mode. Write in Privileged mode only.

7.1.3.13 R5FSS Selftest Logic

TBD

Note

This content is currently **under-construction** and subject to change prior to official device release.

7.2 Programmable Real-Time Unit Subsystem (PRU-ICSS)

This section describes the Programmable Real-Time Unit Subsystem in the device.

Note

The supported set of features and peripherals is device part number dependent. For more information, see the device datasheet.

Note

The PRU Subsystem (PRUSS) is a subset of the PRU Industrial Communication Subsystem (PRU-ICSS) found on other TI processors. The superset names "PRU-ICSS", and "ICSSM" are used in some parts of the TRM to refer to the PRU Subsystem. Reference the PRU-ICSS Module Integration section for information about PRU-ICSS features that are unsupported in PRU-ICSS.

Note

This content is currently **under-construction** and subject to change prior to official device release.

.....	276
7.2.1 PRU-ICSS Overview	277
7.2.2 PRU-ICSS Environment	280
7.2.3 PRU-ICSS Integration	286
7.2.4 PRU-ICSS Top Level Resources Functional Description	291
7.2.5 PRU-ICSS PRU Cores	297
7.2.6 PRU-ICSS Broadside Accelerators	328
7.2.7 PRU-ICSS Local INTC	340
7.2.8 PRU-ICSS UART Module	346
7.2.9 PRU-ICSS ECAP Module	360
7.2.10 PRU-ICSS MII_RT Module	361
7.2.11 PRU-ICSS MII MDIO Module	384
7.2.12 PRU-ICSS IEP	391

7.2.1 PRU-ICSS Overview

The Programmable Real-Time Unit Subsystem (PRU-ICSS) consists of:

- Two 32-bit load/store RISC CPU cores — Programmable Real-Time Units (PRU0 and PRU1)
- Data RAMs per PRU core (DRAM)
- Instruction RAMs per PRU core (IRAM)
- Shared RAM (SRAM)
- Peripheral modules: UART0, ECAP0, IEP0, MDIO
- Interrupt Controller (INTC) per core

The programmable nature of the PRU cores, along with their access to pins, events and all device resources, provides flexibility in implementing fast real-time responses, specialized data handling operations, custom peripheral interfaces, and in offloading tasks from the other processor cores of the device.

The PRU cores are programmed with a small, deterministic instruction set. Each PRU can operate independently or in coordination with each other and can also work in coordination with the device-level host CPU. This interaction between processors is determined by the nature of the firmware loaded into the PRU's instruction memory.

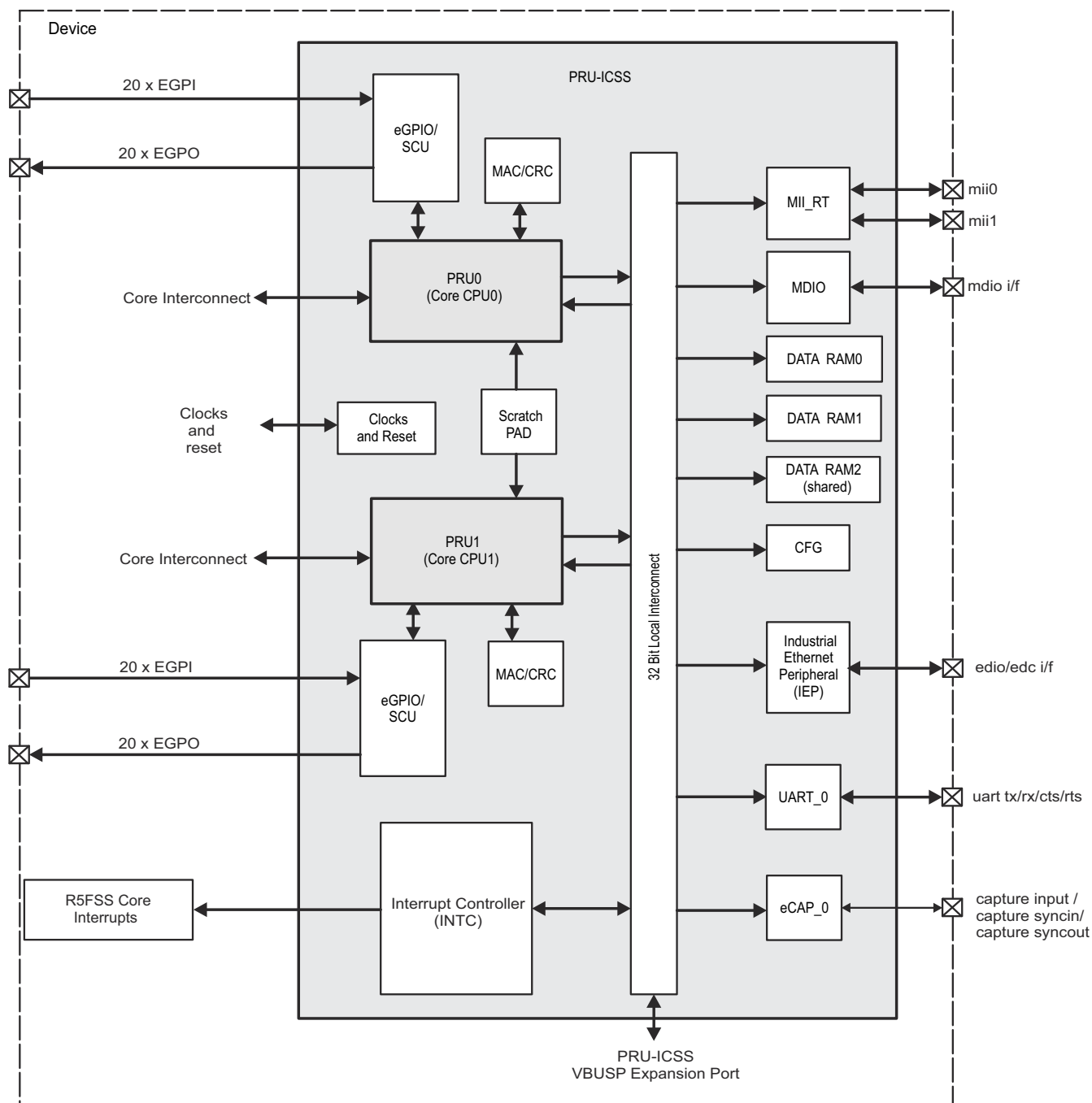

icss-001

Figure 7-15. PRU-ICSS Overview

7.2.1.1 PRU-ICSS Key Features

The PRU-ICSS subsystem includes the following main features:

- Two 32-bit load/store RISC CPU cores — Programmable Real-Time Units (PRU0 and PRU1), each with:
 - 20 Enhanced General-Purpose Inputs (EGPI) and 20 Enhanced General-Purpose Outputs (EGPO)
 - Asynchronous capture [Serial Capture Unit (SCU)] with EnDat 2.2 protocol and Sigma-Delta demodulation support
 - 12KB program memory per PRU (PRU0_IRAM and PRU1_IRAM) with ECC
 - MAC (Multiplier with optional Accumulation)
 - CRC16/CRC32 hardware accelerator

- Broadside (32 Byte) connection to MII_RTn (where n = 1 or 2)
- RX XFR2VBUS
- Scratchpad Memory (SPAD) with 3 banks of 30 × 32-bit registers:
 - 3 banks for the PRU0 and PRU1 cores
- 32 KB Shared general purpose memory RAM with ECC (Data RAM2), shared between PRU0 and PRU1
- Two 8 KB (shared) Data Memories with ECC (Data RAM0 and Data RAM1)
- 36-bit VBUSM Controller Port:
 - Optional address translation for all transactions to External Host
- 16 Software Events generated by 2 PRUs
- Two Real-Time Ethernet ports (MII_RT1 and MII_RT2) configurable to connect to each PRUn (where n = 0 or 1) to support multiple industrial communication protocols.
- One Industrial Ethernet Peripheral's (IEP0) to manage/generate Industrial Ethernet functions such as time stamping.
 - Industrial Ethernet 64-bit timers support 10 capture and 16 compare events along with slow and fast compensation.
- One MDIO port to control external Ethernet PHY
- One Enhanced Capture Module (ECAP0)
- Interrupt Controller (INTC)
 - Up to 32 internal events, generated by modules, internal to the PRU-ICSS
 - Up to 32 external events, generated by the system
 - Supports up to 10 interrupt channels
 - Generation of 8 Host interrupts:
 - 8 Host interrupts, exported from the PRU-ICSS for signaling the Arm interrupt controllers (pulse and level provided)
 - Each system event can be enabled and disabled
 - Each host event can be enabled and disabled
 - Hardware prioritization of events
- One 32-bit VBUSP target port for memory mapped register and internal memories access
- Flexible power management support
- Integrated 32-bit Interconnect

7.2.1.2 Not Supported Features

The following PRU-ICSS features are not supported:

- Industrial Communications Subsystem features
 - Low power clock enable support
 - EnDAT support for PRU1 GPIO at 200MHz
 - Integrated PWM module

7.2.2 PRU-ICSS Environment

This section describes the PRU-ICSS external connections (environment).

7.2.2.1 PRU-ICSS Internal Pinmux

The PRU-ICSS external interface signals are described in [Table 7-28](#). The PRU-ICSS has a large number of available I/O signals. Most of these are multiplexed with other functional signals at the device level.

The PRU-ICSS also support an internal wrapper multiplexing that expands the device top-level multiplexing. This wrapper multiplexing is controlled by the GPCFGx_REG register (where x = 0 or 1) in the PRU-ICSS CFG register space and allows MII_RT, 3 channel Peripheral Interface (with EnDAT capabilities), and Sigma Delta functionality to be muxed with the PRU GPIO device signals, as shown in [Figure 7-16](#). The PRU-ICSS wrapper multiplexing is described with the device-level signals in [Table 7-28](#). Note that the device top-level muxing has higher priority over the internal PRU-ICSS muxing.

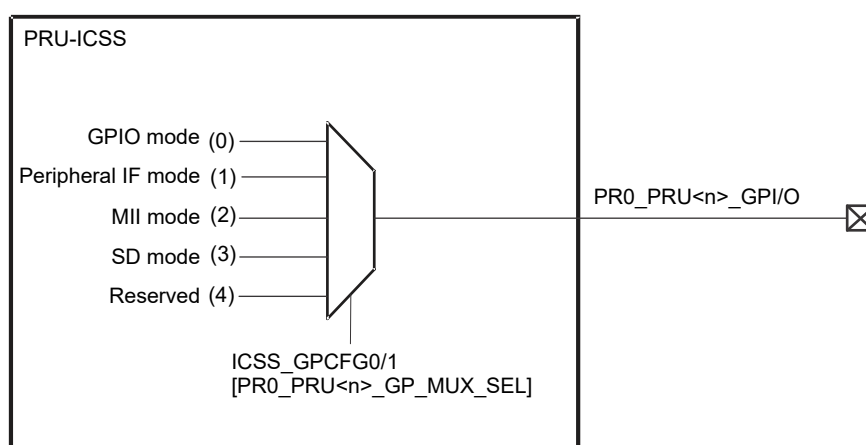

1. n represents a valid instance of PRU in a domain.

Figure 7-16. PRU-ICSS Internal Wrapper Multiplexing

Note

Additionally to PRU-ICSS wrapper multiplexing the device I/O logic maps the PRU-ICSS signals to the different device pins by programming the associated IOMUX CTRLMMR register.

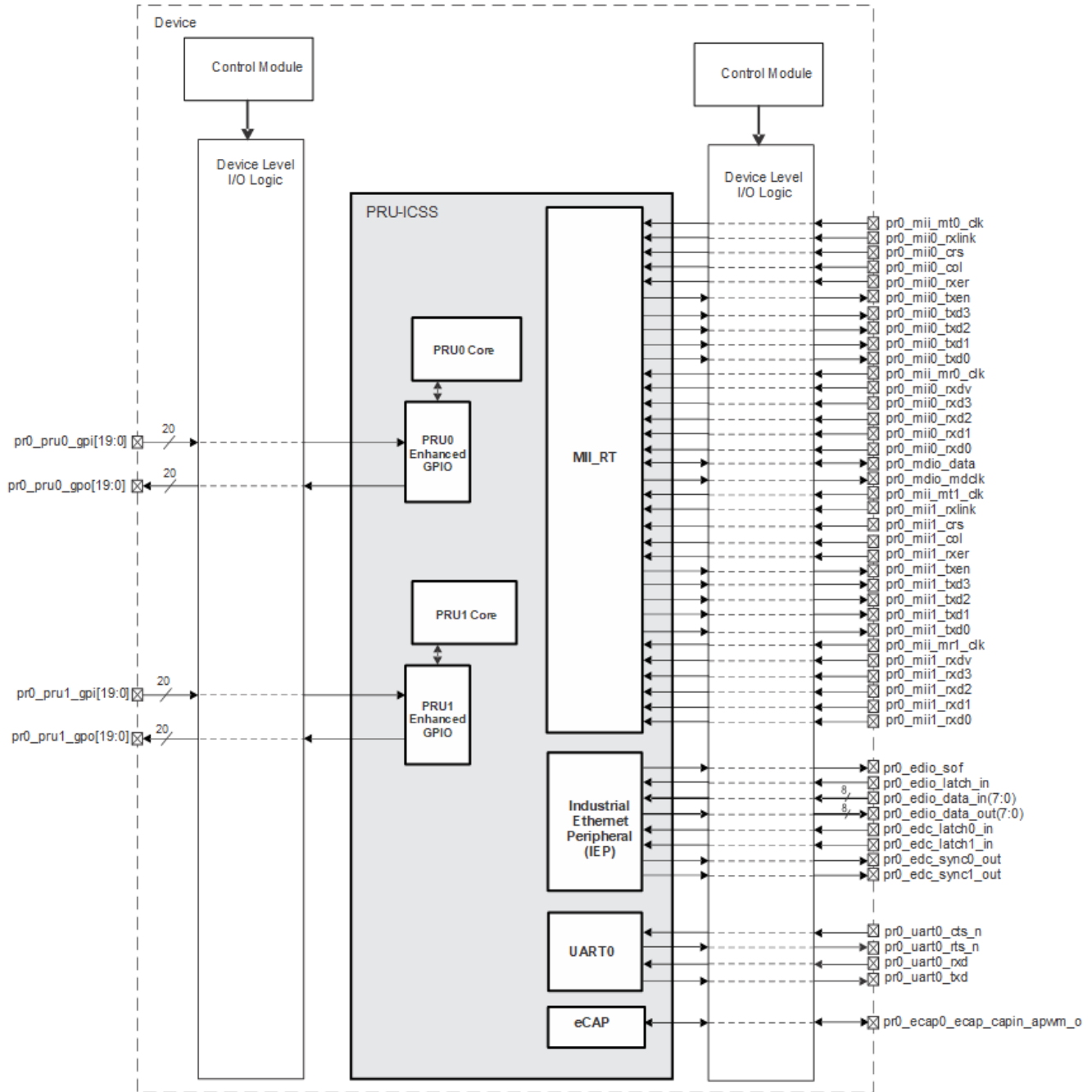

Figure 7-17. PRU-ICSS External Interface I/Os

PRU-ICSS I/O Signals

Table 7-28 describes the PRU-ICSS<k> I/O signals.

Note

<k> is the number of PRU-ICSS in the device. See the Data sheet for additional details.

ADVANCE INFORMATION

Table 7-28. PRU-ICSS I/O Signals

Device Level Signal	Alternate Function via Internal Multiplexing				I/O ⁽¹⁾	Description	Pin Reset ⁽²⁾
	ICSS_GPCCFG0_REG[29-26] PR<k>_PRU0_GP_MUX_SEL=						
PRU0 GP Signals	0h - GPIO mode (default)	1h - PERIF mode	2h - MII mode	3h - SD mode			
PR0_PRU0_GPO0	pr<k>_pru0_pru_r30_ou t[0]	pr<k>_pru0_perif0_cl k			O	PRU0 R30 Outputs	0
PR0_PRU0_GPO1	pr<k>_pru0_pru_r30_ou t[1]	pr<k>_pru0_perif0_o ut		pr<k>_pru0_pru_r30_ out[1]	O	PRU0 R30 Outputs	0
PR0_PRU0_GPO2	pr<k>_pru0_pru_r30_ou t[2]	pr<k>_pru0_perif0_o ut_en			O	PRU0 R30 Outputs	0
PR0_PRU0_GPO3	pr<k>_pru0_pru_r30_ou t[3]	pr<k>_pru0_perif1_cl k			O	PRU0 R30 Outputs	0
PR0_PRU0_GPO4	pr<k>_pru0_pru_r30_ou t[4]	pr<k>_pru0_perif1_o ut			O	PRU0 R30 Outputs	0
PR0_PRU0_GPO5	pr<k>_pru0_pru_r30_ou t[5]	pr<k>_pru0_perif1_o ut_en			O	PRU0 R30 Outputs	0
PR0_PRU0_GPO6	pr<k>_pru0_pru_r30_ou t[6]	pr<k>_pru0_perif2_cl k			O	PRU0 R30 Outputs	0
PR0_PRU0_GPO7	pr<k>_pru0_pru_r30_ou t[7]	pr<k>_pru0_perif2_o ut			O	PRU0 R30 Outputs	0
PR0_PRU0_GPO8	pr<k>_pru0_pru_r30_ou t[8]	pr<k>_pru0_perif2_o ut_en			O	PRU0 R30 Outputs	0
PR0_PRU0_GPO9	pr<k>_pru0_pru_r30_ou t[9]				O	PRU0 R30 Outputs	0
PR0_PRU0_GPO10	pr<k>_pru0_pru_r30_ou t[10]				O	PRU0 R30 Outputs	0
PR0_PRU0_GPO11	pr<k>_pru0_pru_r30_ou t[11]		pr<k>_mii1_txd[0]		O	PRU0 R30 Outputs	0
PR0_PRU0_GPO12	pr<k>_pru0_pru_r30_ou t[12]		pr<k>_mii1_txd[1]		O	PRU0 R30 Outputs	0
PR0_PRU0_GPO13	pr<k>_pru0_pru_r30_ou t[13]		pr<k>_mii1_txd[2]		O	PRU0 R30 Outputs	0
PR0_PRU0_GPO14	pr<k>_pru0_pru_r30_ou t[14]		pr<k>_mii1_txd[3]		O	PRU0 R30 Outputs	0
PR0_PRU0_GPO15	pr<k>_pru0_pru_r30_ou t[15]		pr<k>_mii1_txen		O	PRU0 R30 Outputs	0
PR0_PRU0_GPO16	pr<k>_pru0_pru_r30_ou t[16]				O	PRU0 R30 Outputs	0
PR0_PRU0_GPO17	pr<k>_pru0_pru_r30_ou t[17]				O	PRU0 R30 Outputs	0
PR0_PRU0_GPO18	pr<k>_pru0_pru_r30_ou t[18]				O	PRU0 R30 Outputs	0
PR0_PRU0_GPO19	pr<k>_pru0_pru_r30_ou t[19]				O	PRU0 R30 Outputs	0
PR0_PRU0_GPI0	pr<k>_pru0_pru_r31_in[0]		pr<k>_mii0_rxd[0]	pr<k>_pru0_sd0_clk	I	PRU0 R31 Inputs	HiZ
PR0_PRU0_GPI1	pr<k>_pru0_pru_r31_in[1]		pr<k>_mii0_rxd[1]	pr<k>_pru0_sd0_d	I	PRU0 R31 Inputs	HiZ
PR0_PRU0_GPI2	pr<k>_pru0_pru_r31_in[2]		pr<k>_mii0_rxd[2]	pr<k>_pru0_sd1_clk	I	PRU0 R31 Inputs	HiZ
PR0_PRU0_GPI3	pr<k>_pru0_pru_r31_in[3]		pr<k>_mii0_rxd[3]	pr<k>_pru0_sd1_d	I	PRU0 R31 Inputs	HiZ
PR0_PRU0_GPI4	pr<k>_pru0_pru_r31_in[4]		pr<k>_mii0_rxdv	pr<k>_pru0_sd2_clk	I	PRU0 R31 Inputs	HiZ
PR0_PRU0_GPI5	pr<k>_pru0_pru_r31_in[5]		pr<k>_mii0_rxer	pr<k>_pru0_sd2_d	I	PRU0 R31 Inputs	HiZ
PR0_PRU0_GPI6	pr<k>_pru0_pru_r31_in[6]		pr<k>_mii_mr0_clk	pr<k>_pru0_sd3_clk	I	PRU0 R31 Inputs	HiZ

Table 7-28. PRU-ICSS I/O Signals (continued)

Device Level Signal	Alternate Function via Internal Multiplexing			I/O ⁽¹⁾	Description	Pin Reset ⁽²⁾	
PR0_PRU0_GPI7	pr<k>_pru0_pru_r31_in[7]		pr<k>_pru0_sd3_d	I	PRU0 R31 Inputs	HiZ	
PR0_PRU0_GPI8	pr<k>_pru0_pru_r31_in[8]	pr<k>_mii0_rxlink	pr<k>_pru0_sd4_clk	I	PRU0 R31 Inputs	HiZ	
PR0_PRU0_GPI9	pr<k>_pru0_pru_r31_in[9]	pr<k>_pru0_perif0_in	pr<k>_mii0_col	pr<k>_pru0_sd4_d	I	PRU0 R31 Inputs	HiZ
PR0_PRU0_GPI10	pr<k>_pru0_pru_r31_in[10]	pr<k>_pru0_perif1_in	pr<k>_mii0_crs	pr<k>_pru0_sd5_clk	I	PRU0 R31 Inputs	HiZ
PR0_PRU0_GPI11	pr<k>_pru0_pru_r31_in[11]	pr<k>_pru0_perif2_in		pr<k>_pru0_sd5_d	I	PRU0 R31 Inputs	HiZ
PR0_PRU0_GPI12	pr<k>_pru0_pru_r31_in[12]			pr<k>_pru0_sd6_clk	I	PRU0 R31 Inputs	HiZ
PR0_PRU0_GPI13	pr<k>_pru0_pru_r31_in[13]			pr<k>_pru0_sd6_d	I	PRU0 R31 Inputs	HiZ
PR0_PRU0_GPI14	pr<k>_pru0_pru_r31_in[14]			pr<k>_pru0_sd7_clk	I	PRU0 R31 Inputs	HiZ
PR0_PRU0_GPI15	pr<k>_pru0_pru_r31_in[15]			pr<k>_pru0_sd7_d	I	PRU0 R31 Inputs	HiZ
PR0_PRU0_GPI16	pr<k>_pru0_pru_r31_in[16]	pr<k>_pru0_pru_r31_in[16]	pr<k>_mii_mt1_clk, pr<k>_pru0_pru_r31_in[16]	pr<k>_pru0_sd8_clk, pr<k>_pru0_pru_r31_in[16]	I	PRU0 R31 Inputs	HiZ
PR0_PRU0_GPI17	pr<k>_pru0_pru_r31_in[17]			pr<k>_pru0_sd8_d	I	PRU0 R31 Inputs	HiZ
PR0_PRU0_GPI18	pr<k>_pru0_pru_r31_in[18]				I	PRU0 R31 Inputs	HiZ
PR0_PRU0_GPI19	pr<k>_pru0_pru_r31_in[19]				I	PRU0 R31 Inputs	HiZ
PRU1 GP Signals	ICSS_GPCFG1_REG[29-26] PR0_PRU1_GP_MUX_SEL=						
	0h - GPIO mode (default)	1h - PERIF mode	2h - MII mode	3h - SD mode			
PR0_PRU1_GPO0	pr<k>_pru1_pru_r30_out[0]	pr<k>_pru1_perif0_clk			O	PRU1 R30 Outputs	0
PR0_PRU1_GPO1	pr<k>_pru1_pru_r30_out[1]	pr<k>_pru1_perif0_out		pr<k>_pru1_pru_r30_out[1]	O	PRU1 R30 Outputs	0
PR0_PRU1_GPO2	pr<k>_pru1_pru_r30_out[2]	pr<k>_pru1_perif0_out_en			O	PRU1 R30 Outputs	0
PR0_PRU1_GPO3	pr<k>_pru1_pru_r30_out[3]	pr<k>_pru1_perif1_clk			O	PRU1 R30 Outputs	0
PR0_PRU1_GPO4	pr<k>_pru1_pru_r30_out[4]	pr<k>_pru1_perif1_out			O	PRU1 R30 Outputs	0
PR0_PRU1_GPO5	pr<k>_pru1_pru_r30_out[5]	pr<k>_pru1_perif1_out_en			O	PRU1 R30 Outputs	0
PR0_PRU1_GPO6	pr<k>_pru1_pru_r30_out[6]	pr<k>_pru1_perif2_clk			O	PRU1 R30 Outputs	0
PR0_PRU1_GPO7	pr<k>_pru1_pru_r30_out[7]	pr<k>_pru1_perif2_out			O	PRU1 R30 Outputs	0
PR0_PRU1_GPO8	pr<k>_pru1_pru_r30_out[8]	pr<k>_pru1_perif2_out_en			O	PRU1 R30 Outputs	0
PR0_PRU1_GPO9	pr<k>_pru1_pru_r30_out[9]				O	PRU1 R30 Outputs	0
PR0_PRU1_GPO10	pr<k>_pru1_pru_r30_out[10]				O	PRU1 R30 Outputs	0
PR0_PRU1_GPO11	pr<k>_pru1_pru_r30_out[11]		pr<k>_mii0_txd[0]		O	PRU1 R30 Outputs	0
PR0_PRU1_GPO12	pr<k>_pru1_pru_r30_out[12]		pr<k>_mii0_txd[1]		O	PRU1 R30 Outputs	0
PR0_PRU1_GPO13	pr<k>_pru1_pru_r30_out[13]		pr<k>_mii0_txd[2]		O	PRU1 R30 Outputs	0

Table 7-28. PRU-ICSS I/O Signals (continued)

Device Level Signal	Alternate Function via Internal Multiplexing			I/O ⁽¹⁾	Description	Pin Reset ⁽²⁾
PR0_PRU1_GPO14	pr<k>_pru1_pru_r30_ou t[14]		pr<k>_mii0_txd[3]	O	PRU1 R30 Outputs	0
PR0_PRU1_GPO15	pr<k>_pru1_pru_r30_ou t[15]		pr<k>_mii0_txen	O	PRU1 R30 Outputs	0
PR0_PRU1_GPO16	pr<k>_pru1_pru_r30_ou t[16]			O	PRU1 R30 Outputs	0
PR0_PRU1_GPO17	pr<k>_pru1_pru_r30_ou t[17]			O	PRU1 R30 Outputs	0
PR0_PRU1_GPO18	pr<k>_pru1_pru_r30_ou t[18]			O	PRU1 R30 Outputs	0
PR0_PRU1_GPO19	pr<k>_pru1_pru_r30_ou t[19]			O	PRU1 R30 Outputs	0
PR0_PRU1_GPI0	pr<k>_pru1_pru_r31_in[0]		pr<k>_mii1_rxd[0]	I	PRU1 R31 Inputs	HiZ
PR0_PRU1_GPI1	pr<k>_pru1_pru_r31_in[1]		pr<k>_mii1_rxd[1]	I	PRU1 R31 Inputs	HiZ
PR0_PRU1_GPI2	pr<k>_pru1_pru_r31_in[2]		pr<k>_mii1_rxd[2]	I	PRU1 R31 Inputs	HiZ
PR0_PRU1_GPI3	pr<k>_pru1_pru_r31_in[3]		pr<k>_mii1_rxd[3]	I	PRU1 R31 Inputs	HiZ
PR0_PRU1_GPI4	pr<k>_pru1_pru_r31_in[4]		pr<k>_mii1_rxdv	I	PRU1 R31 Inputs	HiZ
PR0_PRU1_GPI5	pr<k>_pru1_pru_r31_in[5]		pr<k>_mii1_rxer	I	PRU1 R31 Inputs	HiZ
PR0_PRU1_GPI6	pr<k>_pru1_pru_r31_in[6]		pr<k>_mii_mr1_clk	I	PRU1 R31 Inputs	HiZ
PR0_PRU1_GPI7	pr<k>_pru1_pru_r31_in[7]			I	PRU1 R31 Inputs	HiZ
PR0_PRU1_GPI8	pr<k>_pru1_pru_r31_in[8]		pr<k>_mii1_rmlink	I	PRU1 R31 Inputs	HiZ
PR0_PRU1_GPI9	pr<k>_pru1_pru_r31_in[9]	pr<k>_pru1_perif0_in	pr<k>_mii1_col	I	PRU1 R31 Inputs	HiZ
PR0_PRU1_GPI10	pr<k>_pru1_pru_r31_in[10]	pr<k>_pru1_perif1_in	pr<k>_mii1_crs	I	PRU1 R31 Inputs	HiZ
PR0_PRU1_GPI11	pr<k>_pru1_pru_r31_in[11]	pr<k>_pru1_perif2_in		I	PRU1 R31 Inputs	HiZ
PR0_PRU1_GPI12	pr<k>_pru1_pru_r31_in[12]			I	PRU1 R31 Inputs	HiZ
PR0_PRU1_GPI13	pr<k>_pru1_pru_r31_in[13]			I	PRU1 R31 Inputs	HiZ
PR0_PRU1_GPI14	pr<k>_pru1_pru_r31_in[14]			I	PRU1 R31 Inputs	HiZ
PR0_PRU1_GPI15	pr<k>_pru1_pru_r31_in[15]			I	PRU1 R31 Inputs	HiZ
PR0_PRU1_GPI16	pr<k>_pru1_pru_r31_in[16]	pr<k>_pru1_pru_r31_ in[16]	pr<k>_mii_mt0_clk, pr<k>_pru1_pru_r31_ in[16]	I	PRU1 R31 Inputs	HiZ
PR0_PRU1_GPI17	pr<k>_pru1_pru_r31_in[17]			I	PRU1 R31 Inputs	HiZ
PR0_PRU1_GPI18	pr<k>_pru1_pru_r31_in[18]			I	PRU1 R31 Inputs	HiZ
PR0_PRU1_GPI19	pr<k>_pru1_pru_r31_in[19]			I	PRU1 R31 Inputs	HiZ
MDIO	MDIO					
PR0_MDIO0_MDC	pr<k>_mdio_mdclk			O	MDIO Clock	0
PR0_MDIO0_MDIO	pr<k>_mdio_data			I/O	MDIO Data	HiZ
Industrial Ethernet (IEP0)	Industrial Ethernet					

Table 7-28. PRU-ICSS I/O Signals (continued)

Device Level Signal	Alternate Function via Internal Multiplexing	I/O ⁽¹⁾	Description	Pin Reset ⁽²⁾
PR0_IEP0_EDIO_OUTV ALID	pr<k>_iep0_edio_outvali d	O	IEP0 Digital I/O Output Valid	0
PR0_IEP0_EDIO_DATA _IN_OUT[31:28]	pr<k>_iep0_edio_data_i n_out[31:28]	I/O	IEP0 Digital I/Os Data In/Out	HiZ
PR0_IEP0_EDC_SYNC _OUT0	pr<k>_iep0_edc_sync_o ut0	O	IEP0 Distributed Clock Sync Out	0
PR0_IEP0_EDC_SYNC _OUT1	pr<k>_iep0_edc_sync_o ut1	O	IEP0 Distributed Clock Sync Out	0
PR0_IEP0_EDC_LATC H_IN0	pr<k>_iep0_edc_latch_i n0	I	IEP0 Distributed Clock Latch In	HiZ
PR0_IEP0_EDC_LATC H_IN1	pr<k>_iep0_edc_latch_i n1	I	IEP0 Distributed Clock Latch In	HiZ
UART0	UART0			
PR0_UART0_CTSn	pr<k>_uart0_cts_n	I	UART0 Clear to Send	HiZ
PR0_UART0_RTSn	pr<k>_uart0_rts_n	O	UART0 Request to Send	1
PR0_UART0_RXD	pr<k>_uart0_rxd	I	UART0 Receive Data	HiZ
PR0_UART0_TXD	pr<k>_uart0_txd	O	UART0 Transmit Data	1
ECAP0	ECAP0			
PR0_ECAP0_IN_APWM _OUT	pr<k>_ecap0_ecap_capi n_apwm_o	I/O	Enhanced capture (ECAP0) input or Auxiliary PWM out	HiZ
PR0_ECAP0_SYNC_IN	pr<k>_ecap0_ecap_syn cin	I	Enhanced capture (ECAP0) Sync In	0
PR0_ECAP0_SYNC_O UT	pr<k>_ecap0_ecap_syn cout	O	Enhanced capture (ECAP0) Sync Out	0

(1) I = Input; O = Output

(2) HiZ = High Impedance

7.2.2.2 PRU-ICSS Fast GPIO pins

Each PRU-ICSS PRU processor implements fast general purpose outputs (GPO) through its R30 register and fast general purpose inputs (GPI) through its R31 register. The device multiplexes all GPI signals and their corresponding GPO signals onto the same device pin using different device multiplexing modes. In some applications it may be necessary for the PRU to switch between GPO and GPI operation in a fast (or at least a deterministic) manner. This is not possible using SoC level pin muxing since each pin being switched requires a write to a separate pin configuration register located in Control Module (CTRL_MMR0).

In order to address the fast switching issue, special I/O pin connectivity for the PRU-ICSS GPO/GPI pins is implemented. This feature makes use of the IEP EDIO signal controls to provide input/output switching using a single SoC level pin multiplexing mode.

The IEP EDIO interface has 32 data input (DATA_IN) and 32 data output (DATA_OUT) signals. It also has a set of 32 corresponding data output enable (DATA_OUT_EN) signals to be used as (active low) output driver enables to allow each DATA_OUT/DATA_IN to be implemented as a bidirectional pin. On this device, only 4 of the IEP EDIO I/Os of each PRU-ICSS module are pinned out (PRG[2:0]_IEP_EDIO_DATA_IN_OUT[31:28]). This leaves a majority of the DATA_OUT_EN signals unused. The device allows these unused output enables to be optionally re-purposed for use as GPO enables. This allows each PRU-ICSS GP pin to function as either a GPO or as a GPI when the I/O pin is configured for the GPO muxmode.

A set of SoC level registers (CTRLMMR_ICSS[2:0]_CTRL[2:0]) are used to determine the behavior of each GPO mode pin. When a register's [19:0]GPM_BIDI bit field is set to 0h (default value), the corresponding GPO pin operates only as an output when the GPO multiplexing mode is selected and is driven with the R30 bit value. The corresponding GPI signal (PRU-ICSS GPI<n> input, where n = 0 to 19) is driven low. When a register's [19:0]GPM_BIDI bit field is set to 1h, the corresponding ICSS_DIGIO_DATA_OUT_EN_REG[31:0] DATA_OUT_EN bit field is used to control the GPO output buffer. If [31:0] DATA_OUT_EN bit field is set to 0h the output is driven and the pin acts as a GPO. If [31:0] DATA_OUT_EN bit field is set to 1h the output is disabled and the pin acts as a GPI.

The PRU[1:0]_GPM[19:0] output signals are propagated to the PRG_PRU[1:0]_GPO[19:0] pins using Muxmode 0 function and the PRU[1:0]_GPN[19:0] input signals are propagated to the PRG_PRU[1:0]_GPI[19:0] pins using Muxmode 1 function. Any GPO (Muxmode 0 function) can be made bidirectional by setting the corresponding bit field [19:0]GPM_BIDI in CTRLMMR_ICSS_CTRL[2:0] register.

7.2.3 PRU-ICSS Integration

This section describes modules integration in the device, including information about clocks, resets, and hardware requests.

7.2.3.1 PRU-ICSS Integration (AM263x)

There is a singular Industrial Connectivity Subsystem (ICSS) that consists of two Programmable Real-Time Units (PRU) integrated in the device. The diagram below provides a visual representation of the device integration details.

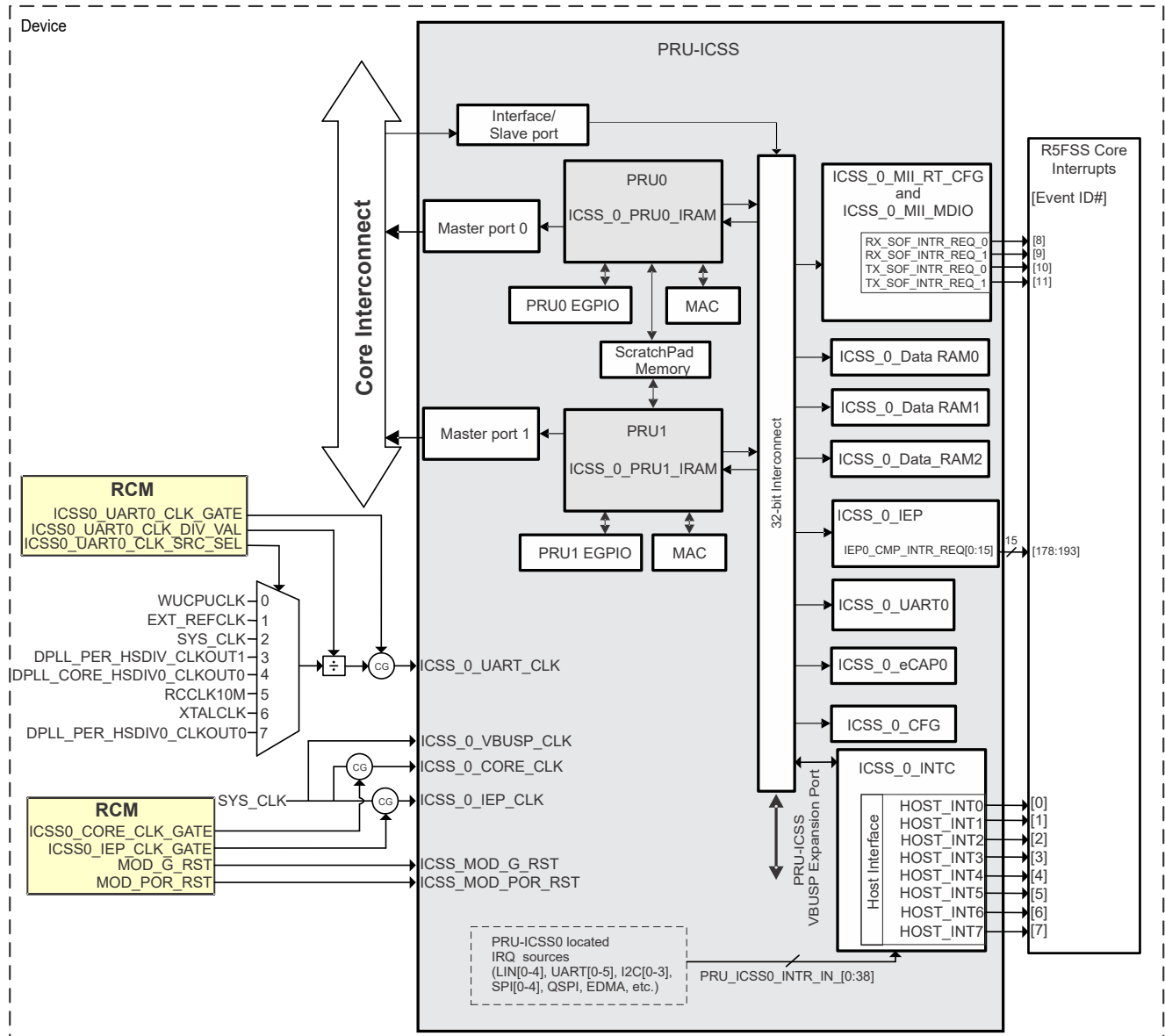

ADVANCE INFORMATION

Figure 7-18. PRU-ICSS Integration Diagram

The tables below summarize the device integration details of PRU-ICSS.

Table 7-29. PRU-ICSS Device Integration

This table describes the module device integration details.

Module Instance	Device Allocation	SoC Interconnect
PRU0	✓	Core Interconnect
PRU1	✓	Core Interconnect

Table 7-30. PRU-ICSS Clocks

This table describes the module clocking signals.

Module Instance	Module Clock Input	Source Clock Signal	Source	Default Freq	Description
ICSS	ICSS_ICLK (VBUSP_CLK)	ICSS_SYS_CLK	PLL_CORE_CLK: HSDIV0_CLKOUT0	200 MHz	ICSS Interface Clock
	ICSS_FCLK (CORE_CLK)	ICSS_CORE_CLK	PLL_CORE_CLK: HSDIV0_CLKOUT0	200 MHz	ICSS Functional Core Clock
	ICSS_UART_CLK (UART_CLK)	WUCPUCLK	External XTAL or RC Oscillator	25 MHz	ICSS Selectable UART Clock
			EXT_REFCLK	External Reference Clock (EXT_REFCLK)	
		SYS_CLK	PLL_CORE_CLK: HSDIV0_CLKOUT0	200 MHz	
		DPLL_PER_HSDIV0_CLK OUT1	PLL_PER_CLK: HSDIV0_CLKOUT1	192 MHz	
		DPLL_CORE_HSDIV0_CL KOUT0	PLL_CORE_CLK: HSDIV0_CLKOUT0	400 MHz	
		RCCLK10M	Internal 10MHz RC Oscillator (RCCLK10M)	10 MHz	
		XTALCLK	External XTAL	25 MHz	
		DPLL_PER_HSDIV0_CLK OUT0	PLL_PER_CLK:HSDIV0_C LKOUT0	160 MHz	
ICSS_IEP_CLK (IEP_CLK)	ICSS_IEP_CLK	PLL_CORE_CLK: HSDIV0_CLKOUT0	200 MHz	ICSS Industrial Ethernet Clock	

Table 7-31. PRU-ICSS Resets

This table describes the module reset signals.

Module Instance	Module Reset Input	Source Reset Signal	Source	Description
ICSS	ICSS_RST (ICSS_WARM_RESET)	Warm Reset (MOD_G_RST)	RCM + Warm Reset Sources	ICSS Warm Reset
	ICSS_RST (ICSS_POR_RESET)	POR (MOD_POR_RST)	RCM + POR Sources	ICSS Power on Reset

Table 7-32. PRU-ICSS Interrupt Requests

This table describes the module interrupt requests.

Module Instance	Module Interrupt Signal	Destination Interrupt Input	Destination	Type	Description
ICSS_INTC	PR1_HOST_INTR_P END_0	R5FSS Interrupt ID [0]	ALL R5FSS Cores	Level	PRU-ICSS Host interrupt 0
	PR1_HOST_INTR_P END_1	R5FSS Interrupt ID [1]	ALL R5FSS Cores	Level	PRU-ICSS Host interrupt 1
	PR1_HOST_INTR_P END_2	R5FSS Interrupt ID [2]	ALL R5FSS Cores	Level	PRU-ICSS Host interrupt 2
	PR1_HOST_INTR_P END_3	R5FSS Interrupt ID [3]	ALL R5FSS Cores	Level	PRU-ICSS Host interrupt 3
	PR1_HOST_INTR_P END_4	R5FSS Interrupt ID [4]	ALL R5FSS Cores	Level	PRU-ICSS Host interrupt 4
	PR1_HOST_INTR_P END_5	R5FSS Interrupt ID [5]	ALL R5FSS Cores	Level	PRU-ICSS Host interrupt 5
	PR1_HOST_INTR_P END_6	R5FSS Interrupt ID [6]	ALL R5FSS Cores	Level	PRU-ICSS Host interrupt 6
	PR1_HOST_INTR_P END_7	R5FSS Interrupt ID [7]	ALL R5FSS Cores	Level	PRU-ICSS Host interrupt 7
ICSS_MII	PR1_RX_SOF_INTR _REQ_0	R5FSS Interrupt ID [8]	ALL R5FSS Cores	Level	PRU-ICSS RX SOF Interrupt Request 0
	PR1_RX_SOF_INTR _REQ_1	R5FSS Interrupt ID [9]	ALL R5FSS Cores	Level	PRU-ICSS RX SOF Interrupt Request 1
	PR1_TX_SOF_INTR _REQ_0	R5FSS Interrupt ID [10]	ALL R5FSS Cores	Level	PRU-ICSS TX SOF Interrupt Request 0
	PR1_TX_SOF_INTR _REQ_1	R5FSS Interrupt ID [11]	ALL R5FSS Cores	Level	PRU-ICSS TX SOF Interrupt Request 1

Table 7-32. PRU-ICSS Interrupt Requests (continued)

This table describes the module interrupt requests.

Module Instance	Module Interrupt Signal	Destination Interrupt Input	Destination	Type	Description
ICSS_IEP	PR1_IEP0_CMP_IN TR_REQ_0	R5FSS Interrupt ID [178]	ALL R5FSS Cores	Level	PRU-ICSS IEP Compare Event Interrupt
	PR1_IEP0_CMP_IN TR_REQ_1	R5FSS Interrupt ID [179]	ALL R5FSS Cores	Level	PRU-ICSS IEP Compare Event Interrupt
	PR1_IEP0_CMP_IN TR_REQ_2	R5FSS Interrupt ID [180]	ALL R5FSS Cores	Level	PRU-ICSS IEP Compare Event Interrupt
	PR1_IEP0_CMP_IN TR_REQ_3	R5FSS Interrupt ID [181]	ALL R5FSS Cores	Level	PRU-ICSS IEP Compare Event Interrupt
	PR1_IEP0_CMP_IN TR_REQ_4	R5FSS Interrupt ID [182]	ALL R5FSS Cores	Level	PRU-ICSS IEP Compare Event Interrupt
	PR1_IEP0_CMP_IN TR_REQ_5	R5FSS Interrupt ID [183]	ALL R5FSS Cores	Level	PRU-ICSS IEP Compare Event Interrupt
	PR1_IEP0_CMP_IN TR_REQ_6	R5FSS Interrupt ID [184]	ALL R5FSS Cores	Level	PRU-ICSS IEP Compare Event Interrupt
	PR1_IEP0_CMP_IN TR_REQ_7	R5FSS Interrupt ID [185]	ALL R5FSS Cores	Level	PRU-ICSS IEP Compare Event Interrupt
	PR1_IEP0_CMP_IN TR_REQ_8	R5FSS Interrupt ID [186]	ALL R5FSS Cores	Level	PRU-ICSS IEP Compare Event Interrupt
	PR1_IEP0_CMP_IN TR_REQ_9	R5FSS Interrupt ID [187]	ALL R5FSS Cores	Level	PRU-ICSS IEP Compare Event Interrupt
	PR1_IEP0_CMP_IN TR_REQ_10	R5FSS Interrupt ID [188]	ALL R5FSS Cores	Level	PRU-ICSS IEP Compare Event Interrupt
	PR1_IEP0_CMP_IN TR_REQ_11	R5FSS Interrupt ID [189]	ALL R5FSS Cores	Level	PRU-ICSS IEP Compare Event Interrupt
	PR1_IEP0_CMP_IN TR_REQ_12	R5FSS Interrupt ID [190]	ALL R5FSS Cores	Level	PRU-ICSS IEP Compare Event Interrupt
	PR1_IEP0_CMP_IN TR_REQ_13	R5FSS Interrupt ID [191]	ALL R5FSS Cores	Level	PRU-ICSS IEP Compare Event Interrupt
	PR1_IEP0_CMP_IN TR_REQ_14	R5FSS Interrupt ID [192]	ALL R5FSS Cores	Level	PRU-ICSS IEP Compare Event Interrupt
PR1_IEP0_CMP_IN TR_REQ_15	R5FSS Interrupt ID [193]	ALL R5FSS Cores	Level	PRU-ICSS IEP Compare Event Interrupt	

Note

For more information on the interconnects, see the *System Interconnect* chapter.

For more information on power, reset, and clock management, see the corresponding sections within the *Device Configuration* chapter.

For more information on the device interrupt controllers, see the *Interrupt Controllers* chapter.

7.2.4 PRU-ICSS Top Level Resources Functional Description

This section provides functional description of the device integrated PRU Subsystems modules.

The PRU_n (where n = 0 or 1) cores within each PRU-ICSS have access to all resources on the SoC through the VBUSM Interface Controller port, and the external host processors can access the PRU-ICSS resources through the VBUSP Interface Target port. The use of XFR2VBUS allows BroadSide 32Bytes of data transfer to/from SoC CBASS0 Interconnect at 256-bit bursts using the VBUSM Controller port. The 32-bit Internal CBASS Interconnect bus will be the primary interconnect between all components internal to the PRU-ICSS. There are two equally symmetrical halves in each PRU-ICSS known as SLICE0 and SLICE1. Each slice will share several resources while capable of working independently of each other. There are two sets of XFR2VBUS for each Slice. PRUs also has the ability to submit 32-bit bursts transitions, but this will require RAT configuration.

Each of the Slices contains one RAT (Region based Address Translation) module. The RAT module is used to translate 32-bit address of the PRU core to 48-bit physical address.

The PRU cores within the subsystems also have access to all resources on the SoC through the External CBASS0 Interconnect. A subsystem local Interrupt Controller — INTC handles system input events and posts events back to the device-level host CPUs.

Figure 7-19 shows an overview of the PRU-ICSS Functional Block Diagram.

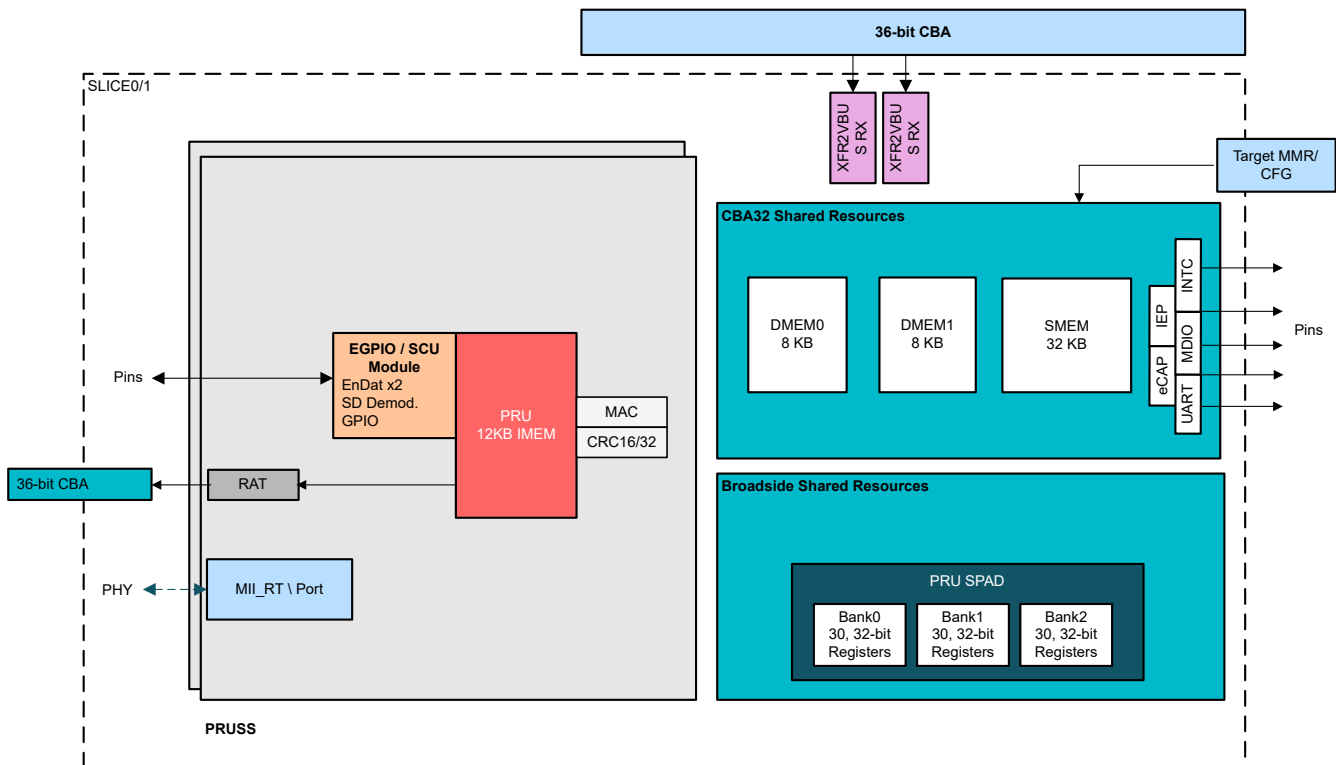

Figure 7-19. PRU-ICSS Functional Block Diagram

Table 7-33 summarizes the mapping between hardware modules and PRU0/1 cores.

Table 7-33. Hardware Module Broadside ID Mapping

Hardware Module	Broadside ID	
MPY/MAC	00	2 copies: PRU1/0
CRC16/32	01	2 copies: PRU1/0
SPAD Bank0	10	shared between PRU1/0

Table 7-33. Hardware Module Broadside ID Mapping (continued)

Hardware Module	Broadside ID	
SPAD Bank1	11	shared between PRU1/0
SPAD Bank2	12	shared between PRU1/0
RX L2	20/21	2 copies: PRU1/0
TX L2	40	2 copies: PRU1/0

7.2.4.1 PRU-ICSS Reset Management

The device supports warm reset isolation (Hard/Soft Reset, Watchdog Reset) on PRU-ICSS.

For more details on the PRU-ICSS Resets Isolation, see also the *ICSS Reset Isolation*.

7.2.4.2 PRU-ICSS Power and Clock Management

The PRU-ICSS supports two levels of clock gating. First level gates all clocks inside the PRU-ICSS when requested by the PSC (Power Sleep Controller). The second level allows user software to enable/disable clocks in the clock gating register ICSS_CGR_REG to some internal modules, as follows:

- IEP
- ECAPO
- UART0
- INTC

The appropriate configuration registers block controls its local module set inside PRU-ICSS.

7.2.4.2.1 PRU-ICSS CORE Clock Generation

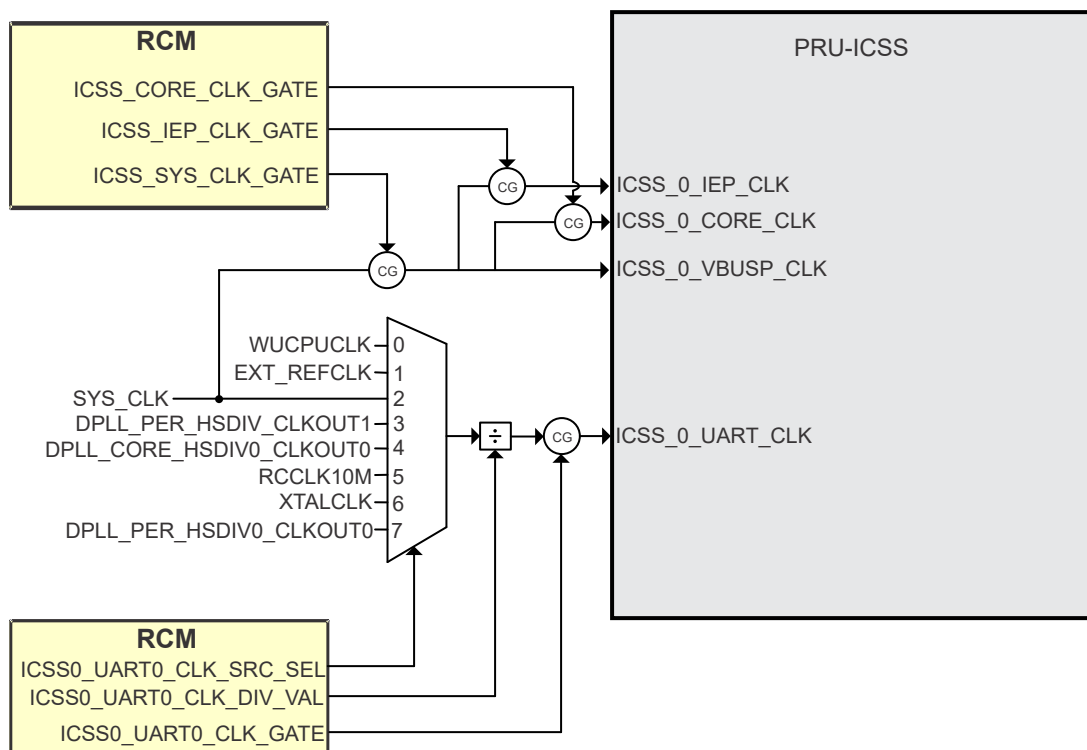
**Figure 7-20. PRU-ICSS Clock Diagram**

The CORE, BUS, and IEP Clock all use the 200 MHz SYS_CLK as a source clock. The UART clock is configurable by configuring the UART clock source select register as well as the UART clock divider value register. Each of these clock sources has a configurable clock gate that can be configured with the appropriate clock gate register

7.2.4.2.2 PRU-ICSS Idle State

The below lists the clock management settings applicable at PRU-ICSS subsystem level (first level of local power management).

A transition from an ACTIVE/Normal state to an IDLE state is performed as per the sequence:

1. The host processor requests that the PRU firmware goes into IDLE state and waits for acknowledgement.
2. The host issues Clock Stop Request for each module in ICSSM_CGR_REG register with gateable clocks defined at second power management level (see [Section 7.2.4.2](#))
3. The PRU-ICSS acknowledges IDLE Request and send Clock Stop Acknowledge to the host processor.
4. The PSC can de-assert PWR_CLK_EN
5. The main clocks can get turned off

A transition from an IDLE state to an ACTIVE/ Normal state is performed as per the sequence:

1. Turn on the main external clocks
2. The PSC can assert PWR_CLK_EN
3. The host will need to de-assert Clock Stop Request for each module, defined in ICSSM_CGR_REG register,
4. The PRU-ICSS firmware need to de-assert Clock Stop Acknowledge for each module defined in ICSSM_CGR_REG register and then wait for the Clock Stop Acknowledge de-assert
5. The PRU-ICSS firmware will de-assert Clock Stop Acknowledge

7.2.4.2.3 PRU-ICSS Protect

Write protect block allows software to enable safety protection to prevent corruption of key configuration and debug registers and the Instruction memories (IRAM's) of all PRU cores (PRU0/PRU1). Write protection is also supported for Data RAM0 and Data RAM1.

This is achieved by blocking the byte enables during a write transaction if enabled. When enabled, it will prevent any unwanted write transaction to these elements. To Enable/Disable this feature, software will first need to unlock the write access to this block through the PROT_UNLOCK_KEY register then configure the protection through PROT_CFG register and relock.

7.2.4.2.4 Module Clock Configurations at PRU-ICSS Top Level

IEP functional clock source selection:The clock source selection to the IEP module is done in register CTRLMMR_ICSSM_CLKSEL[19-16] IEP_CLKSEL (where n = 0 or 1) in the CTRL_MMR0 location. For more information on these PRU-ICSS level input clocks, refer to the .

Enhanced GPIO clock divider settings:In certain sample/shift clock settings of the PRU0 and PRU1 EGPIOs (when enabled in serial mode) two cascaded fractional dividers are done in the PR1_ICSSM_CFG top level configuration registers ICSSM_GPCFG0_REG and ICSSM_GPCFG1_REG. In addition, EGPIO clock active edge selection control can be exerted via the bit PRU0_GPI_CLK_MODE for PRU0 EGPIO and PRU1_GPI_CLK_MODE for the PRU1 EGPIO.

- For the serial PRU0's EGPOs:
 - ICSSM_GPCFG0_REG[24-20] PRU0_GPO_DIV1
 - ICSSM_GPCFG0_REG[19-15] PRU0_GPO_DIV0
- For the serial PRU0's EGPIs:
 - ICSSM_GPCFG0_REG[12-8] PRU0_GPI_DIV1
 - ICSSM_GPCFG0_REG[7-3] PRU0_GPI_DIV0
- For the serial PRU1's EGPOs:
 - ICSSM_GPCFG1_REG[24-20] PRU1_GPO_DIV1
 - ICSSM_GPCFG1_REG[19-15] PRU1_GPO_DIV0
- For the serial PRU1's EGPIs:

- ICSSM_GPCFG1_REG[12-8] PRU1_GPI_DIV1
- ICSSM_GPCFG1_REG[7-3] PRU1_GPI_DIV0

7.2.4.3 Other PRU-ICSS Module Functional Registers at Subsystem Level

Enhanced GPIO. The other functional mode setting for PRUs EGPIOs at PRU-ICSS top registers level are:

- ICSSM_GPCFG0_REG / ICSSM_GPCFG1_REG[14] PRU0_GPO_MODE (PRU0 or PRU1) — to select between direct or serial EGPO output mode of operation.
- ICSSM_GPCFG0_REG / ICSSM_GPCFG1_REG[25] PRU0_GPO_SH_SEL (PRU0 or PRU1) — to select between the EGPO shadow registers 0 and 1 used for output shifting. For more details, refer to the [Section 7.2.5.2.2.3.4, Enhanced General-Purpose Module Outputs \(R30\)](#).
- ICSSM_GPCFG0_REG / ICSSM_GPCFG1_REG[1-0] PRU0_GPI_MODE (PRU0 or PRU1) — selects the EGPI input mode of operation (selects between "direct input", "parallel capture", "28-bit shift" or "MII_RT" modes).
- ICSSM_GPCFG0_REG / ICSSM_GPCFG1_REG[13] PRU0_GPI_SB (PRU0 or PRU1) — start bit event status for 28-bit EGPI input shift mode. For more details, refer to the [Section 7.2.5.2.2.3, Enhanced General-Purpose Module Inputs \(R31\)](#).

PRUs scratchpad (SPAD) memory priority and configuration related bits are located in the ICSSM_SPP_REG register.

7.2.4.4 PRU-ICSS Memory Maps

The PRU-ICSS comprises various distinct addressable regions that are mapped to both a local and global memory map. The local memory maps are maps with respect to the PRU point of view. The global memory maps are maps with respect to the Host point of view, but can also be accessed by the PRU-ICSS. Each PRU-ICSS can also access the memories within the other PRU-ICSS subsystem without going through an external port, thanks to PRU-ICSS VBUSP expansion port.

7.2.4.4.1 PRU-ICSS Local Memory Map

The PRU-ICSS memory map is documented in [Table 7-34](#) (Instruction Space) and in [Table 7-35](#) (Data Space). Note that these two memory maps are implemented inside the PRU-ICSS and are local to the components of the PRU-ICSS.

7.2.4.4.1.1 PRU-ICSS Local Instruction Memory Map

Each PRU (PRU0 and PRU1) has a dedicated 12KB of Instruction Memory (12KB for PRU-ICSS) which needs to be initialized by an external to PRU-ICSS Host processor before a PRU core executes any instructions.

CAUTION

The PRU-ICSS PRU0/1_IRAM regions are ONLY accessible from controllers, external to the PRU-ICSS (like Arm) when the PRU0/PRU1 is NOT running. The access is via PRU-ICSS target port on the device CBASS0 interconnect.

Table 7-34. PRU-ICSS Local Instruction Memory Map

Start Address	PRU0	PRU1
0000 0000h	12 KB IRAM	12 KB IRAM

7.2.4.4.1.2 PRU-ICSS Local Data Memory Map

The local data memory map in [Table 7-35](#) allows each PRU core to access the PRU-ICSS addressable regions (both its own subsystem and the other subsystem) and the external host's memory map.

Table 7-35. PRU-ICSS Local Data Memory Map

Start Address	PRU0	PRU1
0000 0000h	Data 8KB RAM0	Data 8KB RAM1
0000 2000h	Data 8KB RAM1	Data 8KB RAM0

Table 7-35. PRU-ICSS Local Data Memory Map (continued)

Start Address	PRU0	PRU1
0000 8000h	RAT_SLICE0	RAT_SLICE0
0000 9000h	RAT_SLICE1	RAT_SLICE1
0001 0000h	Data 32 KB RAM2 (Shared RAM)	Data 32 KB RAM2 (Shared RAM)
0002 0000h	INTC	INTC
0002 2000h	PRU0 Control	PRU0 Control
0002 4000h	PRU1 Control	PRU1 Control
0002 4C00h	PROTECT	PROTECT
0002 5000h	TX_PRU0 Control	TX_PRU0 Control
0002 5800h	TX_PRU1 Control	TX_PRU1 Control
0002 6000h	CFG	CFG
0002 8000h	UART0	UART0
0002 E000h	IEP0	IEP0
0003 0000h	ECAP0	ECAP0
0003 2000h	MII_RT_CFG	MII_RT_CFG
0003 2400h	MII_MDIO	MII_MDIO
0003 3000h	MII_G_RT_CFG	MII_G_RT_CFG

7.2.4.4.2 PRU-ICSS Global Memory Map

The global view of the PRU-ICSS internal memories and control ports is shown in [Table 7-36](#). The offset addresses of each region are implemented inside the PRU-ICSS but the global device memory mapping places the PRU-ICSS target port in the address range shown in the external PRU-ICSS Host top-level memory map.

The global memory map is with respect to the Host point of view (that is, device Arm), but it can also be accessed by the PRU-ICSS itself. Note that PRU0 and PRU1 can use either the local or global addresses to access their internal memories, but using the local addresses provides access time several cycles faster than using the global addresses. This is because when accessing via the global address the access has to be routed through the CBASS0 switch fabric outside PRU-ICSS and back in through the PRU-ICSS target port.

Each of the PRU cores can access the rest of the device memory (including memory mapped peripheral and configuration registers) using the global memory space addresses.

Table 7-36. PRU-ICSS Global Memory Map

Offset Address	PRU-ICSS Target
0000 0000h	Data 8 KB RAM0
0000 2000h	Data 8 KB RAM1
0000 8000h	RAT_SLICE0
0000 9000h	RAT_SLICE1
0001 0000h	Data 32 KB RAM2 (shared)
0002 0000h	PRU-ICSS INTC
0002 2000h	PRU0 Control
0002 2400h	PRU0 Debug
0002 4000h	PRU1 Control
0002 4400h	PRU1 Debug
0002 4C00h	PROTECT
0002 6000h	PRU-ICSS CFG
0002 8000h	PRU-ICSS UART0
0002 E000h	IEP0
0002 F000h	Reserved

Table 7-36. PRU-ICSS Global Memory Map (continued)

Offset Address	PRU-ICSS Target
0003 0000h	ECAPO
0003 2000h	MII_RT_CFG
0003 2400h	MII_MDIO
0003 3000h	MII_G_RT_CFG
0003 4000h	PRU0 12 KB IRAM
0003 8000h	PRU1 12 KB IRAM

7.2.5 PRU-ICSS PRU Cores

This section describes the functionality of the two Programmable Real-time Unit (PRU) processors (PRU0 and PRU1), integrated in the device PRU-ICSS.

7.2.5.1 PRU Cores Overview

The PRU is a processor optimized for performing embedded tasks that require manipulation of packed memory mapped data structures, handling of system events that have tight real-time constraints and interfacing with systems external to the SoC. The PRU is both very small and very efficient at handling such tasks.

The major attributes of the PRU are shown in [Table 7-37](#).

Table 7-37. PRU Features

Attribute	Value
IO Architecture	Load/Store
Data Flow Architecture	Register to Register
<i>Core Level Bus Architecture</i>	
Type	4-Bus Harvard (1 Instruction, 3 Data)
Instruction I/F	32-Bit Modified VBUSP Controller
Memory I/F 0	32-Bit VBUSP Controller
Memory I/F 1	32-Bit VBUSP Controller
<i>Execution Model</i>	
Issue Type	Scalar
Pipelining	None (Purposefully)
Ordering	In Order
ALU Type	Unsigned Integer
<i>Registers</i>	
General Purpose (GP)	30 (R1 – R30)
External Status	0 (R31)
GP/Indexing	0 (R0)
Addressability in Instruction	Bit, Byte (8-bit), Half-word (16-bit), Word (32-bit), Pointer
<i>Addressing Modes</i>	
Load Immediate	16-bit Immediate
Load/Store – Memory	Register Base + Register Offset Register Base + 8-bit Immediate Offset Register Base with auto increment/decrement Constant Table Base + Register Offset Constant Table Base + 8-bit Immediate Offset Constant Table Base with auto increment/ decrement
Data Path Width	32-bit
Instruction Width	32-bit
Accessibility to Internal PRU Structures	Provides 32-bit VBUSP target with three regions: <ul style="list-style-type: none"> • Instruction RAM • Control/Status registers • Debug access to internal registers (R0-R31) and constant table

The processor is based on a four-bus architecture which allows instructions to be fetched and executed concurrently with data transfers. In addition, an input is provided in order to allow external status information

to be reflected in the internal processor status register. Figure 7-21 shows a block diagram of the processing element and the associated instruction RAM/ROM that contains the code that is to be executed.

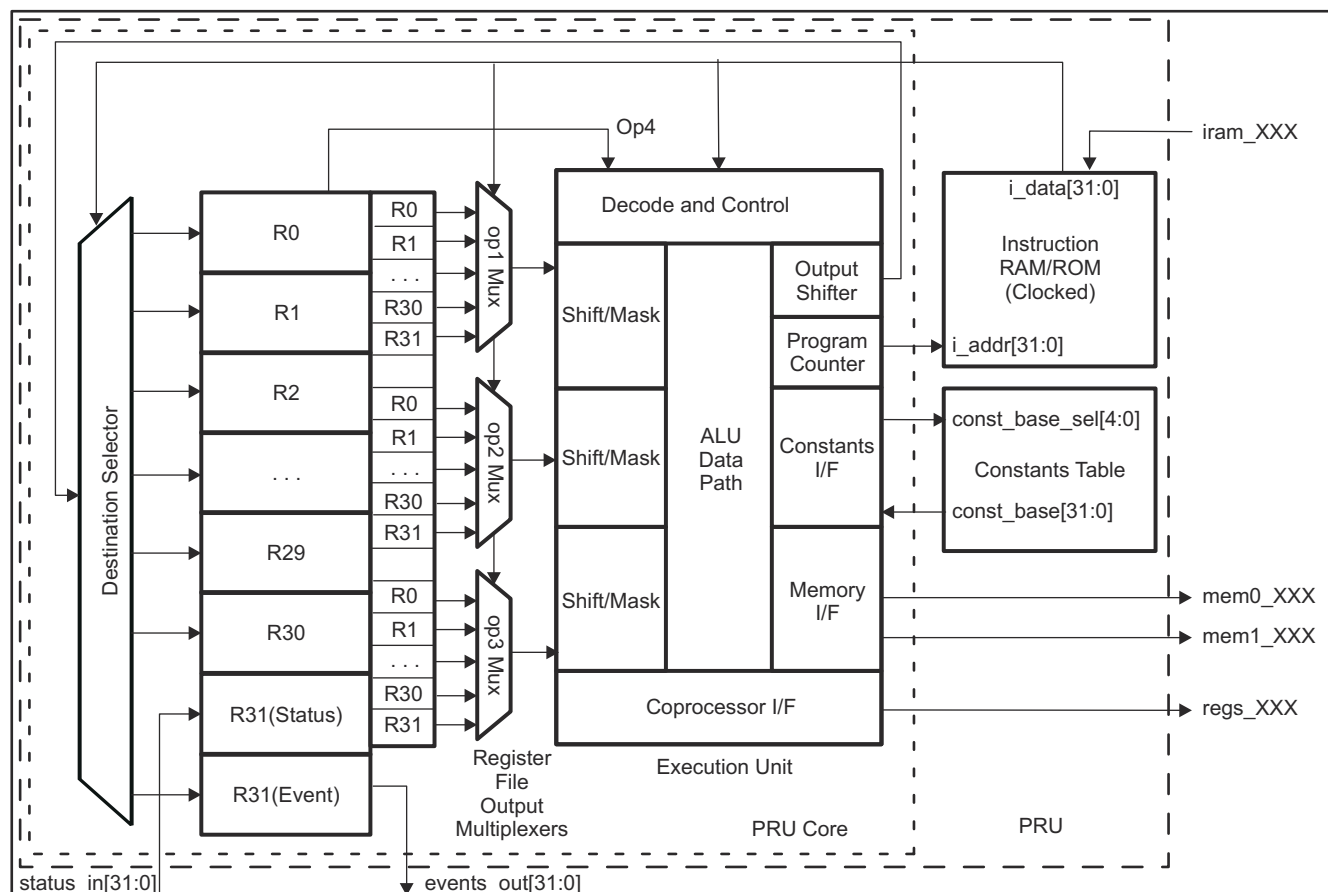

icss-005a

Figure 7-21. PRU Block Diagram

7.2.5.2 PRU Cores Functional Description

This section describes the PRU cores supported functionality by describing the constant table, module interface and enhanced GPIOs.

7.2.5.2.1 PRU Constant Table

The PRU Constants Table is a structure of hard-coded memory addresses for commonly used peripherals and memories. The constants table is used for more efficiently load/store data to these commonly accessed addresses by:

- Eliminating the PRU instruction that pre-loads a hard-coded address into the internal register file.
- Maximizing the usage of the PRU register file for embedded processing applications by moving many of the commonly used constant or deterministically calculated base addresses from the internal register file to an external table.

Table 7-38. PRU0/1 Constant Table

Entry No.	Region Pointed To	Value [31:0]
0	PRU-ICSS INTC (local)	0002_0000h
1	PRU-ICSS IEP (local)	0002_F000h
2	PRU-ICSS IEP_0x100 (local)	0002_F100h
3	PRU-ICSS ECAPO (local)	0003_0000h
4	PRU-ICSS CFG (local)	0002_6000h

Table 7-38. PRU0/1 Constant Table (continued)

Entry No.	Region Pointed To	Value [31:0]
5	PRU-ICSS CFG_0x100 (local)	0002_6100h
6	PRU-ICSS INTC_0x200 (local)	0002_0200h
7	PRU-ICSS UART0 (local)	0002_8000h
8	PRU-ICSS IEP0_0x100 (local)	0002_E100h
9	PRU-ICSS CFG (local)	0003_3000h
10	RESERVED	RERVED
11	PRU-ICSS PRU0 Control (local)	0002_2000h PRU0
	RESERVED	RESERVED
	RESERVED	RESERVED
	PRU-ICSS PRU1 Control (local)	0002_4000h PRU1
12	RESERVED	RESERVED
13	RESERVED	RESERVED
14	RESERVED	RESERVED
15	Reserved	6000_0000h
16	Reserved	7000_0000h
17	Reserved	8000_0000h
18	Reserved	9000_0000h
19	Reserved	A000_0000h
20	Reserved	B000_0000h
21	MDIO (local)	0003_2400h
22	RAT SLICE0 (local)	0000_8000h PRU0
	RAT SLICE1 (local)	0000_9000h PRU1
23	Reserved	C000_0000h
24	PRU-ICSS PRU0/PRU1 Data RAM (local)	0000_0n00h, n = c24_blk_index[3:0]
25	PRU-ICSS PRU1/PRU0 Data RAM (local)	0000_2n00h, n = c25_blk_index[3:0]
26	PRU-ICSS IEP (local)	0002_En00h, n = c26_blk_index[3:0]
27	PRU-ICSS MII_RT/SGMII0_CFG/SGMII1_CFG (local)	0003_2n00h, n = c27_blk_index[3:0]
28	PRU-ICSS Shared RAM (local)	00nn_nn00h, nnnn = c28_pointer[15:0]
29	Reserved	0Dnn_nn00h, nnnn = c29_pointer[15:0]
30	Reserved	0Enn_nn00h, nnnn = c30_pointer[15:0]
31	Reserved	0Fnn_nn00h, nnnn = c31_pointer[15:0]

Note

The addresses in constants entries 24–31 are partially programmable. Their programmable bit field (for example, c24_blk_index[3:0]) is programmable through the PRU CTRL register space. As a general rule, the PRU should configure this field before using the partially programmable constant entries.

7.2.5.2.2 PRU Module Interface

The PRU module interface consists of the PRU internal registers 30 and 31 (R30 and R31). [Figure 7-22](#) shows the PRU module interface and the functionality of R30 and R31. The register R31 serves as an interface with the dedicated PRU general purpose input (GPI) pins and PRU-ICSS INTC. Reading R31 returns status information from the GPI pins and PRU-ICSS INTC via the PRU Real Time Status Interface. Writing to R31 generates PRU system events via the PRU Event Interface. The register R30 serves as an interface with the dedicated PRU general purpose output (GPO) pins.

Note

The below sections cover different functional modes of the PRUn cores, (where n=0,1), enhanced GPIO (EGPIO) interface. The register bits which control EGPIO functionalities are part of the (PRU-ICSS CFG) space. For descriptions of these EGPIO register bitfield controls, refer to the [Section 7.2.4.3](#).

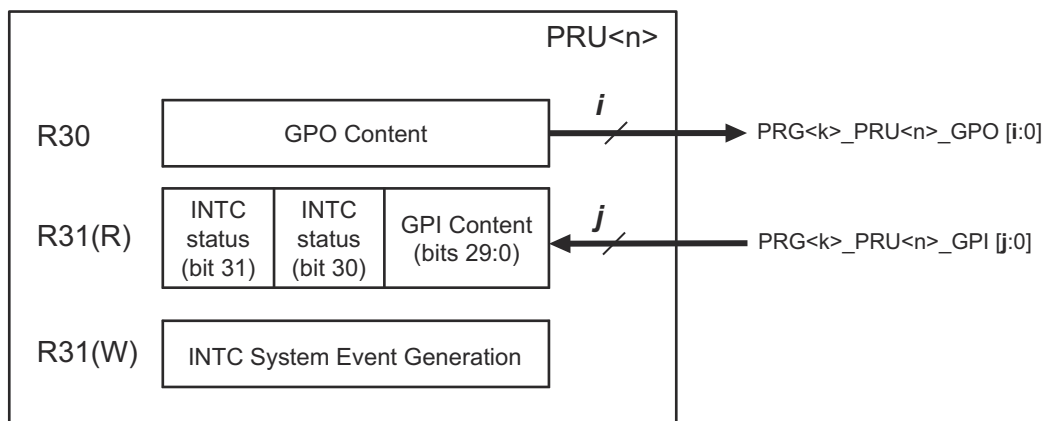

icss-005b

Figure 7-22. PRU Module Interface

7.2.5.2.2.1 Real-Time Status Interface Mapping (R31): Interrupt Events Input

The PRU Real Time Status Interface directly feeds information into register 31 (R31) of the PRU's internal register file. The firmware on the PRU uses the status information to make decisions during execution. The status interface is comprised of signals from different modules inside of the PRU-ICSS which require some level of interaction with the PRU. More details on the Host interrupts imported into bit 30 and 31 of register R31 of both the PRUs is provided in the , *PRU-ICSS Local Interrupt Controller*.

Table 7-39. Real-Time Status Interface Mapping (R31) Field Descriptions

Bit	Field	Description
31	pru_intr_in[1]	PRU Host Interrupt 1 from local PRU-ICSS INTC
30	pru_intr_in[0]	PRU Host Interrupt 0 from local PRU-ICSS INTC
29-0	pru<n>_r31_status[29:0]	Status inputs from primary input via Enhanced GPI port

7.2.5.2.2.2 Event Interface Mapping (R31): PRU System Events

This PRU Event Interface directly feeds pulsed event information out of the PRU's internal ALU. These events are exported out of the PRU-ICSS and need to be connected to the system interrupt controller at the SoC level. The event interface can be used by the firmware to create software interrupts from the PRU to the Host processor.

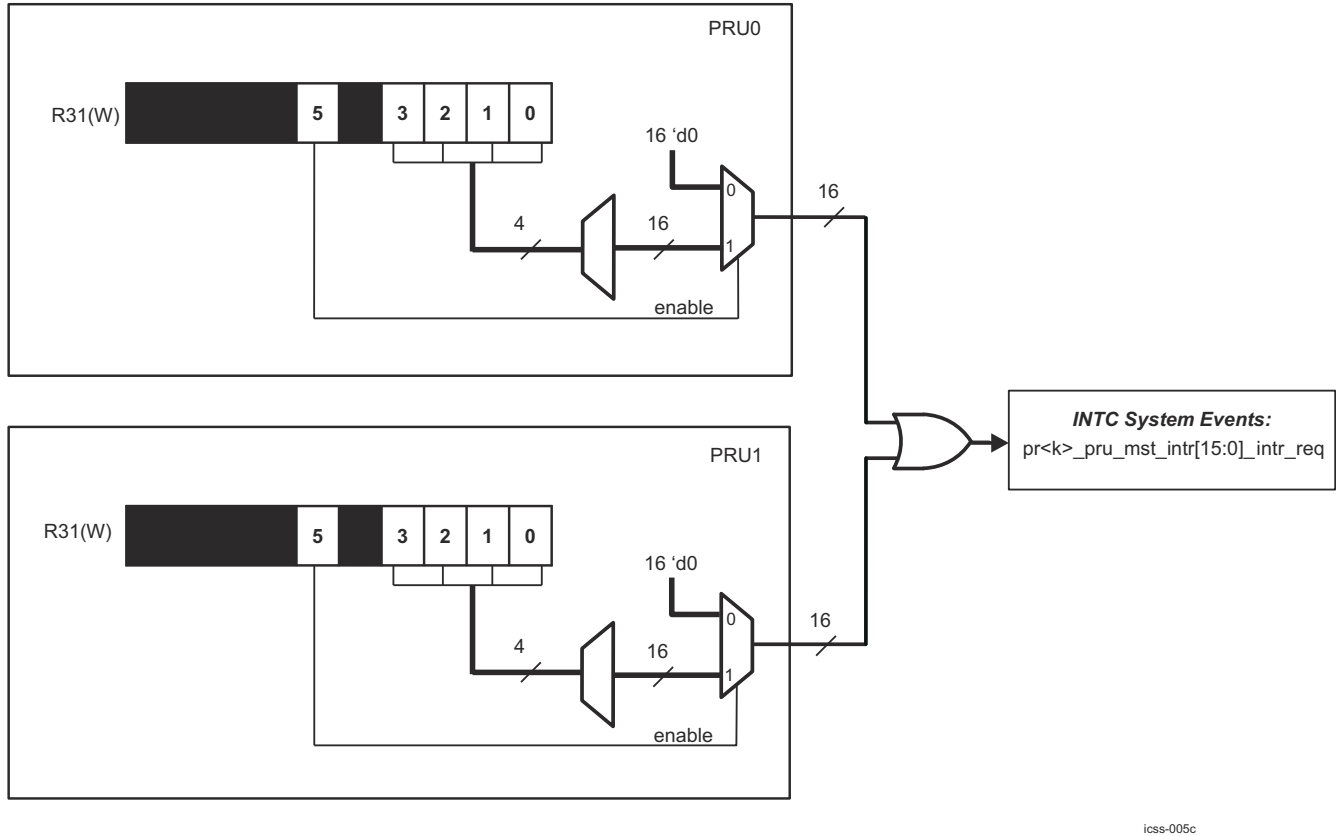

Figure 7-23. Event Interface Mapping (R31)

Table 7-40. Event Interface Mapping (R31) Field Descriptions

Bit	Field	Description
31-6	Reserved	
5	pru<n>_r31_vec_valid	Valid strobe for vector output
4	Reserved	
3-0	pru<n>_r31_vec[3:0]	Vector output

Simultaneously writing a '1' to pru<n>_r31_vec_valid (R31 bit 5) and a channel number from 0 to 15 to pru<n>_r31_vec[3:0] (R31 bits 3-0) creates a pulse on the output of the corresponding pr<k>_pru_mst_intr[x]_intr_req INTC system event. For example, writing '100000' will generate a pulse on prk_pru_mst_intr[0]_intr_req, writing '100001' will generate a pulse on prk_pru_mst_intr[1]_intr_req, and so on to where writing '101111' will generate a pulse on prk_pru_mst_intr[15]_intr_req and writing '0xxxxx' will not generate any system event pulses. The output values from both PRU cores in a subsystem are ORed together.

The output channels 0-15 are connected to the INTC system events 16-31, respectively. This allows the PRU to assert one of the system events 16-31 by writing to its own R31 register. The system event is used to either post a completion event to one of the host CPUs (Arm) or to signal the other PRU. The host to be signaled is determined by the system interrupt to interrupt channel mapping (programmable). The 16 events are named as prk_pru_mst_intr<15:0>_intr_req. See the , *PRU-ICSS Interrupt Requests Mapping*, in the section, *PRU-ICSS Local Interrupt Controller*, for more details.

7.2.5.2.2.3 General-Purpose Inputs (R31): Enhanced PRU GP Module

The PRU-ICSS implements an enhanced General Purpose Input/Output (GPIO) module with SCU that supports the following general-purpose input modes: direct input, 16-bit parallel capture, 28-bit serial shift in, and MII_RT. Register R31 serves as an interface with the general-purpose inputs. [Table 7-41](#) describes the input modes in detail.

Note

Each PRU core can only be configured for one GPI mode at a time. Each mode uses the same R31 signals and internal register bits for different purposes. A summary is found in [Table 7-42](#).

Note

The ICSSM_GPCFG0_REG register, bitfield [29-26] PR1_PRU0_GP_MUX_SEL (PRU0 or PRU1) in the PRU-ICSS CFG register space needs to be set to 0h for GP mode. For a given PRU core, the following IO modes are mutually exclusive: GP mode, Sigma Delta mode, and 3 channel Peripheral I/F mode.

Table 7-41. PRU R31 (GPI) Modes

Mode	Function	Configuration
Direct input	GPI[19:0] feeds directly into the PRU R31	Default state
16-bit parallel capture	DATAIN[0:15] is captured by the posedge or negedge of CLOCKIN	<ul style="list-style-type: none"> Enabled by ICSSM_GPCFG0_REG register (PRU0 or PRU1) CLOCKIN edge selected by ICSSM_GPCFG0_REG register
28-bit shift in	DATAIN is sampled and shifted into a 28-bit shift register. <ul style="list-style-type: none"> Shift Counter (Cnt_16) feature is mapped to pru<n>_r31_status[28]. SB (Start Bit detection) feature is mapped to pru<n>_r31_status[29] 	<ul style="list-style-type: none"> Enabled and disabled by ICSSM_GPECFG0_REG register (PRU0 or PRU1) Cnt_16 is self clearing and is connected to the PRU INTC Start Bit (SB) is cleared by ICSSM_GPECFG0_REG register Start Bit value (0h or 1h) selected by ICSSM_GPECFG0_REG register
ENDAT	The 3 channel Peripheral Interface supports functionality for operations utilized the EnDat 2.2 and BiSS protocols.	Enabled by ICSSM_GPCFG0_REG[1-0] PRU0_GPI_MODE register (value: 1h), where n = 0 or 1
MII_RT	mii_rt_r31_status [29:0] internally driven by the MII_RT module	Enabled by ICSSM_GPCFG0_REG[1-0] PRUn_GPI_MODE register (value: 2h), where n = 0 or 1
Sigma Delta	Up to nine channels of concurrent counting with clock source configuration for each channel.	Enabled by ICSSM_GPCFG0_REG[1-0] PRUn_GPI_MODE register (value: 3h), where n = 0 or 1

Table 7-42. PRU GPI Signals and Configurations

Pad Names at Device Level ⁽¹⁾	GPI Modes					
	Direct input	Parallel Capture	28-Bit Shift in	ENDAT	MII	Sigma Delta
PRG<k>_PRU<n>_GPI 0	GPI0	DATAIN0	DATAIN		RXD[0]	SD0_CLK
PRG<k>_PRU<n>_GPI 1	GPI1	DATAIN1			RXD[1]	SD0_DATA
PRG<k>_PRU<n>_GPI 2	GPI2	DATAIN2			RXD[3]	SD1_CLK
PRG<k>_PRU<n>_GPI 3	GPI3	DATAIN3			RXDV	SD1_DATA
PRG<k>_PRU<n>_GPI 4	GPI4	DATAIN4			RXER	SD2_CLK
PRG<k>_PRU<n>_GPI 5	GPI5	DATAIN5			RX_CLK	SD2_DATA
PRG<k>_PRU<n>_GPI 6	GPI6	DATAIN6				SD3_CLK

Table 7-42. PRU GPI Signals and Configurations (continued)

Pad Names at Device Level ⁽¹⁾	GPI Modes					
	Direct input	Parallel Capture	28-Bit Shift in	ENDAT	MII	Sigma Delta
PRG<k>_PRU<n>_GPI 7	GPI7	DATAIN7			RXLINK	SD3_DATA
PRG<k>_PRU<n>_GPI 8	GPI8	DATAIN8			COL	SD4_CLK
PRG<k>_PRU<n>_GPI 9	GPI9	DATAIN9		ENDAT0_IN	CRS	SD4_DATA
PRG<k>_PRU<n>_GPI 10	GPI10	DATAIN10		ENDAT1_IN		SD5_CLK
PRG<k>_PRU<n>_GPI 11	GPI11	DATAIN11		ENDAT2_IN		SD5_DATA
PRG<k>_PRU<n>_GPI 12	GPI12	DATAIN12				SD6_CLK
PRG<k>_PRU<n>_GPI 13	GPI13	DATAIN13				SD6_DATA
PRG<k>_PRU<n>_GPI 14	GPI14	DATAIN14				SD7_CLK
PRG<k>_PRU<n>_GPI 15	GPI15	DATAIN15				SD7_DATA
PRG<k>_PRU<n>_GPI 16	GPI16	CLOCKIN		R31_IN[16]	TX_CLK,R31_IN[16]	SD8_CLK, R31_IN[16]
PRG<k>_PRU<n>_GPI 17	GPI17					SD8_DATA
PRG<k>_PRU<n>_GPI 18	GPI18					
PRG<k>_PRU<n>_GPI 19	GPI19					

(1) These pins are also used for Sigma Delta or Peripheral I/F mode.

7.2.5.2.2.3.1 PRU EGPIs Direct Input

The pru<n>_r31_status[0:19] bits of the internal PRU register file are mapped to device-level, general purpose input pins (PRU0_GPI[0:19]). In GPI Direct Input mode, PRU0_GPI[0:19] feeds directly to pru<n>_r31_status[0:19].

Each PRU of the PRU-ICSS has a separate mapping to device input signals - PRGn_PRU0_GPI[19:0] for the PRU0 core and PRGn_PRU1_GPI[19:0] for the PRU1 core. There are 80 general purpose inputs in total. For more details, refer also to the . See the device's system reference guide or datasheet for device specific pin mapping.

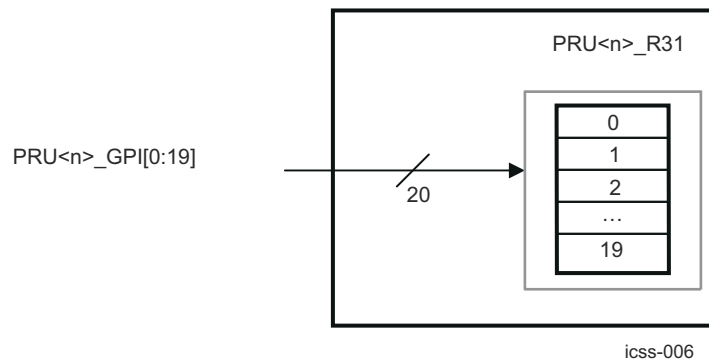

Figure 7-24. PRU R31 (EGPI) Direct Input Mode Block Diagram

7.2.5.2.2.3.2 PRU EGPIs 16-Bit Parallel Capture

The pru<n>_r31_status[0:15] and pru<n>_r31_status[16] bits of the internal PRU register file mapped to device-level, general purpose input pins (PRU0_DATAIN [0:15] and PRU0_CLOCKIN, respectively). PRU0_CLOCKIN is designated for an external strobe clock, and is used to capture PRU0_DATAIN [0:15].

The PRU<n>_DATAIN can be captured either by the positive or the negative edge of PRU<n>_CLOCK, programmable through the PRU-ICSS CFG register space. If the clocking is configured through the PRU-ICSS CFG register to be positive, then it will equal PRU<n>_CLOCK; however, if the clocking is configured to be negative, then it will equal PRU<n>_CLOCK inverted.

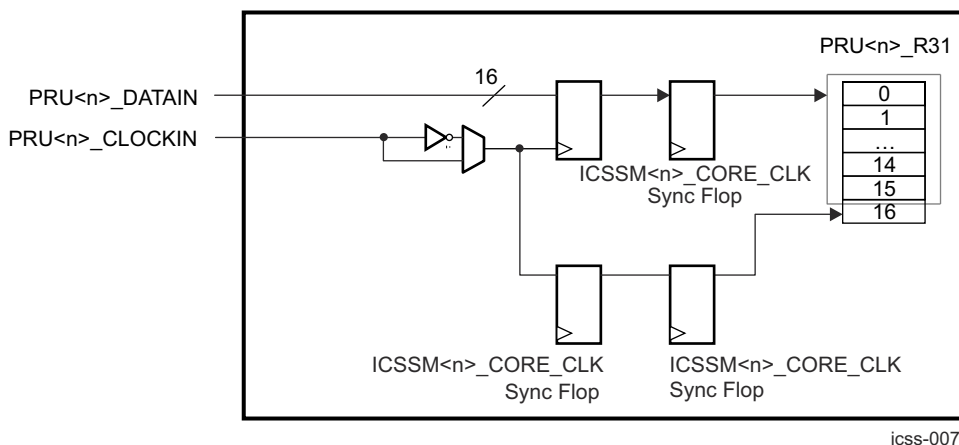

Figure 7-25. PRU R31 (EGPI) 16-Bit Parallel Capture Mode Block Diagram

7.2.5.2.2.3.3 PRU EGPIs 28-Bit Shift In

In 28-bit shift in mode, the device-level, general-purpose input pin PRU<n>_DATAIN is sampled and shifted into a 28-bit shift register on an internal clock pulse. The register fills in LSB order (from bit 0 to 27) and then overflows into a bit bucket. The 28-bit register is mapped to pru<n>_r31_status[0:27] and can be cleared in software through the ICSSM_GPCFG0_REG[13] PRU0_GPI_SB register (PRU0 or PRU1).

Note that by default, the PRU will continually capture and shift the DATAIN input when the GPI mode has been set. However, clearing the ICSSM_GPCFG0_REG[1] PRU0_GPI_SHIFT_EN bit will freeze the shift operation.

The shift rate is controlled by the effective divisor of two cascaded dividers applied to the ICSSM<n>_CORE_CLK clock (200MHz). These cascaded dividers can each be configured through the PRU-ICSS CFG register space to a value of {1, 1.5, ..., 16}. Table 7-43 shows sample effective clock values and the divisor values that can be used to generate these clocks.

Table 7-43. PRU EGPIs Effective Clock Values

Generated clock	PRU0_GPI_DIV0	PRU0_GPI_DIV1
8-MHz	12.5 (17h)	2 (02h)
10-MHz	10 (12h)	2 (02h)
16-MHz	16 (1Eh)	1 (00h)
20-MHz	10 (12h)	1 (00h)

The 28-bit shift mode also supports the following features:

- SB (Start Bit detection) is mapped to pru<n>_r31_status[29] and is set when the first 1 (default) or 0 is captured on PRU<n>_DATAIN. The Start Bit value (1 or 0) is configured through the ICSSM_GPCFG0_REG[0] PRU0_GPI_SB_P bit (PRU0 or PRU1). The SB flag in pru<n>_r31_status[29] is cleared in software through the PRU-ICSS CFG register space.

ADVANCE INFORMATION

- Cnt_16 (Shift Counter) is mapped to pru<n>_r31_status[28] and is set on every 16 shift clock samples after the Start Bit has been received. CNT_16 is self clearing and is connected to the local PRU-ICSS INTCC. See the *PRU-ICSS Local Interrupt Controller* for more details.
- The ICSSM_GPECFG0_REG[1] PRU0_GPI_SHIFT_EN bit can stop or freeze the current shift operation and disable the search for a new Start Bit, if an SB event has not occurred.

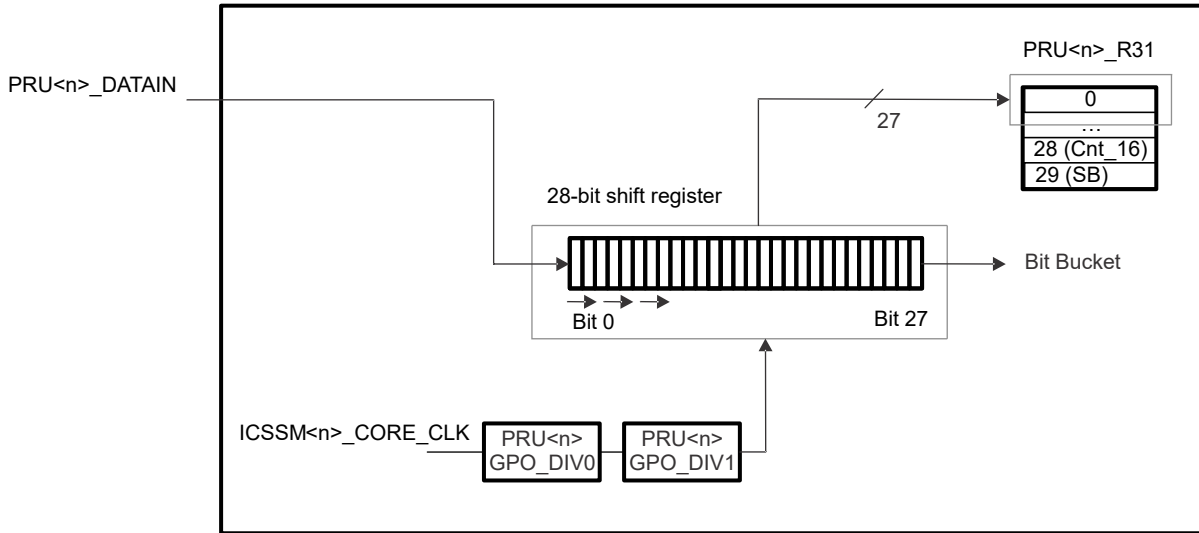

pruss-008

Figure 7-26. PRU R31 (EGPI) 28-Bit Shift Mode

7.2.5.2.2.3.3.1 PRU EGPI Programming Model

Follow this steps to configure the PRU EGPI in 28-bit shift input mode:

1. Clear ICSSM_GPECFG0_REG[1] PRU0_GPI_SHIFT_EN bit (PRU0 or PRU1)
2. Clear/Set ICSSM_GPECFG0_REG[0] PRU0_GPI_SB_P bit (PRU0 or PRU1)
3. Clear Start Bit by writing 1h to ICSSM_GPCFG0_REG[13] PRU0_GPI_SB bit
4. Program the dividers through:
 - ICSSM_GPCFG0_REG[24-20] PRU0_GPO_DIV1 bit (PRU0 or PRU1)
 - ICSSM_GPCFG0_REG[19-15] PRU0_GPO_DIV0 bit (PRU0 or PRU1)
5. Enable Shift Input Mode by writing to ICSSM_GPECFG0_REG[1] PRU0_GPI_SHIFT_EN bit

7.2.5.2.2.3.4 General-Purpose Outputs (R30): Enhanced PRU GP Module

The PRU-ICSS implements an enhanced General Purpose Input/Output (GPIO) module that supports two general-purpose output modes: direct output and shift out.

Table 7-44 describes these modes in detail.

Note

Each PRU core can only be configured for one GPO mode at a time. Each mode uses the same R30 signals and internal register bits for different purposes. A summary is found in Table 7-44.

Note

The ICSSM_GPCFG0_REG register, bitfield [29-26] PR1_PRU0_GP_MUX_SEL (PRU0 or PRU1) in the PRU-ICSS CFG register space needs to be set to 0h for GP mode. For a given PRU core, the following IO modes are mutually exclusive: GP mode, Sigma Delta mode, and 3 channel Peripheral I/F mode.

Table 7-44. PRU R30 (EGPO) Output Mode

Mode	Function	Configuration
Direct output	pru<n>_r30[19:0] feeds directly to GPO[19:0]	Default state
Shift out	<ul style="list-style-type: none"> pru<n>_r30[0] is shifted out on DATAOUT on every rising edge of pru<n>_r30[1] (CLOCKOUT). LOAD_GPO_SH0 (Load Shadow Register 0) is mapped to pru<n>_r30[29]. LOAD_GPO_SH1 (Load Shadow Register 1) is mapped to pru<n>_r30[30]. ENABLE_SHIFT is mapped to pru<n>_r30[31]. 	Enabled by ICSSM_GPCFG0_REG register (PRU0 or PRU1) Free Running Clock or Fixed Clock Count Mode selected by ICSSM_GPECFG0_REG register.

Table 7-45. GPO Mode Descriptions

Pad Names at Device Level ⁽¹⁾	GPO Modes	
	Direct output	Shift out
PRG<k>_PRU<n>_GPO0	GPO0	DATAOUT
PRG<k>_PRU<n>_GPO1	GPO1	CLOCKOUT
PRG<k>_PRU<n>_GPO2	GPO2	
PRG<k>_PRU<n>_GPO3	GPO3	
PRG<k>_PRU<n>_GPO4	GPO4	
PRG<k>_PRU<n>_GPO5	GPO5	
PRG<k>_PRU<n>_GPO6	GPO6	
PRG<k>_PRU<n>_GPO7	GPO7	
PRG<k>_PRU<n>_GPO8	GPO8	
PRG<k>_PRU<n>_GPO9	GPO9	
PRG<k>_PRU<n>_GPO10	GPO10	
PRG<k>_PRU<n>_GPO11	GPO11	
PRG<k>_PRU<n>_GPO12	GPO12	
PRG<k>_PRU<n>_GPO13	GPO13	
PRG<k>_PRU<n>_GPO14	GPO14	
PRG<k>_PRU<n>_GPO15	GPO15	
PRG<k>_PRU<n>_GPO16	GPO16	
PRG<k>_PRU<n>_GPO17	GPO17	
PRG<k>_PRU<n>_GPO18	GPO18	
PRG<k>_PRU<n>_GPO19	GPO19	

(1) These pins are also used for Sigma Delta or Peripheral I/F mode.

7.2.5.2.3.4.1 PRU EGPOs Direct Output

The PRU0_r30 [19:0] bits of the internal PRU register files are mapped to device-level, general-purpose output pins (PRU0_GPO[0:19]). In GPO Direct Output mode, PRU0_r30[0:19] feed directly to PRU0_GPO[0:19]. Each PRU of the PRU-ICSS has a separate mapping to pins, so that there are 40 total general-purpose outputs from the PRU-ICSS. See the device's system reference guide or datasheet for device-specific pin mapping.

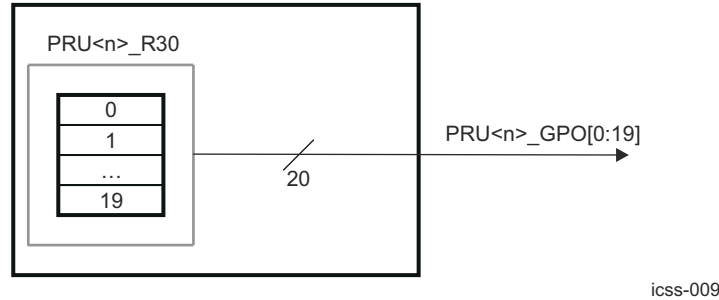

Figure 7-27. PRU R30 (EGPO) Direct Output Mode Block Diagram

7.2.5.2.3.4.2 PRU EGPO Shift Out

In shift out mode, data is shifted out of PRU0_r30[0] (PRU0_DATAOUT) on every rising edge of PRU0_r30[1] (PRU0_CLOCK). The shift rate is controlled by the effective divisor of two cascaded dividers applied to the PRU-ICSS<n>_CORE_CLK clock (200MHz). These cascaded dividers can each be configured through the PRU-ICSS CFG register space to a value of {1, 1.5, ..., 16}. Table 7-46 shows sample effective clock values and the divisor values that can be used to generate these clocks. Note that shift out mode supports two clocking submodes - Free Running Clock Mode (default) and Fixed Clock Count Mode. The clocking submode is selected through ICSSM_GPECFG0_REG[5] PRU0_GPO_SHIFT_CLK_FREE. In Free Running Clock Mode, PRU0_CLOCKOUT is a free running clock that starts when the PRU GPO mode is set to shift out mode.

Table 7-46. Effective Clock Values

Generated Clock	PRU0_GPO_DIV0	PRU0_GPO_DIV1
8 MHz	12.5 (17h)	2 (02h)
10 MHz	10 (12h)	2 (02h)
16 MHz	16 (1Eh)	1 (00h)
20 MHz	10 (12h)	1 (00h)

Shift out mode uses two 16-bit shadow registers (GPO_SH0 and GPO_SH1) to support ping-pong buffers. Each shadow register has independent load controls programmable through PRU0_r30[29:30] (PRU0_LOAD_GPO_SH[0:1]). While PRU0_LOAD_GPO_SH[0:1] is set, the contents of PRU<n>_R30[0:15] are loaded into GPO_SH0 and GPO_SH1 shadow registers.

The data shift will start from the LSB or MSB of GPO_SH0 when PRU<n>_R30[31] (PRU0_ENABLE_SHIFT) is set. The LSB or MSB setting is configurable through ICSSM_GPECFG0_REG[4] PRU0_GPO_SHIFT_SWAP. Note that if no new data is loaded into GPO_SH0/GPO_SH1 after shift operation, the shift operation will continue looping and shifting out the pre-loaded data.

For Free Running Clock Mode, the shift operation will continue until PRU0_ENABLE_SHIFT is cleared. When PRU0_ENABLE_SHIFT is cleared, the shift operation will finish shifting out the current shadow register, stop, and then reset.

For Fixed Clock Count Mode, the number of data bits to be shifted out is defined by ICSSM_GPECFG0_REG[15-8] PRU0_GPO_SHIFT_CNT. PRU<n>_CLOCKOUT will stop either high or low with the last data bit. The last data bit will remain persistent. However, the clock stop state is configurable through ICSSM_GPECFG0_REG[16] PRU0_GPO_SHIFT_CLK_HIGH.

The source of PRG<k>_PRU<n>_GPO[2:15] is configurable by ICSSM_GPECFG0_REG[6] PRU0_GPO_SHIFT_GP_EN. By default, if any device-level pins mapped to PRU<n>_R30[2-15] are configured for the PRG<k>_PRU<n>_GPO[2:15] pinmux mode, then these pins will reflect the shadow register value written to PRU<n>_R30. Any pin configured for a different pinmux setting will not reflect the shadow register value written to PRU<n>_R30. However, setting ICSSM_GPECFG0_REG[6] PRU0_GPO_SHIFT_GP_EN = 1h allows PRU<n>_R30[2:15] to be controlled by PRU<n>_R30_SHADOW[2-15], which is updated by PRU<n>_R30[2:15] when PRU<n>_R30[28] = 1h.

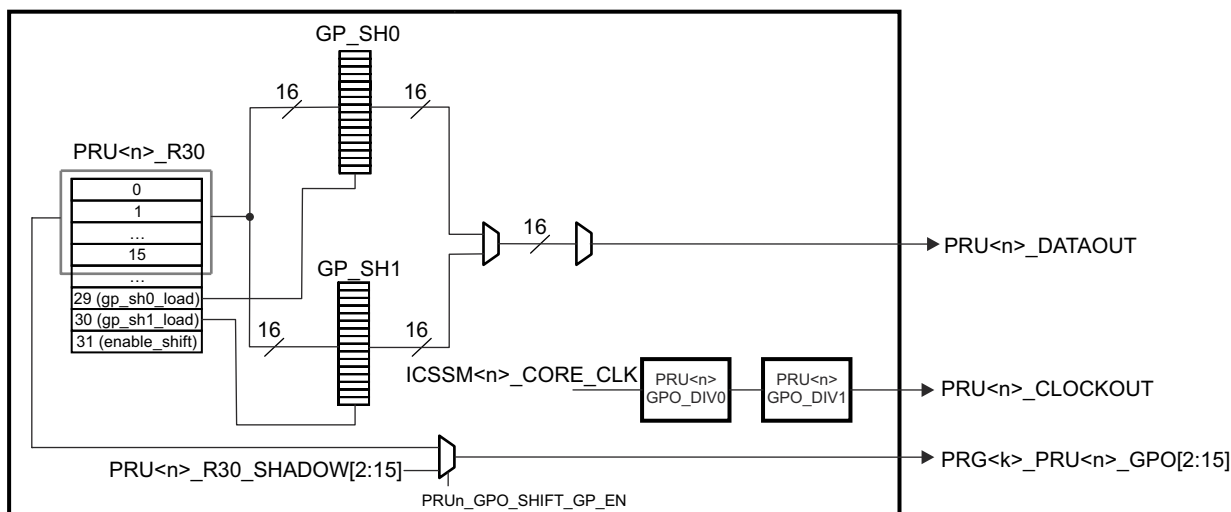

icss-010

Figure 7-28. PRU R30 (GPO) Shift Out Mode Block Diagram

2.5.2.2.3.4.2.1 PRU EGPO Programming Model

After the PRU is initialized, the software should only enable Shift Out Mode configuration per initialization.

7.2.5.2.2.3.5 Sigma Delta (SD) Decimation Filtering

Sigma-delta Sinc filtering is achieved by the combination of PRU hardware and firmware. PRU hardware provides hardware integrators that do the accumulation part of Sinc filtering, while the differentiation part is done in firmware.

The integrator serves to count the number of 1's per clock event. Each channel has three cascaded counters, which are the accumulators for the Sinc3 filter. Each counter is 28 bits, giving a maximum count of 268,435,456. Each channel has a free running rollover clock counter. This sample counter updates the count value on the effective clock event for that channel. Each channel also contains a programmable counter compare block, and the compare register has a size of 8 bits. However, the minimum value is 4 and maximum value is 256 due to the 28-bit accumulator. Once sample counter compare value is reached, the shadow register copy is updated and the shadow register copy flag is set.

Features of the integrators in PRUs SD Demodulator:

- Up to 9 channels concurrent counting
- Software can read all 3 stages accumulators
- Flexible clock source configuration for each channel; option of independent clock source for each channel or one clock source for three channels
- Programmable, 8-bit sample counter compare register; used to set the OSR of Sinc filter
- Three 28-bit cascaded counters per channel for accumulation, only Sinc3 and Sinc2 modes supported
- Common channel enable (all channels are active or none are active)
- Fast 1 and 0 min/max count sliding programmable window for each of the 9 channels

7.2.5.2.2.3.5.1 Sigma Delta Block Diagram and Signals

The Sigma Delta's I/Os are multiplexed with the PRU GPI/GPO signals, as shown in Table 7-47.

Note: The PR<k>_PRU<n>_GP_MUX_SEL bitfield in the ICSSM_GPCFG0_REG register (where k = 0 or 1 and n = 0 or 1) must be set to 3h for configure the GPI/GPO signals for SD mode.

Table 7-47. PRU GPI Signals and Configurations for Sigma Delta

Signal Names at Device Level ⁽¹⁾	Sigma Delta (SD) Mode	Function
PRG<k>_PRU<n>_GPI0	SD0_CLK	SD demodulator clock channel 0
PRG<k>_PRU<n>_GPI1	SD0_D	SD demodulator data channel 0

Table 7-47. PRU GPI Signals and Configurations for Sigma Delta (continued)

Signal Names at Device Level ⁽¹⁾	Sigma Delta (SD) Mode	Function
PRG<k>_PRU<n>_GPI2	SD1_CLK	SD demodulator clock channel 1
PRG<k>_PRU<n>_GPI3	SD1_D	SD demodulator data channel 1
PRG<k>_PRU<n>_GPI4	SD2_CLK	SD demodulator clock channel 2
PRG<k>_PRU<n>_GPI5	SD2_D	SD demodulator data channel 2
PRG<k>_PRU<n>_GPI6	SD3_CLK	SD demodulator clock channel 3
PRG<k>_PRU<n>_GPI7	SD3_D	SD demodulator data channel 3
PRG<k>_PRU<n>_GPI8	SD4_CLK	SD demodulator clock channel 4
PRG<k>_PRU<n>_GPI9	SD4_D	SD demodulator data channel 4
PRG<k>_PRU<n>_GPI10	SD5_CLK	SD demodulator clock channel 5
PRG<k>_PRU<n>_GPI11	SD5_D	SD demodulator data channel 5
PRG<k>_PRU<n>_GPI12	SD6_CLK	SD demodulator clock channel 6
PRG<k>_PRU<n>_GPI13	SD6_D	SD demodulator data channel 6
PRG<k>_PRU<n>_GPI14	SD7_CLK	SD demodulator clock channel 7
PRG<k>_PRU<n>_GPI15	SD7_D	SD demodulator data channel 7
PRG<k>_PRU<n>_GPI16	SD8_CLK	SD demodulator clock channel 8
PRG<k>_PRU<n>_GPI17	SD8_D	SD demodulator data channel 8
PRG<k>_PRU<n>_GPI18	-	
PRG<k>_PRU<n>_GPI19	-	

(1) Note: These signals are shared with the GP and Peripheral I/Fs. To configure for Sigma Delta, ICSSM_GPCFG0_REG[29-26] PR1_PRU0_GP_MUX_SEL (where k = 0 or 1 and n = 0 or 1) needs to be set to 3h for SD mode.

The PRG<k>_PRU0_GPI11 signal (muxed with SD0_D) can be used as SD_CLKOUT when PRU-ICSS generates clock. This is a trade-off as PRU application will lose one SD channel. SD_CLKOUT needs to go through a clock generator chip if driving multiple sigma delta modulators and also be looped back into PRU-ICSS as SD_CLKIN, typically pru_gpi16.

Note: To output the SD clock on PR<k>_PRU0_GPO1, this device requires that the PRU core be configured for both SD and shift out mode (ICSSM_GPCFG0_REG[29-26] PR1_PRU0_GP_MUX_SEL = 3h and ICSSM_GPCFG0_REG[14] PRU<n>_GPO_MODE = 1h). Be sure to configure the shift out mode's clock divisors before enabling shift out mode (ICSSM_GPCFG0_REG[14] PRU<n>_GPO_MODE = 1h). Additionally, the PRU-ICSS, PRU0 SD clock is routed to both PR0_PRU0_GPO1 and PR0_PRU1_GPO1. [Figure 7-29](#) shows a block diagram of the Sigma Delta implementation. Full description of the PRU R30 and R31 registers are shown in [Table 7-49](#) and [Table 7-50](#).

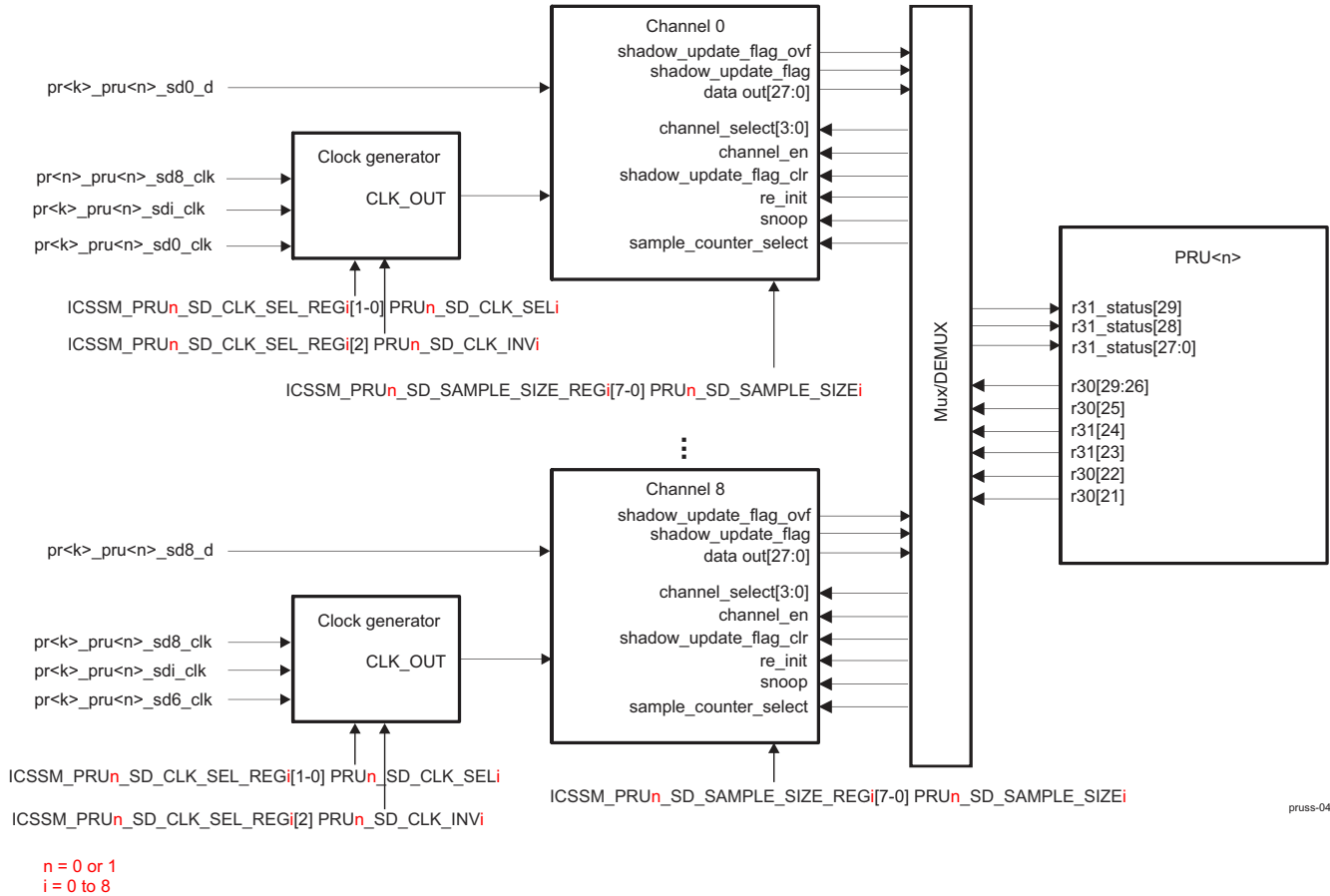

Figure 7-29. Sigma Delta Block Diagram

Note: Each channel can independently be configured to use one of three external clock sources. Table 7-48 shows the clock source options, selectable through ICSSM_PRU0_SD_CLK_SEL_REGi[1-0] PRU0_SD_CLK_SELi (where n = 0 or 1 and i = 0 to 8).

Table 7-48. Sigma Delta External Clock Sources

PRU0_SD_CLK_SELi value	Clock Source
0	pr<k>_pru<n>_sd8_clk
1	pr<k>_pru<n>_sd<i>_clk
2	pr<k>_pru<n>_sd0_clk for sd0, sd1, and sd2; pr<k>_pru<n>_sd3_clk for sd3, sd4, and sd5; pr<k>_pru<n>_sd6_clk for sd6, sd7, and sd8

7.2.5.2.2.3.5.2 PRU R30 / R31 Interface

The PRU uses the R30 and R31 registers to interface with the Sigma Delta interface. Table 7-49 and Table 7-50 shows the R31 and R30 interface for the Sigma Delta mode. Note that only the parameters and data for one channel can be viewed at a time. The channel to be viewed is determined by the r30[29-26] (channel_select).

Table 7-49. Sigma Delta PRU Registers: R31

Bits	Field Name	Description
31-30	Reserved	
29	shadow_update_flag_ovf	Shadow update flag overflow, set when over sample count equals over sample size and shadow_update_flag is still set. Set bit R31[24] to clear the flag.
28	shadow_update_flag	Shadow update flag, set when over sample count equals over sample size and shadow_update_flag is still set. Set bit R31[24] to clear the flag.

Table 7-49. Sigma Delta PRU Registers: R31 (continued)

Bits	Field Name	Description
27-0	data_out[27-0]/ shadow_update_flag_clr (R31[24]) / re_init (R31[23])	data_out[27] (read): most-significant bit of sample data shadow_update_flag_clr (write): re_init (write): Set to reset all counters, flags, and shadow copy. Updates over_sample_size based on the current ICSSM_PRU0_SD_SAMPLE_SIZE_REGi[7-0] register (where n = 0 or 1 and i = 0 to 8) on the selected channel. shadow_update_flag_clr (write): Set to clear shadow_update_flag and shadow_update_flag_ovf (if set).

Table 7-50. Sigma Delta PRU Registers: R30

Bits	Field Name	Description
31-30	Reserved	
29-26	channel_select[3-0]	Channel select ⁽¹⁾ 0h: Channel 0 ... 8h: Channel 8 9h: Reserved ... Fh: Reserved
25	channel_en	Global Channel enable (effects all 9 channels). 0h: All channels disabled. Counters/flags are cleared. 1h: All channels enabled.
24-23	Reserved	
22	snoop	Enable snoop (i.e. fetch data) on the selected channel. 0h: acc1/acc2/acc3 shadow copy 1h: current acc1/acc2/acc3
21	sample_counter_select	Read sample counter. 0h: Not selected 1h: Sample count selected
20-0	Reserved	

(1) If ICSSM_PRU0_SD_CFG_REG[8] SHARE_EN = 1, SD channels are shared between RTU, PRU, and TX_PRU, 3 channels per CPU.

The PRU-ICSS CFG register space has additional registers for controlling the SD demodulator module:

- ICSSM_PRU0_SD_CLK_SEL_REGi[5-4] PRU0_SD_ACC_SELi (where n = 0 or 1, i = 0 to 8) - Selects accumulator 1, 2 or 3 as source (acc1/acc2/acc3).
- ICSSM_PRU0_SD_CLK_SEL_REGi[2] PRU0_SD_CLK_INVi (where n = 0 or 1, i = 0 to 8) - Inverts clock.
- ICSSM_PRU0_SD_CLK_SEL_REGi[1-0] PRU0_SD_CLK_SELi (where n = 0 or 1, i = 0 to 8) - Selects the clock source.
- ICSSM_PRU0_SD_SAMPLE_SIZE_REGi[7-0] PRU0_SD_SAMPLE_SIZEi (where n = 0 or 1, i = 0 to 8) - Selects number of samples to read before giving output.

7.2.5.2.3.5.3 Sigma Delta Description

Figure 7-30 shows a block diagram of the Sigma Delta hardware integrators and integration with the PRU R30 / R31 interface for a single channel.

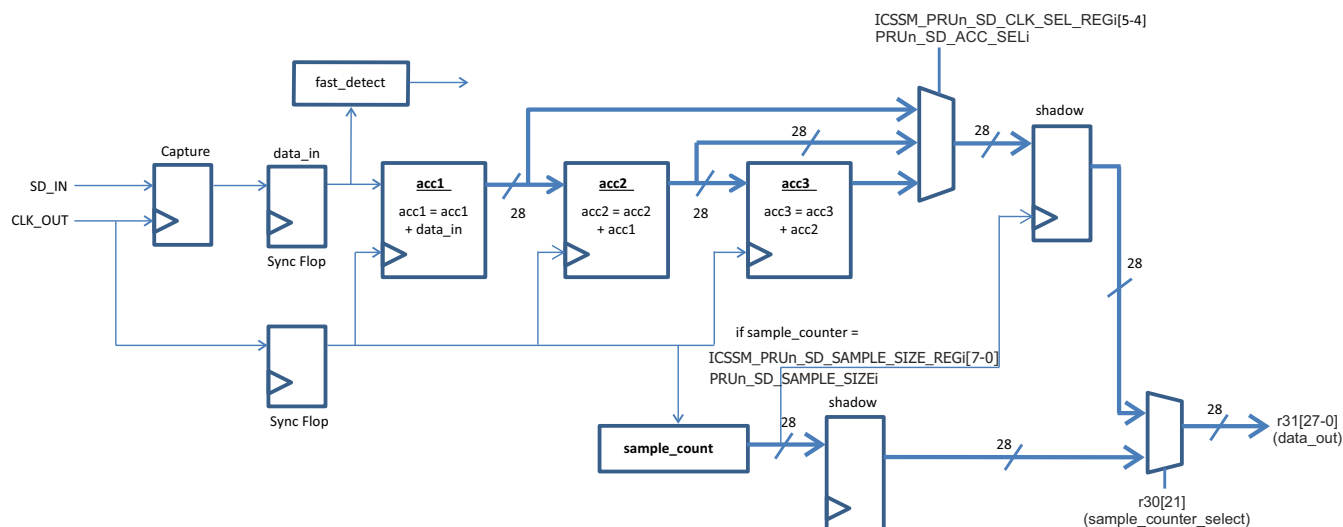

Figure 7-30. Sigma Delta Hardware Integrators Block Diagram (snoop = 0)

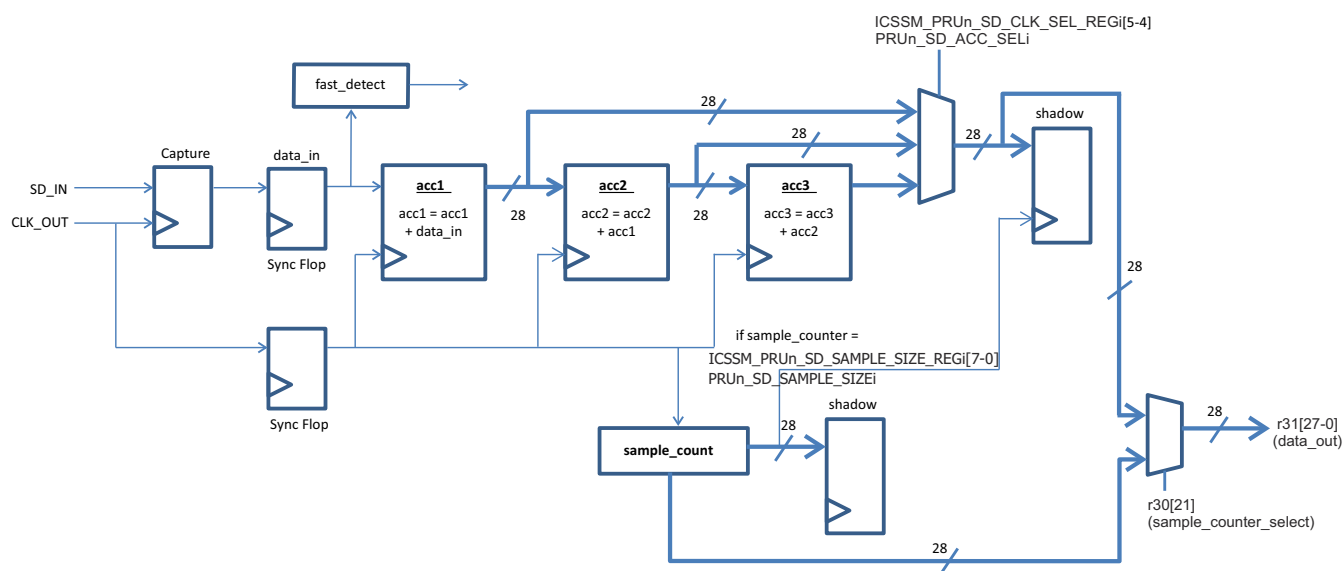

Figure 7-31. Sigma Delta Hardware Integrators Block Diagram (snoop = 1)

The three accumulators (acc1-acc3) for each channel are simple 28 bit adders. The input for acc1 is 1-bit, while the inputs for acc2 and acc3 are 28-bits. On each positive edge of the CLK_OUT, all three 28-bit counters (acc1-acc3) and the sample counter for each channel will get updated as follows:

```

acc1 = acc1 + data_in
acc2 = acc2 + acc1
acc3 = acc3 + acc2
sample_count = sample_count + 1

```

Each accumulator will rollover at 0xFF_FFFF. For example if acc2 = 0x10 and acc3 = 0xFF_FFFF, then acc3 will update to 0x00_0000F on the next clock event. Sample counter will rollover when it equals the defined sample size (ICSSM_PRU0_SD_SAMPLE_SIZE_REGi[7-0] PRU0_SD_SAMPLE_SIZEi).

Note that while the channels are not enabled, no operations are performed and all flags and counters are cleared. If a new sample size is to be loaded, the PRU firmware should assert re_init (r31[23]), and all stored count values are cleared to 0.

Fast detect block is used to detect fast changes in the amount of ones, presented in a programmable sliding window of 4 to 32 bits. The sliding window is controlled by ICSSM_PRU0_SD_SAMPLE_SIZE_REGi[10-8] PRU0_FD_WINDOW_SIZE_i bit field.

Fast detect must be enabled through the ICSSM_PRU0_SD_SAMPLE_SIZE_REGi[23] PRU0_FD_EN_i register before SD is enabled. It will start the compare after the first 32 sample clocks. Fast detect block will remain active until a re_init (r31[23]) is asserted.

The Sigma Delta interface has two status flags:

- Shadow update flag (r31[28])
- Shadow update flag overflow (r31[29])

When sample_counter equals the defined sample size (ICSSM_PRU0_SD_SAMPLE_SIZE_REGi[7-0] PRU0_SD_SAMPLE_SIZEi), then the acc1/acc2/acc3 shadow register copy will be updated, the shadow_update_flag (r31[28]) will be set, and sample_counter will rollover to 0. The PRU firmware can clear this flag by writing '1' to shadow_update_flag_clr (r31[28]). If sample_count equals the defined sample size and the shadow_update_flag is still set, then shadow_update_flag_ovf (r31[29]) will be set. Similarly, the PRU firmware can clear this flag by writing '1' to shadow_update_flag_ovf_clr (r31[29]). Note that the clear operation for both flags has a higher priority than the set event.

The PRU firmware can monitor the acc2/acc3 and sample_counter values through data_out[27-0] (r31[27-0]). [Table 7-51](#) shows the configuration options for data_out[27-0].

Table 7-51. Data_out[27-0] Configuration Options

snoop (r30[22])	sample_counter_select (r30[21])	data_out (r31[27-0])
0	0	Reads acc1/acc2/acc3 shadow register copy. See Figure 7-30 Sigma Delta Hardware Integrators Block Diagram (snoop = 0).
1	0	Reads acc1/acc2/acc3 directly. See Figure 7-31 Sigma Delta Hardware Integrators Block Diagram (snoop = 1).
0	1	Reads sample_counter shadow register copy. See Figure 7-30 Sigma Delta Hardware Integrators Block Diagram (snoop = 0).
1	1	Reads sample_counter directly. See Figure 7-31 Sigma Delta Hardware Integrators Block Diagram (snoop = 1).

7.2.5.2.2.3.5.4 Sigma Delta Basic Programming Example

The following programming example assumes that the PRU is configured for Sigma Delta Mode (**ICSSM_GPCFG0_REG[29-26] PR1_PRU<n>_GP_MUX_SEL = 3h**).

1. Configure clock sources, accumulator source, and sample size:
 - a. ICSSM_PRU0_SD_CLK_SEL_REGi[1-0] PRU0_SD_CLK_SELi (where n = 0 or 1, i = 0 to 8) for clock source
 - b. ICSSM_PRU0_SD_CLK_SEL_REGi[2] PRU0_SD_CLK_INVi (where n = 0 or 1, i = 0 to 8) for clock polarity
 - c. ICSSM_PRU0_SD_CLK_SEL_REGi[5-4] PRU0_SD_ACC_SELi (where n = 0 or 1, i = 0 to 8) - for accumulator source (acc1/acc2/acc3)
 - d. ICSSM_PRUSS_SD_PRU0_SAMPLE_SIZE_REGISTERi[7-0] PRU0_SD_SAMPLE_SIZE for sample size
2. Reinitialize all channels whose sample size was configured
 - a. Select channel by writing to channel_select (r30[29-26])
 - b. Delay at least 1 PRU cycle before executing re_int in step 2c.
 - c. Reinitialize selected channel by writing to re_init (r31[23])
 - d. Repeat steps 2a & 2b for all configured channels
3. Enable all channels by writing '1' to channel_en (r30[25])
4. Select channel by writing to channel_select (r30[29-26])

- a. Poll shadow_update_flag (r31[28]) to detect when acc1/acc2/acc3 shadow register copy data is ready to be read
 - b. Delay at least 1 PRU cycle before polling shadow_update_flag in Step 4c.
 - c. Read data_out[27-0] (r31[27-0])
 - d. Clear shadow_update_flag by writing '1' to r31[24]
5. Repeat step 4 for new channel

7.2.5.2.2.3.6 Three Channel Peripheral Interface

The 3 channel Peripheral Interface supports functionality for operations utilizing the EnDat 2.2 and BiSS protocols.

This module supports the following features:

- 3 channels with baud range from 100 kHz to 16 MHz
- ICSSM_UART_CLK (default) or ICSSM_ICLK controller clock is an input to independent div16fr clock dividers to produce a 1X clock (PERIF<m>_CLK) and oversampling clock
- Half-duplex (TX and RX are not supported concurrently)
- TX FIFO size of 32 bits
- RX FIFO size of 4 bits
- Configurable shift size/oversampling on RX
- Optional RX frame size auto shut off
- Programmable HW delay 1 (wire delay, controlling when the clock signal is first driven low) and delay 2 (tst delay, controlling when the clock signal is first driven high) on TX operation
- Optional programmable TX termination
- Individual TX channel start trigger (tx_channel_go) or simultaneous TX start trigger for all channels (tx_global_go)
- Flexible HW assisted clock output generation to allow free running, stop high and stop low (after last RX data), or stop high (after last TX data) operation with optional software clock override feature
- Optional SW direct snoop of data input
- RX Start Bit of '1' or '0'

7.2.5.2.2.3.6.1 Peripheral Interface Block Diagram and Signal Configuration

The Peripheral Interface's I/Os are multiplexed with the PRU GPI/GPO signals, as shown in [Table 7-52](#). The PR1_PRU<n>_GP_MUX_SEL bitfield in the ICSSM_GPCFG0_REG register (PRU0 or PRU1) must be set to 1h for configure the GPI/GPO signals for Peripheral I/F mode.

Table 7-52. PRU GPI/GPO Signals and Configurations for Peripheral I/F⁽¹⁾

Pad Names at Device Level ^{(2) (3)}	Peripheral I/F Mode (ICSSM_GPCFG0_REG[29-26] PR1_PRU0_GP_MUX_SEL = 1h)
PRG<k>_PRU<n>_GPI0	
PRG<k>_PRU<n>_GPI1	
PRG<k>_PRU<n>_GPI2	
PRG<k>_PRU<n>_GPI3	
PRG<k>_PRU<n>_GPI4	
PRG<k>_PRU<n>_GPI5	
PRG<k>_PRU<n>_GPI6	
PRG<k>_PRU<n>_GPI7	
PRG<k>_PRU<n>_GPI8	
PRG<k>_PRU<n>_GPI9	PERIF0_IN
PRG<k>_PRU<n>_GPI10	PERIF1_IN
PRG<k>_PRU<n>_GPI11	PERIF2_IN
PRG<k>_PRU<n>_GPI12	
PRG<k>_PRU<n>_GPI13	
PRG<k>_PRU<n>_GPI14	

Table 7-52. PRU GPI/GPO Signals and Configurations for Peripheral I/F⁽¹⁾
(continued)

Pad Names at Device Level ^{(2) (3)}	Peripheral I/F Mode (ICSSM_GPCFG0_REG[29-26] PR1_PRU0_GP_MUX_SEL = 1h)
PRG<k>_PRU<n>_GPI15	
PRG<k>_PRU<n>_GPI16	
PRG<k>_PRU<n>_GPI17	
PRG<k>_PRU<n>_GPI18	
PRG<k>_PRU<n>_GPI19	
PRG<k>_PRU<n>_GPO0	PERIF0_CLK
PRG<k>_PRU<n>_GPO1	PERIF0_OUT
PRG<k>_PRU<n>_GPO2	PERIF0_OUT_EN
PRG<k>_PRU<n>_GPO3	PERIF1_CLK
PRG<k>_PRU<n>_GPO4	PERIF1_OUT
PRG<k>_PRU<n>_GPO5	PERIF1_OUT_EN
PRG<k>_PRU<n>_GPO6	PERIF2_CLK
PRG<k>_PRU<n>_GPO7	PERIF2_OUT
PRG<k>_PRU<n>_GPO8	PERIF2_OUT_EN
PRG<k>_PRU<n>_GPO9	
PRG<k>_PRU<n>_GPO10	
PRG<k>_PRU<n>_GPO11	
PRG<k>_PRU<n>_GPO12	
PRG<k>_PRU<n>_GPO13	
PRG<k>_PRU<n>_GPO14	
PRG<k>_PRU<n>_GPO15	
PRG<k>_PRU<n>_GPO16	
PRG<k>_PRU<n>_GPO17	
PRG<k>_PRU<n>_GPO18	
PRG<k>_PRU<n>_GPO19	

- (1) Usage of the Peripheral Interface signals are not restricted to only ENDAT interfaces.
- (2) Note: These signals are shared with the GP, MII and Sigma Delta modes. To configure for Peripheral I/F, ICSSM_GPCFG0_REG[29-26] PR1_PRU0_GP_MUX_SEL needs to be set to 1h.
- (3) Some devices may not pin out all 29 bits of R31 and all 32 bits of R30. For which pins are available on this device, see *PRU-ICSS Environment*. See the device-specific Datasheet for device pin mapping.

A block diagram for the Peripheral I/F is included in [Figure 7-32](#). As shown, each channel is composed of four I/Os:

- PERIF<m>_IN - RX input data
- PERIF<m>_CLK - Clock (CLK_OUT) generated by the 1x (or TX) clock. The default value is 1.
- PERIF<m>_OUT - TX output data. The default value is 0.
- PERIF<m>_OUT_EN - TX enable output (1 = TX mode, 0 = RX mode). The default value is 0. Note: This signal is auto controlled by hardware.

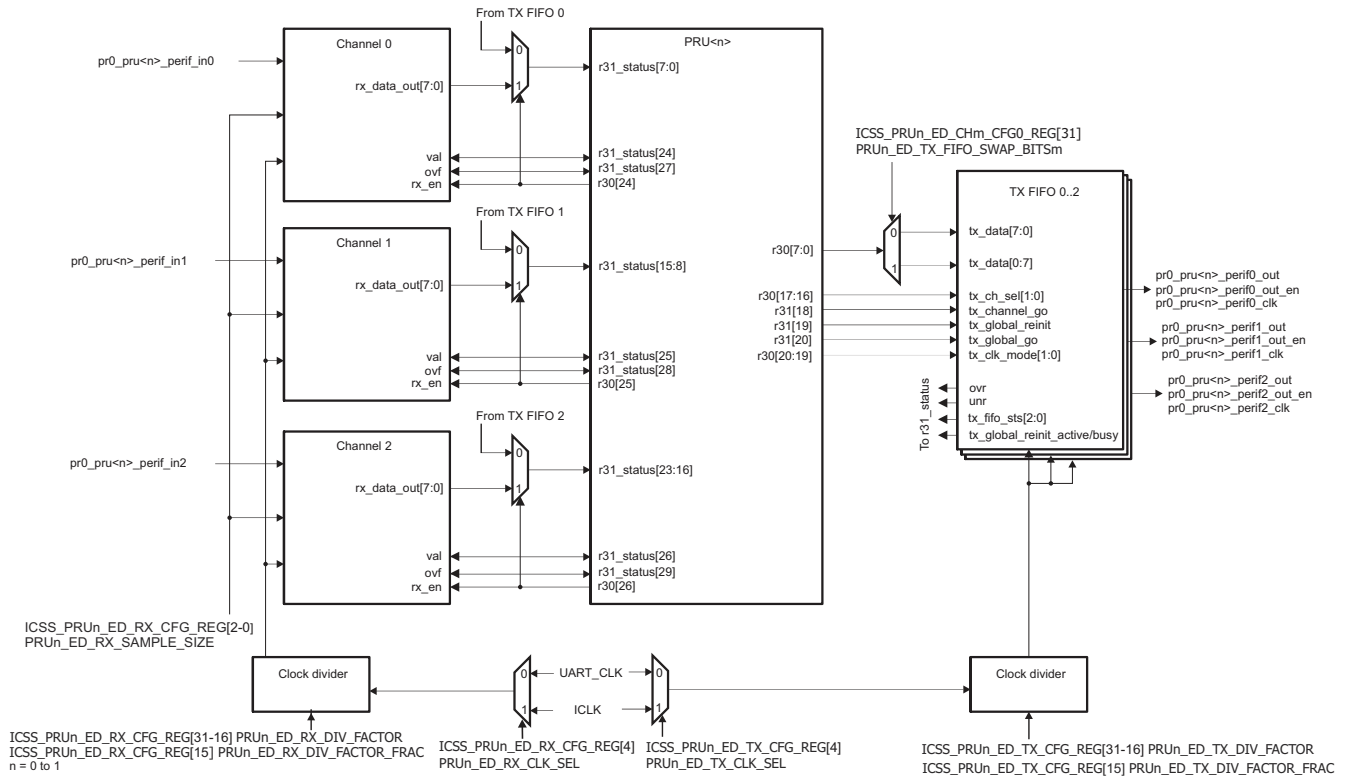

Figure 7-32. Peripheral I/F Block Diagram

7.2.5.2.2.3.6.2 PRU R30 and R31 Interface

The PRU uses the R30 and R31 registers to interface with the Peripheral I/F. Table 7-53 shows the R31 and R30 interface for the Peripheral I/F RX mode, and Table 7-54 shows the comparable interface for the TX mode.

Table 7-53. Peripheral I/F RX

Register	Bits	Field name	Description
R31	31-30	Reserved	PRU Host Interrupts 1/0 from local INTC
	29	ovf2	Overflow Flag for Channel 2. Write 1 to clear.
	28	ovf1	Overflow Flag for Channel 1. Write 1 to clear.
	27	ovf0	Overflow Flag for Channel 0. Write 1 to clear.
	26	val2	Valid Flag for Channel 2. Write 1 to clear.
	25	val1	Valid Flag for Channel 1. Write 1 to clear.
	24	val0	Valid Flag for Channel 0. Write 1 to clear.
	23-16	rx_data_out2	Oversampled Data Output for Channel 2. Note: These bits are shared with the TX Interface. When TX_FIFO has stopped transmission, RX data will be selected.
	15-8	rx_data_out1	Oversampled Data Output for Channel 1. Note: These bits are shared with the TX Interface. When TX_FIFO has stopped transmission, RX data will be selected.
7:0	rx_data_out0	Oversampled Data Output for Channel 0. Note: These bits are shared with the TX Interface. When TX_FIFO has stopped transmission, RX data will be selected.	

Table 7-53. Peripheral I/F RX (continued)

Register	Bits	Field name	Description
R30	31-27	Reserved	
	26	rx_en2	RX Enable for Channel 2. 0h: Channel not enabled, all counters/flags will get reset 1h: Channel is enabled
	25	rx_en1	RX Enable for Channel 1. 0h: Channel not enabled, all counters/flags will get reset 1h: Channel is enabled
	24	rx_en0	RX Enable for Channel 0. 0h: Channel not enabled, all counters/flags will get reset 1h: Channel is enabled
	23-0	Reserved	

Table 7-54. Peripheral I/F TX

Register	Bits	Field name	Description
R31	31-30	Reserved	
	29-22	Reserved	
	21	tx_global_reinit_active/ busy2	Tx_global_reinit action has some latency do to clocking. This status shows if action is completed. 1h: Active 0h: Done For non reinit case, this bit states that last bit is on tx wire. It does not mean the clock is off. 1h: Last bit is not done 0h: Last bit on tx wire Note that by using rx auto arm feature, the observation is lost at rx enable. This can be used to determine when to enable rx during non-auto arm case.
	20	tx_global_go	TX global start of all channels. Note: FIFO must not be empty. If empty, transmit will not start.
	19	tx_global_reinit	Reinit all channels into default mode. This clears all flags and state machines for all channels. Note: Sequence should be assert tx_global_reinit then de-assert rx_en. This will ensure TX and RX are in reset/default state. User must assert this after the frame has been sent and TX is not busy.
	18	tx_channel_go	TX start the channel transmit (selected by tx_ch_sel). Note: FIFO must not be empty.
	17	unr2	Under Run Flag for Channel 2. This flag is only set when the tx_frame_count is nonzero and FIFO is empty at time to send data.
	16	ovr2	Over Run Flag for Channel 2
	15-14	Reserved	
	13	tx_global_reinit_active/ busy1	Tx_global_reinit action has some latency do to clocking. This status shows if action is completed. 1h: Active 0h: Done For non reinit case, this bit states that last bit is on tx wire. It does not mean the clock is off. 1h: Last bit is not done 0h: Last bit on tx wire Note that by using rx auto arm feature, the observation is lost at rx enable. This can be used to determine when to enable rx during non-auto arm case.
	12-10	tx_fifo_sts1	TX FIFO occupancy status for Channel 1. 0 :0 Empty 1h: 1 word 2h: 2 words 3h: 3 words 4h: Full 5h-7h: Reserved
	9	unr1	Under Run Flag for Channel 1. This flag is only set when the tx_frame_count is nonzero and FIFO is empty at time to send data.
	8	ovr1	Over Run Flag for Channel 1
	7-6	Reserved	

Table 7-54. Peripheral I/F TX (continued)

Register	Bits	Field name	Description
R30	5	tx_global_reinit_active/ busy0	Tx_global_reinit action has some latency do to clocking. This status shows if action is completed. 1h: Active 0h: Done For non reinit case, this bit states that last bit is on tx wire. It does not mean the clock is off. 1h: Last bit is not done 0h: Last bit on tx wire Note that by using rx auto arm feature, the observation is lost at rx enable. This can be used to determine when to enable rx during non-auto arm case.
	4-2	tx_fifo_sts0	TX FIFO occupancy status for Channel 0. 0h: Empty 1h: 1 word 2h: 2 words 3h: 3 words 4h: Full 5h-7h: Reserved
	1	unr0	Under Run Flag for Channel 0. This flag is only set when the tx_frame_count is nonzero and FIFO is empty at time to send data.
	0	ovr0	Over Run Flag for Channel 0
	31-21	Reserved	
	20-19	clk_mode	CLK_OUT mode. 0h: Free-running/stop-low. Clock will remain free-running until the receive module has received the number of bits indicated in rx_frame_counter and then the clock will stop low. 1h: Free-running/stop-high (default). Clock will remain free-running until the receive module has received the number of bits indicated in rx_frame_counter and then the clock will stop high. Note: This is the default/reset state, and a hardware reset or reinit will return clk_mode to this state. Note: The initial state of the clock will be high, but the clock will not start until TX GO event. 2h: Free-run. NOTE: You must do a reinit to get out of this clock mode then you can update clk_mode to a different mode. Also if you do multiple TX GO, the 2nd go should have tst_delay and wire_delay zero since the clock is free running after the first go. 3h: Stop high after transmit. Clock will run until the last TX bit is sent and stops high.
	18	Reserved	
17-16	tx_ch_sel	TX channel select. 0h: Channel 0 1h: Channel 1 2h: Channel 2 3h: Reserved	
15-9	Reserved		
7-0	tx_data	TX data for FIFO. Notes: FIFO transmits MSB first and is 32-bits deep. TX_FIFO_SWAP_BITS bit in the PRU-ICSS CFG register space can be used to flip the load order of bits. The FIFO has 2 modes of operation: 1. Preload and Go. This should be done for EnDAT and frames less than 32-bits. 2. Continuous mode. This should be done for frames bigger than 32-bits. In continuous mode, software needs to keep up with the line rate and ensure that the FIFO is never empty. When the FIFO is at 2 byte level, software needs to load the next 2 bytes. If software waits till the end of the empty state, it is possible to get the TX into a bad state. The FIFO state can be recovered via re-init.	

Note

The PRU-ICSS CFG register space has additional registers for controlling the Peripheral I/F module.

7.2.5.2.3.6.3 Clock Generation

2.5.2.2.3.6.3.1 Configuration

The Peripheral I/F module has two source clock options, ICSSM_UART_CLK (default) and ICSSM_ICLK. There are two independent clock dividers (div16) for the 1x and oversampling (OS) clocks, and each clock divider is configurable by two cascading dividers:

- [31-16] PRU0_ED_TX_DIV_FACTOR and [15] PRU0_ED_TX_DIV_FACTOR_FRAC for the 1x clock
- [31-16] PRU0_ED_RX_DIV_FACTOR and [15] PRU0_ED_RX_DIV_FACTOR_FRAC for the OS clock

The 1x clock is output on the PERIF<m>_CLK signal. In TX mode, the output data is read from the TX FIFO at this 1x clock rate. The default value of this clock is high and the start and stop conditions for this clock are described in [Section 2.5.2.2.3.6.3.2 Clock Output Start Conditions](#) and [Section 2.5.2.2.3.6.3.3 Stop Conditions](#).

In RX mode, the input data is sampled at the OS clock rate. Note: The OS clock rate divided by the 1x clock rate must equal [2-0] PRU0_ED_RX_SAMPLE_SIZE.

Example clock rates and divisor values relative to the 192-MHz ICSSM_UART_CLK source are shown in [Table 7-55](#).

Table 7-55. Clock Rate Examples for 192-MHz PRUSSn_UART_GFCLK Clock Source

TX_DIV_FACTOR	1x Clock	RX_DIV_FACTOR	RX_DIV_FACTOR_FRAC	OS Clock	Oversample Factor
12	16 MHz	1	1.5	128 MHz	8x
16	12 MHz	2	1	96 MHz	8x
24	8 MHz	3	1	64 MHz	8x
32	6 MHz	4	1	48 MHz	8x
48	4 MHz	6	1	32 MHz	8x
96	2 MHz	12	1	16 MHz	8x
192	1 MHz	24	1	8 MHz	8x

2.5.2.2.3.6.3.2 Clock Output Start Conditions

This section describes the configurable start conditions for the PERIF<m>_CLK. The software can completely control via ICSSM_PRU0_ED_CHm_CFG0_REG when bit [29] PRU0_ED_CLK_OUT_OVR_ENm = 1h (where n = 0 or 1 and m = 0 to 2). By default however, the PRU hardware will control the clocks as described in the following sections.

2.5.2.2.3.6.3.2.1 TX Mode (RX_EN = 0)

In TX mode, the PERIF<m>_CLK begins after the firmware loads the TX FIFO and sets either r31[20] (tx_global_go) or r30[17-16] (tx_channel_go) to 1h. After the “go” bit is set, the delay1 (wire delay) compensation counter for each channel begins. After delay1 is complete, PERIF<m>_CLK is driven low and then the delay2 (tst) counter begins. After the delay2 counter expires, the PERIF<m>_CLK starts running (first low and then high). Therefore, first rising edge of PERIF<m>_CLK (measured from the go bit) = delay1 (tx wire delay) + delay2 (tst_counter delay) + half of the 1x clock frequency (since the clock starts low).

[Figure 7-33](#) shows the start condition for TX mode. As shown in the figure, the default value of clock is high. The PRU-ICSS CFG register space has additional registers for controlling the TX start timing delay values:

- Delay 1: ICSSM_PRU0_ED_CHm_CFG0_REG[10-0] PRU0_ED_TX_WDLYm (where n = 0 or 1 and m = 0 to 2)
- Delay 2: ICSSM_PRU0_ED_CHm_CFG1_REG[15-0] PRU0_ED_TST_DELAY_COUNTERm (where n = 0 or 1 and m = 0 to 2)

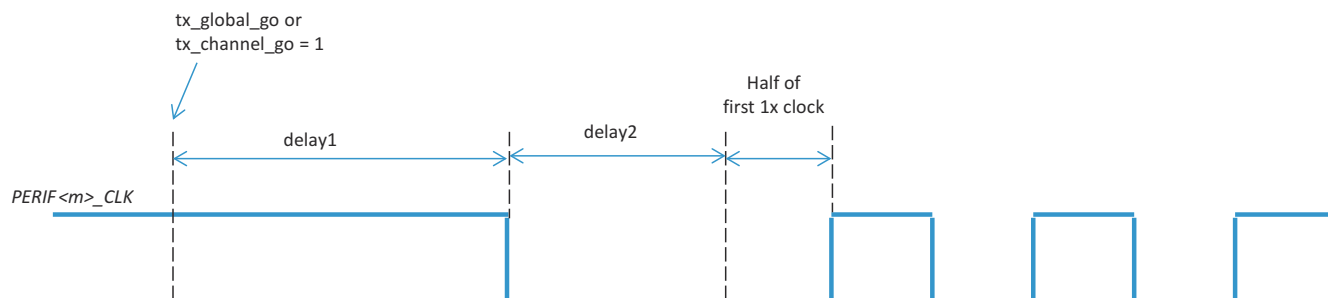

Figure 7-33. TX Mode Start Condition

5.2.2.3.6.3.2.2 RX Mode (RX_EN = 1)

In RX mode, the PERIF<m>_CLK will start running whenever the RX_EN is set. Note that the PRU firmware in this mode is responsible for any delay conditions.

The hardware can also auto-enable RX mode at the end of a TX transaction. The ICSSM_PRU0_ED_CHm_CFG1_REG[31-16] PRU0_ED_RX_EN_COUNTERm (where n = 0 or 1 and m = 0 to 2) is used to program a delay between the last TX bit sent and when the RX_EN is set.

2.5.2.2.3.6.3.3 Stop Conditions

The r30[20-19] (clk_mode[1:0]) value determines the stop condition for PERIF<m>_CLK. There are 4 options available:

clk_mode_value	Description
0	Stop low on last RX frame
1	Stop high on last RX frame
2	Run continuously
3	Stop high on last TX bit

The last RX frame is configured by ICSSM_PRU0_ED_CHm_CFG0_REG[27-16] PRU0_ED_RX_FRAME_SIZE_m, and the last TX bit is configured by ICSSM_PRU0_ED_CHm_CFG0_REG[15-11] PRU0_ED_TX_FRAME_SIZE_m (where n = 0 or 1 and m = 0 to 2). Each stop condition is shown in [Figure 7-34](#) through [Figure 7-37](#).

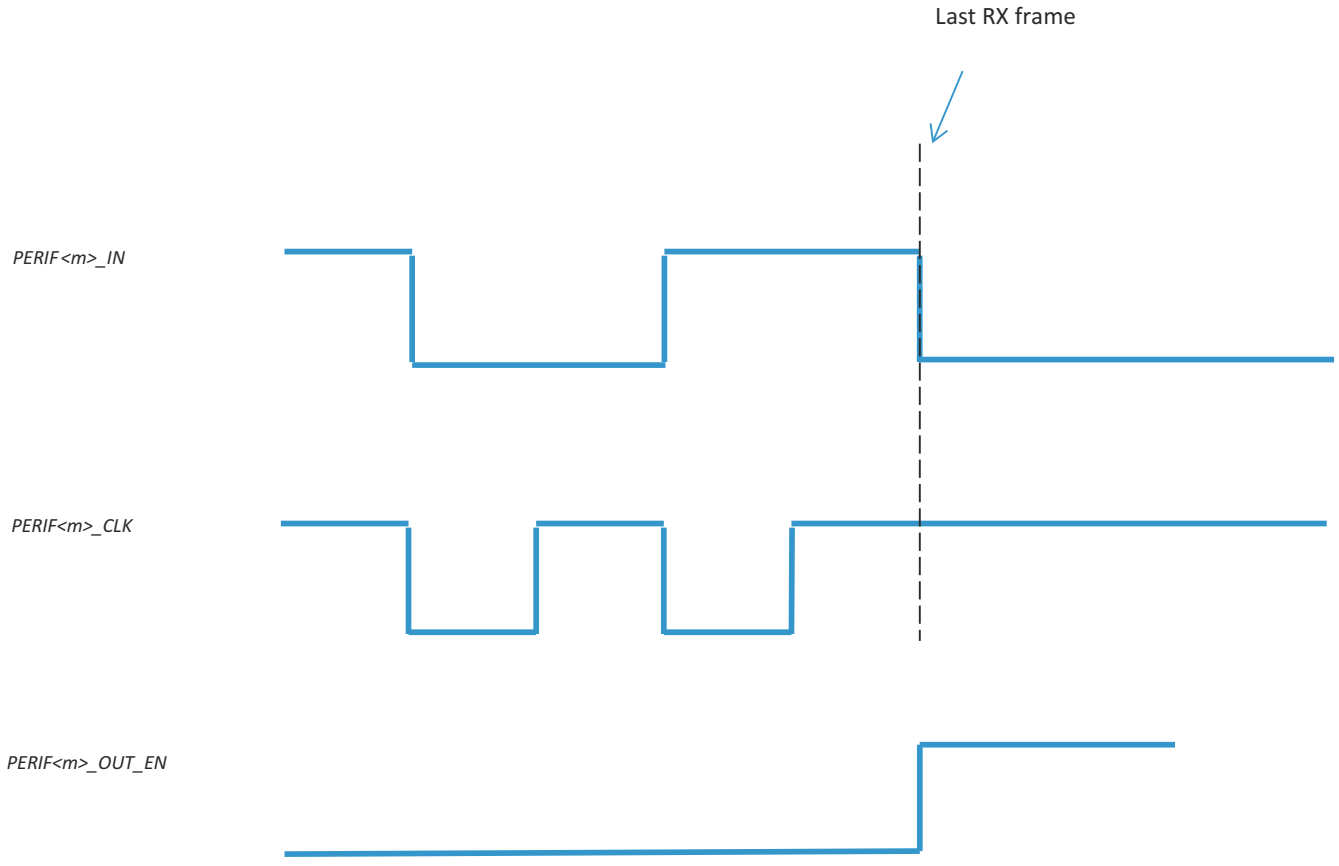

Figure 7-34. PERIF<m>_CLK Stop High on Last RX Frame

ADVANCE INFORMATION

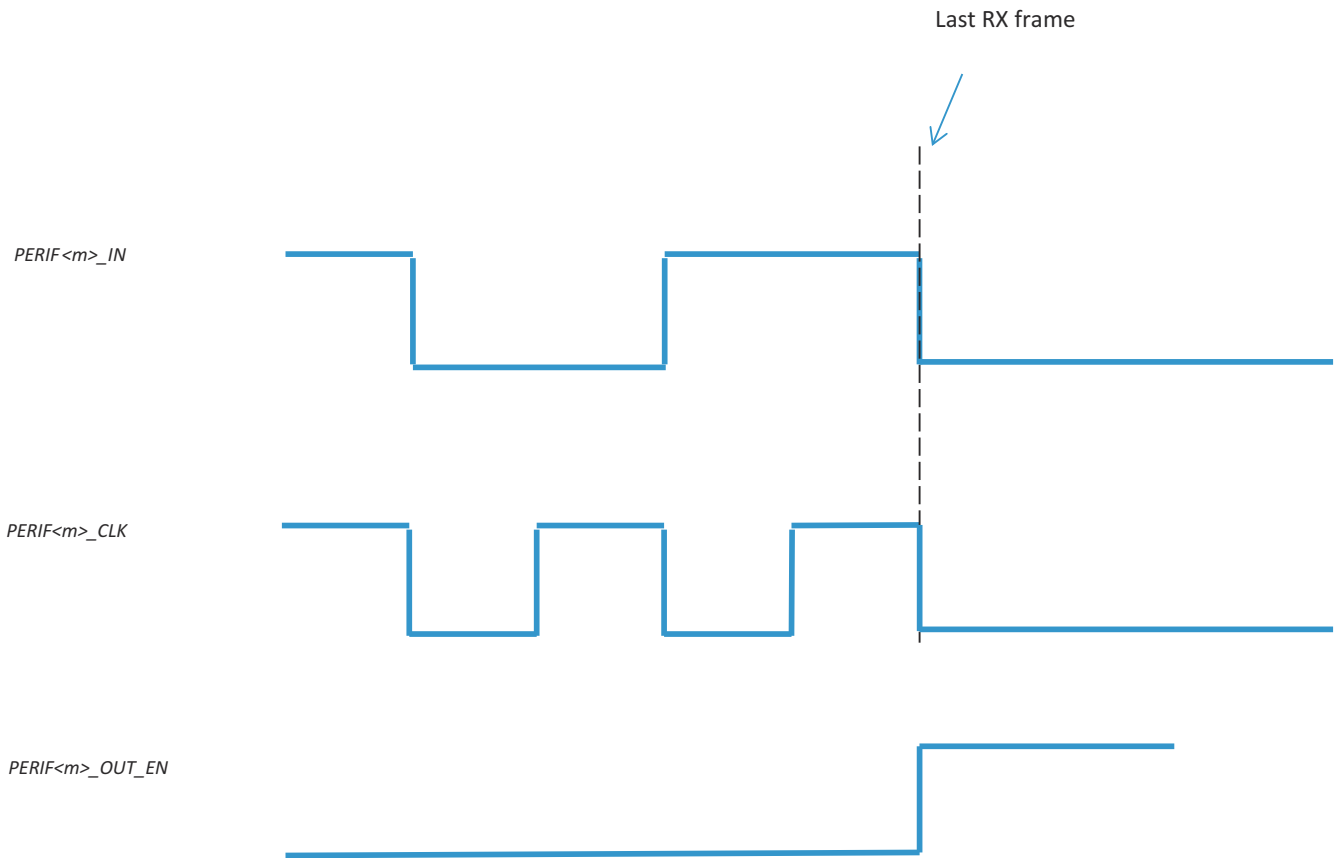

Figure 7-35. PERIF<m>_CLK Stop Low on Last RX Frame

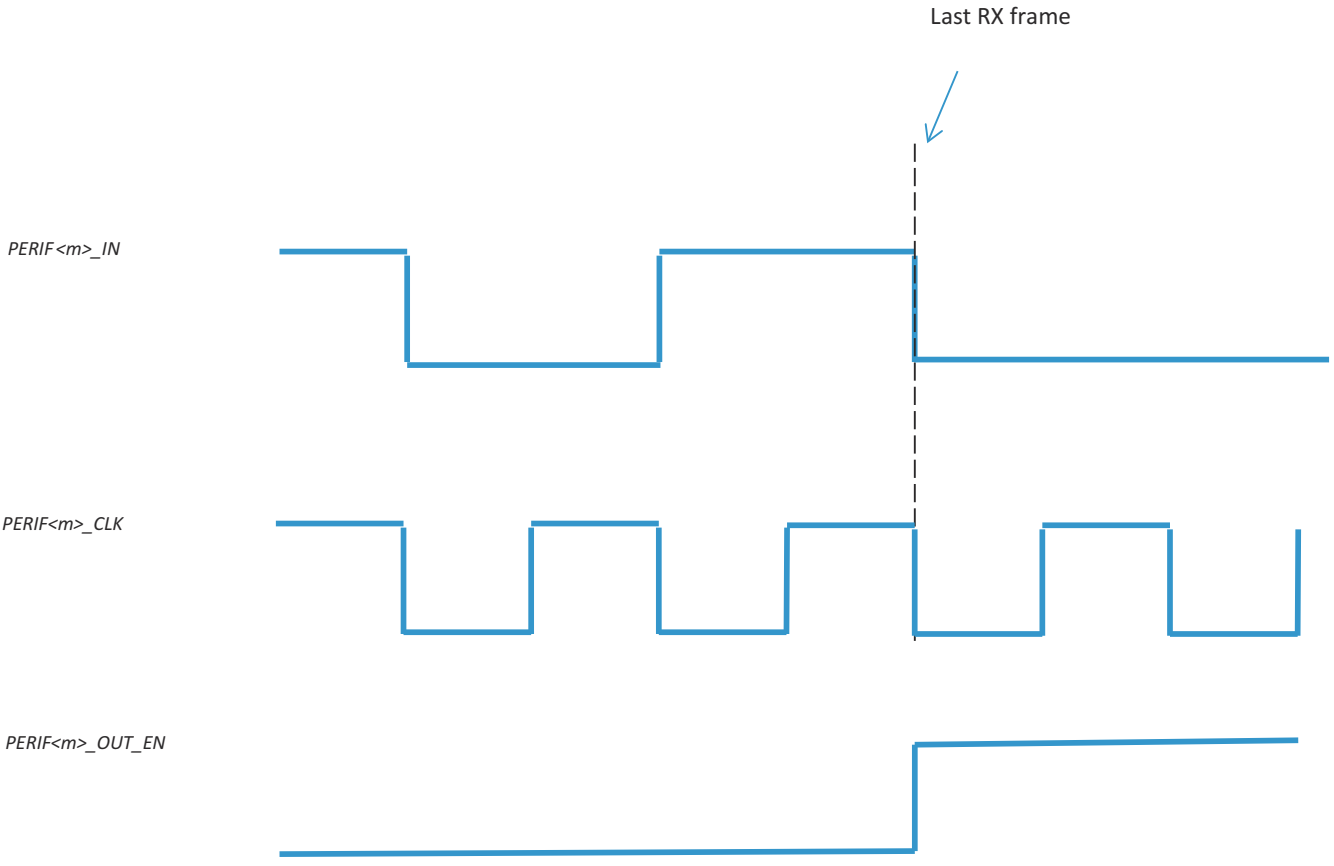

Figure 7-36. PERIF<m>_CLK Run Continuously

ADVANCE INFORMATION

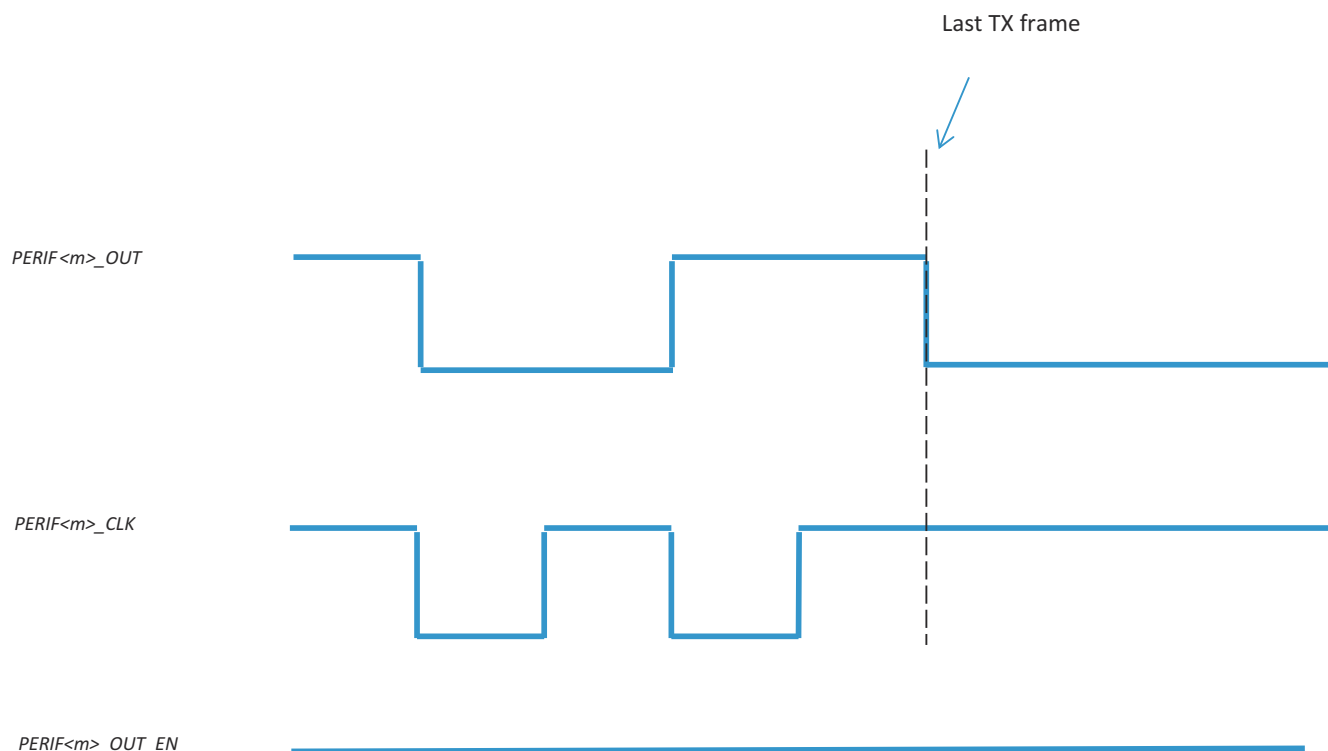

Figure 7-37. PERIF<m>_CLK Stop High on Last TX Bit

7.2.5.2.2.3.6.4 Three Peripheral Mode Basic Programming Model

The following programming models assume that the PRU is configured for 3 Peripheral Mode (ICSSM_GPCFG0_REG[29-26] PR1_PRU0_GP_MUX_SEL = 1h).

2.5.2.2.3.6.4.1 Clock Generation

Follow these steps to configure Peripheral I/F clocks using the HW control of the clock:

1. Select TX and RX clock sources:
 - a. ICSSM_PRU0_ED_TX_CFG_REG[4] PRU0_ED_TX_CLK_SEL for the TX clock source
 - b. ICSSM_PRU0_ED_RX_CFG_REG[4] PRU0_ED_RX_CLK_SEL for the RX clock source
2. Configure the 1x (TX) clock frequency:
 - a. Write Division Factor to ICSSM_PRU0_ED_TX_CFG_REG[31-16] PRU0_ED_TX_DIV_FACTOR
 - b. Write Fraction division factor to ICSSM_PRU0_ED_TX_CFG_REGISTER[15] PRU0_ED_TX_DIV_FACTOR_FRAC
3. Configure the oversampling (RX) frequency and oversample size:
 - a. Write Division Factor to ICSSM_PRU0_ED_RX_CFG_REG[31-16] PRU0_ED_RX_DIV_FACTOR
 - b. Write Fraction division factor to ICSSM_PRU0_ED_RX_CFG_REG[15] PRU0_ED_RX_DIV_FACTOR_FRAC
 - c. Write RX oversample size to ICSSM_PRU0_ED_RX_CFG_REG[2-0] PRU0_ED_RX_SAMPLE_SIZE
4. Select the clk_mode to configure how the PERIF<m>_CLK signal ends after TX/RX:
 - a. Write to r30[20-19] (clk_mode). Note: The clk_mode setting can also be changed per transaction.
5. Configure the wire, tst, and rx_en_counter delay values:
 - a. ICSSM_PRU0_ED_CHm_CFG0_REG[10-0] PRU0_ED_TX_WDLYm for wire delay (where n = 0 or 1 and m = 0 to 2)
 - b. ICSSM_PRU0_ED_CHm_CFG1_REG[15-0] PRU0_ED_TST_DELAY_COUNTERm for tst delay (where n = 0 or 1 and m = 0 to 2)

- c. ICSSM_PRUSS_ED_PRU0_CHm_CFG1_REG[31-16] PRU0_ED_RX_EN_COUNTER for auto-delay between TX and RX (where $n = 0$ or 1 and $m = 0$ to 2)

2.5.2.2.3.6.4.2 TX - Single Shot

Follow these steps to configure the Peripheral I/F channel(s) for a single shot transmission:

1. (Optional) Configure TX FIFO for MSB (default) or LSB:
 - a. ICSSM_PRU0_ED_CHm_CFG0_REG[31] PRU0_ED_TX_FIFO_SWAP_BITSm (where $n = 0$ or 1 and $m = 0$ to 2)
2. Pre-load TX FIFO:
 - a. Select TX channel by writing the desired channel number to R30[17-16] (tx_ch_sel)
 - b. Write 1-4 bytes of data to r30[7-0] (tx_data). At each r30[7-0] write, data will be pushed into the FIFO.
 - c. Repeat Steps 2a and 2b for all desired channels.
3. Configure TX frame size if less than 4 full bytes loaded into FIFO:
 - a. ICSSM_PRU0_ED_CHm_CFG0_REG[15-11] PRU0_ED_TX_FRAME_SIZE_m (where $n = 0$ or 1 and $m = 0$ to 2)
4. Push TX FIFO data to PERIFm_OUT (see [Section 2.5.2.2.3.6.3.2](#) for the PERIFm_CLK and PERIFm_OUT start time relationship):
 - a. To start TX on all channels, set r31[20] = 1 (tx_global_go).
 - b. To start TX on individual channel:
 - i. Select TX channel by writing the desired channel number to R30[17-16] (tx_ch_sel)
 - ii. Set R31[18] = 1 (tx_channel_go)
5. If ICSSM_PRU0_ED_CHm_CFG1_REG[31-16] PRU0_ED_RX_EN_COUNTER_m > 0 (where $n = 0$ or 1 and $m = 0$ to 2), then the channel will automatically switch into RX mode. See [Section 2.5.2.2.3.6.4.4](#) for an example of how to program and configure RX content.
6. If ICSSM_PRU0_ED_CHm_CFG1_REG[31-16] PRU0_ED_RX_EN_COUNTER_m = 0, poll either r31[21, 13, or 5] (tx_global_reinit_active/busy[2,1,0]) or [7, 6, or 5] PRU0_ED_BUSY_m (where $m = 0$ to 2 , indicates channel number) for when TX is complete

Note

The PERIFm_CLK Peripheral I/F requires that PERIFm_CLK be in a high state at the beginning of a new transaction. If the clock ended the single shot transmission in low state, then the clock needs to be reset before sending more data. The steps to reset PERIFm_CLK are:

1. Set R31[19] = 1 (tx_global_reinit) to reset clock high
2. Wait until PRU0_ED_BUSY_m bit is cleared
3. Re-configure R30[20-19] (clk_mode), since reinit will reset the clk_mode to "Free-running/stop-high" mode

2.5.2.2.3.6.4.3 TX - Continuous FIFO Loading

Follow these steps to configure the Peripheral I/F channel(s) for a continuous loading transmission:

1. (Optional) Configure TX FIFO for MSB (default) or LSB:
 - a. ICSSM_PRU0_ED_CHm_CFG0_REG[31] PRU0_ED_TX_FIFO_SWAP_BITSm
2. Pre-load TX FIFO:
 - a. Select TX channel by writing the desired channel number to r30[17-16] (tx_ch_sel)
 - b. Write 1-4 bytes of data to r30[7-0] (tx_data). At each r30[7-0] write, data will be pushed into the FIFO.
 - c. Repeat Steps 2a and 2b for all desired channels.
3. Configure TX frame size to continuously transmit the TX FIFO until empty:
 - a. Set ICSSM_PRU0_ED_CHm_CFG0_REG[15-11] PRU0_ED_TX_FRAME_SIZE_m = 0h
4. Push TX FIFO data to PERIFm_OUT (see [Section 2.5.2.2.3.6.3.2](#) for the PERIFm_CLK and PERIFm_OUT start time relationship):
 - a. To start TX on all channels, set r31[20] = 1 (tx_global_go).
 - b. To start TX on individual channel:

- i. Select TX channel by writing the desired channel number to r30[17-16] (tx_ch_sel)
 - ii. Set r31[18] = 1 (tx_channel_go)
5. Monitor line rate and reload FIFO:
 - a. Polling r31[xx, 12-10, 4-2] (tx_fifo_sts<m>)
 - b. When FIFO level is at 2 bytes, load next 2 bytes of data (see Step 2). Do not let the FIFO get close to 0. Once the FIFO runs empty, the hardware will assume the PRU has reached end of the last transmit. Any new writes to the FIFO will NOT be sent until the software sends another tx_channel_go bit. Note: There are also underrun and overrun error flags that can be monitored.
6. To end TX operation, do not send any new data to FIFO.
 - a. If ICSSM_PRU0_ED_CHm_CFG1_REG[31-16] PRU0_ED_RX_EN_COUNTERm > 0 (where n = 0 or 1 and m = 0 to 2), then the channel will automatically switch into RX mode. See [Section 2.5.2.2.3.6.4.4](#) for an example of how to program and configure RX content.
 - b. If ICSSM_PRU0_ED_CHm_CFG1_REG[31-16] PRU0_ED_RX_EN_COUNTERm = 0, poll either r31[21, 13, or 5] (tx_global_reinit_active/busy[2,1,0]) or ICSSM_PRU0_ED_TX_CFG_REG[7, 6, or 5] PRU0_ED_BUSY_m (where m = 0 to 2, indicates channel number) for when TX is complete

Note

The PERIF<m>_CLK Peripheral I/F requires that PERIF<m>_CLK be in a high state at the beginning of a new transaction. If the clock ended the continuous loading transmission in low state, then the clock needs to be reset before sending more data. The steps to reset PERIF<m>_CLK are:

1. Set R31[19] = 1 (tx_global_reinit) to reset clock high
 2. Wait until PRU0_ED_BUSY_m is cleared
 3. Re-configure R30[20-19] (clk_mode), since reinit will reset the clk_mode to "Free-running/stop-high" mode
-

2.5.2.2.3.6.4.4 RX - Auto Arm or Non-Auto Arm

Follow these steps to configure the Peripheral I/F channel(s) to receive data:

1. Configure RX and frame size:
 - a. ICSSM_PRU0_ED_CHm_CFG0_REG[27-16] PRU0_ED_RX_FRAME_SIZE_m (where n = 0 or 1 and m = 0 to 2)
2. Configure start bit polarity:
 - a. ICSSM_PRU0_ED_RX_CFG_REG[3] RX_SB_POL (PRU0 or PRU1)
 - b. For the non-auto arm use case, set r30[26, 25, 24] = 1 (rx_en<m>)
 - c. For the auto arm use case, rx_en<m> will be automatically enabled at the end of a TX operation when ICSSM_PRU0_ED_CHm_CFG1_REG[31-16] PRU0_ED_RX_EN_COUNTERm > 0 (where n = 0 or 1 and m = 0 to 2)
3. RX FIFO will start filling on the first start bit (PERIF<m>_IN = 1). The data will be captured on the positive edge of the PERIF<m>_CLK and shifted into the LSB position of the 8-bit shadow register.
4. Poll for r31[26, 25, 24] (val<m>) assertion. The valid flag will be asserted when n bits of data (determined by ICSSM_PRU0_ED_RX_CFG_REG[2-0] PRU0_ED_RX_SAMPLE_SIZE) have been collected.
5. Fetch data by reading r31[23-16, 15-8, 7-0] (rx_data_out<m>). The data will remain constant for one data frame, and PRU must read data and clear valid flag within this time. Otherwise, an overflow will occur – r31[29, 28, 27] (ovf<m>) = 1 - indicating that val<m> has been continuously asserted for longer than one data frame.
6. The clock will be stopped based on the r30[20-19] (clk_mode) configured before the start of the RX operation.
7. Clear r30[26, 25, 24] (rx_en<m>) to disable RX mode. All counters and flags will be reset.

7.2.5.3 PRU-ICSS RAM Index Allocation

The PRU-ICSS module includes integrated ECC Aggregator module to test ECC functionality.

[Table 7-56](#) shows the mapping of the RAM IDs to the ECC RAMs serviced by the ECC Aggregator.

Table 7-56. Mapping of the RAM IDs to the ECC RAMs

RAM Index	ECC RAM Prefix	Description
0	pr<k>_dram0	Data RAM0 (8KB)
1	pr<k>_dram1	Data RAM1 (8KB)
2	pr<k>_pru0_iram	PRU0 Instruction Memory (12KB)
3	pr<k>_pru1_iram	PRU1 Instruction Memory (12KB)
4	pr<k>_ram	Shared Data RAM2 (64KB)

7.2.6 PRU-ICSS Broadside Accelerators

7.2.6.1 PRU-ICSS Broadside Accelerators Overview

The PRU-ICSS supports a broadside interface, which uses the XFR (XIN, XOUT, or XCHG) instruction to transfer the contents of PRUn (where n = 0 or 1) registers to or from accelerators. This interface enables up to 31 registers (R0-R30, or 124 bytes) to be transferred in a single instruction. This section details the various accelerators that are available to the PRUn through the broadside interface.

Each of those functions have a unique XIN ID to determine which operation will occur. For more information see [Table 7-33](#).

7.2.6.2 PRU-ICSS Data Processing Accelerators Functional

7.2.6.2.1 PRU Multiplier with Accumulation (MPY/MAC)

This section describes the MAC (multiplier with accumulation) module integrated to PRU0/PRU1 cores.

Each of the two PRU cores (PRU0/PRU1) has a designated unsigned multiplier with accumulation (MPY/MAC). The MAC supports two modes of operation: Multiply Only and Multiply and Accumulate.

The MAC is directly connected with the PRU internal registers R25-R29 and uses the broadside load/store PRU interface and XFR instructions to both control and mode of the MAC and import the multiplication results into the PRU.

The PRU MPY/MAC features are:

- Configurable Multiply Only and Multiply and Accumulate functionality via PRU register R25
- 32-bit operands with direct connection to PRU registers R28 and R29
- 64-bit result (with carry flag) with direct connection to PRU registers R26 and R27
- One clock cycle per operation
- PRU broadside interface and XFR instructions (XIN, XOUT) allow for importing multiplication results and initiating accumulate function

7.2.6.2.1.1 PRU MAC Operations

7.2.6.2.1.1.1 PRU versus MAC Interface

The MAC directly connects with the PRU internal registers R25-R29 through use of the PRU broadside interface and XFR instructions. [Figure 7-38](#) shows the functionality of each register.

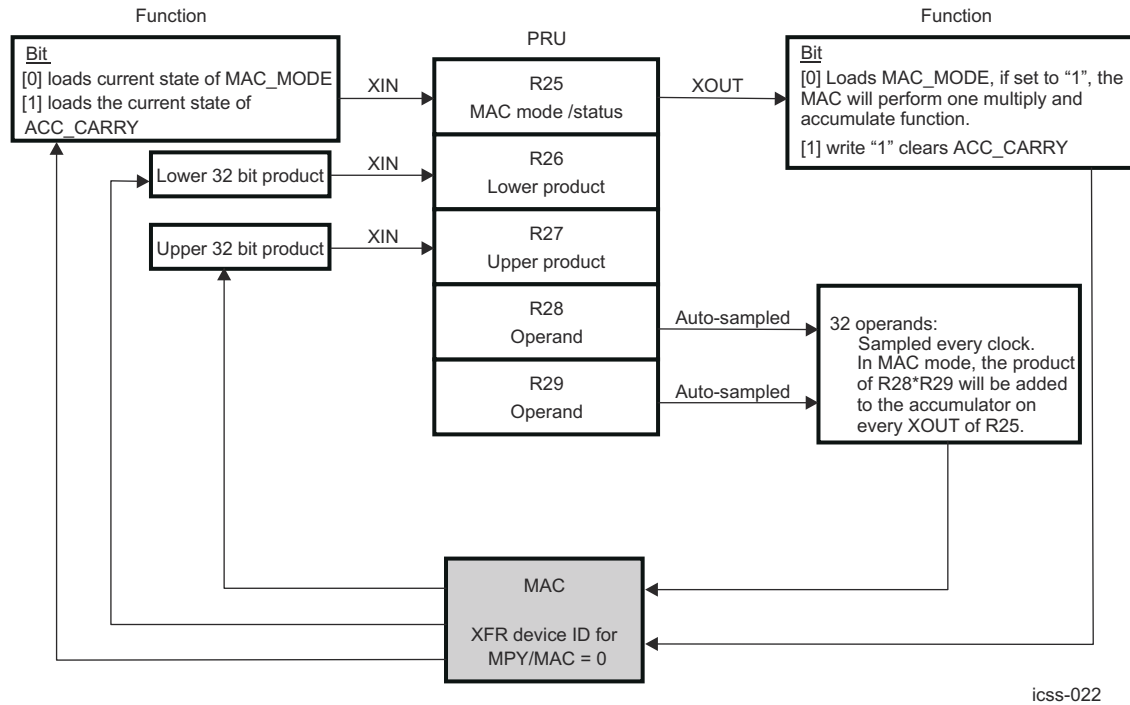

icss-022

Figure 7-38. Integration of the PRU and MPY/MAC

The XFR instructions (XIN and XOUT) are used to load/store register contents between the PRU core and the MAC. These instructions define the start, size, direction of the operation, and device ID. The device ID number corresponding to the MPY/MAC is shown in Table 7-57.

Table 7-57. MPY/MAC XFR ID

Device ID	Function
0	Selects MPY/MAC

The PRU register R25 is mapped to the MAC_CTRL_STATUS register (Table 7-58). The MAC's current status (MAC_MODE and ACC_CARRY states) is loaded into R25 using the XIN command on R25. The PRU sets the MAC's mode and clears the ACC_CARRY using the XOUT command on R25.

Table 7-58. MAC_CTRL_STATUS Register (R25) Field Descriptions

Bit	Field	Description
7-2	RESERVED	Reserved
1	ACC_CARRY	Write 1 to clear. It is sticky. It is set 0 cycles after the event. 0h: 64-bit accumulator carry has not occurred 1h: 64-bit accumulator carry occurred
0	MAC_MODE	0h: Accumulation mode disabled and accumulator is cleared 1h: Accumulation mode enabled

The two 32-bit operands for the multiplication are loaded into R28 and R29. These registers have a direction connection with the MAC. Therefore, XOUT is not required to load the MAC. In multiply mode, the MAC samples these registers every clock cycle. In multiply and accumulate mode, the MAC samples these registers every XOUT R25[7-0] transaction when MAC_MODE = 1.

The product from the MAC is linked to R26 (lower 32 bits) and R27 (upper 32 bits). The product is loaded into register R26 and R27 using XIN.

7.2.6.2.1.1.2 Multiply only mode(default state), MAC_MODE = 0

The [Figure 7-39](#) summarizes the MAC operation in "Multiply-only" mode, in which the MAC multiplies the contents of R28 and R29 on every clock cycle.

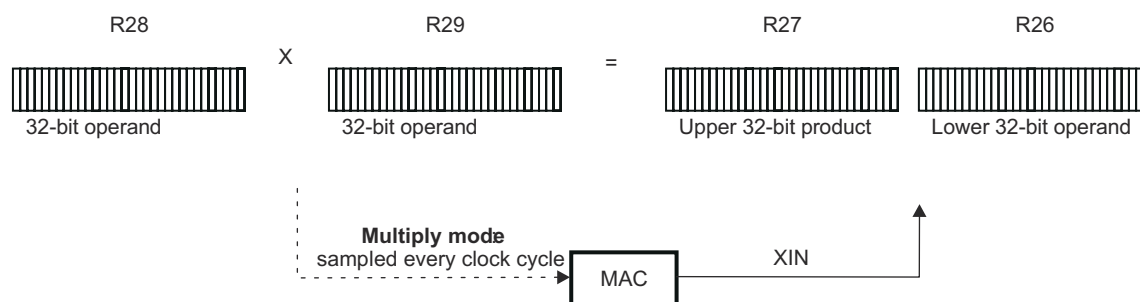

icss-023

Figure 7-39. MAC Multiply-only Mode- Functional Diagram

7.2.6.2.1.1.2.1 Programming PRU MAC in "Multiply-ONLY" mode

The following steps are performed by the PRU firmware for multiply-only mode:

1. 1. Enable multiply only MAC_MODE.
 - a. (a) Clear R25[0] for multiply only mode.
 - b. (b) Store MAC_MODE to MAC using XOUT instruction with the following parameters:
 - Device ID = 0
 - Base register = R25
 - Size = 1
2. 2. Load operands into R28 and R29.
3. 3. Delay at least 1 PRU cycle before executing XIN in step 4.
4. 4. Load product into PRU using XIN instruction on R26, R27.

Repeat steps 2 and 4 for each new operand.

7.2.6.2.1.1.3 Multiply and Accumulate Mode, MAC_MODE = 1

The [Figure 7-40](#) summarizes the MAC operation in "Multiply and Accumulate" mode. On every XOUT R25_REG[7-0] transaction, the MAC multiplies the contents of R28 and R29, adds the product to its accumulated result, and sets ACC_CARRY if an accumulation overflow occurs.

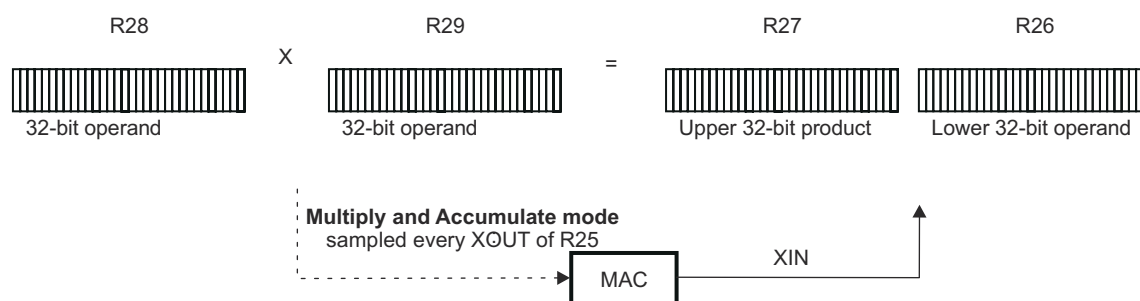

icss-024

Figure 7-40. MAC Multiply and Accumulate Mode Functional Diagram

7.2.6.2.1.1.3.1 Programming PRU MAC in Multiply and Accumulate Mode

The following steps are performed by the PRU firmware for multiply and accumulate mode:

1. Enable multiply and accumulate MAC_MODE.
 - (a) Set R25[1-0] = 1 for accumulate mode.

(b) Store MAC_MODE to MAC using XOUT instruction with the following parameters:

- Device ID = 0
- Base register = R25
- Size = 1

2. Clear accumulator and carry flag.

(a) Set R25[1-0] = 3 to clear accumulator (R25[1]=1) and preserve accumulate mode (R25[0]=1).

(b) Store accumulator to MAC using XOUT instruction on R25.

3. Load operands into R28 and R29.

4. Multiply and accumulate, XOUT R25[1-0] = 1

Repeat step 4 for each multiply and accumulate using same operands.

Repeat step 3 and 4 for each multiply and accumulate for new operands.

5. Load the accumulated product into R26, R27, and the ACC_CARRY status into R25 using the XIN instruction.

1.

Note

Steps one and two are required to set the accumulator mode and clear the accumulator and carry flag.

7.2.6.2.2 PRU CRC16/32 Module

Each of the PRU0/PRU1 cores have a designated CRC16/32 module.

In general, CRC adds error detection capability to communication systems. The CRC encoder appends redundant bits (or CRC bits) to the systematic data message. During reception of the data message, the received data is also encoded with the same CRC encoder. The 2 sets of CRC bits are compared together. If they match, there were no transmission errors; and if they don't match, a transmission error has been detected.

CRC16/32 supports the following features:

- Supports CRC32:
 - $x^{32}+x^{26}+x^{23}+x^{22}+x^{16}+x^{12}+x^{11}+x^{10}+x^8+x^7+x^5+x^4+x^2+x+1$
- Supports CRC16:
 - $x^{16}+x^{15}+x^2+1$
- Supports CRC16 - CCITT:
 - $x^{16}+x^{12}+x^5+1$
- PRU broadside interface and XFR instructions (XIN, XOUT) allow for importing CRC results and executing accumulate function

7.2.6.2.2.1 PRU and CRC16/32 Interface

The CRC16/32 module directly connects with the PRU internal registers R25-R29 through use of the PRU broadside interface and XFR instructions. [Table 7-59](#) shows the functionality of each register.

The XFR instructions (XIN/XOUT/XCHG) are used to load/store register contents between the PRU core and the CRC16/32 module. These instructions define the start, size, direction of the operation, and device ID. The XFR device ID number corresponding to the CRC16/32 module is 1.

Table 7-59. CRC Register to PRU Port Mapping

CRC Register	R/W	Description	PRU Mapping
CRC_CFG	W	Always write all 4 bytes. bit [0] CRC32_ENABLE: 0: CRC16 mode is selected. Hardware will auto-set init state of CRC_SEED to 0000_0000h. However, for CRC16-CCITT software will need to write the init state of FFFF_FFFFh to CRC_SEED. Note: The CRC16 result value is only 16-bits. 1: CRC32 mode is selected. Hardware will auto-set init state of CRC_SEED will be FFFF_FFFFh. bit [1] CRC_32B_NOT_EMPTY: 0: CRC 32Byte buffer is empty 1: CRC 32Byte buffer is not empty bit [2] CRC16_MOD_ENABLE: 0: CRC16 ($x^{16}+x^{15}+x^2+1$) 1: CRC16-CCITT ($x^{16}+x^{12}+x^5+1$) - Note: CRC32_ENABLE field must = 0.	R25
CRC_DATA_8_BFLIP	R	8-bit flip of CRC_DATA. CRC_DATA_8_BFLIP has the same byte order as CRC_DATA[31-0], but each byte has all bits flipped. CRC_DATA_32_FLIP[7-0] = CRC_DATA[0-7] CRC_DATA_32_FLIP[15-8] = CRC_DATA[8-15] CRC_DATA_32_FLIP[23-16] = CRC_DATA[16-23] CRC_DATA_32_FLIP[31-24] = CRC_DATA[24-31] For CRC16, only CRC_DATA_8_BFLIP[15-0] are valid. No auto reset on CRC_DATA_8_BFLIP read.	R27
CRC_SEED	W	CRC SEED value. Hardware will auto-initialize the CRC_SEED value to 0000_0000h for CRC16 and FFFF_FFFFh for CRC32. Software only needs to initialize CRC_SEED if a different default value is required. For CRC16-CCITT, software needs to update initial CRC_SEED value to FFFF_FFFFh. Always write 4 bytes. Note: Reading the CRC_DATA register will reset the CRC value to the CRC_SEED state.	R28

Table 7-59. CRC Register to PRU Port Mapping (continued)

CRC Register	R/W	Description	PRU Mapping
CRC_DATA_32_BFLIP	R	Full 32-bit flip of CRC_DATA CRC_DATA_32_BFLIP[0] = CRC_DATA[31] ... CRC_DATA_32_BFLIP[31] = CRC_DATA[0] For CRC16, only CRC_DATA_32_BFLIP[31-16] are valid. No auto reset on CRC_DATA_32_BFLIP read.	R28
CRC_DATA	RW	For Write, must use a fixed width throughout the session. The CRC module supports lower 8-bit, or lower 16-bit, or full 32-bit data widths. For Read, LSB or CRC_DATA[0] is first bit on the wire. For Read, reset the CRC_DATA back to CRC_SEED state. Note: Firmware must add 1 to 2 NOPs after the last XOUT to the XIN. For CRC16, only CRC_DATA[15-0] is valid.	R29

7.2.6.2.2.2 CRC Programming Model

The following steps are performed by the PRU firmware to use the CRC module:

Step1: Configuration (optional)

- Configure CRC type:
For CRC32 operation, set CRC32_ENABLE using XOUT instruction with the following parameters:
 - Device ID = 1
 - Base register = R25
 - Size = 1
- Update CRC_SEED, if required using XOUT with the following parameters:
 - Device ID = 1
 - Base register = R28
 - Size = 1 to 4

Step 2:

- Load new CRC data into R29
- Push CRC data to the CRC16/32 module using XOUT with the following parameters:
 - Device ID = 1
 - Base register = R29
 - Size = 1 to 4
- 1 or 2 NOPS
- Load the accumulated CRC result into the PRU using the XIN instruction with the following parameters:
 - Device ID = 1
 - Base register = R29
 - Size = 4

Repeat Step 2, numbers 1 and 2 for each new CRC data.

Note

When a session starts, the PRU firmware must use the same write data width throughout the session.

7.2.6.2.2.3 PRU and CRC16/32 Interface (R9:R2)

The PRU-ICSS system implements a new wide 32-Bytes data path. The firmware can perform one XOUT of 32-Bytes, the hardware will feed the CRC16/32 4-Bytes at a time. This will take 20 clock cycles for CRC16 and 12 clock cycles for CRC32 for a 32-Bytes XOUT.

Table 7-60. PRU Register to XFR Mapping

PRU Register	XFR ID	Domain/Function	Description
R9:R2 Data	1	Data	XOUT Only 1-Byte to 32-Bytes in size LSB packed and no gaps, for example:

Table 7-60. PRU Register to XFR Mapping (continued)

PRU Register	XFR ID	Domain/Function	Description
			32-Bytes push R9:R2
			16-Bytes push R5:R2
			4-Bytes push R2
			7-Bytes push R3(b2.b0):R2
			1-Bytes push R2(b0)

7.2.6.2.3 PRU-ICSS Scratch Pad Memory

The PRU-ICSS supports a scratch pad with up to four independent banks accessible by the PRU cores. The PRU cores interact with the scratch pad through broadside load/store PRU interface and XFR instructions. The scratch pad can be used as a temporary place holder for the register contents of the PRU.

7.2.6.2.3.1 PRU0/1 Scratch Pad Overview

The PRU-ICSS scratch pad supports the following features:

- PRU0 and PRU1 cores have three Scratch Pad banks of 30, 32-bit registers (R29 to R0)
- Flexible load/store options:
 - Load/store one byte of R<n> or load/store (R29 to R0) to Bank0, Bank1, Bank2 or Bank3
 - User-defined start byte and length of the transfer
 - Length of transfer ranges from one byte of a register to the entire register content (R29 to R0)
 - Simultaneous transaction supported between PRU0 <-> Bank<n> and PRU1 <-> Bank<m>
- XFR (XIN/XOUT/XCHG) instructions operate in one clock cycle
- Optional XIN/XOUT shift functionality allows remapping of registers (R<n> -> R<m>) during load store operation

Figure 7-41 shows a simplified model of the Scratch Pad and PRU cores integration.

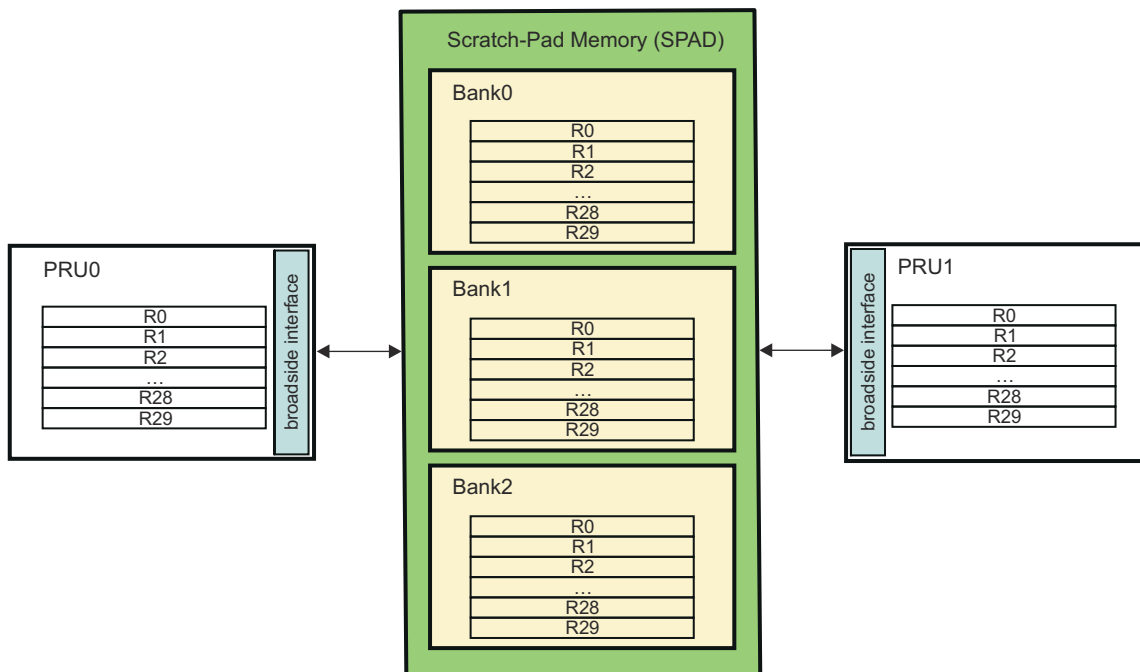

icss-025

Figure 7-41. Scratch Pad and PRU Integration

7.2.6.2.3.2 PRU0 /1 Scratch Pad Operations

XFR instructions are used to load/store register contents between the PRU cores and the scratch pad banks. These instructions define the start, size, direction of the operation, and device ID. The device ID corresponds to the external source or destination (either a scratch pad bank or the other PRU core). The device ID numbers are shown in Table 7-61.

Table 7-61. Scratch Pad XFR ID

Device ID	Function/Operation
10	Selects Bank0
11	Selects Bank1

Table 7-61. Scratch Pad XFR ID (continued)

Device ID	Function/Operation
12	Selects Bank2

A collision occurs when two XOUT commands simultaneously access the same asset or device ID. [Table 7-62](#) shows the priority assigned to each operation when a collision occurs.

Table 7-62. Scratch Pad XFR Collision and Stall Conditions

Operation	Collision and Stall Handling
PRU<n> XOUT (->) bank[j]	If both PRU cores access the same bank simultaneously, PRU0 is given priority. PRU1 will temporarily stall until the PRU0 operation completes.

7.2.6.2.3.2.1 Optional XIN/XOUT Shift

The optional XIN/XOUT shift functionality allows register contents to be remapped or shifted within the destination's register space. For example, the contents of PRU0 R6-R8 could be remapped to Bank1 R10-12.

The shift feature is enabled or disabled through the PRU subsystem level register ICSSM_SPP_REG[1] XFR_SHIFT_EN bit. When enabled, R0[4-0] (internal to the PRU) defines the number of 32-bit registers in which content is shifted in the scratch pad bank. Note that scratch pad banks do not have registers R30 or R31.

7.2.6.2.3.2.2 Scratch Pad Operations Examples

The following PRU firmware examples demonstrate the shift functionality. Note: These assume the XFR_SHIFT_EN bit of the ICSSM_SPP_REG register of the PRU-ICSS CFG register space has been set.

XOUT Shift By 4 Registers

Store R4:R7 to R8:R11 in Bank0:

- Load 4 into R0.b0
- XOUT using the following parameters:
 - Device ID = 10
 - Base register = R4
 - Size = 16

XOUT Shift By 9 Registers, With Wrap Around

Store R25:R29 to R4:R9 in Bank1:

- Load 9 into R0.b0
- XOUT using the following parameters:
 - Device ID = 11
 - Base register = R25
 - Size = 20

XIN Shift By 10 Registers

Load R14:R16 from Bank2 to R4:R6:

- Load 10 into R0.b0
- XIN using the following parameters:
 - Device ID = 12
 - Base register = R4
 - Size = 12

7.2.6.3 PRU-ICSS Data Movement Accelerators Functional

7.2.6.3.1 PRU-ICSS XFR2VBUS Hardware Accelerator

The PRU core can write and read data packets to and from port queues, located in the MSMC SRAM into PRU core registers via XFR2VBUS hardware accelerator. Each of the PRU-ICSS Slices has implemented two RX XFR2VBUS hardware accelerators.

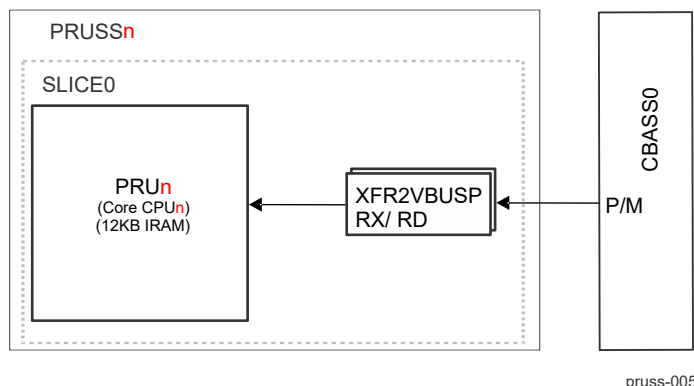

1. n represents a valid instance of PRU in a domain.

Figure 7-42. XFR2VBUS Hardware Accelerator

Supported features:

- 2 x XFR2VBUS RX threads

XFR2VBUS RX buffer features:

- 1 x 64 Byte deep RX/Read buffer
 - 4 Byte, 32 Byte, or 64 Byte read size per RD (read) command
 - Optional automatic read command with incrementing address on pop of read data
 - 32 Byte optimization mode available

The ownership of commands and data is flexible. The XFR2VBUS accelerator is shared between PRU cores. Status is available to both cores.

Note: The ownership should be preplanned and static per use model.

The XFR2VBUS is a simple hardware accelerator which is used to get the lowest read round trip latency from MSMC and to decouple the latency seen by the PRU. Each XFR2VBUS instance is connected to the CBASS0.

The PRU-ICSS system has a total of 2 XFR2VBUS RX hardware accelerators.

7.2.6.3.1.1 Blocking Conditions

The only blocking condition is caused when the VBUSM command/data FIFO is full. It is required that the external bandwidth is very high. All egress commands and data should get sent without head of line blocking. Based on arbitration some delay is possible.

7.2.6.3.1.2 Read Operation with Auto Disabled

The XFR2VBUS supports 1 command in its command FIFO, 1 XOUT to define the address and size (4 Byte, 32 Byte, 64 Byte, aligned). This will cause the VBUSP read command to be issued. Only 1 read command can be in flight. The read address defines the offset of the 64 Byte of read data. The read size defines the size of the transfer, 4 Byte, 32 Byte, 64 Byte, aligned. Offset + size must be aligned to 32 Byte width of the bus. 1 XIN, the software can see the status of command FIFO and read data FIFO.

Note: XIN of the read data will fully pop the data, independent of XIN size.

7.2.6.3.1.3 Read Operation with Auto Enabled

The same features as Auto Disabled are valid with the following exceptions:

64 Byte mode:

- Address needs to be MOD 0x40/64 Byte aligned
- Size needs to be 64 Byte
- 1 XOUT to define the start address, which needs to be MOD 0x40/64 Byte aligned
- The XFR2VBUS will issue 1 new command every time this is 64 Bytes available in the read data FIFO
- 1 XIN of read data will cause a new command to be issued since, 64 Bytes are available

- To stop the issuing new read commands, disable auto mode

32 Byte mode:

- Size needs to be 32 Byte
- 1 XOUT to define the start address, which needs to be MOD 0x20/32 Byte aligned
- The XFR2VBUS will issue 1 new command every time this is 32 Bytes available in the read data FIFO
- 1 XIN of read data will cause a new command to be issued since, 32 Bytes are available
- To stop the issuing of new read command, disable auto mode

Note: XIN of the read data will fully pop the data, independent of XIN size.

7.2.6.3.1.4 PRU to XFR2VBUS Interface

RD_ID0 = 0x60

RD_ID1 = 0x61

Table 7-63. Read Commands

PRU Register	BS ID	Access Type	Register	Notes
R17-R2	RD_ID1/0	XIN	RD_DATA	Read Data
R18[0]	RD_ID1/0	XOUT	RD_AUTO	Read Auto Mode If 0 -> 1, must write RD_ADDR If 1 -> 0, must not write RD_ADDR, must drain RD_DATA/RD_CMD If 0 -> 0, must write RD_ADDR When set, every RD_DATA pop will cause a new read command and read address to increment by 0x20 for the next read command if size is set to 32 Bytes 0x40 for the next read command if size is set to 64 Bytes In this case, user must set the address to be either mod 0x20 or 0x40. 4 Byte mode is not supported.
R18[2-1]	RD_ID1/0	XOUT	RD_SIZE	Read Size 0h: 4 Bytes 1h: Reserved 2h: 32 Bytes 3h: 64 Bytes
R18[0]	RD_ID1/0	XIN	RD_BUSY	Read Busy Status 0h: Idle 1h: Active (RD CMD FIFO LEVEL !=0) or (RD DATA FIFO LEVEL !=0)
R18[1]	RD_ID1/0	XIN	RD_CMD_FL	Read command FIFO Level 0h: Empty 1h: Occupied Note: It only pop the read command FIFO after the read data has arrived
R18[2]	RD_ID1/0	XIN	RD_DATA_FL	Read data FIFO Level 0h: Empty 1h: Occupied 32 byte or 64 byte Note: In 64 byte mode, the user must wait for RD_MST_REQ = 0h before reading the FIFO.

Table 7-63. Read Commands (continued)

PRU Register	BS ID	Access Type	Register	Notes
R18[3]	RD_ID1/0	XIN	RD_MST_REQ	RD MST RED 0h = Last data has been latched 1h = Last data is still in flight Note: In Auto mode, the user must insure that this bit is 0h and wait an additional NOP before user disables Auto mode to prevent a race condition.
R20:R19	RD_ID1/0	XOUT	RD_ADDR	Read address 48-bits 0x20 for the next read command if size is set to 32 Bytes 0x40 for the next read command if size is set to 64 Bytes The address can be the full 48-bits or just the lower 32-bits of the address, it will use the current state of the upper 16-bits

7.2.6.3.1.5 XFR2VBUS Programming Model

Read:

- Wait RD_BUSY = 0h
- XOUT R18 (configure RD_AUTO/ RD_SIZE); R19 (RD_ADDR)
- Wait WR_BUSY = 0h OR RD_DATA_FL = 1h
- XIN RD_DATA (Repeat if RD_AUTO is enabled and need new RD_DATA, must always check RD_DATA_FL before XIN RD_DATA)

7.2.7 PRU-ICSS Local INTC

The PRU-ICSS interrupt controller (INTC) maps interrupts coming from different parts of the device (mapped to PRU_ICSSM) to a reduced set of PRU-ICSS interrupt channels.

The interrupt controller has the following features:

- Capturing up to 64 System Events (inputs):
- Supports up to 10 output interrupt channels.
- Generation of 10 Host Interrupts
 - 2 Host Interrupts shared between the PRUs (PRU0 and PRU1).
 - 8 Host Interrupts exported from the PRU-ICSS internal INTC for signaling the device level interrupt controllers (pulse and level provided).
- Each event can be enabled and disabled.
- Each host event can be enabled and disabled.
- Hardware prioritization of events.

7.2.7.1 PRU-ICSS Interrupt Controller Functional Description

The PRU-ICSS INTC supports up to 64 interrupts from different peripherals and PRUs. The INTC maps these events to 10 channels inside the INTC (see Figure 7-43). Interrupts from these 10 channels are further mapped to 10 Host Interrupts.

- Any of the 64 internal interrupts can be mapped to any of the 10 channels.
- Multiple interrupts can be mapped to a single channel.
- An interrupt should not be mapped to more than one channel.
- Any of the 10 channels can be mapped to any of the 10 host interrupts. It is recommended to map channel “x” to host interrupt “x”, where x is from 0 to 9.
- A channel should not be mapped to more than one host interrupt
- For channels mapping to the same host interrupt, lower number channels have higher priority.
- For interrupts on same channel, priority is determined by the hardware interrupt number. The lower the interrupt number, the higher the priority.
- Host Interrupt 0 is connected to bit 30 in register 31 (R31) of PRU0 and PRU1 in parallel.
- Host Interrupt 1 is connected to bit 31 in register 31 (R31) for PRU0 and PRU1 in parallel.
- Host Interrupts 2 through 9 exported from PRU-ICSS and mapped to device level interrupt controllers.

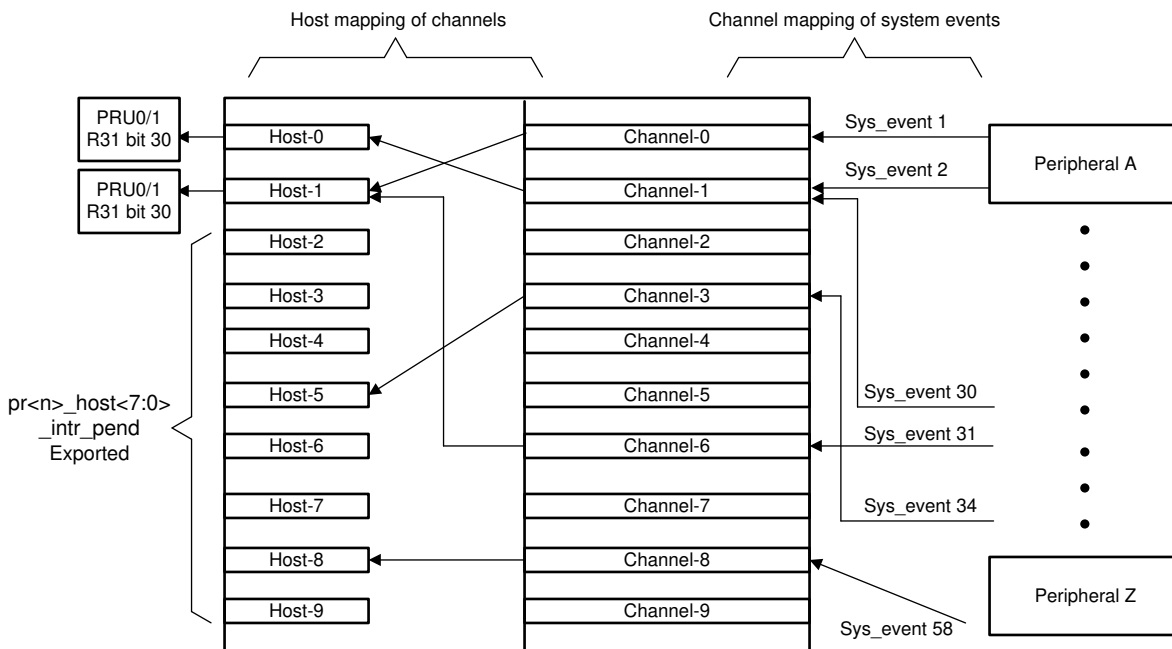

Figure 7-43. PRU-ICSS Interrupt Controller Block Diagram

7.2.7.1.1 PRU-ICSS Interrupt Controller Events

All PRU-ICSS system events are interrupt inputs. System events 32 through 63 are external and generated from different peripherals. System events 0 through 31 are internal for PRU-ICSS sources.

7.2.7.1.2 PRU-ICSS Interrupt Controller System Events Flow

The ICSS_INTC module controls the event mapping to the host interrupt interface. Events are generated by the device peripherals or PRUs. The INTC receives the internal interrupts and maps them to internal channels. The channels are used to group interrupts together and to prioritize them. These channels are then mapped onto the host interrupts. Interrupts from the system side are active high in polarity.

The INTC encompasses many functions to process the system interrupts and prepare them for the host interface. These functions are: processing, enabling, status, channel mapping, host interrupt mapping, prioritization, and host interfacing. Figure 7-44 illustrates the flow of interrupts through the functions to the host. The following subsections describe each part of the flow.

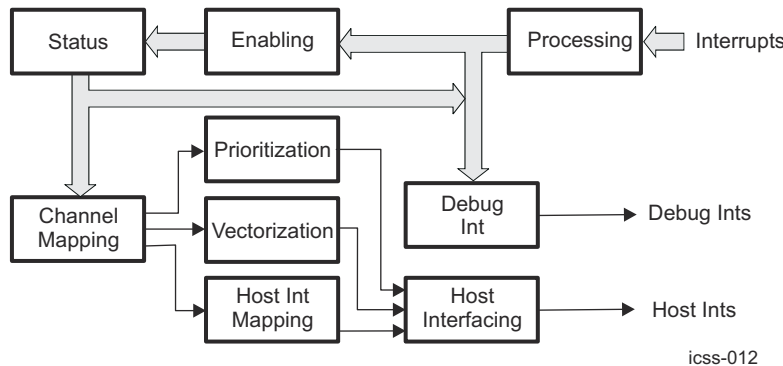

Figure 7-44. Flow of System Interrupts to Host

7.2.7.1.2.1 PRU-ICSS Interrupt Processing

This block does following tasks:

- Synchronization of slower and asynchronous interrupts
- Conversion of polarity to active high
- Conversion of interrupt type to pulse interrupts

After the processing block, all interrupts will be active high pulses.

7.2.7.1.2.1.1 PRU-ICSS Interrupt Enabling

The next stage of INTC is to enable interrupts based on programmed settings. The following sequence has to be followed to enable interrupts:

- Enable required interrupts: System interrupts that are required to get propagated to host are to be enabled individually by writing to [9-0] ENABLE_SET_INDEX bit field in the interrupt enable indexed set register (ICSS_INTC_ENABLE_SET_INDEX_REG). The interrupt to enable is the index value written. This sets the Enable Register bit of the given index.
- Enable required host interrupts: By writing 1h to the appropriate bit of the [9-0] HINT_ENABLE_SET_INDEX bit field in the host interrupt enable indexed set register (ICSS_INTC_HINT_ENABLE_SET_INDEX_REG), enable the required host interrupts. The host interrupt to enable is the index value written. This enables the host interrupt output or triggers the output again if that host interrupt is already enabled.
- Enable all host interrupts: By setting the [0] ENABLE_HINT_ANY bit in the global enable register (ICSS_INTC_GLOBAL_ENABLE_HINT_REG) to 1h, all host interrupts will be enabled. Individual host interrupts are still enabled or disabled from their individual enables and are not overridden by the global enable.

7.2.7.1.2.2 PRU-ICSS Interrupt Status Checking

The next stage is to capture which interrupts are pending. There are two kinds of pending status: raw status and enabled status. Raw status is the pending status of the interrupt without regards to the enable bit for the interrupt. Enabled status is the pending status of the interrupts with the enable bits active. When the enable bit is inactive, the enabled status will always be inactive. The enabled status of interrupts is captured in interrupt status enabled/clear registers (ICSS_INTC_ENA_STATUS_REG0 to ICSS_INTC_ENA_STATUS_REG4).

Status of interrupt 'N' is indicated by the N-th bit of ICSS_INTC_ENA_STATUS_REG0 to ICSS_INTC_ENA_STATUS_REG4. Since there are 160 interrupts, five 32-bit registers are used to capture the enabled status of interrupts. The pending status reflects whether the interrupt occurred since the last time the status register bit was cleared. Each bit in the status register can be individually cleared.

7.2.7.1.2.3 PRU-ICSS Interrupt Channel Mapping

The INTC has 10 internal channels to which enabled interrupts can be mapped. Channel 0 has highest priority and channel 9 has the lowest priority. Channels are used to group the interrupts into a smaller number of priorities that can be given to a host interface with a very small number of interrupt inputs.

When multiple interrupts are mapped to the same channel their interrupts are ORed together so that when either is active the output is active. The channel map registers (ICSS_INTC_CH_MAP_REGi) define the channel for each interrupt. There is one register per 4 interrupts; therefore, there are 16 channel map registers for a of 64 interrupts. The channel for each interrupt can be set using these registers.

7.2.7.1.2.3.1 PRU-ICSS Host Interrupt Mapping

The hosts can be the local PRU processors (PRU0 and PRU1) as well as device processors located outside PRU-ICSS such as ARM, etc. The 10 channels from the INTC can be mapped to any of the 10 Host interrupts. The Host map registers (ICSS_INTC_HINT_MAP_REG0 to ICSS_INTC_HINT_MAP_REG4) define the channel for each interrupt. There is one register per 4 channels; therefore, there are 3 host map registers for 10 channels. When multiple channels are mapped to the same host interrupt, then prioritization is done to select which interrupt is in the highest-priority channel and which should be sent first to the host.

7.2.7.1.2.3.2 PRU-ICSS Interrupt Prioritization

The next stage of the INTC is prioritization. Since multiple interrupts can feed into a single channel and multiple channels can feed into a single host interrupt, it is necessary to read the status of all interrupts to determine the highest priority interrupt that is pending. The INTC provides hardware to perform this prioritization with a given scheme so that software does not have to do this. There are two levels of prioritizations:

- The first level of prioritization is between the active channels for a host interrupt. Channel 0 has the highest priority and channel 9 has the lowest. So the first level of prioritization picks the lowest numbered active channel.
- The second level of prioritization is between the active interrupts for the prioritized channel. The interrupt in position 0 has the highest priority and interrupt 159 has the lowest priority. So the second level of prioritization picks the lowest position active interrupt.

This is the final prioritized interrupt for the host interrupt and is stored in the global prioritized innterrupt register (ICSS_INTC_GLB_PRI_INTR_REG). The highest priority pending interrupt with respect to each host interrupts can be obtained using the host interrupt prioritized interrupt registers (ICSS_INTC_PRI_HINT_REGj where j = 0 to 19).

7.2.7.1.2.4 PRU-ICSS Interrupt Nesting

The INTC can also perform a nesting function in its prioritization. Nesting is a method of disabling certain interrupts (usually lower-priority interrupts) when an interrupt is taken so that only those desired interrupts can trigger to the host while it is servicing the current interrupt. The typical usage is to nest on the current interrupt and disable all interrupts of the same or lower priority (or channel). Then the host will only be interrupted from a higher priority interrupt.

The nesting is done in one of three methods:

1. Nesting for all host interrupts, based on channel priority: When an interrupt is taken, the nesting level is set to its channel priority. From then, that channel priority and all lower priority channels will be disabled from generating host interrupts and only higher priority channels are allowed. When the interrupt is completely serviced, the nesting level is returned to its original value. When there is no interrupt being serviced, there are no channels disabled due to nesting. The global nesting level register (ICSS_INTC_GLB_NEST_LEVEL_REG) allows the checking and setting of the global nesting level across all host interrupts. The nesting level is the channel (and all of lower priority channels) that are nested out because of a current interrupt.
2. Nesting for individual host interrupts, based on channel priority: Always nest based on channel priority for each host interrupt individually. When an interrupt is taken on a host interrupt, then, the nesting level is set to its channel priority for just that host interrupt, and other host interrupts do not have their nesting affected. Then for that host interrupt, equal or lower priority channels will not interrupt the host but may on other host interrupts if programmed. When the interrupt is completely serviced the nesting level for the host interrupt is returned to its original value. The host interrupt nesting level registers (ICSS_INTC_NEST_LEVEL_REG_j where j = 0 to 19) display and control the nesting level for each host interrupt. The nesting level controls which channel and lower priority channels are nested. There is one register per host interrupt.
3. Software manually performs the nesting of interrupts. When an interrupt is taken, the software will disable all the host interrupts, manually update the enables for any or all the interrupts, and then re-enables all the host interrupts. This now allows only the interrupts that are still enabled to trigger to the host. When the interrupt is completely serviced the software must reverse the changes to re-enable the nested out interrupts. This method requires the most software interaction but gives the most flexibility if simple channel based nesting mechanisms are not adequate.

7.2.7.1.2.5 PRU-ICSS Interrupt Status Clearing

After servicing the interrupt (after execution of the ISR), interrupt status is to be cleared. If a interrupt status is not cleared, then another host interrupt may not be triggered or another host interrupt may be triggered incorrectly. It is also essential to clear all interrupts before the PRU is halted as the PRU does not power down unless all the interrupt status are cleared. For clearing the status of an interrupt, whose interrupt number is N, write a 1h to the Nth bit position in the interrupt status enabled/clear registers (ICSS_INTC_ENA_STATUS_REG0 to ICSS_INTC_ENA_STATUS_REG4). Interrupt N can also be cleared by writing the value N into the interrupt status indexed clear register (ICSS_INTC_STATUS_CLR_INDEX_REG).

7.2.7.1.3 PRU-ICSS Interrupt Disabling

At any time, if any interrupt is not to be propagated to the host, then that interrupt should be disabled. For disabling an interrupt whose interrupt number is N, write a 1h to the Nth bit in the interrupt enable clear registers (ICSS_INTC_ENABLE_CLR_REG0 to ICSS_INTC_ENABLE_CLR_REG4). Interrupt N can also be disabled by writing the value N in the interrupt enable clear index register (ICSS_INTC_ENABLE_CLR_INDEX_REG).

7.2.7.2 PRU-ICSS Interrupt Controller Basic Programming Model

Follow these steps to configure the interrupt controller.

1. Set polarity and type of event through the Interrupt Polarity Registers (ICSS_INTC_POLARITY_REG0 to ICSS_INTC_POLARITY_REG4) and the Interrupt Type Registers (ICSS_INTC_POLARITY_REG0 to ICSS_INTC_POLARITY_REG4). Polarity of all interrupts is always high. Type of all interrupts is always pulse (after the processing block).
2. Map event to INTC channel through ICSS_INTC_CH_MAP_REG_i (where i=0 to 39) channel mapping registers.
3. Map channel to host interrupt through ICSS_INTC_HINT_MAP_REG0 to ICSS_INTC_HINT_MAP_REG4 registers. Recommended channel “x” to be mapped to host interrupt “x”.
4. Clear interrupt by writing 1h to ICSS_INTC_ENA_STATUS_REG0 to ICSS_INTC_ENA_STATUS_REG4 registers.
5. Enable host interrupt by writing index value to ICSS_INTC_HINT_ENABLE_SET_INDEX_REG register.
6. Enable interrupt nesting if desired.
7. Globally enable all interrupts through register ICSS_INTC_GLOBAL_ENABLE_HINT_REG[0] ENABLE_HINT_ANY bit.

7.2.7.3 PRU-ICSS Interrupt Requests Mapping

The PRU_ICSSM Interrupt Controller lines 0 through 31 are mapped to internal events which are generated by PRU-ICSS integrated modules. Lines 32 to 63 are external and generated from different peripherals. [Table 7-64](#) shows mapping of the different PRU-ICSS internally sourced IRQ events to PRU-ICSS INTC interrupt lines 0 through 63.

Table 7-64. PRU-ICSS Internal Interrupts

Event Number	Source	
	MII_RT_REG.MII_RT_EVENT_EN =1 mode (default)	MII_RT_REG.MII_RT_EVENT_EN =0 mode
PRU-ICSS INTC		
63	pr0_slv_intr[63]_intr_pend(external)	
62	pr0_slv_intr[62]_intr_pend(external)	
61	pr0_slv_intr[61]_intr_pend(external)	
60	pr0_slv_intr[60]_intr_pend(external)	
59	pr0_slv_intr[59]_intr_pend(external)	
58	pr0_slv_intr[58]_intr_pend(external)	
57	pr0_slv_intr[57]_intr_pend(external)	
56	pr0_slv_intr[56]_intr_pend(external)	
55	pr0_mii1_col and pr0_mii1_txen (external)	pr0_slv_intr<55>_intr_pend(external)
54	PRU1_RX_EOF	pr0_slv_intr<54>_intr_pend(external)
53	MDIO_MII_LINK[1]	pr0_slv_intr<53>_intr_pend(external)
52	PORT1_TX_OVERFLOW	pr0_slv_intr<52>_intr_pend(external)
51	PORT1_TX_UNDERFLOW	pr0_slv_intr<51>_intr_pend(external)
50	PRU1_RX_OVERFLOW	pr0_slv_intr<50>_intr_pend(external)
49	PRU1_RX_NIBBLE_ODD	pr0_slv_intr<49>_intr_pend(external)
48	PRU1_RX_CRC	pr0_slv_intr<48>_intr_pend(external)
47	PRU1_RX_SOF	pr0_slv_intr<47>_intr_pend(external)
46	PRU1_RX_SFD	pr0_slv_intr<46>_intr_pend(external)
45	PRU1_RX_ERR32	pr0_slv_intr<45>_intr_pend(external)
44	PRU1_RX_ERR	pr0_slv_intr<44>_intr_pend(external)
43	pr0_mii0_col and pr0_mii0_txen (external)	pr0_slv_intr<43>_intr_pend(external)
42	PRU0_RX_EOF	pr0_slv_intr<42>_intr_pend(external)
41	MDIO_MII_LINK[0]	pr0_slv_intr<41>_intr_pend(external)
40	PORT0_TX_OVERFLOW	pr0_slv_intr<40>_intr_pend(external)
39	PORT0_TX_UNDERFLOW	pr0_slv_intr<39>_intr_pend(external)
38	PRU0_RX_OVERFLOW	pr0_slv_intr<38>_intr_pend(external)
37	PRU0_RX_NIBBLE_ODD	pr0_slv_intr<37>_intr_pend(external)
36	PRU0_RX_CRC	pr0_slv_intr<36>_intr_pend(external)
35	PRU0_RX_SOF	pr0_slv_intr<35>_intr_pend(external)
34	PRU0_RX_SFD	pr0_slv_intr<34>_intr_pend(external)
33	PRU0_RX_ERR32	pr0_slv_intr<33>_intr_pend(external)
32	PRU0_RX_ERR	pr0_slv_intr<32>_intr_pend(external)
31	pr0_pru_mst_intr[15]_intr_req	
30	pr0_pru_mst_intr[14]_intr_req	
29	pr0_pru_mst_intr[13]_intr_req	
28	pr0_pru_mst_intr[12]_intr_req	

Table 7-64. PRU-ICSS Internal Interrupts (continued)

Event Number	Source
	MII_RT_REG.MII_RT_EVENT_EN =1 mode (default) MII_RT_REG.MII_RT_EVENT_EN =0 mode
27	pr0_pru_mst_intr[11]_intr_req
26	pr0_pru_mst_intr[10]_intr_req
25	pr0_pru_mst_intr[9]_intr_req
24	pr0_pru_mst_intr[8]_intr_req
23	pr0_pru_mst_intr[7]_intr_req
22	pr0_pru_mst_intr[6]_intr_req
21	pr0_pru_mst_intr[5]_intr_req
20	pr0_pru_mst_intr[4]_intr_req
19	pr0_pru_mst_intr[3]_intr_req
18	pr0_pru_mst_intr[2]_intr_req
17	pr0_pru_mst_intr[1]_intr_req
16	pr0_pru_mst_intr[0]_intr_req
15	pr0_ecap_intr_req
14	pr0_sync0_out_pend
13	pr0_sync1_out_pend
12	pr0_latch0_in (input to PRU-ICSS)
11	pr0_latch1_in (input to PRU-ICSS)
10	pr0_pdi_wd_exp_pend
9	pr0_pd_wd_exp_pend
8	pr0_digio_event_req
7	pr0_iep_tim_cap_cmp_pend
6	pr0_uart0_uint_intr_req
5	pr0_uart0_utxevt_intr_req
4	pr0_uart0_urxevt_intr_req
3	reset_iso_req
2	pr0_pru1_r31_status_cnt16
1	pr0_pru0_r31_status_cnt16
0	pr0_ecc_err_intr

7.2.8 PRU-ICSS UART Module

This section describes an Universal Asynchronous Receive and Transmit (UART) module integrated into each of the PRU-ICSS subsystems, named respectively - PRU-ICSS0_UART0 and PRU-ICSS1_UART0. Hereinafter the module will be referred as PRU-ICSS UART0.

7.2.8.1 PRU-ICSS UART Overview

The PRU-ICSS UART0 peripheral is based on the industry standard TL16C550 asynchronous communications element, which in turn is a functional upgrade of the TL16C450. The information in this chapter assumes that user is familiar with these standards.

Functionally similar to the TL16C450 on power up (single character or TL16C450 mode), the PRU-ICSS UART0 can be placed in an alternate FIFO (TL16C550) mode. This relieves the CPU of excessive software overhead by buffering received and transmitted characters. The receiver and transmitter FIFOs store up to 16 bytes including three additional bits of error status per byte for the receiver FIFO.

The PRU-ICSS UART0 performs serial-to-parallel conversions on data received from a peripheral device and parallel-to-serial conversion on data received from the CPU. The CPU can read the PRU-ICSS UART0 status at any time. The PRU-ICSS UART0 includes control capability and a processor interrupt system that can be tailored to minimize software management of the communications link.

The PRU-ICSS UART0 includes a programmable baud generator capable of dividing the PRU-ICSS UART0 input clock by divisors from 1 to 65535 and producing a 16× reference clock or a 13× reference clock for the internal transmitter and receiver logic.

7.2.8.2 PRU-ICSS UART Environment

This section describes the PRU-ICSS UART0 module interface to the device environment.

7.2.8.2.1 PRU-ICSS UART Pin Multiplexing

Pin multiplexing is controlled using a combination of hardware configuration at device reset and software programmable register settings. For more information on the PRU-ICSS UART0 pin multiplexing, refer to the , *Pad Configuration Registers* in the chapter, *CTRL_MMR0*.

7.2.8.2.2 PRU-ICSS UART Signal Descriptions

The PRU-ICSS UART0 utilize a minimal number of signal connections to interface with external devices. The PRU-ICSS UART0 signal descriptions are described in [Table 7-65](#).

Table 7-65. PRUSS_UART0 Signal Descriptions

Signal Name	Signal Type	Function
UART0_TXD	Output	Serial data transmit
UART0_RXD	Input	Serial data receive
UART0_CTS	Input	Clear-to-Send handshaking signal
UART0_RTS	Output	Request-to-Send handshaking signal

7.2.8.2.3 PRU-ICSS UART Protocol Description and Data Format

7.2.8.2.3.1 PRU-ICSS UART Transmission Protocol

The PRU-ICSS UART0 transmitter section includes a transmitter hold register (THR), memory mapped in the register UART_RBR_TBR[17-8] TBR_DATA bitfield and a transmitter shift register (TSR), which is NOT memory mapped. When the PRU-ICSS UART0 is in the FIFO mode, THR is a 16-byte FIFO. Transmitter section control is a function of the PRU-ICSS UART0 line control register UART_LCTR. Based on the settings chosen in this register, the PRU-ICSS UART0 transmitter sends the following to the receiving device:

- 1 START bit
- 5, 6, 7, or 8 data bits
- 1 PARITY bit (optional)
- 1, 1.5, or 2 STOP bits

THR receives data from the internal data bus, and when TSR (transmitter shift register) is ready, the PRU-ICSS UART0 moves the data from THR to TSR. The PRU-ICSS UART0 serializes the data in TSR and transmits the data on the UART0_TXD pin.

In the non-FIFO mode, if THR is empty and the Transmitter Holding Register Empty interrupt (THRE) is enabled in the interrupt enable register (UART_INT_EN[1] ETBEI), an interrupt is generated. This interrupt is cleared when a character is loaded into THR or the interrupt identification register UART_INT_FIFO bitfield [3-1] IIR_INTID is read. In the FIFO mode, the interrupt is generated when the transmitter FIFO is empty, and it is cleared when at least one byte is loaded into the FIFO or UART_INT_FIFO[3-1] IIR_INTID bitfield is read.

7.2.8.2.3.2 PRU-ICSS UART Reception Protocol

The PRU-ICSS UART0 receiver section includes a receiver shift register (RSR), that is not memory mapped, and a receiver buffer register (RBR), memory mapped as the register **UART_RBR_TBR[7-0] RBR_DATA** bitfield. When the PRU-ICSS UART0 is in the FIFO mode, RBR is a 16-byte FIFO. Receiver section control is a function of the PRU-ICSS UART0 line control register - **UART_LCTR**. Based on the settings chosen in this register, the PRU-ICSS UART0 receiver accepts the following from the transmitting device:

- 1 START bit
- 5, 6, 7, or 8 data bits
- 1 PARITY bit (optional)
- 1 STOP bit (any other STOP bits transferred with the above data are not detected)

RSR receives the data bits from the UART0_RXD pin. Then RSR concatenates the data bits and moves the resulting value into RBR (or the receiver FIFO), accessible in the RBR_TBR[7-0] RBR_DATA register bitfield. The PRU-ICSS UART0 also stores three bits of error status information next to each received character, to record a parity error, framing error, or break.

In the non-FIFO mode, when a character is placed in RBR and the receiver data available interrupt is enabled in the interrupt enable register - **UART_INT_EN[0] ERBI**, an interrupt is generated. This interrupt is cleared when the character is read from RBR. In the FIFO mode, the interrupt is generated when the FIFO is filled to the trigger level selected in the FIFO control MSB part of the register **UART_INT_FIFO**, and it is cleared when the FIFO contents drop below the trigger level.

7.2.8.2.3.3 PRU-ICSS UART Data Format

The PRU-ICSS UART0 transmits in the following format:

1 START bit + data bits (5, 6, 7, 8) + 1 PARITY bit (optional) + STOP bit (1, 1.5, 2)

It transmits 1 START bit; 5, 6, 7, or 8 data bits, depending on the data width selection; 1 PARITY bit, if parity is selected; and 1, 1.5, or 2 STOP bits, depending on the STOP bit selection.

The PRU-ICSS UART0 receives in the following format:

1 START bit + data bits (5, 6, 7, 8) + 1 PARITY bit (optional) + 1 STOP bit

It receives 1 START bit; 5, 6, 7, or 8 data bits, depending on the data width selection; 1 PARITY bit, if parity is selected; and 1 STOP bit.

The protocol formats are shown in [Figure 7-45](#).

Figure 7-45. PRU-ICSS UART Protocol Formats

Transmit/Receive for 5-bit data, parity Enable, 1 STOP bit



Transmit/Receive for 6-bit data, parity Enable, 1 STOP bit





Transmit/Receive for 7-bit data, parity Enable, 1 STOP bit



Transmit/Receive for 8-bit data, parity Enable, 1 STOP bit

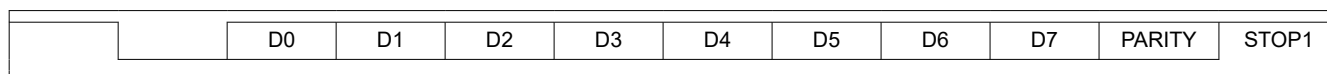

7.2.8.2.3.3.1 Frame Formatting

Character length is specified using the UART_LCTR[0] WLS0 and UART_LCTR[1] WLS1 bits (see [Table 7-67](#)).

The number of stop-bits is specified using the UART_LCTR[2] STB bit (see [Table 7-67](#)).

The parity bit is programmed using the UART_LCTR[5] SP, UART_LCTR[4] EPS, and UART_LCTR[3] PEN bits (see [Table 7-66](#)).

Table 7-66. Relationship Between SP, EPS, and PEN Bits in LCTR

SP Bit	EPS Bit	PEN Bit	Parity Option
x	x	0	Parity disabled: No PARITY bit is transmitted or checked.
0	0	1	Odd parity selected: Odd number of logic 1s.
0	1	1	Even parity selected: Even number of logic 1s.
1	0	1	Stick parity selected with PARITY bit transmitted and checked as set.
1	1	1	Stick parity selected with PARITY bit transmitted and checked as cleared.

Table 7-67. Number of STOP Bits Generated

STB Bit	WLS Bit	Word Length Selected with WLS Bits	Number of STOP Bits Generated	Baud Clock (BCLK) Cycles
0	x	Any word length	1	16
1	0h	5 bits	1.5	24
1	1h	6 bits	2	32
1	2h	7 bits	2	32
1	3h	8 bits	2	32

7.2.8.2.4 PRU-ICSS UART Clock Generation and Control

The PRU-ICSS UART0 bit clock is derived from an input clock to the PRU-ICSS UART0. See the device-specific Datasheet to check the maximum data rate supported by the PRU-ICSS UART0.

[Figure 7-46](#) is a conceptual clock generation diagram for the PRU-ICSS UART0. The processor clock generator receives a signal from an external clock source and produces a PRU-ICSS UART0 input clock with a programmed frequency. The PRU-ICSS UART0 contains a programmable baud generator that takes an input clock and divides it by a divisor in the range between 1 and $(2^{16} - 1)$ to produce a baud clock (BCLK).

The frequency of BCLK is sixteen times ($16\times$) the baud rate (each received or transmitted bit lasts 16 BCLK cycles) or thirteen times ($13\times$) the baud rate (each received or transmitted bit lasts 13 BCLK cycles). When the PRU-ICSS UART0 is receiving, the bit is sampled in the 8th BCLK cycle for $16\times$ over sampling mode and on the 6th BCLK cycle for $13\times$ over-sampling mode. The $16\times$ or $13\times$ reference clock is selected by configuring the mode definition register: UART_MODE[0] OSM_SEL bit. The formula to calculate the divisor is:

$$\text{Divisor} = \frac{\text{UART input clock frequency}}{\text{Desired baud rate} \times 16} \quad [\text{MODE.OSM_SEL} = 0\text{h}]$$

icss-13

$$\text{Divisor} = \frac{\text{UART input clock frequency}}{\text{Desired baud rate} \times 13} \quad [\text{MODE.OSM_SEL} = 1\text{h}]$$

icss-14

Two 8-bit register fields:

- UART_DIVMSB[7-0] DLH
- UART_DIVLSB[7-0] DLL,

called divisor latches, hold this 16-bit divisor. DLH holds the most significant bits of the divisor, and DLL holds the least significant bits of the divisor. For information about these register fields, see the PRU-ICSS UART0 register descriptions in the *PRU_UART_UART0 Registers*. These divisor latches must be loaded during initialization of the PRU-ICSS UART0 in order to ensure desired operation of the baud generator. Writing to the divisor latches results in two wait states being inserted during the write access while the baud generator is loaded with the new value.

Figure 7-47 summarizes the relationship between the transferred data bit, BCLK, and the PRU-ICSS UART0 input clock. Note that the timing relationship depicted in Figure 7-47 shows that each bit lasts for 16 BCLK cycles. This is in case of 16x over-sampling mode. For 13x over-sampling mode each bit lasts for 13 BCLK cycles.

Example baud rates and divisor values relative to a 150 MHz PRU-ICSS UART0 input clock and 16x over-sampling mode are shown in Table 7-68.

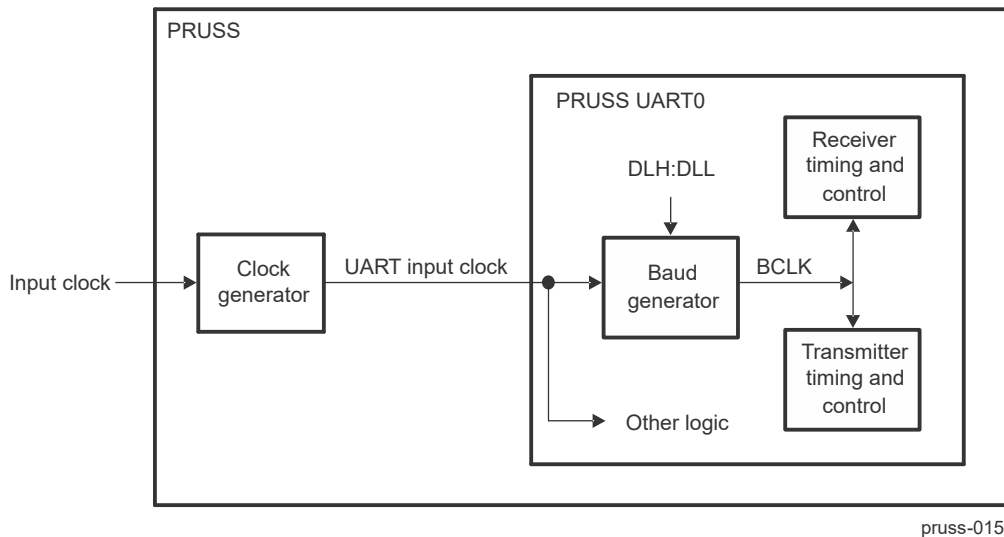
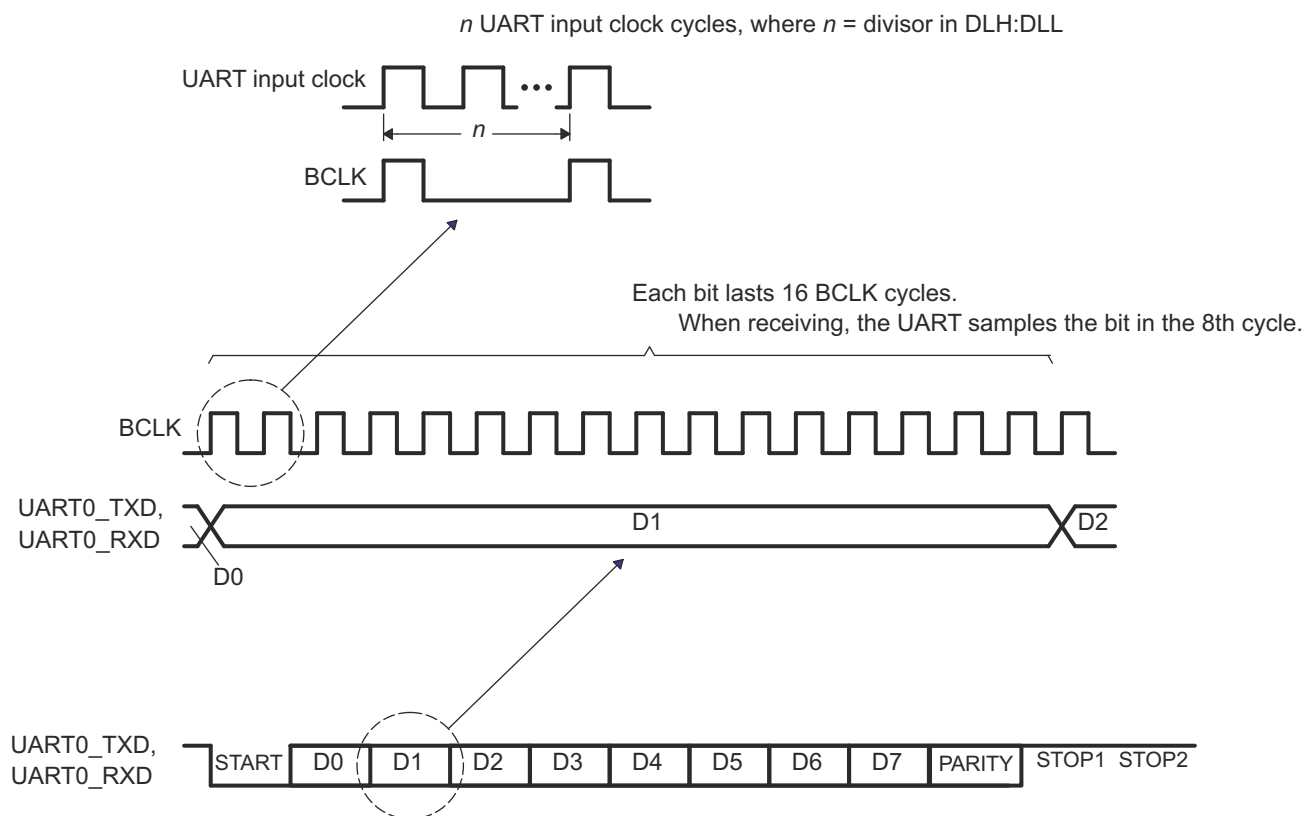

Figure 7-46. PRU-ICSS UART Clock Generation Diagram

Figure 7-47. Relationships Between PRU-ICSS UART Data Bit, BCLK, and Input Clock
Table 7-68. Baud Rate Examples for 192-MHZ PRU-ICSS UART Input Clock and 16× Over-sampling Mode

Baud Rate	Divisor Value	Actual Baud Rate	Error (%)
2400	5000	2400	0.00
4800	2500	4800	0.00
9600	1250	9600	0.00
19200	625	19200	0.00
38400	313	38338.658	-0.16
56000	214	56074.766	0.13
115200	104	115384.6	0.16
128000	94	127659.574	-0.27
3000000	4	3000000	0.00
6000000	2	3000000	0.00
12000000	1	12000000	12000000

Table 7-69. Baud Rate Examples for 192-MHZ PRU-ICSS UART Input Clock and 13× Over-sampling Mode

Baud Rate	Divisor Value	Actual Baud Rate	Error (%)
2400	6154	2399.940	-0.0025
4800	3077	4799.880	-0.0025
9600	1538	9602.881	0.03
19200	769	19205.762	0.03
38400	385	38361.638	-0.10
56000	264	55944.056	-0.10
115200	128	115384.6	0.16

Table 7-69. Baud Rate Examples for 192-MHZ PRU-ICSS UART Input Clock and 13× Over-sampling Mode (continued)

Baud Rate	Divisor Value	Actual Baud Rate	Error (%)
128000	115	128428.094	0.33

7.2.8.3 PRU-ICSS UART Functional Description

7.2.8.3.1 PRU-ICSS UART Functional Block Diagram

A functional block diagram of the PRU-ICSS UART0 is shown in [Figure 7-48](#).

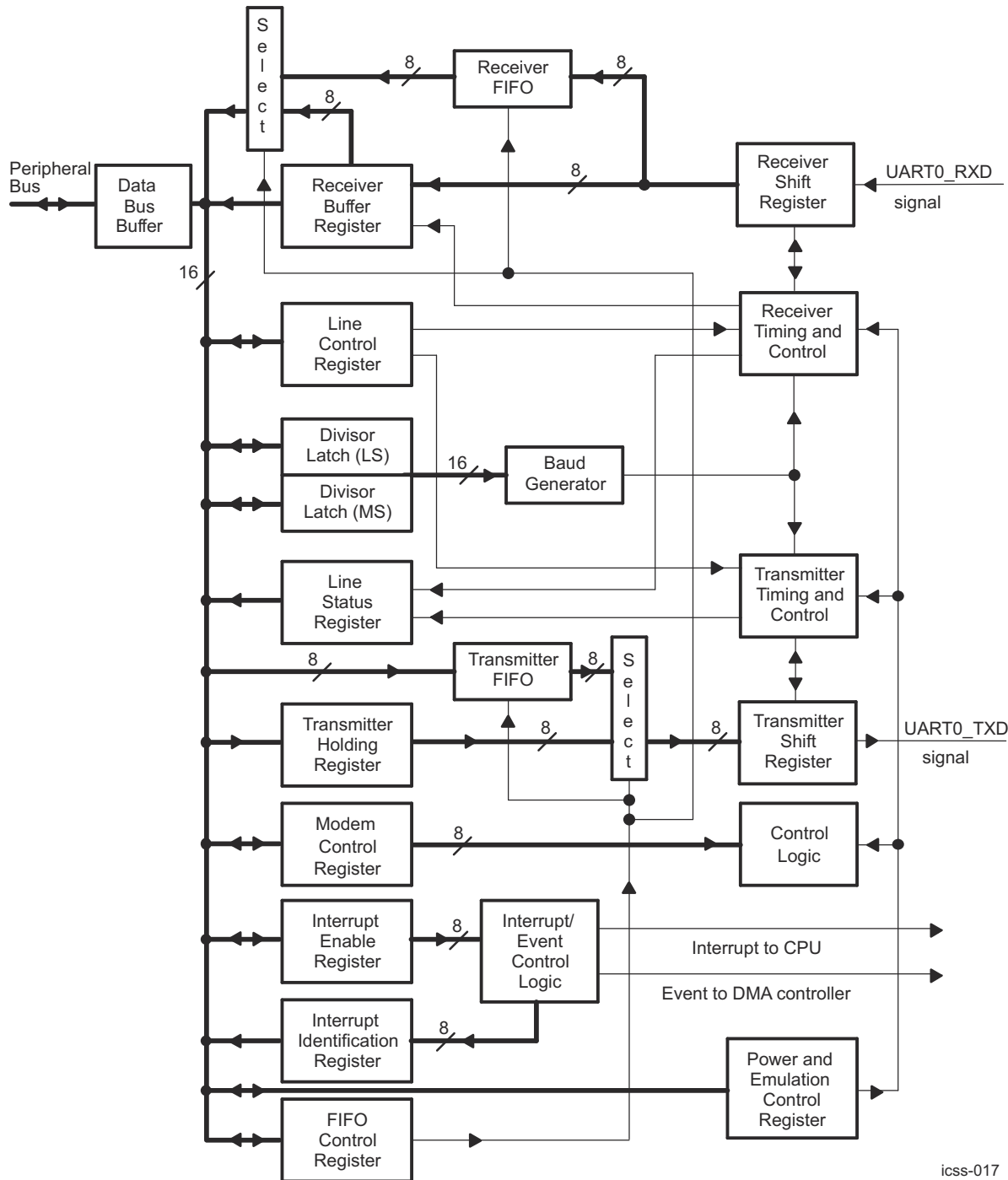

icss-017

NOTE: The value *n* indicates the applicable UART where there are multiple instances. For the PRU-ICSS, there is only one instance and all UART signals should reflect this (e.g., UART0_TXD instead of UARTn_TXD).

Figure 7-48. PRU-ICSS UART Block Diagram

7.2.8.3.2 PRU-ICSS UART Reset Considerations

7.2.8.3.2.1 PRU-ICSS UART Software Reset Considerations

Two bits in the power and emulation management register - UART_PWR, control resetting the parts of the PRU-ICSS UART0:

- The bit [14]UTRST controls resetting the transmitter only. If bit [14]UTRST = 1h, the transmitter is enabled and active;
if bit [14]UTRST = 0h, the transmitter is disabled and in reset state.
- The bit [13]URRST controls resetting the receiver only. If [13]URRST = 1h, the receiver is enabled and active;
if bit [13]URRST = 0h, the receiver is disabled and in reset state.

In each case, putting the receiver and/or transmitter in reset will reset the state machine of the affected portion but will not affect the PRU-ICSS UART0 registers.

7.2.8.3.2.2 PRU-ICSS UART Hardware Reset Considerations

When the processor RESET pin is asserted, the entire processor is reset and is held in the reset state until the RESET pin is released. As part of a device reset, the PRU-ICSS UART0 state machine is reset and the PRU-ICSS UART0 registers are forced to their default states. The default states of the registers are shown in .

7.2.8.3.3 PRU-ICSS UART Power Management

The PRU-ICSS UART0 peripheral can be placed in reduced-power modes to conserve power during periods of low activity. The power management of the PRU-ICSS UART0 peripheral and other PRU-ICSS peripherals is controlled by the device Power Sleep Controller (PSC). The PSC acts as a power management controller for all of the peripherals on the device. For more details on the power management procedures using the PSC, refer to the , *Power Management* section.

7.2.8.3.4 PRU-ICSS UART Interrupt Support

7.2.8.3.4.1 PRU-ICSS UART Interrupt Events and Requests

The PRU-ICSS UART0 generates the interrupt requests described in [Table 7-70](#). All requests are multiplexed through an arbiter to a single PRU-ICSS UART0 interrupt request to the CPU, as shown in [Figure 7-49](#). Each of the interrupt requests has an enable bit in the interrupt enable register (IER) - UART_INT_EN and is recorded in [3-1]IIR_INTID bitfield of UART_INT_FIFO register.

If an interrupt occurs and the corresponding enable bit is set to 1h, the interrupt request is recorded in corresponding UART_INT_FIFO[3-1] IIR_INTID bitfield and is forwarded to the CPU. If an interrupt occurs and the corresponding enable bit is cleared to 0h, the interrupt request is blocked. The interrupt request is neither recorded in UART_INT_FIFO[3-1] IIR_INTID, nor forwarded to the CPU.

7.2.8.3.4.2 PRU-ICSS UART Interrupt Multiplexing

The PRU-ICSS UART0 have dedicated interrupt signals to the CPU and the interrupts are not multiplexed with any other interrupt source.

Table 7-70. PRU-ICSS UART Interrupt Requests Descriptions

PRU-ICSS UART0 Interrupt Request	Interrupt Source	Comment
THREINT	THR-empty condition: The transmitter holding register (THR) or the transmitter FIFO is empty. All of the data has been copied from THR, (i.e. UART_RBR_TBR[7-0] RBR_DATA) to the transmitter shift register (TSR).	If THREINT is enabled in UART_INT_EN register by setting the [1]ETBEI bit, it is recorded in [3-1]IIR_INTID bitfield. As an alternative to using THREINT, the CPU can poll the THRE bit in the line status register UART_LSR1.
RDAINT	Receive data available in non-FIFO mode or trigger level reached in the FIFO mode.	If RDAINT is enabled in UART_INT_EN register, by setting the [0]ERBI bit, it is recorded in INTID bitfield. As an alternative to using RDAINT, the CPU can poll the [0]DR bit in the line status register UART_LSR1. In the FIFO mode, this is not a functionally equivalent alternative because the [0]DR bit does not respond to the FIFO trigger level. The [0]DR bit only indicates the presence or absence of unread characters.

Table 7-70. PRU-ICSS UART Interrupt Requests Descriptions (continued)

PRU-ICSS UART0 Interrupt Request	Interrupt Source	Comment
RTOINT	Receiver time-out condition (in the FIFO mode only): No characters have been removed from or input to the receiver FIFO during the last four character times (see Table 7-72), and there is at least one character in the receiver FIFO during this time.	The receiver time-out interrupt prevents the PRU-ICSS UART0 from waiting indefinitely, in the case when the receiver FIFO level is below the trigger level and thus does not generate a receiver data-ready interrupt. If RTOINT is enabled in UART_INT_EN register, by setting the [0]ERBI bit, it is recorded in UART_INT_FIFO[3-1] IIR_INTID bitfield. There is no status bit to reflect the occurrence of a time-out condition.
RLSINT	Receiver line status condition: An overrun error, parity error, framing error, or break has occurred.	If RLSINT is enabled in INT_EN register, by setting the [2]ELSI bit, it is recorded in UART_INT_FIFO[3-1] IIR_INTID bitfield. As an alternative to using RLSINT, the CPU can poll the following bits in the line status register UART_LSR1: overrun error indicator (bit [1]OE), parity error indicator (bit [2]PE), framing error indicator ([3]FE), and break indicator ([4]BI).

ADVANCE INFORMATION

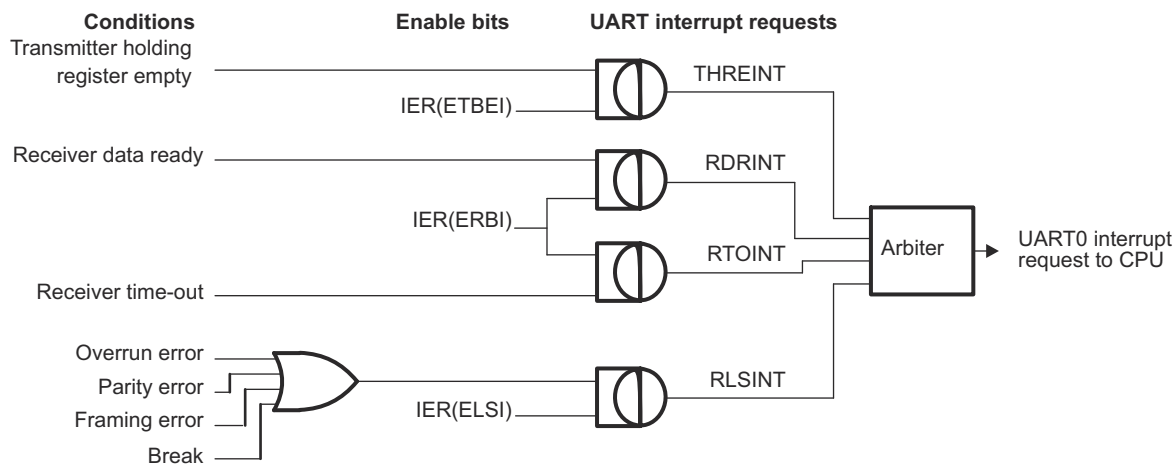

icss-018

Figure 7-49. PRU-ICSS UART Interrupt Request Enable Paths

Table 7-71. Interrupt Identification and Interrupt Clearing Information

Priority Level	IIR Bits				Interrupt Type	Interrupt Source	Event That Clears Interrupt
	3	2	1	0			
None	0	0	0	1	None	None	None
1	0	1	1	0	Receiver line status	Overrun error, parity error, framing error, or break is detected.	For an overrun error, reading the line status register UART_LSR1, clears the interrupt. For a parity error, framing error, or break, the interrupt is cleared only after all the erroneous data have been read.
2	0	1	0	0	Receiver data-ready	Non-FIFO mode: Receiver data is ready.	Non-FIFO mode: The receiver buffer register (RBR) is read.
						FIFO mode: Trigger level reached. If four character times pass with no access of the FIFO, the interrupt is asserted again.	FIFO mode: The FIFO drops below the trigger level.
2	1	1	0	0	Receiver time-out	FIFO mode only: No characters have been removed from or input to the receiver FIFO during the last four character times and there is at least one character in the receiver FIFO during this time.	One of the following events: <ul style="list-style-type: none"> • A character is read from the receiver FIFO • A new character arrives in the receiver FIFO • The [13]URRST bit in the power and emulation management register (UART_PWR) is loaded with 0h.
3	0	0	1	0	Transmitter holding register empty	Non-FIFO mode: Transmitter holding register (THR) is empty.	A character is written to the transmitter holding register (UART_RBR_TBR) or the interrupt identification register (UART_INT_FIFO) is read.
						FIFO mode: Transmitter FIFO is empty.	

7.2.8.3.5 PRU-ICSS UART DMA Event Support

In the FIFO mode, the PRU-ICSS UART0 generates the following two DMA events:

- **Receive event (URXEVT):** The trigger level for the receiver FIFO (1, 4, 8, or 14 characters) is set with the FIFO control UART_INT_FIFO[7-6] IIR_FIFOEN bitfield. Every time the trigger level is reached or a receiver time-out occurs, the PRU-ICSS UART0 sends a receive event to the UDMA controller. In response, the UDMA controller reads the data from the receiver FIFO by way of the receiver buffer register UART_RBR_TBR[7-0] RBR_DATA. Note that the receive event is not asserted if the data at the top of the receiver FIFO is erroneous even if the trigger level has been reached.
- **Transmit event (UTXEVT):** When the transmitter FIFO is empty (when the last byte in the transmitter FIFO has been copied to the transmitter shift register), the PRU-ICSS UART0 sends an UTXEVT signal to the UDMA controller. In response, the UDMA controller refills the transmitter FIFO by way of the transmitter holding register (THR) - UART_RBR_TBR[7-0] RBR_DATA. The UTXEVT signal is also sent to the UDMA controller when the PRU-ICSS UART0 is taken out of reset using the [14]UTRST bit in the power and emulation management register (UART_PWR).

Activity in DMA channels can be synchronized to these events. In the non-FIFO mode, the PRU-ICSS UART0 generates no DMA events. Any DMA channel synchronized to either of these events must be enabled at the time the PRU-ICSS UART0 event is generated. Otherwise, the DMA channel will miss the event and, unless the PRU-ICSS UART0 generates a new event, no data transfer will occur.

7.2.8.3.6 PRU-ICSS UART Operations

7.2.8.3.6.1 PRU-ICSS UART FIFO Modes

The following two modes can be used for servicing the receiver and transmitter FIFOs:

- FIFO interrupt mode. The FIFO is enabled and the associated interrupts are enabled. Interrupts are sent to the CPU to indicate when specific events occur.
- FIFO poll mode. The FIFO is enabled but the associated interrupts are disabled. The CPU polls status bits to detect specific events.

Because the receiver FIFO and the transmitter FIFO are controlled separately, either one or both can be placed into the interrupt mode or the poll mode.

7.2.8.3.6.1.1 PRU-ICSS UART FIFO Interrupt Mode

When the receiver FIFO is enabled in the FIFO control register (FCR), mapped in the MSB part of the register UART_INT_FIFO, and the receiver interrupts are enabled in the interrupt enable register UART_INT_EN, the interrupt mode is selected for the receiver FIFO. The following are important points about the receiver interrupts:

- The receiver data-ready interrupt is issued to the CPU when the FIFO has reached the trigger level that is programmed in FCR. It is cleared when the CPU or the DMA controller reads enough characters from the FIFO such that the FIFO drops below its programmed trigger level.
- The receiver line status interrupt is generated in response to an overrun error, a parity error, a framing error, or a break. This interrupt has higher priority than the receiver data-ready interrupt. For details, see [Section 7.2.8.3.4](#).
- The data-ready ([0]DR) bit in the line status register - UART_LSR1, indicates the presence or absence of characters in the receiver FIFO. The [0]DR bit is set when a character is transferred from the receiver shift register (RSR) to the empty receiver FIFO. The [0]DR bit remains set until the FIFO is empty again.
- A receiver time-out interrupt occurs if all of the following conditions exist:
 - At least one character is in the FIFO,
 - The most recent character was received more than four continuous character times ago. A character time is the time allotted for 1 START bit, n data bits, 1 PARITY bit, and 1 STOP bit, where n depends on the word length selected with the WLS0 and WLS1 bits of the line control register UART_LCTR. See [Table 7-72](#).
 - The most recent read of the FIFO has occurred more than four continuous character times before.
- Character times are calculated by using the baud rate.
- When a receiver time-out interrupt has occurred, it is cleared and the time-out timer is cleared when the CPU or the EDMA controller reads one character from the receiver FIFO. The interrupt is also cleared if a new character is received in the FIFO or if the URRST bit is cleared in the power and emulation management register - PWM.
- If a receiver time-out interrupt has not occurred, the time-out timer is cleared after a new character is received or after the CPU or EDMA reads the receiver FIFO.

When the transmitter FIFO is enabled in UART_INT_FIFO[0] IIR_IPEND bit and the transmitter holding register empty (THRE) interrupt is enabled in UART_INT_EN[1] ETBEI bit, the interrupt mode is selected for the transmitter FIFO. The THRE interrupt occurs when the transmitter FIFO is empty. It is cleared when the transmitter hold register (THR) UART_RBR_TBR[7-0] RBR_DATA bitfield is loaded (1 to 16 characters may be written to the transmitter FIFO while servicing this interrupt) or the [3-1]IIR_INTID bitfield is read in the interrupt identification register UART_INT_FIFO.

Table 7-72. Character Time for Word Lengths

Word Length (n)	Character Time	Four Character Times
5	Time for 8 bits	Time for 32 bits
6	Time for 9 bits	Time for 36 bits
7	Time for 10 bits	Time for 40 bits
8	Time for 11 bits	Time for 44 bits

7.2.8.3.6.1.2 PRU-ICSS UART FIFO Poll Mode

When the receiver FIFO is enabled in the FIFO control register (via setting the UART_INT_FIFO[0] IIR_IPEND to 1h) and the receiver interrupts are disabled in the interrupt enable register (UART_INT_EN), the poll mode is selected for the receiver FIFO. Similarly, when the transmitter FIFO is enabled via setting the same bit (UART_INT_FIFO[0] IIR_IPEND to 1h) and the transmitter interrupts are disabled, the transmitted FIFO is in the poll mode. In the poll mode, the CPU detects events by checking bits in the line status register - UART_LSR1:

- The UART_LSR1[7] RXFIFOE bit indicates whether there are any errors in the receiver FIFO.
- The UART_LSR1[6] TEMPTY bit indicates that both the transmitter holding register (THR) and the transmitter shift register (TSR) are empty.
- The UART_LSR1[5] THRE bit indicates when THR (mapped in the UART_RBR_TBR[7-0] RBR_DATA bitfield) is empty.

- The following line status register - UART_LSR1 bits specify which error or errors have occurred:
 - UART_LSR1[4] BI - Break Interrupt
 - UART_LSR1[3] FE – Framing Error
 - UART_LSR1[2] PE – Parity Error
 - UART_LSR1[1] OE – Overrun Error
- The UART_LSR1[0] DR (data-ready) bit is set as long as there is at least one byte in the receiver FIFO.

Also, in the FIFO poll mode:

- The interrupt identification ([3-1] IIR_INTID) bit field in register UART_INT_FIFO are not affected by any events because the interrupts are disabled.
- The PRU-ICSS UART0 does not indicate when the receiver FIFO trigger level is reached or when a receiver time-out occurs.

7.2.8.3.6.2 PRU-ICSS UART Autoflow Control

The PRU-ICSS UART0 can employ autoflow control by connecting the $\overline{\text{UART0_CTS}}$ and $\overline{\text{UART0_RTS}}$ signals. The $\overline{\text{UART0_CTS}}$ input must be active before the transmitter FIFO can transmit data. The $\overline{\text{UART0_RTS}}$ becomes active when the receiver needs more data and notifies the sending device. When $\overline{\text{UART0_RTS}}$ is connected to $\overline{\text{UART0_CTS}}$, data transmission does not occur unless the receiver FIFO has space for the data. Therefore, when two UARTs are connected as shown in Figure 7-50 with autoflow enabled (UART_MCTR[5] AFE = 1h), overrun errors are eliminated.

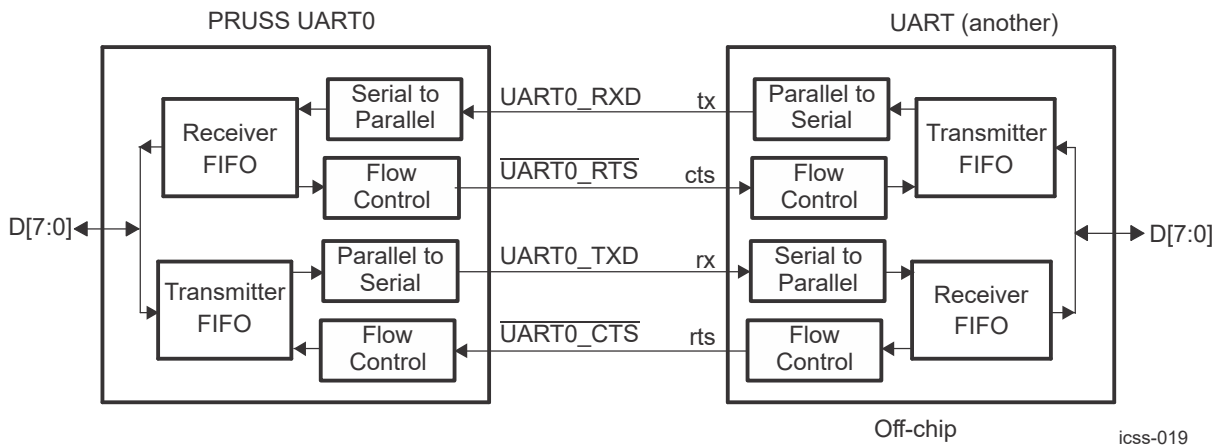
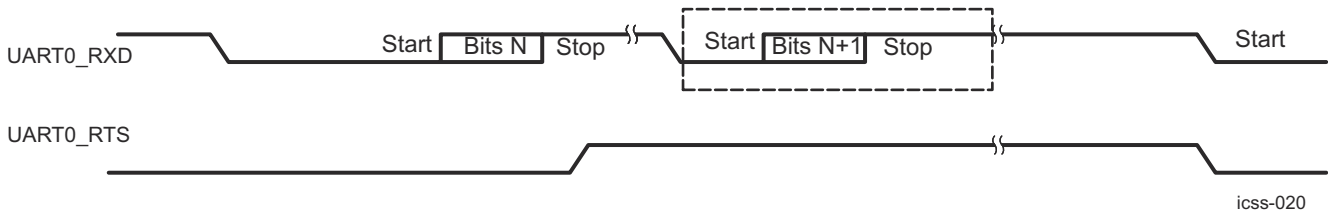

Figure 7-50. UART Interface Using Autoflow Diagram

7.2.8.3.6.2.1 PRU-ICSS UART Signal $\overline{\text{UART0_RTS}}$ Behavior

$\overline{\text{UART0_RTS}}$ data flow control originates in the receiver block (see Figure 7-48). When the receiver FIFO level reaches a trigger level of 1, 4, 8, or 14 (see Figure 7-51), $\overline{\text{UART0_RTS}}$ is deasserted. The sending UART may send an additional byte after the trigger level is reached (assuming the sending UART has another byte to send), because it may not recognize the deassertion of $\overline{\text{UART0_RTS}}$ until after it has begun sending the additional byte. For trigger level 1, 4, and 8, $\overline{\text{UART0_RTS}}$ is automatically reasserted once the receiver FIFO is emptied. For trigger level 14, $\overline{\text{UART0_RTS}}$ is automatically reasserted once the receiver FIFO drops below the trigger level.



A. N = Receiver FIFO trigger level.

icss-020

- B. The two blocks in dashed lines cover the case where an additional byte is sent.

Figure 7-51. Autoflow Functional Timing Waveforms for $\overline{\text{UART0_RTS}}$

7.2.8.3.6.2.2 PRU-ICSS UART Signal $\overline{\text{UART0_CTS}}$ Behavior

The transmitter checks $\overline{\text{UART0_CTS}}$ before sending the next data byte. If $\overline{\text{UART0_CTS}}$ is active, the transmitter sends the next byte. To stop the transmitter from sending the following byte, $\overline{\text{UART0_CTS}}$ must be released before the middle of the last STOP bit that is currently being sent (see Figure 7-52). When flow control is enabled, $\overline{\text{UART0_CTS}}$ level changes do not trigger interrupts because the device automatically controls its own transmitter. Without autoflow control, the transmitter sends any data present in the transmitter FIFO and a receiver overrun error may result.

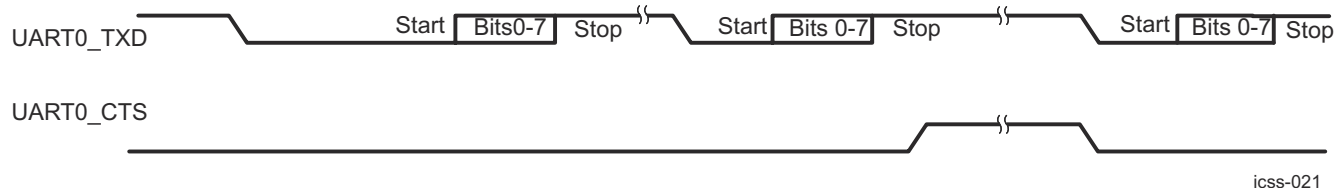

- A. When $\overline{\text{UART0_CTS}}$ is active (low), the transmitter keeps sending serial data out.
 B. When $\overline{\text{UART0_CTS}}$ goes high before the middle of the last STOP bit of the current byte, the transmitter finishes sending the current byte but it does not send the next byte.
 C. When $\overline{\text{UART0_CTS}}$ goes from high to low, the transmitter begins sending data again.

Figure 7-52. Autoflow Functional Timing Waveforms for $\overline{\text{UART0_CTS}}$

7.2.8.3.6.3 PRU-ICSS UART Loopback Control

The PRU-ICSS UART0 can be placed in the diagnostic mode using the [4]LOOP bit in the modem control register - UART_MCTR, which internally connects the PRU-ICSS UART0 output back to the PRU-ICSS UART0's input. In this mode, the transmit and receive data paths, the transmitter and receiver interrupts, and the modem control interrupts can be verified without connecting to another UART.

7.2.8.3.7 PRU-ICSS UART Emulation Considerations

The [0]FREE bit in the power and emulation management register (UART_PWR) determines how the PRU-ICSS UART0 responds to an emulation suspend event such as an emulator halt or breakpoint. If bit UART_PWR[0] FREE = 0h and a transmission is in progress, the PRU-ICSS UART0 halts after completing the one-word transmission; if bit UART_PWR[0] FREE = 0h and a transmission is not in progress, the PRU-ICSS UART0 halts immediately. If UART_PWR[0] FREE = 1h, the PRU-ICSS UART0 does not halt and continues operating normally.

Note also that most emulator accesses are transparent to PRU-ICSS UART0 operation. Emulator read operations do not affect any register contents, status bits, or operating states, with the exception of the interrupt identification register (UART_INT_FIFO). Emulator writes, however, may affect register contents and may affect PRU-ICSS UART0 operation, depending on what register is accessed and what value is written.

The PRU-ICSS UART0 registers can be read from or written to during emulation suspend events, even if the PRU-ICSS activity has stopped.

7.2.8.3.8 PRU-ICSS UART Exception Processing

7.2.8.3.8.1 PRU-ICSS UART Divisor Latch Not Programmed

Since the processor reset signal has no effect on the divisor latch, the divisor latch will have an unknown value after power up. If the divisor latch is not programmed after power up, the baud clock (BCLK) will not operate and will instead be set to a constant logic 1 state.

The divisor latch values should always be reinitialized following a processor reset.

7.2.8.3.8.2 Changing Operating Mode During Busy Serial Communication of PRU-ICSS UART

Since the serial link characteristics are based on how the control registers are programmed, the PRU-ICSS UART0 module will expect the control registers to be static while it is busy engaging in a serial communication. Therefore, changing the control registers while the module is still busy communicating with another serial device will most likely cause an error condition and should be avoided.

7.2.9 PRU-ICSS ECAP Module

7.2.9.1 PRU-ICSS eCAP Overview

7.2.9.1.1 Purpose of the PRU-ICSS eCAP Peripheral

The device PRU-ICSS integrated **enhanced capture (eCAP)** module targets:

- Sample rate measurements of audio inputs
- Speed measurements of rotating machinery (for example, toothed sprockets sensed via Hall sensors)
- Elapsed time measurements between position sensor pulses
- Period and duty cycle measurements of pulse train signals
- Decoding current or voltage amplitude derived from duty cycle encoded current/voltage sensors

7.2.9.1.2 PRU-ICSS eCAP Features

The device PRU-ICSS integrated eCAP module (signified as PRUSS1_eCAP_0 throughout the *PRU-ICSS eCAP Module* section) includes the following features:

- 32-bit time base counter
- 4-event time-stamp registers (each 32 bits)
- Edge polarity selection for up to four sequenced time-stamp capture events
- Interrupt on either of the four events
- Single shot capture of up to four event time-stamps
- Continuous mode capture of time-stamps in a four-deep circular buffer
- Absolute time-stamp capture
- Difference (Delta) mode time-stamp capture
- All above resources dedicated to a single input pin
- When not used in capture mode, the ECAP module can be configured as a single channel PWM output

7.2.9.2 PRU-ICSS ECAP Functional Description

For full description of the PRU-ICSS ECAP0 module and functionality, refer to the , *Enhanced Capture (eCAP) Module*.

7.2.9.2.1 PRU-ICSS Capture and APWM Operating Mode

The PRUSS1_eCAP_0 module resources can be used to implement a single-channel PWM generator (with 32 bit capabilities) when it is not being used for input captures. The counter operates in count-up mode, providing a time-base for asymmetrical pulse width modulation (PWM) waveforms. The PRUSS_ECAP_CAP1 and PRUSS_ECAP_CAP2 registers become the active period and compare registers, respectively, while PRUSS_ECAP_CAP3 and PRUSS_ECAP_CAP4 registers become the period and capture shadow registers, respectively. [Figure 7-53](#) is a high-level view of both the capture and auxiliary pulse-width modulator (APWM) modes of operation.

- A single pin is shared between CAP and APWM functions. In capture mode, it is an input; in APWM mode, it is an output.
- In APWM mode, writing any value to PRUSS_ECAP_CAP1/PRUSS_ECAP_CAP2 active registers also writes the same value to the corresponding shadow registers PRUSS_ECAP_CAP3/PRUSS_ECAP_CAP4. This emulates immediate mode. Writing to the shadow registers PRUSS_ECAP_CAP3/PRUSS_ECAP_CAP4 invokes the shadow mode.

Figure 7-53. PRU-ICSS Capture and APWM Modes of Operation

7.2.10 PRU-ICSS MII_RT Module

7.2.10.1 PRU-ICSS MII_RT Introduction

The Real-time Media Independent Interface (MII_RT) provides a programmable I/O interface for the PRUs to access and control up to two MII ports. The MII_RT module can also be configured to push and pull data independent of the PRU cores.

Note

In order to guarantee the MII_RT I/O timing values published in the device data sheet, the TX_CLK_DELAY_n (where n = 0 or 1) bit field in the MII_RT_TXCFG0/1 register must be set to 0h (default value).

7.2.10.1.1 PRU-ICSS MII_RT Features

The PRU-ICSS MII_RT module supports:

- Two MII ports
 - Each MII port has:
 - 32-Bytes RX L1 FIFO
 - 64-Bytes RX L2 FIFO (two memory banks: Bank0 = 32-Bytes and Bank1 = 32-Bytes)
 - 40-Bytes TX L1 FIFO one per port
 - 64-Bytes TX L2 FIFO one per port
 - Rate decoupling on TX L1 FIFO
 - Configurable pre-amble removal on RX L1 FIFO and insertion on TX L1 FIFO
 - Sync frame delimiter detection
 - Configurable TX L1 FIFO trigger (10 bits with 40 ns ticks)
- MII port multiplexer per direction to support line/ring structure
 - Link detection through RX_ERR
- Cyclic redundancy check (CRC)
 - CRC32 generation on TX path
 - CRC32 checker on RX path

7.2.10.1.2 Unsupported Features

The PRU-ICSS MII_RT module does not support:

- Auto padding in TX L1 FIFO
- Dynamic TX multiplexer switching during packet handling:
 - Can allow one PRU to handle both MII interfaces and a second PRU to manage the host and switch functions.

7.2.10.1.3 PRU-ICSS MII_RT Block Diagram

Figure 7-54 shows the MII_RT in context of the PRU-ICSS.

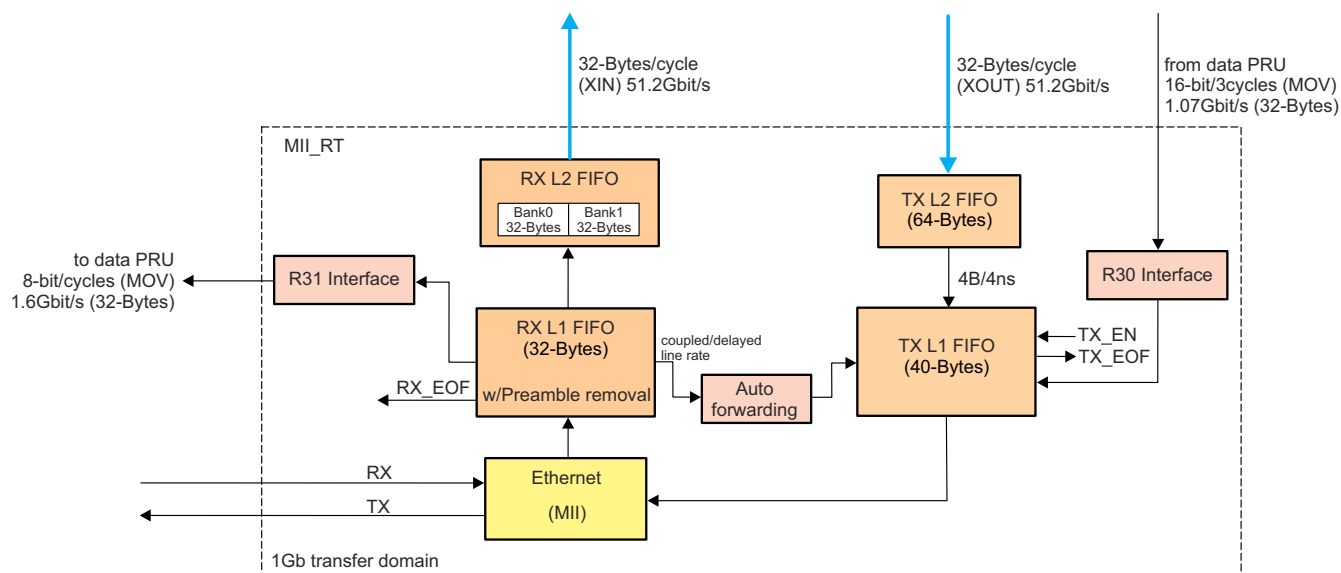

Figure 7-54. PRU-ICSS MII_RT Block Diagram

7.2.10.2 MII_RT Functional Description

7.2.10.2.1 MII_RT Data Path Configuration

The MII_RT module supports three basic data path configurations. These configurations are compared in [Table 7-73](#) and described in the following sections.

Table 7-73. MII_RT Data Path Configuration Comparison

Configuration	PRU Dependency	Data Servicing	Port-to-Port Latency
Auto-forward	Snoop only	One word in flight	Low
8- or 16-bit processing with on-the-fly modifications (RX L1)	Yes	One word or byte in flight	Low
32-byte double buffer or ping-pong processing (RX L2)	Yes	Multi-words in flight	Medium (application-dependent)

7.2.10.2.1.1 Auto-forward with Optional PRU Snoop

Data is automatically forwarded from the MII RX port to the MII TX port without manipulations, as shown in [Figure 7-55](#). This configuration does not depend on the PRU core. However, it does support an option for PRU to snoop or monitor the received data through the RX L2, shown in [Figure 7-56](#). The PRU does not access data and status bits through R31, and it does not modify and push data.



Figure 7-55. Auto-forward

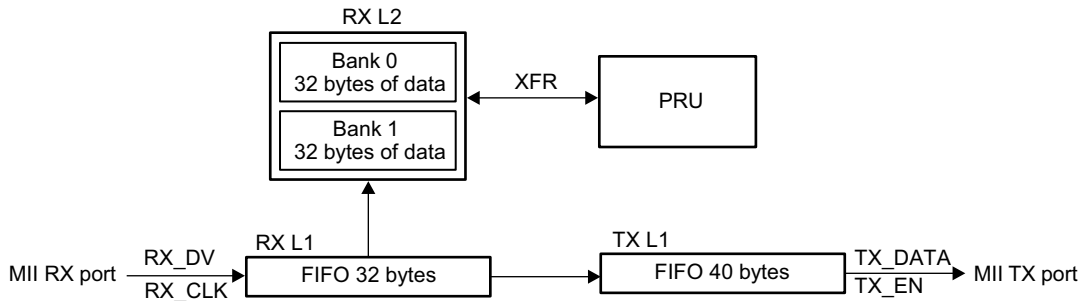

Figure 7-56. Auto-forward with PRU Snoop

7.2.10.2.1.2 8- or 16-bit Processing with On-the-Fly Modifications

This configuration services one byte or word in flight and has low latency. The PRU has the option to manipulate the received word and control popping data from the RX L1 FIFO and pushing it on the TX L1 FIFO.

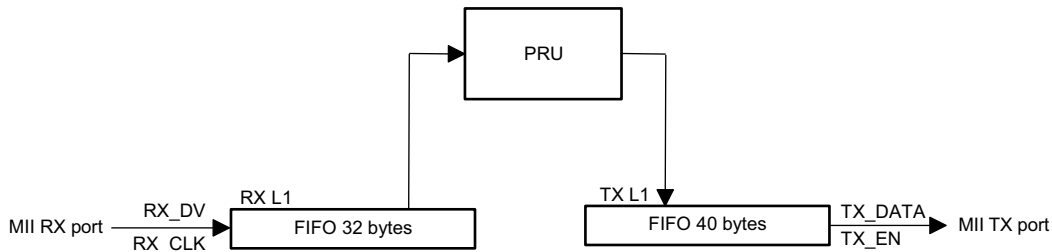

Figure 7-57. 8- or 16-bit Processing with On-the-Fly Modifications

7.2.10.2.1.3 32-byte Double Buffer or Ping-Pong Processing

This configuration supports high bandwidth, high efficiency transactions. Often implementations using this mode permit relaxed servicing requirements allowing the PRU to manipulate the received data before transmitting.

Data received in this configuration is passed into the RX L2 buffer. The PRU reads multiple bytes of data from one of the RX L2 banks through the high bandwidth broadside interface and XFR instructions. The PRU can then store or manipulate data before pushing it to the TX L1 FIFO for transmission on the MII TX port.

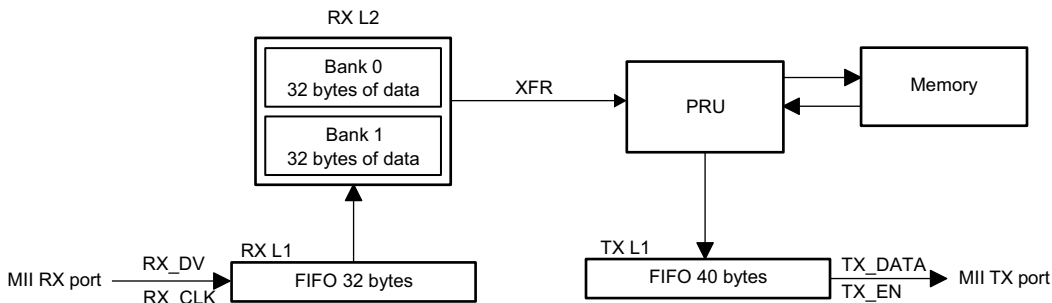

Figure 7-58. 32-byte Double Buffer or Ping-Pong Processing

7.2.10.2.2 MII_RT Definition and Terms

7.2.10.2.2.1 MII_RT Data Frame Structure

The data received and transmitted over MII conforms with the frame structure shown in Table 7-74.

Table 7-74. MII_RT Frame Structure

Inter-frame	Preamble	Start of Frame Delimiter (SFD)	Data	Cyclic Redundancy Check (CRC)
-------------	----------	--------------------------------	------	-------------------------------

The data following the SFD is formatted in a 4-bit nibble structure. Figure 7-59 illustrates the nibble order. The MSB arriving first is on the LSB side of a nibble. When receiving data, the MII_RT receive logic will wait for the next nibble to arrive before constructing a byte and delivering to the PRU.

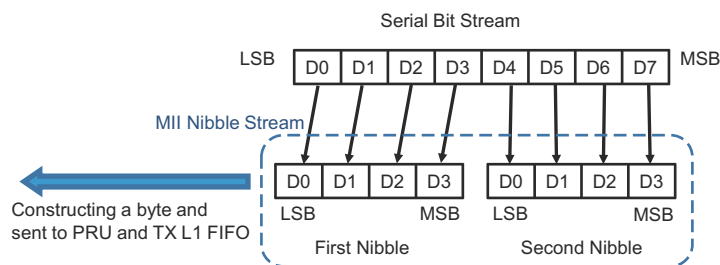

Figure 7-59. Data Nibble Structure

7.2.10.2.2.2 PRU R30 and R31

The PRU registers R30 and R31 are used to receive, transmit, and control the data for the PRU. As shown in Figure 7-60, the R31 is used to access data in the RX L1 FIFO, the R30 is used to transmit data from the PRU, and the R31 output is used to control the flow of receive and transmit. For more details about these registers, see the following sections.

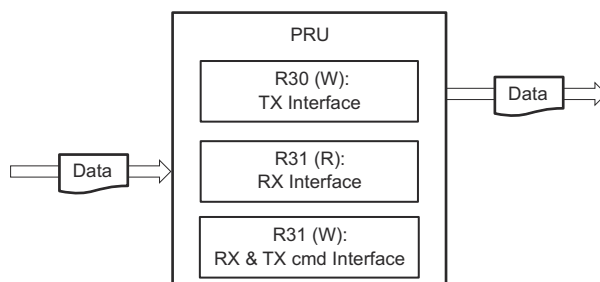

Figure 7-60. PRU R30, R31 Operations

7.2.10.2.2.3 RX and TX L1 FIFO Data Movement

To advance the next data byte seen by R31, the PRU must pop the data from the RX L1 FIFO. Likewise, the PRU can push the data from R30 to the TX L1 FIFO. These operations are illustrated in Figure 7-61.

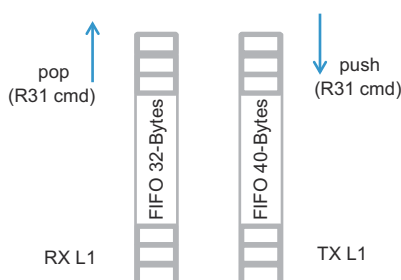

Figure 7-61. Reading and Writing FIFO Data

7.2.10.2.2.4 Receive CRC Computation

For the incoming data, the MII_RT calculates CRC32 and then compares against the value provided in the incoming frame. If there is a mismatch, the MII_RT signals ERROR_CRC to the PRU. If a previous node or Ethernet device appended an error nibble, the CRC calculation of received packet will be wrong because the longer frame and the frame length will end at a 4-bit boundary instead of the usual 8-bit boundary. When RX_DV goes inactive on the 4-bit boundary, the interface will assert DATA_RDY and BYTE_RDY flag with the ERROR_NIBBLE. The error event is also mapped into the PRU-ICSS INTC.

7.2.10.2.2.5 Transmit CRC Computation

For the outgoing data, the MII_RT calculates the CRC32 value and inserts it into outgoing packets. The CRC value computed on each MII transmit path is also available in memory map registers that can be read by the PRU and used primarily for debug and diagnostic purposes. The CRC is inserted into the outgoing packet based on the commands received through the R31 register of the PRU. The CRC will be inserted into the TX L1 FIFO, and there must be enough room to store the CRC value in the FIFO or else the FIFO will overflow. As [Table 7-75](#) shows, the CRC programming model supports three sequences that provide more flexibility. Note: “cmdR31” indicates write to the mentioned bits of the R31 command interface.

Table 7-75. TX CRC Programming Models

Option 1	Step 1: cmdR31 [TX_CRC_HIGH + TX_CRC_LOW + TX_EOF]
Option 2	<p>Note: Only valid when TX L2 is disabled.</p> <p>Step 1: cmdR31 [TX_CRC_HIGH]</p> <p>Step 2: wait > 6 clocks (PRU cycles)</p> <p>Step 3: cmdR31 [TX_CRC_LOW + TX_EOF]</p>
Option 3	<p>Note: Only valid when TX L2 is disabled.</p> <p>Step 1: cmdR31 [TX_CRC_HIGH]</p> <p>Step 2: wait > 6 clocks (PRU cycles)</p> <p>Step 3: read TX_CRC0[31-0] TX_CRC0 and TX_CRC1[31-0] TX_CRC1</p> <p>Step 4: modify CRC[15-0]</p> <p>Step 5: cmdR31 [TX_PUSH16 + TX_EOF + TX_ERROR_NIBBLE]</p>

7.2.10.2.2.6 Transmit CRC Computation for fragmented frames

Fragmented frames have a special CRC32. Each fragment CRC32 is based on the previous fragmentations, so a running total. In addition TX_CRC_HIGH is inverted for all fragments except the last fragment. The final fragmentation has a normal CRC which is based on the full frame.

7.2.10.2.3 RX MII Interface

The RX MII interface is composed of multiple components that perform various tasks - latch received data, start of frame detection, start frame delimiter detection, CRC calculation and error detection, enhanced link detection through RX error detection and interface to PRU register R31.

[Table 7-76](#) includes more details about the internal signals and output of these components

7.2.10.2.3.1 RX MII Receive Data Latch

The receive data from the MII interface is stored in the receive data FIFO which is 32 bytes. The PRU can access this data through the register R31. Depending on the configuration settings, the data can be latched on reception of one or two bytes. In each scheme, the configured number of nibbles is assembled before being copied into the PRU registers. [Figure 7-62](#) shows the inputs and outputs of the data latch logic block.

The receiver logic in MII_RT can be programmed through the MII_RT MII_RT_RXCFG0 and MII_RT MII_RT_RXCFG1 registers to remove or retain the preamble + SFD from incoming frames.

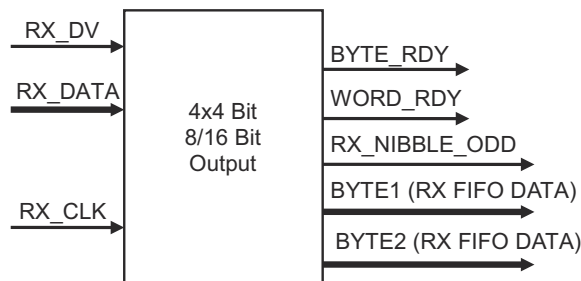

Figure 7-62. RX Data Latch

7.2.10.2.3.2 RX MII Start of Frame Detection

The start of frame detection logic tracks the frame boundaries and signals the beginning of a frame to other components of the PRU-ICSS. This logic detects two events:

- Start of Frame (SOF) event that occurs when Receive Data Valid MII signal is sampled high.
- Start of Frame Delimiter (SFD) event is seen on MII Receive Data bus.

These event triggers can be used to add timestamp to the frames. The notification for these events is available through R31 as well as through INTC which is integrated in the PRU-ICSS. [Figure 7-63](#) shows the inputs and outputs of the start of frame detection logic block.

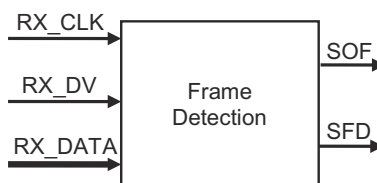

Figure 7-63. RX MII Start of Frame Detection

7.2.10.2.3.3 CRC Error Detection

For each incoming frame, the CRC is calculated by the MII_RT and compared against the CRC included in the frame. When the two values do not match, a CRC error is flagged. The ERROR_CRC indication is available in the register interface (PRU R31 Receive Interface) as well as in the FIFO interface (RX L2 Status Interface). It is also provided to the INTC which is integrated in the PRU-ICSS. [Figure 7-64](#) shows the inputs and outputs of CRC error detection logic block.

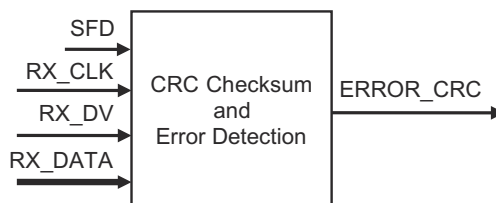

Figure 7-64. CRC Error Detection

7.2.10.2.3.4 RX Error Detection and Action

The RX error detection logic tracks the receive error signaled by the physical layer and informs the PRU-ICSS INTC whenever an error is detected. [Figure 7-65](#) shows the inputs and outputs of the RX error detection logic block. Note the following dependencies:

- RX_ERR signal is only sampled when RX_DV is asserted.
- All nibbles are discarded post RX_ERR event, including the nibble which had RX_ERR asserted. This state will remain until EOF occurs.

- Due to this fact, RX L1 FIFO and RX L2 FIFO will never receive any data with RX_ERR or post RX_ERR during that frame.

Note

RX error detection logic is supported only for MII mode and this feature is not supported for RGMII and SGMII modes of operation.

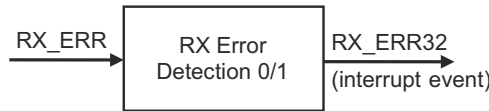
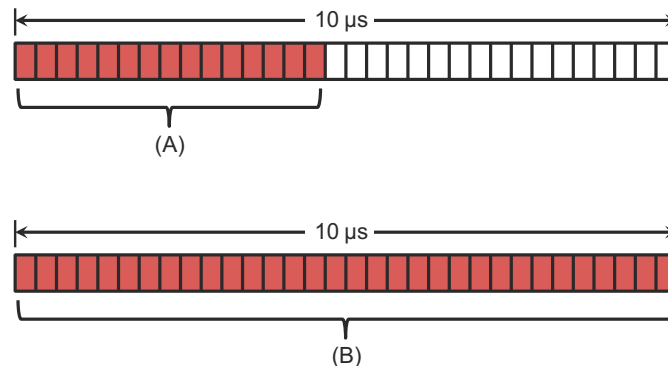

Figure 7-65. RX Error Detection

Note

Note for SGMII and RGMII modes, RX_ERR is sampled after SFD and during the payload if one occurs then it can be detected by R31 and/or INTC same as MII. The MII RX_ERR counter counts for every MII nibble.

This submodule also keeps track of a running count of receive error events within a 10 μs error detection window, as shown in Figure 7-66. The INTC is notified when 32 or more events have occurred in a 10 μs error detection window. The error detection window is not a sliding window but a non-overlapping window with no specific initialization time with respect to incoming traffic. The timer starts its 10 μs counts immediately after de-assertion of reset to the MII_RT module.



- A. There are fewer than 32 consecutive error events in the 10 μs window. The detection module will not forward to the interrupt controller (INTC).
- B. There are more or equal to 32 error events in the 10 μs window. The detection module will notify the interrupt controller (INTC).

Figure 7-66. Error Detection Window with Running Counter

7.2.10.2.3.5 RX Data Path Options to PRU

There are two data path options for delivering received data to the PRU, described further in the subsequent sections:

1. RX MII port → RX L1 FIFO → PRU (one word in flight)
2. RX MII port → RX L1 FIFO → RX L2 buffer → PRU (multi-word in flight)

Once the PRU has received RX data, the PRU can both manipulate received data or send data to the TX MII Interface.

7.2.10.2.3.6 RX MII Port → RX L1 FIFO → PRU

The RX L1 FIFO to PRU interface is depicted in Figure 7-67. In this mode, the data received from the MII interface is fed into the 32-byte RX L1 FIFO. The first data byte into the FIFO is automatically available in R31

of the PRU. Therefore, the PRU firmware can directly operate on this data without having to read it in a separate instruction. This allows the PRU to access receive data with low latency.

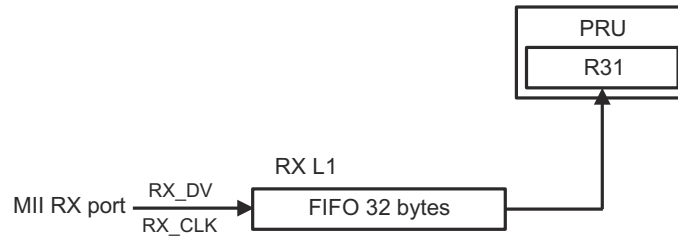

Figure 7-67. RX L1 to PRU Interface

When the new data is received, the PRU is provided with up to two bytes at a time in the R31 register, as shown in Figure 7-68. Once the PRU processes the incoming data, it instructs the MII_RT by writing to the R31 command interface bits to pop one or two bytes of data from the 32-byte RX FIFO. The pop operation causes current contents of R31 to be refreshed with new data from the incoming packet. Each time the data is popped, the status bits change to indicate so. If the pop is completed and there is no new data, the status bits immediately change to indicate no new data.

Note: The current R31 content, including data, will be lost after issuing the pop operation. If this information needs to be accessed later, the PRU should store the existing R31 content before popping new data.

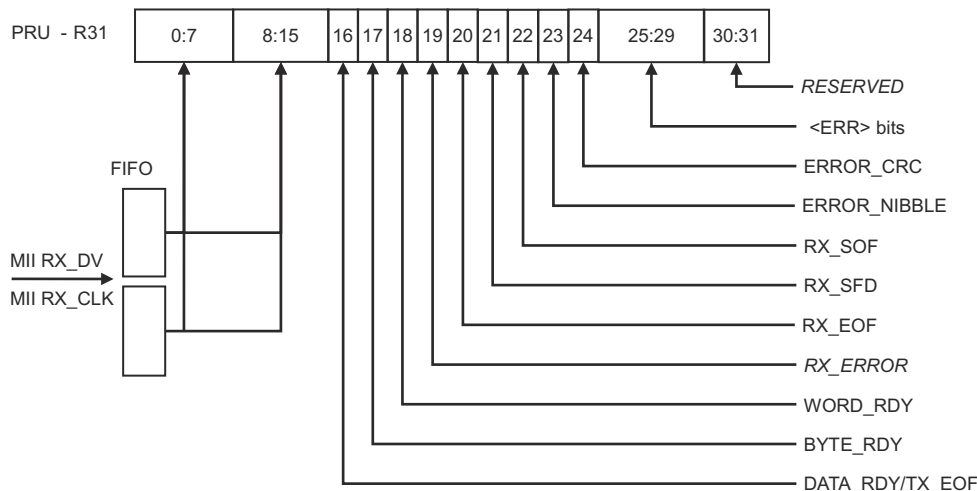

Figure 7-68. MII RX Data to PRU R31 (R) and RX FIFO

Table 7-76 describes the receive interface data and status contents provided by the R31 register. These contents are available when R31 is read. To configure this register, the PRU GPI mode should be set for MII_RT mode in the CFG register space. Note the following:

1. If the data from receive path is not read in time, it could cause an overflow event because the data is still continuously provided to the 32-byte receive FIFO. Due to the receive FIFO overflow, the data gets automatically discarded to avoid lack of space in the FIFO. At the same time, an interrupt is raised to the INTC through a system event (PRU<n>_RX_OVERFLOW). To detect an overflow condition, the PRU should poll for this system event condition and a RX RESET command through the R31 command interface is required to clear out from this condition. Note that the received Ethernet frame is corrupted and should not be used for further processing as bytes have been dropped due to the overflow condition. A FIFO reset is recommended.
2. The receive data in the R31 register is available following synchronization to the PRU clock domain. So, there is a finite delay (120 ns) when data is available from MII interface and it is accessible to the PRU.
3. The receive FIFO also has the capability to be reset through software. When reset, all contents of receive FIFO are purged and it may result in the current frame not being received as expected. When a frame

is being received and the PRU resets the RX FIFO, the remaining frame is not placed into the RX FIFO. However, any new frame arriving on the receive MII port will be stored in the FIFO.

Table 7-76. PRU R31: Receive Interface Data and Status (Read Mode)

Bits	Field Name	Description
31-30	RESERVED	In case of register interface, these bits are provided to PRU by other modules in PRU-ICSS. From the MII_RT module point of view, these bits are always zero.
29	RX_MIN_FRM_CNT_ERR	RX_MIN_FRM_CNT_ERR is set to 1 when the count of total bytes of incoming frame is less than the value defined by RX_MIN_FRM_CNT. RX_MIN_FRM_CNT_ERR is cleared by RX_ERROR_CLR. Cleared by RX_ERROR_CLR or RX_L2_DONE. Note, during backpressure the status will not get updated by a new packet in L1 FIFO. The flag is valid for the current packet in L2 FIFO.
28	RX_MAX_FRM_CNT_ERR	RX_MAX_FRM_CNT_ERR is set to 1 when the count of total bytes of incoming frame is more than the value defined by RX_MAX_FRM_CNT_ERR. RX_MAX_FRM_CNT_ERR is cleared by RX_ERROR_CLR. Cleared by RX_ERROR_CLR or RX_L2_DONE. Note, during backpressure the status will not get updated by a new packet in L1 FIFO. The flag is valid for the current packet in L2 FIFO.
27	RX_EOF_ERROR	RX_EOF_ERROR is set to 1 when an RX_EOF event or RX_ERROR event occurs. RX_EOF_ERROR is cleared by RX_EOF_CLR and/or RX_ERROR_CLR.
26	RX_MAX_PRE_CNT_ERR	RX_MAX_PRE_CNT_ERR is set to 1 when the number of nibbles equaling 0x5 before SFD event (0xD5) is more than the value defined by PRUSS_MII_RT_RX_PCNT0/1 [RX_MAX_PCNT]. RX_MAX_PRE_CNT_ERR is cleared by RX_ERROR_CLR.
25	RX_ERR	RX_ERR is set to 1 when pr1_mii0/1_rxr is asserted while pr1_mii0/1_rxdv bit is set. RX_ERR is cleared by RX_ERROR_CLR.
24	ERROR_CRC	ERROR_CRC indicates that the frame has a CRC mismatch. This bit is valid when the RX_EOF bit is set. It should be noted that ERROR_CRC bit is ready in early status, which means it is calculated before data is available in RXL1 FIFO. ERROR_CRC is cleared by RX_ERROR_CLR. Cleared by RX_ERROR_CLR or RX_L2_DONE. Note, during backpressure the status will not get updated by a new packet in L1 FIFO. The flag is valid for the current packet in L2 FIFO.
23	ERROR_NIBBLE	ERROR_NIBBLE indicates that the frame ended in odd nibble. It should be considered valid only when the RX_EOF bit and pr1_mii0/1_rxdv are set. Nibble counter is enabled post SFD event. It should be noted that ERROR_NIBBLE bit is ready in early status, which means it is calculated before data is available in RXL1 FIFO. ERROR_NIBBLE is cleared by RX_ERROR_CLR.
22	RX_SOF	RX_SOF transitions from low to high when the frame data starts to arrive and pr1_mii0/1_rxdv is asserted. Note: There will be a small sync delay of 0ns – 5ns. The recommended time to clear this bit via RX_SOF_CLR is at the end of frame (EOF). It should be noted that RX_SOF bit is ready in early status, which means it is calculated before data is available in RXL1 FIFO.
21	RX_SFD	RX_SFD transitions from low to high when the SFD sequence (0xD5) post RX_SOF is observed on the receive MII data. The recommended time to clear this bit via RX_SFD_CLR is at the end of frame (EOF). It should be noted that RX_SFD bit is ready in early status, which means it is calculated before data is available in RXL1 FIFO.
20	RX_EOF	RX_EOF indicates that the frame has ended and pr1_mii0/1_rxdv is de-asserted. It also validates the CRC match bit. Note: There will be a small sync delay of 0ns – 5ns. It should be noted that RX_EOF bit is ready in early status, which means it is calculated before data is available in RXL1 FIFO. Note: Also if RX_L2_EOF_SCLR_DIS is set, then this flag will remain asserted when RX_L2 is enabled until RX_EOF_CLR. Cleared by RX_ERROR_CLR or RX_L2_DONE. Note, during backpressure the status will not get updated by a new packet in L1 FIFO. The flag is valid for the current packet in L2 FIFO.

Table 7-76. PRU R31: Receive Interface Data and Status (Read Mode) (continued)

Bits	Field Name	Description
19	RX_ERROR	RX_ERROR indicates one or more of the following errors occurred: <ul style="list-style-type: none"> • RX_MAX/MIN_FRM_CNT_ERR • RX_MAX/MIN_PRE_CNT_ERR • RX_ERR RX_ERROR is cleared by RX_ERROR_CLR.
18	WORD_RDY	WORD_RDY indicates that all four nibbles in R31 have valid data. There is a 2 clock cycle latency from the command RX_POP16 to WORD_RDY update. Therefore, firmware needs to insure it does not read WORD_RDY until 2 clock cycles after RX_POP16.
17	BYTE_RDY	BYTE_RDY indicates that the lower two nibbles in R31 have valid data. There is a 2 clock cycle latency from the command RX_POP8 to BYTE_RDY update. Therefore, PRU firmware needs to insure it does not read BYTE_RDY until 2 clock cycles after RX_POP8.
16	DATA_RDY/ TX_EOF	When RX_DATA_RDY_MODE_DIS = 0: DATA_RDY indicates there is valid data in R31 ready to be read. This bit goes to zero when the PRU does a POP8/16 and there is no new data left in the receive MII port. This bit is high if there is more receive data for PRU to read. There is a 2 clock cycle latency from the command RX_POP16/8 to WORD_RDY/BYTE_RDY update. Therefore, PRU firmware needs to insure it does not read BYTE_RDY/WORD_RDY until 2 clock cycles after RX_POP16/8. When RX_DATA_RDY_MODE_DIS = 1: TX_EOF indicates an TX EOF event (i.e. a 1 --> 0 transition on TX_EN) has occurred. This bit will clear when TX_RESET is set or when new data is first loaded. PRU firmware can wait until TX_EOF = 1, then start a new TX Frame by immediately loading new data.
15-8	BYTE1	Data Byte 1. This data is available such that it is safe to read by the PRU when the DATA_RDY/BYTE_RDY/WORD_RDY bits are asserted.
7-0	BYTE0	Data Byte 0. This data is available such that it is safe to read by the PRU when the DATA_RDY/BYTE_RDY/WORD_RDY bits are asserted.

7.2.10.2.3.7 RX MII Port → RX L1 FIFO → RX L2 Buffer → PRU

The RX L2 is an optional high performance buffer between the RX L1 FIFO and the PRU. Figure 7-69 illustrates the receive data path using RX L2 buffer. This data path is characterized by multi-word in flight transactions.

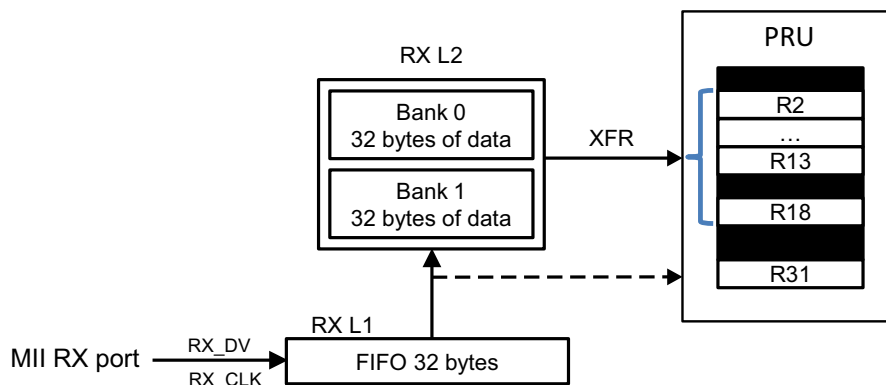

Figure 7-69. RX L2 to PRU Interface

The 64-byte RX L2 buffer is divided into two 32 byte banks, or ping/pong buffers. When the RX L2 is enabled, the incoming data from the MII RX port will transmit first to the 32 byte RX L1 FIFO. RX L1 pushes data into RX L2, starting when the first byte is ready until the final EOF marker. The RX L2 buffer will apply backpressure to the RX L1 FIFO after RX_L2_EOF event occur and until RX_L2_DONE event. Therefore, it is the PRU firmware’s responsibility to fetch the data in RX L2 before it is overwritten by the cyclic buffer. The RX L1 will remain near empty, with only one byte (nibble) stored.

Each RX L2 bank holds up to 32 bytes of data, and every four nibbles (or 16 bits) of data has a corresponding 8-bit status. The data and status information are stored in packed arrays. In each bank, R2 to R9 contains the data packed array and R10 to R13 contains the status packed array. Figure 7-70 shows the relationship of the data registers and status registers. The RX L2 status registers record status information about the received data, such as ERROR_CRC, RX_ERROR, STATUS_RDY, etc. The RX L2 status register details are described in Table 7-77. Note: RX_RESET clears all Data and Status elements and resets R18.

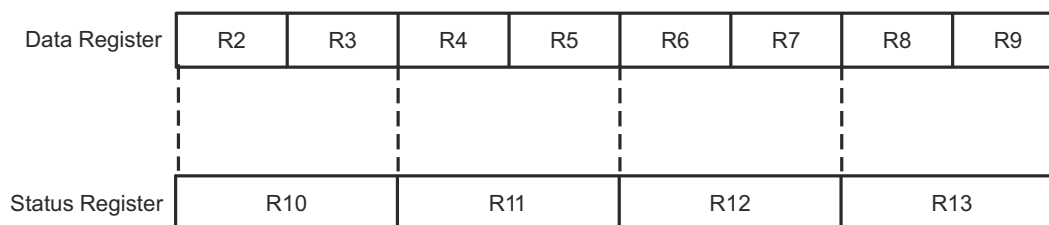

Figure 7-70. Data and Status Register Dependency

7.2.10.2.3.7.1 RX L2 Status in mode 0, none IET mode (when ICSS_M_CFG[2] RX_L2_G_EN= 0h)

Table 7-77. RX L2 Status in mode 0

Bit	Field Name	Description
7	ERROR_CRC	ERROR_CRC indicates that the frame has a CRC mismatch. This bit is valid when the RX_EOF bit is set. It should be noted that ERROR_CRC bit is ready in early status, which means it is calculated before data is available in RX L1 FIFO. ERROR_CRC will only be set for one entry, self clear on next entry.
6	ERROR_NIBBLE	ERROR_NIBBLE indicates that the frame ended in odd nibble. It should be considered valid only when the RX_EOF bit and pr1_mii0/1_rxdv are set. Nibble counter is enabled post SFD event. It should be noted that ERROR_NIBBLE bit is ready in early status, which means it is calculated before data is available in RX L1 FIFO. ERROR_NIBBLE will only be set for one entry, self clear on next entry.
5	RX_SOF	RX_SOF transitions from low to high when the frame data starts to arrive and pr1_mii0/1_rxdv is asserted. Note: There will be a small sync delay of 0ns – 5ns. It should be noted that RX_SOF bit is ready in early status, which means it is calculated before data is available in RX L1 FIFO. RX_SOF will only be set for one entry, self clear on next entry.
4	RX_SFD	RX_SFD transitions from low to high when the SFD sequence (0xD5) post RX_SOF is observed on the receive MII data. It should be noted that RX_SFD bit is ready in early status, which means it is calculated before data is available in RX + L1 FIFO. RX_SOF will only be set for one entry, self clear on next entry.
3	RX_EOF	RX_EOF indicates that the frame has ended and pr1_mii0/1_rxdv is de-asserted. It also validates the CRC match bit. Note: There will be a small sync delay of 0ns – 5ns. It should be noted that RX_EOF bit is ready in early status, which means it is calculated before data is available in RX L1 FIFO. If RX_L2_EOF_SCLR_DIS = 1, then RX_EOF will remain set until RX_EOF_CLR event. Otherwise, RX_ERROR is self-clearing on next entry.
2	RX_ERROR	RX_ERROR indicates one or more of the following errors occurred: <ul style="list-style-type: none"> • RX_MAX/MIN_FRM_CNT_ERR • RX_MAX/MIN_PRE_CNT_ERR • RX_ERR RX_ERROR is cleared by RX_ERROR_CLR.
1	STATUS_RDY	STATUS_RDY is set when RX_EOF or write pointer advanced by 2. This is a simple method for software to determine if RX_EOF event has occurred or new data is available. If RX_EOF is not set, all status bits are static.

Table 7-77. RX L2 Status in mode 0 (continued)

Bit	Field Name	Description
0	RX_ERR	RX_ERR is set to 1 when pr1_mii0/1_rxr is asserted while pr1_mii0/1_rxdv bit is set. It will get set for first pr1_mii0/1_rxr event and self clear on SOF for the next FRAME.

7.2.10.2.3.7.2

Bank 0 and Bank 1 are used as ping/pong buffers. RX L2 supports the reading of a write pointer in R18 that allows software to determine which bank has active write transactions, as well as the specific write address within packed data arrays.

The PRU interacts with the RX L2 buffer using the high performance XFR read instructions and broadside interface. [Table 7-78](#) shows the device XFR ID numbers for each bank.

Table 7-78. RX L2 XFR ID

Device ID	Function	Description
20	Selects RX L2 Bank0	R2:R9 Data packed array R10:R13 Status packed array mode 0
21	Selects RX L2 Bank1	R2:R9 Data packed array R10:R13 Status packed array mode 0
20/21	Byte pointer of current write	R18[5-0] Pointer indicating location of current write in data packed array. 0 = Bank0.R2.Byte0 (default and reset value) 1 = Bank0.R2.Byte1 2 = Bank0.R2.Byte2 3 = Bank0.R2.Byte3 4 = Bank0.R3.Byte0 ... 63=Bank1.R9.Byte3

7.2.10.2.3.7.3

XFR read transactions are passive and have no effect on any status or other states in RX L2. The firmware can also read R18 to determine which Bank has active write transactions and the location of the transaction. With this information, the firmware can read multiple times the stable preserved data. Note: When RX L1 data is written to RX L2, the next status byte gets cleared at the same time the current status byte gets updated. The rest of the status buffer is persistent. When software is accessing any register of the ping/ pong buffer, software needs to issue an XFER read transaction to fetch the latest/current state of the ping/pong buffer. The PRU registers will not reflect the current snapshot of L2 unless an XFER is issued by software.

7.2.10.2.3.7.4 Broadside Stitch FIFO

A simple 2 deep by 32 Byte Wide broadside FIFO is attached to ID = 08 to enable the firmware to efficiently pack fragments into aligned data words.

Table 7-79. RX L2 XFR ID

Device ID	Function	Description
08	64 Bytes XOUT 1 Byte to 32 Bytes, LSB justify XIN 32 Bytes. Note: FIFO has less than 32 Bytes, it will only return the valid data LSB justified	R2:R9 Data packed array
08	It will subtract 4 bytes from the current wr_ptr	R10[0] Control
08	It will reset the rd and wr ptrs	R10[1] Reset

7.2.10.2.4 PRU-ICSS TX MII Interface

The PRU core directly drives the MII transmit interface via its R30 internal register. The contents of R30 register and RX Data from receive interface are taken and fed into a transmit FIFO (TX L2 FIFO - 64 Bytes).

Data to be transmitted is loaded into the TX L1 FIFO. The transmit FIFO (TX L1) stores up to 40 Bytes of transmit data. Note that this includes the preamble bytes. From the transmit FIFO (TX L1), the data is sent to the MII TX port of the PHY by the MII_RT transmit logic.

The transmit FIFO also has the capability to be reset through software (TX_RESET). When reset, all contents of transmit FIFO are purged and this may result in a frame not getting transmitted as expected, if the transmission is already ongoing. Any new data written in the transmit FIFO results in a new frame being composed and transmitted. An overflow event will require a TX_RESET to recover from this condition.

There are four dependencies that must be true for TX_EN to assert:

1. TX L1 FIFO not empty
2. Interpacket gap (IPG) timer expiration
3. RX_DV to TX_EN timer expiration
4. TX_EN compare timer expiration

The transmit interface also provides an underflow error signal in case there was no data loaded when TX_EN triggered. The transmit underflow signal is mapped to the INTC in PRU-ICSS. The current FIFO fill level cannot be accessed by PRU firmware. The firmware can issue an R31 command via R31 bit 29 (TX_EOF) to indicate that the last byte has been written into the TX FIFO.

7.2.10.2.4.1 TX Data Path Options to TX L1 FIFO

There are two data path options for delivering data to the TX L1 FIFO and transmit port, described further in the subsequent sections:

1. PRU → TX L1 FIFO → TX MII port
2. RX L1 FIFO → TX L1 FIFO → TX MII port

7.2.10.2.4.1.1 PRU → TX L1 FIFO → TX MII Port

The PRU can be used to feed data into the TX L1 FIFO using the R30 and R31 registers, shown in Figure 7-71. The PRU has the option to write up two or four bytes of R30 and then pushes the data into the TX L1 FIFO by writing to the R31 command interface.

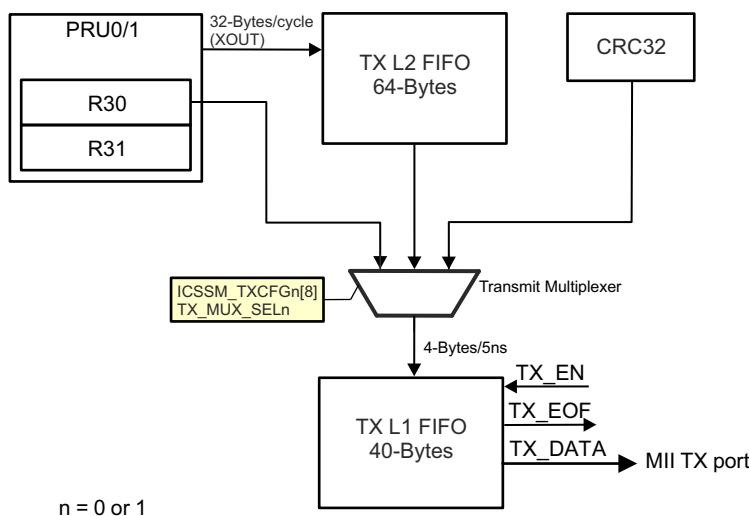

Figure 7-71. PRU to TX L1 FIFO Interface

7.2.10.2.4.1.1.1 TX L2 FIFO Features

- 64-Bytes deep TX L2 FIFO which feeds data into a 40-Bytes deep TX L1 FIFO

- Maximum of 64-Bytes Broad Side load, minimum of 1-Byte Broad Side load, R2.b0(start)
- **Note: MII_RT_TXCFG0/1[3] TX_BYTE_SWAPn bit (where n = 0 or 1) is not supported for TX L2 FIFO.**
- FIFO level status available through MII_RT_TX_FIFO_LEVEL0[7-0] TX_FIFO_LEVEL0 and MII_RT_TX_FIFO_LEVEL1[7-0] TX_FIFO_LEVEL1 registers
- 2 FIFO threshold events: 32-Bytes (available and empty) or 64-Bytes (available)
- Total bytes sent for a current/last frame is available for software
- New frame can start after TX L2 FIFO is empty, but before TX L1 FIFO is empty from an old frame
 - **Note: Only supported for RGMII and SGMII modes of operation**
 - New frame can start after 5 or more core clock cycles after it is drained, this is required to finish the CRC for the first frame

Table 7-80. TX L2 XFR Mapping

Device ID	Function	Description
40	Data	R17:R2 Data, XOUT Only 1-Byte to 64-Bytes in size LSB packed and no gaps, for example 64-Bytes push R17:R2 32-Bytes push R9:R2 16-Bytes push R5:R2 4-Bytes push R2 7-Bytes push R3(b2.b0):R2 1-Bytes push R2(b0) Can do back to back
40	Control	Control of TX L2 FIFO
40	Status	Status of TX L2 FIFO

Table 7-81. TX L2 Control

BS ID	BS R	Bit	Name	Type	Reset	Description
40	R18	1-0	TAG insertion mode	WO	0h	Sets the TAG mode for next frame or current frame. It will have a one time action per frame. After action, software must rearm for a new action 1 cmd per packet. MII_RT_TXCFG0/1[1] TX_AUTO_PREAMBLEn bit (where n = 0 or 1) must be set to 1h. Note: This bit is self cleared.
40	R18	2	VLAN removal	WO	0h	If set, it will remove 4-Bytes of VLAN. This is only valid when TX L2 FIFO is enabled through ICSS_M_CFG[1] TX_L2_ENABLE bit (value 1h) and MII_RT_TXCFG0/1[1] TX_AUTO_PREAMBLEn = 1h (where n = 0 or 1) then Byte13, Byte14, Byte15, Byte16 will get removed. Note: Byte1 is the first byte which is pushed by PRU core. Note that the first 2 bytes of the VLAN must match the value in MII_RT_TX_VLAN_TYPE_TAG_PORT0/1[15-0] TX_VLAN_TYPE_TAG bit field (reset state is 81h). If not, the 4-Bytes will NOT get removed. A RXVLANRemoval flag will get set if the action occurred Allow all combos of TAG + VLAN IN. Note: This will be defined in a matrix. Note: This bit is self cleared.

Table 7-81. TX L2 Control (continued)

BS ID	BS R	Bit	Name	Type	Reset	Description
40	R18	4	EXP_FRAME	WO	0h	<p>Must be set for all EXP_FRAME. We have 3 types of frames:</p> <ul style="list-style-type: none"> Implicit EXP_FRAME not set PRE_FRAME Not set SMD == 0xd5 EXP_FRAME (use a SMD_EXP) EXP_FRAME set PRE_FRAME not set. <p>PRE_FRAME (use MII_RT_SMDT1S_CFG .SMDT1S_n for initial and MII_RT_SMDT1C_CFG .SMDT1C_n + MII_RT_FRAG_CNT_CFG .FRAG_CNT_n for non initial) EXP_FRAME set PRE_FRAME not set. Note: This bit is self cleared on EOF.</p>
40	R18	6	RESERVED	R	0h	Reserved
40	R18	7	EOF_MCRC_REQ	WO		<p>Set this bit before TX L1 FIFO is empty to generate a MCRC vs CRC.</p> <p>Note: This bit is self cleared on EOF.</p>
40	R18	11-8	RESERVED	R	0h	Reserved

Table 7-82. TX L2 Status

BS ID	BS R	Bit	Name	Type	Reset	Description
40	R19	11-0	TXL2ByteSentCount	R	0h	This bit field defines the number of bytes transmitted to TX L1 FIFO. The count will remain persistent until the next frame starts. This will get used to determine the number of bytes which got transmitted after a Preemption event. This includes all data pushed by the PRU core, which did get transmitted. It does not include the CRC.
40	R19	12	RESERVED	R	0h	Reserved
40	R19	13	RXVLAN Removal	R/W1C	0h	This bit will be set when VLAN removal occurred. VLAN removal will only occur if TPID value is equal to the value in MII_RT_TX_VLAN_TYPE_TAG_PORT0/1[15-0] TX_VLAN_TYPE_TAG bit field (reset state is 81h). Software can clear sticky used for debug.
40	R19	14	RESERVED	R	0h	Reserved
40	R19	15	RESERVED	R	0h	Reserved
40	R19	22-16	TXL2Occ	R	0h	<p>This bit field defines the current number of bytes in TX L2 FIFO.</p> <p>0h: 0 bytes, or empty FIFO buffer 1h: 1 byte ... 64h = 64 bytes, or full FIFO buffer</p>

Table 7-83. TX L2 TAG Modes

TAG Mode	At	What to Push/Add to the Frame
0	None	Nothing
1	Push TAG1	<p>Byte 13 = VLAN_PORT<1/0>[7-0] Byte 14 = VLAN_PORT<1/0>[15-8] Byte 15 = VLAN_PORT<1/0>[23-16] Byte 16 = VLAN_PORT<1/0>[31-24] Used for Host. Host -> PRU-ICSS -> add VLAN TAG -> Port SFD offset issues</p>

Table 7-83. TX L2 TAG Modes (continued)

TAG Mode	At	What to Push/Add to the Frame
2	Push TAG2	Byte 13 = HTAG_PORT<1/0>[7-0] Byte 14 = HTAG_PORT<1/0>[15-8] Byte 15 = HTAG_PORT<1/0>[23-16] Byte 16 = HTAG_PORT<1/0>[31-24] Byte 17 = SEQ_PORT<1/0>[7-0] Byte 18 = SEQ_PORT<1/0>[15-8]
3	Push TAG3	Byte 13 = VLAN_PORT<1/0>[7-0] Byte 14 = VLAN_PORT<1/0>[15-8] Byte 15 = VLAN_PORT<1/0>[23-16] Byte 16 = VLAN_PORT<1/0>[31-24] Byte 17 = HTAG_PORT<1/0>[7-0] Byte 18 = HTAG_PORT<1/0>[15-8] Byte 19 = HTAG_PORT<1/0>[23-16] Byte 20 = HTAG_PORT<1/0>[31-24] Byte 21 = SEQ_PORT<1/0>[7-0] Byte 22 = SEQ_PORT<1/0>[15-8]

7.2.10.2.4.1.1.2 TX Insertion

There are 3 TAG Insertion modes that software can select. Note that the mode must be selected before the first byte is pushed into the TX FIFO. The values, pushed into the TX FIFO are defined in the MII_RT_TX_FIFO_LEVEL0/1[7-0] TX_FIFO_LEVELn registers (where n = 0 or 1).

Table 7-84. TX VLAN_TAG Cases

Case	RM VLAN	ADD VLAN	ADD HSR	In packet	Out packet
1	1	0	0	If pkt[B13:B14] == vlan_type_id	B16, B15, B14, B13 will be removed. If packet is less than 64-Bytes, 0s will get added before the CRC.
2	1	0	0	If pkt[B13:B14] != vlan_type_id	No effect.
3	0	1	0	X	VLAN_TAG added 4-Bytes. Start B13.
4	0	0	1	X	HSR_TAG added 6-Bytes. Start B13.
5	0	1	1	X	VLAN+TAG and HSR_TAG added 10-Bytes. Start B13.
6	1	1	0	If pkt[B13:B14] == vlan_type_id	B16, B15, B14, B13 will be replaced with VLAN_TAG.
7	1	1	0	If pkt[B13:B14] != vlan_type_id	No effect.
8	1	1	1	If pkt[B13:B14] == vlan_type_id	B16, B15, B14, B13 will be replaced with VLAN_TAG. Then HSR_TAG will be added.
9	1	1	1	If pkt[B13:B14] != vlan_type_id	No effect.
10	1	0	1	If pkt[B13:B14] = vlan_type_id	B16, B15, B14, B13 will be removed and HSR_TAG added 6-Bytes. Start B13.
11	1	0	1	If pkt[B13:B14] != vlan_type_id	HSR_TAG added 6-Bytes. Start B13

7.2.10.2.4.1.1.3 TX Preemption

Case 1) Preemptible frame which got fragmented.

1. Idle -> preemptible frame when:
 - PRE_FRAME is set before first data push
2. preemptible -> frag when
 - EOF_MCRC_REQ is set after the last data is pushed into TX L2 FIFO and before TX L1 FIFO is empty

3. frag -> frag when
 - PRE_FRAME is set before first data push and EOF_MCRC_REQ is set after the last data is pushed into TX L2 FIFO and before TX L1 FIFO is empty
4. frag -> lfrag when:
 - PRE_FRAME is set before first data push and TX_EOF_REQ set after the last data is pushed into TX L2 FIFO and before TX L1 FIFO is empty
5. lfrag -> Idle when CRC is pushed into TX L1 FIFO

Case 2) Preemptible frame which did not get fragmented.

1. Idle -> preemptible frame when:
 - PRE_FRAME is set before first data push
2. preemptible -> Idle when
 - TX_EOF_REQ is set before TX L1 FIFO is empty

Note: Express frames can and will occur between the fragments.

Rules:

- Preemptible must get set before the first data is pushed into TX L2 FIFO
- EOF_MCRC_REQ is set after the last data is pushed into TX L2 FIFO and before TX L1 FIFO is empty
- TX_EOF_REQ can only get asserted on the last frag or preemptible frame which did not get fragmented. It can not get asserted in none last fragments.

Note: TX_EOF_REQ can not get asserted when EOF_MCRC_REQ is asserted.

2.10.2.4.1.3.1 TX Preemption Programming Model

Start a new frame.

1. Wait until R31.TX_EOF event
2. Load data into TX L2 FIFO until the full frame is completed
3. Issue a R30.TX_EOF + TX_CRC_HIGH + TX_CRC_LOW

Figure 7-72 shows the R30 transmit interface. The lower 16 bits of the R30 (or FIFO transmit word) contain transmit data nibbles. When MII_RT_TXCFG0/1[11] TX_32_MODE_ENn = 0h - default value (where n = 0 or 1), then the upper 16 bits contain mask information. Alternatively, when MII_RT_TXCFG0/1[11] TX_32_MODE_ENn = 1h (where n = 0 or 1), then the upper 16 bits contain transmit data nibbles. The operation to be performed on the transmit interface is controlled by PRU writes to the R31 command interface. Table 7-85 describes the supported configurations for 8, 16, and 32 bit TX push operations.

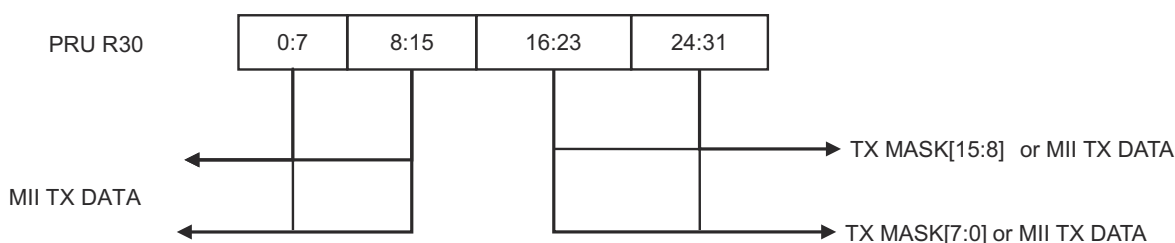

Figure 7-72. PRU to TX MII Interface

Table 7-85. TX Push

R31[25] TX_PUSH16/32	R31[24] TX_PUSH8/32	Supported R30 bits	TX_32_MODE_EN	TX_BYTE_SWAP	TX Push Action
0	1	X	0	X	8 bits of TXDATA (R30[7-0]) pushed post TX mask
1	0	X	0	X	16 bits of TXDATA (R30[15-0]) pushed post TX mask
1	1	X	0	X	Illegal

Table 7-85. TX Push (continued)

R31[25] TX_PUSH16/32	R31[24] TX_PUSH8/32	Supported R30 bits	TX_32_MODE_EN	TX_BYTE_SWAP	TX Push Action
X	X	0x000000FF	1	0	8 bits of TXDATA (R30[7-0]) pushed
X	X	0x0000FFFF	1	0	16 bits of TXDATA (R30[15-0]) pushed
X	X	0xFFFFFFFF	1	X	32 bits of TXDATA (R30[31-0]) pushed
X	X	All other - reserved	1	X	Reserved

Using MII_RT_TXCFG0/1[11] TX_32_MODE_ENn = 0h and the TX mask, the PRU can send a mix of R30 and RX L1 FIFO data to the TX L1 FIFO. Note the TX mask is only available when the PRU is fed one word or byte at a time by the RX L1 FIFO. It is not applicable when the RX L2 buffer is enabled. To disable TX mask, set TXMASK to 0xFFFF.

As shown in Figure 7-73, the PRU drives the MII transmit interface through its R30 register. The contents of R30 and RX data from the receive interface (RX L1 FIFO) are taken and fed into a 40-Bytes transmit FIFO (TX L1 FIFO).

If MII_RT_TXCFG0/1[11] TX_32_MODE_ENn = 0h (where n = 0 or 1), then before transmission, a mask is applied to the data portion of the R30 register. By using the mask, the PRU firmware can control whether received data from the RX L1 FIFO is sent to transmit, R30 data is sent to transmit, or a mix of the two is sent. The Boolean equation that is used by MII_RT to compose TX data is:

$$TXDATA[7/15-0] = (R30[7/15-0] \& MASK[7/15-0]) \mid (RXDATA[7/15-0] \& \sim MASK [7/15-0])$$

As shown in the equation, a mask of FFh will lead to the R30[7:0] being transmitted in an 8-bit transmit operation. A mask of 0h will lead to receive data being sent out in a 16-bit transmit operation.

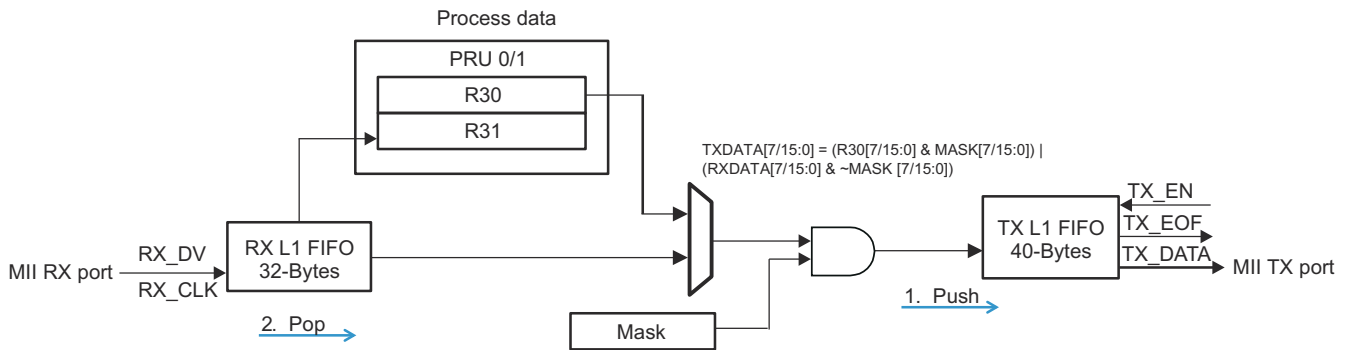

Figure 7-73. TX Mask Mode (MII_RT_TXCFG0/1[TX_32_MODE_ENn] = 0h)

7.2.10.2.4.1.2 RX L1 FIFO → TX L1 FIFO (Direct Connection) → TX MII Port

When MII_RT_TXCFG0/1[9] PRE_TX_AUTO_SEQUENCEEn is set to 1h (where n = 0 or 1), the data frame is passed from the RX L1 FIFO to TX L1 FIFO without any interaction of the PRU. This mode of operations is shown in Figure 7-74. The RX L1 FIFO will push data into TX L1 FIFO as long as it is enabled and not full.

There is no PRU dependency in this mode and no option for the PRU to perform any operation to the TX L1 FIFO. RX_RESET clears all data and status elements.

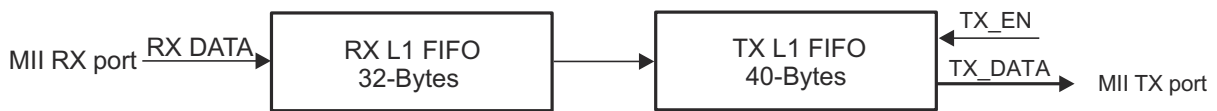

Figure 7-74. RX L1 to TX L1 Interface

For ESC protocols, software should enable [6]RX_AUTO_FWD_PRE0/1 and [4]RX_L2_EN0/1 bits in MII_RT_RXCFG0/1 registers.

For non ESC protocols, software can enable MII_RT_TXCFG0/1[1] TX_AUTO_PREAMBLEn and MII_RT_RXCFG0/1[2] RX_CUT_PREAMBLEn bit (where n = 0 or 1) to insure full preamble is generated for each TX frame.

The PRU core can read the passing through frame by polling the standard R31 register. In Direct mode, the PRU R31 Command is ignored and disabled, except for TX_RESET and RX_RESET.

The following are the legal configurations supported for Direct Connection:

- Configuration 1:
 - PORT1.RX -> PRU1 (snoop only)
 - PORT1.RX -> PORT0.TX
- Configuration 2:
 - PORT0.RX -> PRU0 (snoop only)
 - PORT0.RX -> PORT1.TX
- Configuration 3:
 - PORT1.RX -> PORT1.TX
- Configuration 4:
 - PORT0.RX -> PORT0.TX

7.2.10.2.5 PRU R31 Command Interface

The PRU uses writes to R31[31-16] to control the reception and transmission of packets in direct and register mode. [Table 7-86](#) lists the available commands. Each bit in the table is a single clock pulse output from the PRU. When more than one action is to be performed in the same instant, the PRU firmware must set those command bits in one instruction.

Table 7-86. PRU R31: Command Interface (Write Mode)

Bit	Command	Description
31	TX_CRC_ERR	TX_CRC_ERR command when set will add 0xA5 byte to the TX L1 FIFO if the current FCS is valid. This bit can only be set with the TX_EOF command and optionally with the TX_ERROR_NIBBLE command. It cannot get set with any other commands, and the PRU firmware must wait > 2 clocks from the last command. Note: For proper operations auto-forward preamble must be enabled.
30	TX_RESET	TX_RESET command is used to reset the transmit FIFO and clear all its contents. This is required to recover from a TX FIFO overrun.
29	TX_EOF	TX_EOF command is used to indicate that the data loaded is considered last for the current frame
28	TX_ERROR_NIBBLE	TX_ERROR_NIBBLE command is used to insert an error nibble. This makes the frame invalid. Also, it will add 0x0 after the 32-bit CRC.
27	TX_CRC_HIGH	TX_CRC_HIGH command ends the CRC calculations and pushes CRC[31-16] to append to the outgoing frame in the TX L1 FIFO. Note: TX_CRC0/1 will become valid after 6 clock cycles.
26	TX_CRC_LOW	TX_CRC_LOW command pushes CRC[15-0] to append to the outgoing frame in the TX L1 FIFO.
25	TX_PUSH16	TX_PUSH16 command pushes R30[15-0] when MII_RT_TXCFG0/1[11] TX_32_MODE_ENn = 0h (where n = 0 or 1). See Table 7-85, TX Push for more details. Note: There are no restrictions on concurrent PUSH/POP nor R30 requirements to maintain data. Back to back PUSH is supported.
24	TX_PUSH8	TX_PUSH8 command pushes R30[7-0] when MII_RT_TXCFG0/1[11] TX_32_MODE_ENn = 0h (where n = 0 or 1). See Table 7-85, TX Push for more details. Note: There are no restrictions on concurrent PUSH/POP nor R30 requirements to maintain data. Back to back PUSH is supported.
23	RX_ERROR_CLR	RX_ERROR_CLR command is used to clear RX_ERROR indicator bit by writing 1h.

Table 7-86. PRU R31: Command Interface (Write Mode) (continued)

Bit	Command	Description
22	RX_EOF_CLR	RX_EOF_CLR command is used to clear RX_EOF status indicator bit by writing 1h.
21	RX_SFD_CLR	RX_SFD_CLR command is used to clear RX_SFD indicator bit by writing 1h.
20	RX_SOF_CLR	RX_SOF_CLR command is used to clear RX_SOF indicator bit by writing 1h.
19	Reserved	Reserved
18	RX_RESET	RX_RESET is used to reset the receive FIFO and clear all contents. This is required to recover from a RX FIFO overrun, if software does not want to undrain. The typical use case is assertion after RX_EOF. If asserted during an active frame, the following actions will occur: <ol style="list-style-type: none"> 1. Terminate the current frame 2. Block/terminate all new data 3. Flush/clear all FIFO elements 4. Cause RX state machine into an idle state 5. Cause EOF event 6. Cause minimum frame error, if you abort before minimum size reached
17	RX_POP16	RX_POP16 command advances the receive traffic by two bytes. This is only required when you are using R31 to read the data. After R31[15-0] is ready to read by PRU, it will set 1h to WORD_RDY, and the next new data will be allowed to advance. RX_POP16 to WORD_RDY update has 2 clock cycles latency. Firmware needs to insure it does not read WORD_RDY/BYTE_RDY until 2 clock cycles after RX_POP16.
16	RX_POP8	RX_POP8 command advances the receive traffic by one bytes. This is only required when you are using R31 to read the data. After R31[7-0] is ready to read by PRU, it will set 1h to BYTE_RDY, and the next new data will be allowed to advance. RX_POP8 to BYTE_RDY update has 2 clock cycles latency. Firmware needs to insure it does not read WORD_RDY/BYTE_RDY until 2 clock cycles after RX_POP8.

7.2.10.2.6 Other Configuration Options

7.2.10.2.6.1 Nibble and Byte Order

The PRU core is little endian. To support big endian, the MII_RT supports optional nibble swapping on both the RX and TX side.

On the receive side, the order of the two data bytes in RX R31 and the RX L2 buffer are configurable through the RX_BYTE_SWAP0/1 bit in the MII_RT_RXCFG0/1 registers, as shown in [Table 7-87](#). Note: The Nibble0 is the first nibble received.

Table 7-87. RX Nibble and Byte Order

Configuration	Order
MII_RT_RXCFG0/1[5] RX_BYTE_SWAPn = 0h (default), where n = 0 or 1	R31[15-8] / RXL2[15-8] = Byte1{Nibble3, Nibble2} R31[7-0] / RXL2[7-0] = Byte0{Nibble1, Nibble0}
MII_RT_RXCFG0/1[5] RX_BYTE_SWAPn = 1h, where n = 0 or 1	R31[15-8] / RXL2[15-8] = Byte0{Nibble1, Nibble0} R31[7-0] / RXL2[7-0] = Byte1{Nibble3, Nibble2}

On the transmit side, the order of the two data bytes and mask bytes in TX R30 are configurable through the TX_BYTE_SWAP0/1 bit in the MII_RT_TXCFG0/1 registers, as shown in [Table 7-88](#). Note the Nibble0 is the first nibble transmitted.

Table 7-88. TX Nibble and Byte Order

Configuration	Order
MII_RT_TXCFG0/1[3] TX_BYTE_SWAPn = 0h (default), where n = 0 or 1	If MII_RT_TXCFG0/1[11] TX_32_MODE_ENn = 0h, where n = 0 or 1 R30[15-8] = Byte1{Nibble3, Nibble2} R30[7-0] = Byte0{Nibble1, Nibble0} R30[31-24] = TX_MASK[15-8] R30[23-16] = TX_MASK[7-0] If MII_RT_TXCFG0/1[11] TX_32_MODE_ENn = 1h, R30[31-24] = Byte3{Nibble7, Nibble6} R30[23-16] = Byte2{Nibble5, Nibble4} R30[15-8] = Byte1{Nibble3, Nibble2} R30[7-0] = Byte0{Nibble1, Nibble0}
MII_RT_TXCFG0/1[3] TX_BYTE_SWAPn = 1h, where n = 0 or 1	If MII_RT_TXCFG0/1[11] TX_32_MODE_EN = 0h, R30[15-8] = Byte0{Nibble1, Nibble0} R30[7-0] = Byte1{Nibble3, Nibble2} R30[31-24] = TX_MASK[7-0] R30[23-16] = TX_MASK[15-8] If MII_RT_TXCFG0/1[11] TX_32_MODE_EN = 1h, Only 32-bit push is supported. R30[31-24] = Byte0{Nibble1, Nibble0} R30[23-16] = Byte1{Nibble3, Nibble2} R30[15-8] = Byte2{Nibble5, Nibble4} R30[7-0] = Byte3{Nibble7, Nibble6}

7.2.10.2.6.2 MII_RT Preamble Source

The MII_RT module has the option to preserve and forward a received preamble in the TX data stream, use a preamble provided by the PRU, or auto-generate a preamble. These configurations are highlighted in [Table 7-89](#).

Table 7-89. Preamble Configuration Options

RX_CUT_PREAMBLE	Determines whether RX preamble is passed to the RX L1/L2 FIFO
RX_AUTO_FWD_PRE	Determines whether RX preamble is automatically passed to TX L1 FIFO
TX_AUTO_PREAMBLE	TX interface logic auto-generates and appends preamble to TX data stream with the first push of data into the TX L1 FIFO. Note that enabling this option does fill the TX FIFO with the preamble length, hence software has to consider this to not overrun the TX FIFO.

7.2.10.2.6.3 PRU and MII Port Multiplexer

The MII_RT module supports configurable PRU core to MII TXn / RXn port mapping. By default, PRU0 is mapped to TX1 and RX0 and PRU1 is mapped to TX0 and RX1. However, the system supports the flexibility to map any PRU core to any TX and RX port. For example, the input to PRU0 can be either RX_MII0 or RX_MII1. Similarly, the input to TX_MII0 can be either PRU0 or PRU1.

7.2.10.2.6.3.1 Receive Multiplexer

A multiplexer is provided to allow selecting either of the two MII interfaces (RX_MII0 or RX_MII1) for the receive data that is sent to PRU. [Figure 7-75](#) shows a simple diagram of PRU receive multiplexer.

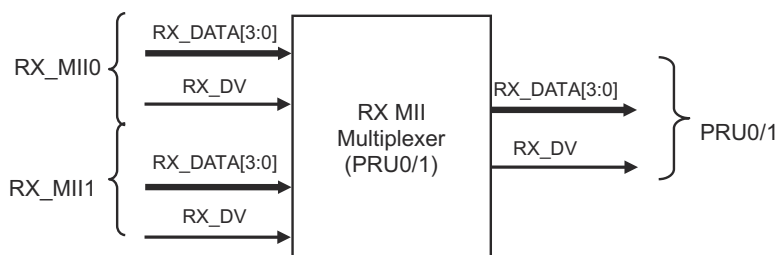

Figure 7-75. MII Receive Multiplexer

ADVANCE INFORMATION

There are two receive multiplexer instances to enable selection of RX MII path for each PRU. The select lines of the RX multiplexers are driven from the PRU-ICSS programmable registers (MII_RT_RXCFG0/1[3] RX_MUX_SELn, where n = 0 or 1).

7.2.10.2.6.3.2 Transmit Multiplexer

On the MII transmit ports, there is a multiplexer for each MII transmit port that enables selection of either the transmit data from the PRUs or from the RX MII interface of the other MII interface. Figure 7-76 shows a simple diagram of PRU transmit multiplexer.

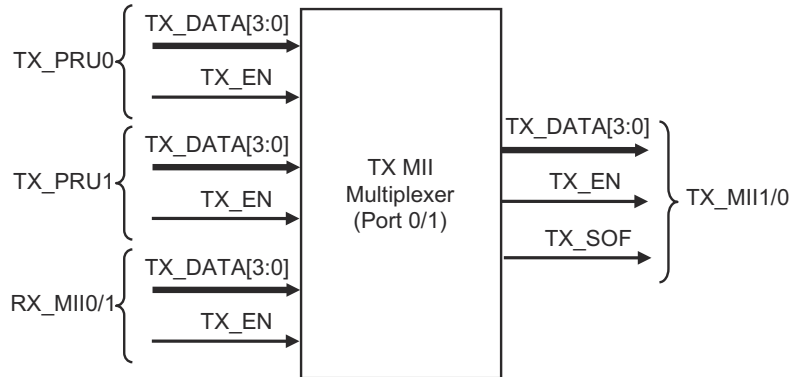

Figure 7-76. MII Transmit Multiplexer

The transmit multiplexers enable the PRU-ICSS to either operate in a bypass mode where the PRU is not involved in processing MII traffic or use of one of the PRU cores for transmitting data into the MII interface. There are two instances of the TX MII multiplexer and the select lines for each TX multiplexer are provided by the PRU-ICSS programmable registers (MII_RT_TXCFG0/1[8] TX_MUX_SELn, where n = 0 or 1). The select lines are common between register and FIFO interface. It is expected that the select lines will not change during the course of a frame so that can avoid data exchange error.

7.2.10.2.6.4 RX L2 Scratch Pad

When the RX L2 is disabled (MII_RT_RXCFG0/1[4] RX_L2_ENn = 0h, where n = 0 or 1), the RX L2 banks can be used as a generic scratch pad. In scratch pad mode, RX L2 Bank0 and RX L2 Bank1 operate like simple read/write memory mapped registers. All XFR size and start operations are supported. RX_RESET has no effect in this mode. This mode is shown in Figure 7-77.

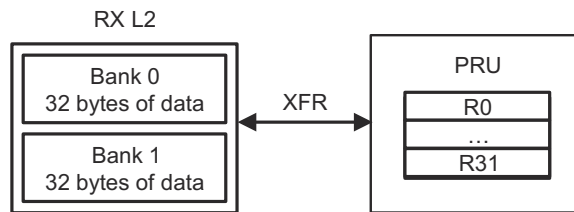

Figure 7-77. Scratch Pad Mode

7.2.11 PRU-ICSS MII MDIO Module

This section describes the PRU_ICSSM (where n = 0 or 1) integrated MII management interface (MII_MDIO module).

7.2.11.1 PRU-ICSS MII MDIO Overview

The following features are supported:

- Clause 22 and Clause 45.
- Up to 32 PHY addresses.
- Two user access registers to control and monitor up to two PHYs simultaneously.
- Slave interface for configuration and control (MII RT MDIO CFG)
- Each PHY can be individually enabled to be polled.
- The inter-poll gap between PHY polls can be changed.
- State Change Mode of operation to monitor up to 32 PHYs simultaneously.
- Manual control by software for GPIO operations.

The PRU-ICSS MII MDIO management I/F module implements the 802.3 serial management interface to interrogate and control two Ethernet PHYs simultaneously using a shared two-wire bus. Figure 7-78 shows a device with two MACs, each connected to an Ethernet PHY, being managed by the MII interface module using a shared bus.

The Figure 7-78 gives an overview of the MII MDIO management interface.

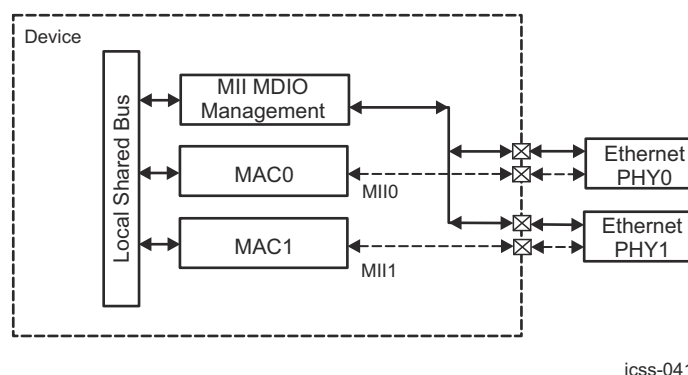

Figure 7-78. Device PRU-ICSS MII MDIO Management Interface Overview

7.2.11.2 PRU-ICSS MII MDIO Functional Description

The MII Management interface incorporates:

- **MDIO Registers** - The MDIO register block provides a VBUSP 3.0 compliant slave interface to the MDIO module. Host interaction with this module is facilitated through the registers in this block.
- **Control and Schedule** - The control and register logic in the MDIO module contain the state machine and scheduling logic which control the wire side operation.
- **MDIO Interface** - The MDIO interface block provides the serial interface to the MDIO interface.

The MDIO logic is fully synchronous to the PRU-ICSS local shared bus clock.

7.2.11.2.1 MDIO Clause 22 Frame Formats

The below Table 7-90 shows the read and write format of the Clause 22 Management interface frames.

Table 7-90. MDIO Clause 22 Frame Formats

Preamble	Start Delimiter	Operation Code	PHY Address	Register Address	Turnaround	Data
MDIO Clause 22 Read Frame Format						
FFFFFFFh	01	10	AAAAA	RRRRR	Z0	DDDD.DDDD.DDD D.DDDD
MDIO Clause 22 Write Frame Format						

Table 7-90. MDIO Clause 22 Frame Formats (continued)

Preamble	Start Delimiter	Operation Code	PHY Address	Register Address	Turnaround	Data
FFFFFFFFh	01	01	AAAAA	RRRRR	10	DDDD.DDDD.DDD D.DDDD

The default or idle state of the two wire serial interface is a logic one. All tri-state drivers should be disabled and the PHY's pull-up resistor will pull the MDIO line to a logic one. Prior to initiating any other transaction, the station management entity shall send a preamble sequence of 32 contiguous logic one bits on the MDIO line with 32 corresponding cycles on MDCLK to provide the PHY with a pattern that it can use to establish synchronization. A PHY shall observe a sequence of 32 contiguous logic one bits on MDIO with 32 corresponding MDCLK cycles before it responds to any other transaction.

Preamble

The start of a frame is indicated by a preamble, which consists of a sequence of 32 contiguous bits all of which are a "1". This sequence provides the Ethernet PHY a pattern to use to establish synchronization.

Start Delimiter

The preamble is followed by the start delimiter which is indicated by a "01" pattern. The pattern assures transitions from the default logic one state to zero and back to one.

Operation Code

The operation code for a read is "10", while the operation code for a write is a "01".

Ethernet PHY Address

The PHY address is 5 bits allowing 32 unique values. The first bit transmitted is the MSB of the PHY address.

Register Address

The Register address is 5 bits allowing 32 registers to be addressed within each PHY.

Turnaround

An idle bit time during which no device actively drives the MDIO signal shall be inserted between the *Register Address* field and the *Data* field of a read frame in order to avoid contention. During a read frame, the PHY shall drive a zero bit onto MDIO for the first bit time following the idle bit and preceding the Data field. During a write frame, this field shall consist of a one bit followed by a zero bit.

Data

The Data field is 16 bits. The first bit transmitted and received is the MSB of the data word.

7.2.11.2.1.1 PRU-ICSS MDIO Control and Interface Signals

The [Table 7-91](#) shows the PRU_ICSSM (where n = 0 to 2) MII MDIO signals and their availability at the device boundary.

Table 7-91. PRU-ICSS MII MDIO Control and Interface Signals

MDIO Control Signals			
Pin Name	Type	Available as device I/O	Function
MDIO_LINKINT[1:0]	O	N.A.	Serial interface link change interrupt. Indicates a change in the state of the PHY link.
MDIO_USERINT[1:0]	O	N.A.	Serial interface user command event complete interrupt.
MDIO Interface Signals			
Pin Name	Type	Available as device I/O	Function
MDIO_I	I	device bidirectional pr0_mdio_data , and pr1_mdio_mdclk pin in input mode	Serial data input
MDIO_O	O	device bidirectional pr0_mdio_data and pr1_mdio_mdclk pin in output mode	Serial data output

Table 7-91. PRU-ICSS MII MDIO Control and Interface Signals (continued)

MDIO Control Signals			
MDIO_OE_N	O	N.A.	Serial data output enable. Asserted "0" when data output is valid
MDCLK_O	O	device output - pr0_mdio_mdclk pr1_mdio_mdclk	Serial clock output
MLINK_I[1:0]	I	N.A.	Optional link status inputs from PHY. Each input is connected to a single PHY. Unused inputs are tied '0'.

7.2.11.2.2 MDIO Clause 45 Frame Formats

The below [Table 7-92](#) shows the address frame format. [Table 7-93](#) shows read, and write format of the supported Clause 45 frames. Post-increment accesses are not supported.

Table 7-92. MDIO Clause 45 Address Frame Formats

Pre-amble	Start Delimiter	Operation Code	PHY Address	MMD Number	Turnaround	Address
MDIO Clause 45 Address Frame Format						
FFFFFFFFh	00	00	AAAAA	RRRRR	10	AAAA.AAAA.AAA A.AAAA

Table 7-93. MDIO Clause 45 Frame Formats

Pre-amble	Start Delimiter	Operation Code	PHY Address	MMD Number	Turnaround	Data
MDIO Clause 45 Read Frame Format						
FFFFFFFFh	00	11	AAAAA	RRRRR	Z0	DDDD.DDDD.DD DD.DDDD
MDIO Clause 45 Write Frame Format						
FFFFFFFFh	00	01	AAAAA	RRRRR	10	DDDD.DDDD.DD DD.DDDD

The default or idle state of the two wire serial interface is a logic one. All tri-state drivers should be disabled and the PHY's pull-up resistor should pull the MDIO line to a logic one. Prior to initiating any other transaction, the station management entity shall send a preamble sequence of 32 contiguous logic one bits on the MDIO line with 32 corresponding cycles on MDCLK to provide the PHY with a pattern that it can use to establish synchronization. A PHY shall observe a sequence of 32 contiguous logic one bits on MDIO with 32 corresponding MDCLK cycles before it responds to any other transaction. The MDIO_USER_ADDR0_REG/ MDIO_USER_ADDR1_REG registers must be written before a read or write operation is performed to set the address used in the operation. Each read or write operation has a preceding address frame.

Preamble

The start of a frame is indicated by a preamble, which consists of a sequence of 32 contiguous bits all of which are a "1". This sequence provides the PHY a pattern to use to establish synchronization. The preamble is required in clause 45 operation.

Start Delimiter

The preamble is followed by the start delimiter which is indicated by a "00" pattern.

Operation Code

The operation code for address is "00". The operation code for a read is "11", while the operation code for a write is a "01".

Ethernet PHY Address

The PHY address is 5 bits allowing 32 unique values. The first bit transmitted is the MSB of the PHY address.

MMD Number

The MMD number is 5 bits allowing 32 unique values. The first bit transmitted is the MSB.

Turnaround

An idle bit time during which no device actively drives the MDIO signal shall be inserted between the **MMD Number** field and the **Data** field of a read frame in order to avoid contention. During a read frame, the PHY shall drive a zero bit onto MDIO for the first bit time following the idle bit and preceding the Data field. During a write frame, this field shall consist of a one bit followed by a zero bit.

Address

The address field is 16-bits on address operations. The first bit transmitted is the MSB of the address word. Each read/write operation initiated has an automatic address operation initiated first that uses the MDIO_USER_ADDR0_REG[15-0] USER_ADDR0 or MDIO_USER_ADDR1_REG[15-0] USER_ADDR1 register values as the 16-bit address.

Data

The Data field is 16 bits on read and write operations. The first bit transmitted and received is the MSB of the data word.

7.2.11.2.3 PRU-ICSS MII MDIO Interactions

The MDIO module will remain idle until enabled by setting the [30] ENABLE bit in the MDIO MDIO_CONTROL_REG register. The MDIO will then continuously poll the link status from within the Generic Status Register of all possible 32 PHY addresses in turn recording the results in the MDIO MDIO_LINK_REG register. Individual PHY's can be enabled or disabled for polling through the associated bit in the MDIO MDIO_POLL_EN_REG register. The MDIO MDIO_LINK_REG and MDIO_ALIVE_REG register bit values are updated on the poll of each PHY. In *Normal Mode*, the link status of two of the 32 possible PHY addresses can also be determined using the MLINK pin inputs. The bit [7] LINKSEL in the MDIO MDIO_USER_PHY_SEL_REG_0/1 register determines the status input that is used. A change in the link status of the two PHYs being monitored will set the appropriate bit ([1-0] LINKINTRAW) in the MDIO MDIO_LINK_INT_RAW_REG register and the MDIO_LINK_INT_MASKED_REG[1-0] LINKINTMASKED register, if enabled by the [6] LINKINT_ENABLE bit in the MDIO MDIO_USER_PHY_SEL_REG_0/1 register. In *State Change Mode*, a change in any PHY status will be indicated on the MDIO_LINK_INT_RAW_REG[0] LINKINTRAW interrupt if enabled.

The MDIO MDIO_ALIVE_REG register is updated by the MDIO module if the PHY acknowledged the read of the generic status register. In addition, any PHY register read transactions initiated by the host also cause the MDIO MDIO_ALIVE_REG register to be updated.

At any time, the host can define a transaction for the MDIO module to undertake using the [15-0] DATA, [20-16] PHYADR, [25-21] REGADR, and [30] WRITE fields in a MDIO_USER_ACCESS_REG_0/1 register. When the host sets the [31] GO bit in this register, the MDIO interface module will begin the transaction without any further intervention from the host. Upon completion, the MDIO will clear the [31] GO bit and set the [1-0] USERINTRAW bit field in the MDIO_USER_INT_RAW_REG register corresponding to the MDIO_USER_ACCESS_REG_0/1 register being used. The corresponding bit in the MDIO_USER_INT_MASKED_REG register may also be set depending on the mask setting in the MDIO_USER_INT_MASK_SET_REG and MDIO_USER_INT_MASK_CLEAR_REG registers. A round-robin arbitration scheme is used to schedule transactions which may be queued by the host in different MDIO_USER_ACCESS_REG_0/1 registers. The host should check the status of the [31] GO bit in the MDIO_USER_ACCESS_REG_0/1 register before initiating a new transaction to ensure that the previous transaction has completed. The host can use the [29] ACK bit in the MDIO_USER_ACCESS_REG_0/1 register to determine the status of a read transaction.

Software may use the MDIO module to set up the auto-negotiation parameters of each PHY attached to a MAC port, retrieve the negotiation results, and set up the MAC Control register in the corresponding MAC.

7.2.11.2.4 PRU-ICSS MII MDIO Interrupts

7.2.11.2.4.1 Normal Mode ([30]STATECHANGEMODE = 0h)

The MDIO will assert the MDIO_LINKINT signals if there is a change in the link state of the Ethernet PHY corresponding to the address in the [4-0] PHYADR_MON field of the MDIO MDIO_USER_PHY_SEL_REG_j (where j = 0 or 1) registers and the corresponding [6] LINKINT_ENABLE bit is set. The MDIO_LINKINT event is

also captured in the MDIO MDIO_LINK_INT_MASKED_REG register. MDIO_LINKINT[0] and MDIO_LINKINT[1] correspond to the MDIO MDIO_USER_PHY_SEL_REG_0 and MDIO_USER_PHY_SEL_REG_1 registers, respectively.

When the [31] GO bit in the MDIO_USER_ACCESS_REG_j (where j = 0 or 1) registers transitions from '1' to '0', indicating the completion of a user access, and the corresponding [1-0] USERINTMASKSET field in the

MDIO_USER_INT_MASK_SET_REG register is set, the MDIO_USERINT signal is asserted '1'. The MDIO_USERINT event is also captured in the MDIO_USER_INT_MASKED_REG register. MDIO_USERINT[0] and MDIO_USERINT[1] correspond to the MDIO_USER_ACCESS_REG_0 and MDIO_USER_ACCESS_REG_1 registers, respectively.

7.2.11.2.4.2 State Change Mode ([30]STATECHANGEMODE = 1h)

In *State Change Mode*, the MDIO will assert MDIO_LINKINT[0] when any bit in the MDIO MDIO_ALIVE_REG or MDIO MDIO_LINK_REG registers changes due to MDIO operations. The MDIO_LINKINT event is also captured in the MDIO MDIO_LINK_INT_MASKED_REG register. MDIO_LINKINT[1] output and the MDIO MDIO_USER_PHY_SEL_REG_j (where j = 0 or 1) registers are unused in *State Change Mode*.

7.2.11.2.5 Manual Mode

Manual Mode allows software to directly control the serial clock output (MDCLK_O), the serial data output enable (MDIO_OE_N), and the serial data output (MDIO_O). The serial data input can also be read (MDIO_I). This mode is enabled when the [31] MANUALMODE bit is set in the MDIO MDIO_POLL_REG register. *Manual Mode* is intended to be used by software for slow speed general purpose IO operations and not for MDIO PHY operations.

7.2.11.3 PRU-ICSS MII MDIO Receive/Transmit Frame Host Software Interface

To facilitate transmission and reception of serial management frames, the host has to perform the following operations:

- Configure the [20] PREAMBLE and [15-0] CLKDIV fields in the MDIO MDIO_CONTROL_REG register.
- Enable the MDIO module by setting the [30] ENABLE bit in the MDIO MDIO_CONTROL_REG register. If Byte access is being used, the [30] ENABLE bit should be written last.
- The MDIO MDIO_ALIVE_REG register can be read after a delay to determine which Ethernet PHYs responded.
- Set up the appropriate PHY addresses in the MDIO MDIO_USER_PHY_SEL_REG_j[4-0] PHYADR_MON bits.
- Set up the appropriate [6] LINKINT_ENABLE bit in the MDIO MDIO_USER_PHY_SEL_REG_j registers.
- Set up the appropriate [7] LINKSEL bits in the MDIO MDIO_USER_PHY_SEL_REG_j registers.
- Set up the appropriate [1-0] USERINTMASKEDSET field in the MDIO MDIO_USER_INT_MASK_SET_REG register.
- To write to an Ethernet PHY register the host should first check to ensure that the [31] GO bit in a MDIO MDIO_USER_ACCESS_REG_j registers is cleared. The [31] GO, [30] WRITE, [25-21] REGADR, [20-16] PHYADR and data fields in that MDIO MDIO_USER_ACCESS_REG_j registers can then be updated to the appropriate value. If byte access is being used, the [31] GO bit should be written last. The write operation to the PHY will be scheduled and completed by the module. Completion of the write operation can be determined by examining the [31] GO bit in the MDIO MDIO_USER_ACCESS_REG_j registers. It also results in a transition on the appropriate MDIO_INT signal and the corresponding bit in the MDIO MDIO_USER_INT_MASKED_REG register based on the setting of the MDIO MDIO_USER_INT_MASK_SET_REG register.
- To read from an Ethernet PHY register the host should first check to ensure that the [31] GO bit in a MDIO MDIO_USER_ACCESS_REG_j registers is cleared. The [31] GO, [25-21] REGADR, and [20-16] PHYADR fields in that MDIO MDIO_USER_ACCESS_REG_j registers can then be updated to the appropriate value. The read data value will be available in the [15-0] DATA field of the MDIO MDIO_USER_ACCESS_REG_j registers after the module completes the read operation on the serial bus. The completion of the read operation can be determined by examining the [31] GO and [29] ACK bits in the MDIO MDIO_USER_ACCESS_REG_j registers. It also results in a transition on the appropriate MDIO_INT

signal and the corresponding bit in the MDIO MDIO_USER_INT_MASKED_REG register based on the setting of the MDIO MDIO_USER_INT_MASK_SET_REG register.

- The module de-asserts the MDIO_USERINT signal when the host writes to the appropriate [1-0] USERINTMASKED bit field in the MDIO MDIO_USER_INT_MASKED_REG register or the [1-0] USERINTRAW bit field in the MDIO MDIO_USER_INT_RAW_REG register.
- The host can poll the MDIO MDIO_LINK_REG register periodically or use the MDIO_LINKINT signals to determine the state of the serial interface to a particular Ethernet PHY.
- The module de-asserts the MDIO_LINKINT when the host writes to the appropriate [1-0] LINKINTRAW bit field in the MDIO MDIO_LINK_INT_RAW_REG register or the [1-0] LINKINTMASKED bit field in the MDIO MDIO_LINK_INT_MASKED_REG register.

Table 7-94. Summary of the PRU-ICSS MII MDIO Functional Registers

Address Offset	Register Mnemonic	Register Name	Register Purpose
00h	MDIOVer	MDIO_MDIO_VERSION_REG	Module version register
04h	MDIOControl	MDIO_CONTROL_REG	Module control register
08h	MDIOAlive	MDIO_ALIVE_REG	Ethernet PHY acknowledge status register
0Ch	MDIOLink	MDIO_LINK_REG	Ethernet PHY link status register
10h	MDIOLinkIntRaw	MDIO_LINK_INT_RAW_REG	Link status change interrupt register (raw value)
14h	MDIOLinkIntMasked	MDIO_LINK_INT_MASKED_REG	Link status change interrupt register (masked value)
18h	MDIOLinkIntMaskSet	MDIO_LINK_INT_MASK_SET_REG	Link status change interrupt mask set register
1Ch	MDIOLinkIntMaskClr	MDIO_LINK_INT_MASK_CLEAR_REG	Link status change interrupt mask clear register
20h	MDIOUserIntRaw	MDIO_USER_INT_RAW_REG	User command complete interrupt register (raw value)
24h	MDIOUserIntMasked	MDIO_USER_INT_MASKED_REG	User command complete interrupt register (masked value)
28h	MDIOUserIntMaskSet	MDIO_USER_INT_MASK_SET_REG	User interrupt mask set register
2Ch	MDIOUserIntMaskClr	MDIO_USER_INT_MASK_CLEAR_REG	User interrupt mask clear register
30h	MDIOManual_IF	MDIO_MANUAL_IF_REG	Manual interface register
34h	MDIOPoll_IPG	MDIO_POLL_REG	Poll and IPG register
38h	MDIOPoll_En	MDIO_POLL_EN_REG	Poll Enable register
3Ch	MDIOClause	MDIO_CLAUS45_REG	Clause 22 or 45 enable register
40h	MDIOUser_Addr0	MDIO_USER_ADDR0_REG	User Address register 0
44h	MDIOUser_Addr1	MDIO_USER_ADDR1_REG	User Address register 1
48h – 7Ch	Reserved	-	Reserved
80h	MDIOUserAccess0	MDIO_USER_ACCESS_REG_0	User access register 0
84h	MDIOUserPhySel0	MDIO_USER_PHY_SEL_REG_0	User PHY select register 0

Table 7-94. Summary of the PRU-ICSS MII MDIO Functional Registers (continued)

Address Offset	Register Mnemonic	Register Name	Register Purpose
88h	MDIOUserAccess1	MDIO_USER_ACCESS_REG_1	User access register 1
8Ch	MDIOUserPhySel1	MDIO_USER_PHY_SEL_REG_1	User PHY select register 1
90h – FFh	Reserved	-	Reserved

7.2.12 PRU-ICSS IEP

This section describes the Industrial Ethernet Peripheral (IEP) Module which is part of the PRU-ICSS.

7.2.12.1 PRU-ICSS IEP Overview

The Industrial Ethernet Peripheral (IEP) performs hardware work required for Industrial Ethernet functions. The IEP module features an industrial ethernet timer with 16 compare events, industrial ethernet sync generator and latch capture, industrial ethernet watchdog timer, and a digital I/O port (EDGIO).

7.2.12.2 PRU-ICSS IEP Functional Description

This section provides the functional description of the IEP component. The PRU-ICSS module implements one Industrial Ethernet Peripheral (IE0). The IEP functional block diagram is shown in [Figure 7-79](#).

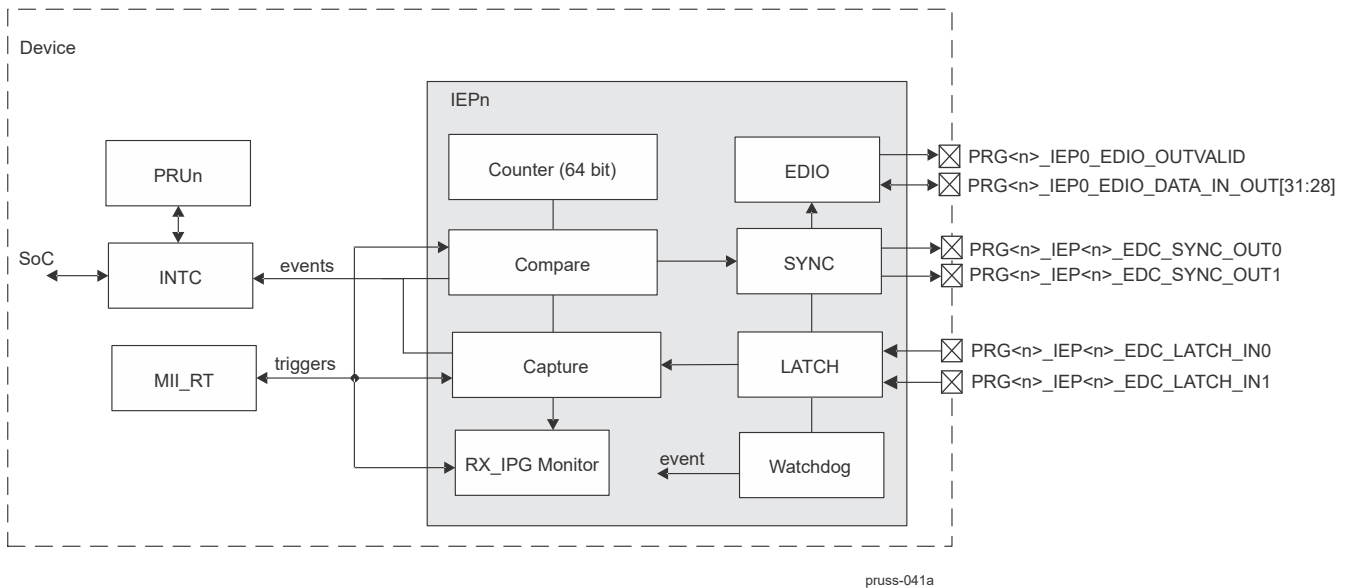

n = 0

Figure 7-79. IEP Functional Block Diagram

7.2.12.2.1 PRU-ICSS IEP Clock Generation

The IEP has a selectable module input clock (ICSSM_IEP_CLK, see also *PRU-ICSS in Module Integration*). The clock source is selected by the state of the CTRLMMR_ICSSM_CLKSEL[19-16] IEP_CLKSEL bit within the CTRL_MMR0 register space. Two clock sources are supported for the IEP input clock:

- ICSSM_IEP_CLK (where n = 0 or 1): The source clock for IEP module can be selected through IEP Clock Multiplexer (see also *PRU-ICSS in Module Integration*). The default functional source clock for IEP is MAIN_PLL3_HSDIV1_CLKOUT, derived from PLL3 HSDIV1. The IEP functional clock (ICSSM_IEP_CLK) runs at 200 or 250 MHz.
- ICSSM_ICLK (where n = 0 or 1): The PRU-ICSS interface clock is derived as divided version of the device PLLCTRL output clock (SYSCLK0/2).

Switching from ICSSM_IEP_CLK to ICSSM_ICLK is done by writing 1h to the ICSSM_IEPCLK_REG/ICSSM0_IEPCLK_REG[0] IEP_OCP_CLK_EN bit. This is a one time configuration step before enabling the IEP function. Switching back from ICSSM_ICLK to ICSSM_IEP_CLK is only supported through a hardware reset of the PRU-ICSS.

CAUTION

When software enables the clock (at PRU-ICSS level) to the IEP module clock input via setting bit ICSSM_IEPCLK_REG/ICSSM0_IEPCLK_REG[0] IEP_OCP_CLK_EN to 1h in the PRUSS_CFG space, there must be NO in-flight transactions to the IEP block.

CAUTION

Switching from ICSSM_IEP_CLK (the IEP specific functional clock source) to the ICSSM_CORE_CLK source is supported ONLY in software. Switching back from ICSSM_CORE_CLK to ICSSM_IEP_CLK is ONLY supported via assertion of a hardware reset to the PRU-ICSS.

7.2.12.2.2 PRU-ICSS IEP Timer

The IEP timer is a simple 64-bit timer. This timer is intended for use by industrial ethernet functions but can also be leveraged as a generic timer in other applications.

7.2.12.2.2.1 PRU-ICSS IEP Timer Features

The IEP timer supports the following features:

- One controller 64-bit count-up counter with an overflow status bit.
 - Runs on ICSS_IEP_CLK or ICSS_ICLK clock.
 - Write 1h to clear status.
 - Supports a programmable increment value from 1 to 16 (default 5).
 - An optional compensation method allows the increment value to apply compensation increment value from 1 to 16 count up to 2²⁴ ICSS_IEP_CLK events with additional slow compensation mode.
- 10× 64-bit capture registers:
 - 8 capture inputs, with optional synchronous or asynchronous mode:
 - 6× rise capture registers: ICSS_IEP_CAPRi_REG0/ IEP_CAPRi_REG1 (where i=0 to 5)
 - 2× rise and fall capture registers: IEP_CAPR6_REG0/ IEP_CAPR6_REG1 and IEP_CAPR7_REG0/ IEP_CAPR7_REG1, each combined with a fall capture - IEP_CAPF6_REG0/ IEP_CAPF6_REG1 and IEP_CAPF7_REG0/ IEP_CAPF7_REG1, respectively
 - One global event (any capture event) output for interrupt
- 16× 64-bit compare registers: IEP_CMPj_REG0/ IEP_CMPj_REG1 (where j = 0 to 15) and IEP_CMP_STATUS_REG[15-0] CMP_STATUS
 - 16 status bits, write 1h to clear
 - 16 individual event outputs
 - One global event output for interrupt generation triggered by any compare event
- 32 outputs, one high-level and one high-pulse for each compare hit event
- IEP_CMP_CFG_REG[0] CMP0_RST_CNT_EN, if enabled, resets the controller counter on the next ICSS_IEP_CLK/ ICSS_ICLK cycle
- Controller counter reset-state is programmable
- Optional 32-bit shadow mode of operation, which can be configured through IEP_CMP_CFG_REG[17] SHADOW_EN bit

7.2.12.2.3 32-Bit Shadow Mode

The IEP module can be configured in 32-bit shadow mode when IEP_CMP_CFG_REG[17] SHADOW_EN bit is set to 1h (default value is 0h, e.g. 64-bit mode of operation is enabled). In this mode, the controller counter will be in 32-bit mode of operation. This enables the shadow copy functionality of the compare registers.

Rules of operation:

1. Switching the state of the controller counter from 32-bit Shadow mode to 64-bit mode of operation, the counter should be disabled and bit IEP_CMP_CFG_REG[17] SHADOW_EN should be cleared to 0h (default value).

- A new compare update (IEP_CMP_CFG_REG[16-1] CMP_EN = 1h - enables CMP[0:15] event, where [0]CMP_EN maps to CMP0) should be set 4 cycle counts before the next rollover or reset of the counter and to insure the correct shadow copy to active update is correct.

Sequence of operation:

- Disable counter through IEP_GLOBAL_CFG_REG[0] CNT_ENABLE = 0h (default value).
- Clear controller counter through IEP_CMP_CFG_REG[17] SHADOW_EN = 0h (64-bit mode of operation)
- Enable 32-bit Shadow mode through IEP_CMP_CFG_REG[17] SHADOW_EN bit (value: 1h)
- Program IEP_CMPm_REGn (where m = 0 to 15 and n = 0 to 1); use the upper 32-bits (IEP_CMP0_REG1[31-0] CMP0_1) of the 64-bit CMP
 - The lower 32-bits are the active compare value (IEP_CMPm_REG0[31-0] CMPm_0, where m = 0 to 15), software can only read this bits
 - The upper 32-bits are the shadow copy (IEP_CMPm_REG1[31-0] CMPm_1, where m = 0 to 15), software can write and read this bits
- Enable counter through IEP_GLOBAL_CFG_REG[0] CNT_ENABLE = 1h

After the counter is enabled, then software can load a new set of CMP[0:15] without affecting the current active values of (IEP_CMPm_REG0[31-0] CMPm_0, where m = 0 to 15). Only when the counter is reset to 32-bit Shadow mode (IEP_CMP_CFG_REG[17] SHADOW_EN = 1h), it will load the shadow copy of IEP_CMPm_REG1[31-0] CMPm_1 into local copy.

Shadow compare value (IEP_CMPm_REG1[31-0] CMPm_1) is loaded into active register IEP_CMPm_REG0[31-0] CMPm_0 when the controller counter is configured in 32-bit Shadow mode. If IEP_CMP_CFG_REG[0] CMP0_RST_CNT_EN bit is enabled (value 1h) to reset the counter, the next reset event will be defined by the last CMP0 update.

7.2.12.2.4 PRU-ICSS IEP Timer Basic Programming Sequence

Follow these basic steps to configure the IEP Timer.

Counter maintains/function:

- Once enabled, the counter will count every ICSSM_IEP_CLK cycle, default rate of 200 MHz.
- It is a free running counter with a sticky over flag status bit.
- The counter over flow flag (IEP_GLOBAL_STATUS_REG[0] CNT_OVF) will get set when the counter switches/rollover from 0xFFFF_FFFF to 0x0000_0000.
- The counter will continue to count up. The software will need to read/clear the counter over flow flag and increment the MSB in software variable.

Compare function:

- Initialize timer to known state (default values)
 - Disable counter (IEP_GLOBAL_CFG_REG[0] CNT_ENABLE = 0)
 - Reset Count Register (IEP_COUNT_REG0, IEP_COUNT_REG1) by writing FFFFFFFFh to clear
 - Clear overflow status register (IEP_GLOBAL_STATUS_REG[0] CNT_OVF = 1)
 - Clear compare status (IEP_CMP_STATUS_REG[15-0] CMP_STATUS) by writing FFFFFFFFh to clear
- Set compare values IEP_CMPj_REG0, IEP_CMPj_REG1 (where j = 0 to 15)
- Enable compare events (IEP_CMP_CFG_REG[16-1] CMP_EN = 1)
- Set increment value (IEP_GLOBAL_CFG_REG[7-4] DEFAULT_INC)
- Set compensation value (IEP_COMPEN_REG[22-0] COMPEN_CNT)
- Enable counter (IEP_GLOBAL_CFG_REG[0] CNT_ENABLE = 1)

Capture function:

- Update/Enable the counter if required
- Program the enable the desired capture event
- Wait for global capture event
- Read/Clear the capture status to determine which capture event occurred
- Read the capture count

7.2.12.2.5 Industrial Ethernet Mapping

Some of the capture inputs and compare registers are mapped to specific industrial Ethernet functions in hardware, shown in [Table 7-95](#). All capture inputs are mapped to industrial Ethernet functions, and these inputs are not available for any other application. The CMP1 and CMP2 compare registers also function as the start time triggers for SYNC0 and SYNC1, respectively.

Table 7-95. IEP Timer Mode Mapping

Capture Input	IEP Line/Function
IEP_CAPR0_REG0/ IEP_CAPR0_REG1, rise only	If EXT_CAP_EN[0] = 0h (Internal source is selected)/ PRU0_RX_SOF If EXT_CAP_EN[0] = 1h (External source is selected)/ ICSS_IEP_CAP_INTR_REQ0
IEP_CAPR1_REG0/ IEP_CAPR1_REG1, rise only	If EXT_CAP_EN[1] = 0h (Internal source is selected)/ PRU0_RX_SFD If EXT_CAP_EN[1] = 1h (External source is selected)/ ICSS_IEP0_CAP_INTR_REQ1
IEP_CAPR2_REG0/ IEP_CAPR2_REG1, rise only	If EXT_CAP_EN[2] = 0h (Internal source is selected)/ PRU1_RX_SOF If EXT_CAP_EN[2] = 1h (External source is selected)/ ICSS_IEP_CAP_INTR_REQ2
IEP_CAPR3_REG0/ IEP_CAPR3_REG1, rise only	If EXT_CAP_EN[3] = 0h (Internal source is selected)/ PRU1_RX_SFD If EXT_CAP_EN[3] = 1h (External source is selected)/ ICSS_IEP_CAP_INTR_REQ3
IEP_CAPR4_REG0/ IEP_CAPR4_REG1, rise only	If EXT_CAP_EN[4] = 0h (Internal source is selected)/ PORT0_TX_SOF; For MII mode uses loopback for lower jitter 40ns versus 4ns. If EXT_CAP_EN[4] = 1h (External source is selected)/ ICSS_IEP_CAP_INTR_REQ4
IEP_CAPR5_REG0/ IEP_CAPR5_REG1, rise only	If EXT_CAP_EN[5] = 0h (Internal source is selected)/ PORT1_TX_SOF For MII mode uses loopback for lower jitter 40ns versus 4ns. If EXT_CAP_EN[5] = 1h (External source is selected)/ ICSS_IEP_CAP_INTR_REQ5
IEP_CAPR6_REG0/ IEP_CAPR6_REG1 - rise and IEP_CAPF6_REG0/ IEP_CAPF6_REG1 - fall	PR_IEP_EDC_LATCH_IN0 (IO inputs at SoC level)
IEP_CAPR7_REG0/ IEP_CAPR7_REG1 - rise and IEP_CAPF7_REG0/ IEP_CAPF7_REG1 - fall	PR_IEP_EDC_LATCH_IN1 (IO inputs at SoC level)
IEP_CMP1_REG0/ IEP_CMP1_REG1	For SYNC0 trigger of start time
IEP_CMP2_REG0/ IEP_CMP2_REG1	For SYNC1 trigger of start time; only valid in the SYNC2 independent mode
IEP_CMP3_REG0/ IEP_CMP3_REG1	For MII TX0 start trigger, if MII register MII_RT_TXCFG0/1[2] TX_EN_MODE _n is enabled (where n = 0 or 1).
IEP_CMP4_REG0/ IEP_CMP4_REG1	For MII TX1 start trigger, if MII register MII_RT_TXCFG0/1[2] TX_EN_MODE _n is enabled (where n = 0 or 1).

7.2.12.2.6 PRU-ICSS IEP Sync0/Sync1 Module

The industrial ethernet sync block supports the generation of two synchronization signals: SYNC0 and SYNC1. SYNC0 and SYNC1 can be directly mapped to output signals (pr<k>_iep<n>_edc_sync_out0 and pr<k>_iep<n>_edc_sync_out1) for external devices to use. They can also be used for internal synchronization within the PRU-ICSS. These signals are also mapped as system events and can therefore be mapped to the Arm core's Host interrupts.

7.2.12.2.6.1 PRU-ICSS IEP Sync0/Sync1 Features

The industrial ethernet sync block supports the following features:

- Two synchronize generation signals (SYNC0, SYNC1)
 - Activation time synchronized with IEP Timer

- IEP_CMP1_REG0/ IEP_CMP1_REG1 triggers SYNC0 activation time
- IEP_CMP2_REG0/ IEP_CMP2_REG1 triggers SYNC1 activation time (only valid in the SYNC2 independent mode)
 - Pulse width defined by registers or acknowledge mode (remain asserted until software acknowledged)
 - Cyclic or single-shot operation
 - Option to enable or disable sync generation
- Programmable number of clock cycles between the start of SYNC0 to the start of SYNC1

7.2.12.2.6.2 PRU-ICSS IEP Sync0/Sync1 Generation Modes

There are four modes of operation for the sync signals: cyclic mode, single shot mode, cyclic with acknowledge mode, and single shot with acknowledge mode. Figure 7-80 shows examples of these modes. The start time is set by the IEP_SYNC_START_REG[31-0] SYNC_START bit field. The cycle time is configured by the IEP_SYNC0_PERIOD_REG[31-0] SYNC0_PERIOD bit field. The pulse length is defined by IEP_SYNC_PWIDTH_REG[31-0] SYNC_HPW bit field.

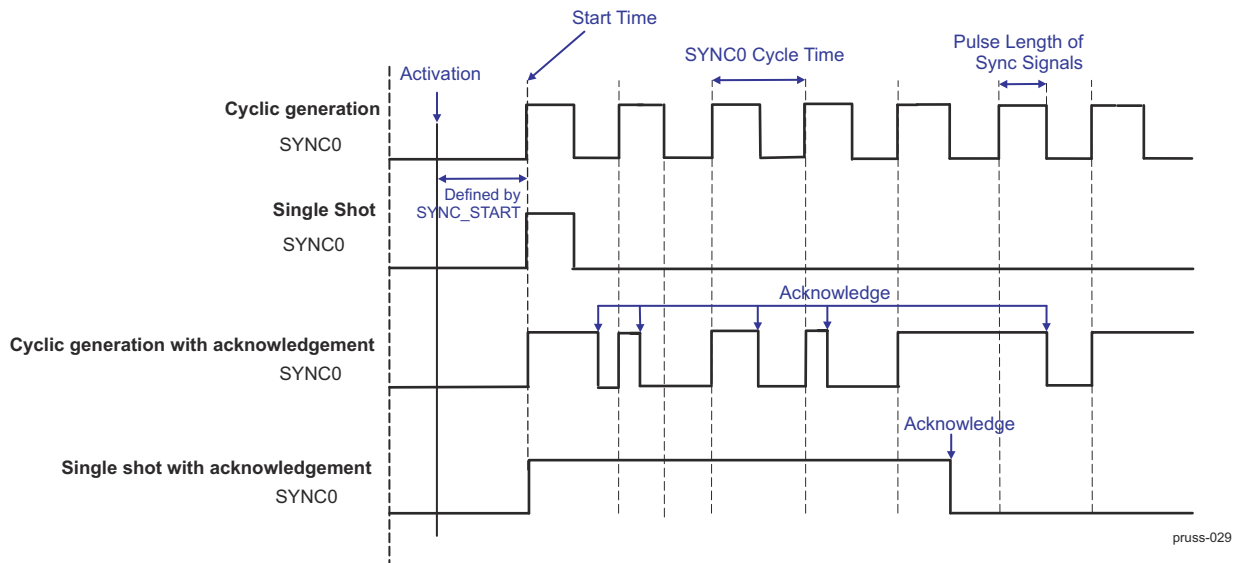
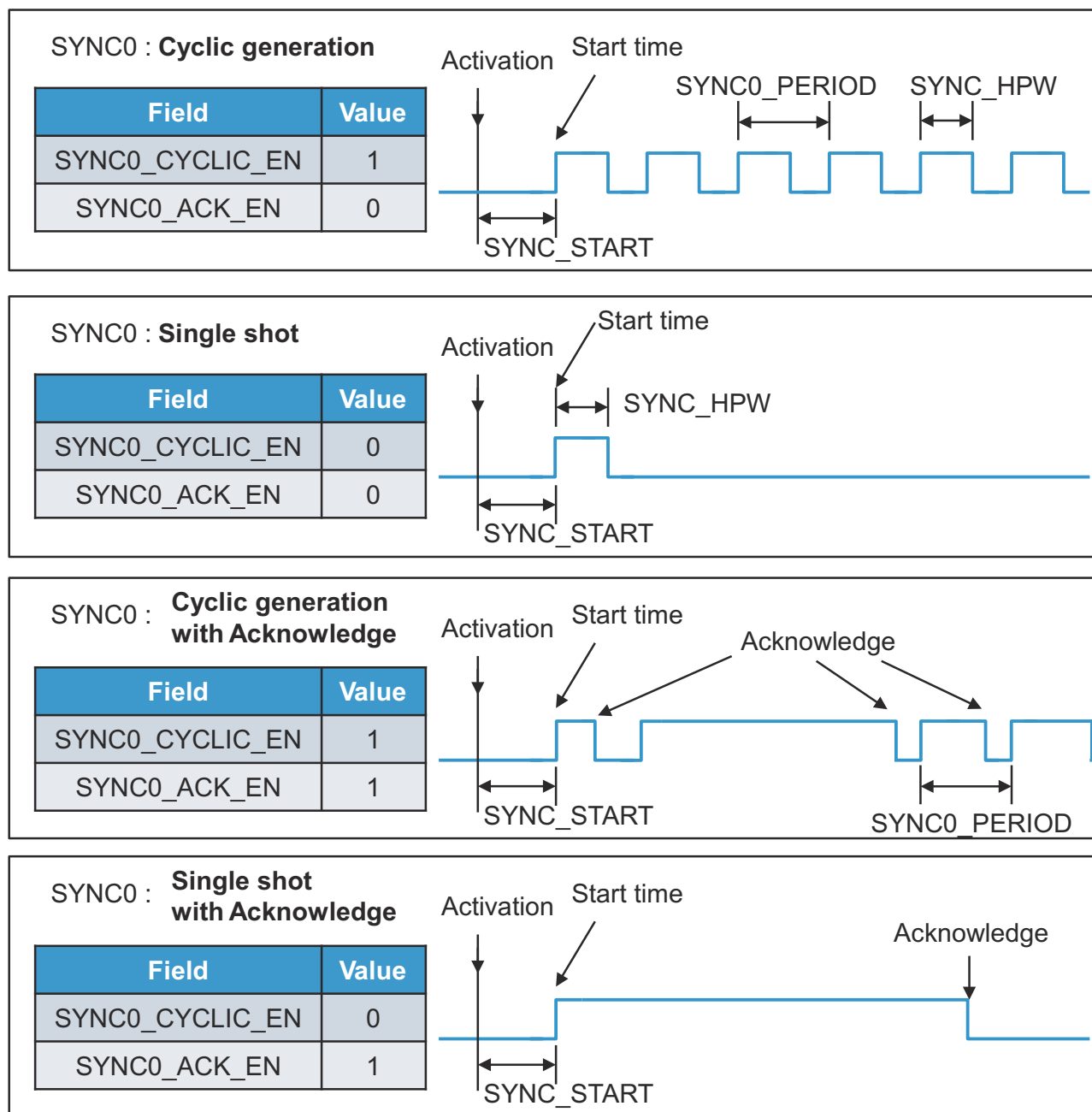

Figure 7-80. PRU-ICSS IEP SYNC0 Signal Generation Modes

In SYNC1 dependent mode (IEP_SYNC_CTRL_REG[8] SYNC1_IND_EN = 0h), SYNC1 depends on SYNC0 and the start time of the SYNC1 can be defined by the IEP_SYNC1_DELAY_REG register. Figure 7-81 shows different examples when changing the value in the IEP_SYNC1_DELAY_REG register. Note: If the SYNC1 delay time is 0, SYNC1 reflects SYNC0. Cyclic generation cannot be used for network time synchronized applications because only the CMP1/CMP2 hit occurs in the compensated time domain.



pruss-031

Figure 7-81. Examples of the Dependent Mode of SYNC1

7.2.12.2.7 PRU-ICSS IEP WatchDog

In industrial ethernet applications, the watchdog timer (WD) is used to monitor process data communication and to turn off the outputs of the digital input/output (DIGIO) functional block after a set time. The WD will thereby protect the system from errors or faults by timeout or expiration. The expiration is used to initiate corrective action in order to keep the system in a safe state and restore normal operation based on configuration. Therefore, if the system is stable, the watchdog timer should be regularly reset or cleared to avoid timeout or expiration.

The IEP watchdog timer supports the following features:

- One 16-bit pre-divider for generating a WD clock (default 100µs) based on ICSSM_IEP_CLK input
- Two 16-bit Watchdog Timers:

- PDI_WD for Sync Managers WD, used in conjunction with digital input/output (DIGIO)
- PD_WD for data link layer user WD, used in conjunction with data link layer or application layer interface actions

Note

For more details on the PRU-ICSS Industrial Ethernet Watchdog timer, refer also to the Watchdog timer register descriptions covered in the , *PRU-ICSS IEP Registers* .

7.2.12.2.8 PRU-ICSS IEP DIGIO

The IEP digital I/O (DIGIO) block provides dedicated I/Os for industrial ethernet protocols. The digital inputs can be sampled when specific events occur or continuously as a raw input. Likewise, driving the digital outputs can be triggered by specific events or controlled by software. The timing, delay cycle clocks, data sources, and data valid of the digital input and outputs are controlled by the IEP_DIGIO_CTRL_REG and IEP_DIGIO_EXP_REG registers. Additionally, the IEP DIGIO block can be used as generic I/Os in other applications.

7.2.12.2.8.1 PRU-ICSS IEP DIGIO Features

The IEP digital I/O supports the following features:

- Digital data output:
 - 4 channels (PRG<k>_IEP0_EDIO_DATA_IN_OUT[31:28])
 - Five event options for driving output data output:
 - End of frame event (PRU0/1_RX_EOF)
 - SYNC0 events
 - SYNC1 events
 - Watchdog trigger
 - Software enable
- Digital data out enable (optional tri-state control)
- Digital data input:
 - 4 channels (PRG<k>_IEP0_EDIO_DATA_IN_OUT[31:28])
 - IEP_DIGIO_DATA_IN_RAW_REG supports direct sampling of PRG<k>_IEP0_EDIO_DATA_IN_OUT[31:28]
 - IEP_DIGIO_DATA_IN_REG supports four event options to trigger sampling of PRG<k>_IEP0_EDIO_DATA_IN_OUT[31:28]:
 - Start of frame event in start of frame (SOF) mode
 - pr<k>_iepn_edc_latch_in<0/1> event
 - SYNC0 events: pr<k>_iepn_edc_sync_out0
 - SYNC1 events: pr<k>_iepn_edc_sync_out1

The industrial digital I/Os supported by the PRU-ICSS IEP peripheral are described in the:

Table 7-96. PRU-ICSS IEP Digital IOs

Direction	Port	Mapped to Device I/Os	Notes
output	PRG<k>_IEP0_EDIO_DATA_IN_OUT[0:31]	PRG0_IEP0_EDIO_DATA_IN_OUT[31:28] PRG1_IEP0_EDIO_DATA_IN_OUT[31:28]	Only PRG<k>_IEP0_EDIO_DATA_IN_OUT[31:28] are exported to device pins as a bidirectional.
output	PRG<k>_EDIO_DATA_OUT_EN[0:31]	No	Optional tri-state control for DATA_OUT
output	PRG<k>_IEP0_EDIO_OUTVALID	PRG0_IEP0_EDIO_OUTVALID PRG1_IEP0_EDIO_OUTVALID	Will pulse even same data
output	PRG<k>_EDIO_SOF	No	PRU<0/1>_RX_SOF defined by IEP_DIGIO_EXP_REG[12] SOF_SEL
input	PRG<k>_EDIO_OE_EXT	No	
output	PRG<k>_EDIO_WD_TRIG	No	Just export of IEP_WD_STATUS_REG[0] PD_WD_STAT

Table 7-96. PRU-ICSS IEP Digital IOs (continued)

Direction	Port	Mapped to Device I/Os	Notes
output	PRG<k>_EDIO_DATA_ENA	No	Reserved. Driven low.
input	PRG<k>_IEP<n>_EDC_LATCH_IN0	PRG0_IEP<n>_EDC_LATCH_IN0 PRG1_IEP<n>_EDC_LATCH_IN0	
input	PRG<k>_IEP<n>_EDC_LATCH_IN1	PRG0_IEP<n>_EDC_LATCH_IN1 PRG1_IEP<n>_EDC_LATCH_IN1	
output	PRG<k>_IEP<n>_EDC_SYNC_OUT0	PRG0_IEP<n>_EDC_SYNC_OUT0 PRG1_IEP<n>_EDC_SYNC_OUT0	
output	PRG<k>_IEP<n>_EDC_SYNC_OUT1	PRG0_IEP<n>_EDC_SYNC_OUT1 PRG1_IEP<n>_EDC_SYNC_OUT1	

7.2.12.2.8.2 PRU-ICSS IEP DIGIO Block Diagrams

Figure 7-82 shows the signals and registers for capturing the DIGIO data in. Note that bit field [5-4]IN_MODE in the IEP_DIGIO_CTRL_REG register must be set to 1h for data to be latched on the external PRG<k>_IEP<n>_EDC_LATCH_IN0 signal. In PRU0/1_RX_SOF mode, the delay time of capturing PRG<k>_IEP0_EDIO_DATA_IN_OUT[31:28] is programmable through the [11-8]SOF_DLY bit of the IEP_DIGIO_EXP_REG register.

ADVANCE INFORMATION

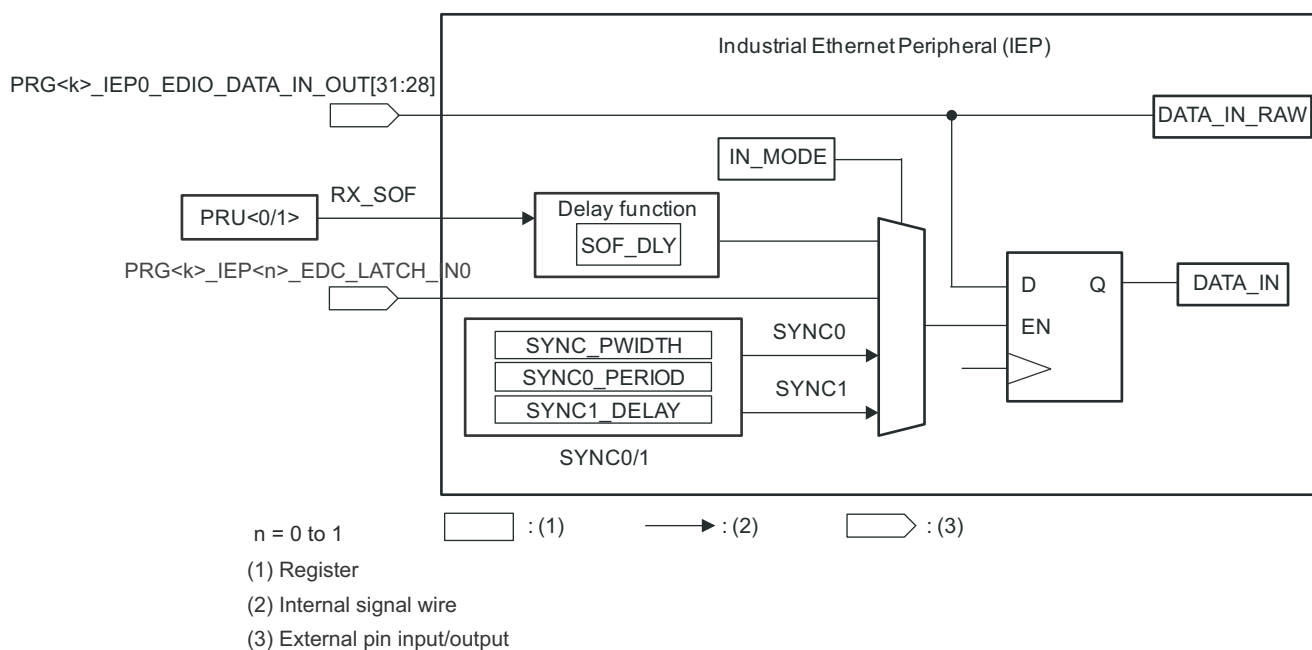

Figure 7-82. IEP DIGIO Data In

Figure 7-83 shows the signals and registers for driving the DIGIO data out.

The PRG<k>_IEP0_EDIO_DATA_IN_OUT[31:28] is immediately forced to zero when IEP_DIGIO_CTRL_REG[1] OUTVALID_MODE = 1h, pr1_edio_oe_ext = 1h, and pd_wd_exp = 1h, or the next update hardware post pd_wd_exp. Delay assertion of PRG<k>_IEP0_EDIO_OUTVALID from PRG<k>_IEP0_EDIO_DATA_IN_OUT[31:28] update events are controlled by software through IEP_DIGIO_EXP_REG[2] SW_OUTVALID.

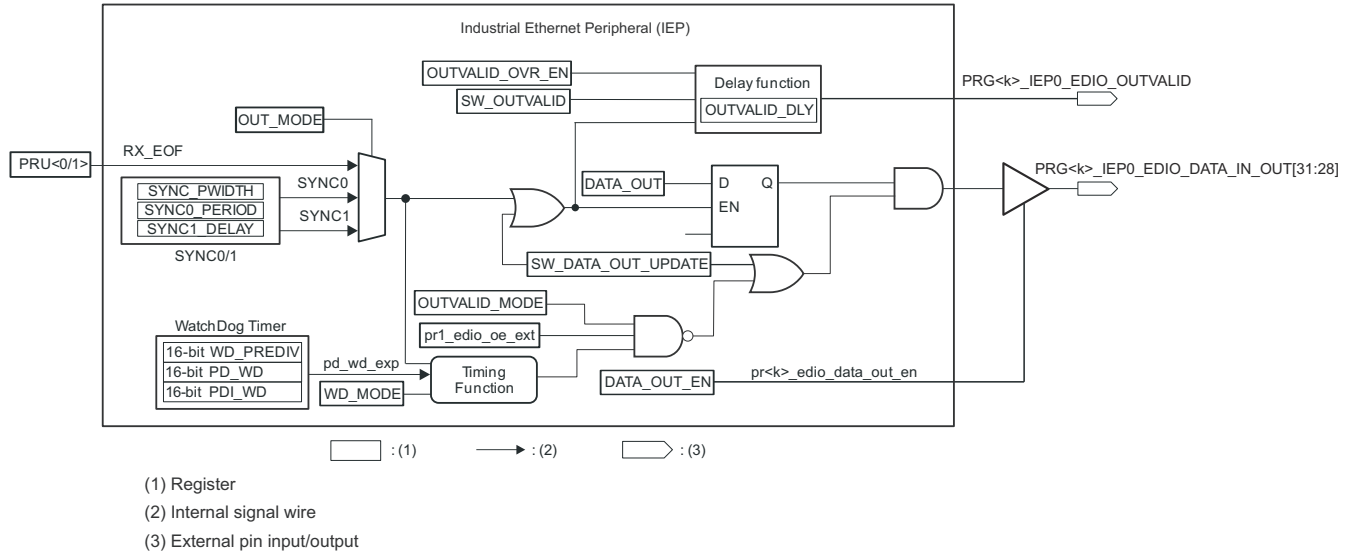

Figure 7-83. IEP DIGIO Data Out

7.2.12.2.8.3 PRU-ICSS IEP Basic Programming Model

Follow these steps to configure and read the DIGIO Data Input:

1. Read IEP_DIGIO_DATA_IN_RAW_REG for raw input data

or

1. Enable sampling of PRG<k>_IEP0_EDIO_DATA_IN_OUT[31:28] by setting IEP_DIGIO_CTRL_REG[5-4] IN_MODE = 1h.
2. Read IEP_DIGIO_DATA_IN_REG for data sampled upon PRG<k>_IEP<n>_EDC_LATCH_IN0 posedge

Follow these steps to configure and write to the DIGIO Data Output:

1. Pre-configure DIGIO by setting IEP_DIGIO_EXP_REG[1] OUTVALID_OVR_EN and [0] SW_DATA_OUT_UP
2. Write to IEP_DIGIO_DATA_OUT_REG to configure output data.
3. To HiZ output, set corresponding IEP_DIGIO_DATA_OUT_EN_REG[31-0] DATA_OUT_EN bits to 1h (clear to 0h to drive value stored in IEP_DIGIO_DATA_OUT_REG).

7.3 Hardware Security Module (HSM)

This chapter describes the Hardware Security Module (HSM) in the device.

The HSM module is responsible for booting up of the device, enabling the main R5FSS core, defining/controlling overall security of the device based on boot options provided. It also has a DTHE (Data Transform and Hashing Engine) which is a wrapper around crypto IP with some additional capability including CRC and Checksum.

Note

The TRM provides a high-level overview of the HSM. Please contact your TI representative for additional details.

7.4 Real-time Control Subsystem (CONTROLSS)

This chapter describes the features and functions of the device Real-time Control Subsystem (CONTROLSS).

Note

This content is currently **under-construction** and subject to change prior to official device release.

7.4.1 Real-time Control Subsystem (CONTROLSS) Overview

The AM263x Real-time Control subsystem or CONTROLSS enables closed loop control systems with flexible interconnection between data acquisition, actuator modules, and other control signal resources.

A real-time control system is typically composed of four main elements:

- **Sensing:** or feedback acquisition. The application needs to measure several key parameters (voltage, current, motor speed, temperature) in an accurate manner and at a very precise moment in time.
- **Processing:** Use the sensing information to apply control algorithms to the incoming data and calculate the next output command.
- **Control:** The command is applied to the system, typically via a PWM unit driving the power electronics system, for example, the motor turns faster, the current to the solar installed system is reduced, the car is accelerating.
- **Interface:** The ability of the device to communicate to other external components. While not necessarily involved in the control of the system, communications to other system components also has to co-exist with the main control loop.

The CONTROLSS consists of various control peripherals to enable full integration the **Sensing** and **Control** functionality of the device within real-time applications. The components of the subsystem are described in the following sections.

Note

In regards to various tables, diagrams, and descriptions throughout this chapter in the AM263x device TRM.

References to the *C28x* component/functional block (also referred to as *CPU* or *processor core*) is synonymous with the AM263x R5FSS core.

References to to the *CLA* component/functional block are not applicable to this device and should be ignored.

Note

The content in this chapter is under-construction.

7.4.2 Analog-to-Digital Converter (ADC)

The analog-to-digital converter (ADC) module described in this chapter is a .

7.4.2.1 Introduction.....	403
7.4.2.2 ADC Integration.....	405
7.4.2.3 ADC Configurability.....	407
7.4.2.4 SOC Principle of Operation.....	415
7.4.2.5 SOC Configuration Examples.....	420
7.4.2.6 ADC Conversion Priority.....	422
7.4.2.7 Burst Mode.....	425
7.4.2.8 EOC and Interrupt Operation.....	427
7.4.2.9 Post-Processing Blocks.....	429
7.4.2.10 Power-Up Sequence.....	432
7.4.2.11 ADC Calibration.....	432
7.4.2.12 ADC Timings.....	434
7.4.2.13 Additional Information.....	437

7.4.2.1 Introduction

The ADC module is a successive approximation (SAR) style ADC. The ADC is composed of a core and a wrapper. The core is composed of the analog circuits which include the channel select MUX, the sample-and-hold (S/H) circuit, the successive approximation circuits, voltage reference circuits, and other analog support circuits. The wrapper is composed of the digital circuits that configure and control the ADC. These circuits include the logic for programmable conversions, result registers, interfaces to analog circuits, interfaces to the peripheral buses, post-processing circuits, and interfaces to other on-chip modules.

Each ADC module consists of a single sample-and-hold (S/H) circuit. The ADC module is designed to be duplicated multiple times on the same chip, allowing simultaneous sampling or independent operation of multiple ADCs. The ADC wrapper is start-of-conversion (SOC) based (see [Section 7.4.2.4](#)).

7.4.2.1.1 Features

Each ADC has the following features:

- 12-bit resolution
- Ratiometric external reference set by VREFHI and VREFLO pins
- Single-ended signal conversions
- Differential mode support
- Input multiplexer with up to 6 channels
- External channel mux option to expand available ADC channels
- 16 32 configurable SOCs
- 16 individually addressable result registers
- Two trigger repeater modules, enabling customizable hardware oversampling and undersampling modes with little or no CPU overhead
- Multiple trigger sources
 - S/W - software immediate start
 - All ePWMs - ADCSOC A or B
 - GPIO XINT2
 - RTI timer 0/1/2/3
 - ADCINT1/2
 - Input x-bar
 - ECAP events in capture mode (CEVT1, CEVT2, CEVT3, and CEVT4) and APWM mode (period match, compare match, or both)
- Four flexible PIE interrupts
- Burst mode
- Four post-processing blocks, each with:
 - Saturating offset calibration
 - Error from setpoint calculation
 - High, low, and zero-crossing compare, with interrupt and ePWM trip capability
 - Trigger-to-sample delay capture

Note

Not every channel may be pinned out from all ADCs. Check the device datasheet to determine which channels are available.

7.4.2.1.2 Block Diagram

Figure 7-84 shows the block diagram for the ADC core and ADC wrapper.

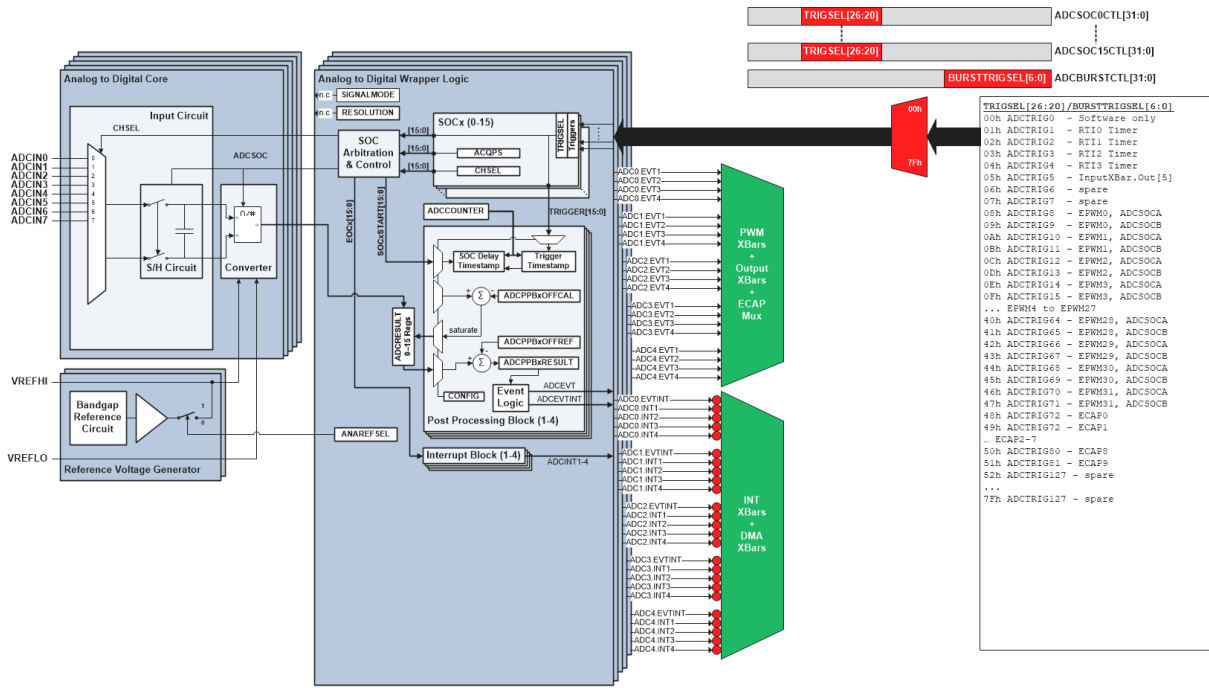

ADVANCE INFORMATION

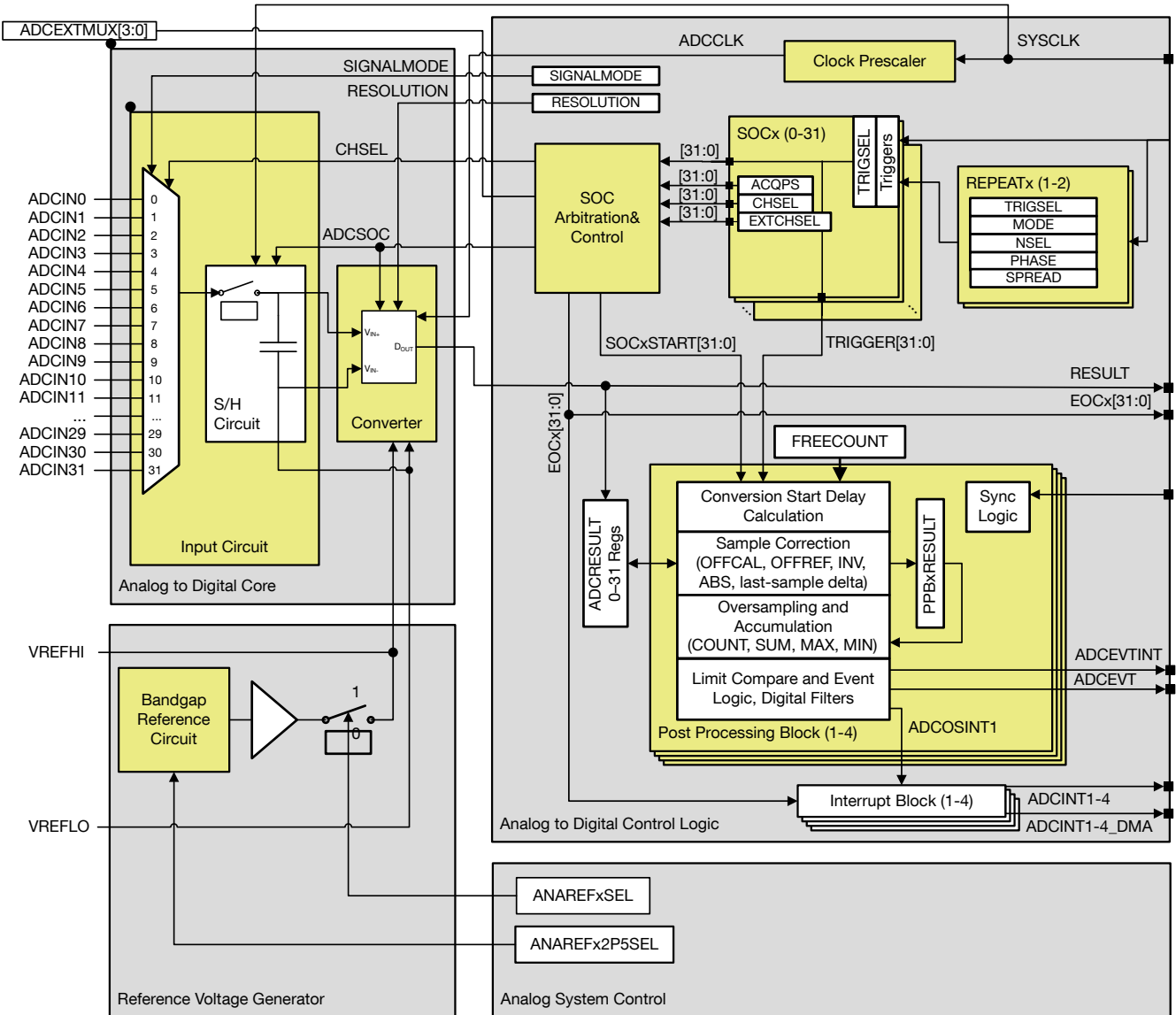

ADVANCE INFORMATION

Figure 7-84. ADC Module Block Diagram

Note

The ADC block diagram here reflects number of ADC channels internally configurable on the device. The actual number of available external ADC inputs will vary depending on part and package. See [#unique_559referenceTitle](#) for more information.

7.4.2.2 ADC Integration

There are 5x Analog-to-Digital Converter (ADC) modules integrated in the device. The diagram below provides a visual representation of the device integration details.

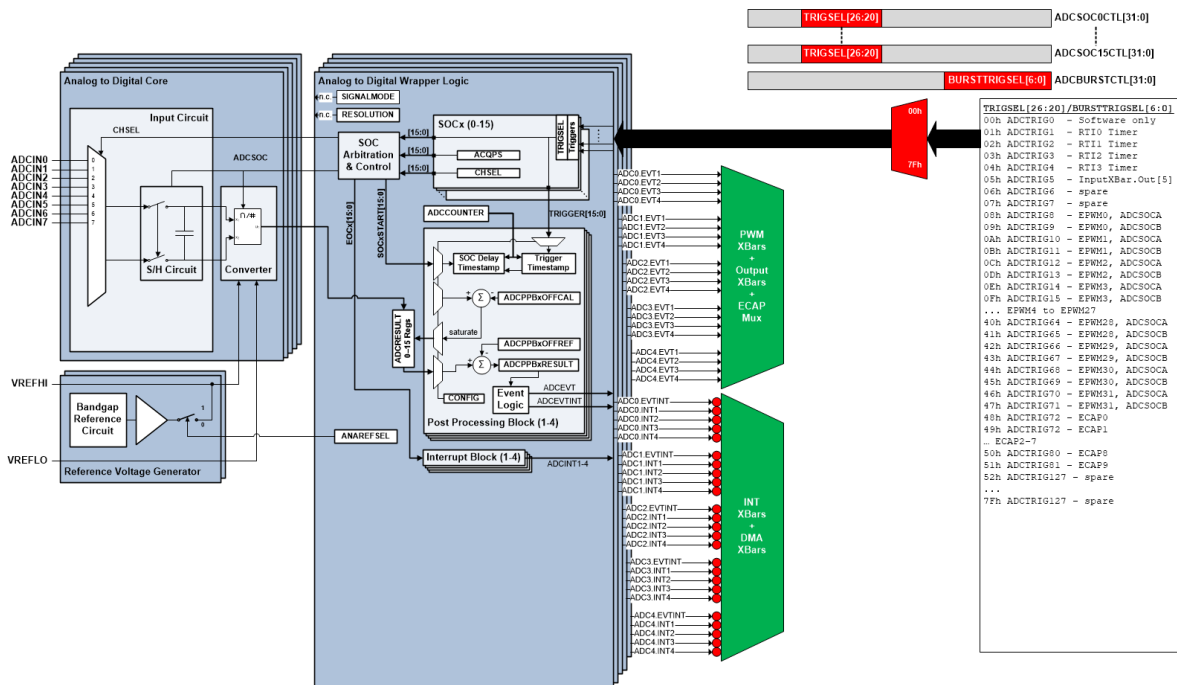

Figure 7-85. ADC Integration Diagram

ADVANCE INFORMATION

7.4.2.3 ADC Configurability

Some ADC configurations are individually controlled by the SOCs, while others are globally controlled per ADC module. [Table 7-97](#) summarizes the basic ADC options and their level of configurability. The subsequent sections discuss these configurations.

Table 7-97. ADC Options and Configuration Levels

Options	Configurability
Clock	Per module ⁽¹⁾
Resolution	Not configurable (12-bit only)
Signal mode	Per module
Reference voltage source	Not configurable (external reference only)
Trigger source	Per SOC ⁽¹⁾
Converted channel	Per SOC
Acquisition window duration	Per SOC ⁽¹⁾
EOC location	Per module
Burst Mode	Per module ⁽¹⁾

(1) Writing these values differently to different ADC modules could cause the ADCs to operate asynchronously. See [Section 7.4.2.13.1](#) for guidance on when the ADCs are operating synchronously or asynchronously.

7.4.2.3.1 Clock Configuration

The base ADC clock is provided directly by the system clock (SYSCLK). SYSCLK is used to generate the ADC acquisition window. The register ADCCTL2 has a PRESCALE field that determines the ADCCLK. The ADCCLK is used to clock the converter.

The core requires approximately 10.5 ADCCLK cycles to process a voltage into a conversion result. It is necessary for the user to determine the required duration of the acquisition window, see [Section 7.4.2.13.2](#).

Note

To determine an appropriate value for ADCCTL2.PRESCALE, see your device-specific datasheet to determine the maximum SYSCLK and ADCCLK frequency.

7.4.2.3.2 Resolution

The resolution of the ADC determines how finely the analog range is quantized into digital values. This ADC supports a resolution of 12 bits.

7.4.2.3.3 Voltage Reference

7.4.2.3.3.1 ADC Reference Buffer Control Registers

There are two internal ADC reference buffers in the device, REFBUF0 and REFBUF1, to provide precise reference of 1.8 V to ADC. REFBUF0 is associated with ADC0, ADC1, and ADC2. REFBUF1 is associated with ADC3 and ADC4.

The ADC can operate with the internal reference or an external reference. Both internal and external reference are connected to the same package balls. Only one reference can be active at any given time

ADC Reference connection is shown in [Figure 7-86](#).

The Voltage rails ADC_VREF*_G0 connects to REFBUF0, ADC0.

The voltage rails ADC_VREF*_G1 connects to ADC1 and ADC2.

The voltage rails ADC_VREF*_G2 connects to REFBUF1, ADC3, and ADC4

If internal reference is required to be used for ADC1 and ADC2, a board connection is provided to connect ADC_VREF*_G0 to ADC_VREF*_G1.

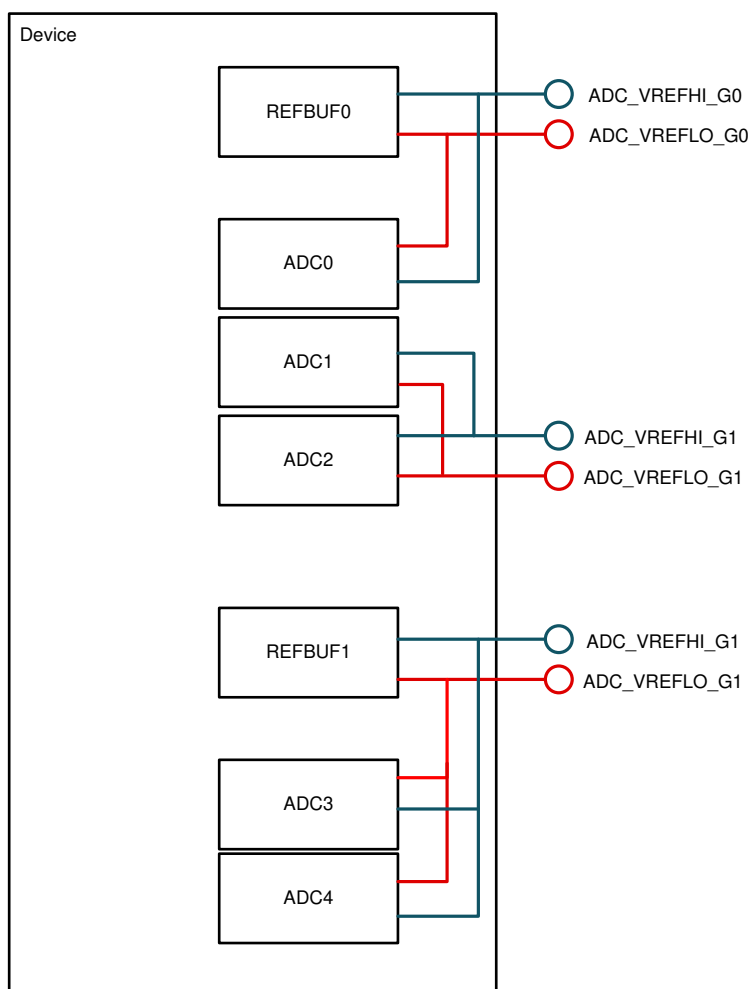

Figure 7-86. ADC Reference Connectivity Diagram

Internal reference are disabled by default. If external reference is not used, internal reference buffers can be enabled by the application for driving the ADC reference.

The ADC_REFBUF0_CTRL register is used to enable ADC Reference Buffer 0. Similarly, the ADC_REFBUF1_CTRL register is used to enable ADC Reference Buffer 1.

The MASK_ANA_ISO register must be set to 0x7 before ADC reference buffers are enabled. This prevents any undesirable behavior from voltage monitors triggering SOC reset.

Note

After the reference buffer is enabled, program the MASK_ANA_ISO back to 0x0 to re-enable the voltage monitors.

There are voltage monitors on all the three reference voltage rails for safe the reliable operation of ADC.

The ADC_REF_COMP_CTRL register is used to enable the reference monitor comparators.

ADC_REF_COMP_CTRL. ADC0_REFOK_EN enables the voltage monitor on ADC_VREF*_G0.

ADC_REF_COMP_CTRL. ADC12_REFOK_EN enables the voltage monitor on ADC_VREF*_G0.

ADC_REF_COMP_CTRL. ADC34_REFOK_EN enables the voltage monitor on ADC_VREF*_G0.

The status of the ADC reference rails is indicated in the ADC_REF_GOOD_STATUS register.

Note

ADC cannot be enabled without proper ADC voltage reference.

7.4.2.3.4 Signal Mode

The ADC supports two signal modes: single-ended and differential.

In single-ended mode, the input voltage to the converter is sampled through a single pin (ADCINx), referenced to VREFLO.

In differential signaling mode, the input voltage to the converter is sampled through a pair of input pins, one of which is the positive input (ADCINxP) and the other is the negative input (ADCINxN). The actual input voltage is the difference between the two (ADCINxP – ADCINxN).

- Each ADC has 6 selectable single ended or 3 selectable differential inputs
- 12 bit resolution with 4 MSPS sampling rate max.
- The 5x ADC's shall be grouped into two groups, Group 1 with 3x ADC and Group 2 with 2x ADC.
- Each group shall have an independent provision of external VREFHI/LO vs internal VREFHI/LO but will share the same VREF within the group. The Vref of the ADC can be independently qualified through internal monitors.
- All ADC can be operated asynchronously. However, if the ADC's within a group are operated synchronously (i.e start of conversion at the same time) the ADC-ADC noise isolation is better.
- Two common external calibration pins shall be provided for all ADC's which can be used to qualify ADC operation.
- ADC input shall tolerate a transient voltage overdrive with 10ma current limit per pin. In case of overdrive, ADC performance is not guaranteed and there will be a design limit on simultaneous pins being overdriven. It is desirable to saturate the ADC output during this condition.(Simulation and modeling challenges permitting).
- ADC input sampling has a scaling of 32/18 providing a full scale range of 3.2 V with 1.8V reference.

Internally generated VREFHI is 1.8V. Internal VREFHI has an accuracy error of 2%.

7.4.2.3.5 Reference

This section describes the ADC Modes of Operation.

Single-ended Mode:

The ADC output code is a 12-bit value, but internally it can generate slightly more than 12 effective data bits. There are operating modes that can be selected to clip and/or shift the ADC output to utilize different regions in SE (single-ended) mode. These modes can be selected by utilizing bits `adcX_cfg_1p1v[79:80]`. The default mode (00) simply clips the output within 0 and 4095 to maintain a 12 bit value; this effectively limits the maximum input of the ADC to 3.2V. The shifted mode (01) enables the ADC to effectively shift the input so that it creates a 12-bit output between 0.1V and 3.3V.

Table 7-98. ADC Output Code Clip and Shift Options

Input		Output (adcX_cfg_1p1v<80:79>)			
Equation	Input Voltage	Raw O/P	Scaled(10)	Shifted(01)	Default(00)
3.3/4224 * 0	0	0	0	0	0
3.3/4224 * 1	0.00078125	1	0	0	1
3.3/4224 * 2	0.0015625	2	1	0	2
3.3/4224 * 127	0.09921875	127	123	0	127
3.3/4224 * 128	0.1	128	124	0	128
3.3/4224 * 129	0.10078125	129	125	1	129
3.3/4224 * 4094	3.1984375	4094	3970	3966	4094
3.3/4224 * 4095	3.19921875	4095	3971	3967	4095
3.3/4224 * 4096	3.2	4096	3972	3968	4095
3.3/4224 * 4221	3.29765625	4221	4093	4093	4095

Table 7-98. ADC Output Code Clip and Shift Options (continued)

3.3/4224 * 4222	3.2984375	4222	4094	4094	4095
3.3/4224 * 4223	3.29921875	4223	4095	4095	4095

Differential Mode:

In differential mode ADC output code can be estimated using the following equation

$$\text{ADC Output Code} = \text{floor}((V_{\text{inpX}} - V_{\text{inmX}}) / \text{step_size} + 2112)$$

Where $\text{step_size} = (V_{\text{refP}} - V_{\text{refM}}) * 33 / 18 / 4224$

Please note the addition factor is 2112 as the ADC generates a full-scale code in raw o/p mode as 4223. This 64 LSB shift can be compensated if `adcX_cfg_1p1v[79:80]` is set to 01 in differential mode

Input Configuration:

The ADC can be operated in both single-ended and differential mode.

Table 7-99. ADC Input Selection Logic

<code>chsel_1p1v<2:0></code>	<code>diff_mode_1p1v=1</code>	<code>diff_mode_1p1v=0</code>
000	inp0-inm0	inp0
001	inm0-inp0	inm0
010	inp1-inm1	inp1
011	inm1-inp1	inm1
100	inp2-inm2	inp2
101	inm2-inp2	inm2
110	inp3-inm3	inp3
111	inm3-inp3	inm3

7.4.2.3.6 ADC Usage and Configuration Note

The bits `adcX_cfg_1p1v[79:80]` are common to all 5 ADC modules. Depending on the individual ADC (ADC0-ADC4) configuration (Single-ended or Differential) the module will behave according to following information.

ADC configured in Single-ended Mode:

- Selection=00: Normal ADC o/p [+0.0V = code 0 and +3.2V = code 4095]
- Selection=01: Shifted ADC o/p [+0.1V = code 0 and +3.3V = code 4095]
- Selection=01: Shifted ADC o/p [+0.1V = code 0 and +3.3V = code 4095]

(ADC input voltage range is shifted +100mV)

- Selection=10: Reserved
- Selection=11: Reserved

ADC configured in Differential Mode:

- Selection=00: Normal ADC Output with a code differential offset of 64. The output code rolls over above input 3.2V.

(A 3.2V to 3.3V input voltage will result in the same output code as 0-100mV input voltage)

- Selection=01: Normal Differential ADC Output

[-3.2V Differential = code 0 and +3.2V Differential = code 4095]

- Selection=10: Reserved
- Selection=11: Reserved

The `adcX_cfg_1p1v[79:80]` are not normally accessible, but can be overwritten by following the steps below. The bits in this and surrounding registers are critical for ADC functionality. Care must be taken so that only the

bits [79:80] are changed as desired, but all remaining bits remain unchanged and reflect the efuse programmed value.

1. Write to EFUSE_OVERRIDE_ADC_CFG2 (24 bit value corresponding to adc0_cfg_1p1v[64:87])
2. Write to EFUSE_OVERRIDE_ADC_CFG_CTRL for the override to take effect.

7.4.2.3.7 Interpreting Conversion Results

Based on a given ADC conversion result, the ideal corresponding analog input is given in [Table 7-100](#) and [Table 7-101](#). This corresponds to the center of the possible range of analog voltages that can have produced this conversion result.

Table 7-100. 12-Bit Digital-to-Analog Formulas

Digital Value	Analog Equivalent
when ADCRESULTy = 0	$ADCINx \leq VREFLO$ (2)
when $0 < ADCRESULTy < 4095$	$ADCINx = (VREFHI - VREFLO) \left(\frac{ADCRESULTy}{4096} \right) + VREFLO$
when ADCRESULTy = 4095	$ADCINx \geq VREFHI$ (3)

The ADC can be operated in both single-ended and differential mode; the inputs can be configured according to [Table 7-101](#).

Table 7-101. ADC Input Selection Logic

chsel_1p1v<2:0>	diff_mode_1p1v=1	diff_mode_1p1v=0
000	inp0-inm0	inp0
001	inm0-inp0	inm0
010	inp1-inm1	inp1
011	inm1-inp1	inm1
100	inp2-inm2	inp2
101	inm2-inp2	inm2
110	inp3-inm3	inp3
111	inm3-inp3	inm3

Single-ended Mode:

The ADC is designed for 12-bit output, but internally the ADC generates slightly more than 12 bits. There are certain modes that can be selected utilizing bits `adcX_cfg_1p1v<80:79>` to clip and shift the ADC output to utilize different regions in SE (single-ended) mode. The default mode (00) clips the output within 0 and 4095 to maintain a 12-bit value; this effectively limits the maximum input of the ADC to 3.2 V. In the shifted mode (01), the ADC effectively shifts the input so that the ADC creates a 12-bit output between 0.1 V and 3.3 V.

Input		Output (adcX_cfg_1p1v<80:79>)		
Equation	Input Voltage	Raw O/P	Shifted(01)	Default(00)
$3.3/4224 * 0$	0	0	0	0
$3.3/4224 * 1$	0.00078125	1	0	1
$3.3/4224 * 2$	0.0015625	2	0	2
$3.3/4224 * 127$	0.09921875	127	0	127
$3.3/4224 * 128$	0.1	128	0	128

Input		Output (adcX_cfg_1p1v<80:79>)		
Equation	Input Voltage	Raw O/P	Shifted(01)	Default(00)
3.3/4224 * 129	0.10078125	129	1	129
3.3/4224 * 4094	3.1984375	4094	3966	4094
3.3/4224 * 4095	3.19921875	4095	3967	4095
3.3/4224 * 4096	3.2	4096	3968	4095
3.3/4224 * 4221	3.29765625	4221	4093	4095
3.3/4224 * 4222	3.2984375	4222	4094	4095
3.3/4224 * 4223	3.29921875	4223	4095	4095

Differential Mode:

In differential mode ADC output code can be estimated using the following equation:

$$\text{ADC Output Code} = \text{floor}((\text{VinpX} - \text{VinnX}) / \text{step_size} + 2112)$$

Where $\text{step_size} = (\text{VrefP} - \text{VrefM}) * 33 / 18 / 4224$

Note the addition factor is 2112 as the ADC generates a full-scale code in raw o/p mode as 4223. This 64 LSB shift can be compensated if `adcX_cfg_1p1v<80:79>` is set to (01) in differential mode

The `adcX_cfg_1p1v<80:79>` is not normally accessible, but can be overwritten by following the below steps. The bits in this and surrounding registers are critical for ADC functionality. Care must be taken so that only the bits <80:79> are changed as desired, while remaining bits remain in the default programmed state.

- Write to `EFUSE_OVERRIDE_ADC_CFG2` (24-bit value corresponding to `adc0_cfg_1p1v<87:64>`)
- Write to `EFUSE_OVERRIDE_ADC_CFG_CTRL` for the override to take effect.

7.4.2.3.8 ADC-CMPSS Signal Connections

This table describes the connectivity between the ADC input signals/pins and the associated CMPSS signals.

Signal/Pin Name	ADC Input	CMPSS Input
ADC0_AIN0	ADC0:inp0 (+IN0)	CMPSSA0:inH (+IN)
ADC0_AIN1	ADC0:inm0 (-IN0)	CMPSSA0:inL (-IN)
ADC0_AIN2	ADC0:inp1 (+IN1)	CMPSSA1:inH (+IN)
ADC0_AIN3	ADC0:inm1 (-IN1)	CMPSSA1:inL (-IN)
ADC0_AIN4	ADC0:inp2 (+IN2)	CMPSSB0:inH/inL (+IN/-IN)
ADC0_AIN5	ADC0:inm2 (-IN2)	CMPSSB1:inH/inL (+IN/-IN)
ADC1_AIN0	ADC1:inp0 (+IN0)	CMPSSA2:inH (+IN)
ADC1_AIN1	ADC1:inm0 (-IN0)	CMPSSA2:inL (-IN)
ADC1_AIN2	ADC1:inp1 (+IN1)	CMPSSA3:inH (+IN)
ADC1_AIN3	ADC1:inm1 (-IN1)	CMPSSA3:inL (-IN)
ADC1_AIN4	ADC1:inp2 (+IN2)	CMPSSB2:inH/inL (+IN/-IN)
ADC1_AIN5	ADC1:inm2 (-IN2)	CMPSSB3:inH/inL (+IN/-IN)
ADC2_AIN0	ADC2:inp0 (+IN0)	CMPSSA4:inH (+IN)
ADC2_AIN1	ADC2:inm0 (-IN0)	CMPSSA4:inL (-IN)
ADC2_AIN2	ADC2:inp1 (+IN1)	CMPSSA5:inH (+IN)
ADC2_AIN3	ADC2:inm1 (-IN1)	CMPSSA5:inL (-IN)
ADC2_AIN4	ADC2:inp2 (+IN2)	CMPSSB4:inH/inL (+IN/-IN)
ADC2_AIN5	ADC2:inm2 (-IN2)	CMPSSB5:inH/inL (+IN/-IN)
ADC3_AIN0	ADC3:inp0 (+IN0)	CMPSSA6:inH (+IN)

This table describes the connectivity between the ADC input signals/pins and the associated CMPSS signals.

Signal/Pin Name	ADC Input	CMPSS Input
ADC3_AIN1	ADC3:inm0 (-IN0)	CMPSSA6:inL (-IN)
ADC3_AIN2	ADC3:inp1 (+IN1)	CMPSSA7:inH (+IN)
ADC3_AIN3	ADC3:inm1 (-IN1)	CMPSSA7:inL (-IN)
ADC3_AIN4	ADC3:inp2 (+IN2)	CMPSSB6:inH/inL (+IN/-IN)
ADC3_AIN5	ADC3:inm2 (-IN2)	CMPSSB7:inH/inL (+IN/-IN)
ADC4_AIN0	ADC4:inp0 (+IN0)	CMPSSA8:inH (+IN)
ADC4_AIN1	ADC4:inm0 (-IN0)	CMPSSA8:inL (-IN)
ADC4_AIN2	ADC4:inp1 (+IN1)	CMPSSA9:inH (+IN)
ADC4_AIN3	ADC4:inm1 (-IN1)	CMPSSA9:inL (-IN)
ADC4_AIN4	ADC4:inp2 (+IN2)	CMPSSB8:inH/inL (+IN/-IN)
ADC4_AIN5	ADC4:inm2 (-IN2)	CMPSSB9:inH/inL (+IN/-IN)
ADC_CAL0	ADC(0-4):inp3 (+IN3)	X
ADC_CAL1	ADC(0-4):inm3 (-IN3)	X

7.4.2.4 SOC Principle of Operation

The ADC triggering and conversion sequencing is accomplished through configurable start-of-conversions (SOCs). Each SOC is a configuration set defining the single conversion of a single channel. In that set there are three configurations: the trigger source that starts the conversion, the channel to convert, and the acquisition (sample) window duration. Upon receiving the trigger configured for a SOC, the wrapper will ensure that the specified channel is captured using the specified acquisition window duration.

Multiple SOCs can be configured for the same trigger, channel, and/or acquisition window as desired. Configuring multiple SOCs to use the same trigger will allow the trigger to generate a sequence of conversions. Configuring multiple SOCs to use the same trigger and channel will allow for oversampling.

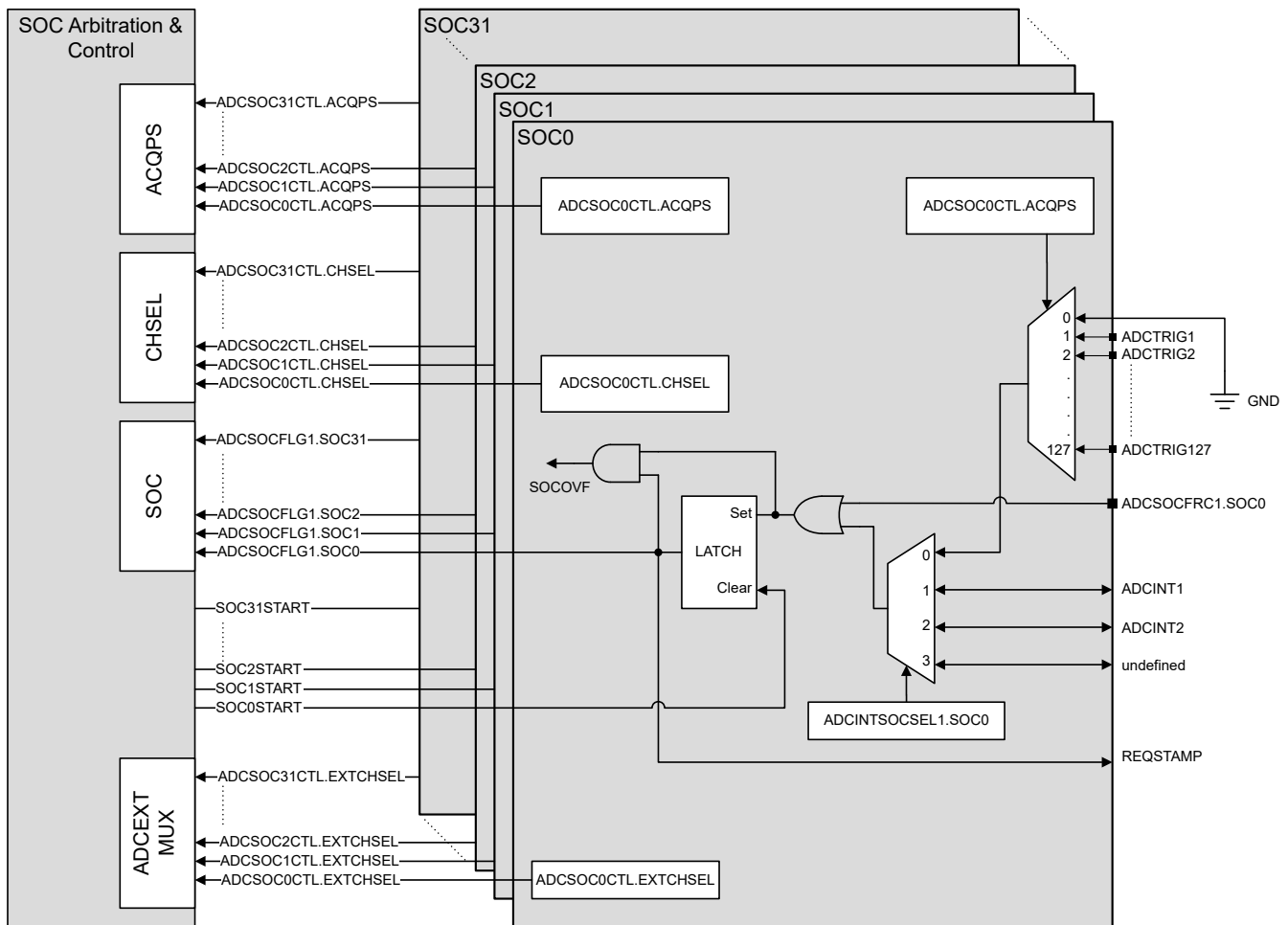

Figure 7-87. SOC Block Diagram

ADVANCE INFORMATION

7.4.2.4.1 SOC Configuration

Each SOC has its own configuration register, ADCSOCxCTL. Within this register, SOCx can be configured for trigger source, channel to convert, optional external channel mux selection, and acquisition (sample) window duration.

7.4.2.4.2 Trigger Operation

Each SOC can be configured to start on one of many input triggers. The primary trigger select for SOCx is in the ADCSOCxCTL.TRIGSEL register, which can select between:

- Disabled (software only)
- CPU Timers 0/1/2/3
- GPIO: Input X-Bar INPUT5
- ADCSOCA or ADCSOCB from each ePWM module
- eCAP events
- Either of the two trigger repeater blocks. This can be used to achieve oversampling, undersampling, or to apply a trigger delay.
- A global synchronous software trigger. This is achieved by configuring the ADCSOCFRCGBSEL and ADCSOCFRCGB analog subsystem registers.

In addition, each SOC can also be triggered when the ADCINT1 flag or ADCINT2 flag is set. This is achieved by configuring the ADCINTSOCSEL1 register (for SOC0 to SOC15) or the ADCINTSOCSEL2 register (for SOC16 and higher). This is useful for creating continuous conversions.

7.4.2.4.3 ADC Triggers

Table 7-102.

TRIGSEL[26:20]/ BURSTTRIGSEL[6:0]	ADC Trigger #	ADC Trigger Source
00h	ADCTRIG0	Software-Only Trigger
01h	ADCTRIG1	RTI0 Timer
02h	ADCTRIG2	RTI1 Timer
03h	ADCTRIG3	RTI2 Timer
04h	ADCTRIG4	RTI3 Timer
05h	ADCTRIG5	INPUTXBAR.OUT[5]
06h	ADCTRIG6	Unused
07h	ADCTRIG7	Unused
08h	ADCTRIG8	EPWM0 - ADCSOCA
09h	ADCTRIG9	EPWM0 - ADCSOCB
0Ah	ADCTRIG10	EPWM1 - ADCSOCA
0Bh	ADCTRIG11	EPWM1 - ADCSOCB
0Ch	ADCTRIG12	EPWM2 - ADCSOCA
0Dh	ADCTRIG13	EPWM2 - ADCSOCB
0Eh	ADCTRIG14	EPWM3 - ADCSOCA
0Fh	ADCTRIG15	EPWM3 - ADCSOCB
...	ADCTRIG[16:63]	EPWM[4:27] - ADCSOC[A:B]
40h	ADCTRIG64	EPWM28 - ADCSOCA
41h	ADCTRIG65	EPWM28 - ADCSOCB
42h	ADCTRIG66	EPWM29 - ADCSOCA

Table 7-102. (continued)

TRIGSEL[26:20]/ BURSTTRIGSEL[6:0]	ADC Trigger #	ADC Trigger Source
43h	ADCTRIG67	EPWM29 - ADCSOCB
44h	ADCTRIG68	EPWM30 - ADCSOCA
45h	ADCTRIG69	EPWM30 - ADCSOCB
46h	ADCTRIG70	EPWM31 - ADCSOCA
47h	ADCTRIG71	EPWM31 - ADCSOCB

7.4.2.4.4 ADC Acquisition (Sample and Hold) Window

External signal sources vary in their ability to drive an analog signal quickly and effectively. To achieve rated resolution, the signal source needs to charge the sampling capacitor in the ADC core to within 0.5 LSBs of the signal voltage. The acquisition window is the amount of time the sampling capacitor is allowed to charge and is configurable for SOCx by the ADCSOCxCTL.ACQPS register.

ACQPS is a 9-bit register that can be set to a value between 0 and 511, resulting in an acquisition window duration of:

$$\text{Acquisition window} = (\text{ACQPS} + 1) \cdot (\text{System Clock (SYSCLK) cycle time})$$

- The acquisition window duration is based on the System Clock (SYSCLK), not the ADC clock (ADCCLK).
- The selected acquisition window duration must be at least as long as one ADCCLK cycle.
- The data sheet specifies a minimum acquisition window duration (in nanoseconds). You are responsible for selecting an acquisition window duration that meets this requirement.
- For this design, the minimum ACQPS value that can be programmed is 16.

7.4.2.4.5 ADC Input Models

For single-ended operation, the ADC input characteristics for values in the single-ended input model (see Figure 7-88) can be found in the device-specific data sheet.

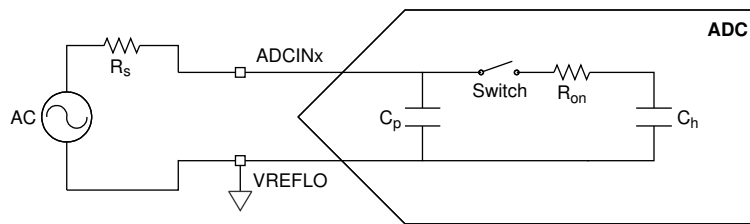

Figure 7-88. Single-Ended Input Model

For differential operation, the ADC input characteristics for values in the differential input model (see Figure 7-89) can be found in the device-specific data sheet.

These input models can be used along with actual signal source impedance to determine the acquisition window duration. See Section 7.4.2.13.2 for more information.

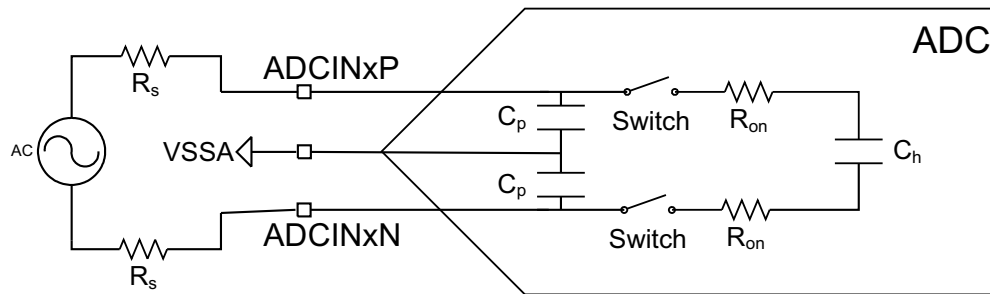

Figure 7-89. Differential Input Model

ADVANCE INFORMATION

7.4.2.4.6 Channel Selection

Each SOC can be configured to convert any of the ADC channels. This behavior is selected for SOCx by the ADCSOCxCTL.CHSEL register. Depending on the signal mode, the selection is different. For single-ended signal mode, the value in CHSEL selects a single pin as the input. For differential signal mode, the value in CHSEL selects an even-odd pin pair to be the positive and negative inputs. This is summarized in [Table 7-104](#).

Table 7-103. Channel Selection of Input Pins

Input Mode	CHSEL	Input	
Single-Ended	0	ADCIN0	
	1	ADCIN1	
	2	ADCIN2	
	3	ADCIN3	
	4	ADCIN4	
	5	ADCIN5	
	6	ADCIN6	
	7	ADCIN7	
	8	ADCIN8	
	9	ADCIN9	
	10	ADCIN10	
	11	ADCIN11	
	12	ADCIN12	
	13	ADCIN13	
	14	ADCIN14	
	15	ADCIN15	
	16 or 17	ADCIN16	ADCIN17
	18 or 19	ADCIN18	ADCIN19
	20 or 21	ADCIN20	ADCIN21
	22 or 23	ADCIN22	ADCIN23
24 or 25	ADCIN24	ADCIN25	
26 or 27	ADCIN26	ADCIN27	
28 or 29	ADCIN28	ADCIN29	
30 or 31	ADCIN30	ADCIN31	

Table 7-104. Channel Selection of Input Pins

Input Mode	CHSEL	Input
Single-Ended	0	ADCIN0
	1	ADCIN1
	2	ADCIN2
	3	ADCIN3
	4	ADCIN4
	5	ADCIN5
Differential	0	ADCIN0-ADCIN1
	1	ADCIN1-ADCIN0
	2	ADCIN2-ADCIN3
	3	ADCIN3-ADCIN2
	4	ADCIN4-ADCIN5
	5	ADCIN5-ADCIN4

7.4.2.5 SOC Configuration Examples

The following sections provide some specific examples of how to configure the SOC5s to produce some conversions.

7.4.2.5.1 Single Conversion from ePWM Trigger

SOC5 is chosen arbitrarily. Any of the 16 SOC5s could be used.

Assuming a 100 ns sample window is desired with a SYSCLK frequency of MHz, then the acquisition window duration should be cycles. The ACQPS field should therefore be set to .

As configured, when ePWM3 matches its period and generates the SOCB signal, the ADC will begin sampling channel ADCINA1 (SOC5) immediately if the ADC is idle. If the ADC is busy, ADCINA1 will begin sampling when SOC5 gains priority (see [Section 7.4.2.6](#)). The ADC control logic will sample ADCINA1 with the specified acquisition window width of 100 ns. Immediately after the acquisition is complete, the ADC will begin converting the sampled voltage to a digital value. When the ADC conversion is complete, the results will be available in the ADCRESULT5 register (see [Section 7.4.2.12](#) for exact sample, conversion, and result latch timings).

7.4.2.5.2 Oversampled Conversion from ePWM Trigger

To configure the ADC to oversample ADCINA1 4 times, we use the same configurations as the previous example, but apply them to SOC5, SOC6, SOC7, and SOC8.

As configured, when ePWM3 matches its period and generates the SOCB signal, the ADC will begin sampling channel ADCINA1 (SOC5) immediately if the ADC is idle. If the ADC is busy, ADCINA1 will begin sampling when SOC5 gains priority (see [Section 7.4.2.6](#)). Once the conversion is complete for SOC5, SOC6 will begin converting ADCINA1 and the results for SOC5 will be placed in the ADCRESULT5 register. All four conversions will eventually be completed sequentially, with the results in ADCRESULT5, ADCRESULT6, ADCRESULT7, and ADCRESULT8 for SOC5, SOC6, SOC7, and SOC8, respectively.

Note

It is possible, but unlikely, that the ADC could begin converting SOC6, SOC7, or SOC8 before SOC5 depending on the position of the round-robin pointer when the ePWM trigger is received. See [Section 7.4.2.6](#) to understand how the next SOC to be converted is chosen.

7.4.2.5.3 Multiple Conversions from CPU Timer Trigger

This example will show how to sample multiple signals with different acquisition window requirements. CPU1 Timer 2 will be used to generate the trigger. To see how to configure the CPU timer, see the *System Control and Interrupts* chapter.

A good first step when designing a sampling scheme with many signals is to list out the signals and their required acquisition window. From this, calculate the necessary number of SYSCLK cycles for each signal, then the ACQPS register setting. This is shown in , where a SYCLK of is assumed (cycle time).

Next decide which ADC pins to connect to each signal. This will be highly dependent on application board layout. Once the pins are selected, determining the value of CHSEL is straightforward (see [Table 7-105](#)).

Table 7-105. Example Connections for Multiple Signal Sampling

Signal Name	ADC Pin	CHSEL Register Value
Signal 1	ADCINA5	5
Signal 2	ADCINA0	0
Signal 3	ADCINA3	3
Signal 4	ADCINA2	2

With the information tabulated, it is easy to generate the SOC configurations:

```

AdcaRegs.ADCSOC0CTL.bit.CHSEL = 5;           //SOC0 will convert ADCINA5
AdcaRegs.ADCSOC0CTL.bit.ACQPS = 23;         //SOC0 will use sample duration of 24 SYSCLK cycles
AdcaRegs.ADCSOC0CTL.bit.TRIGSEL = 3;        //SOC0 will begin conversion on CPU1 Timer 2
AdcaRegs.ADCSOC1CTL.bit.CHSEL = 0;         //SOC1 will convert ADCINA0
AdcaRegs.ADCSOC1CTL.bit.ACQPS = 88;        //SOC1 will use sample duration of 89 SYSCLK cycles
AdcaRegs.ADCSOC1CTL.bit.TRIGSEL = 3;        //SOC1 will begin conversion on CPU1 Timer 2
AdcaRegs.ADCSOC2CTL.bit.CHSEL = 3;         //SOC2 will convert ADCINA3
AdcaRegs.ADCSOC2CTL.bit.ACQPS = 21;        //SOC2 will use sample duration of 22 SYSCLK cycles
AdcaRegs.ADCSOC2CTL.bit.TRIGSEL = 3;        //SOC2 will begin conversion on CPU1 Timer 2
AdcaRegs.ADCSOC3CTL.bit.CHSEL = 2;         //SOC3 will convert ADCINA2
AdcaRegs.ADCSOC3CTL.bit.ACQPS = 58;        //SOC3 will use sample duration of 59 SYSCLK cycles
AdcaRegs.ADCSOC3CTL.bit.TRIGSEL = 3;        //SOC3 will begin conversion on CPU1 Timer 2

```

As configured, when CPU1 Timer 2 generates an event, SOC0, SOC1, SOC2, and SOC3 will eventually be sampled and converted, in that order. The conversion results for ACINA5 (Signal 1) will be in ADCRESULT0. Similarly, The results for ADCINA0 (Signal 2), ADCINA3 (Signal 3), and ADCINA2 (Signal 4) will be in ADCRESULT1, ADCRESULT2, and ADCRESULT3, respectively.

Note

It is possible, but unlikely, that the ADC could begin converting SOC1, SOC2, or SOC3 before SOC0 depending on the position of the round-robin pointer when the CPU Timer trigger is received. See [Section 7.4.2.6](#) to understand how the next SOC to be converted is chosen.

7.4.2.5.4 Software Triggering of SOCs

At any point, whether or not the SOCs have been configured to accept a specific trigger, a software trigger can set the SOCs to be converted. This is accomplished by writing bits in the ADCSOCFRC1 register.

Software triggering of the previous example without waiting for the CPU1 Timer 2 to generate the trigger could be accomplished by the statement:

```
AdcaRegs.ADCSOCFRC1.all = 0x000F;           //set SOC flags for SOC0 to SOC3
```

7.4.2.6 ADC Conversion Priority

When multiple SOC flags are set at the same time, one of two forms of priority determines the order in which they are converted. The default priority method is round robin. In this scheme, no SOC has an inherent higher priority than another. Priority depends on the round robin pointer (RRPOINTER). The RRPOINTER reflected in the ADCSOCPRIORITYCTL register points to the last SOC converted. The highest priority SOC is given to the next value greater than the RRPOINTER value, wrapping around back to SOC0 after SOC15. At reset the value is 16 since 0 indicates a conversion has already occurred. When RRPOINTER equals 16 the highest priority is given to SOC0. The RRPOINTER is reset when the ADC module is reset or when the SOCPRICTL register is written. The ADC module is reset by writing and clearing the SOFTPRES bit corresponding to the ADC instance.

An example of the round robin priority method is given in [Figure 7-90](#).

The SOCPRIORITY field in the ADCSOCPRIORITYCTL register can be used to assign high priority from a single to all of the SOCs. When configured as high priority, an SOC will interrupt the round robin wheel after any current conversion completes and insert itself in as the next conversion. After its conversion completes, the round robin wheel will continue where it was interrupted. If two high priority SOC's are triggered at the same time, the SOC with the lower number will take precedence.

High priority mode is assigned first to SOC0, then in increasing numerical order. The value written in the SOCPRIORITY field defines the first SOC that is not high priority. In other words, if a value of 4 is written into SOCPRIORITY, then SOC0, SOC1, SOC2, and SOC3 are defined as high priority, with SOC0 the highest.

An example using high priority SOC's is given in [Figure 7-91](#).

- A** After reset, SOC0 is highest priority SOC ; SOC7 receives trigger ; SOC7 configured channel is converted immediately .
- B** RRPOINTER changes to point to SOC 7 ; SOC8 is now highest priority SOC .
- C** SOC2 & SOC12 triggers rcvd . simultaneously ; SOC12 is first on round robin wheel ; SOC12 configured channel is converted while SOC2 stays pending .
- D** RRPOINTER changes to point to SOC 12 ; SOC2 configured channel is now converted .
- E** RRPOINTER changes to point to SOC 2 ; SOC3 is now highest priority SOC .

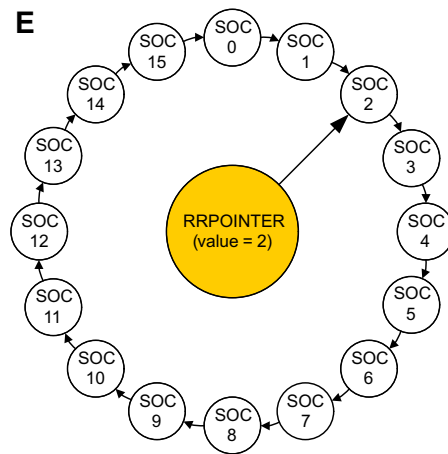
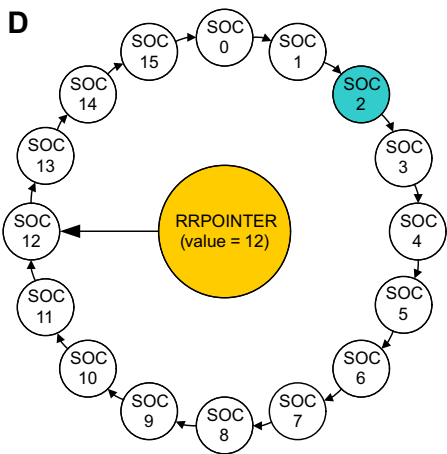
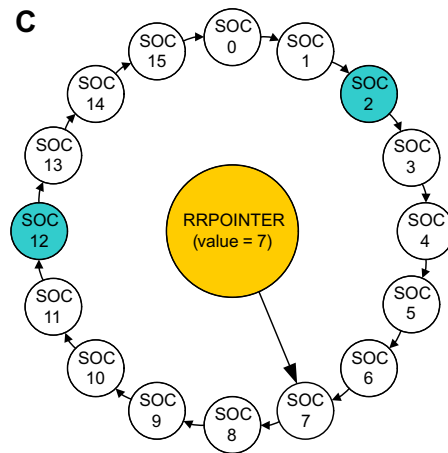
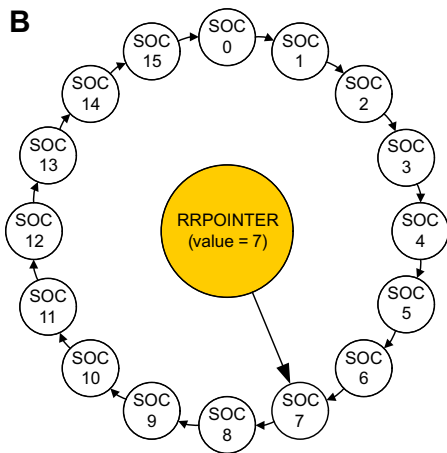
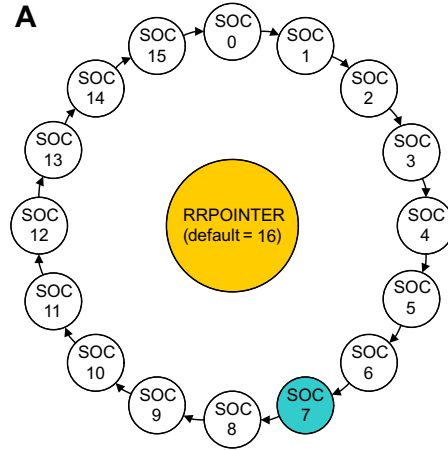

Figure 7-90. Round Robin Priority Example

Example when SOC PRIORITY = 4

- A After reset, SOC4 is 1st on round robin wheel ; SOC7 receives trigger ; SOC7 configured channel is converted immediately .
- B RRPOINTER changes to point to SOC 7 ; SOC8 is now 1st on round robin wheel .
- C SOC2 & SOC12 triggers rcvd . simultaneously ; SOC2 interrupts round robin wheel and SOC 2 configured channel is converted while SOC 12 stays pending .
- D RRPOINTER stays pointing to 7 ; SOC12 configured channel is now converted .
- E RRPOINTER changes to point to SOC 12 ; SOC13 is now 1st on round robin wheel .

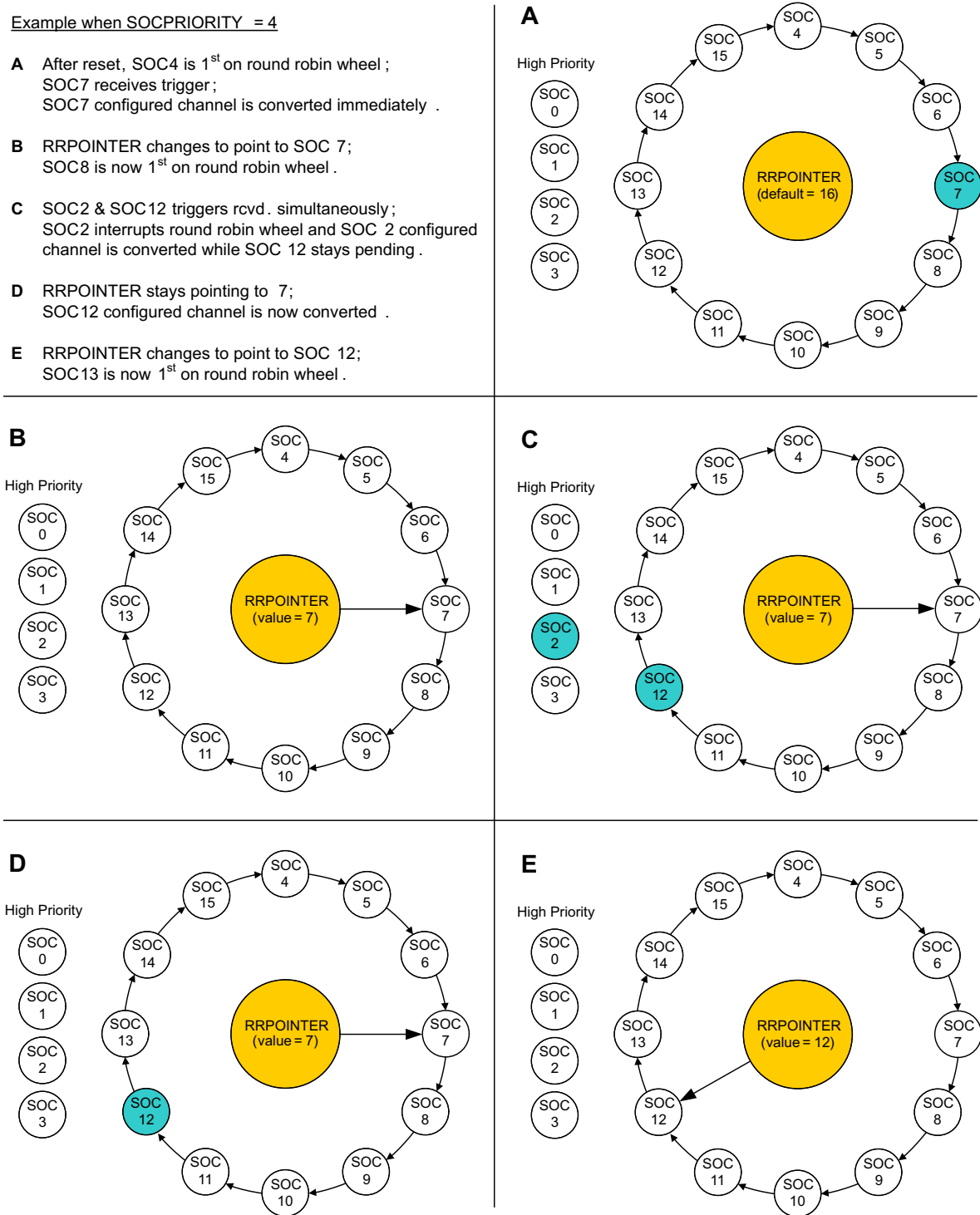

Figure 7-91. High Priority Example

7.4.2.7 Burst Mode

Burst mode allows a single trigger to walk through the round-robin SOCs one or more at a time. Setting the bit BURSTEN in the ADCBURSTCTL register configures the ADC wrapper for burst mode. This causes the TRIGSEL field to be ignored, but only for SOCs that are configured for round-robin operation (not high priority). Instead of the TRIGSEL field, all round-robin SOCs are triggered based on the BURSTTRIG field in the ADCBURSTCTL register. Upon reception of the burst trigger, the ADC wrapper will not set all round-robin SOCs to be converted, but only (ADCBURSTCTL.BURSTSIZE + 1) SOCs. The first SOC to be set will be that with the highest priority based on the round-robin pointer, and subsequent SOCs will be set until BURSTSIZE SOCs have been set.

Note

When configuring the ADC for burst mode, the user is responsible for ensuring that each burst of conversions is allowed to complete before the next burst trigger is received. If the previous burst is not complete at the time when a new burst trigger arrives, for each SOC that was already pending and receives a new trigger, the corresponding overflow flag in ADCSOCOVF1 will be set.

For example, if SOCPRIORITY = 12, that is, SOC12, SOC13, SOC14, and SOC15 are in round-robin, ADCBURSTCTL.BURSTSIZE setting should be ≤ 3 for burst mode to operate correctly.

7.4.2.7.1 Burst Mode Example

Burst mode can be used to sample a different set of signals on every other trigger. In the following example, ADCIN7 and ADCIN5 are converted on the first trigger from CPU1 Timer 2 and every other trigger thereafter. ADCIN2 and ACIN3 are converted on the second trigger from CPU1 Timer 2 and every other trigger thereafter. All signals are converted with 20 SYSCLK cycle wide acquisition windows, but different durations could be configured for each SOC as desired.

```
AdcaRegs.BURSTCTL.BURSTEN = 1;           //Enable ADC burst mode
AdcaRegs.BURSTCTL.BURSTTRIG = 3;         //CPU1 Timer 2 will trigger burst of conversions
AdcaRegs.BURSTCTL.BURSTSIZE = 1;         //conversion bursts are 1 + 1 = 2 conversions long
AdcaRegs.SOCPRICRTL.bit.SOCPRIORITY = 12; //SOC0 to SOC11 are high priority
AdcaRegs.ADCSOC12CTL.bit.CHSEL = 7;      //SOC12 will convert ADCINA7
AdcaRegs.ADCSOC12CTL.bit.ACQPS = 19;     //SOC12 will use sample duration of 20 SYSCLK cycles
AdcaRegs.ADCSOC13CTL.bit.CHSEL = 5;      //SOC13 will convert ADCINA5
AdcaRegs.ADCSOC13CTL.bit.ACQPS = 19;     //SOC13 will use sample duration of 20 SYSCLK cycles
AdcaRegs.ADCSOC14CTL.bit.CHSEL = 2;      //SOC14 will convert ADCINA2
AdcaRegs.ADCSOC14CTL.bit.ACQPS = 19;     //SOC14 will use sample duration of 20 SYSCLK cycles
AdcaRegs.ADCSOC15CTL.bit.CHSEL = 3;      //SOC15 will convert ADCINA3
AdcaRegs.ADCSOC15CTL.bit.ACQPS = 19;     //SOC15 will use sample duration of 20 SYSCLK cycles
```

When the first CPU1 Timer 2 trigger is received, SOC12 and SOC13 will be converted immediately if the ADC is idle. If the ADC is busy, SOC12 and SOC13 will be converted once their SOCs gain priority. The results for SOC12 and SOC13 will be in ADCRESULT12 and ADCRESULT13, respectively. After SOC13 completes, the round robin pointer will give highest priority to SOC14. Because of this, when the next CPU1 Timer 2 trigger is received, SOC14 and SOC15 will be set as pending and eventually be converted. The results for SOC14 and SOC15 will be in ADCRESULT14 and ADCRESULT15, respectively. Subsequent triggers will continue to toggle between converting SOC12 and SOC13, and converting SOC14 and SOC15.

While the above example toggles between two sets of conversions, three or more different sets of conversions could be achieved using a similar approach.

7.4.2.7.2 Burst Mode Priority Example

An example of priority resolution using burst mode and high-priority SOC's is presented in Figure 7-92.

Example when SOC PRIORITY = 4, BURSTEN = 1, and BURSTSIZE = 1

- A After reset, SOC4 is 1st on round robin wheel; BURSTTRIG trigger is received; SOC4 & SOC5 are set and configured channels converted immediately.
- B RRPOINTER changes to point to SOC5; SOC6 is now 1st on round robin wheel.
- C BURSTTRIG & SOC1 triggers rcvd. simultaneously; SOC1, SOC6, and SOC7 are set; SOC1 interrupts round robin wheel and SOC1 configured channel is converted while SOC6 and SOC7 stay pending.
- D RRPOINTER stays pointing to 5; SOC6/SOC7 configured channels are now converted.
- E RRPOINTER changes to point to SOC7; SOC8 is now 1st on round robin wheel, waiting for BURSTTRIG.

ADVANCE INFORMATION

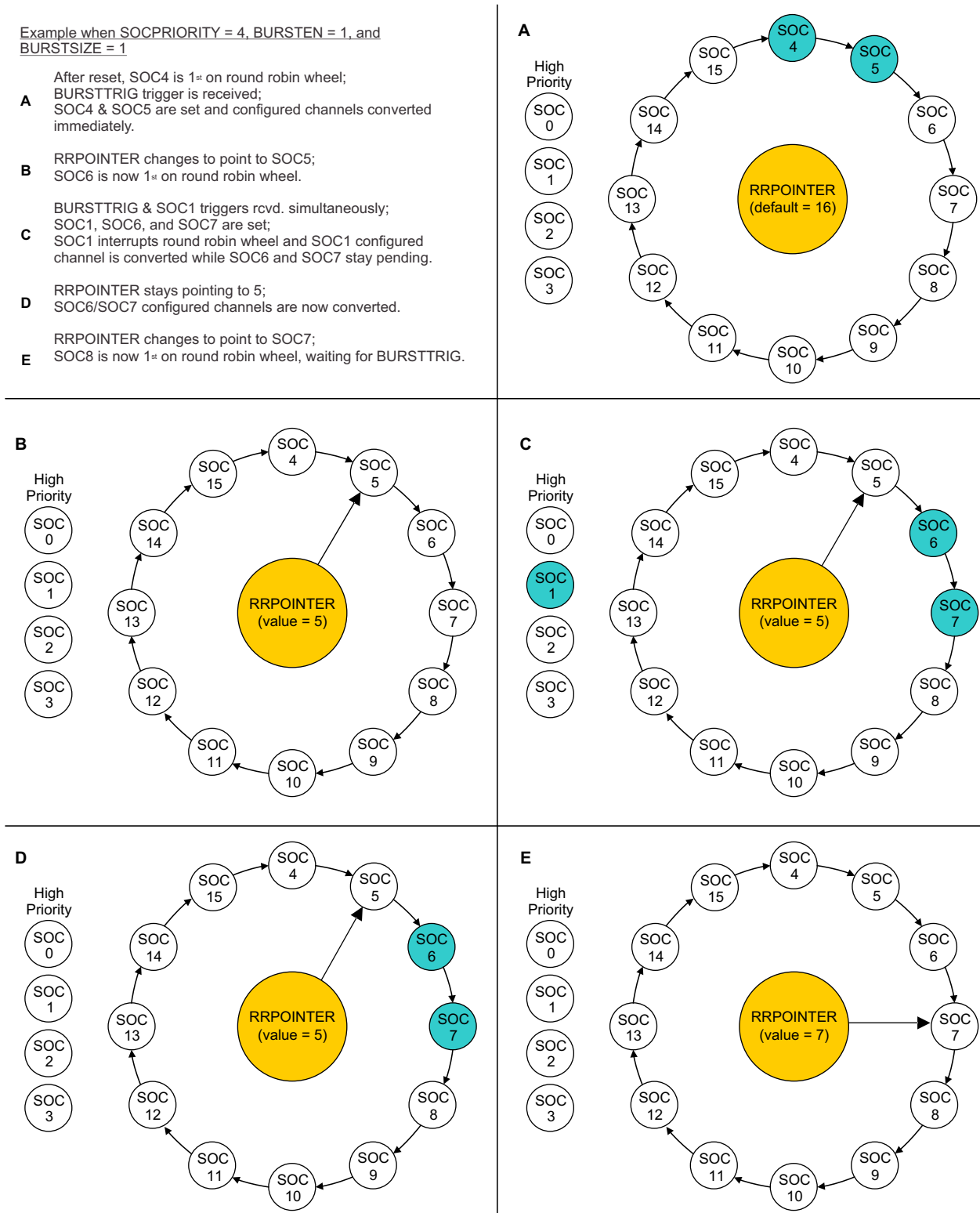

Figure 7-92. Burst Priority Example

7.4.2.8 EOC and Interrupt Operation

Each SOC has a corresponding end-of-conversion (EOC) signal. This EOC signal can be used to trigger an ADC interrupt. The ADC can be configured to generate the EOC pulse at either the end of the acquisition window or at the end of the voltage conversion. This is configured using the bit INTPULSEPOS in the ADCCTL1 register. See Section 7.4.2.12 for exact EOC pulse location.

Each ADC module has 4 configurable ADC interrupts. These interrupts can be triggered by any of the 16 EOC signals. The flag bit for each ADCINT can be read directly to determine if the associated SOC is complete or the interrupt can be passed on to the PIE. Each ADCINT flag also has a corresponding ADCINTxRESULT flag. The ADCINTxRESULT flag is only set when results corresponding to the EOC are latched. This is useful for interrupt service routines or CLA tasks with early interrupt timing configured, allowing the application code to perform some pre-processing or setup work, and then acting on the ADC conversion result as soon as it is latched.

It is also possible to generate an ADC interrupt based on an oversampling logic event, such as when the sample count matches the configured limit. There are four oversampling interrupt (OSINT) flags available in each module for this purpose. Any of the ADCINT flags may be configured for an OSINT by configuring the INTxSEL field the corresponding ADCINTSELxNy register.

Note

The ADCCTL1.ADCBSY bit being clear does not indicate that all conversions in a set of SOCs have completed, only that the ADC is ready to process the next conversion. To determine if a sequence of SOCs is complete, link an ADCINT flag to the last SOC in the sequence and monitor that ADCINT flag.

Figure 7-93 shows a block diagram of the ADC interrupt structure.

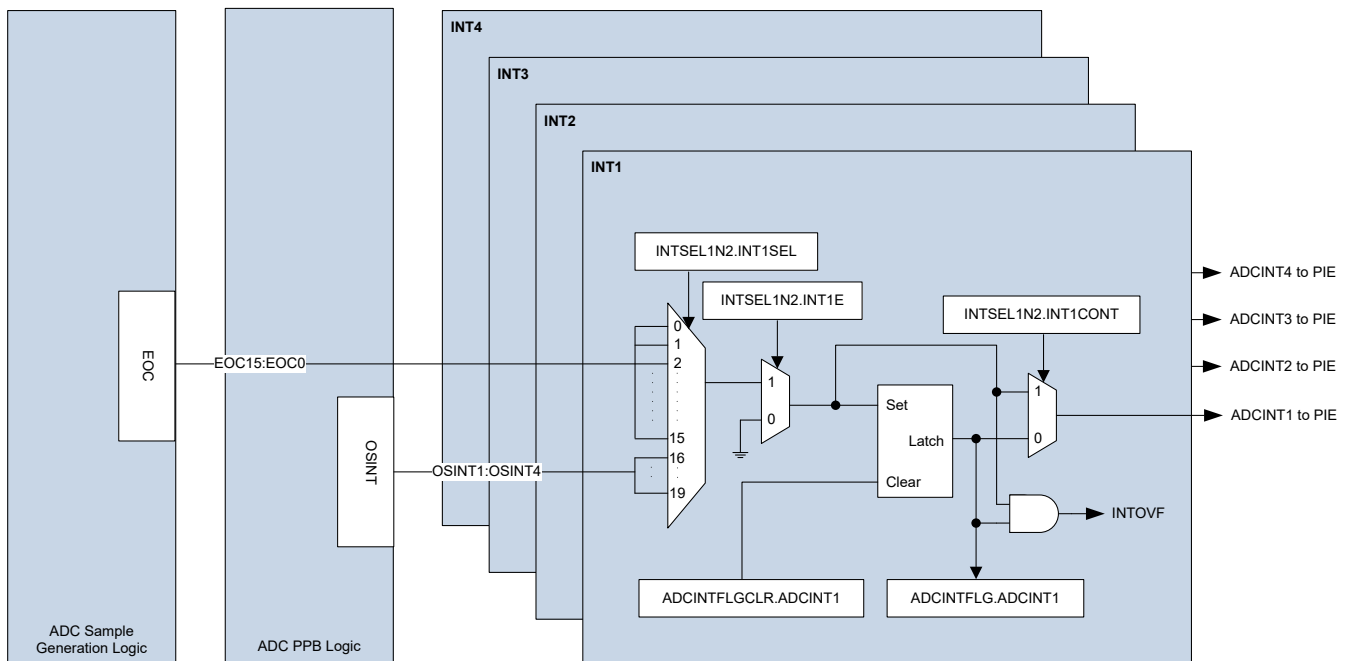

Figure 7-93. ADC EOC Interrupts

7.4.2.8.1 Interrupt Overflow

If the EOC signal would set a flag in the ADCINTFLG register, but that flag is already set, an interrupt overflow occurs. By default, overflow interrupts will not be passed on to the PIE module. When an overflow occurs on a given flag in the ADCINTFLG register, the corresponding flag in the ADCINOVF register is set. This overflow flag is only used to detect that an overflow has occurred; it does not block further interrupts from propagating to the PIE module.

When an ADC interrupt overflow could occur, the application should check the appropriate ADCINTOVF flag inside the ISR or in the background loop and take appropriate action when an overflow is detected. The following code snippets demonstrate how to check the ADCINOVF flag inside the ISR after attempting to clear the ADCINT flag.

```
// Clear the interrupt flag
AdcaRegs.ADCINTFLGCLR.bit.ADCINT1 = 1;    //clear INT1 flag for ADC-A

// Check if an overflow has occurred
if(1 == AdcaRegs.ADCINTOVF.bit.ADCINT1)    //ADCINT overflow occurred
{
    AdcaRegs.ADCINTOVFCLR.bit.ADCINT1 = 1  //Clear overflow flag
    AdcaRegs.ADCINTFLGCLR.bit.ADCINT1 = 1  //Re-clear ADCINT flag
}
```

```
//
// Clear the interrupt flag
//
ADC_clearInterruptStatus(ADCA_BASE, ADC_INT_NUMBER1);

//
// Check if an overflow has occurred
//
if(true == ADC_getInterruptOverflowStatus(ADCA_BASE, ADC_INT_NUMBER1))
{
    ADC_clearInterruptOverflowStatus(ADCA_BASE, ADC_INT_NUMBER1);
    ADC_clearInterruptStatus(ADCA_BASE, ADC_INT_NUMBER1);
}
```

7.4.2.8.2 Continue to Interrupt Mode

The INTxCONT bits in the ADCINTSEL1N2 and ADCINTSEL3N4 registers configure how interrupts are handled when an ADCINTFLG has not yet been cleared from a prior interrupt. This mode is disabled by default and additional overlapping interrupts will not be issued to the PIE. By activating this mode ADC interrupts will always reach the PIE. The ADCINTOVF register will still be set if an interrupts occur while ADCINTFLG is still set regardless of this configuration.

7.4.2.9 Post-Processing Blocks

Each ADC module contains four post-processing blocks (PPB). These blocks can be associated with any of the 16 RESULT registers using the ADCPPBxCONFIG.CONFIG bit field. The post-processing blocks have the ability to:

- Remove an offset associated with the ADCIN channel
- Subtract out a reference value
- Compute the delta between the current conversion result and the previous conversion.
- Aggregate successive samples via sum, max and/or min calculations
- Automatically calculate average of oversampled conversions without CPU overhead, when sample count is a power of 2
- Transform the conversion result into its absolute value
- Flag a zero-crossing point, with the option to trip a PWM and/or generate an interrupt
- Flag a high or low compare limit, with the option to trip a PWM and/or generate an interrupt
- Digitally filter high or low compare results, to help prevent unwanted threshold trips
- Record the delay between the associated SOC trigger and when sampling actually begins

Figure 7-94 presents the structure of each PPB. Subsequent sections explain the use of each submodule.

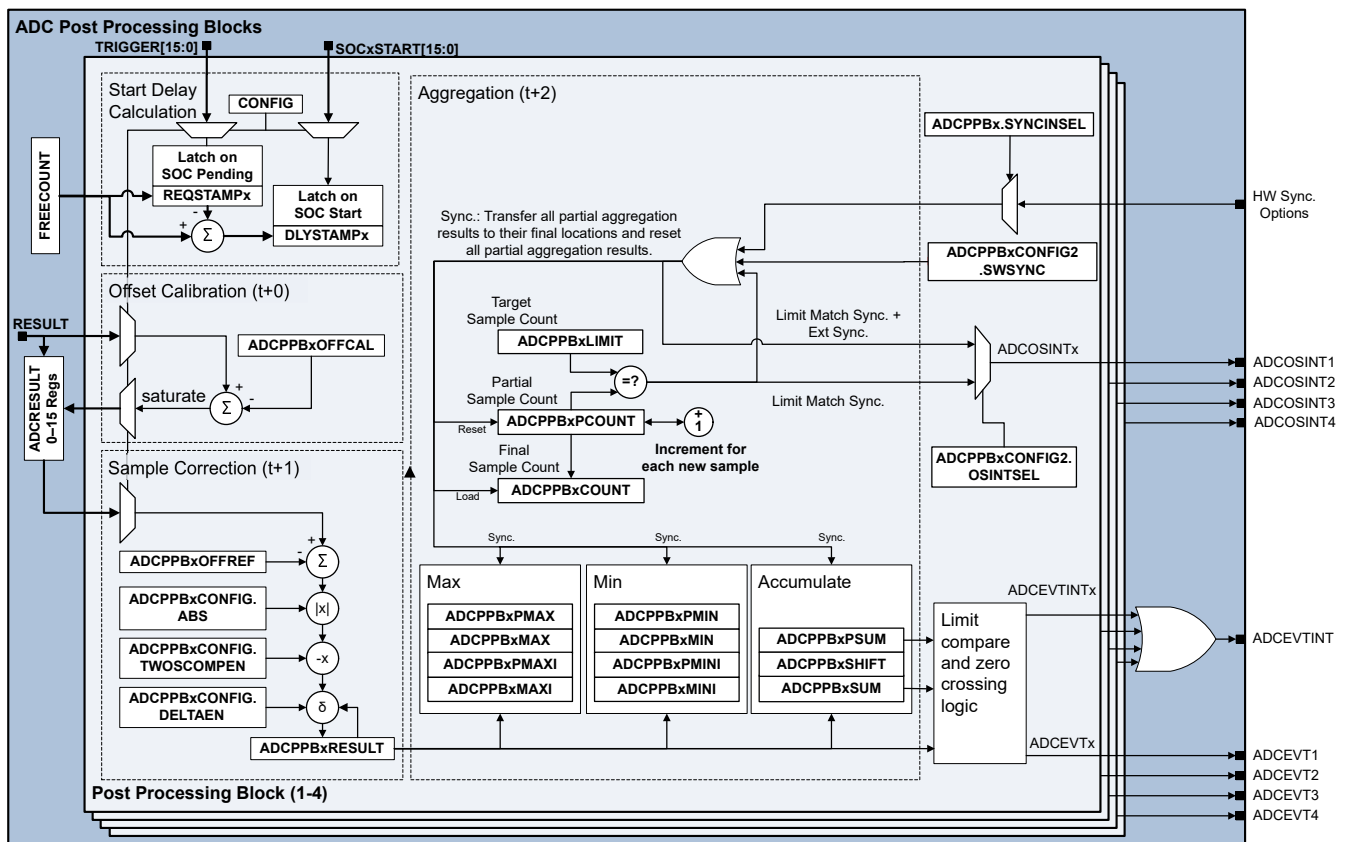

Figure 7-94. ADC PPB Block Diagram

ADVANCE INFORMATION

7.4.2.9.1 PPB Offset Correction

In many applications, external sensors and signal sources produce an offset. A global trimming of the ADC offset is not enough to compensate for these offsets, which vary from channel to channel. The post-processing block can remove these offsets with zero overhead, saving numerous cycles in tight control loops.

Offset correction is accomplished by first pointing the ADCPPBxCONFIG.CONFIG to the desired SOC, then writing an offset correction value to the ADCPPBxOFFCAL.OFFCAL register. The post-processing block will automatically add or subtract the value in the OFFCAL register from the raw conversion result and store it in the ADCRESULT register.

Note

- Writing a 0 to the OFFCAL register effectively disables the offset correction feature, passing the raw result unchanged to the ADCRESULT register.
 - It is possible to point multiple PPBs to the same SOC. In this case, the OFFCAL value that is actually applied will come from the PPB with the lowest number.
-

7.4.2.9.2 PPB Error Calculation

In many applications, an error from a setpoint or expected value must be computed from the digital output of an ADC conversion. In other cases, a bipolar signal is necessary or convenient for control calculations. The PPB can perform these functions automatically, reducing the sample to output latency and reducing software overhead.

Error calculation is accomplished by first pointing the ADCPPBxCONFIG.CONFIG to the desired SOC, then writing a value to the ADCPPBxOFFCAL.OFFREF register. The post-processing block will automatically subtract the value in the OFFREF register from the ADCRESULT value and store it in the ADCPPBxRESULT register. This subtraction will produce a sign-extended 32-bit result. It is also possible to selectively invert the calculated value before storing in the ADCPPBxRESULT register by setting the TWOSCOMPEN bit in the ADCPPBxCONFIG register.

If desired, the absolute value of the ADC result after the offset reference calculation can be obtained by setting the ADCPPBxCONFIG.ABSEN bit. The absolute value is computed before evaluating the TWOSCOMPEN logic, so setting both TWOSCOMPEN and ABSEN will always result in a negative value stored in ADCPPBxRESULT.

Note

- not write a value larger than 12 bits to the OFFREF register.
 - Since the PPBxRESULT register is unique for each PPB, it is possible to point multiple PPBs to the same SOC and get different results for each PPB.
 - Writing a 0 to the OFFREF register effectively disables the error calculation feature, passing the ADCRESULT value unchanged to the ADCPPBxRESULT register.
-

7.4.2.9.3 PPB Limit Detection and Zero-Crossing Detection

Many applications perform a limit check against the ADC conversion results. The PPB can automatically perform a check against high and low limits, or whenever ADCPPBxRESULT changes sign. Based on these comparisons, it can generate a trip to the PWM and/or an interrupt automatically, lowering the sample to ePWM latency and reducing software overhead. This functionality also enables safety-conscious applications to trip the ePWM based on an out-of-range ADC conversion without any CPU intervention.

To enable this functionality, first point the ADCPPBxCONFIG.CONFIG to the desired SOC, then write a value to one or both of the registers ADCPPBxTRIPHI.LIMITHI and ADCPPBxTRIPLO.LIMITLO (zero-crossing detection does not require further configuration). Whenever these limits are exceeded, the PPBxTRIPHI

bit or PPBxTRIPLO bit will be set in the ADCEVTSTAT register. Note that the PPBxZERO bit in the ADCEVTSTAT register is gated by end-of-conversion (EOC), not by the sign change in the ADCPPBxRESULT register. The ADCEVTCLR register has corresponding bits to clear these event flags. The ADCEVTSEL register has corresponding bits which allow the events to propagate through to the PWM. The ADCINTSEL register has corresponding bits which allow the events to propagate through to the PIE. [#unique_593/unique_593_Connect_42_FIG_GVQ_GYP_MTBreferenceTitle](#) illustrates the ADC limit compare and zero-crossing logic.

One PIE interrupt is shared between all the PPBs for a given ADC module as shown in [Figure 7-95](#).

Note

- If different actions need to be taken for different PPB events from the same ADC module, then the ADCEVTINT ISR will have to read the PPB event flags in the ADCEVTSTAT register to determine which event caused the interrupt.
- If different ePWM trips need to be generated separately for high compare, low compare, and/or zero-crossing, this can be achieved by pointing multiple PPBs to the same SOC.
- The zero-crossing detect circuit considers a result of zero to be positive.

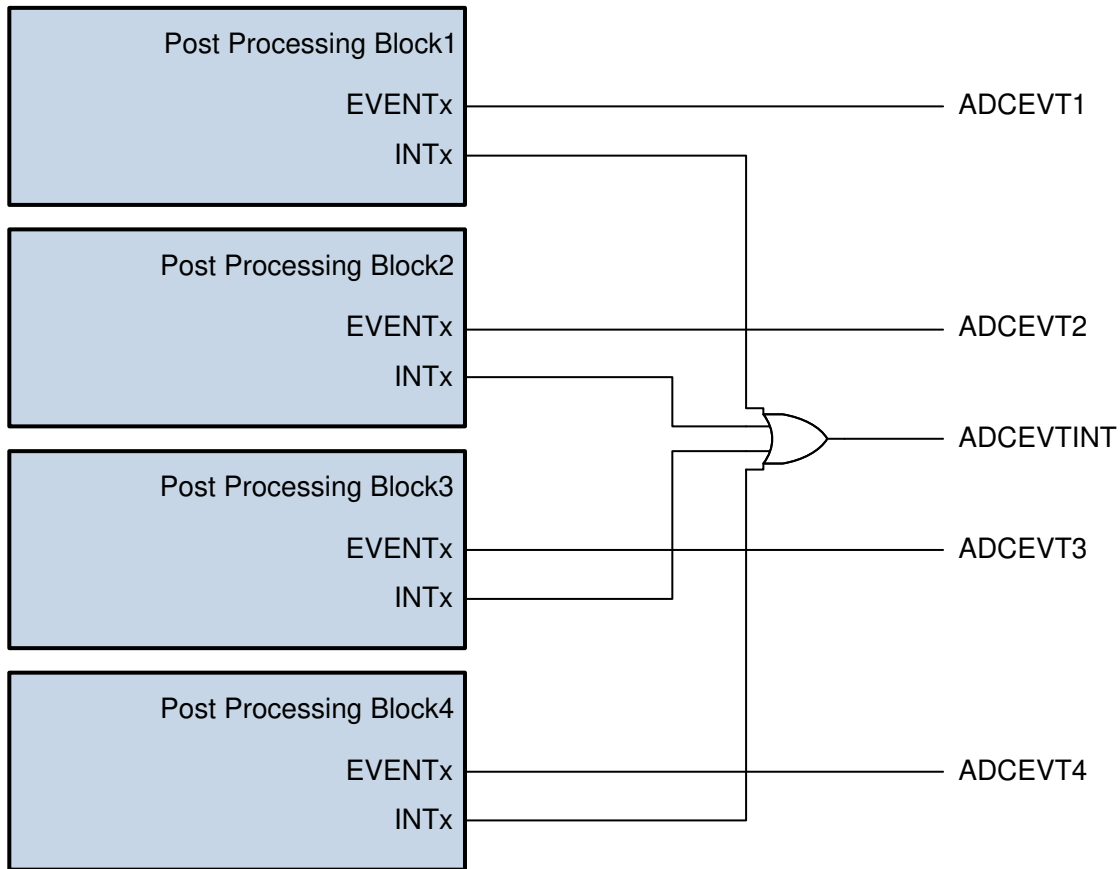

Figure 7-95. ADC PPB Interrupt Event

7.4.2.9.4 PPB Sample Delay Capture

When multiple control loops are running asynchronously on the same ADC, there is a chance that an ADC request from two or more loops will collide, causing one of the samples to be delayed. This shows up as a measurement error in the system. By knowing when this delay occurs and the amount of delay that has occurred software can employ extrapolation techniques to reduce the error.

To this effect, each PPB has the field DLYSTAMP in the ADCPPBxSTAMP register. This field will contain the number of SYSCLK cycles between when the associate SOC was triggered and when it began converting.

This is achieved by having a global 12-bit free running counter based off of SYSCLK, which is in the field FREECOUNT in the ADCCOUNTER register. When the trigger for the associated SOC arrives, the value of this counter is loaded into the bit field ADCPPBxTRIPLO.REQSTAMP. When the actual sample window for that SOC begins, the value in REQSTAMP is subtracted from the current FREECOUNT value and stored in DLYSTAMP.

Note

If more than 4096 SYSCLK cycles elapse between the SOC trigger and the actual start of the SOC acquisition, the FREECOUNT register may overflow more than once, leading to incorrect DLYSTAMP value. Be cautious when using very slow conversions to prevent this from happening.

The sample delay capture will not function if the associated SOC is triggered via software. It will, however, correctly record the delay if the software triggering of a different SOC causes the SOC associated with the PPB to be delayed

7.4.2.10 Power-Up Sequence

Upon device power-up or system level reset, the ADC will be powered down and disabled. When powering up the ADC, use the following sequence:

1. Set the bit to enable the desired ADC clock in the PCLKCR13 register.
2. Set the desired ADC clock divider in the PRESCALE field of ADCCTL2.
3. Power up the ADC by setting the ADCPWDNZ bit in ADCCTL1.
4. Allow a delay before sampling. See the data manual for the necessary time.

If multiple ADCs are powered up simultaneously, steps 1 and step 3 can each be done for all ADCs in one write instruction. Also, only one delay is necessary as long as it occurs after all the ADCs have begun powering up.

7.4.2.11 ADC Calibration

During the fabrication and test process, Texas Instruments calibrates the gain, offset, and linearity of the ADCs and the offset of the buffered DACs. These trim settings are embedded into TI reserved OTP memory as part of C-callable functions.

- The Device_cal() function copies the trim values for ADC from OTP memory to their respective trim registers.
- The trim functions in Device_cal() are callable in C2000ware as ADC_setOFFSETTRIM(), ADC_setINLTRIM(). These functions fetch trim values from the TI reserved OTP memory source locations where the values are stored during test process as well as the analog module register destinations where the trim values are copied to.

Until the appropriate factory trim is loaded, the ADC (and other modules) will not be assured to operate within data sheet specifications. Similarly, if trim values other than the factory settings are placed into the trim registers, the ADC (and other modules) will not be assured to operate within data sheet specifications.

The boot ROM will call the calibration functions, so trim values should be initially populated without user intervention. However, if the trims are cleared due to a module reset or modified for some other reason, then the user can call the calibration functions (defined in the header files).

7.4.2.11.1 ADC Zero Offset Calibration

Zero offset error is defined as the difference from 0 that occurs when converting a voltage at VREFLO. The zero offset error can be positive or negative. To correct this error, an adjustment of equal magnitude and opposite polarity is written into the ADCOFFTRIM register. The value contained in this register will be applied before the results are available in the ADC result registers. This operation is fully contained within the ADC core, so the timing of the results will not be affected and the full dynamic range of the ADC will be maintained for any trim value.

Using the `GetAdcOffsetTrimOTP(Uint16)` function, the ADCOFFTRIM register can be loaded with the factory calibrated offset error correction. You can modify the ADCOFFTRIM register to compensate for additional offset error induced by the application environment if desired, but this is not typically necessary to achieve data sheet specified performance.

Note

Regardless of the converter resolution, the size of each ADCOFFTRIM step is $(VREFHI - VREFLO) / 65536$.

Use the following procedure to re-calibrate the ADC offset in 12-bit, single-ended mode:

1. Set ADCOFFTRIM to +112 steps (0x70). This adds an artificial offset to account for negative offset that may reside in the ADC core.
2. Perform some multiple of 16 conversions on VREFLO (internal connection), accumulating the results (for example, $32 * 16$ conversions = 512 conversions).
3. Divide the accumulated result by the multiple of 16 (for example, for 512 conversions, divide by 32).
4. Set ADCOFFTRIM to 112 – result from step 3.

7.4.2.12 ADC Timings

The process of converting an analog voltage to a digital value is broken down into an S+H phase and a conversion phase. The ADC sample and hold circuits (S+H) are clocked by SYSCLK while the ADC conversion process is clocked by ADCCLK. ADCCLK is generated by dividing down SYSCLK based on the PRESCALE field in the ADCCTL2 register.

The S+H duration is the value of the ACQPS field of the SOC being converted, plus one, times the SYSCLK period. The user must ensure that this duration exceeds both 1 ADCCLK period and the minimum S+H duration specified in the data sheet. The conversion time is approximately 11.5 ADCCLK cycles. The exact conversion time is always a whole number of SYSCLK cycles. See the timing diagrams and tables in [Section 7.4.2.12.1](#) for exact timings.

7.4.2.12.1 ADC Timing Diagrams

The following diagrams show the ADC conversion timings for two SOC's given the following assumptions:

- SOC0 and SOC1 are configured to use the same trigger.
- No other SOC's are converting or pending when the trigger occurs.
- The round robin pointer is in a state that causes SOC0 to convert first.
- ADCINTSEL is configured to set an ADCINT flag upon end of conversion for SOC0 (whether this flag propagates through to the CPU to cause an interrupt is determined by the configurations in the PIE module).

[Table 7-106](#) describes the parameters in the following timing diagrams. the ADC timings.

Table 7-106. ADC Timing Parameter Descriptions

Parameter	Description
t_{SH}	<p>The duration of the S+H window.</p> <p>At the end of this window, the value on the S+H capacitor becomes the voltage to be converted into a digital value. The duration is given by $(ACQPS + 1)$ SYSCLK cycles. ACQPS can be configured individually for each SOC, so t_{SH} will not necessarily be the same for different SOC's.</p> <p>Note: The value on the S+H capacitor will be captured approximately 5ns before the end of the S+H window regardless of device clock settings.</p>
t_{LAT}	<p>The time from the end of the S+H window until the ADC results latch in the ADCRESULTx register.</p> <p>If the ADCRESULTx register is read before this time, the previous conversion results will be returned.</p>
t_{EOC}	<p>The time from the end of the S+H window until the S+H window for the next ADC conversion can begin.</p>
t_{INT}	<p>The time from the end of the S+H window until an ADCINT flag is set (if configured).</p> <p>If the INTPULSEPOS bit in the ADCCTL1 register is set, t_{INT} will coincide with the end of conversion (EOC) signal.</p> <p>If the INTPULSEPOS bit is 0, t_{INT} will coincide with the end of the S+H window. If t_{INT} triggers a read of the ADC result register (directly through DMA or indirectly by triggering an ISR that reads the result), care must be taken to ensure the read occurs after the results latch (otherwise, the previous results will be read). To enable precise DMA read timing at the time the ADC result is latched, write 1 to the TDMAEN bit in the ADCCTL1 register.</p>

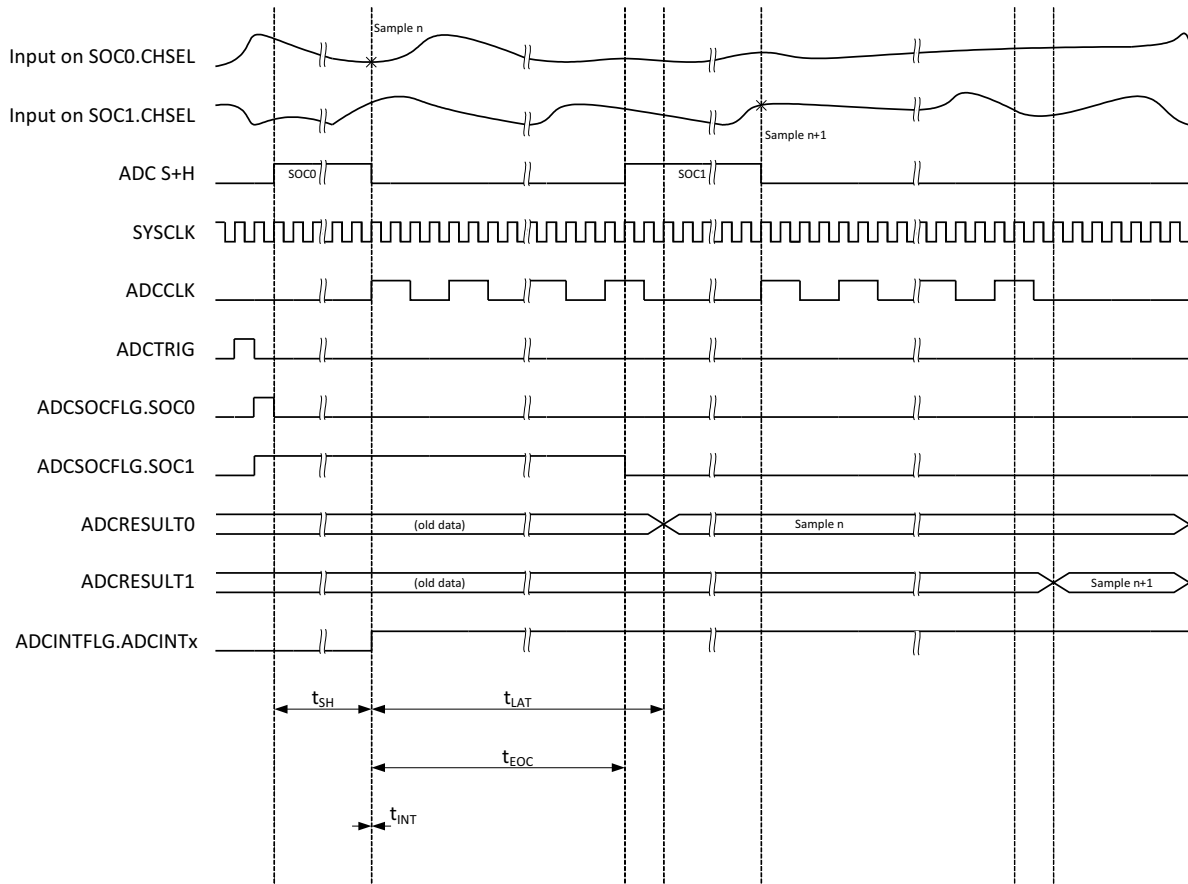

Figure 7-96. ADC Timings for 12-bit Mode in Early Interrupt Mode

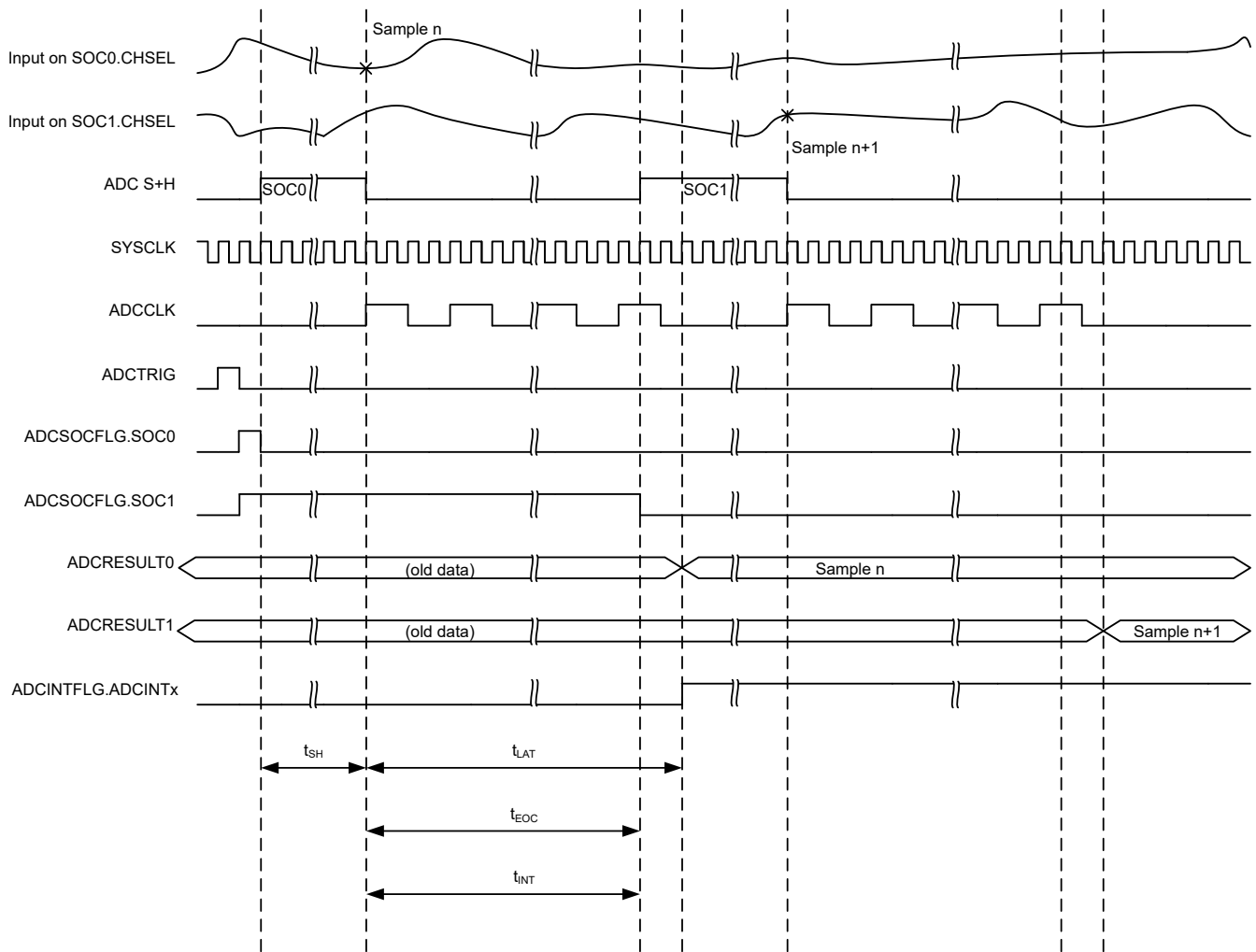

Figure 7-97. ADC Timings for 12-bit Mode in Late Interrupt Mode

7.4.2.13 Additional Information

The following sections contain additional practical information.

7.4.2.13.1 Ensuring Synchronous Operation

For best performance, all ADCs on the device should be operated synchronously. The device datasheet specifies the performance in both synchronous and asynchronous mode for those parameters which differ between the modes of operation.

To ensure synchronous operation, all ADCs on the device should operate in lockstep. This is accomplished by writing configurations to all ADCs that cause the sampling and conversion phases of all ADCs to be exactly aligned. The easiest way to accomplish this is to write identical values to the SOC configurations for each ADC for trigger select and ACQPS (S+H duration).

7.4.2.13.1.1 Basic Synchronous Operation

The following example configures two SOC's each on ADCA and ADCB with identical trigger select and ACQPS values. This will result in synchronous operation between ADCA and ADCB. For devices with more than two ADCs, the same principles can be used to synchronize all the ADCs.

```

Example: Basic Synchronous Operation
AdcaRegs.ADCSOC0CTL.bit.CHSEL = 4; //SOC0 will convert ADCINA4
AdcaRegs.ADCSOC0CTL.bit.ACQPS = 19; //SOC0 will use sample duration of 20 SYSCLK cycles
AdcaRegs.ADCSOC0CTL.bit.TRIGSEL = 10; //SOC0 will begin conversion on ePWM3 SOCB
AdcbRegs.ADCSOC0CTL.bit.CHSEL = 0; //SOC0 will convert ADCINB0
AdcbRegs.ADCSOC0CTL.bit.ACQPS = 19; //SOC0 will use sample duration of 20 SYSCLK cycles
AdcbRegs.ADCSOC0CTL.bit.TRIGSEL = 10; //SOC0 will begin conversion on ePWM3 SOCB

AdcaRegs.ADCSOC1CTL.bit.CHSEL = 4; //SOC1 will convert ADCINA4
AdcaRegs.ADCSOC1CTL.bit.ACQPS = 30; //SOC1 will use sample duration of 31 SYSCLK cycles
AdcaRegs.ADCSOC1CTL.bit.TRIGSEL = 10; //SOC1 will begin conversion on ePWM3 SOCB
AdcbRegs.ADCSOC1CTL.bit.CHSEL = 1; //SOC1 will convert ADCINB1
AdcbRegs.ADCSOC1CTL.bit.ACQPS = 30; //SOC1 will use sample duration of 31 SYSCLK cycles
AdcbRegs.ADCSOC1CTL.bit.TRIGSEL = 10; //SOC1 will begin conversion on ePWM3 SOCB
    
```

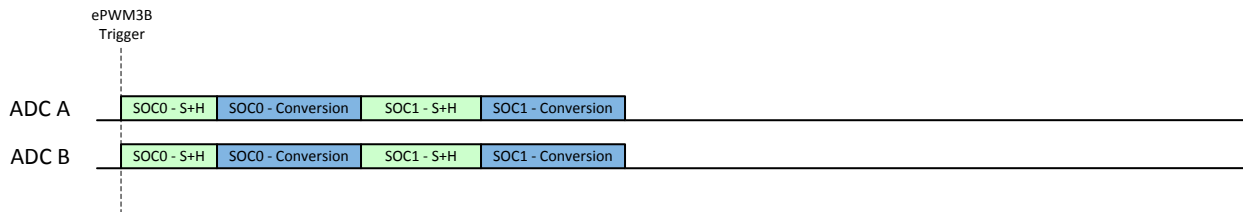

Figure 7-98. Example: Basic Synchronous Operation

Several things should be noted from Figure 7-98. First, while the ACQPS values must be the same for SOC's with the same number, different ACQPS values can be used for SOC's with different numbers. Because of this, synchronous operation does not require a single global S+H time, but instead only channels sampled simultaneously require identical S+H durations. Another important point from this example is that any channel select value can be used for any SOC. Finally, this example assumes round-robin operation. If high priority SOC's are to be used, the priority must be configured the same on all ADCs.

7.4.2.13.1.2 Synchronous Operation with Multiple Trigger Sources

As long as each set of SOCs has identical trigger select and ACQPS settings, multiple trigger sources can be used while still achieving synchronous operation.

The following example demonstrates synchronous operation between ADCA and ADCB while using three SOCs and two trigger sources. [Figure 7-99](#) demonstrates that any combination of relative trigger timings still results in synchronous operation.

Example: Synchronous Operation with Multiple Trigger Sources

```

AdcaRegs.ADCSOC0CTL.bit.CHSEL = 4; //SOC0 will convert ADCINA4
AdcaRegs.ADCSOC0CTL.bit.ACQPS = 19; //SOC0 will use sample duration of 20 SYSCLK cycles
AdcaRegs.ADCSOC0CTL.bit.TRIGSEL = 10; //SOC0 will begin conversion on ePWM3 SOCB
AdcbRegs.ADCSOC0CTL.bit.CHSEL = 0; //SOC0 will convert ADCINB0
AdcbRegs.ADCSOC0CTL.bit.ACQPS = 19; //SOC0 will use sample duration of 20 SYSCLK cycles
AdcbRegs.ADCSOC0CTL.bit.TRIGSEL = 10; //SOC0 will begin conversion on ePWM3 SOCB

AdcaRegs.ADCSOC1CTL.bit.CHSEL = 4; //SOC1 will convert ADCINA4
AdcaRegs.ADCSOC1CTL.bit.ACQPS = 30; //SOC1 will use sample duration of 31 SYSCLK cycles
AdcaRegs.ADCSOC1CTL.bit.TRIGSEL = 10; //SOC1 will begin conversion on ePWM3 SOCB
AdcbRegs.ADCSOC1CTL.bit.CHSEL = 1; //SOC1 will convert ADCINB1
AdcbRegs.ADCSOC1CTL.bit.ACQPS = 30; //SOC1 will use sample duration of 31 SYSCLK cycles
AdcbRegs.ADCSOC1CTL.bit.TRIGSEL = 10; //SOC1 will begin conversion on ePWM3 SOCB

AdcaRegs.ADCSOC2CTL.bit.CHSEL = 0; //SOC2 will convert ADCINA0
AdcaRegs.ADCSOC2CTL.bit.ACQPS = 19; //SOC2 will use sample duration of 20 SYSCLK cycles
AdcaRegs.ADCSOC2CTL.bit.TRIGSEL = 2; //SOC2 will begin conversion on CPU Timer1
AdcbRegs.ADCSOC2CTL.bit.CHSEL = 2; //SOC2 will convert ADCINB2
AdcbRegs.ADCSOC2CTL.bit.ACQPS = 19; //SOC2 will use sample duration of 20 SYSCLK cycles
AdcbRegs.ADCSOC2CTL.bit.TRIGSEL = 2; //SOC2 will begin conversion on CPU Timer1
    
```

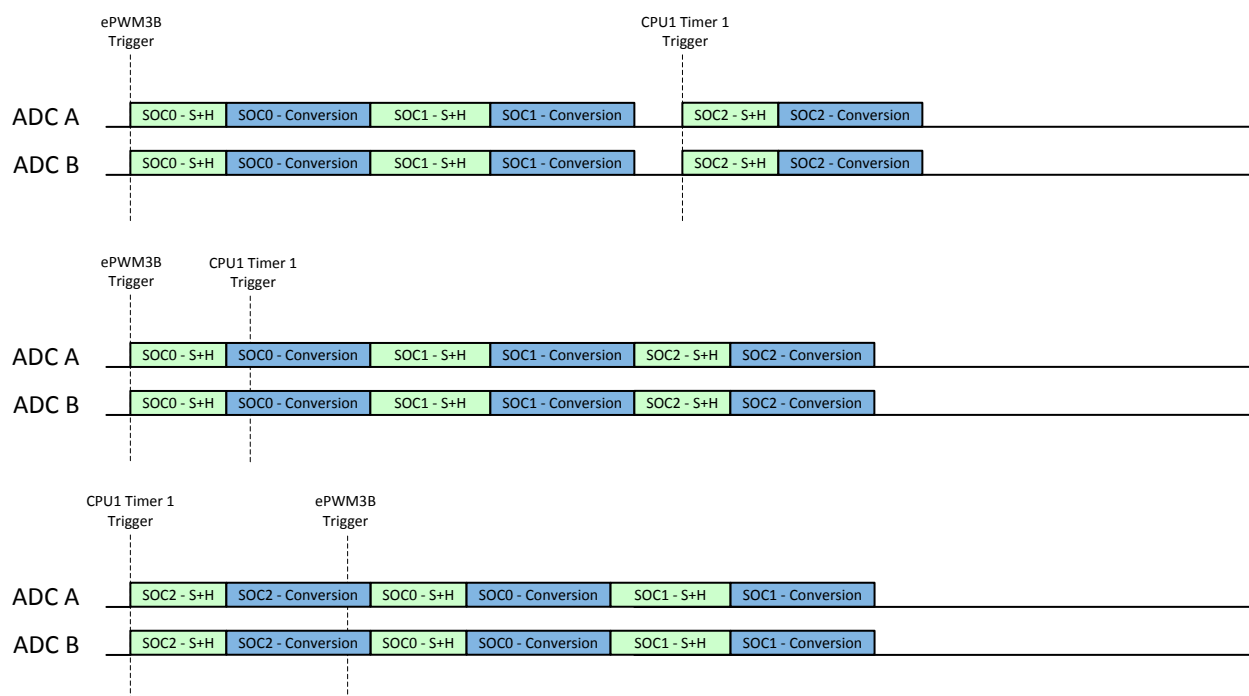

Figure 7-99. Example: Synchronous Operation with Multiple Trigger Sources

Note that any trigger source that can be selected in the TRIGSEL field can be used except for software triggering. There is no way to issue the software triggers for all ADCs simultaneously, so it will likely result in asynchronous operation. ADCINT1 or ADCINT2 can also be used as a trigger as long as the ADCINTSOCSEL1 and ADCINTSOCSEL2 registers are configured identically for all ADCs and software triggering is not used to start the chain of conversions.

7.4.2.13.1.3 Synchronous Operation with Uneven SOC Numbers

If only one trigger source is used, one ADC can use more SOC's than the other ADCs while still operating synchronously.

Example: Synchronous Operation With Uneven SOC Numbers

```

AdcaRegs.ADCSOC0CTL.bit.CHSEL = 4; //SOC0 will convert ADCINA4
AdcaRegs.ADCSOC0CTL.bit.ACQPS = 19; //SOC0 will use sample duration of 20 SYSCLK cycles
AdcaRegs.ADCSOC0CTL.bit.TRIGSEL = 10; //SOC0 will begin conversion on ePWM3 SOCB
AdcbRegs.ADCSOC0CTL.bit.CHSEL = 0; //SOC0 will convert ADCINB0
AdcbRegs.ADCSOC0CTL.bit.ACQPS = 19; //SOC0 will use sample duration of 20 SYSCLK cycles
AdcbRegs.ADCSOC0CTL.bit.TRIGSEL = 10; //SOC0 will begin conversion on ePWM3 SOCB

AdcaRegs.ADCSOC1CTL.bit.CHSEL = 4; //SOC1 will convert ADCINA4
AdcaRegs.ADCSOC1CTL.bit.ACQPS = 30; //SOC1 will use sample duration of 31 SYSCLK cycles
AdcaRegs.ADCSOC1CTL.bit.TRIGSEL = 10; //SOC1 will begin conversion on ePWM3 SOCB
AdcbRegs.ADCSOC1CTL.bit.CHSEL = 1; //SOC1 will convert ADCINB1
AdcbRegs.ADCSOC1CTL.bit.ACQPS = 30; //SOC1 will use sample duration of 31 SYSCLK cycles
AdcbRegs.ADCSOC1CTL.bit.TRIGSEL = 10; //SOC1 will begin conversion on ePWM3 SOCB

AdcaRegs.ADCSOC2CTL.bit.CHSEL = 0; //SOC2 will convert ADCINA0
AdcaRegs.ADCSOC2CTL.bit.ACQPS = 19; //SOC2 will use sample duration of 20 SYSCLK cycles
AdcaRegs.ADCSOC2CTL.bit.TRIGSEL = 10; //SOC2 will begin conversion on ePWM3 SOCB
    
```

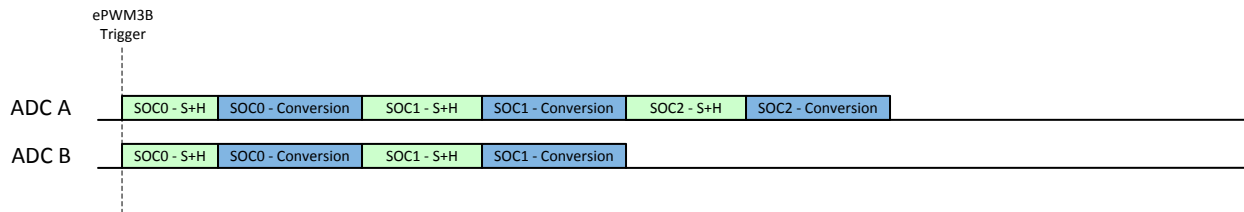

Figure 7-100. Example: Synchronous Operation with Uneven SOC Numbers

Note that if the trigger comes again before all SOC's have completed their conversions, ADCB will begin converting immediately on SOC0 while ADCA will not start converting SOC0 again until SOC2 is complete. This will result in asynchronous operation, so care must be taken to not overflow the trigger.

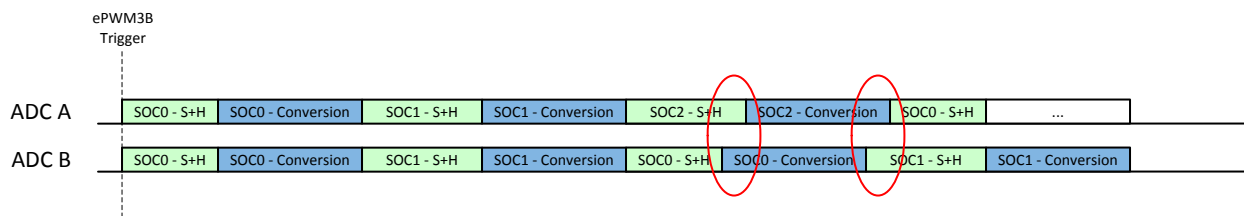

Figure 7-101. Example: Asynchronous Operation with Uneven SOC Numbers – Trigger Overflow

7.4.2.13.1.4 Non-overlapping Conversions

If conversion timings can be guaranteed to not overlap by the user, then it is not necessary to configure all SOC0s identically on all ADCs to achieve performance equivalent to synchronous operation. For example, if the two ADC triggers in a system come from two ePWM sources which are always 180 degrees out-of-phase, then SOC0 could be used for both ADCA and ADCB with different trigger sources and different ACQPS values.

Example: Operation with Non-overlapping Conversions

```
//ePWM3 SOCA and SOCB are 180 degrees out of phase
AdcaRegs.ADCSOC0CTL.bit.CHSEL = 4; //SOC0 will convert ADCINA4
AdcaRegs.ADCSOC0CTL.bit.ACQPS = 19; //SOC0 will use sample duration of 20 SYSCLK cycles
AdcaRegs.ADCSOC0CTL.bit.TRIGSEL = 10; //SOC0 will begin conversion on ePWM3 SOCB
AdcbRegs.ADCSOC0CTL.bit.CHSEL = 0; //SOC0 will convert ADCINB0
AdcbRegs.ADCSOC0CTL.bit.ACQPS = 19; //SOC0 will use sample duration of 20 SYSCLK cycles
AdcbRegs.ADCSOC0CTL.bit.TRIGSEL = 9; //SOC0 will begin conversion on ePWM3 SOCA
```

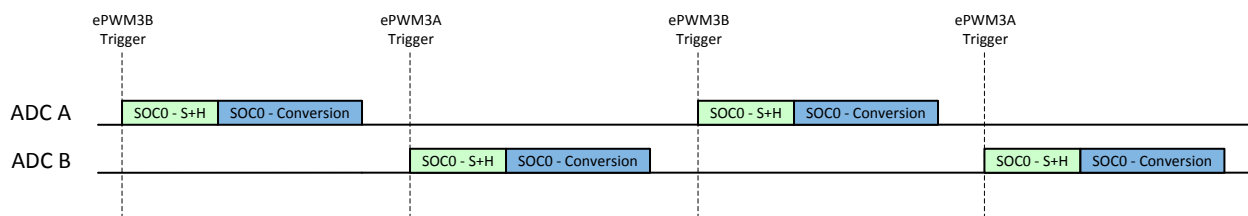

Figure 7-102. Example: Synchronous Equivalent Operation with Non-Overlapping Conversions

7.4.2.13.2 Choosing an Acquisition Window Duration

For correct operation, the input signal to the ADC must be allowed adequate time to charge the sample and hold capacitor, Ch. Typically, the S+H duration is chosen such that the sampling capacitor is charged to within ½ LSB or ¼ LSB of the final value, depending on the tolerable settling error.

The best methodology to determine the required settling time is to simulate the ADC and ADC driving circuits to make sure adequate settling performance. See [ADC Input Circuit Evaluation for C2000 MCUs](#) and [Charge-Sharing Driving Circuits for C2000 ADCs](#) for additional guidance on ADC signal conditioning circuit design and evaluation.

An approximation of the required settling time can also be determined using an RC settling model. The time constant for the model is given by the equation:

$$\tau = (R_s + R_{on}) \cdot C_h + R_s \cdot (C_s + C_p) \quad (4)$$

And the number of time constants needed is given by the equation:

$$k = \ln \left(\frac{2^n}{\text{settling error}} \right) - \ln \left(\frac{C_s + C_p}{C_h} \right) \quad (5)$$

So the total S+H time is set to at least:

$$t = k \cdot \tau \quad (6)$$

Where the following parameters are provided by the ADC input model in the device data sheet:

- n = ADC resolution (in bits)
- R_{ON} = ADC sampling switch resistance (in ohms)
- C_H = ADC sampling capacitor (in pF)
- C_p = ADC channel parasitic input capacitance (in pF)

And the following parameters are dependent on the application design:

- settling error = tolerable settling error (in LSBs)
- R_s = ADC driving circuit source impedance (in ohms)
- C_s = capacitance on ADC input pin (in pF)

For example, assuming the following parameters:

- n = 12-bits
- R_{ON} = 500 Ω
- C_H = 12.5 pF
- C_p = 12.7 pF
- settling error = $\frac{1}{4}$ LSB
- R_s = 180 Ω
- C_s = 150 pF

The time constant is calculated as:

$$\tau = (180\Omega + 500\Omega) \cdot 12.5\text{pF} + 180\Omega \cdot (150\text{pF} + 12.7\text{pF}) = 8.5\text{ns} + 29.3\text{ns} = 37.8\text{ns} \quad (7)$$

And the number of required time constants is:

$$k = \ln\left(\frac{2^{12}}{0.25}\right) - \ln\left(\frac{150\text{pF} + 12.7\text{pF}}{12.5\text{pF}}\right) = 9.70 - 2.57 = 7.13 \quad (8)$$

So the S+H time is set to at least: $37.8\text{ ns} \cdot 7.13 = 270\text{ ns}$

If SYSCLK = 100 MHz, then each SYSCLK cycle is 10 ns. S+H duration is $270\text{ ns}/10\text{ ns} = 27.0$ SYSCLK cycles, so ACQPS for this input is set to at least $\text{CEILING}(27.0) - 1 = 26$.

While this gives a rough estimate of the required acquisition window, a better method is to setup a circuit with the ADC input model, a model of the source impedance/capacitance, and any board parasitics in SPICE (or similar software) and simulate to verify that the sampling capacitor settles to the desired accuracy.

Note

The device data sheet specifies a minimum ADC S+H window duration. Do not use an ACQPS value that gives a duration less than this specification.

7.4.2.13.3 Achieving Simultaneous Sampling

While each ADC does not have dual S+H circuits, it is easy to achieve simultaneous sampling. This is accomplished by setting the SOC triggers on two or more ADC modules to use the same trigger source. The example below demonstrates simultaneous sampling on ADCs based on an ePWM3 event. are sampled. An acquisition window of 20 SYSCLK cycles is used, but different durations are possible.

When the ePWM3 trigger is received, all ADCs will begin converting in parallel immediately. All results will be in the ADCRESULT0 register for each ADC. Note that this assumes that all ADCs are idle when the trigger is received. If one or more ADCs is busy, the samples will not happen at exactly the same time.

7.4.2.13.4 Result Register Mapping

The ADC results and the ADC PPB results are duplicated for each memory bus controller in the system. Bus controllers include all C28x CPUs, C28x DMAs, and CLAs present on the specific part family and part number. For each bus controller, no access configuration is needed to allow read access to the result registers and no contention occurs in cases where multiple bus controllers try to read the ADC results simultaneously.

7.4.2.13.5 Internal Temperature Sensor

The internal temperature sensor measures the junction temperature of the device. The output of the sensor can be sampled with the ADC through an internal connection. This can be enabled on channel by setting the ENABLE bit in the TSNSCTL register.

To convert the temperature sensor reading into a temperature, pass the temperature sensor reading to the function in .

7.4.2.13.6 Designing an External Reference Circuit

[Figure 7-103](#) shows the basic organization of the external voltage reference generation circuitry. The reference voltage should then be buffered by a precision op-amp with good bandwidth and low output impedance before being driven into the reference pin. A capacitor between the high and low reference pins should be placed on the PCB as close to the pins as practical to help absorb high frequency currents. A series resistor (typically <math><1\Omega</math>) in series with this capacitor may be necessary to ensure op-amp stability.

Figure 7-103. ADC Reference System

7.4.3 Comparator Subsystem (CMPSS)

The Comparator Subsystem (CMPSS) consists of analog comparators and supporting circuits that are useful for power applications such as peak current mode control, switched-mode power, power factor correction, voltage trip monitoring, and so forth.

7.4.3.1 Introduction.....	444
7.4.3.2 Comparator.....	446
7.4.3.3 ADC-CMPSS Signal Connections.....	446
7.4.3.4 Reference DAC.....	448
7.4.3.5 Ramp Generator.....	449
7.4.3.6 Digital Filter.....	452
7.4.3.7 Using the CMPSS.....	453

7.4.3.1 Introduction

The comparator subsystem is built around a number of modules. Each subsystem contains two comparators, two reference 12-bit DACs, and two digital filters. Comparators are denoted "H" or "L" within each module where "H" and "L" represent high and low, respectively. Each comparator generates a digital output which indicates whether the voltage on the positive input is greater than the voltage on the negative input. The positive input of the comparator is driven from an external pin. The negative input can be driven by an external pin or by the programmable reference 12-bit DAC for CMPSSA only. Each comparator output passes through a programmable digital filter that can remove spurious trip signals. An unfiltered output is also available if filtering is not required. The negative input for only DACH(CMPSSA) can be driven by an external pin or by programmable 12bit DAC. The negative input for DACL can only be driven by 12-bit DAC. The negative input for CMPSSB can only be driven by the programmable 12-bit DAC. The subsystem also works with the EPWM to support Diode Emulation Mode.

7.4.3.1.1 Features

Each CMPSS includes:

- Two analog comparators
- Two programmable reference 12-bit DACs
- One decrementing ramp generator
- Two digital filters, max filter clock prescale = 2^{16}
- Ability to synchronize submodules with EPWMSYNCPER
- Ability to extend clear signal with EPWMBLANK
- Ability to synchronize output with SYSCLK
- Ability to latch output
- Ability to invert output
- Option to use hysteresis on the input
- Option for negative input of comparator to be driven by an external signal or by the reference DAC
- VDAREF is the DAC reference voltage
- Diode emulation support
- Ramp generator prescaler

7.4.3.1.2 Block Diagram

The block diagram for the CMPSS is shown in Figure 7-104 and Figure 7-105.

- CTRIPx(x= "H" or "L") signals are connected to the ePWM X-BAR for ePWM trip response. See the *Enhanced Pulse Width Modulator (ePWM)* chapter for more details on the ePWM X-BAR mux configuration.
- CTRIPxOUTx(x= "H" or "L") signals are connected to the Output X-BAR for external signaling. See the *General-Purpose Input/Output (GPIO)* chapter for more details on the Output X-BAR mux configuration.

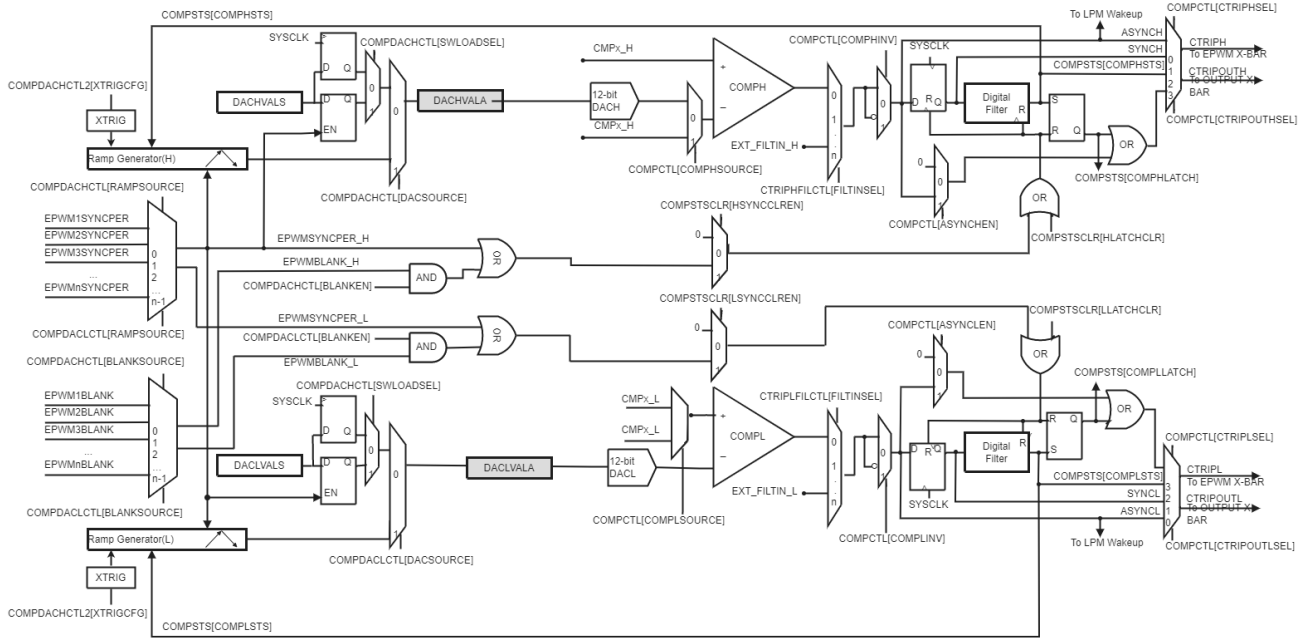

Figure 7-104. CMPSSA Module Block Diagram

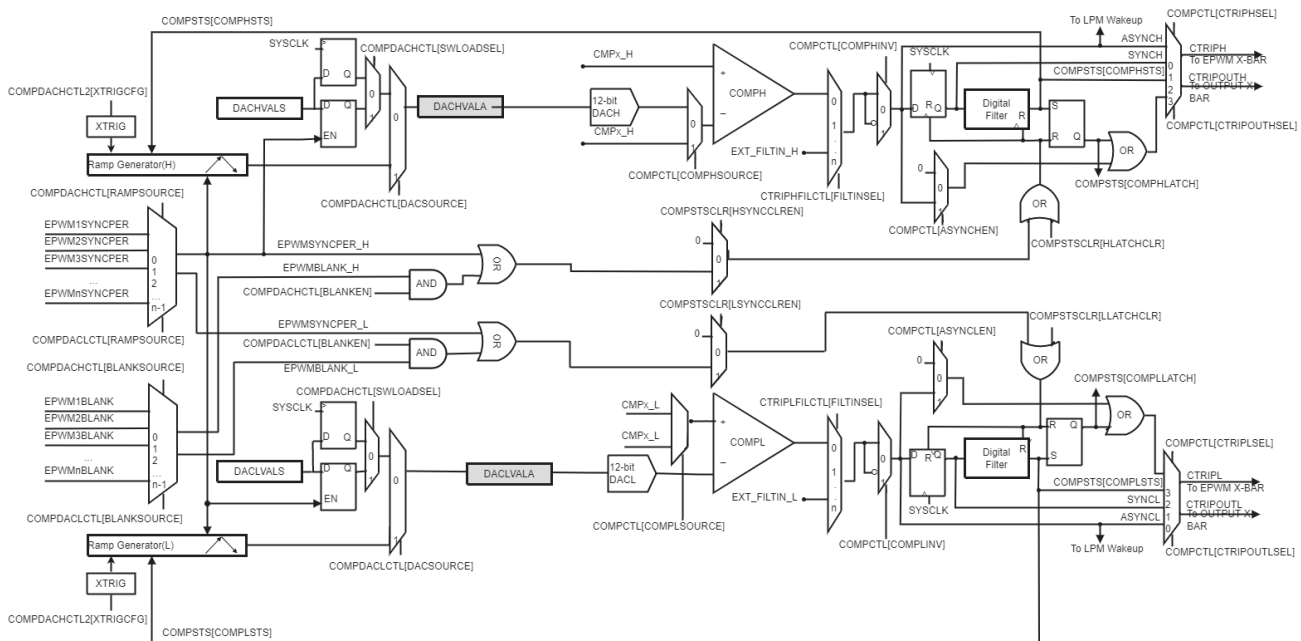

Figure 7-105. CMPSSB Module Block Diagram

ADVANCE INFORMATION

7.4.3.2 Comparator

The comparator generates a high digital output when the voltage on the positive input is greater than the voltage on the negative input, and a low digital output when the voltage on the positive input is less than the voltage on the negative input. The comparator is illustrated in Figure 7-106.

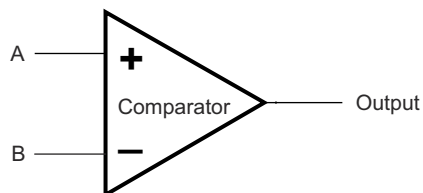

Figure 7-106. Comparator Block Diagram

Voltages	Output
Voltage A > Voltage B	1
Voltage A < Voltage B	0

7.4.3.3 ADC-CMPSS Signal Connections

This table describes the connectivity between the ADC input signals/pins and the associated CMPSS signals.

Signal/Pin Name	ADC Input	CMPSS Input
ADC0_AIN0	ADC0:inp0 (+IN0)	CMPSSA0:inH (+IN)
ADC0_AIN1	ADC0:inm0 (-IN0)	CMPSSA0:inL (-IN)
ADC0_AIN2	ADC0:inp1 (+IN1)	CMPSSA1:inH (+IN)
ADC0_AIN3	ADC0:inm1 (-IN1)	CMPSSA1:inL (-IN)
ADC0_AIN4	ADC0:inp2 (+IN2)	CMPSSB0:inH/inL (+IN/-IN)
ADC0_AIN5	ADC0:inm2 (-IN2)	CMPSSB1:inH/inL (+IN/-IN)
ADC1_AIN0	ADC1:inp0 (+IN0)	CMPSSA2:inH (+IN)
ADC1_AIN1	ADC1:inm0 (-IN0)	CMPSSA2:inL (-IN)
ADC1_AIN2	ADC1:inp1 (+IN1)	CMPSSA3:inH (+IN)
ADC1_AIN3	ADC1:inm1 (-IN1)	CMPSSA3:inL (-IN)
ADC1_AIN4	ADC1:inp2 (+IN2)	CMPSSB2:inH/inL (+IN/-IN)
ADC1_AIN5	ADC1:inm2 (-IN2)	CMPSSB3:inH/inL (+IN/-IN)
ADC2_AIN0	ADC2:inp0 (+IN0)	CMPSSA4:inH (+IN)
ADC2_AIN1	ADC2:inm0 (-IN0)	CMPSSA4:inL (-IN)
ADC2_AIN2	ADC2:inp1 (+IN1)	CMPSSA5:inH (+IN)
ADC2_AIN3	ADC2:inm1 (-IN1)	CMPSSA5:inL (-IN)
ADC2_AIN4	ADC2:inp2 (+IN2)	CMPSSB4:inH/inL (+IN/-IN)
ADC2_AIN5	ADC2:inm2 (-IN2)	CMPSSB5:inH/inL (+IN/-IN)
ADC3_AIN0	ADC3:inp0 (+IN0)	CMPSSA6:inH (+IN)
ADC3_AIN1	ADC3:inm0 (-IN0)	CMPSSA6:inL (-IN)
ADC3_AIN2	ADC3:inp1 (+IN1)	CMPSSA7:inH (+IN)
ADC3_AIN3	ADC3:inm1 (-IN1)	CMPSSA7:inL (-IN)
ADC3_AIN4	ADC3:inp2 (+IN2)	CMPSSB6:inH/inL (+IN/-IN)
ADC3_AIN5	ADC3:inm2 (-IN2)	CMPSSB7:inH/inL (+IN/-IN)
ADC4_AIN0	ADC4:inp0 (+IN0)	CMPSSA8:inH (+IN)
ADC4_AIN1	ADC4:inm0 (-IN0)	CMPSSA8:inL (-IN)
ADC4_AIN2	ADC4:inp1 (+IN1)	CMPSSA9:inH (+IN)
ADC4_AIN3	ADC4:inm1 (-IN1)	CMPSSA9:inL (-IN)
ADC4_AIN4	ADC4:inp2 (+IN2)	CMPSSB8:inH/inL (+IN/-IN)

This table describes the connectivity between the ADC input signals/pins and the associated CMPSS signals.

Signal/Pin Name	ADC Input	CMPSS Input
ADC4_AIN5	ADC4:inm2 (-IN2)	CMPSSB9:inH/inL (+IN/-IN)
ADC_CAL0	ADC(0-4):inp3 (+IN3)	X
ADC_CAL1	ADC(0-4):inm3 (-IN3)	X

7.4.3.4 Reference DAC

Each reference 12-bit DAC can be configured to drive a reference voltage into the negative input of its respective comparator. The reference 12-bit DAC output is internal only and cannot be observed externally.

Two sets of DACxVAL registers, DACxVALA and DACxVALS, are present for each reference 12-bit DAC. DACxVALA is a read-only register that actively controls the reference 12-bit DAC value. DACxVALS is a writable shadow register that loads into DACxVALA either immediately or synchronized with the next EPWMSYNCPER event. The high reference 12-bit DAC (DACH) can optionally source its DACHVALA value from the ramp generator instead of DACHVALS.

The operating range of the reference 12-bit DAC is bounded by DACREF and VSSA. The high voltage reference is VDDA by default, but it can be configured to be VDAC. The reference 12-bit DAC is illustrated in [Figure 7-107](#).

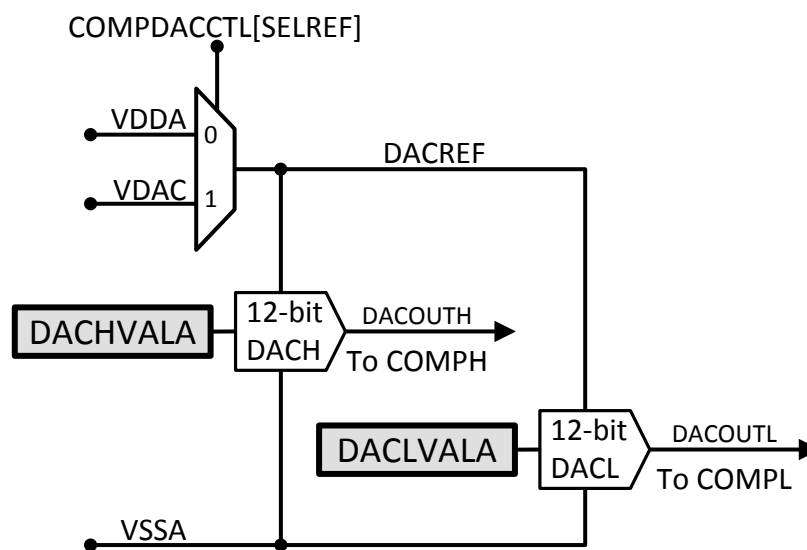

Figure 7-107. Reference DAC Block Diagram

The ideal output of the reference 12-bit DAC can be calculated as:

$$DACOUT = \left(\frac{DACVALA * DACREF}{4096} \right) * \left(\frac{33}{18} \right) \quad (9)$$

Note

The CMPSS instance should be enabled before programming the reference DAC values.

7.4.3.5 Ramp Generator

This section discusses the characteristics of the ramp generator and its behavior.

7.4.3.5.1 Ramp Generator Overview

The ramp generator produces a falling ramp input for the high reference 12-bit DAC when selected. In this mode, the reference 12-bit DAC uses the most significant 12 bits of the RAMPSTS countdown register as its input. The low 4 bits of the RAMPSTS countdown register effectively act as a prescale for the falling ramp rate configurable with `.RAMPxSTEPVALA`. There is an additional dedicated prescaler for the ramp generator configurable with the RAMPCLKDIV register.

The ramp generator is enabled by setting `DACSOURCE = 1`. On setting `DACSOURCE = 1`, the value of RAMPSTS is loaded from RAMPxREFS and the register remains static until the selected EPWMSYNCPER signal is received. After receiving the selected EPWMSYNCPER signal, the value of `.RAMPxSTEPVALA` is subtracted from RAMPSTS on every subsequent SYSCLK cycle.

To prevent the subtraction from commencing a SYSCLK cycle after a EPWMSYNCPER event, the RAMPDLYA register which serves as a delay counter can be used to hold off the RAMPSTS subtraction. On receiving a EPWMSYNCPER event, the value of RAMPDLYA is decremented by one on every SYSCLK cycle until the register reaches zero. The RAMPSTS subtraction will only begin when RAMPDLYA is zero.

7.4.3.5.2 Ramp Generator Behavior

The ramp generator makes state changes on every rising edge of DACSOURCE, EPWMSYNCPER and COMPHSTS.

On the rising edge of DACSOURCE, RAMPMAXREFA, RAMPDECVALA and RAMPDLYA are loaded with their shadow registers. RAMPSTS is loaded with RAMPMAXREFS.

On the rising edge of the selected EPWMSYNCPER, RAMPMAXREFA, RAMPDECVALA and RAMPDLYA are loaded with their shadow registers. RAMPSTS is loaded with RAMPMAXREFS and starts decrementing when RAMPDLYA counter reaches zero.

On the rising edge of COMPHSTS with RAMPLOADSEL = 1, RAMPMAXREFA, RAMPDECVALA and RAMPDLYA are loaded with their shadow registers. RAMPSTS is loaded with RAMPMAXREFS and stops decrementing.

On the rising edge of COMPHSTS with RAMPLOADSEL = 0, RAMPSTS is loaded with RAMPMAXREFA and stops decrementing.

Additionally, if the value of RAMPSTS reaches zero, the RAMPSTS register will remain static at zero until the next EPWMSYNCPER is received. These state changes are illustrated in the ramp generator block diagram in Figure 7-108.

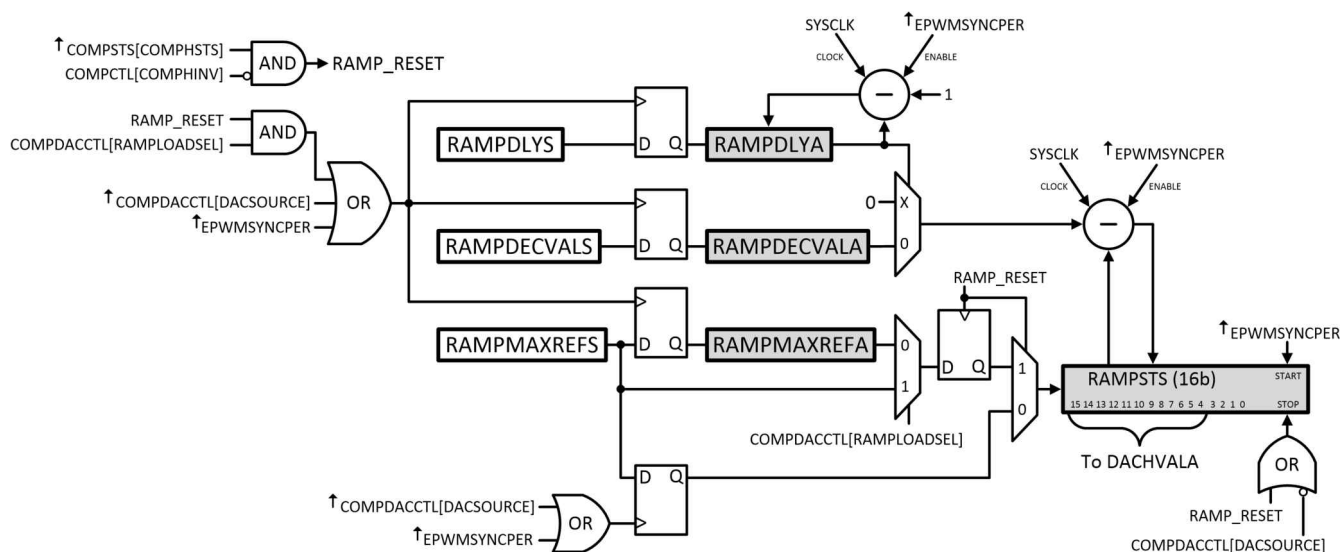

Figure 7-108. Ramp Generator Block Diagram

7.4.3.5.3 Ramp Generator Behavior at Corner Cases

Since the ramp generator makes state changes on every rising edge of EPWMSYNCPER and COMPHSTS, the following behavior can be expected on instances when these two events occur simultaneously or very close together.

Case 1: COMPHSTS rising edge occurs one or more cycles before EPWMSYNCPER rising edge. RAMPSTS stops decrementing on COMPHSTS rising edge event. RAMPSTS starts decrementing on EPWMSYNCPER rising edge event when RAMPDLYA reaches 0.

Case 3: COMPHSTS rising edge occurs one or more cycles after EPWMSYNCPER rising edge but before RAMPDLYA reaches 0. RAMPSTS does not decrement when RAMPDLYA reaches 0.

Case 4: COMPHSTS rising edge occurs simultaneously as RAMPDLYA reaches 0 from EPWMSYNCPER rising edge. RAMPSTS does not decrement.

This behavior is also illustrated in [Figure 7-109](#).

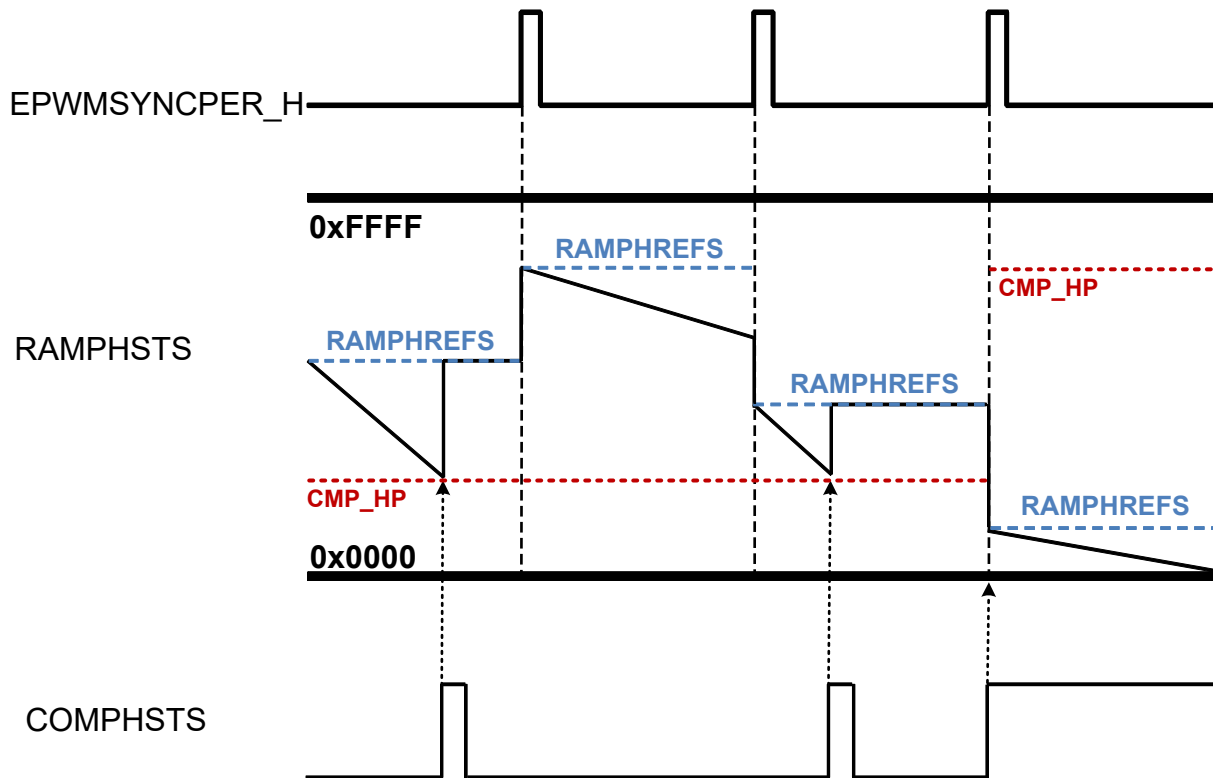

Figure 7-109. Ramp Generator Behavior

7.4.3.6 Digital Filter

The digital filter works on a window of FIFO samples (SAMPWIN) taken from the input. The filter output resolves to the majority value of the sample window, where majority is defined by the threshold (THRESH) value. If the majority threshold is not satisfied, the filter output remains unchanged.

For proper operation, the value of THRESH must be greater than $SAMPWIN / 2$ and less than or equal to SAMPWIN.

A prescale function (CLKPRESCALE) determines the filter sampling rate, where the filter FIFO captures one sample every prescale system clocks. Old data from the FIFO is discarded.

Note that for SAMPWIN, THRESH and CLKPRESCALE, the internal number used by the digital filter is + 1 in all cases. In essence, samples = SAMPWIN + 1, threshold = THRESH + 1 and prescale = CLKPRESCALE + 1.

A conceptual model of the digital filter is shown in [Figure 7-110](#).

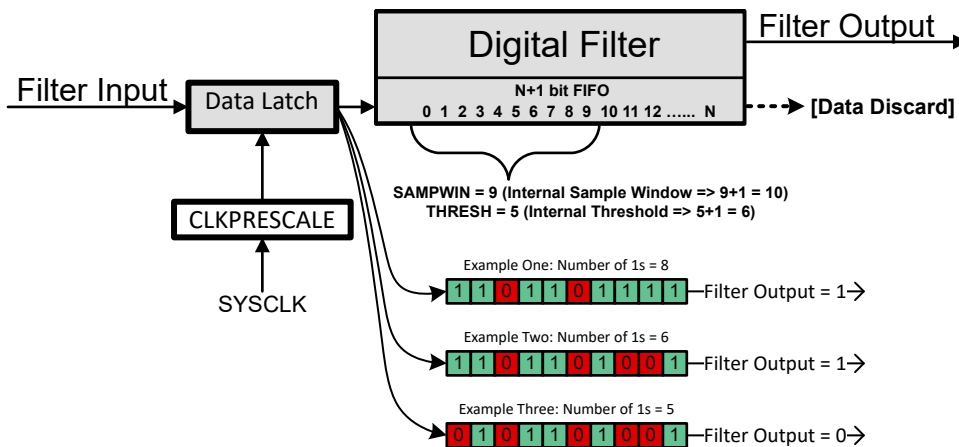

Figure 7-110. Digital Filter Behavior

Equivalent C code of the filter implementation is:

```

if (FILTER_OUTPUT == 0) {
    if (Num_1s_in_SAMPWIN >= THRESH) {
        FILTER_OUTPUT = 1;
    }
} else {
    if (Num_0s_in_SAMPWIN >= THRESH) {
        FILTER_OUTPUT = 0;
    }
}
    
```

7.4.3.6.1 Filter Initialization Sequence

To ensure proper operation of the digital filter, the following initialization sequence is recommended:

1. Configure and enable the comparator for operation.
2. Configure the digital filter parameters for operation:
 - Set SAMPWIN for the number of samples to monitor in the FIFO window.
 - Set THRESH for the threshold required for majority qualification.
 - Set CLKPRESCALE for the digital filter clock prescale value.
3. Initialize the sample values in the digital FIFO window by setting FILINIT.
4. Clear COMPSTS latch via COMPSTSCLR if the latched path is desired.
5. Configure the CTRIP and CTRIPOUT signal paths.
6. If desired, configure the destination module, for example, ePWM, GPIO, and so on to accept the filtered signals.

7.4.3.7 Using the CMPSS

7.4.3.7.1 LATCHCLR, EPWMSYNCPER and EPWMBLANK Signals

The LATCHCLR signal holds the digital filter, synchronization block and the latch output in reset (0) after the required delays. It is activated in software using xLATCHCLR(x= "H" or "L"). It can also be activated by EPWMSYNCPER when xSYNCCLREN(x= "H" or "L") is set. If a longer LATCHCLR signal is required, the EPWMBLANK signal can be used to extend it by setting BLANKEN.

EPWMSYNCPER and EPWMBLANK (BLANKWDW) come from the Time-Base and Digital Compare submodules of the EPWM, respectively. For a detailed description of how these two signals are generated, refer to the respective submodule section in the *Enhanced Pulse Width Modulator (ePWM)* chapter.

The EPWMSYNCPER signal that loads DACxVALA when COMPDACCTL [SWLOADSEL] = 1 is a level trigger load. If TBCTR and TBPRD of the EPWM are both 0, EPWMSYNCPER will be held at level high and DACxVALA will be loaded immediately from DACxVALS irrespective of the value of COMPDACCTL [SWLOADSEL]. Due to this, it is recommended to configure the EPWM first before setting COMPDACCTL [SWLOADSEL] to 1.

Note

The name of the sync signal that the CMPSS receives from the EPWM has been updated from PWMSYNC to EPWMSYNCPER (SYNCPER/PWMSYNCPER/EPWMxSYNCPER) to avoid confusion with the other EPWM sync signals EPWMSYNCI and EPWMSYNCO. For a description of what are these signals, see the *Enhanced Pulse Width Modulator (ePWM)* chapter.

7.4.3.7.2 Synchronizer, Digital Filter and Latch Delays

The synchronization block adds a delay of 1-2 sysclks. If the digital filter is bypassed (all filter settings are 0), the digital filter will add a delay of 2 sysclks. The latch adds 1 sysclk delay.

7.4.3.7.3 Calibrating the CMPSS

The CMPSS has two sources of offset errors: comparator offset error and compdac offset error. In the data manual, the comparator offset error is referred to as **Input referred offset error** and compdac offset error is referred to as **Static offset error**. See the device specific data manual for their values.

If both inputs of the comparator are driven from a pin, only the comparator offset error applies. However if the inverting input of the comparator is driven from the compdac, then only the compdac offset error applies. This is because the compdac offset error includes comparator offset error.

Due to the offset errors, it is recommended that the CMPSS be calibrated to ensure trips happen at the expected levels. The flow below outlines how the calibration can be performed if the inverting input of the comparator is driven from the compdac.

Notes before calibration:

1. A static DC signal is required on the non-inverting input of the comparator.
2. Hysteresis should be disabled for calibration. It can be re-enabled after calibration is complete.
3. A noisy input can make calibration difficult so it is recommended to use the latch with non-zero filter settings depending on how noisy the signal on the non-inverting input is.

This approach sweeps down the compdac:

1. Set the starting compdac value to max, 0xFFFF.
 - Optional: Instead of setting the starting compdac value to max, it can be set to **Vtarget + Static offset error + Margin**. Where **Vtarget** is the approximate DC voltage on the non-inverting input, **Static offset error** is the compdac offset error specification and **Margin** is some amount of guard band. This can lead to a faster calibration but will only work if **Vtarget** is known. Alternatively if **Vtarget** is unknown, the ADC can be used to convert it.
2. Decrement compdac value by 1.
3. Wait for compdac to settle.
4. Clear latch.
5. Wait for possible latch set.
6. If latch is set, trip code is found exit.
 - Optional: The trip code can be double checked by:
 - a. Increasing compdac value by 1.
 - b. Clear latch.
 - c. Wait for possible latch set.
 - d. Latch should be unset.
7. If latch is unset, go back to step 2 and repeat.

It is also possible to calibrate the CMPSS if both inputs of the comparator are driven from a pin. For this case, the flow stays the same but the voltage on the inverting pin of the comparator is swept externally.

7.4.3.7.4 Enabling and Disabling the CMPSS Clock

If the clock to the CMPSS module is disabled while the comparator is active, the following behavior can be expected:

- The comparator remains unaffected and will continue to trip from voltages on its inputs.
- If the reference 12-bit DAC is driving the negative input of the comparator, the voltage on the negative input remains static and unaffected but DACVALA would no longer be updated from the ramp generator or DACVALS.
- The ramp generator, synchronize block and digital filter freeze on their current states.

Enabling the clock to the CMPSS restores it to the state before the clock was disabled.

7.4.4 Buffered Digital-to-Analog Converter (DAC)

The buffered digital-to-analog converter (DAC) is an analog module that can output a programmable, arbitrary reference voltage.

7.4.4.1 Introduction.....	456
7.4.4.2 DAC Integration.....	458
7.4.4.3 Using the DAC.....	458
7.4.4.4 Lock Registers.....	459

7.4.4.1 Introduction

The buffered DAC module consists of an internal 12-bit DAC and an analog output buffer that is capable of driving an external load. For driving even higher loads than typical, a trade-off can be made between load size and output voltage swing. For the load conditions of the buffered DAC, see the device-specific data manual. The buffered DAC is a general-purpose DAC that can be used to generate a DC voltage in addition to AC waveforms such as sine waves, square waves, triangle waves and so forth. Software writes to the DAC value register can take effect immediately or can be synchronized with EPWMSYNCPER events.

7.4.4.1.1 Features

Each buffered DAC has the following features:

- 12-bit programmable internal DAC
- Selectable reference voltage source
- x1 and x2 gain modes when using internal VREFHI
- Pull-down resistor on output
- Ability to synchronize with EPWMSYNCPER

7.4.4.1.2 Block Diagram

The block diagram for the buffered DAC is shown in Figure 7-111.

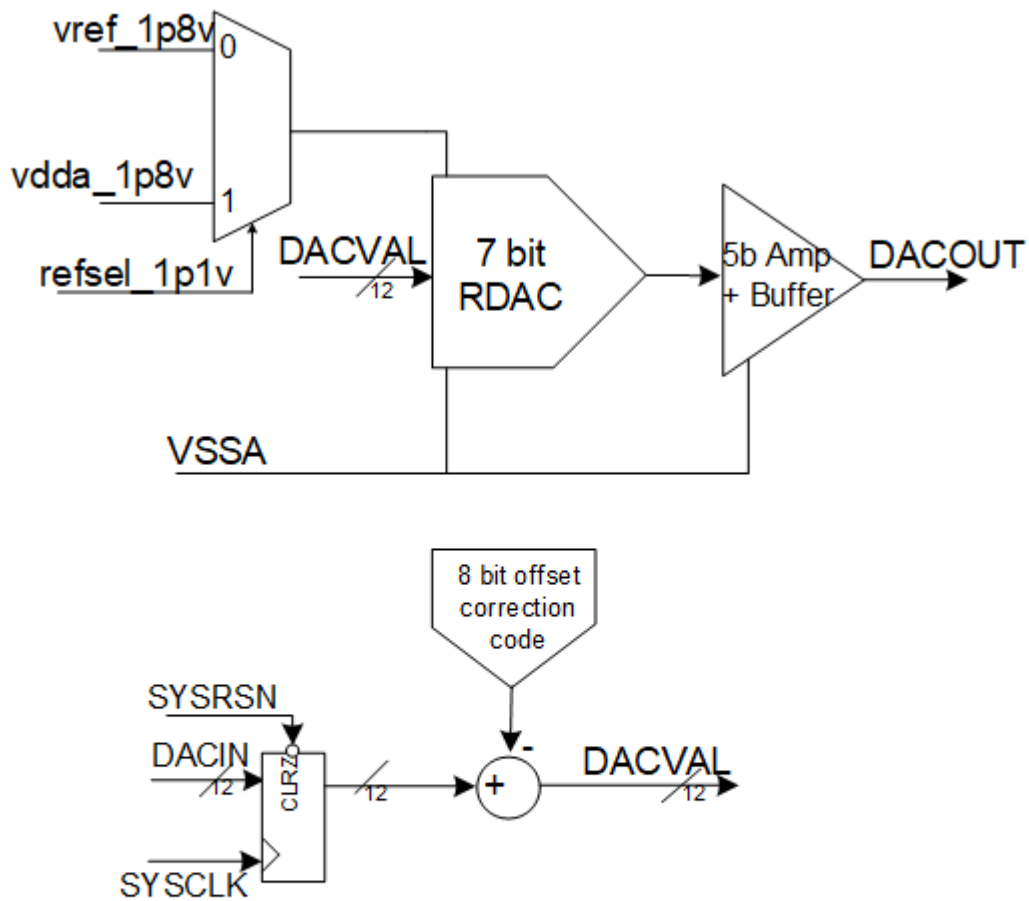

ADVANCE INFORMATION

Figure 7-111. DAC Module Block Diagram

7.4.4.2 DAC Integration

There is 1x DAC module integrated in the device. The diagram below provides a visual representation of the device integration details.

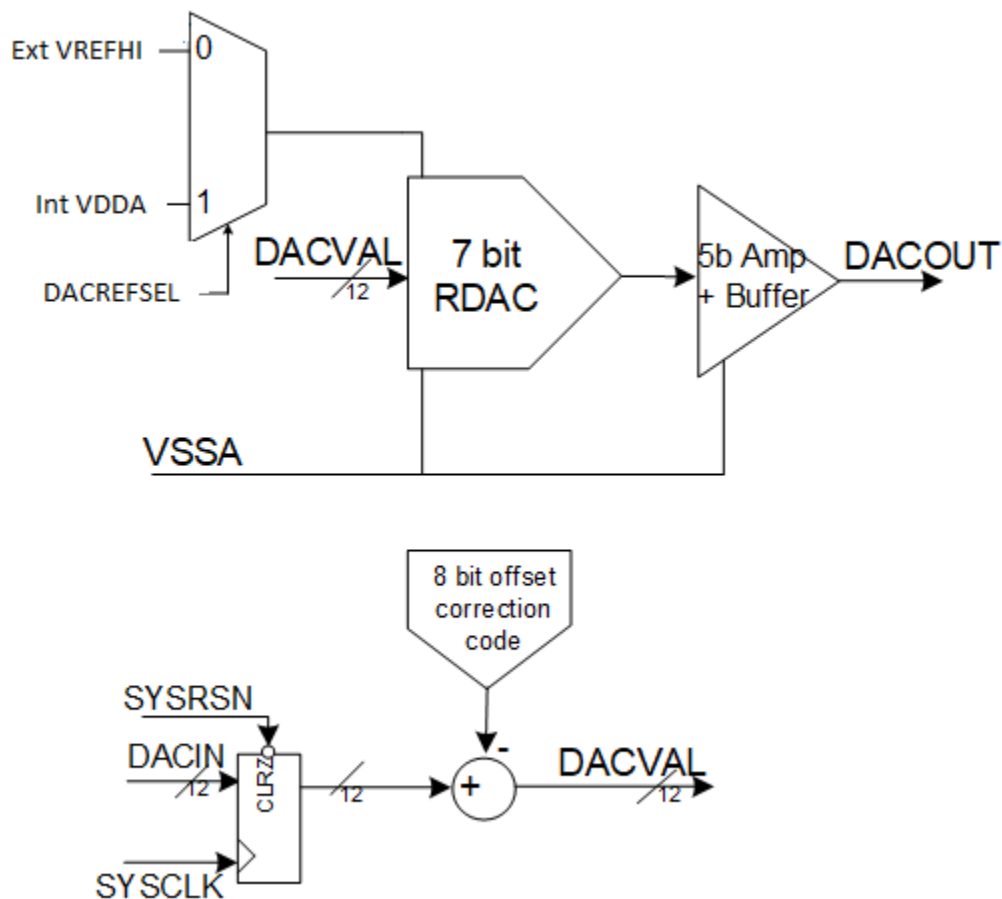

Figure 7-112. DAC Integration Diagram

7.4.4.3 Using the DAC

The internal DAC's reference voltage source, DACREF, is selectable between VDACC and VREFHI.

Two sets of DACVAL registers, DACVALA and DACVALS, are present in the buffered DAC module. DACVALA is a read-only register that actively controls the buffered DAC value. DACVALS is a writable shadow register that loads into DACVALA either immediately or synchronized with the next EPWMSYNCPER event. If the clock to the buffered DAC is disabled while the buffered DAC is outputting a voltage, the output voltage remains unaffected, but DACVALA and DACVALS will no longer be updated with register writes. Enabling the clock to the buffered DAC restores it to the state before the clock was disabled.

The ideal output of the internal DAC is calculated with the following equation:

(10)

$$DACOUT = \left(\frac{DACVALA}{4096} \right) * DACREF * \left(\frac{33}{18} \right)$$

The output buffer of the buffered DAC may exhibit non-linear behavior near the supply rails (VDDA/VSSA). To determine the linear range of the buffered DAC, see the device-specific data manual.

7.4.4.3.1 Initialization Sequence

1. Enable the buffered DAC clock.
2. Set DACREF with DACREFSEL.
3. Power up the buffered DAC with DACOUTEN.
4. Wait for the power-up time to elapse before outputting a voltage. To determine the power-up time of the buffered DAC, see the device-specific data sheet.
5. For predictable behavior of the buffered DAC, two consecutive writes to DACVALS can not be spaced 1024 values apart to allow for the settling time of the buffered DAC

7.4.4.3.2 DAC Offset Adjustment

Zero offset error is defined as the difference between the voltage at midcode (2048) and 1.25v (for 2.5v reference voltage). DAC offset error is calibrated at 2.5v reference voltage and loaded into the DAC offset trim register as part of the Device_cal() function. If the DAC is used at any reference voltage other than 2.5v, the offset trim must be adjusted to ensure the offset error performance stays within the device-specific data manual limits. The DAC offset register is a 16-bit register that contains the 8-bit signed offset trim in the lower half of the register. Use the function call DAC_tuneOffsetTrim() found in C2000Ware to adjust the offset.

7.4.4.3.3 EPWMSYNCPER Signal

EPWMSYNCPER comes from the Time-Base submodule of the EPWM. For a detailed description of how this signal is generated, refer to the Time-Base Submodule section of the *Enhanced Pulse Width Modulator (ePWM)* chapter.

The EPWMSYNCPER signal that loads DACVALA when DACCTL [LOADMODE] = 1 is a level trigger load. If TBCTR and TBPRD of the EPWM are both 0, EPWMSYNCPER will be held at level high and DACVALA will be loaded immediately from DACVALS irrespective of the value of DACCTL [LOADMODE]. Due to this, it is recommended to configure the EPWM first before setting DACCTL [LOADMODE] to 1.

Note

The name of the sync signal that the GPDAC receives from the EPWM has been updated from PWMSYNC to EPWMSYNCPER (SYNCPER/PWMSYNCPER/EPWMxSYNCPER) to avoid confusion with the other EPWM sync signals EPWMSYNCL and EPWMSYNCO. For a description of what are these signals, see the *Enhanced Pulse Width Modulator (ePWM)* chapter.

7.4.4.4 Lock Registers

A DACLOCK register is provided to prevent spurious writes from modifying the DACCTL, DACVALS, and DACOUTEN registers. Once a register is protected through DACLOCK, write access will be locked out until the device is reset.

7.4.5 Enhanced Pulse Width Modulator (ePWM)

The enhanced pulse width modulator (ePWM) peripheral is a key element in controlling many of the power electronic systems found in both commercial and industrial equipment. These systems include digital motor control, switch mode power supply control, uninterruptible power supplies (UPS), and other forms of power conversion. The ePWM peripheral can also perform a digital to analog (DAC) function, where the duty cycle is equivalent to a DAC analog value; it is sometimes referred to as a power DAC.

This chapter is applicable for ePWM type 5. Type 5 EPWM is fully compatible with type 4 EPWM.

Further information can be found in the [Flexible PWMs Enable Multi-Axis Drives, Multi-Level Inverters Technical Brief](#).

7.4.5.1 Introduction.....	461
7.4.5.2 EPWM Integration.....	466
7.4.5.3 Configuring Device Pins.....	468
7.4.5.4 ePWM Modules Overview.....	468
7.4.5.5 Time-Base (TB) Submodule.....	470
7.4.5.6 Counter-Compare (CC) Submodule.....	486
7.4.5.7 Action-Qualifier (AQ) Submodule.....	492
7.4.5.8 Dead-Band Generator (DB) Submodule.....	507
7.4.5.9 PWM Chopper (PC) Submodule.....	514
7.4.5.10 Trip-Zone (TZ) Submodule.....	518
7.4.5.11 Event-Trigger (ET) Submodule.....	524
7.4.5.12 Digital Compare (DC) Submodule.....	529
7.4.5.13 PWMXBAR.....	533
7.4.5.14 Applications to Power Topologies.....	534
7.4.5.15 Register Lock Protection.....	552
7.4.5.16 High-Resolution Pulse Width Modulator (HRPWM).....	553

7.4.5.1 Introduction

This chapter includes an overview and information about each submodule:

- Time-Base Submodule
- Counter Compare Submodule
- Action Qualifier Submodule
- Dead-Band Generator Submodule
- PWM Chopper (PC) Submodule
- Trip Zone Submodule
- Event Trigger Submodule
- Digital Compare Submodule

The ePWM Type 4 is functionally compatible to Type 2 (a Type 3 does not exist). Type 4 has the following enhancements in addition to the Type 2 features:

- **Register Address Map**

Additional registers are required for new features on ePWM Type 4. The ePWM register address space has been remapped for better alignment and easy usage.

- **Delayed Trip Functionality**

Changes have been added to achieve deadband insertion capabilities to support, for example, delayed trip functionality needed for peak current mode control type application scenarios. This has been accomplished by allowing comparator events to go into the Action Qualifier as a trigger event (Events T1 and T2). If comparator T1 / T2 events are used to edit the PWM, changes to the PWM waveform will not take place immediately. Instead, they will synchronize to the next TBCLK.

- **Dead-Band Generator Submodule Enhancements**

Shadowing of the DBCTL register to allow dynamic configuration changes.

- **One Shot and Global Load of Registers**

The ePWM Type 4 allows one shot and global load capability from shadow to active registers to avoid partial loads in, for example, multiphase applications. It also allows a programmable prescale of shadow to active load events. ePWM Type 4 Global Load can simplify ePWM software by removing interrupts and ensuring that all registers are loaded at the same time.

- **Trip Zone Submodule Enhancements**

Independent flags have been added to reflect the trip status for each of the TZ sources. Changes have been made to the trip zone submodule to support certain power converter switching techniques like valley switching.

- **Digital Compare Submodule Enhancements**

Blanking window filter register width has been increased from 8 to 16 bits. DCCAP functionality has been enhanced to provide more programmability.

- **PWM SYNC Related Enhancements**

The ePWM Type 4 allows PWM SYNCOUT generation based on CMPC and CMPD events. These events can also be used for PWMSYNC pulse selection.

The ePWM Type 2 is fully compatible to Type 1. Type 2 has the following enhancements in addition to the Type 1 features:

- **High Resolution Dead-Band Capability**

High resolution capability is added to dead-band RED and FED in half-cycle clocking mode.

- **Dead-Band Generator Submodule Enhancements**

The ePWM Type 2 has features to enable both RED and FED on either PWM outputs. Provides increased dead band with 14-bit counters and dead-band / dead-band high-resolution registers are shadowed

- **High Resolution Extension available on ePWMxB outputs**

Provides the ability to enable high-resolution period and duty cycle control on ePWMxB outputs. This is discussed in more detail in [Section 7.4.5.16](#).

- **Counter Compare Submodule Enhancements**

The ePWM Type 2 allows Interrupts and SOC events to be generated by additional counter compares CMPC and CMPD.

- **Event Trigger Submodule Enhancements**

Prescaling logic to issue interrupt requests and ADC start of conversion expanded up to every 15 events. It allows software initialization of event counters on SYNC event.

- **Digital Compare Submodule Enhancements**

Digital Compare Trip Select logic [DCTRIPSEL] has up to 12 external trip sources selected by the Input X-BAR logic in addition to an ability to OR all of them (up to 14 [external and internal sources]) to create the respective DCxEVTs.

- **Simultaneous Writes to TBPRD and CMPx Registers**

This feature allows writes to TBPRD, CMPA:CMPAHR, CMPB:CMPBHR, CMPC and CMPD of any ePWM module to be tied to any other ePWM module, and also allows all ePWM modules to be tied to a particular ePWM module if desired.

- **Shadow to Active Load on SYNC of TBPRD and CMP Registers**

This feature supports simultaneous writes of TBPRD and CMPA/B/C/D registers.

An effective PWM peripheral must be able to generate complex pulse width waveforms with minimal CPU overhead or intervention. It must be highly programmable and very flexible while being easy to understand and use. The ePWM unit described here addresses these requirements by allocating all needed timing and control resources on a per PWM channel basis. Cross coupling or sharing of resources has been avoided; instead, the ePWM is built up from smaller single channel submodules with separate resources that can operate together as required to form a system. This modular approach results in an orthogonal architecture and provides a more transparent view of the peripheral structure, helping users to understand its operation quickly.

In this document, the letter x within a signal or submodule name is used to indicate a generic ePWM instance on a device. For example, output signals EPWMxA and EPWMxB refer to the output signals from the ePWMx instance. Thus, EPWM1A and EPWM1B belong to ePWM1 and likewise EPWM4A and EPWM4B belong to ePWM4.

Type0 to Type1 Enhancements

- **Increased Dead-Band Resolution**

Dead-band clocking has been enhanced to allow half-cycle clocking to double resolution.

- **Enhanced Interrupt and SOC Generation**

Interrupts and ADC start-of-conversion can now be generated on both the TBCTR == zero and TBCTR == period events. This feature enables dual edge PWM control. Additionally, the ADC start-of-conversion can be generated from an event defined in the digital compare submodule.

- **High Resolution Period Capability**

Provides the ability to enable high-resolution period. This is discussed in more detail in the device-specific *High-Resolution Pulse Width Modulator (HRPWM)* document..

- **Digital Compare Submodule**

The digital compare submodule enhances the event triggering and trip zone submodules by providing filtering, blanking and improved trip functionality to digital compare signals. Such features are essential for peak current mode control and for support of analog comparators.

Note

The name of the sync signal that goes to the CMPSS has been updated from PWMSYNC to EPWMSYNCPER (SYNCPER/PWMSYNCPER/EPWMxSYNCPER) to avoid confusion with the other EPWM sync signals EPWMSYNCI and EPWMSYNCO. For a description of these signals, see [Table 7-108](#).

7.4.5.1.1 Submodule Overview

The ePWM module represents one complete PWM channel composed of two PWM outputs: EPWMxA and EPWMxB. Multiple ePWM modules are instanced within a device as shown in [Section 4.4](#). Each ePWM instance is identical with one exception. Some instances include a hardware extension that allows more precise control of the PWM outputs. This extension is the high-resolution pulse width modulator (HRPWM) and is described in [Section 7.4.5.16](#). See the device-specific data manual to determine which ePWM instances include this feature. Each ePWM module is indicated by a numerical value starting with 1. For example, ePWM1 is the first instance and ePWM3 is the third instance in the system and ePWMx indicates any instance.

The ePWM modules are chained together by way of a clock synchronization scheme that allows them to operate as a single system when required. Additionally, this synchronization scheme can be extended to the capture peripheral submodules (eCAP). The number of submodules is device-dependent and based on target application needs. Submodules can also operate standalone.

Each ePWM module supports the following features:

- Dedicated 16-bit time-base counter with period and frequency control
- Two PWM outputs (EPWMxA and EPWMxB) that can be used in the following configurations:
 - Two independent PWM outputs with single-edge operation
 - Two independent PWM outputs with dual-edge symmetric operation
 - One independent PWM output with dual-edge asymmetric operation
- Asynchronous override control of PWM signals through software.
- Programmable phase-control support for lag or lead operation relative to other ePWM modules.
- Hardware-locked (synchronized) phase relationship on a cycle-by-cycle basis.
- Dead-band generation with independent rising and falling edge delay control.
- Programmable trip zone allocation of both cycle-by-cycle trip and one-shot trip on fault conditions.
- A trip condition can force either high, low, or high-impedance state logic levels at PWM outputs.
- All events can trigger both CPU interrupts and ADC start of conversion (SOC)
- Programmable event prescaling minimizes CPU overhead on interrupts.
- PWM chopping by high-frequency carrier signal, useful for pulse transformer gate drives.

Each ePWM module is connected to the input/output signals shown in [#unique_641/unique_641_Connect_42_FIG_CDH_MYT_VSB_263referenceTitle](#). The signals are described in detail in subsequent sections.

The order in which the ePWM modules are connected can differ from what is shown in [#unique_641/unique_641_Connect_42_FIG_CDH_MYT_VSB_263referenceTitle](#). See [Section 7.4.5.3.3](#) for the synchronization scheme for a particular device. Each ePWM module consists of eight submodules and is connected within a system by way of the signals shown in [Figure 7-113](#).

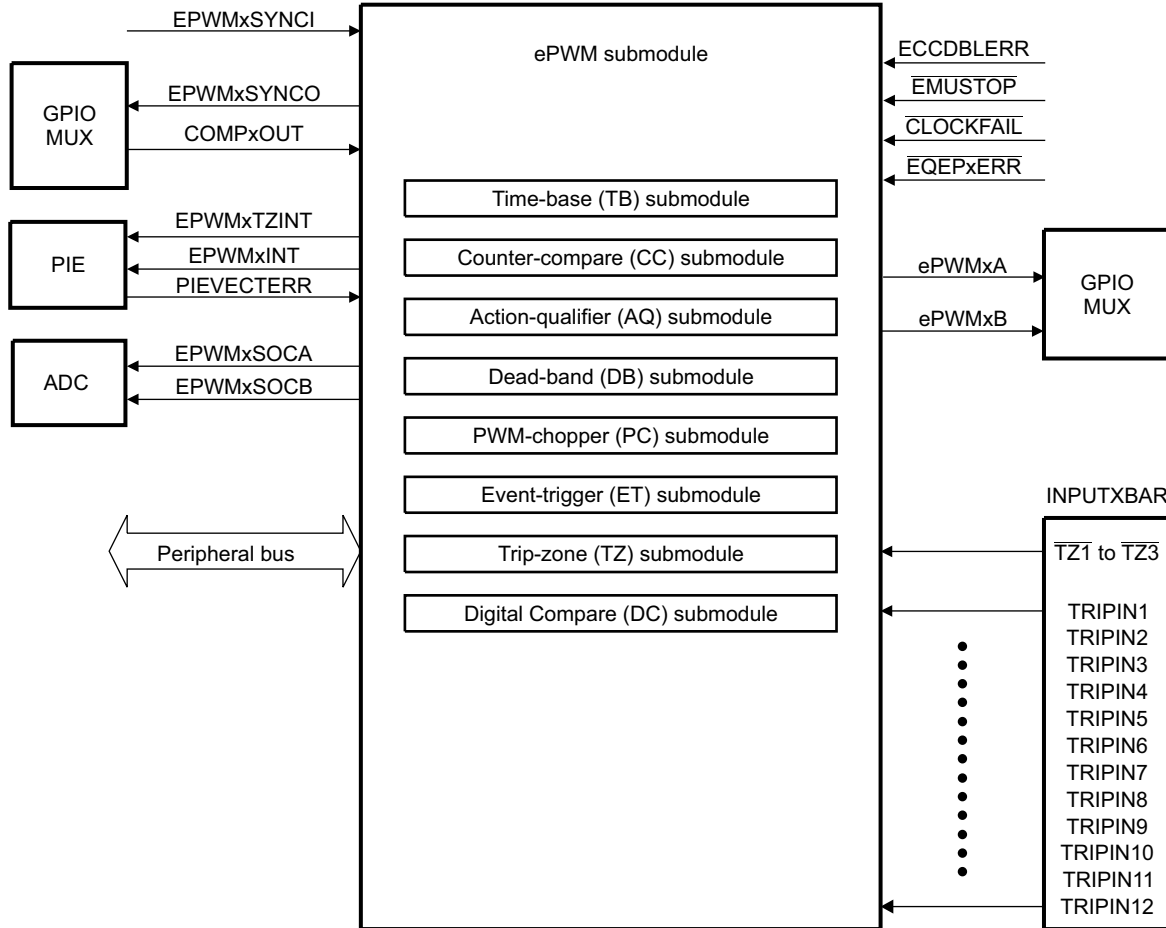

Figure 7-113. Submodules and Signal Connections for an ePWM Module

ADVANCE INFORMATION

shows more internal details of a single ePWM module. The main signals used by the ePWM module are:

- **PWM output signals (EPWMxA and EPWMxB)**

The PWM output signals are made available external to the device.

- **Trip-zone signals (TZ1 to TZ6)**

These input signals alert the ePWM module of fault conditions external to the ePWM module. Each submodule on a device can be configured to either use or ignore any of the trip-zone signals. The TZ1 to TZ3 trip-zone signals can be configured as asynchronous inputs through the GPIO peripheral using the Input X-BAR logic, refer to [#unique_643/unique_643_Connect_42_SPRUH225979referenceTitle](#). TZ4 is connected to an inverted EQEPx error signal (EQEPxERR), which can be generated from any one of the EQEP submodule (for those devices with an EQEP module). TZ5 is connected to the system clock fail logic, and TZ6 is connected to the EMUSTOP output from the CPU. This allows you to configure a trip action when the clock fails or the CPU halts.

- **Time-base synchronization input (EPWMxSYNCI), output (EPWMxSYNCO), and peripheral (EPWMxSYNCPER) signals**

For more information, see [Section 7.4.5.5.3.3](#).

Each ePWM module also generates another PWMSYNC signal called EPWMxSYNCPER. EPWMxSYNCPER goes to the CMPSS for synchronization purposes. Functionality is configured using the HRPCTL register but has no relation with the HRPWM. For more information on how EPWMxSYNCPER is used by the CMPSS, see their respective chapters.

- **ADC start-of-conversion signals (EPWMxSOCA and EPWMxSOCB)**

Each ePWM module has two ADC start of conversion signals. Any ePWM module can trigger a start of conversion. Whichever event triggers the start of conversion is configured in the event-trigger submodule of the ePWM.

- **Comparator output signals (COMPxOUT)**

Output signals from the comparator module can be fed through the Input X-BAR to one or all of the 12 trip inputs [TRIPIN1 - TRIPIN12] and in conjunction with the trip zone signals can generate digital compare events.

- **Peripheral bus**

The peripheral bus is 32-bits wide and allows both 16-bit and 32-bit writes to the ePWM register file.

7.4.5.2 EPWM Integration

There are 32x EPWM modules integrated in the device. The diagram below provides a visual representation of the device integration details.

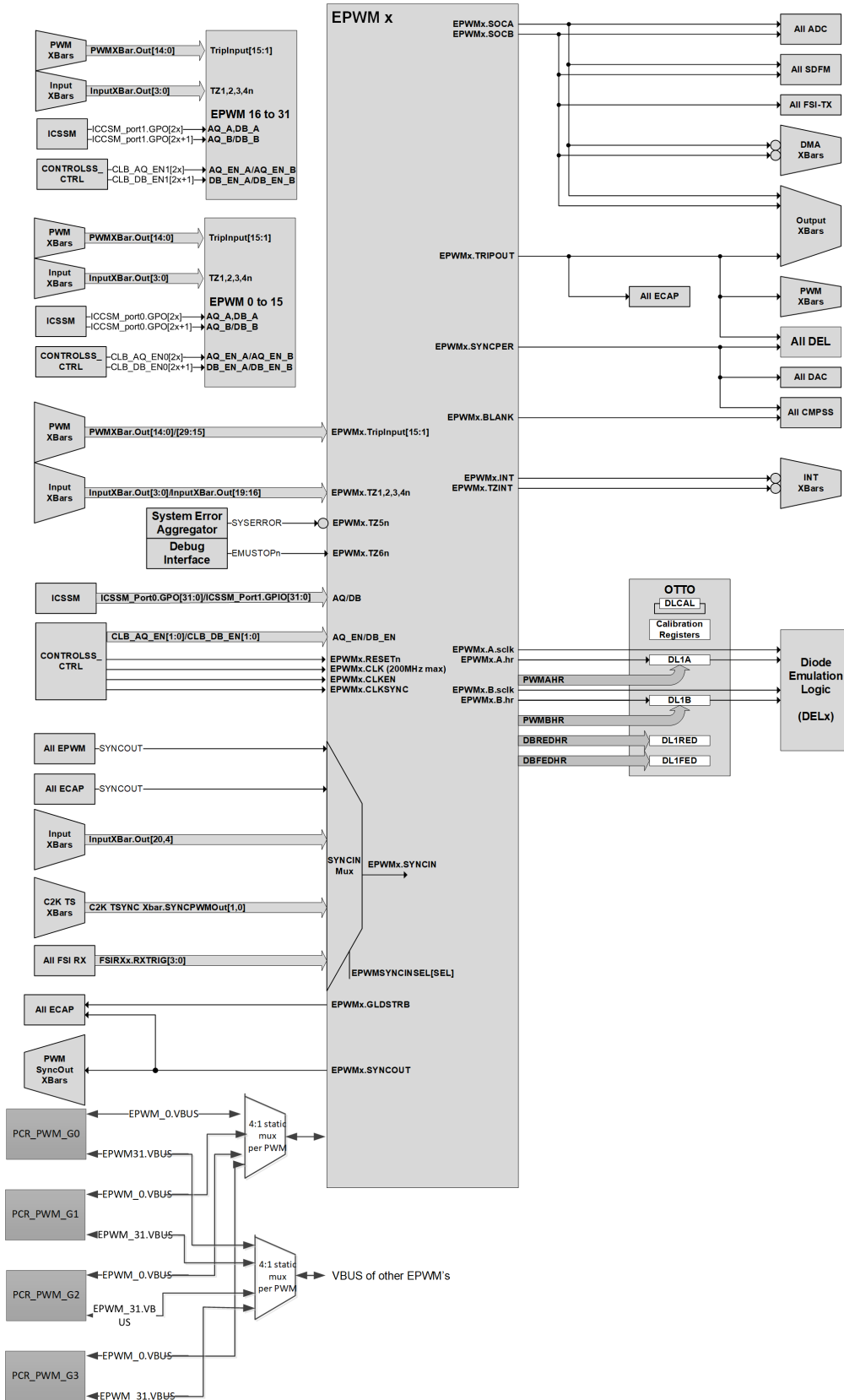

ADVANCE INFORMATION

Figure 7-114. EPWM Integration Diagram

7.4.5.3 Configuring Device Pins

To connect the device input pins to the module, the Input X-BAR must be used. Some examples of when an external signal may be needed are TZx, TRIPx, and EXTSYNCRIN. Any GPIO on the device can be configured as an input. The GPIO input qualification should be set to asynchronous mode by setting the appropriate GPxQSEL register bits to 11b. The internal pullups can be configured in the GPyPUD register. Since the GPIO mode is used, the GPyINV register can invert the signals. Additionally, some TRIPx (TRIP4-12 excluding TRIP6) signals must be routed through the ePWM X-Bar in addition to the Input X-Bar.

The GPIO mux registers must be configured for this peripheral. To avoid glitches on the pins, the GPyGMUX bits must be configured first (while keeping the corresponding GPyMUX bits at the default of zero), followed by writing the GPyMUX register to the desired value.

See the *GPIO* chapter for more details on GPIO mux, GPIO settings, and XBAR configuration.

7.4.5.4 ePWM Modules Overview

Eight submodules are included in every ePWM peripheral. Each of these submodules performs specific tasks that can be configured by software.

[Table 7-107](#) lists the eight key submodules together with a list of their main configuration parameters. For example, if you need to adjust or control the duty cycle of a PWM waveform, then you should see the counter-compare submodule in [Section 7.4.5.6](#) for relevant details.

Table 7-107. Submodule Configuration Parameters

Submodule	Configuration Parameter or Option
Time Base (TB)	<ul style="list-style-type: none"> • Scale the time-base clock (TBCLK) relative to the ePWM clock (EPWMCLK). • Configure the PWM time-base counter (TBCTR) frequency or period. • Set the mode for the time-base counter: <ul style="list-style-type: none"> – count-up mode: used for asymmetric PWM – count-down mode: used for asymmetric PWM – count-up-and-down mode: used for symmetric PWM • Configure the time-base phase relative to another ePWM module. • Synchronize the time-base counter between modules through hardware or software. • Configure the direction (up or down) of the time-base counter after a synchronization event. • Simultaneous writes to the TBPRD registers on all PWM's corresponding to the configuration on EPWMXLINK. • Configure how the time-base counter will behave when the device is halted by an emulator. • Specify the source for the synchronization output of the ePWM module • Configure one shot and global load of registers in this module.
Counter Compare (CC)	<ul style="list-style-type: none"> • Specify the PWM duty cycle for output EPWMxA and/or output EPWMxB • Specify the time at which switching events occur on the EPWMxA or EPWMxB output • Specify the programmable delay for interrupt and SOC generation with additional comparators • Simultaneous writes to the CMPA, CMPB, CMPC, CMPD registers on all PWM's corresponding to the configuration on EPWMXLINK. • Configure one shot and global load of registers in this module.
Action Qualifier (AQ)	<ul style="list-style-type: none"> • Specify the type of action taken when a time-base counter-compare, trip-zone submodule, or comparator event occurs: <ul style="list-style-type: none"> – No action taken – Output EPWMxA and/or EPWMxB switched high – Output EPWMxA and/or EPWMxB switched low – Output EPWMxA and/or EPWMxB toggled • Force the PWM output state through software control • Configure and control the PWM dead band through software • Configure one shot and global load of registers in this module.

Table 7-107. Submodule Configuration Parameters (continued)

Submodule	Configuration Parameter or Option
Dead Band (DB)	<ul style="list-style-type: none"> Control of traditional complementary dead-band relationship between upper and lower switches Specify the output rising-edge-delay value Specify the output falling-edge delay value Bypass the dead-band module entirely. In this case the PWM waveform is passed through without modification. Option to enable half-cycle clocking for double resolution. Allow ePWMxB phase shifting with respect to the ePWMxA output. Configure one shot and global load of registers in this module.
PWM Chopper (PC)	<ul style="list-style-type: none"> Create a chopping (carrier) frequency. Pulse width of the first pulse in the chopped pulse train. Duty cycle of the second and subsequent pulses. Bypass the PWM chopper module entirely. In this case the PWM waveform is passed through without modification.
Trip Zone (TZ)	<ul style="list-style-type: none"> Configure the ePWM module to react to one, all, or none of the trip-zone signals or digital compare events. Specify the trip action taken when a fault occurs: <ul style="list-style-type: none"> Force EPWMxA and/or EPWMxB high Force EPWMxA and/or EPWMxB low Force EPWMxA and/or EPWMxB to a high-impedance state Configure EPWMxA and/or EPWMxB to ignore any trip condition. Configure how often the ePWM will react to each trip-zone signal: <ul style="list-style-type: none"> One-shot Cycle-by-cycle Enable the trip-zone to initiate an interrupt. Bypass the trip-zone module entirely. Programmable option for cycle-by-cycle trip clear If desired, independently configure trip actions taken when time-base counter is counting down.
Event Trigger (ET)	<ul style="list-style-type: none"> Enable the ePWM events that will trigger an interrupt. Enable ePWM events that will trigger an ADC start-of-conversion event. Specify the rate at which events cause triggers (every occurrence or every 2nd or up to 15th occurrence) Poll, set, or clear event flags
Digital Compare (DC)	<ul style="list-style-type: none"> Enables comparator (COMP) module outputs and trip zone signals which are configured using the Input X-BAR to create events and filtered events Specify event-filtering options to capture TBCTR counter, generate blanking window, or insert delay in PWM output or time-base counter based on captured value.

7.4.5.5 Time-Base (TB) Submodule

Each ePWM module has its own time-base submodule that determines all of the event timing for the ePWM module. Built-in synchronization logic allows the time-base of multiple ePWM modules to work together as a single system.

7.4.5.5.1 Purpose of the Time-Base Submodule

You can configure the time-base submodule for the following:

- Specify the ePWM time-base counter (TBCTR) frequency or period to control how often events occur.
- Manage time-base synchronization with other ePWM modules.
- Maintain a phase relationship with other ePWM modules.
- Set the time-base counter to count-up, count-down, or count-up-and-down mode.
- Generate the following events:
 - CTR = PRD: Time-base counter equal to the specified period (TBCTR = TBPRD).
 - CTR = Zero: Time-base counter equal to zero (TBCTR = 0x00).
- Configure the rate of the time-base clock; a prescaled version of the ePWM clock (EPWMCLK). This allows the time-base counter to increment/decrement at a slower rate.

Note

If it is required by the application code to updated the TBCTR value through software, while the TBCTR is counting, it is important to note that the Time-Base module will need at least 1 TBCLK cycle for the Time-Base related events to be realized. Hence the TBCTR should either be written with TBCTR = PRD-1 instead of TBCTR = PRD (in case the counter is counting up) and should be written as TBCTR = 1 instead of TBCTR = 0(in case the counter is counting down) for the events to be realized.

7.4.5.5.2 Controlling and Monitoring the Time-Base Submodule

The block diagram in Figure 7-115 shows the critical signals and registers of the time-base submodule. Table 7-108 provides descriptions of the key signals associated with the time-base submodule.

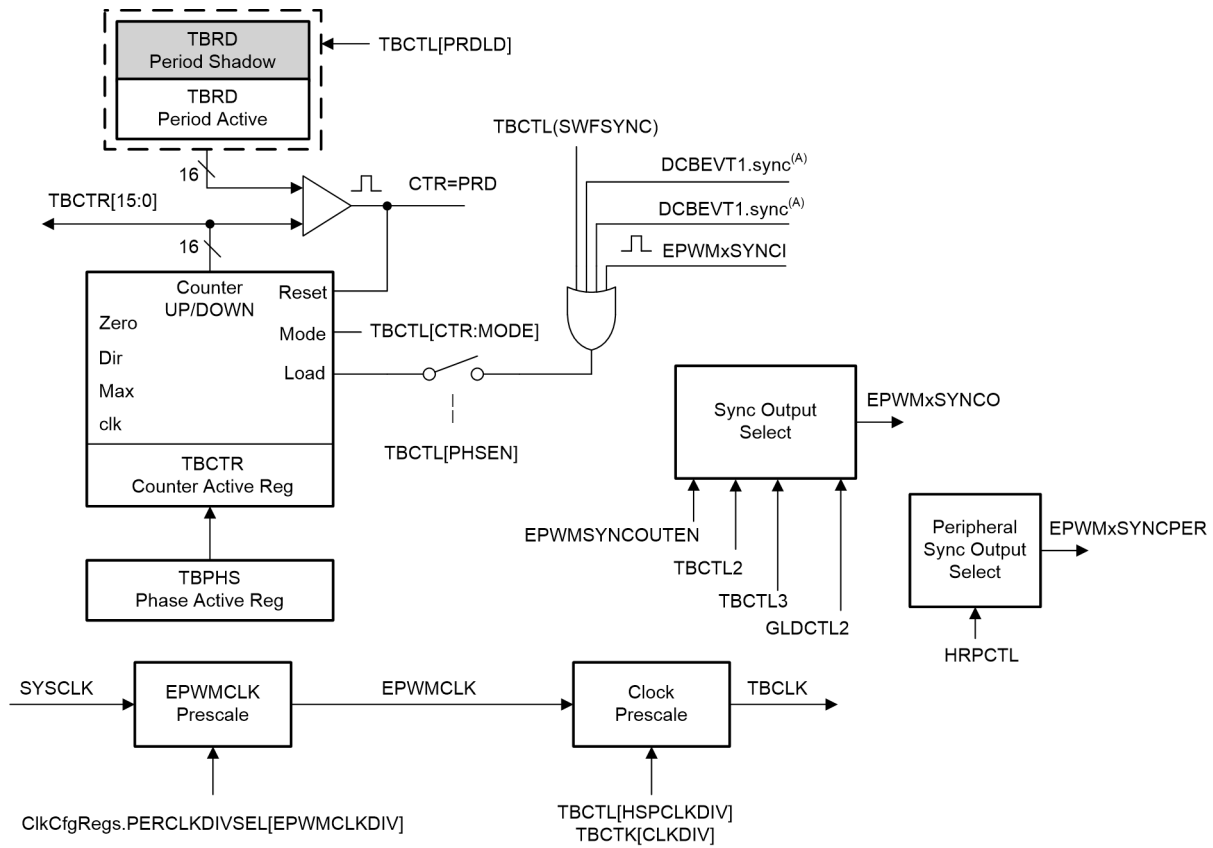

A. These signals are generated by the digital compare (DC) submodule.

Figure 7-115. Time-Base Submodule Signals and Registers

Table 7-108. Key Time-Base Signals

Signal	Description
EPWMxSYNCl	Time-base synchronization input. Input pulse used to synchronize the time-base counter with the counter of other ePWM modules. For more information on all of the signals available for synchronization, see EPWMSYNClNSEL. For information on the synchronization order of a particular device, see Section 7.4.5.5.3.3 .
EPWMxSYNCO	Time-base synchronization output. This output pulse is used to synchronize the counter of other ePWM modules. Using EPWMSYNCOOUTEN, TBCTL2, TBCTL3 and GLDCTL2, the source of the output pulse is selected.
EPWMxSYNCPER	Time-base peripheral synchronization output. This output signal is used to synchronize the CMPSS to the EPWM. The output signal can be configured using the HRPCTL register. Note that this signal has no relation with the HRPWM.
CTR = PRD	Time-base counter equal to the specified period. This signal is generated whenever the counter value is equal to the active period register value. That is when TBCTR = TBPRD.
CTR = Zero	Time-base counter equal to zero This signal is generated whenever the counter value is zero. That is when TBCTR equals 0x00.
CTR = CMPB	Time-base counter equal to active counter-compare B register (TBCTR = CMPB). This event is generated by the counter-compare submodule and used by the synchronization out logic
CTR_dir	Time-base counter direction. Indicates the current direction of the ePWM's time-base counter. The signal is high when the counter is increasing and the signal is low when the counter is decreasing.
CTR_max	Time-base counter equal max value. (TBCTR = 0xFFFF) Generated event when the TBCTR value reaches the maximum value. This signal is only used only as a status bit
TBCLK	Time-base clock. This is a prescaled version of the ePWM clock (EPWMCLK) and is used by all submodules within the ePWM. This clock determines the rate at which time-base counter increments or decrements.

7.4.5.5.3 Calculating PWM Period and Frequency

The frequency of PWM events is controlled by the time-base period (TBPRD) register and the mode of the time-base counter. Figure 7-116 shows the period (T_{pwm}) and frequency (F_{pwm}) relationships for the up-count, down-count, and up-down-count time-base counter modes when the period is set to 4 (TBPRD = 4). The time increment for each step is defined by the time-base clock (TBCLK) which is a prescaled version of the ePWM clock (EPWMCLK).

The time-base counter has three modes of operation selected by the time-base control register (TBCTL):

- **Up-Down-Count Mode:**

In up-down-count mode, the time-base counter starts from zero and increments until the period (TBPRD) value is reached. When the period value is reached, the time-base counter then decrements until it reaches zero. At this point the counter repeats the pattern and begins to increment.

- **Up-Count Mode:**

In this mode, the time-base counter starts from zero and increments until it reaches the value in the period register (TBPRD). When the period value is reached, the time-base counter resets to zero and begins to increment once again.

- **Down-Count Mode:**

In down-count mode, the time-base counter starts from the period (TBPRD) value and decrements until it reaches zero. When it reaches zero, the time-base counter is reset to the period value and it begins to decrement once again.

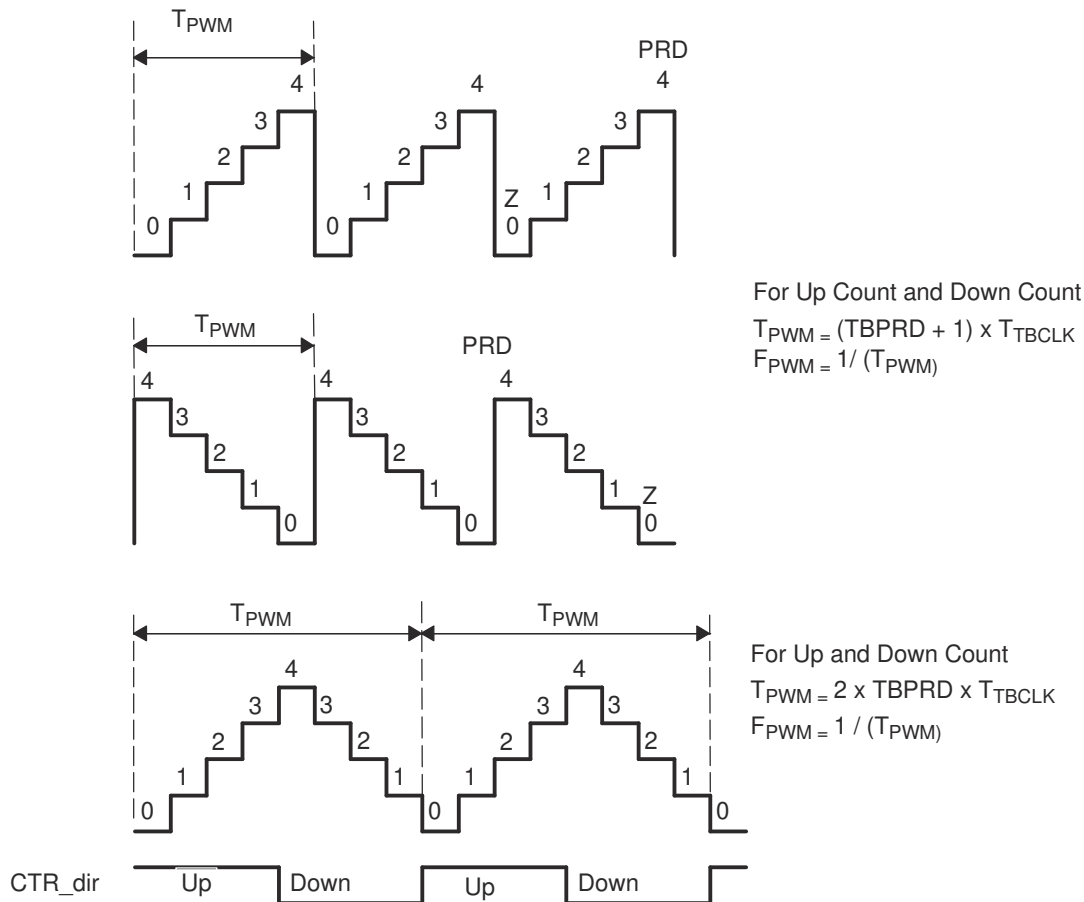

Figure 7-116. Time-Base Frequency and Period

7.4.5.5.3.1 Time-Base Period Shadow Register

The time-base period register (TBPRD) has a shadow register. Shadowing allows the register update to be synchronized with the hardware. The following definitions are used to describe all shadow registers in the ePWM module:

- **Active Register**

The active register controls the hardware and is responsible for actions that the hardware causes or invokes.

- **Shadow Register**

The shadow register buffers or provides a temporary holding location for the active register. It has no direct effect on any control hardware. At a strategic point in time the shadow register's content is transferred to the active register. This prevents corruption or spurious operation due to the register being asynchronously modified by software.

The memory address of the shadow period register is the same as the active register. Which register is written to or read from is determined by the TBCTL[PRDL] bit. This bit enables and disables the TBPRD shadow register as follows:

- **Time-Base Period Shadow Mode:**

The TBPRD shadow register is enabled when TBCTL[PRDL] = 0. Reads from and writes to the TBPRD memory address go to the shadow register. The shadow register contents are transferred to the active register (TBPRD (Active) ← TBPRD (shadow)) when the time-base counter equals zero (TBCTR = 0x00) and/or a sync event as determined by the TBCTL2[PRDLDSYNC] bit. The PRDLDSYNC bit is valid only if TBCTL[PRDL] = 0. By default the TBPRD shadow register is enabled. The sources for the SYNC input is explained in [Section 7.4.5.5.3.3](#).

The global load control mechanism can also be used with the time-base period register by configuring the appropriate bits in the global load configuration register (GLDCFG). When global load mode is selected the transfer of contents from shadow register to active register, for all registers that have this mode enabled, occurs at the same event as defined by the configuration bits in Global Shadow to Active Load Control Register (GLDCTL). Global load control mechanism is explained in [Section 7.4.5.5.8](#).

- **Time-Base Period Immediate Load Mode:**

If immediate load mode is selected (TBCTL[PRDL] = 1), then a read from or a write to the TBPRD memory address goes directly to the active register.

7.4.5.5.3.2 Time-Base Clock Synchronization

The TBCLKSYNC bit in the peripheral clock enable registers allows all users to globally synchronize all enabled ePWM modules to the time-base clock (TBCLK). When set, all enabled ePWM module clocks are started with the first rising edge of TBCLK aligned. For perfectly synchronized TBCLKs, the prescalers for each ePWM module must be set identically.

The proper procedure for enabling ePWM clocks is as follows:

1. Enable ePWM module clocks in the PCLKCRx register
2. Set TBCLKSYNC= 0
3. Configure ePWM modules
4. Set TBCLKSYNC= 1

7.4.5.5.3.3 Time-Base Counter Synchronization

The ePWM synchronization scheme allows for increased flexibility of synchronization of the ePWM modules. Each ePWM module has a synchronization input (SYNCI), a synchronization output (SYNCO) and a peripheral synchronization output (SYNCPER).

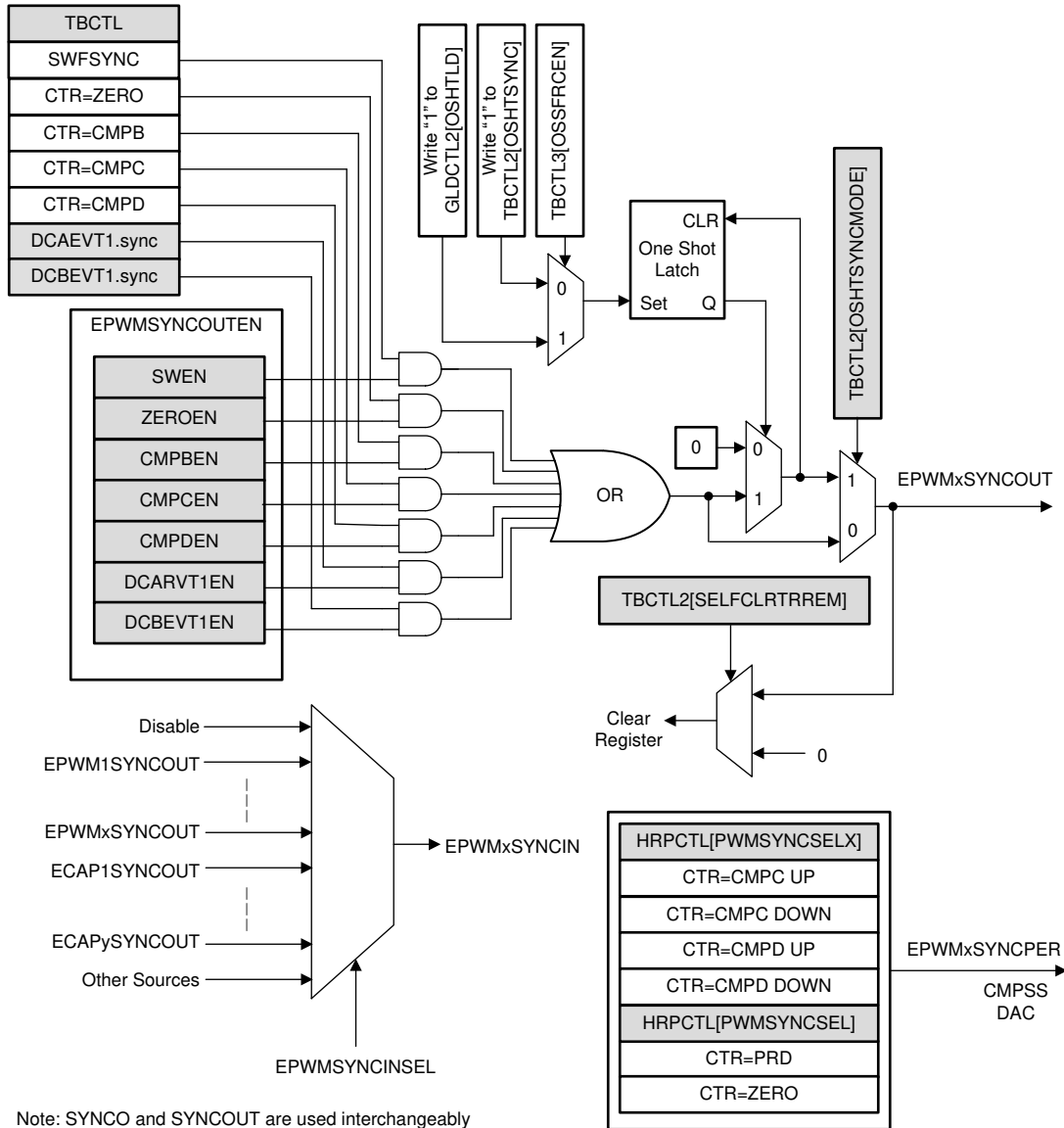

Note: SYNCO and SYNCOOUT are used interchangeably

Figure 7-117. Time-Base Counter Synchronization Scheme

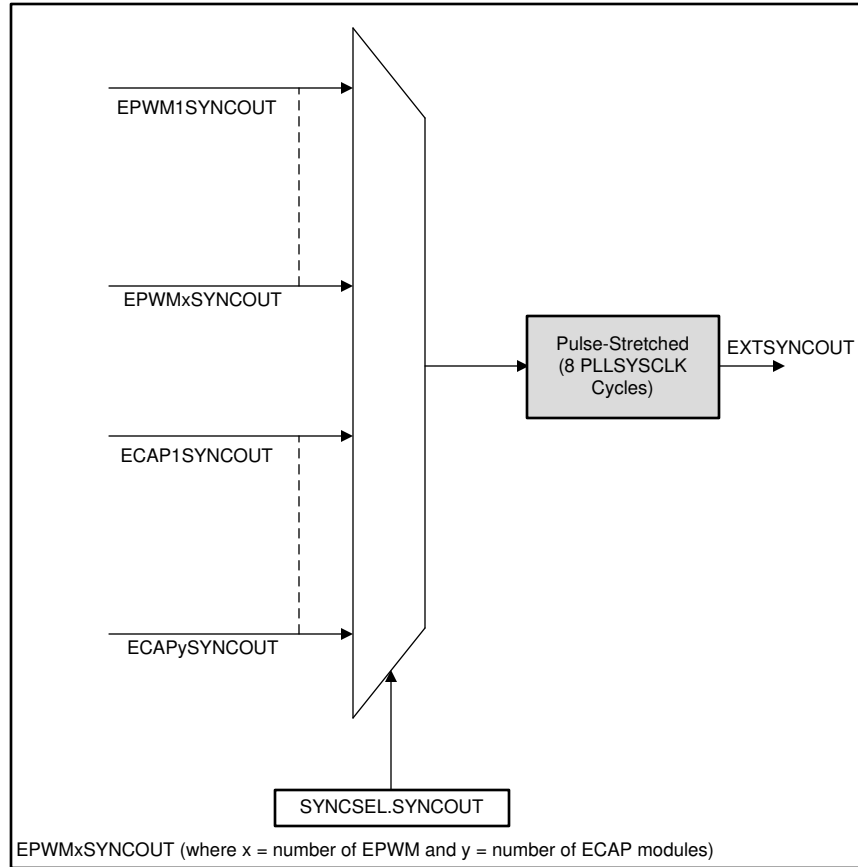

Figure 7-118. ePWM External SYNC Output

Note

See the data sheet for the number of ePWM and eCAP modules available on your specific device.

Each ePWM module can be configured to use or ignore the synchronization input. If the TBCTL[PHSEN] bit is set, then the time-base counter (TBCTR) of the ePWM module is automatically loaded with the phase register (TBPHS) contents when one of the following conditions occur:

- **EPWMxSYNCl: Synchronization Input Pulse:**

The value of the phase register is loaded into the counter register when an input synchronization pulse is detected (TBPHS → TBCTR). This operation occurs on the next valid time-base clock (TBCLK) edge.

- **Software Forced Synchronization Pulse:**

Writing a 1 to the TBCTL[SWFSYNC] control bit invokes a software forced synchronization. This pulse is ORed with the synchronization input signal, and therefore has the same effect as a pulse on EPWMxSYNCl.

- **Digital Compare Event Synchronization Pulse:**

DCAEVT1 and DCBEVT1 digital compare events can be configured to generate synchronization pulses which have the same affect as EPWMxSYNCl.

Note

If the EPWMxSYNCl signal is held high, the sync does not continuously occur. The EPWMxSYNCl is rising edge activated.

This feature enables the ePWM module to be automatically synchronized to the time base of another ePWM module. Lead or lag phase control can be added to the waveforms generated by different ePWM modules to synchronize them. In up-down-count mode, the TBCTL[PHSDIR] bit configures the direction of the time-base counter immediately after a synchronization event. The new direction is independent of the direction prior to the synchronization event. The PHSDIR bit is ignored in count-up or count-down modes. See [Figure 7-119](#) through [Figure 7-122](#) for examples.

Clearing the TBCTL[PHSEN] bit configures the ePWM to ignore the synchronization input pulse.

7.4.5.5.3.4 ePWM SYNC Selection

[Table 7-109](#) specifies the sources for the ePWM SYNC input and output.

Table 7-109. ePWM SYNC Selection

EPWMSYNClSEL.SEL	SYNC Source
0x0	Reserved
0x1	EPWM0 SYNCOUT
0x2	EPWM1 SYNCOUT
0x3	EPWM2 SYNCOUT
0x4	EPWM3 SYNCOUT
0x5	EPWM4 SYNCOUT
0x6	EPWM5 SYNCOUT
0x7	EPWM6 SYNCOUT
0x8	EPWM7 SYNCOUT
0x9	EPWM8 SYNCOUT
0xA	EPWM9 SYNCOUT
0xB	EPWM10 SYNCOUT
0xC	EPWM11 SYNCOUT
0xD	EPWM12 SYNCOUT
0xE	EPWM13 SYNCOUT
0xF	EPWM14 SYNCOUT
0x10	EPWM15 SYNCOUT
0x11	EPWM16 SYNCOUT
0x12	EPWM17 SYNCOUT
0x13	EPWM18 SYNCOUT

Table 7-109. ePWM SYNC Selection (continued)

EPWMSYNCINSEL.SEL	SYNC Source
0x14	EPWM19 SYNCOUT
0x15	EPWM20 SYNCOUT
0x16	EPWM21 SYNCOUT
0x17	EPWM22 SYNCOUT
0x18	EPWM23 SYNCOUT
0x19-0x3F	Reserved
0x40	ECAP0 SYNCOUT
0x41	ECAP1 SYNCOUT
0x42	ECAP2 SYNCOUT
0x43	ECAP3 SYNCOUT
0x44	ECAP4 SYNCOUT
0x45	ECAP5 SYNCOUT
0x46	ECAP6 SYNCOUT
0x47	ECAP7 SYNCOUT
0x48	ECAP8 SYNCOUT
0x49	ECAP9 SYNCOUT
0x4A-0x4F	Reserved
0x50	INPUTXBAR OUT.4
0x51	INPUTXBAR OUT.20
0x52-0x57	Reserved
0x58	TIMESYNCXBAR SYNCPWMOUT0
0x59	TIMESYNCXBAR SYNCPWMOUT1
0x5A-0x5F	Reserved
0x60	FSI RX0 RXTRIG0
0x61	FSI RX0 RXTRIG1
0x62	FSI RX0 RXTRIG2
0x63	FSI RX0 RXTRIG3
0x64	FSI RX1 RXTRIG0
0x65	FSI RX1 RXTRIG1
0x66	FSI RX1 RXTRIG2
0x67	FSI RX1 RXTRIG3
0x68	FSI RX2 RXTRIG0
0x69	FSI RX2 RXTRIG1
0x6A	FSI RX2 RXTRIG2
0x6B	FSI RX2 RXTRIG3
0x6C	FSI RX3 RXTRIG0
0x6D	FSI RX3 RXTRIG1
0x6E	FSI RX3 RXTRIG2
0x6F	FSI RX3 RXTRIG3
0x70-0x7F	Reserved

7.4.5.5.4 Phase Locking the Time-Base Clocks of Multiple ePWM Modules

The CONTROLSS_CTRL.EPWM_CLK_SYNC register has bits corresponding to each instance of ePWM. When EPWM_CLK_SYNC = 0, the time-base clock of all ePWM modules is stopped (default). When EPWM_CLK_SYNC = 1, all corresponding ePWMs time-base clocks are started with the rising edge of TBCLK aligned. For perfectly synchronized TBCLKs, the prescaler bits in the TBCTL register of each ePWM module must be set identically.

The TBCLKSYNC bit can be used to globally synchronize the time-base clocks of all enabled ePWM modules on a device. This bit is part of the device's clock enable registers and is described in the *System Control and Interrupts* section of this manual. When TBCLKSYNC = 0, the time-base clock of all ePWM modules is stopped (default). When TBCLKSYNC = 1, all ePWM time-base clocks are started with the rising edge of TBCLK aligned. For perfectly synchronized TBCLKs, the prescaler bits in the TBCTL register of each ePWM module must be set identically. The proper procedure for enabling the ePWM clocks is as follows:

1. Enable the individual ePWM module clocks. This is described in the *System Control and Interrupts* chapter.
2. Set EPWM_CLK_SYNC = 0. This will stop the time-base clock within any enabled ePWM module.
3. Configure the prescaler values and desired ePWM modes.
4. Set EPWM_CLK_SYNC = 1.

7.4.5.5.5 Simultaneous Writes to TBPRD and CMPx Registers Between ePWM Modules

For variable frequency applications, there is a need for simultaneous writes of TBPRD and CMPx registers between ePWM modules. This prevents situations where a CTR = 0 or CTR = PRD pulse forces a shadow to active load of these registers before all registers are updated between ePWM modules (resulting in some registers being loaded from new shadow values while others are loaded from old shadow values). To support this, an ePWM register linking scheme for TBPRD:TBPRDHR, CMPA:CMPAHR, CMPB:CMPBHR, CMPC, and CMPD registers between PWM modules has been added.

For a particular ePWM module # A, user code writes “B+1”, to the linked register bit-field in EPWMXLINK. “B” is the ePWM module # being linked to (that is, writes to the ePWM module “B” TBPRD:TBPRDHR, CMPA:CMPAHR, CMPB:CMPBHR, or CMPC will simultaneously be written to corresponding register in ePWM module “A”). For instance if ePWM3 EPWMXLINK register is configured so that CMPA:CMPAHR are linked to ePWM1, then a write to CMPA:CMPAHR in ePWM 1 will simultaneously write the same value to CMPA:CMPAHR in ePWM3. If ePWM4 also has its CMPA:CMPAHR registers linked to ePWM1, then a write to ePWM 1 will write the same value to the CMPA:CMPAHR registers in both ePWM3 and ePWM4.

The register description for EPWMXLINK clearly explains the linked register bit-field values for corresponding ePWM. An example of using the EPWMXLINK is linking ePWM2 CMPA with CMPA of ePWM1. In this case, a write to CMPA of ePWM1 will also change the CMPA value for ePWM2.

7.4.5.5.6 Time-Base Counter Modes and Timing Waveforms

The time-base counter operates in one of four modes:

- Up-count mode that is asymmetrical
- Down-count mode that is asymmetrical
- Up-down-count that is symmetrical
- Frozen where the time-base counter is held constant at the current value

To illustrate the operation of the first three modes, the following timing diagrams show when events are generated and how the time-base responds to an EPWMxSYNCl signal.

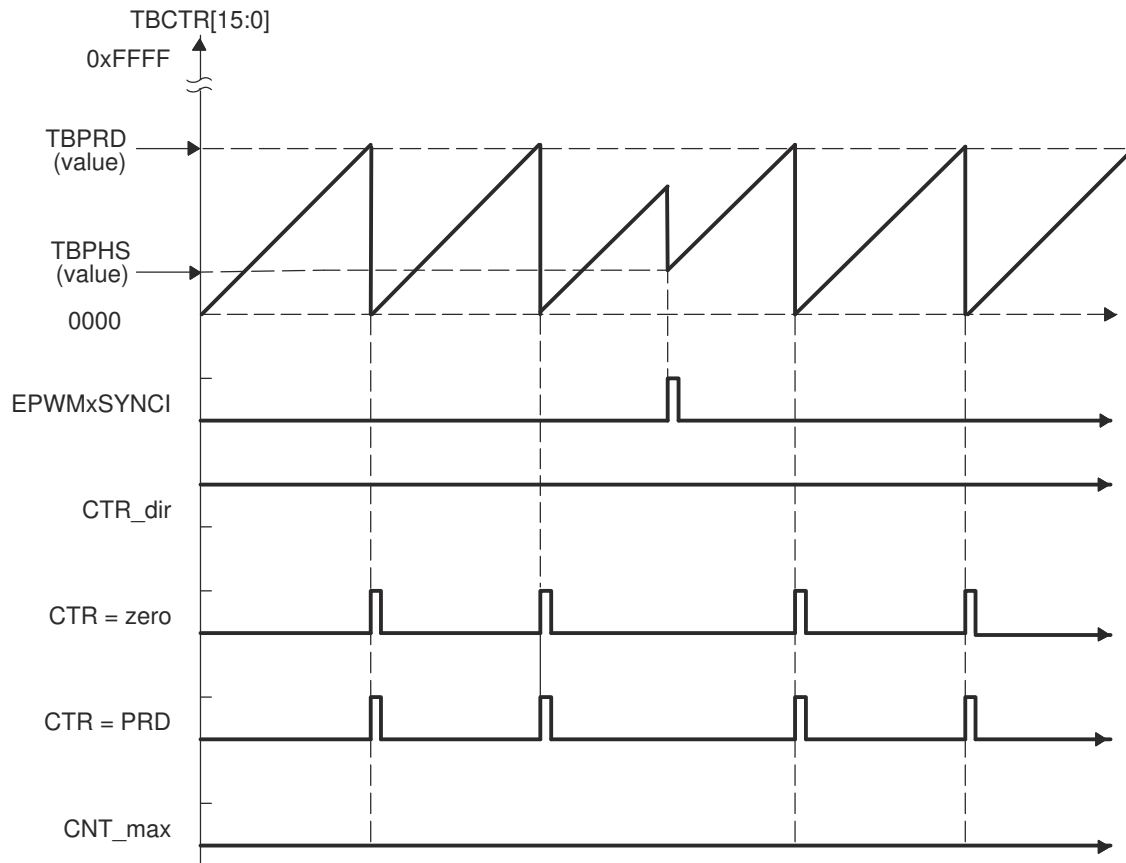

Figure 7-119. Time-Base Up-Count Mode Waveforms

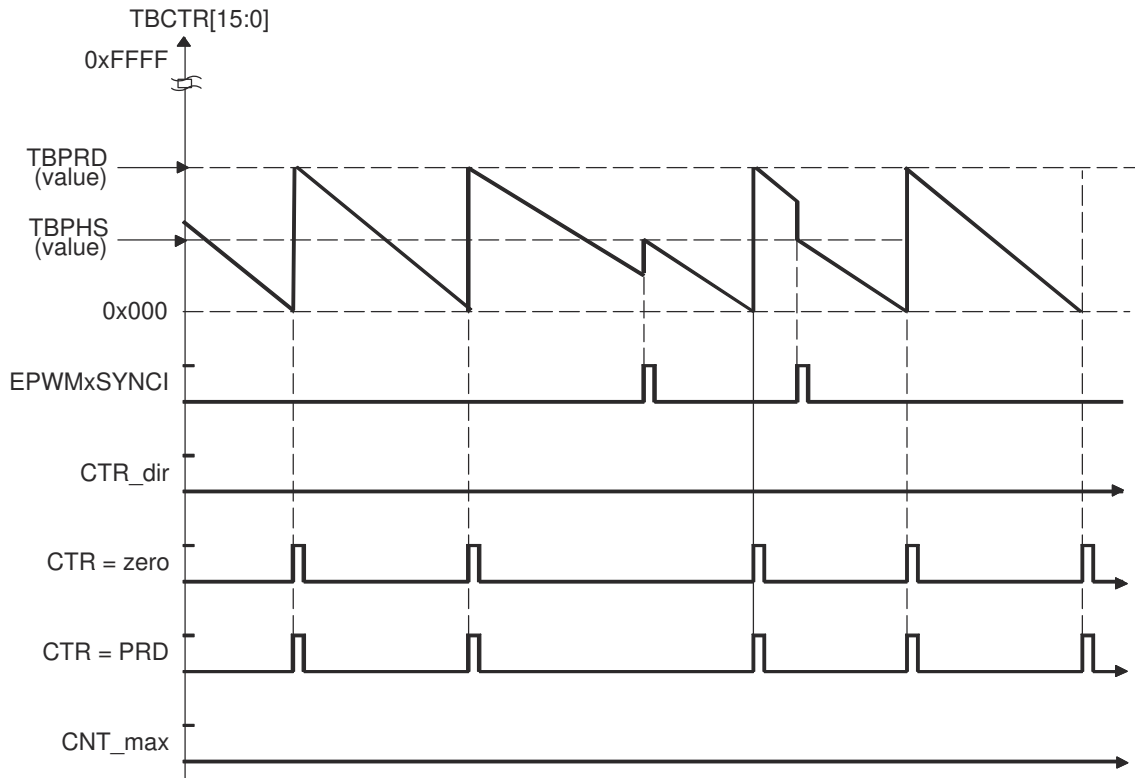

Figure 7-120. Time-Base Down-Count Mode Waveforms

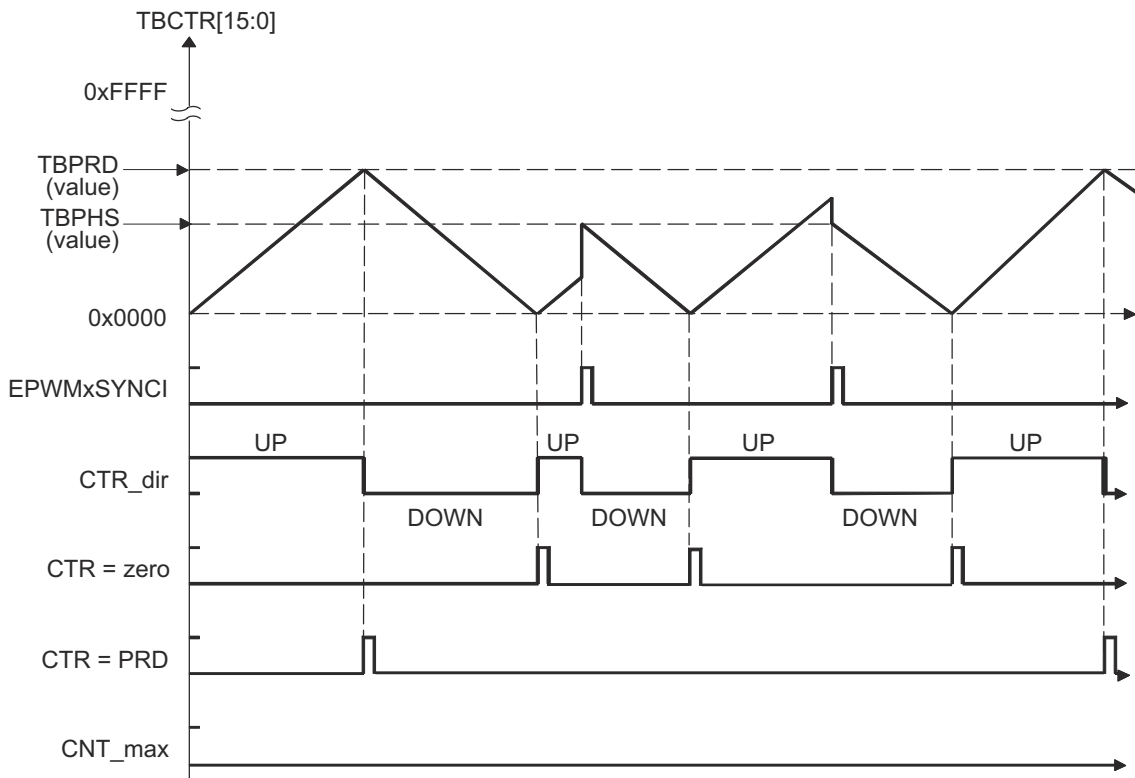

Figure 7-121. Time-Base Up-Down-Count Waveforms, TBCTL[PHSDIR = 0] Count Down On Synchronization Event

ADVANCE INFORMATION

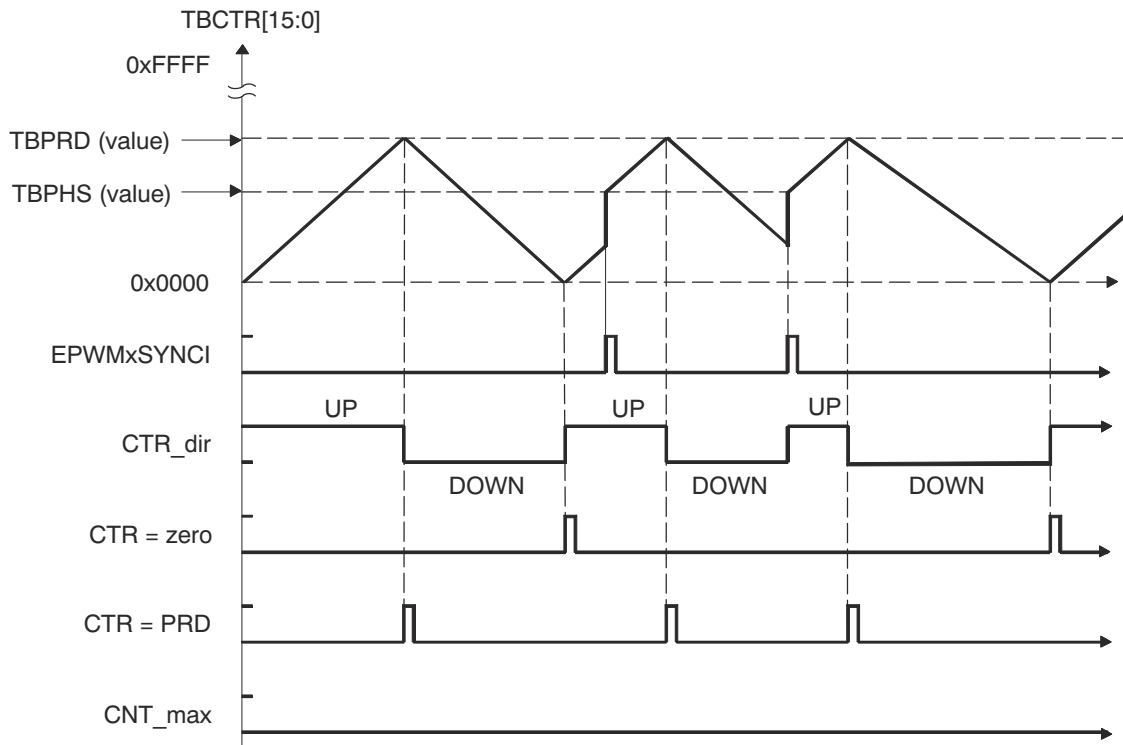

Figure 7-122. Time-Base Up-Down Count Waveforms, TBCTL[PHSDIR = 1] Count Up On Synchronization Event

7.4.5.5.7 Edge Detection Within a Programmable TBCTR Range

An edge detection within a programmable TBCTR range is added in type 5 ePWM. When a CAPIN edge does **NOT** occur within a specified range of TBCTR values, the CAPEVT signal is generated. The TBCTR range during which a CAPIN edge must occur is determined by XMINMAX_ACTIVE register. A gating signal CAPGATE can also be used to gate the CAPIN edge.

Figure 7-123 shows how the CAPIN and CAPGATE signal source is selected.

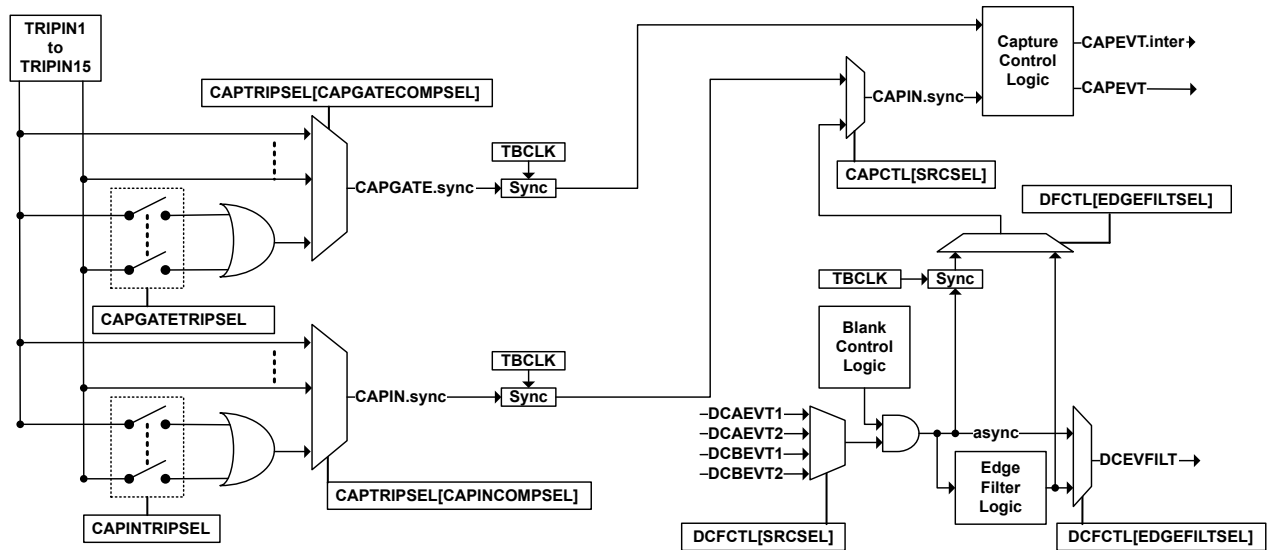

Figure 7-123. CAPIN and CAPGATE Source Selection

Using the CAPIN signal and the CAPGATE signal, the Capture Control Logic can generate a CAPEVT signal if an edge is **NOT** detected within a specified range of TBCTR values.

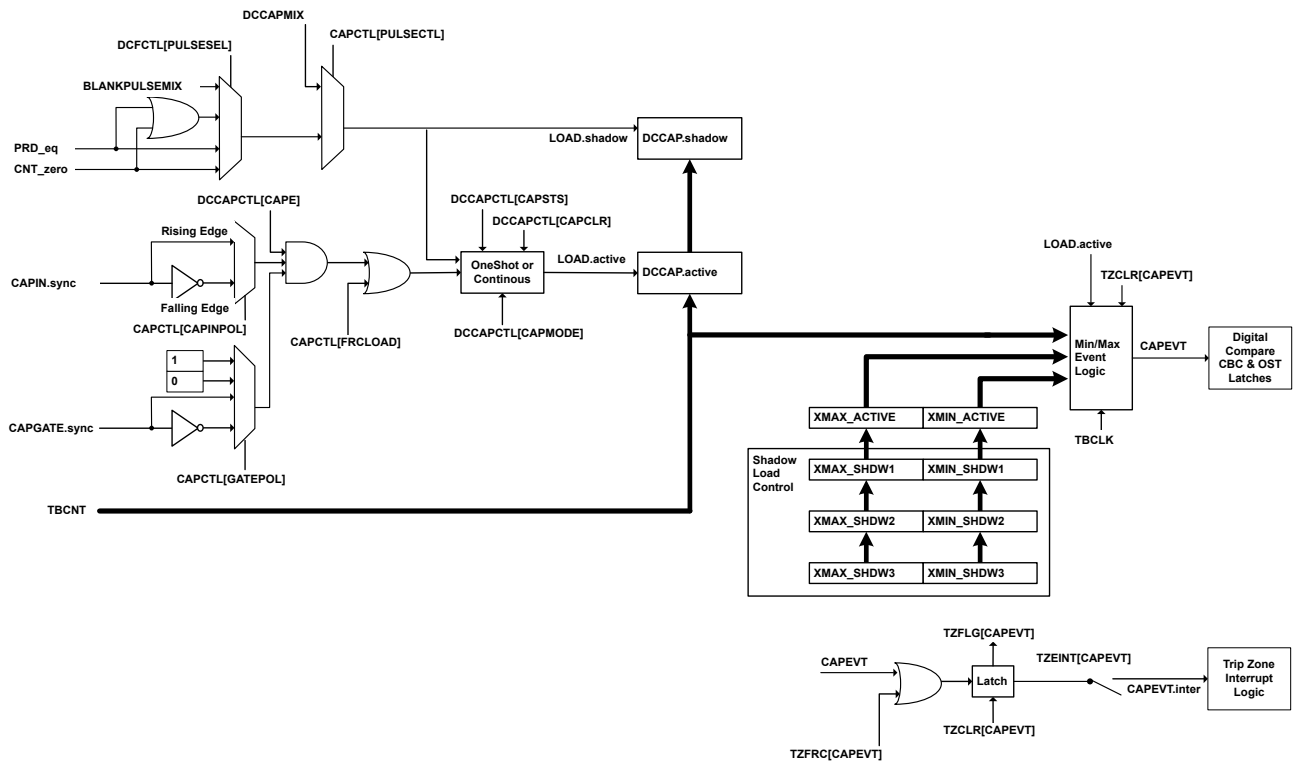

Figure 7-124. CAPEVT Signal Generation

7.4.5.5.8 Global Load

Figure 7-125 illustrates the signals and registers associated with the global load feature.

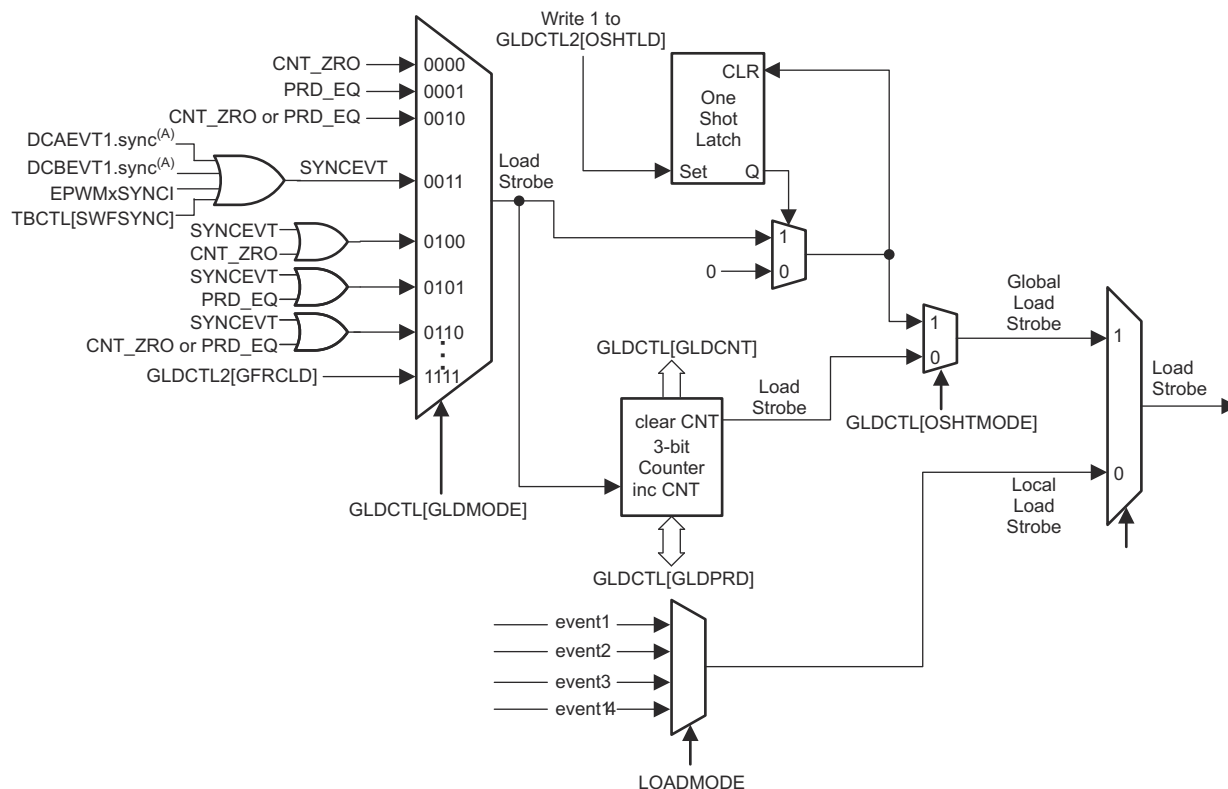

Figure 7-125. Global Load: Signals and Registers

Note

The SYNCEVT signal is only propagated through when PHSEN is SET.

When this feature is enabled, the transfer of contents from the shadow register to the active register, for all registers that have this mode enabled, occurs at the same event as defined by the configuration bits in Global Shadow to Active Load Control Register (GLDCTL[GLDMODE]). When GLDCTL[GLD] = '1', shadow to active load event selection bits for individual shadowed registers are ignored and global load mode takes effect for the corresponding registers enabled by GLDCFG[REGx].

When GLDCTL[GLD] = '1' and GLDCFG[REGx] = '0' global load mode does not affect the corresponding register (REGx). Shadow to active load event selection bits for individual shadowed registers decide how the transfer of contents from shadow register to active register takes place.

7.4.5.5.8.1 Global Load Pulse Pre-Scalar

This feature provides the capability to choose shadow to active transfers to happen once in 'N' occurrences of selected global load pulse (GLDCTL[GLDMODE]). This pre-scale functionality is not available for registers that cannot or are not configured to use the global load mechanism (that is, GLDCTL[GLD] = '0' or GLDCFG[REGx] = '0').

7.4.5.5.8.2 One-Shot Load Mode

This feature allows users to cause the shadow register to active register transfers to occur once. When `GLDCTL2[OSHTLD] = '1'` the shadow to active register transfer, for registers that are configured to use the global load mechanism, takes place on the event selected by `GLDCTL[GLDMODE]`.

Software force loading of contents from shadow register to active register is possible by using `GLDCTL2[GFRCLD]`. The `GLDCTL2` register can also be linked across multiple PWM modules by using `EPWMXLINK[GLDCTL2LINK]`. This, along with the one-shot load mode feature discussed above, provides a method to correctly update multiple PWM registers in one or more PWM modules at certain PWM events or, if desired, in the same clock cycle. This is very useful in variable frequency applications and/or multi-phase interleaved applications.

Note

One-shot load mode should **NOT** be used when high-resolution mode is enabled.

7.4.5.5.8.3 One-Shot Sync Mode

You can enable the one-shot sync mode to generate a `SYNCOUT` pulse by configuring `TBCTL2[OSHTSYNCMODE]` and setting the `TBCTL2[OSHTSYNC]` bit as shown in [Figure 7-126](#).

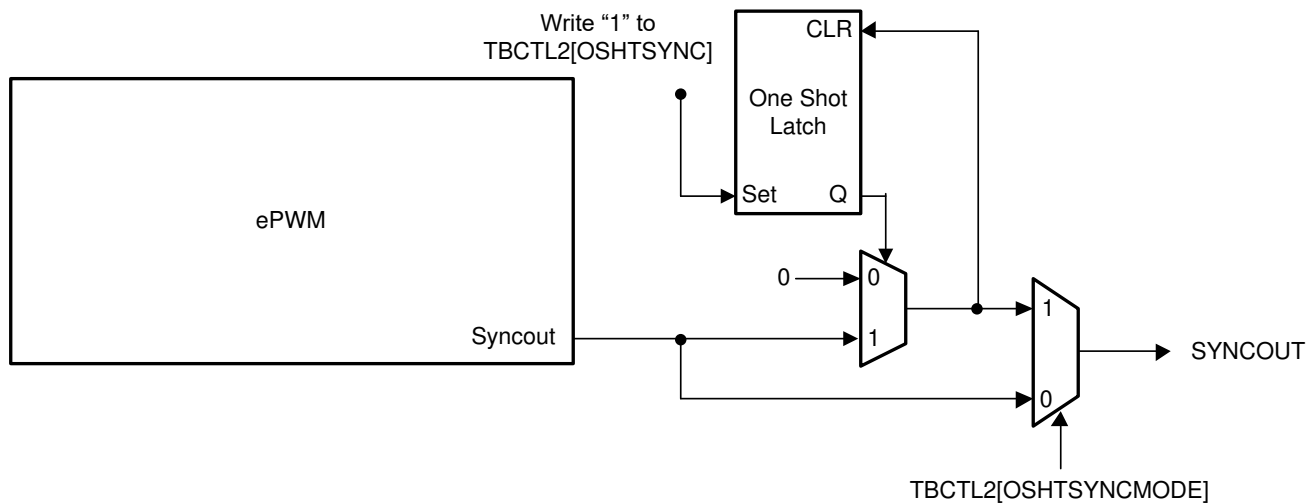

Figure 7-126. One-Shot Sync Mode

7.4.5.6 Counter-Compare (CC) Submodule

7.4.5.6.1 Purpose of the Counter-Compare Submodule

The counter-compare submodule takes as input the time-base counter value. This value is continuously compared to the counter-compare A (CMPA), counter-compare B (CMPB), counter-compare C (CMPC), and counter-compare D (CMPD) registers. When the time-base counter is equal to one of the compare registers, the counter-compare unit generates an appropriate event.

The counter-compare:

- Generates events based on programmable time stamps using the CMPA, CMPB, CMPC, and CMPD registers:
 - CTR = CMPA: Time-base counter equals counter-compare A register (TBCTR = CMPA)
 - CTR = CMPB: Time-base counter equals counter-compare B register (TBCTR = CMPB)
 - CTR = CMPC: Time-base counter equals counter-compare C register (TBCTR = CMPC)
 - CTR = CMPD: Time-base counter equals counter-compare D register (TBCTR = CMPD)
- Controls the PWM duty cycle, if the action-qualifier submodule is configured appropriately using counter-compare A (CMPA) and counter-compare B (CMPB)
- Shadows new compare values to prevent corruption or glitches during the active PWM cycle

7.4.5.6.2 Controlling and Monitoring the Counter-Compare Submodule

The counter-compare submodule operation is shown in Figure 7-127.

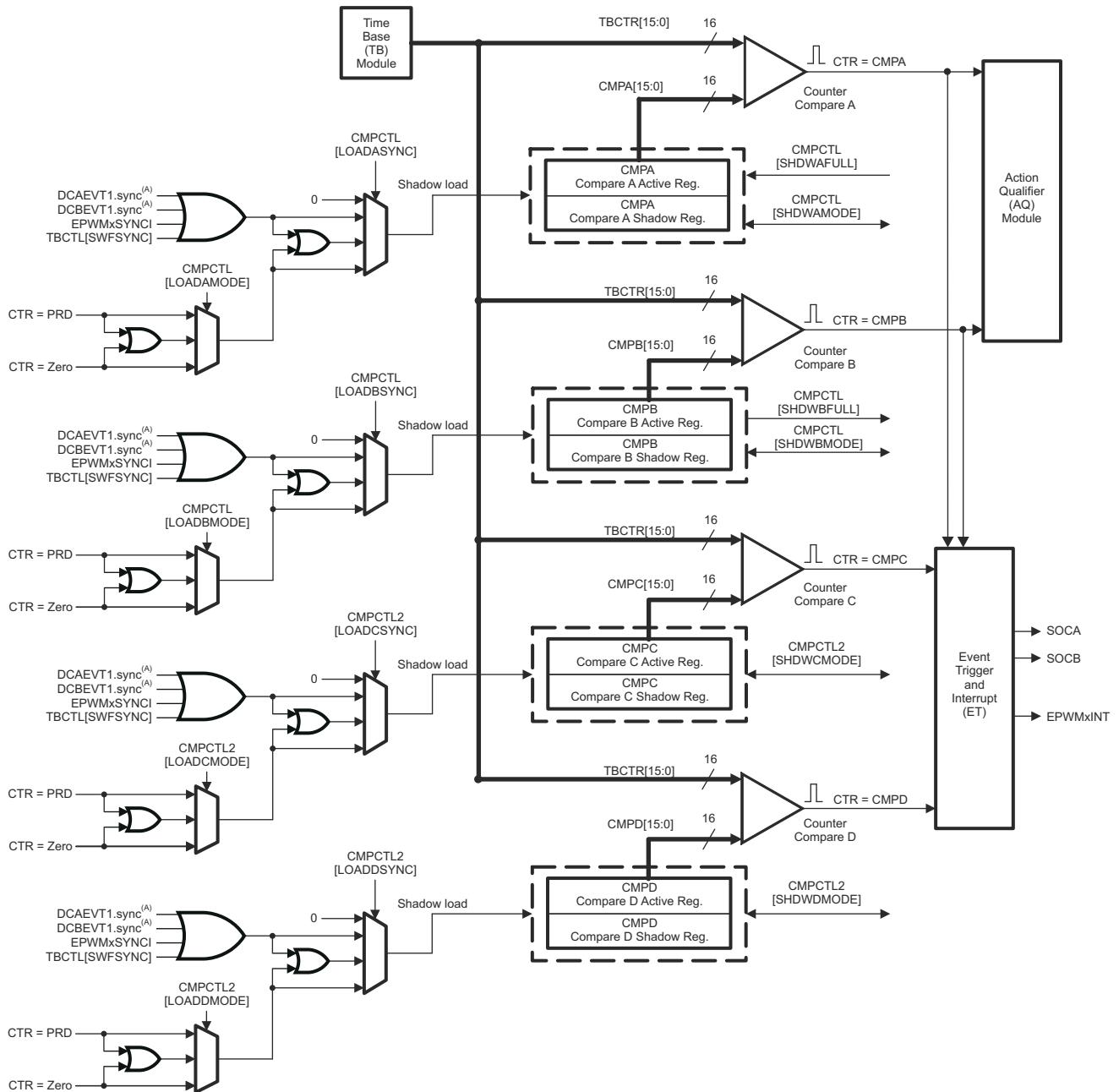

ADVANCE INFORMATION

A. These events are generated by the ePWM digital compare (DC) submodule based on the levels of the TRIPIN inputs (for example, CMPSSx and TZ signals).

Figure 7-127. Detailed View of the Counter-Compare Submodule

7.4.5.6.3 Operational Highlights for the Counter-Compare Submodule

The counter-compare submodule is responsible for generating events which can be used in the action-qualifier and/or event-trigger submodules. There are four independent compare events:

1. CTR = CMPA: Time-base counter equal to counter-compare A register (TBCTR = CMPA).
2. CTR = CMPB: Time-base counter equal to counter-compare B register (TBCTR = CMPB).
3. CTR = CMPC: Time-base counter equal to counter-compare C register (TBCTR = CMPC). This event can be used to generate an event in the event trigger submodule only.
4. CTR = CMPD: Time-base counter equal to counter-compare D register (TBCTR = CMPD). This event can be used to generate an event in the event trigger submodule only.

For up-count or down-count mode, each event occurs only once per cycle. For up-down count mode each event occurs twice per cycle if the compare value is between 0x00-TBPRD and once per cycle if the compare value is equal to 0x00 or equal to TBPRD. These events are fed into the action-qualifier submodule where they are qualified by the counter direction and converted into actions if enabled. Refer to [Section 7.4.5.7.1](#) for more details.

The counter-compare registers CMPA and CMPB each have an associated shadow register. Shadowing provides a way to keep updates to the registers synchronized with the hardware. When shadowing is used, updates to the active registers only occur at strategic points. This prevents corruption or spurious operation due to the register being asynchronously modified by software. The memory address of the active register and the shadow register is identical. The register that is written to or read from is determined by the CMPCTL[SHDWAMODE] and CMPCTL[SHDWBMODE] bits. These bits enable and disable the CMPC shadow register and CMPD shadow register, respectively. The behavior of the two load modes is:

Shadow Mode:

The shadow mode for the CMPA is enabled by clearing the CMPCTL[SHDWAMODE] bit and the shadow register for CMPB is enabled by clearing the CMPCTL[SHDWBMODE] bit. Shadow mode is enabled by default for both CMPA and CMPB.

If the shadow register is enabled then the content of the shadow register is transferred to the active register on one of the following events as specified by the CMPCTL[LOADAMODE], CMPCTL[LOADBMODE], CMPCTL[LOADASYNC], and CMPCTL[LOADBSYNC] register bits:

- CTR = PRD: Time-base counter equal to the period (TBCTR = TBPRD).
- CTR = Zero: Time-base counter equal to zero (TBCTR = 0x00)
- Both CTR = PRD and CTR = Zero
- SYNC event caused by DCAEVT1 or DCBEVT1 or EPWMxSYNCl or TBCTL[SWFSYNC]
- Both SYNC event or a selection made by LOADAMODE/LOADBMODE

Only the active register contents are used by the counter-compare submodule to generate events to be sent to the action-qualifier.

Immediate Mode:

If immediate load mode is selected (that is, CMPCTL[SHDWAMODE] = 1 or CMPCTL[SHDWBMODE] = 1), then a read from or a write to the register will go directly to the active register.

Additional Comparators

The counter-compare submodule on ePWMs type 2 and later are responsible for generating two additional independent compare events based on two compare registers, which is fed to Event Trigger submodule:

1. CTR = CMPC: Time-base counter equal to counter-compare C register (TBCTR = CMPC).
2. CTR = CMPD: Time-base counter equal to counter-compare D register (TBCTR = CMPD).

The counter-compare registers CMPC and CMPD each have an associated shadow register. By default this register is shadowed. The memory address of the active register and the shadow register is identical. The value in the active CMPC and CMPD register is compared to the time-base counter (TBCTR). When the values are equal, the counter compare module generates a “time-base counter equal to counter compare C or counter compare D” event respectively. Shadowing of this register is enabled and disabled by the CMPCTL2[SHDWCMODE] and CMPCTL2[SHDWDMODE] bit. These bits enable and disable the CMPC shadow register and CMPD shadow register respectively. The behavior of the two load modes is described below:

Shadow Mode:

The shadow mode for the CMPC is enabled by clearing the CMPCTL2[SHDWCMODE] bit and the shadow register for CMPD is enabled by clearing the CMPCTL2[SHDWDMODE] bit. Shadow mode is enabled by default for both CMPC and CMPD.

If the shadow register is enabled then the content of the shadow register is transferred to the active register on one of the following events as specified by the CMPCTL2[LOADCMODE], CMPCTL2[LOADDMODE], CMPCTL2[LOADCSYNC], and CMPCTL2[LOADDSYNC] register bits:

- CTR = PRD: Time-base counter equal to the period (TBCTR = TBPRD).
- CTR = Zero: Time-base counter equal to zero (TBCTR = 0x00)
- Both CTR = PRD and CTR = Zero
- SYNC event caused by DCAEVT1 or DCBEVT1 or EPWMxSYNCl or TBCTL[SWFSYNC]
- Both SYNC event or a selection made by LOADCMODE/LOADDMODE

Only the active register contents are used by the counter-compare submodule to generate events to be sent to the action-qualifier.

Immediate Load Mode:

If the immediate load mode is selected (that is, CMPCTL2[SHDWCMODE] = 1 or CMPCTL2[SHDWDMODE] = 1), then a read from or a write to the register will go directly to the active register.

Global Load Support

The global load control mechanism can also be used for all counter-compare registers by configuring the appropriate bits in the global load configuration register (GLDCFG). When the global load mode is selected the transfer of contents from shadow register to active register, for all registers that have this mode enabled, occurs at the same event as defined by the configuration bits in the Global Shadow to Active Load Control Register (GLDCTL). The global load control mechanism is explained in [Section 7.4.5.5.8](#).

7.4.5.6.4 Count Mode Timing Waveforms

The counter-compare module can generate compare events in all three count modes:

- Up-count mode: used to generate an asymmetrical PWM waveform.
- Down-count mode: used to generate an asymmetrical PWM waveform.
- Up-down-count mode: used to generate a symmetrical PWM waveform.

To best illustrate the operation of the first three modes, the timing diagrams in [Figure 7-128](#) through [Figure 7-131](#) show when events are generated and how the EPWMxSYNCl signal interacts.

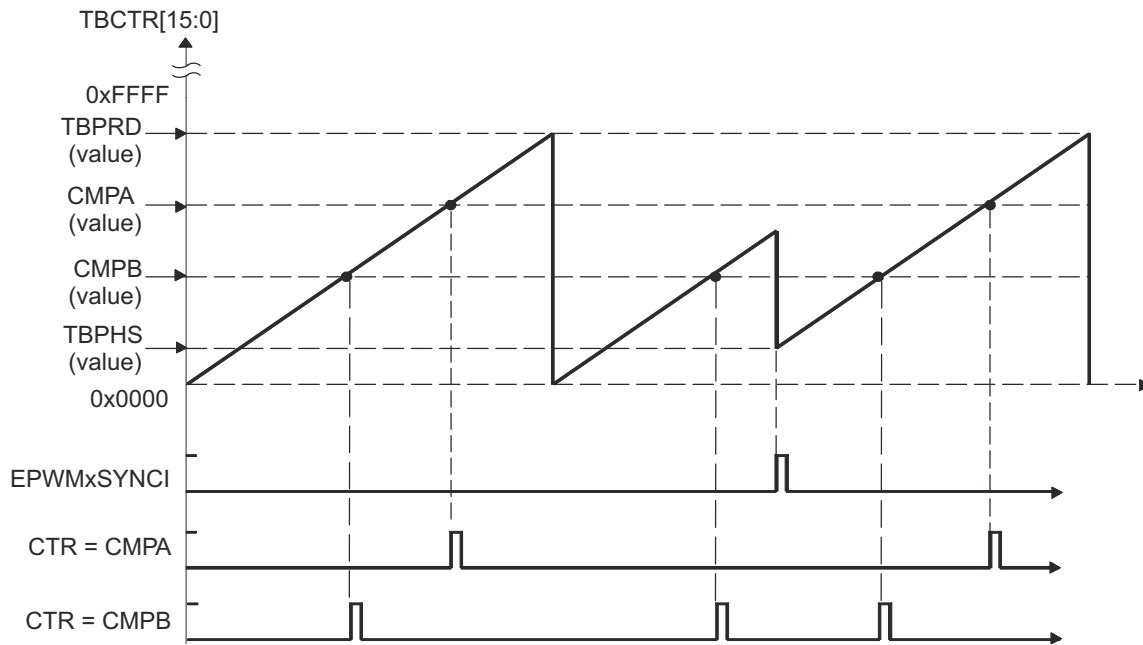

An EPWMxSYNCl external synchronization event can cause a discontinuity in the TBCTR count sequence. This can lead to a compare event being skipped. This skipping is considered normal operation and must be taken into account.

Figure 7-128. Counter-Compare Event Waveforms in Up-Count Mode

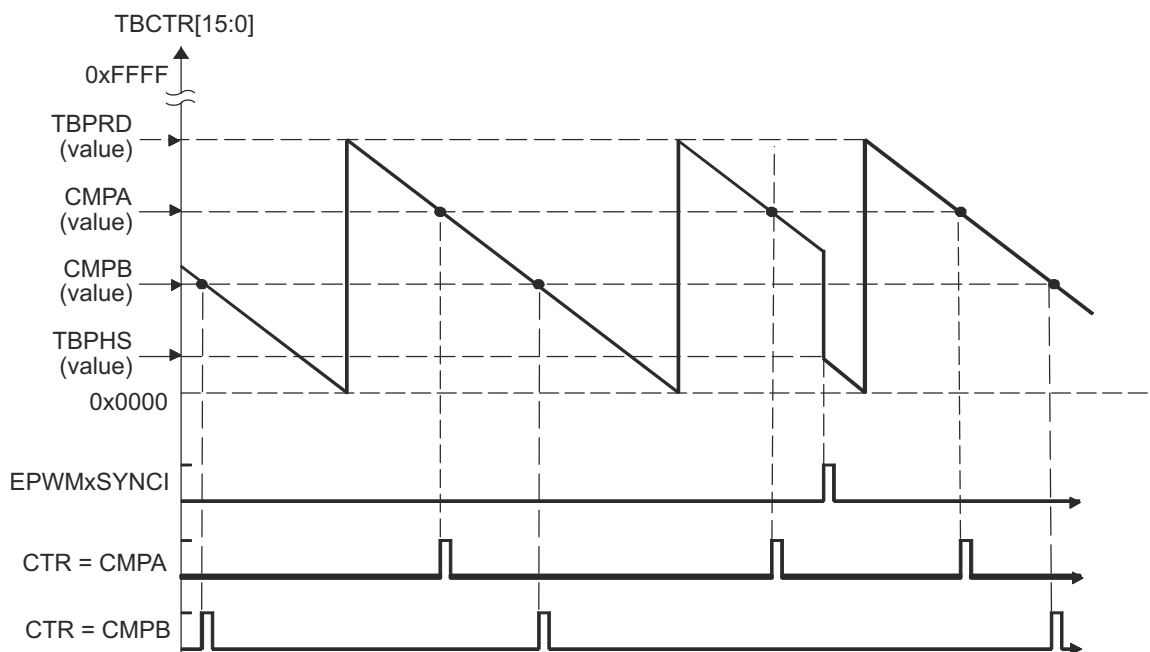

Figure 7-129. Counter-Compare Events in Down-Count Mode

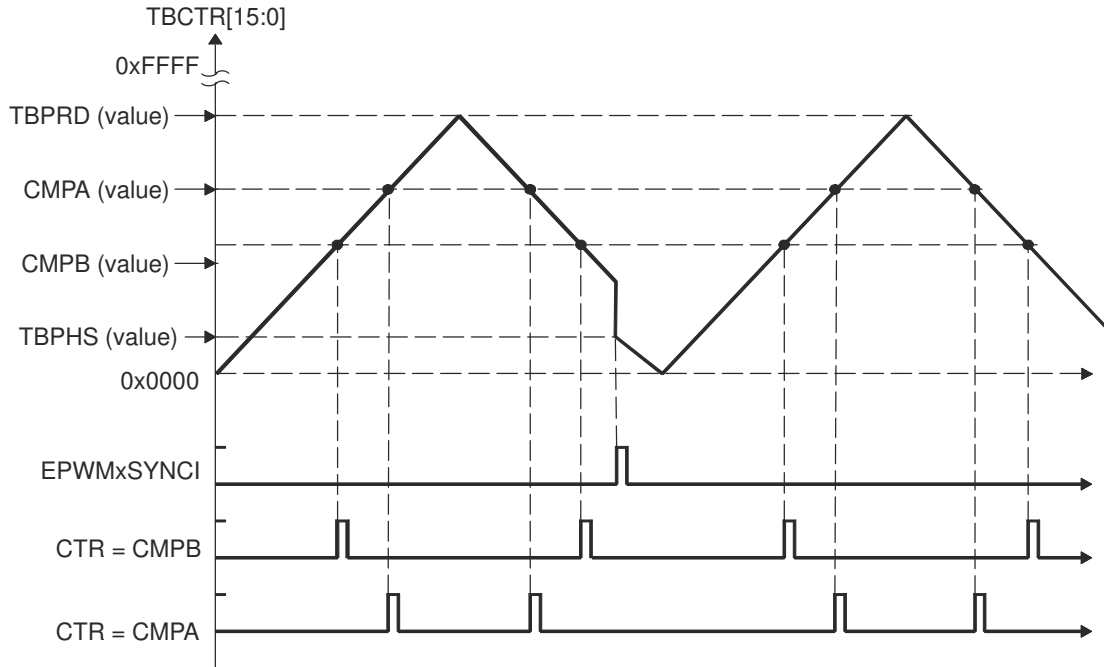

Figure 7-130. Counter-Compare Events In Up-Down-Count Mode, TBCTL[PHSDIR = 0] Count Down On Synchronization Event

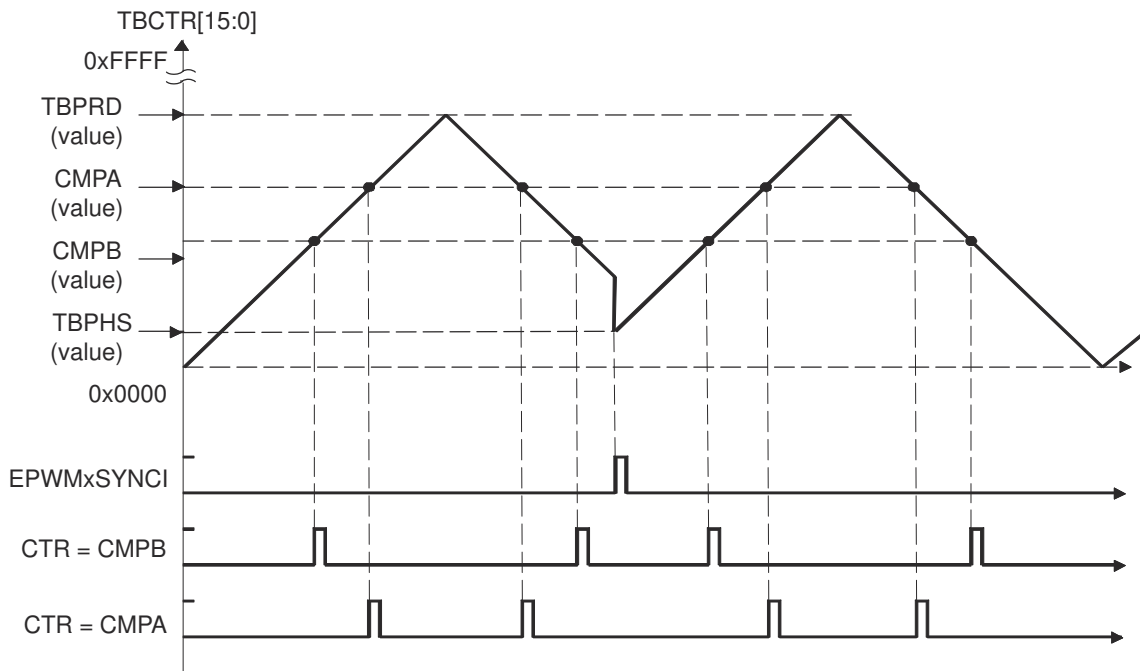

Figure 7-131. Counter-Compare Events In Up-Down-Count Mode, TBCTL[PHSDIR = 1] Count Up On Synchronization Event

7.4.5.7 Action-Qualifier (AQ) Submodule

The action-qualifier submodule has the most important role in waveform construction and PWM generation. It decides which events are converted into various action types, thereby producing the required switched waveforms at the EPWMxA and EPWMxB outputs.

7.4.5.7.1 Purpose of the Action-Qualifier Submodule

The action-qualifier submodule is responsible for the following:

- Qualifying and generating actions (set, clear, toggle) based on the following events:
 - CTR = PRD: Time-base counter equal to the period (TBCTR = TBPRD).
 - CTR = Zero: Time-base counter equal to zero (TBCTR = 0x00)
 - CTR = CMPA: Time-base counter equal to the counter-compare A register (TBCTR = CMPA)
 - CTR = CMPB: Time-base counter equal to the counter-compare B register (TBCTR = CMPB)
- T1, T2 events: Trigger events based on comparator, trip or syncin events
- Managing priority when these events occur concurrently
- Providing independent control of events when the time-base counter is increasing and when it is decreasing

7.4.5.7.2 Action-Qualifier Submodule Control and Status Register Definitions

The action-qualifier submodule operation is shown in Figure 7-132 and monitored by way of the registers in .

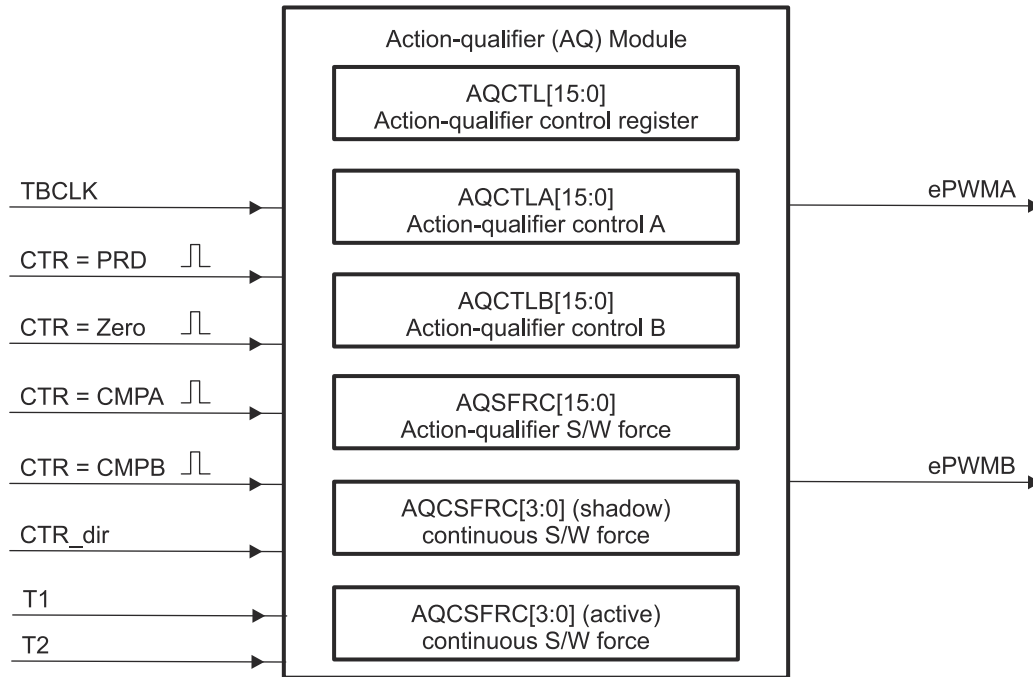

Figure 7-132. Action-Qualifier Submodule Inputs and Outputs

For convenience, the possible input events are summarized again in Table 7-110.

Table 7-110. Action-Qualifier Submodule Possible Input Events

Signal	Description	Registers Compared
CTR = PRD	Time-base counter equal to the period value	TBCTR = TBPRD
CTR = Zero	Time-base counter equal to zero	TBCTR = 0x00
CTR = CMPA	Time-base counter equal to the counter-compare A	TBCTR = CMPA
CTR = CMPB	Time-base counter equal to the counter-compare B	TBCTR = CMPB
T1 event	Based on comparator, trip or syncin events	None
T2 event	Based on comparator, trip or syncin events	None
Software forced event	Asynchronous event initiated by software	

The software forced action is a useful asynchronous event. This control is handled by the AQSFRC and AQCSFRC registers.

Note

If the CSFA is not used in shadow mode, the RLDCSF bit must be configured to disable shadow mode.

The action-qualifier submodule controls how the two outputs EPWMxA and EPWMxB behave when a particular event occurs. The event inputs to the action-qualifier submodule are further qualified by the counter direction (up or down). This allows for independent action on outputs on both the count-up and count-down phases.

The possible actions imposed on outputs EPWMxA and EPWMxB are:

- **Set High:**
Set output EPWMxA or EPWMxB to a high level.
- **Clear Low:**
Set output EPWMxA or EPWMxB to a low level.
- **Toggle:**
If EPWMxA or EPWMxB is currently pulled high, then pull the output low. If EPWMxA or EPWMxB is currently pulled low, then pull the output high.
- **Do Nothing:**
Keep outputs EPWMxA and EPWMxB at same level as currently set. Although the "Do Nothing" option prevents an event from causing an action on the EPWMxA and EPWMxB outputs, this event can still trigger interrupts and ADC start of conversion. See the description in [Section 7.4.5.11](#) for details.

Actions are specified independently for either output (EPWMxA or EPWMxB). Any or all events can be configured to generate actions on a given output. For example, both CTR = CMPA and CTR = CMPB can operate on output EPWMxA. All qualifier actions are configured via the control registers found at the end of this section.

For clarity, the illustrations in this chapter use a set of symbolic actions. These symbols are summarized in [Figure 7-133](#). Each symbol represents an action as a marker in time. Some actions are fixed in time (zero and period) while the CMPA and CMPB actions are moveable and their time positions are programmed by way of the counter-compare A and B registers, respectively. To turn off or disable an action, use the "Do Nothing option"; it is the default at reset.





























SW force	TB Counter equals				Trigger Events		Actions
	Zero	Comp A	Comp B	Period	T1	T2	
							Do Nothing
							Clear Lo
							Set Hi
							Toggle

Figure 7-133. Possible Action-Qualifier Actions for EPWMxA and EPWMxB Outputs

The Action Qualifier Trigger Event Source Selection register (AQTSRCSEL) is used to select the source for T1 and T2 events. T1/T2 selection and configuration of a trip/digital-compare event in Action Qualifier submodule is independent of the configuration of that event in the Trip-Zone submodule. A particular trip event may or may not be configured to cause trip action in the Trip Zone submodule, but the same event can be used by the Action Qualifier to generate T1/T2 for controlling PWM generation.

7.4.5.7.3 Action-Qualifier Event Priority

It is possible for the ePWM action qualifier to receive more than one event at the same time. In this case events are assigned a priority by the hardware. The general rule is events occurring later in time have a higher priority and software forced events always have the highest priority. The event priority levels for up-down-count mode are shown in [Table 7-111](#). A priority level of 1 is the highest priority and level 10 is the lowest. The priority changes slightly depending on the direction of TBCTR.

Table 7-111. Action-Qualifier Event Priority for Up-Down-Count Mode

Priority Level	Event If TBCTR is Incrementing TBCTR = Zero up to TBCTR = TBPRD	Event If TBCTR is Decrementing TBCTR = TBPRD down to TBCTR = 1
1 (Highest)	Software forced event	Software forced event
2	T1 on up-count (T1U)	T1 on down-count (T1D)
3	T2 on up-count (T2U)	T2 on down-count (T2D)
4	Counter equals CMPB on up-count (CBU)	Counter equals CMPB on down-count (CBD)
5	Counter equals CMPA on up-count (CAU)	Counter equals CMPA on down-count (CAD)
6	Counter equals zero	Counter equals period (TBPRD)
7	T1 on down-count (T1D)	T1 on up-count (T1U)
8	T2 on down-count (T2D)	T2 on up-count (T2U)
9	Counter equals CMPB on down-count (CBD)	Counter equals CMPB on up-count (CBU)
10 (Lowest)	Counter equals CMPA on down-count (CAD)	Counter equals CMPA on up-count (CBU)

[Table 7-112](#) shows the action-qualifier priority for up-count mode. In this case, the counter direction is always defined as up and therefore, down-count events will never be taken.

Table 7-112. Action-Qualifier Event Priority for Up-Count Mode

Priority Level	Event
1 (Highest)	Software forced event
2	Counter equal to period (TBPRD)
3	T1 on up-count (T1U)
4	T2 on up-count (T2U)
5	Counter equal to CMPB on up-count (CBU)
6	Counter equal to CMPA on up-count (CAU)
7 (Lowest)	Counter equal to Zero

[Table 7-113](#) shows the action-qualifier priority for down-count mode. In this case, the counter direction is always defined as down and thus up-count events will never be taken.

Table 7-113. Action-Qualifier Event Priority for Down-Count Mode

Priority Level	Event
1 (Highest)	Software forced event
2	Counter equal to Zero
3	T1 on down-count (T1D)
4	T2 on down-count (T2D)
5	Counter equal to CMPB on down-count (CBD)
6	Counter equal to CMPA on down-count (CAD)
7 (Lowest)	Counter equal to period (TBPRD)

It is possible to set the compare value greater than the period. In this case the action will take place as shown in [Table 7-114](#).

Table 7-114. Behavior if CMPA/CMPB is Greater than the Period

Counter Mode	Compare on Up-Count Event CAD/CBD	Compare on Down-Count Event CAD/CBD
Up-Count Mode	If $CMPA/CMPB \leq TBPRD$ period, then the event occurs on a compare match (TBCTR=CMPA or CMPB). If $CMPA/CMPB > TBPRD$, then the event will not occur.	Never occurs.
Down-Count Mode	Never occurs.	If $CMPA/CMPB < TBPRD$, the event will occur on a compare match (TBCTR=CMPA or CMPB). If $CMPA/CMPB \geq TBPRD$, the event will occur on a period match (TBCTR=TBPRD).
Up-Down-Count Mode	If $CMPA/CMPB < TBPRD$ and the counter is incrementing, the event occurs on a compare match (TBCTR=CMPA or CMPB). If $CMPA/CMPB \geq TBPRD$, the event will occur on a period match (TBCTR = TBPRD).	If $CMPA/CMPB < TBPRD$ and the counter is decrementing, the event occurs on a compare match (TBCTR=CMPA or CMPB). If $CMPA/CMPB \geq TBPRD$, the event occurs on a period match (TBCTR=TBPRD).

7.4.5.7.4 AQCTLA and AQCTLB Shadow Mode Operations

To enable Action Qualifier mode changes which must occur at the end of a period even when the phase changes, shadowing of the AQCTLA and AQCTLB registers has been added on ePWMs type 2 and later. Additionally, shadow to active load on SYNC of these registers is supported as well. Shadowing of this register is enabled and disabled by the AQCTL[SHDWAQAMODE] and AQCTL[SHDWAQBMODE] bits. These bits enable and disable the AQCTLA shadow register and AQCTLB shadow register, respectively. The behavior of the two load modes is:

Shadow Mode

The shadow mode for the AQCTLA is enabled by setting the AQCTL[SHDWAQAMODE] bit, and the shadow register for AQCTLB is enabled by setting the AQCTL[SHDWAQBMODE] bit. Shadow mode is disabled by default for both AQCTLA and AQCTLB

If the shadow register is enabled, then the content of the shadow register is transferred to the active register on one of the following events as specified by the AQCTL[LDAQAMODE], AQCTL[LDAQBMODE], AQCTL[LDAQASYNC], and AQCTL[LDAQBSYNC] register bits:

- CTR = PRD: Time-base counter equal to the period (TBCTR = TBPRD).
- CTR = Zero: Time-base counter equal to zero (TBCTR = 0x00)
- Both CTR = PRD and CTR = Zero
- SYNC event caused by DCAEVT1 or DCBEVT1 or EPWMxSYNCl or TBCTL[SWFSYNC]
- Both SYNC event or a selection made by LDAQAMODE/LDAQBMODE

Global Load Support

Global load control mechanism can also be used for AQCTLA:AQCTLA2, AQCTLB:AQCTLB2, and AQCSFRC registers by configuring the appropriate bits in the global load configuration register (GLDCFG). When global load mode is selected, the transfer of contents from shadow register to active register for all registers that have this mode enabled, occurs at the same event as defined by the configuration bits in the Global Shadow to Active Load Control Register (GLDCTL). The global load control mechanism is explained in [Section 7.4.5.5.8](#).

Immediate Load Mode

If immediate load mode is selected (that is, AQCTL[SHDWAQAMODE] = 0 or AQCTL[SHDWAQBMODE] = 0), then a read from or a write to the register will go directly to the active register. See [Figure 7-134](#) and [Figure 7-135](#).

Note

Shadow to Active Load of Action Qualifier Output A/B Control Register [AQCTLA and AQCTLB] on CMPA = 0 or CMPB = 0 boundary

If the Counter-Compare A Register (CMPA) or Counter-Compare B Register (CMPB) is set to a value of 0 and the action qualifier action on AQCTLA and AQCTLB is configured to occur in the same instant as a shadow to active load (that is, CMPA=0 and AQCTLA shadow to active load on TBCTR=0 using AQCTL register LDAQAMODE and LDAQAMODE bits), then both events enter contention and it is recommended to use a Non-Zero Counter-Compare when using Shadow to Active Load of Action Qualifier Output A/B Control Register on TBCTR = 0 boundary.

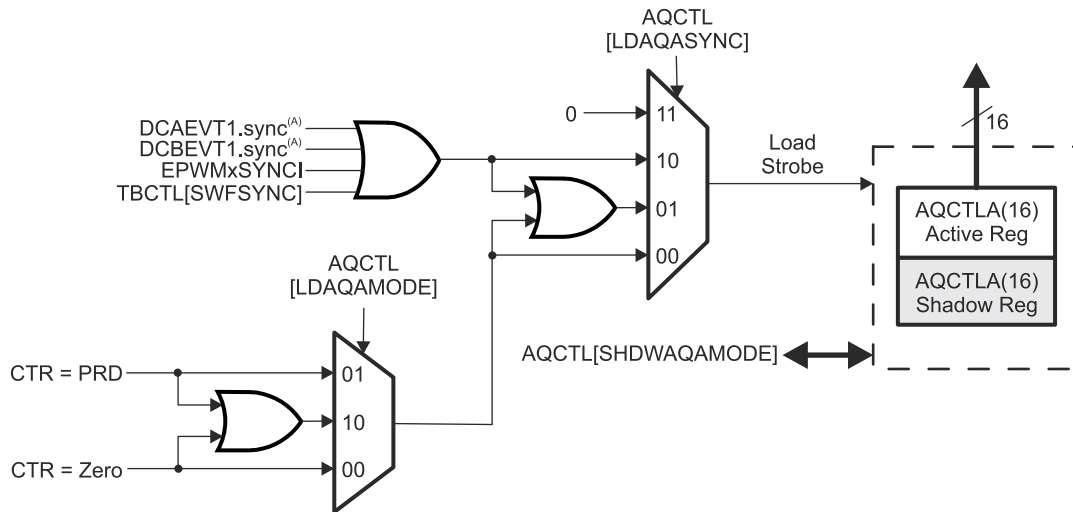

- A. These events are generated by the ePWM digital compare (DC) submodule based on the levels of the TRIPIN inputs (for example, CMPSSx and TZ signals).

Figure 7-134. AQCTL[SHDWAQAMODE]

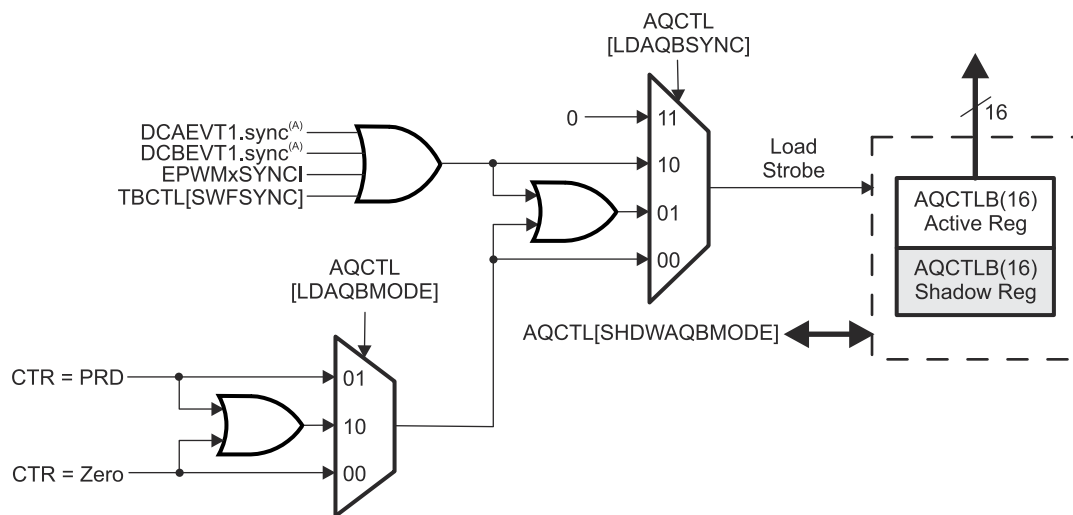

- A. These events are generated by the ePWM digital compare (DC) submodule based on the levels of the TRIPIN inputs (for example, CMPSSx and TZ signals).

Figure 7-135. AQCTL[SHDWAQBMODE]

7.4.5.7.5 Waveforms for Common Configurations

Note

The waveforms in this document show the behavior of the ePWMs for a static compare register value. In a running system, the active compare registers (CMPA and CMPB) are typically updated from their respective shadow registers once every period. You specify when the update takes place: either when the time-base counter reaches zero or when the time-base counter reaches the period. There are some cases when the action based on the new value can be delayed by one period or the action based on the old value can take effect for an extra period. Some PWM configurations avoid this situation. These include, but are not limited to, the following:

Use up-down-count mode to generate a symmetric PWM:

- If you load CMPA/CMPB on zero, then use CMPA/CMPB values greater than or equal to 1.
- If you load CMPA/CMPB on period, then use CMPA/CMPB values less than or equal to TBPRD-1.

This means there are always be a pulse of at least one TBCLK cycle in a PWM period which, when very short, tend to be ignored by the system.

Use up-down-count mode to generate an asymmetric PWM:

- To achieve 50%-0% asymmetric PWM use the following configuration: Load CMPA/CMPB on period and use the period action to clear the PWM and a compare-up action to set the PWM. Modulate the compare value from 0 to TBPRD to achieve 50%-0% PWM duty.

When using up-count mode to generate an asymmetric PWM:

- To achieve 0-100% asymmetric PWM use the following configuration: Load CMPA/CMPB on TBPRD. Use the Zero action to set the PWM and a compare-up action to clear the PWM. Modulate the compare value from 0 to TBPRD+1 to achieve 0-100% PWM duty.

When using up-count mode to generate an asymmetric PWM with deadband enabled:

- To achieve 0%-100% PWM use the following configuration: When the CMPA value is too close to 0 or PRD such that the following conditions are met ($CMPX < Deadband$) or ($CMPX > PRD - Deadband$), the actions specified by the AQCTL register for CMPX do not take effect. To avoid this, the AQCTL settings have to be altered under these conditions only to generate either high or low pulses for both CAU or CAD events (both set or both clear). Make sure that this software update is occurring synchronous to the PWM carrier cycle, and shadow mode is enabled.

When using up-down-count mode to generate an asymmetric PWM with deadband enabled:

- To achieve 0%-100% PWM use the following configuration: When the CMPA value is too close to 0 or PRD such that the following conditions are met ($CMPX < Deadband/2$) or ($CMPX > PRD - (Deadband)/2$), the actions specified by the AQCTL register for CMPX do not take effect. To avoid this, the AQCTL settings have to be altered under these conditions only to generate either high or low pulses for both CAU or CAD events (both set or both clear). Make sure that this software update is occurring synchronous to the PWM carrier cycle, and shadow mode is enabled.

See [Using Enhanced Pulse Width Modulator \(ePWM\) Module for 0-100% Duty Cycle Control](#).

Figure 7-136 shows how a symmetric PWM waveform can be generated using the up-down-count mode of the TBCTR. In this mode, 0%-100% DC modulation is achieved by using equal compare matches on the up count and down count portions of the waveform. In the example shown, CMPA is used to make the comparison. When the counter is incrementing, the CMPA match pulls the PWM output high. Likewise when the counter is decrementing, the compare match pulls the PWM signal low. When $CMPA = 0$, the PWM signal is high for the entire period giving a 100% duty waveform. When $CMPA = TBPRD$, the PWM signal is low achieving 0% duty.

When using this configuration in practice, if you load CMPA/CMPB on zero, then use CMPA/CMPB values greater than or equal to 1. If you load CMPA/CMPB on period, then use CMPA/CMPB values less than or equal to TBPRD-1. This means there is always a pulse of at least one TBCLK cycle in a PWM period which, when very short, tend to be ignored by the system.

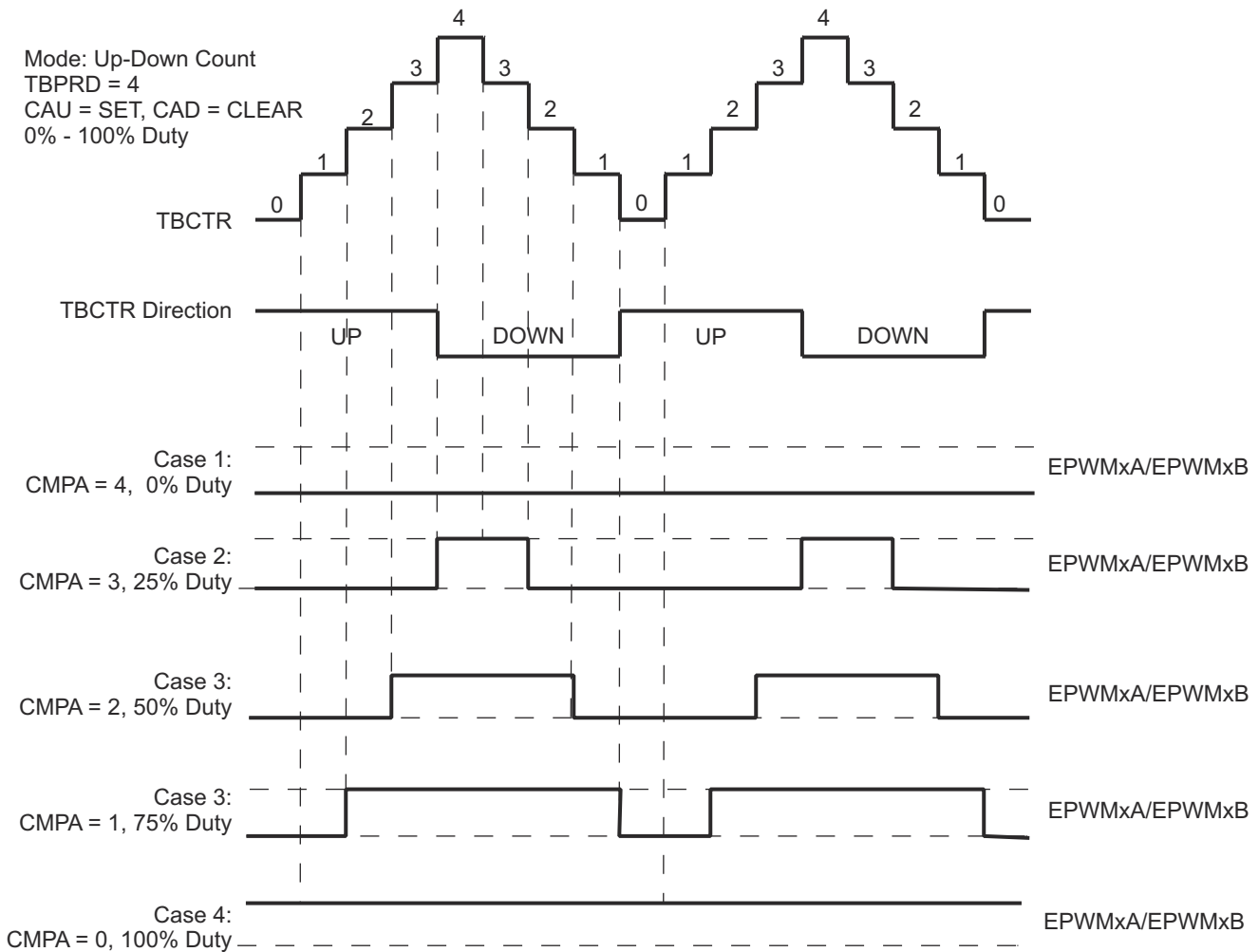
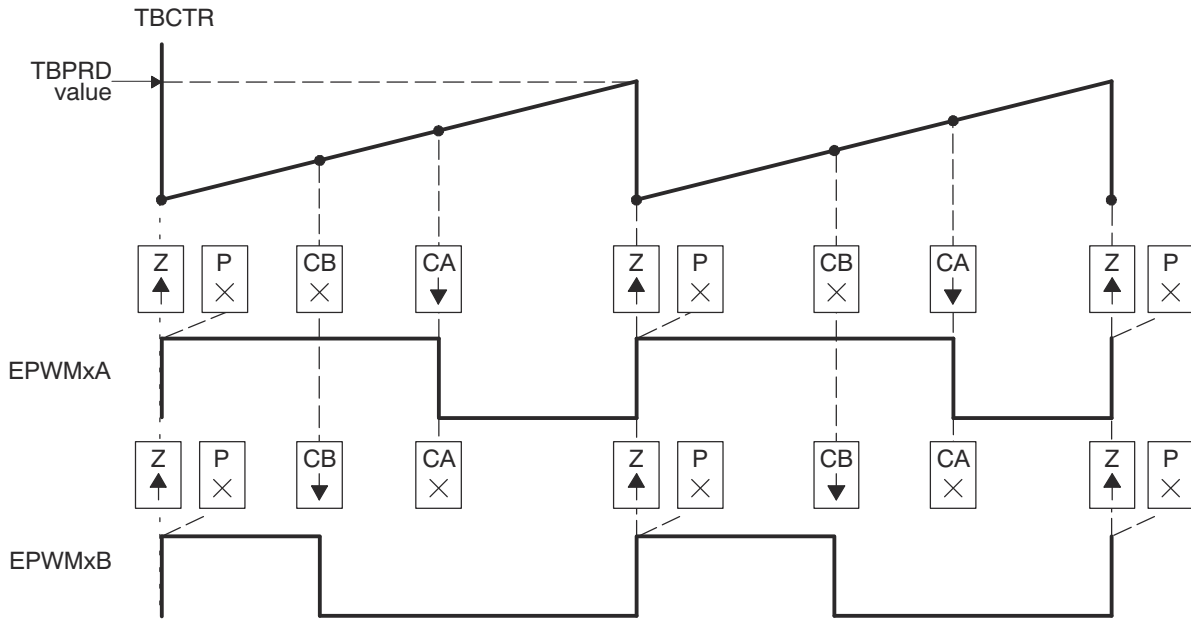

Figure 7-136. Up-Down-Count Mode Symmetrical Waveform

The PWM waveforms in [Figure 7-137](#) through [Figure 7-142](#) show some common action-qualifier configurations. Some conventions used in the figures and examples are as follows:

- TBPRD, CMPA, and CMPB refer to the value written in their respective registers. The active register, not the shadow register, is used by the hardware.
- CMPx, refers to either CMPA or CMPB.
- EPWMxA and EPWMxB refer to the output signals from ePWMx
- Up-Down means Count-up-and-down mode, Up means up-count mode and Dwn means down-count mode
- Sym = Symmetric, Asym = Asymmetric



- A. $PWM\ period = (TBPRD + 1) \times T_{TBCLK}$
- B. Duty modulation for EPWMxA is set by CMPA, and is active high (that is, high time duty proportional to CMPA).
- C. Duty modulation for EPWMxB is set by CMPB and is active high (that is, high time duty proportional to CMPB).
- D. The "Do Nothing" actions (X) are shown for completeness, but are not shown on subsequent diagrams.
- E. Actions at zero and period, although appearing to occur concurrently, are actually separated by one TBCLK period. TBCTR wraps from period to 0000.

Figure 7-137. Up, Single Edge Asymmetric Waveform, With Independent Modulation on EPWMxA and EPWMxB—Active High

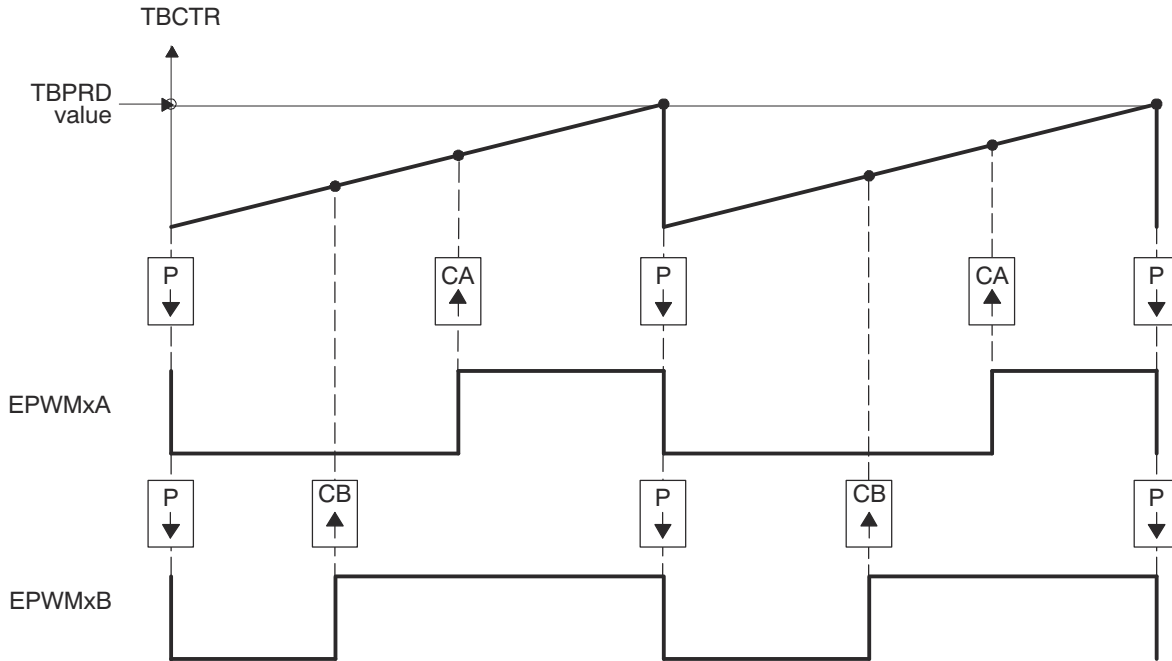

- A. $PWM\ period = (TBPRD + 1) \times T_{TBCLK}$
- B. Duty modulation for EPWMxA is set by CMPA, and is active low (that is, the low time duty is proportional to CMPA).
- C. Duty modulation for EPWMxB is set by CMPB and is active low (that is, the low time duty is proportional to CMPB).
- D. Actions at zero and period, although appearing to occur concurrently, are actually separated by one TBCLK period. TBCTR wraps from period to 0000.

Figure 7-138. Up, Single Edge Asymmetric Waveform With Independent Modulation on EPWMxA and EPWMxB—Active Low

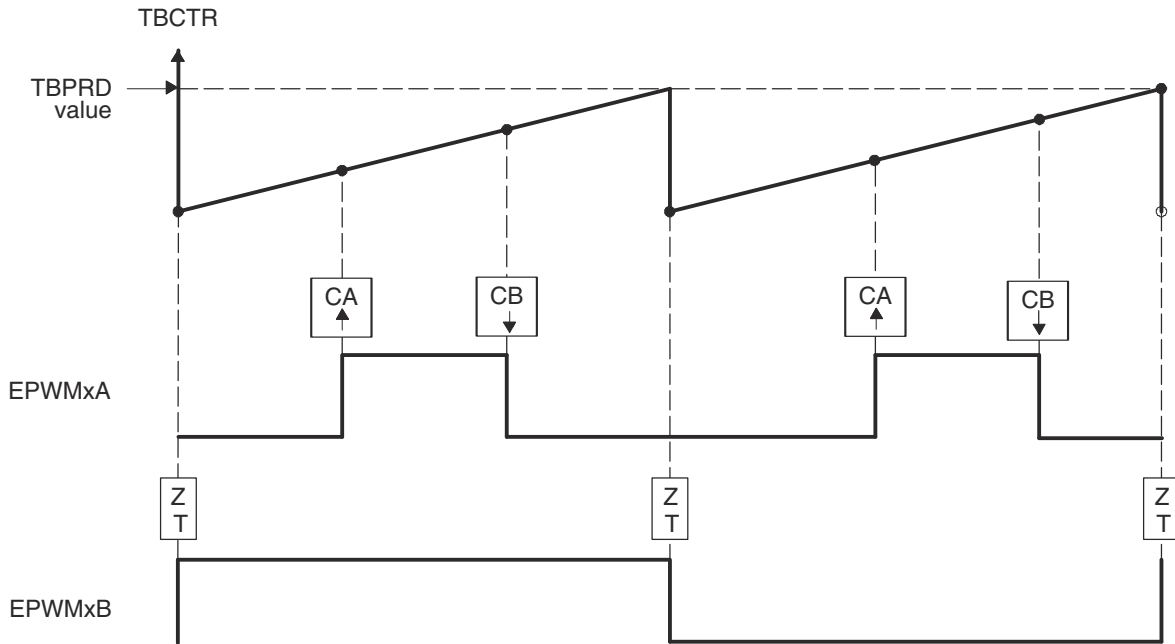

- A. $PWM\ frequency = 1 / ((TBPRD + 1) \times T_{TBCLK})$
- B. Pulse can be placed anywhere within the PWM cycle (0000 - TBPRD)
- C. High time duty proportional to (CMPB - CMPA)

Figure 7-139. Up-Count, Pulse Placement Asymmetric Waveform With Independent Modulation on EPWMxA

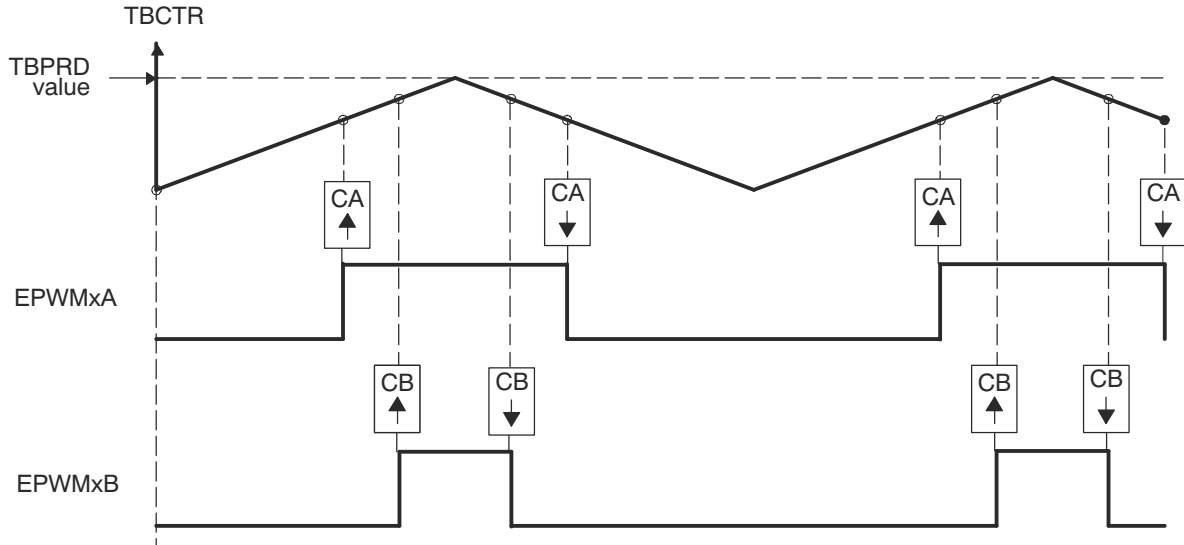

- A. $PWM\ period = 2 \times TBPRD \times T_{TBCLK}$
- B. Duty modulation for EPWMxA is set by CMPA, and is active low (that is, the low time duty is proportional to CMPA).
- C. Duty modulation for EPWMxB is set by CMPB and is active low (that is, the low time duty is proportional to CMPB).
- D. Outputs EPWMxA and EPWMxB can drive independent power switches.

Figure 7-140. Up-Down-Count, Dual Edge Symmetric Waveform, With Independent Modulation on EPWMxA and EPWMxB — Active Low

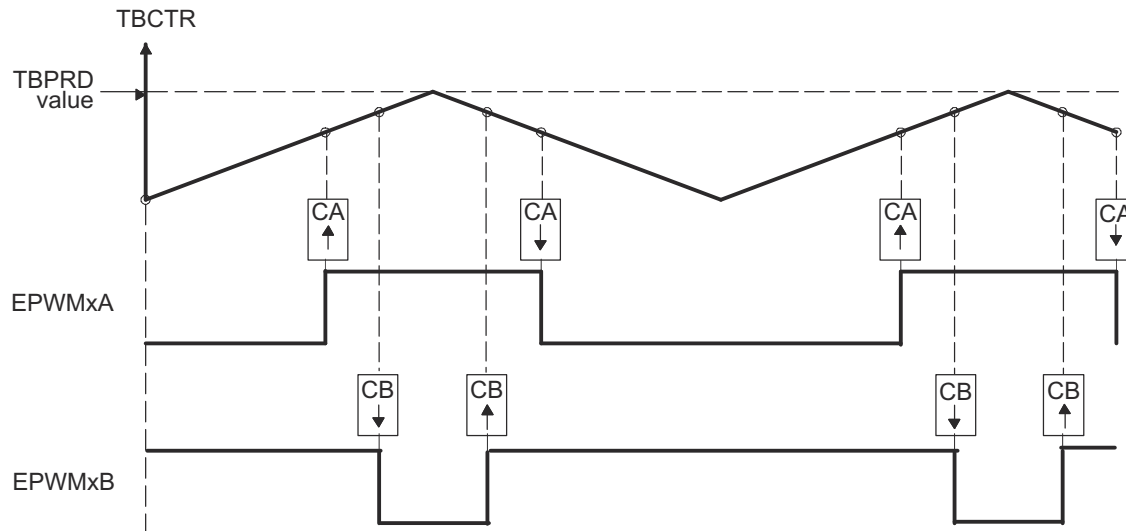

- A. $\text{PWM period} = 2 \times \text{TBPRD} \times T_{\text{TBCLK}}$
- B. Duty modulation for EPWMxA is set by CMPA, and is active low, that is, low time duty proportional to CMPA.
- C. Duty modulation for EPWMxB is set by CMPB and is active high, that is, high time duty proportional to CMPB.
- D. Outputs EPWMx can drive upper/lower (complementary) power switches.
- E. Dead-band = $\text{CMPB} - \text{CMPA}$ (fully programmable edge placement by software). Note the dead-band module is also available if the more classical edge delay method is required.

Figure 7-141. Up-Down-Count, Dual Edge Symmetric Waveform, With Independent Modulation on EPWMxA and EPWMxB — Complementary

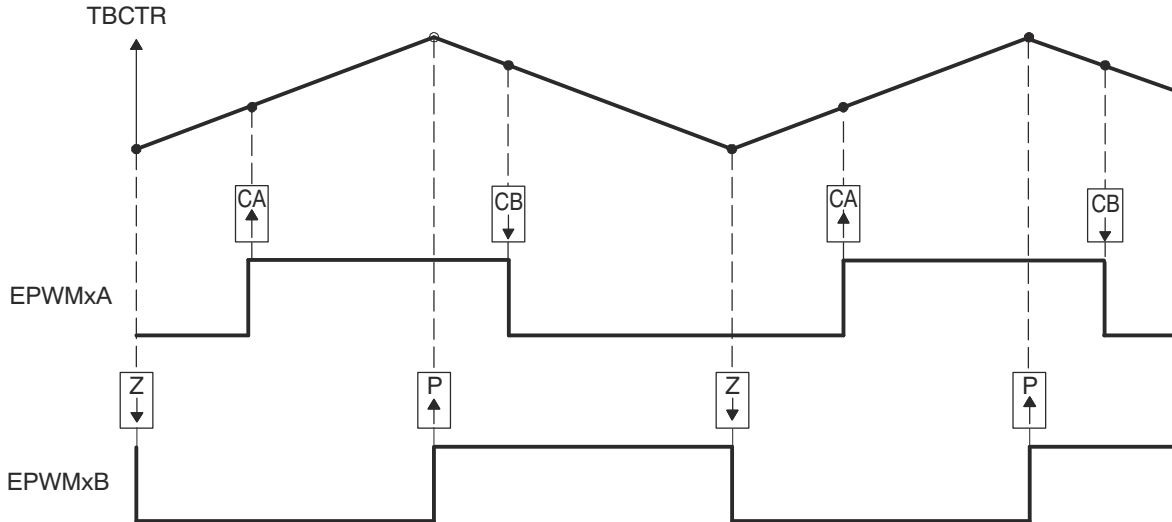

- A. PWM period = $2 \times \text{TBPRD} \times \text{TBCLK}$
- B. Rising edge and falling edge can be asymmetrically positioned within a PWM cycle. This allows for pulse placement techniques.
- C. Duty modulation for EPWMxA is set by CMPA and CMPB.
- D. Low time duty for EPWMxA is proportional to $(\text{CMPA} + \text{CMPB})$.
- E. To change this example to active high, CMPA and CMPB actions need to be inverted (that is, Clear on CMPA, Set on CMPB).
- F. Duty modulation for EPWMxB is fixed at 50% (utilizes spare action resources for EPWMxB).

Figure 7-142. Up-Down-Count, Dual Edge Asymmetric Waveform, With Independent Modulation on EPWMxA—Active Low

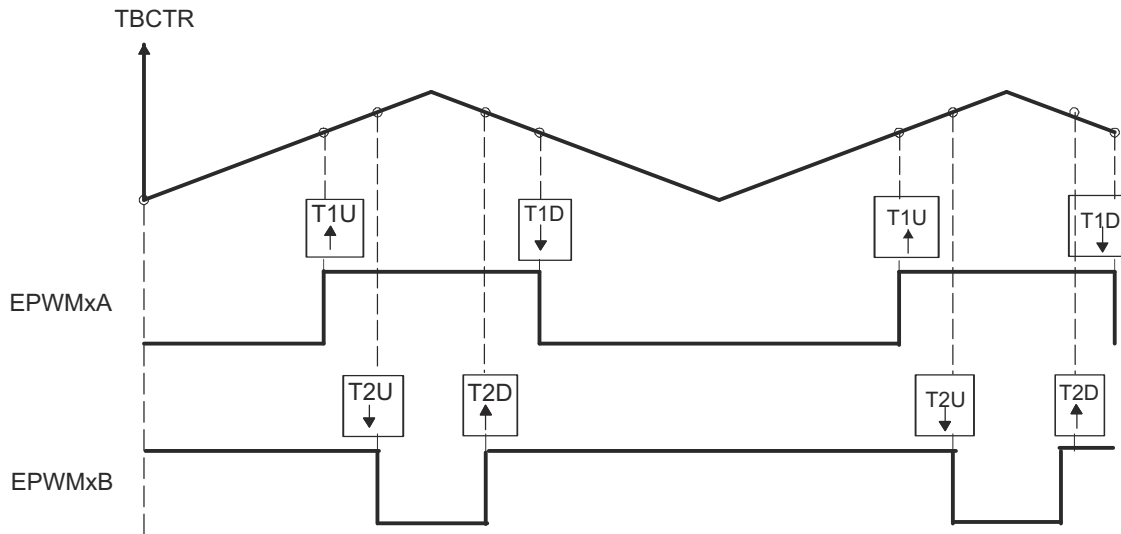

- A. $PWM\ period = 2 \times TBPRD \times TTCLK$
- B. Independent T1 event actions when counter is counting up and when the counter is counting down are used to generate EPWMxA output.
- C. Independent T2 event actions when counter is counting up and when the counter is counting down are used to generate EPWMxB output.
- D. TZ1 is selected as the source for T1.
- E. TZ2 is selected as the source for T2.

Figure 7-143. Up-Down-Count, PWM Waveform Generation Utilizing T1 and T2 Events

7.4.5.8 Dead-Band Generator (DB) Submodule

7.4.5.8.1 Purpose of the Dead-Band Submodule

The action-qualifier (AQ) module section discussed how it is possible to generate the required dead band by having full control over edge placement using both the CMPA and CMPB resources of the ePWM module. However, if the more classical edge delay-based dead band with polarity control is required, then the dead-band submodule described here should be used.

The key functions of the dead-band module are:

- Generating appropriate signal pairs (EPWMxA and EPWMxB) with dead-band relationship from a single EPWMxA input
- Programming signal pairs for:
 - Active high (AH)
 - Active low (AL)
 - Active high complementary (AHC)
 - Active low complementary (ALC)
- Adding programmable delay to rising edges (RED)
- Adding programmable delay to falling edges (FED)
- Can be totally bypassed from the signal path (note dotted lines in diagram)

7.4.5.8.2 Dead-band Submodule Additional Operating Modes

On type 1 ePWM RED could appear on one channel output and FED could appear on the other channel output.

The following list shows the distinct difference between type 1 and type 4 modules with respect to dead-band operating modes:

- By adding S6, S7, and S8 in [Figure 7-144](#), RED and FED can appear on both the A-channel and B-channel outputs. Additionally, both RED and FED together can be applied to either the A-channel or B-channel outputs to allow B-channel phase shifting with respect to the A-channel.

Note

Phase shifting B-channel with respect to the A-channel using the dead-band submodule additional operating modes has limitations with respect to the choice of RED and FED delay with respect to the operating duty cycle of the ePWMxA and ePWMxB outputs.

- The dead-band counters have also been increased to 14 bits
- Dead-band and dead-band High-resolution registers are now shadowed
- High-resolution dead-band RED and FED have been enabled using the DBREDHR and DBFEDHR registers

Note

The PWM chopper will not be enabled when high-resolution dead band is enabled.

High-resolution dead-band RED and FED requires Half-Cycle clocking mode (DBCTL[HALFCYCLE] = 1).

Cannot have both RED and FED together applied to both ePWMxA and ePWMxB. RED and FED together can be applied only to either OutA OR OutB.

Phase shifting B-channel with respect to the A-channel: When PWMxB is derived from PWMxA using the DEDB_MODE bit and by delaying rising edge and falling edge by the phase shift amount. When the duty cycle value on PWMxA is less than this phase shift amount, PWMxA's falling edge has precedence over the delayed rising edge for PWMxB. It is recommended to make sure the duty cycle value of the current waveform fed to the dead-band module is greater than the required phase shift amount.

The Type 4 action qualifier and dead-band outputs of the ePWM module are delayed by one TBCLK cycle in comparison to the Type 2 ePWM module, although the Type 4 behavior is the same as the Type 3 PWM. Both PWMA and PWMB signals are delayed under all circumstances.

Shadow Mode

The shadow mode for the DBRED is enabled by setting the DBCTL[SHDWDBREDDMODE] bit and the shadow register for DBFED is enabled by setting the DBCTL [SHDWDBFEDMODE] bit. Shadow mode is disabled by default for both DBRED and DBFED

If the shadow register is enabled, then the content of the shadow register is transferred to the active register on one of the following events as specified by the DBCTL [LOADREDDMODE] and DBCTL [LOADFEDMODE] register bits:

- CTR = PRD: Time-base counter equal to the period (TBCTR = TBPRD).
- CTR = Zero: Time-base counter equal to zero (TBCTR = 0x00)
- Both CTR = PRD and CTR = Zero

The DBCTL register can be shadowed. The shadow mode for DBCTL is enabled by setting the DBCTL2[SHDWDBCTLMODE] bit. If the shadow register is enabled then the content of the shadow register is transferred to the active register on one of the following events as specified by the DBCTL2[LOADDBCTLMODE] register bit:

- CTR = PRD: Time-base counter equal to the period (TBCTR = TBPRD)
- CTR = Zero: Time-base counter equal to zero (TBCTR = 0x00)
- Both CTR = PRD and CTR = Zero

Global Load Support

Global load control mechanism can also be used for DBRED:DBREDHR, DBFED:DBFEDHR, and DBCTL registers by configuring the appropriate bits in the global load configuration register (GLDCFG). When global load mode is selected the transfer of contents from shadow register to active register, for all registers that have this mode enabled, occurs at the same event as defined by the configuration bits in the Global Shadow to Active Load Control Register (GLDCTL). The Global load control mechanism is explained in [Section 7.4.5.5.8](#).

Note

When DBRED/DBFED active is loaded with a new shadow value while DB counters are counting, the new DBRED/DBFED value only affects the NEXT PWMx edge and not the current edge.

A Dead-band value of zero should not be used when the Global Shadow to Active Load is set to occur at CTR=ZERO. Similarly, a Dead-band value of PRD should not be used when the Global Shadow to Active Load is set to occur at CTR=PRD.

TBPRDHR should not be used with Global load. If high resolution period must be changed in the application, users must write to the individual period registers from an ePWM ISR (The ISR must be synchronous with the PWM switching period), where the Global Load One-Shot bit is also written to.

7.4.5.8.3 Simultaneous Writes to DBRED and DBFED Registers Between ePWM Modules (Type 5 EPWM)

Similar to the EPWMXLINK register, the register description for EPWMXLINK2 clearly explains the linked register bit-field values for corresponding ePWM. An example of using the EPWMXLINK2 is linking ePWM2 DBRED with DBRED of ePWM1. In this case, a write to DBRED of ePWM1 will also change the DBRED value for ePWM2.

7.4.5.8.4 Operational Highlights for the Dead-Band Submodule

The configuration options for the dead-band submodule are shown in [Figure 7-144](#).

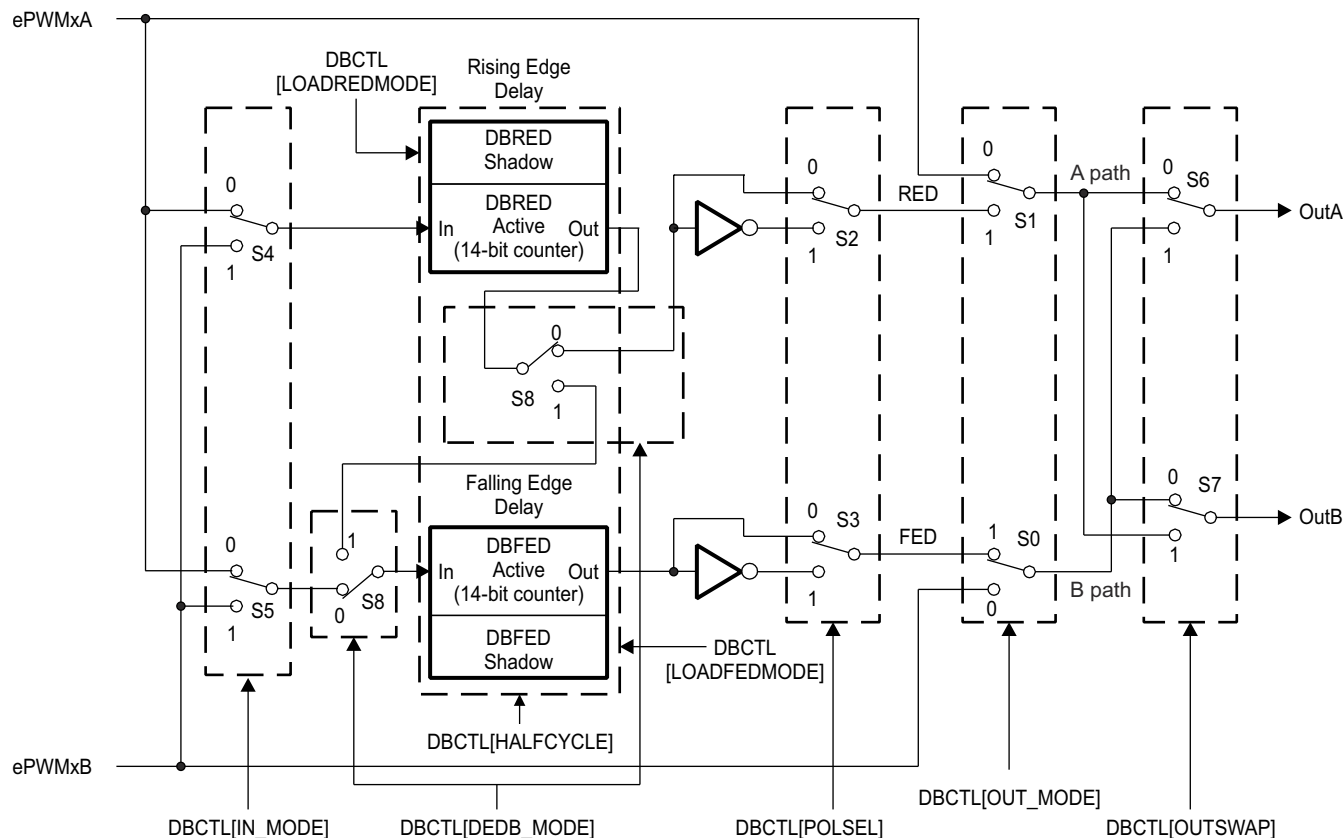

Figure 7-144. Configuration Options for the Dead-Band Submodule

Although all combinations are supported, not all are typical usage modes. [Table 7-115](#) documents some classical dead-band configurations. These modes assume that the DBCTL[IN_MODE] is configured such that EPWMxA In is the source for both falling-edge and rising-edge delay. Enhanced, or non-traditional modes can be achieved by changing the input signal source. The modes shown in [Table 7-115](#) fall into the following categories:

- **Mode 1: Bypass both falling-edge delay (FED) and rising-edge delay (RED)**

Allows you to fully disable the dead-band submodule from the PWM signal path.

- **Mode 2-5: Classical Dead-Band Polarity Settings:**

These represent typical polarity configurations that should address all the active high/low modes required by available industry power switch gate drivers. The waveforms for these typical cases are shown in [Figure 7-145](#). Note that to generate equivalent waveforms to [Figure 7-145](#), configure the action-qualifier submodule to generate the signal as shown for EPWMxA.

- **Mode 6: Bypass rising-edge-delay and Mode 7: Bypass falling-edge-delay**

Finally the last two entries in [Table 7-115](#) show combinations where either the falling-edge-delay (FED) or rising-edge-delay (RED) blocks are bypassed.

[Figure 7-145](#) shows waveforms for typical cases where $0\% < \text{duty} < 100\%$.

Table 7-115. Classical Dead-Band Operating Modes

Mode	Mode Description	DBCTL[POLSEL]		DBCTL[OUT_MODE]	
		S3	S2	S1	S0
1	EPWMxA and EPWMxB Passed Through (No Delay)	X	X	0	0
2	Active High Complementary (AHC)	1	0	1	1
3	Active Low Complementary (ALC)	0	1	1	1
4	Active High (AH)	0	0	1	1
5	Active Low (AL)	1	1	1	1
6	EPWMxA Out = EPWMxA In (No Delay)	0 or 1	0 or 1	0	1
	EPWMxB Out = EPWMxA In with Falling Edge Delay				
7	EPWMxA Out = EPWMxA In with Rising Edge Delay	0 or 1	0 or 1	1	0
	EPWMxB Out = EPWMxB In with No Delay				

Table 7-116. Additional Dead-Band Operating Modes

Mode Description	DBCTL[DEDB-MODE]	DBCTL[OUTSWAP]	
	S8	S6	S7
EPWMxA and EPWMxB signals are as defined by OUT-MODE bits.	0	0	0
EPWMxA = A-path as defined by OUT-MODE bits.	0	0	1
EPWMxB = A-path as defined by OUT-MODE bits (rising edge delay or delay-bypassed A-signal path)			
EPWMxA = B-path as defined by OUT-MODE bits (falling edge delay or delay-bypassed B-signal path)	0	1	0
EPWMxB = B-path as defined by OUT-MODE bits			
EPWMxA = B-path as defined by OUT-MODE bits (falling edge delay or delay-bypassed B-signal path)	0	1	1
EPWMxB = A-path as defined by OUT-MODE bits (rising edge delay or delay-bypassed A-signal path)			
Rising edge delay applied to EPWMxA / EPWMxB as selected by S4 switch (IN-MODE bits) on A signal path only.	0	X	X
Falling edge delay applied to EPWMxA / EPWMxB as selected by S5 switch (IN-MODE bits) on B signal path only.			
Rising edge delay and falling edge delay applied to source selected by S4 switch (IN-MODE bits) and output to B signal path only. ⁽¹⁾	1	X	X

- (1) When this bit is set to 1, user should always either set OUT_MODE bits such that Apath = InA **or** OUTSWAP bits such that EPWMxA=Bpath. Otherwise, EPWMxA will be invalid.

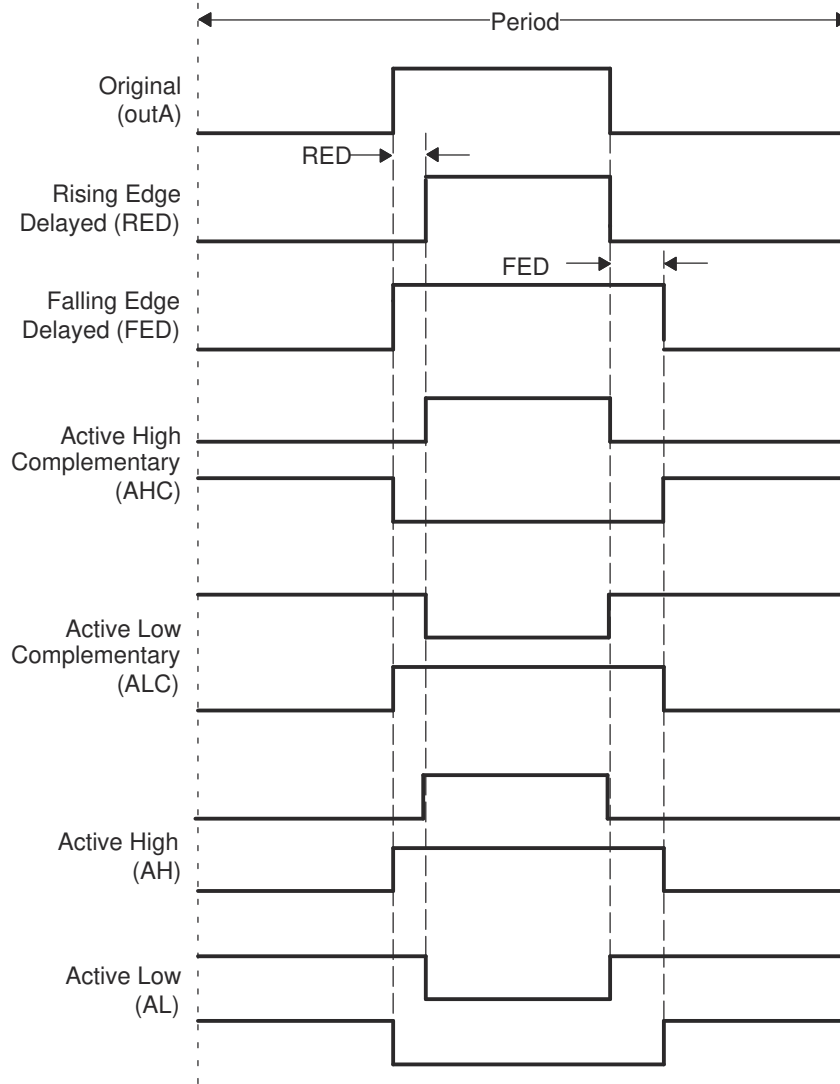

Figure 7-145. Dead-Band Waveforms for Typical Cases (0% < Duty < 100%)

The dead-band submodule supports independent values for rising-edge (RED) and falling-edge (FED) delays. The amount of delay is programmed using the DBRED and DBFED registers. These are 10-bit registers and their value represents the number of time-base clock, TBCLK, periods by which a signal edge is delayed. For example, the formula to calculate falling-edge-delay and rising-edge-delay is:

$$\text{FED} = \text{DBFED} \times T_{\text{TBCLK}}$$

$$\text{RED} = \text{DBRED} \times T_{\text{TBCLK}}$$

Where T_{TBCLK} is the period of TBCLK, the prescaled version of EPWMCLK.

For convenience, delay values for various TBCLK options are shown in [Table 7-117](#). The ePWM input clock frequency that these delay values been computed by is 100 MHz.

Table 7-117. Dead-Band Delay Values in μS as a Function of DBFED and DBRED

Dead-Band Value	Dead-Band Delay in μS			
	DBFED, DBRED	TBCLK = EPWMCLK/1	TBCLK = EPWMCLK /2	TBCLK = EPWMCLK/4
1		0.01 μS	0.02 μS	0.04 μS
5		0.05 μS	0.10 μS	0.20 μS
10		0.10 μS	0.20 μS	0.40 μS
100		1.00 μS	2.00 μS	4.00 μS
200		2.00 μS	4.00 μS	8.00 μS
400		4.00 μS	8.00 μS	16.00 μS
500		5.00 μS	10.00 μS	20.00 μS
600		6.00 μS	12.00 μS	24.00 μS
700		7.00 μS	14.00 μS	28.00 μS
800		8.00 μS	16.00 μS	32.00 μS
900		9.00 μS	18.00 μS	36.00 μS
1000		10.00 μS	20.00 μS	40.00 μS

When half-cycle clocking is enabled, the formula to calculate the falling-edge-delay and rising-edge-delay becomes:

$$\text{FED} = \text{DBFED} \times T_{\text{TBCLK}}/2$$

$$\text{RED} = \text{DBRED} \times T_{\text{TBCLK}}/2$$

7.4.5.9 PWM Chopper (PC) Submodule

The PWM chopper submodule allows a high-frequency carrier signal to modulate the PWM waveform generated by the action-qualifier and dead-band submodules. This capability is important if you need pulse transformer-based gate drivers to control the power switching elements.

7.4.5.9.1 Purpose of the PWM Chopper Submodule

The key functions of the PWM chopper submodule are:

- Programmable chopping (carrier) frequency
- Programmable pulse width of first pulse
- Programmable duty cycle of second and subsequent pulses
- Can be fully bypassed if not required

7.4.5.9.2 Operational Highlights for the PWM Chopper Submodule

Figure 7-146 shows the operational details of the PWM chopper submodule. The carrier clock is derived from EPWMCLK. Its frequency and duty cycle are controlled via the CHPFREQ and CHPDUTY bits in the PCCTL register. The one-shot block is a feature that provides a high energy first pulse to ensure hard and fast power switch turn on, while the subsequent pulses sustain pulses, ensuring the power switch remains on. The one-shot width is programmed via the OSHTWTH bits. The PWM chopper submodule can be fully disabled (bypassed) via the CHPEN bit.

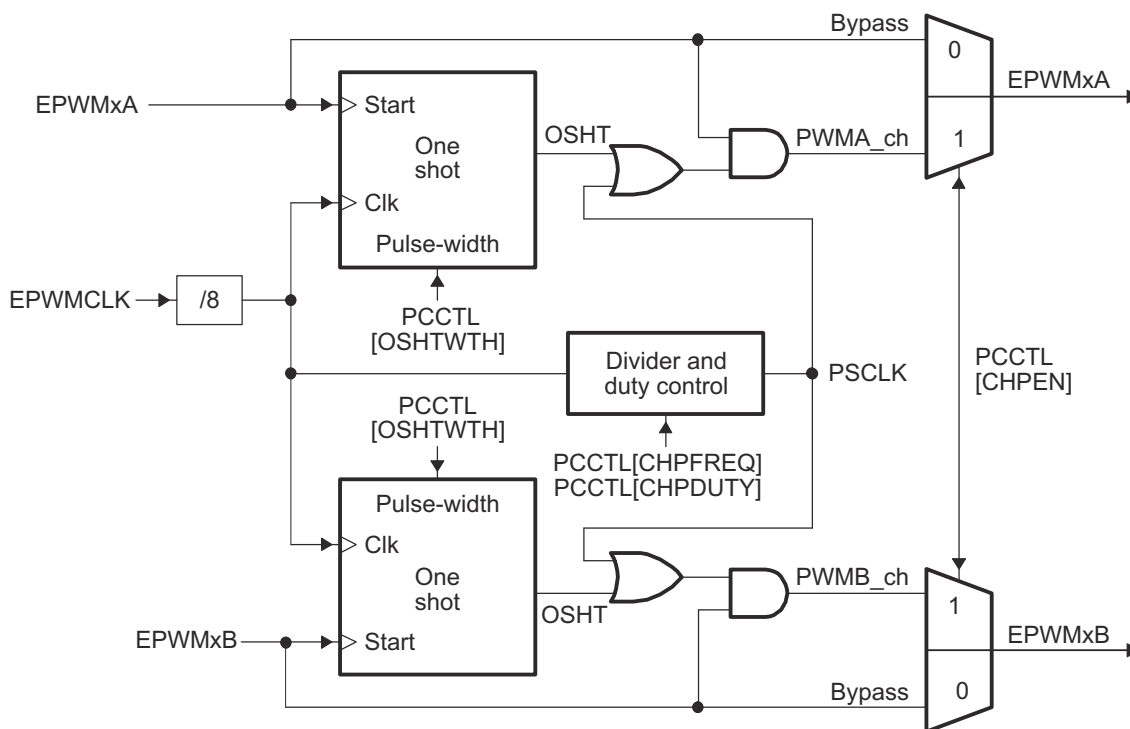

Figure 7-146. PWM Chopper Submodule Operational Details

7.4.5.9.3 Waveforms

Figure 7-147 shows simplified waveforms of the chopping action only; one-shot and duty-cycle control are not shown. Details of the one-shot and duty-cycle control are discussed in the following sections.

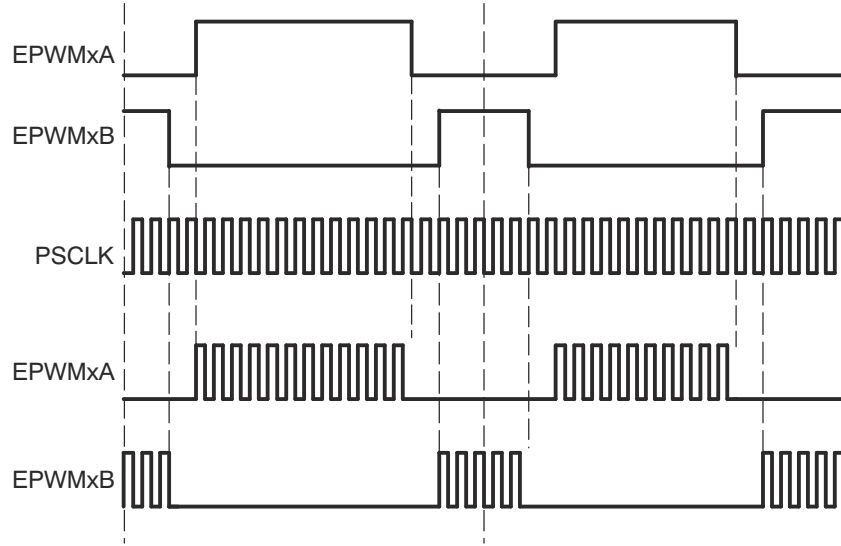

Figure 7-147. Simple PWM Chopper Submodule Waveforms Showing Chopping Action Only

7.4.5.9.3.1 One-Shot Pulse

The width of the first pulse can be programmed to any of 16 possible pulse width values. The width or period of the first pulse is given by:

$$T_{1\text{stpulse}} = T_{\text{EPWMCLK}} \times 8 \times \text{OSHTWTH}$$

Where T_{EPWMCLK} is the period of the system clock (EPWMCLK) and OSHTWTH is the four control bits (value from 1 to 16)

Figure 7-148 shows the first and subsequent sustaining pulses and Table 7-118 gives the possible pulse width values for a EPWMCLK = 80 MHz.

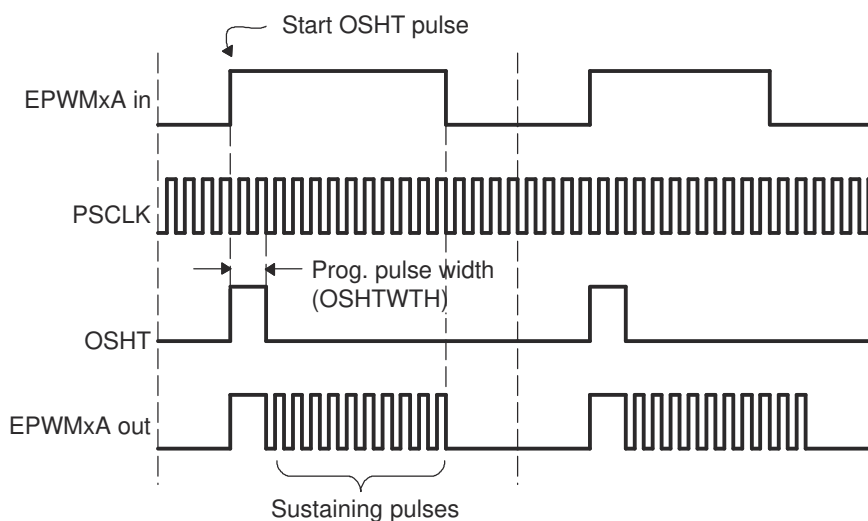

Figure 7-148. PWM Chopper Submodule Waveforms Showing the First Pulse and Subsequent Sustaining Pulses

Table 7-118. Possible Pulse Width Values for EPWMCLK = 80 MHz

OSHTWTHz (hex)	Pulse Width (nS)
0	100
1	200
2	300
3	400
4	500
5	600
6	700
7	800
8	900
9	1000
A	1100
B	1200
C	1300
D	1400
E	1500
F	1600

7.4.5.9.3.2 Duty Cycle Control

Pulse transformer-based gate drive designs need to comprehend the magnetic properties or characteristics of the transformer and associated circuitry. Saturation is one such consideration. To assist the gate drive designer, the duty cycles of the second and subsequent pulses have been made programmable. These sustaining pulses ensure the correct drive strength and polarity is maintained on the power switch gate during the on period, and hence a programmable duty cycle allows a design to be tuned or optimized via software control.

Figure 7-149 shows the duty cycle control that is possible by programming the CHPDUTY bits. One of seven possible duty ratios can be selected ranging from 12.5% to 87.5%.

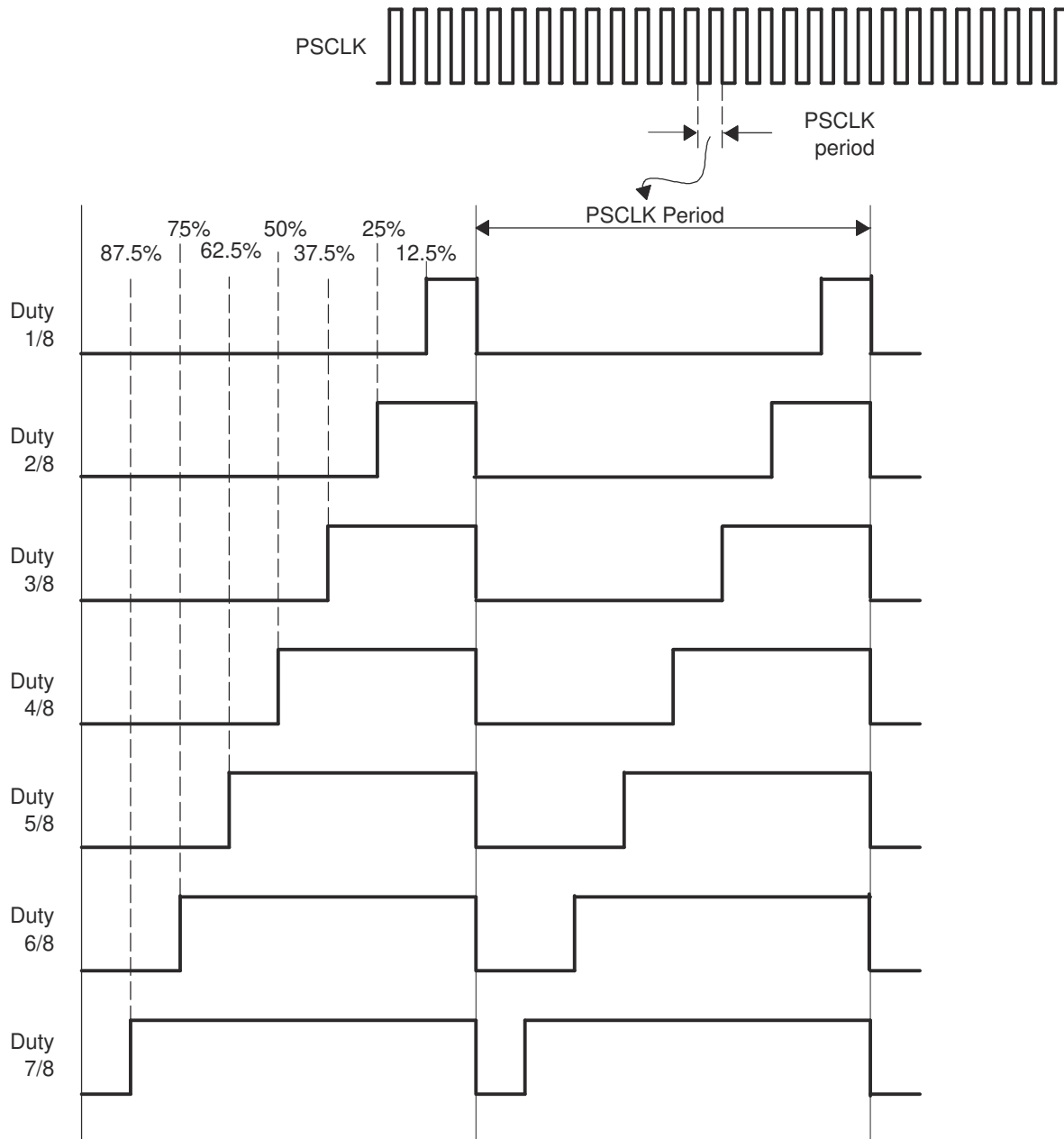

Figure 7-149. PWM Chopper Submodule Waveforms Showing the Pulse Width (Duty Cycle) Control of Sustaining Pulses

ADVANCE INFORMATION

7.4.5.10 Trip-Zone (TZ) Submodule

Each ePWM module is connected to six \overline{TZn} signals ($\overline{TZ1}$ to $\overline{TZ6}$). $\overline{TZ1}$ to $\overline{TZ3}$ are sourced from the GPIO mux. $\overline{TZ4}$ is sourced from an inverted EQEPxERR signal on those devices with an EQEP module. $\overline{TZ5}$ is connected to the system clock fail logic, and $\overline{TZ6}$ is sourced from the EMUSTOP output from the CPU. These signals indicate external fault or trip conditions, and the ePWM outputs can be programmed to respond accordingly when faults occur.

7.4.5.10.1 Purpose of the Trip-Zone Submodule

The key functions of the trip-zone submodule are:

- Trip inputs $\overline{TZ1}$ to $\overline{TZ6}$ can be flexibly mapped to any ePWM module.
- Upon a fault condition, outputs EPWMxA and EPWMxB can be forced to one of the following:
 - High
 - Low
 - High-impedance
 - No action taken
- Support for one-shot trip (OSHT) for major short circuits or over-current conditions.
- Support for cycle-by-cycle tripping (CBC) for current limiting operation.
- Support for digital compare tripping (DC) based on state of on-chip analog comparator module outputs and/or $\overline{TZ1}$ to $\overline{TZ3}$ signals.
- Each trip-zone input and digital compare (DC) submodule DCAEVT1/2 or DCBEVT1/2 force event can be allocated to either one-shot or cycle-by-cycle operation.
- Interrupt generation is possible on any trip-zone input.
- Software-forced tripping is also supported.
- The trip-zone submodule can be fully bypassed if it is not required.

7.4.5.10.2 Operational Highlights for the Trip-Zone Submodule

The following sections describe the operational highlights and configuration options for the trip-zone submodule.

The trip-zone signals $\overline{TZ1}$ to $\overline{TZ6}$ (also collectively referred to as \overline{TZn}) are active-low input signals. When one of these signals goes low, or when a DCAEVT1/2 or DCBEVT1/2 force happens based on the TZDCSEL register event selection, it indicates that a trip event has occurred. Each ePWM module can be individually configured to ignore or use each of the trip-zone signals or DC events. Which trip-zone signals or DC events are used by a particular ePWM module is determined by the TZSEL register for that specific ePWM module. The trip-zone signals may or may not be synchronized to the ePWMclock (EPWMCLK) and digitally filtered within the GPIO MUX block. A minimum of $3 \cdot TBCLK$ low pulse width on \overline{TZn} inputs is sufficient to trigger a fault condition on the ePWM module. If the pulse width is less than this, the trip condition may not be latched by CBC or OST latches. The asynchronous trip makes sure that if clocks are missing for any reason, the outputs can still be tripped by a valid event present on \overline{TZn} inputs. The GPIOs or peripherals must be appropriately configured. For more information, see the *System Control and Interrupts* chapter.

Each \overline{TZn} input can be individually configured to provide either a cycle-by-cycle or one-shot trip event for an ePWM module. DCAEVT1 and DCBEVT1 events can be configured to directly trip an ePWM module or provide a one-shot trip event to the module. Likewise, DCAEVT2 and DCBEVT2 events can also be configured to directly trip an ePWM module or provide a cycle-by-cycle trip event to the module. This configuration is determined by the TZSEL[DCAEVT1/2], TZSEL[DCBEVT1/2], TZSEL[CBCn], and TZSEL[OSHTn] control bits (where n corresponds to the trip input), respectively.

- **Cycle-by-Cycle (CBC):**

When a cycle-by-cycle trip event occurs, the action specified in the TZCTL[TZA] and TZCTL[TZB] bits is carried out immediately on the EPWMxA and/or EPWMxB outputs. [Table 7-119](#) lists some of the possible actions. Independent actions can be specified based on the occurrence of the event while the counter is counting up and/or while it is counting down by appropriately configuring bits in the TZCTL2 register. Actions specified in the TZCTL2 register take effect only when the ETZE bit in TZCTL2 is set.

Additionally, when a cycle-by-cycle trip event occurs, the cycle-by-cycle trip event flag (TZFLG[CBC]) is set and a EPWMx_TZINT interrupt is generated if it is enabled in the TZEINT register and PIE peripheral. A corresponding flag for the event that caused the CBC event is also set in register TZCBCFLG.

If the CBC interrupt is enabled via the TZEINT register, and DCAEVT2 or DCBEVT2 are selected as CBC trip sources via the TZSEL register, it is not necessary to also enable the DCAEVT2 or DCBEVT2 interrupts in the TZEINT register, as the DC events trigger interrupts through the CBC mechanism.

The specified condition on the inputs is automatically cleared based on the selection made with TZCLR[CBCPULSE] if the trip event is no longer present. Therefore, in this mode, the trip event is cleared or reset every PWM cycle. The TZFLG[CBC] and TZCBCFLG flag bits will remain set until they are manually cleared by writing to the TZCLR[CBC] and TZCBCCLR flag bits. If the cycle-by-cycle trip event is still present when the TZFLG[CBC] and/or TZCBCFLG register bits are cleared, then these bits will again be immediately set.

- **One-Shot (OSHT):**

When a one-shot trip event occurs, the action specified in the TZCTL[TZA] and TZCTL[TZB] bits is carried out immediately on the EPWMxA and/or EPWMxB output. [Table 7-119](#) lists some of the possible actions. Independent actions can be specified based on the occurrence of the event while the counter is counting up and/or while it is counting down by appropriately configuring bits in TZCTL2 register. Actions specified in TZCTL2 register take effect only when ETZE bit in TZCTL2 is set.

Additionally, when a one-shot trip event occurs, the one-shot trip event flag (TZFLG[OST]) is set and a EPWMx_TZINT interrupt is generated if it is enabled in the TZEINT register and PIE peripheral. A corresponding flag for the event that caused the OST event is also set in register TZOSTFLG. The one-shot trip condition must be cleared manually by writing to the TZCLR[OST] bit. If desired, TZOSTFLG register bit should be cleared by manually writing to the corresponding bit in the TZOSTCLR register.

If the one-shot interrupt is enabled via the TZEINT register, and DCAEVT1 or DCBEVT1 are selected as OSHT trip sources via the TZSEL register, it is not necessary to also enable the DCAEVT1 or DCBEVT1 interrupts in the TZEINT register, as the DC events trigger interrupts through the OSHT mechanism.

Note

Clear the TZFLG and TZOSTFLG flags after ensuring that the TRIPIN source of the OST has become inactive. Otherwise, if interrupts are enabled, depending on when the flags are cleared, an OST interrupt could occur and the OST flags are zero.

- **Digital Compare Events (DCAEVT1/2 and DCBEVT1/2):**

A digital compare DCAEVT1/2 or DCBEVT1/2 event is generated based on a combination of the DCAH/DCAL and DCBH/DCBL signals as selected by the TZDCSEL register. The signals which source the DCAH/DCAL and DCBH/DCBL signals are selected via the DCTRISEL register and can be either trip zone input pins or analog comparator CMPSSx signals. For more information on the digital compare submodule signals, see [Section 7.4.5.12](#).

When a digital compare event occurs, the action specified in the TZCTL[DCAEVT1/2] and TZCTL[DCBEVT1/2] bits is carried out immediately on the EPWMxA and/or EPWMxB output. [Table 7-119](#) lists the possible actions. Independent actions can be specified based on the occurrence of the event while the counter is counting up and/or while it is counting down by appropriately configuring bits in TZCTLDCA and TZCTLDCB register. Actions specified in TZCTLDCA and TZCTLDCB registers take effect only when ETZE bit in TZCTL2 is set.

In addition, the relevant DC trip event flag (TZFLG[DCAEVT1/2] / TZFLG[DCBEVT1/2]) is set and a EPWMx_TZINT interrupt is generated if it is enabled in the TZEINT register and PIE peripheral.

The specified condition on the pins is automatically cleared when the DC trip event is no longer present. The TZFLG[DCAEVT1/2] or TZFLG[DCBEVT1/2] flag bit will remain set until it is manually cleared by writing to the TZCLR[DCAEVT1/2] or TZCLR[DCBEVT1/2] bit. If the DC trip event is still present when the TZFLG[DCAEVT1/2] or TZFLG[DCBEVT1/2] flag is cleared, then it will again be immediately set.

The action taken when a trip event occurs can be configured individually for each of the ePWM output pins by way of the TZCTL, TZCTL2, TZCTLDCA, and TZCTLDCB register bit fields. Some of the possible actions, shown in [Table 7-119](#), can be taken on a trip event.

Table 7-119. Possible Actions On a Trip Event

TZCTL Register Bitfield Settings	EPWMxA and/or EPWMxB	Comment
0,0	High-Impedance	Tripped
0,1	Force to High State	Tripped
1,0	Force to Low State	Tripped
1,1	No Change	Do Nothing. No change is made to the output.

Example 7-1. Trip-Zone Configurations

Scenario A:

A one-shot trip event on $\overline{TZ1}$ pulls both EPWM1A, EPWM1B low and also forces EPWM2A and EPWM2B high.

- Configure the ePWM1 registers as follows:
 - TZSEL[OSHT1] = 1: enables $\overline{TZ1}$ as a one-shot event source for ePWM1
 - TZCTL[TZA] = 2: EPWM1A will be forced low on a trip event.
 - TZCTL[TZB] = 2: EPWM1B will be forced low on a trip event.
- Configure the ePWM2 registers as follows:
 - TZSEL[OSHT1] = 1: enables $\overline{TZ1}$ as a one-shot event source for ePWM2
 - TZCTL[TZA] = 1: EPWM2A will be forced high on a trip event.
 - TZCTL[TZB] = 1: EPWM2B will be forced high on a trip event.

Scenario B:

A cycle-by-cycle event on $\overline{TZ5}$ pulls both EPWM1A, EPWM1B low.

A one-shot event on $\overline{TZ1}$ or $\overline{TZ6}$ puts EPWM2A into a high impedance state.

- Configure the ePWM1 registers as follows:
 - TZSEL[CBC5] = 1: enables $\overline{TZ5}$ as a one-shot event source for ePWM1
 - TZCTL[TZA] = 2: EPWM1A will be forced low on a trip event.
 - TZCTL[TZB] = 2: EPWM1B will be forced low on a trip event.
- Configure the ePWM2 registers as follows:
 - TZSEL[OSHT1] = 1: enables $\overline{TZ1}$ as a one-shot event source for ePWM2
 - TZSEL[OSHT6] = 1: enables $\overline{TZ6}$ as a one-shot event source for ePWM2
 - TZCTL[TZA] = 0: EPWM2A will be put into a high-impedance state on a trip event.
 - TZCTL[TZB] = 3: EPWM2B will ignore the trip event.

Note

When configuring the GPIOs and INPUT X-BAR/EPWM X-BAR options, be aware that a change in the X-BAR input selections may cause an unwanted event. Therefore, ideally, the user will set up the GPIO and X-BAR input configurations before enabling the ePWM Trip-Zone. If it is a requirement to change the GPIO/X-BAR configurations while the ePWM Trip-Zone is enabled, the user can turn off the TRIPs by clearing the TZSEL register and re-configuring the TRIP selection (TZSEL) after the INPUT XBAR selection is changed.

7.4.5.10.3 Generating Trip Event Interrupts

Figure 7-150 and Figure 7-151 illustrate the trip-zone submodule control and interrupt logic, respectively. DCAEVT1/2 and DCBEVT1/2 signals are described in further detail in Section 7.4.5.12.

ADVANCE INFORMATION

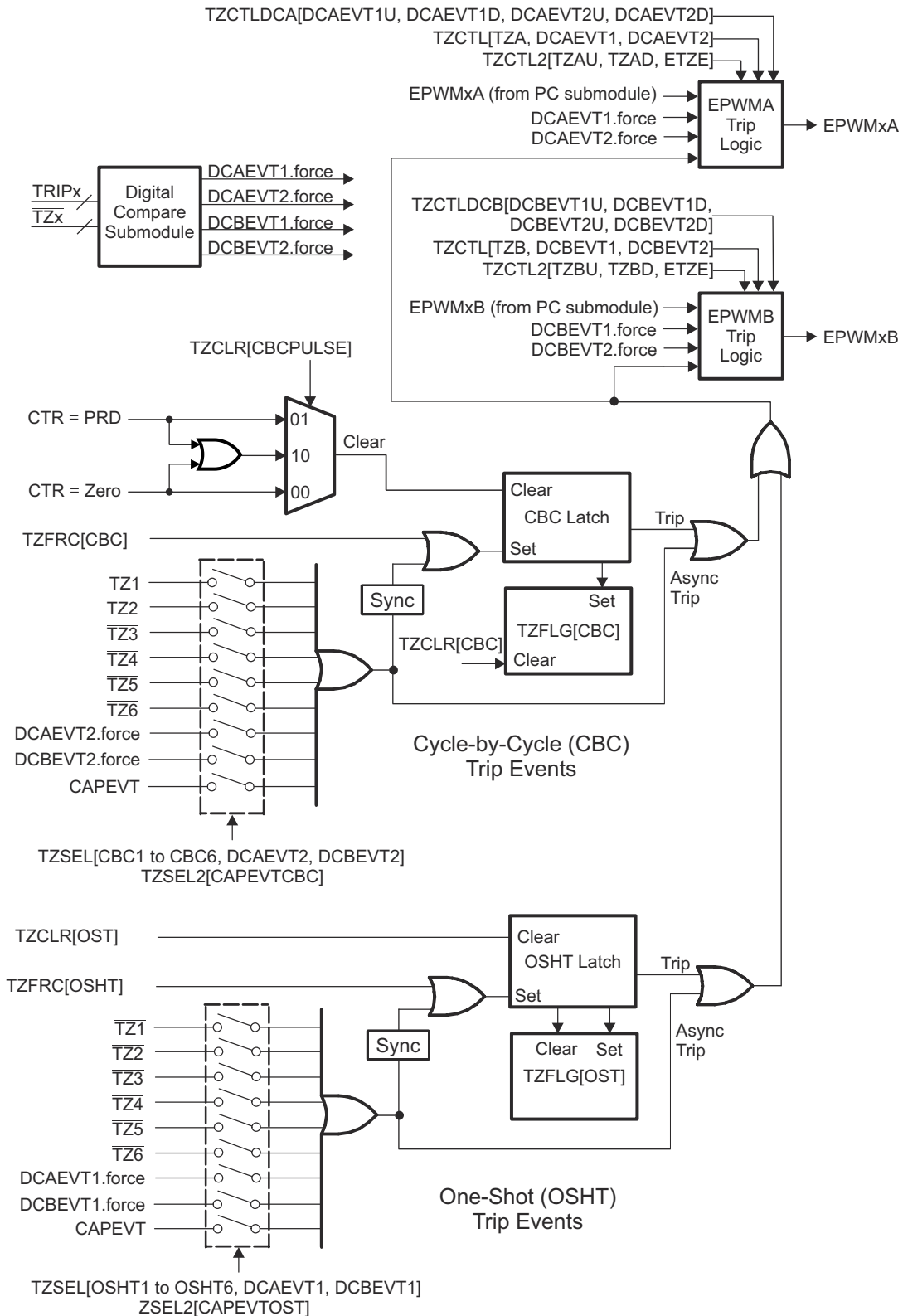
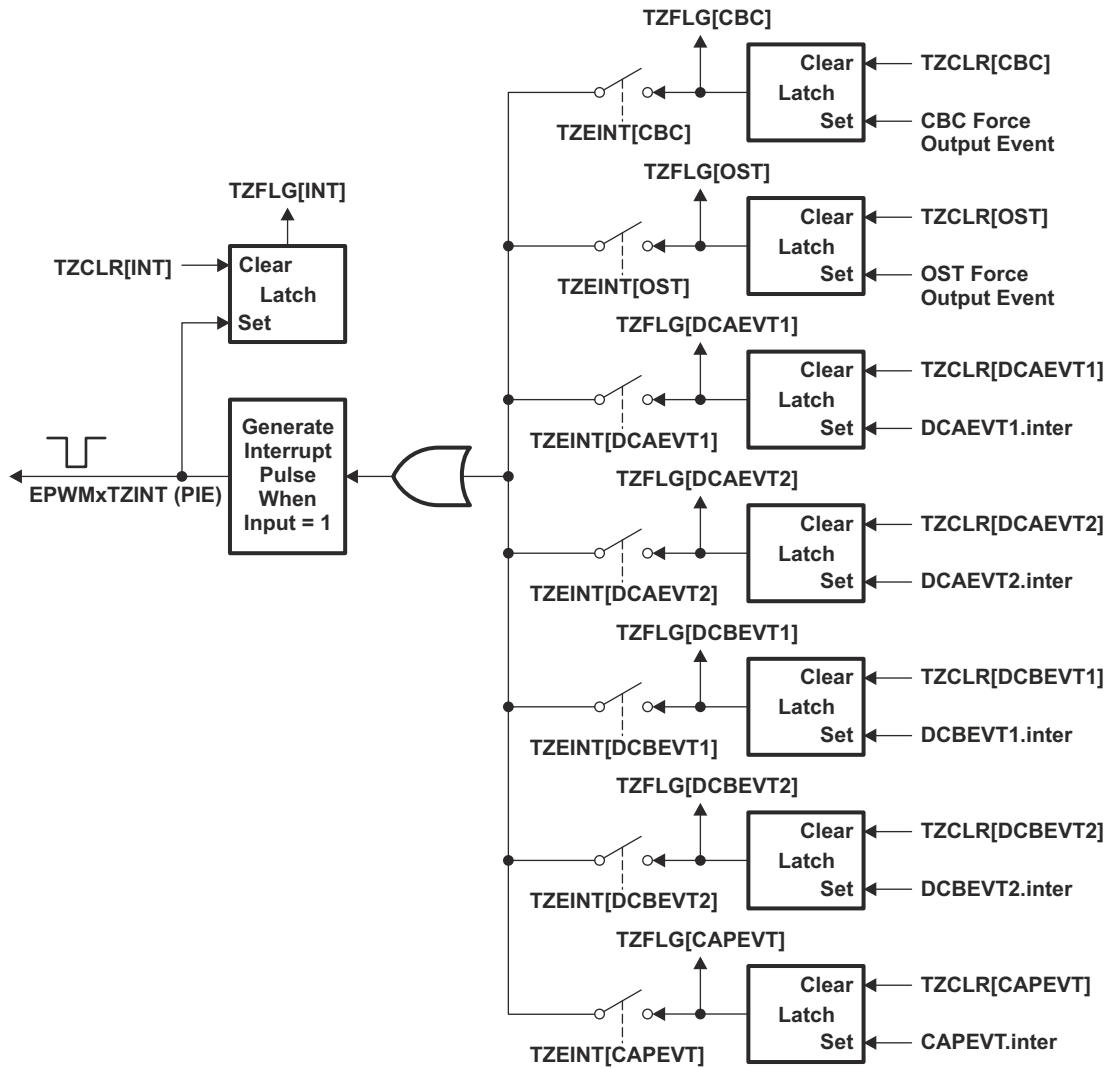

Figure 7-150. Trip-Zone Submodule Mode Control Logic



ADVANCE INFORMATION

Figure 7-151. Trip-Zone Submodule Interrupt Logic

The signal CAPEVT is generated from the Capture Control Logic and is available in type 5 EPWM.

These individual flags for the CBC, OST and DCxEVTy can be used to detect the source of the EPWMxTZINT Interrupt. When multiple sources are used to generate the EPWMxTZINT interrupt, reading and clearing the flags will user to take different actions based on the specific event.

7.4.5.11 Event-Trigger (ET) Submodule

The key functions of the event-trigger submodule are:

- Receives event inputs generated by the time-base, counter-compare, and digital-compare submodules
- Uses the time-base direction information for up/down event qualification
- Uses prescaling logic to issue interrupt requests and ADC start of conversion at:
 - Every event
 - Every second event
 - Up to every fifteenth event
- Provides full visibility of event generation via event counters and flags
- Allows software forcing of Interrupts and ADC start of conversion

The event-trigger submodule manages the events generated by the time-base submodule, the counter-compare submodule, and the digital-compare submodule to generate an interrupt to the CPU and/or a start of conversion pulse to the ADC when a selected event occurs.

7.4.5.11.1 Operational Overview of the ePWM Event-Trigger Submodule

The event-trigger submodule monitors various event conditions (shown as inputs on the left side of Figure 7-152) and can be configured to prescale these events before issuing an Interrupt request or an ADC start of conversion. The event-trigger prescaling logic can issue Interrupt requests and ADC start of conversion at:

- Every event
- Every second event
- Up to every fifteenth event

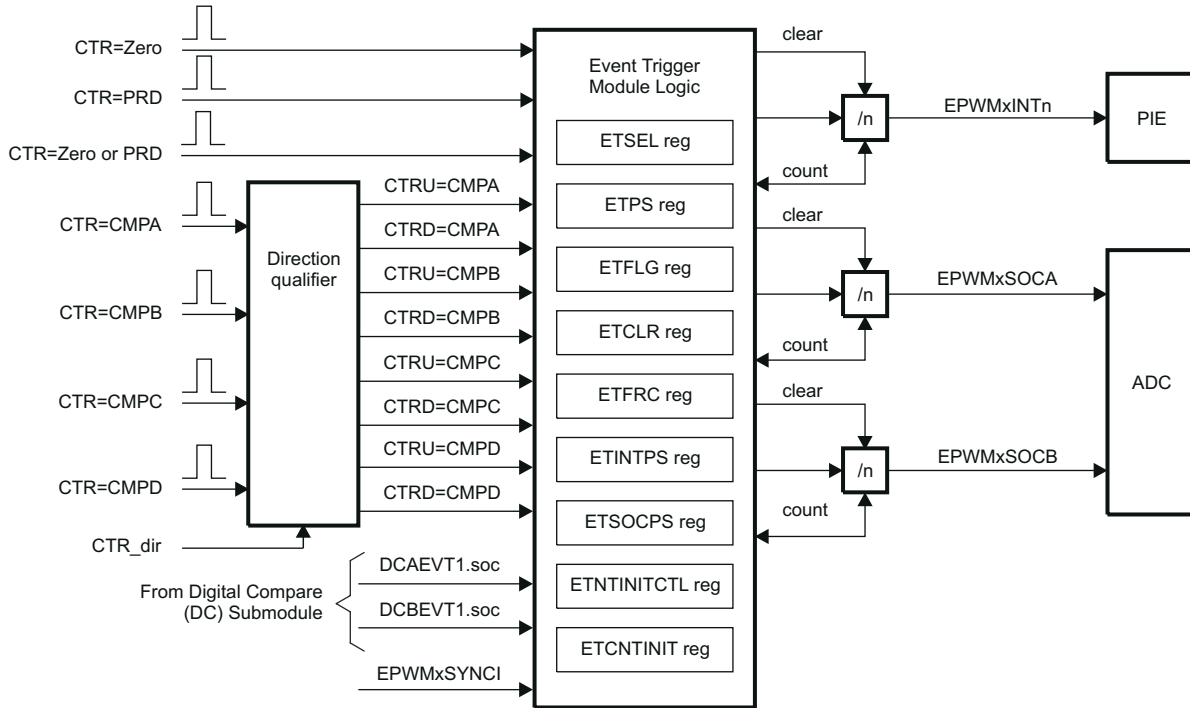

Figure 7-152. Event-Trigger Submodule Showing Event Inputs and Prescaled Outputs

- ETSEL - This selects which of the possible events will trigger an interrupt or start an ADC conversion.
- ETPS - This programs the event prescaling options mentioned above.
- ETFLG - These are flag bits indicating status of the selected and prescaled events.
- ETCLR - These bits allow you to clear the flag bits in the ETFLG register via software.
- ETFRC - These bits allow software forcing of an event. Useful for debugging or software intervention.
- ETINTPS - This programs the interrupt event prescaling options, supporting count and period up to 15 events.
- ETSOCPs - This programs the SOC event prescaling options, supporting count and period up to 15 events.
- ETCNTINITCTL - These bits enable ETCNTINIT initialization via SYNC event OR via software force.
- ETCNTINIT - These bits allow you to initialize INT/SOCA/SOCB counters on SYNC events (or software force) with user programmed value.

A more detailed look at how the various register bits interact with the Interrupt and ADC start of conversion logic are shown in Figure 7-153, Figure 7-154, and Figure 7-155.

Figure 7-153 shows the event-trigger's interrupt generation logic. The interrupt-period (ETPS[INTPRD]) bits specify the number of events required to cause an interrupt pulse to be generated. The choices available are:

- Do not generate an interrupt.
- Generate an interrupt on every event.
- Generate an interrupt on every second event.
- Generate an interrupt on every third event.

On ePWM type 4, in order to enable event generation capability up to 15 events the following changes have been made. The selection made on ETPS[INTPSSEL] bit determines whether ETINTPS register, INTCNT2 and INTPRD2 bit fields determine frequency of events (interrupt once every 0-15 events).

The event that can cause an interrupt is configured by the interrupt selection (ETSEL[INTSEL]) and (ETSEL[INTSELCMP]) bits. The event can be one of the following:

- Time-base counter equal to zero (TBCTR = 0x00).
- Time-base counter equal to period (TBCTR = TBPRD).
- Time-base counter equal to zero or period (TBCTR = 0x00 || TBCTR = TBPRD).
- Time-base counter equal to the compare A register (CMPA) when the timer is incrementing.
- Time-base counter equal to the compare A register (CMPA) when the timer is decrementing.
- Time-base counter equal to the compare B register (CMPB) when the timer is incrementing.
- Time-base counter equal to the compare B register (CMPB) when the timer is decrementing.
- Time-base counter equal to the compare C register (CMPC) when the timer is incrementing.
- Time-base counter equal to the compare C register (CMPC) when the timer is decrementing.
- Time-base counter equal to the compare D register (CMPD) when the timer is incrementing.
- Time-base counter equal to the compare D register (CMPD) when the timer is decrementing.

The number of events that have occurred can be read from the interrupt event counter ETPS[INTCNT] or ETINTPS[INTCNT2] register bits based off of the selection made using ETPS[INTPSSEL]. That is, when the specified event occurs the ETPS[INTCNT] or ETINTPS[INTCNT2] bits are incremented until they reach the value specified by ETPS[INTPRD] or ETINTPS[INTPRD2] determined again by the selection made in ETPS[INTPSSEL]. When ETPS[INTCNT] = ETPS[INTPRD] the counter stops counting and its output is set. The counter is only cleared when an interrupt is sent to the PIE.

When ETPS[INTCNT] reaches ETPS[INTPRD] the following behavior will occur [The below behavior is also applicable to ETINTPS[INTCNT2] and ETINTPS[INTPRD2]:

- If interrupts are enabled, ETSEL[INTEN] = 1 and the interrupt flag is clear, ETFLG[INT] = 0, then an interrupt pulse is generated and the interrupt flag is set, ETFLG[INT] = 1, and the event counter is cleared ETPS[INTCNT] = 0. The counter will begin counting events again.
- If interrupts are disabled, ETSEL[INTEN] = 0, or the interrupt flag is set, ETFLG[INT] = 1, the counter stops counting events when it reaches the period value ETPS[INTCNT] = ETPS[INTPRD].
- If interrupts are enabled, but the interrupt flag is already set, then the counter will hold its output high until the ENTFLG[INT] flag is cleared. This allows for one interrupt to be pending while one is serviced.

Writing '0' to the INTPRD bits will automatically clear the counter INTCNT = 0 and the counter output will be reset (so no interrupts are generated). Writing a 1 to the ETFRC[INT] bit will increment the event counter INTCNT. The counter will behave as described above when INTCNT = INTPRD. When INTPRD = 0, the counter is disabled and hence no events will be detected and the ETFRC[INT] bit is also ignored. The same applies to ETINTPS[INTCNT2] and ETINTPS[INTPRD2]

The above definition means that you can generate an interrupt on every event, on every second event, or on every third event if using the INTCNT and INTPRD. You can generate an interrupt on every event up to 15 events if using the INTCNT2 and INTPRD2.

The INTCNT2 value can be initialized with the value from ETCNTINIT[INTINIT] based on the selection made in ETCNTINITCTL[INTINITEN]. When ETCNTINITCTL[INTINITEN] is set, then it enables initialization of INTCNT2 counter with contents of ETCNTINIT[INTINIT] on a SYNC event or software force determined by ETCNTINITCTL[INTINITFRC].

ETINTMIX, ETSOCAMIX and ETSOCBMIX Signals (Type 5 ePWM)

In type 5 ePWM, the Event-Trigger submodule can generate and use ETINTMIX, ETSOCAMIX and ETSOCBMIX signals.

- **ETINTMIX:** This signal is a generated from the ORed combination of the sources enabled in the ETINTMIXEN register. The ETINTMIX signal can be used as a source for the EPWMxINT interrupt.

- **ETSOCAMIX:** This signal is generated from the ORed combination of the sources enabled in the ETSOCAMIXEN register. The ETSOCAMIX signal can be used as a source for the EPWMxSOCA trigger signal.
- **ETSOCBMIX:** This signal is generated from the ORed combination of the sources enabled in the ETSOCBMIXEN register. The ETSOCBMIX signal can be used as a source for the EPWMxSOCB trigger signal.

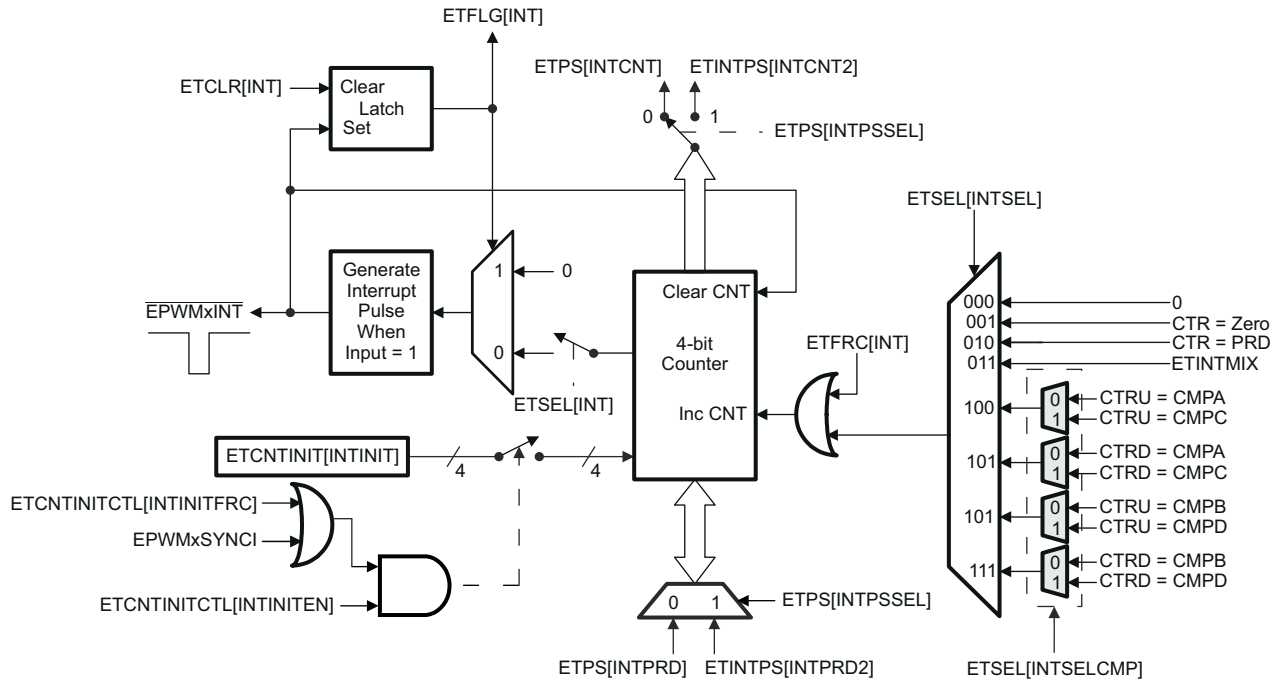
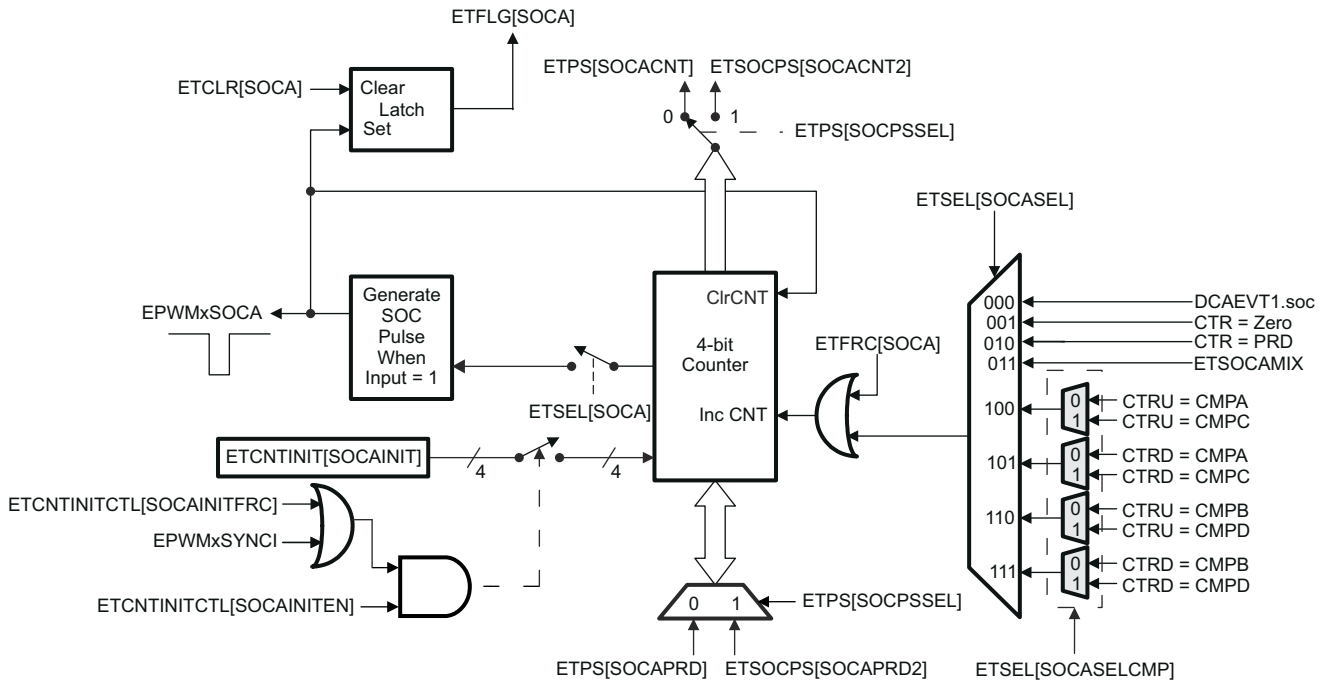

Figure 7-153. Event-Trigger Interrupt Generator

Figure 7-154 shows the operation of the event-trigger's start-of-conversion-A (SOCA) pulse generator. The enhancements include SOCASELCMP and SOCBSELCMP bit fields defined in the ETSEL register enable CMPC and CMPD events respectively to cause a start of conversion. The ETPS[SOCPSSEL] bit field determines whether SOCACNT2 and SOCAPRD2 take control or not. The ETPS[SOCACNT] counter and ETPS[SOCAPRD] period values behave similarly to the interrupt generator except that the pulses are continuously generated. That is, the pulse flag ETFLG[SOCA] is latched when a pulse is generated, but it does not stop further pulse generation. The enable/disable bit ETSEL[SOCASEN] stops pulse generation, but input events can still be counted until the period value is reached as with the interrupt generation logic. The event that will trigger an SOCA and SOCB pulse can be configured separately in the ETSEL[SOCASEL] and ETSEL[SOCBSEL] bits. The possible events are the same events that can be specified for the interrupt generation logic with the addition of the DCAEVT1.soc and DCBEVT1.soc event signals from the digital compare (DC) submodule. The SOCACNT2 initialization scheme is very similar to the interrupt generator with respective enable, value initialize and SYNC or software force options.



NOTE: The DCAEVT1.soc signals are generated by the Digital Compare (DC) submodule in Section 7.4.5.12.

Figure 7-154. Event-Trigger SOCA Pulse Generator

Figure 7-155 shows the operation of the event-trigger's start-of-conversion-B (SOCB) pulse generator. The event-trigger's SOCB pulse generator operates the same way as the SOCA.

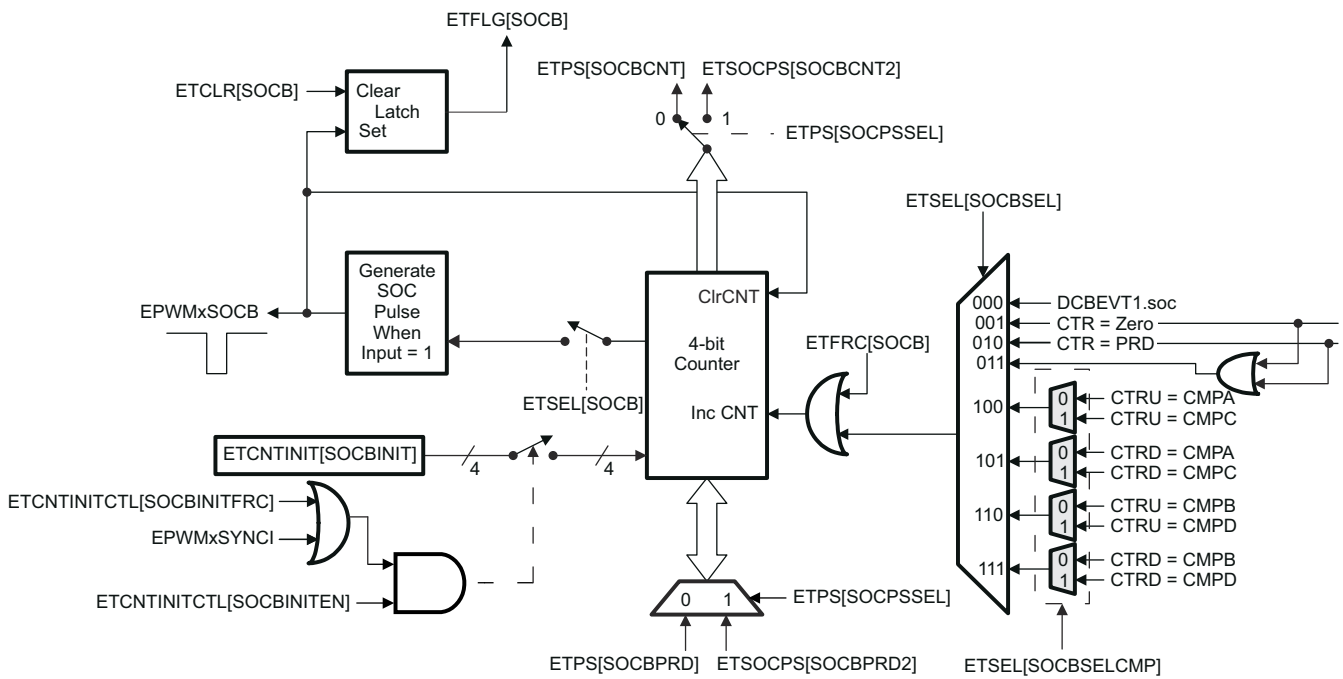

NOTE: The DCBEVT1.soc signals are generated by the Digital Compare (DC) submodule in Section 7.4.5.12.

Figure 7-155. Event-Trigger SOCB Pulse Generator

7.4.5.12 Digital Compare (DC) Submodule

On this device, any of the GPIO pins can be flexibly mapped to be the trip-zone input and/or trip inputs to the trip-zone submodule and digital compare submodule. The Input X-BAR Input Select (INPUTxSELECT) register defines which GPIO pins gets assigned to be the trip-zone inputs / trip inputs.

The digital compare (DC) submodule compares signals external to the ePWM module (for instance, CMPSSx signals from the analog comparators) to directly generate PWM events/actions which then feed to the event-trigger, trip-zone, and time-base submodules. Additionally, blanking window functionality is supported to filter noise or unwanted pulses from the DC event signals.

Note

You are responsible for driving correct state on the selected pin before enabling clock and configuring the trip input for the respective ePWM peripheral to avoid spurious latch of TRIP signal.

7.4.5.12.1 Purpose of the Digital Compare Submodule

The key functions of the digital compare submodule are:

- Analog comparator (COMP) module outputs fed through the Input X-BAR logic externally using the GPIO peripheral, internal PIE, ECC error signals, TZ1, TZ2, and TZ3 inputs generate Digital Compare A High/Low (DCAH, DCAL) and Digital Compare B High/Low (DCBH, DCBL) signals.
- DCAH/L and DCBH/L signals trigger events which can then either be filtered or fed directly to the trip-zone, event-trigger, and time-base submodules to:
 - generate a trip zone interrupt
 - generate an ADC start of conversion
 - force an event
 - generate a synchronization event for synchronizing the ePWM module TBCTR.
- Event filtering (blanking window logic) can optionally blank the input signal to remove noise.

7.4.5.12.2 Enhanced Trip Action Using CMPSS

To allow multiple CMPSS at a time to affect DCA/BEVTx events and trip actions, there is a OR logic to bring together ALL trip inputs (up to 15) from sources external to the ePWM module and feed into DCAH, DCAL, DCBH, and DCBL as a “combinational input” using the DCTRIPSEL register. This is configured by selecting “Trip combination input” (value of 0xF) in the DCTRIPSEL register.

You have a discrete choice of which trip inputs to put through the combinational logic for generating the DCAH, DCAL, DCBH and DCBL signals. This is achieved using the DCAHTRIPSEL, DCALTRIPSEL, DCBHTRIPSEL and DCBLTRIPSEL register selections. Inputs selected for combinational input are passed through to the DCTRIPSEL register.

7.4.5.12.3 Using CMPSS to Trip the ePWM on a Cycle-by-Cycle Basis

When using the CMPSS to trip the ePWM on a cycle-by-cycle basis, steps should be taken to prevent an asserted comparator trip state in one PWM cycle from extending into the following cycle. The CMPSS can be used to signal a trip condition to the downstream ePWM modules. For applications like peak current mode control, only one trip event per PWM cycle is expected. Under certain conditions, it is possible for a sustained or late trip event (arriving near the end of a PWM cycle) to carry over into the next PWM cycle if precautions are not taken. If either the CMPSS Digital Filter or the ePWM Digital Compare (DC) submodule is configured to qualify the comparator trip signal, “N” number of clock cycles of qualification will be introduced before the ePWM trip logic can respond to logic changes of the trip signal. Once an ePWM trip condition is qualified, the trip condition will remain active for N clock cycles after the comparator trip signal has de-asserted. If a qualified comparator trip signal remains asserted within N clock cycles prior to the end of a PWM cycle, the trip condition will not be cleared until after the following PWM cycle has started. Thus, the new PWM cycle will detect a trip condition as soon as it begins.

To avoid this undesired trip condition, your application can take steps to make sure that the qualified trip signal seen by the ePWM trip logic is deasserted prior to the end of each PWM cycle. This can be accomplished through various methods:

- Design the system such that a comparator trip is not asserted within N clock cycles prior to the end of the PWM cycle.
- Activate blanking of the comparator trip signal via the ePWM event filter at least two clock cycles prior to the PWMSYNCPER signal and continue blanking for at least N clock cycles into the next PWM cycle.
- If the CMPSS COMPxLATCH path is used, clear the COMPxLATCH at least N clock cycles prior to the end of the PWM cycle. The latch can be cleared by software (via COMPSTCLR) or by generating an early PWMSYNCPER signal. The ePWM modules on this device include the ability to generate PWMSYNCPER upon a CMPC or CMPD match (via HRPCTL) for arbitrary PWMSYNCPER placement within the PWM cycle.

7.4.5.12.4 Operation Highlights of the Digital Compare Submodule

The following sections describe the operational highlights and configuration options for the digital compare submodule.

7.4.5.12.4.1 Digital Compare Events

As described in [Section 7.4.5.12.1](#), trip zone inputs ($\overline{TZ1}$, $\overline{TZ2}$, and $\overline{TZ3}$) and CMPSSx signals from the analog comparator (COMP) module can be selected using the DCTRISEL bits to generate the Digital Compare A High and Low (DCAH/L) and Digital Compare B High and Low (DCBH/L) signals. Then, the configuration of the TZDCSEL register qualifies the actions on the selected DCAH/L and DCBH/L signals, which generate the DCAEVT1/2 and DCBEVT1/2 events (Event Qualification A and B).

Note

The \overline{TZn} signals, when used as a DCEVT tripping functions, are treated as a normal input signal and can be defined to be active-high or active-low inputs. ePWM outputs are asynchronously tripped when either the \overline{TZn} , DCAEVTx.force, or DCBEVTx.force signals are active. For the condition to remain latched, a minimum of $3 \cdot TBCLK$ sync pulse width is required. If pulse width is $< 3 \cdot TBCLK$ sync pulse width, the trip condition can or can not get latched by CBC or OST latches.

The DCAEVT1/2 and DCBEVT1/2 events can then be filtered to provide a filtered version of the event signals (DCEVTFILT) or the filtering can be bypassed. Filtering is discussed further in [. Either the DCAEVT1/2 and DCBEVT1/2 event signals or the filtered DCEVTFILT event signals can generate a force to the trip zone module, a TZ interrupt, an ADC SOC, or a PWM sync signal.](#)

- **force signal:** DCAEVT1/2.force signals force trip zone conditions which either directly influence the output on the EPWMxA pin (via TZCTL, TZCTLDCA, TZCTLDCB register configurations) or, if the DCAEVT1/2 signals are selected as one-shot or cycle-by-cycle trip sources (via the TZSEL register), the DCAEVT1/2.force signals can effect the trip action via the TZCTL or TZCTL2 register configurations. The DCBEVT1/2.force signals behaves similarly, but affect the EPWMxB output pin instead of the EPWMxA output pin.

The priority of conflicting actions on the TZCTL, TZCTL2, TZCTLDCA and TZCTLDCB registers is as follows (highest priority overrides lower priority):

Output EPWMxA:

- TZA (highest) -> DCAEVT1 -> DCAEVT2 (lowest)
- TZAU (highest) -> DCAEVT1U -> DCAEVT2U (lowest)
- TZAD (highest) -> DCAEVT1D -> DCAEVT2D (lowest)

Output EPWMxB:

- TZB (highest) -> DCBEVT1 -> DCBEVT2 (lowest)
- TZBU (highest) -> DCBEVT1U -> DCBEVT2U (lowest)
- TZBD (highest) -> DCBEVT1D -> DCBEVT2D (lowest)

- **interrupt signal:** DCAEVT1/2.interrupt signals generate trip zone interrupts to the PIE. To enable the interrupt, you must set the DCAEVT1, DCAEVT2, DCBEVT1, or DCBEVT2 bits in the TZEINT register. Once one of these events occurs, an EPWMxTZINT interrupt is triggered, and the corresponding bit in the TZCLR register must be set to clear the interrupt.
- **soc signal:** The DCAEVT1.soc signal interfaces with the event-trigger submodule and can be selected as an event which generates an ADC start-of-conversion-A (SOCA) pulse via the ETSEL[SOCASEL] bit. Likewise, the DCBEVT1.soc signal can be selected as an event which generates an ADC start-of-conversion-B (SOCB) pulse via the ETSEL[SOCBSEL] bit.
- **sync signal:** The DCAEVT1.sync and DCBEVT1.sync events are ORed with the EPWMxSYNCl input signal and the TBCTL[SWFSYNC] signal to generate a synchronization pulse to the time-base counter.

7.4.5.12.4.2 Valley Switching

Event filtering depicts the valley switching function along with the event filtering logic described in . This function can be used to achieve programmable valley switching without any additional external circuitry. This module provides an on-chip hardware mechanism that can:

- Capture the oscillation period
- Accurately delay the PWM switching instant
- Allow a programmable number of edges before the delay takes effect
- Provide multiple choices of triggers and events
- Allow easy adaptability for optimum performance under changing system/operating conditions

The DCxEVTy signal needs further processing to support valley switching. Here is a brief description of how valley switching function is enabled:

1. Select one of the DCxEVTy events as input to the valley switching block (DCFCTL[SRSEL]) with an option to add the blanking window (Blank Control Logic). This is where the comparator output (or external input) above is selected as an input to the valley switching block.
2. Configure the edge filter to capture 'n' rising, falling or both edges through the edge selection logic (DCFCTL[EDGEMODE, EDGECOUNT]).
3. Select the correct event to reset and restart the edge filter (VCAPCTL[TRIGSEL]). Edge capturing event is triggered or armed by this selected edge.
4. Enable valley capture logic (VCAPCTL[VCAPE]).
5. Select the start edge that will indicate the start of capture for oscillation period measurement (VCNTCFG[STARTEDGE]). This is where the 16-bit counter starts counting.
6. Select the stop edge (VCNTCFG[STOPEDGE]) that will indicate the edge at which the 16-bit counter stops counting. The captured counter value (CNTVAL) provides oscillation period information.
 - The STOPEDGE value must always be greater than STARTEDGE value.
7. Configure and apply the captured delay (CNTVAL) to the edge filtered DCxEVTy signal. The CNTVAL value may be applied as is or applied in conjunction with a software programmed value (useful for offset adjustment) (SWVDELVAL) or only a fraction of the delay may be applied with or without SWVDELVAL. This is useful to correctly apply a delay corresponding to the valley point. (VCAPCTL[VDELAYDIV])
8. Configure VCAPCTL[EDGEFILTDLYSEL] to apply hardware delay based on the captured value above.

Once the counter is stopped, counter value is copied into CNTVAL register and counter is reset to zero. No further captures are done until the logic is triggered again by occurrence of event selected by VCAPCTL[TRIGSEL]. In this implementation, the software trigger is used as the source for VCAPCTL[TRIGSEL]. Upon occurrence of the trigger event, irrespective of the current status of the counter, the counter is reset and starts counting from zero upon occurrence of the STARTEDGE. Similarly, upon occurrence of the trigger event, the edge filter is reset and starts counting from zero upon occurrence of the STARTEDGE.

Output from the valley switching block (DCEVTFILT) is then used to synchronize the PWM time-base. The process is shown in [Figure 7-156](#).

Note

A specific application example showcasing the usage of valley switching hardware and software is available on the controlSuite.

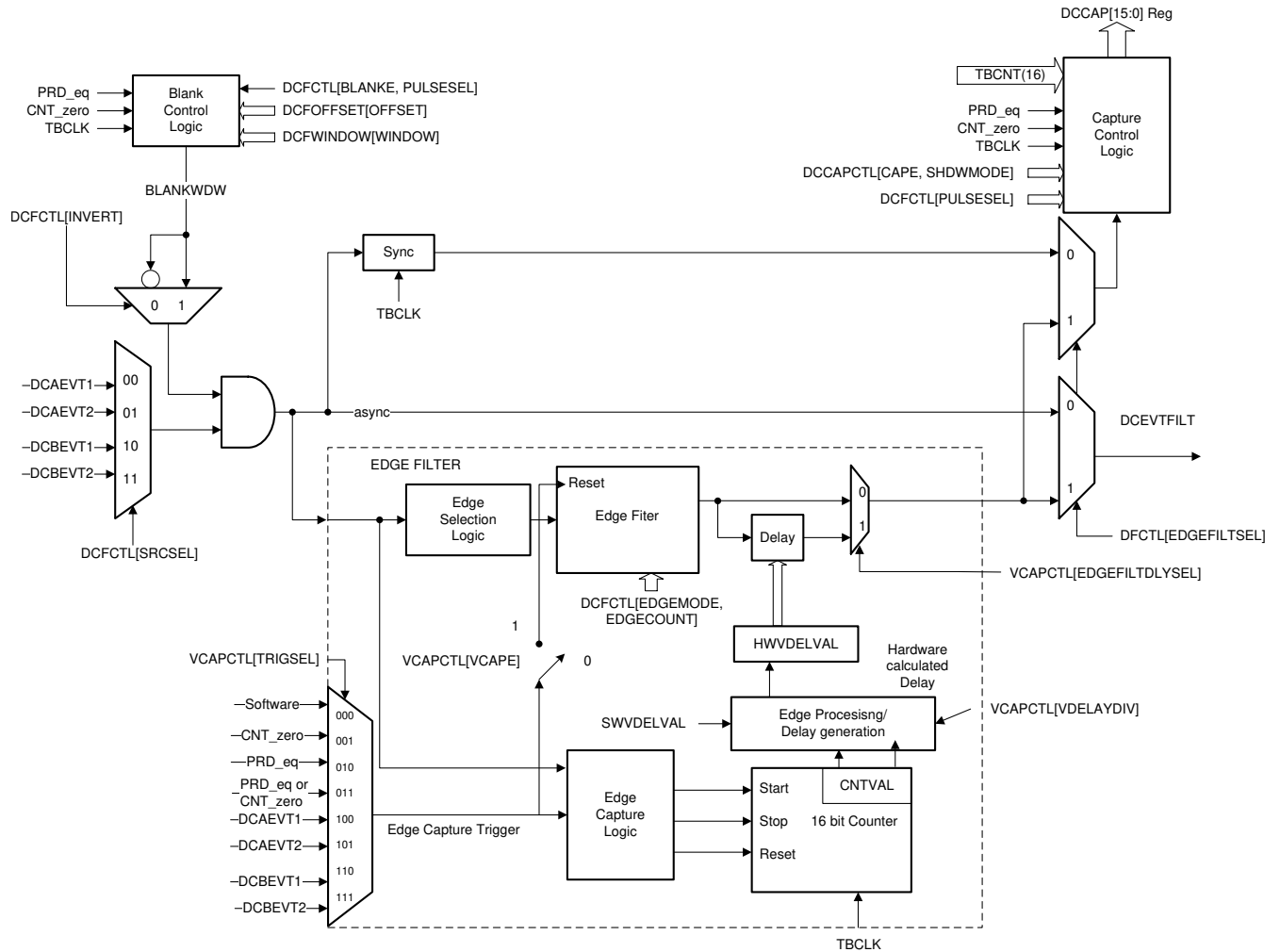

Figure 7-156. Valley Switching

7.4.5.13 PWMXBAR

See Section 7.4.10.2 for additional information regarding the EPWM Crossbar (XBAR) functionality.

ADVANCE INFORMATION

7.4.5.14 Applications to Power Topologies

An ePWM module has all the local resources necessary to operate completely as a standalone module or to operate in synchronization with other identical ePWM modules.

7.4.5.14.1 Overview of Multiple Modules

Previously in this chapter, all discussions have described the operation of a single module. To facilitate the understanding of multiple modules working together in a system, the ePWM module described in reference is represented by the more simplified block diagram shown in Figure 7-157. This simplified ePWM block shows only the key resources needed to explain how a multiswitch power topology is controlled with multiple ePWM modules working together.

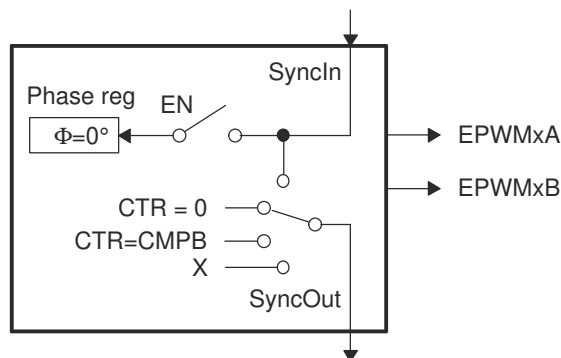

Figure 7-157. Simplified ePWM Module

7.4.5.14.2 Key Configuration Capabilities

The key configuration choices available to each module are as follows:

- Options for SyncIn
 - Load own counter with phase register on an incoming sync strobe—enable (EN) switch closed
 - Do nothing or ignore incoming sync strobe—enable switch open
 - Sync flow-through - SyncOut connected to SyncIn
 - Sync Source mode, provides a sync at PWM boundaries—SyncOut connected to CTR = PRD
 - Sync Source mode, provides a sync at any programmable point in time—SyncOut connected to CTR = CMPB
 - Module is in standalone mode and provides no sync to other modules—SyncOut connected to X (disabled)
- Options for SyncOut
 - Sync flow-through - SyncOut connected to SyncIn
 - Sync Source mode, provides a sync at PWM boundaries—SyncOut connected to CTR = PRD
 - Sync Source mode, provides a sync at any programmable point in time—SyncOut connected to CTR = CMPB
 - Module is in standalone mode and provides no sync to other modules—SyncOut connected to X (disabled)

For each choice of SyncOut, a module may also choose to load its own counter with a new phase value on a SyncIn strobe input or choose to ignore it (that is, by the enable switch). Although various combinations are possible, the two most common—Sync Source module and Sync Receiver module modes—are shown in [Figure 7-158](#).

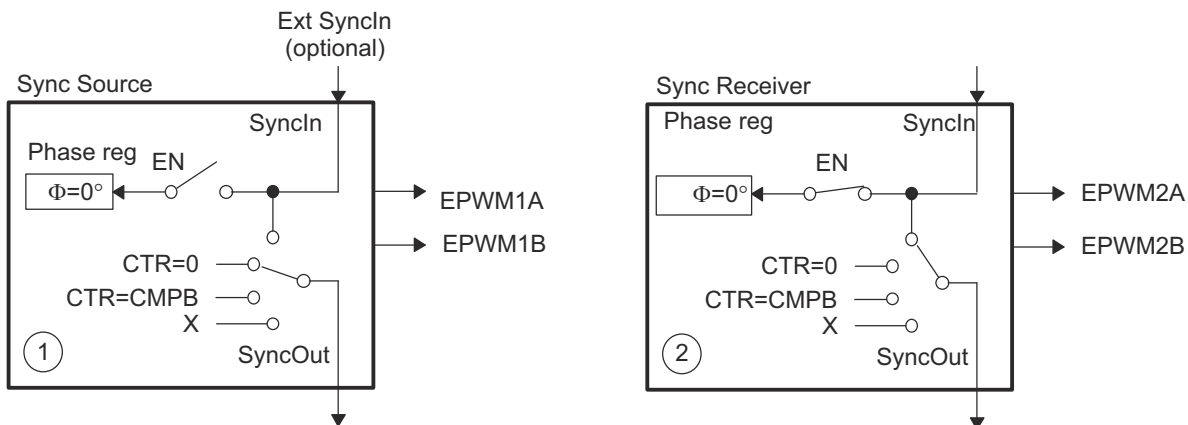
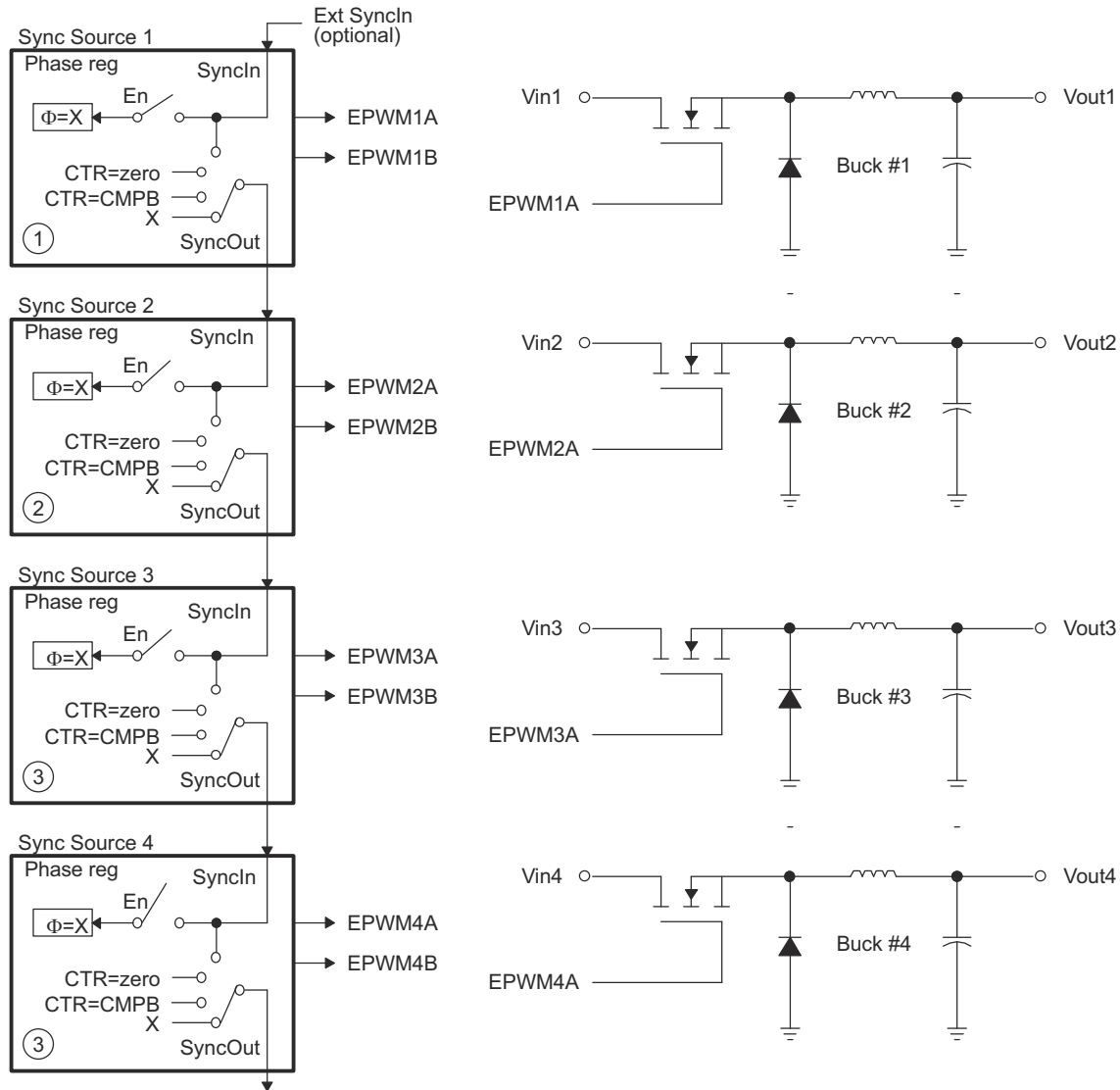

Figure 7-158. EPWM1 Configured as a Typical Sync Source, EPWM2 Configured as a Sync Receiver

7.4.5.14.3 Controlling Multiple Buck Converters With Independent Frequencies

One of the simplest power converter topologies is the buck. A single ePWM module configured as a sync source can control two buck stages with the same PWM frequency. If independent frequency control is required for each buck converter, then one ePWM module must be allocated for each converter stage. Figure 7-159 shows four buck stages, each running at independent frequencies. In this case, all four ePWM modules are configured as Sync Sources and no synchronization is used. Figure 7-160 shows the waveforms generated by the setup shown in Figure 7-159; note that only three waveforms are shown, although there are four stages.

ADVANCE INFORMATION



A. $\phi = X$ indicates value in phase register is a "don't care"

Figure 7-159. Control of Four Buck Stages. Here $F_{PWM1} \neq F_{PWM2} \neq F_{PWM3} \neq F_{PWM4}$

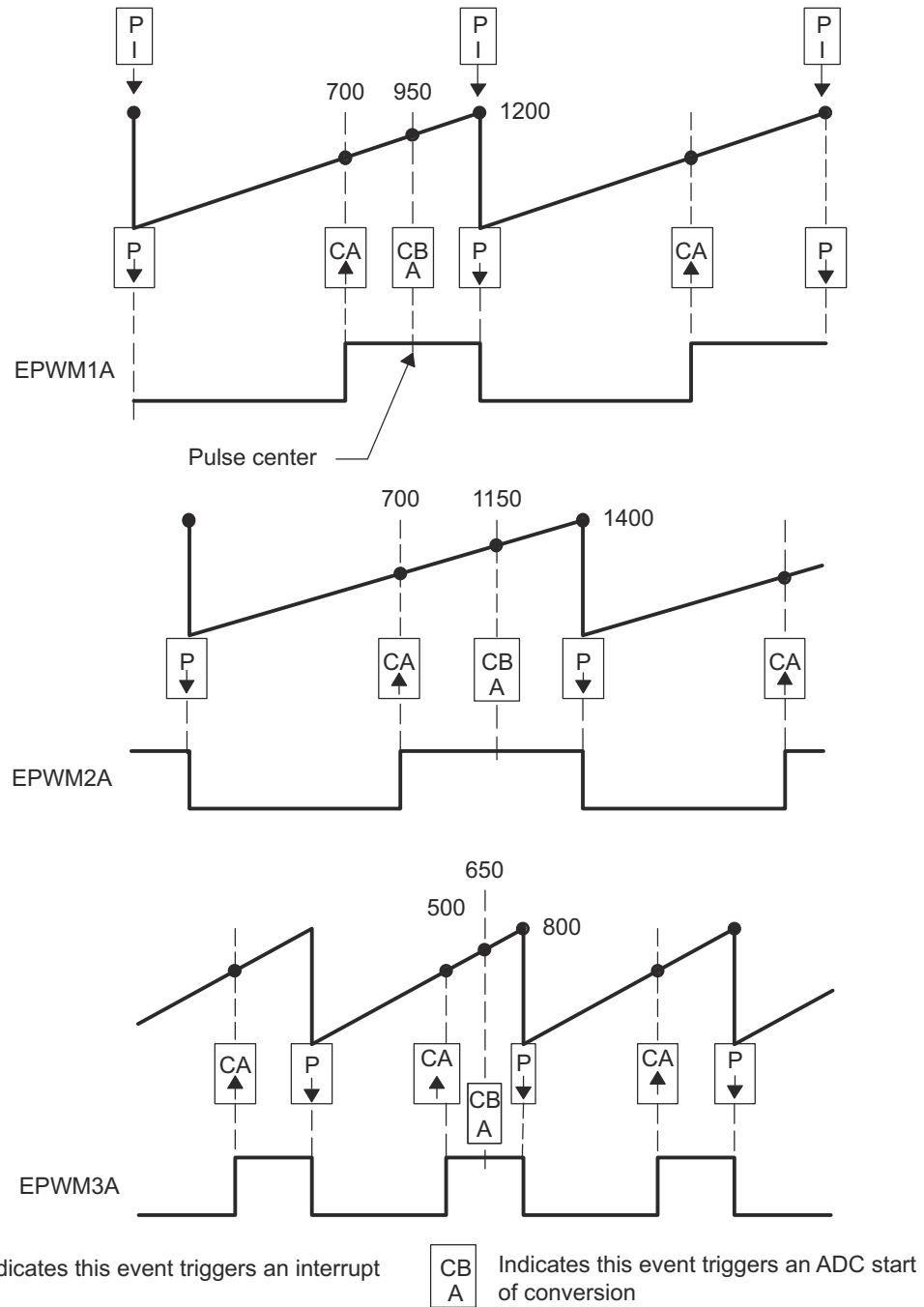
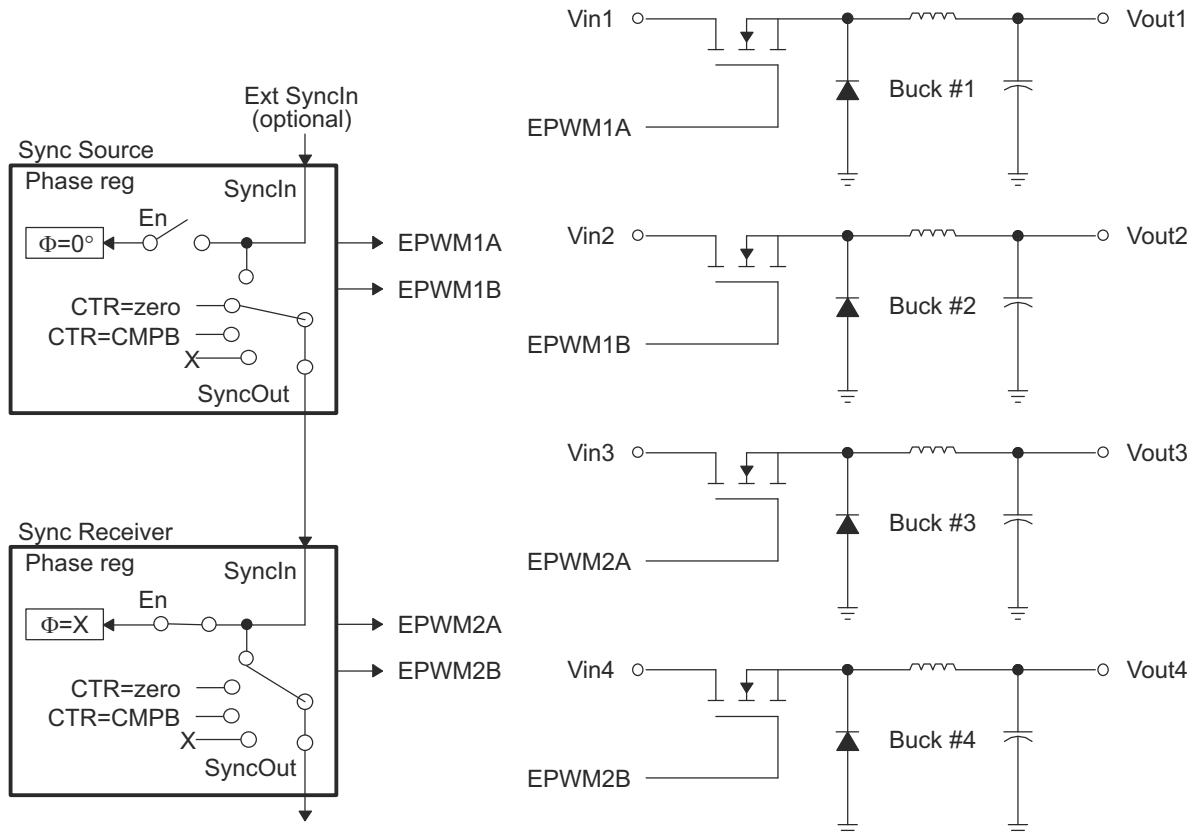

Figure 7-160. Buck Waveforms for Control of Four Buck Stages (Note: Only three bucks shown here)

7.4.5.14.4 Controlling Multiple Buck Converters With Same Frequencies

If synchronization is a requirement, ePWM module 2 is configured as a sync receiver and operates at integer multiple (N) frequencies of module 1. The sync signal from sync source to sync receiver ensures these modules remain locked. Figure 7-161 shows such a configuration; Figure 7-162 shows the waveforms generated by the configuration.

ADVANCE INFORMATION



A. $\phi = X$ indicates value in phase register is a "don't care"

Figure 7-161. Control of Four Buck Stages. (Note: $F_{PWM2} = N \times F_{PWM1}$)

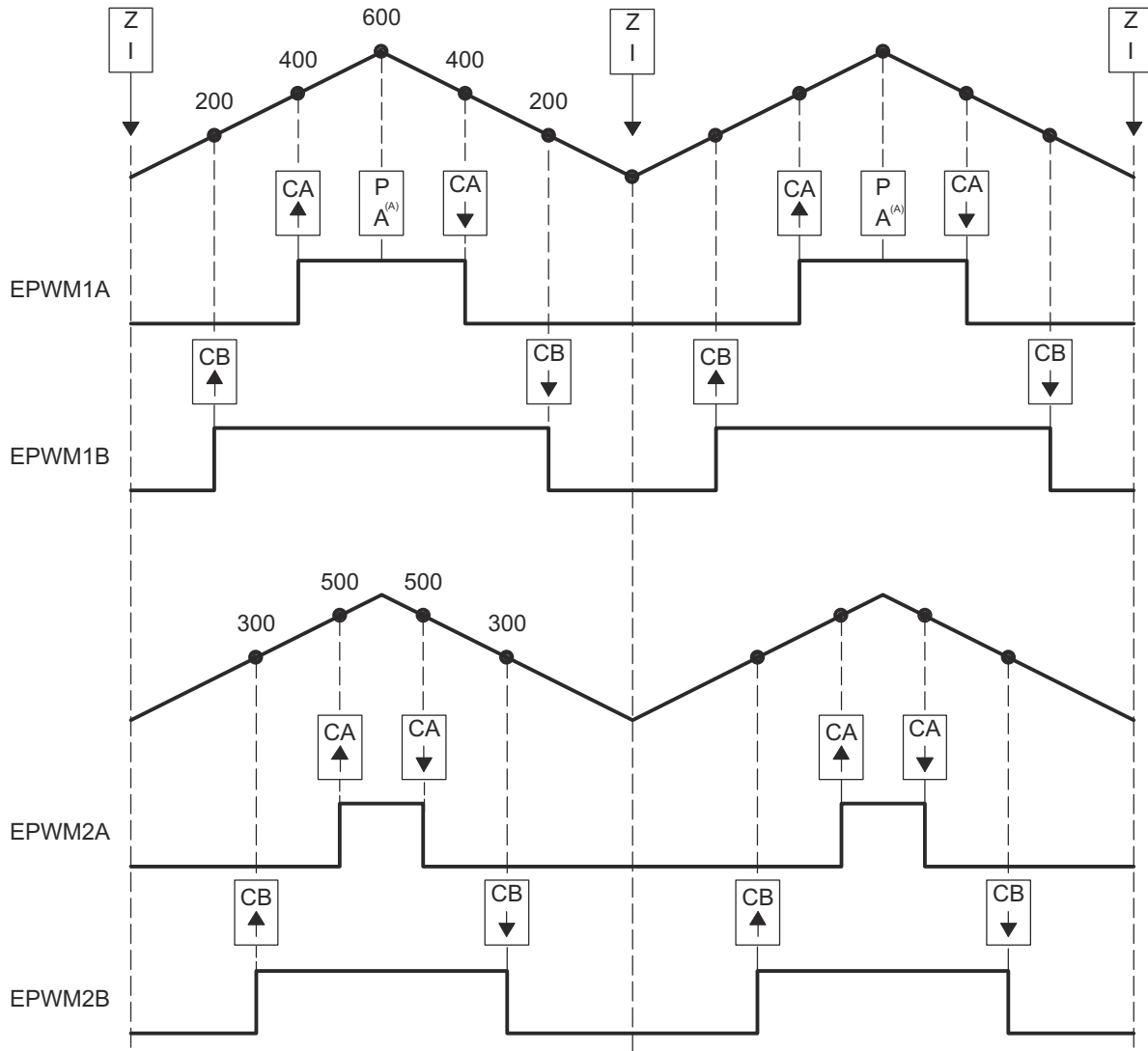

A. Starts ADC conversion.

Figure 7-162. Buck Waveforms for Control of Four Buck Stages (Note: $F_{PWM2} = F_{PWM1}$)

ADVANCE INFORMATION

7.4.5.14.5 Controlling Multiple Half H-Bridge (HHB) Converters

Topologies that require control of multiple switching elements can also be addressed with these same ePWM modules. It is possible to control a Half-H bridge stage with a single ePWM module. This control can be extended to multiple stages. Figure 7-163 shows control of two synchronized Half-H bridge stages where stage 2 can operate at integer multiple (N) frequencies of stage 1. Figure 7-164 shows the waveforms generated by the configuration shown in Figure 7-163.

ePWM module 2 (sync receiver) is configured for Sync flow-through; if required, this configuration allows for a third Half-H bridge to be controlled by ePWM module 3 and also, most importantly, to remain in synchronization with sync source ePWM module 1.

ADVANCE INFORMATION

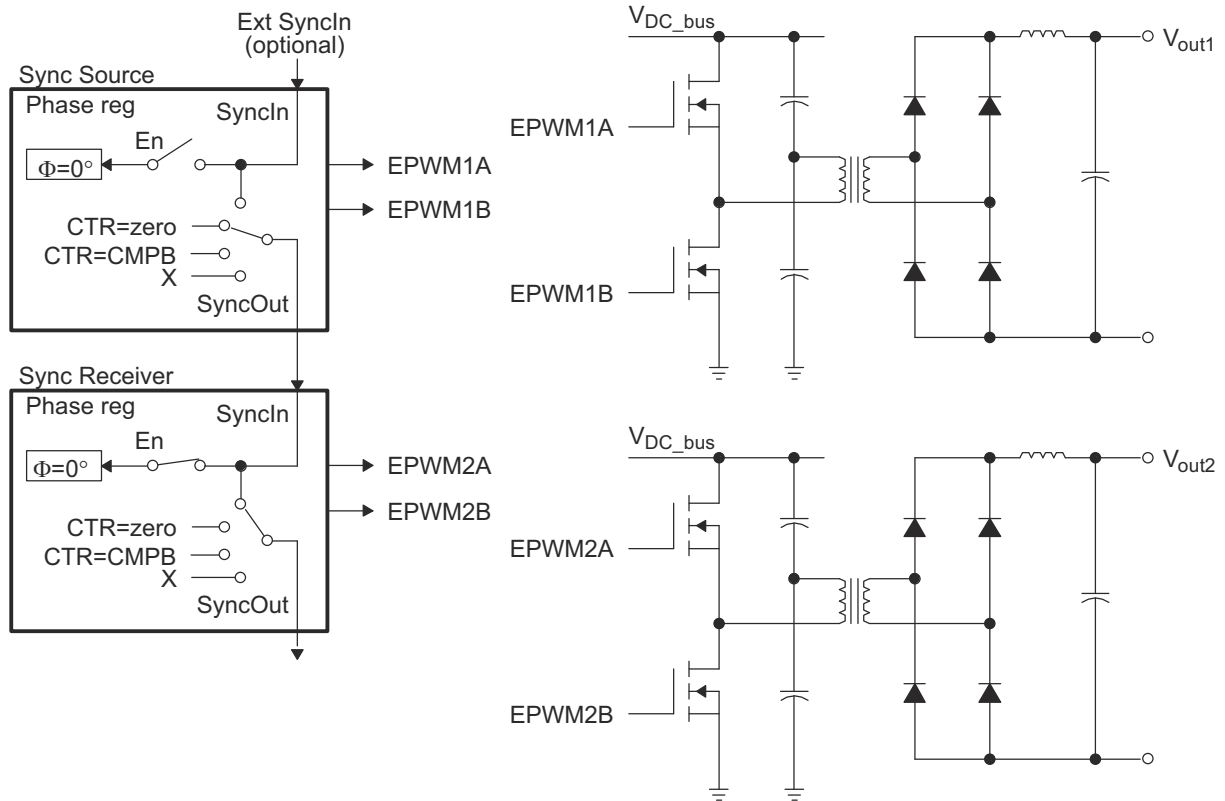

Figure 7-163. Control of Two Half-H Bridge Stages ($F_{PWM2} = N \times F_{PWM1}$)

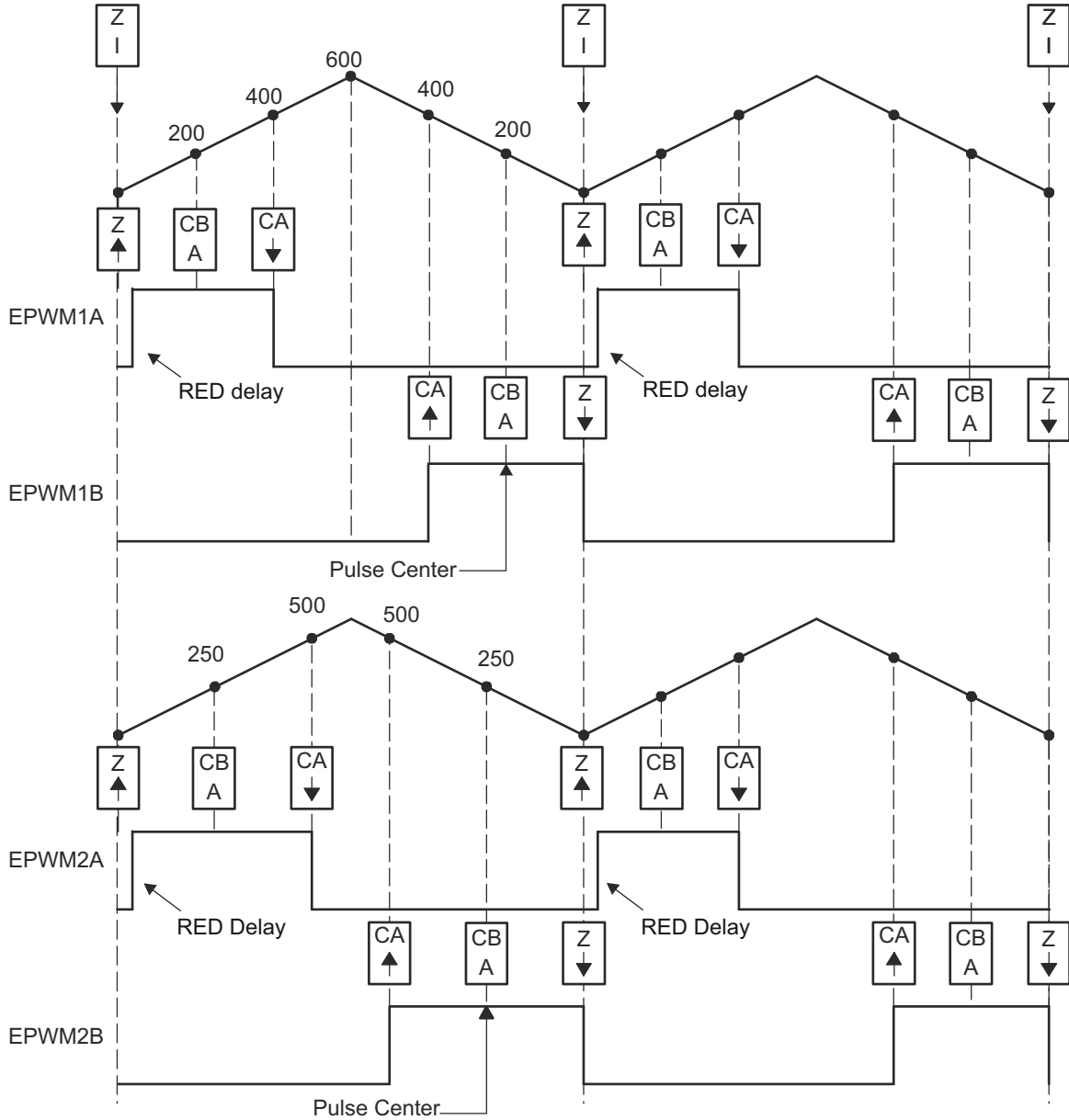

Figure 7-164. Half-H Bridge Waveforms for Control of Two Half-H Bridge Stages (Note: Here $F_{PWM2} = F_{PWM1}$)

ADVANCE INFORMATION

7.4.5.14.6 Controlling Dual 3-Phase Inverters for Motors (ACI and PMSM)

The idea of multiple modules controlling a single power stage can be extended to the 3-phase inverter case. In such a case, six switching elements are controlled using three PWM modules, one for each leg of the inverter. Each leg must switch at the same frequency and all legs must be synchronized. A sync source + two sync receivers configuration easily addresses this requirement. Figure 7-165 shows how six PWM modules control two independent 3-phase inverters; each running a motor.

As in the cases shown in the previous sections, we have a choice of running each inverter at a different frequency (module 1 and module 4 are sync sources as in Figure 7-165), or both inverters can be synchronized by using one sync source (module 1) and five sync receivers. In this case, the frequency of modules 4, 5, and 6 (all equal) can be integer multiples of the frequency for modules 1, 2, and 3 (also all equal).

ADVANCE INFORMATION

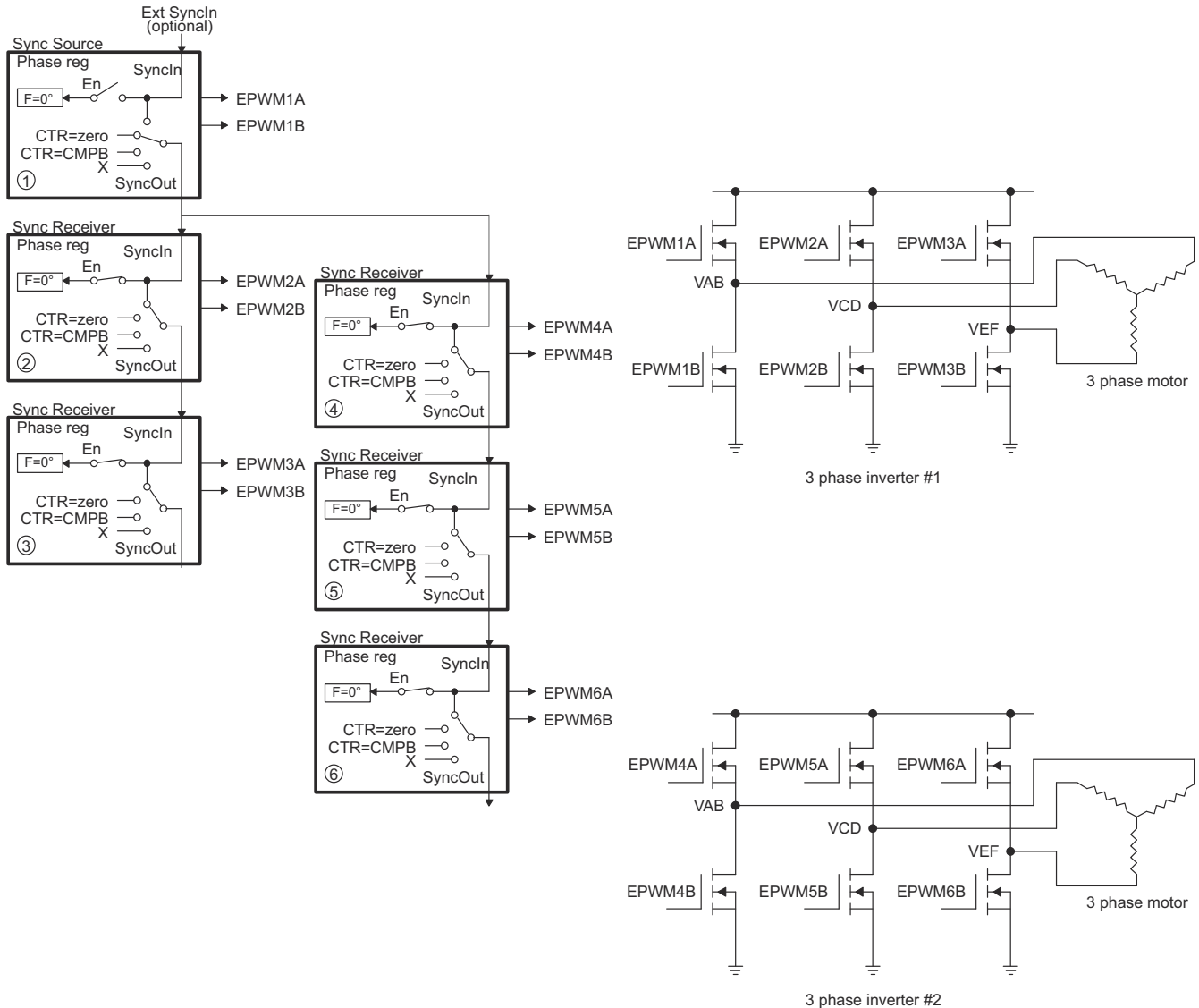
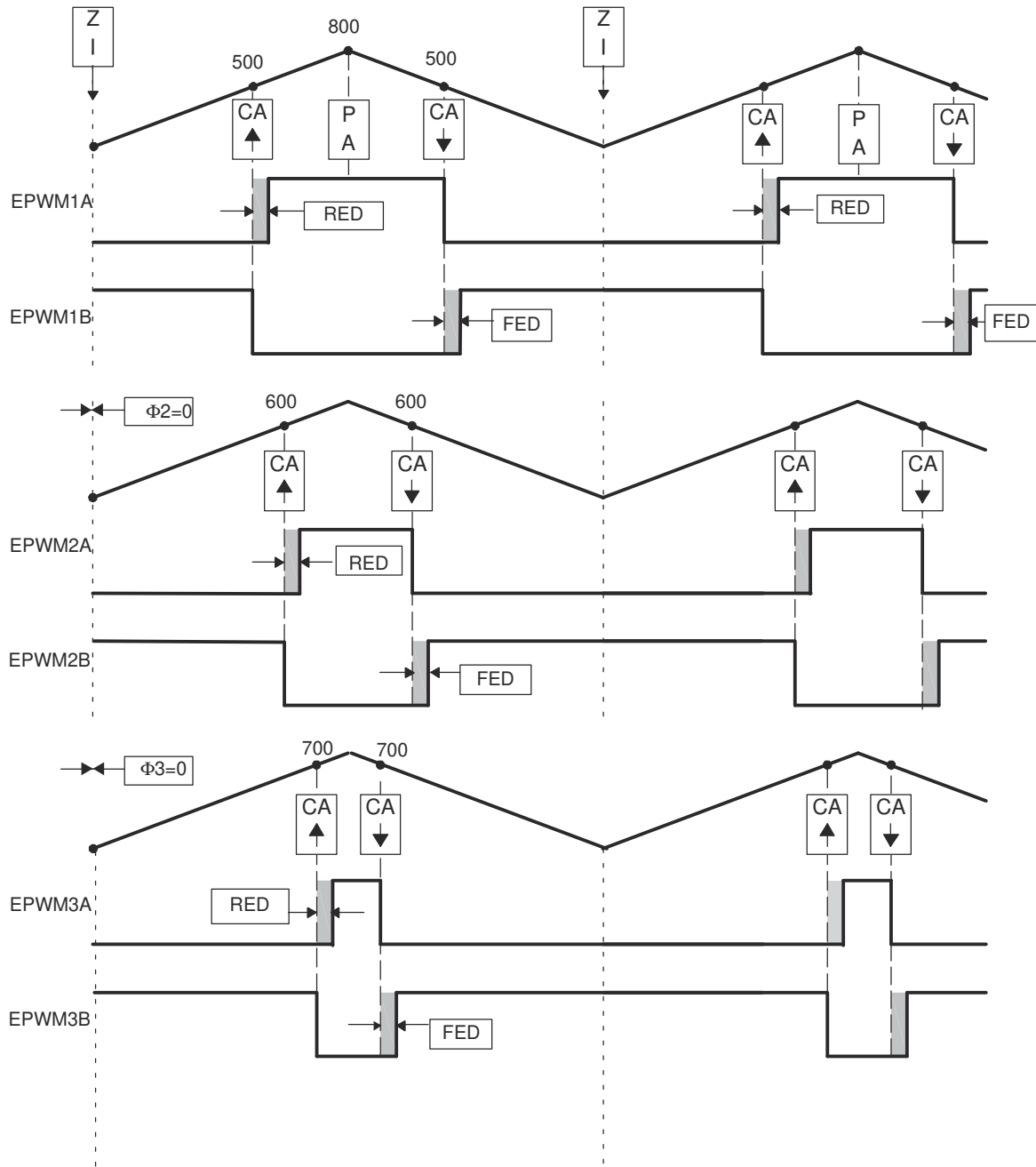

Figure 7-165. Control of Dual 3-Phase Inverter Stages as Is Commonly Used in Motor Control



ADVANCE INFORMATION

Figure 7-166. 3-Phase Inverter Waveforms for Control of Dual 3-Phase Inverter Stages (Only One Inverter Shown)

7.4.5.14.7 Practical Applications Using Phase Control Between PWM Modules

So far, none of the examples have made use of the phase register (TBPHS). It has either been set to zero or its value has been a don't care. However, by programming appropriate values into TBPHS, multiple PWM modules can address another class of power topologies that rely on phase relationship between legs (or stages) for correct operation. As described in the time-base submodule section, a PWM module can be configured to allow a SyncIn pulse to cause the TBPHS register to be loaded into the TBCTR register. To illustrate this concept, [Figure 7-167](#) shows a sync source and sync receiver module with a phase relationship of 120° (that is, the sync receiver leads the sync source).

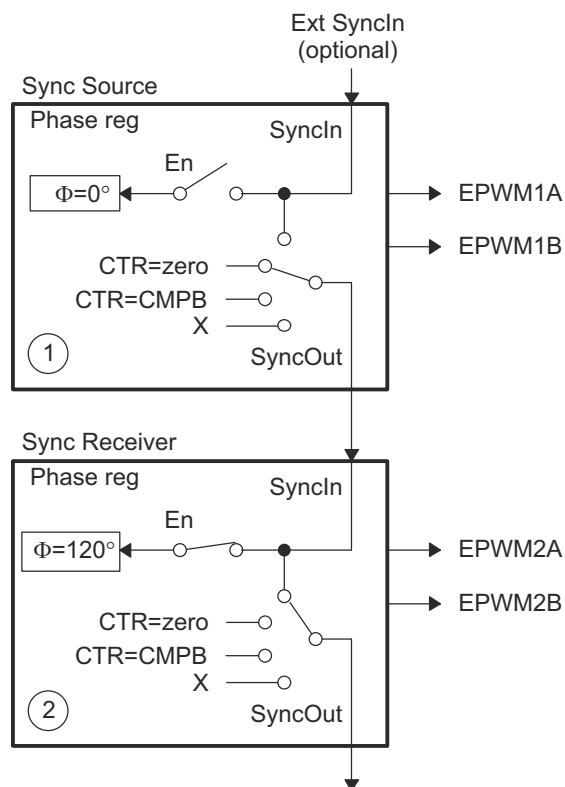

Figure 7-167. Configuring Two PWM Modules for Phase Control

[Figure 7-168](#) shows the associated timing waveforms for this configuration. Here, TBPRD = 600 for both sync source and sync receiver. For the sync receiver, TBPHS = 200 (that is, $200/600 \times 360^\circ = 120^\circ$). Whenever the sync source generates a SyncIn pulse (CTR = PRD), the value of TBPHS = 200 is loaded into the sync receiver TBCTR register so the sync receiver time-base is always leading the sync source time-base by 120°.

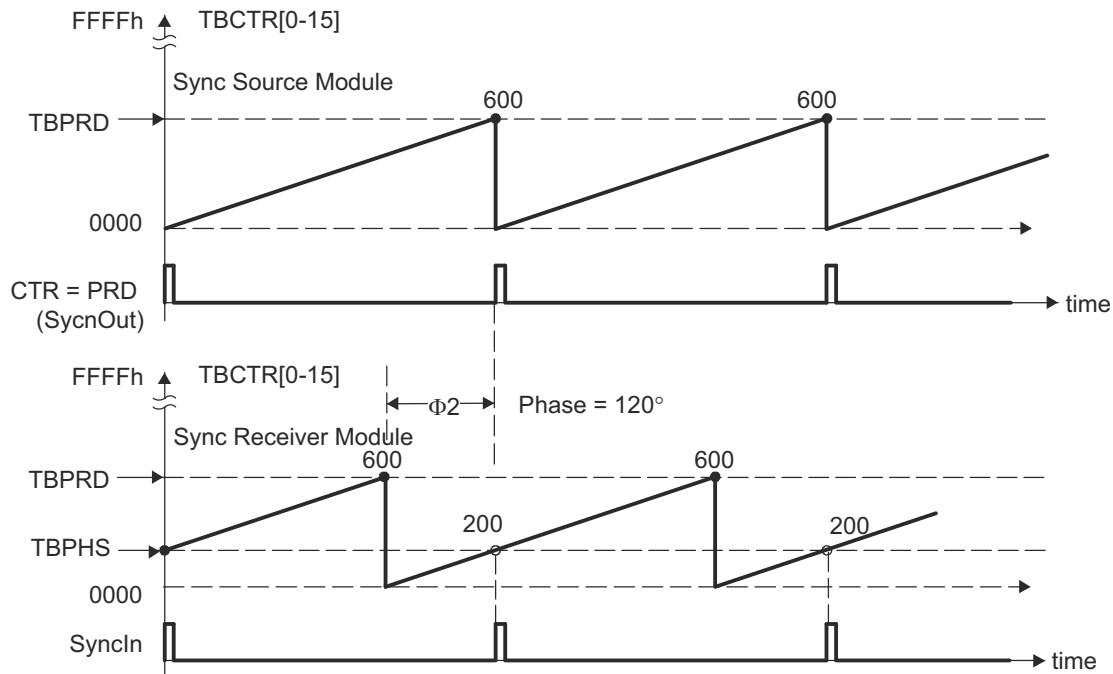

Figure 7-168. Timing Waveforms Associated With Phase Control Between Two Modules

7.4.5.14.8 Controlling a 3-Phase Interleaved DC/DC Converter

A popular power topology that makes use of phase-offset between modules is shown in Figure 7-169. This system uses three PWM modules, with module 1 configured as the sync source. To work, the phase relationship between adjacent modules must be $F = 120^\circ$. This is achieved by setting the sync receiver TBPHS registers 2 and 3 with values of 1/3 and 2/3 of the period value, respectively. For example, if the period register is loaded with a value of 600 counts, then TBPHS (sync receiver 2) = 200 and TBPHS (sync receiver 3) = 400. Both sync receiver modules are synchronized to the sync source module 1.

This concept can be extended to four or more phases, by setting the TBPHS values appropriately. The following formula gives the TBPHS values for N phases:

$$TBPHS(N,M) = (TBPRD/N) \times (M-1)$$

Where:

N = number of phases

M = PWM module number

For example, for the 3-phase case (N=3), TBPRD = 600,

$TBPHS(3,2) = (600/3) \times (2-1) = 200$ (that is, Phase value for Sync Receiver module 2)

$TBPHS(3,3) = 400$ (that is, Phase value for Sync Receiver module 3)

Figure 7-170 shows the waveforms for the configuration in Figure 7-169.

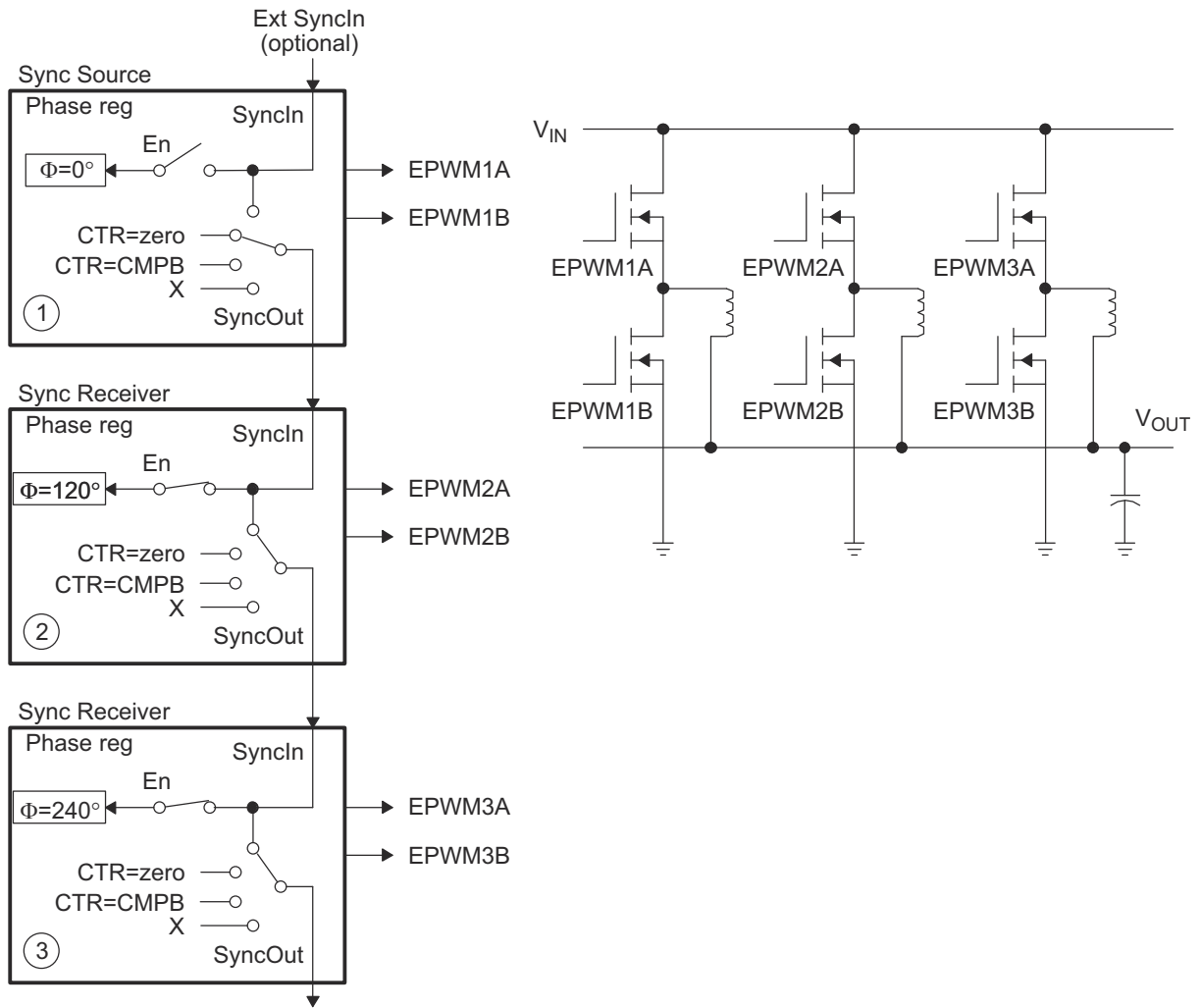
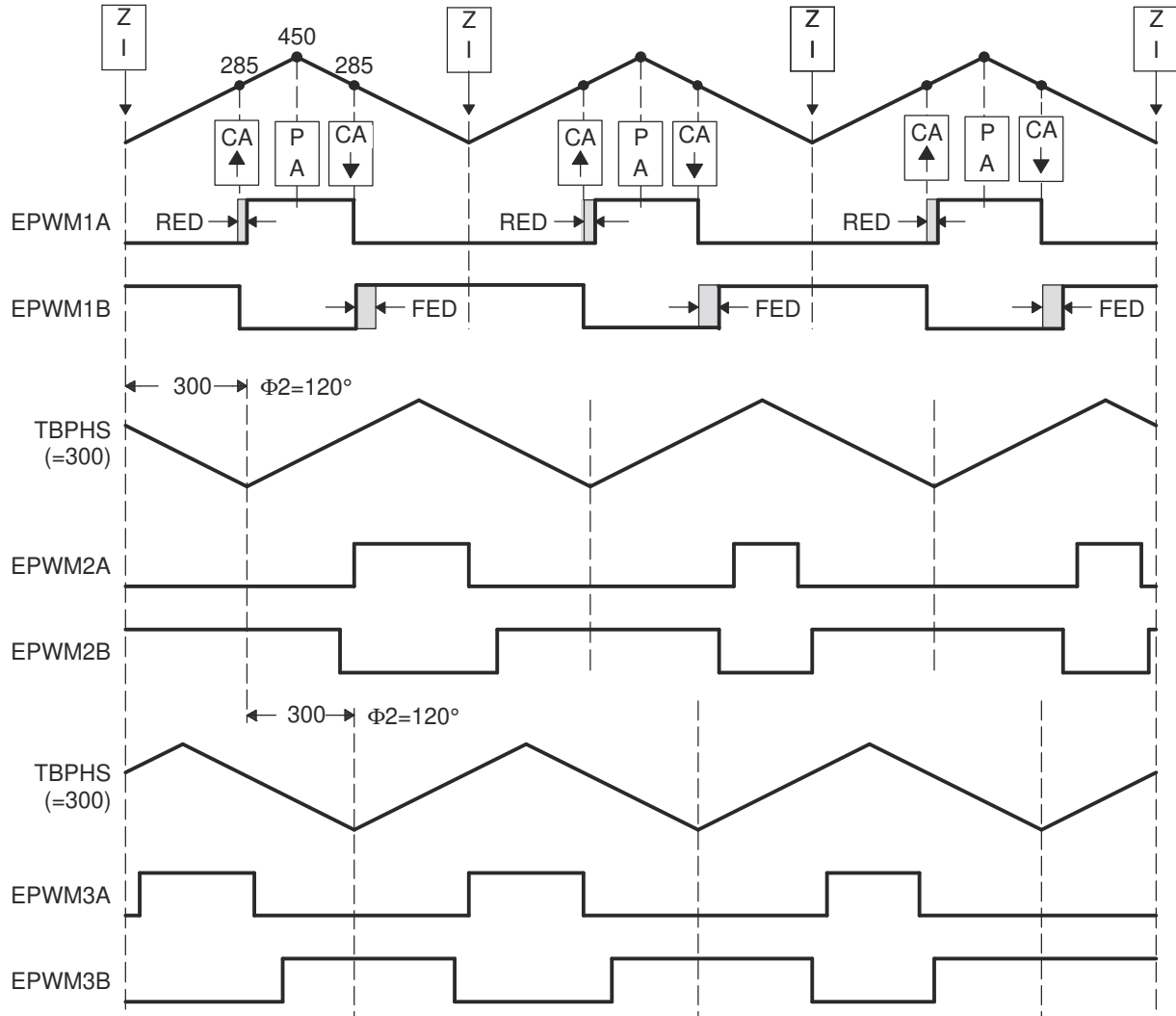

Figure 7-169. Control of 3-Phase Interleaved DC/DC Converter



ADVANCE INFORMATION

Figure 7-170. 3-Phase Interleaved DC/DC Converter Waveforms for Control of 3-Phase Interleaved DC/DC Converter

7.4.5.14.9 Controlling Zero Voltage Switched Full Bridge (ZVSFB) Converter

The example given in [Figure 7-171](#) assumes a static or constant phase relationship between legs (modules). In such a case, control is achieved by modulating the duty cycle. It is also possible to dynamically change the phase value on a cycle-by-cycle basis. This feature lends itself to controlling a class of power topologies known as *phase-shifted full bridge*, or *zero voltage switched full bridge*. Here the controlled parameter is not duty cycle (this is kept constant at approximately 50 percent); instead it is the phase relationship between legs. Such a system can be implemented by allocating the resources of two PWM modules to control a single power stage, which in turn requires control of four switching elements. [Figure 7-172](#) shows a sync source and sync receiver module combination synchronized together to control a full H-bridge. In this case, both sync source and sync receiver modules are required to switch at the same PWM frequency. The phase is controlled by using the sync receiver phase register (TBPHS). The sync source phase register is not used and therefore can be initialized to zero.

ADVANCE INFORMATION

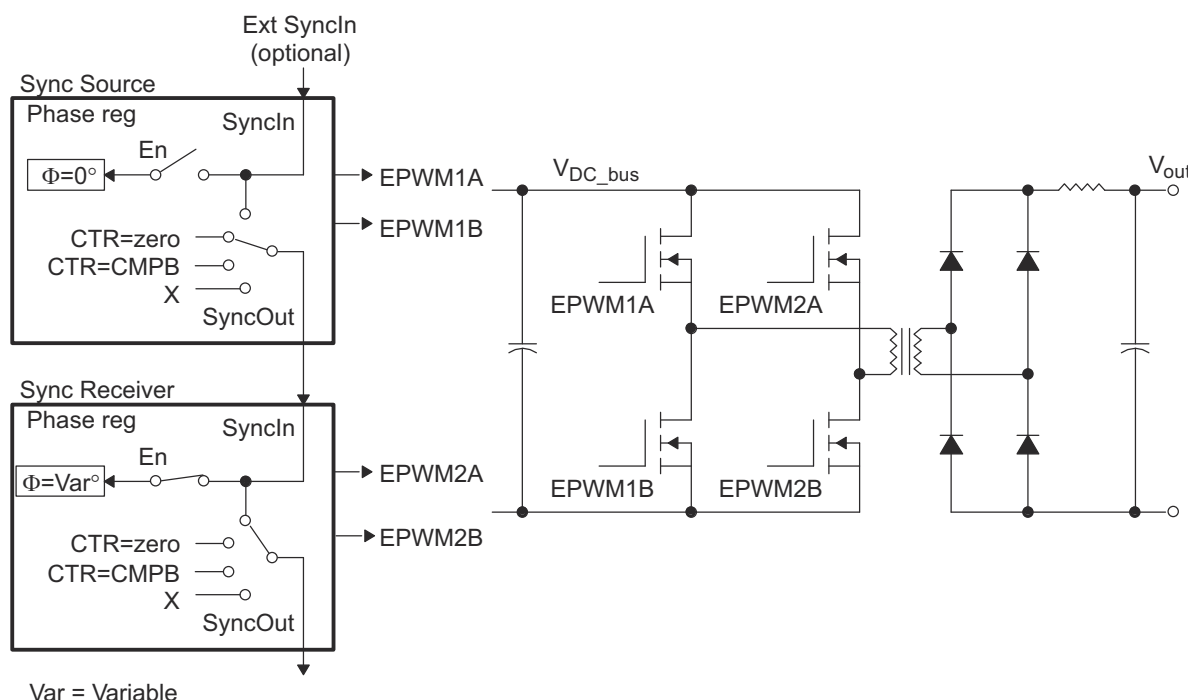

Figure 7-171. Control of Full-H Bridge Stage ($F_{PWM2} = F_{PWM1}$)

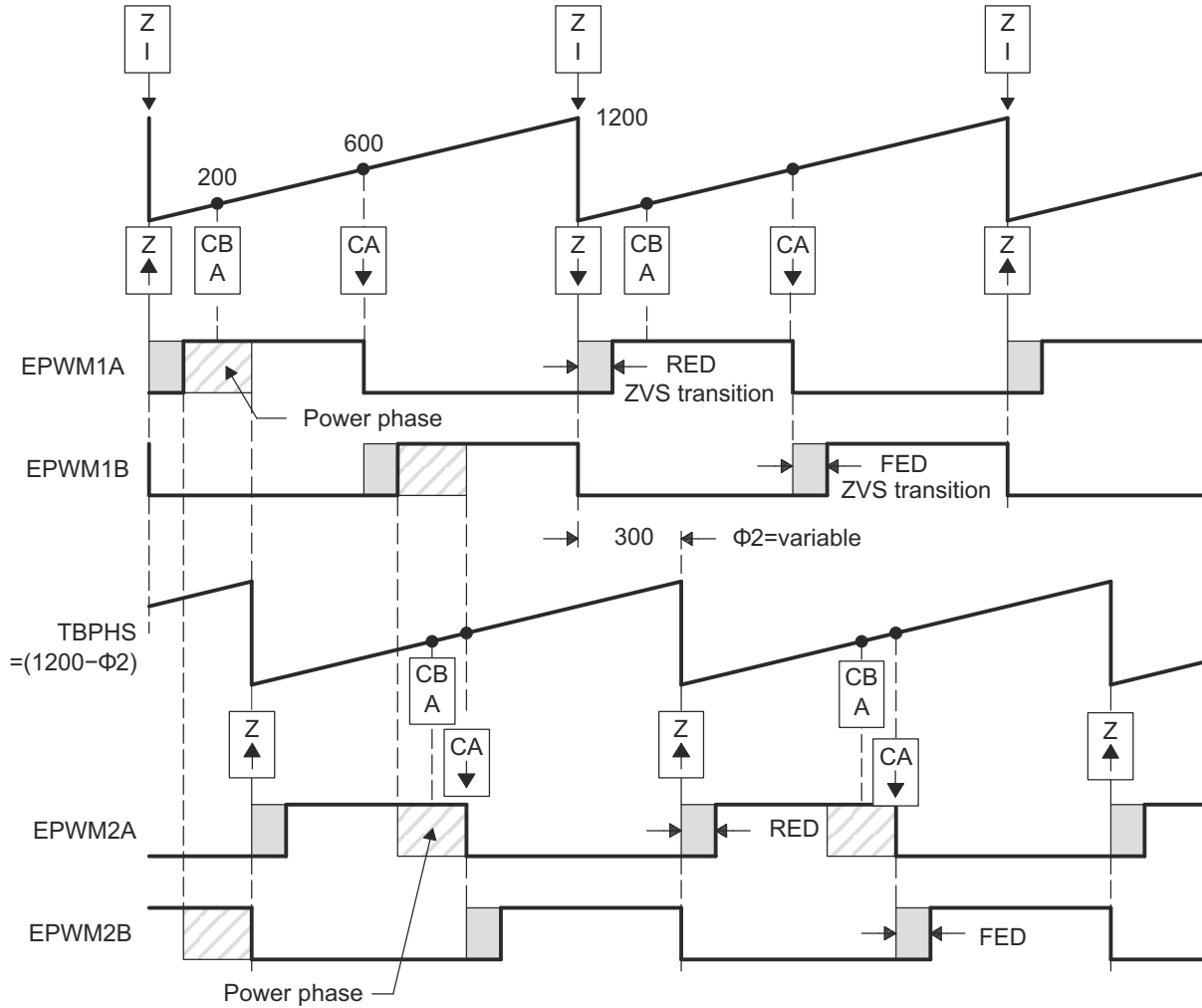

Figure 7-172. ZVS Full-H Bridge Waveforms

ADVANCE INFORMATION

7.4.5.14.10 Controlling a Peak Current Mode Controlled Buck Module

Peak current control techniques offer a number of benefits like automatic over current limiting, fast correction for input voltage variations and reducing magnetic saturation. Figure 7-173 shows the use of ePWM1A along with the on-chip analog comparator for buck converter topology. The output current is sensed through a current sense resistor and fed to the positive terminal of the on-chip comparator. The internal programmable 12-bit DAC can be used to provide a reference peak current at the negative terminal of the comparator. Alternatively, an external reference could be connected at this input. The comparator output is an input to the Digital compare sub-module. The ePWM module is configured in such a way so as to trip the ePWM1A output as soon as the sensed current reaches the peak reference value. A cycle-by-cycle trip mechanism is used. Figure 7-174 shows the waveforms generated by the configuration.

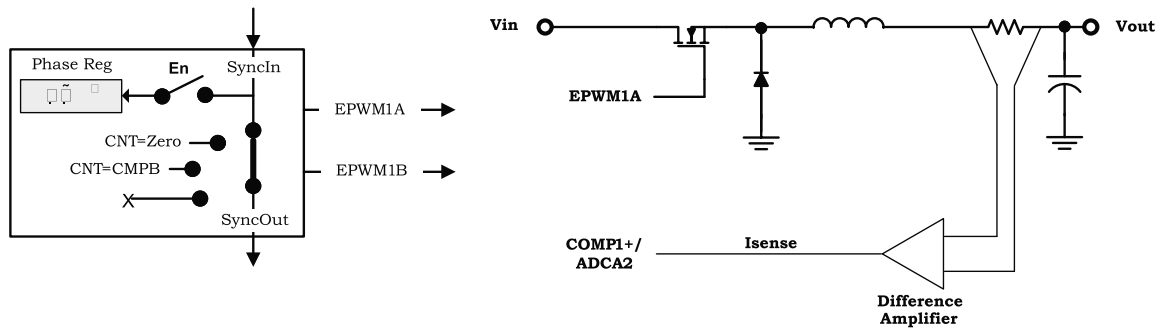

Figure 7-173. Peak Current Mode Control of Buck Converter

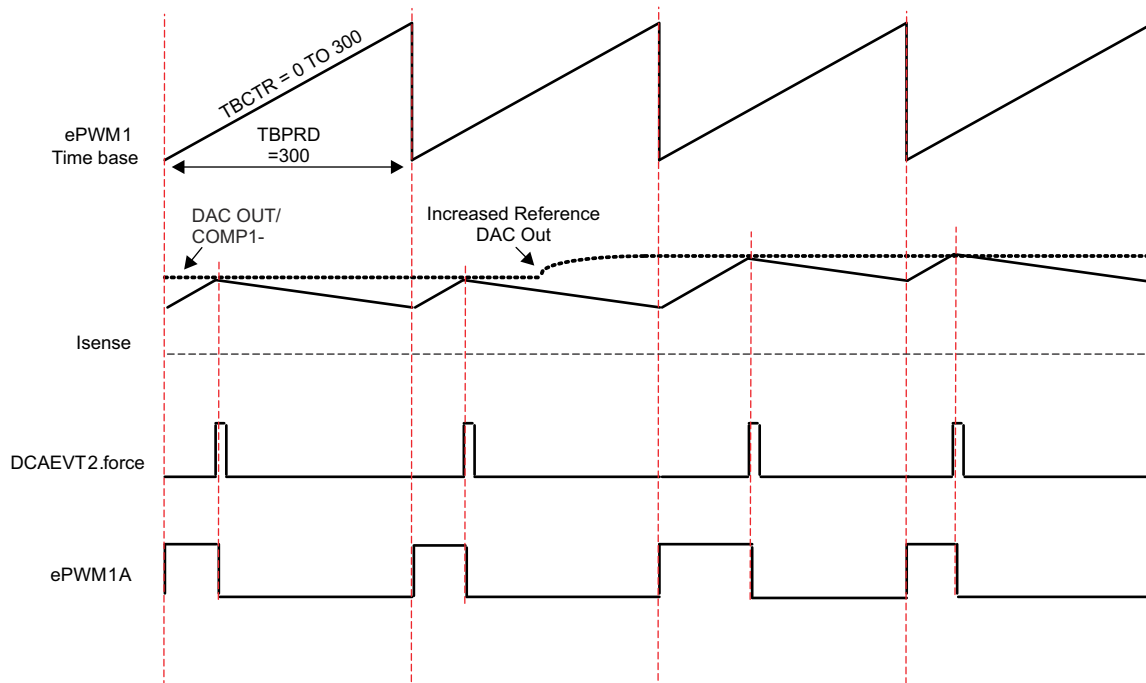
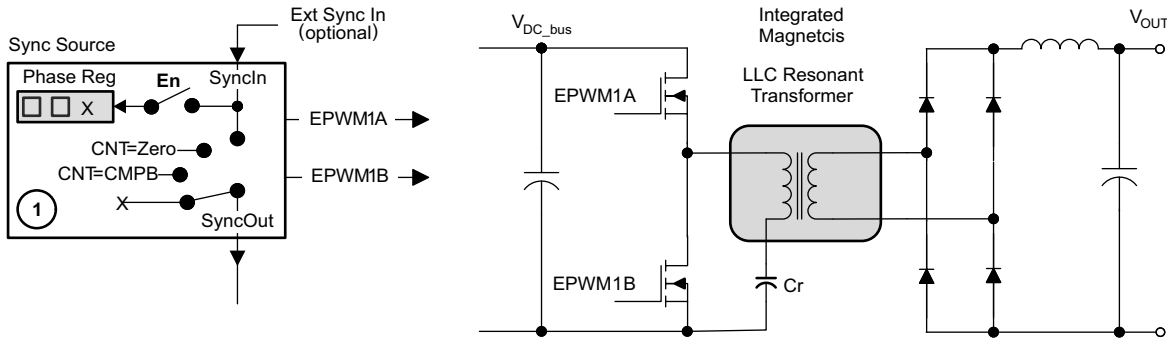

Figure 7-174. Peak Current Mode Control Waveforms for Control of Buck Converter

ADVANCE INFORMATION

7.4.5.14.11 Controlling H-Bridge LLC Resonant Converter

Various topologies of resonant converters are well-known in the field of power electronics for many years. In addition to these, H-bridge LLC resonant converter topology has recently gained popularity in many consumer electronics applications where high efficiency and power density are required. In this example, single channel configuration of ePWM1 is detailed, yet the configuration can easily be extended to multichannel. Here the controlled parameter is not duty cycle (this is kept constant at approximately 50 percent); instead it is frequency. Although the deadband is not controlled and kept constant as 300 ns (that is, 30 at 100 MHz TBCLK), it is up to you to update it in real time to enhance the efficiency by adjusting enough time delay for soft switching.



NOTE $\Theta = X$ indicates value in phase register is a "don't care"

Figure 7-175. Control of Two Resonant Converter Stages

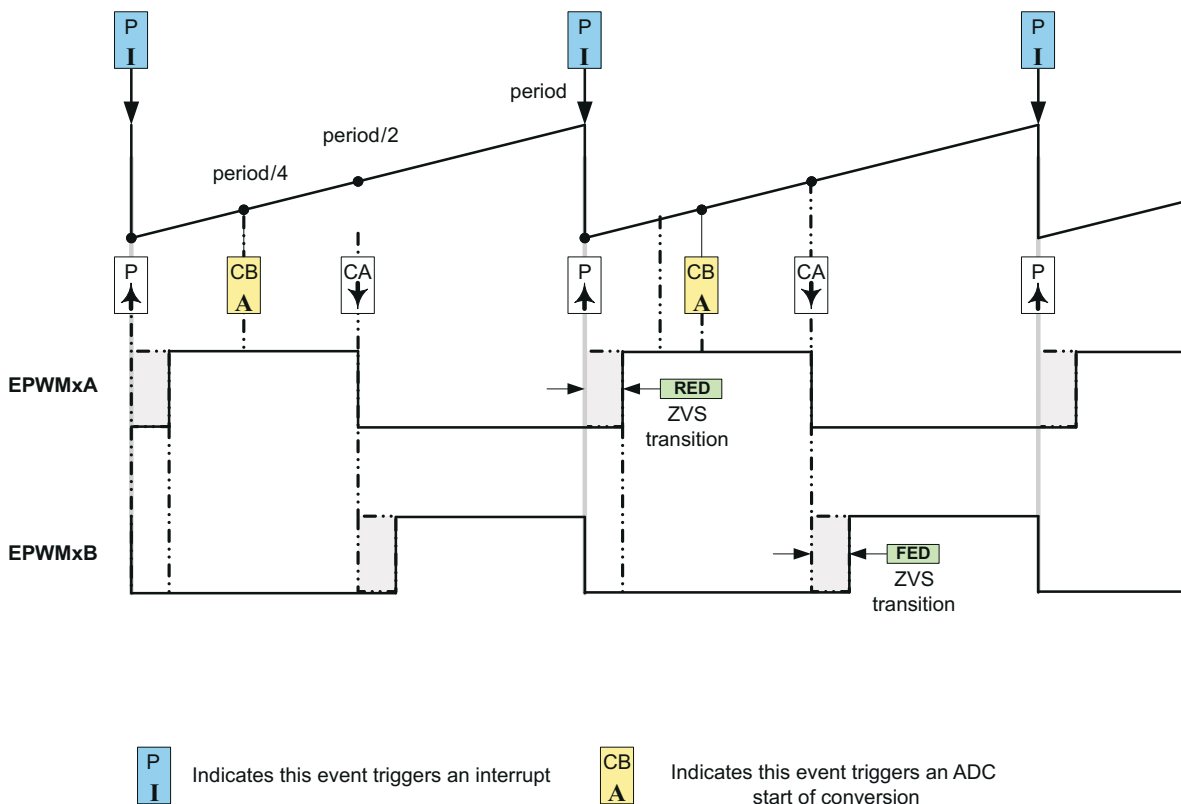

P I Indicates this event triggers an interrupt **CB A** Indicates this event triggers an ADC start of conversion

Figure 7-176. H-Bridge LLC Resonant Converter PWM Waveforms

ADVANCE INFORMATION

7.4.5.15 Register Lock Protection

The register lock protection mechanism is added to protect the critical ePWM registers from being corrupted by accidental writes in case of runaway code. The register EPWMLOCK contains the definition of Lock bits (Table 7-120 shows the lock bits and the corresponding registers). This register also has a KEY field; writes to this register will succeed only if the KEY field is written with a value of 0xa5a5. Refer to the register descriptions for more details.

Table 7-120. Lock Bits and Corresponding Registers

Bit Field	Definition	Registers Locked
HRLOCK	HRPWM Register Set Lock	HRCNFG, HRPWR, HRMSTEP, HRPCTL
GLLOCK	Global Load Register Set Lock	GLDCTL, GLDCFG
TZCFGLOCK	TripZone Register Set Lock	TZSEL, TZDSEL, TZCTL, TZCTL2, TZCTLDCA, TZCTLDCB, TZEINT
TZCLRLOCK	TripZone Clear Register Set Lock	TZCLR, TZCBCCLR, TZOSTCLR, TZFRC
DCLOCK	Digital Compare Register Set Lock	DCTRIPSEL, DCACTL, DCBCTL, DCFCTL, DCCAPCTL, DCAHTRIPSEL, DCALTRIPSEL, DCBHTRIPSEL, DCBLTRIPSEL

Note

Due to the presence of the KEY field in the same register, only 32-bit writes will succeed if the KEY matches. The 16-bit writes to the upper or lower half of this register will be ignored.

7.4.5.16 High-Resolution Pulse Width Modulator (HRPWM)

Figure 7-177 shows a block diagram of the HRPWM. This module extends the time resolution capabilities of the conventionally derived digital pulse width modulator (PWM). HRPWM is typically used when PWM resolution falls below ~ 9-10 bits. The key features of HRPWM are:

- Extended time resolution capability
- Used in both duty cycle and phase-shift control methods
- Finer time granularity control or edge positioning using extensions to the Compare A, Compare B and Phase registers
- Implemented using the A and B signal path of PWM, that is, on the EPWMxA and EPWMxB output
- Dead band high-resolution control for falling and rising edge delay in half cycle clocking operation
- Self-check diagnostics software mode to check if the micro edge positioner (MEP) logic is running optimally
- Enables high resolution output swapping on the EPWMxA and EPWMxB output
- Enables high-resolution output on EPWMxB signal output via inversion of EPWMxA signal output
- Enables high-resolution period, duty and phase control on the EPWMxA and EPWMxB output on devices with an ePWM module

Note

See the device-specific datasheet to determine if your device has an ePWM module with high-resolution period support.

Note

The AM263x platform **does not support** high-resolution output swapping on the EPWMxA and EPWMxB output or use of the OUT_SWAP register bit.

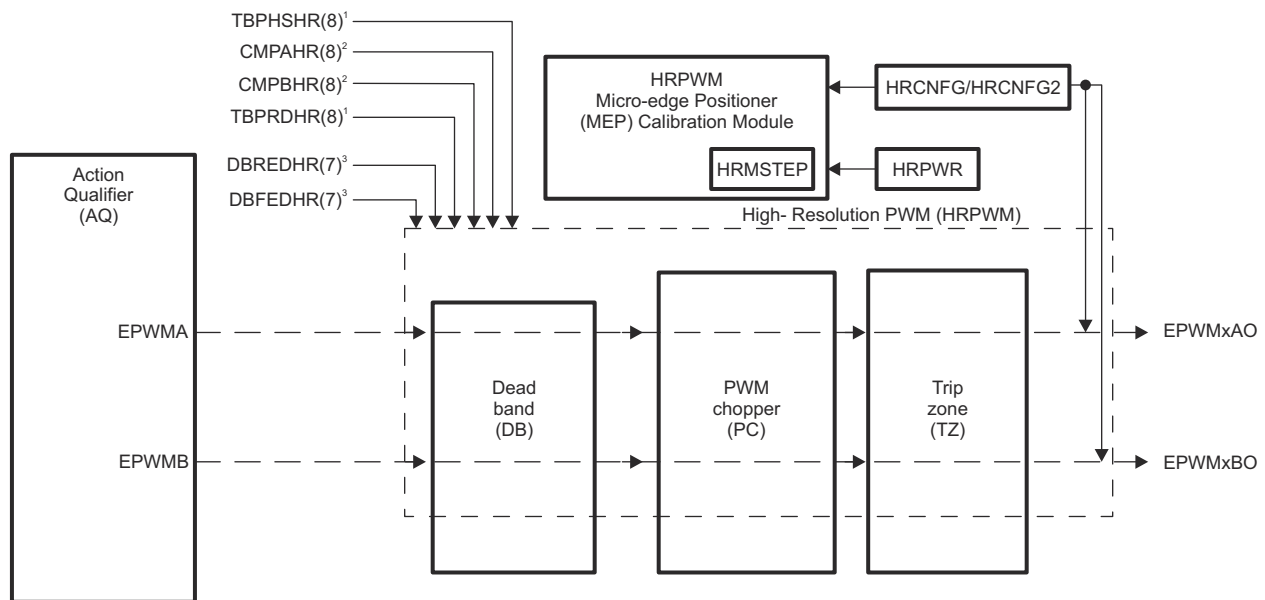

- A. From ePWM Time-base (TB) submodule
- B. From ePWM counter-compare (CC) submodule
- C. From ePWM Deadband (DB) submodule

Figure 7-177. HRPWM Block Diagram

The ePWM peripheral is used to perform a function mathematically equivalent to a digital-to-analog converter (DAC). As shown in Figure 7-178, the effective resolution for conventionally generated PWM is a function of PWM frequency (or period) and system clock frequency.

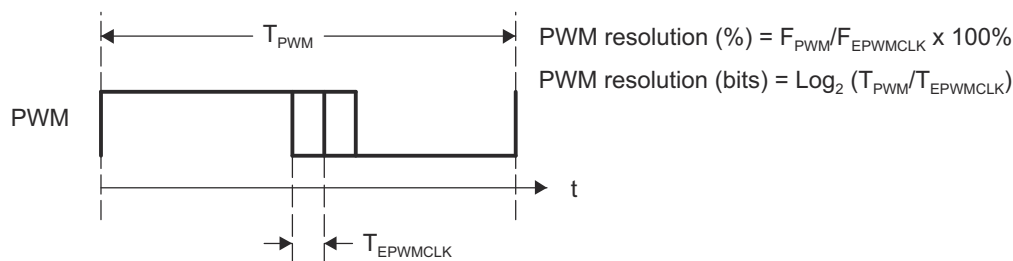

Figure 7-178. Resolution Calculations for Conventionally Generated PWM

If the required PWM operating frequency does not offer sufficient resolution in PWM mode, you may want to consider HRPWM. As an example of improved performance offered by HRPWM, Table 7-121 shows resolution in bits for various PWM frequencies. These values assume a MEP step size of 180 ps. See the device-specific data sheet for typical and maximum performance specifications for the MEP.

Table 7-121. Resolution for PWM and HRPWM

PWM Frequency (kHz)	Regular Resolution (PWM) 100 MHz EPWMCLK		High Resolution (HRPWM)	
	Bits	%	Bits	%
20	12.3	0.02	18.1	0.000
50	11	0.05	16.8	0.001
100	10	0.1	15.8	0.002
150	9.4	0.15	15.2	0.003
200	9	0.2	14.8	0.004
250	8.6	0.25	14.4	0.005
500	7.6	0.5	13.4	0.009
1000	6.6	1	12.4	0.018
1500	6.1	1.5	11.9	0.027
2000	5.6	2	11.4	0.036

Although each application may differ, typical low frequency PWM operation (below 250 kHz) may not require HRPWM. HRPWM capability is most useful for high frequency PWM requirements of power conversion topologies such as:

- Single-phase buck, boost, and flyback
- Multi-phase buck, boost, and flyback
- Phase-shifted full bridge
- Direct modulation of D-Class power amplifiers

7.4.5.16.1 Operational Description of HRPWM

The HRPWM is based on micro-edge positioner (MEP) technology. MEP logic is capable of positioning an edge very finely by sub-dividing one coarse system clock of a conventional PWM generator. The time step accuracy is on the order of 150 ps. See the device-specific data sheet for the typical MEP step size on a particular device. The HRPWM also has a self-check software diagnostics mode to check if the MEP logic is running optimally, under all operating conditions. Details on software diagnostics and functions are in [Section 7.4.5.16.1.7](#).

Figure 7-179 shows the relationship between one coarse system clock and edge position in terms of MEP steps, which are controlled via an 8-bit field in the Compare A extension register (CMPAHR). The same operating logic applies to CMPBHR as well.

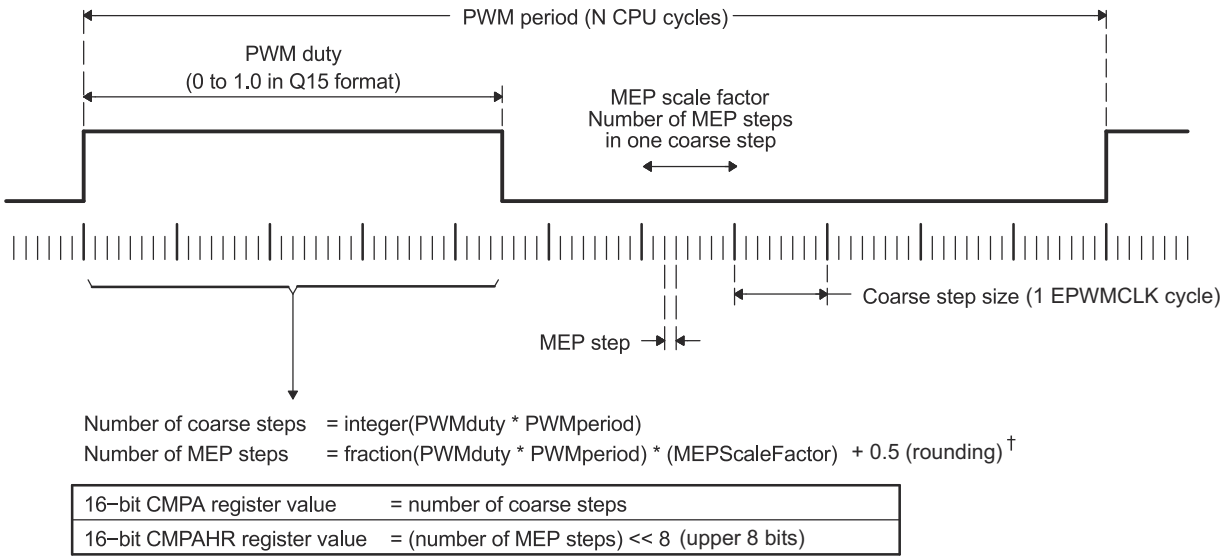

† For MEP range and rounding adjustment. (0x0080 in Q8 format)

Figure 7-179. Operating Logic Using MEP

To generate an HRPWM waveform, configure the ePWM registers as you would to generate a conventional PWM of a given frequency and polarity. The HRPWM works together with the ePWM registers to extend edge resolution. Although many programming combinations are possible, only a few are needed and practical. These methods are described in [Section 7.4.5.16.1.8](#).

7.4.5.16.1.1 Controlling the HRPWM Capabilities

The MEP of the HRPWM is controlled by six extension registers. These HRPWM registers are concatenated with the 16-bit TBPHS, TBPRD, CMPA, CMPBM, DBREDM, and DBFEDM registers used to control PWM operation.

- TBPHSHR - Time Base Phase High Resolution Register
- CMPAHR - Counter Compare A High Resolution Register; CMPAHR is for use with the AQ output of Channel A, and is not related to CMPA
- TBPRDHR - Time Base Period High Resolution Register. (available on some devices)
- CMPBHR - Counter Compare B High Resolution Register; CMPBHR is for use with the AQ output of Channel B, and is not related to CMPB
- DBREDHR - Deadband Generator Rising Edge Delay High Resolution Register
- DBFEDHR - Deadband Generator Falling Edge Delay High Resolution Register

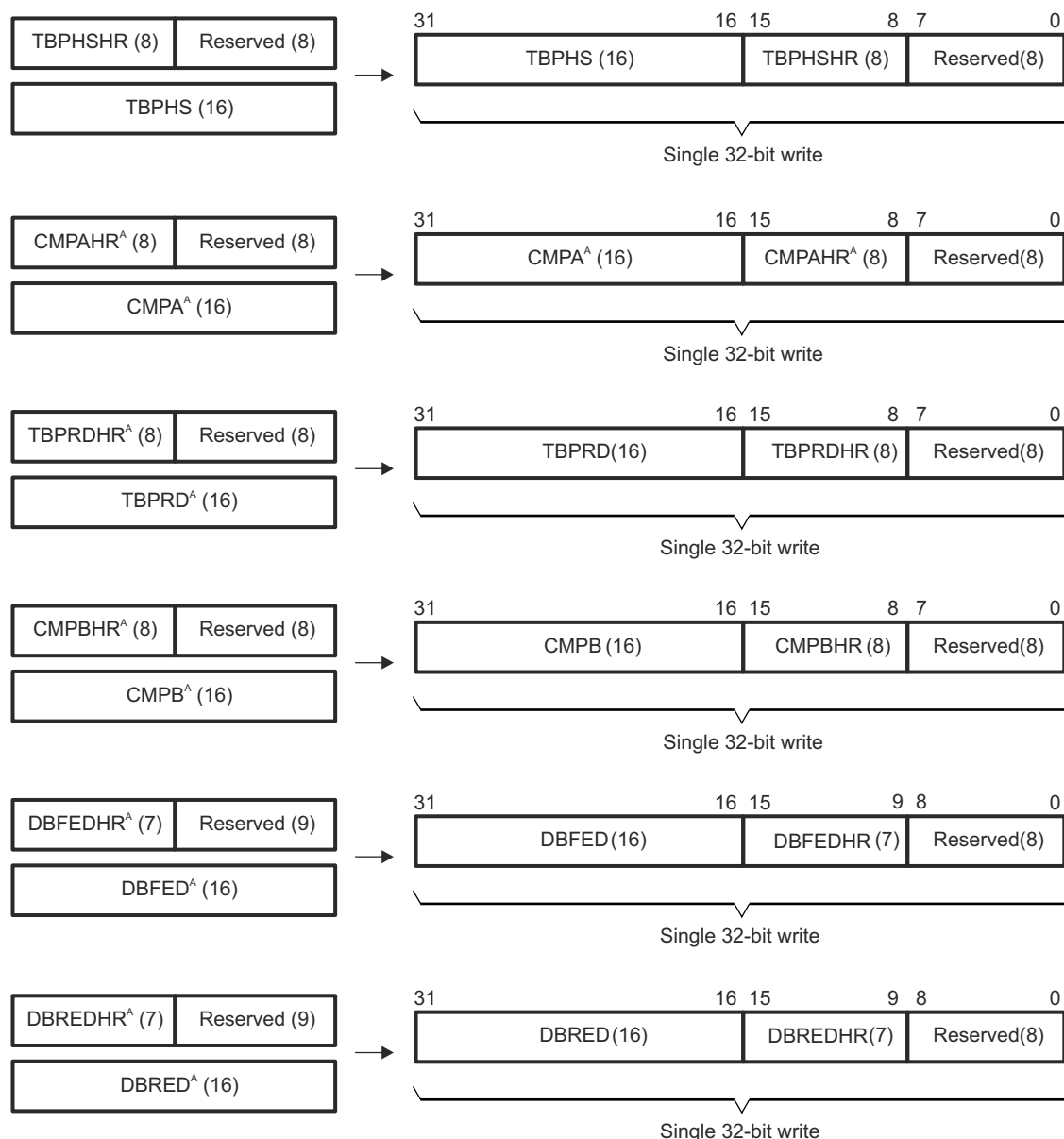

A. Dependant upon your device, these registers may be mirrored and can be written to at two different memory locations. Check the device-specific Technical Reference Manual's *ePWM* chapter for more details on how to read and write to these locations.

Figure 7-180. HRPWM Extension Registers and Memory Configuration

Note

HRPWM capabilities on Deadband Rising Edge Delay and Falling Edge Delay is applicable only during Dead Band half cycle clocking Operation. The number of MEP steps is half in size [bits 15:9] than duty and phase high resolution registers for the same reason

HRPWM capabilities are controlled using the Channel A and B PWM signal path. HRPWM support on the Dead band signal path is available by properly configuring the HRCNFG2 register. shows how the HRPWM interfaces with the 8-bit extension registers.

7.4.5.16.1.2 HRPWM Source Clock

7.4.5.16.1.3 Configuring the HRPWM

Once the ePWM has been configured to provide conventional PWM of a given frequency and polarity, the HRPWM is configured by programming the HRCNFG register in that particular ePWM module's register space. This register provides the following configuration options:

- Edge Mode** The MEP can be programmed to provide precise position control on the rising edge (RE), falling edge (FE) or both edges (BE) at the same time. FE and RE are used for power topologies requiring duty cycle control (CMPA or CMPB high-resolution control), while BE is used for topologies requiring phase shifting, for example, phase shifted full bridge (TBPHS or TBPRD high-resolution control).
- Control Mode** The MEP is programmed to be controlled either from the CMPAHR/CMPBHR register in case of duty cycle control or the TBPHSHR register (phase control). RE or FE control mode can be used with the CMPAHR or CMPBHR register. BE control mode can be used with the TBPHSHR register. When the MEP is controlled from the TBPRDHR register (period control), the duty cycle and phase can also be controlled using their respective high-resolution registers.
- Shadow Mode** This mode provides the same shadowing (double buffering) option as in regular PWM mode. This option is valid only when operating from the CMPAHR, CMPBHR, and TBPRDHR registers and can be chosen to be the same as the regular load option for the CMPA/CMPB register. If TBPHSHR is used, then this option has no effect.
- High-Resolution B Signal Control** The B signal path of an ePWM channel can generate a high-resolution output by outputting an inverted version of the high-resolution ePWMxA signal on the ePWMxB pin. A Type 2 or Type 4 HRPWM module can also enable high-resolution features on the B signal path independently of the A signal path as well.

Swap ePWMxA and ePWMxB Outputs This mode enables the swapping of the high-resolution A and B outputs. The mode selection allows either A and B Outputs Unchanged or A Output Comes Out On B and B Output Comes Out On A.

Auto-conversion Mode This mode is used in conjunction with the scale factor optimization (SFO) software only. For a type 4 HRPWM module, below is a description of the Auto-conversion Mode taking CMPAHR as an example. If auto-conversion is enabled, $CMPAHR = \text{fraction}(PWMduty * PWMperiod) \ll 8$. The scale factor optimization software calculates the MEP scale factor in the background code and automatically updates the HRMSTEP register with the calculated number of MEP steps per coarse step. The MEP Calibration Module then uses the values in the HRMSTEP and CMPAHR registers to automatically calculate the appropriate number of MEP steps represented by the fractional duty cycle and moves the high-resolution ePWM signal edge accordingly. If auto-conversion is disabled, the CMPAHR register behaves like a type 0 HRPWM module and $CMPAHR = (\text{fraction}(PWMduty * PWMperiod) * MEP \text{ Scale Factor} + 0.5) \ll 8$. All calculations need to be performed by your code in this mode, and the HRMSTEP register is ignored. Auto-conversion for high-resolution period has the same behavior as auto-conversion for high-resolution duty cycle. Auto-conversion must always be enabled for high-resolution period mode.

Note

If the HRPWM module is configured in UP-DOWN counter mode, the shadow mode for the HRPWM registers must be set to load on both ZERO AND PERIOD. New values from the user are loaded to the shadow registers only at CTR=ZERO, but the shadow mode of for the registers must be set to both ZERO AND PERIOD. The CTR=PRD event is used for specific internal logic inside the HRPWM module.

Auto-conversion Mode performs the calculation for CMPBHR, DBREDHR, and DBFEDHR. The scale factor optimization software calculates the MEP scale factor in the background code and automatically updates the HRMSTEP register with the calculated number of MEP steps per coarse step. The MEP Calibration Module then uses the values in the HRMSTEP and CMPBHR or DBREDHR/DBFEDHR register to automatically calculate the appropriate number of MEP steps represented by the fractional components and moves the high-resolution ePWM signal edge accordingly. If auto-conversion is disabled, CMPBHR behaves the same as CMPAHR. $CMPBHR = (\text{fraction}(PWMduty * PWMperiod) * MEP \text{ Scale Factor} + 0.5) \ll 8$.

7.4.5.16.1.4 Configuring Hi-Res in Deadband Rising Edge and Falling Edge Delay

Once the ePWM has been configured to provide conventional PWM of a given frequency, polarity and deadband enabled in half cycle clocking mode, the high-resolution operation on dead band RED and FED lines are enabled by programming the HRCNFG2 register in that particular ePWM module register space. This register provides the following configuration options:

- Edge Mode** The MEP can be programmed to provide precise position control on the dead band rising edge (RED), dead band falling edge (FED), or both edges (rising edge of DBRED signal and falling edge of DBFED signal) at the same time.
- Control Mode** Selects the time event that loads the shadow value in active register for DBRED and DBFED in high-resolution mode. You need to select the pulse to match the selection in the ePWM DBCTL[LOADREDMODE] and DBCTL[LOADFEDMODE] bits.

7.4.5.16.1.5 Principle of Operation

The MEP logic is capable of placing an edge in one of 255 (8 bits) discrete time steps (see device-specific data sheet for typical MEP step size). The MEP works with the TBM and CCM registers to be certain that time steps are applied and that edge placement accuracy is maintained over a wide range of PWM frequencies, system clock frequencies, and other operating conditions. Table 7-122 shows the typical range of operating frequencies supported by the HRPWM.

Table 7-122. Relationship Between MEP Steps, PWM Frequency and Resolution

System (MHz)	MEP Steps Per EPWMCLK ^{(1) (2) (3)}	PWM Minimum (Hz) ⁽⁴⁾	PWM Maximum (MHz)	Resolution at Maximum (Bits) ⁽⁵⁾
60.0	93	916	3.00	10.9
70.0	79	1068	3.50	10.6
80.0	69	1221	4.00	10.4
90.0	62	1373	4.50	10.3
100.0	56	1526	5.00	10.1

- (1) TBCLK = EPWMCLK.
 (2) Table data based on a MEP time resolution of 180 ps (this is an example value. See the device-specific data sheet for MEP limits)
 (3) MEP steps applied = $T_{EPWMCLK}/180$ ps in this example.
 (4) PWM minimum frequency is based on a maximum period value, (TBPRD = 65535). PWM mode is asymmetrical up-count.
 (5) Resolution in bits is given for the maximum PWM frequency stated.

7.4.5.16.1.5.1 Edge Positioning

Note

The following example is presented using the [CMPA:CMPAHR] register combination. The theory of operation and equations is the same if you intend to use [CMPBM:CMPBHRM] for duty cycle control.

In a typical power control loop, a digital controller issues a duty command, usually expressed in a per unit or percentage terms. Assume that for a particular operating point, the demanded duty cycle is 0.405 or 40.5% on time and the required converter PWM frequency is 1.25 MHz. In conventional PWM generation with a system clock of 100 MHz, the duty cycle choices are in the vicinity of 40.5%. As shown in Figure 7-181, a compare value of 32 counts (duty = 40%) is the closest to 40.5% that can be attained. This is equivalent to an edge position of 320 ns instead of the desired 324 ns. This data is shown in Table 7-123.

By utilizing the MEP, you can achieve an edge position much closer to the desired point of 324 ns. Table 7-123 shows that in addition to the CMPA value, 22 steps of the MEP (CMPAHR register) will position the edge at 323.96 ns, resulting in almost zero error. In this example, it is assumed that the MEP has a step resolution of 180 ps.

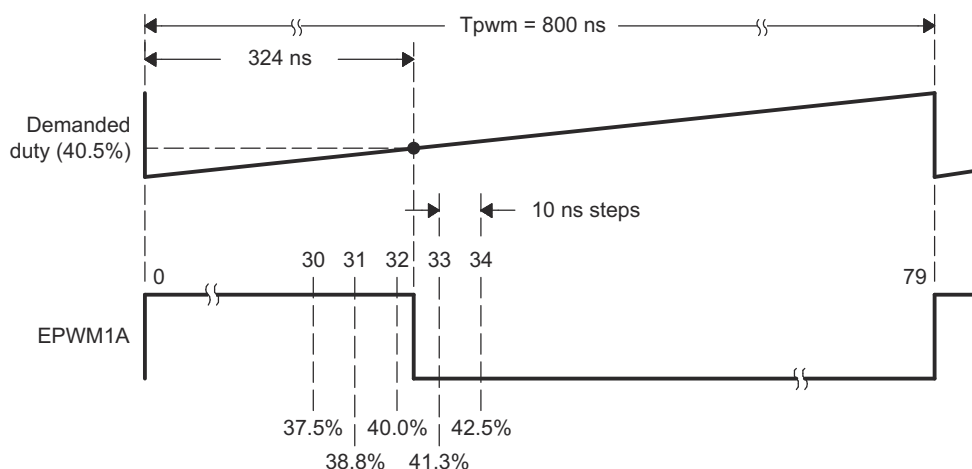

Figure 7-181. Required PWM Waveform for a Requested Duty = 40.5%

Table 7-123. CMPA vs Duty (left), and [CMPA:CMPAHR] vs Duty (right)

CMPA (count) ^{(1) (2) (3)}	Duty (%)	High Time (ns)	CMPA (count)	CMPAHR (count)	Duty (%)	High Time (ns)
28	35.0	280	32	18	40.405	323.24
29	36.3	290	32	19	40.428	323.42
30	37.5	300	32	20	40.450	323.60
31	38.8	310	32	21	40.473	323.78
32	40.0	320	32	22	40.495	323.96
33	41.3	330	32	23	40.518	324.14
34	42.5	340	32	24	40.540	324.32
			32	25	40.563	324.50
Required			32	26	40.585	324.68
32.40	40.5	324	32	27	40.608	324.86

- (1) Assumed MEP step size for the above example = 180 ps. See the device-specific data manual for typical and maximum MEP values.
- (2) TBCLK = 100 MHz, 10 ns
- (3) For a PWM Period register value of 80 counts, PWM Period = 80 x 10 ns = 800 ns, PWM frequency = 1/800 ns = 1.25 MHz

7.4.5.16.1.5.2 Scaling Considerations

The mechanics of how to position an edge precisely in time has been demonstrated using the resources of the standard CMPA and MEP (CMPAHR) registers. In a practical application, however, it is necessary to seamlessly provide the CPU a mapping function from a per-unit (fractional) duty cycle to a final integer (non-fractional) representation that is written to the [CMPA:CMPAHR] register combination.

To do this, first examine the scaling or mapping steps involved. It is common in control software to express duty cycle in a per-unit or percentage basis. This has the advantage of performing all needed math calculations without concern for the final absolute duty cycle, expressed in clock counts or high time in ns. Furthermore, it makes the code more transportable across multiple converter types running different PWM frequencies.

To implement the mapping scheme, a two-step scaling procedure is required.

Assumptions for this example:

TBCLK	=	10 ns (100 MHz)
PWM frequency	=	1.25 MHz (1/800 ns)
Required PWM duty cycle, PWMDuty	=	0.405 (40.5%)
PWM period in terms of coarse steps, PWMPeriod (800 ns/10 ns)	=	80
Number of MEP steps per coarse step at 180 ps (10 n/180 ps), MEP_ScaleFactor	=	55
Value to keep CMPAHR within the range of 1-255 and fractional rounding constant (default value)	=	0.5 (0080h in Q8 format)

Step 1: Percentage Integer Duty value conversion for CMPA register

CMPA register value	=	$\text{int}(\text{PWMDuty} * \text{PWMPeriod})$; int means integer part
	=	$\text{int}(0.405 * 80)$
	=	$\text{int}(32.4)$
CMPA register value	=	32 (20h)

Step 2: Fractional value conversion for CMPAHR register

CMPAHR	=	$(\text{frac}(\text{PWMDuty} * \text{PWMPeriod}) * \text{MEP_ScaleFactor} + 0.5) \ll 8$; frac means fractional part
	=	$(\text{frac}(32.4) * 55 + 0.5) \ll 8$; Shifting is to move the value to the high byte of CMPAHR.
	=	$(0.4 * 55 + 0.5) \ll 8$
	=	$(22 + 0.5) \ll 8$
	=	$22.5 * 256$; Shifting left by 8 is the same as multiplying by 256.
	=	5760 (1680h)
CMPAHR	=	1680h CMPAHR value = 1600h (lower 8 bits will be ignored by hardware).

Note

If the AUTOCONV bit (HRCNFG.6) is set and the MEP_ScaleFactor is in the HRMSTEP register, then CMPAHR / CMPBHR register value = $\text{frac}(\text{PWMDuty} * \text{PWMperiod} << 8)$. The rest of the conversion calculations are performed automatically in hardware, and the correct MEP-scaled signal edge appears on the ePWM channel output. If AUTOCONV is not set, the above calculations must be performed by software.

The MEP scale factor (MEP_ScaleFactor) varies with the system clock and DSP operating conditions. TI provides an MEP scale factor optimizing (SFO) software C function, which uses the built in diagnostics in each HRPWM and returns the best scale factor for a given operating point.

The scale factor varies slowly over a limited range so the optimizing C function can be run very slowly in a background loop.

The CMPA, CMPB, CMPAHR and CMPBHR registers are configured in memory so that the 32-bit data capability of the C28x CPU can write this as a single concatenated value, that is, [CMPA:CMPAHR], [CMPB:CMPBHR], and so on.

The mapping scheme has been implemented in both C and assembly, as shown in [Section 7.4.5.16.1.8](#). The actual implementation takes advantage of the 32-bit CPU architecture of the C28x, and is somewhat different from the steps shown in [Section 7.4.5.16.1.5.2](#).

For time-critical control loops where every cycle counts, the assembly version is recommended. This is a cycle optimized function (11 EPWMCLK cycles) that takes a Q15 duty value as input and writes a single [CMPA:CMPAHR] value.

7.4.5.16.1.5.3 Duty Cycle Range Limitation

In high resolution mode, the MEP is not active for 100% of the PWM period. It becomes operational:

- Three EPWMCLK cycles after the period starts when high-resolution period (TBPRDHR) control is not enabled.
- When high resolution period (TBPRDHR) control is enabled via the HRPCTL register:
 - In up-count mode: three EPWMCLK cycles after the period starts until three EPWMCLK cycles before the period ends.
 - In up-down count mode: when counting up, three cycles after CTR = 0 until three cycles before CTR = PRD, and when counting down, three cycles after CTR = PRD until three cycles before CTR = 0.
- When using DBREDHR or DBFEDHR, DBRED and/or DBFED (the register corresponding to the edge with hi-resolution displacement) must be greater than or equal to 7.

Duty cycle range limitations are illustrated in [Figure 7-182](#) to [Figure 7-185](#). This limitation imposes a duty cycle limit on the MEP. For example, precision edge control is not available all the way down to 0% duty cycle. When high-resolution period control is disabled, regular PWM duty control is fully operational down to 0% duty cycle despite the unavailability of HRPWM features in the first three cycles. In most applications this should not be an issue as the controller regulation point is usually not designed to be close to 0% duty cycle. To better understand the useable duty cycle range, see [Table 7-124](#). When high-resolution period control is enabled (HRPCTL[HRPE]=1), the duty cycle must not fall within the restricted range. Otherwise, there may be undefined behavior on the ePWMxA output.

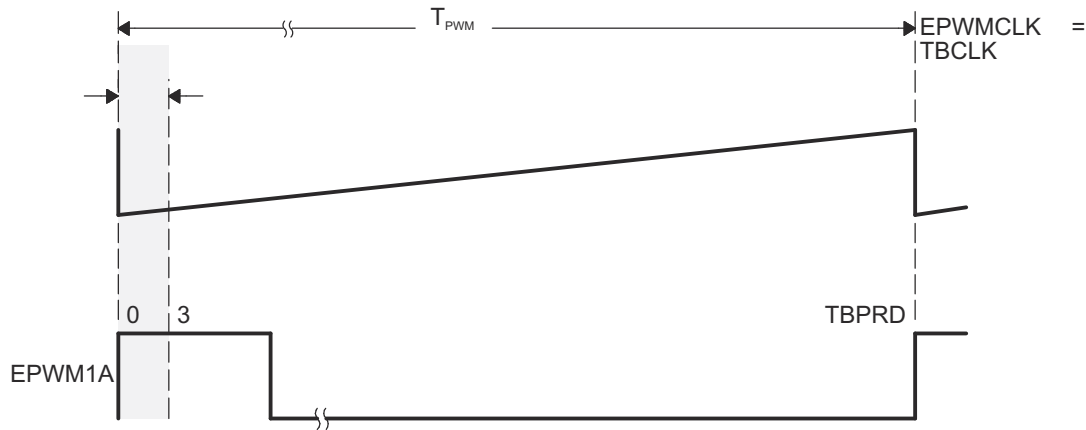

Figure 7-182. Low % Duty Cycle Range Limitation Example (HRPCTL[HRPE] = 0)

Table 7-124. Duty Cycle Range Limitation for Three EPWMCLK/TBCLK Cycles

PWM Frequency ⁽¹⁾ (kHz)	3 Cycles Minimum Duty	3 Cycles Maximum Duty ⁽²⁾
200	0.6%	99.4%
400	1.2%	98.8%
600	1.8%	98.2%
800	2.4%	97.6%
1000	3%	97%
1200	3.6%	96.4%
1400	4.2%	95.8%
1600	4.8%	95.2%
1800	5.4%	94.6%
2000	6%	94%

(1) EPWMCLK = TBCLK = 100 MHz

(2) This limitation applies only if high-resolution period (TBPRDHR) control is enabled.

If the application demands HRPWM operation below the minimum duty cycle limitation, then the HRPWM can be configured to operate in count-down mode with the rising edge position (REP) controlled by the MEP when high-resolution period is disabled (HRPCTL[HRPE] = 0). This is illustrated in Figure 7-183. In this configuration, the minimum duty cycle limitation is no longer an issue. However, there will be a maximum duty limitation with same percent numbers as given in Table 7-124.

CAUTION

If the application has enabled high-resolution period control (HRPCTL[HRPE]=1), the duty cycle must not fall within the restricted range. Otherwise, there will be undefined behavior on the ePWM output.

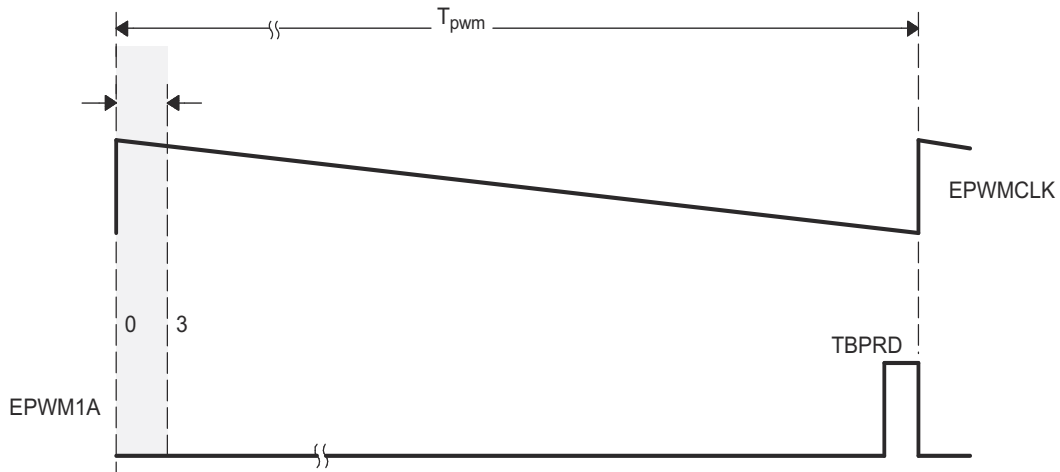

Figure 7-183. High % Duty Cycle Range Limitation Example (HRPCTL[HRPE] = 0)

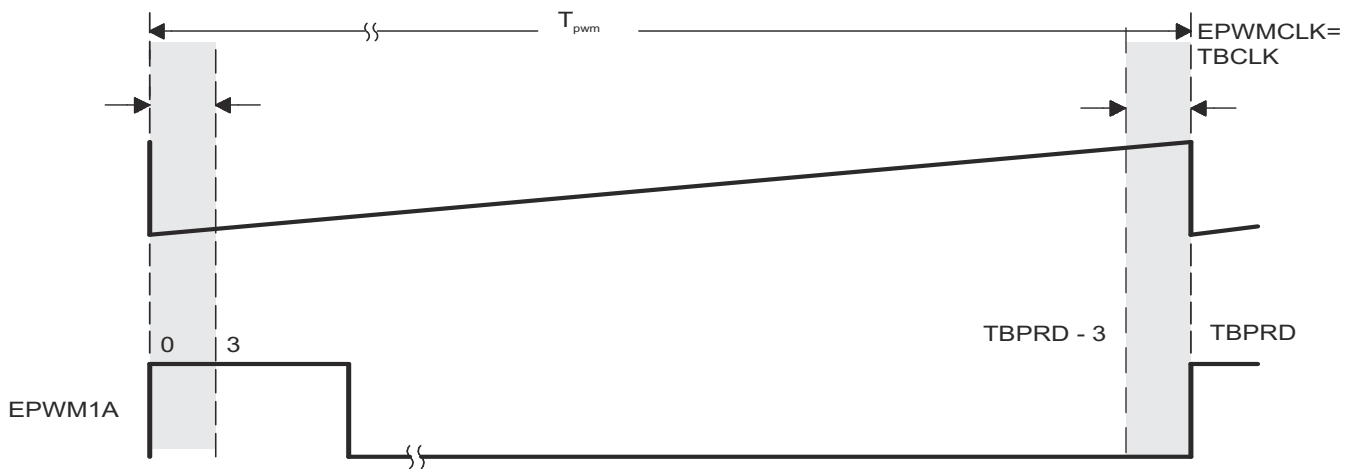

Figure 7-184. Up-Count Duty Cycle Range Limitation Example (HRPCTL[HRPE]=1)

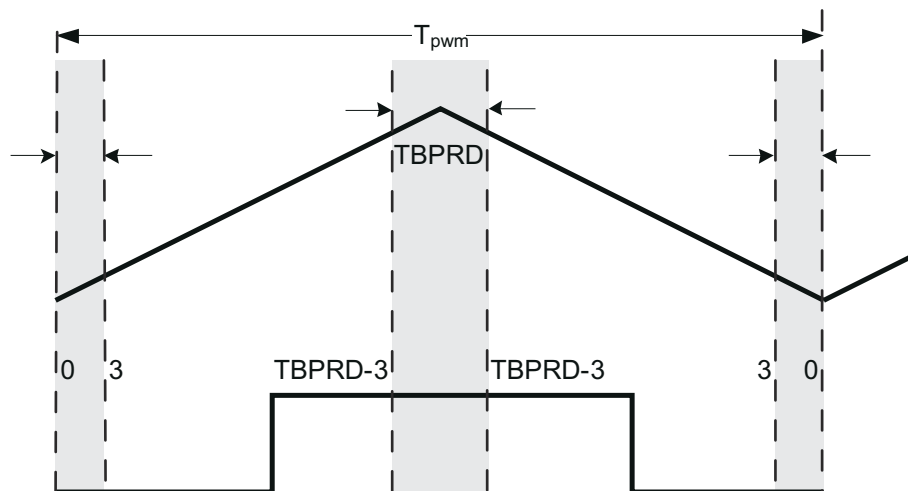

Figure 7-185. Up-Down Count Duty Cycle Range Limitation Example (HRPCTL[HRPE]=1)

7.4.5.16.1.5.4 High Resolution Period

High resolution period control using the MEP logic is supported on devices with a Type 1 ePWM module or greater.

Note

When high-resolution period control is enabled, on ePWMxA only, and not ePWMxB output and vice versa, the non hi-res output will have +/- 1 TBCLK cycle jitter in up-count mode and +/- 2 TBCLK cycle jitter in up-down count mode.

The scaling procedure described for duty cycle in [Section 7.4.5.16.1.5.2](#) applies for high-resolution period as well:

Assumptions for this example:

TBCLK	= 10 ns (100 MHz)
Required PWM frequency	= 175 kHz (period of 571.428)
Number of MEP steps per coarse step at 180 ps (MEP_ScaleFactor)	= 55 (10 ns / 180 ps)
Value to keep TBPRDHR within range of 1-255 and fractional rounding constant (default value)	= 0.5 (0080h in Q8 format)

Problem:

In up-count mode:

If TBPRD = 571, then PWM frequency = 174.82 kHz (period = $(571+1) * T_{TBCLK}$).

If TBPRD = 570, then PWM frequency = 175.13 kHz (period = $(570+1) * T_{TBCLK}$).

In up-down count mode:

If TBPRD = 286, then PWM frequency = 174.82 kHz (period = $(286*2) * T_{TBCLK}$).

If TBPRD = 285, then PWM frequency = 175.44 kHz (period = $(285*2) * T_{TBCLK}$).

Solution:

With 55 MEP steps per coarse step at 180 ps each:

Step 1: Percentage Integer Period value conversion for TBPRD register

Integer period value	= $571 * T_{TBCLK}$ = $\text{int}(571.428) * T_{TBCLK}$ = $\text{int}(\text{PWMperiod}) * T_{TBCLK}$
----------------------	--

In up-count mode:

TBPRD	= 570 (TBPRD = period value - 1) = 023Ah
-------	---

In up-down count mode:

TBPRD	= 285 (TBPRD = period value / 2) = 011Dh
-------	---

Step 2: Fractional value conversion for TBPRDHR register

TBPRDHR register value	= $(\text{frac}(\text{PWMperiod}) * \text{MEP_ScaleFactor} + 0.5)$
If auto-conversion enabled and HRMSTEP = MEP_ScaleFactor value (55):	= $\text{frac}(\text{PWMperiod}) \ll 8$ (Shifting is to move the value to the high byte of TBPRDHR)
TBPRDHR register value	= $\text{frac}(571.428) \ll 8$ = $0.428 * 256$

The autoconversion will then automatically perform the calculation such that TBPRDHR MEP delay is scaled by hardware to:

$$=6D00h$$

$$=((TBPRDHR(15:0) \gg 8) \times HRMSTEP + 80h) \ll 8$$

$$= (006Dh \times 55 + 80h) \gg 8$$

$$=(17EBh) \gg 8$$

Period MEP delay =0017h MEP Steps

7.4.5.16.1.5.4.1 High-Resolution Period Configuration

To use High Resolution Period, the ePWMx module must be initialized in the exact order presented.

The steps below use CMPA with shadow registers and the corresponding HRCNFG bits for hi-resolution operation on EPWMxA. For hi-resolution operation on EPWMxB, make the appropriate substitutions with the B channel fields.

1. Enable ePWMx clock
2. Enable HRPWM clock
3. Disable TBCLKSYNC
4. Configure ePWMx registers - AQ, TBPRD, CC, and so on.
 - ePWMx may only be configured for up-count or up-down count modes. High-resolution period is not compatible with down-count mode.
 - TBPRD and CC registers must be configured for shadow loads.
 - CMPCTL[LOADAMODE]
 - In up-count mode: CMPCTL[LOADAMODE] = 1 (load on CTR = PRD)
 - In up-down count mode: CMPCTL[LOADAMODE] = 2 (load on CTR=0 or CTR=PRD)
5. Configure the HRCNFG register such that:
 - HRCNFG[HRLOAD] = 2 (load on either CTR = 0 or CTR = PRD)
 - HRCNFG[AUTOCONV] = 1 (Enable auto-conversion)
 - HRCNFG[EDGMODE] = 3 (MEP control on both edges)
6. For TBPHS:TBPHSHR synchronization with high-resolution period, set both HRPCTL[TBPSHRLOADE] = 1 and TBCTL[PHSEN] = 1. In up-down count mode these bits must be set to 1 regardless of the contents of TBPHSHR.
7. Enable high-resolution period control (HRPCTL[HRPE] = 1)
8. Enable TBCLKSYNC
9. TBCTL[SWFSYNC] = 1
10. HRMSTEP must contain an accurate MEP scale factor (# of MEP steps per EPWMCLK coarse step) because auto-conversion is enabled. The MEP scale factor can be acquired via the SFO() function described in [Section 7.4.5.16.2](#).
11. To control high-resolution period, write to the TBPRDHR(M) registers.

Note

When high-resolution period mode is enabled, an EPWMxSYNC pulse will introduce +/- 1 - 2 cycle jitter to the PWM (+/- 1 cycle in up-count mode and +/- 2 cycle in up-down count mode). For this reason, . Otherwise, the jitter will occur on every PWM cycle with the synchronization pulse.

When , a software synchronization pulse should be issued only once during high-resolution period initialization. If a software sync pulse is applied while the PWM is running, the jitter will appear on the PWM output at the time of the sync pulse.

7.4.5.16.1.6 Deadband High Resolution Operation

Note

In up-count mode, the deadband module is **NOT** available when any high resolution mode is enabled.

Assumptions for this example:

System clock	= 10 ns (100 MHz)
Deadband Enabled in half cycle mode, TBCLK = EPWMCLK	
Required PWM frequency	1.33 MHz (1 / 750 ns)
Required PWM duty cycle	0.5 (50%)
Required Dead band Rising Edge Delay	5% over duty
Required Dead band Rising Edge Delay in ns	(0.05 * 375 ns) = 18.75 ns

Note

Just like the duty cycle restrictions when using HRPWM, the DBRED and DBFED values must be greater than 3 to use high resolution deadband.

Deadband Delay Values as a Function of DBFED and DBRED:

When half-cycle clocking is enabled, the formula to calculate the falling-edge-delay and rising-edge-delay becomes:

$$FED = DBFED * TBCLK / 2$$

$$RED = DBRED * TBCLK / 2$$

DBRED and DBFED Calculated Values:

Required Dead band Rising Edge Delay in ns = 18.75 ns

$$DBRED = RED / (TBCLK / 2)$$

$$DBRED = 18.75 \text{ ns} / 5 \text{ ns}$$

$$DBRED \text{ Required} = 3.75 \text{ ns}$$

With 55 MEP steps per coarse step at 180 ps each:

Step 1: Integer Dead band value conversion for DBREDM register

Integer DBRED value	= int (RED / (TBCLK / 2))
	= int (3.75)
DBRED	= 3

Step 2: Fractional value conversion for Dead band high resolution register DBREDHR

DBREDHR register value	$= (\text{frac}(\text{DBRED Required}) * \text{MEP_ScaleFactor} + 0.5) \ll 8$ (Shifting is to move the value to the high byte of DBREDHR)
	$= (\text{frac}(3.75) * 55 + 0.5) \ll 8$
	$= (0.75 * 55 + 0.5) \ll 8$
	$= (41.75) * 256$ Shifting left by 8 is the same as multiplying by 256.
DBREDHR value	$= 29C0h$ MEP Steps
	Hardware will ignore lower 9 bits in the above calculated DBREDHR value

Note

If the AUTOCONV bit (HRCNFG.6) is set and the MEP_ScaleFactor is in the HRMSTEP register, then DBREDHR:DBRED = $\text{frac}(\text{required DB value}) \ll 8$. The rest of the conversion calculations are performed automatically in hardware, and the correct MEP-scaled signal edge appears on the ePWM channel output. If AUTOCONV is not set, the above calculations must be performed by software.

7.4.5.16.1.7 Scale Factor Optimizing Software (SFO)

The micro edge positioner (MEP) logic is capable of placing an edge in one of 255 discrete time steps. As previously mentioned, the size of these steps is on the order of 150 ps (see device-specific data sheet for typical MEP step size on your device). The MEP step size varies based on worst-case process parameters, operating temperature, and voltage. MEP step size increases with decreasing voltage and increasing temperature and decreases with increasing voltage and decreasing temperature. Applications that use the HRPWM feature should use the TI-supplied MEP scale factor optimization (SFO) software function. The SFO function helps to dynamically determine the number of MEP steps per EPWMCLK period while the HRPWM is in operation.

To utilize the MEP capabilities effectively, the correct value for the MEP scaling factor needs to be known by the software. To accomplish this, the HRPWM module has built in self-check and diagnostic capabilities that can be used to determine the optimum MEP scale factor value for any operating condition. TI provides a C-callable library containing one SFO function that utilizes this hardware and determines the optimum MEP scale factor. As such, MEP control and diagnostics registers are reserved for TI use.

A detailed description of the SFO library - SFO_TI_Build_V8.lib software can be found in [Section 7.4.5.16.2](#).

7.4.5.16.1.8 HRPWM Examples Using Optimized Assembly Code

The best way to understand how to use the HRPWM capabilities is through two real examples:

1. Simple buck converter using asymmetrical PWM (count-up) with active high polarity.
2. DAC function using simple R+C reconstruction filter.

The following examples all have initialization and configuration code written in C. To make these easier to understand, the #defines shown below are used.

[Example 7-2](#) assumes MEP step size of 150 ps and does not use the SFO library.

Example 7-2. #Defines for HRPWM Header Files

```
// HRPWM (High Resolution PWM) //
=====
// HRCNFG
#define HR_Disable 0x0
#define HR_REP 0x1 // Rising Edge position
#define HR_FEP 0x2 // Falling Edge position
#define HR_BEP 0x3 // Both Edge position #define HR_CMP 0x0 // CMPAHR controlled
#define HR_PHS 0x1 // TBPHSHR controlled #define HR_CTR_ZERO 0x0 // CTR = Zero event
#define HR_CTR_PRD 0x1 // CTR = Period event
#define HR_CTR_ZERO_PRD 0x2 // CTR = ZERO or Period event
#define HR_NORM_B 0x0 // Normal ePWMxB output
#define HR_INVERT_B 0x1 // ePWMxB is inverted ePWMxA output
```

7.4.5.16.1.8.1 Implementing a Simple Buck Converter

In this example, the PWM requirements are:

- PWM frequency = 1 MHz (that is, TBPRD = 100)
- PWM mode = asymmetrical, up-count
- Resolution = 12.7 bits (with a MEP step size of 150 ps)

Figure 7-186 and Figure 7-187 show the required PWM waveform. As explained previously, configuration for the ePWM1 module is almost identical to the normal case except that the appropriate MEP options need to be enabled/selected.

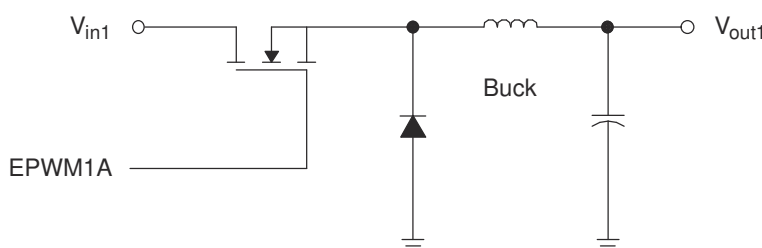

Figure 7-186. Simple Buck Controlled Converter Using a Single PWM

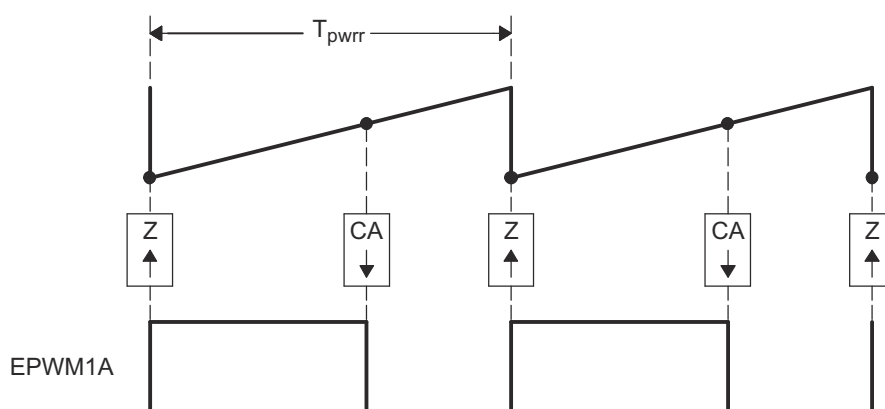

Figure 7-187. PWM Waveform Generated for Simple Buck Controlled Converter

The example code shown consists of two main parts:

- Initialization code (executed once)
- Run time code (typically executed within an ISR)

Example 7-3 shows the Initialization code. The first part is configured for conventional PWM. The second part sets up the HRPWM resources.

This example assumes MEP step size of 150 ps and does not use the SFO library.

Example 7-4 shows an assembly example of run-time code for the HRPWM buck converter.

Example 7-3. HRPWM Buck Converter Initialization Code

```

void HrBuckDrvCnf(void)
{
// Config for conventional PWM first
EPwm1Regs.TBCTL.bit.PRDL = TB_IMMEDIATE;           // set Immediate load
EPwm1Regs.TBPRD = 100;                             // Period set for 1000 kHz PWM
hrbuck_period = 200;                                // Used for Q15 to Q0 scaling
EPwm1Regs.TBCTL.bit.CTRMODE = TB_COUNT_UP;
EPwm1Regs.TBCTL.bit.PHSEN = TB_DISABLE;           // EPWM1 is the Sync Source

EPwm1Regs.TBCTL.bit.HSPCLKDIV = TB_DIV1;
EPwm1Regs.TBCTL.bit.CLKDIV = TB_DIV1;
// Note: ChB is initialized here only for comparison purposes, it is not required

EPwm1Regs.CMPCTL.bit.LOADAMODE = CC_CTR_ZERO;
EPwm1Regs.CMPCTL.bit.SHDWAMODE = CC_SHADOW;
EPwm1Regs.CMPCTL.bit.LOADBMODE = CC_CTR_ZERO;     // optional
EPwm1Regs.CMPCTL.bit.SHDWBMODE = CC_SHADOW;     // optional
EPwm1Regs.AQCTLA.bit.ZRO = AQ_SET;
EPwm1Regs.AQCTLA.bit.CAU = AQ_CLEAR;
EPwm1Regs.AQCTLB.bit.ZRO = AQ_SET;               // optional
EPwm1Regs.AQCTLB.bit.CBU = AQ_CLEAR;            // optional
// Now configure the HRPWM resources
EALLOW;                                           // Note these registers are protected
                                                    // and act only on ChA
EPwm1Regs.HRCNFG.all = 0x0;                       // clear all bits first
EPwm1Regs.HRCNFG.bit.EDGMODE = HR_FEP;           // Control Falling Edge Position
EPwm1Regs.HRCNFG.bit.CTLMODE = HR_CMP;           // CMPAHR controls the MEP
EPwm1Regs.HRCNFG.bit.HRLOAD = HR_CTR_ZERO;       // Shadow load on CTR=Zero
EDIS;
MEP_ScaleFactor = 66*256;                         // Start with typical Scale Factor
                                                    // value for 100 MHz
                                                    // Note: Use SFO functions to update
                                                    // MEP_ScaleFactor dynamically
}

```

Example 7-4. HRPWM Buck Converter Run-Time Code

```

EPWM1_BASE .set 0x6800
CMPAHR1 .set EPWM1_BASE+0x8
;=====
HRBUCK_DRV; (can execute within an ISR or loop)
;=====
    MOVW DP, # HRBUCK_In
    MOVL XAR2,@_HRBUCK_In           ; Pointer to Input Q15 Duty (XAR2)
    MOVL XAR3,#CMPAHR1             ; Pointer to HRPWM CMPA reg (XAR3)

; Output for EPWM1A (HRPWM)
    MOV T,*XAR2 ; T <= Duty
    MPYU ACC,T,@_hrbuck_period     ; Q15 to Q0 scaling based on Period
    MOV T,@_MEP_ScaleFactor        ; MEP scale factor (from optimizer s/w)
    MPYU P,T,@AL
    MOVH @AL,P                     ; P <= T * AL, Optimizer scaling
    ADD ACC,#0x080                 ; AL <= P, move result back to ACC
    MOVL *XAR3,ACC                 ; MEP range and rounding adjustment
    CMPA: CMPAHR(31:8) <= ACC

; Output for EPWM1B (Regular Res) Optional - for comparison purpose only
    MOV *+XAR3[2],AH               ; Store ACCH to regular CMPB

```

7.4.5.16.1.8.2 Implementing a DAC Function Using an R+C Reconstruction Filter

In this example, the PWM requirements are:

- PWM frequency = 400 kHz (that is, TBPRD = 250)
- PWM mode = Asymmetrical, Up-count
- Resolution = 14 bits (MEP step size = 150 ps)

Figure 7-188 and Figure 7-189 show the DAC function and the required PWM waveform. As explained previously, configuration for the ePWM1 module is almost identical to the normal case except that the appropriate MEP options need to be enabled/selected.

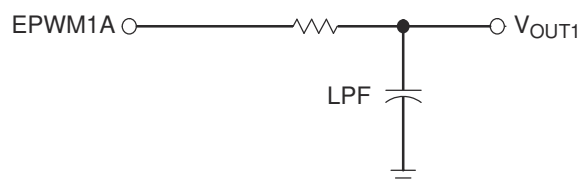

Figure 7-188. Simple Reconstruction Filter for a PWM-based DAC

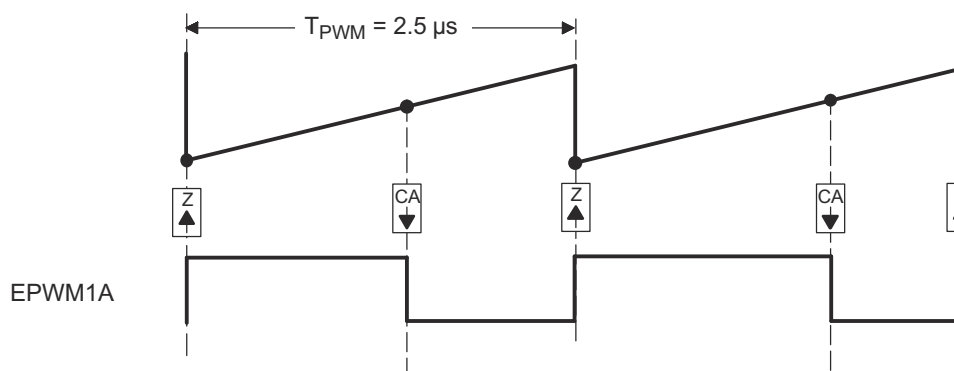

Figure 7-189. PWM Waveform Generated for the PWM DAC Function

The example code shown consists of two main parts:

- Initialization code (executed once)
- Run time code (typically executed within an ISR)

This example assumes a typical MEP_SP and does not use the SFO library.

Example 7-5 shows the Initialization code. The first part is configured for conventional PWM. The second part sets up the HRPWM resources.

Example 7-6 shows an assembly example of run-time code that can execute in a high-speed ISR loop.

Example 7-5. PWM DAC Function Initialization Code

```

void HrPwmDacDrvCnf(void)
{
// Config for conventional PWM first
EPwm1Regs.TBCTL.bit.PRDL = TB_IMMEDIATE;           // Set Immediate load
EPwm1Regs.TBPRD = 250;                             // Period set for 400 kHz PWM
hrDAC_period = 250;                                 // Used for Q15 to Q0 scaling
EPwm1Regs.TBCTL.bit.CTRMODE = TB_COUNT_UP;
EPwm1Regs.TBCTL.bit.PHSEN = TB_DISABLE;           // EPWM1 is the Sync Source

EPwm1Regs.TBCTL.bit.HSPCLKDIV = TB_DIV1;
EPwm1Regs.TBCTL.bit.CLKDIV = TB_DIV1;
// Note: ChB is initialized here only for comparison purposes, it is not required

EPwm1Regs.CMPCTL.bit.LOADAMODE = CC_CTR_ZERO;
EPwm1Regs.CMPCTL.bit.SHDWAMODE = CC_SHADOW;
EPwm1Regs.CMPCTL.bit.LOADBMODE = CC_CTR_ZERO; // optional
EPwm1Regs.CMPCTL.bit.SHDWBMODE = CC_SHADOW; // optional

EPwm1Regs.AQCTLA.bit.ZRO = AQ_SET;
EPwm1Regs.AQCTLA.bit.CAU = AQ_CLEAR;
EPwm1Regs.AQCTLB.bit.ZRO = AQ_SET; // optional
EPwm1Regs.AQCTLB.bit.CBU = AQ_CLEAR; // optional
// Now configure the HRPWM resources
EALLOW; // Note these registers are protected
// and act only on ChA.
EPwm1Regs.HRCNFG.all = 0x0; // Clear all bits first
EPwm1Regs.HRCNFG.bit.EDGMODE = HR_FEP; // Control falling edge position
EPwm1Regs.HRCNFG.bit.CTLMODE = HR_CMP; // CMPAHR controls the MEP.
EPwm1Regs.HRCNFG.bit.HRLOAD = HR_CTR_ZERO; // Shadow load on CTR=Zero.
EDIS;
MEP_ScaleFactor = 66*256; // Start with typical Scale Factor
// value for 100 MHz.
// Use SFO functions to update MEP_ScaleFactor
// dynamically.
}

```

Example 7-6. PWM DAC Function Run-Time Code

```

EPWM1_BASE .set 0x6800
CMPAHR1 .set EPWM1_BASE+0x8
;=====
HRPWM_DAC_DRV; (can execute within an ISR or loop)
;=====
    MOVW DP, #HRDAC_In
    MOVL XAR2,@HRDAC_In           ; Pointer to input Q15 duty (XAR2)
    MOVL XAR3,#CMPAHR1           ; Pointer to HRPWM CMPA reg (XAR3)

; Output for EPWM1A (HRPWM)
    MOV T,*XAR2                   ; T <= duty
    MPY ACC,T,@hrDAC_period       ; Q15 to Q0 scaling based on period
    ADD ACC,@hrDAC_period<<15    ; Offset for bipolar operation
    MOV T,@MEP_ScaleFactor        ; MEP scale factor (from optimizer s/w)
    MPYU P,T,@AL                  ; P <= T * AL, optimizer scaling
    MOVH @AL,P                    ; AL <= P, move result back to ACC
    ADD ACC,#0x080                ; MEP range and rounding adjustment
    MOVL *XAR3,ACC                ; CMPA:CMPAHR(31:8) <= ACC

; Output for EPWM1B (Regular Res) Optional - for comparison purpose only
    MOV **XAR3[2],AH              ; Store ACCH to regular CMPB

```

7.4.5.16.2 SFO Library Software - SFO_TI_Build_V8.lib

Table 7-125 lists several features of the SFO_TI_Build_V8.lib library.

Table 7-125. SFO Library Features

	SFO_TI_Build_V8.lib	Unit
Completion-checking?	Yes	Function return value
Typical cycles required for SFO() to update MEP_ScaleFactor if called repetitively without interrupts	130,000	EPWMCLK cycles

7.4.5.16.2.1 Scale Factor Optimizer Function - int SFO()

This routine drives the micro-edge positioner (MEP) calibration module to run SFO diagnostics and determine the appropriate MEP scale factor (number of MEP steps per coarse EPWMCLK step) for a device at any given time.

If EPWMCLK = TBCLK = 100 MHz and assuming the MEP step size is 150 ps, the typical scale factor value at 100 MHz = 66 MEP steps per TBCLK unit (10 ns)

The function returns a MEP scale factor value:

MEP_ScaleFactor = Number of MEP steps per EPWMCLK.

Constraints when using this function:

- SFO() can be used with a minimum EPWMCLK = TBCLK = 50 MHz. MEP diagnostics logic uses EPWMCLK and not TBCLK, so the EPWMCLK restriction is an important constraint. Below 50 MHz, with device process variation, the MEP step size may decrease under cold temperature and high core voltage conditions to such a point, that 255 MEP steps will not span an entire EPWMCLK cycle.
- At any time, SFO() can be called to run SFO diagnostics on the MEP calibration module

Usage:

- SFO() can be called at any time in the background while the ePWM channels are running in HRPWM mode. The scale factor result obtained can be applied to all ePWM channels running in HRPWM mode because the function makes use of the diagnostics logic in the MEP calibration module (which runs independently of ePWM channels).
- This routine returns a 1 when calibration is finished and a new scale factor has been calculated, or a 0 if calibration is still running. The routine returns a 2 if there is an error, and the MEP_ScaleFactor is greater than the maximum 255 fine steps per coarse EPWMCLK cycle. In this case, the HRMSTEP register will maintain the last MEP scale factor value less than 256 for auto conversion.
- All ePWM modules operating in HRPWM incur only a 3-EPWMCLK cycle minimum duty cycle limitation when high-resolution period control is not used. If high-resolution period control is enabled, there is an additional duty cycle limitation 3-EPWMCLK cycles before the end of the PWM period (see Section 7.4.5.16.1.5.3).
- The SFO() function also updates the HRMSTEP register with the scale factor result. If the HRCNFG[AUTOCONV] bit is set, the application software is responsible only for setting CMPAHR = fraction(PWMduty*PWMperiod) << 8 or CMPBHR = fraction(PWMduty*PWMperiod) << 8 or TBPRDHR = fraction(PWMperiod) while running SFO() in the background. The MEP Calibration Module will then use the values in the HRMSTEP and CMPAHR/CMPBHR/TBPRDHR register to automatically calculate the appropriate number of MEP steps represented by the fractional duty cycle or period and move the high-resolution ePWM signal edge accordingly.
- If the HRCNFG[AUTOCONV] bit is clear, the HRMSTEP register is ignored. The application software will need to perform the necessary calculations manually so that:
 - $CMPAHR = (\text{fraction}(\text{PWMduty} * \text{PWMperiod}) * \text{MEP Scale Factor}) \ll 8 + 0x080$.
 - Similar behavior applies for TBPHSHR, CMPBHR, DBREDHR, DBFEDHR. Auto-conversion must be enabled when using TBPRDHR.

The following snippet shows how to use the HRPWM DUTY using driverlib functions.

```
float32_t dutyFine = 85.62;
float32_t count = (dutyFine * (float32_t)(EPWM_TIMER_TBPRD << 8))/100;
uint32_t compCount = (count);
HRPWM_setCounterCompareValue(EPWM1_BASE, HRPWM_COUNTER_COMPARE_A, compCount);
HRPWM_setCounterCompareValue(EPWM1_BASE, HRPWM_COUNTER_COMPARE_B, compCount);
```

The routine can be run as a background task in a slow loop requiring negligible CPU cycles. The repetition rate at which an SFO function needs to be executed depends on the application's operating environment. As with all digital CMOS devices, temperature and supply voltage variations have an effect on MEP operation. However, in most applications these parameters vary slowly and therefore it is often sufficient to execute the SFO function once every 5 to 10 seconds. If more rapid variations are expected, then execution may have to be performed more frequently to match the application. Note, there is no high limit restriction on the SFO function repetition rate, hence it can execute as quickly as the background loop is capable.

While using the HRPWM feature, HRPWM logic will not be active for the first three EPWMCLK cycles of the PWM period (and the last three EPWMCLK cycles of the PWM period if TBPRDHR is used). While running the application in this configuration, if high-resolution period control is disabled (HRPCTL[HRPE=0]) and the CMPA/CMPB register value is less than three cycles, then its CMPAHR/CMPBHR register must be cleared to zero. If high-resolution period control is enabled (HRPCTL[HRPE=1]), the CMPA register value must not fall below three or above TBPRD-3. This would avoid any unexpected transitions on the PWM signal.

7.4.5.16.2.2 Software Usage

The software library function SFO(), calculates the MEP scale factor for the HRPWM-supported ePWM modules. The scale factor is an integer value in the range 1-255, and represents the number of micro step edge positions available for a system clock period. The scale factor value is returned in an integer variable called MEP_ScaleFactor. For example, see [Table 7-126](#).

Table 7-126. Factor Values

Software Function call	Functional Description	Updated Variables
SFO()	Returns MEP scale factor in the HRMSTEP register	MEP_ScaleFactor and HRMSTEP register.

To use the HRPWM feature of the ePWMs, it is recommended that the SFO function be used as described here.

Step 1. Add "Include" Files

The SFO_V8.h file needs to be included as follows. This include file is mandatory while using the SFO library function. For the SFO() to operate, the appropriate (Device)_Device.h and (Device)_Epwm_defines.h must be included in the project. These include files are optional if customized header files are used in the end applications.

Example 7-7. A Sample of How to Add "Include" Files

```
#include "F28x7x_Device.h" // F28x7x Headerfile
#include "F28x7x_EPwm_defines.h" // init defines
#include "SFO_V8.h" // SFO lib functions (needed for HRPWM)
```

Step 2. Element Declaration

Declare an integer variable for the scale factor value as shown below.

Example 7-8. Declaring an Element

```
int MEP_ScaleFactor = 0;    //scale factor value
volatile struct EPWM_REGS *ePWM[] = {0, &EPwm1Regs, &EPwm2Regs, &EPwm3Regs,
&EPwm4Regs};
```

Step 3. MEP_ScaleFactor Initialization

The SFO() function does not require a starting scale factor value in MEP_ScaleFactor. Prior to using the MEP_ScaleFactor variable in application code, SFO() should be called to drive the MEP calibration module to calculate an MEP_ScaleFactor value.

As part of the one-time initialization code prior to using MEP_ScaleFactor, include the following:

Example 7-9. Initializing With a Scale Factor Value

```
MEP_ScaleFactor initialized using function SFO ()
while (SFO() == 0) {} // MEP_ScaleFactor calculated by MEP Cal Module
```

Step 4. Application Code

While the application is running, fluctuations in both device temperature and supply voltage may be expected. To be sure that optimal Scale Factors are used for each ePWM module, the SFO function should be re-run periodically as part of a slower back-ground loop. Some examples of this are shown here.

Note

See the HRPWM_SFO example in the device-specific C/C++ header files and peripheral examples available from the TI website.

Example 7-10. SFO Function Calls

```
main ()
{
    int status;
    // User code
    // ePWM1, 2, 3, 4 are running in HRPWM mode
    // The status variable returns 1 once a new MEP_ScaleFactor has been
    // calculated by the MEP Calibration Module running SFO
    // diagnostics.
    status = SFO();
    if(status==2) {ESTOP0;}    // The function returns a 2 if MEP_ScaleFactor is greater
    // than the maximum 255 allowed (error condition)
}
```

7.4.6 Enhanced Capture (eCAP)

This chapter describes the enhanced capture (eCAP) module, which is used in systems where accurate timing of external events is important.

The enhanced capture (eCAP) module is a Type 3 eCAP.

7.4.6.1 Introduction.....	578
7.4.6.2 ECAP Integration.....	579
7.4.6.3 Description.....	581
7.4.6.4 Configuring Device Pins for the eCAP.....	581
7.4.6.5 Capture and APWM Operating Mode.....	587
7.4.6.6 Capture Mode Description.....	589
7.4.6.7 Application of the eCAP Module.....	602
7.4.6.8 Application of the APWM Mode.....	606

7.4.6.1 Introduction

7.4.6.1.1 Features

The features of the eCAP module include:

- Speed measurements of rotating machinery (for example, toothed sprockets sensed by way of Hall sensors)
- Elapsed time measurements between position sensor pulses
- Period and duty cycle measurements of pulse train signals
- Decoding current or voltage amplitude derived from duty cycle encoded current/voltage sensors

The eCAP module features described in this chapter include:

- 4-event time-stamp registers (each 32 bits)
- Edge polarity selection for up to four sequenced time-stamp capture events
- Interrupt on either of the four events
- Single-shot capture of up to four event time-stamps
- Continuous mode capture of time stamps in a four-deep circular buffer
- Absolute time-stamp capture
- Difference (Delta) mode time-stamp capture
- When not used in capture mode, the eCAP module can be configured as a single-channel PWM output

The capture functionality of the Type 1 eCAP is enhanced from the Type 0 eCAP with the following added features:

- Event filter reset bit
 - Writing a 1 to ECCTL2[CTRFILTRESET] will clear the event filter, the modulo counter, and any pending interrupts flags. Resetting the bit is useful for initialization and debug.
- Modulo counter status bits
 - The modulo counter (ECCTL2 [MODCNRSTS]) indicates which capture register will be loaded next. In the Type 0 eCAP, it was not possible to know current state of modulo counter.
- DMA trigger source
 - eCAPxDMA was added as a DMA trigger. CEVT[1-4] can be configured as the source for eCAPxDMA.
- Input multiplexer
 - ECCTL0 [INPUTSEL] selects one of 128 input signals, which are detailed in [Section 7.4.6.4](#).
- EALLOW protection
 - EALLOW protection was added to critical registers. To maintain software compatibility with Type-0, configure DEV_CFG_REGS.ECAPTYPE to make these registers unprotected.

The capture functionality of the Type 2 eCAP is enhanced from the Type 1 eCAP with the following added features:

- Added ECAPxSYNCINSEL register
 - ECAPxSYNCINSEL register is added for each eCAP to select an external SYNCIN. Every eCAP can have a separate SYNCIN signal.

The capture functionality of the Type 3 eCAP is enhanced from the Type 2 eCAP with the following added features:

- Two signal monitoring units to monitor edge, pulse width, and period
 - Signal monitoring can optionally be tightly coupled with ePWM global load strobes and trip events
- Increased the number of multiplexed capture inputs from 128 to 256
- DMA event generation capability in PWM mode of operation
- ADC SOC generation capability, to trigger ADC conversion

7.4.6.2 ECAP Integration

There are 10x ECAP modules integrated in the device. The diagram below provides a visual representation of the device integration details.

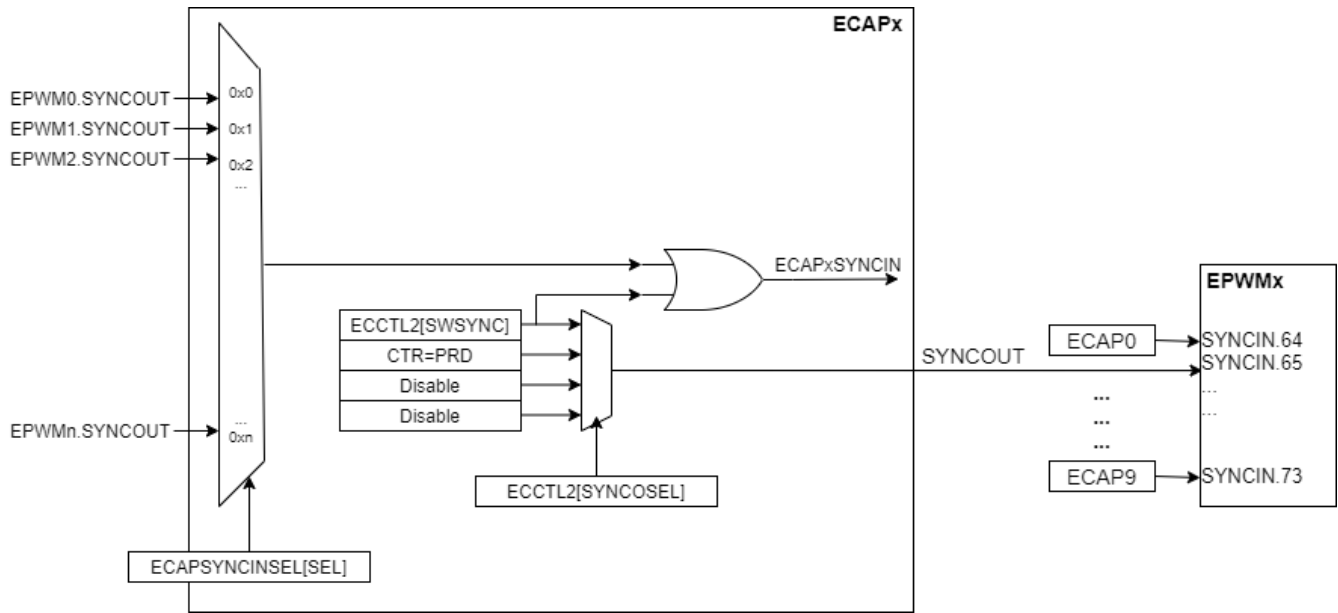

Figure 7-190. ECAP Integration Diagram

7.4.6.3 Description

The eCAP module represents one complete capture channel that can be instantiated multiple times, depending on the target device. In the context of this guide, one eCAP channel has the following independent key resources:

- Capture inputs can be connected using the Input X-BAR
- 256:1 input multiplexer
- Output X-BAR is used to configure output in APWM mode
- 32-bit time base (counter)
- 4 x 32-bit time-stamp capture registers (CAP1-CAP4)
- Four-stage sequencer (modulo4 counter) that is synchronized to external events, eCAP pin rising/falling edges.
- Modulo counter status register (MODCNRSTS) to indicate sequencer state
- Independent edge polarity (rising/falling edge) selection for all four events
- Input capture signal prescaling (from 2-62 or bypass)
- One-shot compare register (two bits) to freeze captures after 1-4 time-stamp events
- Control for continuous time-stamp captures using a four-deep circular buffer (CAP1-CAP4) scheme
- Interrupt capabilities on any of the four capture events
- Separate DMA trigger
- Signal monitoring capability for edge, pulse width, and period
- DMA event generation capability in APWM mode
- ADC SOC event generation capability, to trigger ADC conversion

7.4.6.4 Configuring Device Pins for the eCAP

The Input X-BAR connects the device pins to the module as input. Any GPIO on the device can be configured as an input. The GPIO input qualification can be set to synchronous or asynchronous mode by setting the GPxQSELn register bits. Using synchronized inputs can help with noise immunity but affects the eCAP accuracy by ± 2 cycles. The internal pull-ups can be configured in the GPyPUD register. Since the GPIO mode is used, the GPyINV register can invert the signals.

Table 7-127. eCAP Input Selection

Selection of eCAP Input	Select Index
FSI_RX0.TRIG0	0
FSI_RX0.TRIG1	1
FSI_RX0.TRIG2	2
FSI_RX0.TRIG3	3
FSI_RX1.TRIG0	4
FSI_RX1.TRIG1	5
FSI_RX1.TRIG2	6
FSI_RX1.TRIG3	7
FSI_RX2.TRIG0	8
FSI_RX2.TRIG1	9
FSI_RX2.TRIG2	10
FSI_RX2.TRIG3	11
FSI_RX3.TRIG0	12
FSI_RX3.TRIG1	13
FSI_RX3.TRIG2	14
FSI_RX3.TRIG3	15
EQEP0.SYNCQI	16
EQEP0.SYNCQS	17
EQEP1.SYNCQI	18
EQEP1.SYNCQS	19

Table 7-127. eCAP Input Selection (continued)

Selection of eCAP Input	Select Index
EQEP2.SYNCQI	20
EQEP2.SYNCQS	21
EPWM0.DELACTIVE	22
EPWM1.DELACTIVE	23
EPWM2.DELACTIVE	24
EPWM3.DELACTIVE	25
EPWM4.DELACTIVE	26
EPWM5.DELACTIVE	27
EPWM6.DELACTIVE	28
EPWM7.DELACTIVE	29
EPWM8.DELACTIVE	30
EPWM9.DELACTIVE	31
EPWM10.DELACTIVE	32
EPWM11.DELACTIVE	33
EPWM12.DELACTIVE	34
EPWM13.DELACTIVE	35
EPWM14.DELACTIVE	36
EPWM15.DELACTIVE	37
EPWM16.DELACTIVE	38
EPWM17.DELACTIVE	39
EPWM18.DELACTIVE	40
EPWM19.DELACTIVE	41
EPWM20.DELACTIVE	42
EPWM21.DELACTIVE	43
EPWM22.DELACTIVE	44
EPWM23.DELACTIVE	45
EPWM24.DELACTIVE	46
Reserved	47-53
EPWM0.SOCA	54
EPWM1.SOCA	55
EPWM2.SOCA	56
EPWM3.SOCA	57
EPWM4.SOCA	58
EPWM5.SOCA	59
EPWM6.SOCA	60
EPWM7.SOCA	61
EPWM8.SOCA	62
EPWM9.SOCA	63
EPWM10.SOCA	64
EPWM11.SOCA	65
EPWM12.SOCA	66
EPWM13.SOCA	67
EPWM14.SOCA	68
EPWM15.SOCA	69
EPWM16.SOCA	70

Table 7-127. eCAP Input Selection (continued)

Selection of eCAP Input	Select Index
EPWM17.SOCA	71
EPWM18.SOCA	72
EPWM19.SOCA	73
EPWM20.SOCA	74
EPWM21.SOCA	75
EPWM22.SOCA	76
EPWM23.SOCA	77
Reserved	78-85
EPWM0.SOCB	86
EPWM1.SOCB	87
EPWM2.SOCB	88
EPWM3.SOCB	89
EPWM4.SOCB	90
EPWM5.SOCB	91
EPWM6.SOCB	92
EPWM7.SOCB	93
EPWM8.SOCB	94
EPWM9.SOCB	95
EPWM10.SOCB	96
EPWM11.SOCB	97
EPWM12.SOCB	98
EPWM13.SOCB	99
EPWM14.SOCB	100
EPWM15.SOCB	101
EPWM16.SOCB	102
EPWM17.SOCB	103
EPWM18.SOCB	104
EPWM19.SOCB	105
EPWM20.SOCB	106
EPWM21.SOCB	107
EPWM22.SOCB	108
EPWM23.SOCB	109
Reserved	110-117
SDFM0.COMP1H	118
SDFM0.COMP1L	119
SDFM0.COMPZ1	120
SDFM0.COMP2H	121
SDFM0.COMP2L	122
SDFM0.COMPZ2	123
SDFM0.COMP3H	124
SDFM0.COMP3L	125
SDFM0.COMPZ3	126
SDFM0.COMP4H	127
SDFM0.COMP4L	128
SDFM0.COMPZ4	129

ADVANCE INFORMATION

Table 7-127. eCAP Input Selection (continued)

Selection of eCAP Input	Select Index
SDFM1.COMP1H	130
SDFM1.COMP1L	131
SDFM1.COMPZ1	132
SDFM1.COMP2H	133
SDFM1.COMP2L	134
SDFM1.COMPZ2	135
SDFM1.COMP3H	136
SDFM1.COMP3L	137
SDFM1.COMPZ3	138
SDFM1.COMP4H	139
SDFM1.COMP4L	140
SDFM1.COMPZ4	141
CMPSSA0.CTRIPL	142
CMPSSA0.CTRIPH	143
CMPSSA1.CTRIPL	144
CMPSSA1.CTRIPH	145
CMPSSA2.CTRIPL	146
CMPSSA2.CTRIPH	147
CMPSSA3.CTRIPL	148
CMPSSA3.CTRIPH	149
CMPSSA4.CTRIPL	150
CMPSSA4.CTRIPH	151
CMPSSA5.CTRIPL	152
CMPSSA5.CTRIPH	153
Reserved	154-161
CMPSSB0.CTRIPL	162
CMPSSB0.CTRIPH	163
CMPSSB1.CTRIPL	164
CMPSSB1.CTRIPH	165
CMPSSB2.CTRIPL	166
CMPSSB2.CTRIPH	167
CMPSSB3.CTRIPL	168
CMPSSB3.CTRIPH	169
CMPSSB4.CTRIPL	170
CMPSSB4.CTRIPH	171
CMPSSB5.CTRIPL	172
CMPSSB5.CTRIPH	173
Reserved	174-181
ADC0.ADCTRIPEVT0	182
ADC0.ADCTRIPEVT1	183
ADC0.ADCTRIPEVT2	184
ADC0.ADCTRIPEVT3	185
ADC1.ADCTRIPEVT0	186
ADC1.ADCTRIPEVT1	187
ADC1.ADCTRIPEVT2	188

Table 7-127. eCAP Input Selection (continued)

Selection of eCAP Input	Select Index
ADC1.ADCTRIPEVT3	189
ADC2.ADCTRIPEVT0	190
ADC2.ADCTRIPEVT1	191
ADC2.ADCTRIPEVT2	192
ADC2.ADCTRIPEVT3	193
ADC3.ADCTRIPEVT0	194
ADC3.ADCTRIPEVT1	195
ADC3.ADCTRIPEVT2	196
ADC3.ADCTRIPEVT3	197
ADC4.ADCTRIPEVT0	198
ADC4.ADCTRIPEVT1	199
ADC4.ADCTRIPEVT2	200
ADC4.ADCTRIPEVT3	201
INPUTXBAR.OUT0	202
INPUTXBAR.OUT1	203
INPUTXBAR.OUT2	204
INPUTXBAR.OUT3	205
INPUTXBAR.OUT4	206
INPUTXBAR.OUT5	207
INPUTXBAR.OUT6	208
INPUTXBAR.OUT7	209
INPUTXBAR.OUT8	210
INPUTXBAR.OUT9	211
INPUTXBAR.OUT10	212
INPUTXBAR.OUT11	213
INPUTXBAR.OUT12	214
INPUTXBAR.OUT13	215
INPUTXBAR.OUT14	216
INPUTXBAR.OUT15	217
INPUTXBAR.OUT16	218
INPUTXBAR.OUT17	219
INPUTXBAR.OUT18	220
INPUTXBAR.OUT19	221
INPUTXBAR.OUT20	222
INPUTXBAR.OUT21	223
INPUTXBAR.OUT22	224
INPUTXBAR.OUT23	225
INPUTXBAR.OUT24	226
INPUTXBAR.OUT25	227
INPUTXBAR.OUT26	228
INPUTXBAR.OUT27	229
INPUTXBAR.OUT28	230
INPUTXBAR.OUT29	231
INPUTXBAR.OUT30	232
INPUTXBAR.OUT31	233

Table 7-127. eCAP Input Selection (continued)

Selection of eCAP Input	Select Index
Reserved	234-256

The Output X-BAR must be used to connect output signals to the OUTPUTXBARx output locations. The GPIO mux must then be configured to connect the OUTPUTXBARx lines to any of several IO pins with the GPIO mux. To avoid glitches on the pins, the GPyGMUX bits must be configured first (while keeping the corresponding GPyMUX bits at the default of zero), followed by writing the GPyMUX register to the desired value.

See the *General-Purpose Input/Output (GPIO)* chapter for more details on GPIO mux, GPIO settings, and XBAR configuration.

Note

ECAPxIN has to be at least 2*SYSCLK cycles wide to be properly captured by the ECAP module; otherwise, the input pulse can get missed from sampling by the SYSCLK.

7.4.6.5 Capture and APWM Operating Mode

You can use the eCAP module resources to implement a single-channel PWM generator (with 32-bit capabilities) when it is not being used for input captures. The counter operates in count-up mode, providing a time-base for asymmetrical pulse width modulation (PWM) waveforms. The CAP1 and CAP2 registers become the active period and compare registers, respectively, while CAP3 and CAP4 registers become the period and compare shadow registers, respectively. Figure 7-191 is a high-level view of both the capture and auxiliary pulse-width modulator (APWM) modes of operation.

Figure 7-192 further describes the output of the eCAP in APWM mode based on the CMP and PRD values.

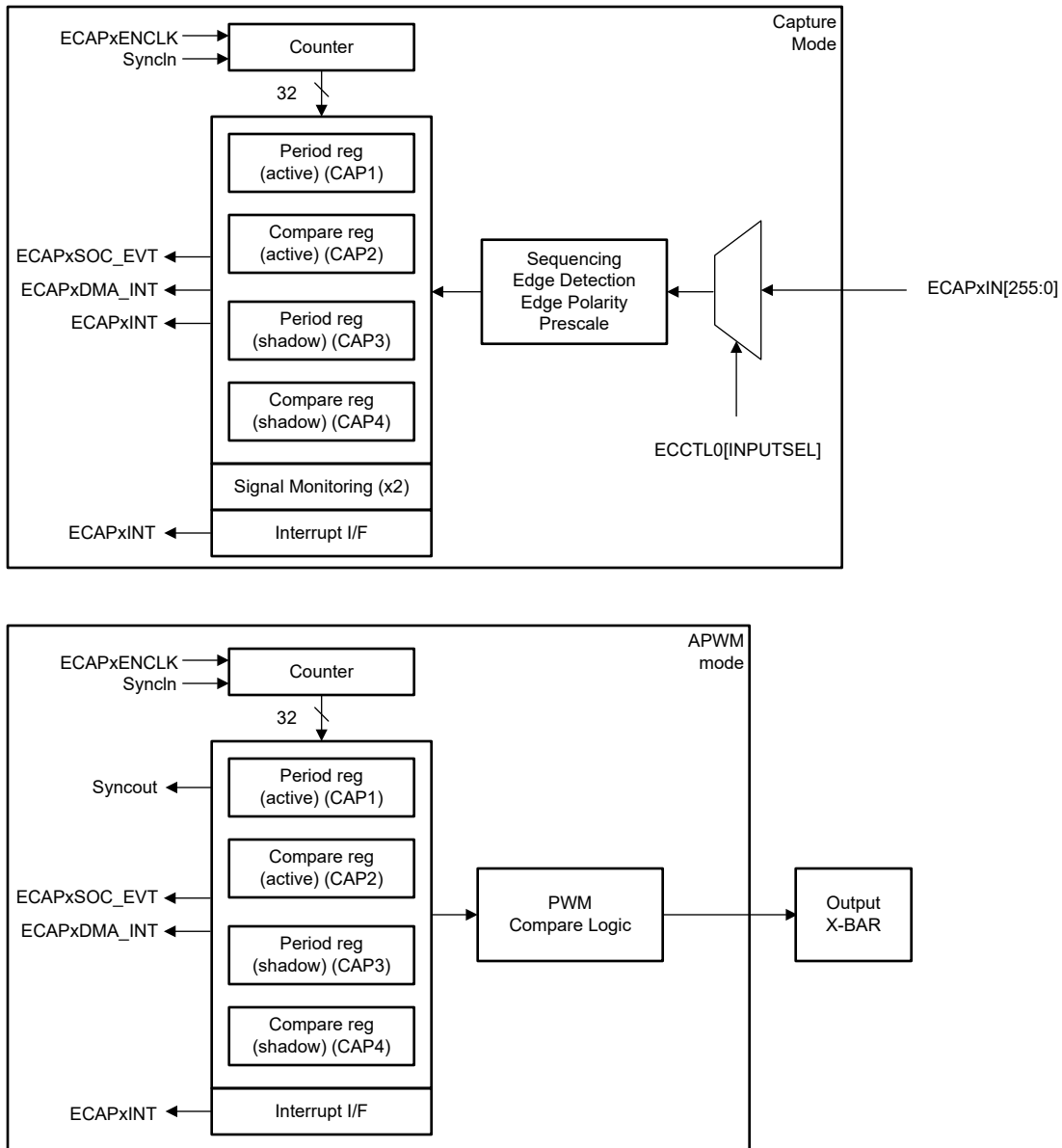

- A. A single pin is shared between CAP and APWM functions. In capture mode, it is an input; in APWM mode, it is an output.
- B. In APWM mode, writing any value to CAP1/CAP2 active registers also writes the same value to the corresponding shadow registers CAP3/CAP4. This emulates immediate mode. Writing to the shadow registers CAP3/CAP4 invokes the shadow mode.

Figure 7-191. Capture and APWM Modes of Operation

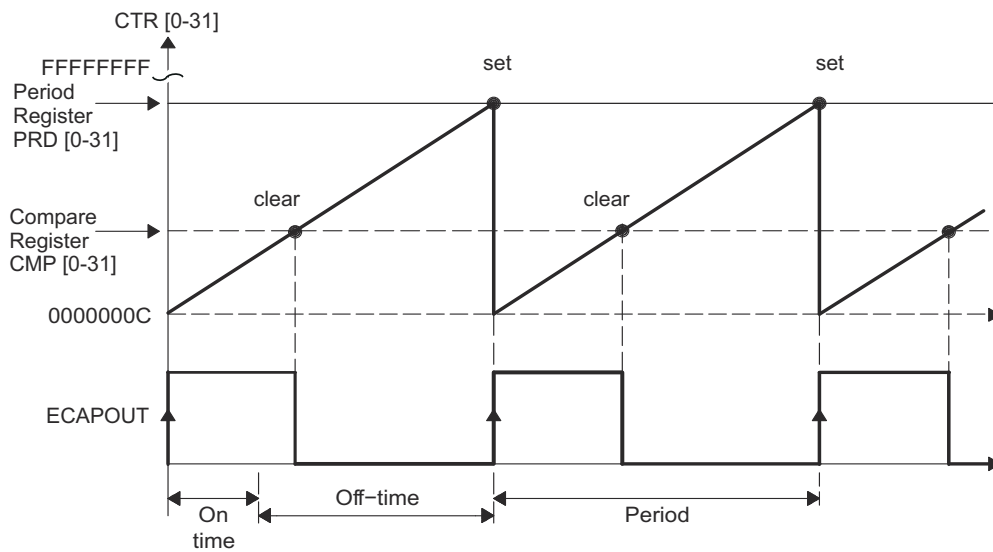
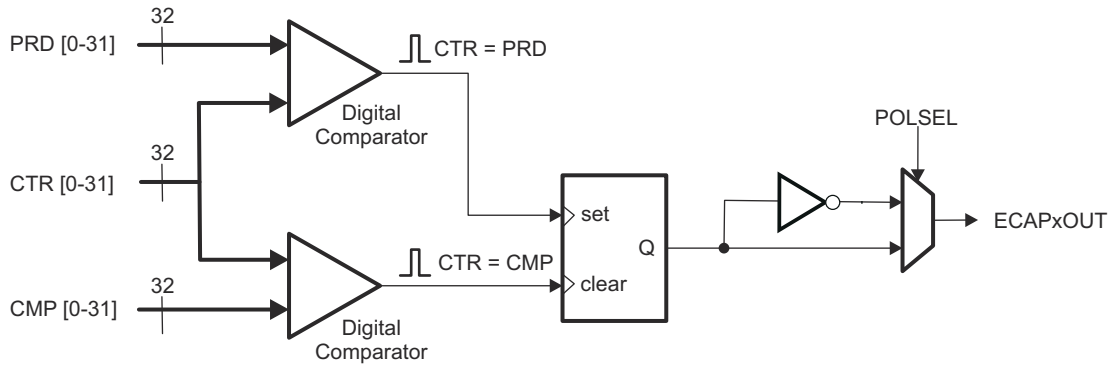

Figure 7-192. Counter Compare and PRD Effects on the eCAP Output in APWM Mode

ADVANCE INFORMATION

7.4.6.6 Capture Mode Description

Figure 7-193 shows the various components that implement the capture function.

Figure 7-193. eCAP Block Diagram

7.4.6.6.1 Event Prescaler

An input capture signal (pulse train) can be prescaled by $N = 2-62$ (in multiples of 2) or can bypass the prescaler. This is useful when very high frequency signals are used as inputs. Figure 7-194 shows a functional diagram and Figure 7-195 shows the operation of the prescale function. The event prescaler can be reset by setting the ECCTL2.CTRFILTRESET register bit.

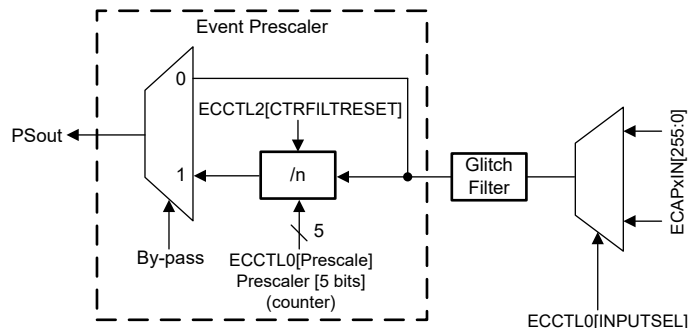

- A. When a prescale value of 1 is chosen (ECCTL1[13:9] = 0,0,0,0,0), the input capture signal bypasses the prescale logic completely.
- B. The first Rise edge after Prescale configuration change is not passed to Capture logic, prescaler value takes into effect on the second rising edge after the configuration.

Figure 7-194. Event Prescale Control

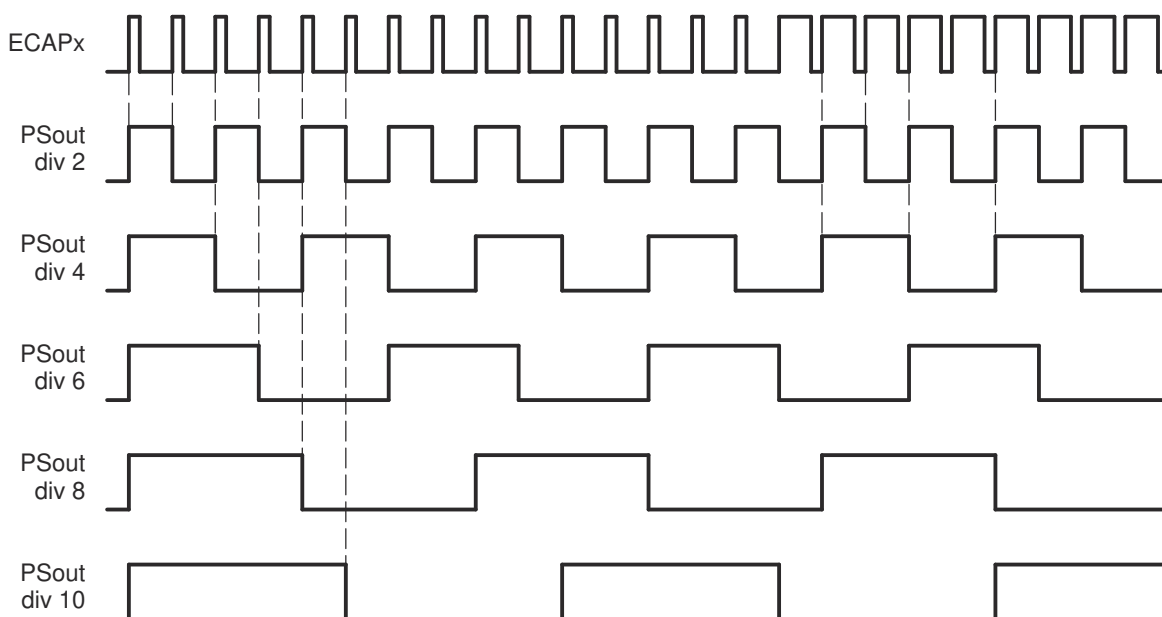

Figure 7-195. Prescale Function Waveforms

7.4.6.6.2 Glitch Filter

A glitch filter is included to reduce internal and external noise glitches on the source signal being measured via eCAP.

The glitch filter can be used to filter out glitches of a specified time period in terms of SYSCLK cycles. The supported range is from 1 to 15 cycles. By default, the glitch filter is disabled (ECCCTL0[QUALPRD]=0) to maintain compatibility.

Note

The glitch filter should be disabled when using HRCAP as it changes the pulse width of the signal. Also note that when enabled, the glitch filter delays the signal by $QUALPRD+1$ which must be accounted for in applications utilizing the feature.

7.4.6.6.3 Edge Polarity Select and Qualifier

Functionality and features include:

- Four independent edge polarity (rising edge/falling edge) selection muxes are used, one for each capture event.
- Each edge (up to 4) is event qualified by the Modulo4 sequencer.
- The edge event is gated to its respective CAPx register by the Mod4 counter. The CAPx register is loaded on the falling edge.

7.4.6.6.4 Continuous/One-Shot Control

Operation of eCAP in Continuous/One-Shot mode:

- The Mod4 (2-bit) counter is incremented via edge qualified events (CEVT1-CEVT4).
- The Mod4 counter continues counting (0->1->2->3->0) and wraps around unless stopped.
- During one-shot operation, a 2-bit stop register (STOP_WRAP) is used to compare the Mod4 counter output, and when equal, stops the Mod4 counter and inhibits further loads of the CAP1-CAP4 registers. In this mode if TSCCTR counter is configured to reset on capture event (CEVTx) by configuring ECCTL1.CTRRSTx bit, it will still keep resetting the TSCCTR counter on capture event (CEVTx) after the STOP_WRAP value is reached and re-arm (REARM) has not occurred.

The continuous/one-shot block controls the start, stop and reset (zero) functions of the Mod4 counter, via a mono-shot type of action that can be triggered by the stop-value comparator and re-armed via software control.

Once armed, the eCAP module waits for 1-4 (defined by stop-value) capture events before freezing both the Mod4 counter and contents of CAP1-4 registers (time stamps).

Re-arming prepares the eCAP module for another capture sequence. Also, re-arming clears (to zero) the Mod4 counter and permits loading of CAP1-4 registers again, providing the CAPLDEN bit is set.

In continuous mode, the Mod4 counter continues to run (0->1->2->3->0, the one-shot action is ignored, and capture values continue to be written to CAP1-4 in a circular buffer sequence.

Figure 7-196. Details of the Continuous/One-shot Block

7.4.6.6.5 32-Bit Counter and Phase Control

This counter provides the time-base for event captures, and is clocked using the system clock.

A phase register is provided to achieve synchronization with other counters using a hardware and software forced sync. This is useful in APWM mode when a phase offset between modules is needed.

On any of the four event loads, an option to reset the 32-bit counter is given. This is useful for time difference capture. The 32-bit counter value is captured first, then the counter value is reset to 0 by any of the LD1-LD4 signals.

7.4.6.6.6 CAP1-CAP4 Registers

These 32-bit registers are supplied by the 32-bit counter timer bus, CTR[0-31], and are loaded (capture a time-stamp) when their respective LD inputs are strobed.

Control bit CAPLDEN can inhibit loading of the capture registers. During one-shot operation, this bit is cleared (loading is inhibited) automatically when a stop condition occurs, StopValue = Mod4.

CAP1 and CAP2 registers become the active period and compare registers, respectively, in APWM mode.

CAP3 and CAP4 registers become the respective shadow registers (APRD and ACMP) for CAP1 and CAP2 during APWM operation.

7.4.6.6.7 eCAP Synchronization

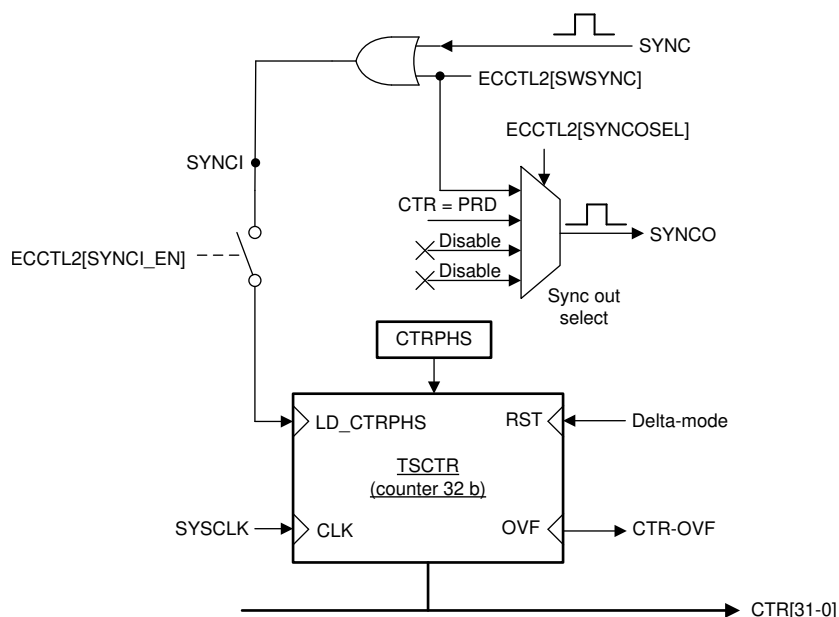

Figure 7-197. Details of the Counter and Synchronization Block

eCAP modules can be synchronized with each other by selecting a common SYNCIN source. SYNCIN source for eCAP can be either software sync-in or external sync-in. The external sync-in signal can come from EPWM. The SWSYNC of the eCAP module is logical ORed with the SYNC signal as shown in [#unique_754/unique_754_Connect_42_DETAILS_COUNTER_SYNCreferenceTitle](#). The SYNC signal is defined by the selection of ECAPxSYNCSINSEL[SEL] as shown in [Figure 7-198](#).

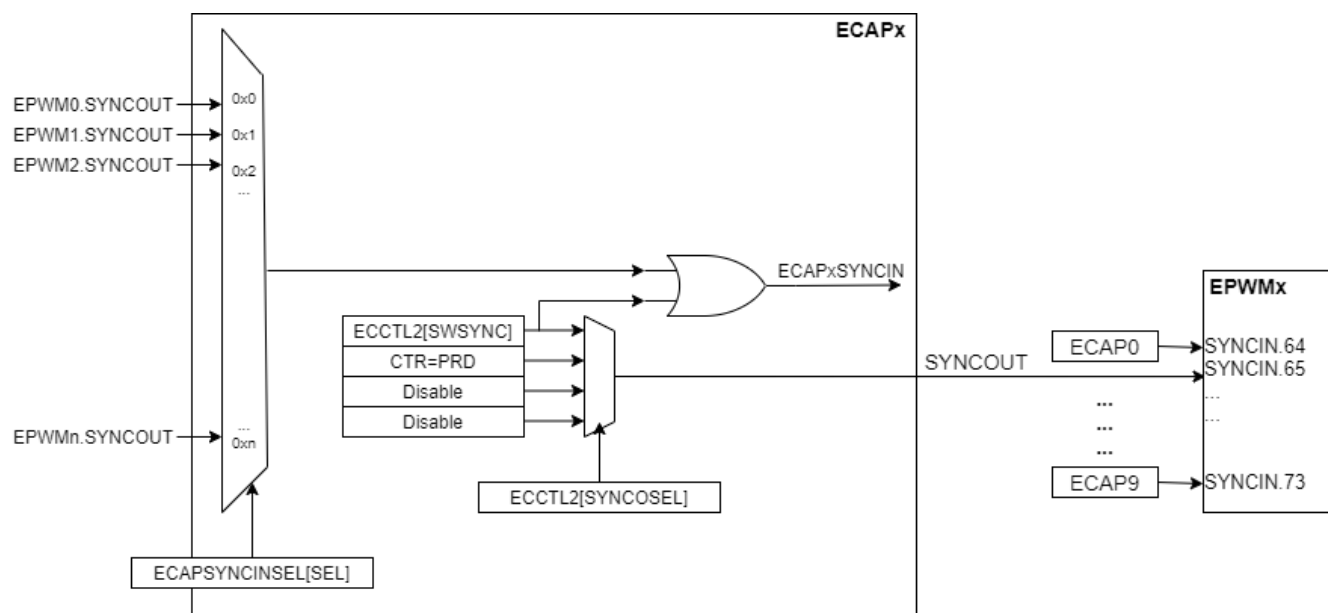

Figure 7-198. eCAP Synchronization Scheme

7.4.6.6.7.1 Example 1 - Using SWSYNC with ECAP Module

Implement the following steps to use SWSYNC with ECAP1 and ECAP2.

- Configure ECAP[1..2].ECAPSYNCSINSEL.SEL = 0x0 to disable external SYNCIN coming to eCAP1.
- Configure ECAP[1..2].ECCTL2.SWSYNC = 0x1, to force Software Synchronization of the TSCTR counter.

To use SWSYNC with other eCAP modules, make sure that the previous eCAP chain is not generating a SYNCOUT signal that interferes with the software synchronization.

7.4.6.6.8 Interrupt Control

Operation and features of the eCAP interrupt control include (see [Figure 7-199](#)):

- An interrupt can be generated on capture events (CEVT1-CEVT4, CTROVF) or APWM events (CTR = PRD, CTR = CMP).
- An interrupt can be generated on signal monitoring errors (MUNIT_1_ERROR_EVT1, MUNIT_1_ERROR_EVT1, MUNIT_2_ERROR_EVT1, MUNIT_2_ERROR_EVT2)
- A counter overflow event (FFFFFFFF->00000000) is also provided as an interrupt source (CTROVF).
- The capture events are edge and sequencer-qualified (ordered in time) by the polarity select and Mod4 gating, respectively.
- One of these events can be selected as the interrupt source (from the eCAPx module) going to the PIE.
- Seven interrupt events (CEVT1, CEVT2, CEVT3, CEVT4, CNTOVF, CTR=PRD, CTR=CMP) can be generated.
- An additional four interrupt events (MUNIT_1_ERROR_EVT1, MUNIT_1_ERROR_EVT1, MUNIT_2_ERROR_EVT1, MUNIT_2_ERROR_EVT2) can be generated from the signal monitoring unit.
- The interrupt enable register (ECEINT) is used to enable/disable individual interrupt event sources. The interrupt flag register (ECFLG) indicates if any interrupt event has been latched and contains the global interrupt flag bit (INT). An interrupt pulse is generated to the PIE only if any of the interrupt events are enabled, the flag bit is 1, and the INT flag bit is 0. The interrupt service routine must clear the global interrupt flag bit and the serviced event via the interrupt clear register (ECCLR) before any other interrupt pulses are generated. All interrupt flags will be cleared upon an event filter reset by writing a "1" to ECCTL2[CLRFILTRESET]. You can force an interrupt event via the interrupt force register (ECFRC). This is useful for test purposes.

Note

The CEVT1, CEVT2, CEVT3, CEVT4 flags are only active in capture mode (ECCTL2[CAP/APWM == 0]). The CTR=PRD, CTR=CMP flags are only valid in APWM mode (ECCTL2[CAP/APWM == 1]). CNTOVF flag is valid in both modes.

Figure 7-199. Interrupts in eCAP Module

7.4.6.6.9 DMA Interrupt

On Type 0 eCAP modules, the CPU was required to begin data transfers using DMA. New to the Type 1 eCAP, a separate DMA Trigger (ECAP_DMA_INT) enables continuous transfer of capture data from eCAP registers to on-chip memory using DMA. Any one of the four available interrupt events (CEVT1, CEVT2, CEVT3 and CEVT4) can be selected as the trigger source for ECAP_DMA_INT using ECCTL2 [DMAEVTSEL].

New to the Type 3 eCAP is the ability to trigger DMA events in APWM mode. Any one of three available events (period match, compare match, or both) can be selected as the trigger source for ECAP_DMA_INT using ECCTL2 [DMAEVTSEL].

7.4.6.6.10 ADC SOC Event

Type 3 introduces the capability to generate ADC SOC events in capture mode and in APWM mode of operation. The ability to start ADC conversions allows for increased APWM functionality, as well as the ability to synchronize capture events with ADC samples.

In capture mode, one of the four available interrupt events (CEVT1, CEVT2, CEVT3, and CEVT4) can be selected as ECAP_SOC_EVT using ECCCTL0[SOCEVTSEL].

In APWM mode, any one of three available events (period match, compare match, or both) can be selected as ECAP_SOC_EVT using ECCCTL0[SOCEVTSEL].

7.4.6.6.11 Shadow Load and Lockout Control

In capture mode, this logic inhibits (locks out) any shadow loading of CAP1 or CAP2 from APRD and ACMP registers, respectively.

In APWM mode, shadow loading is active and two choices are permitted:

- Immediate - APRD or ACMP are transferred to CAP1 or CAP2 immediately upon writing a new value.
- On period equal, $CTR[31:0] = PRD[31:0]$.

7.4.6.6.12 APWM Mode Operation

Main operating highlights of the APWM section:

- The time-stamp counter bus is made available for comparison by way of 2 digital (32-bit) comparators.
- When CAP1/2 registers are not used in capture mode, their contents can be used as Period and Compare values in APWM mode.
- Double buffering is achieved via shadow registers APRD and ACMP (CAP3/4). The shadow register contents are transferred over to CAP1/2 registers, either immediately upon a write, or on a $CTR = PRD$ trigger.
- In APWM mode, writing to CAP1/CAP2 active registers will also write the same value to the corresponding shadow registers CAP3/CAP4. This emulates immediate mode. Writing to the shadow registers CAP3/CAP4 will invoke the shadow mode.
- During initialization, you must write to the active registers for both period and compare. This automatically copies the initial values into the shadow values. For subsequent compare updates, during run-time, you only need to use the shadow registers.

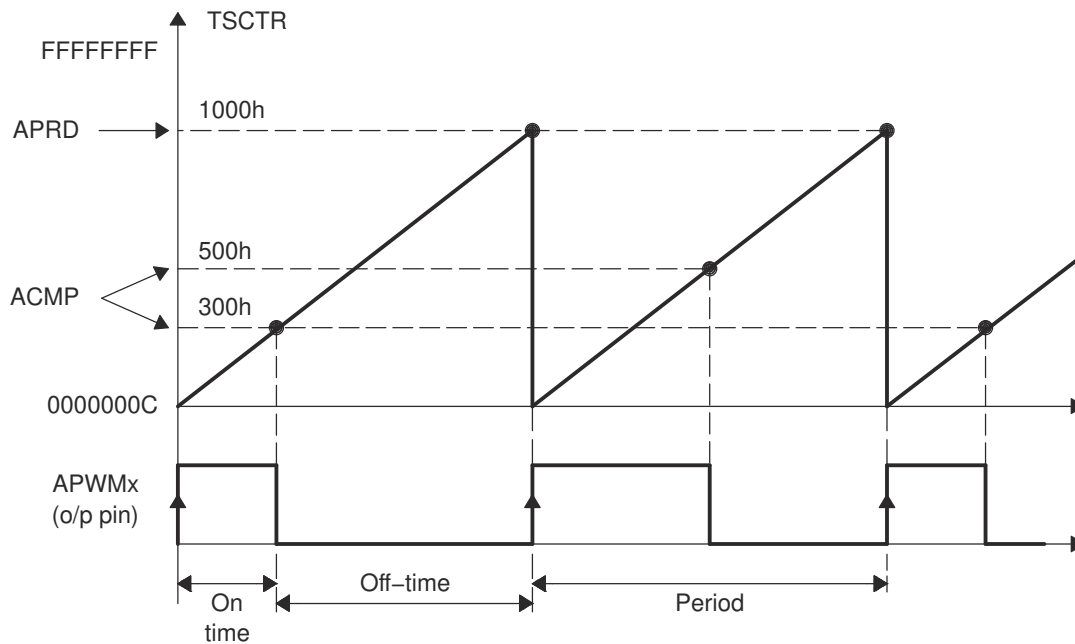

Figure 7-200. PWM Waveform Details Of APWM Mode Operation

The behavior of APWM active high mode (APWMPOL == 0) is as follows:

CMP = 0x00000000, output low for duration of period (0% duty)

CMP = 0x00000001, output high 1 cycle

CMP = 0x00000002, output high 2 cycles

CMP = PERIOD, output high except for 1 cycle (<100% duty)

CMP = PERIOD+1, output high for complete period (100% duty)

CMP > PERIOD+1, output high for complete period

The behavior of APWM active low mode (APWMPOL == 1) is as follows:

CMP = 0x00000000, output high for duration of period (0% duty)

CMP = 0x00000001, output low 1 cycle

CMP = 0x00000002, output low 2 cycles

CMP = PERIOD, output low except for 1 cycle (<100% duty)

CMP = PERIOD+1, output low for complete period (100% duty)

CMP > PERIOD+1, output low for complete period

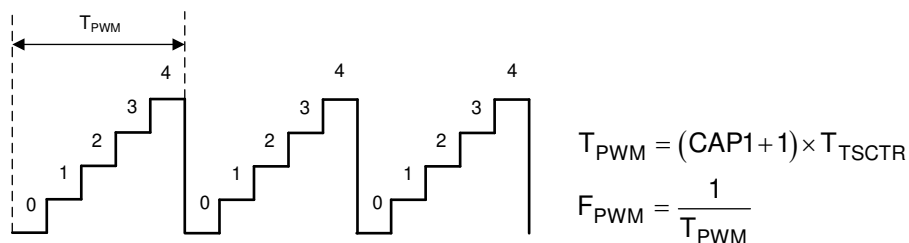

Figure 7-201. Time-Base Frequency and Period Calculation

7.4.6.6.13 Signal Monitoring Unit

The signal monitoring unit can be used for edge, pulse width, and period monitoring of ECAP input signals. This allows for detection that is useful for many applications. For example, EPWM pulse width boundary monitoring can be accomplished for safety applications.

The high-level features of the signal monitoring unit include:

- Measure pulse width (high or low) and check if it is in expected range
- Measure period (rise-to-rise or fall-to-fall) and check if it is in expected range
- Monitor signal edge (rise or fall) and check if it occurs in a user-programmed time window

7.4.6.6.13.1 Pulse Width and Period Monitoring

The signal monitoring unit has the ability to measure pulse width (either low or high) or period (rise-to-rise edge or fall-to-fall edge) and automatically generate an error when the pulse width is outside of a programmable expected range.

The expected pulse width range is programmable using the following configuration registers (or their respective shadow registers):

- MUNIT_#_MIN programs the minimum pulse width capture value
- MUNIT_#_MAX programs the maximum pulse width capture value

Any pulse width outside of these programmed bounds will trigger one of two error events:

- MUNIT_#_ERROR_EVT1 generated when measured pulse width is less than MUNIT_#_MIN
- MUNIT_#_ERROR_EVT2 generated when measured pulse width is greater than MUNIT_#_MAX

The following diagram provides an example in which the measured pulse width exceeds the MAX value, generating an ERROR_EVT2 event.

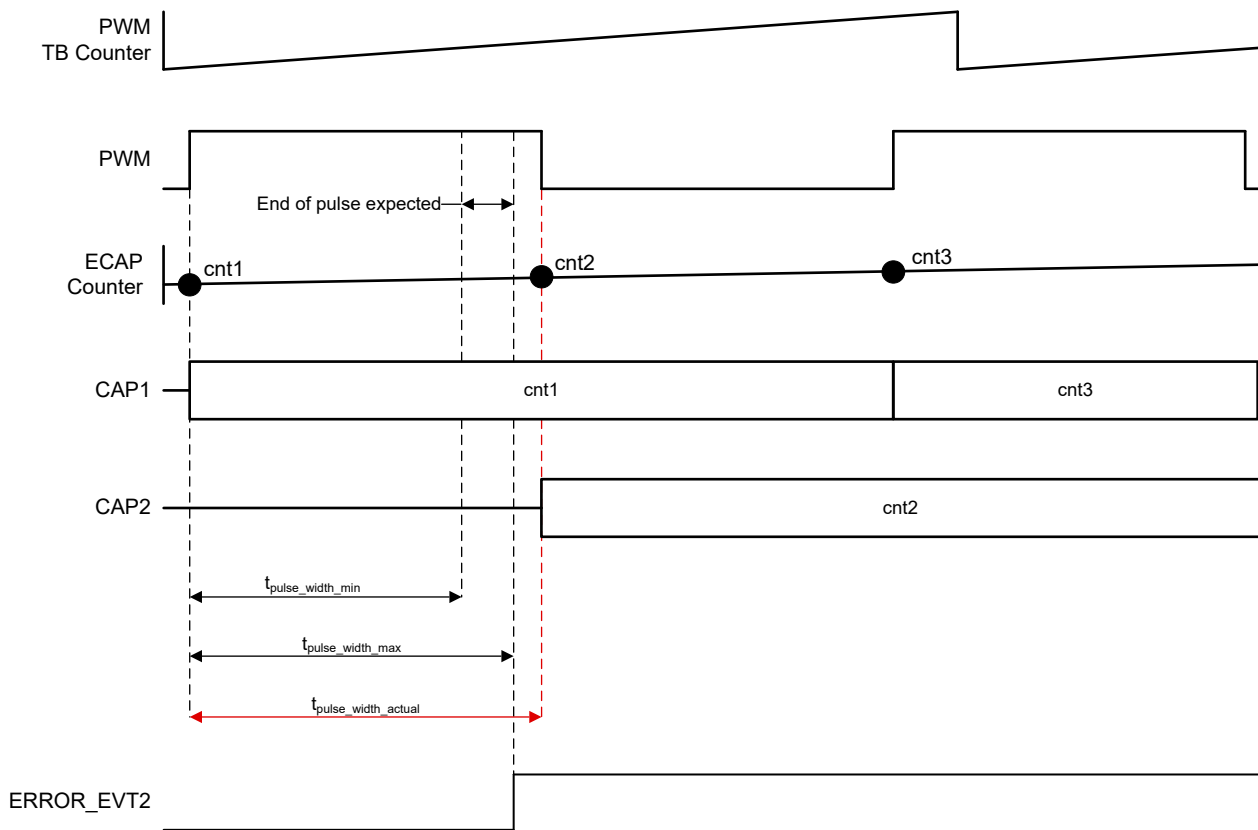

Figure 7-202. ECAP Signal Monitoring Unit Pulse Width Error Example

Configuration Requirements

To enable this mode, the following settings must be configured:

- Absolute mode must be set for the ECAP counter, so that the counter is free running and does not get reset on any capture events
- Continuous mode should be enabled (one-shot mode can be used, but is not recommended given its short duration)
- Sync feature for the counter should be disabled (ECCTL2.SYNCI_EN = 0)
- A minimum of two captures should be enabled (ECCTL2.STOP_WRAP >= 1, and at least CAP1 and CAP2 enabled)

- Capture Edge (ECCTL1.CAPxPOL) of used capture modules (any of CAP1 to CAP4) must be configured to capture two edges of interest
 - High pulse: one rising edge and one falling edge
 - Low pulse: one rising edge and one falling edge
 - Period rise-to-rise: two rising edges
 - Period fall-to-fall: two falling edges

Note

If a pulse width is greater than the MAX value, a second edge may arrive late or never even occur. Because of this, the DISABLE_EARLY_MAX_ERR field in the MUNIT_#_CTL register can be used to choose when a "MAX" error occurs. By setting the bit to 0, an error is generated as soon as the pulse width is greater than the specified max value. By setting the bit to 1, an error is generated when the second event has occurred.

7.4.6.6.13.2 Edge Monitoring

The signal monitoring unit has the ability to monitor and check if a rise or fall edge occurs within a specified time window and automatically generate an error when an edge occurs outside of this window.

The time window of an expected edge event can be programmed using the following configuration registers (or their respective shadow registers):

- MUNIT_#_MIN programs the minimum pulse width capture value
- MUNIT_#_MAX programs the maximum pulse with capture value

Any edge that occurs outside of these programmed bounds will trigger the following error event:

- MUNIT_#_ERROR_EVT1 generated when edge occurs outside the bounds of MUNIT_#_MIN and MUNIT_#_MAX.

Additionally, ERROR_EVT2 is generated if either MIN or MAX did not occur between two sync events.

The following diagram provides an example in which a rising edge does not occur during the expected window, generating an ERROR_EVT1 event.

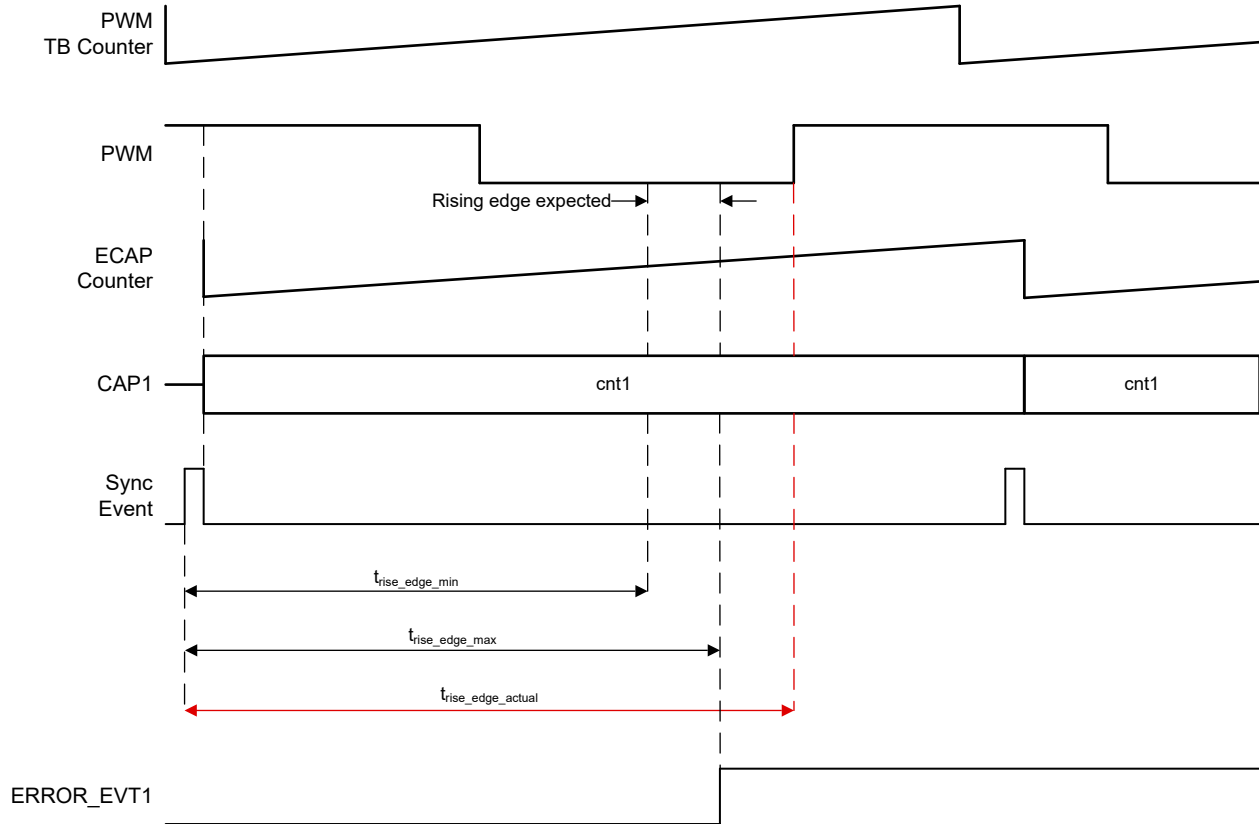

Figure 7-203. ECAP Signal Monitoring Unit Edge Error Example

Configuration Requirements

To enable this mode, the following settings must be configured:

- The ECAP counter must be synced with an EPWM module
- Absolute mode must be set for the ECAP counter, so that the counter is free running and does not get reset on any capture events
- Continuous mode should be enabled (one-shot mode can be used, but is not recommended given its short duration)
- A minimum of one captures should be enabled (ECCTL2.STOP_WRAP >= 0, and at least CAP1 enabled)
- Capture Edge (ECCTL1.CAPxPOL) of used capture modules (any of CAP1 to CAP4) must be configured to capture an edge of interest
- The time window defined using MIN and MAX should not cross the sync boundary

Note

The following are important considerations when configuring the edge monitoring feature:

- If the EPWM counter or ECAP counter are loaded with a non-zero phase value, the MIN and MAX values must be adjusted accordingly in SW. This also applies when the glitch filter is enabled, as the glitch filter delays the signal by QUALPRD+1
- The edge monitoring logic will restart on a sync event. This is to avoid any deadlock in case MIN, MAX, or both events do not occur between two sync events. ERROR_EVT2 is generated if MIN or MAX match did not occur between two sync events
- The time window defined using MIN and MAX should not cross the sync boundary

7.4.6.7 Application of the eCAP Module

The following sections will provide applications examples to show how to operate the eCAP module.

7.4.6.7.1 Example 1 - Absolute Time-Stamp Operation Rising Edge Trigger

Figure 7-204 shows an example of continuous capture operation (Mod4 counter wraps around). In this figure, TSCTR counts-up without resetting and capture events are qualified on the rising edge only, this gives period (and frequency) information.

On an event, the TSCTR contents (time-stamp) is first captured, then Mod4 counter is incremented to the next state. When the TSCTR reaches FFFFFFFF (maximum value), it wraps around to 00000000 (not shown in Figure 7-204), if this occurs, the CTROVF (counter overflow) flag is set, and an interrupt (if enabled) occurs, CTROVF (counter overflow) Flag is set, and an Interrupt (if enabled) occurs. Captured Time-stamps are valid at the point indicated by the diagram (after the 4th event), hence event CEVT4 can conveniently be used to trigger an interrupt and the CPU can read data from the CAPx registers.

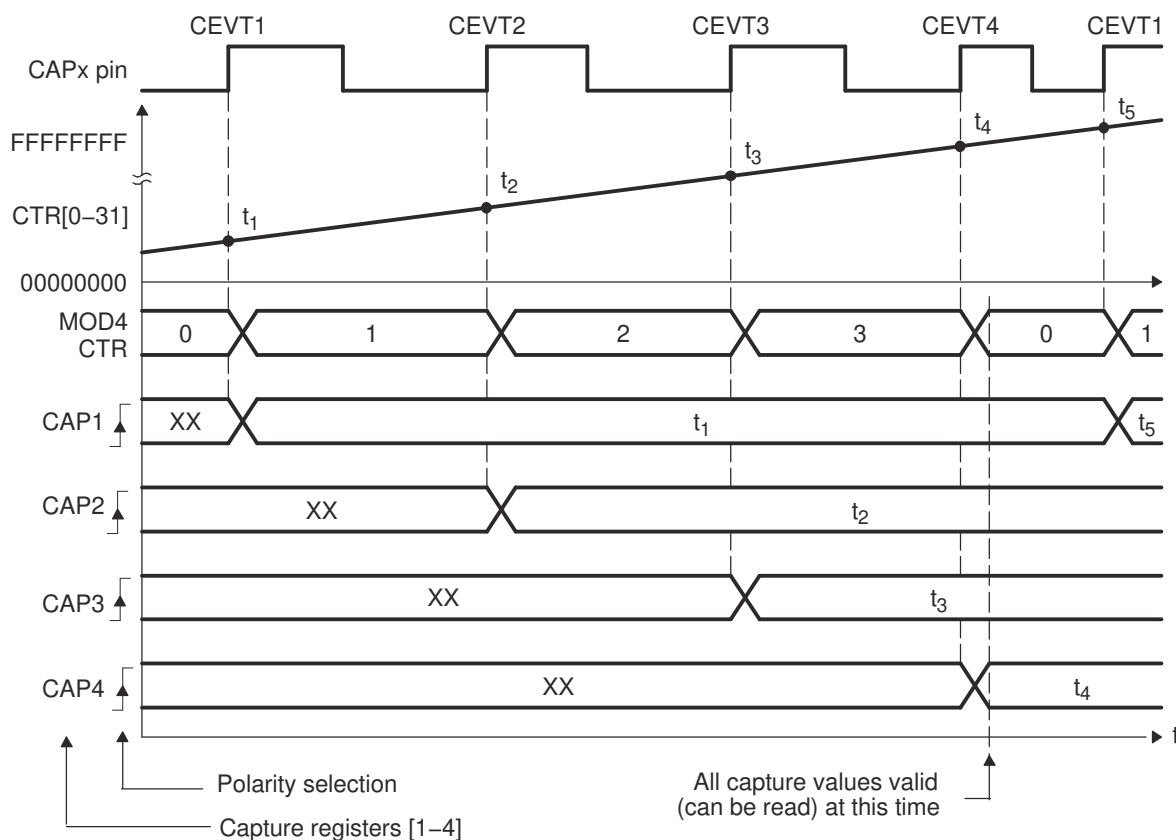
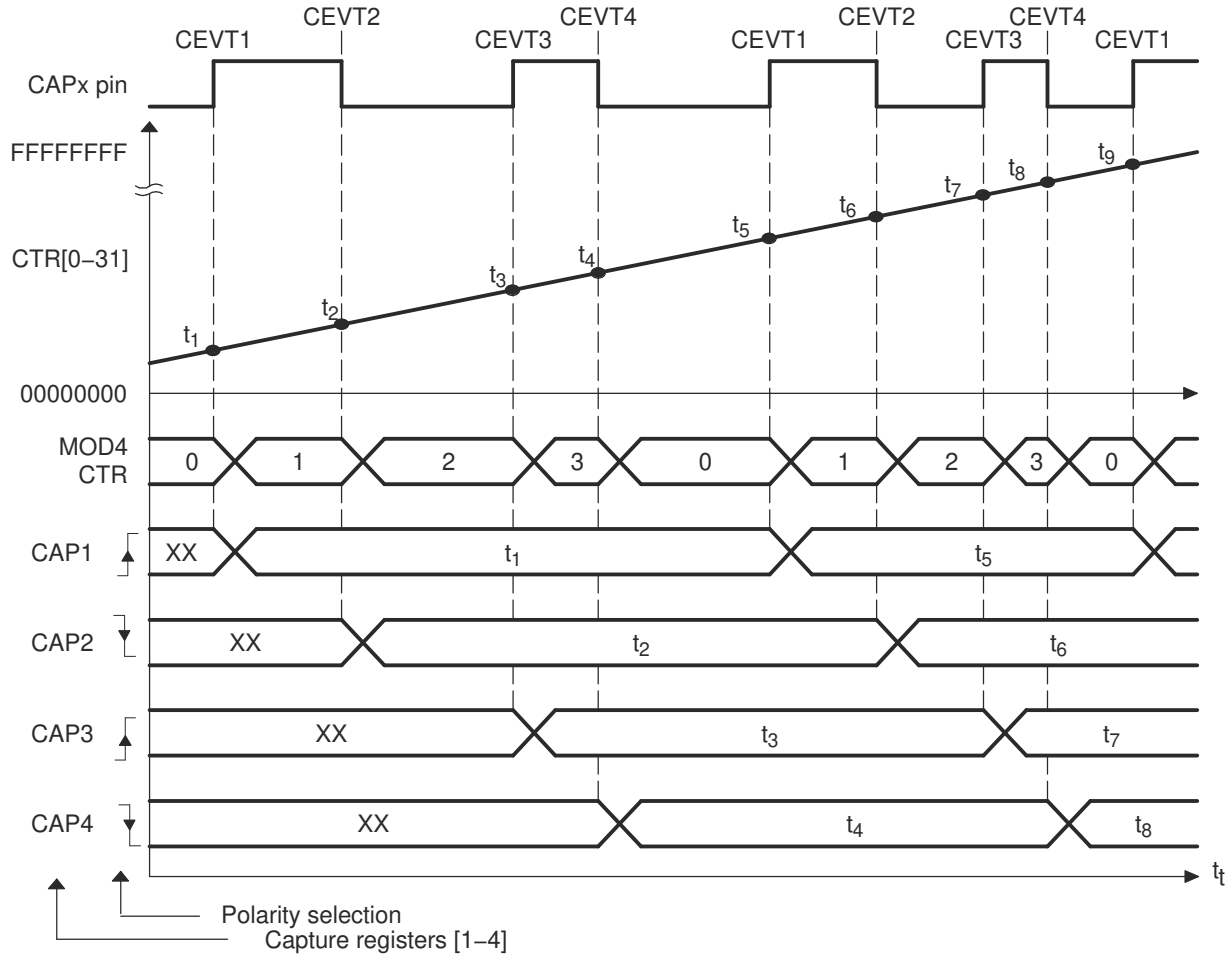

Figure 7-204. Capture Sequence for Absolute Time-stamp and Rising Edge Detect

7.4.6.7.2 Example 2 - Absolute Time-Stamp Operation Rising and Falling Edge Trigger

In Figure 7-205, the eCAP operating mode is almost the same as in the previous section except capture events are qualified as either rising or falling edge, this now gives both period and duty cycle information, that is: Period1 = $t_3 - t_1$, Period2 = $t_5 - t_3$, ...and so on. Duty Cycle1 (on-time %) = $(t_2 - t_1) / \text{Period1} \times 100\%$, and so on. Duty Cycle1 (off-time %) = $(t_3 - t_2) / \text{Period1} \times 100\%$, and so on.



ADVANCE INFORMATION

Figure 7-205. Capture Sequence for Absolute Time-stamp With Rising and Falling Edge Detect

7.4.6.7.3 Example 3 - Time Difference (Delta) Operation Rising Edge Trigger

Figure 7-206 shows how the eCAP module can be used to collect Delta timing data from pulse train waveforms. Here Continuous Capture mode (TSCTR counts-up without resetting, and Mod4 counter wraps around) is used. In Delta-time mode, TSCTR is Reset back to Zero on every valid event. Here Capture events are qualified as Rising edge only. On an event, TSCTR contents (Time-Stamp) is captured first, and then TSCTR is reset to Zero. The Mod4 counter then increments to the next state. If TSCTR reaches FFFFFFFF (Max value), before the next event, it wraps around to 00000000 and continues, a CNTOVF (counter overflow) Flag is set, and an Interrupt (if enabled) occurs. The advantage of Delta-time Mode is that the CAPx contents directly give timing data without the need for CPU calculations, that is, Period1 = T_1 , Period2 = T_2 , and so on. As shown in Figure 7-206, the CEVT1 event is a good trigger point to read the timing data, T_1 , T_2 , T_3 , T_4 are all valid here.

ADVANCE INFORMATION

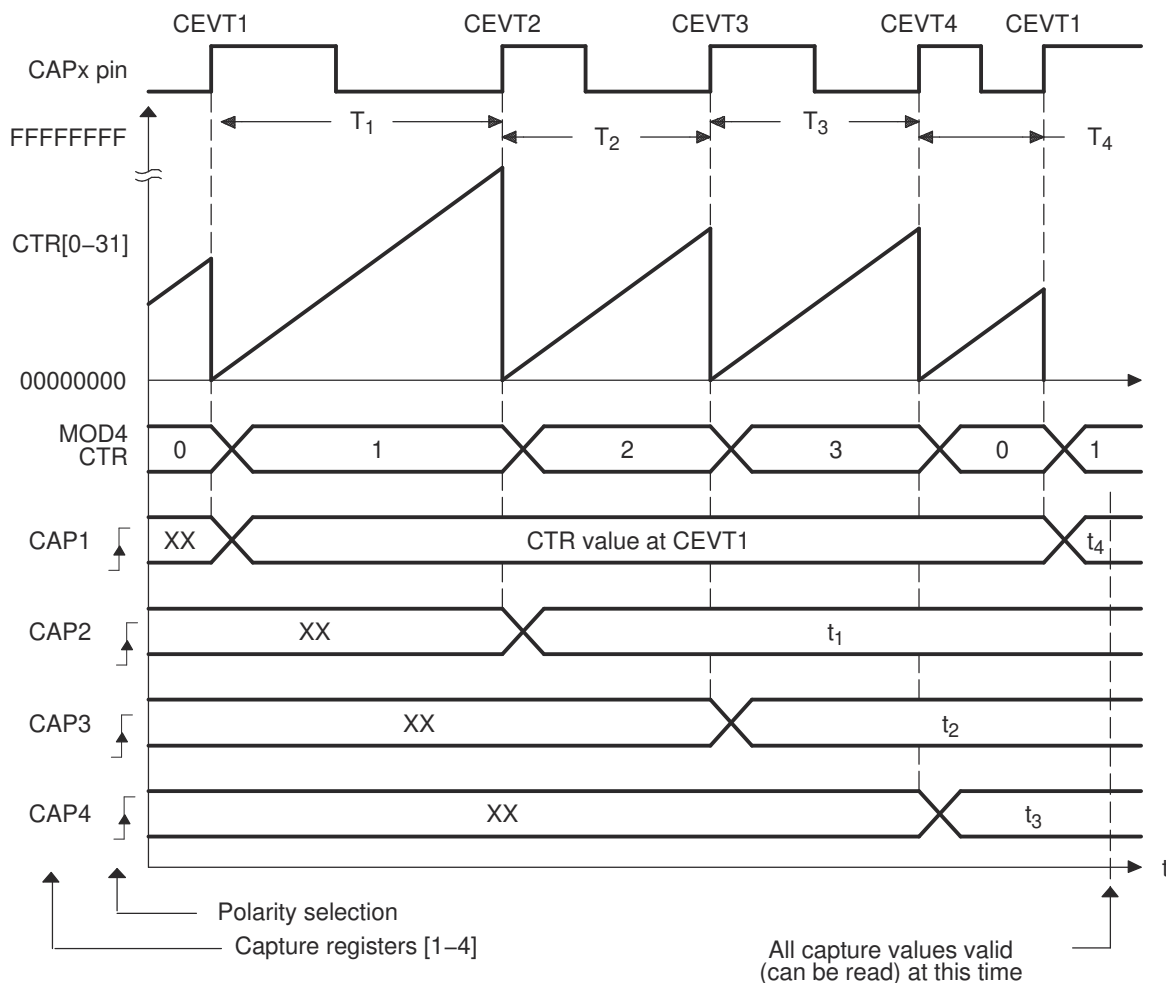

Figure 7-206. Capture Sequence for Delta Mode Time-stamp and Rising Edge Detect

7.4.6.7.4 Example 4 - Time Difference (Delta) Operation Rising and Falling Edge Trigger

In Figure 7-207, the eCAP operating mode is almost the same as in previous section except Capture events are qualified as either Rising or Falling edge, this now gives both Period and Duty cycle information, that is: Period1 = T_1+T_2 , Period2 = T_3+T_4 , and so on. Duty Cycle1 (on-time %) = $T_1 / \text{Period1} \times 100\%$, Duty Cycle1 (off-time %) = $T_2 / \text{Period1} \times 100\%$, and so on.

During initialization, you must write to the active registers for both period and compare. This action will automatically copy the init values into the shadow values. For subsequent compare updates during run-time, the shadow registers must be used.

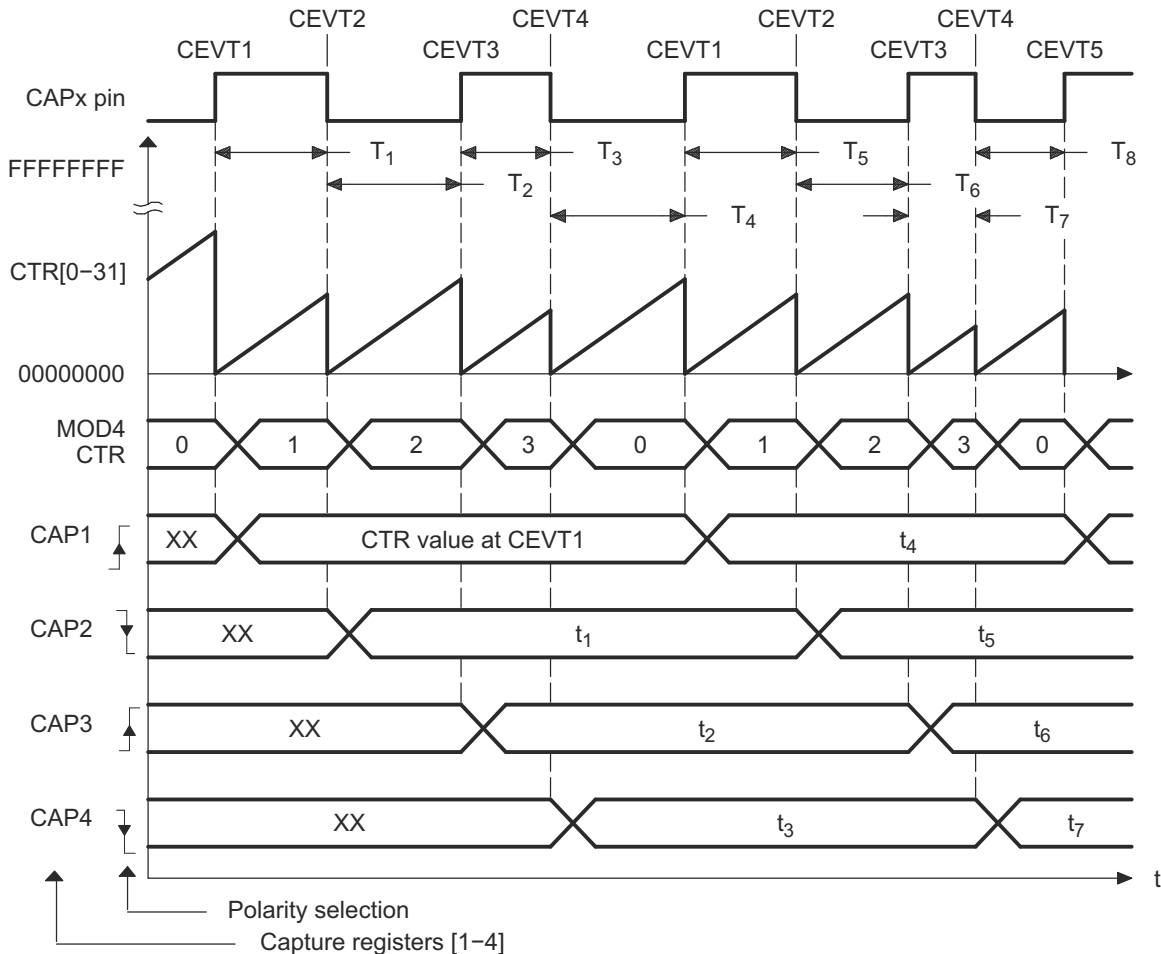

Figure 7-207. Capture Sequence for Delta Mode Time-stamp With Rising and Falling Edge Detect

ADVANCE INFORMATION

7.4.6.8 Application of the APWM Mode

In this example, the eCAP module is configured to operate as a PWM generator. Here, a very simple single-channel PWM waveform is generated from the APWMx output pin. The PWM polarity is active high, which means that the compare value (CAP2 reg is now a compare register) represents the on-time (high level) of the period. Alternatively, if the APWMPOL bit is configured for active low, then the compare value represents the off-time.

7.4.6.8.1 Example 1 - Simple PWM Generation (Independent Channel/s)

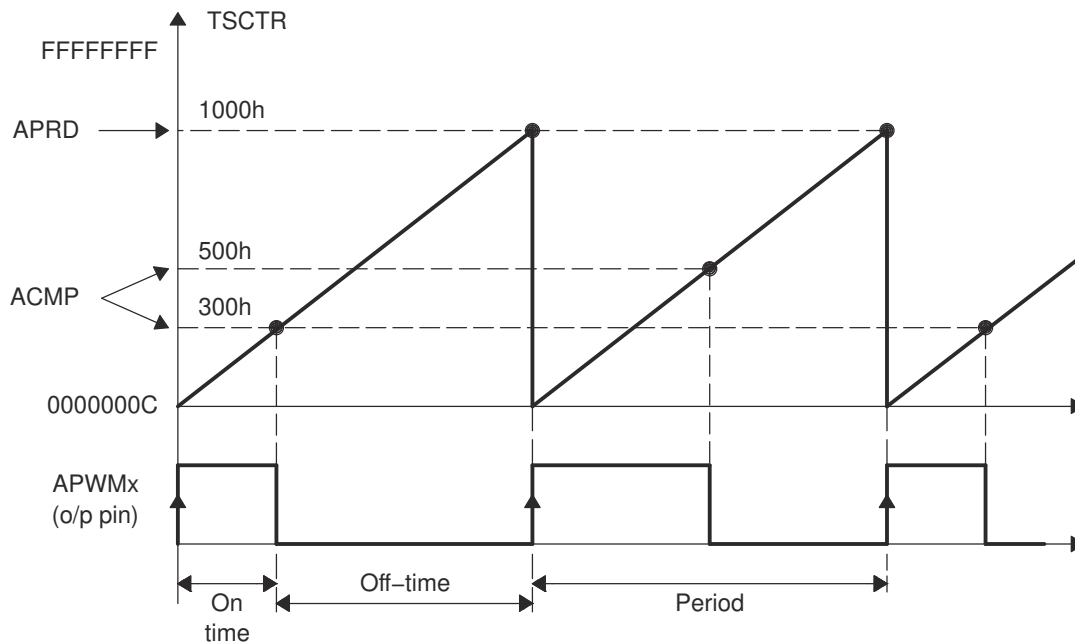

Figure 7-208. PWM Waveform Details of APWM Mode Operation

ADVANCE INFORMATION

7.4.7 Enhanced Quadrature Encoder Pulse (eQEP)

The enhanced Quadrature Encoder Pulse (eQEP) module described here is a eQEP.

The enhanced quadrature encoder pulse (eQEP) module is used for direct interface with a linear or rotary incremental encoder to get position, direction, and speed information from a rotating machine for use in a high-performance motion and position-control system.

7.4.7.1 Introduction.....	608
7.4.7.2 Configuring Device Pins.....	610
7.4.7.3 EQEP Integration.....	611
7.4.7.4 Description.....	612
7.4.7.5 Quadrature Decoder Unit (QDU).....	618
7.4.7.6 Position Counter and Control Unit (PCCU).....	621
7.4.7.7 eQEP Edge Capture Unit.....	628
7.4.7.8 eQEP Watchdog.....	632
7.4.7.9 eQEP Unit Timer Base.....	632
7.4.7.10 eQEP Interrupt Structure.....	633

7.4.7.1 Introduction

An incremental encoder disk is patterned with a track of slots along its periphery, as shown in Figure 7-209. These slots create an alternating pattern of dark and light lines. The disk count is defined as the number of dark and light line pairs that occur per revolution (lines per revolution). As a rule, a second track is added to generate a signal that occurs once per revolution (index signal: QEPI), which can be used to indicate an absolute position. Encoder manufacturers identify the index pulse using different terms such as index, marker, home position, and zero reference

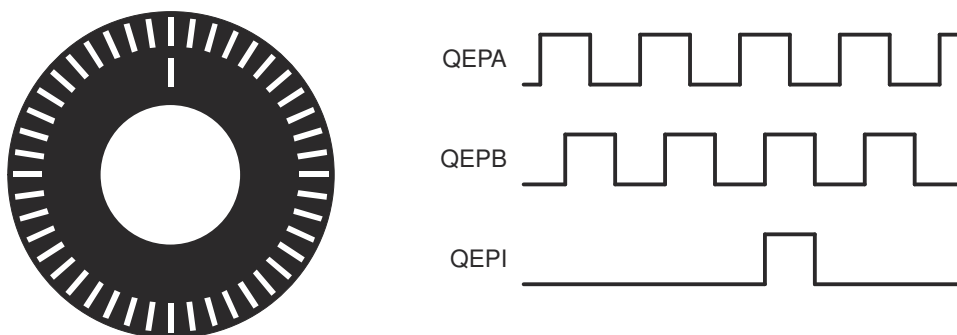
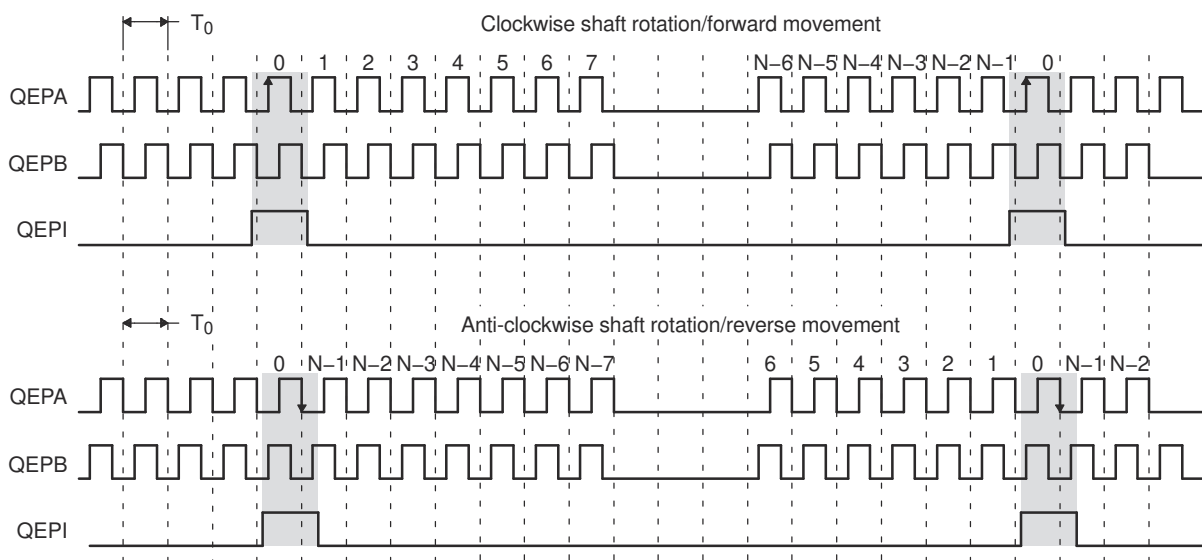

Figure 7-209. Optical Encoder Disk

To derive direction information, the lines on the disk are read out by two different photo-elements that "look" at the disk pattern with a mechanical shift of 1/4 the pitch of a line pair between them. This shift is detected with a reticle or mask that restricts the view of the photo-element to the desired part of the disk lines. As the disk rotates, the two photo-elements generate signals that are shifted 90° out of phase from each other. These are commonly called the quadrature QEPA and QEPB signals. The clockwise direction for most encoders is defined as the QEPA channel going positive before the QEPB channel and conversely, as shown in Figure 7-210.



Legend: N = lines per revolution

Figure 7-210. QEP Encoder Output Signal for Forward/Reverse Movement

The encoder wheel typically makes one revolution for every revolution of the motor, or the wheel may be at a geared rotation ratio with respect to the motor. Therefore, the frequency of the digital signal coming from the QEPA and QEPB outputs varies proportionally with the velocity of the motor. For example, a 2000-line encoder directly coupled to a motor running at 5000 revolutions per minute (rpm) results in a frequency of 166.6 kHz, so

by measuring the frequency of either the QEPA or QEPB output, the processor can determine the velocity of the motor.

Quadrature encoders from different manufacturers come with two forms of index pulse (gated index pulse or ungated index pulse) as shown in Figure 7-211. A nonstandard form of index pulse is ungated. In the ungated configuration, the index edges are not necessarily coincident with A and B signals. The gated index pulse is aligned to any of the four quadrature edges and width of the index pulse and can be equal to a quarter, half, or full period of the quadrature signal.

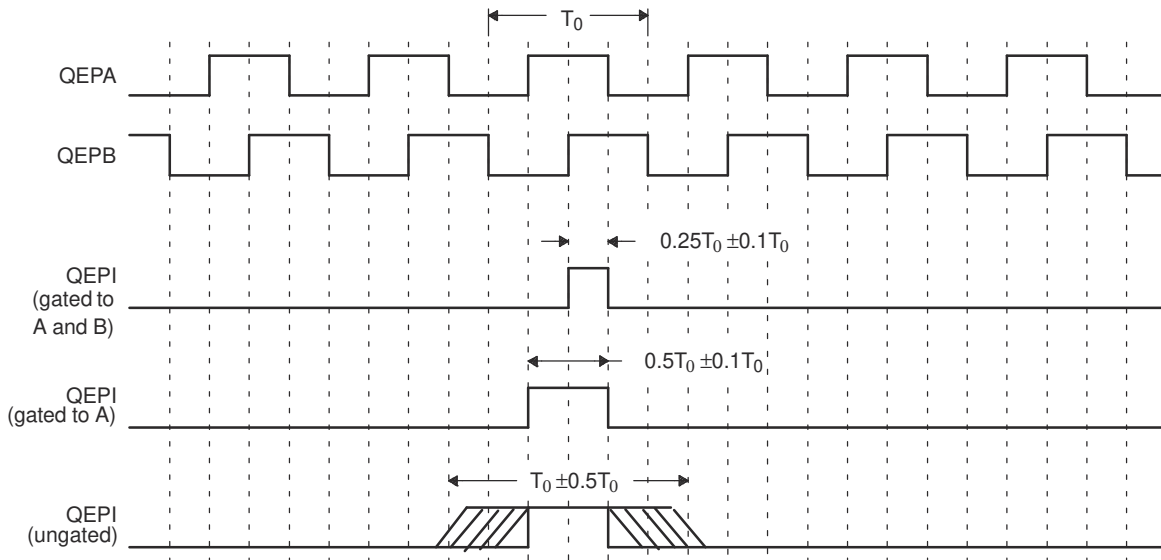

Figure 7-211. Index Pulse Example

Some typical applications of shaft encoders include robotics and computer input in the form of a mouse. Inside your mouse you can see where the mouse ball spins a pair of axles (a left/right, and an up/down axle). These axles are connected to optical shaft encoders that effectively tell the computer how fast and in what direction the mouse is moving.

General Issues: Estimating velocity from a digital position sensor is a cost-effective strategy in motor control. Two different first order approximations for velocity may be written as:

$$v(k) \approx \frac{x(k) - x(k - 1)}{T} = \frac{\Delta X}{T} \tag{11}$$

$$v(k) \approx \frac{X}{t(k) - t(k - 1)} = \frac{X}{\Delta T} \tag{12}$$

where:

- $v(k)$ = Velocity at time instant k
- $x(k)$ = Position at time instant k
- $x(k-1)$ = Position at time instant $k-1$
- T = Fixed unit time or inverse of velocity calculation rate
- ΔX = Incremental position movement in unit time
- $t(k)$ = Time instant " k "
- $t(k-1)$ = Time instant " $k-1$ "
- X = Fixed unit position
- ΔT = Incremental time elapsed for unit position movement

Equation 11 is the conventional approach to velocity estimation and it requires a time base to provide a unit time event for velocity calculation. Unit time is basically the inverse of the velocity calculation rate.

The encoder count (position) is read once during each unit time event. The quantity $[x(k) - x(k-1)]$ is formed by subtracting the previous reading from the current reading. Then the velocity estimate is computed by multiplying by the known constant $1/T$ (where T is the constant time between unit time events and is known in advance).

Estimation based on [Equation 11](#) has an inherent accuracy limit directly related to the resolution of the position sensor and the unit time period T . For example, consider a 500-line per revolution quadrature encoder with a velocity calculation rate of 400 Hz. When used for position, the quadrature encoder gives a four-fold increase in resolution; in this case, 2000 counts per revolution. The minimum rotation that can be detected is therefore 0.0005 revolutions, which gives a velocity resolution of 12 rpm when sampled at 400 Hz. While this resolution may be satisfactory at moderate or high speeds, for example 1% error at 1200 rpm, it would clearly prove inadequate at low speeds. In fact, at speeds below 12 rpm, the speed estimate would erroneously be zero much of the time.

At low speed, [Equation 12](#) provides a more accurate approach. It requires a position sensor that outputs a fixed interval pulse train, such as the aforementioned quadrature encoder. The width of each pulse is defined by motor speed for a given sensor resolution. [Equation 12](#) can be used to calculate motor speed by measuring the elapsed time between successive quadrature pulse edges. However, this method suffers from the opposite limitation, as does [Equation 11](#). A combination of relatively large motor speeds and high sensor resolution makes the time interval ΔT small, and thus more greatly influenced by the timer resolution. This can introduce considerable error into high-speed estimates.

For systems with a large speed range (that is, speed estimation is needed at both low and high speeds), one approach is to use [Equation 12](#) at low speed and have the DSP software switch over to [Equation 11](#) when the motor speed rises above some specified threshold.

7.4.7.2 Configuring Device Pins

The GPIO mux registers must be configured to connect this peripheral to the device pins.

For proper operation of the eQEP module, input GPIO pins must be configured via the GPxQSELn registers for synchronous input mode (with or without qualification). The asynchronous mode should not be used for eQEP input pins. The internal pullups can be configured in the GPyPUD register.

See the *GPIO* chapter for more details on GPIO mux and settings.

7.4.7.3 EQEP Integration

There are 3x EQEP modules integrated in the device. The diagram below provides a visual representation of the device integration details.

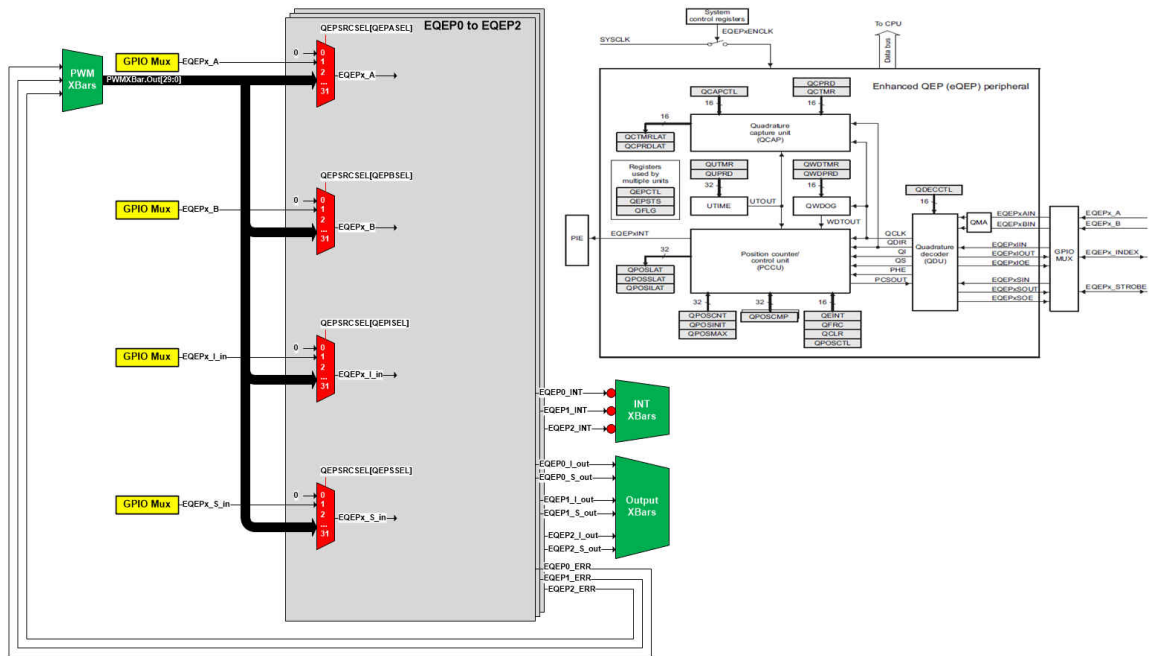

Figure 7-212. EQEP Integration Diagram

7.4.7.4 Description

This section provides the eQEP inputs, memory map, and functional description.

7.4.7.4.1 EQEP Inputs

The eQEP inputs include two pins for quadrature-clock mode or direction-count mode, an index (or 0 marker), and a strobe input. The eQEP module requires that the QEPA, QEPB, and QEPI inputs are synchronized to SYSCLK prior to entering the module. The application code should enable the synchronous GPIO input feature on any eQEP-enabled GPIO pins (see the chapter for more details).

- **QEPA/XCLK and QEPB/XDIR**

These two pins can be used in quadrature-clock mode or direction-count mode.

- Quadrature-clock Mode

The eQEP encoders provide two square wave signals (A and B) 90 electrical degrees out of phase.

This phase relationship is used to determine the direction of rotation of the input shaft and number of eQEP pulses from the index position to derive the relative position information. For forward or clockwise rotation, QEPA signal leads QEPB signal and conversely. The quadrature decoder uses these two inputs to generate quadrature-clock and direction signals.

- Direction-count Mode

In direction-count mode, direction and clock signals are provided directly from the external source. Some position encoders have this type of output instead of quadrature output. The QEPA pin provides the clock input and the QEPB pin provides the direction input.

- **QEPI: Index or Zero Marker**

The eQEP encoder uses an index signal to assign an absolute start position from which position information is incrementally encoded using quadrature pulses. This pin is connected to the index output of the eQEP encoder to optionally reset the position counter for each revolution. This signal can be used to initialize or latch the position counter on the occurrence of a desired event on the index pin.

- **QEPS: Strobe Input**

This general-purpose strobe signal can initialize or latch the position counter on the occurrence of a desired event on the strobe pin. This signal is typically connected to a sensor or limit switch to notify that the motor has reached a defined position.

Input signals to the eQEP (QEPA, QEPB, QEPI and QEPS) can come from multiple sources; that is, device pin, CMPSSx, or PWMXBARx. One typical used case is if SinCos transducers are used in the motor control system to estimate the position of motor shaft and Index signal is coming from traditional rotary encoder, source of the eQEP signals (QEPA, QEPB and QEPI) can be configured as output of CMPSSx which decodes the Sin, Cos and Index signals. [Figure 7-213](#) illustrates the use case.

Selection of the source of Input signals (QEPA, QEPB, and QEPI) is user-configurable through the QEPSRCSEL register as shown in .

Table 7-128. eQEP Input Source Select Table

QEPSRCSEL. QEPASEL	Source for QEPA	QEPSRCSEL. QEPBSEL	Source for QEPB
0	Tie-low	0	Tie-low
1	EQEP_A_PAD	1	EQEP_B_PAD
2	PWMXBAR.OUT0	2	PWMXBAR.OUT0
3	PWMXBAR.OUT1	3	PWMXBAR.OUT1
4	PWMXBAR.OUT2	4	PWMXBAR.OUT2
5	PWMXBAR.OUT3	5	PWMXBAR.OUT3
6	PWMXBAR.OUT4	6	PWMXBAR.OUT4
7	PWMXBAR.OUT5	7	PWMXBAR.OUT5
8	PWMXBAR.OUT6	8	PWMXBAR.OUT6
9	PWMXBAR.OUT7	9	PWMXBAR.OUT7
10	PWMXBAR.OUT8	10	PWMXBAR.OUT8
11	PWMXBAR.OUT9	11	PWMXBAR.OUT9
12	PWMXBAR.OUT10	12	PWMXBAR.OUT10
13	PWMXBAR.OUT11	13	PWMXBAR.OUT11
14	PWMXBAR.OUT12	14	PWMXBAR.OUT12
15	PWMXBAR.OUT13	15	PWMXBAR.OUT13
16	PWMXBAR.OUT14	16	PWMXBAR.OUT14
17	PWMXBAR.OUT15	17	PWMXBAR.OUT15
18	PWMXBAR.OUT16	18	PWMXBAR.OUT16
19	PWMXBAR.OUT7	19	PWMXBAR.OUT7
20	PWMXBAR.OUT18	20	PWMXBAR.OUT18
21	PWMXBAR.OUT19	21	PWMXBAR.OUT19
22	PWMXBAR.OUT20	22	PWMXBAR.OUT20
23	PWMXBAR.OUT21	23	PWMXBAR.OUT21
24	PWMXBAR.OUT22	24	PWMXBAR.OUT22
25	PWMXBAR.OUT23	25	PWMXBAR.OUT23
26	PWMXBAR.OUT24	26	PWMXBAR.OUT24
27	PWMXBAR.OUT25	27	PWMXBAR.OUT25
28	PWMXBAR.OUT26	28	PWMXBAR.OUT26
29	PWMXBAR.OUT27	29	PWMXBAR.OUT27
30	PWMXBAR.OUT28	30	PWMXBAR.OUT28
31	PWMXBAR.OUT29	31	PWMXBAR.OUT29

Note

Configuration of QEPSRCSEL register to select the source of QEPA, QEPB, and QEPI signals can lead to unexpected transition on these signals, which can cause an undesirable outcome if eQEP is already running. You need to make sure that the eQEP is disabled before configuring the QEPSRCSEL register for input signals.

7.4.7.4.2 Functional Description

The eQEP peripheral contains the following major functional units (as shown in [Figure 7-214](#)):

- Programmable input qualification for each pin (part of the GPIO MUX)
- Quadrature decoder unit (QDU)
- Position counter and control unit for position measurement (PCCU)
- Quadrature edge-capture unit for low-speed measurement (QCAP)
- Unit time base for speed/frequency measurement (UTIME)
- Watchdog timer for detecting stalls (QWDOG)

Figure 7-214. Functional Block Diagram of the eQEP Peripheral

7.4.7.4.3 eQEP Memory Map

lists the registers with their memory locations, sizes, and reset values.

7.4.7.5 Quadrature Decoder Unit (QDU)

Figure 7-215 shows a functional block diagram of the QDU.

ADVANCE INFORMATION

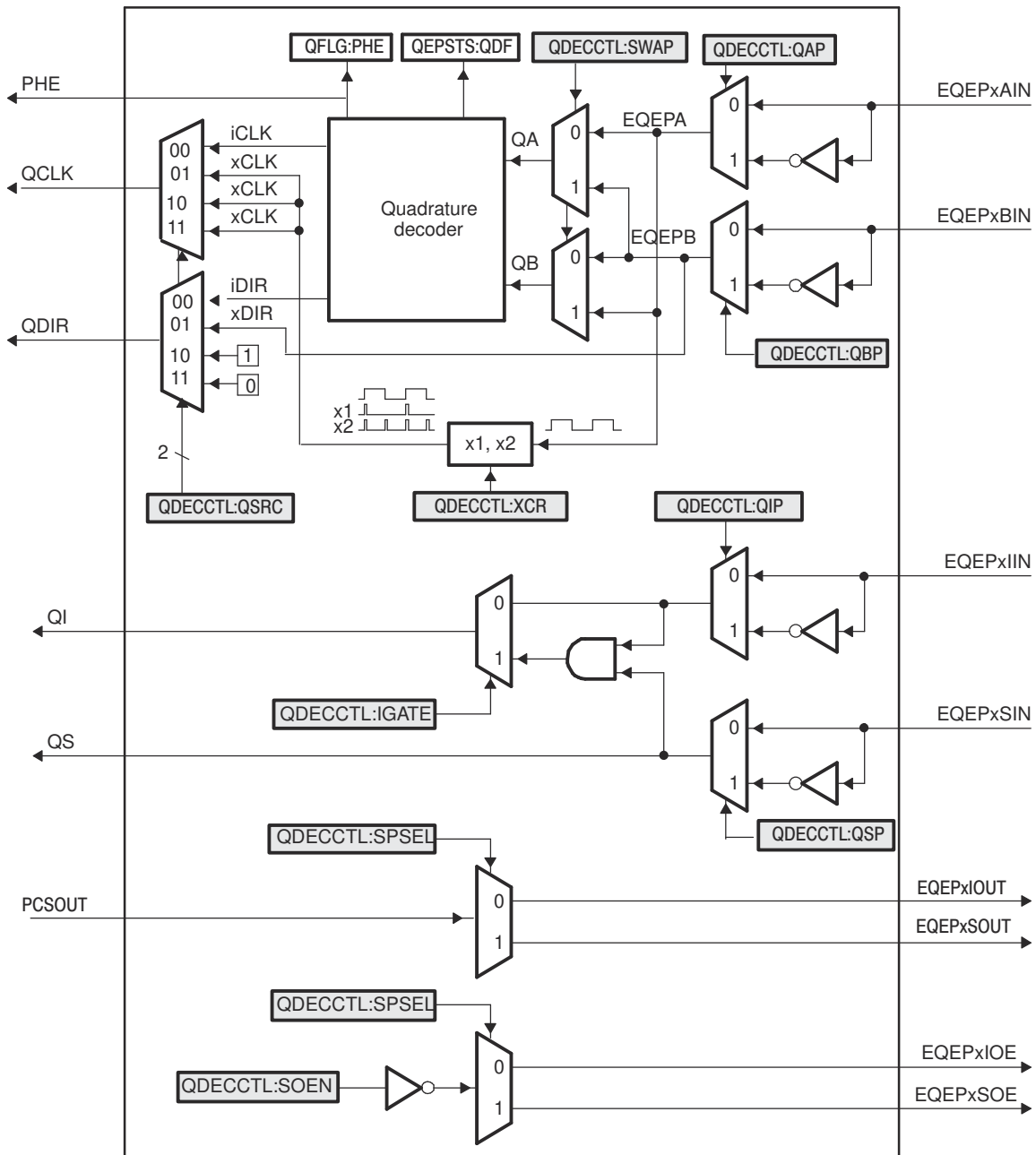

Figure 7-215. Functional Block Diagram of Decoder Unit

7.4.7.5.1 Position Counter Input Modes

Clock and direction input to the position counter is selected using QDECCTL[QSRC] bits, based on interface input requirement as follows:

- Quadrature-count mode
- Direction-count mode
- UP-count mode
- DOWN-count mode

7.4.7.5.1.1 Quadrature Count Mode

The quadrature decoder generates the direction and clock to the position counter in quadrature count mode.

Direction Decoding The direction decoding logic of the eQEP circuit determines which one of the sequences (QEPA, QEPB) is the leading sequence and accordingly updates the direction information in the QEPSTS[QDF] bit. Table 7-129 and Figure 7-216 show the direction decoding logic in truth table and state machine form. Both edges of the QEPA and QEPB signals are sensed to generate count pulses for the position counter. Therefore, the frequency of the clock generated by the eQEP logic is four times that of each input sequence. Figure 7-217 shows the direction decoding and clock generation from the eQEP input signals.

Table 7-129. Quadrature Decoder Truth Table

Previous Edge	Present Edge	QDIR	QPOSCNT
QA↑	QB↑	UP	Increment
	QB↓	DOWN	Decrement
	QA↓	TOGGLE	Increment or Decrement
QA↓	QB↓	UP	Increment
	QB↑	DOWN	Decrement
	QA↑	TOGGLE	Increment or Decrement
QB↑	QA↑	DOWN	Decrement
	QA↓	UP	Increment
	QB↓	TOGGLE	Increment or Decrement
QB↓	QA↓	DOWN	Decrement
	QA↑	UP	Increment
	QB↑	TOGGLE	Increment or Decrement

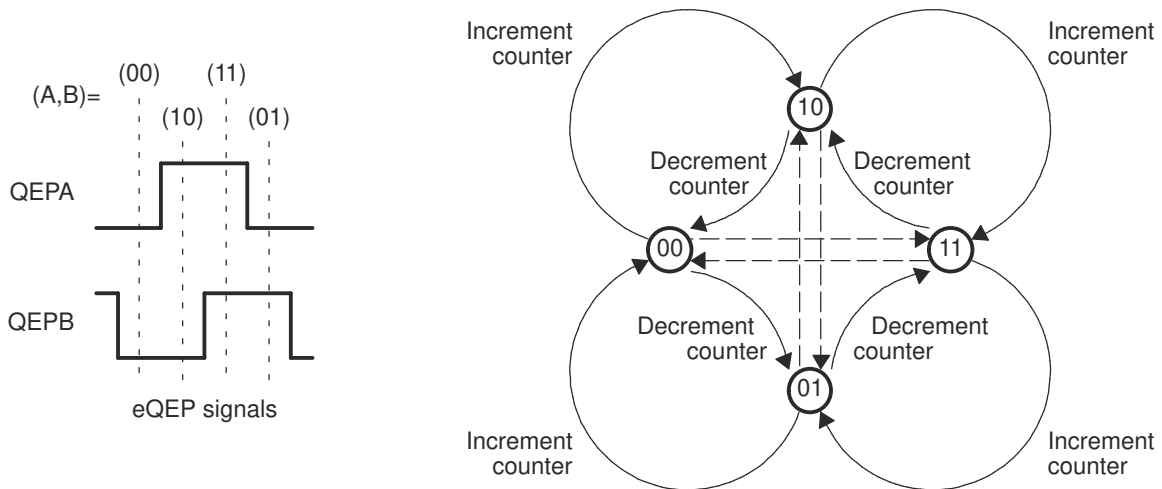

Figure 7-216. Quadrature Decoder State Machine

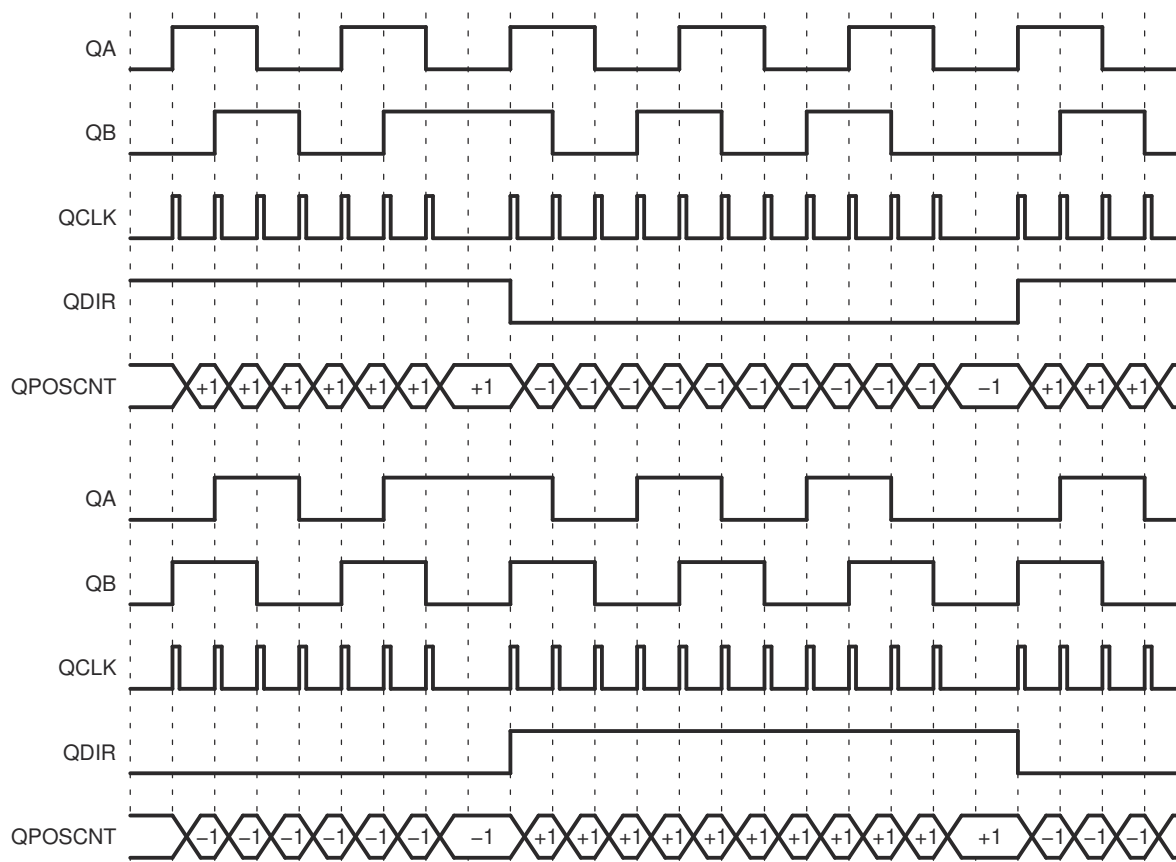

Figure 7-217. Quadrature-clock and Direction Decoding

Phase Error Flag In normal operating conditions, quadrature inputs QEPA and QEPB is 90 degrees out of phase. The phase error flag (PHE) is set in the QFLG register and the QPOSCNT value can be incorrect and offset by multiples of 1 or 3. That is, when edge transition is detected simultaneously on the QEPA and QEPB signals to optionally generate interrupts. State transitions marked by dashed lines in Figure 7-216 are invalid transitions that generate a phase error.

Count Multiplication The eQEP position counter provides 4x times the resolution of an input clock by generating a quadrature-clock (QCLK) on the rising/falling edges of both eQEP input clocks (QEPA and QEPB) as shown in Figure 7-217.

Reverse Count In normal quadrature count operation, QEPA input is applied to the QA input of the quadrature decoder and the QEPB input is applied to the QB input of the quadrature decoder. Reverse counting is enabled by setting the SWAP bit in the QDECCTL register. This swaps the input to the quadrature decoder; thereby, reversing the counting direction.

7.4.7.5.1.2 Direction-Count Mode

Some position encoders provide direction and clock outputs, instead of quadrature outputs. In such cases, direction-count mode can be used. QEPA input will provide the clock for the position counter and the QEPB input will have the direction information. The position counter is incremented on every rising edge of a QEPA input when the direction input is high, and decremented when the direction input is low.

7.4.7.5.1.3 Up-Count Mode

The counter direction signal is hard-wired for up-count and the position counter is used to measure the frequency of the QEPA input. Clearing the QDECCTL[XCR] bit enables clock generation to the position counter on both edges of the QEPA input; thereby, increasing the measurement resolution by a factor of 2x. In up-count mode, we recommend that the application not configure QEPB as a GPIO mux option, or make sure that a signal edge is not generated on the QEPB input.

7.4.7.5.1.4 Down-Count Mode

The counter direction signal is hardwired for a down-count and the position counter is used to measure the frequency of the QEPA input. Clearing the QDECCTL[XCR] bit enables clock generation to the position counter on both edges of a QEPA input, thereby increasing the measurement resolution by a factor of 2x. In down-count mode, it is recommended that the application not configure QEPB as a GPIO mux option, or ensure that a signal edge is not generated on the QEPB input.

7.4.7.5.2 eQEP Input Polarity Selection

Each eQEP input can be inverted using QDECCTL[8:5] control bits. As an example, setting the QDECCTL[QIP] bit will invert the index input.

7.4.7.5.3 Position-Compare Sync Output

The enhanced eQEP peripheral includes a position-compare unit that is used to generate the position-compare sync signal on compare match between the position-counter register (QPOSCNT) and the position-compare register (QPOSCMP). This sync signal can be output using an index pin or strobe pin of the EQEP peripheral.

Setting the QDECCTL[SOEN] bit enables the position-compare sync output and the QDECCTL[SPSEL] bit selects either an eQEP index pin or an eQEP strobe pin.

7.4.7.6 Position Counter and Control Unit (PCCU)

The position-counter and control unit provides two configuration registers (QEPCTL and QPOSCTL) for setting up position-counter operational modes, position-counter initialization/latch modes and position-compare logic for sync signal generation.

7.4.7.6.1 Position Counter Operating Modes

Position-counter data may be captured in different manners. In some systems, the position counter is accumulated continuously for multiple revolutions and the position-counter value provides the position information with respect to the known reference. An example of this is the quadrature encoder mounted on the motor controlling the print head in the printer. Here the position counter is reset by moving the print head to the home position and then the position counter provides absolute position information with respect to home position.

In other systems, the position counter is reset on every revolution using index pulse, and the position counter provides a rotor angle with respect to the index pulse position.

The position counter can be configured to operate in following four modes

- Position-Counter Reset on Index Event
- Position-Counter Reset on Maximum Position
- Position-Counter Reset on the first Index Event
- Position-Counter Reset on Unit Time Out Event (Frequency Measurement)

In all the above operating modes, the position counter is reset to 0 on overflow and to the QPOSMAX register value on underflow. Overflow occurs when the position counter counts up after the QPOSMAX value. Underflow occurs when the position counter counts down after "0". The Interrupt flag is set to indicate overflow/underflow in QFLG register.

7.4.7.6.1.1 Position Counter Reset on Index Event (QEPCTL[PCRM]=00)

If the index event occurs during the forward movement, then the position counter is reset to 0 on the next eQEP clock. If the index event occurs during the reverse movement, then the position counter is reset to the value in the QPOS MAX register on the next eQEP clock.

First index marker is defined as the quadrature edge following the first index edge. The eQEP peripheral records the occurrence of the first index marker (QEPSTS[FIMF]) and direction on the first index event marker (QEPSTS[FIDF]) in QEPSTS registers, it also remembers the quadrature edge on the first index marker so that same relative quadrature transition is used for index event reset operation.

For example, if the first reset operation occurs on the falling edge of QEPB during the forward direction, then all the subsequent reset must be aligned with the falling edge of QEPB for the forward rotation and on the rising edge of QEPB for the reverse rotation as shown in Figure 7-218.

The position-counter value is latched to the QPOSILAT register and direction information is recorded in the QEPSTS[QDLF] bit on every index event marker. The position-counter error flag (QEPSTS[PCEF]) and error interrupt flag (QLFG[PCE]) are set if the latched value is not equal to 0 or QPOS MAX. The position-counter error flag (QEPSTS[PCEF]) is updated on every index event marker and an interrupt flag (QLFG[PCE]) will be set on error that can be cleared only through software.

The index event latch configuration QEPCTL[IEL] must be configured to '00' or '11' when pcrm=0 and the position counter error flag/interrupt flag are generated only in index event reset mode. The position counter value is latched into the IPOS LAT register on every index marker.

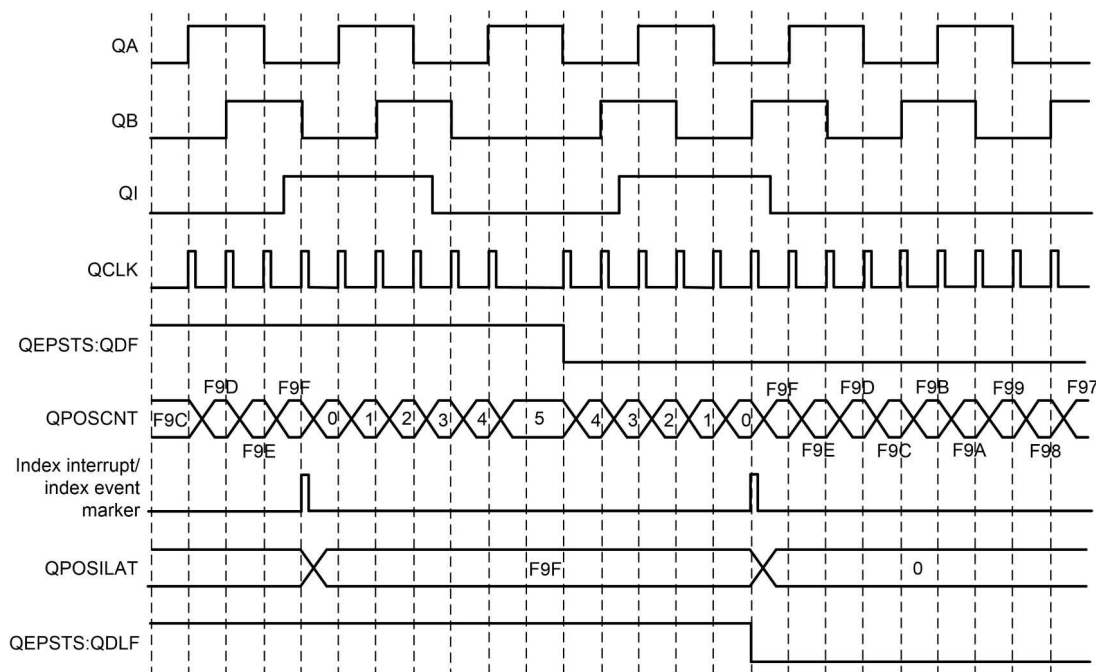

Figure 7-218. Position Counter Reset by Index Pulse for 1000 Line Encoder (QPOS MAX = 3999 or 0xF9F)

Note

In case of a boundary condition where the time period between the Index Event and the previous QCLK edge is less than SYSCLK period, then QPOSCNT gets reset to zero or QPOS MAX in the same SYSCLK cycle and does not wait for the next QCLK edge to occur.

7.4.7.6.1.2 Position Counter Reset on Maximum Position (QEPCTL[PCRM]=01)

If the position counter is equal to QPOSMAX, then the position counter is reset to 0 on the next eQEP clock for forward movement and position counter overflow flag is set. If the position counter is equal to ZERO, then the position counter is reset to QPOSMAX on the next QEP clock for reverse movement and position-counter underflow flag is set. Figure 7-219 shows the position-counter reset operation in this mode.

The first index marker fields (QEPSTS[FIDF] and QEPSTS[FIMF]) are not applicable in this mode.

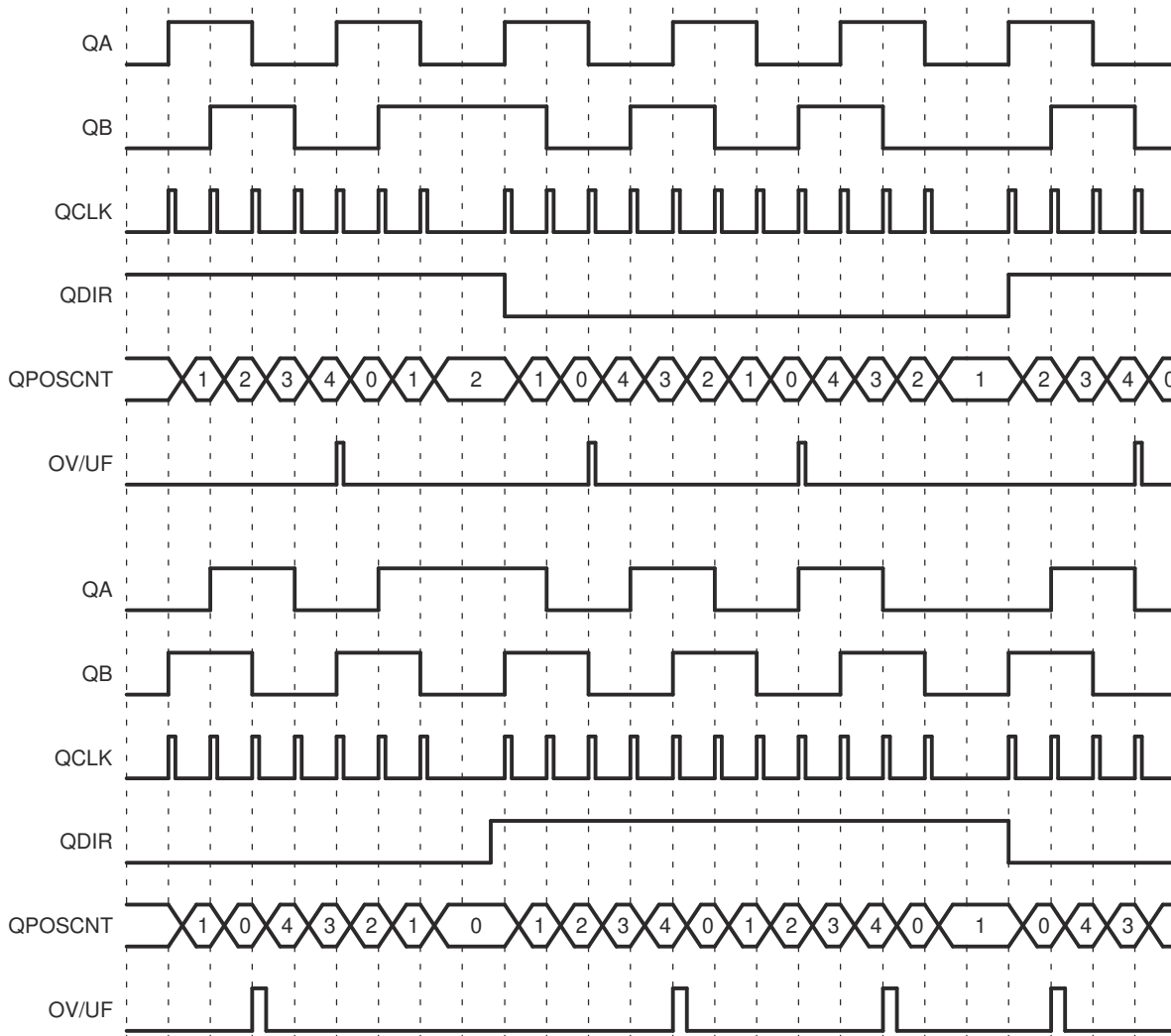

Figure 7-219. Position Counter Underflow/Overflow (QPOSMAX = 4)

7.4.7.6.1.3 Position Counter Reset on the First Index Event (QEPCTL[PCRM] = 10)

If the index event occurs during forward movement, then the position counter is reset to 0 on the next eQEP clock. If the index event occurs during the reverse movement, then the position counter is reset to the value in the QPOSMAX register on the next eQEP clock. Note that this is done only on the first occurrence and subsequently the position-counter value is not reset on an index event; rather, it is reset based on maximum position as described in Section 7.4.7.6.1.2.

The first index marker fields (QEPSTS[FIDF] and QEPSTS[FIMF]) are not applicable in this mode.

7.4.7.6.1.4 Position Counter Reset on Unit Time out Event (QEPCTL[PCRM] = 11)

7.4.7.6.2 Position Counter Latch

The eQEP index and strobe input can be configured to latch the position counter (QPOSCNT) into QPOSILAT and QPOSSLAT, respectively, on occurrence of a definite event on these pins.

7.4.7.6.2.1 Index Event Latch

In some applications, it is not desirable to reset the position counter on every index event and instead it can be required to operate the position counter in full 32-bit mode (QEPCTL[PCRM] = 01 and QEPCTL[PCRM] = 10 modes).

In such cases, the eQEP position counter can be configured to latch on the following events and direction information is recorded in the QEPSTS[QDLF] bit on every index event marker.

- Latch on Rising edge (QEPCTL[IEL]=01)
- Latch on Falling edge (QEPCTL[IEL]=10)
- Latch on Index Event Marker (QEPCTL[IEL]=11)

This is particularly useful as an error checking mechanism to check if the position counter accumulated the correct number of counts between index events. As an example, the 1000-line encoder must count 4000 times when moving in the same direction between the index events.

The index event latch interrupt flag (QFLG[IEL]) is set when the position counter is latched to the QPOSILAT register. The index event latch configuration bits (QEPCTZ[IEL]) are ignored when QEPCTL[PCRM] = 00.

Latch on Rising Edge (QEPCTL[IEL]=01)	The position-counter value (QPOSCNT) is latched to the QPOSILAT register on every rising edge of an index input.
Latch on Falling Edge (QEPCTL[IEL] = 10)	The position-counter value (QPOSCNT) is latched to the QPOSILAT register on every falling edge of index input.
Latch on Index Event Marker/Software Index Marker (QEPCTL[IEL] = 11)	The first index marker is defined as the quadrature edge following the first index edge. The eQEP peripheral records the occurrence of the first index marker (QEPSTS[FIMF]) and the direction on the first index event marker (QEPSTS[FIDF]) in the QEPSTS registers. The eQEP peripheral also remembers the quadrature edge on the first index marker so that the same relative quadrature transition is used for latching the position counter (QEPCTL[IEL]=11).

Figure 7-220 shows the position counter latch using an index event marker.

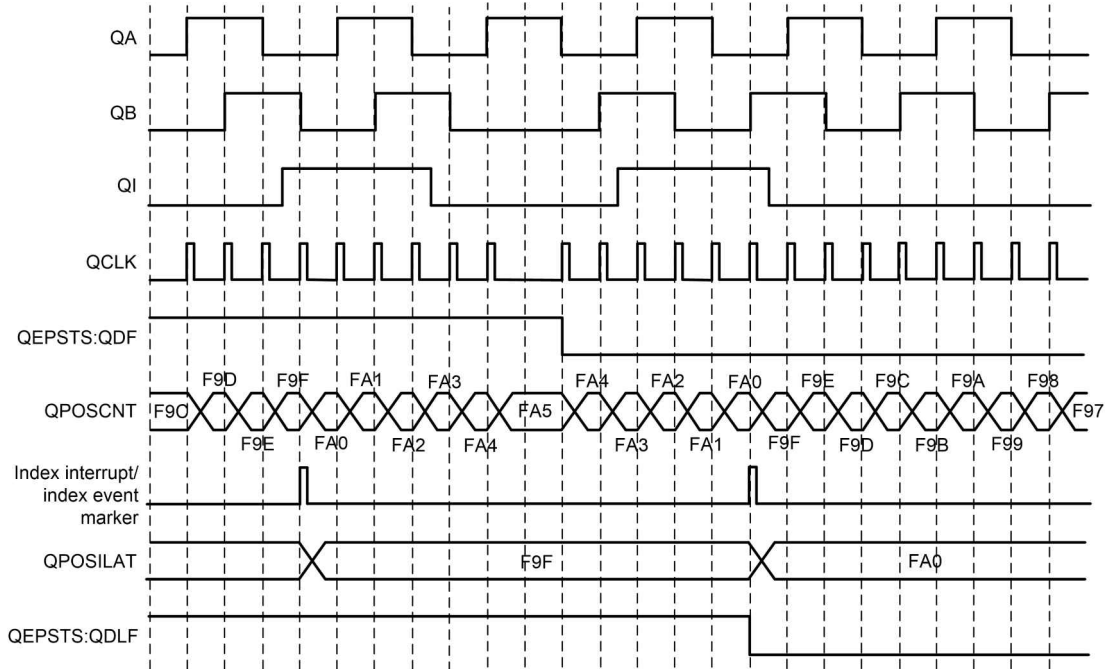

Figure 7-220. Software Index Marker for 1000-line Encoder (QEPCTL[IEL] = 1)

7.4.7.6.2.2 Strobe Event Latch

The position-counter value is latched to the QPOSSLAT register on the rising edge of the strobe input by clearing the QEPCTL[SEL] bit.

If the QEPCTL[SEL] bit is set, then the position-counter value is latched to the QPOSSLAT register on the rising edge of the strobe input for forward direction, and on the falling edge of the strobe input for reverse direction as shown in Figure 7-221.

The strobe event latch interrupt flag (QFLG[SEL]) is set when the position counter is latched to the QPOSSLAT register.

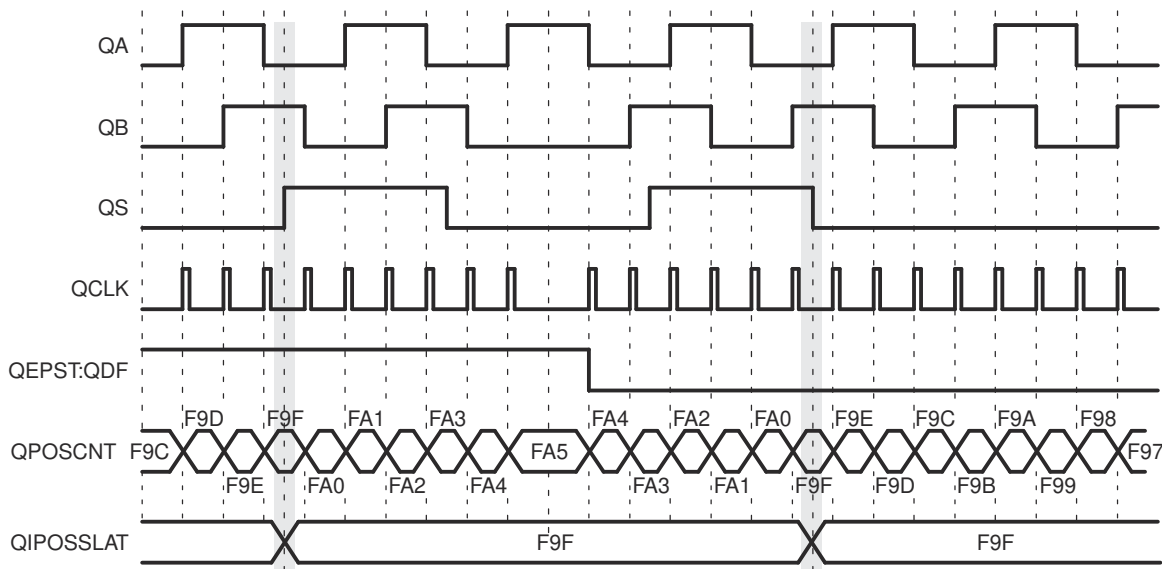

Figure 7-221. Strobe Event Latch (QEPCTL[SEL] = 1)

7.4.7.6.3 Position Counter Initialization

The position counter can be initialized using the following events:

- Index event
- Strobe event
- Software initialization

Index Event Initialization (IEI) The QEPI index input can be used to trigger the initialization of the position counter at the rising or falling edge of the index input. If the QEPCTL[IEI] bits are 10, then the position counter (QPOSCNT) is initialized with a value in the QPOSINIT register on the rising edge of index input. Conversely, if the QEPCTL[IEI] bits are 11, initialization is on the falling edge of the index input.

Strobe Event Initialization (SEI) If the QEPCTL[SEI] bits are 10, then the position counter is initialized with a value in the QPOSINIT register on the rising edge of strobe input. If QEPCTL[SEL] bits are 11, then the position counter is initialized with a value in the QPOSINIT register on the rising edge of strobe input for forward direction and on the falling edge of strobe input for reverse direction.

Software Initialization (SWI) The position counter can be initialized in software by writing a 1 to the QEPCTL[SWI] bit. This bit is not automatically cleared. While the bit is still set, if a 1 is written to the bit again, the position counter is re-initialized.

7.4.7.6.4 eQEP Position-compare Unit

The eQEP peripheral includes a position-compare unit that is used to generate a sync output and/or interrupt on a position-compare match. Figure 7-222 shows a diagram. The position-compare (QPOSCMP) register is shadowed and shadow mode can be enabled or disabled using the QPOSCTL[PSSHDW] bit. If the shadow mode is not enabled, the CPU writes directly to the active position compare register.

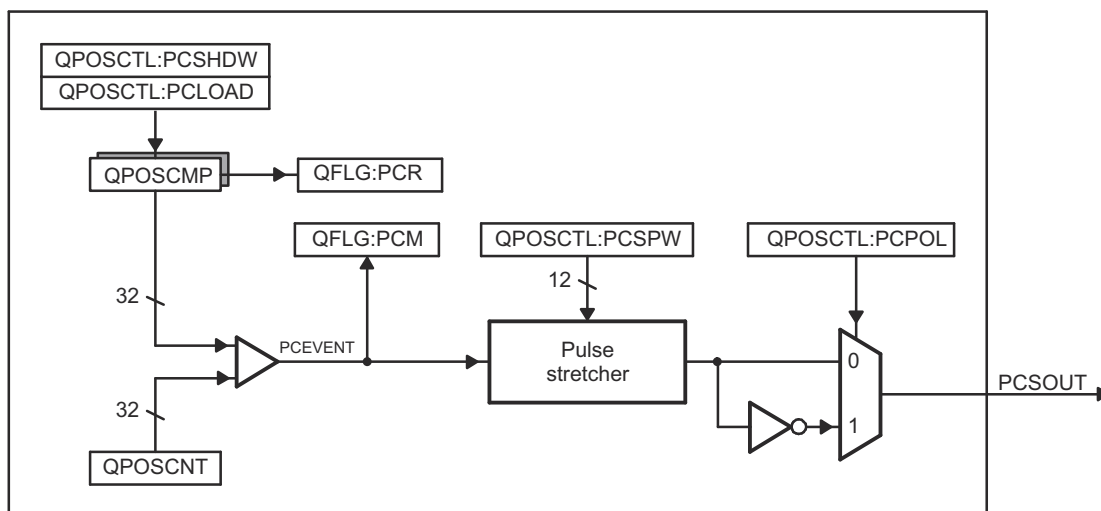

Figure 7-222. eQEP Position-compare Unit

In shadow mode, you can configure the position-compare unit (QPOSCTL[PCLOAD]) to load the shadow register value into the active register on the following events, and to generate the position-compare ready (QFLG[PCR]) interrupt after loading.

- Load on compare match
- Load on position-counter zero event

The position-compare match (QFLG[PCM]) is set when the position-counter value (QPOSCNT) matches with the active position-compare register (QPOSCMP) and the position-compare sync output of the programmable pulse width is generated on compare-match to trigger an external device.

For example, if QPOSCMP = 2, the position-compare unit generates a position-compare event on 1 to 2 transitions of the eQEP position counter for forward counting direction and on 3 to 2 transitions of the eQEP position counter for reverse counting direction (see Figure 7-223).

See the register section for the layout of the eQEP Position-Compare Control Register (QPOSCTL) and description of the QPOSCTL bit fields.

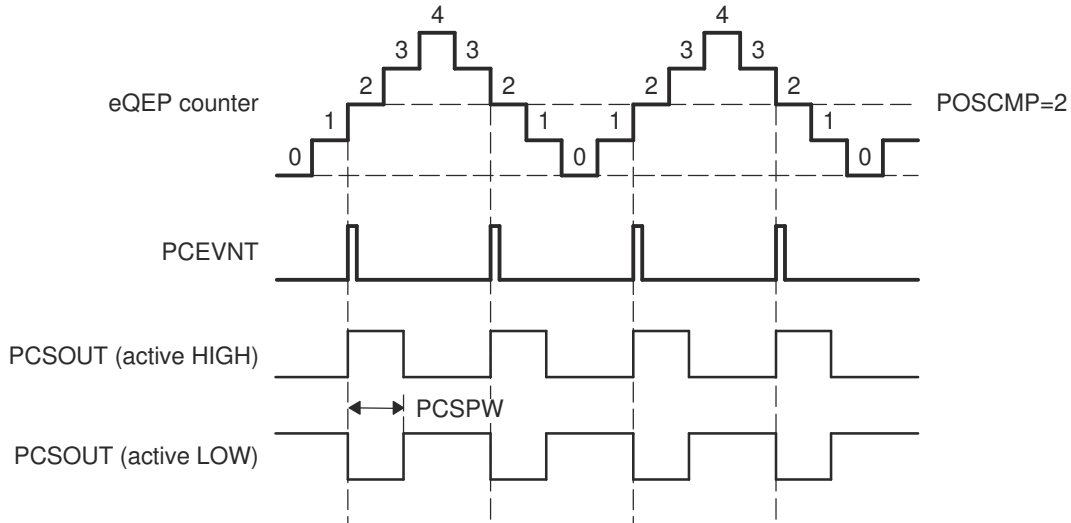

Figure 7-223. eQEP Position-compare Event Generation Points

The pulse stretcher logic in the position-compare unit generates a programmable position-compare sync pulse output on the position-compare match. In the event of a new position-compare match while a previous position-compare pulse is still active, then the pulse stretcher generates a pulse of specified duration from the new position-compare event as shown in Figure 7-224.

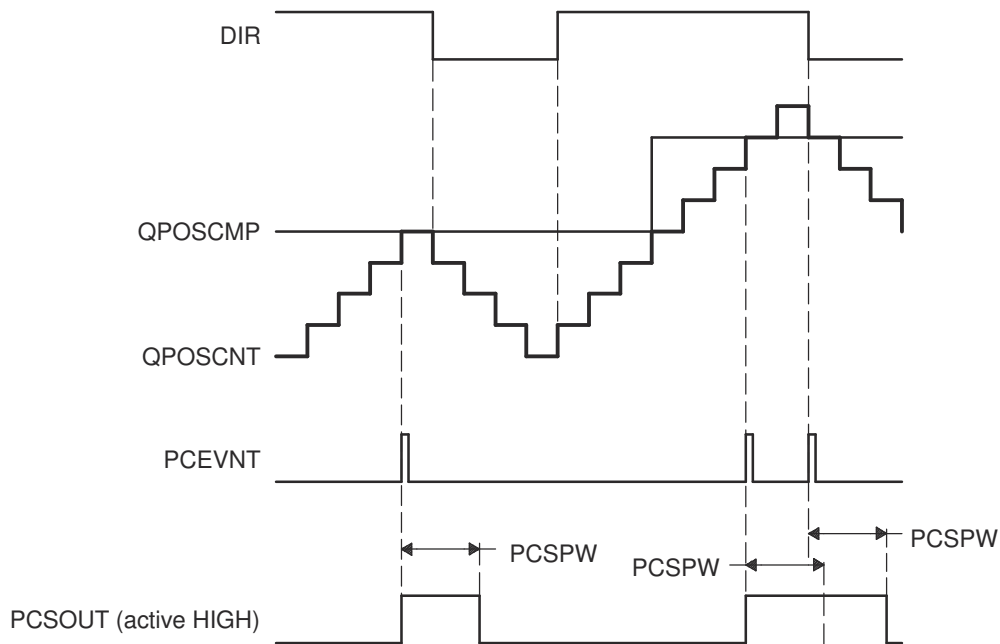

Figure 7-224. eQEP Position-compare Sync Output Pulse Stretcher

7.4.7.7 eQEP Edge Capture Unit

The eQEP peripheral includes an integrated edge capture unit to measure the elapsed time between the unit position events as shown in [Figure 7-225](#). This feature is typically used for low-speed measurement using the following formula:

$$v(k) = \frac{X}{t(k) - t(k - 1)} = \frac{X}{\Delta T} \quad (13)$$

where:

- X = Unit position is defined by integer multiple of quadrature edges (see [Figure 7-226](#))
- ΔT = Elapsed time between unit position events
- v(k) = Velocity at time instant "k"

The eQEP capture timer (QCTMR) runs from prescaled SYSCLKOUT and the prescaler is programmed by the QCAPCTL[CCPS] bits. The capture timer (QCTMR) value is latched into the capture period register (QCPRD) on every unit position event and then the capture timer is reset, a flag is set in QEPSTS:UPEVNT to indicate that new value is latched into the QCPRD register. Software can check this status flag before reading the period register for low speed measurement, and clear the flag by writing 1.

Time measurement (ΔT) between unit position events will be correct if the following conditions are met:

- No more than 65,535 counts have occurred between unit position events.
- No direction change between unit position events.

If the QEP capture timer overflows between unit position events, then it sets the QEP capture overflow flag (QEPSTS[COEF]) in the status register and the QCPRDLAT register is set to 0xFFFF. If direction change occurs between the unit position events, then the error flag is set in the status register (QEPSTS[CDEF]) and the QCPRDLAT register is set to 0xFFFF.

The Capture Timer (QCTMR) and Capture Period register (QCPRD) can be configured to latch on following events.

- CPU read of QPOSCNT register
- Unit time-out event

If the QEPCTL[QCLM] bit is cleared, then the capture timer and capture period values are latched into the QCTMRLAT and QCPRDLAT registers, respectively, when the CPU reads the position counter (QPOSCNT).

If the QEPCTL[QCLM] bit is set, then the position counter, capture timer, and capture period values are latched into the QPOSLAT, QCTMRLAT and QCPRDLAT registers, respectively, on unit time out.

[Figure 7-227](#) shows the capture unit operation along with the position counter.

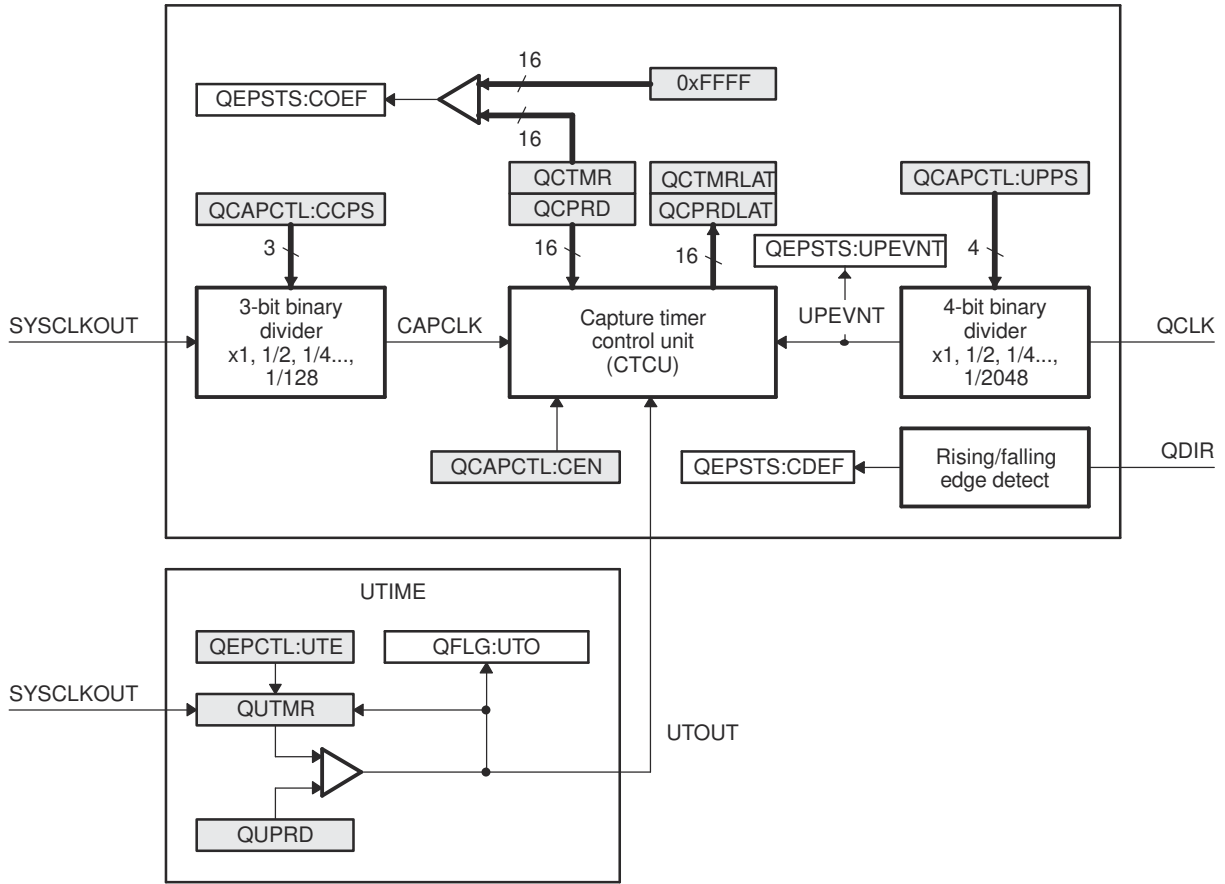
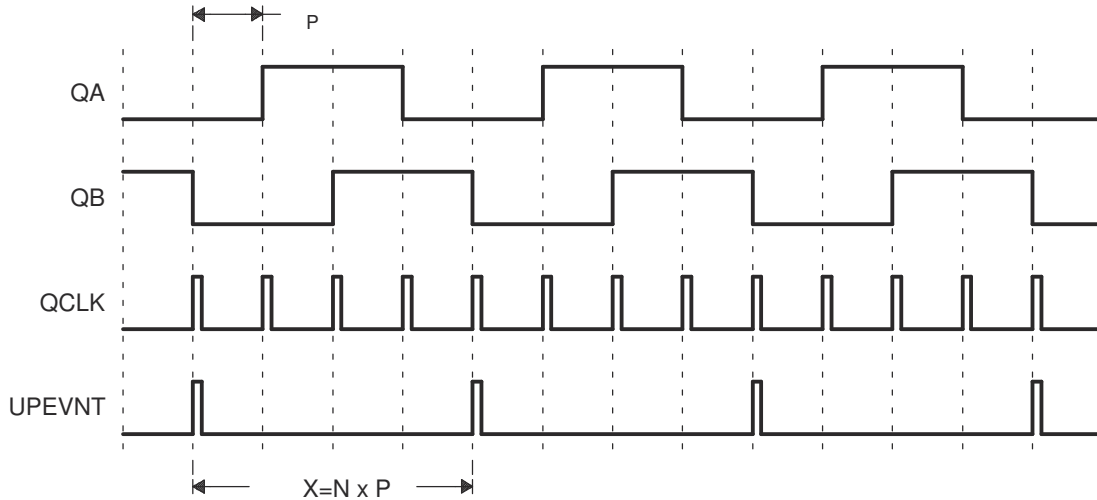

Figure 7-225. eQEP Edge Capture Unit

Note

The QCAPCTL[UPPS] prescaler should not be modified dynamically (such as switching the unit event prescaler from QCLK/4 to QCLK/8). Doing so may result in undefined behavior. The QCAPCTL[CCPS] prescaler can be modified dynamically (such as switching CAPCLK prescaling mode from SYSCLK/4 to SYSCLK/8) only after the capture unit is disabled.



N = Number of quadrature periods selected using QCAPCTL[UPPS] bits

Figure 7-226. Unit Position Event for Low Speed Measurement (QCAPCTL[UPPS] = 0010)

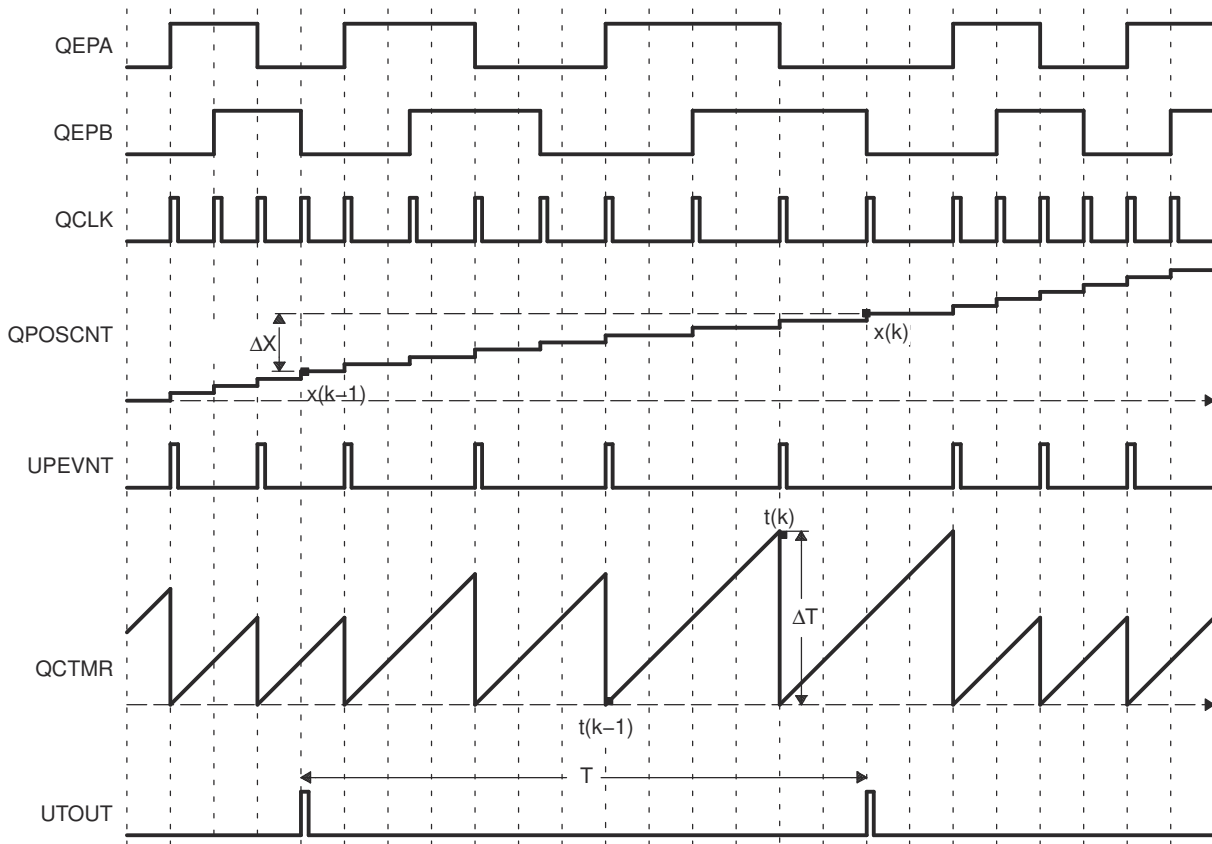

Figure 7-227. eQEP Edge Capture Unit - Timing Details

Velocity calculation equation:

$$v(k) = \frac{x(k) - x(k - 1)}{T} = \frac{\Delta X}{T} \quad (14)$$

where:

- $v(k)$ = Velocity at time instant k
- $x(k)$ = Position at time instant k
- $x(k-1)$ = Position at time instant $k-1$
- T = Fixed unit time or inverse of velocity calculation rate
- ΔX = Incremental position movement in unit time
- X = Fixed unit position
- ΔT = Incremental time elapsed for unit position movement
- $t(k)$ = Time instant "k"
- $t(k-1)$ = Time instant "k-1"

Unit time (T) and unit period (X) are configured using the QUPRD and QCAPCTL[UPPS] registers. Incremental position output and incremental time output is available in the QOSLAT and QCPRDLAT registers.

Parameter	Relevant Register to Configure or Read the Information
T	Unit Period Register (QUPRD)
ΔX	Incremental Position = QOSLAT(k) - QOSLAT($k-1$)
X	Fixed unit position defined by sensor resolution and ZCAPCTL[UPPS] bits
ΔT	Capture Period Latch (QCPRDLAT)

7.4.7.8 eQEP Watchdog

The eQEP peripheral contains a 16-bit watchdog timer (Figure 7-228) that monitors the quadrature clock to indicate proper operation of the motion-control system. The eQEP watchdog timer is clocked from SYSCLKOUT/64 and the quadrature clock event (pulse) resets the watchdog timer. If no quadrature clock event is detected until a period match (QWDPRD = QWDTMR), then the watchdog timer times out and the watchdog interrupt flag is set (QFLG[WTO]). The time-out value is programmable through the watchdog period register (QWDPRD).

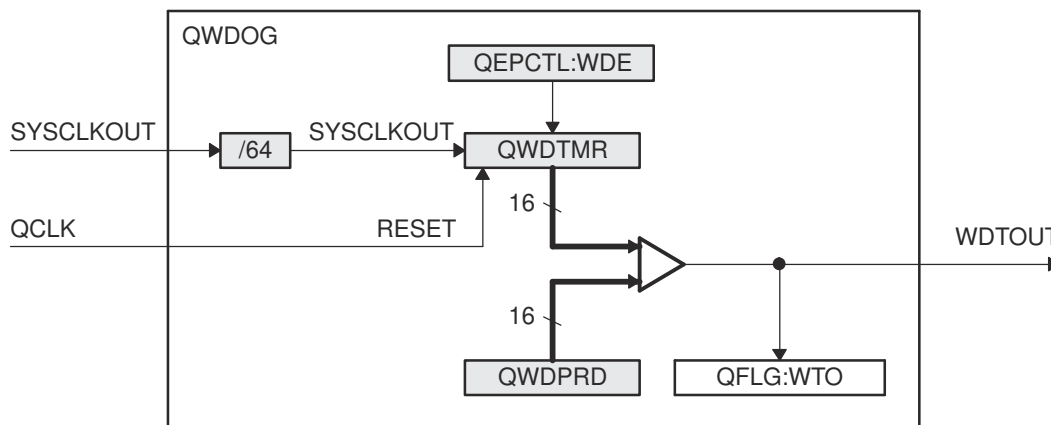

Figure 7-228. eQEP Watchdog Timer

7.4.7.9 eQEP Unit Timer Base

The eQEP peripheral includes a 32-bit timer (QUTMR) that is clocked by SYSCLKOUT to generate periodic interrupts for velocity calculations, see Figure 7-229. Whenever the unit timer (QUTMR) matches the unit period register (QUPRD), it resets the unit timer (QUTMR) and also generates the unit time out interrupt flag (QFLG[UТО]). The unit timer gets reset whenever timer value equals to configured period value.

The eQEP peripheral can be configured to latch the position counter, capture timer, and capture period values on a unit time out event so that latched values are used for velocity calculation as described in Section 7.4.7.7.

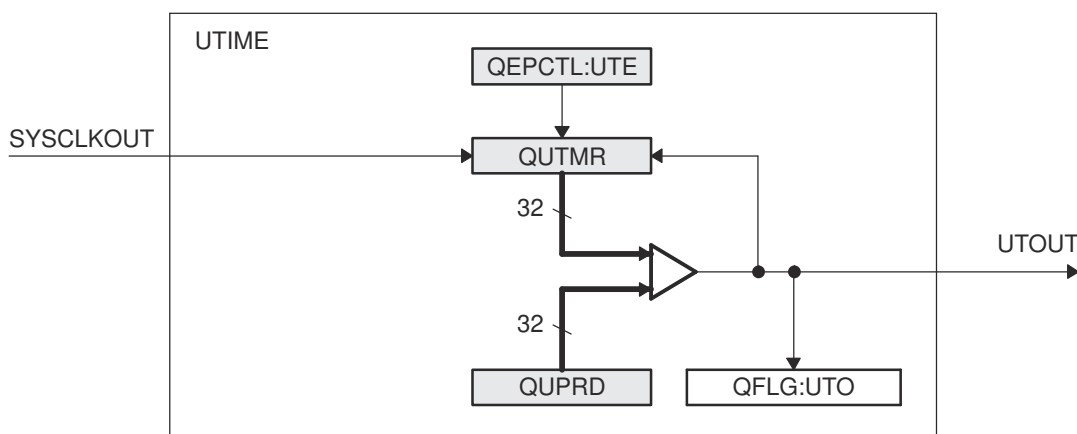

Figure 7-229. eQEP Unit Timer Base

7.4.7.10 eQEP Interrupt Structure

Figure 7-230 shows how the interrupt mechanism works in the eQEP module.

Figure 7-230. eQEP Interrupt Generation

Eleven interrupt events (PCE, PHE, QDC, WTO, PCU, PCO, PCR, PCM, SEL, IEL and UTO) can be generated. The interrupt control register (QEINT) is used to enable/disable individual interrupt event sources. The interrupt flag register (QFLG) indicates if any interrupt event has been latched and contains the global interrupt flag bit (INT).

An interrupt pulse is generated to PIE when:

1. Interrupt is enabled for eQEP event inside QEINT register
2. Interrupt flag for eQEP event inside QFLG register is set, and
3. Global interrupt status flag bit QFLG[INT] had been cleared for previously generated interrupt event. The interrupt service routine will need to clear the global interrupt flag bit and the serviced event, by way of the interrupt clear register (QCLR), before any other interrupt pulses are generated. If either flags inside the QFLG register are not cleared, further interrupt events will not generate an interrupt to PIE. You can force an interrupt event by way of the interrupt force register (QFRC), which is useful for test purposes.

7.4.8 Fast Serial Interface (FSI)

This chapter contains a general description of the Fast Serial Interface (FSI) module. The FSI is a serial peripheral capable of reliable high-speed communication across isolation barriers.

7.4.8.1 Introduction	635
7.4.8.2 System-level Integration	637
7.4.8.3 FSI Functional Description	643
7.4.8.4 FSI Programing Guide	668

7.4.8.1 Introduction

The Fast Serial Interface (FSI) module is a serial communication peripheral capable of reliable high-speed communication across isolation devices. Galvanic isolation devices are used in situations where two different electronic circuits, which do not have common power and ground connections, must exchange information. Though isolation devices facilitate these signal communications, they can also introduce a large delay on the signal lines and add skew between the signals. The FSI is designed specifically to ensure reliable high-speed communication for system scenarios that involve communication across isolation barriers without adding components.

The FSI consists of independent transmitter (FSITX) and receiver (FSIRX) cores. The FSITX and FSIRX cores are configured and operated independently.

For additional information on the FSI module, refer to [Fast Serial Interface \(FSI\) Skew Compensation](#).

7.4.8.1.1 FSI Features

The FSI module includes the following features:

- Independent transmitter and receiver cores
- Source-synchronous transmission
- Double Data Rate (DDR)
- One or two data lines
- Programmable data length
- DMA support
- Skew adjustment block to compensate for board and system delay mismatches
- Frame error detection
- Programmable frame tagging for message filtering
- Hardware ping to detect line breaks during communication (ping watchdog)
- Two interrupts per FSI core
- Hardware- or software-calculated CRC
- Embedded ECC computation module
- Register write protection
- FSI-SPI compatibility mode (limited features available)
- Tag match notifications

7.4.8.1.2 Block Diagram

This device contains 4 instance of FSI TX and FSI RX cores. The integration details are captured below:

ADVANCE INFORMATION

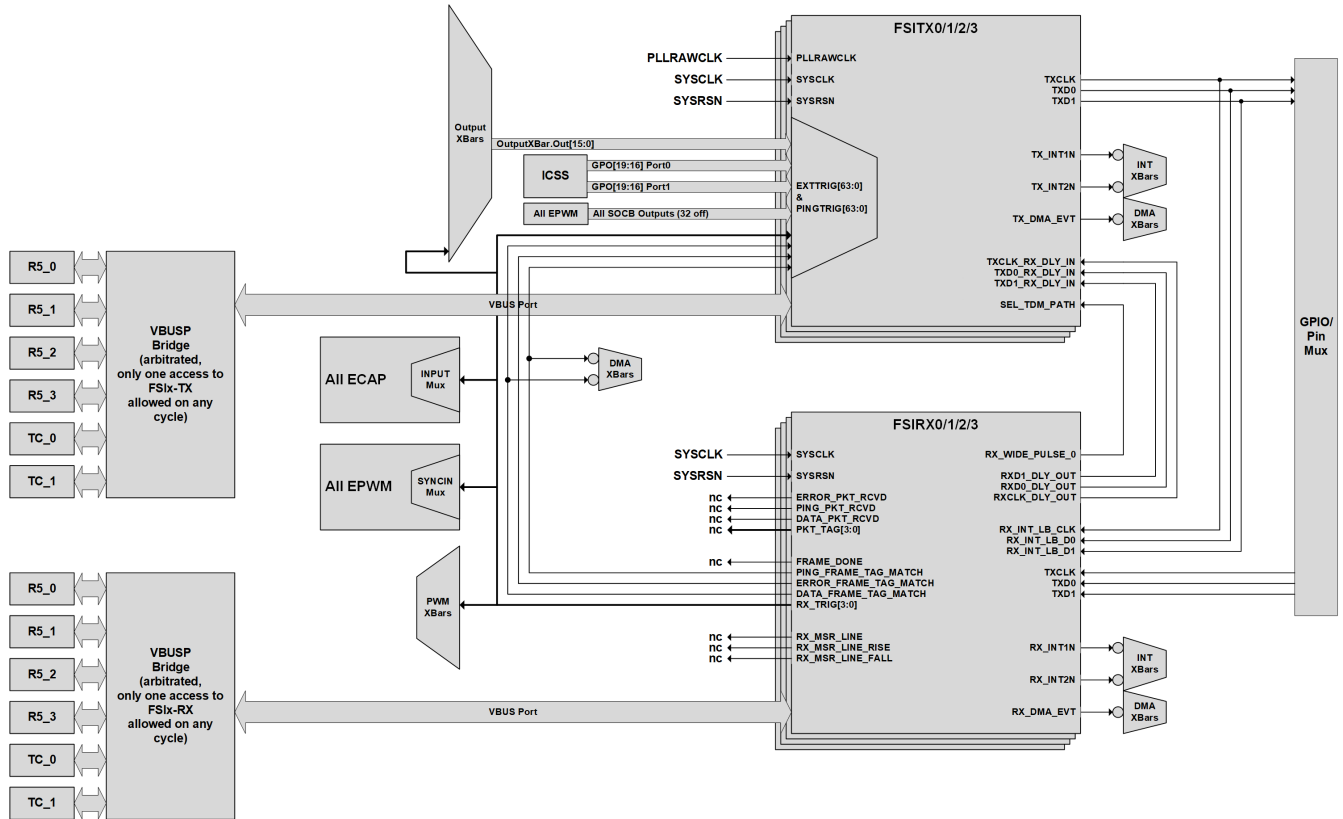

7.4.8.2 System-level Integration

This section describes the device-level integration of the FSI module. Some of the features may require additional configuration of modules that are not within the scope of this chapter, the details can be found elsewhere in this TRM.

7.4.8.2.1 Signal Description

FSI is a point-to-point communication protocol. Hence, an FSI transmitter core will communicate directly to a single FSI receiver core. Similarly, an FSI receiver core will receive data from a single FSI transmitter core.

Each FSI core has three signals associated with it: one clock and two data signals. Data is always transmitted or received with the most significant bit of each frame field being first. If multi-lane transmissions are not used, the TXD1 and RXD1 signals can be left unconnected and their GPIOs repurposed for other application needs. [Table 7-130](#) and [Table 7-131](#) describe the various signals that can be selected by the PADCONFIG register to be brought out to device pins.

CAUTION

The maximum RXCLK rate is SYSCLK/2 and should not exceed this limit.

Table 7-130. FSI Receiver Core Signals

Signal Name	Direction	Description	Inactive Level ⁽¹⁾
RXCLK	Input	This is the receive clock input signal for the FSI receive module. This must should be connected to TXCLK of the transmitting FSI module.	Logic High
RXD0	Input	This is the primary data input line for reception. This should be connected to the TXD0 of the transmitting FSI module.	Logic High
RXD1	Input	This is an additional data input line for reception. This signal should be connected to the TXD1 of the transmitting FSI module if multi-lane transmission is used.	Logic High

(1) Inactive level refers to the state of the pin while the module is not actively receiving data.

Table 7-131. FSI Transmitter Core Signals

Signal Name	Direction	Description	Inactive Level ⁽¹⁾
TXCLK	Output	This is the transmit clock. It is driven by the FSI transmit module. During a transmission, four clock edges will be transmitted before the start of frame phase (preamble) and four clock edges will follow the last bit of the frame (postamble). Data is transmitted on both edges of the clock. In FSI-SPI compatibility mode, the preamble and the post frame clock edges will not be transmitted. Data is transmitted only on one edge of the clock. Data will transmit on rising edge and received on falling edge of the clock.	Logic High
TXD0	Output	This is the primary data output line for transmission. This signal is driven by the FSI transmit module. When the FSI is configured for multi-lane transmission, TXD0 will contain all the even numbered bits of the data and CRC bytes. Other frame fields such as frame type, start-of-frame, tag, and end-of-frame will be transmitted in full.	Logic High
TXD1	Output	This is an additional data output line for transmission if the FSI is configured for multi-lane transmission. This signal is driven by the FSI transmit module. During transmission, the data bits are split between TXD0 and TXD1. TXD1 will contain all the odd numbered bits of the data and CRC bytes. This applies only to the data words and the CRC bytes. Other data frame related information like Frame Type, Start-of-Frame, Tag and End-of-frame, the state of this line will be identical to TXD0.	Logic High

(1) Inactive level refers to the state of the pin while the module is not actively transmitting, or held in reset.

7.4.8.2.1.1 Configuring Device Pins

The GPIO mux registers must be configured to connect this peripheral to the device pins. To avoid glitches on the pins, the GPyGMUX bits must be configured first (while keeping the corresponding GPyMUX bits at the default of zero), followed by writing the GPyMUX register to the desired value.

Some IO functionality is defined by GPIO register settings independent of this peripheral. For input signals, the GPIO input qualification should be set to asynchronous mode by setting the appropriate GPxQSELn register bits to 0x3. The internal pullups can be configured in the GPyPUD register. See the *General Purpose Input-Output (GPIO)* chapter for more details on the GPIO mux and settings.

7.4.8.2.2 FSI Interrupts

Each FSI module contains multiple interrupt sources which can be assigned to two different interrupt vectors: INT1 and INT2. Each interrupt source has an associated status flag, force, and clear bits in the EVT_STS, EVT_FRC, and the EVT_CLR registers, respectively.

Each interrupt can be assigned to either interrupt vector, INT1 and INT2, to allow for two priority levels. Alternately, the interrupt source can be prevented from generating any interrupt, though the status flag can still be set and monitored by software. The transmitter events are assigned to either interrupt vector in the TX_INT_CTRL register. The receiver events are assigned an interrupt vector using RX_INT1_CTRL and RX_INT2_CTRL registers. If an interrupt is not required, ensure the bit is not set in the respective INT_CTRL register.

7.4.8.2.2.1 Transmitter Interrupts

The transmitter can generate the following interrupts:

- **Frame Done (FRAME_DONE):** This event indicates that FSI has completed transmitting a frame.
- **Buffer Underrun (BUF_UNDERRUN):** This event indicates that the transmit buffer has experienced underrun. Buffer underrun occurs when the transmitter tries to read data from a location which has not yet be written to by the CPU, or DMA.
- **Buffer Overrun (BUF_OVERRUN):** The buffer overrun interrupt is generated when the buffer has experienced overrun. Buffer overrun may occur if a piece of data is overwritten before it has been transmitted.
- **Ping Frame Triggered (PING_TRIGGERED):** The ping frame triggered interrupt is generated when the ping frame has been triggered. This bit will be set when the ping counter has timed out or an external ping trigger event has occurred.

7.4.8.2.2 Receiver Interrupts

The receiver core is capable of generating interrupts from many different events:

- **Ping Watchdog Timeout (PING_WD_TO):** This event indicates that the ping watchdog timer has timed out. The receiver has not received a valid frame within the time period specified in the RX_PING_WD_REF register.
- **Frame Watchdog Timeout (FRAME_WD_TO):** This event indicates that the frame watchdog timer has timed out. The conditions of this timeout are set using the RX_FRAME_WD_CTRL register. As soon as the start of frame phase is detected, the frame watchdog counter starts counting from 0. The end of frame phase must complete by the time the watchdog counter reaches the reference value. If this does not happen, the watchdog times out and this event is generated. If this event occurs, the receiver must undergo a soft reset and subsequent resynchronization to resume proper operation.
- **CRC Error (CRC_ERR):** This error indicates that a CRC error has occurred. A CRC error is generated when the received CRC and the computed CRC do not match.
- **Frame Type Error (TYPE_ERR):** This error indicates that an invalid frame type has been received. If this error occurs, the receiver must undergo a soft reset and subsequent resynchronization to resume proper operation.
- **End-of-Frame Error (EOF_ERR):** This error indicates that an invalid end-of-frame bit pattern has been received. If this error occurs, the receiver must undergo a soft reset and subsequent resynchronization to resume proper operation.
- **Receive Buffer Overrun (BUF_OVERRUN):** This event indicates that an overrun condition has occurred in the receive buffer.
- **Receive Buffer Underrun (BUF_UNDERRUN):** This event indicates that an underrun condition has occurred in the receive buffer. This condition occurs when software reads an empty buffer.
- **Frame Done (FRAME_DONE):** This event indicates that a valid frame has been received without error.
- **Error Frame Received (ERR_FRAME):** This event indicates that an error frame has been received.
- **Ping Frame Received (PING_FRAME):** This event indicates that a ping frame has been received.
- **Frame Overrun (FRAME_OVERRUN):** This event indicates that a new frame has been received while the FRAME_DONE flag was still set.
- **Data Frame Received (DATA_FRAME):** This event indicates that a data frame has been received.
- **Ping Tag Matched (PING_TAG_MATCH):** This event indicates that a ping frame with a matching tag has been received.
- **Data Tag Matched (DATA_TAG_MATCH):** This event indicates that a data frame with a matching tag has been received.
- **Error Tag Matched (ERROR_TAG_MATCH):** This event indicates that an error frame with a matching tag has been received.

7.4.8.2.3 Configuring Interrupts

To configure interrupts on the FSI, the application should select the interrupt vector for each desired event using the TX_INT_CTRL register for the transmitter, and RX_INT1_CTRL and RX_INT2_CTRL registers for the receiver. There is no module-level interrupt enable bit to configure.

Note

If an event is registered for both interrupt vectors, both interrupts will fire. There are no hardware checks for overlapping interrupt vector assignments.

7.4.8.2.4 Handling Interrupts

Inside the interrupt service routine (ISR), the user should clear the event flag using the EVT_CLR register and then acknowledge the CPU interrupt.

If the one event occurs multiple times before the corresponding bit is cleared by software, no new interrupt will be generated.

If multiple events occur simultaneously, or very close in time, it is possible to handle multiple conditions within a single interrupt. Each flag is independently set by hardware and must be cleared by application software. If multiple different events occur, the ISR can handle each in whatever order is deemed necessary by the application. It is not advisable to clear the full interrupt status register in every ISR. This may cause the application to miss events that may be detrimental to the application. A sample sequence for handling interrupts on the receiver follows; the transmitter routine will be similar.

- On receiving an interrupt, copy the current state of the receive event and error status flag register (RX_EVT_STS) into a local snapshot variable.
- Read all of the bits from the snapshot to determine the events that require action.
- Perform the necessary actions for each of the events seen in the snapshot.
- Write to the receive event and error clear register (RX_EVT_CLR) with the snapshot to clear only those interrupts that were set at the beginning of the ISR.
- Repeat this sequence for every generated ISR.

There is a chance that another event occurred during the just-handled ISR since only the snapshot of events was handled and then cleared; an event flag may still be set at the end of the ISR. As soon as the ISR completes, a new interrupt will be generated and this flag will still be set and can be handled accordingly.

Software accesses tied to multiple events and handled within the same ISR may cause race conditions which will cause the software to not function as desired. For example, it is recommended to use different interrupt lines if the user wants to enable events for both ping and data frames. If both are handled within the same interrupt line, the software may only respond to one of the events if they both occur close in time.

7.4.8.2.3 DMA Interface

Both the transmitter and receiver are capable of using the DMA for automatic data transfers. The DMA trigger is independent from the interrupt signals. DMA events are only triggered on the completion of a data frame.

The transmitter DMA trigger is enabled by setting TX_DMA_CTRL.DMA_EVT_EN to 1. The transmitter must also set TX_OPER_CTRL_LO.START_MODE to 0x2 to allow either a write to the TX_FRAME_CTRL.START bit or to the TX_FRAME_TAG_UDATA register to start the transmission.

The receiver DMA trigger is enabled by setting RX_DMA_CTRL.DMA_EVT_EN to 1.

Refer to [Section 7.4.8.3.2](#) and [Section 7.4.8.3.3](#) for more DMA information specific to each FSI Module.

7.4.8.2.4 External Frame Trigger Mux

The FSI has two muxes connected to the transmitter module. These muxes are used to select triggers to start ping frames, and/or generic frames. These muxes are independently configured for each type of frame. The application may select one trigger source per frame type. Use of these triggers are optional.

The external ping frame trigger is configured by setting TX_PING_CTRL.EXT_TRIG_SEL to the index of the desired trigger. TX_PING_CTRL.EXT_TRIG_EN must also be set to allow the trigger to generate a ping frame.

The generic frame trigger is configured by setting TX_OPER_CTRL_HI.EXT_TRIG_SEL to the index of the desired trigger. TX_OPER_CTRL_LO.START_MODE must be set to 0x1 in order for a frame to be transmitted by an external trigger.

Note

Triggers generated by EPWM XBAR are asynchronous and must be at least 3 SYSCLKs wide.

Table 7-132. External Trigger Sources and Their Index

Index	External Trigger Source
0	FSI_RXx.PING_FRAME_TAG_MATCH
1	FSI_RXx.ERROR_FRAME_TAG_MATCH
2	FSI_RXx.DATA_FRAME_TAG_MATCH
3	Tie low
4	FSI_RXx.TRIG0
5	FSI_RXx.TRIG1
6	FSI_RXx.TRIG2
7	FSI_RXx.TRIG3
8	EPWM0.SOCB
9	EPWM1.SOCB
10	EPWM2.SOCB
11	EPWM3.SOCB
12	EPWM4.SOCB
13	EPWM5.SOCB
14	EPWM6.SOCB
15	EPWM7.SOCB
16	EPWM8.SOCB
17	EPWM9.SOCB
18	EPWM10.SOCB
19	EPWM11.SOCB
20	EPWM12.SOCB
21	EPWM13.SOCB
22	EPWM14.SOCB
23	EPWM15.SOCB
24	EPWM16.SOCB
25	EPWM17.SOCB
26	EPWM18.SOCB
27	EPWM19.SOCB
28	EPWM20.SOCB
29	EPWM21.SOCB

Table 7-132. External Trigger Sources and Their Index (continued)

Index	External Trigger Source
30	EPWM22.SOCB
31	EPWM23.SOCB
32-39	Reserved
40	ICSM_PORT0.16
41	ICSM_PORT0.17
42	ICSM_PORT0.18
43	ICSM_PORT0.19
44	ICSM_PORT1.16
45	ICSM_PORT1.17
46	ICSM_PORT1.18
47	ICSM_PORT1.19
48	OUTPUTXBAR.OUT0
49	OUTPUTXBAR.OUT1
50	OUTPUTXBAR.OUT2
51	OUTPUTXBAR.OUT3
52	OUTPUTXBAR.OUT4
53	OUTPUTXBAR.OUT5
54	OUTPUTXBAR.OUT6
55	OUTPUTXBAR.OUT7
56	OUTPUTXBAR.OUT8
57	OUTPUTXBAR.OUT9
58	OUTPUTXBAR.OUT10
59	OUTPUTXBAR.OUT11
60	OUTPUTXBAR.OUT12
61	OUTPUTXBAR.OUT13
62	OUTPUTXBAR.OUT14
63	OUTPUTXBAR.OUT15

7.4.8.3 FSI Functional Description

7.4.8.3.1 FSI Functional Description

The Fast Serial Interface Transmitter and Receiver modules (FSI_TX/FSI_RX) are two completely independent modules on the device. Each module has an independent set of control registers, clocking, and interrupts. The following sections describe the frame format and the various initialization and configuration procedures for both the transmitter and receiver.

7.4.8.3.2 FSI Transmitter Module

The FSI transmitter module handles the framing of data, CRC generation, and signal generation of TXCLK, TXD0, and TXD1, as well as interrupt generation. The operation of the transmitter core is controlled and configured through programmable control registers. The transmitter control registers allow the CPU to program, control, and monitor the operation of the FSI receiver. The transmit data buffer is accessible by the CPU and the DMA.

The transmitter has the following features:

- Automated ping frame generation
- Externally triggered ping frames
- Externally triggered data frames
- Software-configurable frame lengths
- Programmable TX delay line control
- 16-word data buffer
- Data buffer underrun and overrun detection
- Hardware-generated CRC on data bits
- Software ECC calculation on select data
- DMA support

Figure 7-231 shows the high-level block diagram of the FSI transmitter. Figure 7-232 shows the block diagram of the transmitter core submodule.

The following sections describe the various aspects of the FSI transmitter in detail.

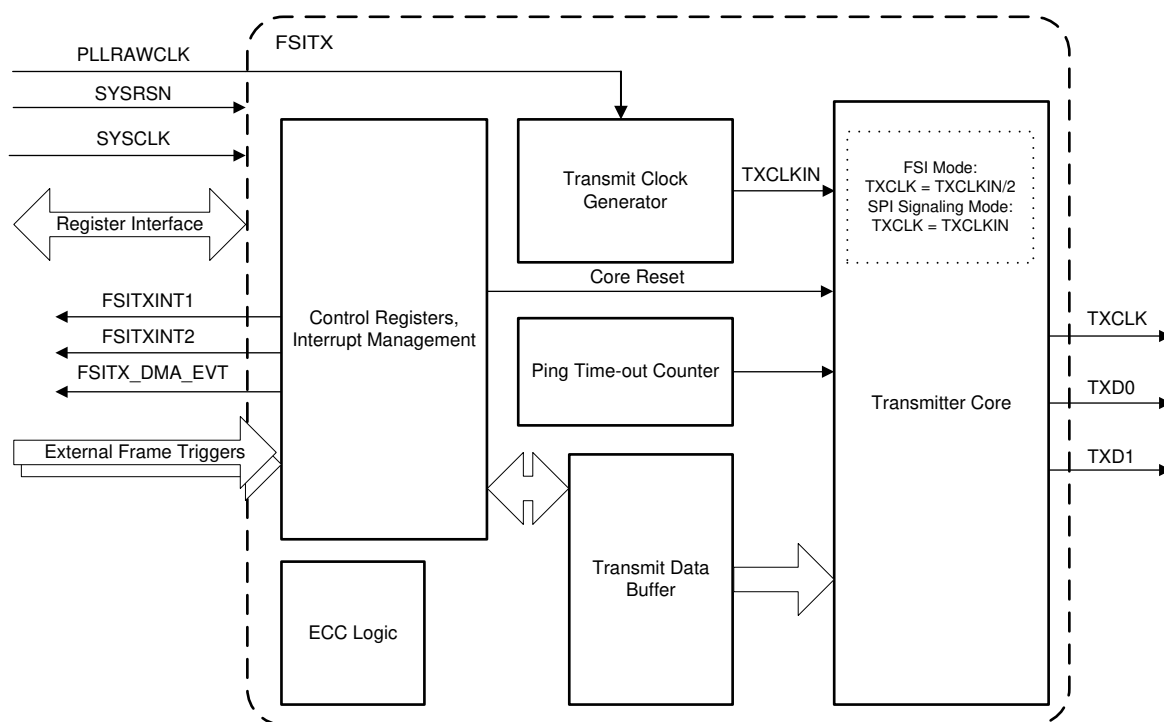

Figure 7-231. FSI Transmitter Block Diagram

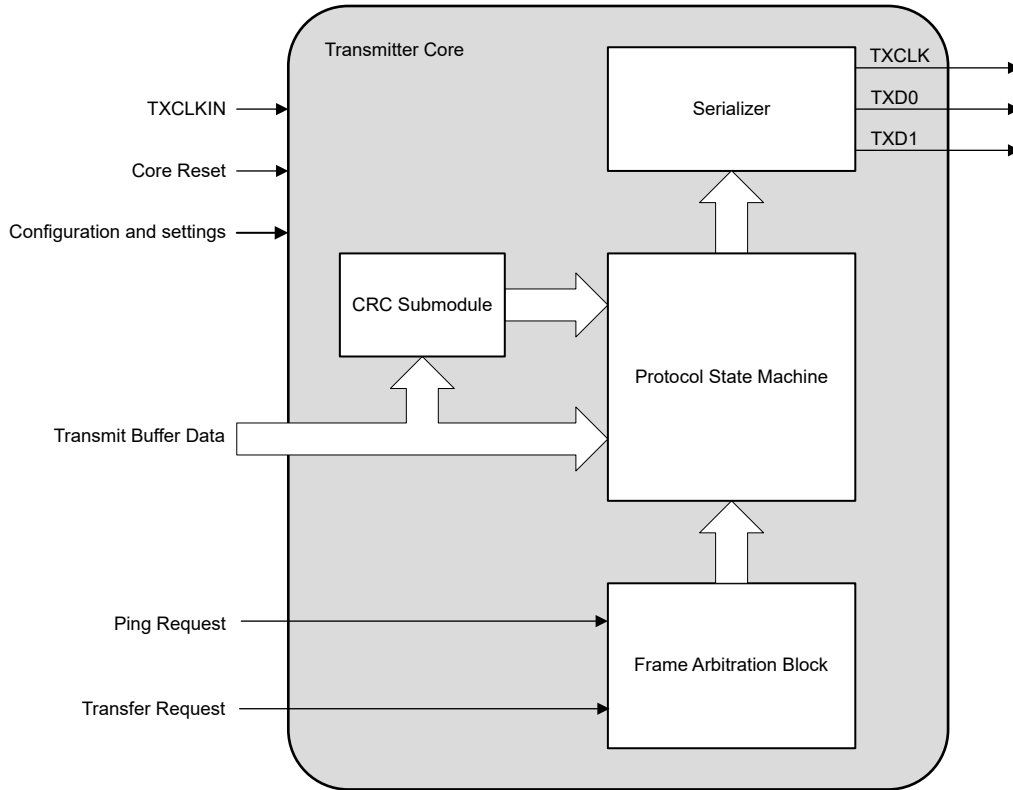

Figure 7-232. FSI Transmitter Core Block Diagram

7.4.8.3.2.1 Initialization

On the first initialization or after a module reset due to an underrun condition, the transmitter module executes the following initialization sequence to start or resume transmit operations.

1. Initialize the transmitter clock by setting TX_CLK_CTRL.CLK_RST to 1 and subsequently clearing the bit.
2. Set the clock to the transmitter core to PLLRAWCLK by setting TX_OPER_CTRL_LO.SEL_PLLCLK to 1.
3. Set the clock prescaler value to the desired rate by writing to TX_CLK_CTRL.PRESCALE_VAL.
4. Enable the transmitter clock divider by setting TX_CLK_CTRL.CLK_EN to 1.
5. Assert the transmitter module soft reset by writing 0xA501 to TX_MAIN_CTRL.
6. Wait four TXCLK cycles.
7. Release the transmitter core from reset by writing 0xA500 to TX_MAIN_CTRL.

After initialization and configuration, the transmitter module synchronizes with the receiver module before transmitting. The synchronization sequence is described in [Section 7.4.8.4.1](#).

CAUTION

Do not change TX_CLK_CTRL.PRESCALE_VAL while the clock is enabled (TX_CLK_CTRL.CLK_EN = 1). Doing so can cause undefined behavior.

7.4.8.3.2.2 FSI_TX Clocking

The transmitter core registers and control logic run off of the device system clock (SYSCLK).

The FSI Transmit Clock (TXCLK) is derived from PLLRAWCLK. PLLRAWCLK is divided down by configuring the clock prescaler value (TX_CLK_CTRL.PRESCALE_VAL) then setting the clock divider enable bit (TX_CLK_CTRL.CLK_EN). The clock prescaler value can be set to divide PLLRAWCLK by 1 (TX_CLK_CTRL.PRESCALE_VAL = 0x0 or 0x1) through 255 (TX_CLK_CTRL.PRESCALE_VAL = 0xFF). Though TXCLK and SYSCLK are both derived from PLLRAWCLK, TXCLK is asynchronous with respect to SYSCLK.

CAUTION

TXCLK should never be configured to be faster than SYSCLK/2.

7.4.8.3.2.3 Transmitting Frames

On the transmitter, the ping frame is the only frame which can be set up and transmitted without any further software or DMA intervention. Ping frames can be transmitted by any (or all) of the three sources: automatic ping timer, software, or external triggers.

Each available frame type can be sent multiple ways. Generically, the following steps must be executed before the frame is sent. These steps may be executed in any order before the start condition is set.

1. Configure the frame type
2. Set the frame tag
3. If the frame to be sent is a data frame:
 - Set the user data
 - Write to the data buffer
 - Set the word length if the frame is a software defined frame length
4. Set the start condition

Note

Transmit Frame Start Restriction:

A new frame transmission can be initiated by one of the methods selected in the TX_OPER_CTRL_LO.START_MODE bits. If there is already a PING frame transmission taking place, due to a hardware initiated PING timer, the new frame transmission will begin as soon as the on-going PING transmission is completed.

Once a START of frame has been initiated, the next START of frame will be recognized when the first frame has started transmitting the End-of-Frame (EOF) field. If a new START trigger arrives before the current transmission has reached the EOF field, the trigger will be lost without a notification.

Note

There is no hardware check implemented to check whether the type field written by software is valid or not. If an invalid type is used and a frame transmission is initiated, the behavior will be as follows:

- The transmitted frame structure will be exactly like an NWORD data frame. The size of the data frame will be determined by the value in the TX_FRAME_CTRL.N_WORDS register.
- The frame type field of the transmitted data frame will be transmitted as programmed. If this is received by an FSI receiver, it will generate a Type error.

This mechanism can be used to force a Type error in a received frame for testing purposes.

The following sections describe the specific configuration for each frame type and start condition.

7.4.8.3.2.3.1 Software Triggered Frames

The most basic way to transmit a data frame is through software. Each step must be handled by the application. To send a data frame using software, the following steps should be executed. Steps 1-6 may be executed in any order before setting TX_FRAME_CTRL.START. Some fields may not need to be reconfigured for every transmission. The frame tag, user data, and frame type are sticky and will be re-transmitted in the subsequent frame unless they are modified by software.

1. Write the data to be transmitted to the next location of the transmit data buffer.
2. Set TX_FRAME_CTRL.FRAME_TYPE to the appropriate value for the type of frame to be transmitted.
3. Set TX_FRAME_CTRL.N_WORDS to 1 less than the number of words to be transmitted if TX_FRAME_CTRL.FRAME_TYPE is set to 0011, the frame type of the software-defined length data frame. That is, if 16 words will be transmitted, N = 16, set TX_FRAME_CTRL.N_WORDS to 15.
4. When the frame is assembled before transmitting, the FSITX hardware will calculate the CRC to be transmitted. If TX_OPER_CTRL_LO.SW_CRC is 1, the application may calculate a custom CRC value and then set TX_USER_CRC to the result.
5. Set TX_FRAME_TAG_UDATA.FRAME_TAG to the desired tag.
6. Set TX_FRAME_TAG_UDATA.USER_DATA to the desired user data.
7. Set TX_FRAME_CTRL.START to 1 to initiate the transmission of the data frame.

Once the frame transmission has started, the TX_FRAME_CTRL.START will be cleared by hardware. To monitor if the frame has completed, the software can poll TX_EVT_STS.FRAME_DONE.

7.4.8.3.2.3.2 Externally Triggered Frames

The transmitter can transmit frames when triggered by an external source. See [Section 7.4.8.2.4](#) for more information on the available external triggers.

To transmit frames using an external trigger, the application must follow the same procedure as described in [Section 7.4.8.3.2.3.1](#). The only difference is that in Step 7, the start condition will be automatically set when the external trigger condition is met rather than by software.

It is important to note that by externally triggering frames, the frame information to be sent will be pulled from the same registers described in the previous section. Because of this, it is possible to send any type of frame from an external trigger including ping, error, and data frames. Also, there is no hardware mechanism by which the FSI can determine if multiple triggers occur. The FSITX will take the data as is, and the application software should ensure that this data has been updated as necessary.

Using TX_EVT_STS fields either by polling or by interrupts, the application can populate or update the frame information to be sent in the next frame

7.4.8.3.2.3.3 Ping Frame Generation

Assuming the FSI transmitter has already been properly initialized, the following sequences can be used to configure and send ping frames.

7.4.8.3.2.3.3.1 Automatic Ping Frames

To generate periodic ping frames, the following steps must be followed:

1. Initialize the ping counter by writing 1 to TX_PING_CTRL.CNT_RST.
2. Set the desired ping tag to TX_PING_TAG.TAG.
3. Set the ping timer reference value to TX_PING_TO_REF.TO_REF.
4. Enable the ping timer by writing 1 to TX_PING_CTRL.TIMER_EN.

The ping timer is a free-running counter which will count up from 0. The current value of the ping timer counter is found in TX_PING_TO_CNT. When the current value of TX_PING_TO_CNT matches the reference value TX_PING_TO_REF.TO_REF, TX_EVT_STS.PING_TRIGGERED will be set. TX_PING_TO_CNT will reset to 0 and resume counting until the next match has occurred or the ping timer is halted by software (TX_PING_CTRL.TIMER_EN is set to 0).

7.4.8.3.2.3.3.2 Software Triggered Ping Frame

Software can also manually generate a ping frame. The process for sending a ping frame with software is very similar to sending the other types of frames. The following steps must be followed:

1. Set TX_FRAME_CTRL.FRAME_TYPE to 0000'b to denote that the frame being sent will be a Ping Frame.
2. Set TX_FRAME_TAG_UDATA.FRAME_TAG to the desired value.
3. Write 1 to TX_FRAME_CTRL.START. This will start the transmission.

Once the frame transmission has started, the TX_FRAME_CTRL.START will be cleared by hardware. To monitor if the frame has completed, the software can poll TX_EVT_STS.FRAME_DONE.

7.4.8.3.2.3.3.3 Externally Triggered Ping Frame

The last source for generating ping frames is an external trigger. One of up to 32 different triggers may be selected. See [Section 7.4.8.2.4](#) for the list of input sources.

CAUTION

Ping frames can be triggered by both an external trigger source and the internal ping timer. If TX_PING_CTRL.EXT_TRIG_EN is set to 1, it will take precedence and the ping timer will be ignored.

7.4.8.3.2.3.4 Transmitting Frames with DMA

The FSI transmitter can send data which is continuously fed with the DMA. A DMA trigger will be generated every time a data frame transmission is completed. This is concurrent with the FRAME_DONE signal that sets the TX_EVT_STS.FRAME_DONE flag.

In order to transmit continuous data with the DMA, some configurations need to be made on the transmitter:

First, set TX_DMA_CTRL.DMA_EVT_EN to 1. This will allow the DMA trigger to propagate to the DMA module. Next, TX_OPER_CTRL_LO.START_MODE must be set to 0x2. The transmitter is now able to start a transmission using a software write to TX_FRAME_CTRL.START or TX_FRAME_TAG_UDATA..

The DMA must also be configured properly for the FSI to send the data. One possible solution of using the DMA to continuously feed the transmit buffer is shown below:

- Set up two DMA channels to be triggered by the same FSI transmitter and DMA trigger.
- Configure one channel to fill the transmit buffer.
- Configure the other channel to set the frame tag and user data fields
- Since the FSI transmit buffer is a 16-word circular buffer, ensure the DMA channel servicing the data buffer wraps the after 16 words are copied.

Note

Because the frame tag and user data must be written in to in order to initiate the transmission of the frame, use two consecutive DMA channels. This ensures that the DMA channels are always executed in sequence. The DMA channel servicing the data buffer should be the lower numbered channel and the tag/user data channel should be the next. For example, configure DMA channel 3 to service the data buffer, and configure DMA channel 4 to service the tag and user data.

7.4.8.3.2.4 Delay Line Control

The transmitter module has a programmable delay line on each of the external signal inputs: TXCLK, TXD0, and TXD1. The delay elements introduce delays on the respective lines and are placed before the FSITX signals are sent to the TDM signal selection mux (controlled by the SEL_TDM_PATH signal). This is to facilitate adjustment for signal delays introduced by system level components such as signal buffers, ferrite beads, isolators, and so on, or board delays such as uneven trace lengths, long cable length, and so on. The length of the delay is controlled by setting the TX_DLY_LINE_CTRL register values for each line. By default, no delay is introduced by the delay line elements. The delay values should only be adjusted while the FSITX is held in soft reset, ensuring that there are no active transmissions during this process. Figure 7-236 shows a representation of the delay line circuitry for the input signals. The implementation for TXCLK, TXD0, and TXD1 are replicas of this diagram. All circuits will behave similarly.

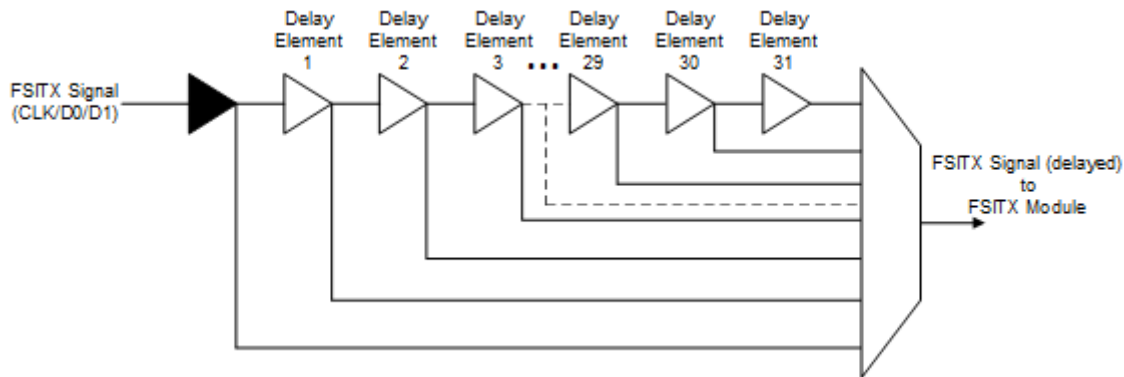

Figure 7-233. Delay Line Control Circuit

For more information on skew compensation, refer to the [Fast Serial Interface \(FSI\) Skew Compensation Application Report](#).

7.4.8.3.2.5 Transmit Buffer Management

The FSI transmitter has a 16-word buffer from which it pulls data to transmit. This buffer is implemented as a circular buffer, not a FIFO, so some care must be taken to properly interpret buffer overrun and underrun, as well as the TX_BUF_PTR_STS register. These flags and pointers work under the assumption that the software or DMA is using the buffer as a circular buffer. This mode of operation is the only way in which the overrun, underrun, and pointer status are meaningful. If data is being sourced by the DMA and there is some other periodic trigger mechanism trying to initiate transfers, underrun becomes a critical error. If an underrun happens, it means that the buffer went out of sync. This would not only affect the current transfer, but all future transfers also could not be guaranteed due to the ring buffer. Under such conditions, the underrun would need a soft reset to cleanly recover. Alternately, the software could manually stop the transmitting, reset the buffer pointers, clear the remaining error conditions, and then restart transmission. The software method involves a few steps, while the soft reset is a single action and will guarantee a full reset of the control registers.

Due to the flexibility of the transmit buffer, it is possible for software to implement a simple ping-pong buffer, or to randomly load and send from any location of the buffer. If the buffer is used in this manner, error flags and status fields may be ignored without adversely affecting the transmitter capability. Additionally, the CURR_WORD_CNT will also be invalid if used in this way. The application can set the buffer pointer manually by writing the 4-bit index to TX_BUF_PTR_LOAD. This will force the transmitter to start picking the data from the indicated location in the buffer.

7.4.8.3.2.6 CRC Submodule

The FSI transmitter can supply the CRC to the frame being transmitted through the embedded hardware CRC submodule or by supplying a user-defined value. This is controlled by setting TX_OPER_CTRL_LO.SW_CRC appropriately.

If hardware CRC generation is selected (TX_OPER_CTRL_LO.SW_CRC = 0, the default), the CRC is computed by hardware on the data and user data fields using the CRC polynomial $0x7 (x^8 + x^2 + x + 1)$. The transmitter module will automatically compute the CRC on the data fields without user intervention when the frame is transmitted. For more information on how the CRC is generated by the CRC Submodule, refer to [Section 7.4.8.3.7](#).

If software CRC generation is selected (TX_OPER_CTRL_LO.SW_CRC = 1), the CRC must be computed by software and placed in the TX_USER_CRC register. The next frame to be transmitted will use the value placed in the TX_USER_CRC register in place of the CRC value generated by the hardware.

As the TX_USER_CRC register is software-programmable, the application may use this field as an extra data field for application specific purposes. If TX_USER_CRC is used in this manner, the CRC detection on the receiver will not be valid and should be ignored.

7.4.8.3.2.7 Conditions in Which the Transmitter Must Undergo a Soft Reset

Unlike the receiver, there are no detectable errors that require a soft reset. A buffer overrun or underrun interrupt may or may not require a soft reset in order to resume proper operation. This determination is up to the application software. Refer to [Section 7.4.8.3.2.5](#) for more information on the transmit buffer.

7.4.8.3.2.8 Reset

The entire transmitter module and all transmitter registers are reset by SYSRSn. The transmitter core is reset by SYSRSn or by writing a 1 to TX_MAIN_CTRL.CORE_RST.

A module reset causes the registers to be reset to their default state.

7.4.8.3.3 FSI Receiver Module

The receiver module interfaces to the FSI clock (RXCLK), and data lines (RXD0 and RXD1) after they pass through an optional programmable delay line. The receiver core handles the data framing, CRC computation, and frame-related error checking. The receiver bit clock and state machine are run by the RXCLK input, which is asynchronous to the device system clock.

The receiver control registers allow the CPU to program, control, and monitor the operation of the FSI receiver. The receive data buffer is accessible by the CPU and the DMA.

The receiver core has the following features:

- 16-word data buffer
- Multiple supported frame types
- Ping frame watchdog
- Frame watchdog
- CRC calculation and comparison in hardware
- ECC detection
- Programmable delay line control on incoming signals
- DMA support
- FSI-SPI compatibility mode

Figure 7-234 provides a high-level overview of the internal modules present in the FSI receiver. Figure 7-235 shows a view of the FSI receiver core submodule. Not all data paths and internal connections are shown.

The following sections describe the various aspects of the FSI receiver module.

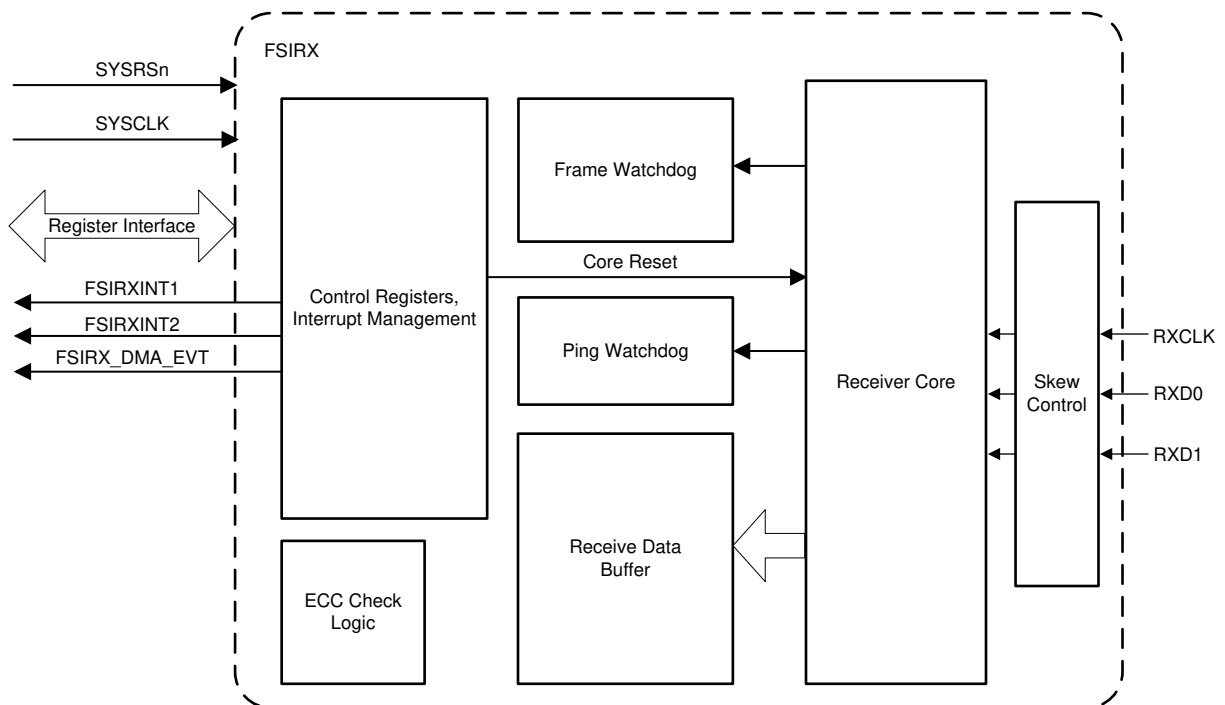

Figure 7-234. FSI Receiver Block Diagram

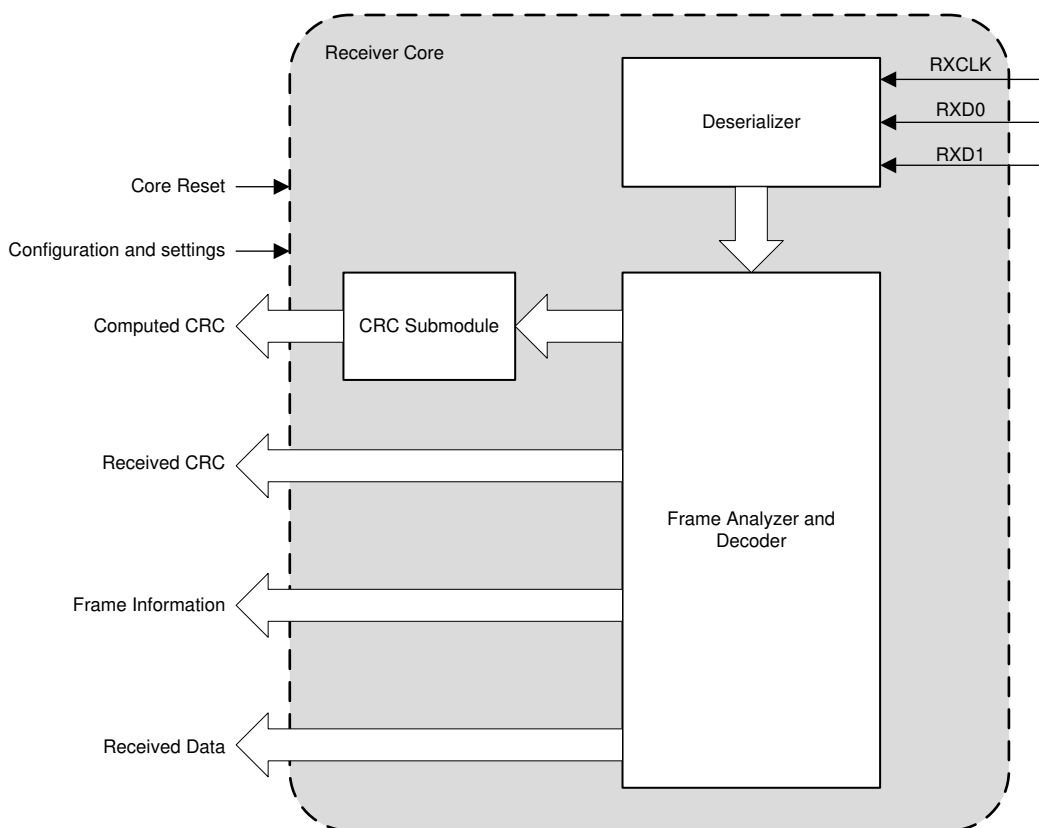

Figure 7-235. FSI Receiver Core Block Diagram

7.4.8.3.3.1 Initialization

On the first initialization or after a module reset following any frame error, the receiver module asserts and releases the receiver core reset bit (RX_MAIN_CTRL.CORE_RST) prior to any other initialization. Once the receiver module is initialized, the following steps are executed:

1. If required, assign interrupt sources to the necessary interrupt line.
2. If required, configure the ping watchdog to periodically check for an active link to the transmitter. See [Section 7.4.8.3.3.4](#) for configuration details.
3. If required, configure the frame watchdog to make sure that each frame is received within a predetermined window. See [Section 7.4.8.3.3.5](#) for configuration details.
4. Initialize the receive buffer pointer by writing to the RX_BUF_PTR_LOAD register. Received data is placed into the buffer starting with the address loaded in this register.
5. Make sure all errors and flags have been cleared from the RX_EVT_STS register.

At this point the receiver is ready to receive any incoming frames. Software can now either poll on the RX_EVT_STS register for various conditions. For example, when the RX_EVT_STS.FRAME_DONE and no other flags are set, the receiver has successfully received a frame without error.

Next, the application configures the various features such as the ping and frame watchdogs, DMA, external triggering, and so on. These features are described in subsequent sections. The receiver module is now ready to synchronize with the transmitter then begin reception. The synchronization sequence is described in [Section 7.4.8.4.1](#).

7.4.8.3.3.2 FSI_RX Clocking

The receiver module registers and control logic are clocked by the device system clock (SYSCLK). The receiver state machine is clocked by the receiver input clock pin (RXCLK).

CAUTION

RXCLK should never be faster than SYSCLK.

7.4.8.3.3.3 Receiving Frames

Once the receiver has been properly configured and synchronized, incoming messages are handled as described below. It is important to note that there is no equivalent to a chip select signal to gate incoming data. Every valid clock edge will latch data into the receiver.

The header information of the received frame will be placed in their respective register fields.

- RX_FRAME_INFO.FRAME_TYPE will contain the received frame type.
- RX_FRAME_TAG_UDATA.FRAME_TAG will contain the received frame tag.
- RX_FRAME_TAG_UDATA.USER_DATA will contain the received user data.

If any error conditions occur during reception such as a CRC mismatch, frame error, frame timeout, buffer overrun, or ping watchdog timeout, the corresponding flag will be set in the RX_EVT_STS register.

Note

If at any point during operation a frame error occurs, the receiver module must be reset and re-synchronized with the transmitter before the next frame can be successfully received. The follow errors are classified as frame errors:

- Type error
- CRC error
- End of frame error

7.4.8.3.3.3.1 Receiving Frames with DMA

The FSI receiver can continuously receive data and move it from the receiver buffer with the DMA. A DMA trigger will be generated every time a data frame has been received. This is concurrent with the FRAME_DONE signal that sets the RX_EVT_STS.FRAME_DONE flag. In order to receive continuous data with the DMA, some configurations need to be made on the receiver.

First, set RX_DMA_CTRL.DMA_EVT_EN to 1. This will allow the DMA trigger to propagate to the DMA module. The receiver is now able to trigger a DMA event upon the reception of a data frame.

The DMA must also be configured properly for the FSI to receive the data. One possible solution for using the receiver to continuously feed the DMA is show below:

- Set up two DMA channels to be triggered by the FSI Receiver DMA Trigger.
- Configure one DMA channel to copy data from the receive buffer to a larger data buffer.
- Configure the next DMA channel to copy the received frame tag and user data to another data buffer.
- Since the FSI receive buffer is a 16-word circular buffer, ensure the DMA channel servicing the data buffer wraps after 16 words are copied.

Unlike the transmitter, there is no requirement to have the DMA channel which is handling the data buffer, execute before the DMA channel handling the received tag and user data.

7.4.8.3.3.4 Ping Frame Watchdog

The ping frame watchdog is a hardware-enabled automatic error detection of the connection status to the transmitter. This watchdog monitors the time elapsed between ping frames. If the transmitter has been set up to periodically send out a ping frame, the receiver can be set up to monitor whether this frame has been received within a specified amount of time. If the time between ping frames has exceeded the programmed number of clock cycles, an event will be triggered which can generate an interrupt or be monitored by software.

This watchdog has a dedicated counter which is reset and restarted upon the successful reception of a ping frame. The watchdog counter will be incremented at the rate of SYSCLK. Optionally, the watchdog can be configured to be reset upon the successful reception of any frame. This option allows the receiver to monitor for any successful frame to indicate that the connection is still alive and the transmitter is still functioning as expected.

To configure the ping frame watchdog for operation:

1. Reset the ping watchdog counter by setting `RX_PING_WD_CTRL.PING_WD_RST` to 1 and then subsequently clearing it to 0.
2. Set `RX_OPER_CTRL.PING_WD_RST_MODE` to the desired watchdog reset event, either 0 for ping frames only, or 1 for any frame.
3. Set `RX_PING_WD_REF` to the maximum time between frames. Add 10 additional SYSCLK cycles to account for clock synchronization.
4. Enable the ping watchdog by setting `RX_PING_WD_CTRL.PING_EN` to 1.

The ping watchdog is now enabled and can now monitor for ping frames.

If the `RX_PING_WD_CNT` value reaches the value programmed in `RX_PING_WD_REF`, the `RX_EVT_STS.PING_WD_TO` flag will be set. If configured, an interrupt can be generated on this event.

7.4.8.3.3.5 Frame Watchdog

The frame watchdog is an additional feature the receiver can use to monitor for any error conditions. This dedicated watchdog monitors the duration that it takes for a single frame to be received. The watchdog starts incrementing at the time the receiver detects a proper start of frame condition. If the end of frame condition is not detected within the expected number of SYSCLK cycles, the frame watchdog will be triggered which can generate an interrupt or be monitored by software.

This watchdog is automatically started and stopped at the start-of-frame and end-of-frame conditions respectively. The frame watchdog is connected to SYSCLK.

To configure the frame watchdog for operation:

1. Reset the frame watchdog counter by setting `RX_FRAME_WD_CTRL.FRAME_WD_CNT_RST` to 1 and then subsequently clearing it to 0.
2. Set `RX_FRAME_WD_REF.FRAME_WD_REF` to the maximum number of SYSCLK cycles expected to be in the longest frame that may be received. Add an additional 10 SYSCLK cycles to account for clock synchronization.
3. Enable the frame watchdog by setting `RX_FRAME_WD_CTRL.FRAME_WD_CNT_EN` to 1.

The frame watchdog is now enabled and can detect a failed frame.

If the `RX_FRAME_WD_CNT` reaches the value programmed in `RX_FRAME_WD_REF`, the `RX_EVT_STS.FRAME_WD_TO` flag will be set. If enabled, an interrupt can be generated on this event.

If the frame watchdog interrupt ever occurs, the receiver core is in an invalid state to receive a new transmission. The only way to recover from a frame watchdog time out is to undergo a soft reset, and subsequently resynchronizing with the transmitter.

7.4.8.3.3.6 Delay Line Control

The receiver module has a programmable delay line on each of the external signal inputs: RXCLK, RXD0, and RXD1. The delay elements introduce delays on the respective lines. This is to facilitate adjustment for signal delays introduced by system level components such as signal buffers, ferrite beads, isolators, and so on, or board delays such as uneven trace lengths, long cable length, and so on. The length of the delay is controlled by setting the RX_DLY_LINE_CTRL register values for each line. By default, no delay is introduced by the delay line elements. The delay values should only be adjusted while the FSIRX is held in soft reset, ensuring that there are no active transmissions during this process. Figure 7-236 shows a representation of the delay line circuitry for the input signals. The implementation for RXCLK, RXD0, and RXD1 are replicas of this diagram. All circuits will behave similarly.

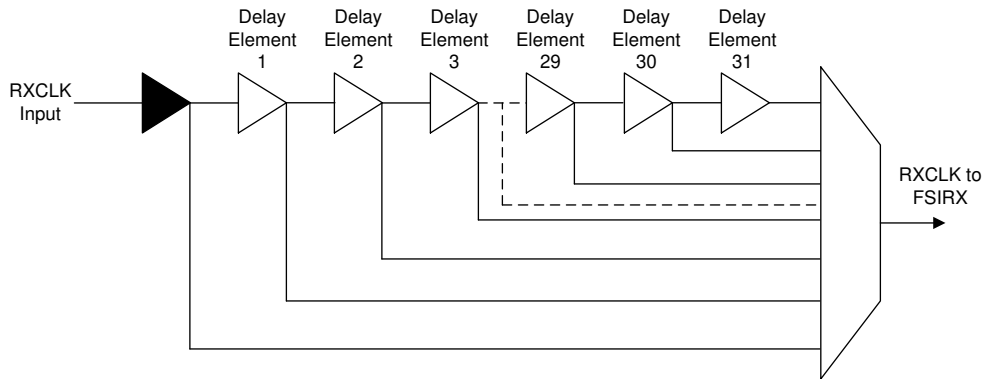

Figure 7-236. Delay Line Control Circuit

For more information on skew compensation, refer to [Fast Serial Interface \(FSI\) Skew Compensation](#).

7.4.8.3.3.7 Buffer Management

The FSI receiver has a 16-word buffer into which the data is copied to when it has been received. This buffer is implemented as a circular buffer, not a FIFO, so some care must be taken to properly interpret buffer overrun and underrun as well as the RX_BUF_PTR_STS register. These flags and pointers work under the assumption that the software or DMA is using the buffer as a circular buffer. If the receiver state machine enters into an erroneous state, there is no way for software to cleanly handle this because there is no guaranteed receive clock. For the receiver to detect a clean resynchronization, the state machine needs to be operational and not in the error state. The only way to recover from the error state is to reset the entire receiver module. For overrun and underrun, the receiver can no longer guarantee which values in the buffer are valid. As such, the best way to recover is to reset the FSI and resynchronize with the transmitter.

Due to the flexibility of the receive buffer, it is possible for software to implement a simple ping-pong buffer, or to randomly receive and read from any location of the buffer. If the buffer is used in this manner, these flags and status fields may be ignored without adversely affecting the receiver capability. Additionally, the CURR_WORD_CNT will also be invalid if used in this way. The application can set the buffer pointer manually by writing the 4-bit index to RX_BUF_PTR_LOAD. This will force the receiver to start storing the received data starting at the indicated location in the buffer.

7.4.8.3.3.8 CRC Submodule

The receive module will automatically calculate the CRC on the incoming data. The received CRC value is placed into `RX_CRC_INFO.RX_CRC`. The CRC value calculated by hardware on the received data is placed into `RX_CRC_INFO.CALC_CRC`. These values are compared by hardware and will set `RX_EVT_STS.CRC_ERROR` if there is a mismatch. The receiver can generate an interrupt based on `RX_EVT_STS.CRC_ERROR` if enabled.

Since the CRC is only used in data frames, the values found in `RX_CRC_INFO.RX_CRC` and `RX_CRC_INFO.CALC_CRC` are undefined during ping and error frames.

For more information on how the CRC is calculated, refer to [Section 7.4.8.3.7](#).

If the transmitting module is sending a software-defined CRC value (`FSITX.TX_OPER_CTRL_LO.SW_CRC = 1`) the receiver module will trigger a CRC Error event if the received value does not match the hardware-calculated value. As this is an application level decision, the FSIRX can safely disregard the CRC error event. Application software will need to calculate and verify the incoming CRC using the same custom algorithm used on the transmitter and act appropriately.

The CRC field may have also been used as an application-specific value, not a CRC, the application can use the `RX_CRC_INFO.RX_CRC` as required. All CRC errors and flags can be ignored in this situation.

7.4.8.3.3.9 Using the Zero Bits of the Receiver Tag Registers

The receiver tag registers (receiver frame tag and user data (`RX_FRAME_TAG_UDATA`) register and receiver ping tag (`RX_PING_TAG`) register) have the Least Significant Bit is set to 0. The actual received tag is in the bit positions 4:1. The reason for this is to facilitate user software to create a table of functions which can be called depending on the tag value. A function pointer needs a 32-bit storage space and hence each successive pointer will be offset by 2. If the first pointer is at address x , then the second pointer will be at address $x+2$, the third at address $x+4$ and so on. By keeping the LSB 0, the five bits of the tag register (bits 4:0) can now be directly used as an index into a table of function pointers.

7.4.8.3.3.10 Conditions in Which the Receiver Must Undergo a Soft Reset

The receiver will receive data on every clock edge. While there are specific patterns which determine the a start of a frame, and denote the end of a frame, these patterns are able to occur at any point during normal operation inside of the frame. If there ever is a point at which the receiver fails to detect a successful frame, the module must be reset in order to ensure that subsequent frames are received properly.

When any of the following errors occur in a received frame, the receiver may be required to be reset and resynchronized with the transmitter:

- Frame type error
- End of frame error
- Ping frame watchdog timeout
- Frame watchdog timeout
- Receiver in an invalid state due to noisy clock

The receiver core status (`RX_VIS_1.RX_CORE_STS`) can be monitored to determine if it has entered into an error state requiring a soft reset in order to resume communication. Incorrect frame type and end of frame errors will always cause this bit to become set. A soft reset is required in these cases. A frame watchdog timeout will always require a reset due to the fact that the receiver state machine is still expecting more information when the watchdog timed out. `RX_CORE_STS` can be used to determine if a noise event was the cause of the failed frame. The ping frame watchdog also will not cause `RX_CORE_STS` to be set. Similar to the frame watchdog, a corrupt receiver may not be the reason for the ping frame to have timed out. The transmitter may have gone offline and never sent a ping frame. Alternately, during idle time, a noise event may have occurred, thereby putting the receiver into a corrupt state. As the receiver will be able to detect this during the ping frame watchdog timeout interrupt handler, this type of event will not be lost and the application can act appropriately.

As the receiver is clocked by `RXCLK`, not `SYSCLK`, a noisy clock or data line may cause some internal design constraints to be violated, putting the receiver core logic into undefined states. Ensure that the clock and data

lines satisfy the Electrical Characteristics and timing requirements of the FSI module found in the data manual for this device. Failure to do so may cause the receiver state machine to go into an unrecoverable error state. The receiver can only be recovered by undergoing a soft reset. To determine the state of the receiver core after an unexpected frame error, the application should check the receiver core status bit.

In addition to the above errors, buffer overrun or underrun may warrant a soft reset in order to resynchronize with the local application software. Refer to [Section 7.4.8.3.3.8](#) for more information on the receive buffers. The requirement of resetting the receiver due to overrun or underrun is up to the application.

After the receiver has been placed into soft reset, the application must notify the other device's transmitter to begin a new synchronization phase. The simplest way to achieve this is through a ping or error frame sent with a designated tag. If the application is not using the FSITX on the device with the detected error, some other method must be established. The other device should stop transmitting and begin a new synchronization phase.

7.4.8.3.3.11 FSI_RX Reset

The receiver module and the registers are reset by SYSRSn. The receiver core is reset by SYSRSn or by writing a 1 to RX_MAIN_CTRL.CORE_RST.

A module reset causes the registers to be reset to their default state. After a module reset, the receiver module must be re-initialized and the data link re-established.

7.4.8.3.4 Frame Format

The FSI module transmits and receives information in frames. Each frame will contain multiple phases where different information can be found. The number of phases as well as the total length of the frame will vary depending on the frame type being transmitted. Frames may be as short as 16 bits long for a ping or error frame or 288 bits long for a 16-word data frame.

In normal transmission mode, there are four preamble clock edges before the start of the frame and four post-frame clock edges (postamble). Data is transmitted on both edges of the clock (double data rate). The basic frame structure is shown below. Each phase of the frame (such as start-of-frame, frame type, and so on) will be transmitted with the most significant bit first. [Table 7-133](#) describes the basic frame structure used by the FSI and adapted according to which frame type is transmitted.

Table 7-133. Basic Frame Structure

Idle State	Preamble	Start of Frame	Frame Type	User Data	Data Words	CRC Byte	Frame Tag	End of Frame	Postamble	Idle State
	1111	1001	4 bits	8 bits	1-16 words	8 bits	4 bits	0110	1111	

The FSI also supports a FSI-SPI compatibility mode. The SPI compatible frame structure is similar to a standard FSI frame, but there are differences. Refer to [Section 7.4.8.3.10](#) for more information on how to configure and use the FSI-SPI compatibility mode.

Note

One word of the FSI refers to 16 bits.

The terms “frame” and “packet” can be used interchangeably to describe the signaling format of the FSI.

7.4.8.3.4.1 FSI Frame Phases

The different phases of the frame structure are described in detail.

- **Idle State:** During the idle state, the clock and data lines will be driven high, the inactive state.
- **Preamble:** The preamble phase contains four clock edges (or two complete clock pulses) with the data signals held in the high state. These clock edges serve to flush the receiver logic and prepare it for receiving a new frame. This phase is not present in SPI compatibility mode.
- **Start of Frame:** The start of frame phase contains two clock pulses with four bits, 1001, transmitted on the data lines.
- **Frame Type:** The frame type phase contains two clock pulses with the 4-bit frame type code being transmitted on the data lines. The different frame types are described in detail in [Section 7.4.8.3.4.2](#). The transmitter must set the TX_FRAME_CTRL.FRAME_TYPE field before transmitting a frame. The received frame type is stored in the RX_FRAME_INFO.FRAME_TYPE.
- **User Data:** The user data phase contains a fully user-configurable data field. There are no restrictions on how this field is used. This phase is only available in data frames. The user data to be transmitted is set by writing to TX_FRAME_TAG_UDATA.USER_DATA. The received user data is stored in RX_FRAME_TAG_UDATA.USER_DATA.
- **Data:** The data phase contains the data that is being transmitted. The data is pulled from the transmit buffer of the transmitter and will be placed in the receive buffer of the receiver. Word 0 is transmitted first. This phase is only present in data frames. Depending on the type of frame transmitted, this can contain anywhere between 1 and 16 words depending on the frame type selected. More information on data frames is found in [Section 7.4.8.3.4.2.3](#).
- **CRC Byte:** The CRC byte contains the CRC of the transmitted data. The value present in this phase can be sourced from either hardware or software based on the TX_OPER_CTRL_LO.SW_CRC bit. Refer to the module-specific section of the CRC Submodule for more information on the CRC is generated or used, for the transmitter and receiver modules respectively. The CRC byte is only present in data frames.
- **Frame Tag:** The frame tag contains the 4-bit user-defined frame tag. There are no restrictions on how this field is used in an application. The transmitter supplies this tag into the TX_FRAME_TAG_UDATA.FRAME_TAG bits for data frames. Ping frames use the tag defined in TX_PING_TAG.TAG. The receiver can access the received frame tag in RX_FRAME_TAG_UDATA.FRAME_TAG.
- **End of Frame:** The end of frame contains four clock edges with four bits, 0110, transmitted on the data lines.
- **Postamble:** The postamble contains four additional clock edges with the data lines held in the high state. After the postamble, the clock and data lines will be driven high, their inactive state. This phase is not present in FSI-SPI compatibility mode.

7.4.8.3.4.2 Frame Types

The FSI hardware can generate and handle many predefined frame types. The different frame types can be used by the application to signal different types of events or convey different information to the receiver. The different frame types influence which phases and data fields to include in the transmitted frames.

[Table 7-134](#) provides a short overview of the different frame types used by the FSI. Each frame type is described in more detail in the following subsections.

Table 7-134. Frame Types and Their 4-bit Codes

Frame Type	4-bit Frame Code	Description
PING	0000	This is the ping frame that can be sent either by software or automatically by hardware.
ERROR	1111	This should be used typically during error conditions or any condition where one side wants to signal the other side for attention. However, the user software is at liberty to use this for any purpose.
DATA_1_WORD	0100	1 word data packet (16 bits of data)
DATA_2_WORD	0101	2 word data packet (32 bits of data)
DATA_4_WORD	0110	4 word data packet (64 bits of data)
DATA_6_WORD	0111	6 word data packet (96 bits of data)
DATA_N_WORD	0011	N(1-16) word data packet where software has programmed the number of the data words in a designated register. Both transmitter and receiver modules should have the same value programmed.
Reserved	0001, 0010, and 1000-1110	Reserved

7.4.8.3.4.2.1 Ping Frames

Ping frames are one of the most basic frames that can be generated by the FSI. [Table 7-135](#) shows the structure of the ping frames.

Table 7-135. Ping Frame

Idle State	Preamble	SOF	Frame Type	Frame Tag	EOF	Postamble	Idle State
	1111	1001	0000	xxxx	0110	1111	

The ping frame type is always 0000. The frame tag is defined by the application. Separate frame tags exist for timer and software initiated ping frames. No data or CRC is transmitted in a ping frame.

The main purpose of the ping frame is to periodically send a notification to the receiver to ensure an active connection between the transmitter and receiver. The transmitter and receiver cores implement different features to allow the ping frame to operate as a line break detect feature.

On the transmitter, the ping frame is the only frame which can be set up and transmitted without any further software or DMA intervention. Ping frames can be transmitted by any (or all) of the three sources: automatic ping timer, software, or external triggers. See [Section 7.4.8.3.2.3.3](#) for information on how the transmitter configures and sends the ping frames.

The receiver has a ping watchdog that can detect if a ping frame has not been received in a predetermined window. This allows the receiver to know if the connection between it and the transmitter has been broken. See [Section 7.4.8.3.3.4](#) for information on how the receiver handles ping frames.

7.4.8.3.4.2.2 Error Frames

Error frames are similar to ping frames in that there are no data fields transmitted. Despite the naming of this frame as an “error frame,” the usage of it is up to the application, as no restrictions are placed on how and when this type of frame is transmitted. [Table 7-136](#) shows the structure of an error frame.

Table 7-136. Error Frame

Idle State	Preamble	SOF	Frame Type	Frame Tag	EOF	Postamble	Idle State
	1111	1001	1111	xxxx	0110	1111	

The structure of the error frame is the same as a ping frame. No data or CRC values are transmitted. The frame type is 1111 for all error frames, and the frame tag is defined by software in the TX_FRAME_TAG_UDATA register.

The receiver can detect if an error frame has been received based on the frame type field. Because of this, the receiver can read the incoming frame tag from the RX_FRAME_TAG_UDATA register and act on up to 16 different conditions.

7.4.8.3.4.2.3 Data Frames

Data frames are the most complex frames. As the name indicates, these frames are used to transfer data. [Table 7-137](#) shows the general structure of data frames.

Table 7-137. Data Frame

Idle State	Preamble	SOF	Frame Type	User Data	Data Words	CRC Byte	Frame Tag	EOF	Postamble	Idle State
	1111	1001	0xxx	xxxx xxxx	1-16 words	xxxx xxxx	xxxx	0110	1111	

The frame type field will reflect the 4-bit code of the frame type. A list of frame types can be seen in [Table 7-134](#). The number of the data words transmitted will be determined by the frame type chosen.

There are four fixed-length data frames supported by the frame type: 1 word, 2 words, 4 words, and 6 words.

Additionally, there is a user-defined data length frame type where the number of data words is fixed by software. Anywhere from 1 to 16 words can be transmitted in this frame type. This length must be configured in the N_WORDS field of the transmitter’s TX_FRAME_CTRL register and receiver’s RX_OPER_CTRL register.

7.4.8.3.4.3 Multi-Lane Transmission

The FSI is capable of transmitting and receiving data on two parallel data lines. When enabled, data bits are split between the data lines while the start of frame, frame type, frame tag, and end of frame fields are identical and complete on each line. The user data, data, and CRC fields are split between the data lines. Starting with the most-significant bit, the odd-numbered bits appear on D0 and even-numbered bits appear on D1.

In the following example, assume the following:

8-bit user data: u7u6u5u4u3u2u1u0

16-bit data: d15d14d13d12...d1d0

8-bit CRC: c7c6c5c4c3c2c1c0

Table 7-138. Multi-Lane Frame Format

Idle State	Preamble	SOF	Frame Type	User Data	Data Words	CRC Byte	Frame Tag	EOF	Postamble	Idle State
TXD0	1111	1001	0011	u7u5u3u1	d15d13...d1	c7c5c3c1	xxxx	0110	1111	
TXD1	1111	1001	0011	u6u4u2u0	d14d12...d0	c6c4c2c0	xxxx	0110	1111	

7.4.8.3.5 Flush Sequence

Every time there is a soft reset of the receiver, the receiver requires a flush sequence from the transmitter before it can receive and decode frames. The receiver core has an asynchronous reset mechanism which will allow the receive module to be reset even in the absence of the receive clocks. However, due to the design, this reset will be released synchronous to the receive clock (RXCLK). Thus, the receiver will require five full clock pulses to be able to come out of reset. Sending the flush pattern will ensure that these clock edges are received and any subsequent frames sent to the receiver will be correctly interpreted.

The flush sequence consists of a single toggle on both of the data lines as well as five consecutive pulses on the clock line.

If the FSI receiver is receiving data from a standard SPI, a data word of 0xFFFF from the SPI will have the same effect as a flush sequence.

Figure 7-237 shows a sample plot of the flush sequence.

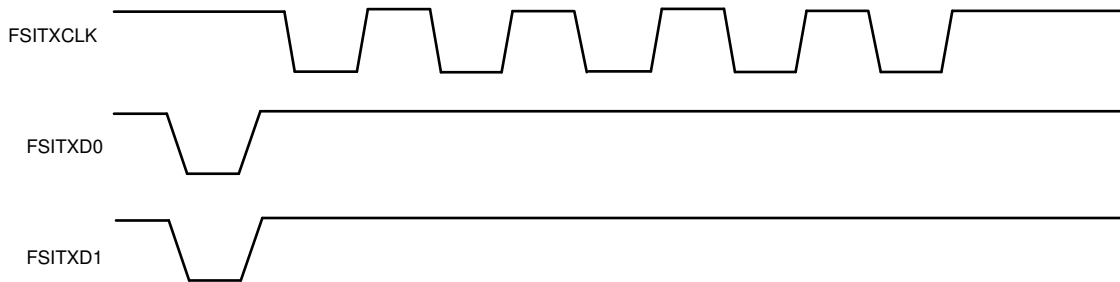

Figure 7-237. Flush Sequence Signals

7.4.8.3.6 Internal Loopback

The transmitter and receiver cores can be connected together internally to allow for development and debug. This is achieved by setting RX_MAIN_CTRL.INT_LOOPBACK to 1. Internal loopback routes the signals from the corresponding transmitter to the appropriate receiver pin. No configuration needs to be done in the transmitter.

Figure 7-238 shows the signal connections with internal loopback.

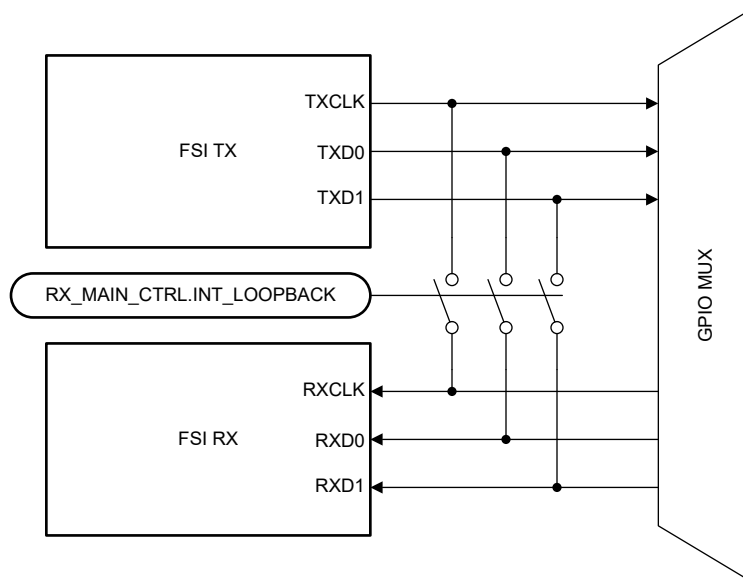

Figure 7-238. FSI with Internal Loopback

7.4.8.3.7 CRC Generation

The FSI uses CRC-8 with the polynomial 0x07 for the internal hardware CRC generation. This polynomial is also represented as x^8+x^2+x+1 .

For example, for a 2-word data packet the following calculation occurs:

Data-1 = 0x4433

Data-0 = 0x2211

User Data = 0xAA

The CRC is computed with the bytes being taken in the following order (first to last):

0xAA – Byte 0, User Data

0x11 – Byte 1, Data-0, Least-significant byte

0x22 – Byte 2, Data-0, Most-significant byte

0x33 – Byte 3, Data-1, Least-significant byte

0x44 – Byte 4, Data-1, Most-significant byte

7.4.8.3.8 ECC Module

The FSI module comes with a 16-bit or 32-bit ECC computation module in both the transmitter and receiver. Use of this module is optional.

Note that the ECC is independent and unrelated to the hardware CRC computation module present in both the transmitter and receiver cores.

The following example shows a scenario in which the application requires ECC be calculated and transmitted on a 2-word data frame.

In the FSITX module:

1. Configure the ECC module for 32-bit data by setting TX_OPER_CTRL_HI.ECC_SEL to 1.
2. Write the data to the TX_ECC_DATA register as well as the transmit buffer.
3. Read TX_ECC_VAL Register. This register contains the 8-bit ECC value calculated on the data.
4. Copy the 8-bit data from TX_ECC_VAL to TX_FRAME_TAG_UDATA.USER_DATA.
5. Set the Start Condition to begin the transmission.

The reverse process is followed on the FSIRX module. Once the data frame is received, user software can do the following:

1. Copy the data from the receive buffer to the RX_ECC_DATA register.
2. Copy the received user data that contains the transmitted ECC value from RX_FRAME_TAG_UDATA.USER_DATA to the RX_ECC_VAL register.
3. Read the RX_ECC_LOG register. This contains the result of the ECC computation using the RX_ECC_DATA and RX_ECC_VAL registers.
 - a. If no ECC errors were detected, RX_ECC_LOG is 0. The correct data is available in RX_ECC_SEC_DATA.
 - b. If a single bit error was detected, RX_ECC_LOG.SBE is 1. The autocorrected data is available in RX_ECC_SEC_DATA.
 - c. If multiple bit errors occurred, RX_ECC_LOG.MBE is 1. The data in RX_ECC_SEC_DATA is invalid and can not be used.

Using a 2-word data frame plus using the user data for the ECC is one possible implementation for ECC detection. Another option is to use a larger data frame a allocate one of the data words to be the ECC value.

7.4.8.3.9 FSI Trigger Generation

The RX_TRIGx external trigger can be used to initiate FSITX transmission. RX_TRIG0 must be used if TDM mode (multi-slave configuration) is required. RX_TRIG0 must be used as the trigger source for start of transmission while the programmable stretch width RX_TRIG0 signal is used as the SEL_TDM_PATH signal (which decides whether the local FSITX is active or put in bypass mode).

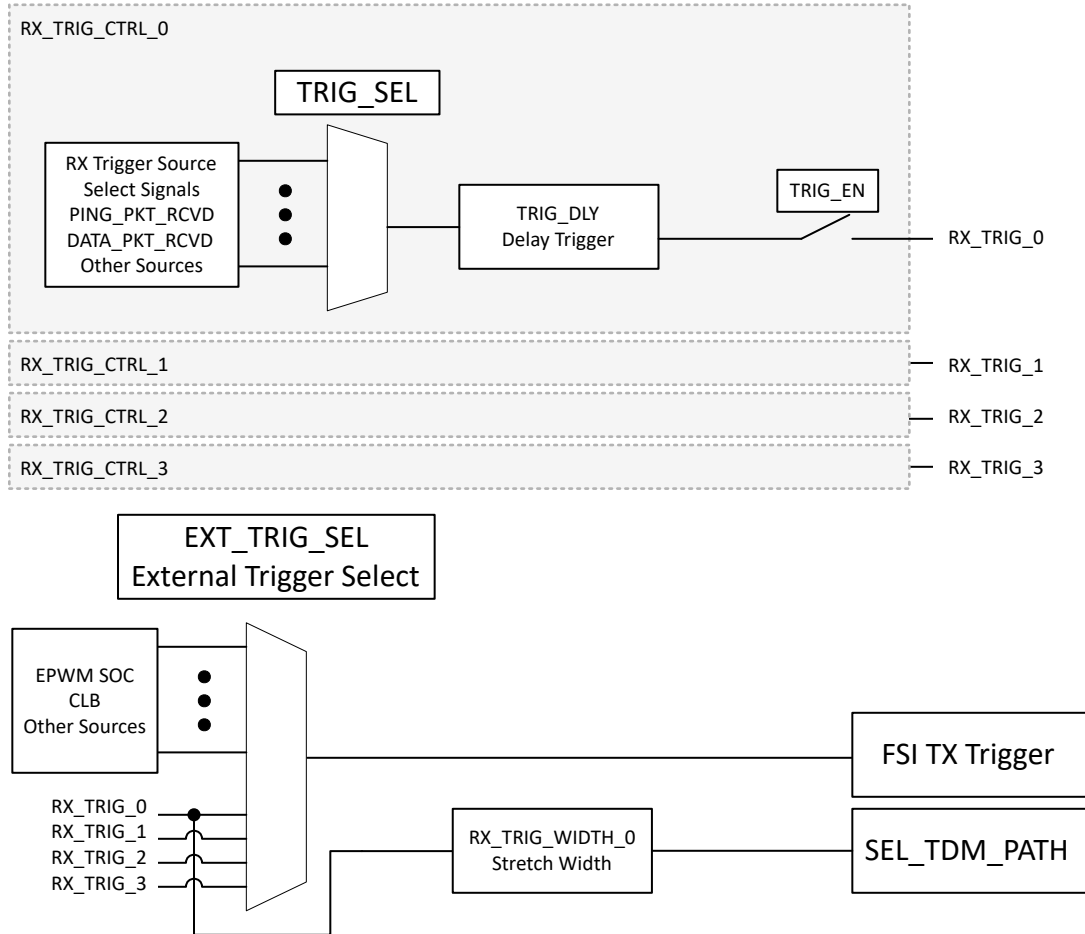

Figure 7-239. RX_TRIGx FSI Trigger

The signal source for the RX_TRIGx signal is selected through the RX_TRIG_CTRL_x.TRIG_SEL bits, as listed in Table 7-139.

Table 7-139. RX_TRIGx Trigger Select Signals

RX_TRIG_CTRLx.TRIG_SEL	Selected Signal
0	Ping Packet Received
1	Data Packet Received
2	Error Packet Received
3	Ping Frame Tag Match Occured
4	Data Frame Tag Match Occured
5	Error Frame Tag Match Occured
6	Frame Done
7	Reserved
8 to 15	Reserved

The RX_TRIGx signals can optionally be delayed (this can be used in TDM scenarios) through the RX_TRIG_CTRL_x.TRIG_DLY.

7.4.8.3.10 FSI-SPI Compatibility Mode

The FSI supports a SPI compatibility mode. While the FSI can communicate with a standard SPI module, the FSI supports a limited configuration. The features of this compatibility mode are:

- Data will transmit on rising edge and receive on falling edge of the clock.
- Only 16-bit word size is supported.
- TXD1 will be driven like an active-low, chip-select signal. The signal will be low for the duration for the full frame transmission.
- No receiver chip-select input is required. RXD1 is not used. Data is shifted into the receiver on every active clock edge.
- No preamble or postamble clocks will be transmitted. All signals return to the IDLE state after the frame phase is finished.
- It is not possible to transmit in the SPI peripheral configuration because the FSI TXCLK cannot take an external clock source.

Table 7-140 lists the frame structure of the FSI-SPI compatibility mode. Each frame phase is present in this mode. If the FSI is transmitting to a standard SPI module, the SPI must decode the frame structure. Similarly, if the FSI is configured as a SPI peripheral, the standard SPI must encode the transmission to be sent.

Table 7-140. FSI-SPI Compatibility Frame Structure

Idle State	Start of Frame	Frame Type	User Data	Data Words	CRC byte ⁽¹⁾	Frame Tag	End of Frame	Idle State
	1001	4 bits	8 bits	1-16 words	8 bits	4 bits	0110	

(1) The CRC byte is present only in data frames.

Because of the requirement that the standard SPI module encodes the various frame data, this limits the type of modules that can be connected to the FSI in SPI mode. The paired SPI module must have enough functionality to encode and decode the frames.

If the FSI is transmitted to a standard 16-bit SPI, the data would be arranged in the following manner. The example provided in Table 7-141 assumes a DATA_2_WORD frame has been sent.

Table 7-141. Contents of Data Received by a Standard SPI

SPI Data	Data Contents
SPI word 0	1001, 0100, 8-bit User Data
SPI word 1	Data word 1
SPI word 2	Data word 2
SPI word 3	8-bit CRC, 4-bit Frame Tag, 0110

7.4.8.3.10.1 Available SPI Modes

There are a few wiring schemes available for the FSI to use when communicating with an SPI module.

7.4.8.3.10.1.1 FSITX as SPI Controller, Transmit Only

The FSITX can operate as an independent SPI controller module. In this condition, TXCLK is connected to SPICLK, TXD0 is connected to SPIPICO, and TXD1 is connected to SPISTE, the chip select.

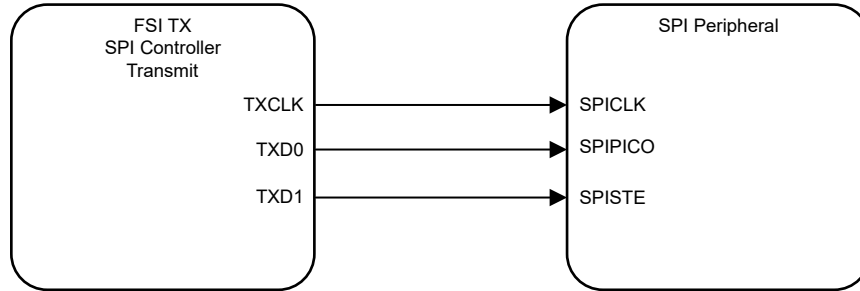

Figure 7-240. FSITX as SPI Controller, Transmit Only

When the FSI is an SPI transmitter, the application has the ability to check for frame errors, line breaks, CRC errors, and ECC checks on data. These are all encoded by hardware in every FSI frame. The SPI receiver requires some software to act upon this information.

Table 7-142. FSI as Controller Transmitter, SPI as Peripheral Receiver

Capability	Availability	Comment
Framing checks on the data frames	Yes	Can be implemented in software on the SPI receiver.
Ability to detect line breaks	Yes	Can be implemented in software on the SPI receiver but will require additional software overhead such as a timer, or watchdog.
CRC check	Yes	Can be implemented in software on the SPI receiver. For devices that have MCRC, this will be more efficient.
ECC on data	Yes	Can be implemented in software in the SPI receiver
Detection of abruptly terminated frames	No	
Double edge data rate	No	
Recovery from glitches on signal lines between frames	No	
Skew adjustment on signal lines	No	

7.4.8.3.10.1.1.1 Initialization

To configure the FSITX module to be an SPI controller for transmit only, proceed through the standard FSITX initialization procedure. Before releasing the FSITX from reset, set TX_OPER_CTRL_LO.SPI_MODE to 1. This enables the SPI clocking scheme and signaling structure.

7.4.8.3.10.1.1.2 Operation

The operation of the FSITX module in FSI-SPI Compatibility mode is the same as if the module is in standard FSI mode. The application can utilize the frame timer, ping frames, external frame triggers, and so on. Refer to [Section 7.4.8.3.2](#) for more information on each of these features.

7.4.8.3.10.1.2 FSIRX as SPI Peripheral, Receive Only

The FSIRX can operate as an independent SPI peripheral module. In this usage, RXCLK is connected to SPICLK and RXD0 is connected to SPIPICO. RXD1 is unused. There is no requirement for a chip select signal to be used when connected to the FSIRX. This is because the FSIRX responds to any incoming clock edge. If there is any noise or unwanted clock transitions, a flush sequence is required to resynchronize the FSIRX module with the controller.

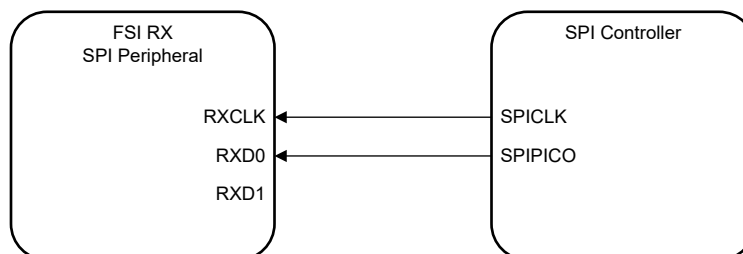

Figure 7-241. FSIRX as SPI Peripheral, Receive Only

When the FSI is an SPI receiver communicating with an SPI transmitter, the application has the ability to detect frame errors, line breaks, CRC errors, ECC checks on data, as well as abruptly terminated frames. Note that the FSI can handle all of this in hardware, but the SPI transmitter must encode the information into the data to be transmitted.

Table 7-143. SPI as Controller Transmitter, FSI as Peripheral Receiver

Capability	Availability	Comment
Framing checks on the data frames	Yes	Standard on FSI
Ability to detect line breaks	Yes	Can be implemented in software in the SPI transmitter. But will have to use some timer or watchdog in the transmitting SPI device
CRC check	Yes	Can be implemented in software in the SPI transmitter.
ECC on data	Yes	Can be implemented in software in the SPI transmitter.
Detection of abruptly terminated frames	Yes	This is accomplished with the FSI setting up the frame watchdog counter.
Double edge data rate	No	
Recovery from glitches on signal lines between frames	Yes	Whenever glitches occur on either the clock or data lines in between transmissions, the initial flush pattern of a frame will discard the effects of these glitches and will cause the receiver to resynchronize when the real "start-of-frame" pattern is seen. So, the ability to reject glitches in between frames is very high.
Skew adjustment on signal lines	Yes	The FSI receiver has the ability to add delays to the incoming signal lines.

7.4.8.3.10.1.2.1 Initialization

To configure the FSIRX module to be an SPI peripheral for receiving only, proceed through the standard FSIRX initialization procedure. Before releasing the FSIRX from reset, set `RX_OPER_CTRL.SPI_MODE` to 1. This enables the SPI clocking scheme and signaling structure.

7.4.8.3.10.1.2.2 Operation

The operation of the FSIRX module in FSI-SPI compatibility mode is the same as if the module is in standard FSI mode. The application can utilize the Frame and Ping Watchdogs, CRC and ECC checks, and so on. Refer to [Section 7.4.8.3.3](#) for more information on each of these features.

7.4.8.3.10.1.3 FSITX and FSIRX Emulating a Full Duplex SPI Controller

In this configuration, the FSITX is the controller clock. The FSITX module drives TXCLK (SPICLK), TXD0 (SPIPICO), and TXD1 (SPISTE/chip select) to the SPI peripheral. The SPIPOCI signal is connected back to the RXD0 signal. RXCLK can be applied either using the internal SPI pairing feature or externally wired, depending on the application requirements. Since the FSITX and RX modules are independent, the FSIRX could also be thought of as an additional SPI peripheral. Some software logic is required in order for the FSI to emulate an SPI controller fully.

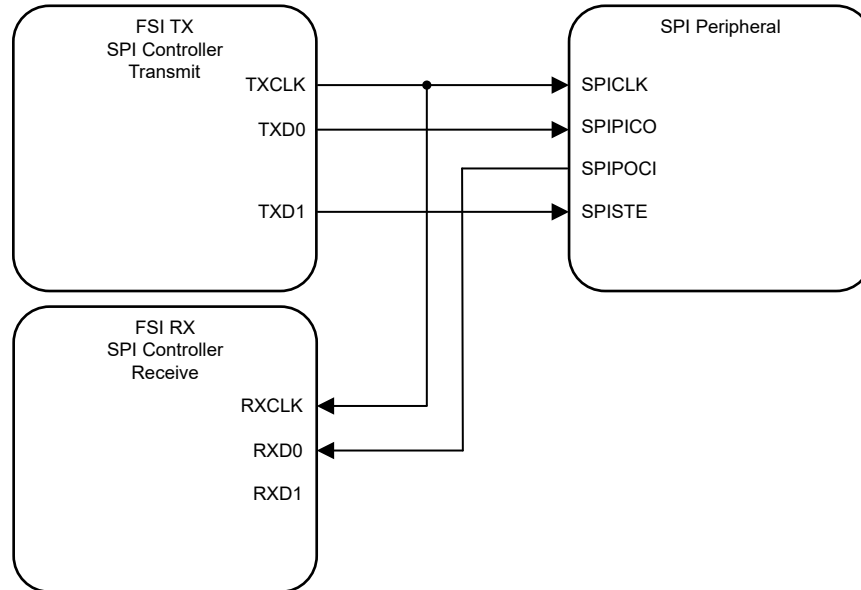

Figure 7-242. FSITX and FSIRX as SPI Controller, Full Duplex

7.4.8.3.10.1.3.1 Initialization

To configure both FSITX and RX modules for full duplex SPI controller operation, follow the initialization instructions for each module described in the preceding sections. Both FSITX and RX modules must set their respective SPI_MODE bits. This will enable the SPI clocking scheme and signaling structures.

If internal clock loopback is desired, the FSIRX module must also set RX_MAIN_CTRL.SPI_PAIRING to 1. This internally connects TXCLK to RXCLK. If using internal clock loopback, the GPIO used for RXCLK can be reallocated to other application requirements.

If the application requires an external clock loopback, make sure that TXCLK is connected to RXCLK. This is required if the SPI peripheral is across an isolation barrier and there is latency between TXCLK being launched and SPIPOCI data being received on RXD0.

7.4.8.3.10.1.3.2 Operation

In this mode of operation, some higher level software must be written to emulate a full SPI controller module. There is no path for the transmit module to determine what the receive module received. Both the TX and RX modules are still able to utilize the various other features available, such as the ping frame timer, ping frame and frame watchdogs, CRC and ECC error checkers, and so on. The procedure for configuring these features is described elsewhere in this document.

7.4.8.4 FSI Programming Guide

This section describes various operational sequences and features for the FSI.

7.4.8.4.1 Establishing the Communication Link

Once the transmitter and receiver modules have been configured, some synchronization must occur before the modules exchange data. Since the receiver accepts data on any clock transition, the receiver core logic must be flushed to properly interpret the start of a new, valid frame. This is especially true when the FSI modules reside on separate devices and are possibly isolated.

The following example provides a suggested approach for establishing a clean communication link on two separate devices that power up in an arbitrary order. Note that this is only a sample synchronization. Depending on application requirements, a different approach can be followed. The single, most important aspect of synchronization is to make sure that the receiver is properly flushed and ready to receive a complete frame without error. How to achieve this is up to the application.

Figure 7-243 shows the connection of the devices in this example. While there is no true concept of a main device or a remote device node in the FSI protocol, the example uses this nomenclature as a simple way to describe the data flow.

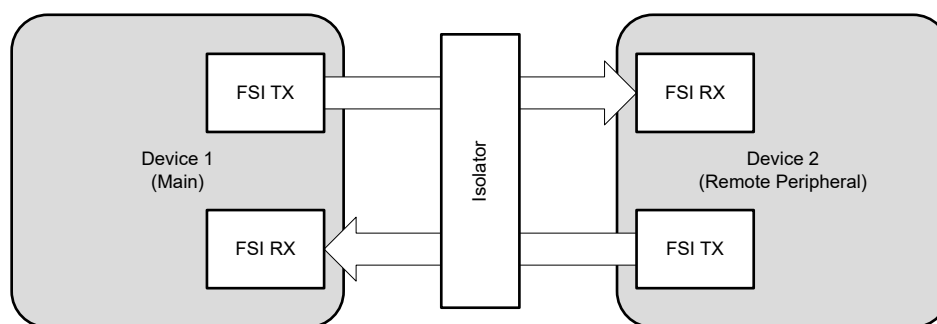

Figure 7-243. Point to Point Connection

Device 1 is the main node; it is the driver of the initialization sequence. Device 2 is the remote node; it responds to the main device commands. In this example, as well as in a real world use-case, neither the main device nor the remote device knows precisely when the other is ready to receive communication.

Sample sequences for both the main device and remote device are provided in the following subsections.

7.4.8.4.1.1 Establishing the Communication Link from the Main Device

The following sequence is an example of how the main device node establishes the communication link with the remote device without external signals outside of the standard communication link.

1. Assert the core reset to both the FSITX and FSIRX modules, and then deassert the resets.
2. Configure the transmitter and receiver for desired operation.
3. Set up the receiver interrupts to detect an incoming transmission.
4. Begin the ping loop:
 - Send the flush sequence.
 - Send a ping frame with the frame tag 0000.
 - Wait for some time. (determined by application)
 - If the FSIRX has received a valid ping frame, continue; else iterate the loop again.
 - If the received ping frame tag was 0001, continue; else iterate the loop again.
5. Send a ping frame with the frame tag 0001.

At this point, both the main transmit and receive channels have successfully received a frame from their remote counterparts. The link has been established and standard application communication may begin.

7.4.8.4.1.2 Establishing the Communication Link from the Remote Device

The following sequence is an example of how the remote device node establishes the communication link with the main device without external signals outside of the standard communication link.

1. Apply the core reset to both the FSITX and FSIRX modules, and then release the reset.
2. Configure the transmitter and receiver for desired operation.
3. Set up the receiver interrupts to detect an incoming transmission.
4. Wait for a receiver interrupt.
5. If the FSIRX has received a valid ping frame, continue; else return to step 4.
6. If the received frame tag was 0000, continue; else discard the transmission and return to step 4.
7. Send the flush sequence.
8. Send a ping frame with the frame tag 0001.
9. Wait for a receiver interrupt.
10. If the FSIRX has received a valid ping frame, continue; else return to step 4.
11. If the received ping frame tag was 0001, continue; else if the received frame tag was 0000, return to step 9.
This can happen if a second ping frame was already in transit before receiving the remote device response in step 8.

At this point, both the transmit and receive modules have successfully received ping frames from their main counterparts. The link has been established and regular communication may now proceed. The application may configure periodic ping frames from the transmitter, initialize the receiver ping and frame watchdogs, and begin the communication required by the application.

7.4.8.4.2 Register Protection

Both the FSITX and FSIRX modules contain control registers that have embedded write protection. This is accomplished through register keys and a main register lock. These protections make sure that no spurious writes or unintentional modifications to these registers are accepted. .

Register Key Protection

Some bits in the FSI registers are protected by a key. To write to these bits, the key must be written at the same time. For example, to put the transmitter core into reset, TX_MAIN_CTRL.CORE_RST must be set. To do this, write 0xA501 to TX_MAIN_CTRL, where 0xA500 is the KEY value, and 0x0001 is the CORE_RST value. Refer to the *Registers* section for more information on which registers have write keys added.

Control Register Lock Protection

There also exists a main lock to prevent any modifications to the control registers. There is an independent lock for each FSI module. For the list of registers that are protected by this control register lock, refer to the *Registers* section. The control register lock prevents any writes to the control registers until the lock is released. To set the control register lock, write 0xA501 to RX_LOCK_CTRL and TX_LOCK_CTRL for the receiver and transmitter, respectively.

The control register lock cannot be disabled by the application until a SYSRSn has been asserted. This can occur at the device level, or by writing to the appropriate peripheral soft reset register (DEV_CFG_REGS.SOFTPRESx) for the FSI module.

7.4.8.4.3 Emulation Mode

There is no specific emulation mode or configuration supported. The FSI cores will always be in free running mode. CPU halts will not have any effect on the operation of the FSI. However, reads of registers and data buffers by the debugger will not affect any flags, or status of the data buffers.

If you want to stop the operation of either FSI module when the debugger halts, the following steps are required:

1. Set the debugger to real-time emulation mode.
2. Mark the FSI interrupt group as a time-critical interrupt. That is, enable the corresponding bit in the DBGIER register.
3. The ISR can check the DSTAT register and to determine if the ISR was called when the debugger was halted.
4. FSI operations can be disabled and the ISR can branch to a debug-specific halt location.

7.4.9 Sigma Delta Filter Module (SDFM)

The sigma delta filter module (SDFM) is a four-channel digital filter designed specifically for current measurement and resolver position decoding in motor control applications. Each input channel can receive an independent delta-sigma ($\Delta\Sigma$) modulator bit stream. The bit streams are processed by four individually-programmable digital decimation filters. The filter set includes a fast comparator (secondary filter) for immediate digital threshold comparisons for over-current and under-current monitoring, and zeros crossing detection.

7.4.9.1 Introduction.....	672
7.4.9.2 SDFM Integration.....	676
7.4.9.3 Configuring Device Pins.....	678
7.4.9.4 Input Qualification.....	679
7.4.9.5 Input Control Unit.....	680
7.4.9.6 SDFM Clock Control.....	680
7.4.9.7 Sinc Filter.....	682
7.4.9.8 Data (Primary) Filter Unit.....	684
7.4.9.9 Comparator (Secondary) Filter Unit.....	690
7.4.9.10 Theoretical SDFM Filter Output.....	694
7.4.9.11 Interrupt Unit.....	696

7.4.9.1 Introduction

Figure 7-244 shows the SDFM CPU Interface.

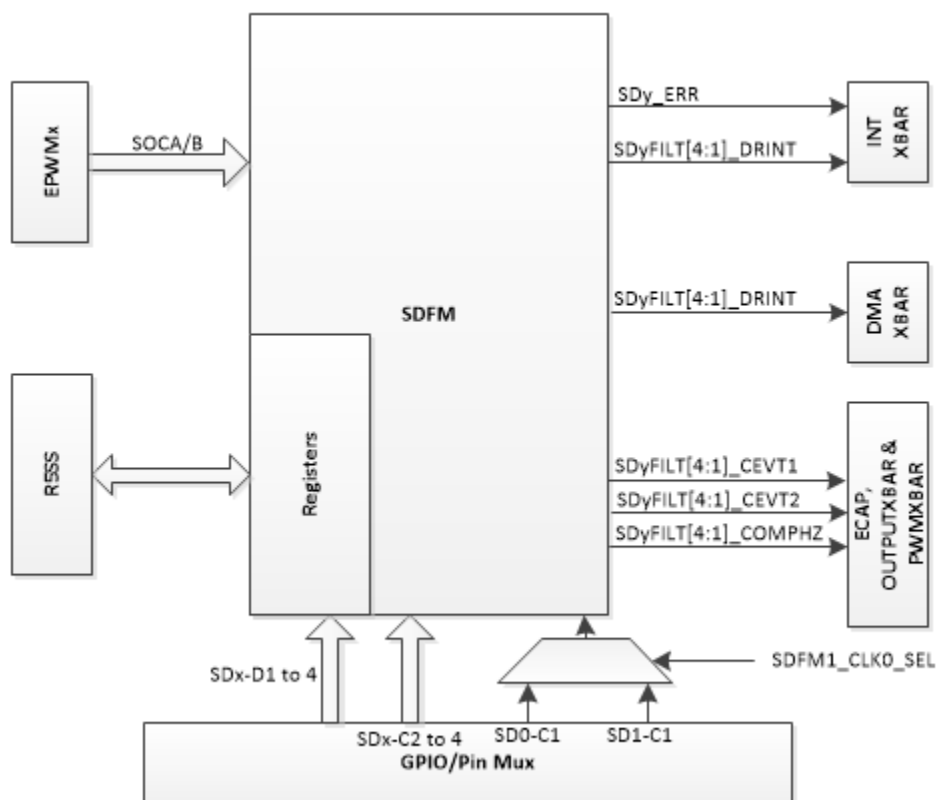

Figure 7-244. Sigma Delta Filter Module (SDFM) CPU Interface

Note

SDFM1_CLK0_SEL signal is controlled by register in Global Control Register Space

7.4.9.1.1 Features

SDFM features include:

- Eight external pins per SDFM module
 - Four sigma-delta data input pins per SDFM module (SD-Dx, where x = 1 to 4)
 - Four sigma-delta clock input pins per SDFM module (SD-Cx, where x = 1 to 4)
- Different configurable modulator clock modes supported:
 - Mode 0: Modulator clock rate equals the modulator data rate.
- Four independent, configurable secondary filter (comparator) units per SDFM module:
 - Four different filter type selection (Sinc1/Sinc2/SincFast/Sinc3) options available
 - Ability to detect over-value condition, under-value condition, and Threshold-crossing conditions
 - OSR value for comparator filter unit (COSR) programmable from 1 to 32
- Four independent configurable primary filter (data filter) units per SDFM module:
 - Four different filter type selection (Sinc1/Sinc2/SincFast/Sinc3) options available
 - OSR value for data filter unit (DOSR) programmable from 1 to 256
 - Ability to enable or disable (or both) individual filter module

- Ability to synchronize all four independent filters of an SDFM module by using the Main Filter Enable (MFE) bit or by using PWM signals
- Data filter output can be represented in either 16 bits or 32 bits.
- Data filter unit has a programmable mode FIFO to reduce interrupt overhead. The FIFO has the following features:
 - The primary filter (data filter) has a 16-deep x 32-bit FIFO.
 - The FIFO can interrupt the CPU after programmable number of data-ready events.
 - FIFO Wait-for-Sync feature: Ability to ignore data-ready events until the PWM synchronization signal (SDSYNC) is received. Once the SDSYNC event is received, the FIFO is populated on every data-ready event.
 - Data filter output can be represented in either 16 bits or 32 bits.
- PWMx.SOCA/SOCB can be configured to serve as SDSYNC source on a per-data-filter-channel basis.
- PWMs can be used to generate a modulator clock for sigma-delta modulators.
- Configurable Input Qualification available for both SD-Cx and SD-Dx
- Ability to use one filter channel clock (SD-C1) to provide clock to other filter clock channels.
- Configurable digital filter available on comparator filter events to blankout comparator events caused by spurious noise

7.4.9.1.2 Block Diagram

Each SDFM module has four independent filter modules. These filter modules are identical and can be configured independently. Each individual filter module has the following units:

- Input control unit
- Primary filter (data filter) unit
- Secondary filter (comparator filter) unit with 4 independent comparators

Figure 7-245 shows the SDFM module block diagram. The SDFM port operation is configured and controlled by the registers listed in .

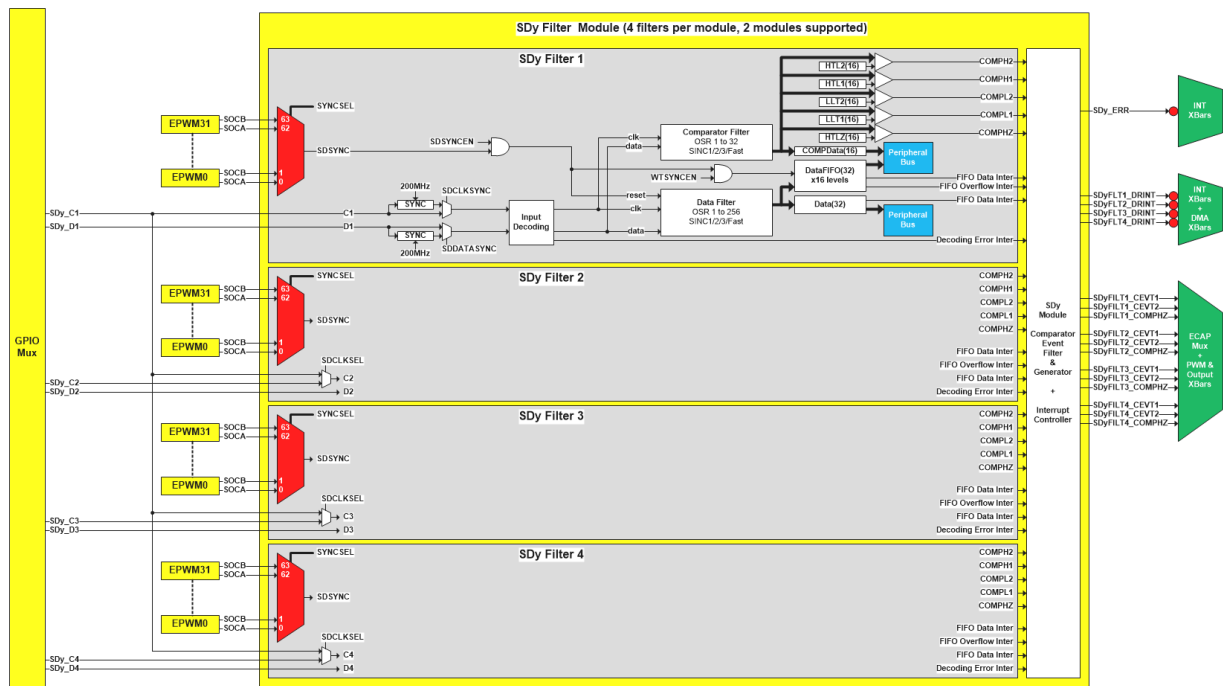

Figure 7-245. Sigma Delta Filter Module (SDFM) Block Diagram

Each filter module shown in Figure 7-246 has a primary (data) filter and a secondary (comparator) filter pair that receives the same bit stream. Except for the input bit stream, both the primary and secondary filter are completely independent of each other. Each of these filter modules can be independently configured. So, in a SDFM module, there is a total of four primary filters and four secondary filters.

ADVANCE INFORMATION

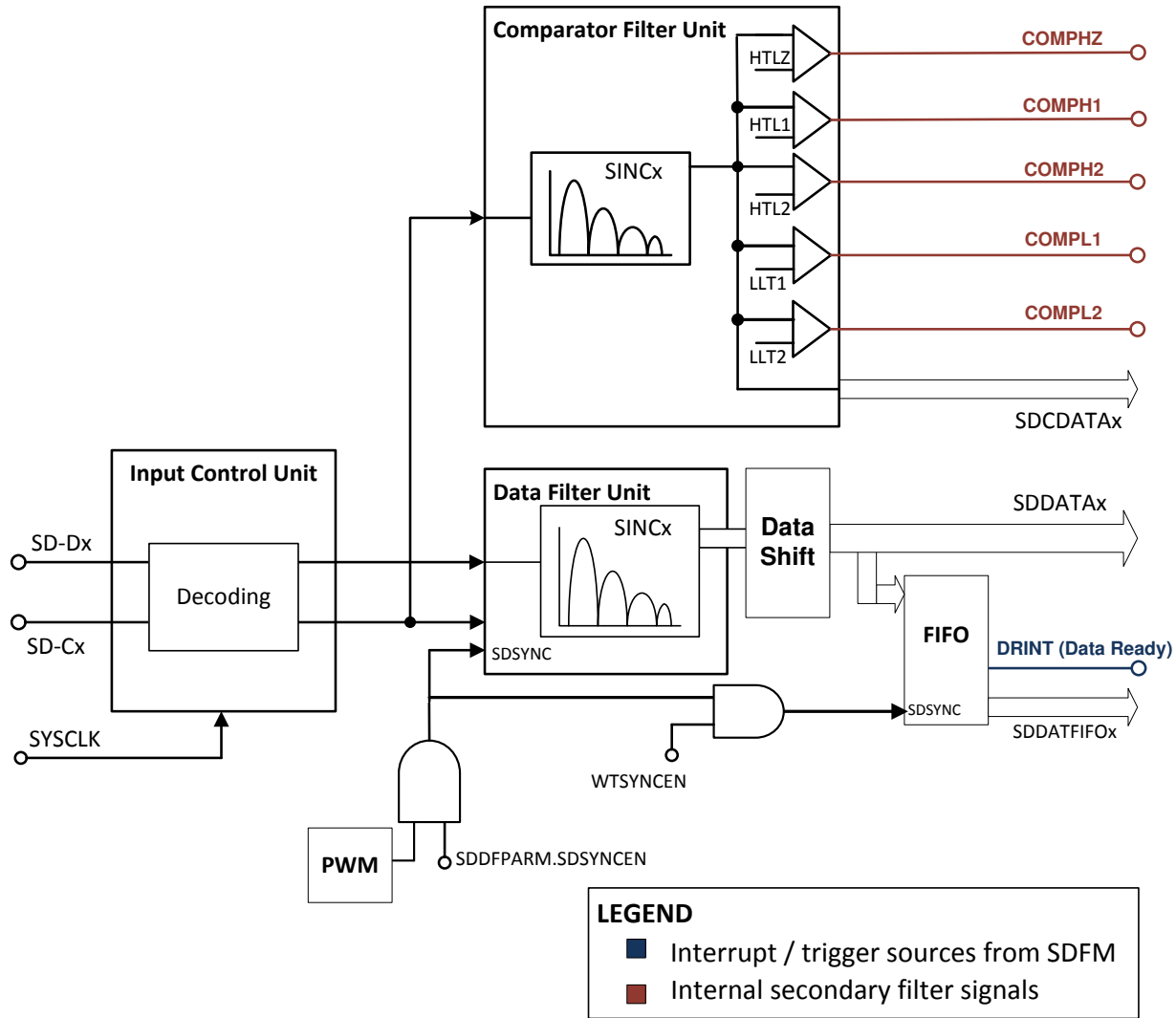

Figure 7-246. Block Diagram of One Filter Module

7.4.9.2 SDFM Integration

There are 4x SDFM modules integrated in the CONTROLSS. The diagram below provides a visual representation of the device integration details.

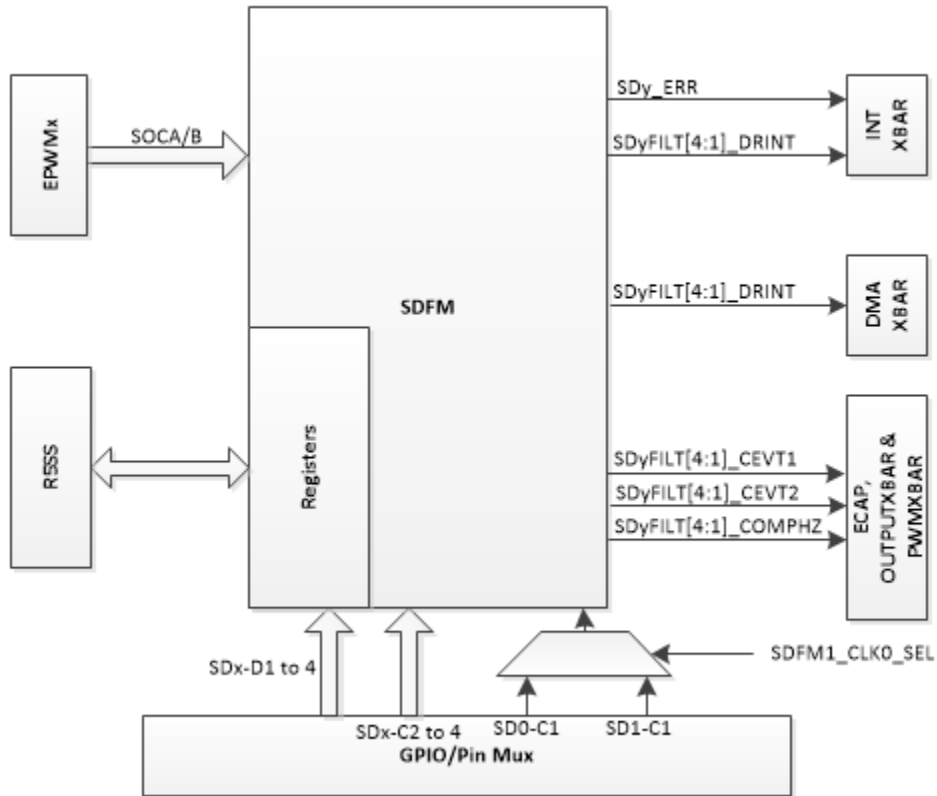
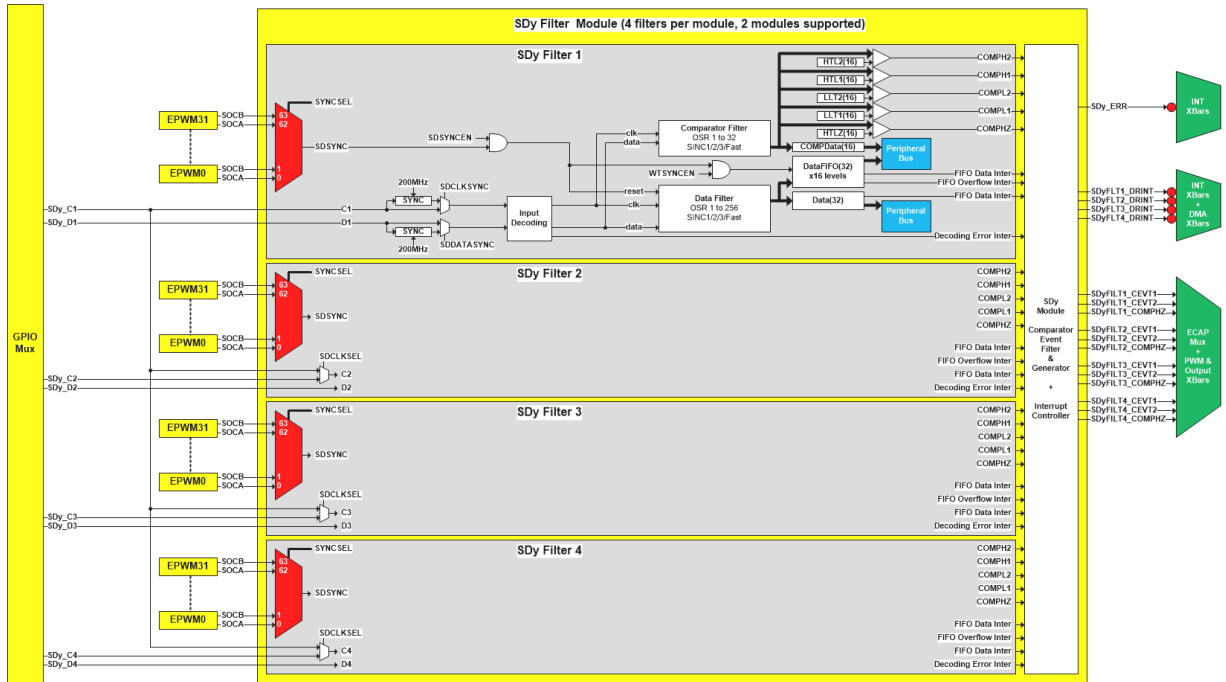

Figure 7-247. SDFM Integration Diagram (Simple)

ADVANCE INFORMATION



ADVANCE INFORMATION

7.4.9.3 Configuring Device Pins

The GPIO mux registers must be configured to connect this peripheral to the device pins. To avoid glitches on the pins, the GPyGMUX bits must be configured first (while keeping the corresponding GPyMUX bits at the default of zero), followed by writing the GPyMUX register to the desired value.

For proper SDFM operation, use the following GPIO input qualification. Other GPIO qualifications are not supported.

CAUTION

The SDFM clock inputs (SDx_Cy pins) directly clock the SDFM module. Any glitches or ringing noise on these inputs can corrupt the SDFM module operation. Special precautions should be taken on these signals to ensure a clean and noise-free signal that meets SDFM timing requirements. Precautions such as series termination for ringing due to any impedance mismatch of the clock driver and spacing of traces from other noisy signals are recommended.

Note

The SDFM module expects SD-Dx to change on the falling edge of SD-Cx and strobes for SD-Dx on the rising edge. But some SD-modulators in the market change SD-Dx on the rising edge and expect SDFM to strobe for data on the falling edge. In such cases, the GPIO inversion feature (GPxINV) is used on SD-Cx pin to change polarity and make it compatible with the SDFM.

See the *General-Purpose Input/Output (GPIO)* chapter for more details on GPIO mux and settings.

7.4.9.4 Input Qualification

Impulse noise sources such as EMI, crosstalk, and so on, has the possibility of corrupting SDCLK and SDDATA bit streams, resulting in corrupted SDFM filtered data. This impulse noise effects could be mitigated when using the input qualification feature which synchronizes SDCLK / SDDATA signals with PLLCLK. By default, both SDCLK and SDDATA bit stream are not synchronized. SDCLK can be synchronized to PLLCLK by setting SDCTLPARAMx.SDCLKSYNC = 1 and SDDATA can be synchronized to PLLCLK by setting SDCTLPARAMx.SDDATASYNC = 1. [Figure 7-249](#) shows optional Input Qualification option on SDCLK and SDDATA lines.

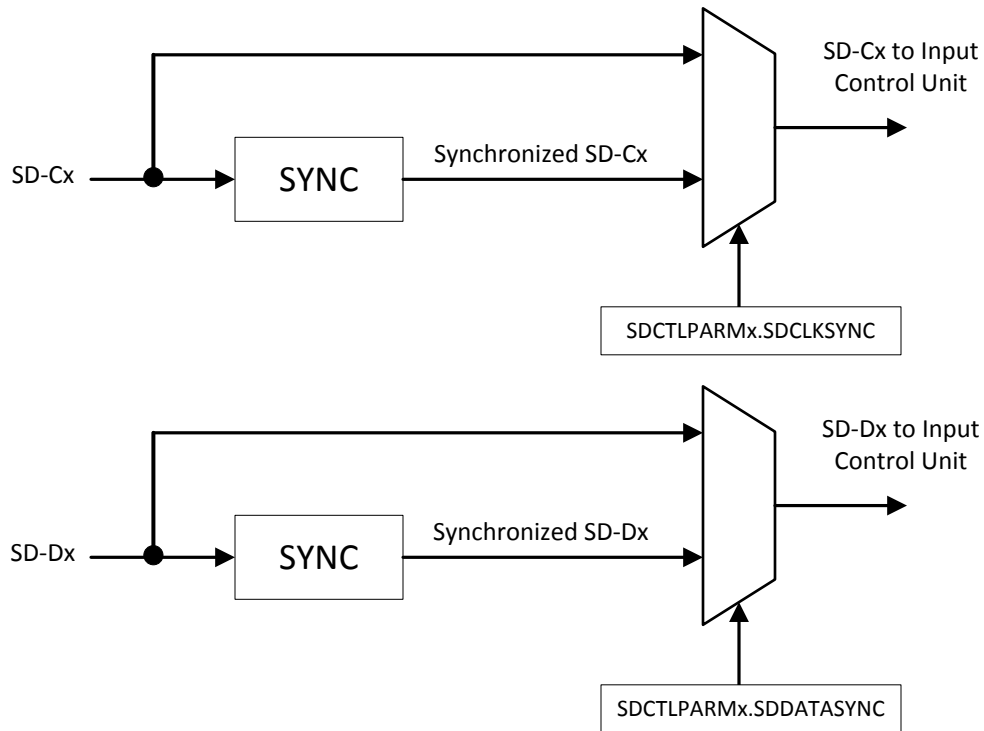

Figure 7-249. Input Qualification on SD-Cx and SD-Dx

Note

SDFM PLL clock needs to be configured in case synchronisers inside SDFM is used.

7.4.9.5 Input Control Unit

The input control unit receives sigma delta modulated data and a sigma delta modulated clock. The modulated data received is captured and passed on to the data filter unit and comparator unit. This unit can be configured to receive the modulated data in Mode 0. [Table 7-144](#) and [Figure 7-250](#) show how SDCTLPARMx.MOD bits can be configured in Mode 0.

Table 7-144. Modulator Clock Modes

Modulator Mode [MOD]	Description
0	The modulator clock is running with the modulator data rate. The modulator data is strobed at every rising edge of the modulator clock.
1	Reserved
2	Reserved
3	Reserved

Note

In order to achieve the maximum value, the sigma-delta modulator has to be operated at absolute maximum positive or negative full scale, which is outside of the recommended full scale range of 80% of most sigma-delta modulators.

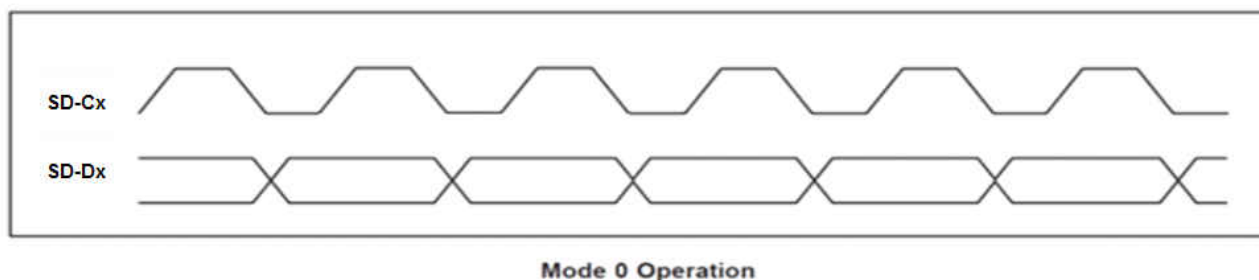
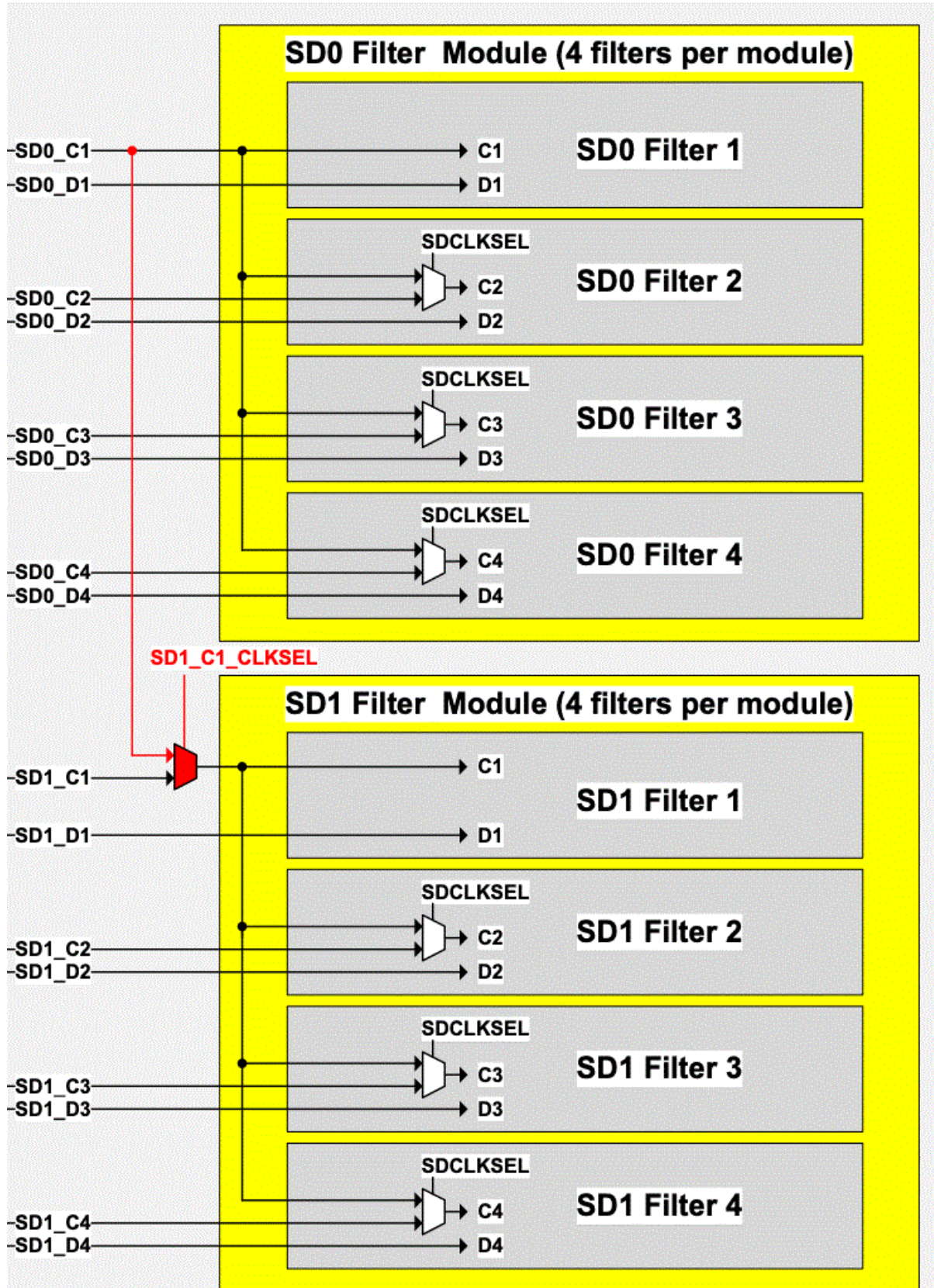

Figure 7-250. Different Modulator Modes Supported

7.4.9.6 SDFM Clock Control

In systems, the modulator clock can be generated using PWMs. Assuming all the SD-CLKs see the same delay on board traces, you can potentially use just one clock to clock multiple filters; thereby, saving on the number of pins used for SDFM. To enable this, Filter1 SDCLK (SD-C1) can possibly apply to other filter channels if required. The SDCTLPARAMx.SDCLKSEL register bit field can be configured to select filter channel SDCLK. It is also possible to drive SD0 FILTER1 clock from the pinmux to SD1 FILTER1 by configuring CONTROLSS_CTRL.SDFM1_CLK0_SEL. See [Figure 7-251](#) to view this feature.



ADVANCE INFORMATION

Figure 7-251. SDFM Clock Control

7.4.9.7 Sinc Filter

Both comparator filter and data filter available in SDFM have the Sinc^N filter as its core. The Sinc^N filter is essentially a low-pass filter that converts the input bit stream into digital data by digital filtering and decimation. This filtered digital data represents analog input given to the sigma delta modulator. Simplified Sinc^N architecture consists of cascaded integrators and differentiators separated by a down-sampler as shown in Figure 7-252. The Z-transfer function of the Sinc filter of order N is shown in Figure 7-253.

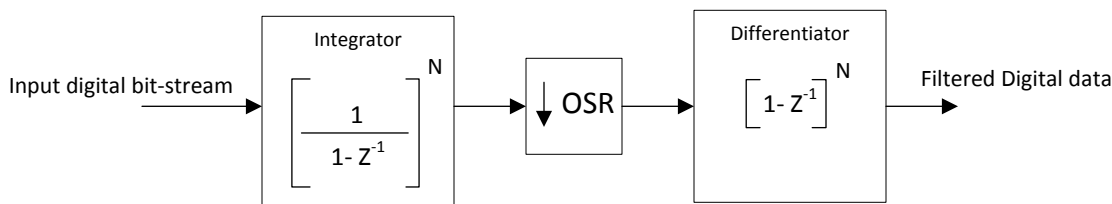

Figure 7-252. Simplified Sinc Filter Architecture

$$H(Z) = \left[\frac{1 - Z^{-OSR}}{1 - Z^{-1}} \right]^N$$

N = Order of Sinc filter
OSR = Over Sampling Ratio

Figure 7-253. Z-Transform of Sinc Filter of Order N

Effective resolution of the Sinc filter (ENOB) depends upon filter type, OSR and sigma-delta modulator frequency. Typically, higher resolution (or) ENOB can be achieved by higher OSR for a given filter type; however, the tradeoff is increased filter delay. It is important to choose the right sigma delta modulator by studying the optimal speed versus resolution tradeoff. Refer to the corresponding sigma delta modulator datasheet to determine the effective resolution for a given Sinc filter configuration. Figure 7-254 shows the frequency response of different filter structures when OSR = 32 and when the sigma delta modulator frequency is 10 MHz.

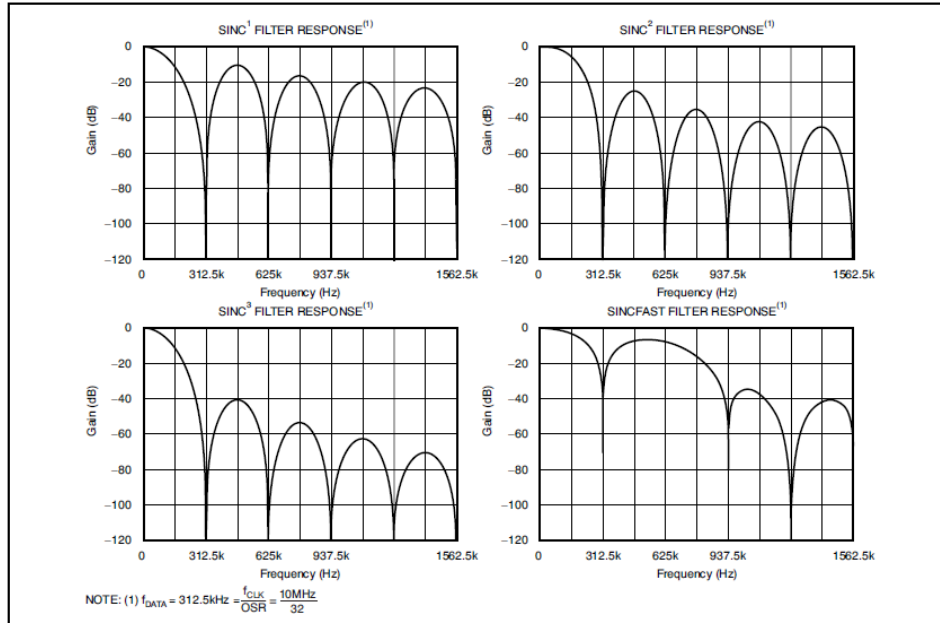

Figure 7-254. Frequency Response of Different Sinc Filters

The order of different sinc filter is shown in Table 7-145.

Table 7-145. Order of Sinc Filter

Filter Type	Order of Sinc Filter
Sinc1	1
Sinc2	2
Sinc3	3
SincFast	3

7.4.9.7.1 Data Rate and Latency of the Sinc Filter

The data rate of the sinc filter (filter throughput) represented in samples/sec is calculated by the following formula:

$$\text{Data rate of Sinc filter} = \frac{\text{Modulator data rate}}{\text{OSR}} \quad (15)$$

The latency of the sinc filter represented in secs is defined as the amount of time taken by a sinc filter type to deliver the correct filtered output upon initiation. For a given filter type, latency is calculated by the following formula:

$$\text{Latency of Sinc filter} = \frac{\text{Order of Sinc filter}}{\text{Data rate of Sinc filter}} \quad (16)$$

Example configuration:

Sinc filter type	= sinc3
Modulator data rate	= 10 MHz
OSR	= 256
Data rate of Sinc Filter	= 10 MHz / 256 = 39.1 K samples / sec
Sinc filter latency	= 76.8 μ s
Sinc filter type	= sinc2
Modulator data rate	= 10 MHz
OSR	= 256
Data rate of Sinc Filter	= 10 MHz / 256 = 39.1 K samples / sec
Sinc filter latency	= 51.2 μ s

7.4.9.8 Data (Primary) Filter Unit

The data filter is a configurable Sinc filter which supports the following filter types: Sinc1, Sinc2, Sinc3, and SincFast. The data filter OSR (DOSR) settings can be configured from 1 to 256 and is independent of the comparator filter. Effective resolution of the data filter (ENOB) depends upon Data filter type, DOSR, and sigma-delta modulator frequency. By default, the data filter is disabled and setting of SDDFPARMx.FEN = 1 enables the data filter. The data filter output is represented in 26-bit signed integer in two's complement format. This filter unit translates a low input signal as '-1' and a high input signal as '1'. The resulting calculation gives both positive and negative values for the output of the data filter. [Table 7-146](#) shows the different full scale values that the data filter can store using different OSRs.

See [Section 7.4.9.7.1](#) to understand how to calculate data rate and latency of data filter.

Table 7-146. Peak Data Values for Different DOSR/Filter Combinations

DOSR	Sinc1	Sinc2	Sinc3	SincFast
x	x	x ²	x ³	2x ²
4	-4 to 4	-16 to 16	-64 to 64	-32 to 32
8	-8 to 8	-64 to 64	-512 to 512	-128 to 128
16	-16 to 16	-256 to 256	-4096 to 4096	-512 to 512
32	-32 to 32	-1024 to 1024	-32,768 to 32,768	-2048 to 2048
64	-64 to 64	-4096 to 4096	-262,144 to 262,144	-8192 to 8192
128	-128 to 128	-16,384 to 16,384	-2,097,152 to 2,097,152	-32,768 to 32,768
256	-256 to 256	-65,536 to 65,536	-16,777,216 to 16,777,216	-131,072 to 131,072

7.4.9.8.1 32-bit or 16-bit Data Filter Output Representation

The data filter output can be represented in either 32-bit or 16-bit format.

32-bit data filter representation:

- When SDDPARMx.DR = 1, data filter output is represented in 32-bit format. Writes to shift control bits do not have any bearing on the output of the data filter in this configuration.

16-bit data filter representation:

- By default, data filter output is represented in 16-bit format
- When SDDPARMx.DR = 0, data filter output is represented in 16-bit format. But it is the responsibility of the user to configure the corresponding shift control bits in the SDDPARMx register to control which 16-bit part of the 32-bit word is sent to the register map.

For example, for the data filter configuration below:

- Filter type = Sinc3
- OSR = 128
- SDDPARMx.DR = 0

The data filter with a 26-bit signed output value can be in the range of $-16,777,216$ to $16,777,216$. But, 16-bit signed output supports values only from $-32,768$ to $32,767$. Therefore, it is required to configure shift control bits (SDDPARMx.SH) to 7 to represent the data filter output correctly in 16-bit format. [Table 7-147](#) shows the configuration settings of shift control bits for different OSR and filter types.

Table 7-147. Shift Control Bit Configuration Settings

OSR	Sinc1	Sinc2	SincFast	Sinc3
1 to 31	0	0	0	0
32 to 40	0	0	0	1
41 to 50	0	0	0	2
51 to 63	0	0	0	3
64 to 80	0	0	0	4
81 to 101	0	0	0	5
102 to 127	0	0	0	6
128 to 161	0	0	1	7
162 to 181	0	0	1	8
182 to 203	0	1	2	8
204 to 255	0	1	2	9
256	0	2	3	10

CAUTION

Configuring shift control bits incorrectly will result in getting incorrect 16-bit data filter output.

7.4.9.8.2 Data FIFO

Each primary (data) filter channel has a 16-level deep, 32-bit FIFO.

FIFOs can be configured to collect a programmable number of data filter samples before issuing data-ready interrupt. This reduces the number of data-ready interrupts generated and resulting interrupt overhead for managed data flow.

By default, FIFO operation is disabled. FIFOs can be enabled by setting SDFIFOCTLx.FFEN = 1. When FIFO is enabled, each data-ready event from the data filter will populate the FIFO, and the status of the FIFO at any given time is updated in the SDFIFOCTLx.SDFFST bit field.

Setting up FIFO to interrupt after receiving programmable number of data ready events:

- Enable SDFM FIFO (Set SDFIFOCTLx.FFEN = 1)
- Enable SDFM FIFO interrupt (Set SDFIFOCTLx.FFIEN = 1)
- Configure SDFIFOCTLx.SDFFIL bit field to any value between 0 to 16
- Configure SDFM data ready event to interrupt on FIFO interrupt (SDFFINT) (Set SDFFINTx = 1)
- Select data-ready interrupt source is SDFFINTx (DRINTx = SDFFINTx) (SDFIFOCTLx.DRINTSEL = 1)

When the SDFIFOCTLx.SDFFST \geq SDFIFOCTLx.SDFFIL condition is met, the SDIFLG.SDFFINTx bit is set and an interrupt is generated on the DRINTx. SDIFLG.SDFFINTx flag can be cleared by setting the SDIFLGCLR.SDFFINTx bit field.

Wait for Sync feature:

The FIFO wait for sync feature can be used to ignore data-ready events from the data filter until the SDSYNC (from PWM) event is triggered.

By default, the Wait for Sync feature is disabled. This feature can be enabled by setting SDSYNcx.WTSYNcEN = 1

When the wait for sync feature is disabled:

FIFOs get populated on every data ready event until the FIFO gets full (or) when SDFIFOCTLx.SDFFST \geq SDFIFOCTLx.SDFFIL.

When the wait for sync feature enabled:

FIFOs will not be get populated on every data ready event until it receives a SDSYNC event. On a SYSYNC event, it sets SDSYNcx.WTSYNFLG = 1 and data ready events from primary filter will start populating FIFO until either the FIFOs get full (or) when SDFIFOCTLx.SDFFST \geq SDFIFOCTLx.SDFFIL. WTSYNFLG can be cleared either automatically (or) manually.

When WTSYNFLG = 0, FIFOs contents are frozen and subsequent data ready events don't get populate FIFO until next SDSYNC event.

WTSYNFLG automatic clear mode:

By default, this mode is enabled. When SDSYNcx.WTSClREN = 1, WTSYNFLG is automatically cleared on SDFFINT event.

WTSYNFLG manual clear mode:

Setting SDSYNcx.WTSYNCLR = 1 can be used to clear WTSYNFLG manually.

Clearing FIFO contents:

FIFO contents can be cleared by any of the following methods:-

- Disabling FIFO clear FIFO contents. This can be done by clearing SDFIFOCTLx.FFEN = 0.
- Disabling Primary filter clear FIFO contents. This can be done by either clearing SDDFPARMx.FEN = 0 (or) by clearing SDMFILEN.MFE = 0.
- FIFO contents can also be automatically cleared upon receiving the SDSYNC event. By default, this feature is disabled and this feature can be enabled by setting FIFO Clear-on-SDSYNC enable (SDSYNcx.FFSYNcCLREN = 1).

Note: The above feature is only enabled when wait for sync feature is enabled (SDSYNcx.WTSYNcEN = 1).

FIFO debug access behavior:

Debug access of SDDATFIFOx registers does not affect FIFO pointers. On a CPU / CLA / DMA access to SDDATFIFOx register, FIFO read pointers would be advanced to next available entry in FIFO.

7.4.9.8.3 SDSYNC Event

Primary (data) filters can be synchronized with respect to the PWM event (called SDSYNC event). The SDSYNC signal from the PWM module is used to reset the DOSR counter. This feature is by default disabled and can be enabled by setting SDDFPARMx.SDSYNCEN = 1. Each primary filter can be synchronized from any of the available PWMx. SOCA / SOCB signals (see). The SDSYNcx.SDSYNcSEL bits allow the user to configure which PWM signal provides the SDSYNC pulse to the primary filter. [Figure 7-255](#) shows how the PWM signals are connected to SDFM.

Table 7-148. SDSYNcx.SYNcSEL

SYNCSEL[5:0]	SDSYNcx.SYNcSEL[5:0]			
	1	2	3	4
0	PWM0.SOCA	PWM0.SOCA	PWM0.SOCA	PWM0.SOCA
1	PWM0.SOCB	PWM0.SOCB	PWM0.SOCB	PWM0.SOCB
2	PWM1.SOCA	PWM1.SOCA	PWM1.SOCA	PWM1.SOCA
3	PWM1.SOCB	PWM1.SOCB	PWM1.SOCB	PWM1.SOCB
4	PWM2.SOCA	PWM2.SOCA	PWM2.SOCA	PWM2.SOCA
5	PWM2.SOCB	PWM2.SOCB	PWM2.SOCB	PWM2.SOCB
6	PWM3.SOCA	PWM3.SOCA	PWM3.SOCA	PWM3.SOCA
7	PWM3.SOCB	PWM3.SOCB	PWM3.SOCB	PWM3.SOCB
8	PWM4.SOCA	PWM4.SOCA	PWM4.SOCA	PWM4.SOCA
9	PWM4.SOCB	PWM4.SOCB	PWM4.SOCB	PWM4.SOCB
10	PWM5.SOCA	PWM5.SOCA	PWM5.SOCA	PWM5.SOCA
11	PWM5.SOCB	PWM5.SOCB	PWM5.SOCB	PWM5.SOCB
12	PWM6.SOCA	PWM6.SOCA	PWM6.SOCA	PWM6.SOCA
13	PWM6.SOCB	PWM6.SOCB	PWM6.SOCB	PWM6.SOCB
14	PWM7.SOCA	PWM7.SOCA	PWM7.SOCA	PWM7.SOCA
15	PWM7.SOCB	PWM7.SOCB	PWM7.SOCB	PWM7.SOCB
16	PWM8.SOCA	PWM8.SOCA	PWM8.SOCA	PWM8.SOCA
17	PWM8.SOCB	PWM8.SOCB	PWM8.SOCB	PWM8.SOCB
18	PWM9.SOCA	PWM9.SOCA	PWM9.SOCA	PWM9.SOCA
19	PWM9.SOCB	PWM9.SOCB	PWM9.SOCB	PWM9.SOCB
20	PWM10.SOCA	PWM10.SOCA	PWM10.SOCA	PWM10.SOCA
21	PWM10.SOCB	PWM10.SOCB	PWM10.SOCB	PWM10.SOCB
22	PWM11.SOCA	PWM11.SOCA	PWM11.SOCA	PWM11.SOCA
23	PWM11.SOCB	PWM11.SOCB	PWM11.SOCB	PWM11.SOCB
24	PWM12.SOCA	PWM12.SOCA	PWM12.SOCA	PWM12.SOCA
25	PWM12.SOCB	PWM12.SOCB	PWM12.SOCB	PWM12.SOCB
26	PWM13.SOCA	PWM13.SOCA	PWM13.SOCA	PWM13.SOCA
27	PWM13.SOCB	PWM13.SOCB	PWM13.SOCB	PWM13.SOCB
28	PWM14.SOCA	PWM14.SOCA	PWM14.SOCA	PWM14.SOCA
29	PWM14.SOCB	PWM14.SOCB	PWM14.SOCB	PWM14.SOCB
30	PWM15.SOCA	PWM15.SOCA	PWM15.SOCA	PWM15.SOCA
31	PWM15.SOCB	PWM15.SOCB	PWM15.SOCB	PWM15.SOCB
32	PWM16.SOCA	PWM16.SOCA	PWM16.SOCA	PWM16.SOCA
33	PWM16.SOCB	PWM16.SOCB	PWM16.SOCB	PWM16.SOCB
34	PWM17.SOCA	PWM17.SOCA	PWM17.SOCA	PWM17.SOCA
35	PWM17.SOCB	PWM17.SOCB	PWM17.SOCB	PWM17.SOCB
36	PWM18.SOCA	PWM18.SOCA	PWM18.SOCA	PWM18.SOCA

Table 7-148. SDSYNcx.SYNCSEL (continued)

SYNCSEL[5:0]	SDSYNcx.SYNCSEL[5:0]			
	1	2	3	4
37	PWM18.SOCB	PWM18.SOCB	PWM18.SOCB	PWM18.SOCB
38	PWM19.SOCA	PWM19.SOCA	PWM19.SOCA	PWM19.SOCA
39	PWM19.SOCB	PWM19.SOCB	PWM19.SOCB	PWM19.SOCB
40	PWM20.SOCA	PWM20.SOCA	PWM20.SOCA	PWM20.SOCA
41	PWM20.SOCB	PWM20.SOCB	PWM20.SOCB	PWM20.SOCB
42	PWM21.SOCA	PWM21.SOCA	PWM21.SOCA	PWM21.SOCA
43	PWM21.SOCB	PWM21.SOCB	PWM21.SOCB	PWM21.SOCB
44	PWM22.SOCA	PWM22.SOCA	PWM22.SOCA	PWM22.SOCA
45	PWM22.SOCB	PWM22.SOCB	PWM22.SOCB	PWM22.SOCB
46	PWM23.SOCA	PWM23.SOCA	PWM23.SOCA	PWM23.SOCA
47	PWM23.SOCB	PWM23.SOCB	PWM23.SOCB	PWM23.SOCB
48-63	Reserved	Reserved	Reserved	Reserved

ADVANCE INFORMATION

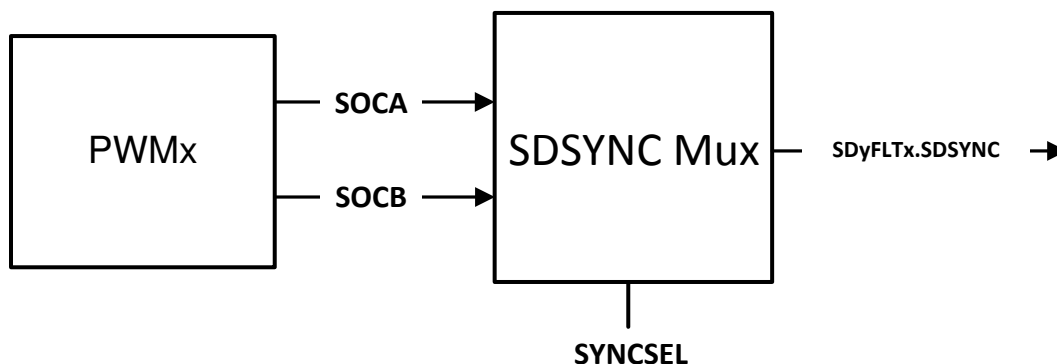

Figure 7-255. SDSYNC Event

Note

Ensure that ONLY ONE SDSYNC event will be generated per PWM timer period. Using PWM in up-count or down-count mode would automatically ensure that you get ONLY SDSYNC event. But, if up-down count mode is used, then make sure that only one SDSYNC event per PWM cycle is generated; otherwise, the filter synchronizer will corrupt SDFM timing by providing two pulses per PWM cycle.

Because of the inherent architecture of the Sinc filter (Sinc1, Sinc2, Sinc3, SincFast), the first few samples, depending upon filter type will be incorrect. [Table 7-149](#) shows the number of incorrect samples on the following conditions:

- When Sinc filter is enabled / configured for first time.
- When Sinc filter is disabled / re-enabled or reconfigured in the middle of operation.
- When data filter receives SDSYNC event from PWM.

Table 7-149. Number of Incorrect Samples Tabulated

Filter Type	Number of Incorrect Samples After the Filter is Enabled and Configured
Sinc1	No incorrect sample
Sinc2	The first sample of the Sinc2 filter is incorrect

Table 7-149. Number of Incorrect Samples Tabulated (continued)

Filter Type	Number of Incorrect Samples After the Filter is Enabled and Configured
SincFast	The first two samples of the SincFast filter are incorrect
Sinc3	The first two samples of the Sinc3 filter are incorrect

CAUTION

SDFM comparator interrupts should be enabled only after providing sufficient settling time to make sure the comparator filter does not trip on these incorrect samples. Therefore, SDFM comparator interrupts (CEVT1 and CEVT2) should be enabled only after a sufficient delay is provided after the comparator filter is configured. This sufficient delay is calculated by adding the latency of the comparator filter and five SD-Cx clock cycles.

7.4.9.9 Comparator (Secondary) Filter Unit

Most control systems require protection of the system by tripping the PWM in case the current or voltage goes out of bounds. The primary purpose of the secondary (comparator) filter is to allow the user to monitor input conditions with a fast settling time. This allows the user to trip PWMs to protect the system from potential damage.

Note

The secondary (comparator) filter cannot be synchronized with respect to the PWM event (SDSYNC event).

The comparator filter is a configurable Sinc filter which supports the following filter types: Sinc1, Sinc2, Sinc3, and SincFast. The comparator OSR (COSR) settings can be configured from 1 to 32 and is independent of the data filter. Effective resolution of the comparator filter (ENOB) depends upon the comparator filter type, COSR, and sigma-delta modulator frequency. By default, the comparator filter is disabled and setting SDCPARMx.CEN = 1 enables the comparator filter. The comparator filter output is represented in 16-bit unsigned format. This filter unit translates a low input signal as '0' and a high input signal as '1'. The resulting calculations give only positive values for the output of the comparator filter. [Table 7-150](#) shows the different full-scale values that the comparator filter can store using different OSRs.

Table 7-150. Peak Data Values for Different OSR/Filter Combinations

OSR	Sinc1	Sinc2	Sinc3	SincFast
x	0 to x	0 to x ²	0 to x ³	0 to 2x ²
4	0 to 4	0 to 16	0 to 64	0 to 32
8	0 to 8	0 to 64	0 to 512	0 to 128
16	0 to 16	0 to 256	0 to 4096	0 to 512
32	0 to 32	0 to 1024	0 to 32,768	0 to 2048

See [Section 7.4.9.7.1](#) to understand how to calculate data rate and latency of comparator filter.

The output of the comparator filter is memory-mapped and can be read in the SDCDATAx register. This register, SDCDATAx, is updated every COSR number of SD-Cx cycles. The comparator filter digital output is connected to digital comparators explained below.

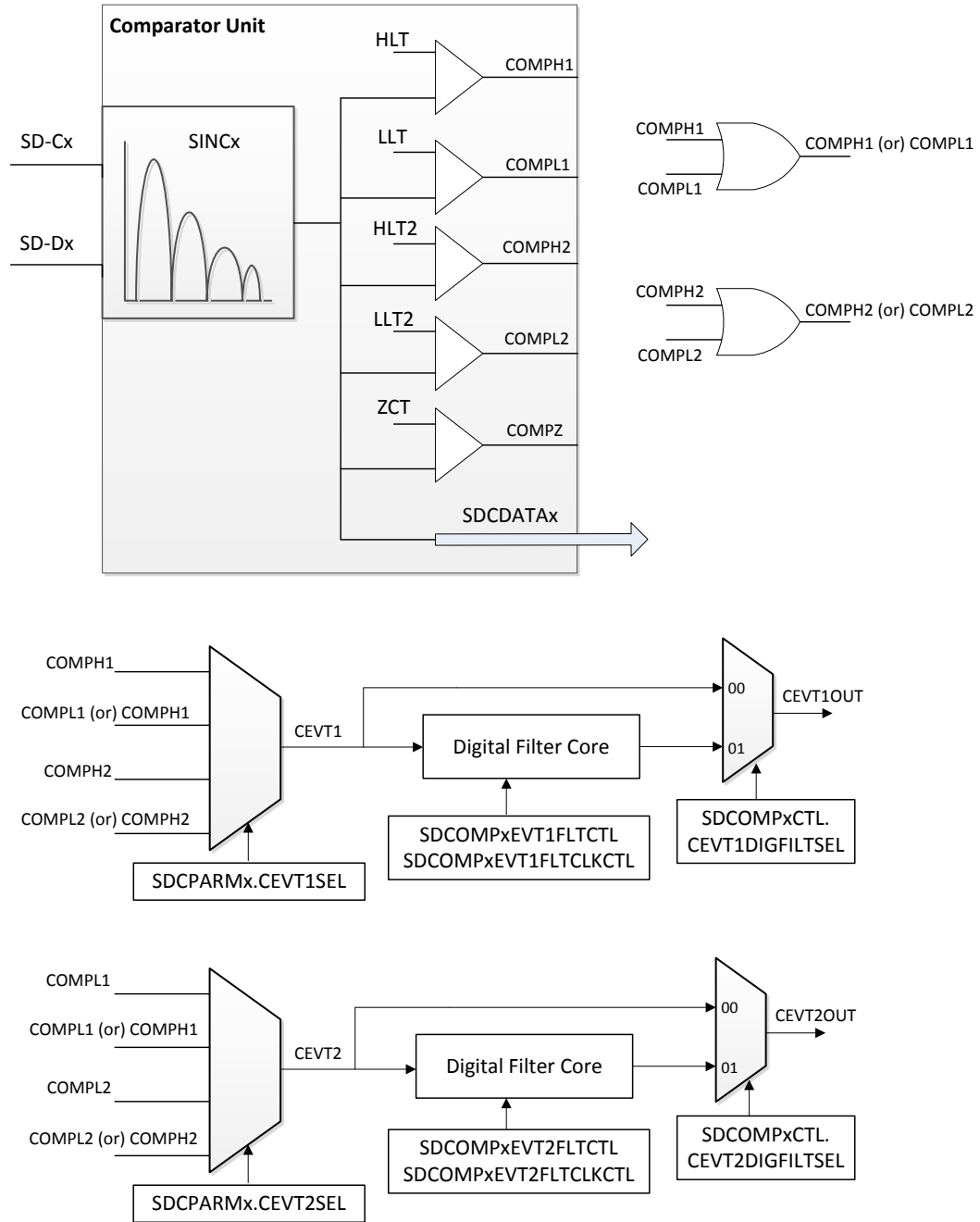

ADVANCE INFORMATION

Figure 7-256. Comparator Unit Structure

7.4.9.9.1 Higher Threshold (HLT) Comparators

- High threshold comparator can be used to detect over-value condition.
- When comparator data \geq higher threshold register, a high threshold event is generated.
- Higher threshold comparator events except for COMPHZx can be configured to trigger following events: CPU interrupt, PWM trip.
- This device has three High Threshold :
 - **Higher Threshold 1 (HLT1) Comparator :**
 - When comparator data \geq (SDFLTxCMPH1.HLT), HLT1 comparator generates COMPH1 event.
 - The COMPH1 event is connected to both CEVT1 and CEVT2.
 - **Higher Threshold 2 (HLT2) Comparator**
 - When comparator data \geq (SDFLTxCMPH2.HLT), HLT2 comparator generates COMPH2 event.
 - The COMPH2 event is connected to both CEVT1 and CEVT2.
 - **Higher Threshold (HTLZ) Comparator**
 - When comparator data \geq (SDFLT1CMPHZ.CMPHZ), it can generate a Higher Threshold (B) event (COMPHZx) and sets the corresponding SDSTATUS.HZx flag. But, this event cannot be configured to generate SDFM interrupt (SDx_ERR). The COMPHZ signals from HTLZ comparator are connected to CLB XBAR.

7.4.9.9.2 Lower Threshold (LLT) Comparators

- The low threshold comparator can be used to detect under-value condition.
- When comparator data \leq Lower Threshold register, a low threshold event is generated.
- Lower threshold comparator events can be configured to trigger following events : CPU interrupt, CLA task, PWM trip.
- Lower threshold comparator events can be used in conjunction with ECAP to measure the frequency / duty cycle of Threshold crossing
- This device has two low threshold comparators. .
 - **Lower Threshold 1 (LLT1) Comparator**
 - When comparator data \leq (SDFLTxCMPL1.LLT), the LLT1 comparator generates COMPL1 event.
 - The COMPL1 event is connected to both CEVT1 and CEVT2.
 - **Lower Threshold 2 (LLT2) Comparator**
 - When comparator data \leq (SDFLTxCMPL2.LLT), LLT2 comparator generates COMPL2 event.
 - The COMPL1 event is connected to both CEVT1 and CEVT2.

7.4.9.9.3 Digital Filter

The digital filter works on a window of FIFO samples ($SAMPWIN + 1$) taken from the input. The filter output resolves to the majority value of the sample window, where majority is defined by the threshold ($THRESH$) value. If the majority threshold is not satisfied, the filter output remains unchanged.

For proper operation, the value of $THRESH$ must be greater than $SAMPWIN / 2$.

A prescale function ($CLKPRESCALE$) determines the filter sampling rate, where the filter FIFO captures one sample every $CLKPRESCALE$ system clocks. Old data from the FIFO is discarded.

A conceptual model of the digital filter is shown in [Figure 7-257](#).

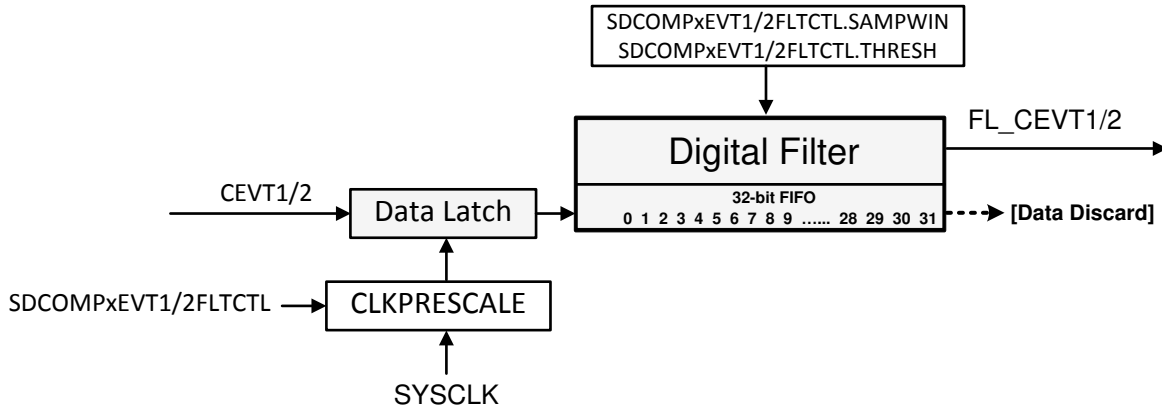

Figure 7-257. Digital Filter

Equivalent C code of the filter implementation is:

```

if (FILTER_OUTPUT == 0) {
    if (Num_1s_in_SAMPWIN >= THRESH) {
        FILTER_OUTPUT = 1;
    }
}
else {
    if (Num_0s_in_SAMPWIN >= THRESH) {
        FILTER_OUTPUT = 0;
    }
}

```

Filter Initialization Sequence

To ensure proper operation of the digital filter, the following initialization sequence is recommended:

1. Configure the digital filter parameters for operation:
 - Set $SAMPWIN$ for the number of samples to monitor in the FIFO window.
 - Set $THRESH$ for the threshold required for majority qualification.
 - Set $CLKPRESCALE$ for the digital filter clock prescale value.
2. Initialize the sample values in the digital FIFO window by setting $FILINIT = 1$.

7.4.9.10 Theoretical SDFM Filter Output

The following equations can be used to derive a theoretical filter output of an SDFM filter output for both a comparator filter and a data filter.

$$\text{Density of ones in bitstream} = \frac{\text{Input Voltage} + V_{\text{clipping}}}{2 \times V_{\text{clipping}}} \quad (17)$$

Where:

- V_{clipping} = maximum differential voltage input range of modulator
- Input voltage = Differential input voltage applied to the modulator

$$\begin{aligned} \text{Comparator Filter Output (Theoretical)} = \\ \text{Density of ones in bitstream} \times \text{Maximum Filter Output (FilterType, COSR)} \end{aligned} \quad (18)$$

$$\text{FilterOutput} = \left\{ \frac{\text{absolute}(\text{Input voltage})}{V_{\text{clipping}}} \right\} \times \text{Maximum Filter Output (FilterType, DOSR)} \quad (19)$$

$$\text{Data Filter Output}_{32\text{bit}}(\text{Theoretical}) = \begin{cases} \text{FilterOutput} & \text{if Input Voltage is +ve voltage} \\ 2\text{'s complement} & \text{if input voltage is -ve voltage} \\ \text{of FilterOutput} & \end{cases} \quad (20)$$

$$\begin{aligned} \text{Data Filter Output}_{16\text{bit}}(\text{Theoretical}) = \\ \text{Data Filter Output}_{32\text{bit}}(\text{Theoretical}) \gg \text{Shift value}(\text{FilterType, OSR}) \end{aligned} \quad (21)$$

For example, when using the AMC1306x25 modulator:

AMC1306x25	Vclipping = Input voltage (AINP - AINN) =	320 mV 100 mV
SDFM filter settings	Filter type = Comparator OSR (COSR) = Data filter OSR (DOSR) =	3 32 100

Density of ones in bitstream	Using Equation 17	0.65625
Comparator filter output Filter type = Sinc3 COSR = 32	Using Equation 18	21504
Data filter output (32-bit) Filter type = Sinc3 DOSR = 100	Using Equation 19 and Equation 20	312500
Data filter output (32-bit) Filter type = Sinc3 DOSR = 100 (Right shift by 5)	Using Equation 21	9765

7.4.9.11 Interrupt Unit

Each SDFM can generate five CPU interrupts such as SDFM Error (SDy_ERR) and SDFM data ready (SDy_DRINT1 / SDy_DRINT2, SDy_DRINT3, SDy_DRINT4) interrupts for each filter module.

7.4.9.11.1 SDFM (SDyERR) Interrupt Sources

Figure 7-258 shows the structure of SDy_ERR interrupt. SDy_ERR interrupt can be triggered by any of these 16 events.

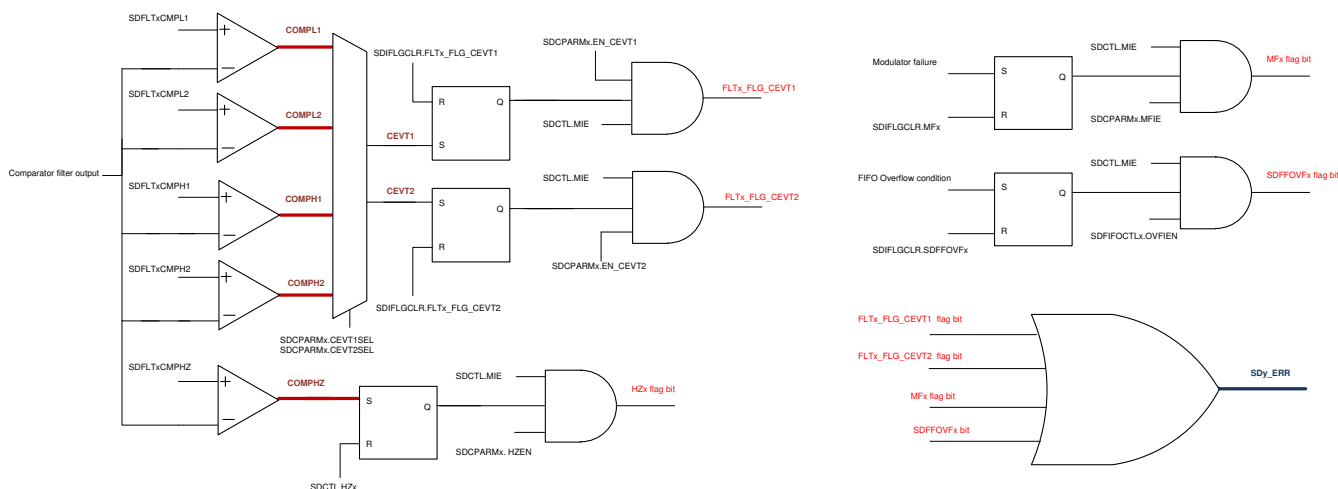

Figure 7-258. SDFM Error (SD_ERR) Interrupt Sources

1. Comparator Event1 (CEVT1)

events from any of the four comparator filter module can trigger CPU interrupt. This event can be configured to trigger SDy_ERR interrupt only if below configurations are made:

- Enable Main interrupt enable (SDCTL.MIE = 1)
- Enable comparator Event1 interrupt (SDCPARMx.EN_CEVT1 = 1)

On a CEVT1 event, SDIFLG.FLTx_FLG_CEVT1 flag bit is set. This flag bit can only be reset if the corresponding bit in SDIFLGCLR register is set and if the interrupt source is no longer active.

2. Comparator Event2 (CEVT2)

CEVT2 events from any of the four comparator filter module can trigger CPU interrupt. This event can be configured to trigger SDy_ERR interrupt only if below configurations are made:

- Enable Main interrupt enable (SDCTL.MIE = 1)
- Enable comparator event1 interrupt (SDCPARMx.EN_CEVT2 = 1)

On a CEVT2 event, SDIFLG.FLTx_FLG_CEVT2 flag bit is set. This flag bit can only be reset if the corresponding bit in SDIFLGCLR register is set and if the interrupt source is no longer active.

3. Modulator Failure (MFx) event

Modulator failures (MFx) are generated when SD-Cx goes missing. The modulator clock is considered missing if SD-Cx does not toggle for 64-SYSCLKs. MFx events from any of the four filter modules can trigger CPU interrupt. This event can be configured to trigger SDy_ERR interrupt only if below configurations are made:

- Enable Main Interrupt Enable (SDCTL.MIE = 1)
- Enable modulator clock failure interrupt source (SDCPARMx.MFIE = 1)

On a MFx event, SDIFLG.MFx flag bit is set. This flag bit can only be reset if the corresponding bit in SDIFLGCLR register is set and if the interrupt source is no longer active.

4. FIFO overflow (SDFFOVx) event

The number of filter data available in FIFO at any given point can be tracked in SDFIFOCTLx.SDFFST. If the number of words received in FIFO is greater than Max FIFO depth (16), SDFFOVx event is generated. SDFFOVx events from any of the four filter modules can trigger CPU interrupt. This event can be configured to trigger SDy_ERR interrupt, only if below configurations are made:

- Enable SDFM FIFO (Set SDFIFOCTLx.FFEN = 1)
- Enable SDFM FIFO overflow interrupt (Set SDFIFOCTLx.OVFIEN = 1) and
- Enable Main interrupt enable (Set SDCTL.MIE = 1)

On a SDFFOVx event, all subsequent data (primary) filter data is lost and is not stored in FIFO. SDIFLG.SDFFOVx flag bit is set on a FIFO overflow event and this bit can be cleared if the corresponding bit in SDIFLGCLR register is set and if the interrupt source is no longer active.

7.4.9.11.2 Data Ready (DRINT) Interrupt Sources

Figure 7-259 shows the structure of interrupt SDy_DRINTx interrupt. Each SDy_DRINTx interrupt is triggered by corresponding Data Filter channel.

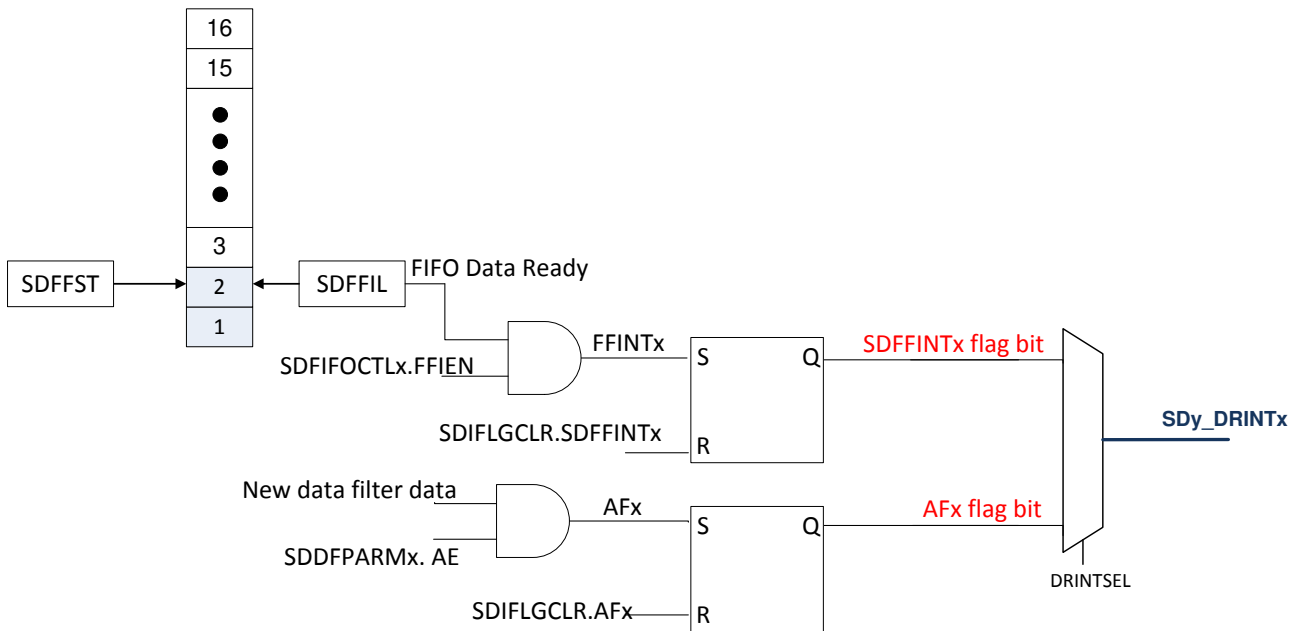

Figure 7-259. SDFM Data Ready (SDy_DRINTx) Interrupt

1. Data Acknowledge (AFx)

When the primary filter is ready with a new filter data, AFx event is generated. AFx events from each filter can generate its own SDy_DRINTx interrupt. This event can be configured to trigger SDy_DRINTx interrupt only if below configurations are made:

- Enable individual filter interrupts (SDDFPARMx.AE = 1)
- Select data-ready interrupt source AFx (DRINTx = AFx) (SDFIFOCTLx.DRINTSEL = 0)

On an AFx event, the SDIFLG.AFx flag bit is set. This flag bit can only be reset if the corresponding bit in SDIFLGCLR register is set and if the interrupt source is no longer active.

2. Four FIFO Data ready interrupt (SDFINTx)

FIFO Data Ready event is generated whenever SDFIFOCTLx.SDFFST >= SDFIFOCTLx.SDFFIL condition is met. FIFO data ready events from each filter can generate its own SDy_DRINTx interrupt. This event can be configured to trigger SDy_DRINTx interrupt only if below configurations are made:

Table 7-151 shows how the DRINTx output is selected.

- Enable SDFM FIFO (Set SDFIFOCTLx.FFEN = 1) and
- Enable SDFM FIFO interrupt (Set SDFIFOCTLx.FFIEN = 1)
- Select data-Ready interrupt source is SDFINTx (DRINTx = SDFINTx) (SDFIFOCTLx.DRINTSEL = 1)

Table 7-151. SDFM Data-Ready Interrupt (SDy_DRINTx) Output Selection

DRINTSEL	AE	FFIEN	FFEN	DRINTx
0	0	x	X	0
0	1	x	X	AFx
1	x	0	X	0
1	x	x	0	0
1	x	1	1	SDFINTx

7.4.10 Crossbar (XBAR)

The crossbars (referred to as XBAR throughout this chapter) provide flexibility to connect device inputs, outputs, and internal resources in a variety of configurations.

The real time control subsystem contains a total of six XBARs:

- INPUT XBAR
- PWM XBAR
- INT XBAR
- DMA XBAR
- OUTPUT XBAR
- PWM SyncOut XBAR

Each of the XBARs is named according to signal destination it routes its inputs. For example, the INPUT XBAR brings external signals "in" to the device. The OUTPUT XBAR takes internal signals "out" of the device to a GPIO. The PWM XBAR takes the signal to the trip inputs of the PWM. The INT XBAR routes the huge list of real time CONTROLSS interrupts efficiently to the SoC interrupt controller. The DMA XBARs route DMA requests from the real-time CONTROLSS to the SOC EDMA module. Both the INT XBAR and DMA XBAR limit the number of interrupt and dma requests from CONTROLSS to SOC. The programming model also needs to be done in 2 steps. The PWM SyncOut XBAR routes all the PWM synchronous sync outputs to SoC time sync logic and to the OUTPUT XBAR.

Further details about each of these XBARs can be found in the following sections.

7.4.10.1 INPUTXBAR	700
7.4.10.2 PWMXBAR	701
7.4.10.3 INTXBAR	703
7.4.10.4 DMAXBAR	704
7.4.10.5 OUTPUTXBAR	704
7.4.10.6 PWMSYNCOUXTBAR	723

7.4.10.1 INPUTXBAR

On this device, the input x-bar is used to route signals from any GPIO to different IP blocks such as the eCAP(s), ePWM(s), ICSS GPI(s), and the PWMXBAR. The INPUTXBAR has access to every GPIO and can route each signal to any (or multiple) of the IP blocks previously mentioned. This flexibility relieves some of the constraints on peripheral muxing by enabling any available GPIO pin to be used for slow changing I/O signals to control subsystem. It is important to note that the function selected on the GPIO mux does not affect the INPUTXBAR. The INPUTXBAR simply connects the signal on the input buffer to the selected destination. This flexibility enables routing the output of one peripheral to another (for example, measure the output of an ePWM with an eCAP for a frequency test). Apart from GPIOs, ICSS GPO(s), can also be used as inputs to the INPUTXBAR and be used in a similar fashion to any GPIO source.

The architecture of the INPUTXBAR is composed of multiple input unit x-bars which routes any of the INPUTXBAR sources to the single output of the cross bar. The two step mux logic ensures that only one source is routed to the output.

The INPUTXBAR is configured by way of input select registers [INPUTXBAR[31:0]_G[1:0].SEL and INPUTXBAR[31:0].GSEL]. The available IP sources and IP destinations are shown below. For more information on configuration, see the INPUT_XBAR_REGS register definitions in the XBAR register section.

Note

Please note INPUTXBAR routes GPIO pin to any of its 32 outputs and is not a OR implementation like most of CONTROLSSS XBARs

ADVANCE INFORMATION

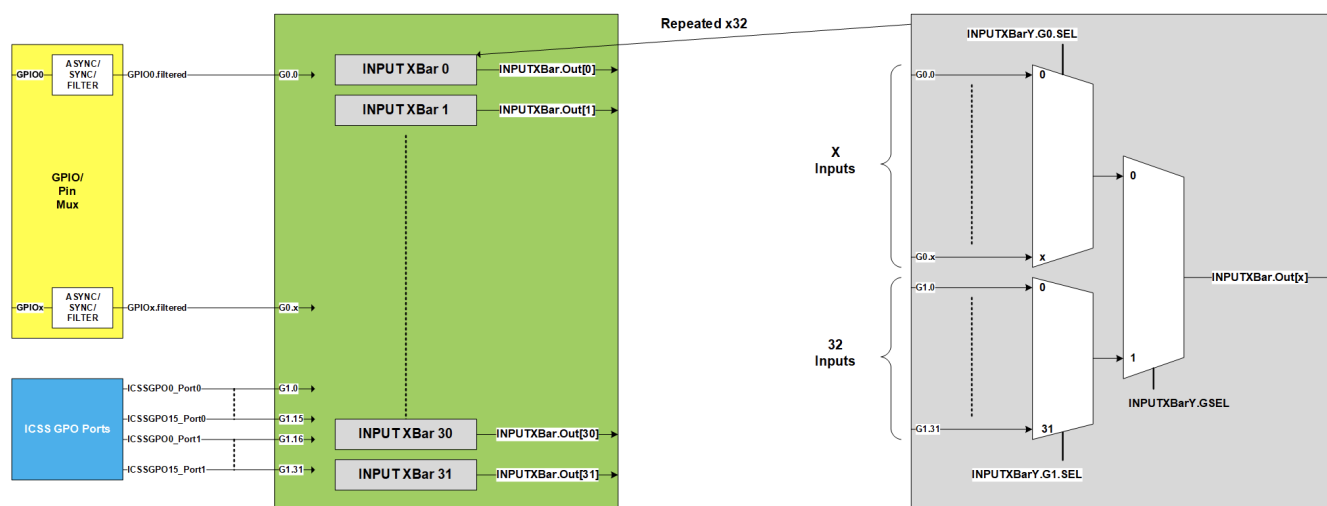

Figure 7-260. INPUTXBAR Functional Block Diagram

Note

Parameters for table below

w=5

x=[15:0]

y=[31:16]

z=[31:0]

u=[9:0]

INPUTXBAR Outputs	Destination-1	Destination-2	Destination-3
INPUTXBAR.Out0	PWMXBAR.G4.0	EPWMx.TZ1	ECAPu.ECAPIN.202
INPUTXBAR.Out1	PWMXBAR.G4.1	EPWMx.TZ2	ECAPu.ECAPIN.203
INPUTXBAR.Out2	PWMXBAR.G4.2	EPWMx.TZ3	ECAPu.ECAPIN.204
INPUTXBAR.Out3	PWMXBAR.G4.3	EPWMx.TZ4	ECAPu.ECAPIN.205

INPUTXBAR Outputs	Destination-1	Destination-2	Destination-3
INPUTXBAR.Out4	PWMXBAR.G4.4	EPWMz.SYNCIN.80	ECAPu.ECAPIN.206
INPUTXBAR.Out5	PWMXBAR.G4.5	ADCw.TRIG.5	ECAPu.ECAPIN.207
INPUTXBAR.Out6	PWMXBAR.G4.6		ECAPu.ECAPIN.208
INPUTXBAR.Out7	PWMXBAR.G4.7		ECAPu.ECAPIN.209
INPUTXBAR.Out8	PWMXBAR.G4.8		ECAPu.ECAPIN.210
INPUTXBAR.Out9	PWMXBAR.G4.9		ECAPu.ECAPIN.211
INPUTXBAR.Out10	PWMXBAR.G4.10		ECAPu.ECAPIN.212
INPUTXBAR.Out11	PWMXBAR.G4.11		ECAPu.ECAPIN.213
INPUTXBAR.Out12	PWMXBAR.G4.12		ECAPu.ECAPIN.214
INPUTXBAR.Out13	PWMXBAR.G4.13		ECAPu.ECAPIN.215
INPUTXBAR.Out14	PWMXBAR.G4.14		ECAPu.ECAPIN.216
INPUTXBAR.Out15	PWMXBAR.G4.15		ECAPu.ECAPIN.217
INPUTXBAR.Out16	PWMXBAR.G4.16	EPWMy.TZ1	ECAPu.ECAPIN.218
INPUTXBAR.Out17	PWMXBAR.G4.17	EPWMy.TZ2	ECAPu.ECAPIN.219
INPUTXBAR.Out18	PWMXBAR.G4.18	EPWMy.TZ3	ECAPu.ECAPIN.220
INPUTXBAR.Out19	PWMXBAR.G4.19	EPWMy.TZ4	ECAPu.ECAPIN.221
INPUTXBAR.Out20	PWMXBAR.G4.20	EPWMz.SYNCIN.81	ECAPu.ECAPIN.222
INPUTXBAR.Out21	PWMXBAR.G4.21		ECAPu.ECAPIN.223
INPUTXBAR.Out22	PWMXBAR.G4.22		ECAPu.ECAPIN.224
INPUTXBAR.Out23	PWMXBAR.G4.23		ECAPu.ECAPIN.225
INPUTXBAR.Out24	PWMXBAR.G4.24		ECAPu.ECAPIN.226
INPUTXBAR.Out25	PWMXBAR.G4.25		ECAPu.ECAPIN.227
INPUTXBAR.Out26	PWMXBAR.G4.26		ECAPu.ECAPIN.228
INPUTXBAR.Out27	PWMXBAR.G4.27		ECAPu.ECAPIN.229
INPUTXBAR.Out28	PWMXBAR.G4.28		ECAPu.ECAPIN.230
INPUTXBAR.Out29	PWMXBAR.G4.29		ECAPu.ECAPIN.231
INPUTXBAR.Out30	PWMXBAR.G4.30		ECAPu.ECAPIN.232
INPUTXBAR.Out31	PWMXBAR.G4.31		ECAPu.ECAPIN.233

For more information on configuration, see the INPUTXBAR register definitions.

7.4.10.2 PWMXBAR

On this device, the PWM x-bar is used to route signals to trip inputs of different ePWM instances. Valid sources of trip inputs to ePWM could be Compare subsystem trip high and low events, SDFM filter events, ADC events, input x-bar outputs, ePWM tripout events, eQEP error events, FSIRX triggers, and eCAP trip outputs. The architecture allows any of the inputs to ePWM crossbar to be routed to any ePWM trip input.

The architecture of the PWMXBAR is composed of pwm unit x-bars which routes any of the pwm triggers to the single output of the cross bar. If needed, the same trip source can be routed to multiple PWM x-bar outputs by suitable programming. Each unit x-bar also has an associated set of status and clear/flags which can be used by application to know about an event. The clear flags allows to clear the captured events in a controlled fashion.

The PWM cross bar outputs are grouped in two as shown in the PWM x-bar destination table below. PWM x-bar outputs can also trigger ICSSM GPI inputs and can capture any inputs to the PWM trip inputs.

The PWM x-bar inputs can be routed to PWM x-bar output by writing to configuration registers [PWMXBAR[31:0]_G[8:0].SEL]. The available IP sources for input x-bar is shown in figure below and the destinations in table below. For more information on configuration, see the PWM_XBAR_REGS register definitions in the XBAR register section. The PWM x-bar internal structure is shown in figure below.

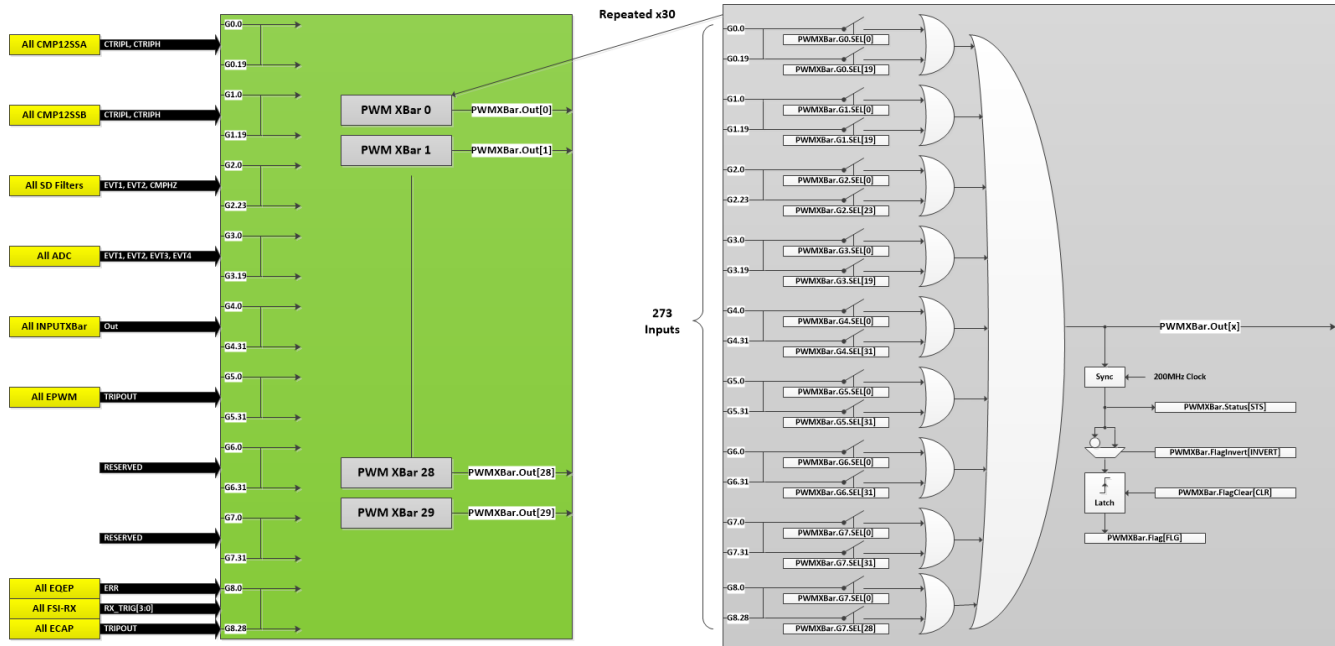

Figure 7-261. PWMXBAR

Note

Parameters for table below
 $x=[15:0], y=[31:16]$

PWMXBAR Outputs	Destination-1	Destination-2	Destination-3
PWMXBAR.Out0	EPWMx.TripInput.1	ICSSM.GPI_Port0.0	ICSSM.GPI_Port1.0
PWMXBAR.Out1	EPWMx.TripInput.2	ICSSM.GPI_Port0.1	ICSSM.GPI_Port1.1
PWMXBAR.Out2	EPWMx.TripInput.3	ICSSM.GPI_Port0.2	ICSSM.GPI_Port1.2
PWMXBAR.Out3	EPWMx.TripInput.4	ICSSM.GPI_Port0.3	ICSSM.GPI_Port1.3
PWMXBAR.Out4	EPWMx.TripInput.5	ICSSM.GPI_Port0.4	ICSSM.GPI_Port1.4
PWMXBAR.Out5	EPWMx.TripInput.6	ICSSM.GPI_Port0.5	ICSSM.GPI_Port1.5
PWMXBAR.Out6	EPWMx.TripInput.7	ICSSM.GPI_Port0.6	ICSSM.GPI_Port1.6
PWMXBAR.Out7	EPWMx.TripInput.8	ICSSM.GPI_Port0.7	ICSSM.GPI_Port1.7
PWMXBAR.Out8	EPWMx.TripInput.9	ICSSM.GPI_Port0.8	ICSSM.GPI_Port1.8
PWMXBAR.Out9	EPWMx.TripInput.10	ICSSM.GPI_Port0.9	ICSSM.GPI_Port1.9
PWMXBAR.Out10	EPWMx.TripInput.11	ICSSM.GPI_Port0.10	ICSSM.GPI_Port1.10
PWMXBAR.Out11	EPWMx.TripInput.12	ICSSM.GPI_Port0.11	ICSSM.GPI_Port1.11
PWMXBAR.Out12	EPWMx.TripInput.13	ICSSM.GPI_Port0.12	ICSSM.GPI_Port1.12
PWMXBAR.Out13	EPWMx.TripInput.14	ICSSM.GPI_Port0.13	ICSSM.GPI_Port1.13
PWMXBAR.Out14	EPWMx.TripInput.15	ICSSM.GPI_Port0.14	ICSSM.GPI_Port1.14
PWMXBAR.Out15	EPWMy.TripInput.1	ICSSM.GPI_Port0.15	ICSSM.GPI_Port1.15
PWMXBAR.Out16	EPWMy.TripInput.2	ICSSM.GPI_Port0.16	ICSSM.GPI_Port1.16
PWMXBAR.Out17	EPWMy.TripInput.3	ICSSM.GPI_Port0.17	ICSSM.GPI_Port1.17
PWMXBAR.Out18	EPWMy.TripInput.4	ICSSM.GPI_Port0.18	ICSSM.GPI_Port1.18

PWMXBAR Outputs	Destination-1	Destination-2	Destination-3
PWMXBAR.Out19	EPWMy.TriplInput.5	ICSSM.GPI_Port0.19	ICSSM.GPI_Port1.19
PWMXBAR.Out20	EPWMy.TriplInput.6	ICSSM.GPI_Port0.20	ICSSM.GPI_Port1.20
PWMXBAR.Out21	EPWMy.TriplInput.7	ICSSM.GPI_Port0.21	ICSSM.GPI_Port1.21
PWMXBAR.Out22	EPWMy.TriplInput.8	ICSSM.GPI_Port0.22	ICSSM.GPI_Port1.22
PWMXBAR.Out23	EPWMy.TriplInput.9	ICSSM.GPI_Port0.23	ICSSM.GPI_Port1.23
PWMXBAR.Out24	EPWMy.TriplInput.10	ICSSM.GPI_Port0.24	ICSSM.GPI_Port1.24
PWMXBAR.Out25	EPWMy.TriplInput.11	ICSSM.GPI_Port0.25	ICSSM.GPI_Port1.25
PWMXBAR.Out26	EPWMy.TriplInput.12	ICSSM.GPI_Port0.26	ICSSM.GPI_Port1.26
PWMXBAR.Out27	EPWMy.TriplInput.13	ICSSM.GPI_Port0.27	ICSSM.GPI_Port1.27
PWMXBAR.Out28	EPWMy.TriplInput.14	ICSSM.GPI_Port0.28	ICSSM.GPI_Port1.28
PWMXBAR.Out29	EPWMy.TriplInput.15	ICSSM.GPI_Port0.29	ICSSM.GPI_Port1.29

7.4.10.3 INTXBAR

On this device, the INT x-bar is used to route real-time CONTROLSS peripheral interrupts to the SoC interrupt controller. The idea is to limit the number of interrupts to 32 within real-time CONTROLSS before connecting to the SOC interrupt controller.

The INT x-bar is further made up of unit x-bars, its architecture allows multiple interrupt sources to be active. For ease of readability, the interrupt sources are grouped together based on IP generating the same. Interrupt sources are active low and before entering the x-bar, these are inverted to be active high.

The INT x-bar configured by way of the INTXBAR[31:0].G[6:0].SEL registers. The available IP source for each INPUTx is shown in INTXBAR figure below.

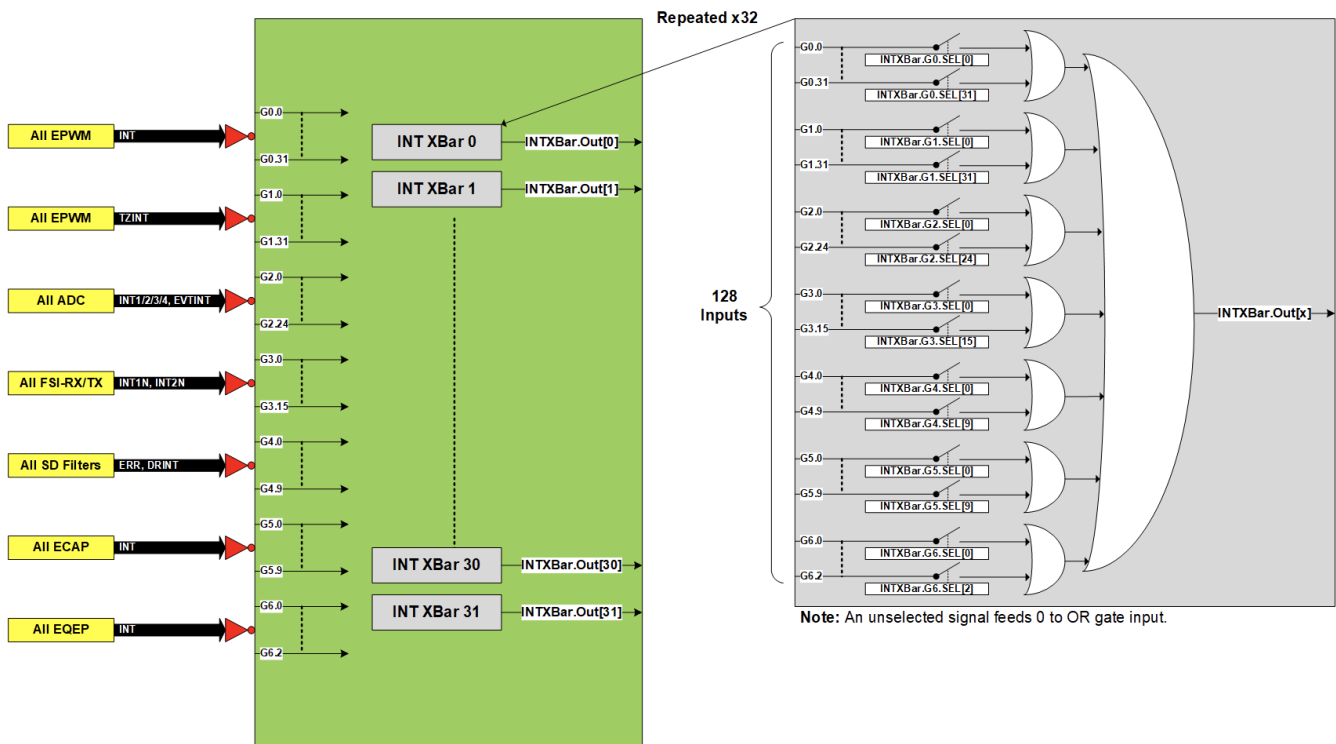

7.4.10.4 DMAXBAR

On this device, the DMA x-bar is used to route DMA requests from real-time control subsystem peripherals to the SoC EDMA. The idea is to limit the number of DMA requests to 16 within real-time control subsystem before connecting it to the SOC EDMA.

The DMA x-bar is further made up of unit x-bars, which allows 2 tier selection of any one of the DMA request sources. Except for the ePWM(s) SOCA and SOCB, rest of the DMA sources are active low and before entering the x-bar, these are inverted to be active high.

The DMA x-bar configured by way of the DMAXBar[31:0].G[5:0].SEL and DMAXBAR[5:0].GSEL registers. The available IP sources for each INPUTx is shown in DMA x-bar figure below

Note

Please note DMAXBAR routes DMA requests from CONTROLSS IPs to any of its 16 outputs and is not a OR implementation like most of CONTROLSS XBARs

ADVANCE INFORMATION

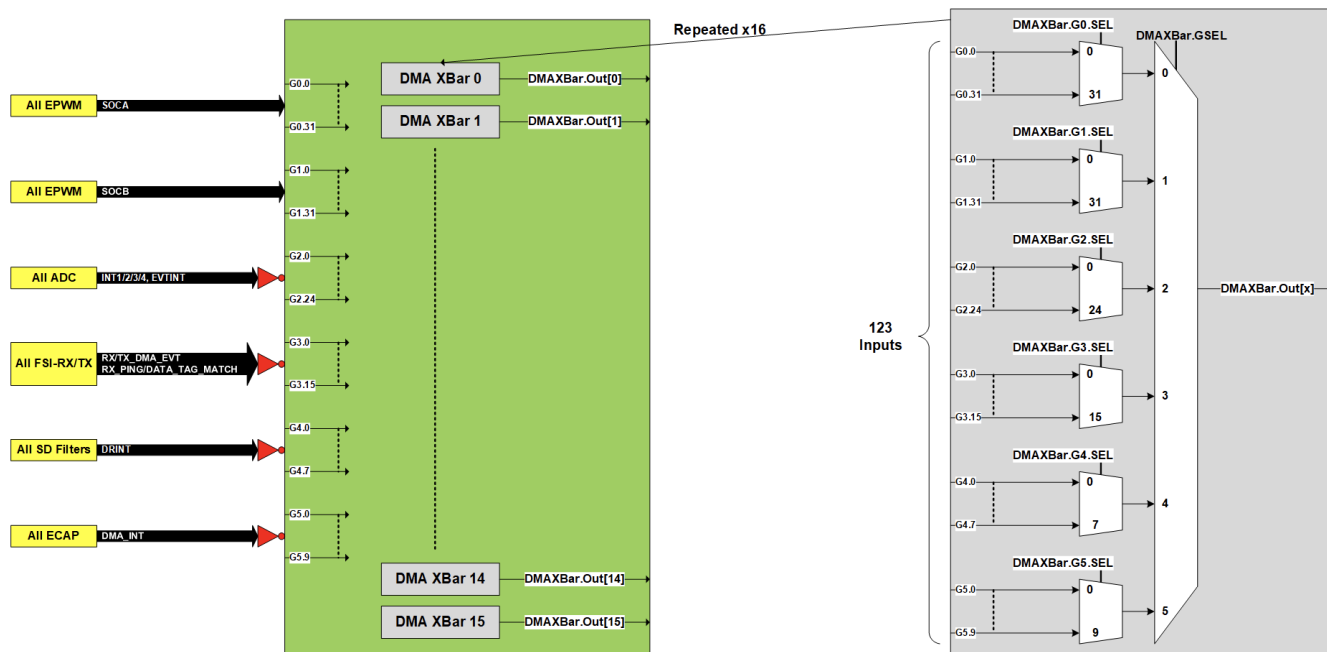

Figure 7-262. DMAXBAR Block Diagram

7.4.10.5 OUTPUTXBAR

On this device, the OUTPUT x-bar is used to route signals from all the control peripheral trip events to the output x-bar mapped pads or to the ICSSM interrupts.

The source of these trip events is EPWM trip outputs, SOCA, SOCB, Diode Emulation logic generated active and trip events, SD filter events, compare subsystem high and low trips, ADC events, PWM syncout x-bar sync outputs, EQEP index and strobe, and ECAP outputs.

The architecture of the output x-bar is composed of output unit x-bars which routes any of the output x-bar inputs to the single output of the unit x-bar. If needed, the same trip source can be routed to multiple OUTPUT x-bar outputs by suitable programming. Each output unit x-bar also has an associated set of status and clear/flags which can be used by application to know about an event by reading the status bit. The clear flags allows to clear the captured events in a controlled fashion. Since the output x-bar is routed to GPIOs, the design allows the internal low width pulses to be stretched to 16 or 32 cycles of 200MHz real-time control subsystem clock. The design allows to control the polarity of the signal latched by the status registers.

The OUTPUTXBAR configured by way of the OUTPUTxSELECT registers. The available IP sources for each INPUTx is shown in OUTPUTXBAR figure below. While the Output x-bar outputs destination is show in the table below.

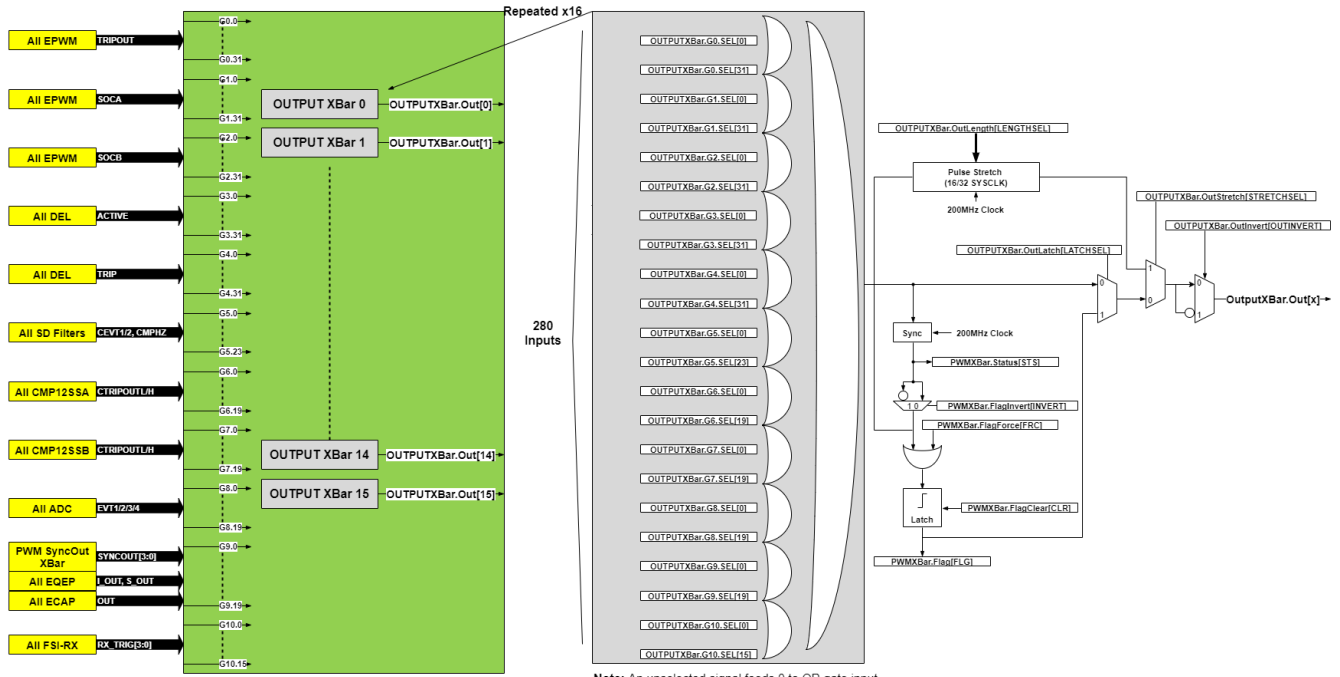

Note: An unselected signal feeds 0 to OR gate input.

Parameters for table below
x=[3:0]

OUTPUTXBAR Outputs	Destination-1	Destination-2	Destination-3	Destination-3	Destination-4
OUTPUTXBAR.Out0	ICSSM_SYNC0_P AD	FSI_TXx.EXTTRI GGER63	FSI_TXx.EXTPIN GTRIGGER63	FSI_TXx.EXTPIN GTRIGGER63	ICCM.PR1_SLAV E_INTR.31
OUTPUTXBAR.Out1	ICSSM_LATCH0_ PAD	FSI_TXx.EXTTRI GGER62	FSI_TXx.EXTPIN GTRIGGER62	FSI_TXx.EXTPIN GTRIGGER62	ICCM.PR1_SLAV E_INTR.32
OUTPUTXBAR.Out2	MMCS_D_WP_PA D	FSI_TXx.EXTTRI GGER61	FSI_TXx.EXTPIN GTRIGGER61	FSI_TXx.EXTPIN GTRIGGER61	ICCM.PR1_SLAV E_INTR.33
OUTPUTXBAR.Out3	MMCS_D_CD_PA D	FSI_TXx.EXTTRI GGER60	FSI_TXx.EXTPIN GTRIGGER60	FSI_TXx.EXTPIN GTRIGGER60	ICCM.PR1_SLAV E_INTR.34
OUTPUTXBAR.Out4	MMCS_D_POW_P AD	FSI_TXx.EXTTRI GGER59	FSI_TXx.EXTPIN GTRIGGER59	FSI_TXx.EXTPIN GTRIGGER59	ICCM.PR1_SLAV E_INTR.35
OUTPUTXBAR.Out5	I2C0_SCL_PA D	FSI_TXx.EXTTRI GGER58	FSI_TXx.EXTPIN GTRIGGER58	FSI_TXx.EXTPIN GTRIGGER58	ICCM.PR1_SLAV E_INTR.36
OUTPUTXBAR.Out6	I2C0_SDA_PA D	FSI_TXx.EXTTRI GGER57	FSI_TXx.EXTPIN GTRIGGER57	FSI_TXx.EXTPIN GTRIGGER57	ICCM.PR1_SLAV E_INTR.37
OUTPUTXBAR.Out7	UART0_RTS_PA D	FSI_TXx.EXTTRI GGER56	FSI_TXx.EXTPIN GTRIGGER56	FSI_TXx.EXTPIN GTRIGGER56	ICCM.PR1_SLAV E_INTR.38
OUTPUTXBAR.Out8	UART0_CTS_PA D	FSI_TXx.EXTTRI GGER55	FSI_TXx.EXTPIN GTRIGGER55	FSI_TXx.EXTPIN GTRIGGER55	ICCM.PR1_SLAV E_INTR.39
OUTPUTXBAR.Out9	SPI1_CS_PA D	FSI_TXx.EXTTRI GGER54	FSI_TXx.EXTPIN GTRIGGER54	FSI_TXx.EXTPIN GTRIGGER54	ICCM.PR1_SLAV E_INTR.40
OUTPUTXBAR.Out10	SPI1_CLK_PA D	FSI_TXx.EXTTRI GGER53	FSI_TXx.EXTPIN GTRIGGER53	FSI_TXx.EXTPIN GTRIGGER53	ICCM.PR1_SLAV E_INTR.41
OUTPUTXBAR.Out11	SPI1_TX_PA D	FSI_TXx.EXTTRI GGER52	FSI_TXx.EXTPIN GTRIGGER52	FSI_TXx.EXTPIN GTRIGGER52	ICCM.PR1_SLAV E_INTR.42
OUTPUTXBAR.Out12	SPI1_RX_PA D	FSI_TXx.EXTTRI GGER51	FSI_TXx.EXTPIN GTRIGGER51	FSI_TXx.EXTPIN GTRIGGER51	ICCM.PR1_SLAV E_INTR.43

OUTPUTXBAR Outputs	Destination-1	Destination-2	Destination-3	Destination-3	Destination-4
OUTPUTXBAR.Out13	SPI2_CS_PAD	FSI_TXx.EXTTRIGGER50	FSI_TXx.EXTPIN GTRIGGER50	FSI_TXx.EXTPIN GTRIGGER50	ICCM.PR1_SLAV E_INTR.44
OUTPUTXBAR.Out14	SPI2_CLK_PAD	FSI_TXx.EXTTRIGGER49	FSI_TXx.EXTPIN GTRIGGER49	FSI_TXx.EXTPIN GTRIGGER49	ICCM.PR1_SLAV E_INTR.45
OUTPUTXBAR.Out15	ICSSM_MII1_TXD 3_PAD	FSI_TXx.EXTTRIGGER48	FSI_TXx.EXTPIN GTRIGGER48	FSI_TXx.EXTPIN GTRIGGER48	ICCM.PR1_SLAV E_INTR.46

7.4.10.5.1 OUTPUTXBAR Input Connection Table

Group-Input	Source Module-Signal	Group-Input	Source Module-Signal	Group-Input	Source Module-Signal	Group-Input	Source Module-Signal		
G0-0	EPWM0-TRIPOUT	G1-0	EPWM0-SOCA	G2-0	EPWM0-SOCB	G3-0	Unused	G4-0	Unused
G0-1	EPWM1-TRIPOUT	G1-1	EPWM1-SOCA	G2-1	EPWM1-SOCB	G3-1	Unused	G4-1	Unused

ADVANCE INFORMATION

Group-Input	Source Module-Signal	Group-Input	Source Module-Signal	Group-Input	Source Module-Signal	Group-Input	Source Module-Signal		
G0-2	EPWM2-TRIPOUT	G1-2	EPWM2-SOCA	G2-2	EPWM2-SOCB	G3-2	Unused	G4-2	Unused
G0-3	EPWM3-TRIPOUT	G1-3	EPWM3-SOCA	G2-3	EPWM3-SOCB	G3-3	Unused	G4-3	Unused
G0-4	EPWM4-TRIPOUT	G1-4	EPWM4-SOCA	G2-4	EPWM4-SOCB	G3-4	Unused	G4-4	Unused

ADVANCE INFORMATION

ADVANCE INFORMATION

Group-Input	Source Module-Signal	Group-Input	Source Module-Signal	Group-Input	Source Module-Signal	Group-Input	Source Module-Signal		
G0-5	EPWM5-TRIPOUT	G1-5	EPWM5-SOCA	G2-5	EPWM5-SOCB	G3-5	Unused	G4-5	Unused
G0-6	EPWM6-TRIPOUT	G1-6	EPWM6-SOCA	G2-6	EPWM6-SOCB	G3-6	Unused	G4-6	Unused
G0-7	EPWM7-TRIPOUT	G1-7	EPWM7-SOCA	G2-7	EPWM7-SOCB	G3-7	Unused	G4-7	Unused

Group-Input	Source Module-Signal	Group-Input	Source Module-Signal	Group-Input	Source Module-Signal	Group-Input	Source Module-Signal		
G0-8	EPWM8-TRIPOUT	G1-8	EPWM8-SOCA	G2-8	EPWM8-SOCB	G3-8	Unused	G4-8	Unused
G0-9	EPWM9-TRIPOUT	G1-9	EPWM9-SOCA	G2-9	EPWM9-SOCB	G3-9	Unused	G4-9	Unused
G0-10	EPWM10-TRIPOUT	G1-10	EPWM10-SOCA	G2-10	EPWM10-SOCB	G3-10	Unused	G4-10	Unused

ADVANCE INFORMATION

ADVANCE INFORMATION

Group-Input	Source Module-Signal	Group-Input	Source Module-Signal	Group-Input	Source Module-Signal	Group-Input	Source Module-Signal		
G0-11	EPWM11-TRIPOUT	G1-11	EPWM11-SOCA	G2-11	EPWM11-SOCB	G3-11	Unused	G4-11	Unused
G0-12	EPWM12-TRIPOUT	G1-12	EPWM12-SOCA	G2-12	EPWM12-SOCB	G3-12	Unused	G4-12	Unused
G0-13	EPWM13-TRIPOUT	G1-13	EPWM13-SOCA	G2-13	EPWM13-SOCB	G3-13	Unused	G4-13	Unused

Group-Input	Source Module-Signal	Group-Input	Source Module-Signal	Group-Input	Source Module-Signal	Group-Input	Source Module-Signal		
G0-14	EPWM14-TRIPOUT	G1-14	EPWM14-SOCA	G2-14	EPWM14-SOCB	G3-14	Unused	G4-14	Unused
G0-15	EPWM15-TRIPOUT	G1-15	EPWM15-SOCA	G2-15	EPWM15-SOCB	G3-15	Unused	G4-15	Unused
G0-16	EPWM16-TRIPOUT	G1-16	EPWM16-SOCA	G2-16	EPWM16-SOCB	G3-16	Unused	G4-16	Unused

ADVANCE INFORMATION

ADVANCE INFORMATION

Group-Input	Source Module-Signal	Group-Input	Source Module-Signal	Group-Input	Source Module-Signal	Group-Input	Source Module-Signal		
G0-17	EPWM17-TRIPOUT	G1-17	EPWM17-SOCA	G2-17	EPWM17-SOCB	G3-17	Unused	G4-17	Unused
G0-18	EPWM18-TRIPOUT	G1-18	EPWM18-SOCA	G2-18	EPWM18-SOCB	G3-18	Unused	G4-18	Unused
G0-19	EPWM19-TRIPOUT	G1-19	EPWM19-SOCA	G2-19	EPWM19-SOCB	G3-19	Unused	G4-19	Unused

Group-Input	Source Module-Signal	Group-Input	Source Module-Signal	Group-Input	Source Module-Signal	Group-Input	Source Module-Signal		
G0-20	EPWM20-TRIPOUT	G1-20	EPWM20-SOCBA	G2-20	EPWM20-SOCB	G3-20	Unused	G4-20	Unused
G0-21	EPWM21-TRIPOUT	G1-21	EPWM21-SOCBA	G2-21	EPWM21-SOCB	G3-21	Unused	G4-21	Unused
G0-22	EPWM22-TRIPOUT	G1-22	EPWM22-SOCBA	G2-22	EPWM22-SOCB	G3-22	Unused	G4-22	Unused

ADVANCE INFORMATION

ADVANCE INFORMATION

Group-Input	Source Module-Signal	Group-Input	Source Module-Signal	Group-Input	Source Module-Signal	Group-Input	Source Module-Signal		
G0-23	EPWM23-TRIPOUT	G1-23	EPWM23-SOCA	G2-23	EPWM23-SOCB	G3-23	Unused	G4-23	Unused
G0-24	EPWM24-TRIPOUT	G1-24	EPWM24-SOCA	G2-24	EPWM24-SOCB	G3-24	Unused	G4-24	Unused
G0-25	EPWM25-TRIPOUT	G1-25	EPWM25-SOCA	G2-25	EPWM25-SOCB	G3-25	Unused	G4-25	Unused

Group-Input	Source Module-Signal	Group-Input	Source Module-Signal	Group-Input	Source Module-Signal	Group-Input	Source Module-Signal		
G0-26	EPWM26-TRIPOUT	G1-26	EPWM26-SOCA	G2-26	EPWM26-SOCB	G3-26	Unused	G4-26	Unused
G0-27	EPWM27-TRIPOUT	G1-27	EPWM27-SOCA	G2-27	EPWM27-SOCB	G3-27	Unused	G4-27	Unused
G0-28	EPWM28-TRIPOUT	G1-28	EPWM28-SOCA	G2-28	EPWM28-SOCB	G3-28	Unused	G4-28	Unused

ADVANCE INFORMATION

ADVANCE INFORMATION

Group-Input	Source Module-Signal	Group-Input	Source Module-Signal	Group-Input	Source Module-Signal	Group-Input	Source Module-Signal		
G0-29	EPWM29-TRIPOUT	G1-29	EPWM29-SOCA	G2-29	EPWM29-SOCB	G3-29	Unused	G4-29	Unused
G0-30	EPWM30-TRIPOUT	G1-30	EPWM30-SOCA	G2-30	EPWM30-SOCB	G3-30	Unused	G4-30	Unused
G0-31	EPWM31-TRIPOUT	G1-31	EPWM31-SOCA	G2-31	EPWM31-SOCB	G3-31	Unused	G4-31	Unused

Group-Input	Source Module-Signal	Group-Input	Source Module-Signal	Group-Input	Source Module-Signal	Group-Input	Source Module-Signal	Group-Input	Source Module-Signal		
G5-0	SD0-FILT1CEVT1	G6-0	SD0-FILT1CEVT1	G7-0	SD0-FILT1CEVT1	G8-0	SD0-FILT1CEVT1	G9-0	PWMSYNCOUTXBAR-SYNCOUT0	G10-0	FSIRX0_TRIG0
G5-1	SD0-FILT1CEVT2	G6-1	SD0-FILT1CEVT2	G7-1	SD0-FILT1CEVT2	G8-1	SD0-FILT1CEVT2	G9-1	PWMSYNCOUTXBAR-SYNCOUT1	G10-1	FSIRX0_TRIG0
G5-2	SD0-FILT1COMPZH	G6-2	SD0-FILT1COMPZH	G7-2	SD0-FILT1COMPZH	G8-2	SD0-FILT1COMPZH	G9-2	PWMSYNCOUTXBAR-SYNCOUT2	G10-2	FSIRX0_TRIG0

ADVANCE INFORMATION

ADVANCE INFORMATION

Group-Input	Source Module-Signal	Group-Input	Source Module-Signal	Group-Input	Source Module-Signal	Group-Input	Source Module-Signal	Group-Input	Source Module-Signal		
G5-3	SD0-FILT2CEVT1	G6-3	SD0-FILT2CEVT1	G7-3	SD0-FILT2CEVT1	G8-3	SD0-FILT2CEVT1	G9-3	PWMSYNCOUTXBAR-SYNCOUT3	G10-3	FSIRX0_TRIG0
G5-4	SD0-FILT2CEVT2	G6-4	SD0-FILT2CEVT2	G7-4	SD0-FILT2CEVT2	G8-4	SD0-FILT2CEVT2	G9-4	EQEP0-I_OUT	G10-4	FSIRX0_TRIG1
G5-5	SD0-FILT2COMPZH	G6-5	SD0-FILT2COMPZH	G7-5	SD0-FILT2COMPZH	G8-5	SD0-FILT2COMPZH	G9-5	EQEP0-S_OUT	G10-5	FSIRX0_TRIG1

Group-Input	Source Module-Signal	Group-Input	Source Module-Signal	Group-Input	Source Module-Signal	Group-Input	Source Module-Signal	Group-Input	Source Module-Signal		
G5-6	SD0-FILT3CEVT1	G6-6	SD0-FILT3CEVT1	G7-6	SD0-FILT3CEVT1	G8-6	SD0-FILT3CEVT1	G9-6	EQEP1-I_OUT	G10-6	FSIRX0_TRIG1
G5-7	SD0-FILT3CEVT2	G6-7	SD0-FILT3CEVT2	G7-7	SD0-FILT3CEVT2	G8-7	SD0-FILT3CEVT2	G9-7	EQEP1-S_OUT	G10-7	FSIRX0_TRIG1
G5-8	SD0-FILT3COMPZH	G6-8	SD0-FILT3COMPZH	G7-8	SD0-FILT3COMPZH	G8-8	SD0-FILT3COMPZH	G9-8	EQEP2-I_OUT	G10-8	FSIRX0_TRIG2

ADVANCE INFORMATION

ADVANCE INFORMATION

Group-Input	Source Module-Signal	Group-Input	Source Module-Signal	Group-Input	Source Module-Signal	Group-Input	Source Module-Signal	Group-Input	Source Module-Signal		
G5-9	SD0-FILT4CEVT1	G6-9	SD0-FILT4CEVT1	G7-9	SD0-FILT4CEVT1	G8-9	SD0-FILT4CEVT1	G9-9	EQEP2-S_OUT	G10-9	FSIRX0_TRIG2
G5-10	SD0-FILT4CEVT2	G6-10	SD0-FILT4CEVT2	G7-10	SD0-FILT4CEVT2	G8-10	SD0-FILT4CEVT2	G9-10	ECAP0-OUT	G10-10	FSIRX0_TRIG2
G5-11	SD0-FILT4COMPHZ	G6-11	SD0-FILT4COMPHZ	G7-11	SD0-FILT4COMPHZ	G8-11	SD0-FILT4COMPHZ	G9-11	ECAP1-OUT	G10-11	FSIRX0_TRIG2

Group-Input	Source Module-Signal	Group-Input	Source Module-Signal	Group-Input	Source Module-Signal	Group-Input	Source Module-Signal	Group-Input	Source Module-Signal		
G5-12	SD1-FILT1CEVT1	G6-12	SD1-FILT1CEVT1	G7-12	SD1-FILT1CEVT1	G8-12	SD1-FILT1CEVT1	G9-12	ECAP2-OUT	G10-12	FSIRX0_TRIG3
G5-13	SD1-FILT1CEVT2	G6-13	SD1-FILT1CEVT2	G7-13	SD1-FILT1CEVT2	G8-13	SD1-FILT1CEVT2	G9-13	ECAP3-OUT	G10-13	FSIRX0_TRIG3
G5-14	SD1-FILT1COMPZH	G6-14	SD1-FILT1COMPZH	G7-14	SD1-FILT1COMPZH	G8-14	SD1-FILT1COMPZH	G9-14	ECAP4-OUT	G10-14	FSIRX0_TRIG3

ADVANCE INFORMATION

ADVANCE INFORMATION

Group-Input	Source Module-Signal	Group-Input	Group-Input	Group-Input	Group-Input	Source Module-Signal	Group-Input	Source Module-Signal
G5-15	SD1-FILT2CEVT1	G6-15	G7-15	G8-15	G9-15	ECAP5-OUT	G10-15	FSIRX0_TRIG3
G5-16	SD1-FILT2CEVT2	G6-16	G7-16	G8-16	G9-16	ECAP6-OUT	-	-
G5-17	SD1-FILT2COMPZH	G6-17	G7-17	G8-17	G9-17	ECAP7-OUT	-	-

Group-Input	Source Module-Signal	Group-Input	Source Module-Signal	Group-Input	Source Module-Signal	Group-Input	Source Module-Signal	Group-Input	Source Module-Signal
G5-18	SD1-FILT3CEVT1	G6-18	SD1-FILT3CEVT1	G7-18	SD1-FILT3CEVT1	G8-18	SD1-FILT3CEVT1	G9-18	ECAP8-OUT
G5-19	SD1-FILT3CEVT2	G6-19	SD1-FILT3CEVT2	G7-19	SD1-FILT3CEVT2	G8-19	SD1-FILT3CEVT2	G9-19	ECAP9-OUT
G5-20	SD1-FILT3COMPHZ	-	-	-	-	-	-	-	-
G5-21	SD1-FILT4CEVT1	-	-	-	-	-	-	-	-
G5-22	SD1-FILT4CEVT2	-	-	-	-	-	-	-	-
G5-23	SD1-FILT4COMPHZ	-	-	-	-	-	-	-	-

ADVANCE INFORMATION

7.4.10.6 PWMSYNCOUTXBAR

On this device, the PWM SyncOut x-bar is used to route signals from ePWM(s) sync output(s) to Output x-bar and SoC time sync logic.

The PWM SyncOut x-bar configured by way of the PWMSyncOutXBar[3:0].G0.SEL registers. The available IP sources for each input is shown in PWMSYNCOUTXBAR figure below while the PWM SyncOut x-bar destinations is shown in the table below.

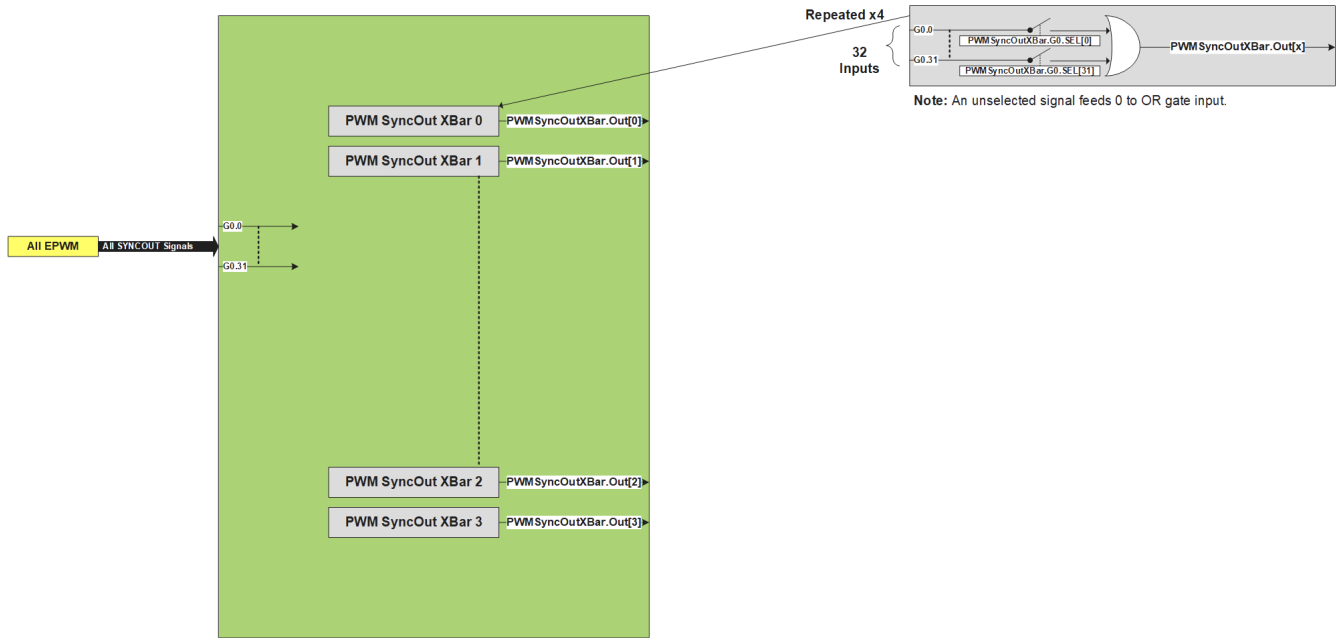

Figure 7-263. pwmsyncout x-bar

PWMSYNCOUXXBAROutputs	Destination-1	Destination-2
PWMSYNCOUXXBAR.Out0	OUTPUTXBAR.G9.0	TIMESYNCXBAR.IN_INTR6
PWMSYNCOUXXBAR.Out1	OUTPUTXBAR.G9.1	TIMESYNCXBAR.IN_INTR7
PWMSYNCOUXXBAR.Out2	OUTPUTXBAR.G9.2	TIMESYNCXBAR.IN_INTR8
PWMSYNCOUXXBAR.Out3	OUTPUTXBAR.G9.3	TIMESYNCXBAR.IN_INTR9

Chapter 8
Interprocessor Communication



This chapter describes the interprocessor communication modules in the device.

8.1 Mailbox

The device provides a mailbox mechanism to asynchronously exchange the messages between any two processors.

Each processor has a mailbox memory space, and registers designated to be used by other processor that wishes to communicate with it.

Each processor has two sets of mailbox memory space and registers, and each set is designated per other processor to communicate with it.

Note

There is an MPU at every Mailbox that may be used to partition the mailbox memory between the Masters/cores. So instead of a fixed allocation, this gives some flexibility.

8.1.1 Mailbox	727
8.1.2 Mailbox Message Scheme	727
8.1.3 Mailbox Message Example	728
8.1.4 Mailbox Registers	728

8.1.1 Mailbox

The device provides a mailbox mechanism to asynchronously exchange the messages between any two processors. Mailbox mechanism is supported across the following processor cores in the device.

Table 8-1. Processor Cores

PROCESSOR NUMBER	PROCESSOR
PROC0	R5SS0_CORE0
PROC1	R5SS0_CORE1
PROC2	R5SS1_CORE0
PROC3	R5SS1_CORE1
PROC4	ICSSM_PRU0
PROC5	ICSSM_PRU1
PROC6	HSM

The mailbox mechanism is achieved by using hardware interrupts generated by the sender processor to the receiver processor. The message payload is placed in shared memory accessible by both the processors.

The device supports two shared memory banks recommended for the purpose of mailbox message payload.

MBOX_SRAM	0x7200 0000	16KB
HSM_MBOX_SRAM	0x4400 0000	2KB

Note

It is not necessary to use the above memory for mailbox. Any shared memory including L2 OCMRAM /TCM can be used for Mailbox payload.

Note

Similar to L2 OCMRAM, there is an MPU in front of MBOX_SRAM that may be used to partition the mailbox memory between the Masters/cores.

8.1.2 Mailbox Message Scheme

The processor which wishes to send a message to another processor writes the message to the mailbox memory space, then interrupts the receiver processor. The receiver processor acknowledges the interrupt, then reads the message from the mailbox memory space. The receiver informs the sender that the message is read by an interrupt, which is acknowledged back by the sender. The sender must not initiate another message to the same receiver until the previously initiated mailbox interaction with the same receiver is complete.

The following sequence is followed for performing a mailbox communication.

1. SENDER Processor writes the message in a shared SRAM space accessible by the RECEIVER Processor.
2. SENDER Processor triggers an interrupt to RECEIVER by writing 1 to <SENDER>_MBOX_WRITE_DONE[RECEIVER].
3. RECEIVER Processor gets a single aggregated interrupt "MBOX_READ_REQ" for all interprocessor communication from all senders.
4. RECEIVER Processor reads the register <RECEIVER>_MBOX_READ_REQ and sees bit [SENDER] is set to 0x1.
5. RECEIVER Processor writes 0x1 to <RECEIVER>_MBOX_READ_REQ[SENDER] to clear the interrupt.
6. RECEIVER Processor reads the message from shared memory.
7. RECEIVER Processor generates an acknowledge interrupt to SENDER Processor by writing 0x1 to <RECEIVER>_MBOX_READ_DONE_ACK[SENDER]
8. SENDER Processor gets a single aggregated interrupt "MBOX_READ_DONE" for all interprocessor communication from all Receivers.

9. SENDER Processor reads the register <SENDER>_MBOX_READ_DONE and sees bit [RECEIVER] is 0x1.
10. SENDER Processor writes 0x1 to <SENDER>_MBOX_READ_DONE [RECEIVER] to clear the interrupt.

Note

The mailbox scheme ensures the number of mailbox interrupts to a processor is always only 2, regardless of the number of processors in the SoC. (**MBOX_READ_REQ** and **MBOX_READ_DONE**)

Note

Every processor is always writing to its own designated mailbox registers.

8.1.3 Mailbox Message Example

Mailbox message example from R5SS0_CORE0 to R5SS1_CORE1:

1. R5SS0_CORE0 writes the message in appropriate shared SRAM (Eg: MBOX_SRAM).
2. R5SS0_CORE0 interrupt to R5SS1_CORE1 by writing 1 to R5SS0_CORE0_MBOX_WRITE_DONE.PROC3.
3. R5SS1_CORE1 gets the interrupt MBOX_READ_REQ. R5SS1_CORE1 reads the register R5SS1_CORE1_MBOX_READ_REQ. and sees the bit PROC0 is 0x1.
4. R5SS1_CORE1 writes to 0x1 to R5SS1_CORE1_MBOX_READ_REQ.PROC0 .
5. R5SS1_CORE1 reads the message.
6. R5SS1_CORE1 writes 0x1 to R5SS1_CORE1_MBOX_READ_DONE_ACK.PROC0 to generate an acknowledgment interrupt to R5SS0_CORE0 .
7. R5SS0_CORE0 gets the interrupt MBOX_READ_DONE. R5SS0_CORE0 reads the register R5SS1_CORE1_MBOX_READ_DONE and sees bit PROC3 is 0x1.
8. R5SS0_CORE0 writes 0x1 to R5SS1_CORE1_MBOX_READ_DONE. PROC3 to clear the interrupt.

8.1.4 Mailbox Registers

Each processor has registers designated for sending and receiving mailbox events. The registers for R5 Cores and ICSSM Cores are present as part of the MSS_CTRL and registers for HSM M4 is present inside HSM.

8.1.4.1 R5SS0_CORE0 Mailbox Registers

The mailbox registers designated for R5SS0_CORE0 are shown in [Table 8-2](#).

Table 8-2. R5SS0_CORE0 Mailbox Registers

REGISTER	Description
R5SS0_CORE0_MBOX_WRITE_DONE	Sender Write Done Register
R5SS0_CORE0_MBOX_READ_REQ	Receiver Read Request Register
R5SS0_CORE0_MBOX_READ_DONE_ACK	Receiver Read Acknowledge Register
R5SS0_CORE0_MBOX_READ_DONE	Sender Read completed Register

8.1.4.2 R5SS0_CORE1 Mailbox Registers

The mailbox registers designated for R5SS0_CORE1 are shown in [Table 8-3](#).

Table 8-3. R5SS0_CORE1 Mailbox Registers

REGISTER	Description
R5SS0_CORE1_MBOX_WRITE_DONE	Sender Write Done Register
R5SS0_CORE1_MBOX_READ_REQ	Receiver Read Request Register
R5SS0_CORE1_MBOX_READ_DONE_ACK	Receiver Read Acknowledge Register
R5SS0_CORE1_MBOX_READ_DONE	Sender Read completed Register

8.1.4.3 R5SS1_CORE0 Mailbox Registers

The mailbox registers designated for R5SS1_CORE0 is shown in [Table 8-4](#).

Table 8-4. R5SS1_CORE0 Mailbox Registers

REGISTER	Description
R5SS1_CORE0_MBOX_WRITE_DONE	Sender Write Done Register
R5SS1_CORE0_MBOX_READ_REQ	Receiver Read Request Register
R5SS1_CORE0_MBOX_READ_DONE_ACK	Receiver Read Acknowledge Register
R5SS1_CORE0_MBOX_READ_DONE	Sender Read completed Register

8.1.4.4 R5SS1_CORE1 Mailbox Registers

The mailbox registers designated for R5SS1_CORE1 are shown in [Table 8-5](#).

Table 8-5. R5SS1_CORE1 Mailbox Registers

REGISTER	Description
R5SS1_CORE1_MBOX_WRITE_DONE	Sender Write Done Register
R5SS1_CORE1_MBOX_READ_REQ	Receiver Read Request Register
R5SS1_CORE1_MBOX_READ_DONE_ACK	Receiver Read Acknowledge Register
R5SS1_CORE1_MBOX_READ_DONE	Sender Read completed Register

8.1.4.5 ICSSM_PRU0 Mailbox Registers

The mailbox registers designated for ICSSM_PRU0 is shown in [Table 8-6](#).

Table 8-6. ICSSM_PRU0 Mailbox Registers

REGISTER	Description
ICSSM_PRU0_MBOX_WRITE_DONE	Sender Write Done Register
ICSSM_PRU0_MBOX_READ_REQ	Receiver Read Request Register
ICSSM_PRU0_MBOX_READ_DONE_ACK	Receiver Read Acknowledge Register
ICSSM_PRU0_MBOX_READ_DONE	Sender Read completed Register

8.1.4.6 ICSSM_PRU1 Mailbox Registers

The mailbox registers designated for ICSSM_PRU1 is shown in [Table 8-7](#).

Table 8-7. ICSSM_PRU1 Mailbox Registers

REGISTER	Description
ICSSM_PRU1_MBOX_WRITE_DONE	Sender Write Done Register
ICSSM_PRU1_MBOX_READ_REQ	Receiver Read Request Register
ICSSM_PRU1_MBOX_READ_DONE_ACK	Receiver Read Acknowledge Register
ICSSM_PRU1_MBOX_READ_DONE	Sender Read completed Register

8.1.4.7 HSM Mailbox Registers

The mailbox registers designated for HSM are shown in [Table 8-8](#).

Table 8-8. HSM Mailbox Registers

REGISTER	Description
HSM_MBOX_WRITE_DONE	Sender Write Done Register
HSM_MBOX_READ_REQ	Receiver Read Request Register
HSM_MBOX_READ_DONE_ACK	Receiver Read Acknowledge Register
HSM_MBOX_READ_DONE	Sender Read completed Register

8.2 Spinlock

This chapter describes the Spinlock module of the device.

8.2.1 Spinlock Overview	731
8.2.2 Spinlock Integration	732
8.2.3 Spinlock Functional Description	733
8.2.4 Spinlock Programming Guide	735

8.2.1 Spinlock Overview

The Spinlock module provides hardware assistance for synchronizing the processes running on multiple processors in the device.

The Spinlock module implements 256 spinlocks (or hardware semaphores), which provide an efficient way to perform a lock operation of a device resource using a single read-access, avoiding the need of a read-modify-write bus transfer that the programmable cores are not capable of.

Figure 8-1 shows an overview of the Spinlock module.

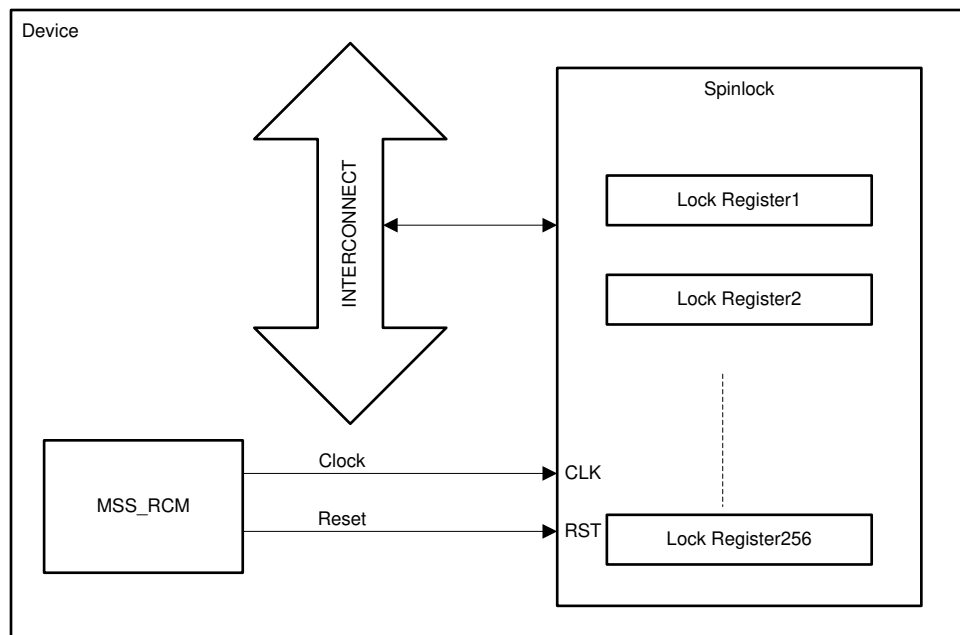

Figure 8-1. Spinlock Overview

8.2.1.1 Spinlock Not Supported Features

The following features are not supported by the module:

- Ownership enforcement. There is no support to ensure that a lock register is locked and unlocked by the same process
- There is no support for checking that the same VBUS initiator that acquired the lock is the one that is freeing the lock
- There is no support for fairness or congestion control.

8.2.2 Spinlock Integration

This section describes module integration in the device, including information about clocks, resets, and hardware requests.

AM263x Spinlock Integration

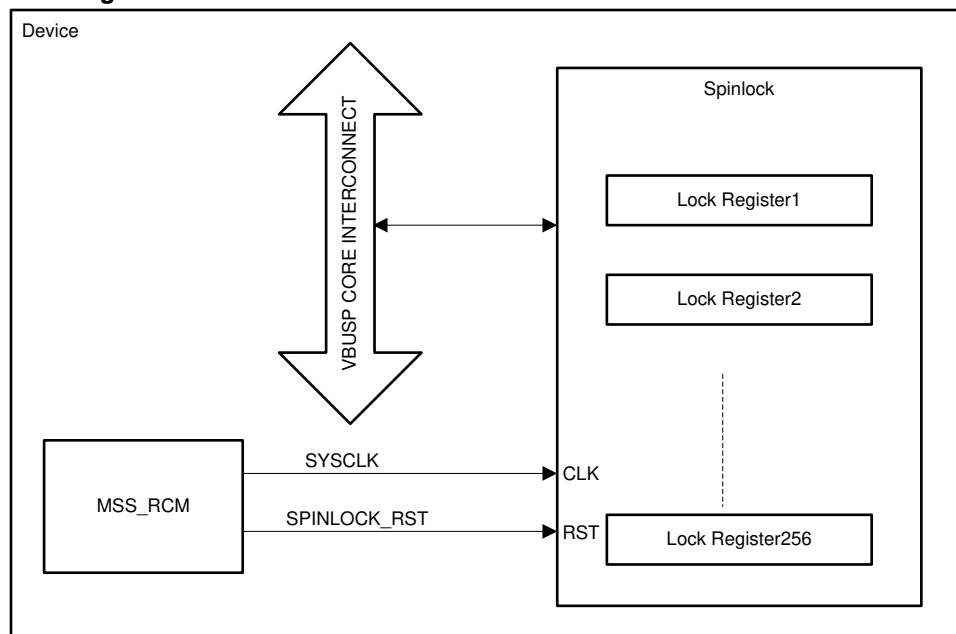

Figure 8-2. SPINLOCK Integration

Table 8-9. SPINLOCK Integration Attributes

Module Instance	SoC Interconnect
SPINLOCK	VBUSP CORE Interconnect

Table 8-10. SPINLOCK Clocks

Module Instance	Module Clock Input	Source Clock Signal	Source	Description
SPINLOCK	CLK	SYSCLK	MSS_RCM	SPINLOCK Functional and Interface clock

Table 8-11. SPINLOCK Resets

Module Instance	Module Reset Input	Source Reset Signal	Source	Description
SPINLOCK	RST	SPINLOCK_RSTN	MSS_RCM	SPINLOCK Reset

Table 8-12. SPINLOCK Interrupt Requests

Module Instance	Module Interrupt Signal	Destination Interrupt Input	Destination	Description	Type
SPINLOCK0	-	-	-	No interrupts to external processors	-

Table 8-13. SPINLOCK DMA Requests

Module Instance	Module DMA Event	Destination DMA Event Input	Destination	Description	Type
SPINLOCK0	-	-	-	No EDMA Requests	-

8.2.3 Spinlock Functional Description

8.2.3.1 Spinlock Software Reset

The Spinlock module can be reset by software through the SPINLOCK_SYSCONFIG[1] SOFTRESET bit. Setting this bit to 1 enables an active software reset that is functionally equivalent to a hardware reset. The SPINLOCK_SYSTATUS[0] RESETDONE bit can be polled to check the reset status (reading 1 indicates that reset sequence is done; reading 0 indicates that reset sequence is in progress). The software must ensure that the software reset completes before doing Spinlock operations.

8.2.3.2 About Spinlocks

Spinlocks are present to solve the need for synchronization and mutual exclusion between heterogeneous processors and those not operating under a single, shared operating system. There is no alternative mechanism to accomplish these operations between processors in separate subsystems.

Spinlocks are not the best way to synchronize between tasks or threads on one CPU. Instead, spinlocks are for use in synchronization between different subsystems in the device that don't have any other means of hardware-based synchronization.

Spinlocks do not solve all system synchronization issues. They have limited applicability and should be used with care to implement higher level synchronization protocols.

A spinlock is appropriate for mutual exclusion for access to a shared data structure. It should be used only when:

1. The time to hold the lock is predictable and small (for example, a maximum hold time of less than 200 CPU cycles may be acceptable).
2. The locking task cannot be preempted, suspended, or interrupted while holding the lock (this would make the hold time large and unpredictable).
3. The lock is lightly contended, that is the chance of any other process (or processor) trying to acquire the lock while it is held is small.

If these conditions are met, then the locking code can retry a failed attempt to acquire the lock until success.

If the conditions are not met, then a spinlock is not a good candidate. One alternative is to use a spinlock for critical section control (engineered to meet the conditions) to implement a higher level semaphore that can support preemption, notification, timeout or other higher level properties.

8.2.3.3 Spinlock Functional Operation

The Spinlock module supports 256 spinlocks. It accepts only a single command at a time and processes the command fully before accepting the next command. A lock is requested by reading the SPINLOCK_LOCK_REG_i[0] TAKEN bit. There are two states: Taken (SPINLOCK_LOCK_REG_y[0] TAKEN = 1) or Not Taken (SPINLOCK_LOCK_REG_y[0] TAKEN = 0), where y = 0h to FFh.

When the status of lock y (where y = 0 to 255) is Not Taken (free), a read from the SPINLOCK_LOCK_REG_y register returns 0 and sets the lock to Taken (locked). When the status of lock y is Taken, a read returns 1 and does not change the state of the lock.

A write to the SPINLOCK_LOCK_REG_y register does not change the state of lock, unless when writing 0 when the lock is in Taken state. By doing this, the requester frees the lock.

Figure 8-3 shows the SPINLOCK_LOCK_REG_y register state diagram.

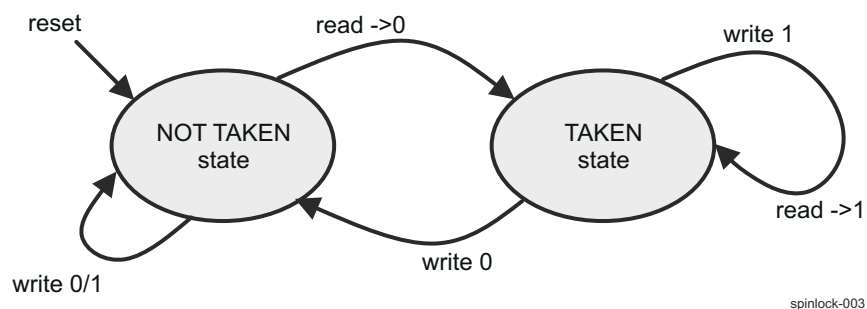
Figure 8-3. Lock Register State Diagram
Note

- There is no support to ensure that a lock register is locked and unlocked by the same process. This must be ensured in software.
- There is no support to check that the same initiator that acquired the lock is the one that is freeing the lock.

8.2.4 Spinlock Programming Guide

8.2.4.1 Spinlock Low-level Programming Models

This section covers the low-level hardware programming sequences for configuration and usage of the module.

8.2.4.1.1 Basic Spinlock Operations

The main Spinlock operations are:

- Clear all the Taken spinlocks (only after a system bug recovery)
- Take a spinlock
- Release spinlock

8.2.4.1.1.1 Spinlocks Clearing After a System Bug Recovery

Module initialization (after reset) is not needed, except after system bug recovery. The following table presents the Spinlock initialization after a system bug recovery. Software should store 0 into each of the SPINLOCK_LOCK_REG_y registers at system startup to insure that all locks are initialized to Not Taken.

Table 8-14. Spinlock System Bug Recovery

Step	Register	Value
IF: SPINLOCK_SYSTATUS[0] IU0 = 1?	SPINLOCK_SYSTATUS[0] IU0	=1
Free the 256 locks	SPINLOCK_LOCK_REG_y[0] TAKEN (y = 0 to 255)	0x0
END		

8.2.4.1.1.2 Take and Release Spinlock

This procedure configures the take and release (free) operations for the Spinlock module. A spinlock should only be held with interrupts disabled. So, before attempting to obtain the spinlock, software must disable interrupts. Then it must read the [0] TAKEN bit to attempt to obtain the lock. If it succeeds, it must proceed directly through the critical section then unlock and re-enable interrupts. If the acquisition attempt fails, the acquisition must be reattempted. To prevent unknown interrupt disabled time, interrupts must be re-enabled and then disabled before reattempting to acquire the lock. [Figure 8-4](#) shows the described above procedure.

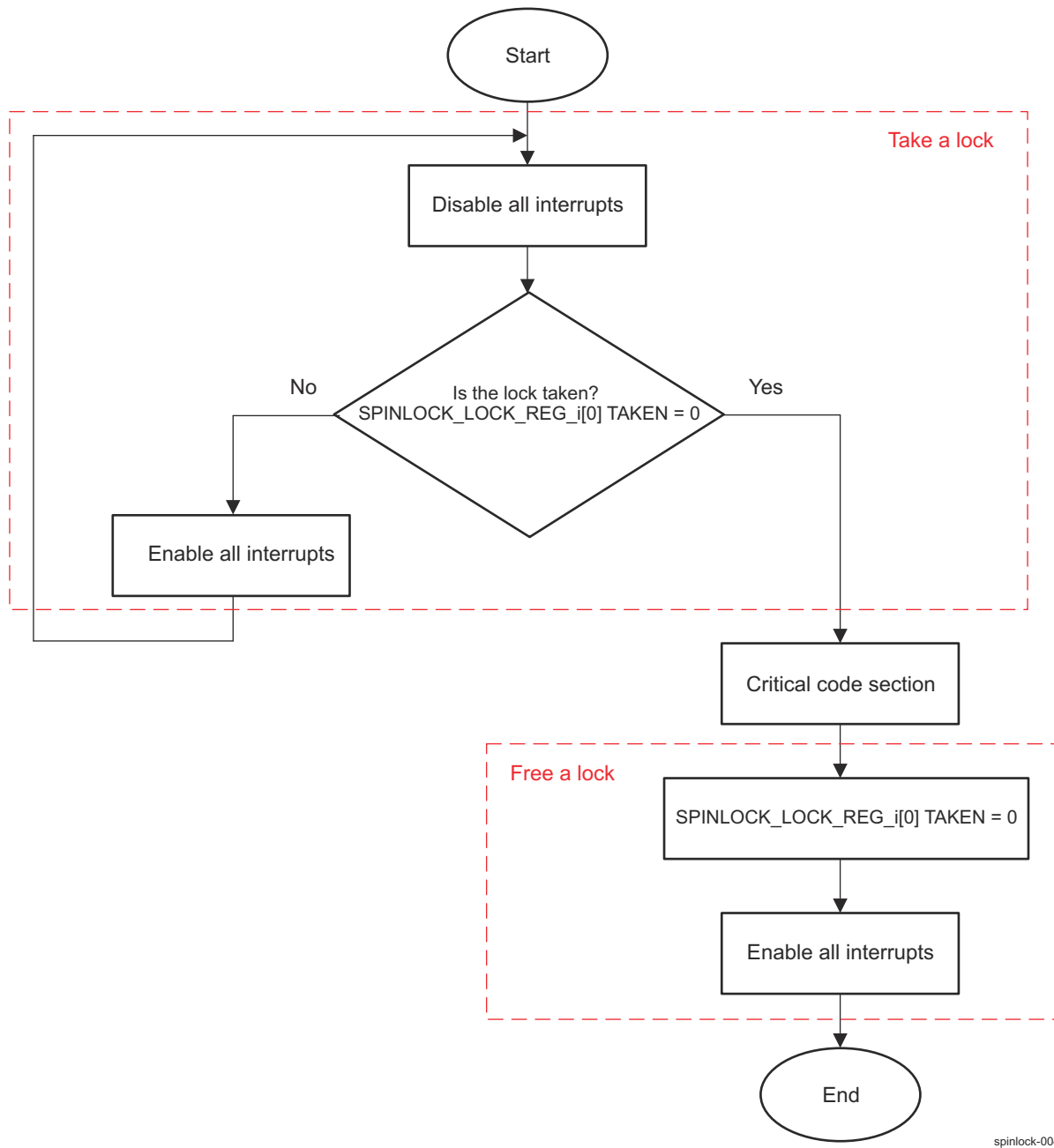

spinlock-004

Figure 8-4. Take and Release Spinlock

Table 8-15. Register Call Summary

Register Name
[0] TAKEN

Table 8-16. Subprocess Call Summary

Subprocess Name	Description
Disable (Mask) All Interrupts	For information about disabling/enabling all interrupts in an Arm® processor, refer to Arm <i>Technical Reference Manual</i> , available at infocenter.arm.com/help/index.jsp .
Enable (Unmask) All Interrupts	For information about disabling/enabling all interrupts in other processors, refer to the corresponding processor chapter.

Chapter 9
Memory Controllers



This chapter describes the memory controllers in the device.

9.1 Memory Controllers Overview.....	738
---	------------

9.1 Memory Controllers Overview

The AM263x family of devices utilize an integrated On-Chip Static Random Access Memory (OCSRAM). Controllers for external memory sources such as DDR are not included. The key functionality of the OCSRAM module includes:

- Total of up to 2MB of RAM
 - Can be used as code and data memory by the R5FSS cores
 - Can be used as data buffers accessible by EDMA
- Four 64-bit wide independent banks of size 512KB with 200Mhz operating frequency
- Accessible by all initiator modules via the CORE_CBASS interconnect
- Protected with MPU firewalls
- 64-bit ECC Support
 - Read-Modify-Write mechanism to support ECC update on memory writes less then 64-bits. Read-Modify-Write operation works independently per bank and requires one additional cycle to update.



This chapter describes the interrupts in the device.

10.1 Interrupt Architecture.....	740
10.2 Interrupt Controllers.....	740
10.3 Interrupt Routers.....	748
10.4 Interrupt Sources.....	764

10.1 Interrupt Architecture

The SoC has many peripherals and a large number of event sources including interrupts, time sync events, and DMA requests. The use of events is completely dependent on a user's specific application, which drives a need for maximum flexibility on which event sources are used in the system. Software control must be used to service these events.

The SoC includes the following interrupt servicing modules (hosts):

- 2x Real-time microcontroller units (R5FSS0, R5FSS1), each supporting:
 - Dual-R5F Cluster
 - Vectored interrupt manager (VIM)
- Hardware Security Module (HSM)
 - Single Arm Cortex-M4F core
 - Nested vectored interrupt controller (NVIC)
- Industrial communications subsystem (PRU_ICSSM0):
 - Two programmable real-time units (PRUs)
 - Local interrupt controller (INTC)

Most of the system events are routed directly to the various processing elements but in some cases it is impractical to route all events of a certain group (for example, GPIO events) to each processing element. For this purpose, the SoC integrates several interrupt router (INTRTR) instances. Each interrupt router aggregates a number of system events and can route each event to a given processing element by using simple combinational logic (implemented via a set of multiplexors). Event selection is controlled through the associated registers within each interrupt router.

The following interrupt router instances are part of the SoC interrupt architecture:

- GPIO XBAR Interrupt Router (GPIO_XBAR_INTRTR0):
 - Provides selection of active GPIO[0:3] module interrupts
 - Supported by dedicated device GPIO muxing that provides virtualization
- ICSSM XBAR Interrupt Router (ICSSM_XBAR_INTRTR0):
 - Provides selection of active ICSSM XBAR events for routing as processor interrupts or DMA events
- EDMA Trigger XBAR Interrupt Router (EDMA_XBAR_INTRTR0):
 - Provides selection of DMA Trigger events from various device peripherals

In addition, the following interrupt router instances are part of the SoC time sync architecture:

- SoC Time Sync Event Router (SOC_TIMESYNC_INTRTR0):
 - Provides selection of active SoC (non-CONTROLSS) peripherals time synchronization events for routing to other time sync capable modules
- CONTROLSS Time Sync Event Router (CONTROLSS_TIMESYNC_INTRTR0):
 - Provides selection of active CONTROLSS peripherals time synchronization events for routing to other time sync capable modules

10.2 Interrupt Controllers

10.2.1 Vectored Interrupt Manager (VIM)

10.2.1.1 VIM Overview

The VIM aggregates device interrupts and sends them to the R5F CPU(s). It can be used in either split or single-core configuration.

The VIM module supports the following features:

- 256 interrupt inputs per R5F core
- Each interrupt has its own 4-bit programmable priority
 - Defined via the R5FSS_VIM_PRI_INT_j register

- The VIM provides support for priority interruption of interrupts
- Each interrupt has its own enable mask
 - Interrupt enable is done via the R5FSS_VIM_INTR_EN_SET_j register
 - Interrupt disable is done via the R5FSS_VIM_INTR_EN_CLR_j register
- Each interrupt can be programmed as either an IRQ or FIQ
 - Defined via the R5FSS_VIM_INTMAP_j register
- Each interrupt has its own programmable 32-bit vector address associated with it
 - Defined via the R5FSS_VIM_VEC_INT_j register
 - Protected with SECEDED
- One IRQn and one FIQn output per core
- Vectored interrupt interface
 - Compatible with R5F VIC port
- Default vector provided when a double-bit error is detected
- Split or single-core capable
 - In single-core mode, only interrupts connected to VIM interrupt core 0 are available
- Software interrupt generation

10.2.1.2 VIM Interrupt Inputs

The VIM supports 256 interrupt inputs per core. Each interrupt can be either a level or a pulse (both active-high). The interrupt mapping for the two R5F cores can be found in *Interrupt Sources*.

10.2.1.3 VIM Interrupt Outputs

The VIM has two interrupt outputs per core:

- *CoreN_IRQn*: This is a normal interrupt for core *N* (active-low level). It can be serviced via the VIC interface or through the MMR interface. Whenever an interrupt input goes high, if that interrupt is mapped as an IRQ (via the register) and is enabled (via the register), then it will cause an IRQ to assert
- *CoreN_FIQn*: This is a fast (or non-maskable) interrupt for core *N* (active-low level). FIQs always have priority over IRQs. An FIQ can be serviced through the MMR interface. Whenever an interrupt input goes high, if that interrupt is mapped as an FIQ and is enabled, then it will cause an FIQ to assert

10.2.1.4 VIM Interrupt Vector Table (VIM RAM)

For each VIM interrupt core, there is an associated interrupt vector table (VIM RAM) that is used to store the address of ISRs. During register vectored interrupt and hardware vectored interrupt, VIM accesses the interrupt vector table using the vector value to fetch the address of the corresponding ISR. Note that both interrupt vector tables are identical in their memory organization.

The VIM RAM is basically comprised of a set of interrupt vector registers (R5FSS_VIM_VEC_INT_j). Hence, the interrupt vector table is organized in 256 words of 30 bits, with a base address corresponding to the physical address of the first register in the group.

Note

The lower two bits of the 32-bit interrupt vector are always 0s.

Figure 10-1 shows the VIM RAM interrupt vector map.

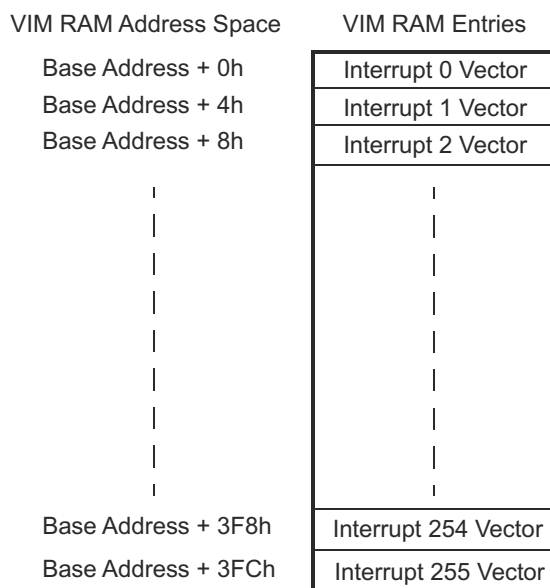
Figure 10-1. VIM RAM Interrupt Vector Map

The interrupt vector table has protection by ECC to indicate corruption due to soft errors. The ECC logic inside VIM supports SECDED. See [Table 7-10](#) for the VIM RAM ID in the ECC aggregator map.

10.2.1.5 VIM Interrupt Prioritization

The VIM supports the interruption of the currently active interrupt by one with a higher priority. FIQs and IRQs are completely separate but both use the same mechanism.

Note

VIM priority scheme: 00 = Highest Priority - 15 = Lowest Priority

When an interrupt goes from pending to active (FIQ: reading the R5FSS_VIM_FIQVEC register; IRQ: reading the R5FSS_VIM_IRQVEC register, or the *coreN_IRQACK* going high), then the interrupt is loaded into the corresponding active register (R5FSS_VIM_ACTFIQ / R5FSS_VIM_ACTIRQ), and all interrupts of an equal or lesser priority are masked (discarded). If prior to this interrupt being cleared (by writing to the R5FSS_VIM_FIQVEC register, or R5FSS_VIM_IRQVEC register) another interrupt of higher priority arrives, then the FIQn/IRQn is asserted and that interrupt made pending as normal. If the CPU switches this interrupt to active (by reading the R5FSS_VIM_FIQVEC / R5FSS_VIM_IRQVEC register), then the currently active interrupt is pushed onto a stack. When an interrupt is cleared by reading the R5FSS_VIM_FIQVEC / R5FSS_VIM_IRQVEC register, if there are any interrupts on the stack, the first entry is popped off and put back into the R5FSS_VIM_ACTFIQ / R5FSS_VIM_ACTIRQ register, so that software retains original context and continues previous operation.

Note

"Masked off" means that the registers are masked off from priority arbitration to interrupt the currently active interrupt, this does *not* mean that the status bits in the registers are masked off. That is, this priority masking has NO EFFECT on whether the status bits are visible in the masked registers such as the Group M Interrupt Enabled Status/Clear Register.

10.2.1.6 VIM ECC Support

The memory that holds the interrupt vector for each interrupt is protected by SECDED ECC. Single-bit errors are corrected and written back. Double-bit errors are not corrected. If a double-bit error occurs while trying to load a vector, then the R5FSS_VIM_DEDVEC register is used to provide the default vector for the *coreN_IRQADDRV*

signal, the R5FSS_VIM_IRQVEC register, and the R5FSS_VIM_FIQVEC register. The R5FSS_VIM_DEDVEC should point to an ISR that handles the fact that there was an uncorrectable error in the interrupt handling.

Some possible remediating actions would be to:

1. Reconstruct the vector table and re-start the application
 - a. Potentially switch to a completely software interrupt handler in the mean time
2. Restart the application from scratch
3. Reset the device
4. Sit in a loop (or WFI) while something external (for example, the ESM) responds to the DED interrupt that will be generated

It is up to the user and the application to determine the appropriate action.

Note

An interrupt that has an uncorrectable vector error (and thus uses the DED vector) will still have the priority of the original interrupt. This makes it possible for a higher priority interrupt to supercede the handling of the error.

Control and reporting are done by the R5FSS ECC aggregator.

10.2.1.7 VIM IDLE State

The VIM will indicate IDLE when there are no pending unmasked interrupts or MMR accesses. The VIM does not have a clock stop interface.

10.2.1.8 VIM Interrupt Handling

There are multiple ways to service an interrupt depending on how much of the hardware assistance offered by the VIM the software wants to take advantage of.

For IRQs, it is recommended to use the procedure in [Section 10.2.1.8.1](#), but the procedures in [Section 10.2.1.8.2](#) or [Section 10.2.1.8.3](#) (if a user wants to implement a fully software prioritization scheme) may be used as alternatives.

For FIQs, it is recommended to use the procedure in [Section 10.2.1.8.4](#), but the procedure in [Section 10.2.1.8.5](#) may be used as an alternative.

Note

These descriptions do not include steps such as stack pushes and state retention that software must take in order to return from the ISR. It is assumed that the programmer is aware of these steps.

10.2.1.8.1 Servicing IRQ Through Vector Interface

If the associated CPU has the vector (VIC) interface enabled, then the following method is used for servicing IRQs:

1. Hardware handshake
 - a. CPU asserts *coreN_IRQACK* high
 - b. VIM asserts *coreN_IRQADDRV* to indicate that the *coreN_IRQADDR* bus is stable with the correct vector address
 - c. CPU reads *coreN_IRQADDR*, jumps to that address, and de-asserts *coreN_IRQACK* low
 - d. VIM de-asserts *coreN_IRQn* and *coreN_IRQADDRV*, VIM masks (discards) all IRQs with the same or lower priority
 - e. VIM loads the value from the R5FSS_VIM_PRIIRQ[9:0] NUM bit field (which corresponds to the vector address) into the R5FSS_VIM_ACTIRQ[9:0] NUM bit field, which causes the R5FSS_VIM_ACTIRQ[31] VALID bit to be set
2. Service the interrupt

3. Depending on whether the original source of the interrupt was a pulse or a level (determined by reading the R5FSS_VIM_ACTIRQ[9:0] NUM bit field to determine number, and reading the appropriate bit in the R5FSS_VIM_INTTYPE_j register to determine type)
 - a. Pulse
 - i. Clear the status by writing a '1' to the appropriate bit in the R5FSS_VIM_IRQSTS_j register, or R5FSS_VIM_STS_j register
 - ii. Clear the interrupt at the source. This way, the source can generate another pulse, if it needs to, and the VIM will process this as a new interrupt
 - b. Level
 - i. Clear the interrupt at the source
 - ii. Clear the status by writing a '1' to the appropriate bit in the R5FSS_VIM_IRQSTS_j register, or R5FSS_VIM_STS_j register. This way, the level should be gone at the input to the VIM, it will avoid falsely re-calling the interrupt. If the source maintains the level, then it means there is another interrupt
4. Write any value to the R5FSS_VIM_IRQVEC register
 - a. This will clear the priority mask and will cause all interrupts to be re-evaluated for the new highest priority interrupt
 - b. This will also clear the R5FSS_VIM_ACTIRQ[31] VALID bit

10.2.1.8.2 Servicing IRQ Through MMR Interface

When an IRQ interrupt is received, the CPU should follow these steps if not using the vector interface:

1. Read the R5FSS_VIM_IRQVEC register and jump to that address to service the ISR
 - a. Reading this register will mask (discard) all interrupts of an equal or lower priority and de-assert the *coreN_IRQn* output. If another interrupt of a higher priority becomes available, the *coreN_IRQn* will re-assert, allowing priority interruption of an interrupt
 - b. Reading this register will cause the value from the R5FSS_VIM_PRIIRQ[9:0] NUM bit field to be loaded into the R5FSS_VIM_ACTIRQ[9:0] NUM bit field, and the R5FSS_VIM_ACTIRQ[31] VALID bit to be set
2. Service the interrupt
3. Depending on whether the original source of the interrupt was a pulse or a level
 - a. Pulse
 - i. Clear the status by writing a '1' to the appropriate bit in the R5FSS_VIM_STS_j register, or R5FSS_VIM_IRQSTS_j register
 - ii. Clear the interrupt at the source
 - b. Level
 - i. Clear the interrupt at the source
 - ii. Clear the status by writing a '1' to the appropriate bit in the R5FSS_VIM_STS_j register, or R5FSS_VIM_IRQSTS_j register
4. Write any value to the R5FSS_VIM_IRQVEC register
 - a. This will clear the priority mask and will cause all interrupts to be re-evaluated for the new highest priority interrupt
 - b. This will also clear the R5FSS_VIM_ACTIRQ[31] VALID bit

10.2.1.8.3 Servicing IRQ Through MMR Interface (Alternative)

If a user does not want to use the R5FSS_VIM_IRQVEC register, the VIM may be used as a more traditional interrupt controller. Note that in this mode, there is no hardware priority masking (because the R5FSS_VIM_IRQVEC register is never read). Software would be responsible for doing all priority operations.

1. Determine which interrupt to service
 - a. Read the R5FSS_VIM_PRIIRQ register to determine which interrupt is the highest priority IRQ currently asserted, OR
 - b. Optionally read the R5FSS_VIM_IRQGSTS register to determine which groups have IRQs pending, then read the R5FSS_VIM_IRQSTS_j register and use a software prioritization scheme to determine which IRQ to service
2. Service the interrupt

3. Depending on whether the original source of the interrupt was a pulse or a level
 - a. Pulse
 - i. Clear the status by writing a '1' to the appropriate bit in the R5FSS_VIM_STS_j register, or R5FSS_VIM_IRQSTS_j register
 - ii. Clear the interrupt at the source.
 - b. Level
 - i. Clear the interrupt at the source
 - ii. Clear the status by writing a '1' to the appropriate bit in the R5FSS_VIM_STS_j register, or R5FSS_VIM_IRQSTS_j register

10.2.1.8.4 Servicing FIQ

When an FIQ interrupt is received, the CPU should follow these steps:

1. Read the R5FSS_VIM_FIQVEC register and jump to that address to service the ISR
 - a. Reading this register will mask (discard) all interrupts of an equal or lower priority and de-assert the *coreN_FIQn* output. If another interrupt of a higher priority becomes available, the *coreN_FIQn* will re-assert, allowing priority interruption of an interrupt.
 - b. Reading this register will cause the value from the R5FSS_VIM_PRIFIQ[9:0] NUM bit field to be loaded into the R5FSS_VIM_ACTFIQ[9:0] NUM bit field, and the R5FSS_VIM_ACTFIQ[31] VALID bit to be set
2. Service the interrupt
3. Depending on whether the original source of the interrupt was a pulse or a level (determined by reading the R5FSS_VIM_ACTFIQ[9:0] NUM bit field to determine number, and reading the appropriate bit in the R5FSS_VIM_INTTYPE_j register to determine type)
 - a. Pulse
 - i. Clear the status by writing a '1' to the appropriate bit in the R5FSS_VIM_STS_j register, or R5FSS_VIM_FIQSTS_j register
 - ii. Clear the interrupt at the source. This way, the source can generate another pulse, if it needs to, and the VIM will process this as a new interrupt
 - b. Level
 - i. Clear the interrupt at the source
 - ii. Clear the status by writing a '1' to the appropriate bit in the R5FSS_VIM_STS_j register, or R5FSS_VIM_FIQSTS_j register. This way, the level should be gone at the input to the VIM, it will avoid falsely re-calling the interrupt. If the source maintains the level, then it means there is another interrupt
4. Write any value to the R5FSS_VIM_FIQVEC register
 - a. This will clear the priority mask and will cause all interrupts to be re-evaluated for the new highest priority interrupt
 - b. This will also clear the R5FSS_VIM_ACTFIQ[31] VALID bit

10.2.1.8.5 Servicing FIQ (Alternative)

If a user does not want to use the R5FSS_VIM_FIQVEC register, the VIM may be used as a more traditional interrupt controller. Note that in this mode, there is no hardware priority masking (because the R5FSS_VIM_FIQVEC register is never read). Software would be responsible for doing all priority operations.

1. Determine which interrupt to service
 - a. Read the R5FSS_VIM_FIQVEC register to determine which interrupt is the highest priority FIQ currently asserted, OR
 - b. Optionally read the R5FSS_VIM_FIQGSTS register to determine which groups have IRQs pending, then read the R5FSS_VIM_FIQSTS_j register and use a software prioritization scheme to determine which FIQ to service
2. Service the interrupt
3. Depending on whether the original source of the interrupt was a pulse or a level
 - a. Pulse
 - i. Clear the status by writing a '1' to the appropriate bit in the R5FSS_VIM_STS_j register, or R5FSS_VIM_FIQSTS_j register

- ii. Clear the interrupt at the source.
- b. Level
 - i. Clear the interrupt at the source
 - ii. Clear the status by writing a '1' to the appropriate bit in the R5FSS_VIM_STS_j register, or R5FSS_VIM_FIQSTS_j register.

10.2.2 Other Interrupt Controllers

All other device interrupt controllers are described in their respective chapters and/or third party documentation.

10.3 Interrupt Routers

10.3.1 INTRTR Overview

The interrupt router (INTRTR) module provides a mechanism to mux M interrupt inputs to N interrupt outputs, where all M inputs are selectable to be driven per N output. There is one register per output (MUXCNTL_N) that controls the selection.

There are several INTRTR modules in the device. Their purpose is described in [Section 10.1, Interrupt Architecture](#). [#unique_961/unique_961_Connect_42_J7_INTRTR_CFG_TBL](#) summarizes the configuration details for the various interrupt routers.

Table 10-1. INTRTR Modules Configuration

Module	Number of Inputs	Number of Outputs	Input Interrupt Type
GPIO_XBAR_INTRTR0	180	30 ¹	Pulse
ICSSM_XBAR_INTRTR0	60	16	Pulse
EDMA_XBAR_INTRTR0			
SOC_TIMESYNC_INTRTR0	16	26 ¹	Pulse
CONTROLSS_TIMESYNC_INTRTR0	128	32	Pulse

. CONTROLSS_INTXBAR is described in chapter in CONTROLSS and SOC_TSXBAR_INTR are captured in TimeSync Event Sources.

1. Only 4 outputs from GPIO_XBAR_INTRTR0 & SOC_TIMESYNC_INTRTR0 connect to each VIM[3:0] instance

The user should take the following into account when programming the MUXCNTL_N register:

- Avoid programming this register when input interrupts are active. This could lead to spurious asynchronous output toggles which may lead to unpredictable behavior.
- All mux control settings default to '0', which means that at reset no input interrupt will be propagated to any of the INTRTR outputs. This is due to the fact that the 0th input of all internal muxes is unused in the current implementation

The recommended general programming sequence is as follows:

1. Disable interrupt by writing '0' to the INT_ENABLE bit field. Do not change mux control configuration settings (ENABLE bit field) at this time.
2. Change the mux control configuration settings. INT_ENABLE needs to remain '0' at this time.
3. Enable interrupt by writing '1' to INT_ENABLE. Do not change mux control configuration settings at this time.

10.3.2 INTRTR Integration

This section describes the INTRTR integration in the device, including information about clocks, resets, and hardware requests.

10.3.2.1 PRU-ICSS XBAR INTRTR0

There is 1x PRU-ICSS XBAR Interrupt Router module integrated in the device. The diagram below provides a visual representation of the device integration details for the PRU-ICSS XBAR Interrupt Router.

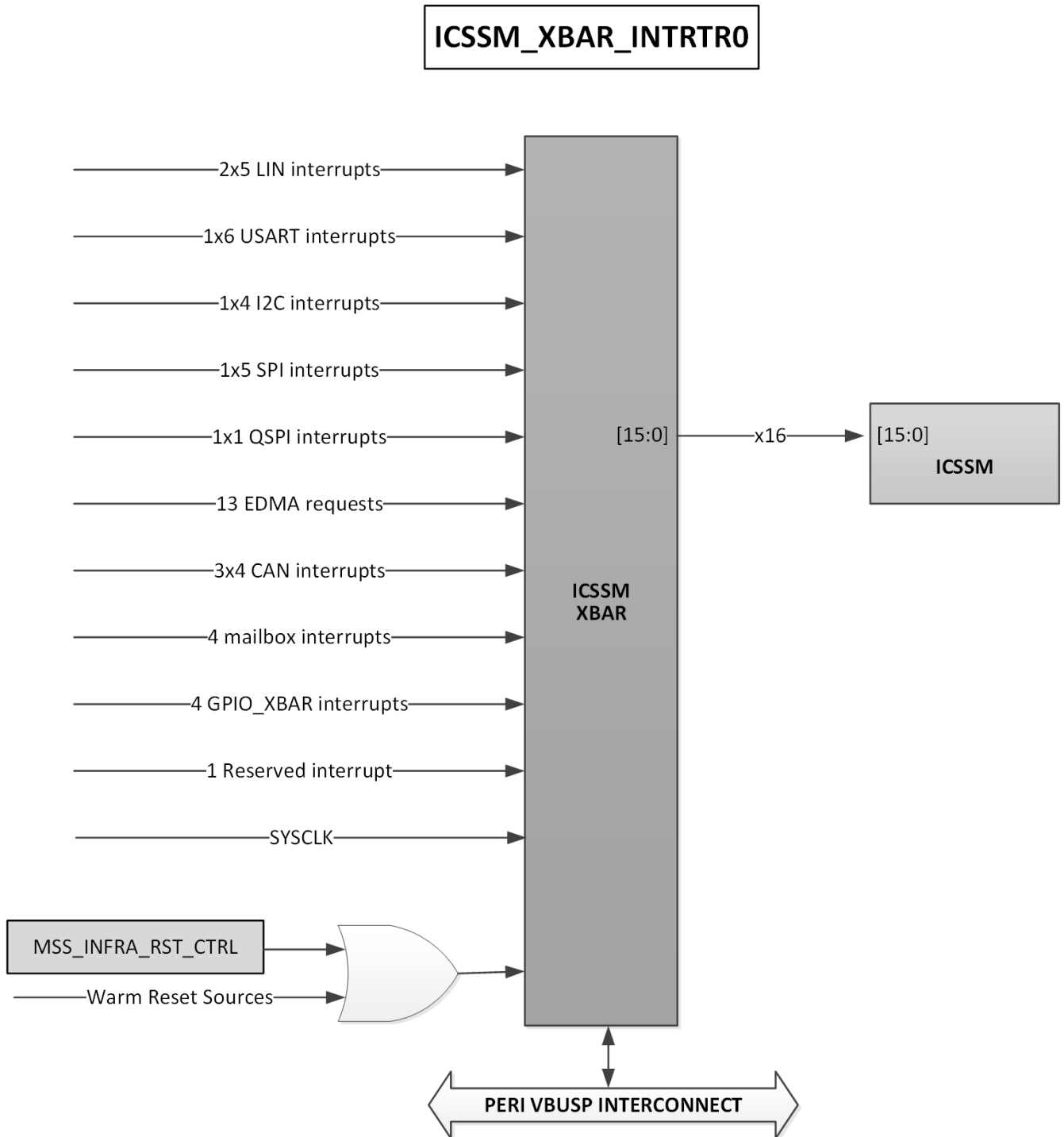

Figure 10-2. PRU-ICSS XBAR Interrupt Router Integration Diagram

The tables below summarize the device integration details of PRU-ICSS XBAR Interrupt router.

Table 10-2. PRU-ICSS XBAR Interrupt router Device Integration

Module Instance	Device Allocation	SoC Interconnect
PRU-ICSS_XBAR_INTRTR0	✓	INFRA0 VBUSP Interconnect

Table 10-3. PRU-ICSS_XBAR_INTRTR0 Clocks

Module Instance	Module Clock in_intr	Source Clock Signal	Source	Default Freq	Description
PRU-ICSS_XBAR_INTRTR0	SYSCLK	SYS_CLK	MSS_RCM	200 MHz	PRU-ICSS_XBAR_INTRTR0 Fncional and Interface clock

Table 10-4. PRU-ICSS_XBAR_INTRTR0 Resets

Module Instance	Module Reset in_intr	Source Reset Signal	Source	Description
PRU-ICSS_XBAR_INTRTR0	RST	SYS_RST	MSS_RCM	PRU-ICSS_XBAR_INTRTR0 Reset

Table 10-5. PRU-ICSS_XBAR_INTRTR0 Output Hardware Requests

Module Instance	Module XBAR Output	Destination XBAR signal	Destination	Type	Description
PRU-ICSS_XBAR_INTRTR0	outl_intr_0	PR1_SLV_INTR_0	PRU-ICSS	Pulse	Selectable Hardware Request 0
	outl_intr_1	PR1_SLV_INTR_1			Selectable Hardware Request 1
	outl_intr_2	PR1_SLV_INTR_2			Selectable Hardware Request 2
	outl_intr_3	PR1_SLV_INTR_3			Selectable Hardware Request 3
	outl_intr_4	PR1_SLV_INTR_4			Selectable Hardware Request 4
	outl_intr_5	PR1_SLV_INTR_5			Selectable Hardware Request 5
	outl_intr_6	PR1_SLV_INTR_6			Selectable Hardware Request 6
	outl_intr_7	PR1_SLV_INTR_7			Selectable Hardware Request 7
	outl_intr_8	PR1_SLV_INTR_8			Selectable Hardware Request 8
	outl_intr_9	PR1_SLV_INTR_9			Selectable Hardware Request 9
	outl_intr_10	PR1_SLV_INTR_10			Selectable Hardware Request 10
	outl_intr_11	PR1_SLV_INTR_11			Selectable Hardware Request 11
	outl_intr_12	PR1_SLV_INTR_12			Selectable Hardware Request 12
	outl_intr_13	PR1_SLV_INTR_13			Selectable Hardware Request 13
	outl_intr_14	PR1_SLV_INTR_14			Selectable Hardware Request 14
	outl_intr_15	PR1_SLV_INTR_15			Selectable Hardware Request 15

Table 10-6. PRU-ICSS_XBAR_INTRTR0 in_intr Hardware Requests

Module Instance	Source Module	Source in_intr signal	XBAR Module in_intr	Type	Description
PRU-ICSS_XBAR_INTRTR0	LIN0	lin0_intr_req0	IN_INTR0	Level	LIN0 Interrupt Request 0
	LIN0	lin0_intr_req1	IN_INTR1		LIN0 Interrupt Request 1
	LIN1	lin1_intr_req0	IN_INTR2		LIN1 Interrupt Request 0
	LIN1	lin1_intr_req1	IN_INTR3		LIN1 Interrupt Request 1
	LIN2	lin2_intr_req0	IN_INTR4		LIN2 Interrupt Request 0
	LIN2	lin2_intr_req1	IN_INTR5		LIN2 Interrupt Request 1
	LIN3	lin3_intr_req0	IN_INTR6		LIN3 Interrupt Request 0
	LIN3	lin3_intr_req1	IN_INTR7		LIN3 Interrupt Request 1
	LIN4	lin4_intr_req0	IN_INTR8		LIN4 Interrupt Request 0
	LIN4	lin4_intr_req1	IN_INTR9		LIN4 Interrupt Request 1
	UART0	uart0_irq	IN_INTR10		UART0 Interrupt
	UART1	uart1_irq	IN_INTR11		UART1 Interrupt
	UART2	uart2_irq	IN_INTR12		UART2 Interrupt
	UART3	uart3_irq	IN_INTR13		UART3 Interrupt
	UART4	uart4_irq	IN_INTR14		UART4 Interrupt
	UART5	uart5_irq	IN_INTR15		UART5 Interrupt
	I2C0	I2C0_IRQ	IN_INTR16		I2C0 Interrupt
	I2C1	I2C1_IRQ	IN_INTR17		I2C1 Interrupt
	I2C2	I2C2_IRQ	IN_INTR18		I2C2 Interrupt
	I2C3	I2C3_IRQ	IN_INTR19		I2C3 Interrupt
	SPI0	SPI0_intr	IN_INTR20		SPI0 Interrupt
	SPI1	SPI1_intr	IN_INTR21		SPI1 Interrupt
	SPI2	SPI2_intr	IN_INTR22		SPI2 Interrupt
	SPI3	SPI3_intr	IN_INTR23		SPI3 Interrupt
	SPI4	SPI4_intr	IN_INTR24		SPI4 Interrupt
	QSPI	qSPI_intr	IN_INTR25		QSPI Interrupt
	SOC_EDMA0	TPCC_intg	IN_INTR26		TPCC Global Interrupt
	SOC_EDMA0	TPCC_int0	IN_INTR27		TPCC Region0 Interrupt
	SOC_EDMA0	TPCC_int1	IN_INTR28		TPCC Region1 Interrupt
	SOC_EDMA0	TPCC_int2	IN_INTR29		TPCC Region2 Interrupt
	SOC_EDMA0	TPCC_int3	IN_INTR30		TPCC Region3 Interrupt
	SOC_EDMA0	TPCC_int4	IN_INTR31		TPCC Region4 Interrupt
	SOC_EDMA0	TPCC_int5	IN_INTR32		TPCC Region5 Interrupt
	SOC_EDMA0	TPCC_int6	IN_INTR33		TPCC Region6 Interrupt
	SOC_EDMA0	TPCC_int7	IN_INTR34		TPCC Region7 Interrupt
	SOC_EDMA0	TPCC_errint	IN_INTR35		TPCC Error Interrupt
	SOC_EDMA0	tpcc_mpint	IN_INTR36		TPCC Memory Protection Violation Interrupt
	SOC_EDMA0	tptc_erint0	IN_INTR37		TPCC Interrupt
	SOC_EDMA0	tptc_erint1	IN_INTR38		TPCC Interrupt
	MCAN0	mcanss0_ext_ts_rollover_lv_l_int	IN_INTR39		MCAN0 External TimeSync Rollover Interrupt
	MCAN0	mcanss0_mcan_lv_l_int_0	IN_INTR40		MCAN0 Interrupt 0
	MCAN0	mcanss0_mcan_lv_l_int_1	IN_INTR41		MCAN0 Interrupt 1
	MCAN1	mcanss1_ext_ts_rollover_lv_l_int	IN_INTR42		MCAN1 External TimeSync Rollover Interrupt
MCAN1	mcanss1_mcan_lv_l_int_0	IN_INTR43	MCAN1 Interrupt 0		
MCAN1	mcanss1_mcan_lv_l_int_1	IN_INTR44	MCAN1 Interrupt 1		
MCAN2	mcanss2_ext_ts_rollover_lv_l_int	IN_INTR45	MCAN2 External TimeSync Rollover Interrupt		

10.3.2.2 EDMA XBAR INTRTR0

There is 1x EDMA XBAR Interrupt Router module integrated in the device. The diagram below provides a visual representation of the device integration details for EDMA XBAR Interrupt Router.

ADVANCE INFORMATION

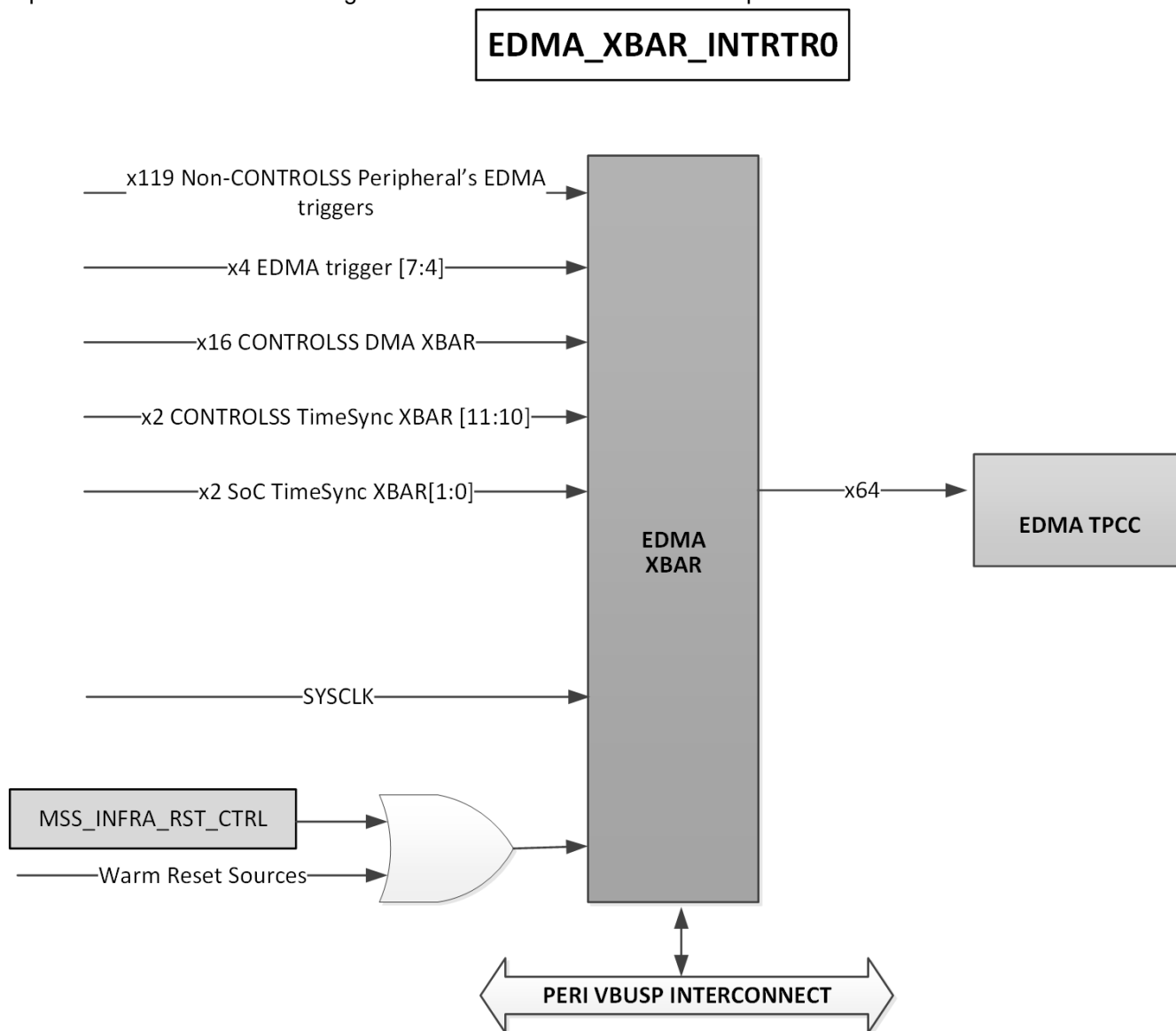

Figure 10-3. EDMA XBAR Interrupt Router Integration Diagram

The tables below summarize the device integration details of EDMA XBAR Interrupt router.

Table 10-7. EDMA XBAR Interrupt router Device Integration

Module Instance	Device Allocation	SoC Interconnect
EDMA_XBAR_INTRTR0	✓	INFRA0 VBUSP Interconnect

Table 10-8. EDMA_XBAR_INTRTR0 Clocks

Module Instance	Module Clock in_intr	Source Clock Signal	Source	Default Freq	Description
EDMA_XBAR_INTRTR0	SYCLK	SYS_CLK	MSS_RCM	200 MHz	EDMA_XBAR_INTRTR0 Functional and Interface clock

Table 10-9. EDMA_XBAR_INTRTR0 Resets

Module Instance	Module Reset in_intr	Source Reset Signal	Source	Description
EDMA_XBAR_INTRTR0	RST	SYS_RST	MSS_RCM	EDMA_XBAR_INTRTR0 Reset

Table 10-10. EDMA_XBAR_INTRTR0 Output Hardware Requests

Module Instance	Module XBAR Output	Destination XBAR signal	Destination	Description	Type
EDMA_XBAR_INTRTR0	outl_intr_0	EDMA_Trigger_XBAROut_0	TPCC	Selectable Hardware Request 0	Pulse
	outl_intr_1	EDMA_Trigger_XBAROut_1		Selectable Hardware Request 1	
	outl_intr_2	EDMA_Trigger_XBAROut_2		Selectable Hardware Request 2	
	outl_intr_3	EDMA_Trigger_XBAROut_3		Selectable Hardware Request 3	
	outl_intr_4	EDMA_Trigger_XBAROut_4		Selectable Hardware Request 4	
	outl_intr_5	EDMA_Trigger_XBAROut_5		Selectable Hardware Request 5	
	outl_intr_6	EDMA_Trigger_XBAROut_6		Selectable Hardware Request 6	
	outl_intr_7	EDMA_Trigger_XBAROut_7		Selectable Hardware Request 7	
	outl_intr_8	EDMA_Trigger_XBAROut_8		Selectable Hardware Request 8	
	outl_intr_9	EDMA_Trigger_XBAROut_9		Selectable Hardware Request 9	
	outl_intr_10	EDMA_Trigger_XBAROut_10		Selectable Hardware Request 10	
	outl_intr_11	EDMA_Trigger_XBAROut_11		Selectable Hardware Request 11	
	outl_intr_12	EDMA_Trigger_XBAROut_12		Selectable Hardware Request 12	
	outl_intr_13	EDMA_Trigger_XBAROut_13		Selectable Hardware Request 13	
	outl_intr_14	EDMA_Trigger_XBAROut_14		Selectable Hardware Request 14	
	outl_intr_15	EDMA_Trigger_XBAROut_15		Selectable Hardware Request 15	
	outl_intr_16	EDMA_Trigger_XBAROut_16		Selectable Hardware Request 16	
	outl_intr_17	EDMA_Trigger_XBAROut_17		Selectable Hardware Request 17	
	outl_intr_18	EDMA_Trigger_XBAROut_18		Selectable Hardware Request 18	
	outl_intr_19	EDMA_Trigger_XBAROut_19		Selectable Hardware Request 19	
	outl_intr_20	EDMA_Trigger_XBAROut_20		Selectable Hardware Request 20	
	outl_intr_21	EDMA_Trigger_XBAROut_21		Selectable Hardware Request 21	
	outl_intr_22	EDMA_Trigger_XBAROut_22		Selectable Hardware Request 22	
	outl_intr_23	EDMA_Trigger_XBAROut_23		Selectable Hardware Request 23	
	outl_intr_24	EDMA_Trigger_XBAROut_24		Selectable Hardware Request 24	
	outl_intr_25	EDMA_Trigger_XBAROut_25		Selectable Hardware Request 25	
	outl_intr_26	EDMA_Trigger_XBAROut_26		Selectable Hardware Request 26	
	outl_intr_27	EDMA_Trigger_XBAROut_27		Selectable Hardware Request 27	
	outl_intr_28	EDMA_Trigger_XBAROut_28		Selectable Hardware Request 28	
	outl_intr_29	EDMA_Trigger_XBAROut_29		Selectable Hardware Request 29	
	outl_intr_30	EDMA_Trigger_XBAROut_30		Selectable Hardware Request 30	
	outl_intr_31	EDMA_Trigger_XBAROut_31		Selectable Hardware Request 31	
	outl_intr_32	EDMA_Trigger_XBAROut_32		Selectable Hardware Request 32	
	outl_intr_33	EDMA_Trigger_XBAROut_33		Selectable Hardware Request 33	
	outl_intr_34	EDMA_Trigger_XBAROut_34		Selectable Hardware Request 34	
	outl_intr_35	EDMA_Trigger_XBAROut_35		Selectable Hardware Request 35	
	outl_intr_36	EDMA_Trigger_XBAROut_36		Selectable Hardware Request 36	
	outl_intr_37	EDMA_Trigger_XBAROut_37		Selectable Hardware Request 37	
	outl_intr_38	EDMA_Trigger_XBAROut_38		Selectable Hardware Request 38	
	outl_intr_39	EDMA_Trigger_XBAROut_39		Selectable Hardware Request 39	
	outl_intr_40	EDMA_Trigger_XBAROut_40		Selectable Hardware Request 40	
	outl_intr_41	EDMA_Trigger_XBAROut_41		Selectable Hardware Request 41	
	outl_intr_42	EDMA_Trigger_XBAROut_42		Selectable Hardware Request 42	
	outl_intr_43	EDMA_Trigger_XBAROut_43		Selectable Hardware Request 43	
	outl_intr_44	EDMA_Trigger_XBAROut_44		Selectable Hardware Request 44	
outl_intr_45	EDMA_Trigger_XBAROut_45	Selectable Hardware Request 45			

ADVANCE INFORMATION

Table 10-11. EDMA_XBAR_INTRTR0 in_intr Hardware Requests

Module Instance	Source Module	Source in_intr signal	XBAR Module in_intr	Description	Type
EDMA_XBAR_INTRTR0	LIN0	lin0_RXDMA	IN_INTR0	LIN0 RX DMA Request	Pulse
	LIN0	lin0_TXDMA	IN_INTR1	LIN0 TX DMA Request	Pulse
	LIN1	lin1_RXDMA	IN_INTR2	LIN1 RX DMA Request	Pulse
	LIN1	lin0_TXDMA	IN_INTR3	LIN1 TX DMA Request	Pulse
	LIN2	lin2_RXDMA	IN_INTR4	LIN2 RX DMA Request	Pulse
	LIN2	lin2_TXDMA	IN_INTR5	LIN2 TX DMA Request	Pulse
	LIN3	lin3_RXDMA	IN_INTR6	LIN3 RX DMA Request	Pulse
	LIN3	lin3_TXDMA	IN_INTR7	LIN3 TX DMA Request	Pulse
	LIN4	lin4_RXDMA	IN_INTR8	LIN4 RX DMA Request	Pulse
	LIN4	lin4_TXDMA	IN_INTR9	LIN4 TX DMA Request	Pulse
	I2C0	I2C0_TX	IN_INTR10	I2C0 RX DMA Request	Pulse
	I2C0	I2C0_RX	IN_INTR11	I2C0 TX DMA Request	Pulse
	I2C1	I2C1_TX	IN_INTR12	I2C1 RX DMA Request	Pulse
	I2C1	I2C1_RX	IN_INTR13	I2C1 TX DMA Request	Pulse
	I2C2	I2C2_TX	IN_INTR14	I2C2 RX DMA Request	Pulse
	I2C2	I2C2_RX	IN_INTR15	I2C2 TX DMA Request	Pulse
	I2C3	I2C3_TX	IN_INTR16	I2C3 RX DMA Request	Pulse
	I2C3	I2C3_RX	IN_INTR17	I2C3 TX DMA Request	Pulse
	SPI0	SPI0_dma_Read_req0	IN_INTR18	SPI0 DMA Read Request 0	Pulse
	SPI0	SPI0_dma_Read_req1	IN_INTR19	SPI0 DMA Read Request 1	Pulse
	SPI0	SPI0_dma_Read_req2	IN_INTR20	SPI0 DMA Read Request 2	Pulse
	SPI0	SPI0_dma_Read_req3	IN_INTR21	SPI0 DMA Read Request 3	Pulse
	SPI0	SPI0_dma_Write_req0	IN_INTR22	SPI0 DMA Write Request 0	Pulse
	SPI0	SPI0_dma_Write_req1	IN_INTR23	SPI0 DMA Write Request 1	Pulse
	SPI0	SPI0_dma_Write_req2	IN_INTR24	SPI0 DMA Write Request 2	Pulse
	SPI0	SPI0_dma_Write_req3	IN_INTR25	SPI0 DMA Write Request 3	Pulse
	SPI1	SPI1_dma_Read_req0	IN_INTR26	SPI1 DMA Read Request 0	Pulse
	SPI1	SPI1_dma_Read_req1	IN_INTR27	SPI1 DMA Read Request 1	Pulse
	SPI1	SPI1_dma_Read_req2	IN_INTR28	SPI1 DMA Read Request 2	Pulse
	SPI1	SPI1_dma_Read_req3	IN_INTR29	SPI1 DMA Read Request 3	Pulse
	SPI1	SPI1_dma_Write_req0	IN_INTR30	SPI1 DMA Write Request 0	Pulse
	SPI1	SPI1_dma_Write_req1	IN_INTR31	SPI1 DMA Write Request 1	Pulse
	SPI1	SPI1_dma_Write_req2	IN_INTR32	SPI1 DMA Write Request 2	Pulse
	SPI1	SPI1_dma_Write_req3	IN_INTR33	SPI1 DMA Write Request 3	Pulse
	SPI2	SPI2_dma_Read_req0	IN_INTR34	SPI2 DMA Read Request 0	Pulse
	SPI2	SPI2_dma_Read_req1	IN_INTR35	SPI2 DMA Read Request 1	Pulse
	SPI2	SPI2_dma_Read_req2	IN_INTR36	SPI2 DMA Read Request 2	Pulse
	SPI2	SPI2_dma_Read_req3	IN_INTR37	SPI2 DMA Read Request 3	Pulse
	SPI2	SPI2_dma_Write_req0	IN_INTR38	SPI2 DMA Write Request 0	Pulse
	SPI2	SPI2_dma_Write_req1	IN_INTR39	SPI2 DMA Write Request 1	Pulse
	SPI2	SPI2_dma_Write_req2	IN_INTR40	SPI2 DMA Write Request 2	Pulse
	SPI2	SPI2_dma_Write_req3	IN_INTR41	SPI2 DMA Write Request 3	Pulse
	SPI3	SPI3_dma_Read_req0	IN_INTR42	SPI3 DMA Read Request 0	Pulse
	SPI3	SPI3_dma_Read_req1	IN_INTR43	SPI3 DMA Read Request 1	Pulse

Table 10-11. EDMA_XBAR_INTRTR0 in_intr Hardware Requests (continued)

Module Instance	Source Module	Source in_intr signal	XBAR Module in_intr	Description	Type
	SPI3	SPI3_dma_Read_req2	IN_INTR44	SPI3 DMA Read Request 2	Pulse
	SPI3	SPI3_dma_Read_req3	IN_INTR45	SPI3 DMA Read Request 3	Pulse
	SPI3	SPI3_dma_Write_req0	IN_INTR46	SPI3 DMA Write Request 0	Pulse
	SPI3	SPI3_dma_Write_req1	IN_INTR47	SPI3 DMA Write Request 1	Pulse
	SPI3	SPI3_dma_Write_req2	IN_INTR48	SPI3 DMA Write Request 2	Pulse
	SPI3	SPI3_dma_Write_req3	IN_INTR49	SPI3 DMA Write Request 3	Pulse
	SPI4	SPI4_dma_Read_req0	IN_INTR50	SPI4 DMA Read Request 0	Pulse
	SPI4	SPI4_dma_Read_req1	IN_INTR51	SPI4 DMA Read Request 1	Pulse
	SPI4	SPI4_dma_Read_req2	IN_INTR52	SPI4 DMA Read Request 2	Pulse
	SPI4	SPI4_dma_Read_req3	IN_INTR53	SPI4 DMA Read Request 3	Pulse
	SPI4	SPI4_dma_Write_req0	IN_INTR54	SPI4 DMA Write Request 0	Pulse
	SPI4	SPI4_dma_Write_req1	IN_INTR55	SPI4 DMA Write Request 1	Pulse
	SPI4	SPI4_dma_Write_req2	IN_INTR56	SPI4 DMA Write Request 2	Pulse
	SPI4	SPI4_dma_Write_req3	IN_INTR57	SPI4 DMA Write Request 3	Pulse
	RTI0	RTI_DMA_0	IN_INTR58	RTI0 DMA Request 0	Pulse
	RTI0	RTI_DMA_1	IN_INTR59	RTI0 DMA Request 1	Pulse
	RTI0	RTI_DMA_2	IN_INTR60	RTI0 DMA Request 2	Pulse
	RTI0	RTI_DMA_3	IN_INTR61	RTI0 DMA Request 3	Pulse
	RTI1	RTI_DMA_0	IN_INTR62	RTI1 DMA Request 0	Pulse
	RTI1	RTI_DMA_1	IN_INTR63	RTI1 DMA Request 1	Pulse
	RTI1	RTI_DMA_2	IN_INTR64	RTI1 DMA Request 2	Pulse
	RTI1	RTI_DMA_3	IN_INTR65	RTI1 DMA Request 3	Pulse
	RTI2	RTI_DMA_0	IN_INTR66	RTI2 DMA Request 0	Pulse
	RTI2	RTI_DMA_1	IN_INTR67	RTI2 DMA Request 1	Pulse
	RTI2	RTI_DMA_2	IN_INTR68	RTI2 DMA Request 2	Pulse
	RTI2	RTI_DMA_3	IN_INTR69	RTI2 DMA Request 3	Pulse
	RTI3	RTI_DMA_0	IN_INTR70	RTI3 DMA Request 0	Pulse
	RTI3	RTI_DMA_1	IN_INTR71	RTI3 DMA Request 1	Pulse
	RTI3	RTI_DMA_2	IN_INTR72	RTI3 DMA Request 2	Pulse
	RTI3	RTI_DMA_3	IN_INTR73	RTI3 DMA Request 3	Pulse
	MCAN0	mcanss0_tx_dma_0	IN_INTR74	MCAN0 TX DMA Request 0	Pulse
	MCAN0	mcanss0_tx_dma_1	IN_INTR75	MCAN0 TX DMA Request 1	Pulse
	MCAN0	mcanss0_tx_dma_2	IN_INTR76	MCAN0 TX DMA Request 2	Pulse
	MCAN0	mcanss0_tx_dma_3	IN_INTR77	MCAN0 TX DMA Request 3	Pulse
	MCAN1	mcanss1_tx_dma_0	IN_INTR78	MCAN1 TX DMA Request 0	Pulse
	MCAN1	mcanss1_tx_dma_1	IN_INTR79	MCAN1 TX DMA Request 1	Pulse
	MCAN1	mcanss1_tx_dma_2	IN_INTR80	MCAN1 TX DMA Request 2	Pulse
	MCAN1	mcanss1_tx_dma_3	IN_INTR81	MCAN1 TX DMA Request 3	Pulse
	MCAN2	mcanss2_tx_dma_0	IN_INTR82	MCAN2 TX DMA Request 0	Pulse
	MCAN2	mcanss2_tx_dma_1	IN_INTR83	MCAN2 TX DMA Request 1	Pulse
	MCAN2	mcanss2_tx_dma_2	IN_INTR84	MCAN2 TX DMA Request 2	Pulse
	MCAN2	mcanss2_tx_dma_3	IN_INTR85	MCAN2 TX DMA Request 3	Pulse
	MCAN3	mcanss3_tx_dma_0	IN_INTR86	MCAN3 TX DMA Request 0	Pulse
	MCAN3	mcanss3_tx_dma_1	IN_INTR87	MCAN3 TX DMA Request 1	Pulse

Table 10-11. EDMA_XBAR_INTRTR0 in_intr Hardware Requests (continued)

Module Instance	Source Module	Source in_intr signal	XBAR Module in_intr	Description	Type
	MCAN3	mcanss3_tx_dma_2	IN_INTR88	MCAN3 TX DMA Request 2	Pulse
	MCAN3	mcanss3_tx_dma_3	IN_INTR89	MCAN3 TX DMA Request 3	Pulse
	UART0	usart0_dma_0	IN_INTR90	UART0 DMA Request 0	Pulse
	UART0	usart0_dma_1	IN_INTR91	UART0 DMA Request 1	Pulse
	UART1	usart1_dma_0	IN_INTR92	UART1 DMA Request 0	Pulse
	UART1	usart1_dma_1	IN_INTR93	UART1 DMA Request 1	Pulse
	UART2	usart2_dma_0	IN_INTR94	UART2 DMA Request 0	Pulse
	UART2	usart2_dma_1	IN_INTR95	UART2 DMA Request 1	Pulse
	UART3	usart0_dma_0	IN_INTR96	UART3 DMA Request 0	Pulse
	UART3	usart3_dma_1	IN_INTR97	UART3 DMA Request 1	Pulse
	UART4	usart4_dma_0	IN_INTR98	UART4 DMA Request 0	Pulse
	UART4	usart4_dma_1	IN_INTR99	UART4 DMA Request 1	Pulse
	UART5	usart5_dma_0	IN_INTR100	UART5 DMA Request 0	Pulse
	UART5	usart5_dma_1	IN_INTR101	UART5 DMA Request 1	Pulse
	MCRC	mrcr_DMA_Event_0	IN_INTR102	MCRC DMA Event 0	Pulse
	MCRC	mrcr_DMA_Event_1	IN_INTR103	MCRC DMA Event 1	Pulse
	MCRC	mrcr_DMA_Event_2	IN_INTR104	MCRC DMA Event 2	Pulse
	MCRC	mrcr_DMA_Event_3	IN_INTR105	MCRC DMA Event 3	Pulse
	QSPI	qSPI_intr	IN_INTR106	QSPI Interrupt	Pulse
	GPIO_XBAR	GPIO_xbarout_4	IN_INTR107	GPIO XBAR Out 4	Pulse
	GPIO_XBAR	GPIO_xbarout_5	IN_INTR108	GPIO XBAR Out 5	Pulse
	GPIO_XBAR	GPIO_xbarout_6	IN_INTR109	GPIO XBAR Out 6	Pulse
	GPIO_XBAR	GPIO_xbarout_7	IN_INTR110	GPIO XBAR Out 7	Pulse
	SOC_TimeSync_XBAR	Sync_Xbarout_0	IN_INTR111	SOC TimeSync XBAR Out 0	Pulse
	SOC_TimeSync_XBAR	Sync_Xbarout_1	IN_INTR112	SOC TimeSync XBAR Out 1	Pulse
	CONTROLSS_TimeSync_XBAR	C2k_timesync_xbar.out10	IN_INTR113	CONTROLSS TimeSync XBAR Out 0	Pulse
	CONTROLSS_TimeSync_XBAR	C2k_timesync_xbar.out11	IN_INTR114	CONTROLSS TimeSync XBAR Out 1	Pulse
	CONTROLSS_DMA_XBAR	CCSS_DMA_0	IN_INTR115	CONTROLSS EDMA_XBAR Out 0	Pulse
	CONTROLSS_DMA_XBAR	CCSS_DMA_1	IN_INTR116	CONTROLSS EDMA_XBAR Out 1	Pulse
	CONTROLSS_DMA_XBAR	CCSS_DMA_2	IN_INTR117	CONTROLSS EDMA_XBAR Out 2	Pulse
	CONTROLSS_DMA_XBAR	CCSS_DMA_3	IN_INTR118	CONTROLSS EDMA_XBAR Out 3	Pulse
	CONTROLSS_DMA_XBAR	CCSS_DMA_4	IN_INTR119	CONTROLSS EDMA_XBAR Out 4	Pulse
	CONTROLSS_DMA_XBAR	CCSS_DMA_5	IN_INTR120	CONTROLSS EDMA_XBAR Out 5	Pulse
	CONTROLSS_DMA_XBAR	CCSS_DMA_6	IN_INTR121	CONTROLSS EDMA_XBAR Out 6	Pulse
	CONTROLSS_DMA_XBAR	CCSS_DMA_7	IN_INTR122	CONTROLSS EDMA_XBAR Out 7	Pulse
	CONTROLSS_DMA_XBAR	CCSS_DMA_8	IN_INTR123	CONTROLSS EDMA_XBAR Out 8	Pulse

Table 10-11. EDMA_XBAR_INTRTR0 in_intr Hardware Requests (continued)

Module Instance	Source Module	Source in_intr signal	XBAR Module in_intr	Description	Type
	CONTROLSS_DMA_XBAR	CCSS_DMA_9	IN_INTR124	CONTROLSS EDMA_XBAR Out 9	Pulse
	CONTROLSS_DMA_XBAR	CCSS_DMA_10	IN_INTR125	CONTROLSS EDMA_XBAR Out 10	Pulse
	CONTROLSS_DMA_XBAR	CCSS_DMA_11	IN_INTR126	CONTROLSS EDMA_XBAR Out 11	Pulse
	CONTROLSS_DMA_XBAR	CCSS_DMA_12	IN_INTR127	CONTROLSS EDMA_XBAR Out 12	Pulse
	CONTROLSS_DMA_XBAR	CCSS_DMA_13	IN_INTR128	CONTROLSS EDMA_XBAR Out 13	Pulse
	CONTROLSS_DMA_XBAR	CCSS_DMA_14	IN_INTR129	CONTROLSS EDMA_XBAR Out 14	Pulse
	CONTROLSS_DMA_XBAR	CCSS_DMA_15	IN_INTR130	CONTROLSS EDMA_XBAR Out 15	Pulse
	MMCSD	mmc_DMA_RD	IN_INTR131	MMCSD DMA Read Request	Pulse
	MMCSD	mmc_DMA_WR	IN_INTR132	MMCSD DMA Write Request	Pulse
	DTHE	DTHE_SHA_DMA_REQ0	IN_INTR133	DTHE SHA DMA Request 0	Pulse
	DTHE	DTHE_SHA_DMA_REQ1	IN_INTR134	DTHE SHA DMA Request 1	Pulse
	DTHE	DTHE_SHA_DMA_REQ2	IN_INTR135	DTHE SHA DMA Request 2	Pulse
	DTHE	DTHE_SHA_DMA_REQ3	IN_INTR136	DTHE SHA DMA Request 3	Pulse
	DTHE	DTHE_SHA_DMA_REQ4	IN_INTR137	DTHE SHA DMA Request 4	Pulse
	DTHE	DTHE_SHA_DMA_REQ5	IN_INTR138	DTHE SHA DMA Request 5	Pulse
	DTHE	DTHE_AES_DMA_REQ0	IN_INTR139	DTHE AES DMA Request 0	Pulse
	DTHE	DTHE_AES_DMA_REQ1	IN_INTR140	DTHE AES DMA Request 1	Pulse
	DTHE	DTHE_AES_DMA_REQ2	IN_INTR141	DTHE AES DMA Request 2	Pulse
	DTHE	DTHE_AES_DMA_REQ3	IN_INTR142	DTHE AES DMA Request 3	Pulse
	DTHE	DTHE_AES_DMA_REQ4	IN_INTR143	DTHE AES DMA Request 4	Pulse
	DTHE	DTHE_AES_DMA_REQ5	IN_INTR144	DTHE AES DMA Request 5	Pulse
	DTHE	DTHE_AES_DMA_REQ6	IN_INTR145	DTHE AES DMA Request 6	Pulse
	DTHE	DTHE_AES_DMA_REQ7	IN_INTR146	DTHE AES DMA Request 7	Pulse
	MCAN0	mcanss0_fe_0	IN_INTR147	MCAN0 Request 0	Pulse
	MCAN0	mcanss0_fe_1	IN_INTR148	MCAN0 Request 1	Pulse
	MCAN0	mcanss0_fe_2	IN_INTR149	MCAN0 Request 2	Pulse
	MCAN0	mcanss0_fe_3	IN_INTR150	MCAN0 Request 3	Pulse
	MCAN0	mcanss0_fe_4	IN_INTR151	MCAN0 Request 4	Pulse
	MCAN0	mcanss0_fe_5	IN_INTR152	MCAN0 Request 5	Pulse
	MCAN0	mcanss0_fe_6	IN_INTR153	MCAN0 Request 6	Pulse
	MCAN1	mcanss1_fe_0	IN_INTR154	MCAN1 Request 0	Pulse
	MCAN1	mcanss1_fe_1	IN_INTR155	MCAN1 Request 1	Pulse
	MCAN1	mcanss1_fe_2	IN_INTR156	MCAN1 Request 2	Pulse
	MCAN1	mcanss1_fe_3	IN_INTR157	MCAN1 Request 3	Pulse
	MCAN1	mcanss1_fe_4	IN_INTR158	MCAN1 Request 4	Pulse
	MCAN1	mcanss1_fe_5	IN_INTR159	MCAN1 Request 5	Pulse
	MCAN1	mcanss1_fe_6	IN_INTR160	MCAN1 Request 6	Pulse
	MCAN2	mcanss2_fe_0	IN_INTR161	MCAN2 Request 0	Pulse
	MCAN2	mcanss2_fe_1	IN_INTR162	MCAN2 Request 1	Pulse
	MCAN2	mcanss2_fe_2	IN_INTR163	MCAN2 Request 2	Pulse

Table 10-11. EDMA_XBAR_INTRTR0 in_intr Hardware Requests (continued)

Module Instance	Source Module	Source in_intr signal	XBAR Module in_intr	Description	Type
	MCAN2	mcanss2_fe_3	IN_INTR164	MCAN2 Request 3	Pulse
	MCAN2	mcanss2_fe_4	IN_INTR165	MCAN2 Request 4	Pulse
	MCAN2	mcanss2_fe_5	IN_INTR166	MCAN2 Request 5	Pulse
	MCAN2	mcanss2_fe_6	IN_INTR167	MCAN2 Request 6	Pulse
	MCAN3	mcanss3_fe_0	IN_INTR168	MCAN3 Request 0	Pulse
	MCAN3	mcanss3_fe_1	IN_INTR169	MCAN3 Request 1	Pulse
	MCAN3	mcanss3_fe_2	IN_INTR170	MCAN3 Request 2	Pulse
	MCAN3	mcanss3_fe_3	IN_INTR171	MCAN3 Request 3	Pulse
	MCAN3	mcanss3_fe_4	IN_INTR172	MCAN3 Request 4	Pulse
	MCAN3	mcanss3_fe_5	IN_INTR173	MCAN3 Request 5	Pulse
	MCAN3	mcanss3_fe_6	IN_INTR174	MCAN3 Request 6	Pulse
	GPMC	gpmc_sdmareq	IN_INTR175	GPMC SDMA Request	Pulse

10.3.2.3 GPIO XBAR INTRTR0

There is 1x GPIO XBAR Interrupt Router module integrated in the device. The diagram below provides a visual representation of the device integration details for GPIO XBAR Interrupt router.

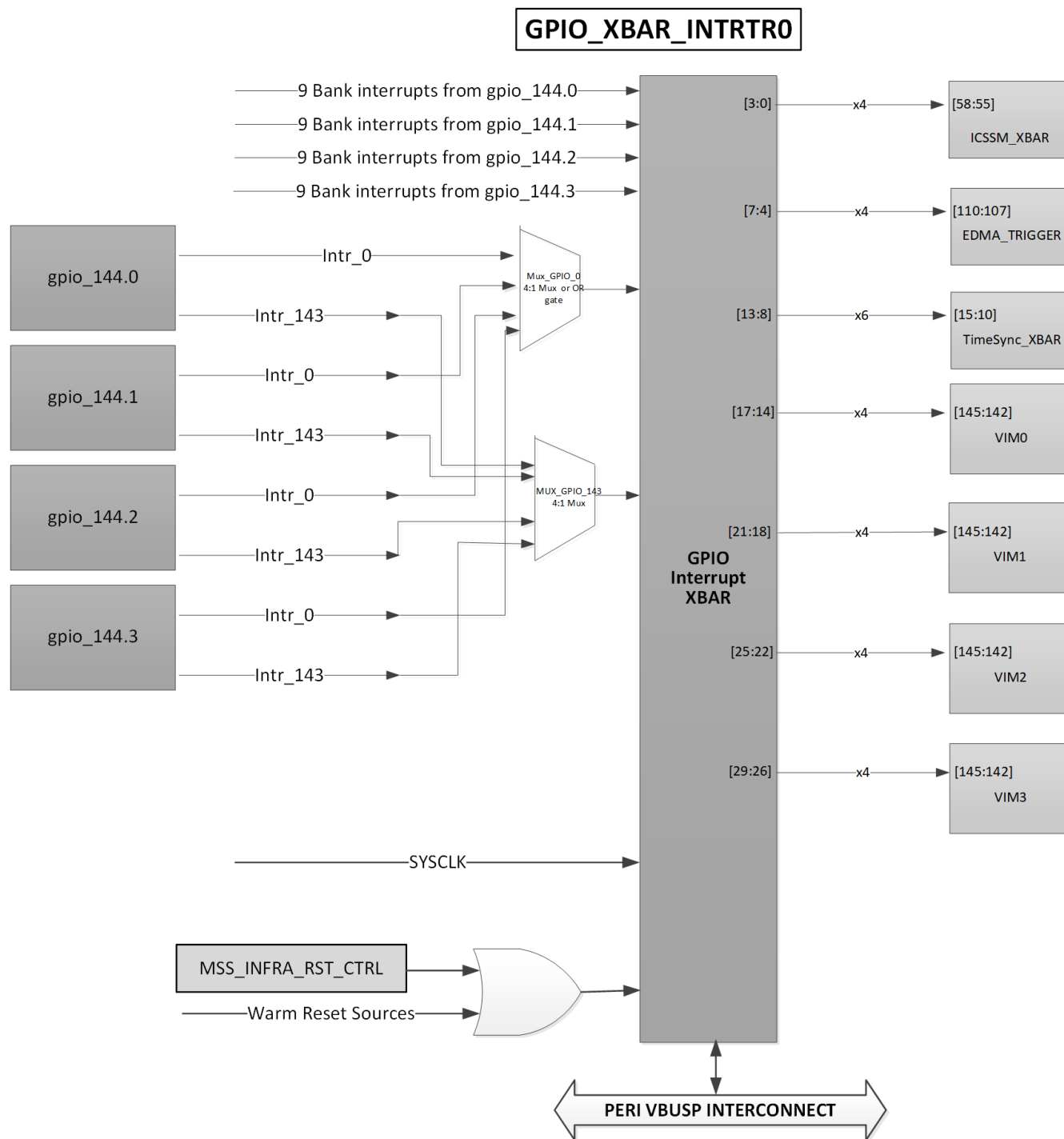

Figure 10-4. GPIO XBAR Interrupt Router Integration Diagram

The tables below summarize the device integration details of GPIO XBAR Interrupt router.

Table 10-12. GPIO XBAR Interrupt router Device Integration

Module Instance	Device Allocation	SoC Interconnect
GPIO_XBAR_INTRTR0	✓	INFRA0 VBUSP Interconnect

Table 10-13. GPIO_XBAR_INTRTR0 Clocks

Module Instance	Module Clock in_intr	Source Clock Signal	Source	Default Freq	Description
GPIO_XBAR_INTRTR0	SYSCLK	SYS_CLK	MSS_RCM	200 MHz	GPIO_XBAR_INTRTR0 Functional and Interface clock

Table 10-14. GPIO_XBAR_INTRTR0 Resets

Module Instance	Module Reset in_intr	Source Reset Signal	Source	Description
GPIO_XBAR_INTRTR0	RST	SYS_RST	MSS_RCM	GPIO_XBAR_INTRTR0 Reset

Table 10-15. GPIO_XBAR_INTRTR0 Output Hardware Requests

Module Instance	Module XBAR Output	Destination XBAR signal	Destination	Description	Type
GPIO_XBAR_INTRTR0	outl_intr_0	GPIO_XBAR_ICSSM_out_0	ICSSM_XBAR	Selectable Hardware Request0	Pulse
	outl_intr_1	GPIO_XBAR_ICSSM_out_1	ICSSM_XBAR	Selectable Hardware Request1	
	outl_intr_2	GPIO_XBAR_ICSSM_out_2	ICSSM_XBAR	Selectable Hardware Request2	
	outl_intr_3	GPIO_XBAR_ICSSM_out_3	ICSSM_XBAR	Selectable Hardware Request3	
	outl_intr_4	GPIO_XBAR_EDMA_out_0	EDMA_XBAR	Selectable Hardware Request4	
	outl_intr_5	GPIO_XBAR_EDMA_out_1	EDMA_XBAR	Selectable Hardware Request5	
	outl_intr_6	GPIO_XBAR_EDMA_out_2	EDMA_XBAR	Selectable Hardware Request6	
	outl_intr_7	GPIO_XBAR_EDMA_out_3	EDMA_XBAR	Selectable Hardware Request7	
	outl_intr_8	GPIO_XBAR_TimeSync_out_0	TimeSync_XBAR	Selectable Hardware Request8	
	outl_intr_9	GPIO_XBAR_TimeSync_out_1	TimeSync_XBAR	Selectable Hardware Request9	
	outl_intr_10	GPIO_XBAR_TimeSync_out_2	TimeSync_XBAR	Selectable Hardware Request10	
	outl_intr_11	GPIO_XBAR_TimeSync_out_3	TimeSync_XBAR	Selectable Hardware Request11	
	outl_intr_12	GPIO_XBAR_TimeSync_out_4	TimeSync_XBAR	Selectable Hardware Request12	
	outl_intr_13	GPIO_XBAR_TimeSync_out_5	TimeSync_XBAR	Selectable Hardware Request13	
	outl_intr_14	GPIO_XBAR_VIM0_out_0	VIM_0	Selectable Hardware Request14	
	outl_intr_15	GPIO_XBAR_VIM0_out_1	VIM_0	Selectable Hardware Request15	
	outl_intr_16	GPIO_XBAR_VIM0_out_2	VIM_0	Selectable Hardware Request16	
	outl_intr_17	GPIO_XBAR_VIM0_out_3	VIM_0	Selectable Hardware Request17	
	outl_intr_18	GPIO_XBAR_VIM1_out_0	VIM_1	Selectable Hardware Request18	
	outl_intr_19	GPIO_XBAR_VIM1_out_1	VIM_1	Selectable Hardware Request19	
	outl_intr_20	GPIO_XBAR_VIM1_out_2	VIM_1	Selectable Hardware Request20	
	outl_intr_21	GPIO_XBAR_VIM1_out_3	VIM_1	Selectable Hardware Request21	
	outl_intr_22	GPIO_XBAR_VIM2_out_0	VIM_2	Selectable Hardware Request22	
	outl_intr_23	GPIO_XBAR_VIM2_out_1	VIM_2	Selectable Hardware Request23	
	outl_intr_24	GPIO_XBAR_VIM2_out_2	VIM_2	Selectable Hardware Request24	
	outl_intr_25	GPIO_XBAR_VIM2_out_3	VIM_2	Selectable Hardware Request25	
	outl_intr_26	GPIO_XBAR_VIM3_out_0	VIM_3	Selectable Hardware Request26	
	outl_intr_27	GPIO_XBAR_VIM3_out_1	VIM_3	Selectable Hardware Request27	
	outl_intr_28	GPIO_XBAR_VIM3_out_2	VIM_3	Selectable Hardware Request28	
outl_intr_29	GPIO_XBAR_VIM3_out_3	VIM_3	Selectable Hardware Request29		

ADVANCE INFORMATION

Table 10-16. GPIO_XBAR_INTRTR0 in_intr Hardware Requests

Module Instance	Source Module	Source in_intr signal	XBAR Module in_intr	Description	Type
GPIO_XBAR_INTRTR0	GPIO_0	mux_GPIO_0	in_intr_0	gpio_144x.intr_0 in_intr	Pulse
	GPIO_1	mux_GPIO_1	in_intr_1	gpio_144x.intr_1 in_intr	
	GPIO_2	mux_GPIO_2	in_intr_2	gpio_144x.intr_2 in_intr	
	GPIO_3	mux_GPIO_3	in_intr_3	gpio_144x.intr_3 in_intr	
	GPIO_4	mux_GPIO_4	in_intr_4	gpio_144x.intr_4 in_intr	
	GPIO_5	mux_GPIO_5	in_intr_5	gpio_144x.intr_5 in_intr	
	GPIO_6	mux_GPIO_6	in_intr_6	gpio_144x.intr_6 in_intr	
	GPIO_7	mux_GPIO_7	in_intr_7	gpio_144x.intr_7 in_intr	
	GPIO_8	mux_GPIO_8	in_intr_8	gpio_144x.intr_8 in_intr	
	GPIO_9	mux_GPIO_9	in_intr_9	gpio_144x.intr_9 in_intr	
	GPIO_10	mux_GPIO_10	in_intr_10	gpio_144x.intr_10 in_intr	
	GPIO_11	mux_GPIO_11	in_intr_11	gpio_144x.intr_11 in_intr	
	GPIO_12	mux_GPIO_12	in_intr_12	gpio_144x.intr_12 in_intr	
	GPIO_13	mux_GPIO_13	in_intr_13	gpio_144x.intr_13 in_intr	
	GPIO_14	mux_GPIO_14	in_intr_14	gpio_144x.intr_14 in_intr	
	GPIO_15	mux_GPIO_15	in_intr_15	gpio_144x.intr_15 in_intr	
	GPIO_16	mux_GPIO_16	in_intr_16	gpio_144x.intr_16 in_intr	
	GPIO_17	mux_GPIO_17	in_intr_17	gpio_144x.intr_17 in_intr	
	GPIO_18	mux_GPIO_18	in_intr_18	gpio_144x.intr_18 in_intr	
	GPIO_19	mux_GPIO_19	in_intr_19	gpio_144x.intr_19 in_intr	
	GPIO_20	mux_GPIO_20	in_intr_20	gpio_144x.intr_20 in_intr	
	GPIO_21	mux_GPIO_21	in_intr_21	gpio_144x.intr_21 in_intr	
	GPIO_22	mux_GPIO_22	in_intr_22	gpio_144x.intr_22 in_intr	
	GPIO_23	mux_GPIO_23	in_intr_23	gpio_144x.intr_23 in_intr	
	GPIO_24	mux_GPIO_24	in_intr_24	gpio_144x.intr_24 in_intr	
	GPIO_25	mux_GPIO_25	in_intr_25	gpio_144x.intr_25 in_intr	
	GPIO_26	mux_GPIO_26	in_intr_26	gpio_144x.intr_26 in_intr	
	GPIO_27	mux_GPIO_27	in_intr_27	gpio_144x.intr_27 in_intr	
	GPIO_28	mux_GPIO_28	in_intr_28	gpio_144x.intr_28 in_intr	
	GPIO_29	mux_GPIO_29	in_intr_29	gpio_144x.intr_29 in_intr	
	GPIO_30	mux_GPIO_30	in_intr_30	gpio_144x.intr_30 in_intr	
	GPIO_31	mux_GPIO_31	in_intr_31	gpio_144x.intr_31 in_intr	
	GPIO_32	mux_GPIO_32	in_intr_32	gpio_144x.intr_32 in_intr	
	GPIO_33	mux_GPIO_33	in_intr_33	gpio_144x.intr_33 in_intr	
	GPIO_34	mux_GPIO_34	in_intr_34	gpio_144x.intr_34 in_intr	
	GPIO_35	mux_GPIO_35	in_intr_35	gpio_144x.intr_35 in_intr	
	GPIO_36	mux_GPIO_36	in_intr_36	gpio_144x.intr_36 in_intr	
	GPIO_37	mux_GPIO_37	in_intr_37	gpio_144x.intr_37 in_intr	
	GPIO_38	mux_GPIO_38	in_intr_38	gpio_144x.intr_38 in_intr	
	GPIO_39	mux_GPIO_39	in_intr_39	gpio_144x.intr_38 in_intr	
	GPIO_40	mux_GPIO_40	in_intr_40	gpio_144x.intr_40 in_intr	
	GPIO_41	mux_GPIO_41	in_intr_41	gpio_144x.intr_41 in_intr	
	GPIO_42	mux_GPIO_42	in_intr_42	gpio_144x.intr_42 in_intr	
	GPIO_43	mux_GPIO_43	in_intr_43	gpio_144x.intr_43 in_intr	
	GPIO_44	mux_GPIO_44	in_intr_44	gpio_144x.intr_44 in_intr	
	GPIO_45	mux_GPIO_45	in_intr_45	gpio_144x.intr_45 in_intr	
GPIO_46	mux_GPIO_46	in_intr_46	gpio_144x.intr_46 in_intr		
GPIO_47	mux_GPIO_47	in_intr_47	gpio_144x.intr_47 in_intr		
GPIO_48	mux_GPIO_48	in_intr_48	gpio_144x.intr_48 in_intr		

10.4 Interrupt Sources

10.4.1 R5FSS0_CORE0 Interrupt Map

Table 10-17 shows the mapping of events to the R5FSS0_CORE0.

Both R5FSS0_CORE0 and R5FSS0_CORE1 use the R5FSS0_CORE0 interrupt map when operating in lockstep mode.

Table 10-17. R5FSS0_CORE0 Interrupt Map

Interrupt Input Line	Interrupt ID	Source Interrupt
R5FSS0_CORE0_INTR_IN_0	0	R5FSS0_CORE0_INTR_PRU_ICSSM0_PR1_HOST_INTR_PEND_0
R5FSS0_CORE0_INTR_IN_1	1	R5FSS0_CORE0_INTR_PRU_ICSSM0_PR1_HOST_INTR_PEND_1
R5FSS0_CORE0_INTR_IN_2	2	R5FSS0_CORE0_INTR_PRU_ICSSM0_PR1_HOST_INTR_PEND_2
R5FSS0_CORE0_INTR_IN_3	3	R5FSS0_CORE0_INTR_PRU_ICSSM0_PR1_HOST_INTR_PEND_3
R5FSS0_CORE0_INTR_IN_4	4	R5FSS0_CORE0_INTR_PRU_ICSSM0_PR1_HOST_INTR_PEND_4
R5FSS0_CORE0_INTR_IN_5	5	R5FSS0_CORE0_INTR_PRU_ICSSM0_PR1_HOST_INTR_PEND_5
R5FSS0_CORE0_INTR_IN_6	6	R5FSS0_CORE0_INTR_PRU_ICSSM0_PR1_HOST_INTR_PEND_6
R5FSS0_CORE0_INTR_IN_7	7	R5FSS0_CORE0_INTR_PRU_ICSSM0_PR1_HOST_INTR_PEND_7
R5FSS0_CORE0_INTR_IN_8	8	R5FSS0_CORE0_INTR_PRU_ICSSM0_PR1_RX_SOF_INTR_REQ_0
R5FSS0_CORE0_INTR_IN_9	9	R5FSS0_CORE0_INTR_PRU_ICSSM0_PR1_RX_SOF_INTR_REQ_1
R5FSS0_CORE0_INTR_IN_10	10	R5FSS0_CORE0_INTR_PRU_ICSSM0_PR1_TX_SOF_INTR_REQ_0
R5FSS0_CORE0_INTR_IN_11	11	R5FSS0_CORE0_INTR_PRU_ICSSM0_PR1_TX_SOF_INTR_REQ_1
R5FSS0_CORE0_INTR_IN_12	12	R5FSS0_CORE0_INTR_CPSW0_FH_INTR
R5FSS0_CORE0_INTR_IN_13	13	R5FSS0_CORE0_INTR_CPSW0_TH_INTR
R5FSS0_CORE0_INTR_IN_14	14	R5FSS0_CORE0_INTR_CPSW0_TH_THRESH_INTR
R5FSS0_CORE0_INTR_IN_15	15	R5FSS0_CORE0_INTR_CPSW0_MISC_INTR
R5FSS0_CORE0_INTR_IN_16	16	R5FSS0_CORE0_INTR_LIN0_INTR_0
R5FSS0_CORE0_INTR_IN_17	17	R5FSS0_CORE0_INTR_LIN0_INTR_1
R5FSS0_CORE0_INTR_IN_18	18	R5FSS0_CORE0_INTR_LIN1_INTR_0
R5FSS0_CORE0_INTR_IN_19	19	R5FSS0_CORE0_INTR_LIN1_INTR_1
R5FSS0_CORE0_INTR_IN_20	20	R5FSS0_CORE0_INTR_LIN2_INTR_0
R5FSS0_CORE0_INTR_IN_21	21	R5FSS0_CORE0_INTR_LIN2_INTR_1
R5FSS0_CORE0_INTR_IN_22	22	R5FSS0_CORE0_INTR_LIN3_INTR_0
R5FSS0_CORE0_INTR_IN_23	23	R5FSS0_CORE0_INTR_LIN3_INTR_1

Table 10-17. R5FSS0_CORE0 Interrupt Map (continued)

Interrupt Input Line	Interrupt ID	Source Interrupt
R5FSS0_CORE0_INTR_IN_24	24	R5FSS0_CORE0_INTR_LIN4_INTR_0
R5FSS0_CORE0_INTR_IN_25	25	R5FSS0_CORE0_INTR_LIN4_INTR_1
R5FSS0_CORE0_INTR_IN_26	26	R5FSS0_CORE0_INTR_MCAN0_EXT_TS_ROLLOVER_LVL_INT_0
R5FSS0_CORE0_INTR_IN_27	27	R5FSS0_CORE0_INTR_MCAN0_MCAN_LVL_INT_0
R5FSS0_CORE0_INTR_IN_28	28	R5FSS0_CORE0_INTR_MCAN0_MCAN_LVL_INT_1
R5FSS0_CORE0_INTR_IN_29	29	R5FSS0_CORE0_INTR_MCAN1_EXT_TS_ROLLOVER_LVL_INT_0
R5FSS0_CORE0_INTR_IN_30	30	R5FSS0_CORE0_INTR_MCAN1_MCAN_LVL_INT_0
R5FSS0_CORE0_INTR_IN_31	31	R5FSS0_CORE0_INTR_MCAN1_MCAN_LVL_INT_1
R5FSS0_CORE0_INTR_IN_32	32	R5FSS0_CORE0_INTR_MCAN2_EXT_TS_ROLLOVER_LVL_INT_0
R5FSS0_CORE0_INTR_IN_33	33	R5FSS0_CORE0_INTR_MCAN2_MCAN_LVL_INT_0
R5FSS0_CORE0_INTR_IN_34	34	R5FSS0_CORE0_INTR_MCAN2_MCAN_LVL_INT_1
R5FSS0_CORE0_INTR_IN_35	35	R5FSS0_CORE0_INTR_MCAN3_EXT_TS_ROLLOVER_LVL_INT_0
R5FSS0_CORE0_INTR_IN_36	36	R5FSS0_CORE0_INTR_MCAN3_MCAN_LVL_INT_0
R5FSS0_CORE0_INTR_IN_37	37	R5FSS0_CORE0_INTR_MCAN3_MCAN_LVL_INT_1
R5FSS0_CORE0_INTR_IN_38	38	R5FSS0_CORE0_INTR_UART0_IRQ
R5FSS0_CORE0_INTR_IN_39	39	R5FSS0_CORE0_INTR_UART1_IRQ
R5FSS0_CORE0_INTR_IN_40	40	R5FSS0_CORE0_INTR_UART2_IRQ
R5FSS0_CORE0_INTR_IN_41	41	R5FSS0_CORE0_INTR_UART3_IRQ
R5FSS0_CORE0_INTR_IN_42	42	R5FSS0_CORE0_INTR_UART4_IRQ
R5FSS0_CORE0_INTR_IN_43	43	R5FSS0_CORE0_INTR_UART5_IRQ
R5FSS0_CORE0_INTR_IN_44	44	R5FSS0_CORE0_INTR_I2C0_IRQ
R5FSS0_CORE0_INTR_IN_45	45	R5FSS0_CORE0_INTR_I2C1_IRQ
R5FSS0_CORE0_INTR_IN_46	46	R5FSS0_CORE0_INTR_I2C2_IRQ
R5FSS0_CORE0_INTR_IN_47	47	R5FSS0_CORE0_INTR_I2C3_IRQ
R5FSS0_CORE0_INTR_IN_48	48	R5FSS0_CORE0_INTR_DTHE_SHA_S_INT
R5FSS0_CORE0_INTR_IN_49	49	R5FSS0_CORE0_INTR_DTHE_SHA_P_INT
R5FSS0_CORE0_INTR_IN_50	50	R5FSS0_CORE0_INTR_DTHE_TRNG_INT

Table 10-17. R5FSS0_CORE0 Interrupt Map (continued)

Interrupt Input Line	Interrupt ID	Source Interrupt
R5FSS0_CORE0_INTR_IN_51	51	R5FSS0_CORE0_INTR_DTHE_PKAE_INT
R5FSS0_CORE0_INTR_IN_52	52	R5FSS0_CORE0_INTR_DTHE_AES_S_INT
R5FSS0_CORE0_INTR_IN_53	53	R5FSS0_CORE0_INTR_DTHE_AES_P_INT
R5FSS0_CORE0_INTR_IN_54	54	R5FSS0_CORE0_INTR_QSPI0_INT
R5FSS0_CORE0_INTR_IN_55	55	R5FSS0_CORE0_INTR_TPCC0_INTG
R5FSS0_CORE0_INTR_IN_56	56	R5FSS0_CORE0_INTR_TPCC0_INT_0
R5FSS0_CORE0_INTR_IN_57	57	R5FSS0_CORE0_INTR_TPCC0_INT_1
R5FSS0_CORE0_INTR_IN_58	58	R5FSS0_CORE0_INTR_TPCC0_INT_2
R5FSS0_CORE0_INTR_IN_59	59	R5FSS0_CORE0_INTR_TPCC0_INT_3
R5FSS0_CORE0_INTR_IN_60	60	R5FSS0_CORE0_INTR_TPCC0_INT_4
R5FSS0_CORE0_INTR_IN_61	61	R5FSS0_CORE0_INTR_TPCC0_INT_5
R5FSS0_CORE0_INTR_IN_62	62	R5FSS0_CORE0_INTR_TPCC0_INT_6
R5FSS0_CORE0_INTR_IN_63	63	R5FSS0_CORE0_INTR_TPCC0_INT_7
R5FSS0_CORE0_INTR_IN_64	64	R5FSS0_CORE0_INTR_TPCC0_ERRINT
R5FSS0_CORE0_INTR_IN_65	65	R5FSS0_CORE0_INTR_TPCC0_MPINT
R5FSS0_CORE0_INTR_IN_66	66	R5FSS0_CORE0_INTR_TPTC0_ERINT_0
R5FSS0_CORE0_INTR_IN_67	67	R5FSS0_CORE0_INTR_TPTC0_ERINT_1
R5FSS0_CORE0_INTR_IN_68	68	R5FSS0_CORE0_INTR_MCRC0_INT
R5FSS0_CORE0_INTR_IN_69	69	R5FSS0_CORE0_INTR_MPU_ADDR_ERRAGG
R5FSS0_CORE0_INTR_IN_70	70	R5FSS0_CORE0_INTR_MPU_PROT_ERRAGG
R5FSS0_CORE0_INTR_IN_71	71	R5FSS0_CORE0_INTR_PBIST_DONE
R5FSS0_CORE0_INTR_IN_72	72	R5FSS0_CORE0_INTR_TPCC0_INTAGGR
R5FSS0_CORE0_INTR_IN_73	73	R5FSS0_CORE0_INTR_TPCC0_ERRAGGR
R5FSS0_CORE0_INTR_IN_74	74	R5FSS0_CORE0_INTR_DCC0_DONE
R5FSS0_CORE0_INTR_IN_75	75	R5FSS0_CORE0_INTR_DCC1_DONE
R5FSS0_CORE0_INTR_IN_76	76	R5FSS0_CORE0_INTR_DCC2_DONE
R5FSS0_CORE0_INTR_IN_77	77	R5FSS0_CORE0_INTR_DCC3_DONE

Table 10-17. R5FSS0_CORE0 Interrupt Map (continued)

Interrupt Input Line	Interrupt ID	Source Interrupt
R5FSS0_CORE0_INTR_IN_78	78	R5FSS0_CORE0_INTR_MCSP10_INTR
R5FSS0_CORE0_INTR_IN_79	79	R5FSS0_CORE0_INTR_MCSP11_INTR
R5FSS0_CORE0_INTR_IN_80	80	R5FSS0_CORE0_INTR_MCSP12_INTR
R5FSS0_CORE0_INTR_IN_81	81	R5FSS0_CORE0_INTR_MCSP13_INTR
R5FSS0_CORE0_INTR_IN_82	82	R5FSS0_CORE0_INTR_MCSP14_INTR
R5FSS0_CORE0_INTR_IN_83	83	R5FSS0_CORE0_INTR_MMC0_INTR
R5FSS0_CORE0_INTR_IN_84	84	R5FSS0_CORE0_INTR_RT10_INTR_0
R5FSS0_CORE0_INTR_IN_85	85	R5FSS0_CORE0_INTR_RT10_INTR_1
R5FSS0_CORE0_INTR_IN_86	86	R5FSS0_CORE0_INTR_RT10_INTR_2
R5FSS0_CORE0_INTR_IN_87	87	R5FSS0_CORE0_INTR_RT10_INTR_3
R5FSS0_CORE0_INTR_IN_88	88	R5FSS0_CORE0_INTR_RESERVED88
R5FSS0_CORE0_INTR_IN_89	89	R5FSS0_CORE0_INTR_RT10_OVERFLOW_INT0
R5FSS0_CORE0_INTR_IN_90	90	R5FSS0_CORE0_INTR_RT10_OVERFLOW_INT1
R5FSS0_CORE0_INTR_IN_91	91	R5FSS0_CORE0_INTR_RT11_INTR_0
R5FSS0_CORE0_INTR_IN_92	92	R5FSS0_CORE0_INTR_RT11_INTR_1
R5FSS0_CORE0_INTR_IN_93	93	R5FSS0_CORE0_INTR_RT11_INTR_2
R5FSS0_CORE0_INTR_IN_94	94	R5FSS0_CORE0_INTR_RT11_INTR_3
R5FSS0_CORE0_INTR_IN_95	95	R5FSS0_CORE0_INTR_RESERVED95
R5FSS0_CORE0_INTR_IN_96	96	R5FSS0_CORE0_INTR_RT11_OVERFLOW_INT0
R5FSS0_CORE0_INTR_IN_97	97	R5FSS0_CORE0_INTR_RT11_OVERFLOW_INT1
R5FSS0_CORE0_INTR_IN_98	98	R5FSS0_CORE0_INTR_RT12_INTR_0
R5FSS0_CORE0_INTR_IN_99	99	R5FSS0_CORE0_INTR_RT12_INTR_1
R5FSS0_CORE0_INTR_IN_100	100	R5FSS0_CORE0_INTR_RT12_INTR_2
R5FSS0_CORE0_INTR_IN_101	101	R5FSS0_CORE0_INTR_RT12_INTR_3
R5FSS0_CORE0_INTR_IN_102	102	R5FSS0_CORE0_INTR_RESERVED102
R5FSS0_CORE0_INTR_IN_103	103	R5FSS0_CORE0_INTR_RT12_OVERFLOW_INT0
R5FSS0_CORE0_INTR_IN_104	104	R5FSS0_CORE0_INTR_RT12_OVERFLOW_INT1

Table 10-17. R5FSS0_CORE0 Interrupt Map (continued)

Interrupt Input Line	Interrupt ID	Source Interrupt
R5FSS0_CORE0_INTR_IN_105	105	R5FSS0_CORE0_INTR_RTI3_INTR_0
R5FSS0_CORE0_INTR_IN_106	106	R5FSS0_CORE0_INTR_RTI3_INTR_1
R5FSS0_CORE0_INTR_IN_107	107	R5FSS0_CORE0_INTR_RTI3_INTR_2
R5FSS0_CORE0_INTR_IN_108	108	R5FSS0_CORE0_INTR_RTI3_INTR_3
R5FSS0_CORE0_INTR_IN_109	109	R5FSS0_CORE0_INTR_RESERVED109
R5FSS0_CORE0_INTR_IN_110	110	R5FSS0_CORE0_INTR_RTI3_OVERFLOW_INT0
R5FSS0_CORE0_INTR_IN_111	111	R5FSS0_CORE0_INTR_RTI3_OVERFLOW_INT1
R5FSS0_CORE0_INTR_IN_112	112	R5FSS0_CORE0_INTR_RESERVED112
R5FSS0_CORE0_INTR_IN_113	113	R5FSS0_CORE0_INTR_ESM0_ESM_INT_CFG
R5FSS0_CORE0_INTR_IN_114	114	R5FSS0_CORE0_INTR_ESM0_ESM_INT_HI
R5FSS0_CORE0_INTR_IN_115	115	R5FSS0_CORE0_INTR_ESM0_ESM_INT_LOW
R5FSS0_CORE0_INTR_IN_116	116	R5FSS0_CORE0_INTR_R5SS0_COMMRX_0
R5FSS0_CORE0_INTR_IN_117	117	R5FSS0_CORE0_INTR_R5SS0_COMMTX_0
R5FSS0_CORE0_INTR_IN_118	118	R5FSS0_CORE0_INTR_R5SS0_CPU0_CTI_INT
R5FSS0_CORE0_INTR_IN_119	119	R5FSS0_CORE0_INTR_R5SS0_CPU0_VALFIQ
R5FSS0_CORE0_INTR_IN_120	120	R5FSS0_CORE0_INTR_R5SS0_CPU0_VALIRQ
R5FSS0_CORE0_INTR_IN_121	121	R5FSS0_CORE0_INTR_R5SS0_CPU1_CTI_INT
R5FSS0_CORE0_INTR_IN_122	122	R5FSS0_CORE0_INTR_R5SS1_CPU0_PMU_INT
R5FSS0_CORE0_INTR_IN_123	123	R5FSS0_CORE0_INTR_R5SS1_CPU1_PMU_INT
R5FSS0_CORE0_INTR_IN_124	124	R5FSS0_CORE0_INTR_MMR_ACC_ERRAGG
R5FSS0_CORE0_INTR_IN_125	125	R5FSS0_CORE0_INTR_R5SS0_LIVELOCK_1
R5FSS0_CORE0_INTR_IN_126	126	R5FSS0_CORE0_INTR_R5SS1_LIVELOCK_0
R5FSS0_CORE0_INTR_IN_127	127	R5FSS0_CORE0_INTR_R5SS1_LIVELOCK_1
R5FSS0_CORE0_INTR_IN_128	128	R5FSS0_CORE0_INTR_RTI_WDT0_NMI
R5FSS0_CORE0_INTR_IN_129	129	R5FSS0_CORE0_INTR_SW_IRQ
R5FSS0_CORE0_INTR_IN_130	130	R5FSS0_CORE0_INTR_R5SS0_CORE0_FPU_EXP
R5FSS0_CORE0_INTR_IN_131	131	R5FSS0_CORE0_INTR_DEBUGSS_TXDATA_AVAIL

Table 10-17. R5FSS0_CORE0 Interrupt Map (continued)

Interrupt Input Line	Interrupt ID	Source Interrupt
R5FSS0_CORE0_INTR_IN_132	132	R5FSS0_CORE0_INTR_DEBUGSS_R5SS1_STC_DONE
R5FSS0_CORE0_INTR_IN_133	133	R5FSS0_CORE0_INTR_TSENSE_H
R5FSS0_CORE0_INTR_IN_134	134	R5FSS0_CORE0_INTR_TSENSE_L
R5FSS0_CORE0_INTR_IN_135	135	R5FSS0_CORE0_INTR_AHB_WRITE_ERR
R5FSS0_CORE0_INTR_IN_136	136	R5FSS0_CORE0_INTR_MBOX_READ_REQ
R5FSS0_CORE0_INTR_IN_137	137	R5FSS0_CORE0_INTR_MBOX_READ_ACK
R5FSS0_CORE0_INTR_IN_138	138	R5FSS0_CORE0_INTR_SOC_TIMESYNXBAR1_OUT_2
R5FSS0_CORE0_INTR_IN_139	139	R5FSS0_CORE0_INTR_SOC_TIMESYNXBAR1_OUT_3
R5FSS0_CORE0_INTR_IN_140	140	R5FSS0_CORE0_INTR_SOC_TIMESYNXBAR1_OUT_4
R5FSS0_CORE0_INTR_IN_141	141	R5FSS0_CORE0_INTR_SOC_TIMESYNXBAR1_OUT_5
R5FSS0_CORE0_INTR_IN_142	142	R5FSS0_CORE0_INTR_GPIO_INTRXBAR_OUT_14
R5FSS0_CORE0_INTR_IN_143	143	R5FSS0_CORE0_INTR_GPIO_INTRXBAR_OUT_15
R5FSS0_CORE0_INTR_IN_144	144	R5FSS0_CORE0_INTR_GPIO_INTRXBAR_OUT_16
R5FSS0_CORE0_INTR_IN_145	145	R5FSS0_CORE0_INTR_GPIO_INTRXBAR_OUT_17
R5FSS0_CORE0_INTR_IN_146	146	R5FSS0_CORE0_CONTROLSS_INTRXBAR0_OUT_0
R5FSS0_CORE0_INTR_IN_147	147	R5FSS0_CORE0_CONTROLSS_INTRXBAR0_OUT_1
R5FSS0_CORE0_INTR_IN_148	148	R5FSS0_CORE0_CONTROLSS_INTRXBAR0_OUT_2
R5FSS0_CORE0_INTR_IN_149	149	R5FSS0_CORE0_CONTROLSS_INTRXBAR0_OUT_3
R5FSS0_CORE0_INTR_IN_150	150	R5FSS0_CORE0_CONTROLSS_INTRXBAR0_OUT_4
R5FSS0_CORE0_INTR_IN_151	151	R5FSS0_CORE0_CONTROLSS_INTRXBAR0_OUT_5
R5FSS0_CORE0_INTR_IN_152	152	R5FSS0_CORE0_CONTROLSS_INTRXBAR0_OUT_6
R5FSS0_CORE0_INTR_IN_153	153	R5FSS0_CORE0_CONTROLSS_INTRXBAR0_OUT_7
R5FSS0_CORE0_INTR_IN_154	154	R5FSS0_CORE0_CONTROLSS_INTRXBAR0_OUT_8
R5FSS0_CORE0_INTR_IN_155	155	R5FSS0_CORE0_CONTROLSS_INTRXBAR0_OUT_9
R5FSS0_CORE0_INTR_IN_156	156	R5FSS0_CORE0_CONTROLSS_INTRXBAR0_OUT_10
R5FSS0_CORE0_INTR_IN_157	157	R5FSS0_CORE0_CONTROLSS_INTRXBAR0_OUT_11
R5FSS0_CORE0_INTR_IN_158	158	R5FSS0_CORE0_CONTROLSS_INTRXBAR0_OUT_12

Table 10-17. R5FSS0_CORE0 Interrupt Map (continued)

Interrupt Input Line	Interrupt ID	Source Interrupt
R5FSS0_CORE0_INTR_IN_159	159	R5FSS0_CORE0_CONTROLSS_INTRXBAR0_OUT_13
R5FSS0_CORE0_INTR_IN_160	160	R5FSS0_CORE0_CONTROLSS_INTRXBAR0_OUT_14
R5FSS0_CORE0_INTR_IN_161	161	R5FSS0_CORE0_CONTROLSS_INTRXBAR0_OUT_15
R5FSS0_CORE0_INTR_IN_162	162	R5FSS0_CORE0_CONTROLSS_INTRXBAR0_OUT_16
R5FSS0_CORE0_INTR_IN_163	163	R5FSS0_CORE0_CONTROLSS_INTRXBAR0_OUT_17
R5FSS0_CORE0_INTR_IN_164	164	R5FSS0_CORE0_CONTROLSS_INTRXBAR0_OUT_18
R5FSS0_CORE0_INTR_IN_165	165	R5FSS0_CORE0_CONTROLSS_INTRXBAR0_OUT_19
R5FSS0_CORE0_INTR_IN_166	166	R5FSS0_CORE0_CONTROLSS_INTRXBAR0_OUT_20
R5FSS0_CORE0_INTR_IN_167	167	R5FSS0_CORE0_CONTROLSS_INTRXBAR0_OUT_21
R5FSS0_CORE0_INTR_IN_168	168	R5FSS0_CORE0_CONTROLSS_INTRXBAR0_OUT_22
R5FSS0_CORE0_INTR_IN_169	169	R5FSS0_CORE0_CONTROLSS_INTRXBAR0_OUT_23
R5FSS0_CORE0_INTR_IN_170	170	R5FSS0_CORE0_CONTROLSS_INTRXBAR0_OUT_24
R5FSS0_CORE0_INTR_IN_171	171	R5FSS0_CORE0_CONTROLSS_INTRXBAR0_OUT_25
R5FSS0_CORE0_INTR_IN_172	172	R5FSS0_CORE0_CONTROLSS_INTRXBAR0_OUT_26
R5FSS0_CORE0_INTR_IN_173	173	R5FSS0_CORE0_CONTROLSS_INTRXBAR0_OUT_27
R5FSS0_CORE0_INTR_IN_174	174	R5FSS0_CORE0_CONTROLSS_INTRXBAR0_OUT_28
R5FSS0_CORE0_INTR_IN_175	175	R5FSS0_CORE0_CONTROLSS_INTRXBAR0_OUT_29
R5FSS0_CORE0_INTR_IN_176	176	R5FSS0_CORE0_CONTROLSS_INTRXBAR0_OUT_30
R5FSS0_CORE0_INTR_IN_177	177	R5FSS0_CORE0_CONTROLSS_INTRXBAR0_OUT_31
R5FSS0_CORE0_INTR_IN_178	178	R5FSS0_CORE0_INTR_PRU_ICSSM0_PR1_IEP0_CMP_INTR_REQ_0
R5FSS0_CORE0_INTR_IN_179	179	R5FSS0_CORE0_INTR_PRU_ICSSM0_PR1_IEP0_CMP_INTR_REQ_1
R5FSS0_CORE0_INTR_IN_180	180	R5FSS0_CORE0_INTR_PRU_ICSSM0_PR1_IEP0_CMP_INTR_REQ_2
R5FSS0_CORE0_INTR_IN_181	181	R5FSS0_CORE0_INTR_PRU_ICSSM0_PR1_IEP0_CMP_INTR_REQ_3
R5FSS0_CORE0_INTR_IN_182	182	R5FSS0_CORE0_INTR_PRU_ICSSM0_PR1_IEP0_CMP_INTR_REQ_4
R5FSS0_CORE0_INTR_IN_183	183	R5FSS0_CORE0_INTR_PRU_ICSSM0_PR1_IEP0_CMP_INTR_REQ_5
R5FSS0_CORE0_INTR_IN_184	184	R5FSS0_CORE0_INTR_PRU_ICSSM0_PR1_IEP0_CMP_INTR_REQ_6
R5FSS0_CORE0_INTR_IN_185	185	R5FSS0_CORE0_INTR_PRU_ICSSM0_PR1_IEP0_CMP_INTR_REQ_7

Table 10-17. R5FSS0_CORE0 Interrupt Map (continued)

Interrupt Input Line	Interrupt ID	Source Interrupt
R5FSS0_CORE0_INTR_IN_186	186	R5FSS0_CORE0_INTR_PRU_ICSSM0_PR1_IEP0_CMP_INTR_REQ_8
R5FSS0_CORE0_INTR_IN_187	187	R5FSS0_CORE0_INTR_PRU_ICSSM0_PR1_IEP0_CMP_INTR_REQ_9
R5FSS0_CORE0_INTR_IN_188	188	R5FSS0_CORE0_INTR_PRU_ICSSM0_PR1_IEP0_CMP_INTR_REQ_10
R5FSS0_CORE0_INTR_IN_189	189	R5FSS0_CORE0_INTR_PRU_ICSSM0_PR1_IEP0_CMP_INTR_REQ_11
R5FSS0_CORE0_INTR_IN_190	190	R5FSS0_CORE0_INTR_PRU_ICSSM0_PR1_IEP0_CMP_INTR_REQ_12
R5FSS0_CORE0_INTR_IN_191	191	R5FSS0_CORE0_INTR_PRU_ICSSM0_PR1_IEP0_CMP_INTR_REQ_13
R5FSS0_CORE0_INTR_IN_192	192	R5FSS0_CORE0_INTR_PRU_ICSSM0_PR1_IEP0_CMP_INTR_REQ_14
R5FSS0_CORE0_INTR_IN_193	193	R5FSS0_CORE0_INTR_PRU_ICSSM0_PR1_IEP0_CMP_INTR_REQ_15
R5FSS0_CORE0_INTR_IN_194	194	R5FSS0_CORE0_CPSW0_CPTS_COMP
R5FSS0_CORE0_INTR_IN_195	195	R5FSS0_CORE0_GPMC_SINTR
R5FSS0_CORE0_INTR_IN_196	196	R5FSS0_CORE0_ELM_SINTR

10.4.2 R5FSS0_CORE1 Interrupt Map

Table 10-18 shows the mapping of events to the R5FSS0_CORE1.

Both R5FSS0_CORE1 and R5FSS0_CORE0 use the R5FSS0_CORE0 interrupt map when operating in lockstep mode.

Table 10-18. R5FSS0_CORE1 Interrupt Map

Interrupt Input Line	Interrupt ID	Source Interrupt
R5FSS0_CORE1_INTR_IN_0	0	R5FSS0_CORE1_INTR_PRU_ICSSM0_PR1_HOST_INTR_PEND_0
R5FSS0_CORE1_INTR_IN_1	1	R5FSS0_CORE1_INTR_PRU_ICSSM0_PR1_HOST_INTR_PEND_1
R5FSS0_CORE1_INTR_IN_2	2	R5FSS0_CORE1_INTR_PRU_ICSSM0_PR1_HOST_INTR_PEND_2
R5FSS0_CORE1_INTR_IN_3	3	R5FSS0_CORE1_INTR_PRU_ICSSM0_PR1_HOST_INTR_PEND_3
R5FSS0_CORE1_INTR_IN_4	4	R5FSS0_CORE1_INTR_PRU_ICSSM0_PR1_HOST_INTR_PEND_4
R5FSS0_CORE1_INTR_IN_5	5	R5FSS0_CORE1_INTR_PRU_ICSSM0_PR1_HOST_INTR_PEND_5
R5FSS0_CORE1_INTR_IN_6	6	R5FSS0_CORE1_INTR_PRU_ICSSM0_PR1_HOST_INTR_PEND_6
R5FSS0_CORE1_INTR_IN_7	7	R5FSS0_CORE1_INTR_PRU_ICSSM0_PR1_HOST_INTR_PEND_7
R5FSS0_CORE1_INTR_IN_8	8	R5FSS0_CORE1_INTR_PRU_ICSSM0_PR1_RX_SOF_INTR_REQ_0
R5FSS0_CORE1_INTR_IN_9	9	R5FSS0_CORE1_INTR_PRU_ICSSM0_PR1_RX_SOF_INTR_REQ_1
R5FSS0_CORE1_INTR_IN_10	10	R5FSS0_CORE1_INTR_PRU_ICSSM0_PR1_TX_SOF_INTR_REQ_0
R5FSS0_CORE1_INTR_IN_11	11	R5FSS0_CORE1_INTR_PRU_ICSSM0_PR1_TX_SOF_INTR_REQ_1
R5FSS0_CORE1_INTR_IN_12	12	R5FSS0_CORE1_INTR_CPSW0_FH_INTR
R5FSS0_CORE1_INTR_IN_13	13	R5FSS0_CORE1_INTR_CPSW0_TH_INTR
R5FSS0_CORE1_INTR_IN_14	14	R5FSS0_CORE1_INTR_CPSW0_TH_THRESH_INTR
R5FSS0_CORE1_INTR_IN_15	15	R5FSS0_CORE1_INTR_CPSW0_MISC_INTR
R5FSS0_CORE1_INTR_IN_16	16	R5FSS0_CORE1_INTR_LIN0_INTR_0
R5FSS0_CORE1_INTR_IN_17	17	R5FSS0_CORE1_INTR_LIN0_INTR_1
R5FSS0_CORE1_INTR_IN_18	18	R5FSS0_CORE1_INTR_LIN1_INTR_0
R5FSS0_CORE1_INTR_IN_19	19	R5FSS0_CORE1_INTR_LIN1_INTR_1
R5FSS0_CORE1_INTR_IN_20	20	R5FSS0_CORE1_INTR_LIN2_INTR_0
R5FSS0_CORE1_INTR_IN_21	21	R5FSS0_CORE1_INTR_LIN2_INTR_1
R5FSS0_CORE1_INTR_IN_22	22	R5FSS0_CORE1_INTR_LIN3_INTR_0
R5FSS0_CORE1_INTR_IN_23	23	R5FSS0_CORE1_INTR_LIN3_INTR_1

Table 10-18. R5FSS0_CORE1 Interrupt Map (continued)

Interrupt Input Line	Interrupt ID	Source Interrupt
R5FSS0_CORE1_INTR_IN_24	24	R5FSS0_CORE1_INTR_LIN4_INTR_0
R5FSS0_CORE1_INTR_IN_25	25	R5FSS0_CORE1_INTR_LIN4_INTR_1
R5FSS0_CORE1_INTR_IN_26	26	R5FSS0_CORE1_INTR_MCAN0_EXT_TS_ROLLOVER_LVL_INT_0
R5FSS0_CORE1_INTR_IN_27	27	R5FSS0_CORE1_INTR_MCAN0_MCAN_LVL_INT_0
R5FSS0_CORE1_INTR_IN_28	28	R5FSS0_CORE1_INTR_MCAN0_MCAN_LVL_INT_1
R5FSS0_CORE1_INTR_IN_29	29	R5FSS0_CORE1_INTR_MCAN1_EXT_TS_ROLLOVER_LVL_INT_0
R5FSS0_CORE1_INTR_IN_30	30	R5FSS0_CORE1_INTR_MCAN1_MCAN_LVL_INT_0
R5FSS0_CORE1_INTR_IN_31	31	R5FSS0_CORE1_INTR_MCAN1_MCAN_LVL_INT_1
R5FSS0_CORE1_INTR_IN_32	32	R5FSS0_CORE1_INTR_MCAN2_EXT_TS_ROLLOVER_LVL_INT_0
R5FSS0_CORE1_INTR_IN_33	33	R5FSS0_CORE1_INTR_MCAN2_MCAN_LVL_INT_0
R5FSS0_CORE1_INTR_IN_34	34	R5FSS0_CORE1_INTR_MCAN2_MCAN_LVL_INT_1
R5FSS0_CORE1_INTR_IN_35	35	R5FSS0_CORE1_INTR_MCAN3_EXT_TS_ROLLOVER_LVL_INT_0
R5FSS0_CORE1_INTR_IN_36	36	R5FSS0_CORE1_INTR_MCAN3_MCAN_LVL_INT_0
R5FSS0_CORE1_INTR_IN_37	37	R5FSS0_CORE1_INTR_MCAN3_MCAN_LVL_INT_1
R5FSS0_CORE1_INTR_IN_38	38	R5FSS0_CORE1_INTR_UART0_IRQ
R5FSS0_CORE1_INTR_IN_39	39	R5FSS0_CORE1_INTR_UART1_IRQ
R5FSS0_CORE1_INTR_IN_40	40	R5FSS0_CORE1_INTR_UART2_IRQ
R5FSS0_CORE1_INTR_IN_41	41	R5FSS0_CORE1_INTR_UART3_IRQ
R5FSS0_CORE1_INTR_IN_42	42	R5FSS0_CORE1_INTR_UART4_IRQ
R5FSS0_CORE1_INTR_IN_43	43	R5FSS0_CORE1_INTR_UART5_IRQ
R5FSS0_CORE1_INTR_IN_44	44	R5FSS0_CORE1_INTR_I2C0_IRQ
R5FSS0_CORE1_INTR_IN_45	45	R5FSS0_CORE1_INTR_I2C1_IRQ
R5FSS0_CORE1_INTR_IN_46	46	R5FSS0_CORE1_INTR_I2C2_IRQ
R5FSS0_CORE1_INTR_IN_47	47	R5FSS0_CORE1_INTR_I2C3_IRQ
R5FSS0_CORE1_INTR_IN_48	48	R5FSS0_CORE1_INTR_DTHE_SHA_S_INT
R5FSS0_CORE1_INTR_IN_49	49	R5FSS0_CORE1_INTR_DTHE_SHA_P_INT
R5FSS0_CORE1_INTR_IN_50	50	R5FSS0_CORE1_INTR_DTHE_TRNG_INT

Table 10-18. R5FSS0_CORE1 Interrupt Map (continued)

Interrupt Input Line	Interrupt ID	Source Interrupt
R5FSS0_CORE1_INTR_IN_51	51	R5FSS0_CORE1_INTR_DTHE_PKAE_INT
R5FSS0_CORE1_INTR_IN_52	52	R5FSS0_CORE1_INTR_DTHE_AES_S_INT
R5FSS0_CORE1_INTR_IN_53	53	R5FSS0_CORE1_INTR_DTHE_AES_P_INT
R5FSS0_CORE1_INTR_IN_54	54	R5FSS0_CORE1_INTR_QSPI0_INT
R5FSS0_CORE1_INTR_IN_55	55	R5FSS0_CORE1_INTR_TPCC0_INTG
R5FSS0_CORE1_INTR_IN_56	56	R5FSS0_CORE1_INTR_TPCC0_INT_0
R5FSS0_CORE1_INTR_IN_57	57	R5FSS0_CORE1_INTR_TPCC0_INT_1
R5FSS0_CORE1_INTR_IN_58	58	R5FSS0_CORE1_INTR_TPCC0_INT_2
R5FSS0_CORE1_INTR_IN_59	59	R5FSS0_CORE1_INTR_TPCC0_INT_3
R5FSS0_CORE1_INTR_IN_60	60	R5FSS0_CORE1_INTR_TPCC0_INT_4
R5FSS0_CORE1_INTR_IN_61	61	R5FSS0_CORE1_INTR_TPCC0_INT_5
R5FSS0_CORE1_INTR_IN_62	62	R5FSS0_CORE1_INTR_TPCC0_INT_6
R5FSS0_CORE1_INTR_IN_63	63	R5FSS0_CORE1_INTR_TPCC0_INT_7
R5FSS0_CORE1_INTR_IN_64	64	R5FSS0_CORE1_INTR_TPCC0_ERRINT
R5FSS0_CORE1_INTR_IN_65	65	R5FSS0_CORE1_INTR_TPCC0_MPINT
R5FSS0_CORE1_INTR_IN_66	66	R5FSS0_CORE1_INTR_TPTC0_ERINT_0
R5FSS0_CORE1_INTR_IN_67	67	R5FSS0_CORE1_INTR_TPTC0_ERINT_1
R5FSS0_CORE1_INTR_IN_68	68	R5FSS0_CORE1_INTR_MCRC0_INT
R5FSS0_CORE1_INTR_IN_69	69	R5FSS0_CORE1_INTR_MPU_ADDR_ERRAGG
R5FSS0_CORE1_INTR_IN_70	70	R5FSS0_CORE1_INTR_MPU_PROT_ERRAGG
R5FSS0_CORE1_INTR_IN_71	71	R5FSS0_CORE1_INTR_PBIST_DONE
R5FSS0_CORE1_INTR_IN_72	72	R5FSS0_CORE1_INTR_TPCC0_INTAGGR
R5FSS0_CORE1_INTR_IN_73	73	R5FSS0_CORE1_INTR_TPCC0_ERRAGGR
R5FSS0_CORE1_INTR_IN_74	74	R5FSS0_CORE1_INTR_DCC0_DONE
R5FSS0_CORE1_INTR_IN_75	75	R5FSS0_CORE1_INTR_DCC1_DONE
R5FSS0_CORE1_INTR_IN_76	76	R5FSS0_CORE1_INTR_DCC2_DONE
R5FSS0_CORE1_INTR_IN_77	77	R5FSS0_CORE1_INTR_DCC3_DONE

Table 10-18. R5FSS0_CORE1 Interrupt Map (continued)

Interrupt Input Line	Interrupt ID	Source Interrupt
R5FSS0_CORE1_INTR_IN_78	78	R5FSS0_CORE1_INTR_MCSPi0_INTR
R5FSS0_CORE1_INTR_IN_79	79	R5FSS0_CORE1_INTR_MCSPi1_INTR
R5FSS0_CORE1_INTR_IN_80	80	R5FSS0_CORE1_INTR_MCSPi2_INTR
R5FSS0_CORE1_INTR_IN_81	81	R5FSS0_CORE1_INTR_MCSPi3_INTR
R5FSS0_CORE1_INTR_IN_82	82	R5FSS0_CORE1_INTR_MCSPi4_INTR
R5FSS0_CORE1_INTR_IN_83	83	R5FSS0_CORE1_INTR_MMC0_INTR
R5FSS0_CORE1_INTR_IN_84	84	R5FSS0_CORE1_INTR_RTIO_INTR_0
R5FSS0_CORE1_INTR_IN_85	85	R5FSS0_CORE1_INTR_RTIO_INTR_1
R5FSS0_CORE1_INTR_IN_86	86	R5FSS0_CORE1_INTR_RTIO_INTR_2
R5FSS0_CORE1_INTR_IN_87	87	R5FSS0_CORE1_INTR_RTIO_INTR_3
R5FSS0_CORE1_INTR_IN_88	88	R5FSS0_CORE1_INTR_RESERVED88
R5FSS0_CORE1_INTR_IN_89	89	R5FSS0_CORE1_INTR_RTIO_OVERFLOW_INT0
R5FSS0_CORE1_INTR_IN_90	90	R5FSS0_CORE1_INTR_RTIO_OVERFLOW_INT1
R5FSS0_CORE1_INTR_IN_91	91	R5FSS0_CORE1_INTR_RT11_INTR_0
R5FSS0_CORE1_INTR_IN_92	92	R5FSS0_CORE1_INTR_RT11_INTR_1
R5FSS0_CORE1_INTR_IN_93	93	R5FSS0_CORE1_INTR_RT11_INTR_2
R5FSS0_CORE1_INTR_IN_94	94	R5FSS0_CORE1_INTR_RT11_INTR_3
R5FSS0_CORE1_INTR_IN_95	95	R5FSS0_CORE1_INTR_RESERVED95
R5FSS0_CORE1_INTR_IN_96	96	R5FSS0_CORE1_INTR_RT11_OVERFLOW_INT0
R5FSS0_CORE1_INTR_IN_97	97	R5FSS0_CORE1_INTR_RT11_OVERFLOW_INT1
R5FSS0_CORE1_INTR_IN_98	98	R5FSS0_CORE1_INTR_RT12_INTR_0
R5FSS0_CORE1_INTR_IN_99	99	R5FSS0_CORE1_INTR_RT12_INTR_1
R5FSS0_CORE1_INTR_IN_100	100	R5FSS0_CORE1_INTR_RT12_INTR_2
R5FSS0_CORE1_INTR_IN_101	101	R5FSS0_CORE1_INTR_RT12_INTR_3
R5FSS0_CORE1_INTR_IN_102	102	R5FSS0_CORE1_INTR_RESERVED102
R5FSS0_CORE1_INTR_IN_103	103	R5FSS0_CORE1_INTR_RT12_OVERFLOW_INT0
R5FSS0_CORE1_INTR_IN_104	104	R5FSS0_CORE1_INTR_RT12_OVERFLOW_INT1

Table 10-18. R5FSS0_CORE1 Interrupt Map (continued)

Interrupt Input Line	Interrupt ID	Source Interrupt
R5FSS0_CORE1_INTR_IN_105	105	R5FSS0_CORE1_INTR_RTI3_INTR_0
R5FSS0_CORE1_INTR_IN_106	106	R5FSS0_CORE1_INTR_RTI3_INTR_1
R5FSS0_CORE1_INTR_IN_107	107	R5FSS0_CORE1_INTR_RTI3_INTR_2
R5FSS0_CORE1_INTR_IN_108	108	R5FSS0_CORE1_INTR_RTI3_INTR_3
R5FSS0_CORE1_INTR_IN_109	109	R5FSS0_CORE1_INTR_RESERVED109
R5FSS0_CORE1_INTR_IN_110	110	R5FSS0_CORE1_INTR_RTI3_OVERFLOW_INT0
R5FSS0_CORE1_INTR_IN_111	111	R5FSS0_CORE1_INTR_RTI3_OVERFLOW_INT1
R5FSS0_CORE1_INTR_IN_112	112	R5FSS0_CORE1_INTR_RESERVED112
R5FSS0_CORE1_INTR_IN_113	113	R5FSS0_CORE1_INTR_ESM0_ESM_INT_CFG
R5FSS0_CORE1_INTR_IN_114	114	R5FSS0_CORE1_INTR_ESM0_ESM_INT_HI
R5FSS0_CORE1_INTR_IN_115	115	R5FSS0_CORE1_INTR_ESM0_ESM_INT_LOW
R5FSS0_CORE1_INTR_IN_116	116	R5FSS0_CORE1_INTR_R5SS0_COMMRX_1
R5FSS0_CORE1_INTR_IN_117	117	R5FSS0_CORE1_INTR_R5SS0_COMMTX_1
R5FSS0_CORE1_INTR_IN_118	118	R5FSS0_CORE1_INTR_R5SS0_CPU0_CTI_INT
R5FSS0_CORE1_INTR_IN_119	119	R5FSS0_CORE1_INTR_R5SS0_CPU1_CTI_INT
R5FSS0_CORE1_INTR_IN_120	120	R5FSS0_CORE1_INTR_R5SS0_CPU1_VALFIQ
R5FSS0_CORE1_INTR_IN_121	121	R5FSS0_CORE1_INTR_R5SS0_CPU1_VALIRQ
R5FSS0_CORE1_INTR_IN_122	122	R5FSS0_CORE1_INTR_R5SS1_CPU0_PMU_INT
R5FSS0_CORE1_INTR_IN_123	123	R5FSS0_CORE1_INTR_R5SS1_CPU1_PMU_INT
R5FSS0_CORE1_INTR_IN_124	124	R5FSS0_CORE1_INTR_MMR_ACC_ERRAGG
R5FSS0_CORE1_INTR_IN_125	125	R5FSS0_CORE1_INTR_R5SS0_LIVELOCK_0
R5FSS0_CORE1_INTR_IN_126	126	R5FSS0_CORE1_INTR_R5SS1_LIVELOCK_0
R5FSS0_CORE1_INTR_IN_127	127	R5FSS0_CORE1_INTR_R5SS1_LIVELOCK_1
R5FSS0_CORE1_INTR_IN_128	128	R5FSS0_CORE1_INTR_RTI_WDT1_NMI
R5FSS0_CORE1_INTR_IN_129	129	R5FSS0_CORE1_INTR_SW_IRQ
R5FSS0_CORE1_INTR_IN_130	130	R5FSS0_CORE1_INTR_R5SS0_CORE1_FPU_EXP
R5FSS0_CORE1_INTR_IN_131	131	R5FSS0_CORE1_INTR_DEBUGSS_TXDATA_AVAIL

Table 10-18. R5FSS0_CORE1 Interrupt Map (continued)

Interrupt Input Line	Interrupt ID	Source Interrupt
R5FSS0_CORE1_INTR_IN_132	132	R5FSS0_CORE1_INTR_DEBUGSS_R5SS1_STC_DONE
R5FSS0_CORE1_INTR_IN_133	133	R5FSS0_CORE1_INTR_TSENSE_H
R5FSS0_CORE1_INTR_IN_134	134	R5FSS0_CORE1_INTR_TSENSE_L
R5FSS0_CORE1_INTR_IN_135	135	R5FSS0_CORE1_INTR_AHB_WRITE_ERR
R5FSS0_CORE1_INTR_IN_136	136	R5FSS0_CORE1_INTR_MBOX_READ_REQ
R5FSS0_CORE1_INTR_IN_137	137	R5FSS0_CORE1_INTR_MBOX_READ_ACK
R5FSS0_CORE1_INTR_IN_138	138	R5FSS0_CORE1_INTR_SOC_TIMESYNXBAR1_OUT_6
R5FSS0_CORE1_INTR_IN_139	139	R5FSS0_CORE1_INTR_SOC_TIMESYNXBAR1_OUT_7
R5FSS0_CORE1_INTR_IN_140	140	R5FSS0_CORE1_INTR_SOC_TIMESYNXBAR1_OUT_8
R5FSS0_CORE1_INTR_IN_141	141	R5FSS0_CORE1_INTR_SOC_TIMESYNXBAR1_OUT_9
R5FSS0_CORE1_INTR_IN_142	142	R5FSS0_CORE1_INTR_GPIO_INTRXBAR_OUT_18
R5FSS0_CORE1_INTR_IN_143	143	R5FSS0_CORE1_INTR_GPIO_INTRXBAR_OUT_19
R5FSS0_CORE1_INTR_IN_144	144	R5FSS0_CORE1_INTR_GPIO_INTRXBAR_OUT_20
R5FSS0_CORE1_INTR_IN_145	145	R5FSS0_CORE1_INTR_GPIO_INTRXBAR_OUT_21
R5FSS0_CORE1_INTR_IN_146	146	R5FSS0_CORE1_CONTROLSS_INTRXBAR0_OUT_0
R5FSS0_CORE1_INTR_IN_147	147	R5FSS0_CORE1_CONTROLSS_INTRXBAR0_OUT_1
R5FSS0_CORE1_INTR_IN_148	148	R5FSS0_CORE1_CONTROLSS_INTRXBAR0_OUT_2
R5FSS0_CORE1_INTR_IN_149	149	R5FSS0_CORE1_CONTROLSS_INTRXBAR0_OUT_3
R5FSS0_CORE1_INTR_IN_150	150	R5FSS0_CORE1_CONTROLSS_INTRXBAR0_OUT_4
R5FSS0_CORE1_INTR_IN_151	151	R5FSS0_CORE1_CONTROLSS_INTRXBAR0_OUT_5
R5FSS0_CORE1_INTR_IN_152	152	R5FSS0_CORE1_CONTROLSS_INTRXBAR0_OUT_6
R5FSS0_CORE1_INTR_IN_153	153	R5FSS0_CORE1_CONTROLSS_INTRXBAR0_OUT_7
R5FSS0_CORE1_INTR_IN_154	154	R5FSS0_CORE1_CONTROLSS_INTRXBAR0_OUT_8
R5FSS0_CORE1_INTR_IN_155	155	R5FSS0_CORE1_CONTROLSS_INTRXBAR0_OUT_9
R5FSS0_CORE1_INTR_IN_156	156	R5FSS0_CORE1_CONTROLSS_INTRXBAR0_OUT_10
R5FSS0_CORE1_INTR_IN_157	157	R5FSS0_CORE1_CONTROLSS_INTRXBAR0_OUT_11
R5FSS0_CORE1_INTR_IN_158	158	R5FSS0_CORE1_CONTROLSS_INTRXBAR0_OUT_12

Table 10-18. R5FSS0_CORE1 Interrupt Map (continued)

Interrupt Input Line	Interrupt ID	Source Interrupt
R5FSS0_CORE1_INTR_IN_159	159	R5FSS0_CORE1_CONTROLSS_INTRXBAR0_OUT_13
R5FSS0_CORE1_INTR_IN_160	160	R5FSS0_CORE1_CONTROLSS_INTRXBAR0_OUT_14
R5FSS0_CORE1_INTR_IN_161	161	R5FSS0_CORE1_CONTROLSS_INTRXBAR0_OUT_15
R5FSS0_CORE1_INTR_IN_162	162	R5FSS0_CORE1_CONTROLSS_INTRXBAR0_OUT_16
R5FSS0_CORE1_INTR_IN_163	163	R5FSS0_CORE1_CONTROLSS_INTRXBAR0_OUT_17
R5FSS0_CORE1_INTR_IN_164	164	R5FSS0_CORE1_CONTROLSS_INTRXBAR0_OUT_18
R5FSS0_CORE1_INTR_IN_165	165	R5FSS0_CORE1_CONTROLSS_INTRXBAR0_OUT_19
R5FSS0_CORE1_INTR_IN_166	166	R5FSS0_CORE1_CONTROLSS_INTRXBAR0_OUT_20
R5FSS0_CORE1_INTR_IN_167	167	R5FSS0_CORE1_CONTROLSS_INTRXBAR0_OUT_21
R5FSS0_CORE1_INTR_IN_168	168	R5FSS0_CORE1_CONTROLSS_INTRXBAR0_OUT_22
R5FSS0_CORE1_INTR_IN_169	169	R5FSS0_CORE1_CONTROLSS_INTRXBAR0_OUT_23
R5FSS0_CORE1_INTR_IN_170	170	R5FSS0_CORE1_CONTROLSS_INTRXBAR0_OUT_24
R5FSS0_CORE1_INTR_IN_171	171	R5FSS0_CORE1_CONTROLSS_INTRXBAR0_OUT_25
R5FSS0_CORE1_INTR_IN_172	172	R5FSS0_CORE1_CONTROLSS_INTRXBAR0_OUT_26
R5FSS0_CORE1_INTR_IN_173	173	R5FSS0_CORE1_CONTROLSS_INTRXBAR0_OUT_27
R5FSS0_CORE1_INTR_IN_174	174	R5FSS0_CORE1_CONTROLSS_INTRXBAR0_OUT_28
R5FSS0_CORE1_INTR_IN_175	175	R5FSS0_CORE1_CONTROLSS_INTRXBAR0_OUT_29
R5FSS0_CORE1_INTR_IN_176	176	R5FSS0_CORE1_CONTROLSS_INTRXBAR0_OUT_30
R5FSS0_CORE1_INTR_IN_177	177	R5FSS0_CORE1_CONTROLSS_INTRXBAR0_OUT_31
R5FSS0_CORE1_INTR_IN_178	178	R5FSS0_CORE1_INTR_PRU_ICSSM0_PR1_IEP0_CMP_INTR_REQ_0
R5FSS0_CORE1_INTR_IN_179	179	R5FSS0_CORE1_INTR_PRU_ICSSM0_PR1_IEP0_CMP_INTR_REQ_1
R5FSS0_CORE1_INTR_IN_180	180	R5FSS0_CORE1_INTR_PRU_ICSSM0_PR1_IEP0_CMP_INTR_REQ_2
R5FSS0_CORE1_INTR_IN_181	181	R5FSS0_CORE1_INTR_PRU_ICSSM0_PR1_IEP0_CMP_INTR_REQ_3
R5FSS0_CORE1_INTR_IN_182	182	R5FSS0_CORE1_INTR_PRU_ICSSM0_PR1_IEP0_CMP_INTR_REQ_4
R5FSS0_CORE1_INTR_IN_183	183	R5FSS0_CORE1_INTR_PRU_ICSSM0_PR1_IEP0_CMP_INTR_REQ_5
R5FSS0_CORE1_INTR_IN_184	184	R5FSS0_CORE1_INTR_PRU_ICSSM0_PR1_IEP0_CMP_INTR_REQ_6
R5FSS0_CORE1_INTR_IN_185	185	R5FSS0_CORE1_INTR_PRU_ICSSM0_PR1_IEP0_CMP_INTR_REQ_7

Table 10-18. R5FSS0_CORE1 Interrupt Map (continued)

Interrupt Input Line	Interrupt ID	Source Interrupt
R5FSS0_CORE1_INTR_IN_186	186	R5FSS0_CORE1_INTR_PRU_ICSSM0_PR1_IEP0_CMP_INTR_REQ_8
R5FSS0_CORE1_INTR_IN_187	187	R5FSS0_CORE1_INTR_PRU_ICSSM0_PR1_IEP0_CMP_INTR_REQ_9
R5FSS0_CORE1_INTR_IN_188	188	R5FSS0_CORE1_INTR_PRU_ICSSM0_PR1_IEP0_CMP_INTR_REQ_10
R5FSS0_CORE1_INTR_IN_189	189	R5FSS0_CORE1_INTR_PRU_ICSSM0_PR1_IEP0_CMP_INTR_REQ_11
R5FSS0_CORE1_INTR_IN_190	190	R5FSS0_CORE1_INTR_PRU_ICSSM0_PR1_IEP0_CMP_INTR_REQ_12
R5FSS0_CORE1_INTR_IN_191	191	R5FSS0_CORE1_INTR_PRU_ICSSM0_PR1_IEP0_CMP_INTR_REQ_13
R5FSS0_CORE1_INTR_IN_192	192	R5FSS0_CORE1_INTR_PRU_ICSSM0_PR1_IEP0_CMP_INTR_REQ_14
R5FSS0_CORE1_INTR_IN_193	193	R5FSS0_CORE1_INTR_PRU_ICSSM0_PR1_IEP0_CMP_INTR_REQ_15
R5FSS0_CORE1_INTR_IN_194	194	R5FSS0_CORE1_CPSW0_CPTS_COMP
R5FSS0_CORE1_INTR_IN_195	195	R5FSS0_CORE1_GPMC_SINTR
R5FSS0_CORE1_INTR_IN_196	196	R5FSS0_CORE1_ELM_SINTR

10.4.3 R5FSS1_CORE0 Interrupt Map

Table 10-19 shows the mapping of events to the R5FSS1_CORE0.

Both R5FSS1_CORE0 and R5FSS1_CORE1 use the R5FSS1_CORE0 interrupt map when operating in lockstep mode.

Table 10-19. R5FSS1_CORE0 Interrupt Map

Interrupt Input Line	Interrupt ID	Source Interrupt
R5FSS1_CORE0_INTR_IN_0	0	R5FSS1_CORE0_INTR_PRU_ICSSM0_PR1_HOST_INTR_PEND_0
R5FSS1_CORE0_INTR_IN_1	1	R5FSS1_CORE0_INTR_PRU_ICSSM0_PR1_HOST_INTR_PEND_1
R5FSS1_CORE0_INTR_IN_2	2	R5FSS1_CORE0_INTR_PRU_ICSSM0_PR1_HOST_INTR_PEND_2
R5FSS1_CORE0_INTR_IN_3	3	R5FSS1_CORE0_INTR_PRU_ICSSM0_PR1_HOST_INTR_PEND_3
R5FSS1_CORE0_INTR_IN_4	4	R5FSS1_CORE0_INTR_PRU_ICSSM0_PR1_HOST_INTR_PEND_4
R5FSS1_CORE0_INTR_IN_5	5	R5FSS1_CORE0_INTR_PRU_ICSSM0_PR1_HOST_INTR_PEND_5
R5FSS1_CORE0_INTR_IN_6	6	R5FSS1_CORE0_INTR_PRU_ICSSM0_PR1_HOST_INTR_PEND_6
R5FSS1_CORE0_INTR_IN_7	7	R5FSS1_CORE0_INTR_PRU_ICSSM0_PR1_HOST_INTR_PEND_7
R5FSS1_CORE0_INTR_IN_8	8	R5FSS1_CORE0_INTR_PRU_ICSSM0_PR1_RX_SOF_INTR_REQ_0
R5FSS1_CORE0_INTR_IN_9	9	R5FSS1_CORE0_INTR_PRU_ICSSM0_PR1_RX_SOF_INTR_REQ_1
R5FSS1_CORE0_INTR_IN_10	10	R5FSS1_CORE0_INTR_PRU_ICSSM0_PR1_TX_SOF_INTR_REQ_0
R5FSS1_CORE0_INTR_IN_11	11	R5FSS1_CORE0_INTR_PRU_ICSSM0_PR1_TX_SOF_INTR_REQ_1
R5FSS1_CORE0_INTR_IN_12	12	R5FSS1_CORE0_INTR_CPSW0_FH_INTR
R5FSS1_CORE0_INTR_IN_13	13	R5FSS1_CORE0_INTR_CPSW0_TH_INTR
R5FSS1_CORE0_INTR_IN_14	14	R5FSS1_CORE0_INTR_CPSW0_TH_THRESH_INTR
R5FSS1_CORE0_INTR_IN_15	15	R5FSS1_CORE0_INTR_CPSW0_MISC_INTR
R5FSS1_CORE0_INTR_IN_16	16	R5FSS1_CORE0_INTR_LIN0_INTR_0
R5FSS1_CORE0_INTR_IN_17	17	R5FSS1_CORE0_INTR_LIN0_INTR_1
R5FSS1_CORE0_INTR_IN_18	18	R5FSS1_CORE0_INTR_LIN1_INTR_0
R5FSS1_CORE0_INTR_IN_19	19	R5FSS1_CORE0_INTR_LIN1_INTR_1
R5FSS1_CORE0_INTR_IN_20	20	R5FSS1_CORE0_INTR_LIN2_INTR_0
R5FSS1_CORE0_INTR_IN_21	21	R5FSS1_CORE0_INTR_LIN2_INTR_1
R5FSS1_CORE0_INTR_IN_22	22	R5FSS1_CORE0_INTR_LIN3_INTR_0
R5FSS1_CORE0_INTR_IN_23	23	R5FSS1_CORE0_INTR_LIN3_INTR_1
R5FSS1_CORE0_INTR_IN_24	24	R5FSS1_CORE0_INTR_LIN4_INTR_0
R5FSS1_CORE0_INTR_IN_25	25	R5FSS1_CORE0_INTR_LIN4_INTR_1
R5FSS1_CORE0_INTR_IN_26	26	R5FSS1_CORE0_INTR_MCAN0_EXT_TS_ROLLOVER_LVL_INT_0
R5FSS1_CORE0_INTR_IN_27	27	R5FSS1_CORE0_INTR_MCAN0_MCAN_LVL_INT_0
R5FSS1_CORE0_INTR_IN_28	28	R5FSS1_CORE0_INTR_MCAN0_MCAN_LVL_INT_1
R5FSS1_CORE0_INTR_IN_29	29	R5FSS1_CORE0_INTR_MCAN1_EXT_TS_ROLLOVER_LVL_INT_0
R5FSS1_CORE0_INTR_IN_30	30	R5FSS1_CORE0_INTR_MCAN1_MCAN_LVL_INT_0
R5FSS1_CORE0_INTR_IN_31	31	R5FSS1_CORE0_INTR_MCAN1_MCAN_LVL_INT_1
R5FSS1_CORE0_INTR_IN_32	32	R5FSS1_CORE0_INTR_MCAN2_EXT_TS_ROLLOVER_LVL_INT_0
R5FSS1_CORE0_INTR_IN_33	33	R5FSS1_CORE0_INTR_MCAN2_MCAN_LVL_INT_0
R5FSS1_CORE0_INTR_IN_34	34	R5FSS1_CORE0_INTR_MCAN2_MCAN_LVL_INT_1
R5FSS1_CORE0_INTR_IN_35	35	R5FSS1_CORE0_INTR_MCAN3_EXT_TS_ROLLOVER_LVL_INT_0
R5FSS1_CORE0_INTR_IN_36	36	R5FSS1_CORE0_INTR_MCAN3_MCAN_LVL_INT_0
R5FSS1_CORE0_INTR_IN_37	37	R5FSS1_CORE0_INTR_MCAN3_MCAN_LVL_INT_1
R5FSS1_CORE0_INTR_IN_38	38	R5FSS1_CORE0_INTR_UART0_IRQ
R5FSS1_CORE0_INTR_IN_39	39	R5FSS1_CORE0_INTR_UART1_IRQ
R5FSS1_CORE0_INTR_IN_40	40	R5FSS1_CORE0_INTR_UART2_IRQ

Table 10-19. R5FSS1_CORE0 Interrupt Map (continued)

Interrupt Input Line	Interrupt ID	Source Interrupt
R5FSS1_CORE0_INTR_IN_41	41	R5FSS1_CORE0_INTR_UART3_IRQ
R5FSS1_CORE0_INTR_IN_42	42	R5FSS1_CORE0_INTR_UART4_IRQ
R5FSS1_CORE0_INTR_IN_43	43	R5FSS1_CORE0_INTR_UART5_IRQ
R5FSS1_CORE0_INTR_IN_44	44	R5FSS1_CORE0_INTR_I2C0_IRQ
R5FSS1_CORE0_INTR_IN_45	45	R5FSS1_CORE0_INTR_I2C1_IRQ
R5FSS1_CORE0_INTR_IN_46	46	R5FSS1_CORE0_INTR_I2C2_IRQ
R5FSS1_CORE0_INTR_IN_47	47	R5FSS1_CORE0_INTR_I2C3_IRQ
R5FSS1_CORE0_INTR_IN_48	48	R5FSS1_CORE0_INTR_DTHE_SHA_S_INT
R5FSS1_CORE0_INTR_IN_49	49	R5FSS1_CORE0_INTR_DTHE_SHA_P_INT
R5FSS1_CORE0_INTR_IN_50	50	R5FSS1_CORE0_INTR_DTHE_TRNG_INT
R5FSS1_CORE0_INTR_IN_51	51	R5FSS1_CORE0_INTR_DTHE_PKAE_INT
R5FSS1_CORE0_INTR_IN_52	52	R5FSS1_CORE0_INTR_DTHE_AES_S_INT
R5FSS1_CORE0_INTR_IN_53	53	R5FSS1_CORE0_INTR_DTHE_AES_P_INT
R5FSS1_CORE0_INTR_IN_54	54	R5FSS1_CORE0_INTR_QSPI0_INT
R5FSS1_CORE0_INTR_IN_55	55	R5FSS1_CORE0_INTR_TPCC0_INTG
R5FSS1_CORE0_INTR_IN_56	56	R5FSS1_CORE0_INTR_TPCC0_INT_0
R5FSS1_CORE0_INTR_IN_57	57	R5FSS1_CORE0_INTR_TPCC0_INT_1
R5FSS1_CORE0_INTR_IN_58	58	R5FSS1_CORE0_INTR_TPCC0_INT_2
R5FSS1_CORE0_INTR_IN_59	59	R5FSS1_CORE0_INTR_TPCC0_INT_3
R5FSS1_CORE0_INTR_IN_60	60	R5FSS1_CORE0_INTR_TPCC0_INT_4
R5FSS1_CORE0_INTR_IN_61	61	R5FSS1_CORE0_INTR_TPCC0_INT_5
R5FSS1_CORE0_INTR_IN_62	62	R5FSS1_CORE0_INTR_TPCC0_INT_6
R5FSS1_CORE0_INTR_IN_63	63	R5FSS1_CORE0_INTR_TPCC0_INT_7
R5FSS1_CORE0_INTR_IN_64	64	R5FSS1_CORE0_INTR_TPCC0_ERRINT
R5FSS1_CORE0_INTR_IN_65	65	R5FSS1_CORE0_INTR_TPCC0_MPINT
R5FSS1_CORE0_INTR_IN_66	66	R5FSS1_CORE0_INTR_TPTC0_ERINT_0
R5FSS1_CORE0_INTR_IN_67	67	R5FSS1_CORE0_INTR_TPTC0_ERINT_1
R5FSS1_CORE0_INTR_IN_68	68	R5FSS1_CORE0_INTR_MCRC0_INT
R5FSS1_CORE0_INTR_IN_69	69	R5FSS1_CORE0_INTR_MPU_ADDR_ERRAGG
R5FSS1_CORE0_INTR_IN_70	70	R5FSS1_CORE0_INTR_MPU_PROT_ERRAGG
R5FSS1_CORE0_INTR_IN_71	71	R5FSS1_CORE0_INTR_PBIST_DONE
R5FSS1_CORE0_INTR_IN_72	72	R5FSS1_CORE0_INTR_TPCC0_INTAGGR
R5FSS1_CORE0_INTR_IN_73	73	R5FSS1_CORE0_INTR_TPCC0_ERRAGGR
R5FSS1_CORE0_INTR_IN_74	74	R5FSS1_CORE0_INTR_DCC0_DONE
R5FSS1_CORE0_INTR_IN_75	75	R5FSS1_CORE0_INTR_DCC1_DONE
R5FSS1_CORE0_INTR_IN_76	76	R5FSS1_CORE0_INTR_DCC2_DONE
R5FSS1_CORE0_INTR_IN_77	77	R5FSS1_CORE0_INTR_DCC3_DONE
R5FSS1_CORE0_INTR_IN_78	78	R5FSS1_CORE0_INTR_MCSPi0_INTR
R5FSS1_CORE0_INTR_IN_79	79	R5FSS1_CORE0_INTR_MCSPi1_INTR
R5FSS1_CORE0_INTR_IN_80	80	R5FSS1_CORE0_INTR_MCSPi2_INTR
R5FSS1_CORE0_INTR_IN_81	81	R5FSS1_CORE0_INTR_MCSPi3_INTR
R5FSS1_CORE0_INTR_IN_82	82	R5FSS1_CORE0_INTR_MCSPi4_INTR
R5FSS1_CORE0_INTR_IN_83	83	R5FSS1_CORE0_INTR_MMC0_INTR
R5FSS1_CORE0_INTR_IN_84	84	R5FSS1_CORE0_INTR_RTIO_INTR_0
R5FSS1_CORE0_INTR_IN_85	85	R5FSS1_CORE0_INTR_RTIO_INTR_1

Table 10-19. R5FSS1_CORE0 Interrupt Map (continued)

Interrupt Input Line	Interrupt ID	Source Interrupt
R5FSS1_CORE0_INTR_IN_86	86	R5FSS1_CORE0_INTR_RT10_INTR_2
R5FSS1_CORE0_INTR_IN_87	87	R5FSS1_CORE0_INTR_RT10_INTR_3
R5FSS1_CORE0_INTR_IN_88	88	R5FSS1_CORE0_INTR_RESERVED88
R5FSS1_CORE0_INTR_IN_89	89	R5FSS1_CORE0_INTR_RT10_OVERFLOW_INT0
R5FSS1_CORE0_INTR_IN_90	90	R5FSS1_CORE0_INTR_RT10_OVERFLOW_INT1
R5FSS1_CORE0_INTR_IN_91	91	R5FSS1_CORE0_INTR_RT11_INTR_0
R5FSS1_CORE0_INTR_IN_92	92	R5FSS1_CORE0_INTR_RT11_INTR_1
R5FSS1_CORE0_INTR_IN_93	93	R5FSS1_CORE0_INTR_RT11_INTR_2
R5FSS1_CORE0_INTR_IN_94	94	R5FSS1_CORE0_INTR_RT11_INTR_3
R5FSS1_CORE0_INTR_IN_95	95	R5FSS1_CORE0_INTR_RESERVED95
R5FSS1_CORE0_INTR_IN_96	96	R5FSS1_CORE0_INTR_RT11_OVERFLOW_INT0
R5FSS1_CORE0_INTR_IN_97	97	R5FSS1_CORE0_INTR_RT11_OVERFLOW_INT1
R5FSS1_CORE0_INTR_IN_98	98	R5FSS1_CORE0_INTR_RT12_INTR_0
R5FSS1_CORE0_INTR_IN_99	99	R5FSS1_CORE0_INTR_RT12_INTR_1
R5FSS1_CORE0_INTR_IN_100	100	R5FSS1_CORE0_INTR_RT12_INTR_2
R5FSS1_CORE0_INTR_IN_101	101	R5FSS1_CORE0_INTR_RT12_INTR_3
R5FSS1_CORE0_INTR_IN_102	102	R5FSS1_CORE0_INTR_RESERVED102
R5FSS1_CORE0_INTR_IN_103	103	R5FSS1_CORE0_INTR_RT12_OVERFLOW_INT0
R5FSS1_CORE0_INTR_IN_104	104	R5FSS1_CORE0_INTR_RT12_OVERFLOW_INT1
R5FSS1_CORE0_INTR_IN_105	105	R5FSS1_CORE0_INTR_RT13_INTR_0
R5FSS1_CORE0_INTR_IN_106	106	R5FSS1_CORE0_INTR_RT13_INTR_1
R5FSS1_CORE0_INTR_IN_107	107	R5FSS1_CORE0_INTR_RT13_INTR_2
R5FSS1_CORE0_INTR_IN_108	108	R5FSS1_CORE0_INTR_RT13_INTR_3
R5FSS1_CORE0_INTR_IN_109	109	R5FSS1_CORE0_INTR_RESERVED109
R5FSS1_CORE0_INTR_IN_110	110	R5FSS1_CORE0_INTR_RT13_OVERFLOW_INT0
R5FSS1_CORE0_INTR_IN_111	111	R5FSS1_CORE0_INTR_RT13_OVERFLOW_INT1
R5FSS1_CORE0_INTR_IN_112	112	R5FSS1_CORE0_INTR_RESERVED112
R5FSS1_CORE0_INTR_IN_113	113	R5FSS1_CORE0_INTR_ESM0_ESM_INT_CFG
R5FSS1_CORE0_INTR_IN_114	114	R5FSS1_CORE0_INTR_ESM0_ESM_INT_HI
R5FSS1_CORE0_INTR_IN_115	115	R5FSS1_CORE0_INTR_ESM0_ESM_INT_LOW
R5FSS1_CORE0_INTR_IN_116	116	R5FSS1_CORE0_INTR_R5SS0_CPU0_PMU_INT
R5FSS1_CORE0_INTR_IN_117	117	R5FSS1_CORE0_INTR_R5SS0_CPU1_PMU_INT
R5FSS1_CORE0_INTR_IN_118	118	R5FSS1_CORE0_INTR_R5SS1_COMMRX_0
R5FSS1_CORE0_INTR_IN_119	119	R5FSS1_CORE0_INTR_R5SS1_COMMTX_0
R5FSS1_CORE0_INTR_IN_120	120	R5FSS1_CORE0_INTR_R5SS1_CPU0_CT1_INT
R5FSS1_CORE0_INTR_IN_121	121	R5FSS1_CORE0_INTR_R5SS1_CPU0_VALFIQ
R5FSS1_CORE0_INTR_IN_122	122	R5FSS1_CORE0_INTR_R5SS1_CPU0_VALIRQ
R5FSS1_CORE0_INTR_IN_123	123	R5FSS1_CORE0_INTR_R5SS1_CPU1_CT1_INT
R5FSS1_CORE0_INTR_IN_124	124	R5FSS1_CORE0_INTR_MMR_ACC_ERRAGG
R5FSS1_CORE0_INTR_IN_125	125	R5FSS1_CORE0_INTR_R5SS1_LIVELOCK_1
R5FSS1_CORE0_INTR_IN_126	126	R5FSS1_CORE0_INTR_R5SS0_LIVELOCK_0
R5FSS1_CORE0_INTR_IN_127	127	R5FSS1_CORE0_INTR_R5SS0_LIVELOCK_1
R5FSS1_CORE0_INTR_IN_128	128	R5FSS1_CORE0_INTR_RT1_WDT2_NMI
R5FSS1_CORE0_INTR_IN_129	129	R5FSS1_CORE0_INTR_SW_IRQ
R5FSS1_CORE0_INTR_IN_130	130	R5FSS1_CORE0_INTR_R5SS1_CORE0_FPU_EXP

Table 10-19. R5FSS1_CORE0 Interrupt Map (continued)

Interrupt Input Line	Interrupt ID	Source Interrupt
R5FSS1_CORE0_INTR_IN_131	131	R5FSS1_CORE0_INTR_DEBUGSS_TXDATA_AVAIL
R5FSS1_CORE0_INTR_IN_132	132	R5FSS1_CORE0_INTR_DEBUGSS_R5SS0_STC_DONE
R5FSS1_CORE0_INTR_IN_133	133	R5FSS1_CORE0_INTR_TSENSE_H
R5FSS1_CORE0_INTR_IN_134	134	R5FSS1_CORE0_INTR_TSENSE_L
R5FSS1_CORE0_INTR_IN_135	135	R5FSS1_CORE0_INTR_AHB_WRITE_ERR
R5FSS1_CORE0_INTR_IN_136	136	R5FSS1_CORE0_INTR_MBOX_READ_REQ
R5FSS1_CORE0_INTR_IN_137	137	R5FSS1_CORE0_INTR_MBOX_READ_ACK
R5FSS1_CORE0_INTR_IN_138	138	R5FSS1_CORE0_INTR_SOC_TIMESYNXBAR1_OUT_26
R5FSS1_CORE0_INTR_IN_139	139	R5FSS1_CORE0_INTR_SOC_TIMESYNXBAR1_OUT_27
R5FSS1_CORE0_INTR_IN_140	140	R5FSS1_CORE0_INTR_SOC_TIMESYNXBAR1_OUT_28
R5FSS1_CORE0_INTR_IN_141	141	R5FSS1_CORE0_INTR_SOC_TIMESYNXBAR1_OUT_29
R5FSS1_CORE0_INTR_IN_142	142	R5FSS1_CORE0_INTR_GPIO_INTRXBAR_OUT_22
R5FSS1_CORE0_INTR_IN_143	143	R5FSS1_CORE0_INTR_GPIO_INTRXBAR_OUT_23
R5FSS1_CORE0_INTR_IN_144	144	R5FSS1_CORE0_INTR_GPIO_INTRXBAR_OUT_24
R5FSS1_CORE0_INTR_IN_145	145	R5FSS1_CORE0_INTR_GPIO_INTRXBAR_OUT_25
R5FSS1_CORE0_INTR_IN_146	146	R5FSS1_CORE0_CONTROLSS_INTRXBAR0_OUT_0
R5FSS1_CORE0_INTR_IN_147	147	R5FSS1_CORE0_CONTROLSS_INTRXBAR0_OUT_1
R5FSS1_CORE0_INTR_IN_148	148	R5FSS1_CORE0_CONTROLSS_INTRXBAR0_OUT_2
R5FSS1_CORE0_INTR_IN_149	149	R5FSS1_CORE0_CONTROLSS_INTRXBAR0_OUT_3
R5FSS1_CORE0_INTR_IN_150	150	R5FSS1_CORE0_CONTROLSS_INTRXBAR0_OUT_4
R5FSS1_CORE0_INTR_IN_151	151	R5FSS1_CORE0_CONTROLSS_INTRXBAR0_OUT_5
R5FSS1_CORE0_INTR_IN_152	152	R5FSS1_CORE0_CONTROLSS_INTRXBAR0_OUT_6
R5FSS1_CORE0_INTR_IN_153	153	R5FSS1_CORE0_CONTROLSS_INTRXBAR0_OUT_7
R5FSS1_CORE0_INTR_IN_154	154	R5FSS1_CORE0_CONTROLSS_INTRXBAR0_OUT_8
R5FSS1_CORE0_INTR_IN_155	155	R5FSS1_CORE0_CONTROLSS_INTRXBAR0_OUT_9
R5FSS1_CORE0_INTR_IN_156	156	R5FSS1_CORE0_CONTROLSS_INTRXBAR0_OUT_10
R5FSS1_CORE0_INTR_IN_157	157	R5FSS1_CORE0_CONTROLSS_INTRXBAR0_OUT_11
R5FSS1_CORE0_INTR_IN_158	158	R5FSS1_CORE0_CONTROLSS_INTRXBAR0_OUT_12
R5FSS1_CORE0_INTR_IN_159	159	R5FSS1_CORE0_CONTROLSS_INTRXBAR0_OUT_13
R5FSS1_CORE0_INTR_IN_160	160	R5FSS1_CORE0_CONTROLSS_INTRXBAR0_OUT_14
R5FSS1_CORE0_INTR_IN_161	161	R5FSS1_CORE0_CONTROLSS_INTRXBAR0_OUT_15
R5FSS1_CORE0_INTR_IN_162	162	R5FSS1_CORE0_CONTROLSS_INTRXBAR0_OUT_16
R5FSS1_CORE0_INTR_IN_163	163	R5FSS1_CORE0_CONTROLSS_INTRXBAR0_OUT_17
R5FSS1_CORE0_INTR_IN_164	164	R5FSS1_CORE0_CONTROLSS_INTRXBAR0_OUT_18
R5FSS1_CORE0_INTR_IN_165	165	R5FSS1_CORE0_CONTROLSS_INTRXBAR0_OUT_19
R5FSS1_CORE0_INTR_IN_166	166	R5FSS1_CORE0_CONTROLSS_INTRXBAR0_OUT_20
R5FSS1_CORE0_INTR_IN_167	167	R5FSS1_CORE0_CONTROLSS_INTRXBAR0_OUT_21
R5FSS1_CORE0_INTR_IN_168	168	R5FSS1_CORE0_CONTROLSS_INTRXBAR0_OUT_22
R5FSS1_CORE0_INTR_IN_169	169	R5FSS1_CORE0_CONTROLSS_INTRXBAR0_OUT_23
R5FSS1_CORE0_INTR_IN_170	170	R5FSS1_CORE0_CONTROLSS_INTRXBAR0_OUT_24
R5FSS1_CORE0_INTR_IN_171	171	R5FSS1_CORE0_CONTROLSS_INTRXBAR0_OUT_25
R5FSS1_CORE0_INTR_IN_172	172	R5FSS1_CORE0_CONTROLSS_INTRXBAR0_OUT_26
R5FSS1_CORE0_INTR_IN_173	173	R5FSS1_CORE0_CONTROLSS_INTRXBAR0_OUT_27
R5FSS1_CORE0_INTR_IN_174	174	R5FSS1_CORE0_CONTROLSS_INTRXBAR0_OUT_28
R5FSS1_CORE0_INTR_IN_175	175	R5FSS1_CORE0_CONTROLSS_INTRXBAR0_OUT_29

Table 10-19. R5FSS1_CORE0 Interrupt Map (continued)

Interrupt Input Line	Interrupt ID	Source Interrupt
R5FSS1_CORE0_INTR_IN_176	176	R5FSS1_CORE0_CONTROLSS_INTRXBAR0_OUT_30
R5FSS1_CORE0_INTR_IN_177	177	R5FSS1_CORE0_CONTROLSS_INTRXBAR0_OUT_31
R5FSS1_CORE0_INTR_IN_178	178	R5FSS1_CORE0_INTR_PRU_ICSSM0_PR1_IEP0_CMP_INTR_REQ_0
R5FSS1_CORE0_INTR_IN_179	179	R5FSS1_CORE0_INTR_PRU_ICSSM0_PR1_IEP0_CMP_INTR_REQ_1
R5FSS1_CORE0_INTR_IN_180	180	R5FSS1_CORE0_INTR_PRU_ICSSM0_PR1_IEP0_CMP_INTR_REQ_2
R5FSS1_CORE0_INTR_IN_181	181	R5FSS1_CORE0_INTR_PRU_ICSSM0_PR1_IEP0_CMP_INTR_REQ_3
R5FSS1_CORE0_INTR_IN_182	182	R5FSS1_CORE0_INTR_PRU_ICSSM0_PR1_IEP0_CMP_INTR_REQ_4
R5FSS1_CORE0_INTR_IN_183	183	R5FSS1_CORE0_INTR_PRU_ICSSM0_PR1_IEP0_CMP_INTR_REQ_5
R5FSS1_CORE0_INTR_IN_184	184	R5FSS1_CORE0_INTR_PRU_ICSSM0_PR1_IEP0_CMP_INTR_REQ_6
R5FSS1_CORE0_INTR_IN_185	185	R5FSS1_CORE0_INTR_PRU_ICSSM0_PR1_IEP0_CMP_INTR_REQ_7
R5FSS1_CORE0_INTR_IN_186	186	R5FSS1_CORE0_INTR_PRU_ICSSM0_PR1_IEP0_CMP_INTR_REQ_8
R5FSS1_CORE0_INTR_IN_187	187	R5FSS1_CORE0_INTR_PRU_ICSSM0_PR1_IEP0_CMP_INTR_REQ_9
R5FSS1_CORE0_INTR_IN_188	188	R5FSS1_CORE0_INTR_PRU_ICSSM0_PR1_IEP0_CMP_INTR_REQ_10
R5FSS1_CORE0_INTR_IN_189	189	R5FSS1_CORE0_INTR_PRU_ICSSM0_PR1_IEP0_CMP_INTR_REQ_11
R5FSS1_CORE0_INTR_IN_190	190	R5FSS1_CORE0_INTR_PRU_ICSSM0_PR1_IEP0_CMP_INTR_REQ_12
R5FSS1_CORE0_INTR_IN_191	191	R5FSS1_CORE0_INTR_PRU_ICSSM0_PR1_IEP0_CMP_INTR_REQ_13
R5FSS1_CORE0_INTR_IN_192	192	R5FSS1_CORE0_INTR_PRU_ICSSM0_PR1_IEP0_CMP_INTR_REQ_14
R5FSS1_CORE0_INTR_IN_193	193	R5FSS1_CORE0_INTR_PRU_ICSSM0_PR1_IEP0_CMP_INTR_REQ_15
R5FSS1_CORE0_INTR_IN_194	194	R5FSS1_CORE0_CPSW0_CPTS_COMP
R5FSS1_CORE0_INTR_IN_195	195	R5FSS1_CORE0_GPMC_SINTR
R5FSS1_CORE0_INTR_IN_196	196	R5FSS1_CORE0_ELM_SINTR

10.4.4 R5FSS1_CORE1 Interrupt Map

Table 10-20 shows the mapping of events to the R5FSS1_CORE1.

Both R5FSS1_CORE1 and R5FSS1_CORE0 use the R5FSS1_CORE0 interrupt map when operating in lockstep mode.

Table 10-20. R5FSS1_CORE1 Interrupt Map

Interrupt Input Line	Interrupt ID	Source Interrupt
R5FSS1_CORE1_INTR_IN_0	0	R5FSS1_CORE1_INTR_PRU_ICSSM0_PR1_HOST_INTR_PEND_0
R5FSS1_CORE1_INTR_IN_1	1	R5FSS1_CORE1_INTR_PRU_ICSSM0_PR1_HOST_INTR_PEND_1
R5FSS1_CORE1_INTR_IN_2	2	R5FSS1_CORE1_INTR_PRU_ICSSM0_PR1_HOST_INTR_PEND_2
R5FSS1_CORE1_INTR_IN_3	3	R5FSS1_CORE1_INTR_PRU_ICSSM0_PR1_HOST_INTR_PEND_3
R5FSS1_CORE1_INTR_IN_4	4	R5FSS1_CORE1_INTR_PRU_ICSSM0_PR1_HOST_INTR_PEND_4
R5FSS1_CORE1_INTR_IN_5	5	R5FSS1_CORE1_INTR_PRU_ICSSM0_PR1_HOST_INTR_PEND_5
R5FSS1_CORE1_INTR_IN_6	6	R5FSS1_CORE1_INTR_PRU_ICSSM0_PR1_HOST_INTR_PEND_6
R5FSS1_CORE1_INTR_IN_7	7	R5FSS1_CORE1_INTR_PRU_ICSSM0_PR1_HOST_INTR_PEND_7
R5FSS1_CORE1_INTR_IN_8	8	R5FSS1_CORE1_INTR_PRU_ICSSM0_PR1_RX_SOF_INTR_REQ_0
R5FSS1_CORE1_INTR_IN_9	9	R5FSS1_CORE1_INTR_PRU_ICSSM0_PR1_RX_SOF_INTR_REQ_1
R5FSS1_CORE1_INTR_IN_10	10	R5FSS1_CORE1_INTR_PRU_ICSSM0_PR1_TX_SOF_INTR_REQ_0
R5FSS1_CORE1_INTR_IN_11	11	R5FSS1_CORE1_INTR_PRU_ICSSM0_PR1_TX_SOF_INTR_REQ_1
R5FSS1_CORE1_INTR_IN_12	12	R5FSS1_CORE1_INTR_CPSW0_FH_INTR
R5FSS1_CORE1_INTR_IN_13	13	R5FSS1_CORE1_INTR_CPSW0_TH_INTR
R5FSS1_CORE1_INTR_IN_14	14	R5FSS1_CORE1_INTR_CPSW0_TH_THRESH_INTR
R5FSS1_CORE1_INTR_IN_15	15	R5FSS1_CORE1_INTR_CPSW0_MISC_INTR
R5FSS1_CORE1_INTR_IN_16	16	R5FSS1_CORE1_INTR_LIN0_INTR_0
R5FSS1_CORE1_INTR_IN_17	17	R5FSS1_CORE1_INTR_LIN0_INTR_1
R5FSS1_CORE1_INTR_IN_18	18	R5FSS1_CORE1_INTR_LIN1_INTR_0
R5FSS1_CORE1_INTR_IN_19	19	R5FSS1_CORE1_INTR_LIN1_INTR_1
R5FSS1_CORE1_INTR_IN_20	20	R5FSS1_CORE1_INTR_LIN2_INTR_0
R5FSS1_CORE1_INTR_IN_21	21	R5FSS1_CORE1_INTR_LIN2_INTR_1
R5FSS1_CORE1_INTR_IN_22	22	R5FSS1_CORE1_INTR_LIN3_INTR_0
R5FSS1_CORE1_INTR_IN_23	23	R5FSS1_CORE1_INTR_LIN3_INTR_1

Table 10-20. R5FSS1_CORE1 Interrupt Map (continued)

Interrupt Input Line	Interrupt ID	Source Interrupt
R5FSS1_CORE1_INTR_IN_24	24	R5FSS1_CORE1_INTR_LIN4_INTR_0
R5FSS1_CORE1_INTR_IN_25	25	R5FSS1_CORE1_INTR_LIN4_INTR_1
R5FSS1_CORE1_INTR_IN_26	26	R5FSS1_CORE1_INTR_MCAN0_EXT_TS_ROLLOVER_LVL_INT_0
R5FSS1_CORE1_INTR_IN_27	27	R5FSS1_CORE1_INTR_MCAN0_MCAN_LVL_INT_0
R5FSS1_CORE1_INTR_IN_28	28	R5FSS1_CORE1_INTR_MCAN0_MCAN_LVL_INT_1
R5FSS1_CORE1_INTR_IN_29	29	R5FSS1_CORE1_INTR_MCAN1_EXT_TS_ROLLOVER_LVL_INT_0
R5FSS1_CORE1_INTR_IN_30	30	R5FSS1_CORE1_INTR_MCAN1_MCAN_LVL_INT_0
R5FSS1_CORE1_INTR_IN_31	31	R5FSS1_CORE1_INTR_MCAN1_MCAN_LVL_INT_1
R5FSS1_CORE1_INTR_IN_32	32	R5FSS1_CORE1_INTR_MCAN2_EXT_TS_ROLLOVER_LVL_INT_0
R5FSS1_CORE1_INTR_IN_33	33	R5FSS1_CORE1_INTR_MCAN2_MCAN_LVL_INT_0
R5FSS1_CORE1_INTR_IN_34	34	R5FSS1_CORE1_INTR_MCAN2_MCAN_LVL_INT_1
R5FSS1_CORE1_INTR_IN_35	35	R5FSS1_CORE1_INTR_MCAN3_EXT_TS_ROLLOVER_LVL_INT_0
R5FSS1_CORE1_INTR_IN_36	36	R5FSS1_CORE1_INTR_MCAN3_MCAN_LVL_INT_0
R5FSS1_CORE1_INTR_IN_37	37	R5FSS1_CORE1_INTR_MCAN3_MCAN_LVL_INT_1
R5FSS1_CORE1_INTR_IN_38	38	R5FSS1_CORE1_INTR_UART0_IRQ
R5FSS1_CORE1_INTR_IN_39	39	R5FSS1_CORE1_INTR_UART1_IRQ
R5FSS1_CORE1_INTR_IN_40	40	R5FSS1_CORE1_INTR_UART2_IRQ
R5FSS1_CORE1_INTR_IN_41	41	R5FSS1_CORE1_INTR_UART3_IRQ
R5FSS1_CORE1_INTR_IN_42	42	R5FSS1_CORE1_INTR_UART4_IRQ
R5FSS1_CORE1_INTR_IN_43	43	R5FSS1_CORE1_INTR_UART5_IRQ
R5FSS1_CORE1_INTR_IN_44	44	R5FSS1_CORE1_INTR_I2C0_IRQ
R5FSS1_CORE1_INTR_IN_45	45	R5FSS1_CORE1_INTR_I2C1_IRQ
R5FSS1_CORE1_INTR_IN_46	46	R5FSS1_CORE1_INTR_I2C2_IRQ
R5FSS1_CORE1_INTR_IN_47	47	R5FSS1_CORE1_INTR_I2C3_IRQ
R5FSS1_CORE1_INTR_IN_48	48	R5FSS1_CORE1_INTR_DTHE_SHA_S_INT
R5FSS1_CORE1_INTR_IN_49	49	R5FSS1_CORE1_INTR_DTHE_SHA_P_INT
R5FSS1_CORE1_INTR_IN_50	50	R5FSS1_CORE1_INTR_DTHE_TRNG_INT

Table 10-20. R5FSS1_CORE1 Interrupt Map (continued)

Interrupt Input Line	Interrupt ID	Source Interrupt
R5FSS1_CORE1_INTR_IN_51	51	R5FSS1_CORE1_INTR_DTHE_PKAE_INT
R5FSS1_CORE1_INTR_IN_52	52	R5FSS1_CORE1_INTR_DTHE_AES_S_INT
R5FSS1_CORE1_INTR_IN_53	53	R5FSS1_CORE1_INTR_DTHE_AES_P_INT
R5FSS1_CORE1_INTR_IN_54	54	R5FSS1_CORE1_INTR_QSPI0_INT
R5FSS1_CORE1_INTR_IN_55	55	R5FSS1_CORE1_INTR_TPCC0_INTG
R5FSS1_CORE1_INTR_IN_56	56	R5FSS1_CORE1_INTR_TPCC0_INT_0
R5FSS1_CORE1_INTR_IN_57	57	R5FSS1_CORE1_INTR_TPCC0_INT_1
R5FSS1_CORE1_INTR_IN_58	58	R5FSS1_CORE1_INTR_TPCC0_INT_2
R5FSS1_CORE1_INTR_IN_59	59	R5FSS1_CORE1_INTR_TPCC0_INT_3
R5FSS1_CORE1_INTR_IN_60	60	R5FSS1_CORE1_INTR_TPCC0_INT_4
R5FSS1_CORE1_INTR_IN_61	61	R5FSS1_CORE1_INTR_TPCC0_INT_5
R5FSS1_CORE1_INTR_IN_62	62	R5FSS1_CORE1_INTR_TPCC0_INT_6
R5FSS1_CORE1_INTR_IN_63	63	R5FSS1_CORE1_INTR_TPCC0_INT_7
R5FSS1_CORE1_INTR_IN_64	64	R5FSS1_CORE1_INTR_TPCC0_ERRINT
R5FSS1_CORE1_INTR_IN_65	65	R5FSS1_CORE1_INTR_TPCC0_MPINT
R5FSS1_CORE1_INTR_IN_66	66	R5FSS1_CORE1_INTR_TPTC0_ERINT_0
R5FSS1_CORE1_INTR_IN_67	67	R5FSS1_CORE1_INTR_TPTC0_ERINT_1
R5FSS1_CORE1_INTR_IN_68	68	R5FSS1_CORE1_INTR_MCRC0_INT
R5FSS1_CORE1_INTR_IN_69	69	R5FSS1_CORE1_INTR_MPU_ADDR_ERRAGG
R5FSS1_CORE1_INTR_IN_70	70	R5FSS1_CORE1_INTR_MPU_PROT_ERRAGG
R5FSS1_CORE1_INTR_IN_71	71	R5FSS1_CORE1_INTR_PBIST_DONE
R5FSS1_CORE1_INTR_IN_72	72	R5FSS1_CORE1_INTR_TPCC0_INTAGGR
R5FSS1_CORE1_INTR_IN_73	73	R5FSS1_CORE1_INTR_TPCC0_ERRAGGR
R5FSS1_CORE1_INTR_IN_74	74	R5FSS1_CORE1_INTR_DCC0_DONE
R5FSS1_CORE1_INTR_IN_75	75	R5FSS1_CORE1_INTR_DCC1_DONE
R5FSS1_CORE1_INTR_IN_76	76	R5FSS1_CORE1_INTR_DCC2_DONE
R5FSS1_CORE1_INTR_IN_77	77	R5FSS1_CORE1_INTR_DCC3_DONE

Table 10-20. R5FSS1_CORE1 Interrupt Map (continued)

Interrupt Input Line	Interrupt ID	Source Interrupt
R5FSS1_CORE1_INTR_IN_78	78	R5FSS1_CORE1_INTR_MCSPi0_INTR
R5FSS1_CORE1_INTR_IN_79	79	R5FSS1_CORE1_INTR_MCSPi1_INTR
R5FSS1_CORE1_INTR_IN_80	80	R5FSS1_CORE1_INTR_MCSPi2_INTR
R5FSS1_CORE1_INTR_IN_81	81	R5FSS1_CORE1_INTR_MCSPi3_INTR
R5FSS1_CORE1_INTR_IN_82	82	R5FSS1_CORE1_INTR_MCSPi4_INTR
R5FSS1_CORE1_INTR_IN_83	83	R5FSS1_CORE1_INTR_MMC0_INTR
R5FSS1_CORE1_INTR_IN_84	84	R5FSS1_CORE1_INTR_RTIO_INTR_0
R5FSS1_CORE1_INTR_IN_85	85	R5FSS1_CORE1_INTR_RTIO_INTR_1
R5FSS1_CORE1_INTR_IN_86	86	R5FSS1_CORE1_INTR_RTIO_INTR_2
R5FSS1_CORE1_INTR_IN_87	87	R5FSS1_CORE1_INTR_RTIO_INTR_3
R5FSS1_CORE1_INTR_IN_88	88	R5FSS1_CORE1_INTR_RESERVED88
R5FSS1_CORE1_INTR_IN_89	89	R5FSS1_CORE1_INTR_RTIO_OVERFLOW_INT0
R5FSS1_CORE1_INTR_IN_90	90	R5FSS1_CORE1_INTR_RTIO_OVERFLOW_INT1
R5FSS1_CORE1_INTR_IN_91	91	R5FSS1_CORE1_INTR_RT11_INTR_0
R5FSS1_CORE1_INTR_IN_92	92	R5FSS1_CORE1_INTR_RT11_INTR_1
R5FSS1_CORE1_INTR_IN_93	93	R5FSS1_CORE1_INTR_RT11_INTR_2
R5FSS1_CORE1_INTR_IN_94	94	R5FSS1_CORE1_INTR_RT11_INTR_3
R5FSS1_CORE1_INTR_IN_95	95	R5FSS1_CORE1_INTR_RESERVED95
R5FSS1_CORE1_INTR_IN_96	96	R5FSS1_CORE1_INTR_RT11_OVERFLOW_INT0
R5FSS1_CORE1_INTR_IN_97	97	R5FSS1_CORE1_INTR_RT11_OVERFLOW_INT1
R5FSS1_CORE1_INTR_IN_98	98	R5FSS1_CORE1_INTR_RT12_INTR_0
R5FSS1_CORE1_INTR_IN_99	99	R5FSS1_CORE1_INTR_RT12_INTR_1
R5FSS1_CORE1_INTR_IN_100	100	R5FSS1_CORE1_INTR_RT12_INTR_2
R5FSS1_CORE1_INTR_IN_101	101	R5FSS1_CORE1_INTR_RT12_INTR_3
R5FSS1_CORE1_INTR_IN_102	102	R5FSS1_CORE1_INTR_RESERVED102
R5FSS1_CORE1_INTR_IN_103	103	R5FSS1_CORE1_INTR_RT12_OVERFLOW_INT0
R5FSS1_CORE1_INTR_IN_104	104	R5FSS1_CORE1_INTR_RT12_OVERFLOW_INT1

Table 10-20. R5FSS1_CORE1 Interrupt Map (continued)

Interrupt Input Line	Interrupt ID	Source Interrupt
R5FSS1_CORE1_INTR_IN_105	105	R5FSS1_CORE1_INTR_RTI3_INTR_0
R5FSS1_CORE1_INTR_IN_106	106	R5FSS1_CORE1_INTR_RTI3_INTR_1
R5FSS1_CORE1_INTR_IN_107	107	R5FSS1_CORE1_INTR_RTI3_INTR_2
R5FSS1_CORE1_INTR_IN_108	108	R5FSS1_CORE1_INTR_RTI3_INTR_3
R5FSS1_CORE1_INTR_IN_109	109	R5FSS1_CORE1_INTR_RESERVED109
R5FSS1_CORE1_INTR_IN_110	110	R5FSS1_CORE1_INTR_RTI3_OVERFLOW_INT0
R5FSS1_CORE1_INTR_IN_111	111	R5FSS1_CORE1_INTR_RTI3_OVERFLOW_INT1
R5FSS1_CORE1_INTR_IN_112	112	R5FSS1_CORE1_INTR_RESERVED112
R5FSS1_CORE1_INTR_IN_113	113	R5FSS1_CORE1_INTR_ESM0_ESM_INT_CFG
R5FSS1_CORE1_INTR_IN_114	114	R5FSS1_CORE1_INTR_ESM0_ESM_INT_HI
R5FSS1_CORE1_INTR_IN_115	115	R5FSS1_CORE1_INTR_ESM0_ESM_INT_LOW
R5FSS1_CORE1_INTR_IN_116	116	R5FSS1_CORE1_INTR_R5SS0_CPU0_PMU_INT
R5FSS1_CORE1_INTR_IN_117	117	R5FSS1_CORE1_INTR_R5SS0_CPU1_PMU_INT
R5FSS1_CORE1_INTR_IN_118	118	R5FSS1_CORE1_INTR_R5SS1_COMMRX_1
R5FSS1_CORE1_INTR_IN_119	119	R5FSS1_CORE1_INTR_R5SS1_COMMTX_1
R5FSS1_CORE1_INTR_IN_120	120	R5FSS1_CORE1_INTR_R5SS1_CPU0_CTI_INT
R5FSS1_CORE1_INTR_IN_121	121	R5FSS1_CORE1_INTR_R5SS1_CPU1_CTI_INT
R5FSS1_CORE1_INTR_IN_122	122	R5FSS1_CORE1_INTR_R5SS1_CPU1_VALFIQ
R5FSS1_CORE1_INTR_IN_123	123	R5FSS1_CORE1_INTR_R5SS1_CPU1_VALIRQ
R5FSS1_CORE1_INTR_IN_124	124	R5FSS1_CORE1_INTR_MMR_ACC_ERRAGG
R5FSS1_CORE1_INTR_IN_125	125	R5FSS1_CORE1_INTR_R5SS1_LIVELOCK_0
R5FSS1_CORE1_INTR_IN_126	126	R5FSS1_CORE1_INTR_R5SS0_LIVELOCK_0
R5FSS1_CORE1_INTR_IN_127	127	R5FSS1_CORE1_INTR_R5SS0_LIVELOCK_1
R5FSS1_CORE1_INTR_IN_128	128	R5FSS1_CORE1_INTR_RTI_WDT3_NMI
R5FSS1_CORE1_INTR_IN_129	129	R5FSS1_CORE1_INTR_SW_IRQ
R5FSS1_CORE1_INTR_IN_130	130	R5FSS1_CORE1_INTR_R5SS1_CORE1_FPU_EXP
R5FSS1_CORE1_INTR_IN_131	131	R5FSS1_CORE1_INTR_DEBUGSS_TXDATA_AVAIL

Table 10-20. R5FSS1_CORE1 Interrupt Map (continued)

Interrupt Input Line	Interrupt ID	Source Interrupt
R5FSS1_CORE1_INTR_IN_132	132	R5FSS1_CORE1_INTR_DEBUGSS_R5SS0_STC_DONE
R5FSS1_CORE1_INTR_IN_133	133	R5FSS1_CORE1_INTR_TSENSE_H
R5FSS1_CORE1_INTR_IN_134	134	R5FSS1_CORE1_INTR_TSENSE_L
R5FSS1_CORE1_INTR_IN_135	135	R5FSS1_CORE1_INTR_AHB_WRITE_ERR
R5FSS1_CORE1_INTR_IN_136	136	R5FSS1_CORE1_INTR_MBOX_READ_REQ
R5FSS1_CORE1_INTR_IN_137	137	R5FSS1_CORE1_INTR_MBOX_READ_ACK
R5FSS1_CORE1_INTR_IN_138	138	R5FSS1_CORE1_INTR_SOC_TIMESYNXBAR1_OUT_30
R5FSS1_CORE1_INTR_IN_139	139	R5FSS1_CORE1_INTR_SOC_TIMESYNXBAR1_OUT_31
R5FSS1_CORE1_INTR_IN_140	140	R5FSS1_CORE1_INTR_SOC_TIMESYNXBAR1_OUT_32
R5FSS1_CORE1_INTR_IN_141	141	R5FSS1_CORE1_INTR_SOC_TIMESYNXBAR1_OUT_33
R5FSS1_CORE1_INTR_IN_142	142	R5FSS1_CORE1_INTR_GPIO_INTRXBAR_OUT_26
R5FSS1_CORE1_INTR_IN_143	143	R5FSS1_CORE1_INTR_GPIO_INTRXBAR_OUT_27
R5FSS1_CORE1_INTR_IN_144	144	R5FSS1_CORE1_INTR_GPIO_INTRXBAR_OUT_28
R5FSS1_CORE1_INTR_IN_145	145	R5FSS1_CORE1_INTR_GPIO_INTRXBAR_OUT_29
R5FSS1_CORE1_INTR_IN_146	146	R5FSS1_CORE1_CONTROLSS_INTRXBAR0_OUT_0
R5FSS1_CORE1_INTR_IN_147	147	R5FSS1_CORE1_CONTROLSS_INTRXBAR0_OUT_1
R5FSS1_CORE1_INTR_IN_148	148	R5FSS1_CORE1_CONTROLSS_INTRXBAR0_OUT_2
R5FSS1_CORE1_INTR_IN_149	149	R5FSS1_CORE1_CONTROLSS_INTRXBAR0_OUT_3
R5FSS1_CORE1_INTR_IN_150	150	R5FSS1_CORE1_CONTROLSS_INTRXBAR0_OUT_4
R5FSS1_CORE1_INTR_IN_151	151	R5FSS1_CORE1_CONTROLSS_INTRXBAR0_OUT_5
R5FSS1_CORE1_INTR_IN_152	152	R5FSS1_CORE1_CONTROLSS_INTRXBAR0_OUT_6
R5FSS1_CORE1_INTR_IN_153	153	R5FSS1_CORE1_CONTROLSS_INTRXBAR0_OUT_7
R5FSS1_CORE1_INTR_IN_154	154	R5FSS1_CORE1_CONTROLSS_INTRXBAR0_OUT_8
R5FSS1_CORE1_INTR_IN_155	155	R5FSS1_CORE1_CONTROLSS_INTRXBAR0_OUT_9
R5FSS1_CORE1_INTR_IN_156	156	R5FSS1_CORE1_CONTROLSS_INTRXBAR0_OUT_10
R5FSS1_CORE1_INTR_IN_157	157	R5FSS1_CORE1_CONTROLSS_INTRXBAR0_OUT_11
R5FSS1_CORE1_INTR_IN_158	158	R5FSS1_CORE1_CONTROLSS_INTRXBAR0_OUT_12

Table 10-20. R5FSS1_CORE1 Interrupt Map (continued)

Interrupt Input Line	Interrupt ID	Source Interrupt
R5FSS1_CORE1_INTR_IN_159	159	R5FSS1_CORE1_CONTROLSS_INTRXBAR0_OUT_13
R5FSS1_CORE1_INTR_IN_160	160	R5FSS1_CORE1_CONTROLSS_INTRXBAR0_OUT_14
R5FSS1_CORE1_INTR_IN_161	161	R5FSS1_CORE1_CONTROLSS_INTRXBAR0_OUT_15
R5FSS1_CORE1_INTR_IN_162	162	R5FSS1_CORE1_CONTROLSS_INTRXBAR0_OUT_16
R5FSS1_CORE1_INTR_IN_163	163	R5FSS1_CORE1_CONTROLSS_INTRXBAR0_OUT_17
R5FSS1_CORE1_INTR_IN_164	164	R5FSS1_CORE1_CONTROLSS_INTRXBAR0_OUT_18
R5FSS1_CORE1_INTR_IN_165	165	R5FSS1_CORE1_CONTROLSS_INTRXBAR0_OUT_19
R5FSS1_CORE1_INTR_IN_166	166	R5FSS1_CORE1_CONTROLSS_INTRXBAR0_OUT_20
R5FSS1_CORE1_INTR_IN_167	167	R5FSS1_CORE1_CONTROLSS_INTRXBAR0_OUT_21
R5FSS1_CORE1_INTR_IN_168	168	R5FSS1_CORE1_CONTROLSS_INTRXBAR0_OUT_22
R5FSS1_CORE1_INTR_IN_169	169	R5FSS1_CORE1_CONTROLSS_INTRXBAR0_OUT_23
R5FSS1_CORE1_INTR_IN_170	170	R5FSS1_CORE1_CONTROLSS_INTRXBAR0_OUT_24
R5FSS1_CORE1_INTR_IN_171	171	R5FSS1_CORE1_CONTROLSS_INTRXBAR0_OUT_25
R5FSS1_CORE1_INTR_IN_172	172	R5FSS1_CORE1_CONTROLSS_INTRXBAR0_OUT_26
R5FSS1_CORE1_INTR_IN_173	173	R5FSS1_CORE1_CONTROLSS_INTRXBAR0_OUT_27
R5FSS1_CORE1_INTR_IN_174	174	R5FSS1_CORE1_CONTROLSS_INTRXBAR0_OUT_28
R5FSS1_CORE1_INTR_IN_175	175	R5FSS1_CORE1_CONTROLSS_INTRXBAR0_OUT_29
R5FSS1_CORE1_INTR_IN_176	176	R5FSS1_CORE1_CONTROLSS_INTRXBAR0_OUT_30
R5FSS1_CORE1_INTR_IN_177	177	R5FSS1_CORE1_CONTROLSS_INTRXBAR0_OUT_31
R5FSS1_CORE1_INTR_IN_178	178	R5FSS1_CORE1_INTR_PRU_ICSSM0_PR1_IEP0_CMP_INTR_REQ_0
R5FSS1_CORE1_INTR_IN_179	179	R5FSS1_CORE1_INTR_PRU_ICSSM0_PR1_IEP0_CMP_INTR_REQ_1
R5FSS1_CORE1_INTR_IN_180	180	R5FSS1_CORE1_INTR_PRU_ICSSM0_PR1_IEP0_CMP_INTR_REQ_2
R5FSS1_CORE1_INTR_IN_181	181	R5FSS1_CORE1_INTR_PRU_ICSSM0_PR1_IEP0_CMP_INTR_REQ_3
R5FSS1_CORE1_INTR_IN_182	182	R5FSS1_CORE1_INTR_PRU_ICSSM0_PR1_IEP0_CMP_INTR_REQ_4
R5FSS1_CORE1_INTR_IN_183	183	R5FSS1_CORE1_INTR_PRU_ICSSM0_PR1_IEP0_CMP_INTR_REQ_5
R5FSS1_CORE1_INTR_IN_184	184	R5FSS1_CORE1_INTR_PRU_ICSSM0_PR1_IEP0_CMP_INTR_REQ_6
R5FSS1_CORE1_INTR_IN_185	185	R5FSS1_CORE1_INTR_PRU_ICSSM0_PR1_IEP0_CMP_INTR_REQ_7

Table 10-20. R5FSS1_CORE1 Interrupt Map (continued)

Interrupt Input Line	Interrupt ID	Source Interrupt
R5FSS1_CORE1_INTR_IN_186	186	R5FSS1_CORE1_INTR_PRU_ICSSM0_PR1_IEP0_CMP_INTR_REQ_8
R5FSS1_CORE1_INTR_IN_187	187	R5FSS1_CORE1_INTR_PRU_ICSSM0_PR1_IEP0_CMP_INTR_REQ_9
R5FSS1_CORE1_INTR_IN_188	188	R5FSS1_CORE1_INTR_PRU_ICSSM0_PR1_IEP0_CMP_INTR_REQ_10
R5FSS1_CORE1_INTR_IN_189	189	R5FSS1_CORE1_INTR_PRU_ICSSM0_PR1_IEP0_CMP_INTR_REQ_11
R5FSS1_CORE1_INTR_IN_190	190	R5FSS1_CORE1_INTR_PRU_ICSSM0_PR1_IEP0_CMP_INTR_REQ_12
R5FSS1_CORE1_INTR_IN_191	191	R5FSS1_CORE1_INTR_PRU_ICSSM0_PR1_IEP0_CMP_INTR_REQ_13
R5FSS1_CORE1_INTR_IN_192	192	R5FSS1_CORE1_INTR_PRU_ICSSM0_PR1_IEP0_CMP_INTR_REQ_14
R5FSS1_CORE1_INTR_IN_193	193	R5FSS1_CORE1_INTR_PRU_ICSSM0_PR1_IEP0_CMP_INTR_REQ_15
R5FSS1_CORE1_INTR_IN_194	194	R5FSS1_CORE1_CPSW0_CPTS_COMP
R5FSS1_CORE1_INTR_IN_195	195	R5FSS1_CORE1_GPMC_SINTR
R5FSS1_CORE1_INTR_IN_196	196	R5FSS1_CORE1_ELM_SINTR

10.4.5 PRU_ICSSM0 Interrupt Map

Table 10-21 shows the mapping of events to the PRU_ICSSM0.

Table 10-21. PRU_ICSSM0 Interrupt Map

Interrupt Input Line	Interrupt ID	Interrupt Source	Interrupt Signal
PRU_ICSSM0_INTR_IN_0	0	LIN0	lin0_intr_req0
PRU_ICSSM0_INTR_IN_1	1	LIN0	lin0_intr_req1
PRU_ICSSM0_INTR_IN_2	2	LIN1	lin1_intr_req0
PRU_ICSSM0_INTR_IN_3	3	LIN1	lin1_intr_req1
PRU_ICSSM0_INTR_IN_4	4	LIN2	lin2_intr_req0
PRU_ICSSM0_INTR_IN_5	5	LIN2	lin2_intr_req1
PRU_ICSSM0_INTR_IN_6	6	LIN3	lin3_intr_req0
PRU_ICSSM0_INTR_IN_7	7	LIN3	lin3_intr_req1
PRU_ICSSM0_INTR_IN_8	8	LIN4	lin4_intr_req0
PRU_ICSSM0_INTR_IN_9	9	LIN4	lin4_intr_req1
PRU_ICSSM0_INTR_IN_10	10	UART0	usart0_irq
PRU_ICSSM0_INTR_IN_11	11	UART1	usart1_irq
PRU_ICSSM0_INTR_IN_12	12	UART2	usart2_irq
PRU_ICSSM0_INTR_IN_13	13	UART3	usart3_irq
PRU_ICSSM0_INTR_IN_14	14	UART4	usart4_irq
PRU_ICSSM0_INTR_IN_15	15	UART5	usart5_irq
PRU_ICSSM0_INTR_IN_16	16	I2C0	I2C0_IRQ
PRU_ICSSM0_INTR_IN_17	17	I2C1	I2C1_IRQ
PRU_ICSSM0_INTR_IN_18	18	I2C2	I2C2_IRQ
PRU_ICSSM0_INTR_IN_19	19	I2C3	I2C3_IRQ
PRU_ICSSM0_INTR_IN_20	20	SPI0	spi0_intr

Table 10-21. PRU_ICSSM0 Interrupt Map (continued)

Interrupt Input Line	Interrupt ID	Interrupt Source	Interrupt Signal
PRU_ICSSM0_INTR_IN_21	21	SPI1	spi1_intr
PRU_ICSSM0_INTR_IN_22	22	SPI2	spi2_intr
PRU_ICSSM0_INTR_IN_23	23	SPI3	spi3_intr
PRU_ICSSM0_INTR_IN_24	24	SPI4	spi4_intr
PRU_ICSSM0_INTR_IN_25	25	QSPI	qspi_intr
PRU_ICSSM0_INTR_IN_26	26	EDMA0	TPCC_intg
PRU_ICSSM0_INTR_IN_27	27	EDMA0	TPCC_int0
PRU_ICSSM0_INTR_IN_28	28	EDMA0	TPCC_int1
PRU_ICSSM0_INTR_IN_29	29	EDMA0	TPCC_int2
PRU_ICSSM0_INTR_IN_30	30	EDMA0	TPCC_int3
PRU_ICSSM0_INTR_IN_31	31	EDMA0	TPCC_int4
PRU_ICSSM0_INTR_IN_32	32	EDMA0	TPCC_int5
PRU_ICSSM0_INTR_IN_33	33	EDMA0	TPCC_int6
PRU_ICSSM0_INTR_IN_34	34	EDMA0	TPCC_int7
PRU_ICSSM0_INTR_IN_35	35	EDMA0	TPCC_errint
PRU_ICSSM0_INTR_IN_36	36	EDMA0	tpcc_mpint
PRU_ICSSM0_INTR_IN_37	37	EDMA0	tptc_erint_0
PRU_ICSSM0_INTR_IN_38	38	EDMA0	tptc_erint_1

10.4.6 ESM0 Interrupt Map

Table 10-22 shows the mapping of events to the ESM0.

Table 10-22. ESM0 Interrupt Map

Interrupt Input Line	Interrupt ID	Interrupt Source	Interrupt Signal
Level Events			
ESM_LVL_EVENT_0	0	EFUSE	efc_error
ESM_LVL_EVENT_1	1	EFUSE	efs_autoload_error
ESM_LVL_EVENT_2	2	MCAN0	MCAN0_ecc_corr_lvl_int
ESM_LVL_EVENT_3	3	MCAN0	MCAN0_ecc_uncorr_lvl_int
ESM_LVL_EVENT_4	4	MCAN1	MCAN1_ecc_corr_lvl_int
ESM_LVL_EVENT_5	5	MCAN1	MCAN1_ecc_uncorr_lvl_int
ESM_LVL_EVENT_6	6	MCAN2	MCAN2_ecc_corr_lvl_int
ESM_LVL_EVENT_7	7	MCAN2	MCAN2_ecc_uncorr_lvl_int
ESM_LVL_EVENT_8	8	MCAN3	MCAN3_ecc_corr_lvl_int
ESM_LVL_EVENT_9	9	MCAN3	MCAN3_ecc_uncorr_lvl_int
ESM_LVL_EVENT_10	10	R5FSS0_CORE0	R5FSS0_livelock_0
ESM_LVL_EVENT_11	11	R5FSS0_CORE1	R5FSS0_livelock_1
ESM_LVL_EVENT_12	12	R5FSS1_CORE0	R5FSS1_livelock_0
ESM_LVL_EVENT_13	13	R5FSS1_CORE1	R5FSS1_livelock_1
ESM_LVL_EVENT_14	14	R5FSS0_CORE0	R5FSS0_CORE0_TCMADDR_err
ESM_LVL_EVENT_15	15	R5FSS0_CORE1	R5FSS0_CORE1_TCMADDR_err
ESM_LVL_EVENT_16	16	R5FSS1_CORE0	R5FSS1_CORE0_TCMADDR_err
ESM_LVL_EVENT_17	17	R5FSS1_CORE1	R5FSS1_CORE1_TCMADDR_err
ESM_LVL_EVENT_18	18	Reserved	Reserved
ESM_LVL_EVENT_19	19	ECC_AGGREGATOR	soc_eccagg_corr_level
ESM_LVL_EVENT_20	20	ECC_AGGREGATOR	soc_eccagg_uncorr_level
ESM_LVL_EVENT_21	21	DCC0	DCC0_err
ESM_LVL_EVENT_22	22	DCC1	DCC1_err
ESM_LVL_EVENT_23	23	DCC2	DCC2_err
ESM_LVL_EVENT_24	24	DCC3	DCC3_err
ESM_LVL_EVENT_25	25	CORE_PLL	pll_core_lockloss
ESM_LVL_EVENT_26	26	PERI_PLL	pll_per_lockloss
ESM_LVL_EVENT_27	27	RCOSC	rcref_clk_loss_detect
ESM_LVL_EVENT_28	28	HSM	HSM_ESM_high_intr
ESM_LVL_EVENT_29	29	HSM	HSM_ESM_low_intr
ESM_LVL_EVENT_30	30	XTAL	crystal_clockloss
ESM_LVL_EVENT_31	31	Aggregated VBUSP Error	Aggregated_VBUSP_error_H
ESM_LVL_EVENT_32	32	Reserved	Reserved
ESM_LVL_EVENT_33	33	Aggregated VBUSM Rerror	Aggregated_VBUSM_error_H
ESM_LVL_EVENT_34	34	Aggregated VBUSM Rerror	Aggregated_VBUSM_error_L
ESM_LVL_EVENT_35	35	Reserved	Reserved
ESM_LVL_EVENT_36	36	Reserved	Reserved
ESM_LVL_EVENT_37	37	Reserved	Reserved
ESM_LVL_EVENT_38	38	Reserved	Reserved
ESM_LVL_EVENT_39	39	Reserved	Reserved
ESM_LVL_EVENT_40	40	Reserved	Reserved

Table 10-22. ESM0 Interrupt Map (continued)

Interrupt Input Line	Interrupt ID	Interrupt Source	Interrupt Signal
ESM_LVL_EVENT_41	41	VMON	voltage_monitor_err_H
ESM_LVL_EVENT_42	42	VMON	voltage_monitor_err_L
ESM_LVL_EVENT_43	43	Reserved	Reserved
ESM_LVL_EVENT_44	44	THERMAL_MONITOR	thermal_monitor_critical
ESM_LVL_EVENT_45	45	CPSW3G	CPSW_ECC_SEC_PEND_INTR
ESM_LVL_EVENT_46	46	CPSW3G	CPSW_ECC_DED_PEND_INTR
ESM_LVL_EVENT_47	47	R5FSS0_CORE0	R5FSS0_CORE0_ecc_corrected_level.0
ESM_LVL_EVENT_48	48	R5FSS0_CORE0	R5FSS0_CORE0_ecc_uncorrected_level.0
ESM_LVL_EVENT_49	49	R5FSS0_CORE1	R5FSS0_CORE1_ecc_corrected_level.0
ESM_LVL_EVENT_50	50	R5FSS0_CORE1	R5FSS0_CORE1_ecc_uncorrected_level.0
ESM_LVL_EVENT_51	51	R5FSS0_CORE0	R5FSS0_ecc_de_to_esm_0.0
ESM_LVL_EVENT_52	52	R5FSS0_CORE1	R5FSS0_ecc_de_to_esm_1.0
ESM_LVL_EVENT_53	53	R5FSS0_CORE0	R5FSS0_ecc_se_to_esm_0.0
ESM_LVL_EVENT_54	54	R5FSS0_CORE1	R5FSS0_ecc_se_to_esm_1.0
ESM_LVL_EVENT_55	55	R5FSS1_CORE0	R5FSS1_CORE0_ecc_corrected_level.0
ESM_LVL_EVENT_56	56	R5FSS1_CORE0	R5FSS1_CORE0_ecc_uncorrected_level.0
ESM_LVL_EVENT_57	57	R5FSS1_CORE1	R5FSS1_CORE1_ecc_corrected_level.0
ESM_LVL_EVENT_58	58	R5FSS1_CORE1	R5FSS1_CORE1_ecc_uncorrected_level.0
ESM_LVL_EVENT_59	59	R5FSS0_CORE0	R5FSS1_ecc_de_to_esm_0.0
ESM_LVL_EVENT_60	60	R5FSS0_CORE1	R5FSS1_ecc_de_to_esm_1.0
ESM_LVL_EVENT_61	61	R5FSS0_CORE0	R5FSS1_ecc_se_to_esm_0.0
ESM_LVL_EVENT_62	62	R5FSS0_CORE1	R5FSS1_ecc_se_to_esm_1.0
Pulse Events			
Interrupt Input Line	Interrupt ID	Interrupt Source	Interrupt Signal
ESM_PLS_EVENT_0	0	WWDT0	RTI0_WWD_NMI
ESM_PLS_EVENT_1	1	WWDT1	RTI1_WWD_NMI
ESM_PLS_EVENT_2	2	WWDT2	RTI2_WWD_NMI
ESM_PLS_EVENT_3	3	WWDT3	RTI3_WWD_NMI
ESM_PLS_EVENT_4	4	EDMA0	TPCC_errint
ESM_PLS_EVENT_5	5	R5FSS0	R5FSS0_bus_monitor_err_pulse.0
ESM_PLS_EVENT_6	6	R5FSS0	R5FSS0_compare_err_pulse.0
ESM_PLS_EVENT_7	7	R5FSS0	R5FSS0_vim_compare_err_pulse.0
ESM_PLS_EVENT_8	8	R5FSS0	R5FSS0_cpu_miscompare_pulse.0
ESM_PLS_EVENT_9	9	R5FSS1	R5FSS1_bus_monitor_err_pulse.0
ESM_PLS_EVENT_10	10	R5FSS1	R5FSS1_compare_err_pulse.0
ESM_PLS_EVENT_11	11	R5FSS1	R5FSS1_vim_compare_err_pulse.0
ESM_PLS_EVENT_12	12	R5FSS1	R5FSS1_cpu_miscompare_pulse.0
ESM_PLS_EVENT_13	13	PRU_ICSSM0	pr1_ecc_ded_err_req
ESM_PLS_EVENT_14	14	PRU_ICSSM0	pr1_ecc_sec_err_req
ESM_PLS_EVENT_15	15	SRAM Bank 0	sram0_ecc_uncorr_pulse
ESM_PLS_EVENT_16	16	SRAM Bank 1	sram1_ecc_uncorr_pulse
ESM_PLS_EVENT_17	17	SRAM Bank 2	sram2_ecc_uncorr_pulse
ESM_PLS_EVENT_18	18	SRAM Bank 3	sram3_ecc_uncorr_pulse
ESM_PLS_EVENT_19	19	CCM0	CCM_0_selftest_err
ESM_PLS_EVENT_20	20	CCM0	CCM_0_lockstep_compare_err

Table 10-22. ESM0 Interrupt Map (continued)

Interrupt Input Line	Interrupt ID	Interrupt Source	Interrupt Signal
ESM_PLS_EVENT_21	21	CCM1	CCM_1_selftest_err

This page intentionally left blank.

Chapter 11
Data Movement Architecture



This chapter describes the data movement architecture of the device.

.....800

Note

This content is currently **under-construction** and subject to change prior to official device release.

ADVANCE INFORMATION

11.1 Data Movement Architecture Overview

This chapter is a high-level summary of the data movement architecture implemented in the device.

11.1.1 Overview	802
11.1.2 Definition of Terms	802

11.1.1 Overview

The primary goal of the device Data Movement Architecture and related Subsystems is to ensure that data can be efficiently transferred from a producer to a consumer while meeting the real time requirements of the system.

The Enhanced Data Movement Architecture (EDMA) module aims to facilitate direct memory access (DMA) and provides a consistent Application Programming Interface (API) to the host software.

Data movement tasks are commonly offloaded from the host processor to peripheral hardware to increase system performance. Significant performance gains result from careful design of the interface between the host software and the underlying acceleration hardware. In networking applications, packet transmission and reception are critical tasks. In general purpose compute, ping pong buffer prefetch and store are critical tasks as well as general mis-aligned block copy operations.

The design goals for the device Data Movement Architecture and are as follows:

- Minimize cost
- Minimize host overhead
- Maximize memory use efficiency
- Maximize bus burst efficiency
- Maximize symmetry between transmit/receive operations
- Maximize scalability for number of connections / buffer sizes / queue sizes / protocols supported
- Minimize protocol specific features
- Minimize complexity

This content is under-construction. Note is included as a placeholder for future developments.

11.1.2 Definition of Terms

Channel— A channel refers to the sub-division of information (flows) that is transported across a DMA engine. Each channel has associated state information. Channels are used to segregate information flows based on the protocol used, scheduling requirements (for example, CBR, VBR, ABR), or concurrency requirements (that is, blocking avoidance). Information flow within a channel is a stream of strongly ordered information.

Data Buffer— A data buffer is a single data structure that contains payload information for transmission to or reception from a channel.

Buffer Descriptor— A buffer descriptor is a single data structure that contains information about one or more data buffers.

Packet Descriptor— A packet descriptor is another name for the first buffer descriptor within a packet. Some fields within a data buffer descriptor are only valid when it is a packet descriptor including the tags, packet length, packet type, and flags. All Monolithic type descriptors are packet descriptors (and are also a Data Buffer).

Queue— A queue is a list of strongly ordered entries which is typically used to pass work between a producer and a consumer. Queue entries in most cases are references to a work payload which is being passed but in some cases (Transfer Request Packets for example) queue entries may actually contain data which is being transferred. Queues are used throughout DMA whenever communication is required between entities. Queues can have multiple different implementations and DMA uses two of the most common: linked lists and rings.

Linked list— A linked list is a data structure in which each entry stores not only the entry data but also a chaining pointer to the next entry in the list. The last entry in each list has its chaining pointer set to NULL (typically encoded as 0x0). The list manager maintains a pointer to the head element on the list and to the tail element on the list. Since the chaining pointer is stored with the entry data, linked lists have a length which is dynamically changeable and limited only by the ability to allocate additional entries which are to be queued/de-queued. Linked lists are present in Host Descriptors to chain multiple descriptors to form a packet.

Ring— A ring is a data structure in which a contiguous memory block defined by M N-byte entries (total size is M × N bytes) is statically allocated and sequentially written/read in order to pass data or data references. Rings are also referred to as circular buffers because when the last element in the contiguous memory array is

written, the pointers wrap back to the beginning address for the ring and start the process all over again. The Ring Accelerator component uses rings in order to implement logical queues.

Memory— Memory is an area of data storage managed by the host. This area is visible to the port as a 64-bit addressable area.

Device Driver— A device driver is application independent software that runs on the host for purposes abstracting the low level hardware so that upper level software can use the hardware without knowing every bit field location or initialization sequence.. General device driver functions include port initialization, transmit packet queuing, and receive packet processing.

SOP— Start of Packet. This refers to the descriptor/buffer that is the first buffer in a packet.

MOP— Middle of Packet. This refers to the descriptors/buffers that are neither the first or last buffers in a packet.

EOP— End of Packet. This refers to the descriptor/buffer that is the last buffer in a packet.

11.2 Enhanced Direct Memory Access (EDMA)

This section describes the Enhanced Direct Memory Access (EDMA) controller. For features applicable to the EDMA instances in the device, see the device-specific Integration section. The primary purpose of the EDMA controller is to service data transfers programmed between two memory-mapped follower endpoints on the device. The EDMA controller consists of two principle blocks:

- EDMA channel controllers: EDMA_TPCC
- EDMA transfer controllers: EDMA_TPTC

Devices can have multiple instances of EDMA channel controllers, each associated with multiple EDMA transfer controllers.

The EDMA channel controller serves as the user interface for the EDMA controller. The EDMA_TPCC includes parameter RAM (PaRAM), channel control registers, and interrupt control registers. The EDMA_TPCC serves to prioritize incoming software requests or events from peripherals, and submits transfer requests (TR) to the EDMA transfer controller.

The EDMA transfer controllers are responsible for data movement. The transfer request packets (TRP) submitted by the EDMA_TPCC contain the transfer context, based on which the transfer controller issues read/write commands to the source and destination addresses programmed for a given transfer.

Note

This content is currently **under-construction** and subject to change prior to official device release.

.....	804
11.2.1 EDMA Module Overview	805
11.2.2 EDMA Integration	806
11.2.3 EDMA Controller Functional Description	809
11.2.4 EDMA Transfer Examples	858
11.2.5 EDMA Debug Checklist and Programming Tips	865
11.2.6 EDMA Event Map	867

11.2.1 EDMA Module Overview

The enhanced direct memory access module, also called EDMA, performs high-performance data transfers between two target endpoints, memories and peripheral devices without microprocessor unit (MPU) or digital signal processor (DSP) support during transfer. EDMA transfer is programmed through a logical EDMA channel, which allows the transfer to be optimally tailored to the requirements of the application.

The EDMA controller is based on two major principal blocks:

- EDMA third-party channel controller (EDMA_TPCC)
- EDMA third-party transfer controller (EDMA_TPTC)

Figure 11-1 shows an overview of the EDMA module.

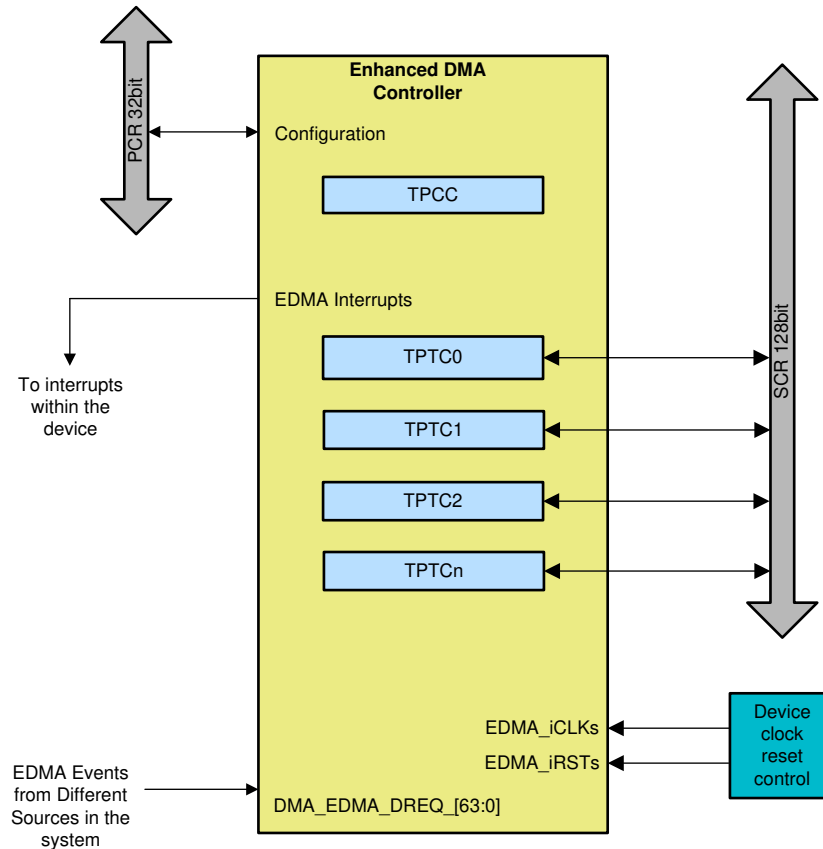

Figure 11-1. EDMA Module Overview

For EDMA instances available on the device, see the device-specific integration section.

The **TPCC** is a high flexible channel controller that serves as both a user interface and an event interface for the EDMA controller. The EDMA_TPCC serves to prioritize incoming software requests or events from peripherals, and submits transfer requests (TRs) to the transfer controller.

The **TPTC** performs read and write transfers by EDMA ports to the target peripherals, as programmed in the Active and Pending set of the registers. The transfer controllers are responsible for data movement, and issue read/write commands to the source and destination addresses programmed for a given transfer in the EDMA_TPCC.

11.2.1.1 EDMA Features

This section shows generic EDMA features. For features applicable to the EDMA instances in the device, see the device-specific Integration section.

The EDMA_TPCC channel controller has the following features:

- Fully orthogonal transfer description:
 - Three transfer dimensions
 - A-synchronized transfers: one dimension serviced per event
 - AB-synchronized transfers: two dimensions serviced per event
 - Independent indexes on source and destination
 - Chaining feature allowing a 3-D transfer based on a single event.
- Flexible transfer definition:
 - Increment or FIFO transfer addressing modes
 - Linking mechanism allows automatic PaRAM set update
 - Chaining allows multiple transfers to execute with one event
- Interrupt generation for the following:
 - Transfer completion
 - Error conditions
- Debug visibility:
 - Queue water marking/threshold
 - Error and status recording to facilitate debug
- 64 DMA request channels:
 - Event synchronization
 - Manual synchronization (CPUs write to event set registers EDMA_TPCC_ESR and EDMA_TPCC_ESRH).
 - Chain synchronization (completion of one transfer triggers another transfer).
- Eight QDMA channels:
 - QDMA channels trigger automatically upon writing to a parameter RAM (PaRAM) set entry.
 - Support for programmable QDMA channel to PaRAM mapping.
- Each PaRAM set can be used for a DMA channel, QDMA channel, or link set.
- Multiple transfer controllers/event queues.
- 16 event entries per event queue.

The **EDMA_TPTC** transfer controller has the following features:

- 128-bit wide read and write ports per TC
- Supports two-dimensional transfers with independent indexes on source and destination (EDMA_TPCC manages the third dimension)
- Support for increment or constant addressing mode transfers
- Interrupt and error support
- Memory-Mapped Register (MMR) bit fields are fixed position in 32-bit MMR regardless of endianness

11.2.2 EDMA Integration

This section describes modules integration in the device, including information about clocks, resets, and hardware requests.

11.2.2.1 EDMA Integration

Note

For more information on the interconnects, see the *System Interconnect* chapter.

For more information on power, reset, and clock management, see the corresponding sections within the *Device Configuration* chapter.

For more information on the device interrupt controllers, see the *Interrupt Controllers* chapter.

11.2.2.2 EDMA Interrupt Aggregator

The following EDMA interrupts are aggregated and sent to the processor:

- TPCC Completion Interrupt
- TPCC Completion Region Interrupts
- TPTCs Completion Interrupt

Table 11-1 shows the associated interrupt and registers for each TPCC instance.

Table 11-1. TPCC Interrupts

TPCC	Interrupt	Registers Space
TPCC0	TPCC0_INTAGG	*_INTAGG_MASK *_INTAGG_STATUS *_INTAGG_STATUS_RAW

For an event to generate an interrupt to the processor, the corresponding bit field must be unmasked in TPCC_x_INTAGG_MASK.

Only an interrupt processor can read the TPCC_x_INTAGG_STATUS register to detect which event triggered the interrupt.

The interrupt can be cleared by writing 0x1 to the corresponding bit in TPCC_x_INTAGG_STATUS.

The software must verify that all the aggregated interrupts are cleared so that the level interrupt is de-asserted before exiting the ISR. Only then the software can provide a new pulse interrupt to the processor. Thus, after clearing the software can read the register to confirm a value of 0x0.

The register TPCC_x_INTAGG_STATUS_RAW is set on an event irrespective of the value in TPCC_x_INTAGG_MASK. This field can be cleared by writing 0x1 to the corresponding bit in TPCC_x_INTAGG_STATUS_RAW.

11.2.2.3 EDMA Error Interrupt Aggregator

The following interrupts are aggregated and sent to the processor:

- TPCC Error
- TPCC MPU Error
- TPTCs Error
- TPCC Read and Write Config Space Access error
- TPTCs Read and Write Config Space Access error

Table 11-2. TPCC Error Interrupt Aggregators

TPCC	Interrupt	Registers Space
TPCC0	TPCC0_ERRAGG	*_ERRAGG_MASK *_ERRAGG_STATUS *_ERRAGG_STATUS_RAW

For an event to generate an interrupt to the processor, the corresponding bit field must be unmasked in TPCC_x_ERRAGG_MASK.

Only an interrupt processor can read the TPCC_x_ERRAGG_STATUS register to detect which event triggered the interrupt.

The interrupt can be cleared by writing 0x1 to the corresponding bit in TPCC_x_ERRAGG_STATUS.

The software must ensure that all the aggregated interrupts are cleared so that the level interrupt is de-asserted before exiting the ISR. Only then is it ensured that a new pulse interrupt is generated to the processor. Thus, after clearing the software should read the register to confirm a value of 0x0

The register TPCC_x_ERRAGG_STATUS_RAW is set on an event irrespective of the value in TPCC_x_ERRAGG_MASK. This field can be cleared by writing 0x1 to the corresponding bit in TPCC_x_ERRAGG_STATUS_RAW.

11.2.2.4 EDMA Configuration

- The device has 1 channel controller: TPCC0 and two transfer controllers: TPTC0 and TPTC1.

Table 11-3. EDMA Channel Controller Configuration

Parameters	TPCC0
DMA Channel	64
Param Entires	128
QDMA Channel	8
Event queues	2
Mem Protection	Yes
Channel Mapping	Yes
Num TCs	2
Num Interrupt Channel	64
Num Regions	8

Table 11-4. EDMA Transfer Controller Configuration

Parameters	TPTC<0/1>
FIFO Size	512
TR Pipe Depth	4
Bus Width	8
Read Cmd Num	8
Write Cmd Num	8
RAM ECC	Yes

Default Burst Size configuration (DBS)

All TPTCs in the device support four different configurable default-burst-sizes. [Table 11-5](#) shows the config-value to DBS mapping.

Table 11-5. Config Value to DBS Mapping

Config value	Burst size
2'b00	16 bytes
2'b01	32 bytes
2'b10	64 bytes
2'b11	128 bytes

Table 11-6. TPTC DBS Configuration Registers

TPTC instance	Corresponding Register
TPTC<0/1>	TPTC_DBS_CONFIG::TPTC_DBS_CONFIG_TPTC<0/1>

11.2.3 EDMA Controller Functional Description

This chapter discusses the architecture of the EDMA controller. The description contained in this section is generic to the EDMA module, and not all features mentioned here are supported by the device. See the EDMA integration section of the device to determine the applicability of these features.

11.2.3.1 Block Diagram

Figure 11-2 shows the functional block diagram of the EDMA controller.

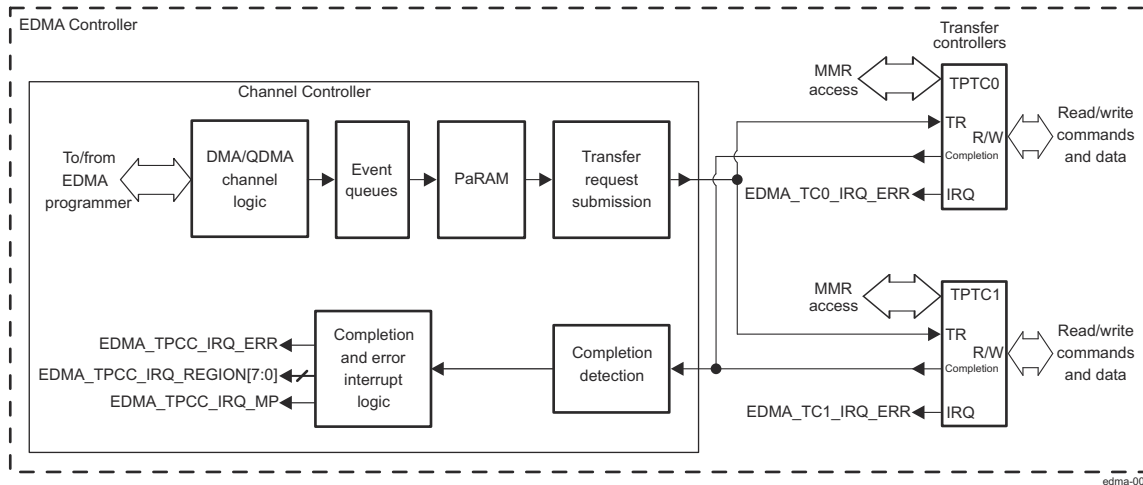

Figure 11-2. EDMA Controller Block Diagram

11.2.3.1.1 Third-Party Channel Controller

The TPCC is the EDMA transfer scheduler responsible for scheduling, arbitrating, and issuing user programmed transfers to the two TPTCs.

Figure 11-3 shows a functional block diagram of the EDMA channel controller (EDMA_TPCC).

The main blocks of the EDMA_TPCC are as follows:

- Parameter RAM (PaRAM): The PaRAM maintains parameter sets for channel and reload parameter sets. The PaRAM must be written with the transfer context for the desired channels and link parameter sets. EDMA_TPCC processes and sets based on a trigger event and submits a transfer request (TR) to the transfer controllers.
- EDMA event and interrupt processing registers: Allows mapping of events to parameter sets, enable/disable events, enable/disable interrupt conditions, and clearing interrupts.
- Completion detection: The completion detect block detects completion of transfers by the EDMA_TPTCs or slave peripherals. The completion of transfers can be used optionally to chain trigger new transfers or to assert interrupts.
- Event queues: Event queues form the interface between the event detection logic and the transfer request submission logic.
- Memory protection registers: Memory protection registers define the accesses (privilege level and requestor(s)) that are allowed to access the DMA channel shadow region view(s) and regions of PaRAM.

Other functions include the following:

- Region registers: Region registers allow DMA resources (DMA channels and interrupts) to be assigned to unique regions that different EDMA programmers own (for example, DSPs).
- Debug registers: Debug registers allow debug visibility by providing registers to read the queue status, controller status, and missed event status.

The EDMA_TPCC includes two channel types: DMA channels (64 channels) and QDMA channels (8 channels).

Each channel is associated with a given event queue/transfer controller and with a given PaRAM set. The main difference between a DMA channel and a QDMA channel is the method that the system uses to trigger transfers.

Figure 11-3 is a block diagram of the EDMA_TPCC.

ADVANCE INFORMATION

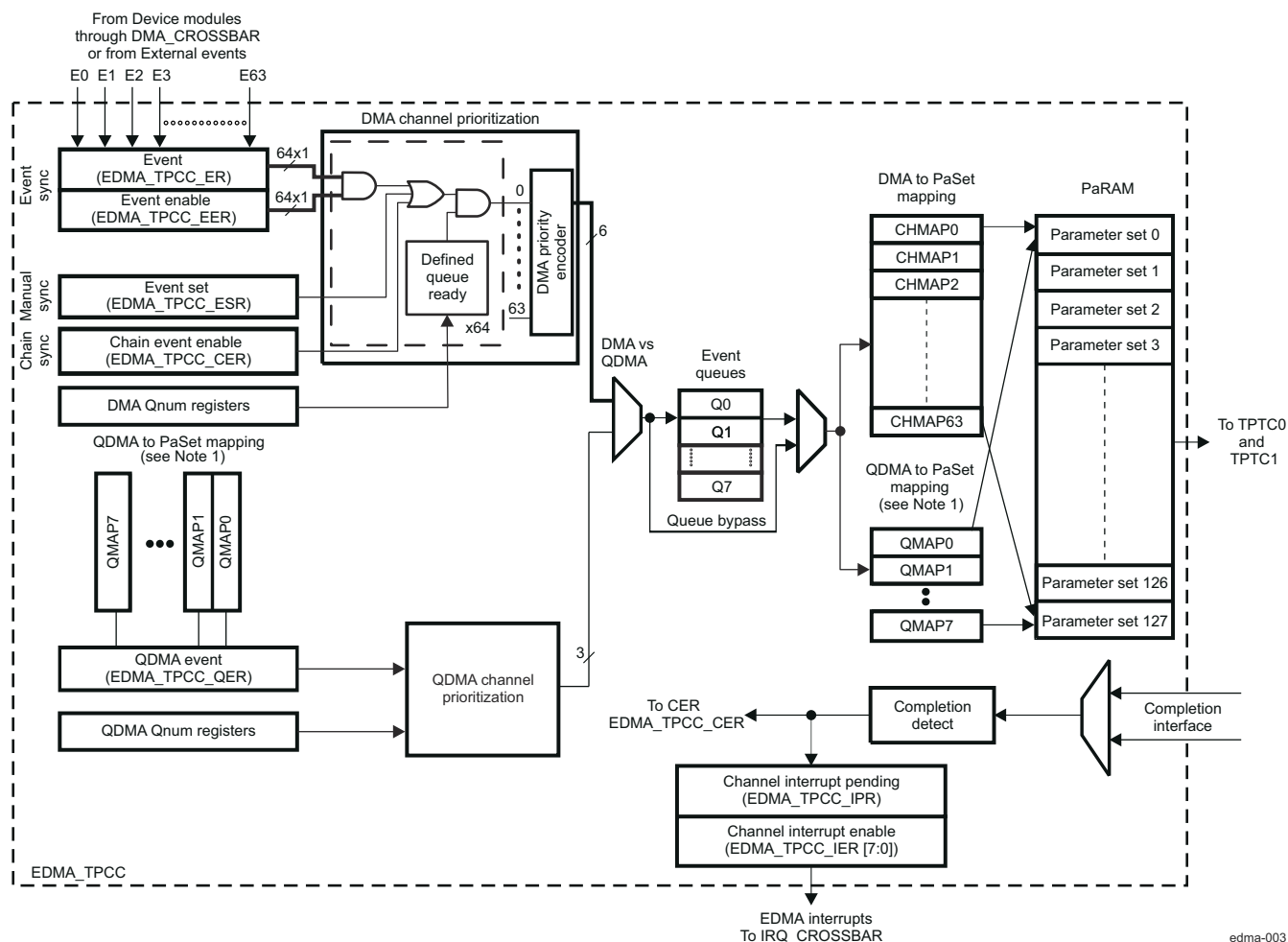

Figure 11-3. EDMA Channel Controller Block Diagram

A. Although it is depicted twice in Figure 11-3, there is only one physical register set for the QDMA to PaRAM set mapping block.

The EDMA_TPCC supports up to 64 DMA channels and up to 8 QDMA channels. These channels are identical, except for how they are triggered:

- DMA channels are triggered by external events by the event set registers EDMA_TPCC_ESR and EDMA_TPCC_ESRH, or through chaining register EDMA_TPCC_CER.
- QDMA channels are triggered automatically (auto-triggered) by the CPU. QDMAs allow a minimum number of linear writes to be issued to the TPCC to force a series of transfers to occur.

The TPCC arbitrates among pending DMA and QDMA events with a fixed [64:1] and [8:1] priority encoder for these events, respectively (a low channel number corresponds to a high priority).

DMA events are always higher priority than QDMA events. The higher-priority event is placed in the event queue to await submission to the transfer controllers, which occurs at the earliest opportunity. Each event queue is serviced in FIFO order, with a maximum of 16 queued events per event queue. If more than one TPTC is ready to be programmed with a transmission request (TR), the event queues are serviced with fixed priority: Q0 is higher than Q1. When an event is ready to be queued and the event queue and the TC channel are empty, the event bypasses the event queue and goes directly to the PaRAM processing logic for submission to the appropriate TC. If the transfer request TR bus or PaRAM processing are busy, the bypass path is not used. The bypass is not used to dequeue for a higher-priority event.

Events are extracted from the event queue when the EDMA_TPTC is available for a new TR to be programmed into the EDMA_TPTC (signaled with the empty signal, indicating an empty program register set). As an event is extracted from the event queue, the associated PaRAM entry is processed and submitted to the TPTC as a TR. The TPCC updates the appropriate counts and addresses in the PaRAM entry in anticipation of the next trigger event for that PaPARAM entry.

The EDMA_TPCC also has an error detection logic that causes an error interrupt generation on various error conditions (for example: missed events EDMA_TPCC_EMR and EDMA_TPCC_EMRH registers, exceeding event queue thresholds in EDMA_TPCC_CCERR register, etc.).

11.2.3.1.2 Third-Party Transfer Controller

The TPTC module is the EDMA transfer engine that generates transfers as programmed in dedicated working registers, using two dedicated controller ports: a read-only port and a write-only port.

Figure 11-4 shows a functional block diagram and of the EDMA transfer controller (EDMA_TPTC) and its connection to the EDMA_TPCC.

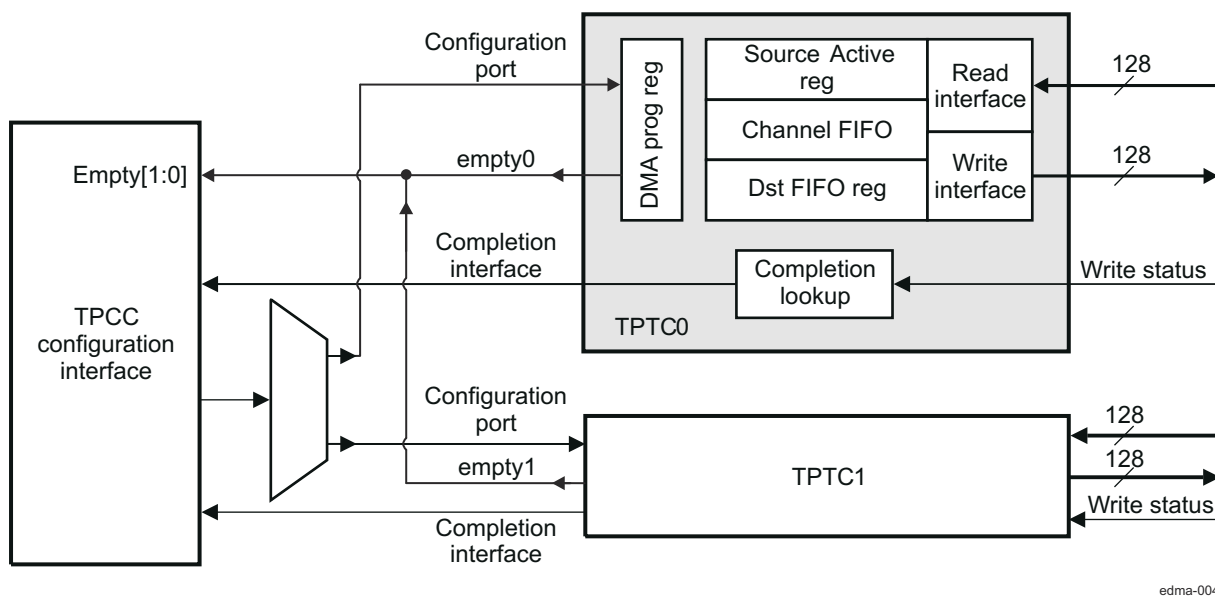

Figure 11-4. TPTC Block Diagram

Note

The port data bus width of the instances of the TPTC is fixed at 128 bits.

Two instances of the EDMA_TPTC generate concurrent traffic on the L3_MAIN interconnect. Each TC controller consists of the following components:

- **DMA Program Register Set:** Stores the context for the DMA transfer that is loaded into the active register set when the current active register set completes. The CPU or TPCC programs the Program Register Set, not the active register set. For typical standalone operation, the CPU programs the Program Register while the TC services the Active register set. The Program Register set includes ownership control such that CPU software and the EDMA stay synchronized relative to one another.
- **Source Active Register Set :** Stores the context (src/dst/cnt/etc) for the DMA Transfer Request (TR) in progress in the Read Controller. The Active register set is split into independent Source and Destination, because the source interconnect controller and the distant interconnect controller operate independently of one another.
- **Destination FIFO Register Set:** Stores the context (src/dst/cnt/etc) for the DMA Transfer Request (TR) in progress, or pending, in the Write Controller. The pending register must allow the source controller to begin processing a new TR while the distant register set processes the previous TR.

- Channel FIFO: Temporary holding buffer for in-flight data. The read return data of the source peripheral is stored in the Data FIFO, and then is written to the destination peripheral by the write command/data bus.
- Read Controller/Interconnect Read Interface: The Interconnect read interface issues optimally sized read commands to the source peripheral, based on a burst size of 128 bytes and available landing space in the channel FIFO.
- Write controller/Interconnect Write interface: The local interconnect write interface issues optimally sized write commands to the destination peripheral, based on a burst size of 128 bytes and available data in the channel FIFO.
- Completion interface: sends completion codes to the EDMA_TPCC when a transfer completes and generates interrupts and chained events in the TPCC module.
- Configuration port: Target interface that provides read/write access to program registers and read access to all memory-mapped TPTC registers.

When one EDMA_TPTC module is idle and receive its first TR, DMA program register set receives the TR, where it transitions to the DMA source active set and the destination FIFO register set immediately. The second TR (if pending from EDMA_TPCC) is loaded into the DMA program set, ensuring it can start as soon as possible when the active transfer completes. As soon as the current active set is exhausted, the TR is loaded from the DMA program register set into the DMA source active register set as well as to the appropriate entry in the destination FIFO register set.

The read controller issues read commands controlled by the rules of command fragmentation and optimization. These are issued only when the data FIFO has space available for the data read. When sufficient data is in the data FIFO, the write controller starts issuing a write command again following the rules for command fragmentation and optimization.

Depending on the number of entries, the read controller can process up to two or four transfer requests ahead of the destination subject to the amount of free data FIFO.

11.2.3.2 Types of EDMA controller Transfers

An EDMA transfer is always defined in terms of three dimensions. [Figure 11-5](#) shows the three dimensions used by EDMA controller transfers. These three dimensions are defined as:

- 1st Dimension or Array (A): The 1st dimension in a transfer consists of EDMA_TPCC_ABCNT_n[15:0] ACNT contiguous bytes.
- 2nd Dimension or Frame (B): The 2nd dimension in a transfer consists of EDMA_TPCC_ABCNT_n[31:16] BCNT arrays of ACNT bytes. Each array transfer in the 2nd dimension is separated from each other by an index programmed using bit-fields EDMA_TPCC_BIDX_n[15:0] SBIDX or EDMA_TPCC_BIDX_n[31:16] DBIDX.
- 3rd Dimension or Block (C): The 3rd dimension in a transfer consists of CCNT frames of BCNT arrays of ACNT bytes. The Count for 3rd Dimension is defined in register EDMA_TPCC_CCNT_n[15:0] CCNT. Each transfer in the 3rd dimension is separated from the previous by an index programmed using EDMA_TPCC_CIDX_n[15:0] SCIDX or EDMA_TPCC_CIDX_n[31:16] DCIDX.

Note

The reference point for the index depends on the synchronization type. The amount of data transferred upon receipt of a trigger/synchronization event is controlled by the synchronization types (EDMA_TPCC_OPT_n[2] SYNCDIM bit). For these three dimensions, only two synchronization types are supported: A-synchronized transfers and AB-synchronized transfers.

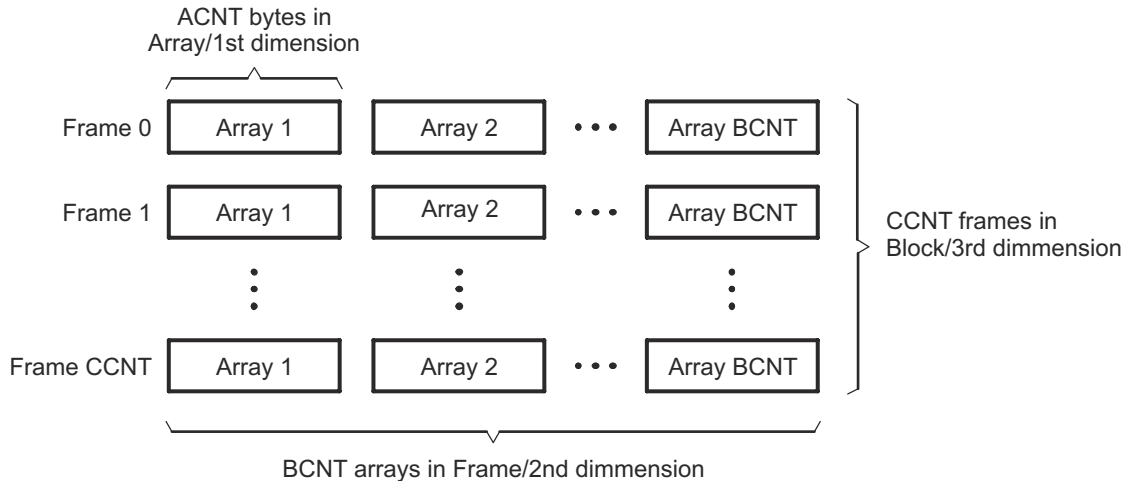

Figure 11-5. Definition of ACNT, BCNT, and CCNT

edma-007

11.2.3.2.1 A-Synchronized Transfers

In an A-synchronized transfer, each EDMA sync event initiates the transfer of the 1st dimension of EDMA_TPCC_ABCNT_n[15:0] ACNT bytes, or one array of ACNT bytes. Each event/TR packet conveys the transfer information for one array only. Thus, BCNT × CCNT events are needed to completely service a PaRAM set.

Arrays are always separated by EDMA_TPCC_BIDX_n[15:0] SBIDX and EDMA_TPCC_BIDX_n[31:16] DBIDX, as shown in Figure 11-6, where the start address of Array N is equal to the start address of Array N – 1 plus source (SRC) or destination (DST) in EDMA_TPCC_BIDX_n register.

Frames are always separated by EDMA_TPCC_CIDX_n[15:0] SCIDX and EDMA_TPCC_CIDX_n[31:16] DCIDX. For A-synchronized transfers, after the frame is exhausted, the address is updated by adding SRCCIDX / DSTCIDX to the beginning address of the last array in the frame. As in Figure 11-6, SRCCIDX / DSTCIDX is the difference between the start of Frame 0 Array 3 to the start of Frame 1 Array 0.

Figure 11-6 shows an A-synchronized transfer of 3 (CCNT) frames of 4 (BCNT) arrays of n (ACNT) bytes. In this example, a total of 12 sync events (BCNT × CCNT) exhaust a PaPARAM set. See Figure 11-6 for details on parameter set updates.

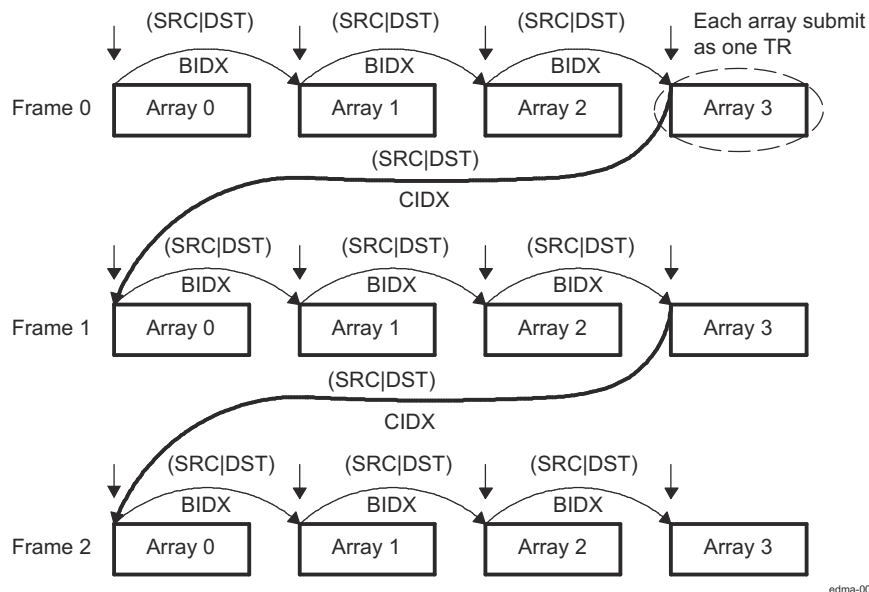

edma-008

Figure 11-6. A-Synchronized Transfers (ACNT = n, BCNT = 4, CCNT = 3)

11.2.3.2.2 AB-Synchronized Transfers

In an AB-synchronized transfer, each EDMA sync event initiates the transfer of 2 dimensions or one frame. Each event/TR packet conveys information for one entire frame of BCNT_n arrays of ACNT_n bytes. Thus, EDMA_TPCC_CCNT_n events are needed to completely service a PaRAM set.

Arrays are always separated by EDMA_TPCC_BIDX_n[15:0] SBIDX and EDMA_TPCC_BIDX_n[31:16] DBIDX as shown in Figure 11-7. Frames are always separated by SRCCIDX and DSTCIDX.

Note that for AB-synchronized transfers, after a TR for the frame is submitted, the address update is to add EDMA_TPCC_CIDX_n[15:0] SCIDX / EDMA_TPCC_CIDX_n[31:16] DCIDX to the beginning address of the beginning array in the frame. This is different from A-synchronized transfers where the address is updated by adding SRCCIDX/DSTCIDX to the start address of the last array in the frame. See Section 11.2.3.3.6 *Parameter Set Updates* for details on parameter set updates.

Figure 11-7 shows an AB-synchronized transfer of 3 (CCNT) frames of 4 (BCNT) arrays of *n* (ACNT) bytes. In this example, a total of 3 sync events (CCNT) exhaust a PaRAM set; that is, a total of 3 transfers of 4 arrays each completes the transfer.

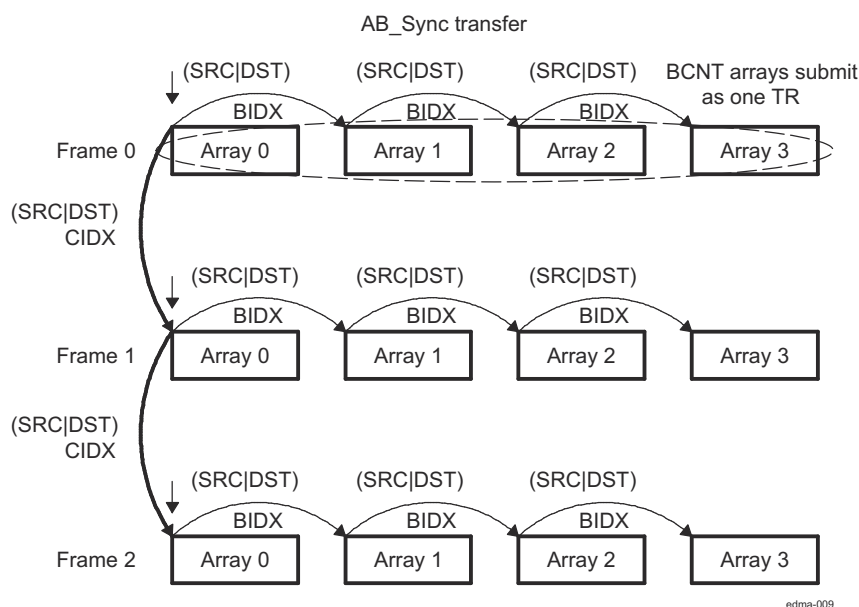

Figure 11-7. AB-Synchronized Transfers (ACNT = *n*, BCNT = 4, CCNT = 3)

Note

ABC-synchronized transfers are not directly supported. It can be logically achieved by chaining between multiple AB-synchronized transfers.

11.2.3.3 Parameter RAM (PaRAM)

The EDMA controller is a RAM-based architecture. The transfer context (source/destination addresses, count, indexes, etc.) for DMA or QDMA channels is programmed in a parameter RAM table in EDMA_TPCC. The PaRAM table is segmented into multiple PaRAM sets. Each PaRAM set includes eight four-byte PaRAM set entries (32-bytes total per PaRAM set), which includes typical DMA transfer parameters such as source address, destination address, transfer counts, indexes, options, etc.

The PaRAM structure supports flexible ping-pong, circular buffering, channel chaining, and auto-reloading (linking).

The contents of the PaRAM include the following:

- 256 PaRAM sets

- 64 channels that are direct mapped and can be used as link or QDMA sets if not used for DMA channels
- 8 channels remain for link or QDMA sets

By default, all channels map to PaRAM set to 0, they should be remapped before use by EDMA_TPCC_DCHMAPN_m and EDMA_TPCC_QCHMAPN_j registers.

Table 11-7. EDMA Parameter RAM Contents

PaRAM Set Number	Base Address	Parameters
0	EDMA Base Address + 4000h to EDMA Base Address + 401Fh	PaRAM set 0
1	EDMA Base Address + 4020h to EDMA Base Address + 403Fh	PaRAM set 1
2	EDMA Base Address + 4040h to EDMA Base Address + 405Fh	PaRAM set 2
3	EDMA Base Address + 4060h to EDMA Base Address + 407Fh	PaRAM set 3
4	EDMA Base Address + 4080h to EDMA Base Address + 409Fh	PaRAM set 4
5	EDMA Base Address + 40A0h to EDMA Base Address + 40BFh	PaRAM set 5
6	EDMA Base Address + 40C0h to EDMA Base Address + 40DFh	PaRAM set 6
7	EDMA Base Address + 40E0h to EDMA Base Address + 40FFh	PaRAM set 7
8	EDMA Base Address + 4100h to EDMA Base Address + 411Fh	PaRAM set 8
9	EDMA Base Address + 4120h to EDMA Base Address + 413Fh	PaRAM set 9
...
63	EDMA Base Address + 47E0h to EDMA Base Address + 47FFh	PaRAM set 63
64	EDMA Base Address + 4800h to EDMA Base Address + 481Fh	PaRAM set 64
65	EDMA Base Address + 4820h to EDMA Base Address + 483Fh	PaRAM set 65
...
127	EDMA Base Address + 5000h to EDMA Base Address + 4FE0h	PaRAM set 127
128	EDMA Base Address + 5020h to EDMA Base Address + 503Fh	PaRAM set 128
129	EDMA Base Address + 5040h to EDMA Base Address + 505Fh	PaRAM set 129
130	EDMA Base Address + 5060h to EDMA Base Address + 507Fh	PaRAM set 130
...
256	EDMA Base Address + 6000h to EDMA Base Address + 601Fh	PaRAM set 256

Note

AM273x has a maximum of 128 PaRAM sets. Additional tables and diagrams in this chapter may show a larger number (up to 511), however 128 is the maximum allowed number of entries.

11.2.3.3.1 PaRAM

Each parameter set of PaRAM is organized into eight 32-bit words or 32 bytes, as shown in [PaRAM Set](#) and described in [EDMA Channel Parameter Description](#). Each PaRAM set consists of 16-bit and 32-bit parameters.

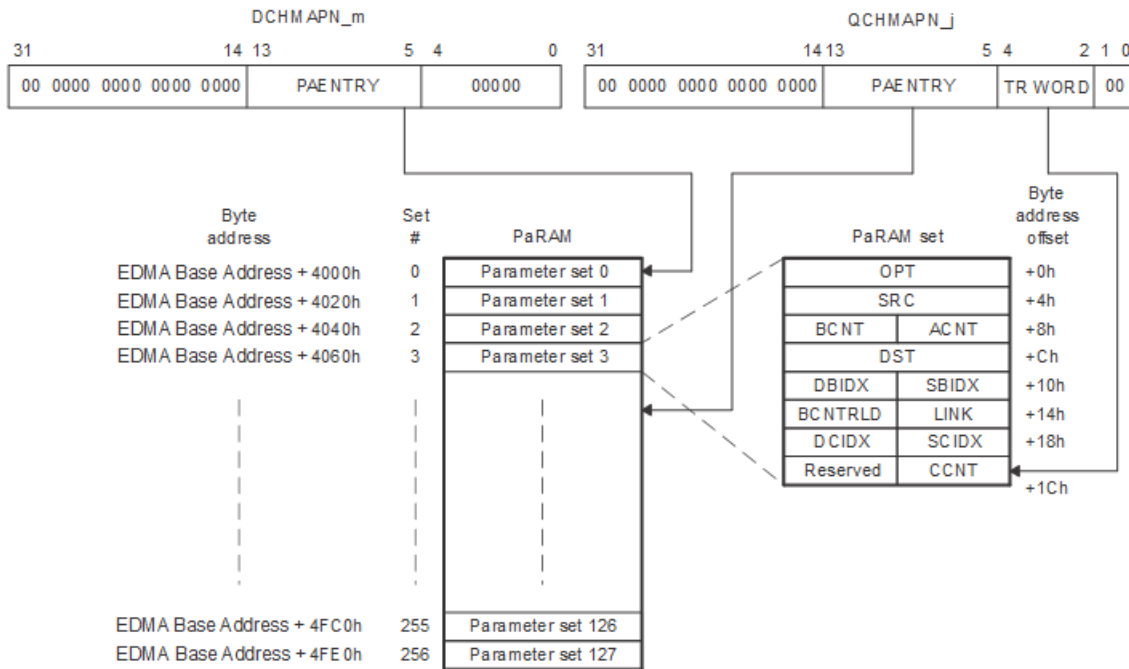

Figure 11-8. PaRAM Set

Note

Figure above is a representation of 128 bit entries. For device specific details please refer to [EDMA configuration](#) chapter.

ADVANCE INFORMATION

Table 11-8. EDMA Channel Parameter Description

Offset Address (bytes)	Acronym	Parameter	Description
0h	OPT	Channel Options EDMA_TPCC_OPT_n register	Transfer configuration options
4h	SRC	Channel Source Address EDMA_TPCC_SRC_n register	The byte address from which data is transferred
8h	ACNT	Count for 1st Dimension EDMA_TPCC_ABCNT_n[15:0] ACNT bit-field.	Unsigned value specifying the number of contiguous bytes within an array (first dimension of the transfer). Valid values range from 1 to 65 535.
	BCNT	Count for 2nd Dimension EDMA_TPCC_ABCNT_n[31:16] BCNT bit-field.	Unsigned value specifying the number of arrays in a frame, where an array is ACNT bytes. Valid values range from 1 to 65 535.
Ch	DST	Channel Destination Address EDMA_TPCC_DST_n register	The byte address to which data is transferred
10h	SBIDX	Source BCNT Index EDMA_TPCC_BIDX_n[15:0] SBIDX bit-field.	Signed value specifying the byte address offset between source arrays within a frame (2nd dimension). Valid values range from -32 768 and 32 767.
	DBIDX	Destination BCNT Index EDMA_TPCC_BIDX_n[31:16] DBIDX bit-field.	Signed value specifying the byte address offset between destination arrays within a frame (2nd dimension). Valid values range from -32 768 and 32 767.
14h	LINK	Link Address EDMA_TPCC_LNK_n[15:0] LINK bit-field	The PaRAM address containing the PaRAM set to be linked (copied from) when the current PaRAM set is exhausted. A value of FFFFh specifies a null link.
	BCNTRLD	BCNT Reload EDMA_TPCC_LNK_n[31:16] BCNTRLD bit-field	The count value used to reload BCNT when BCNT decrements to 0 (TR is submitted for the last array in 2nd dimension). Only relevant in A-synchronized transfers.
18h	SCIDX	Source CCNT index. EDMA_TPCC_CIDX_n[15:0] SCIDX bit-field.	Signed value specifying the byte address offset between frames within a block (3rd dimension). Valid values range from -32 768 and 32 767. A-synchronized transfers: The byte address offset from the beginning of the last source array in a frame to the beginning of the first source array in the next frame. AB-synchronized transfers: The byte address offset from the beginning of the first source array in a frame to the beginning of the first source array in the next frame.
	DCIDX	Destination CCNT index. EDMA_TPCC_CIDX_n[31:16] DCIDX bit-field.	Signed value specifying the byte address offset between frames within a block (3rd dimension). Valid values range from -32 768 and 32 767. A-synchronized transfers: The byte address offset from the beginning of the last destination array in a frame to the beginning of the first destination array in the next frame. AB-synchronized transfers: The byte address offset from the beginning of the first destination array in a frame to the beginning of the first destination array in the next frame.
1Ch	CCNT	Count for 3rd Dimension. EDMA_TPCC_CCNT_n[15:0] CCNT bit-field.	Unsigned value specifying the number of frames in a block, where a frame is BCNT arrays of ACNT bytes. Valid values range from 1 to 65 535.
	Reserved	Reserved	Reserved. Always write 0 to this bit; writes of 1 to this bit are not supported and attempts can result in undefined behavior.

11.2.3.3.2 EDMA Channel PaRAM Set Entry Fields

11.2.3.3.2.1 Channel Options Parameter (OPT)

For detailed information about the channel options parameter, see the EDMA_TPCC_OPT_n register description in [Section 11.2.6](#).

11.2.3.3.2.2 Channel Source Address (SRC)

The 32-bit source address parameter specifies the starting byte address of the source. For SAM in increment mode, there are no alignment restrictions imposed by EDMA. For SAM in constant addressing mode, it must program the source address to be aligned to a 256-bit aligned address (5 LSBs of address must be 0). If this rule is not observed, the EDMA_TPTC returns an error. Refer to [Section 11.2.3.12.3 Error Generation](#) for additional details.

11.2.3.3.2.3 Channel Destination Address (DST)

The 32-bit destination address parameter specifies the starting byte address of the destination. For DAM in increment mode, there are no alignment restrictions imposed by EDMA. For DAM in constant addressing mode, it must program the destination address to be aligned to a 256-bit aligned address (5 LSBs of address must be 0). If this rule is not observed, the EDMA_TPTC returns an error. Refer to [Section 11.2.3.12.3 Error Generation](#) for additional details.

11.2.3.3.2.4 Count for 1st Dimension (ACNT)

EDMA_TPCC_ABCNT_n[15:0] ACNT represents the number of bytes within the 1st dimension of a transfer. ACNT is a 16-bit unsigned value with valid values between 0 and 65 535. Therefore, the maximum number of bytes in an array is 65 535 bytes (64K – 1 bytes). ACNT must be greater than or equal to 1 for a TR to be submitted to EDMA_TPTC. A transfer with ACNT equal to 0 is considered either a null or dummy transfer. A dummy or null transfer generates a completion code depending on the settings of the completion bit fields in EDMA_TPCC_OPT_n.

Refer to [Section 11.2.3.3.5 Dummy Versus Null Transfer Comparison](#) and [Section 11.2.3.5.3 Dummy or Null Completion](#) for details on dummy/null completion conditions.

11.2.3.3.2.5 Count for 2nd Dimension (BCNT)

EDMA_TPCC_ABCNT_n[15:0] BCNT is a 16-bit unsigned value that specifies the number of arrays of length ACNT. For normal operation, valid values for BCNT are between 1 and 65 535. Therefore, the maximum number of arrays in a frame is 65 535 (64K – 1 arrays). A transfer with BCNT equal to 0 is considered either a null or dummy transfer. A dummy or null transfer generates a completion code depending on the settings of the completion bit fields in EDMA_TPCC_OPT_n.

Refer to [Section 11.2.3.3.5 Dummy Versus Null Transfer Comparison](#) and [Section 11.2.3.5.3 Dummy or Null Completion](#) for details on dummy/null completion conditions.

11.2.3.3.2.6 Count for 3rd Dimension (CCNT)

EDMA_TPCC_CCNT_n[15:0] CCNT is a 16-bit unsigned value that specifies the number of frames in a block. Valid values for CCNT are between 1 and 65 535. Therefore, the maximum number of frames in a block is 65 535 (64K – 1 frames). A transfer with CCNT equal to 0 is considered either a null or dummy transfer. A dummy or null transfer generates a completion code depending on the settings of the completion bit fields in EDMA_TPCC_OPT_n.

A CCNT value of 0 is considered either a null or dummy transfer.

Refer to [Section 11.2.3.3.5 Dummy Versus Null Transfer Comparison](#) and [Section 11.2.3.5.3 Dummy or Null Completion](#) for details on dummy/null completion conditions.

11.2.3.3.2.7 BCNT Reload (BCNTRLD)

EDMA_TPCC_LNK_n[31:16] BCNTRLD is a 16-bit unsigned value used to reload the EDMA_TPCC_ABCNT_n[15:0] BCNT field once the last array in the 2nd dimension is transferred. This field is only used for A-synchronized transfers. In this case, the EDMA_TPCC decrements the BCNT value by 1 on

each TR submission. When BCNT reaches 0, the EDMA_TPCC decrements CCNT and uses the BCNTRLD value to reinitialize the BCNT value.

For AB-synchronized transfers, the EDMA_TPCC submits the BCNT in the TR and the EDMA_TPTC decrements BCNT appropriately. For AB-synchronized transfers, BCNTRLD is not used.

11.2.3.3.2.8 Source B Index (SBIDX)

EDMA_TPCC_BIDX_n[15:0] SBIDX is a 16-bit signed value (2s complement) used for source address modification between each array in the 2nd dimension. Valid values for EDMA_TPCC_BIDX_n[15:0] SBIDX are between -32 768 and 32 767. It provides a byte address offset from the beginning of the source array to the beginning of the next source array. It applies to both A-synchronized and AB-synchronized transfers. Some examples:

- EDMA_TPCC_BIDX_n[15:0] SBIDX = 0000h (0): no address offset from the beginning of an array to the beginning of the next array. All arrays are fixed to the same beginning address.
- EDMA_TPCC_BIDX_n[15:0] SBIDX = 0003h (+3): the address offset from the beginning of an array to the beginning of the next array in a frame is 3 bytes. For example, if the current array begins at address 1000h, the next array begins at 1003h.
- EDMA_TPCC_BIDX_n[15:0] SBIDX = FFFFh (-1): the address offset from the beginning of an array to the beginning of the next array in a frame is -1 byte. For example, if the current array begins at address 5054h, the next array begins at 5053h.

11.2.3.3.2.9 Destination B Index (DBIDX)

EDMA_TPCC_BIDX_n[31:16] DBIDX is a 16-bit signed value (2s complement) used for destination address modification between each array in the 2nd dimension. Valid values for EDMA_TPCC_BIDX_n[31:16] DBIDX are between -32 768 and 32 767. It provides a byte address offset from the beginning of the destination array to the beginning of the next destination array within the current frame. It applies to both A-synchronized and AB-synchronized transfers. Refer to [Section 11.2.3.3.2.8 Source B Index \(SBIDX\)](#) for examples.

11.2.3.3.2.10 Source C Index (SCIDX)

EDMA_TPCC_CIDX_n[15:0] SCIDX is a 16-bit signed value (2s complement) used for source address modification in the 3rd dimension. Valid values for EDMA_TPCC_CIDX_n[15:0] SCIDX are between -32 768 and 32 767. It provides a byte address offset from the beginning of the current array (pointed to by SRC address) to the beginning of the first source array in the next frame. It applies to both A-synchronized and AB-synchronized transfers.

Note

When SCIDX is applied, the current array in an A-synchronized transfer is the last array in the frame ([Figure 11-6](#)), while the current array in an AB-synchronized transfer is the first array in the frame ([Figure 11-7](#)).

11.2.3.3.2.11 Destination C Index (DCIDX)

EDMA_TPCC_CIDX_n[31:16] DCIDX is a 16-bit signed value (2s complement) used for destination address modification in the 3rd dimension. Valid values are between -32 768 and 32 767. It provides a byte address offset from the beginning of the current array (pointed to by DST address) to the beginning of the first destination array TR in the next frame. It applies to both A-synchronized and AB-synchronized transfers.

Note

When DCIDX is applied, the current array in an A-synchronized transfer is the last array in the frame ([Figure 11-6](#)), while the current array in a AB-synchronized transfer is the first array in the frame ([Figure 11-7](#)).

11.2.3.3.2.12 Link Address (LINK)

The EDMA_TPCC provides a mechanism, called linking, to reload the current PaRAM set upon its natural termination (that is, after the count fields are decremented to 0) with a new PaRAM set. The 16-bit parameter EDMA_TPCC_LNK_n[15:0] LINK specifies the byte address offset in the PaRAM from which the EDMA_TPCC loads/reloads the next PaRAM set during linking.

It must program the link address to point to a valid aligned 32-byte PaRAM set. The 5 LSBs of the LINK field should be cleared to 0.

The EDMA_TPCC ignores the upper 2 bits of the LINK entry, allowing the flexibility of programming the link address as either an absolute/literal byte address or use the PaRAM-base-relative offset address. Therefore, if it use the literal address with a range from 4000h to 7FFFh, it will be treated as a PaRAM-base-relative value of 0000h to 3FFFh.

It should check that the programmed value in the EDMA_TPCC_LNK_n[15:0] LINK field is correctly, so that link update is requested from a PaRAM address that falls in the range of the available PaRAM addresses on the device.

Value of FFFFh in EDMA_TPCC_LNK_n[15:0] LINK bit-field is referred to as a NULL link that should cause the EDMA_TPCC to perform an internal write of 0 to all entries of the current PaRAM set, except for the EDMA_TPCC_LNK_n[15:0] LINK field is set to FFFFh. Also, see [Section 11.2.3.5 Completion of a DMA Transfer](#) for details on terminating a transfer.

11.2.3.3.3 Null PaRAM Set

A null PaRAM set is defined as a PaRAM set where all count fields (EDMA_TPCC_ABCNT_n[15:0] ACNT, EDMA_TPCC_ABCNT_n[31:16] BCNT, and EDMA_TPCC_CCNT_n[15:0] CCNT) are cleared to 0. If a PaRAM set associated with a channel is a NULL set, then when serviced by the EDMA_TPCC, the bit corresponding to the channel is set in the associated event missed register (EDMA_TPCC_EMR, EDMA_TPCC_EMRH, or EDMA_TPCC_QEMR). This bit remains set in the associated secondary event register (EDMA_TPCC_SER, EDMA_TPCC_SERH, or EDMA_TPCC_QSER).

This implies that any future events on the same channel are ignored by the EDMA_TPCC and it is required to clear the bit in EDMA_TPCC_SER, EDMA_TPCC_SERH, or EDMA_TPCC_QSER for the channel. This is considered an error condition, since events are not expected on a channel that is configured as a null transfer.

11.2.3.3.4 Dummy PaRAM Set

A dummy PaRAM set is defined as a PaRAM set where at least one of the count fields (EDMA_TPCC_ABCNT_n[15:0] ACNT, EDMA_TPCC_ABCNT_n[31:16] BCNT, or EDMA_TPCC_CCNT_n[15:0] CCNT) is cleared to 0 and at least one of the count fields is nonzero.

If a PaRAM set associated with a channel is a dummy set, then when serviced by the EDMA_TPCC, it will not set the bit corresponding to the channel (DMA/QDMA) in the event missed register (EDMA_TPCC_EMR, EDMA_TPCC_EMRH, or EDMA_TPCC_QEMR) and the secondary event register (EDMA_TPCC_SER, EDMA_TPCC_SERH, or EDMA_TPCC_QSER) bit gets cleared similar to a normal transfer. Future events on that channel are serviced. A dummy transfer is a legal transfer of 0 bytes.

11.2.3.3.5 Dummy Versus Null Transfer Comparison

There are some differences in the way the EDMA_TPCC logic treats a dummy versus a null transfer request. A null transfer request is an error condition, but a dummy transfer is a legal transfer of 0 bytes. A null transfer causes an error bit (En) in EDMA_TPCC_EMR to get set and the En bit in EDMA_TPCC_SER remains set, essentially preventing any further transfers on that channel without clearing the associated error registers.

[Table 11-9](#) summarizes the conditions and effects of null and dummy transfer requests.

Table 11-9. Dummy and Null Transfer Request

Feature	Null TR	Dummy TR
EDMA_TPCC_EMR / EDMA_TPCC_EMRH / EDMA_TPCC_QEMR is set	Yes	No
EDMA_TPCC_SER / EDMA_TPCC_SERH / EDMA_TPCC_QSER remains set	Yes	No

Table 11-9. Dummy and Null Transfer Request (continued)

Feature	Null TR	Dummy TR
Link update (STATIC = 0 in EDMA_TPCC_OPT_n)	Yes	Yes
EDMA_TPCC_QER is set	Yes	Yes
EDMA_TPCC_IPR / EDMA_TPCC_IPRH, EDMA_TPCC_CER / EDMA_TPCC_CERH is set using early completion	Yes	Yes

11.2.3.3.6 Parameter Set Updates

When a TR is submitted for a given DMA/QDMA channel and its corresponding PaRAM set, the EDMA_TPCC is responsible for updating the PaRAM set in anticipation of the next trigger event. For events that are not final, this includes address and count updates; for final events, this includes the link update.

The specific PaRAM set entries that are updated depend on the channel's synchronization type (A-synchronized or AB-synchronized) and the current state of the PaRAM set. A B-update refers to the decrementing of EDMA_TPCC_ABCNT_n[31:16] BCNT in the case of A-synchronized transfers after the submission of successive TRs. A C-update refers to the decrementing of CCNT in the case of A-synchronized transfers after BCNT TRs for EDMA_TPCC_ABCNT_n[15:0] ACNT byte transfers have submitted. For AB-synchronized transfers, a C-update refers to the decrementing of EDMA_TPCC_CCNT_n[15:0] CCNT after submission of every transfer request.

Refer to [Table 11-10](#) for details and conditions on the parameter updates. A link update occurs when the PaRAM set is exhausted, as described in [Section 11.2.3.3.7 Linking Transfers](#).

After the TR is read from the PaRAM (and is in process of being submitted to EDMA_TPTC), the following fields are updated if needed:

- A-synchronized: BCNT, CCNT, SRC, DST.
- AB-synchronized: CCNT, SRC, DST.

The following fields are not updated (except for during linking, where all fields are overwritten by the link PaRAM set):

- A-synchronized: EDMA_TPCC_ABCNT_n[15:0] ACNT, EDMA_TPCC_LNK_n[31:16] BCNTRLD, EDMA_TPCC_BIDX_n[15:0] SBIDX, EDMA_TPCC_BIDX_n[31:16] DBIDX, EDMA_TPCC_CIDX_n[15:0] SCIDX, EDMA_TPCC_CIDX_n[31:16] DCIDX, EDMA_TPCC_OPT_n, EDMA_TPCC_LNK_n[15:0] LINK.
- AB-synchronized: EDMA_TPCC_ABCNT_n[15:0] ACNT, EDMA_TPCC_ABCNT_n[31:16] BCNT, EDMA_TPCC_LNK_n[31:16] BCNTRLD, EDMA_TPCC_BIDX_n[15:0] SBIDX, EDMA_TPCC_BIDX_n[31:16] DBIDX, EDMA_TPCC_CIDX_n[15:0] SCIDX, EDMA_TPCC_CIDX_n[31:16] DCIDX, EDMA_TPCC_OPT_n, EDMA_TPCC_LNK_n[15:0] LINK.

Note

PaRAM updates only pertain to the information that is needed to properly submit the next transfer request to the EDMA_TPTC. Updates that occur while data is moved within a transfer request are tracked within the transfer controller, and is detailed in [Section 11.2.3.12 EDMA Transfer Controller \(EDMA_TPTC\)](#). For A-synchronized transfers, the EDMA_TPCC always submits a TRP for EDMA_TPCC_ABCNT_n[15:0] ACNT bytes (EDMA_TPCC_ABCNT_n[31:16] BCNT = 1 and EDMA_TPCC_CCNT_n[15:0] CCNT = 1). For AB-synchronized transfers, the EDMA_TPCC always submits a TRP for EDMA_TPCC_ABCNT_n[15:0] ACNT bytes of BCNT arrays (EDMA_TPCC_CCNT_n[15:0] CCNT = 1). The EDMA_TPTC is responsible for updating source and destination addresses within the array based on EDMA_TPCC_ABCNT_n[15:0] ACNT and EDMA_TPCC_OPT_n[10:8] FWID. For AB-synchronized transfers, the EDMA_TPTC is also responsible to update source and destination addresses between arrays based on EDMA_TPCC_BIDX_n[15:0] SBIDX and EDMA_TPCC_BIDX_n[31:16] DBIDX.

[Table 11-10](#) shows the details of parameter updates that occur within EDMA_TPCC for A-synchronized and AB-synchronized transfers.

Table 11-10. Parameter Updates in EDMA_TPCC (for Non-Null, Non-Dummy PaRAM Set)

	A-Synchronized Transfer			AB-Synchronized Transfer		
	B-Update	C-Update	Link Update	B-Update	C-Update	Link Update
Condition:	BCNT > 1	BCNT == 1 && CCNT > 1	BCNT == 1 && CCNT == 1	N/A	EDMA_TPCC_CCNT_n[15:0] CCNT > 1	EDMA_TPCC_CCNT_n[15:0] CCNT == 1
SRC	+= SBIDX	+= SCIDX	= Link.EDMA_TPCC_SRC_n	in EDMA_TPT C	+= SCIDX	= Link.EDMA_TPCC_SRC_n
DST	+= DBIDX	+= DCIDX	= Link.EDMA_TPCC_DST_n	in EDMA_TPT C	+= DCIDX	= Link.EDMA_TPCC_DST_n
ACNT	None	None	= Link.EDMA_TPCC_ABCNT_n[15:0] ACNT	None	None	= Link.EDMA_TPCC_ABCNT_n[15:0] ACNT
BCNT	-- 1	= BCNTRLD	= Link.EDMA_TPCC_ABCNT_n[31:16] BCNT	in EDMA_TPT C	N/A	= Link.EDMA_TPCC_ABCNT_n[31:16] BCNT
CCNT	None	-- 1	= Link.EDMA_TPCC_CCNT_n[15:0] CCNT	in EDMA_TPT C	-- 1	= Link.EDMA_TPCC_CCNT_n[15:0] CCNT
SBIDX	None	None	= Link.EDMA_TPCC_BIDX_n[15:0] SBIDX	in EDMA_TPT C	None	= Link.EDMA_TPCC_BIDX_n[15:0] SBIDX
DBIDX	None	None	= Link.EDMA_TPCC_BIDX_n[31:16] DBIDX	None	None	= Link.EDMA_TPCC_BIDX_n[31:16] DBIDX
SCIDX	None	None	= Link.EDMA_TPCC_BIDX_n[15:0] SBIDX	in EDMA_TPT C	None	= Link.EDMA_TPCC_BIDX_n[15:0] SBIDX
DCIDX	None	None	= Link.EDMA_TPCC_BIDX_n[31:16] DBIDX	None	None	= Link.EDMA_TPCC_BIDX_n[31:16] DBIDX
LINK	None	None	= Link.EDMA_TPCC_LNK_n[15:0] LINK	None	None	= Link.EDMA_TPCC_LNK_n[15:0] LINK
BCNTRLD	None	None	= Link.EDMA_TPCC_LNK_n[31:16] BCNTRLD	None	None	= Link.EDMA_TPCC_LNK_n[31:16] BCNTRLD
OPT ⁽¹⁾	None	None	= LINK.EDMA_TPCC_OPT_n	None	None	= LINK.EDMA_TPCC_OPT_n

(1) In all cases, no updates occur if EDMA_TPCC_OPT_n[3] STATIC == 1 for the current PaRAM set.

Note

The EDMA_TPCC includes no special hardware to detect when an indexed address update calculation overflows/underflows. The address update will wrap across boundaries as programmed by the user. It should ensure that no transfer is allowed to cross internal port boundaries between peripherals. A single TR must target a single source/destination slave endpoint.

11.2.3.3.7 Linking Transfers

The EDMA_TPCC provides a mechanism known as linking, which allows the entire PaRAM set to be reloaded from a location within the PaRAM memory map (for both DMA and QDMA channels). Linking is especially useful for maintaining ping-pong buffers, circular buffering, and repetitive/continuous transfers with no CPU intervention. Upon completion of a transfer, the current transfer parameters are reloaded with the parameter set pointed to by the 16-bit link address field of the current parameter set. Linking only occurs when the EDMA_TPCC_OPT_n[3] STATIC bit is cleared.

Note

It should always link a transfer (EDMA or QDMA) to another useful transfer. If it must terminate a transfer, then link the transfer to a NULL parameter set. Refer to [Section 11.2.3.3.3 Null PaRAM Set](#).

The link update occurs after the current PaRAM set event parameters have been exhausted. An event's parameters are exhausted when the EDMA channel controller has submitted all of the transfers that are associated with the PaRAM set.

A link update occurs for null and dummy transfers depending on the state of the EDMA_TPCC_OPT_n[3] STATIC bit and the EDMA_TPCC_LNK_n[15:0] LINK field. In both cases (null or dummy), if the value of EDMA_TPCC_LNK_n[15:0] LINK is FFFFh, then a null PaRAM set (with all 0s and EDMA_TPCC_LNK_n[15:0] LINK set to FFFFh) is written to the current PaRAM set.

Similarly, if EDMA_TPCC_LNK_n[15:0] LINK is set to a value other than FFFFh, then the appropriate PaRAM location that EDMA_TPCC_LNK_n[15:0] LINK points to is copied to the current PaRAM set.

Once the channel completion conditions are met for an event, the transfer parameters that are located at the link address are loaded into the current DMA or QDMA channel's associated parameter set. This indicates that the EDMA_TPCC reads the entire set (eight words) from the PaRAM set specified by EDMA_TPCC_LNK_n[15:0] LINK and writes all eight words to the PaRAM set that is associated with the current channel. [Figure 11-9](#) shows an example of a linked transfer.

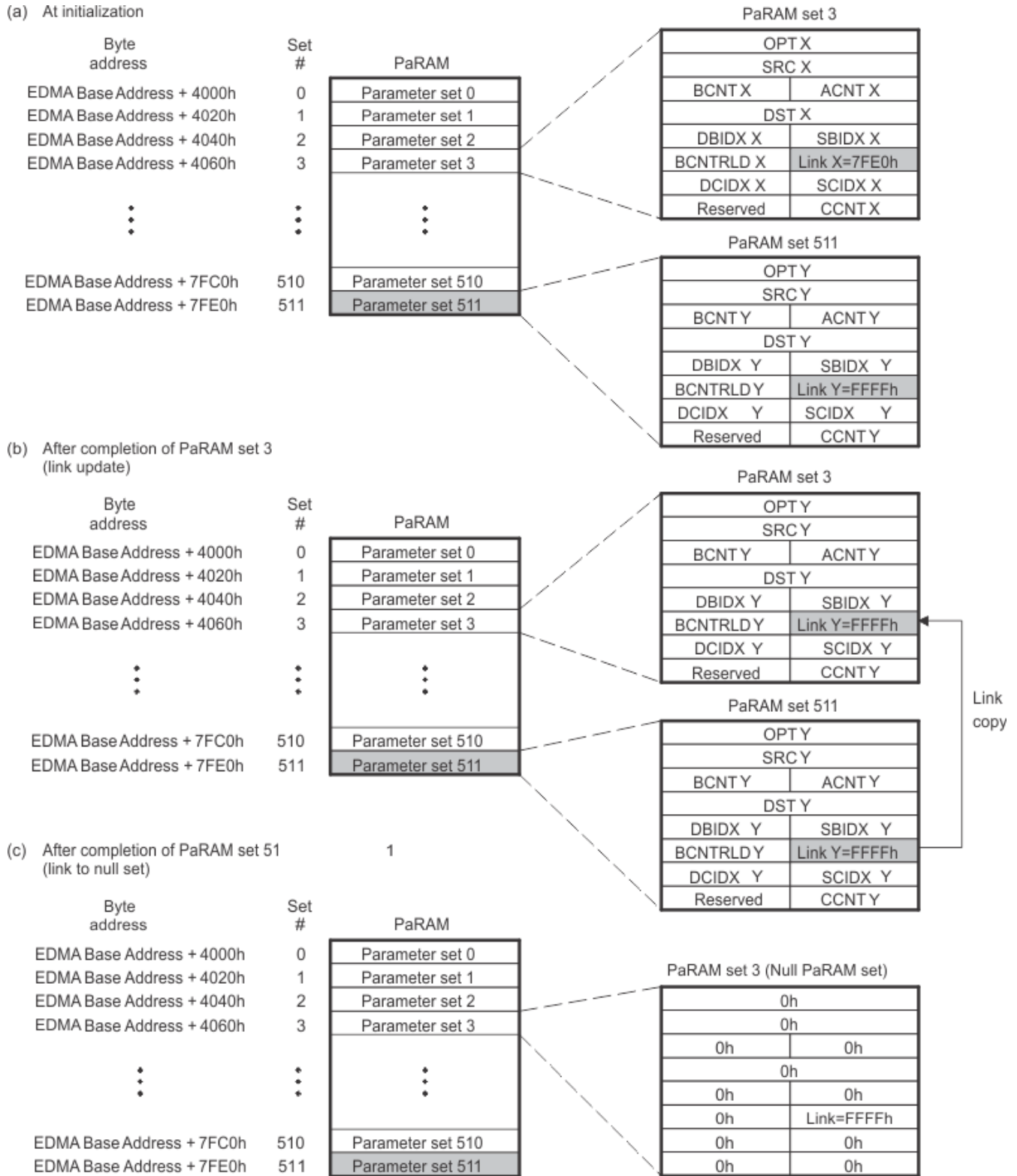

adms-011

Figure 11-9. Linked Transfer

Note

AM273x has a maximum of 128 PaRAM sets. Additional tables and diagrams in this chapter may show a larger number (up to 511), however 128 is the maximum allowed number of entries.

Any PaRAM set in the PaRAM can be used as a link/reload parameter set. The PaRAM sets associated with peripheral synchronization events (refer to [Section 11.2.3.6 Event, Channel, and PaRAM Mapping](#)) only use for linking if the corresponding events are disabled.

If a PaRAM set location is defined as a QDMA channel PaRAM set (by EDMA_TPCC_QCHMAPN_j register), then copying the link PaRAM set into the current QDMA channel PaRAM set is recognized as a trigger event. It is latched in EDMA_TPCC_QER because a write to the trigger word was performed. This feature is used to create a linked list of transfers using a single QDMA channel and multiple PaRAM sets. Refer to [Section 11.2.3.4.2 QDMA Channels](#).

Linking to itself replicates the behavior of auto-initialization, thus facilitating the use of circular buffering and repetitive transfers. After an EDMA channel exhausts its current PaRAM set, it reloads all of the parameter set entries from another PaRAM set, which is initialized with values that are identical to the original PaRAM set. [Figure 11-10](#) shows an example of a linked to self transfer. Here, the PaRAM set 511 has the link field pointing to the address of parameter set 511 (linked to self).

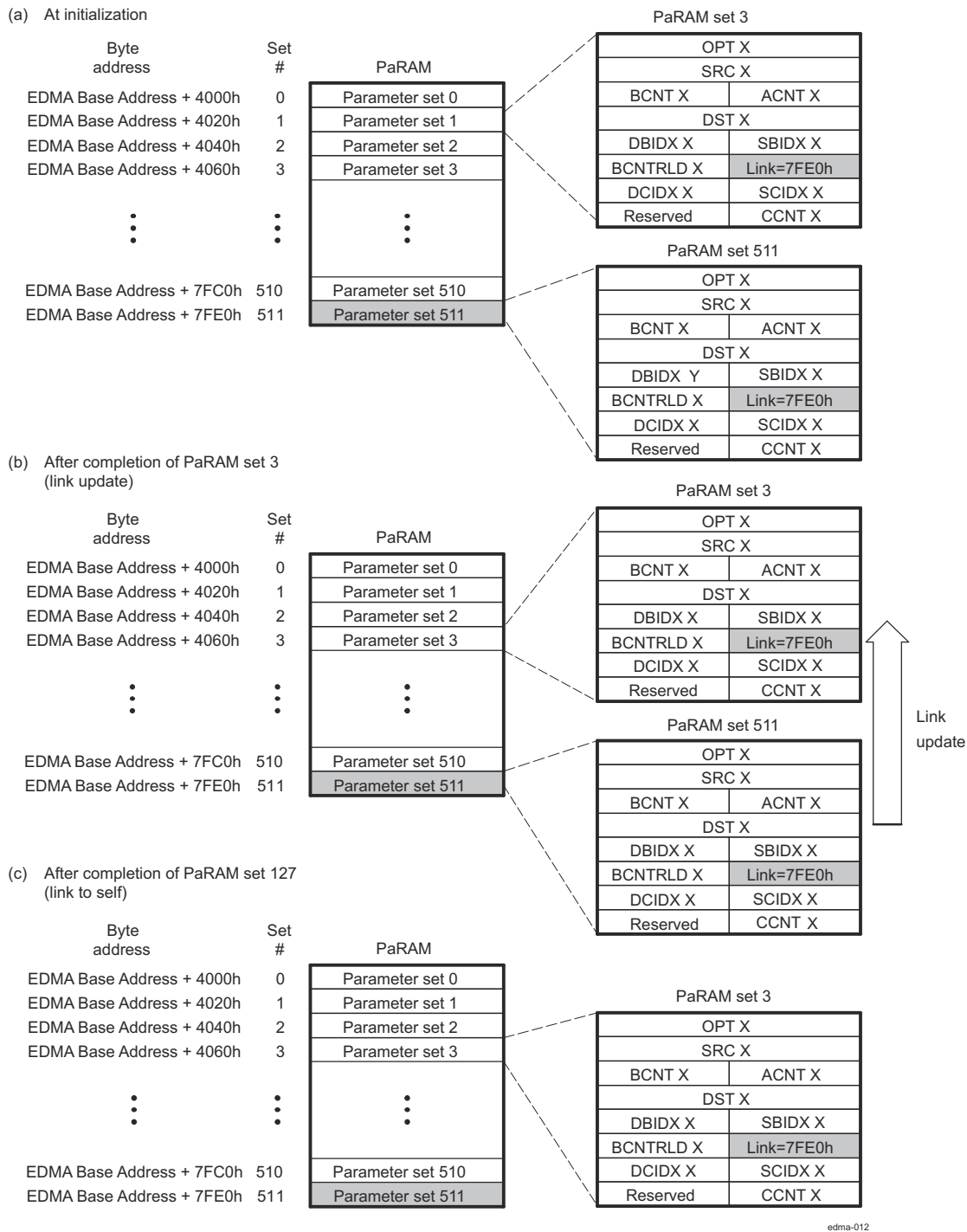

Figure 11-10. Link-to-Self Transfer

Note

If the in EDMA_TPCC_OPT_n[3] STATIC bit is set for a PaRAM set, then link updates are not performed.

11.2.3.3.8 Constant Addressing Mode Transfers/Alignment Issues

If either EDMA_TPCC_OPT_n[0] SAM or EDMA_TPCC_OPT_n[1] DAM is set (constant addressing mode), then the source or destination address must be aligned to a 256-bit aligned address, respectively, and the

corresponding EDMA_TPCC_BIDX_n is an even multiple of 32 bytes (256 bits). The EDMA_TPCC does not recognize errors here, but the EDMA_TPTC asserts an error if this is not true. Refer to [Section 11.2.3.12.3 Error Generation](#).

Note

The constant addressing (CONST) mode has limited applicability. The EDMA is configured for the constant addressing mode (EDMA_TPCC_OPT_n[0] SAM / EDMA_TPCC_OPT_n[1] DAM = 1) only if the transfer source or destination (on-chip memory, off-chip memory controllers, slave peripherals) support the constant addressing mode. If the constant addressing mode is not supported, the similar logical transfer can be achieved using the increment (INCR) mode (EDMA_TPCC_OPT_n[0] SAM / EDMA_TPCC_OPT_n[1] DAM = 0) by appropriately programming the count and indices values.

11.2.3.3.9 Element Size

The EDMA controller does not use element-size and element-indexing. Instead, all transfers are defined in terms of all three dimensions: EDMA_TPCC_ABCNT_n[15:0] ACNT, EDMA_TPCC_ABCNT_n[31:16] BCNT, and EDMA_TPCC_CCNT_n[15:0] CCNT. An element-indexed transfer is logically achieved by programming EDMA_TPCC_ABCNT_n[15:0] ACNT to the size of the element and EDMA_TPCC_ABCNT_n[31:16] BCNT to the number of elements that need to be transferred. For example: If there are 16-bit audio data and 256 audio samples that must be transferred to a serial port, therefore the EDMA_TPCC_ABCNT_n[15:0] ACNT = 2 (2 bytes) and EDMA_TPCC_ABCNT_n[31:16] BCNT = 256.

11.2.3.4 Initiating a DMA Transfer

There are multiple ways to initiate a programmed data transfer using the EDMA_TPCC channel controller. Transfers on DMA channels are initiated by three sources.

They are listed as follows:

- **Event-triggered transfer request** (this is the typical usage of EDMA controller): A peripheral, system, or externally-generated event triggers a transfer request.
- **Manually-triggered transfer request:** The CPU manually triggers a transfer by writing a 1 to the corresponding bit in the event set registers (EDMA_TPCC_ESR / EDMA_TPCC_ESRH).
- **Chain-triggered transfer request:** A transfer is triggered on the completion of another transfer or sub-transfer.

Transfers on QDMA channels are initiated by two sources. They are as follows:

- **Auto-triggered transfer request:** Writing to the programmed trigger word triggers a transfer.
- **Link-triggered transfer requests:** Writing to the trigger word triggers the transfer when linking occurs.

11.2.3.4.1 DMA Channels

11.2.3.4.1.1 Event-Triggered Transfer Request

When an event is asserted from a peripheral or device pins, it gets latched in the corresponding bit of the event register (EDMA_TPCC_ER[31:0] $E_n = 1$). For more information about peripheral events to EDMA events mapping, refer to *the device data manual*.

If the corresponding event in the event enable register (EDMA_TPCC_EER) is enabled (EDMA_TPCC_EER[31:0] $E_n = 1$), then the EDMA_TPCC prioritizes and queues the event in the appropriate event queue. When the event reaches the head of the queue, it is evaluated for submission as a transfer request to the transfer controller.

If the PaRAM set is valid (not a NULL set), then a transfer request packet (TRP) is submitted to the EDMA_TPTC and the EDMA_TPCC_ER[31:0] E_n bit is cleared. At this point, a new event can be safely received by the EDMA_TPCC.

If the PaPARAM set associated with the channel is a NULL set (see [Section 11.2.3.3.3 Null PaPARAM Set](#)), then no transfer request (TR) is submitted and the corresponding EDMA_TPCC_ER[31:0] E_n bit is cleared and simultaneously the corresponding channel bit is set in the event miss register (EDMA_TPCC_EMR[31:0] $E_n = 1$)

to indicate that the event was discarded due to a null TR being serviced. Good programming practices should include cleaning the event missed error before re-triggering the DMA channel.

When an event is received, the corresponding event bit in the event register is set (EDMA_TPCC_ER[31:0] $E_n = 1$), regardless of the state of EDMA_TPCC_EER[31:0] E_n . If the event is disabled when an external event is received (EDMA_TPCC_ER[31:0] $E_n = 1$ and EDMA_TPCC_EER[31:0] $E_n = 0$), the EDMA_TPCC_ER[31:0] E_n bit remains set. If the event is subsequently enabled (EDMA_TPCC_EER[31:0] $E_n = 1$), then the pending event is processed by the EDMA_TPCC and the TR is processed/submitted, after which the EDMA_TPCC_ER[31:0] E_n bit is cleared.

If an event is being processed (prioritized or is in the event queue) and another sync event is received for the same channel prior to the original being cleared (EDMA_TPCC_ER[31:0] $E_n \neq 0$), then the second event is registered as a missed event in the corresponding bit of the event missed register (EDMA_TPCC_EMR[31:0] $E_n = 1$).

11.2.3.4.1.2 Manually-Triggered Transfer Request

The CPU or any peripheral device module initiates a DMA transfer by writing to the event set register EDMA_TPCC_ESR. Writing a 1 to an event bit in the EDMA_TPCC_ESR results in the event being prioritized/queued in the appropriate event queue, regardless of the state of the EDMA_TPCC_EER[31:0] E_n bit. When the event reaches the head of the queue, it is evaluated for submission as a transfer request to the transfer controller.

As in the event-triggered transfers, if the PaRAM set associated with the channel is valid (it is not a null set) then the TR is submitted to the associated EDMA_TPTC and the channel can be triggered again.

If the PaRAM set associated with the channel is a NULL set (see [Section 11.2.3.3.3 Null PaRAM Set](#)), then no transfer request (TR) is submitted and the corresponding EDMA_TPCC_ER[31:0] E_n bit is cleared and simultaneously the corresponding channel bit is set in the event miss register EDMA_TPCC_EMR[31:0] $E_n = 1$ to indicate that the event was discarded due to a null TR being serviced. Good programming practices should include clearing the event missed error before re-triggering the DMA channel.

If an event is being processed (prioritized or is in the event queue) and the same channel is manually set by a write to the corresponding channel bit of the event set register EDMA_TPCC_ESR[31:0] $E_n = 1$ prior to the original being cleared EDMA_TPCC_ESR[31:0] $E_n = 0$, then the second event is registered as a missed event in the corresponding bit of the event missed register EDMA_TPCC_EMR[31:0] $E_n = 1$.

11.2.3.4.1.3 Chain-Triggered Transfer Request

Chaining is a mechanism by which the completion of one transfer automatically sets the event for another channel. When a chained completion code is detected, the value of which is dictated by the transfer completion code EDMA_TPCC_OPT_n[17:12] TCC of the PaRAM set associated with the channel, it results in the corresponding bit in the chained event register EDMA_TPCC_CER to be set EDMA_TPCC_CER[31:0] $E[TCC] = 1$).

Once a bit is set in EDMA_TPCC_CER, the EDMA_TPCC prioritizes and queues the event in the appropriate event queue. When the event reaches the head of the queue, it is evaluated for submission as a transfer request to the transfer controller.

As in the event-triggered transfers, if the PaRAM set associated with the channel is valid (it is not a null set) then the TR is submitted to the associated EDMA_TPTC and the channel can be triggered again.

If the PaRAM set associated with the channel is a NULL set (see [Section 11.2.3.3.3 Null PaRAM Set](#)), then no transfer request (TR) is submitted and the corresponding EDMA_TPCC_CER[31:0] E_n bit is cleared and simultaneously the corresponding channel bit is set in the event miss register EDMA_TPCC_EMR[31:0] $E_n = 1$ to indicate that the event was discarded due to a null TR being serviced. In this case, the error condition must be cleared before the DMA channel can be re-triggered. Good programming practices might include clearing the event missed error before re-triggering the DMA channel.

If a chaining event is being processed (prioritized or queued) and another chained event is received for the same channel prior to the original being cleared EDMA_TPCC_CER[31:0] $E_n \neq 0$), then the second

chained event is registered as a missed event in the corresponding channel bit of the event missed register EDMA_TPCC_EMR[31:0] $En = 1$.

Note

Chained event registers EDMA_TPCC_CER, event registers EDMA_TPCC_ER, and event set registers EDMA_TPCC_ESR operate independently. An event En can be triggered by any of the trigger sources (event-triggered, manually-triggered, or chain-triggered).

11.2.3.4.2 QDMA Channels

11.2.3.4.2.1 Auto-Triggered and Link-Triggered Transfer Request

QDMA-based transfer requests are issued when a QDMA event gets latched in the QDMA event register EDMA_TPCC_QER[31:0] $En = 1$. A bit corresponding to a QDMA channel is set in the QDMA event register EDMA_TPCC_QER when the following occurs:

- A CPU (or any device module) write occurs to a PaRAM address that is defined as a QDMA channel trigger word (programmed in the QDMA channel mapping register EDMA_TPCC_QCHMAPN_j for the particular QDMA channel and the QDMA channel is enabled via the QDMA event enable register EDMA_TPCC_QEER[31:0] $En = 1$).
- EDMA_TPCC performs a link update on a PaRAM set address that is configured as a QDMA channel matches EDMA_TPCC_QCHMAPN_j settings and the corresponding channel is enabled via the QDMA event enable register EDMA_TPCC_QEER[31:0] $En = 1$.

Once a bit is set in EDMA_TPCC_QER, the EDMA_TPCC prioritizes and queues the event in the appropriate event queue. When the event reaches the head of the queue, it is evaluated for submission as a transfer request to the transfer controller.

As in the event-triggered transfers, if the PaRAM set associated with the channel is valid (it is not a null set) then the TR is submitted to the associated EDMA_TPTC and the channel can be triggered again.

If a bit is already set in EDMA_TPCC_QER[31:0] $En = 1$ and a second QDMA event for the same QDMA channel occurs prior to the original being cleared, the second QDMA event gets captured in the QDMA event miss register EDMA_TPCC_QEMR[7:0] $En = 1$.

11.2.3.4.3 Comparison Between DMA and QDMA Channels

The primary difference between DMA and QDMA channels is the event/channel synchronization.

QDMA events are either auto-triggered or link triggered. Auto-triggering allows QDMA channels to be triggered by CPU(s) with a minimum number of linear writes to PaRAM. Link triggering allows a linked list of transfers to be executed, using a single QDMA PaRAM set and multiple link PaRAM sets.

A QDMA transfer is triggered when a CPU (or other device modules) writes to the trigger word of the QDMA channel parameter set (auto-triggered) or when the EDMA_TPCC performs a link update on a PaRAM set that has been mapped to a QDMA channel (link triggered).

Note

The CPUs triggered (manually triggered) DMA channels, in addition to writing to the PaRAM set, it is required to write to the event set register EDMA_TPCC_ESR to kick-off the transfer.

QDMA channels are typically for cases where a single event accomplishes a complete transfer since the CPU (or other device modules) must reprogram some portion of the QDMA PaRAM set in order to re-trigger the channel. QDMA transfers are programmed with EDMA_TPCC_ABCNT_n[31:0] BCNT = 1 and EDMA_TPCC_CCNT_n[15:0] CCNT = 1 for A-synchronized transfers, and EDMA_TPCC_CCNT_n[15:0] CCNT = 1 for AB-synchronized transfers.

Additionally, since linking is also supported (if EDMA_TPCC_OPT_n[3] STATIC = 0) for QDMA transfers, it allows to initiate a linked list of QDMAs, so when EDMA_TPCC copies over a link PaRAM set (including the write

to the trigger word), the current PaRAM set mapped to the QDMA channel automatically recognizes as a valid QDMA event and initiate another set of transfers as specified by the linked set.

11.2.3.5 Completion of a DMA Transfer

A parameter set for a given channel is complete when the required number of transfer requests is submitted (based on receiving the number of synchronization events). The expected number of TRs for a non-null/non-dummy transfer is shown in [Table 11-11](#) for both synchronization types along with state of the PaRAM set prior to the final TR being submitted. When the counts (EDMA_TPCC_ABCNT_n[31:0] BCNT and/or EDMA_TPCC_CCNT_n[15:0] CCNT) are this value, the next TR results in:

- Final chaining or interrupt codes sent by the transfer controllers (instead of intermediate).
- Link updates (linking to either null or another valid link set).

Table 11-11. Expected Number of Transfers for Non-Null Transfer

Sync Mode	Counts at time 0	Total # Transfers	Counts prior to final TR
A-synchronized	ACNT BCNT CCNT	(BCNT × CCNT) TRs of ACNT bytes each	EDMA_TPCC_ABCNT_n[31:0] BCNT == 1 && EDMA_TPCC_CCNT_n[15:0] CCNT == 1
AB-synchronized	ACNT BCNT CCNT	CCNT TRs for ACNT × BCNT bytes each	EDMA_TPCC_CCNT_n[15:0] CCNT == 1

The PaRAM OPT field must program with a specific transfer completion code TCC or EDMA_TPCC_OPT_n[17:12] TCC along with the other EDMA_TPCC_OPT_n fields ([22] TCCHEN, [20] TCINTEN, [23] ITCCHEN, and [21] ITCINTEN bits) to indicate whether the completion code is to be used for generating a chained event or/and for generating an interrupt upon completion of a transfer.

The specific EDMA_TPCC_OPT_n[17:12] TCC value (6-bit binary value) programmed dictates which of the 64-bits in the chain event register EDMA_TPCC_CER [TCC] and/or interrupt pending register EDMA_TPCC_IPR [TCC] is set.

It can selectively program whether the transfer controller sends back completion codes on completion of the final transfer request (TR) of a parameter set EDMA_TPCC_OPT_n[22] TCCHEN or EDMA_TPCC_OPT_n[20] TCINTEN, for all but the final transfer request (TR) of a parameter set EDMA_TPCC_OPT_n[23] ITCCHEN or EDMA_TPCC_OPT_n[21] ITCINTEN), or for all TRs of a parameter set (both). Refer to [Section 11.2.3.8 Chaining EDMA Channels](#) for details on chaining (intermediate/final chaining) and [Section 11.2.3.9 EDMA Interrupts](#) for details on intermediate/final interrupt completion.

A completion detection interface exists between the EDMA channel controller and transfer controller(s). This interface sends back information from the transfer controller to the channel controller to indicate that a specific transfer is completed. Completion of a transfer is used for generating chained events and/or generating interrupts to the CPU(s).

All DMA/QDMA PaRAM sets must also specify a link address value. For repetitive transfers such as ping-pong buffers, the link address value must point to another predefined PaRAM set. Alternatively, a non-repetitive transfer must set the link address value to the null link value. The null link value is defined as FFFFh. Refer to [Section 11.2.3.3.7 Linking Transfers](#) for more details.

Note

Any incoming events that are mapped to a null PaRAM set results in an error condition. The error condition must clear before the corresponding channel is used again. Refer to [Section 11.2.3.3.5 Dummy Versus Null Transfer Comparison](#).

There are three ways the EDMA_TPCC gets updated/informed about a transfer completion: normal completion, early completion, and dummy/null completion. This applies to both chained events and completion interrupt generation.

11.2.3.5.1 Normal Completion

In normal completion mode EDMA_TPCC_OPT_n[11] TCCMODE = 0, the transfer or sub-transfer is considered to be complete when the EDMA channel controller receives the completion codes from the EDMA transfer controller. In this mode, the completion code to the channel controller is posted by the transfer controller after it receives a signal from the destination peripheral. Normal completion is typically used to generate an interrupt to inform the CPU that a set of data is ready for processing.

11.2.3.5.2 Early Completion

In early completion mode EDMA_TPCC_OPT_n[11] TCCMODE = 1, the transfer is considered to be complete when the EDMA channel controller submits the transfer request (TR) to the EDMA transfer controller. In this mode, the channel controller generates the completion code internally. Early completion is typically useful for chaining, as it allows subsequent transfers to be chained-triggered while the previous transfer is still in progress within the transfer controller, maximizing the overall throughput of the set of the transfers.

11.2.3.5.3 Dummy or Null Completion

This is a variation of early completion. Dummy or null completion is associated with a dummy set [Section 11.2.3.3.4](#) or null set [Section 11.2.3.3.3](#). In both cases, the EDMA channel controller does not submit the associated transfer request to the EDMA transfer controller(s). However, if the set (dummy/null) has the OPT field programmed to return completion code (intermediate/final interrupt/chaining completion), then it sets the appropriate bits in the interrupt pending registers EDMA_TPCC_IPR and EDMA_TPCC_IPRH or chained event register EDMA_TPCC_CER and EDMA_TPCC_CERH. The internal early completion path is used by the channel controller to return the completion codes internally (that is, EDMA_TPCC generates the completion code).

11.2.3.6 Event, Channel, and PaRAM Mapping

Several of the 64 DMA channels are tied to a specific hardware event, thus allowing events from device peripherals or external hardware (via the dma_evt[3:0] pins) to trigger transfers. A DMA channel typically requests a data transfer when it receives its event (apart from manually-triggered, chain-triggered, and other transfers). The amount of data transferred per synchronization event depends on the channel's configuration (EDMA_TPCC_ABCNT_n[15:0] ACNT, EDMA_TPCC_ABCNT_n[31:16] BCNT, EDMA_TPCC_CCNT_n[15:0] CCNT, etc.) and the synchronization type (A-synchronized or AB-synchronized).

The association of an event to a channel is fixed within the EDMA Channel Controller, that is, each DMA channel has one specific event associated with it.

In an application, if a channel does not use the associated synchronization event or if it does not have an associated synchronization event (unused), that channel can be used for manually-triggered or chained-triggered transfers, for linking/reloading, or as a QDMA channel.

11.2.3.6.1 DMA Channel to PaRAM Mapping

The mapping between the DMA channel numbers and the PaRAM sets is programmable (see). The DMA channel mapping registers EDMA_TPCC_DCHMAPN_m in the EDMA_TPCC provide programmability that allows the DMA channels to be mapped to any of the PaRAM sets in the PaRAM memory map. [Figure 11-11](#) illustrates the use of EDMA_TPCC_DCHMAPN_m. There is one EDMA_TPCC_DCHMAPN_m register per channel.

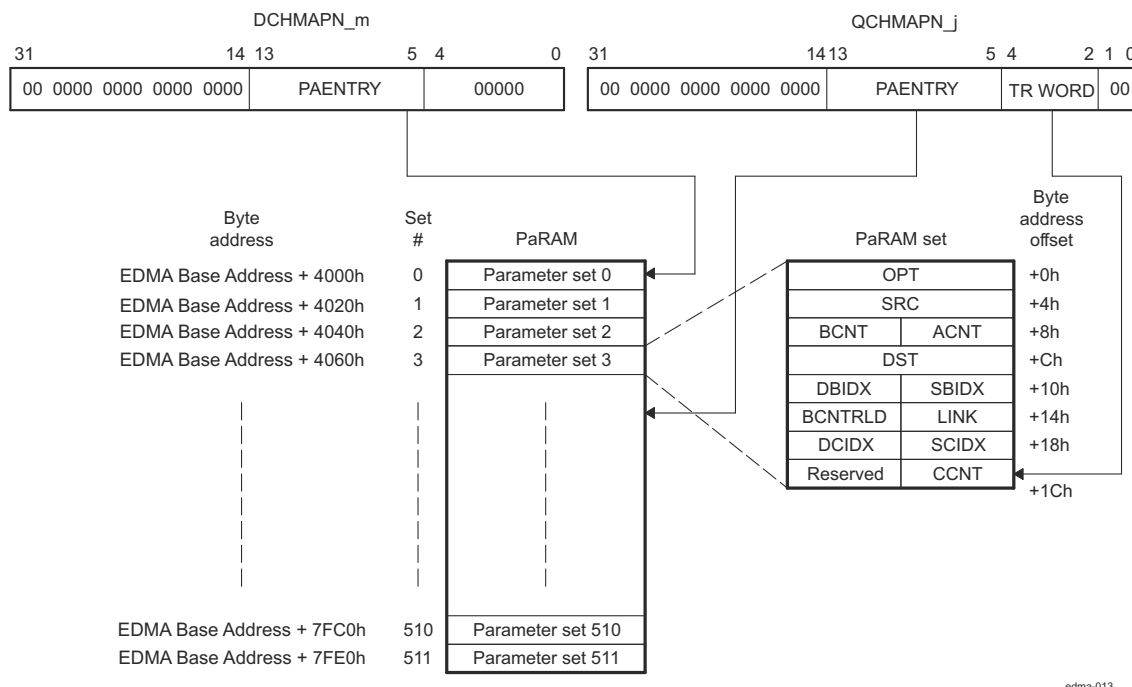

Figure 11-11. DMA Channel and QDMA Channel to PaRAM Mapping

Note

AM273x has a maximum of 128 PaRAM sets. Additional tables and diagrams in this chapter may show a larger number (up to 511), however 128 is the maximum allowed number of entries.

11.2.3.6.2 QDMA Channel to PaRAM Mapping

The mapping between the QDMA channels and the PaRAM sets is programmable. The QDMA channel mapping register **EDMA_TPCC_QCHMAPN_j** in the **EDMA_TPCC** allows to map the QDMA channels to any of the PaRAM sets in the PaRAM memory map. [Figure 11-12](#) illustrates the use of **EDMA_TPCC_QCHMAPN_j**.

EDMA_TPCC_QCHMAPN_j[4:2] **TRWORD** bit-field allows to program the trigger word in the PaRAM set for the QDMA channel. A trigger word is one of the eight words in the PaRAM set. For a QDMA transfer to occur, a valid TR synchronization event for **EDMA_TPCC** is a write to the trigger word in the PaRAM set pointed to by **EDMA_TPCC_QCHMAPN_j** for a particular QDMA channel. By default, QDMA channels are mapped to PaRAM set 0.

It must appropriately re-map PaRAM set 0 before use.

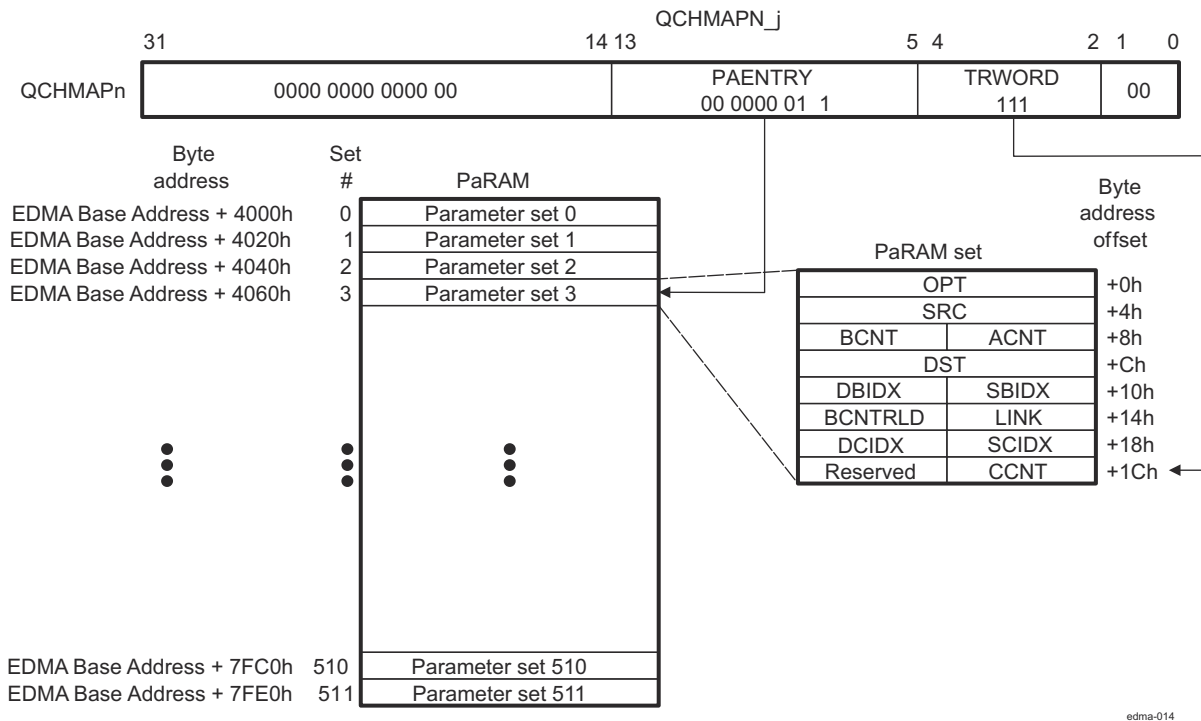

Figure 11-12. QDMA Channel to PaRAM Mapping

ADVANCE INFORMATION

edma-014

11.2.3.7 EDMA Channel Controller Regions

The EDMA channel controller divides its address space into eight regions. Individual channel resources are assigned to a specific region, where each region is typically assigned to a specific device module uses the EDMA controller.

Application software can use regions or to ignore them altogether. It can be used active memory protection in conjunction with regions so that only a specific device module which uses the EDMA (for example, privilege identification) or privilege level (for example, user vs. supervisor) is allowed access to a given region, and thus to a given DMA or QDMA channel. This allows robust system-level DMA code where each EDMA initiator only modifies the state of the assigned resources. Memory protection is described in [Section 11.2.3.10 Memory Protection](#).

11.2.3.7.1 Region Overview

The EDMA channel controller memory-mapped registers are divided in three main categories:

1. Global registers
2. Global region channel registers
3. Shadow region channel registers

The global registers are located at a single/fixed location in the EDMA_TPCC memory map. These registers control EDMA resource mapping and provide debug visibility and error tracking information.

The channel registers (including DMA, QDMA, and interrupt registers) are accessible via the global channel region address range, or in the shadow *n* channel region address range(s). For example, the event enable register EDMA_TPCC_EER is visible at the global address of EDMA Base Address + 1020h or region addresses of EDMA Base Address + 2020h for region 0, EDMA Base Address + 2220h for region 1, ... EDMA Base Address + 2E20h for region 7.

The DMA region access enable registers EDMA_TPCC_DRAEM_k and the QDMA region access enable registers EDMA_TPCC_QRAEN_k control the underlying control register bits that are accessible via the shadow region address space (except for EDMA_TPCC_IEVAL and EDMA_TPCC_IEVAL_RN_k registers). [Table 11-12](#)

lists the registers in the shadow region memory map. Refer to *EDMA_TPCC register mapping summary* for the complete global and shadow region memory maps.

Table 11-12. Shadow Region Registers

EDMA_TPCC_DRAE M_k	EDMA_TPCC_DRAE HM_k	EDMA_TPCC_QRAE N_k
EDMA_TPCC_ER	EDMA_TPCC_ERH	EDMA_TPCC_QER
EDMA_TPCC_ECR	EDMA_TPCC_ECRH	EDMA_TPCC_QEER
EDMA_TPCC_ESR	EDMA_TPCC_ESRH	EDMA_TPCC_QEER R
EDMA_TPCC_CER	EDMA_TPCC_CERH	EDMA_TPCC_QEES R
EDMA_TPCC_EER	EDMA_TPCC_EERH	
EDMA_TPCC_EECR	EDMA_TPCC_EECR H	
EDMA_TPCC_EESR	EDMA_TPCC_EESR H	
EDMA_TPCC_SER	EDMA_TPCC_SERH	
EDMA_TPCC_SECR	EDMA_TPCC_SECR H	
EDMA_TPCC_IER	EDMA_TPCC_IERH	
EDMA_TPCC_IECR	EDMA_TPCC_IECRH	
EDMA_TPCC_IESR	EDMA_TPCC_IESRH	
EDMA_TPCC_IPR	EDMA_TPCC_IPRH	
EDMA_TPCC_ICR	EDMA_TPCC_ICRH	
Register not affected by DRAE\DRAEH		
EDMA_TPCC_IEVAL		
EDMA_TPCC_IEVAL _RN_k		

Figure 11-13 illustrates the conceptual view of the regions.

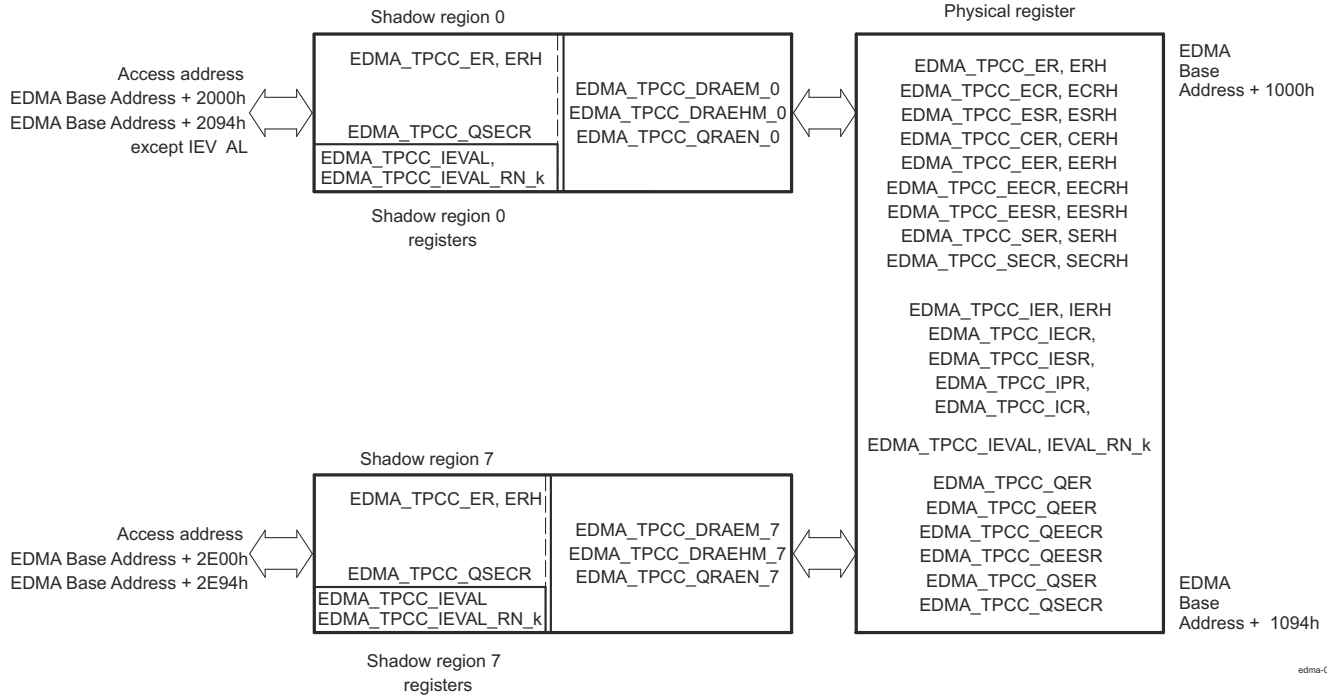

Figure 11-13. Shadow Region Registers

11.2.3.7.2 Channel Controller Regions

There are eight EDMA shadow regions (and associated memory maps). Associated with each shadow region are a set of registers defining which channels and interrupt completion codes belong to that region. These registers are user-programmed per region to assign ownership of the DMA/QDMA channels to a region.

- EDMATPCC_DRAEM_k and EDMATPCC_DRAEHM_k: One register pair exists for each of the shadow regions. The number of bits in each register pair matches the number of DMA channels (64 DMA channels). These registers need to be programmed to assign ownership of DMA channels and interrupt (or EDMATPCC_OPT_n[17:12] TCC codes) to the respective region. Accesses to DMA and interrupt registers via the shadow region address view are filtered through the DRAEM/DRAEHM pair. A value of 1 in the corresponding EDMATPCC_DRAEM_k[31:0] / EDMATPCC_DRAEHM_k[31:0] bit implies that the corresponding DMA interrupt channel is accessible; a value of 0 in the corresponding EDMATPCC_DRAEM_k[31:0] / EDMATPCC_DRAEHM_k[31:0] bit forces writes to be discarded and returns a value of 0 for reads.
- EDMATPCC_QRAEN_k: One register exists for every region. The number of bits in each register matches the number of QDMA channels (8 QDMA channels). These registers must be programmed to assign ownership of QDMA channels to the respective region. To enable a channel in a shadow region using shadow region 0 EDMATPCC_QEER, the corresponding bits in QRAE must be set or writing into EDMATPCC_QEESR there will be no the desired effect.
- EDMATPCC_MPPAN_k and EDMATPCC_MPPAG: One register exists for every region. This register defines the privilege level, requestor, and types of accesses allowed to a region's memory-mapped registers.

It is typical for an application to have a unique assignment of QDMA/DMA channels (and, therefore, a given bit position) to a given region.

The use of shadow regions allows restricted access to EDMA resources (DMA channels, QDMA channels, TCC, interrupts) by tasks in a system by setting or clearing bits in the EDMATPCC_DRAEM_k / EDMATPCC_QRAEN_k registers.

If exclusive access to any given channel / TCC code is required for a region, then only that region's EDMATPCC_DRAEM_k / EDMATPCC_QRAEN_k have the associated bit set.

edma-015

Example 11-1. Resource Pool Division Across Two Regions

This example illustrates a resource pool division across two regions, assuming region 0 must be allocated 16 DMA channels (0-15) and 1 QDMA channel (0) and 32 TCC codes (0-15 and 48-63).

Region 1 needs to be allocated 16 DMA channels (16-32) and the remaining 7 QDMA channels (1-7) and TCC codes (16-47).

EDMA_TPCC_DRAEM_k should be equal to the OR of the bits that are required for the DMA channels and the TCC codes:

```
Region 0: DRAEHM, DRAEM = 0xFFFF0000, 0x0000FFFF QRAEN = 0x0000001
Region 1: DRAEHM, DRAEM = 0x0000FFFF, 0xFFFF0000 QRAEN = 0x00000FE
```

11.2.3.7.3 Region Interrupts

In addition to the EDMA_TPCC global completion interrupt, there is an additional completion interrupt line that is associated with every shadow region. Along with the interrupt enable register EDMA_TPCC_IER, DRAEM acts as a secondary interrupt enable for the respective shadow region interrupts. Refer to *Hardware Request* for more information about EDMA Interrupts.

11.2.3.8 Chaining EDMA Channels

The channel chaining capability for the EDMA allows the completion of an EDMA channel transfer to trigger another EDMA channel transfer. The purpose is to allow the ability to chain several events through one event occurrence.

Chaining is different from linking ([Section 11.2.3.3.7 Linking Transfers](#)). The EDMA link feature reloads the current channel parameter set with the linked parameter set. The EDMA chaining feature does not modify or update any channel parameter set. It provides a synchronization event to the chained channel (see [Section 11.2.3.4.1.3 Chain-Triggered Transfer Request](#)).

Chaining is achieved at either final transfer completion or intermediate transfer completion, or both, of the current channel. Consider a channel m (DMA/QDMA) required to chain to channel n . Channel number n (0-63) needs to be programmed into the EDMA_TPCC_OPT_n[17:12] TCC bit-field of channel m channel options parameter (OPT) set.

- If final transfer completion chaining EDMA_TPCC_OPT_n[22] TCCHEN = 1 is enabled, the chain-triggered event occurs after the submission of the last transfer request of channel m is either submitted or completed (depending on early or normal completion).

- If intermediate transfer completion chaining EDMA_TPCC_OPT_n[23] ITCCHEN = 1 is enabled, the chain-triggered event occurs after every transfer request, except the last of channel *m* is either submitted or completed (depending on early or normal completion).
- If both final and intermediate transfer completion chaining (EDMA_TPCC_OPT_n[22] TCCHEN = 1 and EDMA_TPCC_OPT_n[23] ITCCHEN = 1) are enabled, then the chain-trigger event occurs after every transfer request is submitted or completed (depending on early or normal completion).

Table 11-13 illustrates the number of chain event triggers occurring in different synchronized scenarios. Consider channel 31 programmed with EDMA_TPCC_ABCNT_n[15:0] ACNT = 3, EDMA_TPCC_ABCNT_n[31:16] BCNT = 4, EDMA_TPCC_CCNT_n[15:0] CCNT = 5, and EDMA_TPCC_OPT_n[17:12] TCC = 30.

Table 11-13. Chain Event Triggers

Options	(Number of chained event triggers on channel 30)	
	A-Synchronized	AB-Synchronized
EDMA_TPCC_OPT_n[22] TCCHEN = 1, EDMA_TPCC_OPT_n[23] ITCCHEN = 0	1 (Owing to the last TR)	1 (Owing to the last TR)
EDMA_TPCC_OPT_n[22] TCCHEN = 0, EDMA_TPCC_OPT_n[23] ITCCHEN = 1	19 (Owing to all but the last TR)	4 (Owing to all but the last TR)
EDMA_TPCC_OPT_n[22] TCCHEN = 1, EDMA_TPCC_OPT_n[23] ITCCHEN = 1	20 (Owing to a total of 20 TRs)	5 (Owing to a total of 5 TRs)

11.2.3.9 EDMA Interrupts

The EDMA interrupts are divided into 2 categories: transfer completion interrupts and error interrupts.

There are nine region interrupts, eight shadow regions and one global region. The transfer completion interrupts are listed in Table 11-14. The transfer completion interrupts and the error interrupts from the transfer controllers are all routed to the device interrupt controllers INTCs.

Table 11-14. EDMA Transfer Completion Interrupts

Name	Description
EDMA_TPCC_INT0	EDMA_TPCC Transfer Completion Interrupt Shadow Region 0
EDMA_TPCC_INT1	EDMA_TPCC Transfer Completion Interrupt Shadow Region 1
EDMA_TPCC_INT2	EDMA_TPCC Transfer Completion Interrupt Shadow Region 2
EDMA_TPCC_INT3	EDMA_TPCC Transfer Completion Interrupt Shadow Region 3
EDMA_TPCC_INT4	EDMA_TPCC Transfer Completion Interrupt Shadow Region 4
EDMA_TPCC_INT5	EDMA_TPCC Transfer Completion Interrupt Shadow Region 5
EDMA_TPCC_INT6	EDMA_TPCC Transfer Completion Interrupt Shadow Region 6
EDMA_TPCC_INT7	EDMA_TPCC Transfer Completion Interrupt Shadow Region 7

Table 11-15. EDMA Error Interrupts

Name	Description
EDMA_TPCC_ERRINT	EDMA_TPCC Error Interrupt
EDMA_TPCC_MPINT	EDMA_TPCC Memory Protection Interrupt
EDMA_TC0_ERRINT	TC0 Error Interrupt
EDMA_TC1_ERRINT	TC1 Error Interrupt

11.2.3.9.1 Transfer Completion Interrupts

The EDMA_TPCC is responsible for generating transfer completion interrupts to the CPU(s) (and other EDMA controllers). The EDMA generates a single completion interrupt per shadow region, as well as one for the global region on behalf of all 64 channels. The various control registers and bit fields facilitate EDMA interrupt generation.

The software architecture must either use the global interrupt or the shadow interrupts, but not both.

The transfer completion code EDMA_TPCC_OPT_n[17:12] TCC value is directly mapped to the bits of the interrupt pending register EDMA_TPCC_IPR / EDMA_TPCC_IPRH.

For example, if EDMA_TPCC_OPT_n[17:12] TCC = 10 0001b, EDMA_TPCC_IPRH[1] is set after transfer completion, and results in interrupt generation to the CPU(s) if the completion interrupt is enabled for the CPU. See [Section 11.2.3.9.1.1 Enabling Transfer Completion Interrupts](#) for details about enabling EDMA transfer completion interrupts.

When a completion code is returned (as a result of early or normal completions), the corresponding bit in EDMA_TPCC_IPR / EDMA_TPCC_IPRH registers is set if transfer completion interrupt (final/intermediate) is enabled in the channel options parameter (OPT) for a PaRAM set associated with the transfer.

Table 11-16. Transfer Complete Code (TCC) to EDMA_TPCC Interrupt Mapping

TCC values in EDMA_TPCC_OPT_n[17:12] TCC (EDMA_TPCC_OPT_n[20] TCINTEN / EDMA_TPCC_OPT_n[21] ITCINTEN = 1)	EDMA_TPCC_IPR Bit Set	TCC values in EDMA_TPCC_OPT_n[17:12] TCC (EDMA_TPCC_OPT_n[20] TCINTEN / EDMA_TPCC_OPT_n[21] ITCINTEN = 1)	EDMA_TPCC_IPRH Bit Set ⁽¹⁾
0	EDMA_TPCC_IPR[0]	20h	EDMA_TPCC_IPR[32] / EDMA_TPCC_IPRH[0]
1	EDMA_TPCC_IPR[1]	21h	EDMA_TPCC_IPR[33] / EDMA_TPCC_IPRH[1]
2h	EDMA_TPCC_IPR[2]	22h	EDMA_TPCC_IPR[34] / EDMA_TPCC_IPRH[2]
3h	EDMA_TPCC_IPR[3]	23h	EDMA_TPCC_IPR[35] / EDMA_TPCC_IPRH[3]
4h	EDMA_TPCC_IPR[4]	24h	EDMA_TPCC_IPR[36] / EDMA_TPCC_IPRH[4]
...
1Eh	EDMA_TPCC_IPR[30]	3Eh	EDMA_TPCC_IPR[62] / EDMA_TPCC_IPRH[30]
1Fh	EDMA_TPCC_IPR[31]	3Fh	EDMA_TPCC_IPR[63] / EDMA_TPCC_IPRH[31]

(1) Bit fields EDMA_TPCC_IPR [32-63] correspond to bits 0 to 31 in EDMA_TPCC_IPRH, respectively.

The transfer completion code (TCC) can program to any value for a DMA/QDMA channel. A direct relation between the channel number and the transfer completion code value does not need to exist. This allows multiple channels having the same transfer completion code value to cause a CPU to execute the same interrupt service routine (ISR) for different channels.

If the channel is used in the context of a shadow region and it intends for the shadow region interrupt to be asserted, then ensure that the bit corresponding to the TCC code is enabled in EDMA_TPCC_IER / EDMA_TPCC_IERH and in the corresponding shadow region's DMA region access registers (EDMA_TPCC_DRAEM_k / EDMA_TPCC_DRAEHM_k).

Interrupt generation can be enabled at either final transfer completion or intermediate transfer completion, or both. Consider channel *m* as an example.

- If the final transfer interrupt (EDMA_TPCC_OPT_n[20] TCINTEN = 1) is enabled, the interrupt occurs after the last transfer request of channel *m* is either submitted or completed (depending on early or normal completion).
- If the intermediate transfer interrupt (EDMA_TPCC_OPT_n[21] ITCINTEN = 1) is enabled, the interrupt occurs after every transfer request, except the last TR of channel *m* is either submitted or completed (depending on early or normal completion).
- If both final and intermediate transfer completion interrupts (EDMA_TPCC_OPT_n[20] TCINTEN = 1, and EDMA_TPCC_OPT_n[21] ITCINTEN = 1) are enabled, then the interrupt occurs after every transfer request is submitted or completed (depending on early or normal completion).

Table 11-17 shows the number of interrupts that occur in different synchronized scenarios. Consider channel 31, programmed with ABCNT_n[15:0] ACNT = 3, EDMA_TPCC_ABCNT_n[31:16] BCNT = 4, EDMA_TPCC_CCNT_n[15:0]CCNT = 5, and EDMA_TPCC_OPT_n[17:12] TCC = 30.

Table 11-17. Number of Interrupts

Options	A-Synchronized	AB-Synchronized
EDMA_TPCC_OPT_n[20] TCINTEN = 1, EDMA_TPCC_OPT_n[21] ITCINTEN = 0	1 (Last TR)	1 (Last TR)
EDMA_TPCC_OPT_n[20] TCINTEN = 0, EDMA_TPCC_OPT_n[21] ITCINTEN = 1	19 (All but the last TR)	4 (All but the last TR)
EDMA_TPCC_OPT_n[20] TCINTEN = 1, EDMA_TPCC_OPT_n[21] ITCINTEN = 1	20 (All TRs)	5 (All TRs)

11.2.3.9.1 Enabling Transfer Completion Interrupts

For the EDMA channel controller to assert a transfer completion to the external environment, the interrupts must be enabled in the EDMA_TPCC. This is in addition to setting up the EDMA_TPCC_OPT_n[20] TCINTEN and EDMA_TPCC_OPT_n[21] ITCINTEN bits of the associated PaRAM set.

The EDMA channel controller has interrupt enable registers EDMA_TPCC_IER / EDMA_TPCC_IERH and each bit location in EDMA_TPCC_IER / EDMA_TPCC_IERH serves as a primary enable for the corresponding interrupt pending registers EDMA_TPCC_IPR / EDMA_TPCC_IPRH.

All of the interrupt registers (EDMA_TPCC_IER, EDMA_TPCC_IESR, EDMA_TPCC_IECR, and EDMA_TPCC_IPR) are either manipulated from the global DMA channel region, or by the DMA channel shadow regions. The shadow regions provide a view to the same set of physical registers that are in the global region.

The EDMA channel controller has a hierarchical completion interrupt scheme that uses a single set of interrupt pending registers EDMA_TPCC_IPR / EDMA_TPCC_IPRH and single set of interrupt enable registers EDMA_TPCC_IER / EDMA_TPCC_IERH. The programmable DMA region access enable registers EDMA_TPCC_DRAEM_k / EDMA_TPCC_DRAEHM_k provides a second level of interrupt masking. The global region interrupt output is gated based on the enable mask that is provided by EDMA_TPCC_IER / EDMA_TPCC_IERH, see [Figure 11-14](#)

The region interrupt outputs are gated by EDMA_TPCC_IER and the specific EDMA_TPCC_DRAEM_k / EDMA_TPCC_DRAEHM_k associated with the region.

[Figure 11-14](#) shows the Interrupt diagram of the EDMA controller.

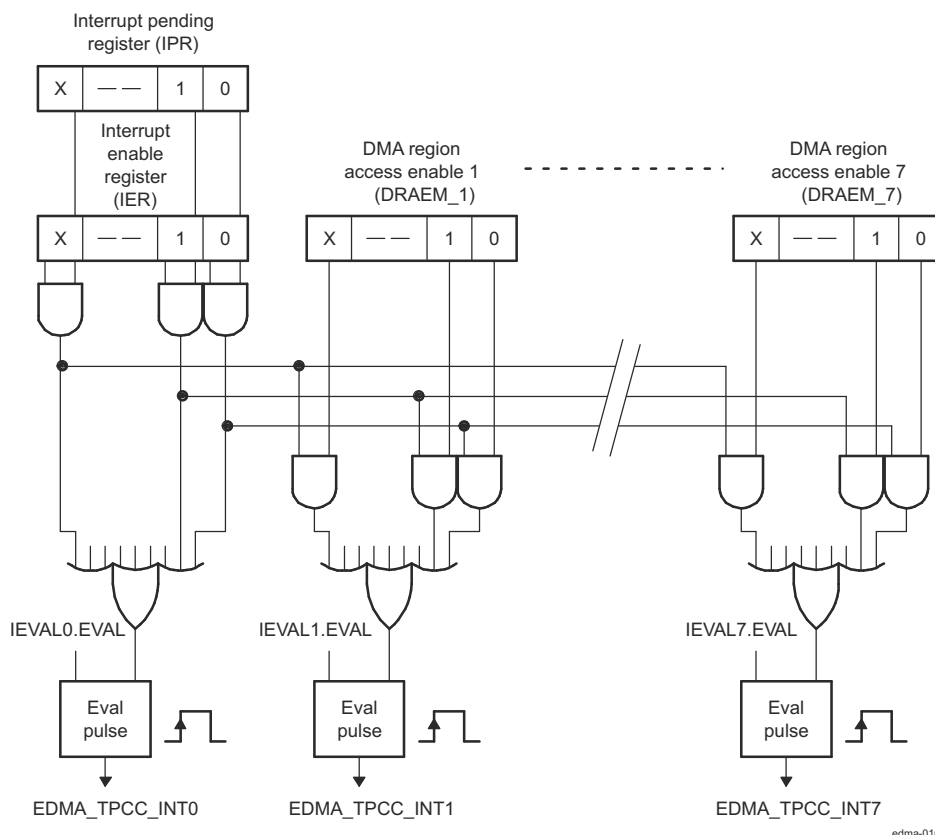

Figure 11-14. Interrupt Diagram

The EDMA_TPCC generates the transfer completion interrupts that are associated with each shadow region, the following conditions must be true:

- EDMA_TPCC_INT0: (EDMA_TPCC_IPR[0] E0 & EDMA_TPCC_IER[0] E0 & EDMA_TPCC_DRAEM_k.DRAEM_0[0] E0) | (EDMA_TPCC_IPR[1] E1 & EDMA_TPCC_IER[1] E1 & EDMA_TPCC_DRAEM_k.DRAEM_0[1] E1) | ...|(EDMA_TPCC_IPRH[31] E63 & EDMA_TPCC_IERH[31] E63 & EDMA_TPCC_DRAEHM_k.DRAEHM_0[31] E63)
- EDMA_TPCC_INT1: (EDMA_TPCC_IPR[0] E0 & EDMA_TPCC_IER[0] E0 & EDMA_TPCC_DRAEM_k.DRAEM_1[0] E0) | (EDMA_TPCC_IPR[1] E1 & EDMA_TPCC_IER[1] E1 & EDMA_TPCC_DRAEM_k.DRAEM_1[1] E1) | ...| (EDMA_TPCC_IPRH[31] E63 & EDMA_TPCC_IERH[31] E63 & EDMA_TPCC_DRAEHM_k.DRAEHM_1[31] E63)
- EDMA_TPCC_INT2: (EDMA_TPCC_IPR[0] E0 & EDMA_TPCC_IER[0] E0 & EDMA_TPCC_DRAEM_k.DRAEM_2[0] E0) | (EDMA_TPCC_IPR[1] E1 & EDMA_TPCC_IER[1] E1 & EDMA_TPCC_DRAEM_k.DRAEM_2[1] E1) | ...|(EDMA_TPCC_IPRH[31] E63 & EDMA_TPCC_IERH[31] E63 & EDMA_TPCC_DRAEHM_k.DRAEHM_2[31] E63)....
- Up to EDMA_TPCC_INT7: (EDMA_TPCC_IPR[0] E0 & EDMA_TPCC_IER[0] E0 & EDMA_TPCC_DRAEM_k.DRAEM_7[0] E0) | (EDMA_TPCC_IPR[1] E1 & EDMA_TPCC_IER[1] E1 & EDMA_TPCC_DRAEM_k.DRAEM_7[1] E1) | ...|(EDMA_TPCC_IPRH[31] E63 & EDMA_TPCC_IERH[31] E63 & EDMA_TPCC_DRAEHM_k.DRAEHM_7[31] E63)

Note

The EDMA_TPCC_DRAEM_k / EDMA_TPCC_DRAEHM_k for all regions are expected to be set up at system initialization and to remain static for an extended period of time. The interrupt enable registers are used for dynamic enable/disable of individual interrupts.

Because there is no relation between the EDMA_TPCC_OPT_n[17:12] TCC value and the DMA/QDMA channel, it is possible, the DMA channel 0 to have the EDMA_TPCC_OPT_n[17:12] TCC = 63 in its associated PaRAM set. This means that if a transfer completion interrupt is enabled (EDMA_TPCC_OPT_n[20] TCINTEN or EDMA_TPCC_OPT_n[21] ITCINTEN is set), then based on the TCC value, EDMA_TPCC_IPRH[31] E63 is set up on completion. For proper channel operations and interrupt generation using the shadow region map - program the EDMA_TPCC_DRAEM_k / EDMA_TPCC_DRAEHM_k that is associated with the shadow region to have read/write access to both bit 0 (corresponding to channel 0) and bit 63 (corresponding to EDMA_TPCC_IPRH bit that is set upon completion).

11.2.3.9.1.2 Clearing Transfer Completion Interrupts

Transfer completion interrupts that are latched to the interrupt pending registers (EDMA_TPCC_IPR / EDMA_TPCC_IPRH) are cleared by writing a 1 to the corresponding bit in the interrupt pending clear register (EDMA_TPCC_ICR / EDMA_TPCC_ICRH). For example, a write of 1 to EDMA_TPCC_ICR[0] E0 clears a pending interrupt in EDMA_TPCC_IPR[0] E0.

If an incoming transfer completion code TCC (EDMA_TPCC_OPT_n[17:12] TCC) gets latched to a bit in EDMA_TPCC_IPR / EDMA_TPCC_IPRH, then additional bits that get set due to a subsequent transfer completion does not result in asserting the EDMA_TPCC completion interrupt. In order for the completion interrupt to be pulsed, the required transition is from a state where no enabled interrupts are set to a state where at least one enabled interrupt is set.

11.2.3.9.2 EDMA Interrupt Servicing

Upon completion of a transfer (early or normal completion), the EDMA channel controller sets the appropriate bit in the interrupt pending registers (EDMA_TPCC_IPR / EDMA_TPCC_IPRH), as the transfer completion codes specify. If the completion interrupts are appropriately enabled, then the CPU enters the interrupt service routine (ISR) when the completion interrupt is asserted.

After servicing the interrupt, the ISR should clear the corresponding bit in EDMA_TPCC_IPR/ EDMA_TPCC_IPRH, thereby enabling recognition of future interrupts. The EDMA_TPCC only asserts additional completion interrupts when all EDMA_TPCC_IPR / EDMA_TPCC_IPRH bits clear.

When one interrupt is serviced many other transfer completions may result in additional bits being set in EDMA_TPCC_IPR / EDMA_TPCC_IPRH, thereby resulting in additional interrupts. Each of the bits in EDMA_TPCC_IPR / EDMA_TPCC_IPRH may need different types of service therefore, the ISR must check all pending interrupts and continue until all of the posted interrupts are serviced appropriately.

Examples of pseudo code for a CPU interrupt service routine for an EDMA_TPCC completion interrupt are shown in [Example 11-2](#) and [Example 11-3](#).

The ISR routine in [Example 11-2](#) is more exhaustive and incurs a higher latency.

Example 11-2. Interrupt Servicing

The pseudo code:

1. Reads the interrupt pending register EDMA_TPCC_IPR / EDMA_TPCC_IPRH.
2. Performs the operations needed.
3. Writes to the interrupt pending clear register EDMA_TPCC_ICR / EDMA_TPCC_ICRH to clear the corresponding EDMA_TPCC_IPR / EDMA_TPCC_IPRH bit(s).
4. Reads EDMA_TPCC_IPR / EDMA_TPCC_IPRH again:

- a. If EDMA_TPCC_IPR / EDMA_TPCC_IPRH is not equal to 0, repeat from step 2 (implies occurrence of new event between step 2 to step 4).
- b. If EDMA_TPCC_IPR / EDMA_TPCC_IPRH is equal to 0, assure that all of the enabled interrupts are inactive.

Note

An event may occur during step 4 while the EDMA_TPCC_IPR / EDMA_TPCC_IPRH bits are read as 0 and the application is still in the interrupt service routine. If this happens, a new interrupt is recorded in the device interrupt controller and a new interrupt generates as soon as the application exits in the interrupt service routine.

11.2.3.9.3

Example 11-3 is less rigorous, with less burden on the software in polling for set interrupt bits, but can occasionally cause a race condition as mentioned above.

Example 11-3. Interrupt Servicing

If any enabled and pending (possibly lower priority) interrupts are left, force the interrupt logic to reassert the interrupt pulse by setting the EDMA_TPCC_IEVAL[0] EVAL bit in the interrupt evaluation register.

The pseudo code is as follows:

1. Enters ISR.
2. Reads EDMA_TPCC_IPR / EDMA_TPCC_IPRH.
3. For the condition that is set in EDMA_TPCC_IPR / EDMA_TPCC_IPRH:
 - a. Service interrupt as the application requires.
 - b. Clear the bit for serviced conditions (others may still be set, and other transfers may have resulted in returning the TCC to EDMA_TPCC after step 2).
4. Reads EDMA_TPCC_IPR / EDMA_TPCC_IPRH prior to exiting the ISR:
 - a. If EDMA_TPCC_IPR / EDMA_TPCC_IPRH is equal to 0, then exit the ISR.
 - b. If EDMA_TPCC_IPR / EDMA_TPCC_IPRH is not equal to 0, then set EDMA_TPCC_IEVAL so that upon exit of ISR, a new interrupt triggers if any enabled interrupts are still pending.

11.2.3.9.4 Interrupt Evaluation Operations

The EDMA_TPCC has interrupt evaluate registers EDMA_TPCC_IEVAL that exist in the global region and in each shadow region. The registers in the shadow region are the only registers in the DMA channel shadow region memory map that are not affected by the settings for the DMA region access enable registers EDMA_TPCC_DRAEM_k / EDMA_TPCC_DRAEHM_k. Writing a 1 to the EDMA_TPCC_IEVAL[0] EVAL bit in the registers that are associated with a particular shadow region results in pulsing the associated region interrupt (global or shadow), if any enabled interrupt (via EDMA_TPCC_IER / EDMA_TPCC_IERH) is still pending EDMA_TPCC_IPR / EDMA_TPCC_IPRH. This register assures that the CPU does not miss the interrupts (or the EDMA controller associated with the shadow region) if the software architecture chooses not to use all interrupts. Refer to [Example 11-3](#) about the use of EDMA_TPCC_IEVAL in the EDMA interrupt service routine (ISR).

Similarly an error evaluation register EDMA_TPCC_EEVAL exists in the global region. Writing a 1 to the EDMA_TPCC_EEVAL[0] EVAL bit causes the pulsing of the error interrupt if any pending errors are in EDMA_TPCC_EMR / EDMA_TPCC_EMRH, EDMA_TPCC_QEMR, or EDMA_TPCC_CCERR. See [Section 11.2.3.9.5 Error Interrupts](#) for additional information regarding error interrupts.

Note

While using EDMA_TPCC_IEVAL for shadow region completion interrupts, check that the EDMA_TPCC_IEVAL operated upon is from that particular shadow region memory map.

11.2.3.9.5 Error Interrupts

The EDMA_TPCC error registers provide the capability to differentiate error conditions (event missed, threshold exceed, etc.). Additionally, setting the error bits in these registers results in asserting the EDMA_TPCC error interrupt. If the EDMA_TPCC error interrupt is enabled in the device interrupt controller(s), then it allows the CPU(s) to handle the error conditions.

The EDMA_TPCC has a single error interrupt (EDMA_TPCC_ERRINT) that is asserted for all EDMA_TPCC error conditions. There are four conditions that cause the error interrupt:

- DMA missed events: for all 64 DMA channels. DMA missed events are latched in the event missed registers EDMA_TPCC_EMR / EDMA_TPCC_EMRH.
- QDMA missed events: for all 8 QDMA channels. QDMA missed events are latched in the QDMA event missed register EDMA_TPCC_QEMR.
- Threshold exceed: for all event queues. These are latched in EDMA_TPCC error register EDMA_TPCC_CCERR.
- TCC error: for outstanding transfer requests that are expected to return completion code EDMA_TPCC_OPT_n[22] TCCHEN or EDMA_TPCC_OPT_n[23] TCINTEN bit is set to 1, exceeding the maximum limit of 63. This is also latched in the EDMA_TPCC error register EDMA_TPCC_CCERR.

Figure 11-15 illustrates the EDMA_TPCC error interrupt generation operation.

If any of the bits are set in the error registers due to any error condition, the EDMA_TPCC_ERRINT is always asserted, as there are no enables for masking these error events. Similar to transfer completion interrupts (EDMA_TPCC_INT), the error interrupt also only pulses when the error interrupt condition transitions from no errors being set to at least one error being set. If additional error events are latched prior to the original error bits clearing, the EDMA_TPCC does not generate additional interrupt.

To reduce the burden on the software, there is an error evaluate register EDMA_TPCC_EEVAL that allows re-evaluation of pending set error events/bits, similar to the interrupt evaluate register EDMA_TPCC_IEVAL. Unlike the EDMA_TPCC_IEVAL functionality, the EDMA_TPCC_EEVAL register must be written with '1' after any error interrupts are serviced (even when all pending errors are cleared) in order for subsequent errors to trigger a new interrupt.

Note

It is good practice to enable the error interrupt in the device interrupt controller and to associate an interrupt service routine with it to address the various error conditions appropriately. Doing so puts less burden on the software (polling for error status), it provides a good debug mechanism for unexpected error conditions.

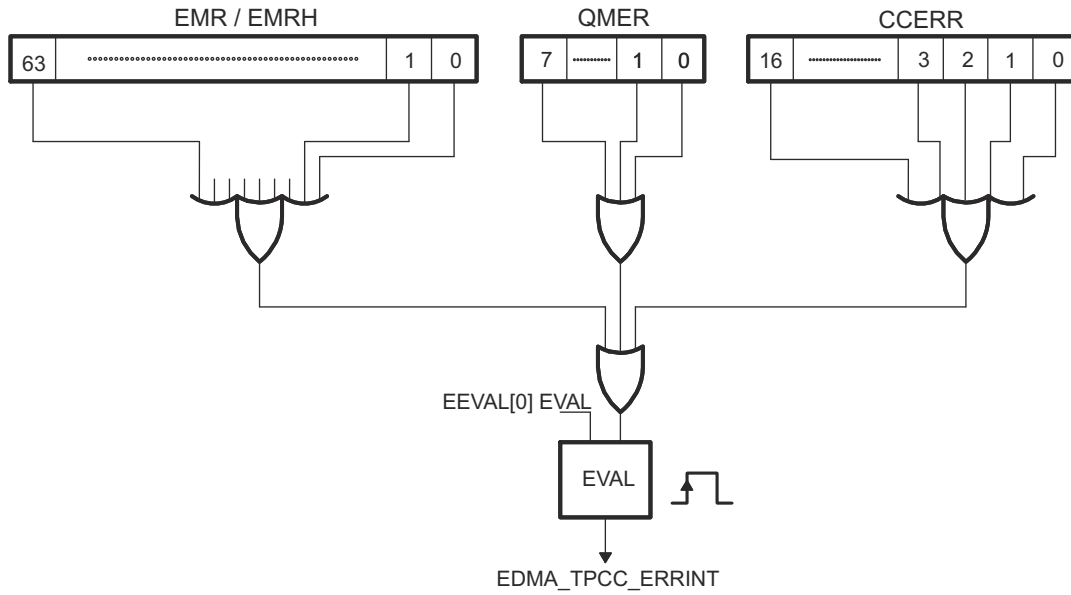

edma-017

Figure 11-15. Error Interrupt Operation

11.2.3.10 Memory Protection

The EDMA channel controller supports two kinds of memory protection: active and proxy.

11.2.3.10.1 Active Memory Protection

Active memory protection is a feature that allows or prevents read and write accesses to the EDMA_TPCC registers. Active memory protection is achieved by a set of memory protection permissions attribute EDMA_TPCC_MPPAN_k registers.

The EDMA_TPCC register map is divided into three categories:

- a global region.
- a global channel region.
- eight shadow regions.

Each shadow region consists of the respective shadow region registers and the associated PaRAM. For more detailed information regarding the contents of a shadow region, refer to the associated Register Addendum.

Each of the eight shadow regions has an associated EDMA_TPCC_MPPAN_k registers that defines the specific requestor(s) and types of requests that are allowed to the regions resources.

The global channel region is also protected with a memory-mapped register EDMA_TPCC_MPPAG. The EDMA_TPCC_MPPAG applies to the global region and to the global channel region, except the other EDMA_TPCC_MPPAN_k registers themselves.

Table 11-18 shows the accesses that are allowed or not allowed to the EDMA_TPCC_MPPAG and EDMA_TPCC_MPPAN_k. The active memory protection uses the EDMA_TPCC_OPT_n[31] PRIV and EDMA_TPCC_OPT_n[27:24] PRIVID attributes of the EDMA peripheral modules. The EDMA_TPCC_OPT_n[31] PRIV is the privilege level (i.e., user vs. supervisor).

The EDMA_TPCC_OPT_n[27:24] PRIVID refers to a privilege ID with a number that is associated with an EDMA peripheral modules.

Table 11-18. Allowed Accesses

Access	Supervisor	User
Read	Yes	Yes
Write	Yes	No

Table 11-19 describes the EDMA_TPCC_MPPAN_k register mapping for the shadow regions (which includes shadow region registers and PaRAM addresses).

The region-based EDMA_TPCC_MPPAN_k registers are used to protect accesses to the DMA shadow regions and the associated region PaRAM. Because there are eight regions, there are eight EDMA_TPCC_MPPAN_k region registers (MPPA[0-7]).

Table 11-19. MPPA Registers to Region Assignment

Register	Registers Protect	Address Range	PaRAM Protect ⁽¹⁾	Address Range
EDMA_TPCC_MPPAG	Global Range	0000h-1FFCh	N/A	N/A
EDMA_TPCC_MPPAN_k. MPPAN_0	DMA Shadow 0	2000h-21FCh	1st octant	4000h-47FCh
MPPAN_1	DMA Shadow 1	2200h-23FCh	2nd octant	4800h-4FFCh
MPPAN_2	DMA Shadow 2	2400h-25FCh	3rd octant	5000h-57FCh
MPPAN_3	DMA Shadow 3	2600h-27FCh	4th octant	5800h-5FFCh
MPPAN_4	DMA Shadow 4	2800h-29FCh	5th octant	6000h-67FCh
MPPAN_5	DMA Shadow 5	2A00h-2BFCh	6th octant	6800h-6FFCh
MPPAN_6	DMA Shadow 6	2C00h-2DFCh	7th octant	7000h-77FCh
MPPAN_7	DMA Shadow 7	2E00h-2FFCh	8th octant	7800h-7FFCh

(1) The PARAM region is divided into 8 regions referred to as an octant.

Example Access denied.

Write access to shadow region 7's event enable set register EDMA_TPCC_EESR:

1. The original value of the event enable register EDMA_TPCC_EER at address offset 0x1020 is 0x0.
2. The EDMA_TPCC_MPPAN_k. EDMA_TPCC_MPPAN_7[7] NS is set to prevent user level accesses (EDMA_TPCC_MPPAN_k. EDMA_TPCC_MPPAN_7[1] UW = 0, EDMA_TPCC_MPPAN_k. EDMA_TPCC_MPPAN_7[2] UR = 0), but it allows supervisor level accesses (EDMA_TPCC_MPPAN_k. EDMA_TPCC_MPPAN_7[4] SW = 1, EDMA_TPCC_MPPAN_k. EDMA_TPCC_MPPAN_7[5] SR = 1) with a privilege ID of 0. (EDMA_TPCC_MPPAN_k. EDMA_TPCC_MPPAN_7[10] AID0 = 1).
3. EDMA peripheral modules with a privilege ID of 0 attempts to perform a user-level write of a value of 0xFF00FF00 to shadow region 7's event enable set register EDMA_TPCC_EESR at address offset 0x2E30.

Note

The EDMA_TPCC_EER is a read-only register and the only way that write to it is by writing to the EDMA_TPCC_EESR. There is only one physical register for EDMA_TPCC_EER, EDMA_TPCC_EESR, etc. and that the shadow regions only provide to the same physical set.

4. Since the EDMA_TPCC_MPPAN_k. EDMA_TPCC_MPPAN_7[1] UW = 0, though the privilege ID of the write access is set to 0, the access is not allowed and the EDMA_TPCC_EER is not written too.

Table 11-20. Example Access Denied

Register	Value	Description
EDMA_TPCC_EER (offset 0x1020)	0x0000 0000	Value in EDMA_TPCC_EER to begin with.
EDMA_TPCC_EESR (offset 0x2E30)	0xFF00 FF00 ↓	Value attempted to be written to shadow region 7's EDMA_TPCC_EESR. This is done by an EDMA connected device module with a privilege level of User and Privilege ID of 0.
EDMA_TPCC_MPPAN_k N_k (offset 0x082C)	0x0000 04B0 X	Memory Protection Filter EDMA_TPCC_MPPAN_k[10] AID0 = 1, EDMA_TPCC_MPPAN_k[1] UW = 0, EDMA_TPCC_MPPAN_k[2] UR = 0, EDMA_TPCC_MPPAN_k[4] SW = 1, EDMA_TPCC_MPPAN_k[5] SR = 1. Access Denied
EDMA_TPCC_EER (offset 0x1020)	0x0000 0000	Final value of EDMA_TPCC_EER

Example Access Allowed

Write access to shadow region 7's event enable set register EDMA_TPCC_EESR:

1. The original value of the event enable register EDMA_TPCC_EER at address offset 0x1020 is 0x0.
2. The EDMA_TPCC_MPPAN_k.EDMA_TPCC_MPPAN_7 is set to allow user-level accesses (EDMA_TPCC_MPPAN_k.EDMA_TPCC_MPPAN_7[1] UW = 1, EDMA_TPCC_MPPAN_k. EDMA_TPCC_MPPAN_7[2] UR = 1) and supervisor-level accesses (EDMA_TPCC_MPPAN_k. EDMA_TPCC_MPPAN_7[4] SW = 1, EDMA_TPCC_MPPAN_k. EDMA_TPCC_MPPAN_7[5] SR = 1) with a privilege ID of 0. (EDMA_TPCC_MPPAN_k. EDMA_TPCC_MPPAN_7[10] AID0 = 1).
3. EDMA peripheral modules with a privilege ID of 0, attempts to perform a user-level write of a value of 0xABCD0123 to shadow region 7's event enable set register EDMA_TPCC_EESR at address offset 0x2E30.

Note

The EDMA_TPCC_EER is a read-only register and the only way that write to it is by writing to the EDMA_TPCC_EESR. There is only one physical register for EDMA_TPCC_EER, EDMA_TPCC_EESR, etc. and that the shadow regions only provide to the same physical set.

4. Since the EDMA_TPCC_MPPAN_k. EDMA_TPCC_MPPAN_7[1] UW = 1 and EDMA_TPCC_MPPAN_k. MPPAN_7[10] AID0 = 1, the user-level write access is allowed.
5. The accesses to shadow region registers are masked by their respective EDMA_TPCC_DRAEM_k register. In this example, the EDMA_TPCC_DRAEM_k. EDMA_TPCC_DRAEM_7 is set of 0x9FF00FC2.
6. The value finally written to EDMA_TPCC_EER is 0x8BC00102.

Table 11-21. Example Access Allowed

Register	Value	Description
EDMA_TPCC_EER (offset 0x1020)	0x0000 0000	Value in EER to begin with.
EDMA_TPCC_EESR (offset 0x2E30)	0xFF00 FF00	Value attempted to be written to shadow region 7's EESR. This is done by an EDMA peripheral module with a privilege level of User and Privilege ID of 0.
EDMA_TPCC_MPPAN_k. EDMA_TPCC_MPPAN_7 (offset 0x082C)	0x0000 04B3	Memory Protection Filter EDMA_TPCC_MPPAN_k[10] AID = 1, EDMA_TPCC_MPPAN_k. EDMA_TPCC_MPPAN_7[1] UW = 1, EDMA_TPCC_MPPAN_k. EDMA_TPCC_MPPAN_7[2] UR = 1, EDMA_TPCC_MPPAN_k. EDMA_TPCC_MPPAN_7[4] SW = 1, EDMA_TPCC_MPPAN_k. EDMA_TPCC_MPPAN_7[5] SR = 1.
	√ ↓	Access allowed.
EDMA_TPCC_DRAEM_k. EDMA_TPCC_DRAEM_7 (offset 0x0378)	0x9FF0 0FC2 ↓	DMA Region Access Enable Filter
EDMA_TPCC_EESR (offset 0x2E30)	0x8BC0 0102 ↓	Value written to shadow region 7's EESR. This is done by an EDMA peripheral module with a privilege level of User and a Privilege ID of 0.
EDMA_TPCC_EER (offset 0x1020)	0xBC0 0102	Final value of EER.

11.2.3.10.2 Proxy Memory Protection

Proxy memory protection allows an EDMA transfer programmed by a given peripheral module connected to EDMA, to have its permissions travel with the transfer through the EDMA_TPTC. The permissions travel along with the read transactions to the source and the write transactions to the destination endpoints. The EDMA_TPCC_OPT_n[31] PRIV bit and EDMA_TPCC_OPT_n[27:24] PRIVID bit is set with the peripheral module's PRIV value and PRIVID values, respectively, when any part of the PaRAM set is written.

The EDMA_TPCC_OPT_n[31] PRIV is the privilege level (i.e., user vs. supervisor). The EDMA_TPCC_OPT_n[27:24] PRIVID refers to a privilege ID with a number that is associated with an peripheral module connected to EDMA.

These options are part of the TR that are submitted to the transfer controller. The transfer controller uses the above values on their respective read and write command bus so that the target endpoints can perform memory protection checks based on these values.

Consider a parameter set that is programmed by a CPU in user privilege level for a simple transfer with the source buffer on an L2 page and the destination buffer on an L1D page. The EDMA_TPCC_OPT_n[31] PRIV is 0 for user-level and the CPU has a EDMA_TPCC_OPT_n[27:24] PRIVID to 0.

The PaRAM set is shown in [Figure 11-16](#).

Figure 11-16. PaRAM Set Content for Proxy Memory Protection Example

(a) EDMA Parameters

Parameter Contents		Parameter	
0010 0007h		Channel Options Parameter (OPT)	
009F 0000h		Channel Source Address (SRC)	
0001h	0004h	Count for 2nd Dimension (BCNT)	Count for 1st Dimension (ACNT)
00F0 7800h		Channel Destination Address (DST)	
0001h	0001h	Destination BCNT Index (DBIDX)	Source BCNT Index (SBIDX)
0000h	FFFFh	BCNT Reload (BCNTRLD)	Link Address (LINK)
0001h	1000h	Destination CCNT Index (DCIDX)	Source CCNT Index (SCIDX)
0000h	0001h	Reserved	Count for 3rd Dimension (CCNT)

(b) Channel Options Parameter (OPT_n) Content

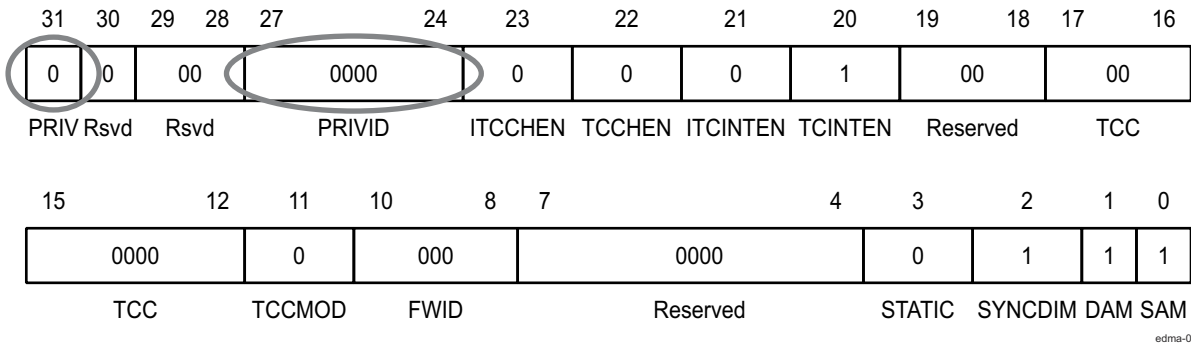

Figure 11-17. Channel Options Parameter (OPT) Example

The EDMA_TPCC_OPT_n[31] PRIV and EDMA_TPCC_OPT_n[27:24] PRIVID information travels along with the read and write requests that are issued to the source and destination memories.

For example, if the access attributes that are associated with the L2 page with the source buffer only allow supervisor read, write accesses EDMA_TPCC_MPPAN_k[4] SW and EDMA_TPCC_MPPAN_k[5] SR, the user-level read request above is refused. Similarly, if the access attributes that are associated with the L1D page with the destination buffer only allow supervisor read and write accesses (EDMA_TPCC_MPPAN_k[4] SW, EDMA_TPCC_MPPAN_k[5] SR), the user-level write request above is refused. For the transfer to succeed, the source and destination pages must have user-read and user-write permissions, respectively, along with allowing accesses from a PRIVID = 0.

Because the privilege level and privilege identification travel with the read and write requests, EDMA acts as a proxy.

Figure 11-18 illustrates the propagation of EDMA_TPCC_OPT_n[31] PRIV and EDMA_TPCC_OPT_n[27:24] PRIVID at the boundaries of all the interacting entities (CPU, EDMA_TPCC, EDMA_TPTCs, and slave memories).

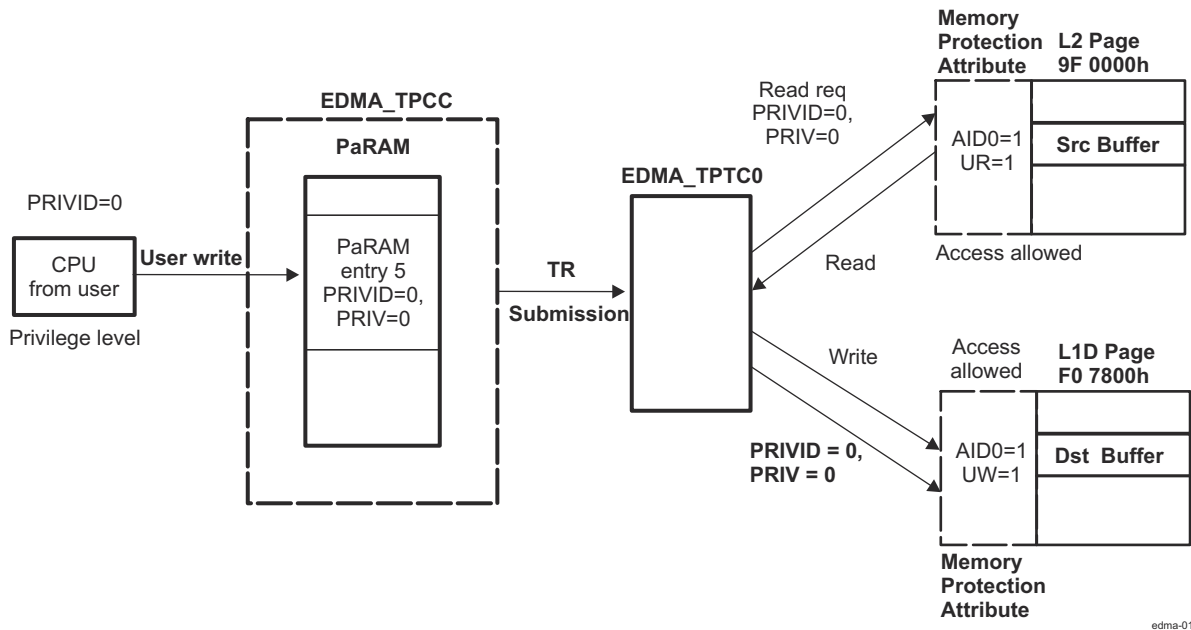

Figure 11-18. Proxy Memory Protection Example

11.2.3.11 Event Queue(s)

Event queues are a part of the EDMA channel controller. Event queues form the interface between the event detection logic in the EDMA_TPCC and the transfer request (TR) submission logic of the EDMA_TPCC. Each queue is 16 entries deep. Each event queue can queue a maximum of 16 events. If there are more than 16 events, then the events that cannot find a place in the event queue remain set in the associated event register and the CPU does not stall.

There are two event queues for the device: Queue0, Queue1. Events in Queue0 result in submission of its associated transfer requests (TRs) to TC0. The transfer requests that are associated with events in Queue1 are submitted to TC1.

An event that wins prioritization against other DMA and/or QDMA pending events is placed at the tail of the appropriate event queue. Each event queue is serviced in FIFO order. Once the event reaches the head of its queue and the corresponding transfer controller is ready to receive another TR, the event is de-queued and the PaRAM set corresponding to the de-queued event is processed and submitted as a transfer request packet (TRP) to the associated EDMA transfer controller.

Queue0 has highest priority and Queue1 has the lowest priority, if Queue0 and Queue1 both have at least one event entry and if both TC0 and TC1 can accept transfer requests, then the event in Queue0 is de-queued first and its associated PaRAM set is processed and submitted as a transfer request (TR) to TC0.

Refer to [Section 11.2.3.11.4](#) for system-level performance considerations. All of the event entries in all of the event queues are software readable (not writeable) by accessing the event entry registers EDMA_TPCC_Q0E_p and EDMA_TPCC_Q1E_p. Each event entry register characterizes the queued event in terms of the type of event (manual, event, chained or auto-triggered) and the event number. Refer to the associated Register Addendum for EDMA_TPCC_Q0E_p / EDMA_TPCC_Q1E_p descriptions of the bit fields.

11.2.3.11.1 DMA/QDMA Channel to Event Queue Mapping

Each of the 64 DMA channels and eight QDMA channels are programmed independently to map to a specific queue, using the DMA queue number register EDMA_TPCC_DMAQNUMN_k and the QDMA queue number register EDMA_TPCC_QDMAQNUM. The mapping of DMA/QDMA channels is critical to achieving the desired performance level for the EDMA and most importantly, in meeting real-time deadlines. Refer to [Section 11.2.3.11.4 System-level Performance Considerations](#).

Note

If an event is ready to be queued and both the event queue and the EDMA transfer controller that is associated to the event queue are empty, then the event bypasses the event queue, and moves the PaRAM processing logic, and eventually to the transfer request submission logic for submission to the EDMA_TPTC. In this case, the event is not logged in the event queue status registers.

11.2.3.11.2 Queue RAM Debug Visibility

There are two event queues and each queue has 16 entries. These 16 entries are managed in a circular FIFO. There is a queue status register EDMA_TPCC_QSTATN_i associated with each queue. These along with all of the 16 entries per queue can be read via registers EDMA_TPCC_QSTATN_i and Q0E_p / Q1E_p, respectively.

These registers provide user visibility.

The event queue entry register (QxEy Q0E_p / Q1E_p) uniquely identifies the specific event type (event-triggered, manually-triggered, chain-triggered, and QDMA events) along with the event number (for all DMA/QDMA event channels) that are in the queue or have been de-queued (passed through the queue).

Each of the 16 entries in the event queue are read using the EDMA_TPCC memory-mapped register. To see the history of the last 16 TRs that have been processed by the EDMA on a given queue, read the event queue registers. This provides user/software visibility and is helpful for debugging real-time issues (typically post-mortem), involving multiple events and event sources.

The queue status register (QSTAT n EDMA_TPCC_QSTATN $_i$) includes fields for the start pointer EDMA_TPCC_QSTATN $_i$ [3:0] STRTPTR which provides the offset to the head entry of an event. It also includes a field called EDMA_TPCC_QSTATN $_i$ [12:8] NUMVAL that provides the total number of valid entries residing in the event queue at a given instance of time. The EDMA_TPCC_QSTATN $_i$ [3:0] STRTPTR is used to index appropriately into the 16 event entries. EDMA_TPCC_QSTATN $_i$ [12:8] NUMVAL number of entries starting from STRTPTR are indicative of events still queued in the respective queue. The remaining entry must be read to determine what's already de-queued and submitted to the associated transfer controller.

11.2.3.11.3 Queue Resource Tracking

The EDMA_TPCC event queue includes watermarking/threshold logic that allows to keep track of maximum usage of all event queues. This is useful for debugging real-time deadline violations that may result from head-of-line blocking on a given EDMA event queue.

The maximum number of events are programmed that the queue up in an event queue by programming the threshold value (between 0 to 15) in the queue watermark threshold A register EDMA_TPCC_QWMTHRA. The maximum queue usage is recorded actively in the watermark EDMA_TPCC_QSTATN $_i$ [20:16] WM field of the queue status register, that keeps getting updated based on a comparison of number of valid entries, which is also visible in the EDMA_TPCC_QSTATN $_i$ [12:8] NUMVAL bit and the maximum number of entries.

If the queue usage is exceeded, this status is visible in the EDMA_TPCC registers: the QTHRXC Dn bits in the channel controller error register EDMA_TPCC_CCERR[7:0] and the EDMA_TPCC_QSTATN $_i$ [24] THRXC D bit, where n stands for the event queue number. Any bits that are set in EDMA_TPCC_CCERR also generate an EDMA_TPCC error interrupt.

11.2.3.11.4 Performance Considerations

The device system bus infrastructure arbitrates bus requests from all of the controllers (TCs, CPU(S), and other bus controllers) to the shared target resources (peripherals and memories).

The priorities of transfer requests (read and write commands) from the EDMA transfer controllers with respect to other controllers within the device IRQ_CROSSBAR are programmed using the Control Module registers. The EDMA_TPCC_QUEPRI register has no affect.

Therefore, the priority of unloading queues has a secondary affect compared to the priority of the transfers as they are executed by the EDMA_TPTC (dictated by the priority set using the Control Module registers, refer to *Control Module Register Manual* in the *Control Module* chapter).

11.2.3.12 EDMA Transfer Controller (EDMA_TPTC)

The EDMA channel controller is the user-interface of the EDMA and the EDMA transfer controller (EDMA_TPTC) is the data movement engine of the EDMA controller. The EDMA_TPCC submits transfer requests (TR) to the EDMA_TPTC and the EDMA_TPTC performs the data transfers dictated by the TR, so the EDMA_TPTC is a slave to the EDMA_TPCC.

11.2.3.12.1 Architecture Details

11.2.3.12.1.1 Command Fragmentation

The TC read and write controllers in conjunction with the source and destination register sets are responsible for issuing optimally-sized reads and writes to the slave endpoints. An optimally-sized command is defined by the transfer controller default burst size (DBS), which is defined in the *TPTC DBS Configuration registers*.

The EDMA_TPTC attempts to issue the largest possible command size as limited by the DBS value or the EDMA_TPCC_ABCNT $_n$ [15:0] ACNT and EDMA_TPCC_ABCNT $_n$ [31:16] BCNT value of the TR. EDMA_TPTC obeys the following rules:

- The read/write controllers always issue commands less than or equal to the DBS value.
- The first command of a 1D transfer command always aligns the address of subsequent commands to the DBS value.

[Table 11-22](#) lists the TR segmentation rules that are followed by the EDMA_TPTC. In summary, if the EDMA_TPCC_ABCNT $_n$ [15:0] ACNT value is larger than the DBS value, then the EDMA_TPTC breaks the

EDMA_TPCC_ABCNT_n[15:0] ACNT array into DBS-sized commands to the source/destination addresses. Each EDMA_TPCC_ABCNT_n[31:16] BCNT number of arrays are then serviced in succession.

For BCNT arrays of ACNT bytes (that is, a 2D transfer), if the EDMA_TPCC_ABCNT_n[15:0] ACNT value is less than or equal to the DBS value, then the TR may be optimized into a 1D-transfer in order to maximize efficiency. The optimization takes place if the EDMA_TPTC recognizes that the 2D-transfer is organized as a single dimension (EDMA_TPCC_ABCNT_n[15:0] ACNT == EDMA_TPCC_BIDX_n) and the ACNT value is a power of 2.

Table 11-22 lists conditions in which the optimizations are performed.

Table 11-22. Read/Write Command Optimization Rules

ACNT ≤ DBS	ACNT is power of 2	BIDX = ACNT	BCNT ≤ 1023	SAM/DAM = Increment	Description
Yes	Yes	Yes	Yes	Yes	Optimized
No	x	x	x	x	Not Optimized
x	No	x	x	x	Not Optimized
x	x	No	x	x	Not Optimized
x	x	x	No	x	Not Optimized
x	x	x	x	No	Not Optimized

11.2.3.12.1.2 TR Pipelining

TR pipelining refers to the ability of the source active set to proceed ahead of the destination active set. Essentially, the reads for a given TR may already be in progress while the writes of a previous TR may not have completed.

The number of outstanding TRs is limited by the number of destination FIFO register entries.

TR pipelining is useful for maintaining throughput on back-to-back small TRs. It minimizes the startup overhead because reads start in the background of a previous TR writes.

Example 11-4. Command Fragmentation (DBS = 64)

The pseudo code:

1. EDMA_TPTCn_PCNT[15:0] ACNT = 8, EDMA_TPTCn_PCNT[31:16] BCNT = 8,
EDMA_TPTCn_PBIDX[15:0] SBIDX = 8, EDMA_TPTCn_PBIDX[31:16] DBIDX = 10,
EDMA_TPTCn_PSRC[31:0] SADDR = 64, EDMA_TPTCn_SADST[31:0] DADDR = 191

Read Controller: This is optimized from a 2D-transfer to a 1D-transfer such that the read side is equivalent to EDMA_TPTCn_PCNT[15:0] ACNT = 64, EDMA_TPTCn_PCNT[31:16] BCNT = 1.

Cmd0 = 64 byte

Write Controller: Because DBIDX != ACNT, it is not optimized.

Cmd0 = 8 byte, Cmd1 = 8 byte, Cmd2 = 8 byte, Cmd3 = 8 byte, Cmd4 = 8 byte, Cmd5 = 8 byte, Cmd6 = 8 byte, Cmd7 = 8 byte.

2. EDMA_TPTCn_PCNT[15:0] ACNT=128, EDMA_TPTCn_PCNT[31:16] BCNT = 1,
EDMA_TPTCn_PSRC[31:0] SADDR = 63, EDMA_TPTCn_SADST[31:0] DADDR = 513

Read Controller: Read address is not aligned.

Cmd0 = 1 byte, (now the SADDR is aligned to 64 for the next command)

Cmd1 = 64 bytes

Cmd2 = 63 bytes

Write Controller: The write address is also not aligned.

Cmd0 = 63 bytes, (now the DADDR is aligned to 64 for the next command)

Cmd1 = 64 bytes

Cmd2 = 1 byte

11.2.3.12.1.3 Performance Tuning

By default, reads are as issued as fast as possible. In some cases, the reads issued by the EDMA_TPTC could fill the available command buffering for a target, delaying other (potentially higher priority) controllers from successfully submitting commands to that target. The rate at which read commands are issued by the EDMA_TPTC is controlled by the EDMA_TPTCn_RDRATE register. The EDMA_TPTCn_RDRATE register defines the number of cycles that the EDMA_TPTC read controller waits before issuing subsequent commands for a given TR, thus minimizing the chance of the EDMA_TPTC consuming all available target resources. The EDMA_TPTCn_RDRATE[2:0] RDRATE value must be set to a relatively small value if the transfer controller is targeted for high priority transfers and to a higher value if the transfer controller is targeted for low priority transfers.

In contrast, the Write Interface does not have any performance turning knobs because writes always have an interval between commands as write commands are submitted along with the associated write data.

11.2.3.12.2 Memory Protection

The transfer controller plays an important role in handling proxy memory protection. There are two access properties associated with a transfer: for instance, the privilege id (system-wide identification assigned to a controller) of the controller initiating the transfer, and the privilege level (user versus supervisor) used to program the transfer. This information is maintained in the PaPARAM set when it is programmed in the channel controller. When a TR is submitted to the transfer controller, this information is made available to the EDMA_TPTC and used by the EDMA_TPTC while issuing read and write commands. The read or write commands have the same privilege identification, and privilege level as that programmed in the EDMA transfer in the channel controller.

11.2.3.12.3 Error Generation

Errors are generated if enabled under three conditions:

- EDMA_TPTC detection of an error signaled by the source or destination address.
- Attempt to read or write to an invalid address in the configuration memory map.
- Detection of a constant addressing mode TR violating the constant addressing mode transfer rules (the source/destination addresses and source/destination indexes must be aligned to 32 bytes).

Either or all error types may be disabled. If an error bit is set and enabled, the error interrupt for the concerned transfer controller is generated.

11.2.3.12.4 Debug Features

The DMA program register set, DMA source active register set, and the destination FIFO register set are used to derive a brief history of TRs serviced through the transfer controller.

Additionally, the EDMA_TPTC status register EDMA_TPTCn_TCSTAT has dedicated bit fields to indicate the ongoing activity within different parts of the transfer controller:

- The EDMA_TPTCn_TCSTAT[1] SRCACTV bit indicates whether the source active set is active.
- The EDMA_TPTCn_TCSTAT[6:4] DSTACTV bit indicates the number of TRs resident in the destination register active set at a given instance.
- The EDMA_TPTCn_TCSTAT[0] PROGBUSY bit indicates whether a valid TR is present in the DMA program set.

Note

If the TRs are in progression, it must realize that there is a chance that the values read from the EDMA_TPTC status registers will be inconsistent since the EDMA_TPTC changes the values of these registers due to ongoing activities.

It is recommended that to ensure no additional submission of TRs to the EDMA_TPTC in order to facilitate ease of debug.

11.2.3.12.4.1 Destination FIFO Register Pointer

The destination FIFO register pointer is implemented as a circular buffer with the start pointer being EDMA_TPTCn_TCSTAT[12:11] DFSTRTPTR and a buffer depth of usually 2 or 4. The EDMA_TPTC maintains two important status details in EDMA_TPTCn_TCSTAT that are used during advanced debugging, if necessary. The EDMA_TPTCn_TCSTAT[12:11] DFSTRTPTR is a start pointer, the index to the head of the destination FIFO register. The EDMA_TPTCn_TCSTAT[6:4] DSTACTV is a counter for the number of valid (occupied) entries. These registers are used to get a brief history of transfers.

Examples of some register field values and their interpretation:

- EDMA_TPTCn_TCSTAT[12:11] DFSTRTPTR = 0x0 and EDMA_TPTCn_TCSTAT[6:4] DSTACTV = 0x0 implies that no TRs are stored in the destination FIFO register.
- EDMA_TPTCn_TCSTAT[12:11] DFSTRTPTR = 0x1 and EDMA_TPTCn_TCSTAT[6:4] DSTACTV = 0x2 implies that two TRs are present. The first pending TR is read from the destination FIFO register entry 1 and the second pending TR is read from the destination FIFO register entry 2.
- EDMA_TPTCn_TCSTAT[12:11] DFSTRTPTR = 0x3 and EDMA_TPTCn_TCSTAT[6:4] DSTACTV = 0x2 implies that two TRs are present. The first pending TR is read from the destination FIFO register entry 3 and the second pending TR is read from the destination FIFO register entry 0.

11.2.3.13 Event Dataflow

This section summarizes the data flow of a single event, from the time the event is latched to the channel controller to the time the transfer completion code is returned. The following steps list the sequence of EDMA_TPCC activity:

1. Event is asserted from an external source (peripheral or external interrupt). This also is similar for a manually-triggered, chained-triggered, or QDMA-triggered event. The event is latched into the EDMA_TPCC_ER[31:0]En / EDMA_TPCC_ERH[31:0] En (or EDMA_TPCC_CER[31:0] En / EDMA_TPCC_CERH[31:0] En, EDMA_TPCC_ESR[31:0] En / EDMA_TPCC_ESRH[31:0] En, EDMA_TPCC_QER[7:0] En) bit.

2. Once an event is prioritized and queued into the appropriate event queue, the EDMA_TPCC_SER[31:0] *En* \ EDMA_TPCC_SERH[31:0] *En* (or EDMA_TPCC_QSER[7:0] *En*) bit is set to inform the event prioritization / processing logic to disregard this event since it is already in the queue. Alternatively, if the transfer controller and the event queue are empty, then the event bypasses the queue.
3. The EDMA_TPCC processing and the submission logic evaluates the appropriate PaRAM set and determines whether it is a non-null and non-dummy transfer request (TR).
4. The EDMA_TPCC clears the EDMA_TPCC_ER[31:0] *En*/ EDMA_TPCC_ERH[31:0] *En* (or EDMA_TPCC_CER[31:0] *En* / EDMA_TPCC_CERH[31:0] *En*, EDMA_TPCC_ESR[31:0] *En* / EDMA_TPCC_ESRH[31:0] *En*, EDMA_TPCC_QER[31:0] *En*) bit and the EDMA_TPCC_SER[31:0] *En*/ EDMA_TPCC_SERH[31:0] *En* bit as soon as it determines the TR is non-null. In the case of a null set, the EDMA_TPCC_SER[31:0] *En*/ EDMA_TPCC_SERH[31:0] *En* bit remains set. It submits the non-null/non-dummy TR to the associated transfer controller. If the TR was programmed for early completion, the EDMA_TPCC immediately sets the interrupt pending register (EDMA_TPCC_IPR[31:0] I[TCC] / EDMA_TPCC_IPRH[31:0] I[TCC] - 32).
5. If the TR was programmed for normal completion, the EDMA_TPCC sets the interrupt pending register (EDMA_TPCC_IPR[31:0] I[TCC] / EDMA_TPCC_IPRH[31:0] I[TCC]) when the EDMA_TPTC informs the EDMA_TPCC about completion of the transfer (returns transfer completion codes).
6. The EDMA_TPCC programs the associated EDMA_TPTC's Program Register Set with the TR.
7. The TR is then passed to the Source Active set and the DST FIFO Register Set, if both the register sets are available.
8. The Read Controller processes the TR by issuing read commands to the source slave endpoint. The Read Data lands in the Data FIFO of the EDMA_TPTC_n.
9. As soon as sufficient data is available, the Write Controller begins processing the TR by issuing write commands to the destination slave endpoint.
10. This continues until the TR completes and the EDMA_TPTC_n then signals completion status to the EDMA_TPCC.

11.2.3.14 EDMA Controller Prioritization

The EDMA controller has many implementation rules to deal with concurrent events/channels, transfers, etc. The following subsections detail various arbitration details whenever there might be occurrence of concurrent activity. [Figure 11-19](#) shows the different places EDMA priorities come into play.

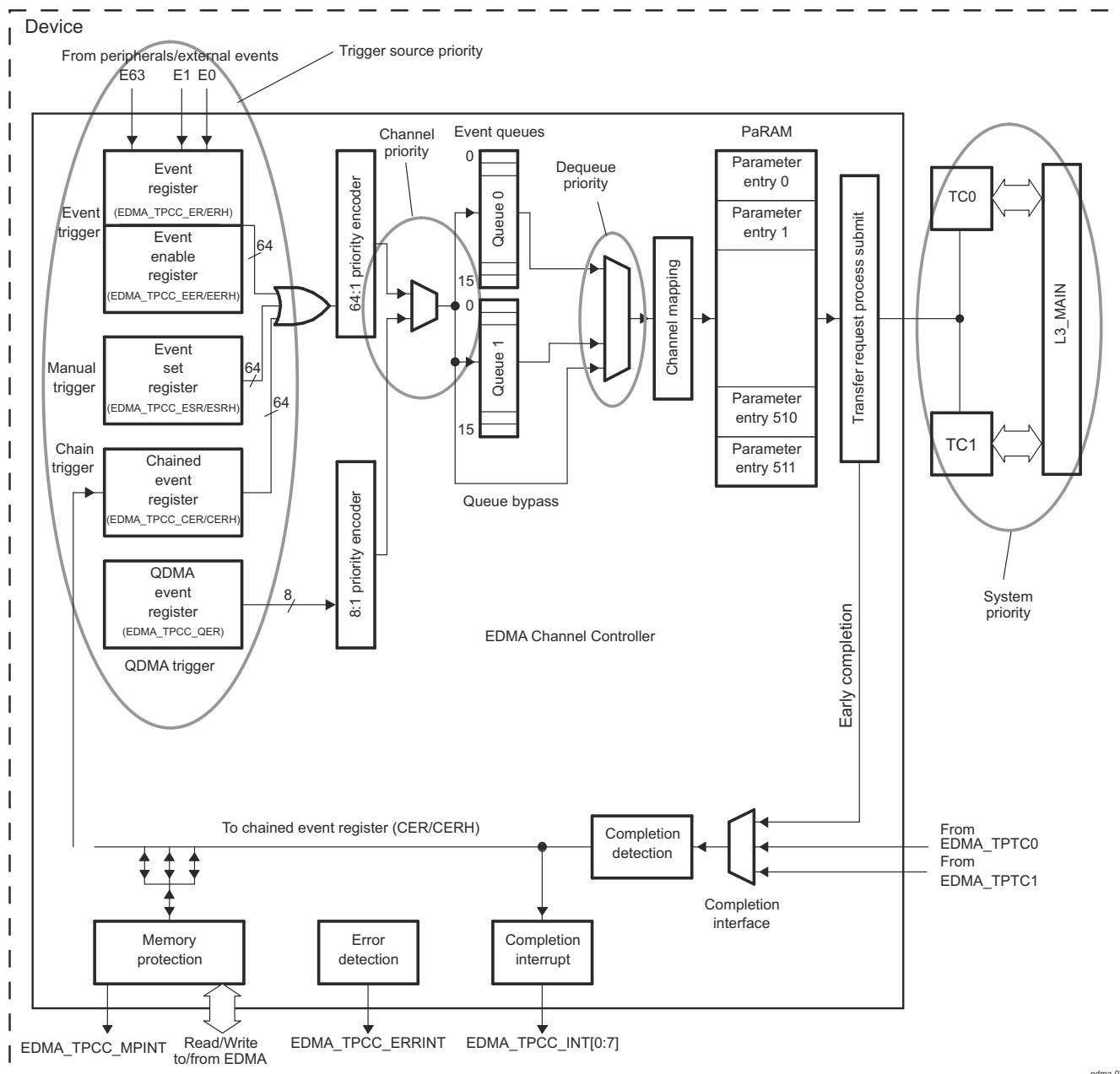

Figure 11-19. EDMA Prioritization

11.2.3.14.1 Channel Priority

The EDMA event registers EDMA_TPCC_ER and EDMA_TPCC_ERH capture up to 64 events, the QDMA event register EDMA_TPCC_QER captures QDMA events for all QDMA channels therefore, it is possible for events to occur simultaneously on the DMA/QDMA event inputs. For events arriving simultaneously, the event associated with the lowest channel number is prioritized for submission to the event queues (for DMA events, channel 0 has the highest priority and channel 63 has the lowest priority, for QDMA events, channel 0 has the highest priority and channel 7 has the lowest priority). This mechanism only sorts simultaneous events for submission to the event queues.

If a DMA and QDMA event occurs simultaneously, the DMA event always has prioritization against the QDMA event for submission to the event queues.

11.2.3.14.2 Trigger Source Priority

If a EDMA channel is associated with more than one trigger source (event trigger, manual trigger, and chain trigger), and if multiple events are set simultaneously for the same channel (EDMA_TPCC_ER[31:0] $E_n = 1$, EDMA_TPCC_ESR[31:0] $E_n = 1$, EDMA_TPCC_CER[31:0] $E_n = 1$), then the EDMA_TPCC always services these events in the following priority order: event trigger (via EDMA_TPCC_ER) is higher priority than chain trigger (via EDMA_TPCC_CER) and chain trigger is higher priority than manual trigger (via EDMA_TPCC_ESR).

This implies that if for channel 0, both EDMA_TPCC_ER[0] $E_0 = 1$ and EDMA_TPCC_CER[0] $E_0 = 1$ at the same time, then the EDMA_TPCC_ER[0] E_0 event is always queued before the EDMA_TPCC_CER[0] E_0 event.

11.2.3.14.3 Dequeue Priority

The priority of the associated transfer request (TR) is further mitigated by which event queue is being used for event submission (dictated by EDMA_TPCC_DMAQNUMN_k and EDMA_TPCC_QDMAQNUM). For submission of a TR to the transfer request, events need to be de-queued from the event queues. Queue 0 has the highest dequeue priority and queue 1 the lowest.

11.2.3.15 Emulation Considerations

During debug when using the emulator, the CPU(s) may be halted on an execute packet boundary for single-stepping, benchmarking, profiling, or other debug purposes. During an emulation halt, the EDMA channel controller and transfer controller operations continue. Events continue to be latched and processed and transfer requests continue to be submitted and serviced.

Since EDMA is involved in servicing multiple controller and target peripherals, it is not feasible to have an independent behavior of the EDMA for emulation halts. EDMA functionality would be coupled with the peripherals it is servicing, which might have different behavior during emulation halts.

11.2.4 EDMA Transfer Examples

The EDMA channel controller performs a variety of transfers depending on the parameter configuration. The following sections provide a description and PaRAM configuration for some typical use case scenarios.

11.2.4.1 Block Move Example

The most basic transfer performed by the EDMA is a block move. During device operation it is often necessary to transfer a block of data from one location to another, usually between on-chip and off-chip memory.

In this example, a section of data is to be copied from external memory to internal L2 SRAM as shown in [Figure 11-20](#).

The source address for the transfer is set to the start of the data block in external memory, and the destination address is set to the start of the data block in L2. If the data block is less than 64K bytes, the PaRAM configuration shown in [Figure 11-21](#) holds true with the synchronization type set to A-synchronized and indexes cleared to 0. If the amount of data is greater than 64K bytes, EDMA_TPCC_ABCNT_n[31:16] BCNT and the B-indexes need to be set appropriately with the synchronization type set to AB-synchronized. The EDMA_TPCC_OPT_n[3] STATIC bit is set to prevent linking.

This transfer example may also be set up using QDMA. For successive transfer submissions, of a similar nature, the number of cycles used to submit the transfer are fewer depending on the number of changing transfer parameters. The QDMA trigger word must be programmed to be the highest numbered offset in the PaRAM set that undergoes change.

[Figure 11-21](#) shows the parameters Block Move transfer.

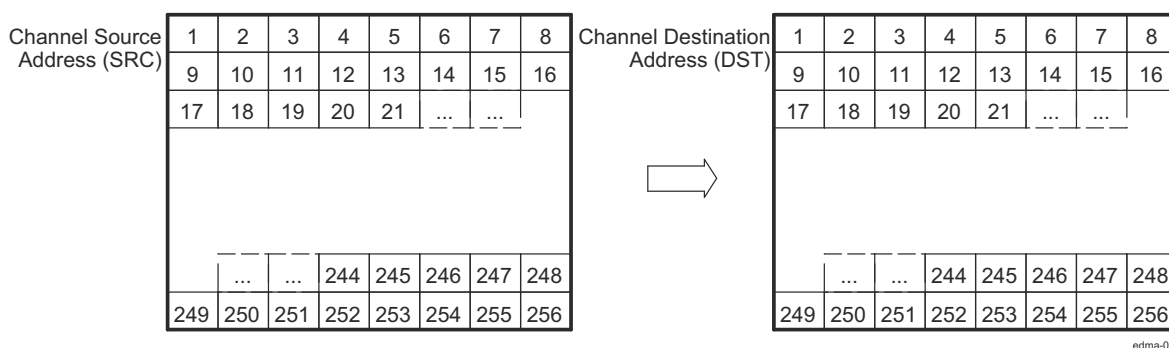

edma-021

Figure 11-20. Block Move Example

Figure 11-21. Block Move Example PaRAM Configuration

(a) EDMA Parameters

Parameter Contents		Parameter	
0010 0008h		Channel Options Parameter (OPT)	
Channel Source Address (SRC)		Channel Source Address (SRC)	
0001h	0100h	Count for 2nd Dimension (BCNT)	Count for 1st Dimension (ACNT)
Channel Destination Address (DST)		Channel Destination Address (DST)	
0000h	0000h	Destination BCNT Index (DBIDX)	Source BCNT Index (SBIDX)
0000h	FFFFh	BCNT Reload (BCNTRLD)	Link Address (LINK)
0000h	0000h	Destination CCNT Index (DCIDX)	Source CCNT Index (SCIDX)
0000h	0001h	Reserved	Count for 3rd Dimension (CCNT)

(b) Channel Options Parameter (OPT) Content

- EDMA_TPCC_OPT_n[3] STATIC = 0x1
- EDMA_TPCC_OPT_n[20] TCINTEN = 0x1

11.2.4.2 Subframe Extraction Example

The EDMA can efficiently extract a small frame of data from a larger frame of data. By performing a 2D-to-1D transfer, the EDMA retrieves a portion of data for the CPU to process. In this example, a 640 × 480-pixel frame of video data is stored in external memory. Each pixel is represented by a 16-bit halfword. The CPU extracts a 16 × 12-pixel subframe of the image for processing. To facilitate more efficient processing time by the CPU, the EDMA places the subframe in internal L2 SRAM. Figure 11-22 shows the transfer of a subframe from external memory to L2.

The same PaRAM entry options are used for QDMA channels, as well as DMA channels. The EDMA_TPCC_OPT_n[3] STATIC bit is set to prevent linking. For successive transfers, only changed parameters need to be programmed before triggering the channel.

Figure 11-23 shows the parameters for Subframe Extraction transfer.

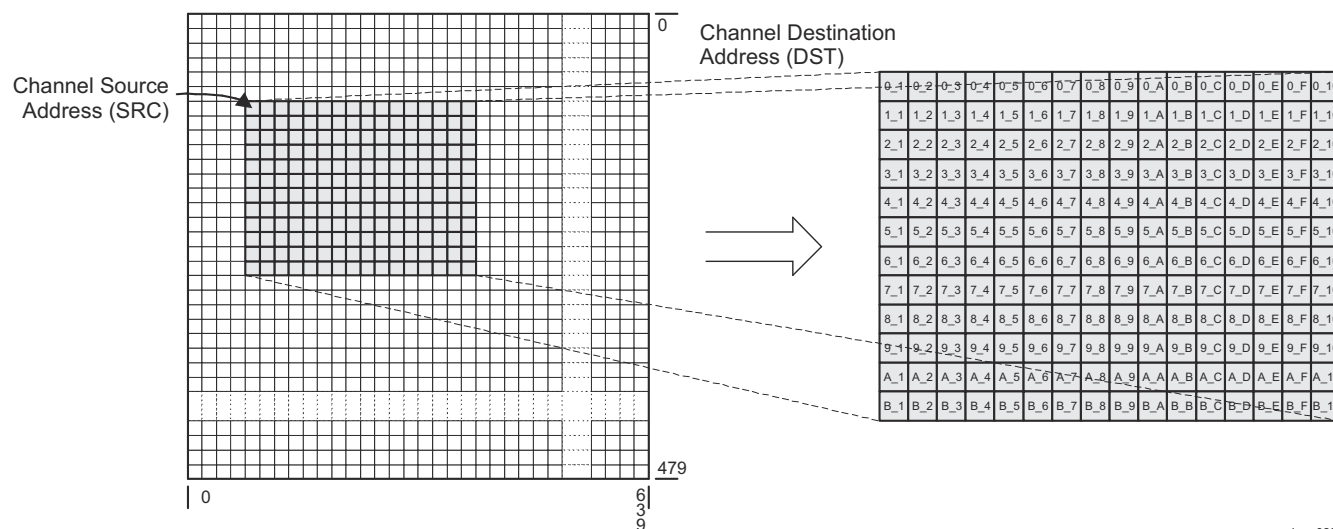

Figure 11-22. Subframe Extraction Transfer

Figure 11-23. Subframe Extraction Example PaRAM Configuration

(a) EDMA Parameters

Parameter Contents		Parameter	
0010 000Ch		Channel Options Parameter (OPT)	
Channel Source Address (SRC)		Channel Source Address (SRC)	
000Ch	0020h	Count for 2nd Dimension (BCNT)	Count for 1st Dimension (ACNT)
Channel Destination Address (DST)		Channel Destination Address (DST)	
0020h	0500h	Destination BCNT Index (DBIDX)	Source BCNT Index (SBIDX)
0000h	FFFFh	BCNT Reload (BCNTRLD)	Link Address (LINK)
0000h	0000h	Destination CCNT Index (DCIDX)	Source CCNT Index (SCIDX)
0000h	0001h	Reserved	Count for 3rd Dimension (CCNT)

(b) Channel Options Parameter (OPT) Content

- EDMA_TPCC_OPT_n[2] SYNCDIM = 0x1
- EDMA_TPCC_OPT_n[3] STATIC = 0x1
- EDMA_TPCC_OPT_n[20] TCINTEN = 0x1

11.2.4.3 Data Sorting Example

Many applications require the use of multiple data arrays, it is often desirable to have the arrays arranged such that the first elements of each array are adjacent, the second elements are adjacent, and so on. Often this is not how the data is presented to the device. Either data is transferred via a peripheral with the data arrays arriving one after the other or the arrays are located in memory with each array occupying a portion of contiguous memory spaces. For these instances, the EDMA can reorganize the data into the desired format.

To determine the parameter set values, the following need to be considered:

- ACNT - Program this to be the size in bytes of an element.
- BCNT - Program this to be the number of elements in a frame.
- CCNT - Program this to be the number of frames.
- SBIDX - Program this to be the size of the element or ACNT.
- DBIDX - CCNT × ACNT
- SCIDX - ACNT × BCNT
- DCIDX - ACNT

The synchronization type needs to be AB-synchronized and the EDMA_TPCC_OPT_n[3] STATIC bit is 0 to allow updates to the parameter set. It is advised to use normal EDMA channels for sorting.

It is not possible to sort this with a single trigger event. Instead, the channel can be programmed to be chained to itself. After BCNT elements get sorted, intermediate chaining could be used to trigger the channel again causing the transfer of the next BCNT elements and so on. Figure 11-25 shows the parameter set programming for this transfer, assuming channel 0 and an element size of 4 bytes.

Figure 11-24 shows the Data Sorting transfer

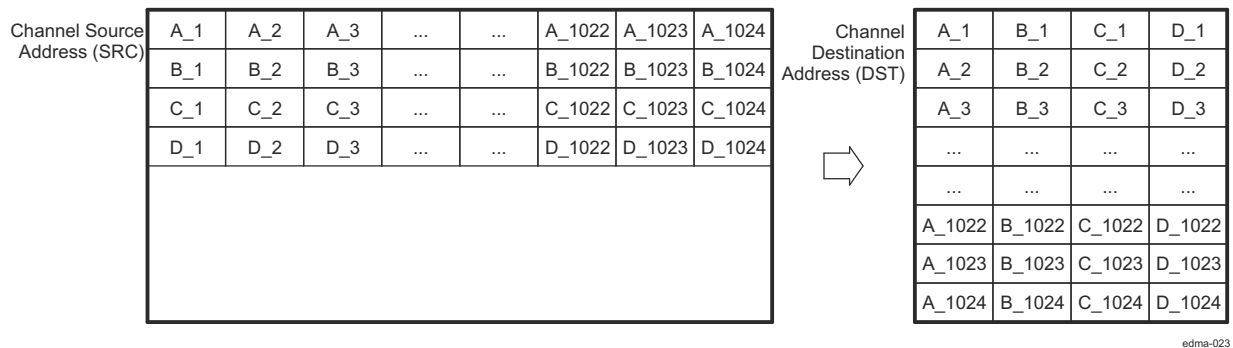

Figure 11-24. Data Sorting Example

Figure 11-25. Data Sorting Example PaRAM Configuration

(a) EDMA Parameters

Parameter Contents		Parameter	
0090 0004h		Channel Options Parameter (OPT)	
Channel Source Address (SRC)		Channel Source Address (SRC)	
0400h	0004h	Count for 2nd Dimension (BCNT)	Count for 1st Dimension (ACNT)
Channel Destination Address (DST)		Channel Destination Address (DST)	
0010h	0001h	Destination BCNT Index (DSTBIDX)	Source BCNT Index (SRCBIDX)
0000h	FFFFh	BCNT Reload (BCNTRLD)	Link Address (LINK)
0001h	1000h	Destination CCNT Index (DSTCIDX)	Source CCNT Index (SRCCIDX)
0000h	0004h	Reserved	Count for 3rd Dimension (CCNT)

(b) Channel Options Parameter (OPT) Content

- EDMA_TPCC_OPT_n[2] SYNCDIM = 0x1
- EDMA_TPCC_OPT_n[20] TCINTEN = 0x1
- EDMA_TPCC_OPT_n[23] ITCCHEN = 0x1

11.2.4.4 Setting Up an EDMA Transfer

The following list provides a quick guide for the typical steps involved in setting up a transfer.

1. Initiating a DMA/QDMA channel
 - a. Determine the type of channel (QDMA or DMA) to be used.
 - b. Channel mapping
 - i. If using a QDMA channel, program the EDMA_TPCC_QCHMAPN_j with the parameter set number to which the channel maps and the trigger word.
 - ii. If using a DMA channel, program the EDMA_TPCC_DCHMAPN_m with the parameter set number to which the channel maps.
 - c. If the channel is being used in the context of a shadow region, ensure the EDMA_TPCC_DRAEM_k / EDMA_TPCC_DRAEHM_k for the region is properly set up to allow read write accesses to bits in the event registers and interrupt registers in the Shadow region memory map. The subsequent steps in this process should be done using the respective shadow region registers. (Shadow region descriptions and usage are provided in [Section 11.2.3.7.1.](#))
 - d. Determine the type of triggering used.
 - i. If external events are used for triggering (DMA channels), enable the respective event in EDMA_TPCC_EER / EDMA_TPCC_EERH by writing into EDMA_TPCC_EESR / EDMA_TPCC_EESRH.
 - ii. If QDMA Channel is used, enable the channel in EDMA_TPCC_QEER by writing into EDMA_TPCC_QEESR.
 - e. Queue setup
 - i. If a QDMA channel is used, set up the EDMA_TPCC_QDMAQNUM to map the channel to the respective event queue.
 - ii. If a DMA channel is used, set up the EDMA_TPCC_DMAQNUMN_k to map the event to the respective event queue.
2. Parameter set setup
 - a. Program the PaRAM set number associated with the channel. Note that

Note

If it is a QDMA channel, the PaPARAM entry that is configured as trigger word is written to last. Alternatively, enable the QDMA channel (step 1-b-ii above) just before the write to the trigger word.

3. Interrupt setup
 - a. Enable the interrupt in the EDMA_TPCC_IER / EDMA_TPCC_IERH by writing into EDMA_TPCC_IESR / EDMA_TPCC_IESRH.
 - b. Ensure the EDMA_TPCC completion interrupt (this refers to either the Global interrupt or the shadow region interrupt) is enabled properly in the Device Interrupt controller.
 - c. Set up the interrupt controller properly to receive the expected EDMA interrupt.
4. Initiate transfer
 - a. This step is highly dependent on the event trigger source:
 - i. If the source is an external event coming from a peripheral, the peripheral will be enabled to start generating relevant EDMA events that can be latched to the EDMA_TPCC_ER transfer.
 - ii. For QDMA events, writes to the trigger word (step 2-a above) will initiate the transfer.
 - iii. Manually triggered transfers will be initiated by writes to the Event Set Registers EDMA_TPCC_ESR / EDMA_TPCC_ESRH.
 - iv. Chained-trigger events initiate when a previous transfer returns a transfer completion code equal to the chained channel number.
5. Wait for completion
 - a. If the interrupts are enabled as mentioned in step 3 above, then the EDMA_TPCC will generate a completion interrupt to the CPU whenever transfer completion results in setting the corresponding bits in the interrupt pending register EDMA_TPCC_IPR / EDMA_TPCC_IPRH. The set bits must be cleared

- in the EDMA_TPCC_IPR / EDMA_TPCC_IPRH by writing to corresponding bit in EDMA_TPCC_ICR / EDMA_TPCC_ICRH.
- b. If polling for completion (interrupts not enabled in the device controller), then the application code can wait on the expected bits to be set in the EDMA_TPCC_IPR / EDMA_TPCC_IPRH. Again, the set bits in the EDMA_TPCC_IPR / EDMA_TPCC_IPRH must be manually cleared via EDMA_TPCC_ICR / EDMA_TPCC_ICRH before the next set of transfers is performed for the same transfer completion code values.

11.2.5 EDMA Debug Checklist and Programming Tips

This section lists some tips to keep in mind while debugging applications using the EDMA controller.

11.2.5.1 EDMA Debug Checklist

Table 11-23 provides some common issues and their probable causes and resolutions.

Table 11-23. Debug Checklist

Issue	Description/Solution
<p>The transfer associated with the channel does not happen. The channel does not get serviced.</p>	<p>The EDMA_TPCC may not service a transfer request, even though the associated PaRAM set is programmed appropriately. Check for the following:</p> <ol style="list-style-type: none"> 1) Verify that events are enabled, i.e., if an external/peripheral event is latched in Event Registers EDMA_TPCC_ER / EDMA_TPCC_ERH, check that the event is enabled in the Event Enable Registers EDMA_TPCC_EER / EDMA_TPCC_EERH. Similarly, for QDMA channels, check that QDMA events are appropriately enabled in the QDMA Event Enable Register EDMA_TPCC_QEER. 2) Verify that the DMA or QDMA Secondary Event Register EDMA_TPCC_SER / EDMA_TPCC_SERH / EDMA_TPCC_QSER bits corresponding to the particular event or channel are not set.
<p>The Secondary Event Registers bits are set, not allowing additional transfers to occur on a channel.</p>	<p>It is possible that a trigger event was received when the parameter set associated with the channel/event was a NULL set for a previous transfer on the channel. This is typical in two cases:</p> <ol style="list-style-type: none"> 1) QDMA channels: Typically if the parameter set is non-static and expected to be terminated by a NULL set (i.e., EDMA_TPCC_OPT_n[3] STATIC = 0x0, EDMA_TPCC_LNK_n[15:0] LINK = 0xFFFF), the parameter set is updated with a NULL set after submission of the last TR. Because QDMA channels are auto-triggered, this update caused the generation of an event. An event generated for a NULL set causes an error condition and results in setting the bits corresponding to the QDMA channel in the EDMA_TPCC_QEMR and EDMA_TPCC_QSER. This will disable further prioritization of the channel. 2) DMA channels used in a continuous mode: The peripheral may be set up to continuously generate infinite events (for instance, in case of McASP, every time the data shifts out from the DXR register, it generates an XEVT). The parameter set may be programmed to expect only a finite number of events and to be terminated by a NULL link. After the expected number of events, the parameter set is reloaded with a NULL parameter set. Because the peripheral will generate additional events, an error condition is set in the EDMA_TPCC_SER[31:0] En and EDMA_TPCC_EMR[31:0] En set, preventing further event prioritization. <p>Check the number of events received is limited to the expected number of events for which the parameter set is programmed, or check the bits corresponding to particular channel or event are not set in the Secondary event registers (EDMA_TPCC_SER / EDMA_TPCC_SERH / EDMA_TPCC_QSER) and Event Missed Registers (EDMA_TPCC_EMR / EDMA_TPCC_EMRH / EDMA_TPCC_QEMR) before trying to perform subsequent transfers for the event/channel.</p>

Table 11-23. Debug Checklist (continued)

Issue	Description/Solution
Completion interrupts are not asserted, or no further interrupts are received after the first completion interrupt.	Check the following: <ol style="list-style-type: none"> 1) The interrupt generation is enabled in the EDMA_TPCC_OPT_n of the associated PaRAM set (EDMA_TPCC_OPT_n[20] TCINTEN = 0x1 and/or EDMA_TPCC_OPT_n[20] ITCINTEN = 0x1). 2) The interrupts are enabled in the EDMA Channel Controller, via the Interrupt Enable Registers (EDMA_TPCC_IER / EDMA_TPCC_IERH). 3) The corresponding interrupts are enabled in the device interrupt controller. 4) The set interrupts are cleared in the interrupt pending registers (EDMA_TPCC_IPR / EDMA_TPCC_IPRH) before exiting the transfer completion interrupt service routine (ISR). See Section 11.2.3.9.1.2 Clearing Transfer Completion Interrupts for details on writing EDMA ISRs. 5) If working with shadow region interrupts, make sure that the DMA Region Access registers (EDMA_TPCC_DRAEM_k / EDMA_TPCC_DRAEHM_k) are set up properly, because the EDMA_TPCC_DRAEM_k / EDMA_TPCC_DRAEHM_k registers act as secondary enables for shadow region completion interrupts, along with the EDMA_TPCC_IER / EDMA_TPCC_IERH registers. If working with shadow region interrupts, make sure that the bits corresponding to the transfer completion code EDMA_TPCC_OPT_n[17:12] TCC value are also enabled in the EDMA_TPCC_DRAEM_k / EDMA_TPCC_DRAEHM_k registers. For instance, if the PaRAM set associated with Channel 0 returns a completion code of 63 EDMA_TPCC_OPT_n[17:12] TCC = 63, ensure that EDMA_TPCC_DRAEHM_k[31] E63 is also set for a shadow region completion interrupt because the interrupt pending register bit set will be EDMA_TPCC_IPRH[31] I63 (not EDMA_TPCC_IPR[0] I0).

11.2.5.2 EDMA Programming Tips

1. For several registers, the setting and clearing of bits needs to be done via separate dedicated registers. For example, the Event Register (EDMA_TPCC_ER / EDMA_TPCC_ERH) can only be cleared by writing a 1 to the corresponding bits in the Event Clear Registers (EDMA_TPCC_ECR / EDMA_TPCC_ECRH). Similarly, the Event Enable Register (EDMA_TPCC_EER / EDMA_TPCC_EERH) bits can only be set with writing of 0x1 to the Event Enable Set Registers (EDMA_TPCC_EESR / EDMA_TPCC_EESRH) and cleared with writing of 0x1 to the corresponding bits in the Event Enable Clear Register (EDMA_TPCC_EECR / EDMA_TPCC_EECRH).
2. Writes to the shadow region memory maps are governed by region access registers (EDMA_TPCC_DRAE / EDMA_TPCC_DRAEHM_k / EDMA_TPCC_QRAEN_k). If the appropriate channels are not enabled in these registers, read/write access to the shadow region memory map is not enabled.
3. When working with shadow region completion interrupts, ensure that the DMA Region Access Registers (EDMA_TPCC_DRAEM_k / EDMA_TPCC_DRAEHM_k) for every region are set in a mutually exclusive way (unless it is a requirement for an application). If there is an overlap in the allocated channels and transfer completion codes (setting of Interrupt Pending Register bits) in the region resource allocation, it results in multiple shadow region completion interrupts.
For example, if EDMA_TPCC_DRAEM_k.DRAEM_0[0] E0 and EDMA_TPCC_DRAEM_k.DRAEM_1[0] E0 are both set, then on completion of a transfer that returns a TCC = 0x0, they will generate both shadow region 0 and 1 completion interrupts.
4. While programming a non-dummy parameter set, ensure the EDMA_TPCC_CCNT_n[15:0] CCNT is not left to zero.
5. Enable the EDMA_TPCC error interrupt in the device controller and attach an interrupt service routine (ISR) to ensure that error conditions are not missed in an application and are appropriately addressed with the ISR.
6. Depending on the application, it can want to break large transfers into smaller transfers and use self-chaining to prevent starvation of other events in an event queue.
7. In applications where a large transfer is broken into sets of small transfers using chaining or other methods, it chooses to use the early chaining option to reduce the time between the sets of transfers and increase the throughput.
However, keep in mind that with early completion, all data might have not been received at the end point when completion is reported because the EDMA_TPCC internally signals completion when the TR is submitted to the EDMA_TPTC, potentially before any data has been transferred.
8. The event queue entries can be observed to determine the last few events if there is a system failure (provided the entries were not bypassed).

11.2.6 EDMA Event Map

This content is under-construction. Note is included as a placeholder for future developments.

This page intentionally left blank.



This chapter describes the time sync modules in the device.

12.1 Time Sync Architecture	870
12.2 Time Sync Routers	872
12.3 Time Sync and Compare Events	878

12.1 Time Sync Architecture

This section provides a high-level overview of the SoC time synchronization architecture.

12.1.1 Time Sync Architecture Overview

[Table 12-1](#) shows the time synchronization functions supported by the device.

Table 12-1. Time Synchronization Functions in the SOC

Interface	Time Sync Functions	Supported by
PRU-ICSS	IEEE 1588-2008 (1/2-step), 802.1AS, TSN	PRU-ICSS firmware
CPSW0	IEEE 1588-2008 (2-step), 802.1AS	CPTS in CPSW0
EPWMx.SYNCOUT	PWM SYNCOUT	EPWMx.SYNCOUT

Note

These time sync functions are described in detail in their respective chapters.

Any of these functions can be a time sync master in the system. Sync routers (SOC_TIMESYNC_XBAR0, SOC_TIMESYNC_XBAR1) provide flexibility for each time domain to choose its synch master independently. In addition these routers also provide selection of sync and compare events for routing as CPU or DMA events.

[Figure 12-1](#) shows a high-level overview of the SoC time sync architecture.

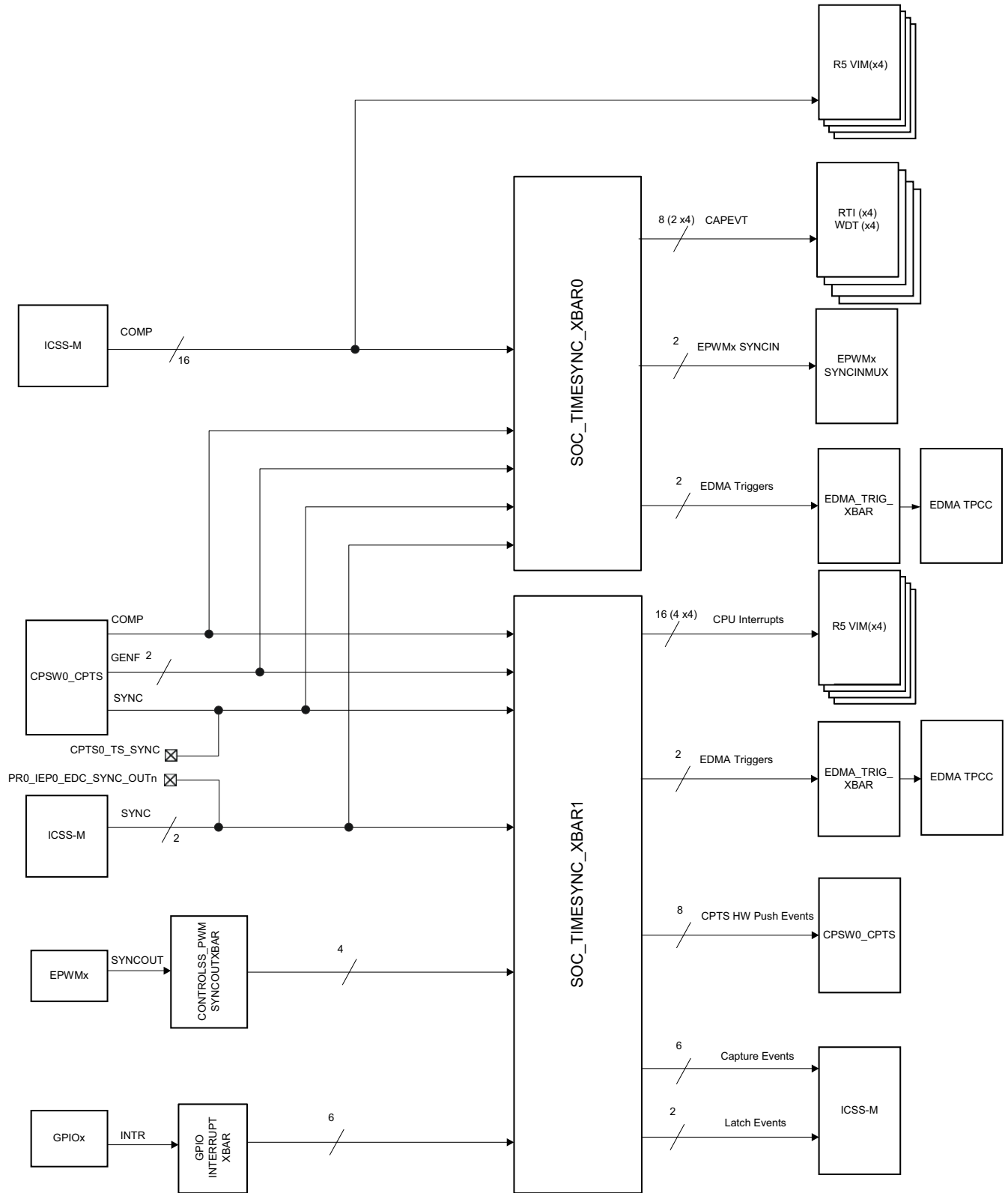

ADVANCE INFORMATION

Figure 12-1. SoC Time Sync Architecture

12.2 Time Sync Routers

12.2.1 Time Sync Routers Overview

12.2.1.1 SOC_TIMESYNC_XBAR0 Overview

The Time Sync Event Router0 (**SOC_TIMESYNC_XBAR0**) implements a set of multiplexers to provide selection of various events to EPWM SYNCIN, RTI Capture and DMA Trigger. There is one register per output that controls the selection (**SOC_TIMESYNC_XBAR0_MUXCNTL_y**).

The SOC_TIMESYNC_XBAR0 module has the following configuration:

- Number of input events: 22
- Number of output events: 12
- Event input type: Pulse

12.2.1.2 SOC_TIMESYNC_XBAR1 Overview

The Time Sync Event Router1 (**SOC_TIMESYNC_XBAR1**) implements a set of multiplexers to provide selection of various events to CPU Interrupts, DMA Triggers, CPTS Push events, ICSS Latch and capture events. There is one register per output that controls the selection (**SOC_TIMESYNC_XBAR1_MUXCNTL_y**).

The SOC_TIMESYNC_XBAR1 module has the following configuration:

- Number of input events: 16
- Number of output events: 34
- Event input type: Pulse

12.2.2 Time Sync Routers Integration

This section describes the Time Sync Routers integration in the device, including information about clocks, resets, and hardware requests.

12.2.2.1 SOC_TIMESYNC_XBAR0 Integration

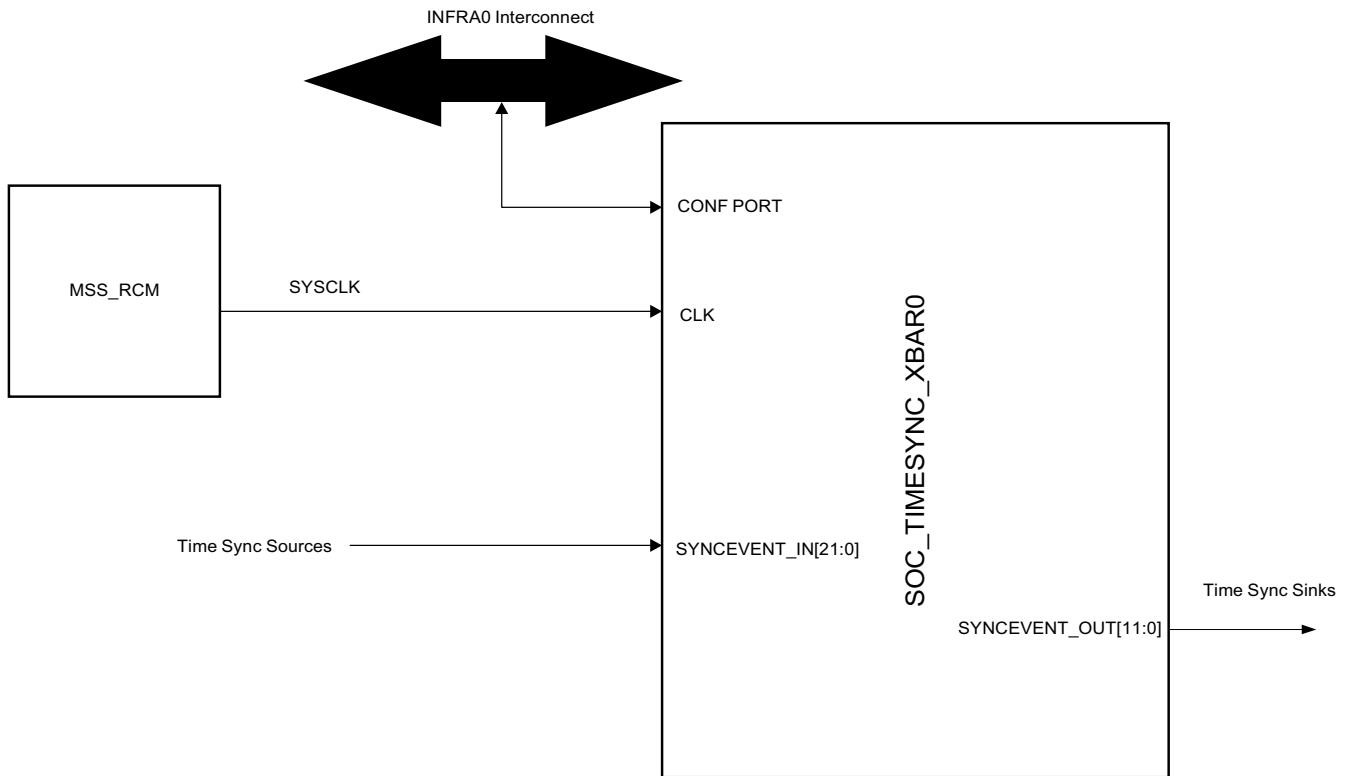

Figure 12-2. SOC_TIMESYNC_XBAR0 Integration

Table 12-2. SOC_TIMESYNC_XBAR0 Device Integration

Module Instance	Device Allocation	SoC Interconnect
SOC_TIMESYNC_XBAR0	✓	VBUSP INFRA0 Interconnect

Table 12-3. SOC_TIMESYNC_XBAR0 Clocks

Module Instance	Module Clock Input	Source Clock Signal	Source	Default Freq	Description
SOC_TIMESYNC_XBAR0	CLK	SYSCLK	MSS_RCM	200 MHz	SOC_TIMESYNC_XBAR0 Functional and Interface clock

Table 12-4. SOC_TIMESYNC_XBAR0 Resets

Module Instance	Module Reset Input	Source Reset Signal	Source	Description
SOC_TIMESYNC_XBAR0	RST	SYS_RST	RCM + Warm Reset Sources	SOC_TIMESYNC_XBAR0 Reset

ADVANCE INFORMATION

Table 12-5. SOC_TIMESYNC_XBAR0 Time Sync Output Events

Module Instance	Module Sync Output	Destination Sync Signal	Destination	Type	Description
SOC_TIMESYNC_XBAR0	SYNCEVENT_OUT0	EPWMx_SYNC IN58	EPWMx	Edge	Selectable sync event 0
	SYNCEVENT_OUT1	EPWMx_SYNC IN59	EPWMx		Selectable sync event 1
	SYNCEVENT_OUT2	CAPEVT0	RTI0,WDT0		Selectable sync event 2
	SYNCEVENT_OUT3	CAPEVT1	RTI0,WDT0		Selectable sync event 3
	SYNCEVENT_OUT4	CAPEVT0	RTI1,WDT1		Selectable sync event 4
	SYNCEVENT_OUT5	CAPEVT1	RTI1,WDT1		Selectable sync event 5
	SYNCEVENT_OUT6	CAPEVT0	RTI2,WDT2		Selectable sync event 6

Module Instance	Module Sync Input	TimeSync Event Sources
SOC_TIMESYNC_XBAR0	SYNCEVENT_IN[21:0]	See SOC_TIMESYNC_XBAR0 Event Map table for time sync event mapping.

12.2.2.2 SOC_TIMESYNC_XBAR1 Integration

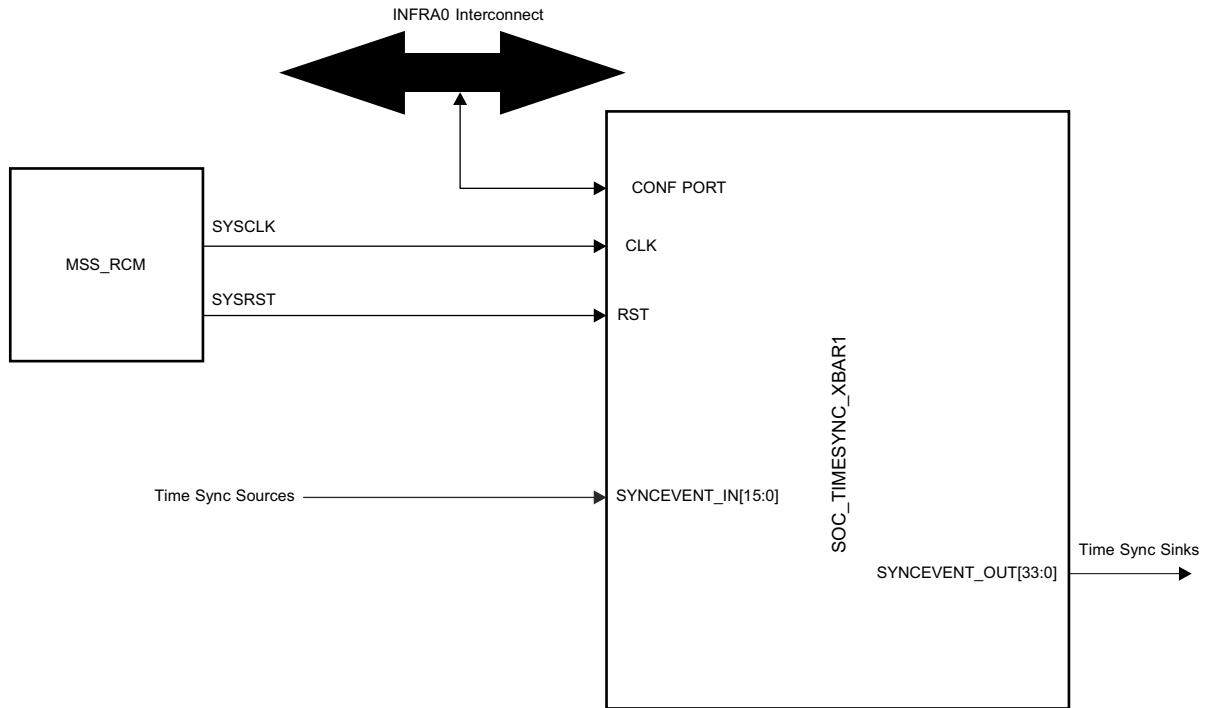

Figure 12-3. SOC_TIMESYNC_XBAR1 Integration

Table 12-6. SOC_TIMESYNC_XBAR1 Device Integration

Module Instance	Device Allocation	SoC Interconnect
SOC_TIMESYNC_XBAR1	✓	VBUSP INFRA0 Interconnect

Table 12-7. SOC_TIMESYNC_XBAR1 Clocks

Module Instance	Module Clock Input	Source Clock Signal	Source	Default Freq	Description
SOC_TIMESYNC_XBAR1	CLK	SYSCLK	MSS_RCM	200 MHz	SOC_TIMESYNC_XBAR1 Functional and Interface clock

Table 12-8. SOC_TIMESYNC_XBAR1 Resets

Module Instance	Module Reset Input	Source Reset Signal	Source	Description
SOC_TIMESYNC_XBAR1	RST	SYS_RST	RCM + Warm Reset Sources	SOC_TIMESYNC_XBAR1 Reset

Table 12-9. SOC_TIMESYNC_XBAR1 Time Sync Output Events

ModuleTime Sync Events (Outputs)					
Module Instance	Module Sync Output	Destination Sync Signal	Destination	Type	Description
SOC_TIMESYNC_XBAR1	SYNCEVENT_OUT0	EDMA_TRIGG ERXBAR_IN11 1	EDMA_TRIGG ERXBAR	Edge	Selectablesync event 0
	SYNCEVENT_OUT1	EDMA_TRIGG ERXBAR_IN11 2	EDMA_TRIGG ERXBAR		Selectablesync event 1
	SYNCEVENT_OUT2	R5SS0_CORE 0_INTR138	R5SS0_CORE 0_VIM		Selectablesync event 2
	SYNCEVENT_OUT3	R5SS0_CORE 0_INTR139	R5SS0_CORE 0_VIM		Selectablesync event 3
	SYNCEVENT_OUT4	R5SS0_CORE 0_INTR140	R5SS0_CORE 0_VIM		Selectablesync event 4
	SYNCEVENT_OUT5	R5SS0_CORE 0_INTR141	R5SS0_CORE 0_VIM		Selectablesync event 5
	SYNCEVENT_OUT6	R5SS0_CORE 1_INTR138	R5SS0_CORE 1_VIM		Selectablesync event 6
	SYNCEVENT_OUT7	R5SS0_CORE 1_INTR139	R5SS0_CORE 1_VIM		Selectablesync event 7
	SYNCEVENT_OUT8	R5SS0_CORE 1_INTR140	R5SS0_CORE 1_VIM		Selectablesync event 8
	SYNCEVENT_OUT9	R5SS0_CORE 1_INTR141	R5SS0_CORE 1_VIM		Selectablesync event 9
	SYNCEVENT_OUT10	ICSSM0_EDC_LATCH0_IN	PRU_ICSSM0		Selectablesync event 10
	SYNCEVENT_OUT11	ICSSM0_EDC_LATCH1_IN	PRU_ICSSM0		Selectablesync event 11
	SYNCEVENT_OUT12	ICSSM0_IEP_CAP_INT R0	PRU_ICSSM0		Selectablesync event 12
	SYNCEVENT_OUT13	ICSSM0_IEP_CAP_INT R1	PRU_ICSSM0		Selectablesync event 13
	SYNCEVENT_OUT14	ICSSM0_IEP_CAP_INT R2	PRU_ICSSM0		Selectablesync event 14
	SYNCEVENT_OUT15	ICSSM0_IEP_CAP_INT R3	PRU_ICSSM0		Selectablesync event 15
	SYNCEVENT_OUT16	ICSSM0_IEP_CAP_INT R4	PRU_ICSSM0		Selectablesync event 16
	SYNCEVENT_OUT17	ICSSM0_IEP_CAP_INT R5	PRU_ICSSM0		Selectablesync event 17
	SYNCEVENT_OUT18	CPTS_HW1_T S_PUSH	CPSW0_CPTS		Selectablesync event 18
	SYNCEVENT_OUT19	CPTS_HW2_T S_PUSH	CPSW0_CPTS		Selectablesync event 19
	SYNCEVENT_OUT20	CPTS_HW3_T S_PUSH	CPSW0_CPTS		Selectablesync event 20
	SYNCEVENT_OUT21	CPTS_HW4_T S_PUSH	CPSW0_CPTS		Selectablesync event 21
	SYNCEVENT_OUT22	CPTS_HW5_T S_PUSH	CPSW0_CPTS		Selectablesync event 22
	SYNCEVENT_OUT23	CPTS_HW6_T S_PUSH	CPSW0_CPTS		Selectablesync event 23
	SYNCEVENT_OUT24	CPTS_HW7_T S_PUSH	CPSW0_CPTS		Selectablesync event 24
	SYNCEVENT_OUT25	CPTS_HW8_T S_PUSH	CPSW0_CPTS		Selectablesync event 25
SYNCEVENT_OUT26	R5SS1_CORE 0_INTR138	R5SS1_CORE 0_VIM	Selectablesync event 26		
SYNCEVENT_OUT27	R5SS1_CORE 0_INTR139	R5SS1_CORE 0_VIM	Selectablesync event 27		

ADVANCE INFORMATION

Module Instance	Module Sync Input	TimeSync Event Sources
SOC_TIMESYNC_XBAR1	SYNCEVENT_IN[15:0]	See SOC_TIMESYNC_XBAR1 Event Map table for time sync event mapping.

12.2.3 Time Sync Routers Registers

12.2.3.1 SOC_TIMESYNC_XBAR0 Registers

Table 12-10. SOC_TIMESYNC_XBAR0Instances

Instance	BaseAddress
SOC_TIMESYNC_XBAR0	52E00000h

Table 12-11. SOC_TIMESYNC_XBAR0 Registers

Offset	Acronym	Register Name	Physical Address
0h	SOC_TIMESYNC_XBAR0_PID	Peripheral identification register	52E00000h
4h+ formula	SOC_TIMESYNC_XBAR0_MUX CNTL_y	Eventmux control register	52E00004h+ formula

12.2.3.2 SOC_TIMESYNC_XBAR1 Registers

Table 12-12. SOC_TIMESYNC_XBAR1Instances

Instance	Base Address
SOC_TIMESYNC_XBAR1	52E04000h

Table 12-13. SOC_TIMESYNC_XBAR1Registers

Offset	Acronym	RegisterName	Physical Address
0h	SOC_TIMESYNC_XBAR1_PID	Peripheral identification register	52E04000h
4h+ formula	SOC_TIMESYNC_XBAR1_MUX CNTL_y	Eventmux control register	52E04004h+ formula

12.3 Time Sync and Compare Events

12.3.1 TimeSync Event Sources

12.3.1.1 SOC_TIMESYNC_XBAR0 Event Map

Table 12-14 shows the mapping of events to the SOC_TIMESYNC_XBAR1. The router allows any of the inputs to be routed to the output.

Table 12-14. SOC_TIMESYNC_XBAR1 Events

Input Event	Event Number	Event Name	Description	Type
SYNCEVENT_IN0	0	CPSW0_CPTS_COMP	CPTSCompare event	Pulse
SYNCEVENT_IN1	1	CPSW0_CPTS_GENF0	CPTSGenerate function 0	Pulse
SYNCEVENT_IN2	2	CPSW0_CPTS_GENF1	CPTSGenerate function 1	Pulse
SYNCEVENT_IN3	3	CPSW0_CPTS_SYNC	CPTSSYNC Event	Pulse
SYNCEVENT_IN4	4	ICSSM_EDC_SYNC0	ICSSMIIEP Sync event0	Pulse
SYNCEVENT_IN5	5	ICSSM_EDC_SYNC1	ICSSMIIEP Sync event1	Pulse
SYNCEVENT_IN6	6	ICSSM_IIEP_CMP_EVT0	ICSSMIIEP Compare event 0	Pulse
SYNCEVENT_IN7	7	ICSSM_IIEP_CMP_EVT1	ICSSMIIEP Compare event 1	Pulse
SYNCEVENT_IN8	8	ICSSM_IIEP_CMP_EVT2	ICSSMIIEP Compare event 2	Pulse
SYNCEVENT_IN9	9	ICSSM_IIEP_CMP_EVT3	ICSSMIIEP Compare event 3	Pulse
SYNCEVENT_IN10	10	ICSSM_IIEP_CMP_EVT4	ICSSMIIEP Compare event 4	Pulse
SYNCEVENT_IN11	11	ICSSM_IIEP_CMP_EVT5	ICSSMIIEP Compare event 5	Pulse
SYNCEVENT_IN12	12	ICSSM_IIEP_CMP_EVT6	ICSSMIIEP Compare event 6	Pulse
SYNCEVENT_IN13	13	ICSSM_IIEP_CMP_EVT7	ICSSMIIEP Compare event 7	Pulse
SYNCEVENT_IN14	14	ICSSM_IIEP_CMP_EVT8	ICSSMIIEP Compare event 8	Pulse
SYNCEVENT_IN15	15	ICSSM_IIEP_CMP_EVT9	ICSSMIIEP Compare event 9	Pulse
SYNCEVENT_IN16	16	ICSSM_IIEP_CMP_EVT10	ICSSMIIEP Compare event 10	Pulse
SYNCEVENT_IN17	17	ICSSM_IIEP_CMP_EVT11	ICSSMIIEP Compare event 11	Pulse
SYNCEVENT_IN18	18	ICSSM_IIEP_CMP_EVT12	ICSSMIIEP Compare event 12	Pulse
SYNCEVENT_IN19	19	ICSSM_IIEP_CMP_EVT13	ICSSMIIEP Compare event 13	Pulse
SYNCEVENT_IN20	20	ICSSM_IIEP_CMP_EVT14	ICSSMIIEP Compare event 14	Pulse
SYNCEVENT_IN21	21	ICSSM_IIEP_CMP_EVT15	ICSSMIIEP Compare event 15	Pulse

12.3.1.2 SOC_TIMESYNC_XBAR1 Event Map

Table 12-15 shows the mapping of events to the SOC_TIMESYNC_XBAR1. The router allows any of the inputs to be routed to the output.

Table 12-15. SOC_TIMESYNC_XBAR1 Events

Input Event	Event Number	Event Name	Description	Type
SYNCEVENT_IN0	0	CPSW0_CPTS_COMP	CPTSCOMPARE event	Pulse
SYNCEVENT_IN1	1	CPSW0_CPTS_GENF0	CPTSGENERATE function 0	Pulse
SYNCEVENT_IN2	2	CPSW0_CPTS_GENF1	CPTSGENERATE function 1	Pulse
SYNCEVENT_IN3	3	CPSW0_CPTS_SYNC	CPTSSYNC Event	Pulse
SYNCEVENT_IN4	4	ICSSM_EDC_SYNC0	ICSSMIEP Sync event0	Pulse
SYNCEVENT_IN5	5	ICSSM_EDC_SYNC1	ICSSMIEP Sync event1	Pulse
SYNCEVENT_IN6	6	CONTROLSS_PWMSYN COUT_XBAR_OUT0	EPWMSYNCOU from PWM SyncoutXbar	Pulse
SYNCEVENT_IN7	7	CONTROLSS_PWMSYN COUT_XBAR_OUT1	EPWMSYNCOU from PWM SyncoutXbar	Pulse
SYNCEVENT_IN8	8	CONTROLSS_PWMSYN COUT_XBAR_OUT2	EPWMSYNCOU from PWM SyncoutXbar	Pulse
SYNCEVENT_IN9	9	CONTROLSS_PWMSYN COUT_XBAR_OUT3	EPWMSYNCOU from PWM SyncoutXbar	Pulse
SYNCEVENT_IN10	10	GPIO_INTER_XBAR_OU T8	GPIOINTERRUPT from GPIO InterruptXbar	Pulse
SYNCEVENT_IN11	11	GPIO_INTER_XBAR_OU T9	GPIOINTERRUPT from GPIO InterruptXbar	Pulse
SYNCEVENT_IN12	12	GPIO_INTER_XBAR_OU T10	GPIOINTERRUPT from GPIO InterruptXbar	Pulse
SYNCEVENT_IN13	13	GPIO_INTER_XBAR_OU T11	GPIOINTERRUPT from GPIO InterruptXbar	Pulse
SYNCEVENT_IN14	14	GPIO_INTER_XBAR_OU T12	GPIOINTERRUPT from GPIO InterruptXbar	Pulse
SYNCEVENT_IN15	15	GPIO_INTER_XBAR_OU T13	GPIOINTERRUPT from GPIO InterruptXbar	Pulse

12.3.1.3 ICSSM Event Map

Table 12-16 shows the mapping of events to the ICSSM Latch and Compare inputs.

Table 12-16. ICSSM Event Map

Input Event	Event Name	Type	Description
ICSSM0_EDC_LATCH0_IN	SOC_TIMESYNC_XBAR1_SYNCEVE NT_OUT10	Edge	Selectable sync event 10
ICSSM0_EDC_LATCH1_IN	SOC_TIMESYNC_XBAR1_SYNCEVE NT_OUT11		Selectable sync event 11

Table 12-16. ICSSM Event Map (continued)

Input Event	Event Name	Type	Description
ICSSM0_IEP_CAP_INTR0	SOC_TIMESYNC_XBAR1_SYNCEVE NT_OUT12	Pulse	Selectable sync event 12
ICSSM0_IEP_CAP_INTR1	SOC_TIMESYNC_XBAR1_SYNCEVE NT_OUT13		Selectable sync event 13
ICSSM0_IEP_CAP_INTR2	SOC_TIMESYNC_XBAR1_SYNCEVE NT_OUT14		Selectable sync event 14
ICSSM0_IEP_CAP_INTR3	SOC_TIMESYNC_XBAR1_SYNCEVE NT_OUT15		Selectable sync event 15
ICSSM0_IEP_CAP_INTR4	SOC_TIMESYNC_XBAR1_SYNCEVE NT_OUT16		Selectable sync event 16
ICSSM0_IEP_CAP_INTR5	SOC_TIMESYNC_XBAR1_SYNCEVE NT_OUT17		Selectable sync event 17

12.3.1.4 CPSW0_CPTS Event Map

Table 12-17 shows the mapping of events to the CPSW0_CPTS Hardware push inputs.

Table 12-17. CPSW0_CPTS Event Map

Input Event	Event Name	Description	Type
CPTS_HW1_TS_PUSH	SOC_TIMESYNC_XBAR1_SYN CEVE NT_OUT18	Selectablesync event 18	Pulse
CPTS_HW2_TS_PUSH	SOC_TIMESYNC_XBAR1_SYN CEVE NT_OUT19	Selectablesync event 19	Pulse
CPTS_HW3_TS_PUSH	SOC_TIMESYNC_XBAR1_SYN CEVE NT_OUT20	Selectablesync event 20	Pulse
CPTS_HW4_TS_PUSH	SOC_TIMESYNC_XBAR1_SYN CEVE NT_OUT21	Selectablesync event 21	Pulse
CPTS_HW5_TS_PUSH	SOC_TIMESYNC_XBAR1_SYN CEVE NT_OUT22	Selectablesync event 22	Pulse
CPTS_HW6_TS_PUSH	SOC_TIMESYNC_XBAR1_SYN CEVE NT_OUT23	Selectablesync event 23	Pulse
CPTS_HW7_TS_PUSH	SOC_TIMESYNC_XBAR1_SYN CEVE NT_OUT24	Selectablesync event 24	Pulse
CPTS_HW8_TS_PUSH	SOC_TIMESYNC_XBAR1_SYN CEVE NT_OUT25	Selectablesync event 25	Pulse



This chapter describes the various peripheral modules instantiated in the device.

13.1 General Connectivity Peripherals

This section describes the general connectivity peripherals in the device.



13.1.1 General-Purpose Interface (GPIO)

This chapter describes the General-Purpose Input/Output (GPIO) for the device.

13.1.1.1 GPIO Overview.....	884
13.1.1.2 GPIO Environment.....	885
13.1.1.3 GPIO Integration.....	886
13.1.1.4 GPIO Functional Description.....	891

13.1.1.1 GPIO Overview

The General-Purpose Input/Output (GPIO) peripheral provides dedicated general-purpose pins that can be configured as either inputs or outputs. When configured as an output, the user can write to an internal register to control the state driven on the output pin. When configured as an input, user can obtain the state of the input by reading the state of an internal register.

In addition, the GPIO peripheral can produce host CPU interrupts and DMA synchronization events in different interrupt/event generation modes.

The device has four instances of the GPIO module, one per R5FSS processor core. The GPIO pins are grouped into banks (16 pins per bank and 9 banks per module), which means that each GPIO module provides up to 144 dedicated general-purpose pins with input and output capabilities.

Table 13-1 shows GPIO modules allocation within device domains.

Table 13-1. GPIO Modules Allocation within Device Domains

Module Instance	Device
GPIO0	✓ (R5FSS0-CORE0)
GPIO1	✓ (R5FSS0-CORE1)
GPIO2	✓ (R5FSS1-CORE0)
GPIO3	✓ (R5FSS1-CORE1)

13.1.1.2 GPIO Environment

The GPIO[0-3] modules are hereinafter referred to as GPIO module.

This section describes the GPIO external connections (environment).

The general-purpose interface combines three GPIO modules for a flexible, user-programmable, general-purpose input/output (I/O) controller. The general-purpose interface implements functions that are not implemented with the dedicated controllers in the device and require simple input and/or output software-controlled signals. The GPIO allows a variety of custom connections and expands the I/O capabilities of the system to the real world.

The general-purpose interface can physically connect the device to a keyboard matrix and peripheral integrated circuits (ICs).

13.1.1.3 GPIO Integration

This section describes modules integration in the device, including information about clocks, resets, and hardware requests.

GPIO Integration

There are 4x GPIO modules integrated in the device. The diagram below provides a visual representation of the device integration details.

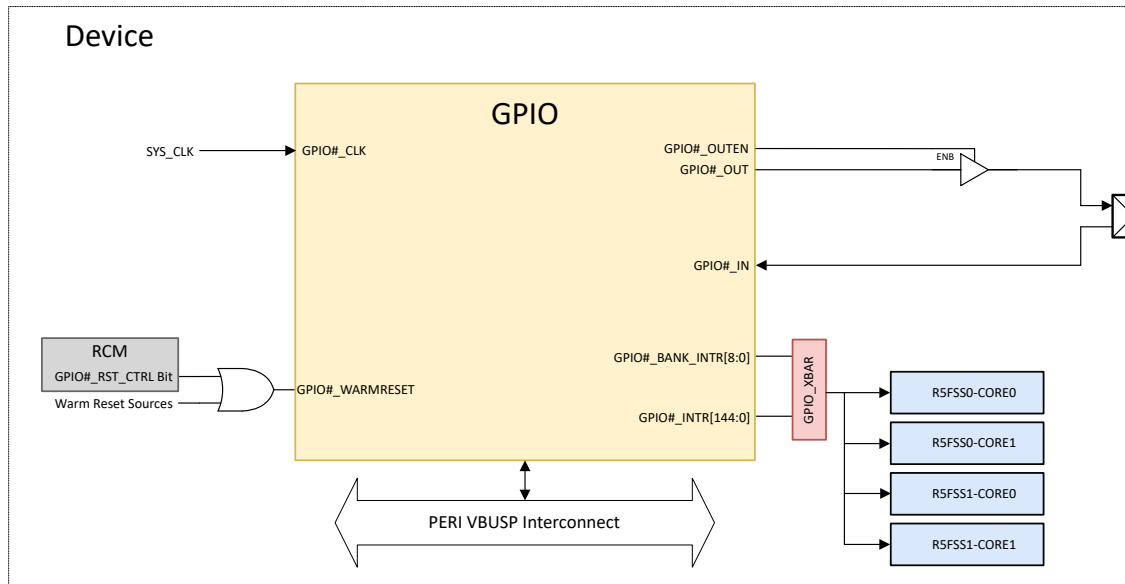

ADVANCE INFORMATION

Figure 13-1. GPIO Integration Diagram

Note

There is a designated GPIO module per R5FSS core. Each R5FSS core has access to all GPI signals. The GPO signals can be assigned to a specific R5FSS core by configuring the `MSS_IOMUX.PAD_CFG_REG.GPIO_SEL[17:16]` of the associated IOMUX Pad Configuration register.

This diagram describes the GPIO multiplexor connectivity.

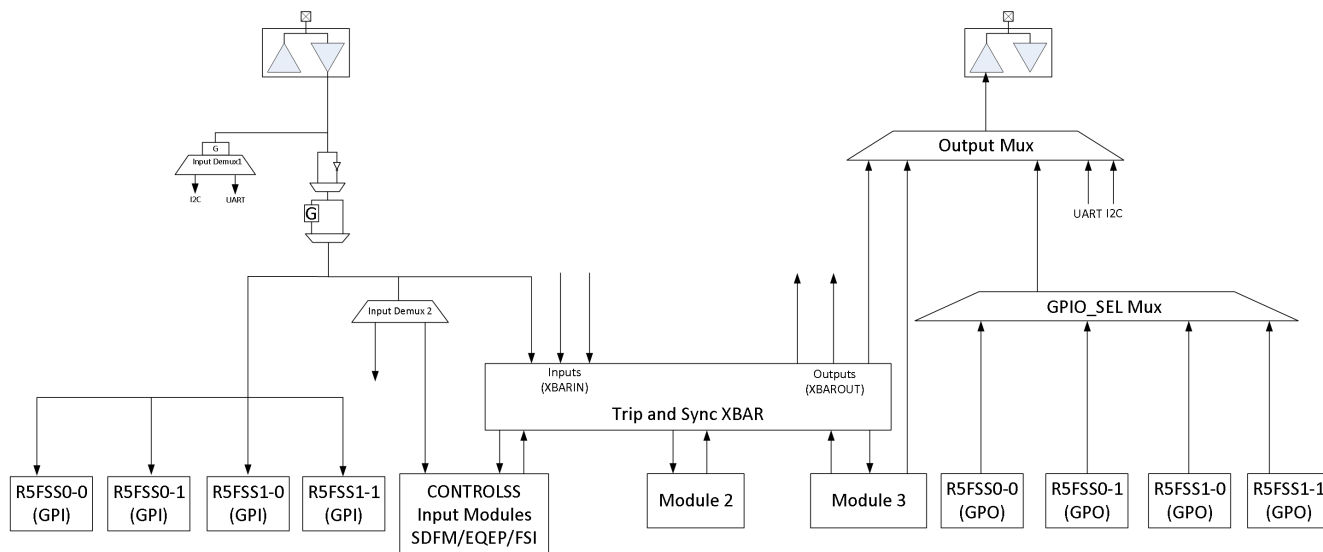

Figure 13-2. GPIO Mux Diagram

The tables below summarize the device integration details of GPIO# (where # = 0 to 4).

Table 13-2. GPIO Device Integration

This table describes the module device integration details.

Module Instance	Device Allocation	SoC Interconnect
GPIO0	✓	PERI VBUSP Interconnect
GPIO1	✓	PERI VBUSP Interconnect
GPIO2	✓	PERI VBUSP Interconnect
GPIO3	✓	PERI VBUSP Interconnect

Table 13-3. GPIO Clocks

This table describes the module clocking signals.

Module Instance	Module Clock Input	Source Clock Signal	Source	Default Freq	Description
GPIO0	GPIO0_VBUS_FICLK	SYS_CLK	PLL_CORE_CLK:HSDIV0_CLKOUT0	200 MHz	GPIO0 Functional and Interface Clock
GPIO1	GPIO1_VBUS_FICLK	SYS_CLK	PLL_CORE_CLK:HSDIV0_CLKOUT0	200 MHz	GPIO1 Functional and Interface Clock
GPIO2	GPIO2_VBUS_FICLK	SYS_CLK	PLL_CORE_CLK:HSDIV0_CLKOUT0	200 MHz	GPIO2 Functional and Interface Clock
GPIO3	GPIO3_VBUS_FICLK	SYS_CLK	PLL_CORE_CLK:HSDIV0_CLKOUT0	200 MHz	GPIO3 Functional and Interface Clock

Table 13-4. GPIO Resets

This table describes the module reset signals.

Module Instance	Module Reset Input	Source Reset Signal	Source	Description
GPIO0	GPIO0_RST	Warm Reset (MOD_G_RST)	RCM + Warm Reset Sources	GPIO0 Reset
GPIO1	GPIO1_RST	Warm Reset (MOD_G_RST)	RCM + Warm Reset Sources	GPIO1 Reset
GPIO2	GPIO2_RST	Warm Reset (MOD_G_RST)	RCM + Warm Reset Sources	GPIO2 Reset

Table 13-4. GPIO Resets (continued)

This table describes the module reset signals.

Module Instance	Module Reset Input	Source Reset Signal	Source	Description
GPIO3	GPIO3_RST	Warm Reset (MOD_G_RST)	RCM + Warm Reset Sources	GPIO3 Reset

Table 13-5. GPIO Interrupt Requests

This table describes the module interrupt requests.

Module Instance	Module Interrupt Signal	Destination Interrupt Input	Destination	Type	Description
GPIOx	GPIOx_[0:137]	Programmable via GPIO_XBAR_INTR0	GPIO_XBAR_I NTR0	Pulse	GPIOx_[0:137] interrupt request
GPIOx	GPIOx_BANK0_INT	Programmable via GPIO_XBAR_INTR0	GPIO_XBAR_I NTR0	Pulse	GPIOx BANK0 interrupt request
GPIOx	GPIOx_BANK1_INT	Programmable via GPIO_XBAR_INTR0	GPIO_XBAR_I NTR0	Pulse	GPIOx BANK1 interrupt request
GPIOx	GPIOx_BANK2_INT	Programmable via GPIO_XBAR_INTR0	GPIO_XBAR_I NTR0	Pulse	GPIOx BANK2 interrupt request
GPIOx	GPIOx_BANK3_INT	Programmable via GPIO_XBAR_INTR0	GPIO_XBAR_I NTR0	Pulse	GPIOx BANK3 interrupt request
GPIOx	GPIOx_BANK4_INT	Programmable via GPIO_XBAR_INTR0	GPIO_XBAR_I NTR0	Pulse	GPIOx BANK4 interrupt request
GPIOx	GPIOx_BANK5_INT	Programmable via GPIO_XBAR_INTR0	GPIO_XBAR_I NTR0	Pulse	GPIOx BANK5 interrupt request
GPIOx	GPIOx_BANK6_INT	Programmable via GPIO_XBAR_INTR0	GPIO_XBAR_I NTR0	Pulse	GPIOx BANK6 interrupt request
GPIOx	GPIOx_BANK7_INT	Programmable via GPIO_XBAR_INTR0	GPIO_XBAR_I NTR0	Pulse	GPIOx BANK7 interrupt request
GPIOx	GPIOx_BANK8_INT	Programmable via GPIO_XBAR_INTR0	GPIO_XBAR_I NTR0	Pulse	GPIOx BANK8 interrupt request

Note

Where x = 0 to 3

Table 13-6. GPIO DMA Requests

This table describes the module DMA requests.

Module Instance	Module DMA Event	Destination DMA Event Input	Destination	Type	Description
GPIOx	N/A	N/A	N/A	N/A	The GPIO module does not support DMA requests.

Table 13-7. GPIO Capture Event Inputs

This table describes the module capture event inputs.

Module Instance	Module Capture Event Input	Capture Event Source Signal	Source	Type	Description
GPIOx	N/A	N/A	N/A	N/A	The GPIO module does not support Capture Event Inputs

Note

For more information on the interconnects, see the *System Interconnect* chapter.

For more information on power, reset, and clock management, see the corresponding sections within the *Device Configuration* chapter.

For more information on the device interrupt controllers, see the *Interrupt Controllers* chapter.

13.1.1.4 GPIO Functional Description

13.1.1.4.1 GPIO Block Diagram

Figure 13-3 shows the general-purpose interface block diagram.

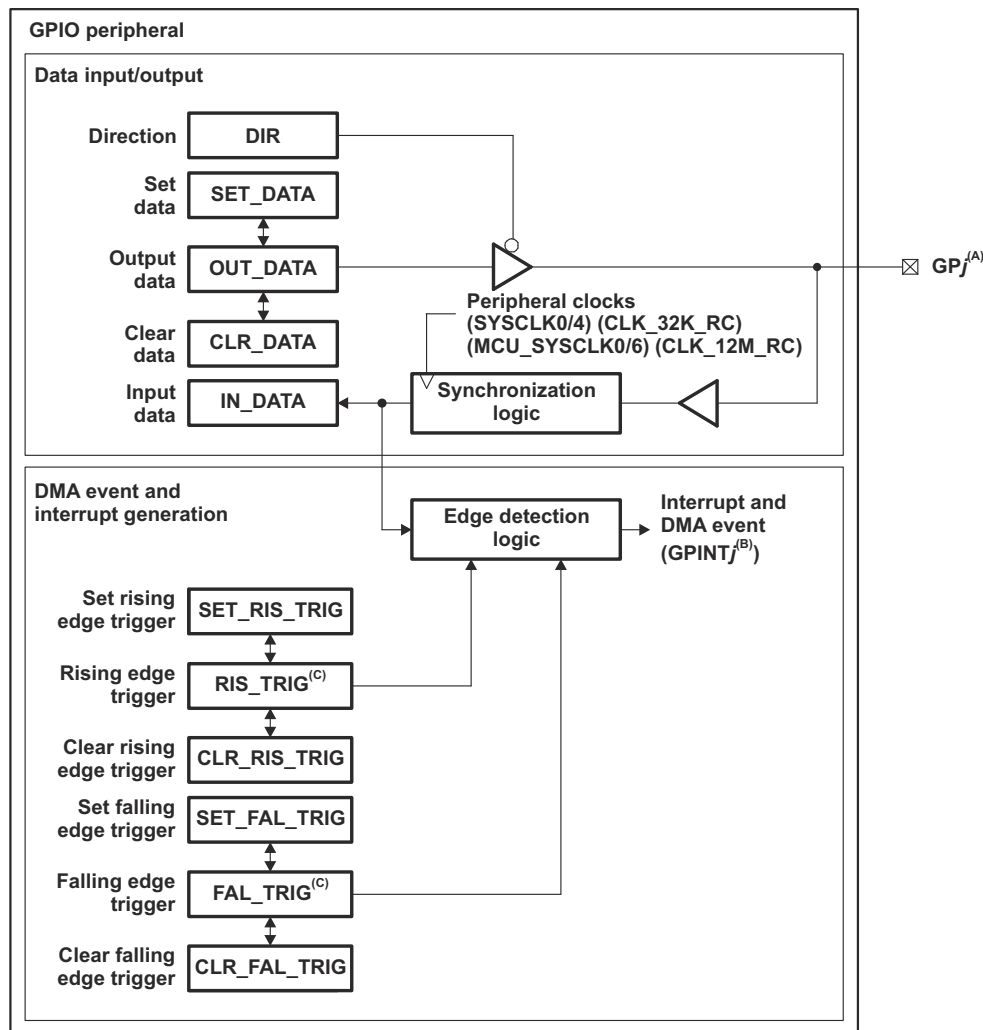

gpio_005

- A. Some of the GPj pins are muxed with other device signals. For details, see the device-specific Datasheet.
- B. All GPINTj can be used as host CPU interrupts and synchronization events to the DMA.
- C. The RIS_TRIG and FAL_TRIG registers are internal to the GPIO module and are not visible to the host CPU.

Figure 13-3. GPIO Block Diagram

13.1.1.4.2 GPIO Function

Each GPIO pin (GPj) can be independently configured as either an input or an output using the GPIO direction registers. The GPIO direction register (DIR) specifies the direction of each GPIO signal. Logic 0 indicates the GPIO pin is configured as output, and logic 1 indicates input.

When configured as output, writing a 0x1 to a bit in the set data register drives the corresponding GPj to a logic-high state. Writing a 0x1 to a bit in the clear data register drives the corresponding GPj to a logic-low state. The output state of each GPj can also be directly controlled by writing to the output data register.

For example, to set GP8 to a logic-high state, the software can perform one of the following:

- Write 100h to the GPIO_SET_DATA01 register.
- Write 0h to the GPIO_DIR01 register to configure as output pin.

- Read in GPIO_OUT_DATA01 register, change bit 8 to 0x1, and write the new value back to GPIO_OUT_DATA01.

To set GP8 to a logic-low state, the software can perform one of the following:

- Write 100h to the GPIO_CLR_DATA01 register.
- Write 0h to the GPIO_DIR01 register to configure as output pin.
- Read in GPIO_OUT_DATA01 register, change bit 8 to 0x0, and write the new value back to GPIO_OUT_DATA01.

Note that writing a 0x0 to bits in the set data and clear data registers does not affect the GPIO pin state.

Also, for GPIO pins configured as input, writing to the set data, clear data, or output data registers does not affect the pin state.

For a GPIO pin configured as input, reading the input data register (IN_DATA) will return the pin state. Reading the SET_DATA register or the CLR_DATA data register will return the value in OUT_DATA, not the actual pin state. The pin state is available by reading the input data register. Note that when the direction is configured as input, the output state is determined by software's programming set/clear/output registers, and may not agree with the pin state, which is driven by an external device.

13.1.1.4.3 GPIO Interrupt and Event Generation

Each GPIO pin (GPj) can be configured to generate a host CPU interrupt (GPINTj) or a synchronization event to the DMA (GPINTj). Configuration is on per-bank basis. Each bit of the BINT_EN parameter dictates YES/NO option for each bank. Bit 0 controls bank 0, bit 1 controls bank 1, and so on.

The interrupt and DMA event can be generated on the rising-edge, falling-edge, or on both edges of the GPIO signal. The edge detection logic is synchronized to the GPIO peripheral clock.

The direction of the GPIO pin does not need to be input when using the pin to generate the interrupt or DMA event. When the GPIO pin is configured as input, transitions on the pin trigger interrupts or DMA events. When the GPIO pin is configured as output, software can toggle the GPIO output register to change the pin state and in turn trigger the interrupt or DMA event.

Note that the direction of the pin need not be input for interrupt generation to work. When the GPINT pin is configured as input, transitions on the pin trigger interrupts. When the GPINT pin is configured as output, firmware can toggle the GPIO output register to change the pin state, and in turn trigger interrupts.

Each interrupt output of GPINT signal are available at the module boundary. Each group of 16 GPINT signals also has their masked interrupt outputs ORed together to generate a per bank interrupt, available at the module boundary. The idea is to either connect individual interrupts or per bank interrupts to the system interrupt controller.

13.1.1.4.3.1 Interrupt Enable (per Bank)

The GPIO_BINTEN register provides interrupt enable/disable feature for each bank of 16 GPINT signals.

13.1.1.4.3.2 Trigger Configuration (per Bit)

Two internal registers, RIS_TRIG and FAL_TRIG, specify which edge of the GPj signal generates an interrupt or DMA event. Each bit in these two registers corresponds to a GPj pin. [Table 13-8](#) describes the host CPU interrupt and DMA event generation of GPj pin based on the bit settings of the RIS_TRIG and FAL_TRIG registers.

Table 13-8. GPIO Interrupt and DMA Event Configuration Options

RIS_TRIG Bit n	FAL_TRIG Bit n	Host CPU Interrupt and DMA Event Generation
0	0	GPINTj interrupt and DMA event is disabled
0	1	GPINTj interrupt and DMA event is triggered on falling edge of GPj signal
1	0	GPINTj interrupt and DMA event is triggered on rising edge of GPj signal
1	1	GPINTj interrupt and DMA event is triggered on both rising and falling edge of GPj signal

The RIS_TRIG and FAL_TRIG registers are not directly accessible or visible to the host CPU. These registers are accessed indirectly through four registers: SET_RIS_TRIG, CLR_RIS_TRIG, SET_FAL_TRIG, and CLR_FAL_TRIG. Writing 1 to a bit on the SET_RIS_TRIG register sets the corresponding bit on the RIS_TRIG register. Writing 1 to a bit of the CLR_RIS_TRIG register clears the corresponding bit on the RIS_TRIG register. Writing to the SET_FAL_TRIG and CLR_FAL_TRIG registers works the same way on the FAL_TRIG register.

Reading the SET_RIS_TRIG or CLR_RIS_TRIG register returns the value of the RIS_TRIG register. Reading from the SET_FAL_TRIG and CLR_FAL_TRIG register returns the value of the FAL_TRIG register.

To use the GPIO pins as sources for host CPU interrupts and DMA events, bit 0 in the bank interrupt enable register (GPIO_BINTEN) must be set to 1.

13.1.1.4.3.3 Interrupt Status and Clear (per Bit)

The INTSTAT registers provide interrupt status upon reading, and interrupt clear feature upon writing 1 to the corresponding bit position(s). Upon receiving an interrupt, the ISR can examine the interrupt status and clear the processed interrupts.

Note

The GPIO module generates an interrupt pulse on the individual GPINT interrupt in response to each occurrence of the specified edge condition. Therefore, for GPINT signals having their interrupts routed directly to the interrupt controller, it is not necessary to clear the status bits in this module. The interrupt status and clear register is a facility for the per-bank interrupt connection.

13.1.1.4.4 Input Qualification

The input qualification scheme has been designed to be very flexible. You can select the type of input qualification for each GPIO pin by configuring the IOMUX.*_CFG_REG[QUAL_SEL] registers. In the case of a GPIO input pin, the qualification can be specified as only synchronize to SYSCLK or qualification by a sampling window. For pins that are configured as peripheral inputs, the input can also be asynchronous in addition to synchronized to SYSCLK or qualified by a sampling window. The remainder of this section describes the options available.

13.1.1.4.4.1 No Synchronization (Asynchronous Input)

This mode is used for peripherals where input synchronization is not required or the peripheral itself performs the synchronization. Examples include communication ports UART, SPI, and I²C.

The asynchronous option is not valid if the pin is used as a general purpose digital input pin (GPIO). If the pin is configured as a GPIO input and the asynchronous option is selected then the qualification defaults to synchronization to SYSCLK as described in [Section 13.1.1.4.4.2](#).

Note

Using input synchronization when the peripheral itself performs the synchronization can cause unexpected results. The user must make sure that the GPIO pin is configured for asynchronous in this case.

13.1.1.4.4.2 Synchronization to SYSCLK Only

This is the default qualification mode of all the pins at reset. In this mode, the input signal is only synchronized to the system clock (SYSCLK). Because the incoming signal is asynchronous, a SYSCLK period of delay can be needed for the input to the device to be changed. No further qualification is performed on the signal.

13.1.1.4.4.3 Qualification Using a Sampling Window

In this mode, the signal is first synchronized to the system clock (SYSCLK) and then qualified by a specified number of cycles before the input is allowed to change. [Figure 13-4](#) and [Figure 13-5](#) show how the input qualification is performed to eliminate unwanted noise. Two parameters are specified by the user for this type of qualification: 1) the sampling period, or how often the signal is sampled, and 2) the number of samples to be taken.

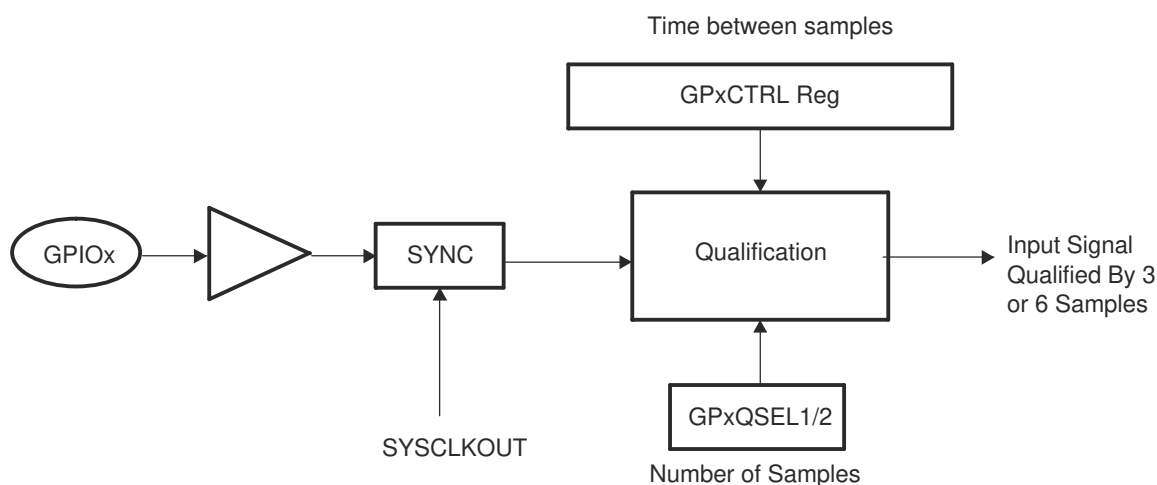

Figure 13-4. Input Qualification Using a Sampling Window

Note

For AM263x, GPxCTRL Reg = IOMUX.QUAL_GRP_*_CFG_REG[QUAL_PERIOD_PER_SAMPLE] and GPxQSEL 1/2 = IOMUX.*_CFG_REG[QUAL_SEL] in the diagram above.

Time between samples (sampling period):

To qualify the signal, the input signal is sampled at a regular period. The sampling period is specified by the user and determines the time duration between samples, or how often the signal is sampled, relative to the CPU clock (SYSCLK).

The sampling period is specified by the qualification period (QUALPRDn) bits in the GPxCTRL register. The sampling period is configurable in groups of 8 input signals. For example, GPIO0 to GPIO7 use GPaCTRL[QUALPRD0] setting and GPIO8 to GPIO15 use GPaCTRL[QUALPRD1]. [Table 13-9](#) and [Table 13-10](#) show the relationship between the sampling period or sampling frequency and the IOMUX.QUAL_GRP_*_CFG_REG[QUAL_PERIOD_PER_SAMPLE] setting.

Table 13-9. Sampling Period

Sampling Period	
If IOMUX.QUAL_GRP_*_CFG_REG[QUAL_PERIOD_PER_SAMPLE] = 0	$1 \times T_{\text{SYSCLK}}$
If IOMUX.QUAL_GRP_*_CFG_REG[QUAL_PERIOD_PER_SAMPLE] \neq 0	$2 \times \text{IOMUX.QUAL_GRP_*_CFG_REG[QUAL_PERIOD_PER_SAMPLE]} \times T_{\text{SYSCLK}}$
Where T_{SYSCLK} is the period in time of SYSCLK	

Table 13-10. Sampling Frequency

Sampling Frequency	
If IOMUX.QUAL_GRP_*_CFG_REG[QUAL_PERIOD_PER_SAMPLE] = 0	f_{SYSCLK}
If IOMUX.QUAL_GRP_*_CFG_REG[QUAL_PERIOD_PER_SAMPLE] \neq 0	$f_{\text{SYSCLK}} \times 1 \div (2 \times \text{IOMUX.QUAL_GRP_*_CFG_REG[QUAL_PERIOD_PER_SAMPLE]})$
Where f_{SYSCLK} is the frequency of SYSCLK	

From these equations, the minimum and maximum time between samples can be calculated for a given SYSCLK frequency:

Example: Maximum Sampling Frequency:

If IOMUX.QUAL_GRP_*_CFG_REG[QUAL_PERIOD_PER_SAMPLE] = 0

then the sampling frequency is f_{SYSCLK}

If, for example, $f_{\text{SYSCLK}} = 200 \text{ MHz}$

then the signal is sampled at 200 MHz or one sample every 5 ns.

Example: Minimum Sampling Frequency:

If IOMUX.QUAL_GRP_*_CFG_REG[QUAL_PERIOD_PER_SAMPLE] = 0xFF (255)

then the sampling frequency is $f_{\text{SYSCLK}} \times 1 \div (2 \times \text{IOMUX.QUAL_GRP_*_CFG_REG[QUAL_PERIOD_PER_SAMPLE]})$

If, for example, $f_{\text{SYSCLK}} = 200 \text{ MHz}$

then the signal is sampled at $200 \text{ MHz} \times 1 \div (2 \times 255)$ (392.157 kHz) or one sample every 2.5 μs .

Number of samples:

The number of times the signal is sampled is either three samples or six samples as specified in the qualification selection IOMUX.*_CFG_REG[QUAL_SEL] registers. When three or six consecutive cycles are the same, then the input change is passed through to the device.

Total Sampling Window Width:

The sampling window is the time during which the input signal is sampled as shown in [Figure 13-5](#). By using the equation for the sampling period, along with the number of samples to be taken, the total width of the window can be determined.

For the input qualifier to detect a change in the input, the level of the signal must be stable for the duration of the sampling window width or longer.

The number of sampling periods within the window is always one less than the number of samples taken. For a three-sample window, the sampling window width is two sampling periods wide where the sampling period is defined in [Table 13-9](#). Likewise, for a six-sample window, the sampling window width is five sampling periods wide. [#unique_1112/unique_1112_Connect_42_THREE_SAMPLEreferenceTitle](#) and [#unique_1112/unique_1112_Connect_42_SIX_SAMPLEreferenceTitle](#) show the calculations that can be used to determine the total sampling window width based on IOMUX.QUAL_GRP.*_CFG_REG[QUAL_PERIOD_PER_SAMPLE] and the number of samples taken.

Table 13-11. Case 1: Three-Sample Sampling Window Width

Total Sampling Window Width	
If IOMUX.QUAL_GRP.*_CFG_REG[QUAL_PERIOD_PER_SAMPLE] = 0	$2 \times T_{\text{SYSCLK}}$
If IOMUX.QUAL_GRP.*_CFG_REG[QUAL_PERIOD_PER_SAMPLE] \neq 0	$2 \times 2 \times \text{IOMUX.QUAL_GRP.*_CFG_REG[QUAL_PERIOD_PER_SAMPLE]} \times T_{\text{SYSCLK}}$
Where T_{SYSCLK} is the period in time of SYSCLK	

Table 13-12. Case 2: Six-Sample Sampling Window Width

Total Sampling Window Width	
If IOMUX.QUAL_GRP.*_CFG_REG[QUAL_PERIOD_PER_SAMPLE] = 0	$5 \times T_{\text{SYSCLK}}$
If IOMUX.QUAL_GRP.*_CFG_REG[QUAL_PERIOD_PER_SAMPLE] \neq 0	$5 \times 2 \times \text{IOMUX.QUAL_GRP.*_CFG_REG[QUAL_PERIOD_PER_SAMPLE]} \times T_{\text{SYSCLK}}$
Where T_{SYSCLK} is the period in time of SYSCLK	

Note

The external signal change is asynchronous with respect to both the sampling period and SYSCLK. Due to the asynchronous nature of the external signal, the input must be held stable for a time greater than the sampling window width to make sure the logic detects a change in the signal. The extra time required can be up to an additional sampling period + T_{SYSCLK} .

The required duration for an input signal to be stable for the qualification logic to detect a change is described in the data sheet.

Example Qualification Window:

For the example shown in Figure 13-5, the input qualification has been configured as follows:

- IOMUX.*_CFG_REG[QUAL_SEL] = 1,0. This indicates a six-sample qualification.
- IOMUX.QUAL_GRP_*_CFG_REG[QUAL_PERIOD_PER_SAMPLE] = 1. The sampling period is $t_w(SP) = 2 \times \text{IOMUX.QUAL_GRP_*_CFG_REG[QUAL_PERIOD_PER_SAMPLE]} \times T_{\text{SYSCLK}} = 2 \times T_{\text{SYSCLK}}$.

This configuration results in the following:

- The width of the sampling window is:

$$t_w(\text{IQSW}) = 5 \times t_w(\text{SP}) = 5 \times 2 \times \text{IOMUX.QUAL_GRP_*_CFG_REG[QUAL_PERIOD_PER_SAMPLE]} \times T_{\text{SYSCLK}} = 5 \times 2 \times T_{\text{SYSCLK}}$$

- If, for example, $T_{\text{SYSCLK}} = 5 \text{ ns}$, then the duration of the sampling window is:

Sampling period, $t_w(\text{SP}) = 2 \times T_{\text{SYSCLK}} = 2 \times 5 \text{ ns} = 10 \text{ ns}$

Sampling window, $t_w(\text{IQSW}) = 5 \times t_w(\text{SP}) = 5 \times 5 \text{ ns} = 25 \text{ ns}$

- To account for the asynchronous nature of the input relative to the sampling period and SYSCLK, up to a single additional sampling period and SYSCLK period is required to detect a change in the input signal. For this example:

$$t_w(\text{IQSW}) + t_w(\text{SP}) + T_{\text{SYSCLK}} = 25 \text{ ns} + 10 \text{ ns} + 5 \text{ ns} = 40 \text{ ns}$$

- In Figure 13-5, the glitch (A) is shorter than the qualification window and is ignored by the input qualifier.

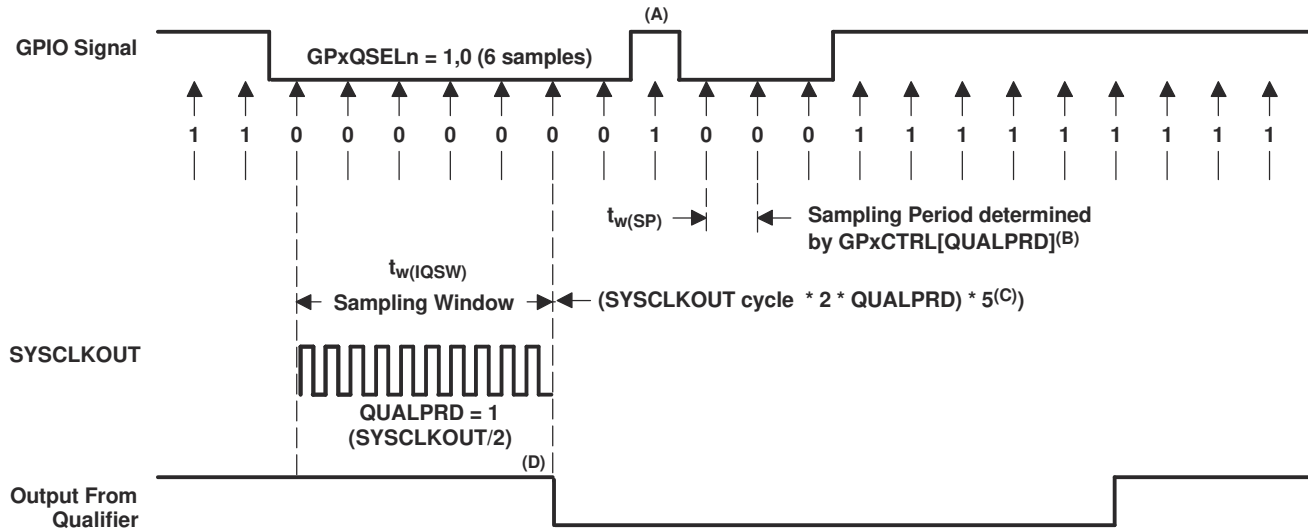

- This glitch will be ignored by the input qualifier. The QUALPRD bit field specifies the qualification sampling period. It can vary from 00 to 0xFF. If QUALPRD = 00, then the sampling period is 1 SYSCLKOUT cycle. For any other value "n", the qualification sampling period is 2n SYSCLKOUT cycles (i.e., at every 2n SYSCLKOUT cycles, the GPIO pin will be sampled).
- The qualification period selected via the GPxCTRL register applies to groups of 8 GPIO pins.
- The qualification block can take either three or six samples. The GPxQSELn Register selects which sample mode is used.
- In the example shown, for the qualifier to detect the change, the input should be stable for 10 SYSCLKOUT cycles or greater. In other words, the inputs should be stable for $(5 \times \text{QUALPRD} \times 2) \text{ SYSCLKOUT}$ cycles. That would ensure 5 sampling periods for detection to occur. Since external signals are driven asynchronously, a 13-SYSCLKOUT-wide pulse ensures reliable recognition.

Figure 13-5. Input Qualifier Clock Cycles

Note

For AM263x, SYSCLKOUT = SYSCLK in the diagram above.

13.1.1.4.5 GPIO Interrupt Connectivity

Because this device muxes GPIO signals with other functional signals, the availability of any particular GPIO, and hence the usability of the associated interrupt, changes based on the use case pin muxing. Due to the large number of possible GPIO interrupt sources, routing all interrupt events to each processing element is impractical. Since most applications do not typically require a large number of GPIO interrupts, the interrupt uncertainty is resolved by mapping all GPIO interrupts to a series of event muxes implemented using Interrupt Router (IntRouter) modules. These muxes allow any one of the available GPIO interrupts to be selected and passed on as an event to the various processor interrupt controllers and DMA controllers. Event selection is controlled through associated registers within each IntRouter.

The GPIO bank interrupts already represent a consolidation of the 16 GPIO interrupts associated with each bank and are routed directly to various interrupt controllers rather than through the GPIO IntRouters.

Refer to [Section 10.3, Interrupt Routers](#), for more details on the GPIO Interrupt Routers connectivity.

13.1.1.4.6 GPIO Emulation Halt Operation

The GPIO peripheral is not affected by emulation halts.

13.1.2 Inter-Integrated Circuit (I2C) Interface

This section describes the Inter-Integrated Circuit (I2C) module in the device.

13.1.2.1 I2C Overview.....	900
13.1.2.2 I2C Environment.....	903
13.1.2.3 I2C Integration.....	910
13.1.2.4 I2C Functional Description.....	913
13.1.2.5 I2C Programming Guide.....	917

13.1.2.1 I2C Overview

The I2C module is a serial bus that supports multiple master devices. In multimaster mode, one or more devices can be connected to the same bus and are capable of controlling the bus. Each I2C device on the bus is recognized by a unique address and can operate as either a transmitter or a receiver, depending on the function of the device. In addition to being a transmitter or receiver, a device connected to the I2C bus can also be considered a master or a slave when performing data transfers.

Note

A master device is the device that initiates the data transfer on a bus and generates the clock signal that permits the transfer. During the transmission, any device addressed by the master is considered the slave.

Data is communicated to devices interfacing to the I2C module using the serial data pin (SDA) and the serial clock pin (SCL) as shown in [Figure 13-6](#). These two wires carry information between the device and the other devices connected to the I2C bus. Both SDA and SCL pins on the device are bidirectional. They must be connected to a positive supply voltage through a pull-up resistor. When the bus is free, both pins are high. The driver of these two pins has an open-drain configuration to perform the wired-AND function.

The device has a special mode that can be entered to ignore a NACK generated from non-compliant I2C devices that are incapable of generating an ACK.

The I2C module consists of the following primary blocks:

- A serial Interface: one data pin (SDA) and one clock pin (SCL)
- The device register interface
 - Data registers to temporarily hold received data and transmitted data traveling between the SDA pin and the CPU or the DMA
 - Control and status registers
- A prescaler to divide down the input clock that is driven to the I2C module
- A peripheral bus interface to enable the CPU and DMA to access the I2C module registers
- An arbitrator to handle arbitration between the I2C module (when configured as a master) and another master
- Interrupt generation logic (interrupts can be sent to the CPU)
- A clock synchronizer that synchronizes the I2C input clock (from the system module) and the clock on the SCL pin, and synchronizes data transfers with masters of different clock speeds.
- A noise filter on each of the two serial pins
- DMA event generation logic that synchronizes data reception and data transmission in the I2C module for DMA transmission

In [Figure 13-6](#), the CPU or the DMA writes data for transmission to I2CDXR and reads received data from I2CDRR. When the I2C module is configured as a transmitter, data written to I2CDXR is copied to I2CXSR and shifted out one bit at a time. When the I2C module is configured as a receiver, received data is shifted into I2CRSR and then copied to I2CDRR.

When the I2C function is not needed, the pins may be controlled as general-purpose input/output (GPIO) pins. The I/O structure of each pin includes:

- programmable slew rate control of the outputs
- open drain mode
- programmable pull enable/disable on the input
- programmable pull up/pull down function on the input

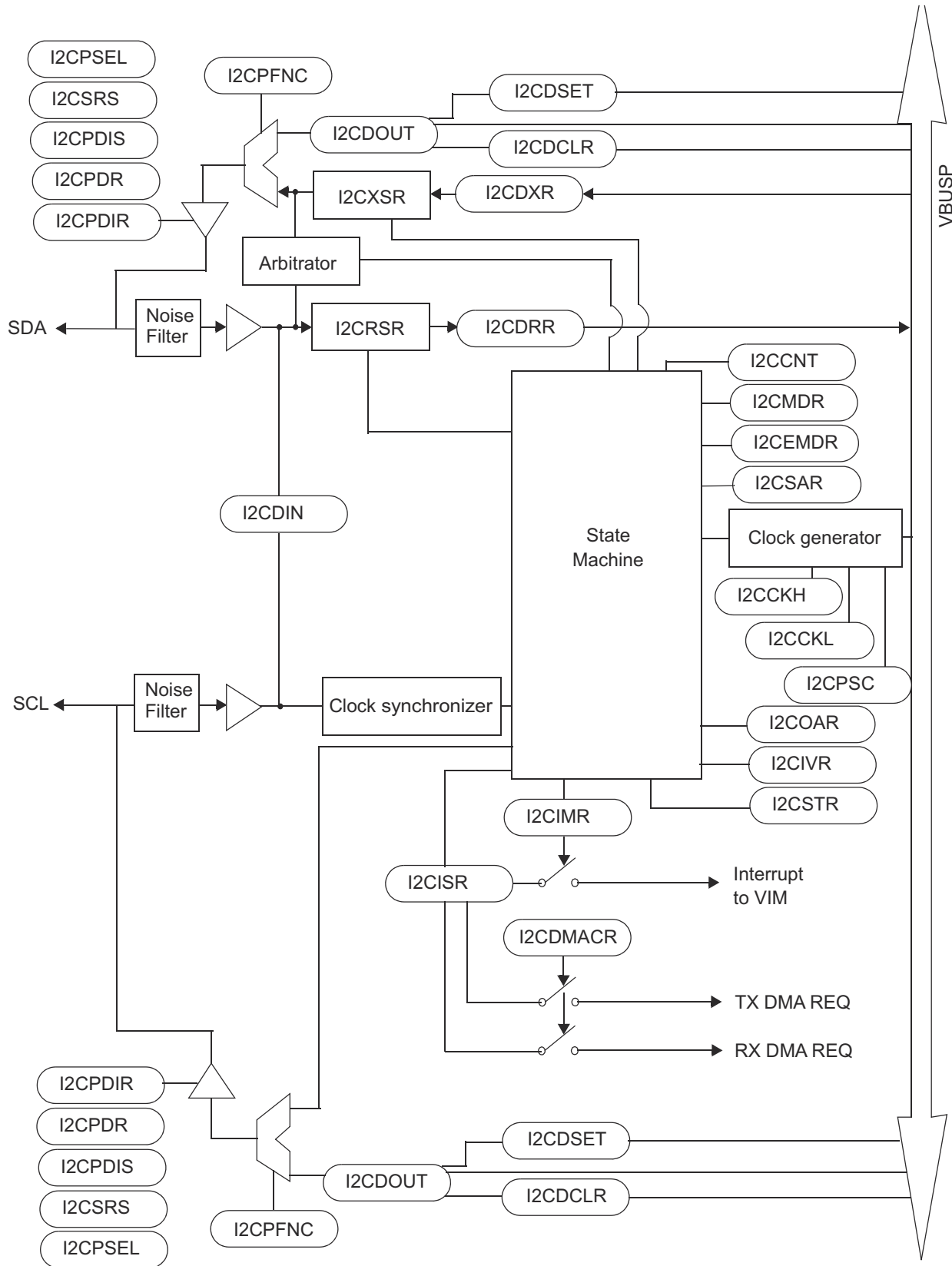

ADVANCE INFORMATION

Figure 13-6. Simple I2C Block Diagram

13.1.2.1.1 I2C Features

Each multimaster I2C module has the following features:

- Compliance to the Philips I²C bus specification, v2.1 (*The I²C Specification*, Philips document number 9398 393 40011)
 - Bit/Byte format transfer
 - 7-bit and 10-bit device addressing modes
 - General call
 - START byte
 - Multi-master transmitter/ slave receiver mode
 - Multi-master receiver/ slave transmitter mode
 - Combined master transmit/receive and receive/transmit mode
 - Transfer rates of 10 kbps up to 400 kbps (Phillips fast-mode rate)
- Free data format
- Two DMA events (transmit and receive)
- DMA event enable/disable capability
- Seven interrupts that can be used by the CPU
- Operates with VBUS frequency from 6.7 MHz up
- Operates with module frequency between 6.7 MHz to 13.3 MHz
- Module enable/disable capability
- The SDA and SCL are optionally configurable as general purpose I/O
- Slew rate control of the outputs
- Open drain control of the outputs
- Programmable pullup/pulldown capability on the inputs
- Supports Ignore NACK mode

13.1.2.1.2 I2C Not Supported Features

- High-speed (HS) mode
- C-bus compatibility mode
- The combined format in 10-bit address mode (the I2C sends the slave address second byte every time it sends the slave address first byte)
- Low power clock enable
- EnDAT support for PRU1 GPIO at 200MHz
- EnDAT use on PRU0 and SD modes of ICSSM

13.1.2.2 I2C Environment

The MCU_I2C[0-1], and I2C[0-3] modules are hereinafter referred to as I2C module.

This section describes the I2C external connections (environment).

13.1.2.2.1 I2C Typical Application

Figure 13-7 shows the multimaster I2C controller and their related connections with I2C-compliant devices.

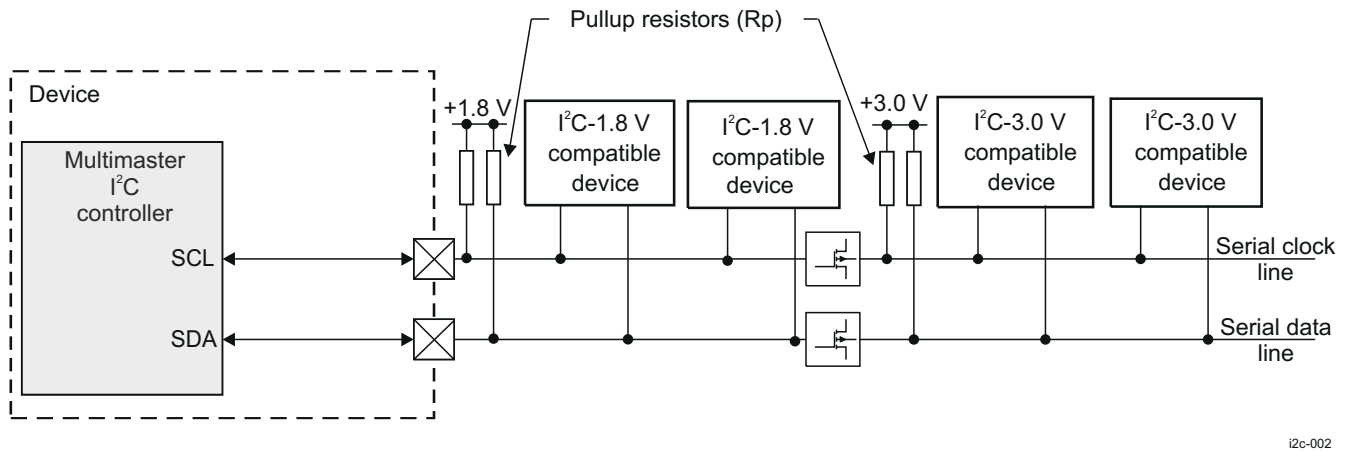

Figure 13-7. I2C and Typical Connections to I2C Devices

i2c-002

Table 13-13 describes the I2C I/O signals.

Table 13-13. I2C I/O Signals

		I2C[0-4]		
SCL	I2C[0]_SCL	I/O	I ² C serial clock line. Open-drain output buffer.	1
SDA	I2C[0]_SDA	I/O	I ² C serial data line. Open-drain output buffer.	1
SCL	I2C[1:4]_SCL	I/O	I ² C serial clock line. Emulated open-drain output buffer.	1
SDA	I2C[1:4]_SDA	I/O	I ² C serial data line. Emulated open-drain output buffer.	1

(1) I = Input; O = Output; I/O = Bidirectional

13.1.2.2.1.2

Note

For more information about device level signals (pull-up/down resistors, buffer type, multiplexing and others), see tables *Pin Attributes* and *Pin Multiplexing* in the device-specific Datasheet.

13.1.2.2.2 I2C Typical Connection Protocol and Data Format

13.1.2.2.2.1 I2C Serial Data Formats

The I2C module operates in byte data format. Each message put on the SDA line is 2 to 8-bits long. The number of messages that can be transmitted or received is unrestricted. The data is transferred with the most significant bit (MSB) first (Figure 13-8). Each message is followed by an acknowledge bit from the I2C if it is in receiver mode. The I2C module does not support little endian systems.

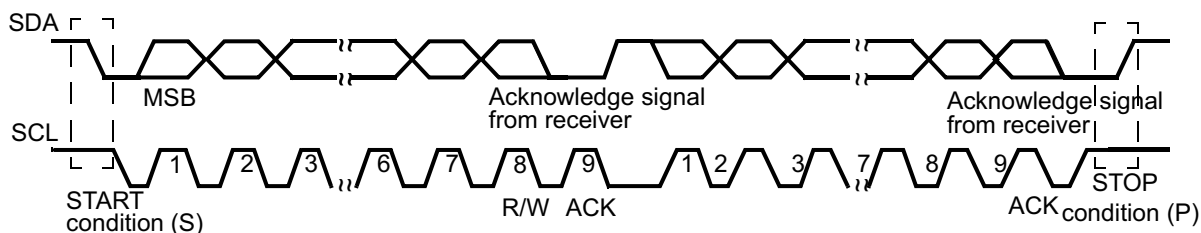
Figure 13-8. I2C Module Data Transfer

The first byte after a START condition (S) always consists of 8 bits that comprise either a 7-bit address plus the R/ \bar{W} bit, or 8 data bits. The eighth bit, R/ \bar{W} , in the first byte determines the direction of the data. When the R/ \bar{W} bit is 0, the master writes (transmits) data to a selected slave device; when the R/ \bar{W} bit is 1, the master reads (receives) data from the slave device. In acknowledge mode, an extra bit dedicated for the acknowledgement (ACK) bit is inserted after each message.

The I2C module supports the following formats:

- 7-bit addressing format ([Section 13.1.2.2.2.4.1](#))
- 10-bit addressing format ([Section 13.1.2.2.2.4.2](#))
- 7-bit/10-bit addressing format with repeated START condition ([Section 13.1.2.2.2.4.3](#))
- Free-data format ([Section 13.1.2.2.2.4.4](#))

13.1.2.2.2.2 I2C Data Validity

The data on the serial data line (SDA) must be stable during the high period of the serial clock line. The high and low states of the data line can change only when the clock signal on the serial clock line (SCL) is low.

Figure 13-9 is an example of data validity requirements.

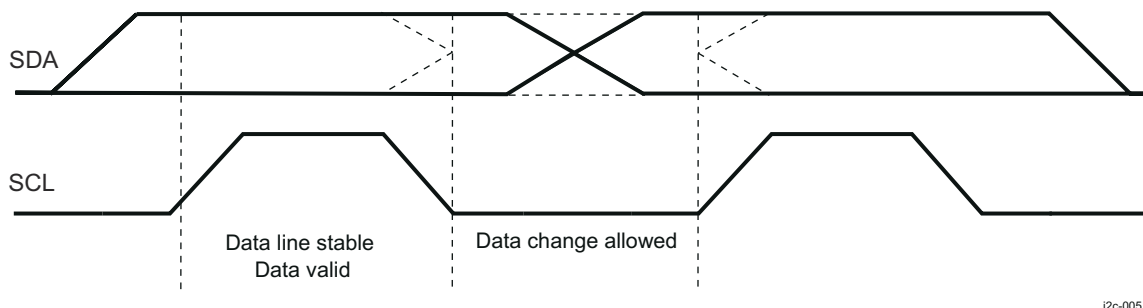
Figure 13-9. I2C Bit Transfer on the I2C Bus

i2c-005

13.1.2.2.2.3 I2C Start and Stop Conditions

START and STOP conditions are generated by a master I2C module.

- The START condition is defined as a high-to-low transition on the SDA line while SCL is high. A master drives this condition to indicate the start of data transfer. The bus is considered to be busy after the START condition, and the bus busy bit (BB) in I2CSR is set to 1.
- The STOP condition is defined as a low-to-high transition on the SDA line while SCL is high. A master drives this condition to indicate the end of data transfer. The bus is considered to be free after the STOP condition, therefore the BB bit in I2CSR is cleared to 0.

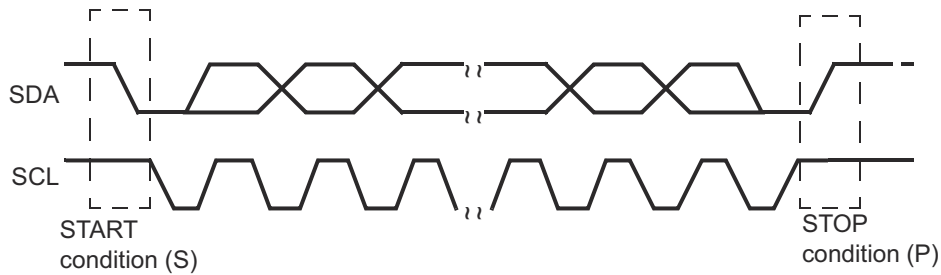

Figure 13-10. I2C Module START and STOP Conditions

For the I2C module to start a data transfer with a START condition, the master mode bit (MST) and the START condition bit (STT) in the I2CMDR must both be set to 1. For the I2C module to end a data transfer with a STOP condition, the STOP condition bit (STP) must be set to 1. When the BB bit is set to 1 and the STT bit is set to 1, a repeated START condition is generated.

13.1.2.2.2.4 I2C Addressing

The I2C module supports two data formats in fast/standard (F/S) mode:

- 7-bit/10-bit addressing format
- 7-bit/10-bit addressing format with repeated start (Sr) condition

13.1.2.2.2.4.1 7-Bit Addressing Format

In the 7-bit addressing format (Figure 13-11), the first byte after the START condition consists of a 7-bit slave address followed by the R/ \bar{W} bit (in the LSB). The R/ \bar{W} bit determines the direction of the data transfer:

- R/ \bar{W} = 0: The master writes (transmits) data to the addressed slave.
- R/ \bar{W} = 1: The master reads (receives) data from the slave.

An extra clock cycle dedicated for acknowledgement (ACK) is inserted after each byte. If the ACK is inserted by the slave after the first byte from the master, it is followed by n bits of data from the transmitter (master or slave, depending on the R/ \bar{W} bit). The device I2C allows n to be a number between 2 to 8, programmable by the bit count (BC) field of I2CMDR. After the data bits have been transferred, the receiver inserts an ACK bit.

To select the 7-bit addressing format, write 0 to the expanded address enable (XA) bit of I2CMDR and make sure the free data format mode is off (FDF = 0 in I2CMDR).

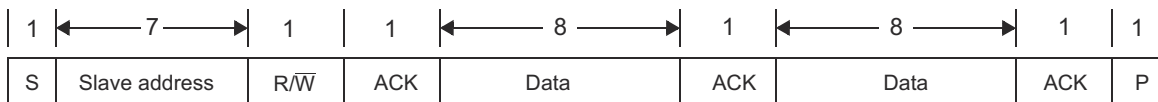

Figure 13-11. I2C Module 7-Bit Addressing Format

13.1.2.2.2.4.2 10-Bit Addressing Format

The 10-bit addressing format is similar to the 7-bit addressing format, but the master sends the slave address in two separate byte transfers. In the 10-bit addressing format (Figure 13-12), the first byte is 11110b, the two MSBs of the 10-bit slave address, and the R/ \bar{W} bit. The ACK bit is inserted after each byte. The second byte is the remaining 8 bits of the 10-bit slave address. The slave must send an acknowledgement after each of the two byte transfers. Once the master has written the second byte to the slave, the master can either write data or use repeated a START condition to change the data direction.

To select the 10-bit addressing format, write 1 to the expanded address enable (XA) bit of I2CMDR and make sure the free data format mode is off (FDF = 0 in I2CMDR).



Figure 13-12. I2C Module 10-bit Addressing Format

13.1.2.2.2.4.3 Using the Repeated START Condition

At the end of each byte, the master can drive another START condition (Figure 13-13). Using this capability, a master can transmit/receive any number of data bytes before generating a STOP condition. The length of a data byte can be from 2 to 8 bits. The repeated START condition can be used with the 7-bit addressing, 10-bit addressing, or the free data formats.

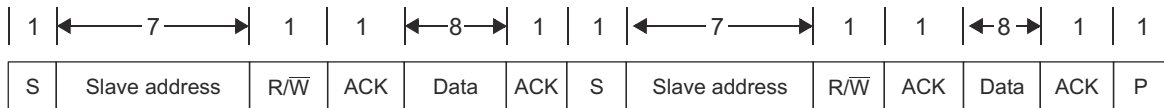

Figure 13-13. I2C Module 7-Bit Addressing Format with Repeated START

13.1.2.2.2.4.4 Free Data Format

In this format (Figure 13-14), the first byte after a START condition is a data byte. The ACK bit is inserted after each byte, followed by another 8 bits of data. No address or data direction bit is sent. Therefore, the transmitter and receiver must both support the free data format. The direction of data transmission (transmit or receive) remains constant throughout the transfer.

To select the free data format, write a 1 to the free data format (FDF) bit of the I2CMDR. The free data format is not supported in the digital loop back mode.

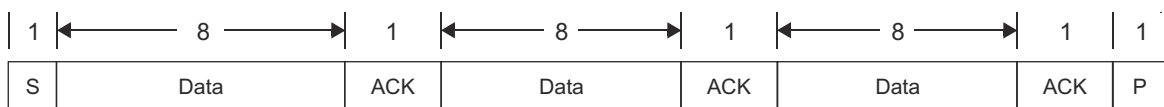

Figure 13-14. I2C Module in Free Data Format

13.1.2.2.2.4.5 Data Transfer Formats in F/S Mode

Figure 13-15 shows the I2C data transfer formats in F/S mode.



(a) 7-bit addressing format

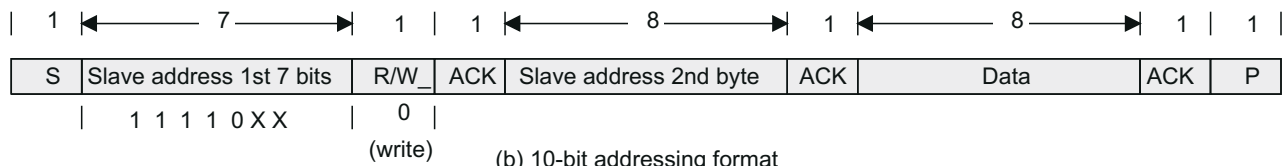

(b) 10-bit addressing format

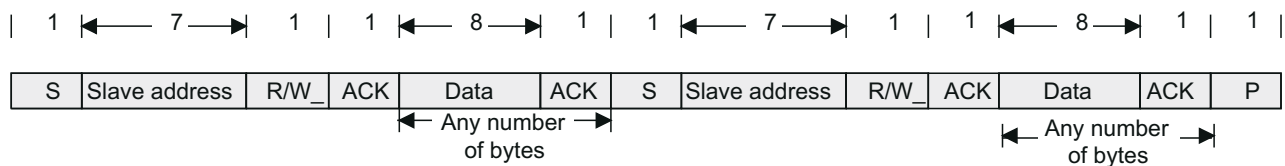

(c) Addressing format with repeated start condition

i2c-007

Figure 13-15. I2C Data Transfer Formats in F/S Mode

The first word after an S condition consists of 8 bits. In acknowledge mode, an extra dedicated acknowledgment bit is inserted after each byte.

ADVANCE INFORMATION

In addressing formats with 7-bit addresses, the first byte is composed of 7 MSB slave address bits and 1 least-significant bit (LSB) R/W_ bit.

The LSB R/W_ bit of the address byte indicates the transmission direction of the data bytes that follow it. If R/W_ is 0, the master writes data to the selected slave; if it is 1, the master reads data from the slave.

In addressing formats with 10-bit addresses, the structure of the first byte is 11110XXY, where XX is the two MSBs of the 10-bit addresses, and Y is the R/W_ bit. If the R/W_ bit is 0, the next byte contains the last 8 bits of the slave address. If the R/W_ bit is 1, the next byte contains data transmitted from the slave to the master.

13.1.2.2.2.5 I2C Master Transmitter

All masters begin in this mode. The I2C module is a master and transmits control information and data to a slave. In this mode, data assembled in any of the addressing formats shown in [Figure 13-11](#), [Figure 13-12](#), or [Figure 13-13](#) is shifted out onto the SDA pin and synchronized with the self-generated clock pulses on the SCL pin. The clock pulses are inhibited and the SCL pin is held low when the intervention of the device is required (XSMT = 0) after a byte has been transmitted.

Note

If the I2C is configured for two simultaneous master transmissions, wait until the MST and BB have been reset before performing the second master transmission.

Failure to wait for the MST and BB to reset will prevent the start condition on the second transfer from being issued and the bus BB will not be set. Typically the end of the first transfer is handled by polling BB. However, the MST bit is not reset at the same instant as the BB bit. As a result, when the second master transmission is initiated before the resetting of the MST, the MST bit for the second transfer is reset. This prevents the I2C from recognizing itself as the master, thus failing to occupy the bus.

13.1.2.2.2.6 I2C Master Receiver

In this mode, the I2C module is a master and receives data from a slave. This mode can only be entered from the master transmitter mode (the I2C module must first transmit a command to the slave). In any of the addressing formats shown in [Section 13.1.2.2.2.4.1](#), [Section 13.1.2.2.2.4.2](#), or [Section 13.1.2.2.2.4.3](#), the master receiver mode is entered after the slave address byte and the R/ \bar{W} bit have been transmitted (if the R/ \bar{W} bit is 1). Serial data bits received on the SDA pin are shifted in with the self-generated clock pulses on the SCL pin. The clock pulses are inhibited and the SCL is held low when the intervention of the device is required (RSFULL = 1) after a byte has been received. At the end of the transfer, the master-receiver signals the end of data to the slave-transmitter by not generating an acknowledge on the last byte that was clocked out of the slave. The slave-transmitter then releases the data line allowing the master-receiver to generate a STOP condition or a repeated START condition.

In many applications, the size of the message is in the initial bytes of the message itself. Since the size of the message is not known to the master before the transmission/reception starts, the master must use the repeat mode in order to force the stop condition when the reception is completed. The repeat mode is enabled by setting the RM bit to 1. Due to the double buffer implementation on the receive side, the master must generate the stop condition (STP = 1) after reading the (message size - 1)th data.

13.1.2.2.2.7 I2C Slave Transmitter

In this mode, the I2C module is a slave and transmits data to a master. This mode can only be entered from the slave receiver mode (The I2C module must first receive a command from the master). In any of the addressing formats shown in [Section 13.1.2.2.2.4.1](#), [Section 13.1.2.2.2.4.2](#), or [Section 13.1.2.2.2.4.3](#), the slave transmitter mode is entered if the slave address byte is the same as its own address and the R/ \bar{W} bit has been transmitted (if the R/ \bar{W} bit is set to 1). The slave transmitter shifts the serial data out on the SDA pin with the clock pulses that are generated by the master device. The slave device does not generate the clock, but it can hold the SCL pin low when intervention of the device is required (XSMT = 0) after a byte has been transmitted.

13.1.2.2.2.8 I2C Slave Receiver

In this mode, the I2C module is a slave and receives data from a master. All slaves begin in this mode. Serial data bits received on the SDA pin are shifted in with the clock pulses that are generated by the master device. The slave device does not generate the clock, but it can hold the SCL pin low while intervention of the device is required (RSFULL = 1) after a byte has been received.

13.1.2.2.2.9 I2C Bus Arbitration

If two or more master transmitters simultaneously start a transmission on the same bus, an arbitration procedure is invoked. [Figure 13-16](#) illustrates the arbitration procedure between two devices. The arbitration procedure uses the data presented on the SDA bus by the competing transmitters. The first master transmitter that generates a high is overruled by the other master that generates a low. The arbitration procedure gives priority to the device that transmits the serial data stream with the lowest binary value. The master transmitter that loses the arbitration switches to the slave receiver mode, sets the arbitration lost (AL) flag, and generates the arbitration-lost interrupt. The data transmitted by the other master module is salvaged, and the I2C continues to receive data from the master module. Should two or more devices send identical first bytes, arbitration continues on the subsequent bytes.

If, during a serial transfer, the arbitration procedure is still in progress when a repeated START condition or STOP condition is transmitted to I2C bus, the master transmitters involved must send the repeated START condition or STOP condition at the same position in the format frame. In other words, arbitration is not allowed between:

- A repeated START condition and a data bit
- A STOP condition and a data bit
- A repeated START condition and a STOP condition

Slaves are not involved in the arbitration procedure.

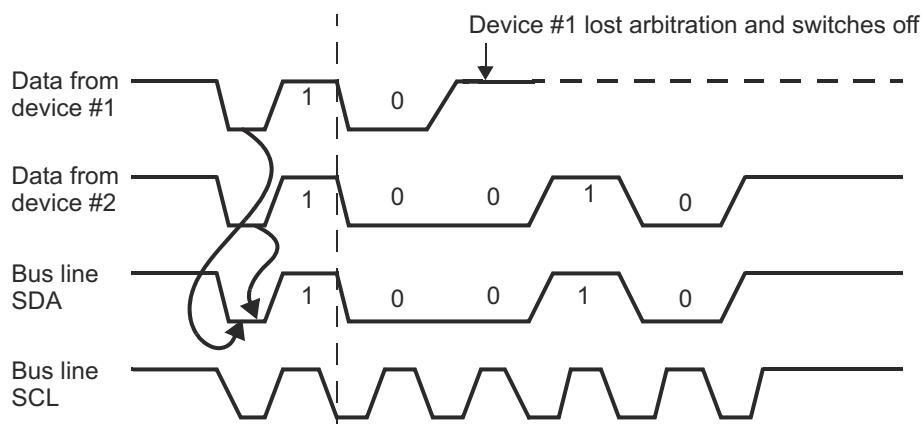

Figure 13-16. Arbitration Procedure Between Two Master Transmitters

13.1.2.2.2.10 I2C Clock Generation and Synchronization

Under normal conditions only one master device generates the clock signal; the SCL. During the arbitration procedure, however, there are two or more master devices and the clock must be synchronized so that the data output can be compared. [Figure 13-17](#) illustrates clock synchronization. The wired-AND property of the SCL line means that a device that first generates a low period on the SCL overrules the other devices. At this high-to-low transition, the clock generators of the other devices are forced to start their own low period. The SCL line is held low by the device with the longest low period. The other devices that finish their low periods must wait for the SCL line to be released before starting their high periods. A synchronized signal on the SCL is obtained where the slowest device determines the length of the low period and the fastest device determines the length of the high period.

If a device pulls down the clock line for a longer time, the result is that all clock generators must enter the wait state. In this way, a slave slows down a fast master and the slow device creates enough time to store a received byte or to prepare a byte to be transmitted.

Note

I2C Protocol Fault

The following conditions violate the clock spec as defined in the Philips I²C bus specification, v2.1 (*The I²C Specification*, Philips document number 9398 393 40011), and will result in an I2C protocol fault: I2CCLKH = 2 I2CCLKL = 2I2CPSC = 2. This will cause the SDA data transition to occur while the SCL is high.

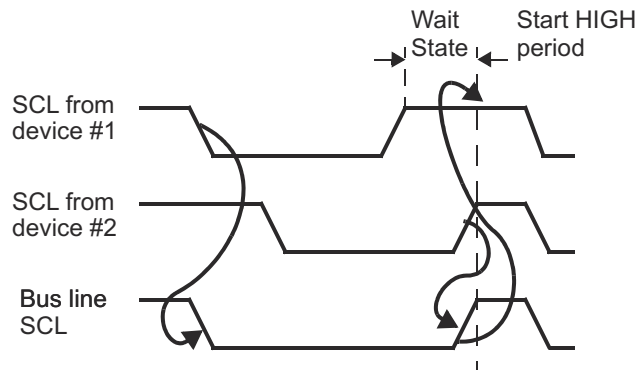

Figure 13-17. Synchronization of Two I2C Clock Generators During Arbitration

13.1.2.3 I2C Integration

There are 4x I2C module integrated in the device. The diagram below provides a visual representation of the device integration details.

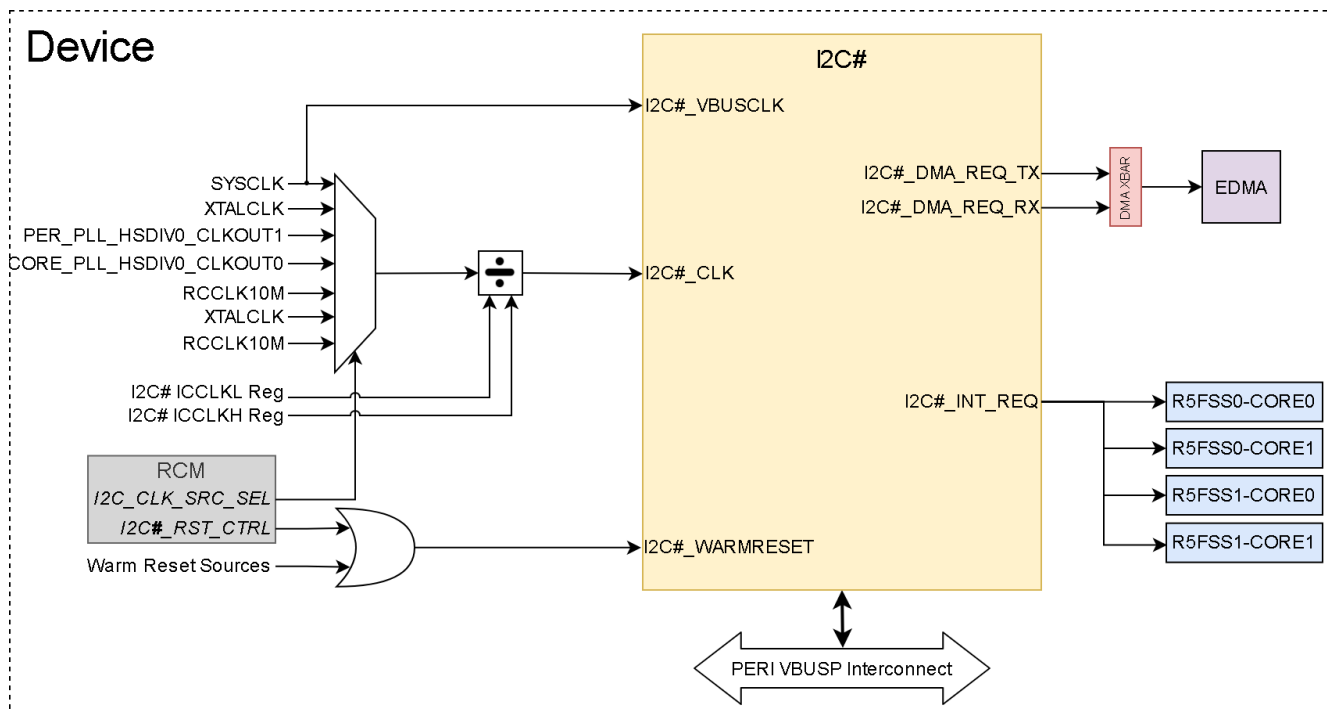

Figure 13-18. I2C Integration

The tables below summarize the device integration details of I2C# (where # = 0, 1, 2, 3).

Table 13-14. I2C Device Integration

This table describes the module device integration details.

Module Instance	Device Allocation	SoC Interconnect
I2C0	✓	PERI VBUSP Interconnect
I2C1	✓	PERI VBUSP Interconnect
I2C2	✓	PERI VBUSP Interconnect
I2C3	✓	PERI VBUSP Interconnect

Table 13-15. I2C Clocks

This table describes the module clocking signals.

Module Instance	Module Clock Input	Source Clock Signal	Source	Default Freq	Description
I2C[0:3]	I2C[0:3]_ICLK (VBUSP_CLK)	SYS_CLK	PLL_CORE_CLK: HSDIV0_CLKOUT0	200 MHz	I2C[0:3] VBUS Clock
		I2C[0:3]_FCLK (I2C_CLK)	XTALCLK	External XTAL	25 MHz
	EXT_REFCLK	External Reference Clock (EXT_REFCLK)	100 MHz		
	SYS_CLK	PLL_CORE_CLK: HSDIV0_CLKOUT0	200 MHz		
	DPLL_PER_HSDIV0_CLK OUT1	PLL_PER_CLK: HSDIV0_CLKOUT1	192 MHz		
	DPLL_CORE_HSDIV0_CL KOUT0	PLL_CORE_CLK: HSDIV0_CLKOUT0	500 MHz		
	RCCLK10M	Internal 10 MHz RC Oscillator (RCCLK10M)	10 MHz		
	XTALCLK	External XTAL	25 MHz		
RCCLK10M	Internal 10 MHz RC Oscillator (RCCLK10M)	10 MHz			

Table 13-16. I2C Resets

This table describes the module reset signals.

Module Instance	Module Reset Input	Source Reset Signal	Source	Description
I2C0	I2C0_RST(VBUSP_RSTn)	Warm Reset (SYS_NPRST)	RCM + Warm Reset Sources	I2C0 Asynchronous Reset
I2C1	I2C1_RST	Warm Reset (SYS_NPRST)	RCM + Warm Reset Sources	I2C1 Asynchronous Reset
I2C2	I2C2_RST	Warm Reset (SYS_NPRST)	RCM + Warm Reset Sources	I2C2 Asynchronous Reset
I2C3	I2C3_RST	Warm Reset (SYS_NPRST)	RCM + Warm Reset Sources	I2C3 Asynchronous Reset

Table 13-17. I2C Interrupt Requests

This table describes the module interrupt requests.

Module Instance	Module Interrupt Signal	Destination Interrupt Input	Destination	Type	Description
I2C0	i2c0_int_req	i2c0_int_req	ALL R5FSS Cores ICSSM Core	Pulse	I2C0 Status Event Interrupt
I2C1	i2c1_int_req	i2c1_int_req	ALL R5FSS Cores ICSSM Core	Pulse	I2C1 Status Event Interrupt
I2C2	i2c2_int_req	i2c2_int_req	ALL R5FSS Cores ICSSM Core	Pulse	I2C2 Status Event Interrupt
I2C3	i2c3_int_req	i2c3_int_req	ALL R5FSS Cores ICSSM Core	Pulse	I2C3 Status Event Interrupt

Table 13-18. I2C DMA Requests

This table describes the module DMA requests.

Module Instance	Module DMA Event	Destination DMA Event Input	Destination	Type	Description
I2C0	I2C0_TX	i2c0_dma_req_tx	EDMA Crossbar (EDMA_XBAR)	Pulse	I2C0 DMA Transmit Request
	I2C0_RX	i2c0_dma_req_rx			I2C0 DMA Receive Request
I2C1	I2C1_TX	i2c1_dma_req_tx	EDMA Crossbar (EDMA_XBAR)	Pulse	I2C1 DMA Transmit Request
	I2C1_RX	i2c1_dma_req_rx			I2C1 DMA Receive Request
I2C2	I2C2_TX	i2c2_dma_req_tx	EDMA Crossbar (EDMA_XBAR)	Pulse	I2C2 DMA Transmit Request
	I2C2_RX	i2c2_dma_req_rx			I2C2 DMA Receive Request
I2C3	I2C3_TX	i2c3_dma_req_tx	EDMA Crossbar (EDMA_XBAR)	Pulse	I2C3 DMA Transmit Request
	I2C3_RX	i2c3_dma_req_rx			I2C3 DMA Receive Request

Note

For more information on the interconnects, see the *System Interconnect* chapter.

For more information on power, reset, and clock management, see the corresponding sections within the *Device Configuration* chapter.

For more information on the device interrupt controllers, see the *Interrupt Controllers* chapter.

13.1.2.4 I2C Functional Description

13.1.2.4.1 I2C Block Diagram

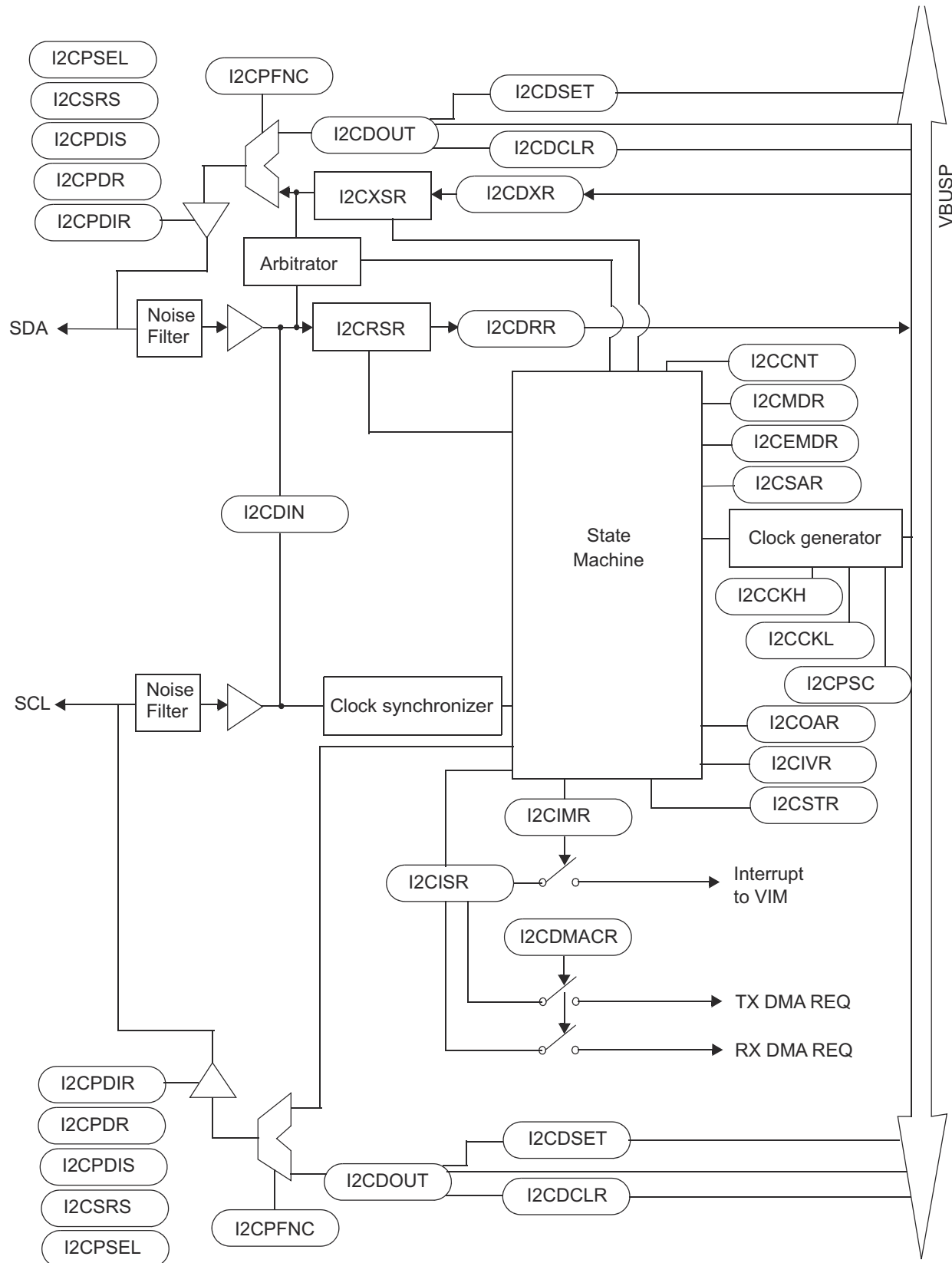

ADVANCE INFORMATION

Figure 13-19. I2C Block Diagram

13.1.2.4.2 I2C Clocks

13.1.2.4.2.1 I2C Clocking

Figure 13-20 shows the I²C clock generation of the I2C controllers.

Figure 13-20. I2C Clock Generation

The I2C module is operated by the module clock. This clock is generated by way of the I2C prescaler block. The prescaler block consists of a 8-bit register, I2CPSC, used for dividing down the device peripheral clock (VBUS_CLK) to obtain a module clock between 6.7 MHz and 13.3 MHz.

As shown in , the I2C module uses the input clock generated from the device clock generator to generate the module clock and master clock. The I2C input clock is the device peripheral clock (VBUS_CLK). The clock is then divided twice more inside the I2C module to produce the module clock and the master clock.

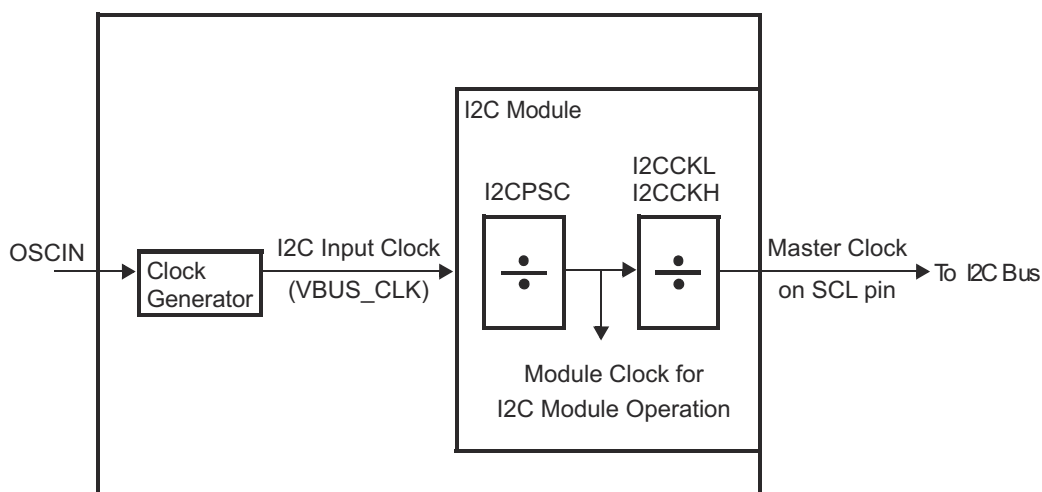

Figure 13-21. Clocking Diagram for the I2C Module

The module clock determines the frequency at which the I2C module operates. A programmable prescaler in the I2C module divides down the input clock to produce the module clock. To specify the divide-down value, initialize the I2CPSC field of the prescaler register, I2CPSC. The resulting frequency is:

$$ModuleClockFrequency = \frac{I2CInputClockFrequency}{(I2CPSC + 1)} \quad (22)$$

The module clock frequency must be between 6.7MHz and 13.3MHz. The prescaler can only be initialized while the I2C module is in the reset state (IRS = 0 in I2CMDR). The prescaled frequency takes effect only when IRS is changed to 1. Changing the I2CPSC value while IRS = 1 has no effect.

The master clock appears on the SCL pin when the I2C module is configured to be a master on the I2C bus. This clock controls the timing of the communication between the I2C module and a slave. As shown in , a second clock divider in the I2C module divides down the module clock to produce the master clock. The clock divider uses the I2CCKL to divide down the low portion of the module clock signal and uses the I2CCKH to divide down the high portion of the module clock signal.

The resulting frequency is:

$$MasterClockFrequency = \frac{ModuleClockFrequency}{(I2CCKL + d) + (I2CCKH + d)} \quad (23)$$

$$MasterClockFrequency = \frac{I2CInputClockFrequency}{(I2CPSC + 1)((I2CCKL + d) + (I2CCKH + d))} \quad (24)$$

where d depends on the value of I2CPSC:

I2CPSC	d
0	7
1	6
Greater than 1	5

Note

The master clock frequency defined above does not include rise/fall time and latency of the synchronizer inside the module. The actual transfer rate will be slower than the value calculated from the formula above. Also, due to the nature of SCL synchronization, the SCL clock period could change if SCL synchronization is taking place.

Table 13-19. I2C Register Values for Maximum I2C Bit Rates in I2C F/S, I2C HS Modes⁽¹⁾

	I ² C Mode for			Description
	Standard Mode	Fast Mode	High-Speed Mode ⁽²⁾	
SYS_CLK frequency (MHz)	96			
OCP_CLK frequency (MHz)	133			
I2C_PSC[7-0] PSC	23	9	1	Prescaler value for F/S and HS modes
INTERNAL_CLK frequency (MHz)	4	9.6	96	
I2C_SCLL[7-0] SCLL	13	7	115	Value for F/S mode and first phase of HS mode
I2C_SCLH[7-0] SCLH	15	5	113	Value for F/S mode and first phase of HS mode
Maximum bit rate (Mbps)	0.1	0.4	0.4	F/S mode and first phase in HS mode maximum bit rate
Maximum filter period (ns)	250	104.2	10	
I2C_SCLL[15-8] HSSCLL			12	Values for second phase of HS mode
I2C_SCLH[15-8] HSSCLH			5	Values for second phase of HS mode
HS mode maximum bit rate (Mbps)			3.31	HS mode maximum bit rate
Maximum filter period (ns)			10	

(1) Programmable fields are in bold.

(2) HS mode is not supported on this family of devices.

Note

This table presents informative values only for the configuration parameters and the I²C bus performance obtained according to these values. The delays added by the analog pads are not considered in these figures.

Note

For MCU_I2C[0-1]

For I2C[0-3]

$I2Ci_INTERNAL_CLK \text{ freq} = I2Ci_SYS_CLK / (PSC + 1)$

$F/S \text{ filter period} = 1 / I2Ci_INTERNAL_CLK$

$HS \text{ filter period} = 1 / I2Ci_SYS_CLK \text{ freq}$

$HS \text{ bit rate} = I2Ci_SYS_CLK \text{ freq} / (HSSCLL + 7 + HSSCLH + 5)$

$FS \text{ bit rate} = I2Ci_INTERNAL_CLK / (SCLL + 7 + SCLH + 5)$

13.1.2.4.3 I2C Software Reset

The I2C module can be reset in the following two ways:

- Through the global peripheral reset. A device reset causes a global peripheral reset.
- By clearing the \overline{IRS} bit in the I2C mode register (I2CMDR). When the global peripheral reset is removed, the \overline{IRS} bit is cleared to 0, keeping the I2C module in the reset state.

13.1.2.4.4 I2C Interrupt Requests

The I2C module generates seven types of interrupts. These seven interrupts are accompanied with seven interrupt mask bits in the interrupt mask register (I2CIMR) and with seven interrupt flag bits in the status register (I2CSR).

The I2C module generates the interrupt requests described below. All requests are multiplexed through an arbiter into a single I2C interrupt request to the CPU. Each interrupt request has a flag bit and an enable bit. Interrupts must be enabled prior to the occurrence of the expected interrupt condition. When one of the specified events occurs, the flag bit is set. If the corresponding enable bit is 0, the interrupt request is blocked. If the enable bit is 1, the interrupt request is forwarded to the CPU as an I2C interrupt request. As an alternative, the CPU can poll all of the bits shown in [Table 13-20](#).

Table 13-20. Interrupt Requests Generated by I2C Module

Flag	Name	Generated
AL	Arbitration-lost interrupt	Generated when the I2C module has lost an arbitration contest with another master-transmitter
NACK	No-acknowledge interrupt	Generated when the master I2C does not receive an acknowledge from the receiver
ARDY	Register-access-ready interrupt	Generated when the previously programmed address, data and command have been performed and the status bits have been updated. The interrupt is used to notify the device that the I2C registers are ready to be accessed.
RXRDY	Receive-data-ready interrupt	Generated when the received data in the receive-shift register (I2CSR) has been copied into the data receive register (I2CDRR). The RXRDY bit can also be polled by the device to determine when to read the received data in the I2CDRR.
TXRDY	Transmit-data-ready interrupt	Generated when the transmitted data has been copied from the data transmit register (I2CDXR) into the transmit-shift register (I2CXSR). The TXRDY bit can also be polled by the device to determine when to write the next data into I2CDXR.
SCD	Stop-condition-detect interrupt	Generated when a STOP condition has been detected.
AAS	Address-as-slave interrupt	Generated when the I2C has recognized its own slave address or an address of all zeroes.

13.1.2.4.5 I2C Noise Filter

The noise filter is used to suppress any noises that are 50ns or less. It is designed to suppress noise with one module clock, assuming the lower and upper limits of the module clock are 6.7MHz and 13.3MHz, respectively.

13.1.2.5 I2C Programming Guide

13.1.2.5.1 I2C Low-Level Programming Models

13.1.2.5.1.1 I2C Programming Model

This section describes the programming model of the multimaster I2C controllers configured in I²C mode.

13.1.2.5.1.1.1 Main Program

13.1.2.5.1.1.1.1 Configure the Module Before Enabling the I2C Controller

Before enabling the I2C controller, perform the following steps:

1. Enable the functional and interface clocks.
2. Program the prescaler to obtain an approximately 12-MHz internal sampling clock by programming the corresponding value in the I2C_PSC[7-0] PSC bit field. This value depends on the frequency of the functional clock (SYS_CLK).
3. Program the I2C_SCLL[7-0] SCLL and I2C_SCLH[7-0] SCLH bit fields to obtain a bit rate of 100 kbps or 400 kbps. These values depend on the internal sampling clock frequency (see [Section 13.1.2.4.2.1](#)).
4. (Optional) Program the I2C_SCLL[15-8] HSSCLL and I2C_SCLH[15-8] HSSCLH bit fields to obtain a bit rate of 400 kbps or 3.4 Mbps (for the second phase of HS mode). These values depend on the internal sampling clock frequency (see [Section 13.1.2.4.2.1](#)).
5. Configure the Own Address of the I2C controller by storing it in the I2C_OA register. Up to four Own Addresses can be programmed in the I2C_OA and I2C_OAx registers (where x = 1, 2, 3) for each I2C controller.

Note

For a 10-bit address, set the corresponding expand Own Address bit in the I2C_CON register.

6. Set the TX threshold (in transmitter mode) and the RX threshold (in receiver mode) by setting the I2C_BUF[5-0] TXTRSH bit field to (TX threshold – 1) and the I2C_BUF[13-8] RXTRSH bit field to (RX threshold – 1), where the TX and RX thresholds are greater than or equal to 1.
7. Take the I2C controller out of reset by setting the I2C_CON[15] I2C_EN bit to 1.

13.1.2.5.1.1.1.2 Initialize the I2C Controller

To initialize the I2C controller, perform the following steps:

1. Configure the I2C_CON register:
 - For master or slave mode, set the I2C_CON[10] MST bit (0: slave; 1: master).
 - For transmitter or receiver mode, set the I2C_CON[9] TRX bit (0: receiver; 1: transmitter).
2. If using an interrupt to transmit and receive data, set the corresponding bit in the I2C_IRQENABLE_SET register to 1 (the I2C_IRQENABLE_SET [4] XRDY_IE bit for the transmit interrupt, the I2C_IRQENABLE_SET [3] RRDY bit for the receive interrupt).

13.1.2.5.1.1.1.3 Configure Slave Address and the Data Control Register

In master mode, configure the slave address register by programming the I2C_SA[9-0] SA bit field and the number of data bytes (I²C data payload) associated with the transfer by programming the I2C_CNT[15-0] DCOUNT bit field.

Note

For a 10-bit address, set the I2C_CON[8] XSA bit to 1.

13.1.2.5.1.1.1.4 Initiate a Transfer

Poll the I2C_IRQSTATUS_RAW [12] BB bit. If it is cleared to 0 (bus not busy), configure the I2C_CON[0] STT and I2C_CON[1] STP bits. To initiate a transfer, the I2C_CON[0] STT bit must be set to 1, and it is not mandatory to set the I2C_CON[1] STP bit to 1.

13.1.2.5.1.1.1.5 Receive Data

Poll the I2C_IRQSTATUS_RAW [3] RRDY bit, or use the RRDY interrupt (the I2C_IRQENABLE_SET [3] RRDY_IE bit must be set to 1) to read the receive data in the I2C_DATA register.

If the transfer length does not equal the RX FIFO threshold (the I2C_BUF[13-8] RTRSH bit field + 1), use the draining feature (enable the RDR interrupt by setting the I2C_IRQENABLE_SET [13] RDR_IE bit to 1).

Note

In receive mode only, the I2C_IRQSTATUS_RAW [11] ROVR (receive overrun) bit indicates whether the receiver has experienced overrun. An overrun condition occurs when the shift register and the RX FIFO are full. An overrun condition does not result in data loss; the I2C controller simply holds SCL to low to prevent other bytes from being received.

The I2C_IRQSTATUS_RAW[7] AERR bit is set to 1 when a read access is performed in the I2C_DATA register while the RX FIFO is empty. The corresponding interrupt can be enabled by setting the I2C_IRQENABLE_SET [7] AERR_IE bit to 1.

13.1.2.5.1.1.1.6 Transmit Data

Poll the I2C_IRQSTATUS_RAW [4] XRDY bit, or use the XRDY interrupt (the I2C_IRQENABLE_SET [4] XRDY_IE bit must be set to 1) to write data to the I2C_DATA register.

If the transfer length does not equal the TX FIFO threshold (the I2C_BUF[5-0] TXTRSH bit field + 1), use the draining feature (enable the XDR interrupt by setting the I2C_IRQENABLE_SET [14] XDR_IE bit to 1).

Note

In transmit mode only, the I2C_IRQSTATUS_RAW [10] XUDF bit indicates whether the transmitter has experienced underflow.

In master transmit mode, underflow occurs when the shift register and the TX FIFO are empty and there are still some bytes to transmit (the value of the I2C_CNT[15-0] DCOUNT bit field is not 0).

In slave transmit mode, underflow occurs when the shift register and the TX FIFO are empty and the external I²C master device still requests data bytes to be read.

The I2C_IRQSTATUS_RAW [7] AERR bit is set to 1 when a write access is performed in the I2C_DATA register while the TX FIFO is full. The corresponding interrupt can be enabled by setting the I2C_IRQENABLE_SET [7] AERR_IE bit to 1.

13.1.2.5.1.1.2 Interrupt Subroutine Sequence

1. Test for arbitration lost (the I2C_IRQSTATUS_RAW [0] AL bit) and resolve accordingly.
2. Test for no acknowledgment (the I2C_IRQSTATUS_RAW [1] NACK bit) and resolve accordingly.
3. Test for register access ready (the I2C_IRQSTATUS_RAW [2] ARDY bit) and resolve accordingly.
4. Test for receive data ready (the I2C_IRQSTATUS_RAW [3] RRDY bit) and resolve accordingly.
5. Test for transmit data ready (the I2C_IRQSTATUS_RAW [4] XRDY bit) and resolve accordingly.
6. Test for general call (the I2C_IRQSTATUS_RAW [5] GC bit) and resolve accordingly.
7. Test for start (S) condition (the I2C_IRQSTATUS_RAW [6] STC bit) and resolve accordingly. For this test, the functional clock must be inactive.
8. Test for access error (the I2C_IRQSTATUS_RAW [7] AERR bit) and resolve accordingly.
9. Test for bus free (the I2C_IRQSTATUS_RAW [8] BF bit) and resolve accordingly.

13.1.2.5.1.1.3 Programming Flow-Diagrams

Figure 13-22 through Figure 13-28 are procedure flow charts for programming the F/S and HS I²C modes.

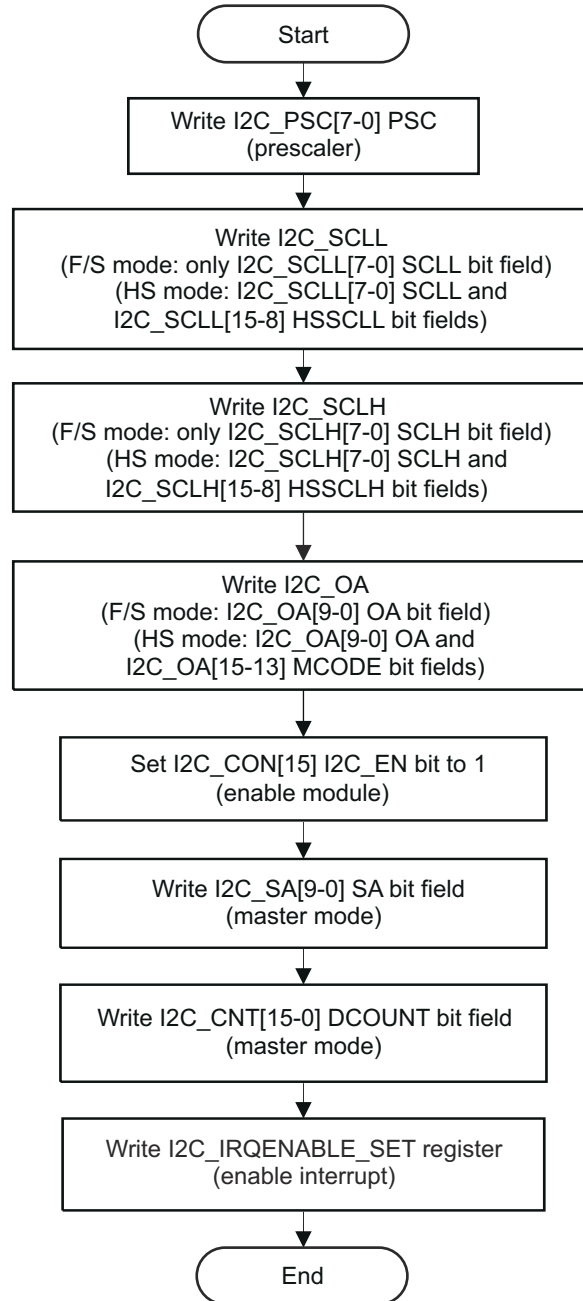

i2c-018

Figure 13-22. I2C Setup Procedure

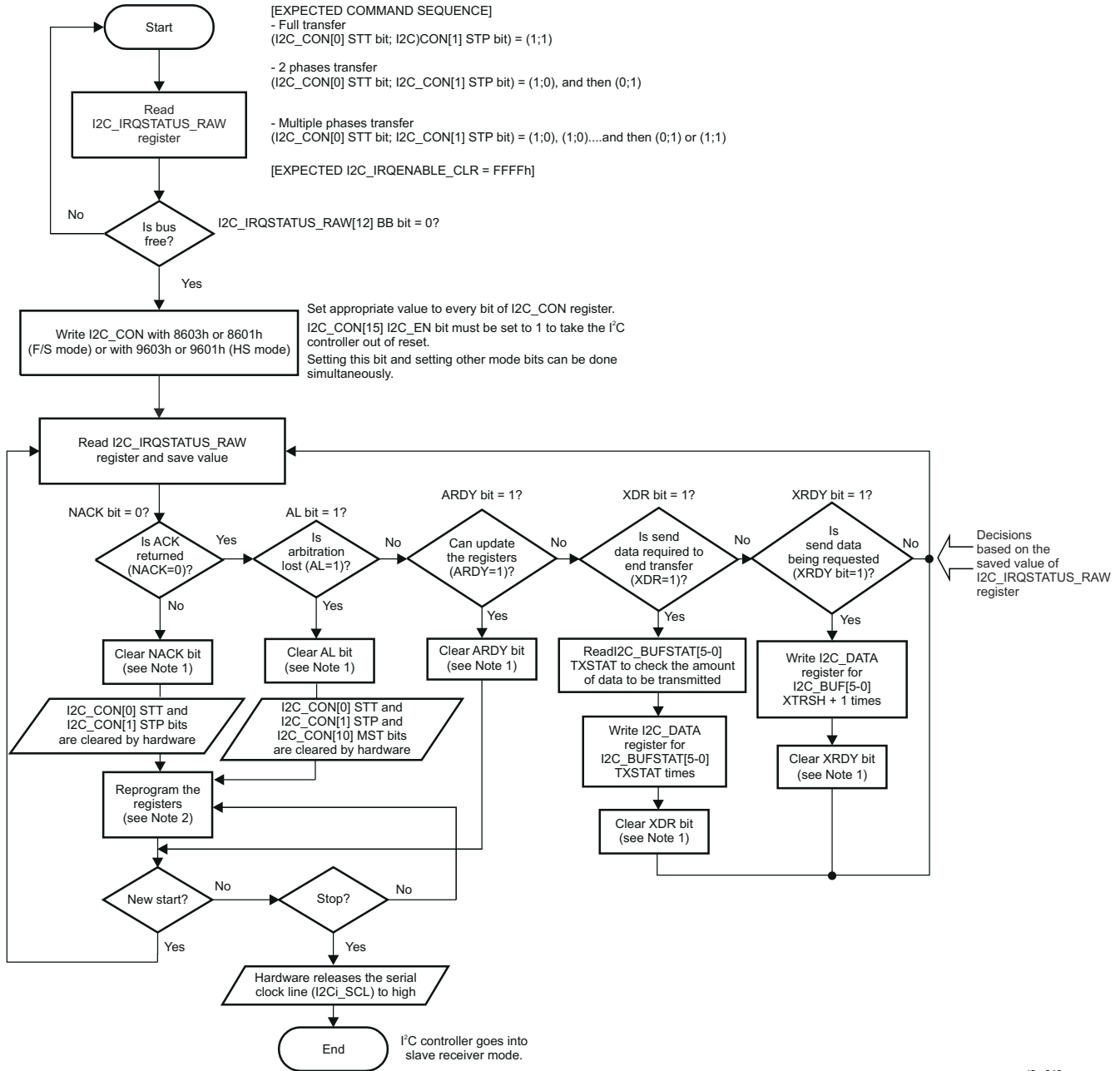

I2c-019

- A. The NACK, AL, ARDY, XDR, and XRDY bits are cleared by writing 1 to each corresponding bit in the I2C_IRQSTATUS register.
- B. Reprogram the registers means: I2C_CON[11] STB and/or I2C_CON[10] MST bit and/or I2C_SA[9-0] SA register and/or I2C_CNT[15-0] DCOUNT register and/or I2C_CON[0] STT bit and/or I2C_CON[1] STP bit.

Figure 13-23. I2C Master Transmitter Mode, Polling Method, in F/S and HS Modes

Note

The FIFO clearing can be made when the module is configured as transmitter, the receiver send a NACK in the middle of the transfer, and there is still data in the FIFO.

Note

In HS mode, the Sr condition and clock frequency switching are automatically generated by the multimaster I2C controller.

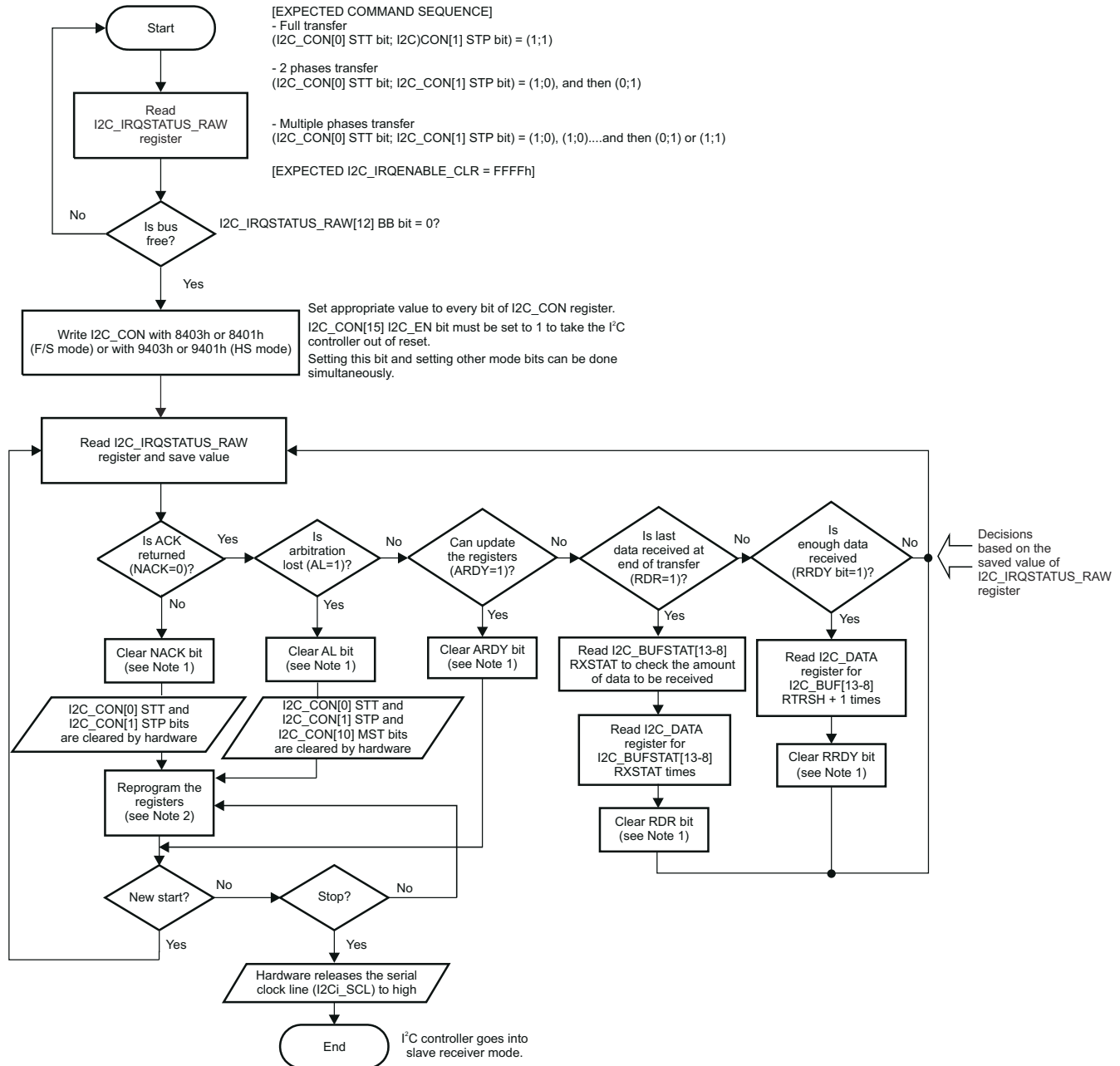

ADVANCE INFORMATION

- A. The NACK, AL, ARDY, RDR, and RRDY bits are cleared by writing 1 to each corresponding bit in the I2C_IRQSTATUS register.
- B. Reprogram registers means: I2C_CON[11] STB and/or I2C_CON[10] MST bit and/or I2C_SA[9-0] SA register and/or I2C_CNT[15-0] DCOUNT register and/or I2C_CON[0] STT bit and/or I2C_CON[1] STP bit.

Figure 13-24. I2C Master Receiver Mode, Polling Method, in F/S and HS Modes

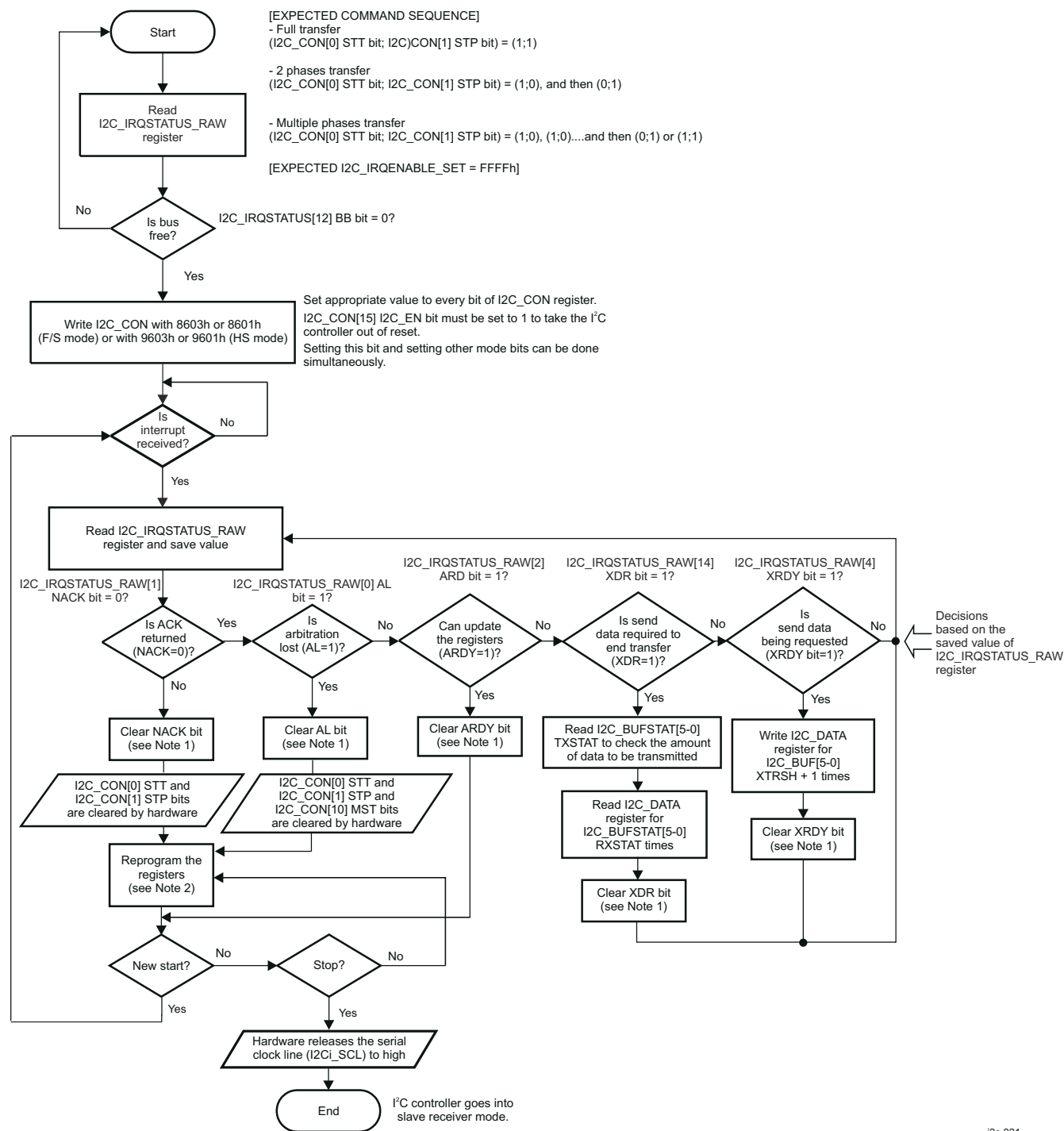

I2C-021

- A. The NACK, AL, ARDY, XDR, and XRDY bits are cleared by writing 1 to each corresponding bit in the I2C_IRQSTATUS register.
- B. Reprogram registers means: I2C_CON[11] STB and/or I2C_CON[10] MST bit and/or I2C_SA[9-0] SA register and/or I2C_CNT[15-0] DCOUNT register and/or I2C_CON[0] STT bit and/or I2C_CON[1] STP bit.

Figure 13-25. I2C Master Transmitter Mode, Interrupt Method, in F/S and HS Modes

Note

The FIFO clearing can be made when the module is configured as transmitter, the receiver send a NACK in the middle of the transfer, and there is still data in the FIFO.

Note

In HS mode, the Sr condition and clock frequency switching are automatically generated by the multimaster I2C controller.

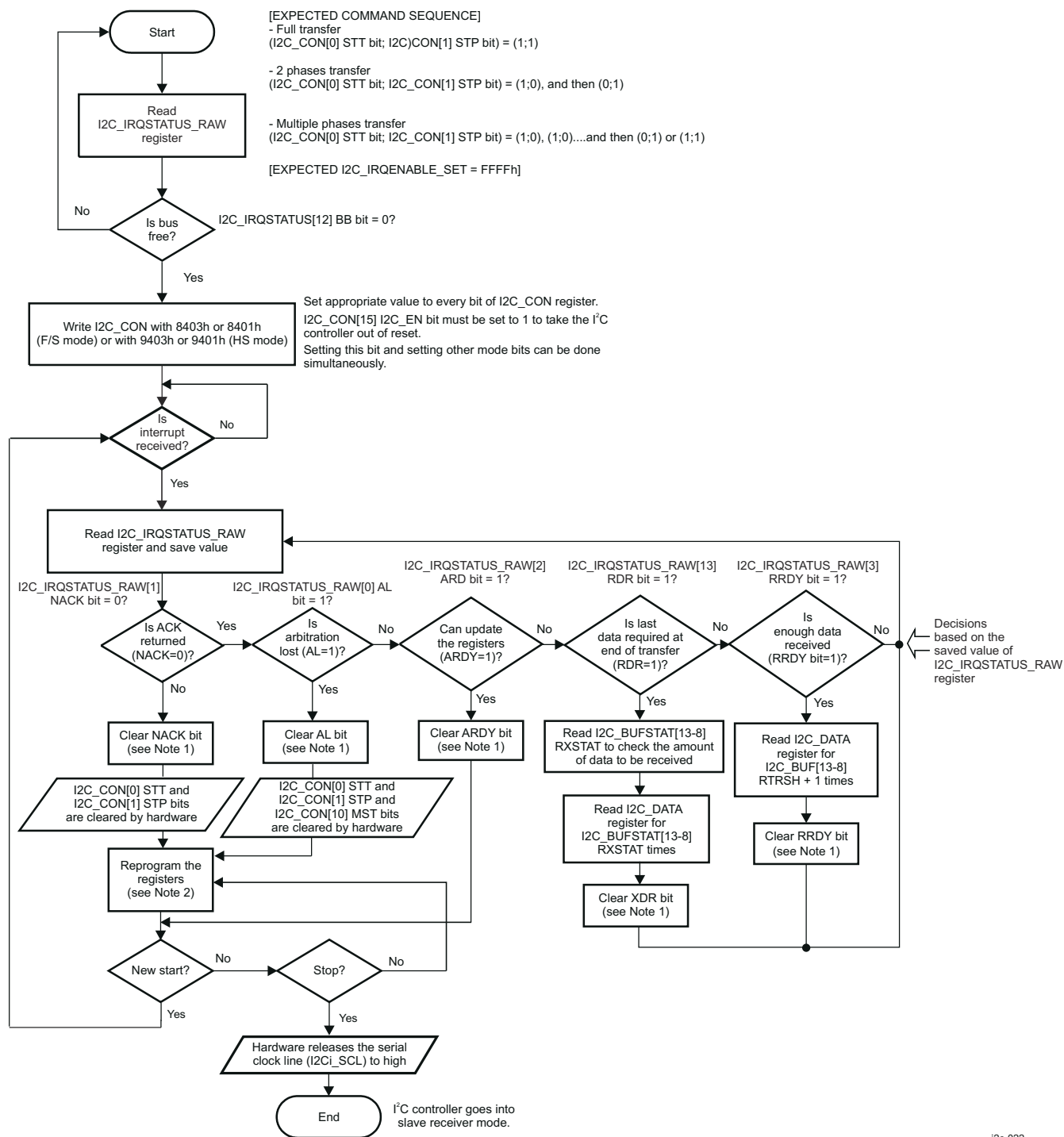

i2c-022

- A. The NACK, AL, ARDY, RDR, and RRDY bits are cleared by writing 1 to each corresponding bit in the I2C_IRQSTATUS register.
- B. Reprogram registers means: I2C_CON[11] STB and/or I2C_CON[10] MST bit and/or I2C_SA[9-0] SA register and/or I2C_CNT[15-0] DCOUNT register and/or I2C_CON[0] STT bit and/or I2C_CON[1] STP bit.

Figure 13-26. I2C Master Receiver Mode, Interrupt Method, in F/S and HS Modes

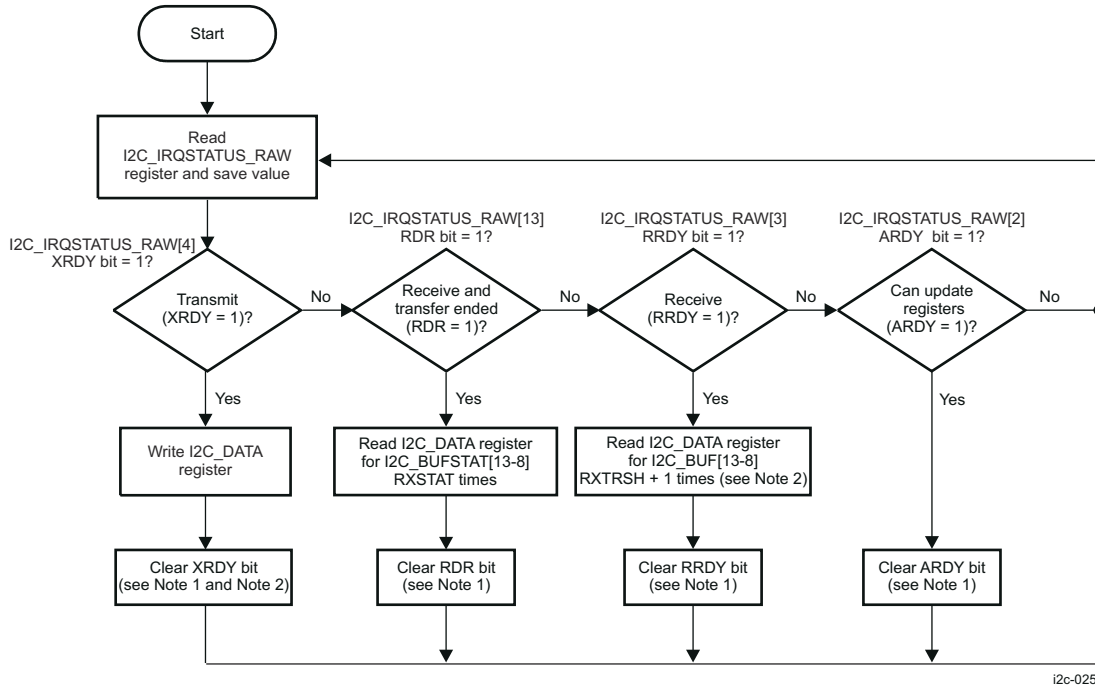

i2c-025

- A. The XRDY, RDR, RRDY, and ARDY bits are cleared by writing 1 to each corresponding bit in the I2C_IRQSTATUS register.
- B. In slave transmitter mode, the amount of data requested by the external master I²C device is unknown; thus, the I2C_BUF[5-0] XTRSH bit field must be configured to 0x0 (TX threshold = 1).

Figure 13-27. I2C Slave Transmitter/Receiver Mode, Polling

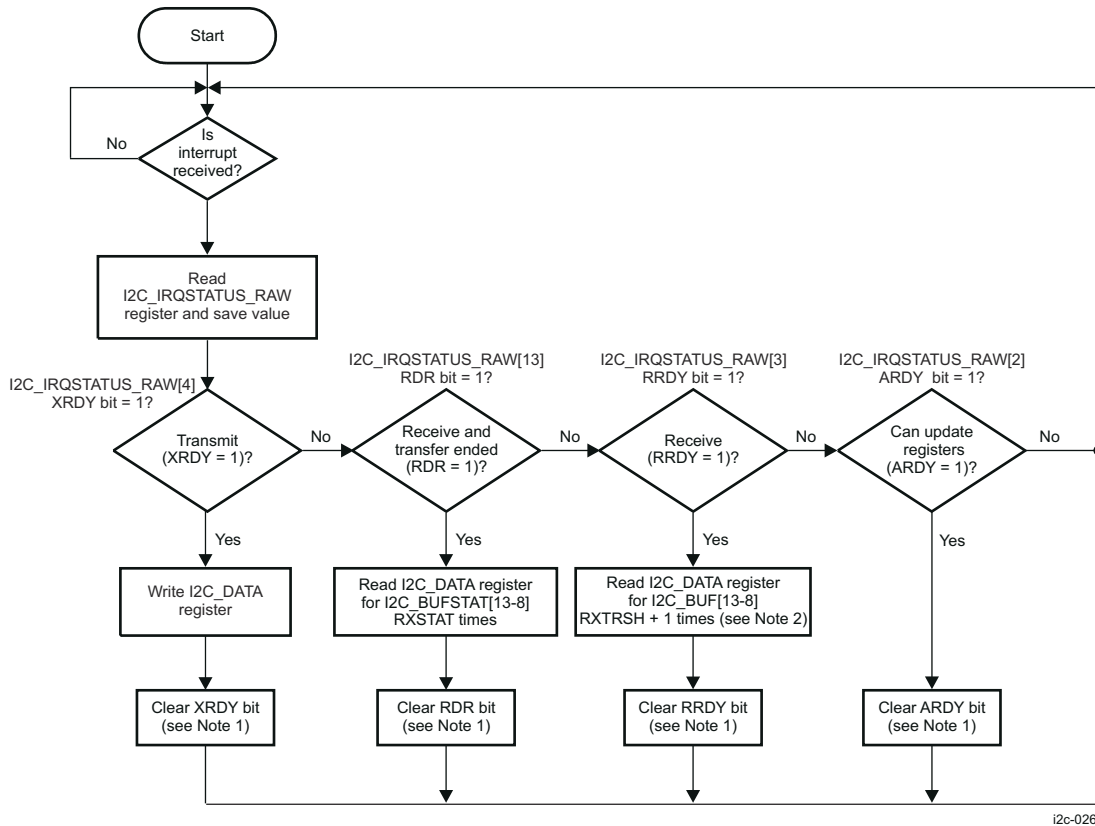

i2c-026

- A. The XRDY, RDR, RRDY, and ARDY bits are cleared by writing 1 to each corresponding bit in the I2C_IRQSTATUS register.

- B. In slave transmitter mode, the amount of data requested by the external master I²C device is unknown; thus, the I2C_BUF[5-0] XTRSH bit field must be configured to 0x0 (TX threshold = 1).

Figure 13-28. I2C Slave Transmitter/Receiver Mode, Interrupt

13.1.3 Multichannel Serial Peripheral Interface (MCSPI)

This section describes the Multichannel Serial Peripheral Interface (MCSPI) modules for the device.

13.1.3.1 MCSIPI Overview	928
13.1.3.2 SPI Environment	929
13.1.3.3 MCSIPI Integration	936
13.1.3.4 MCSIPI Functional Description	943
13.1.3.5 MCSIPI Programming Guide	964

13.1.3.1 MCSPI Overview

The MCSPI (SPI) module is a multichannel transmit/receive, controller/peripheral synchronous serial bus. There are 5 SPI modules in the device.

13.1.3.1.1 MCSPI Features

The MCSPI modules include the following main features:

- Serial clock with programmable frequency, polarity, and phase for each channel
- Wide selection of SPI word lengths, ranging from 4 to 32 bits
- Up to two channels in controller mode, or single channel in receive mode
- Each SPI controller operates at up to 50 MHz
- SPI0 and SPI4 support 2 chip selects while SPI1, SPI2, and SPI3 support 1 chip select
- Supports DMA access
- Controller multichannel mode:
 - Full duplex/half duplex
 - Transmit-only/receive-only/transmit-and-receive modes
 - Flexible input/output (I/O) port controls per channel
 - Programmable clock granularity
 - Per channel configuration for clock definition, polarity enabling, and word width
- Single interrupt line for multiple interrupt source events
- Enable the addition of a programmable start-bit for MCSPI transfer per channel (start-bit mode)
- Supports start-bit write command
- Supports start-bit pause and break sequence
- Programmable shift operations (1-32 bits)
- Programmable timing control between chip select and external clock generation
- Built-in FIFO available for a single channel

13.1.3.1.2 MCSPI Not Supported Features

The following features are not supported on this family of devices:

- Peripheral mode wake-up
- Retention during power down
- In peripheral mode only channel 0 is used
- Local power management of clock activity.

13.1.3.2 SPI Environment

The SPI[0:4] modules are hereinafter referred to as the SPI or MCSPI module.

This section describes the SPI external connections (environment).

13.1.3.2.1 MCSPI Protocol and Data Format

The synchronous MCSPI protocol allows a controller device to initiate serial data transfers to a peripheral device. A peripheral select line (SPIEN[i]) allows selection of an individual peripheral MCSPI device. Peripheral devices that are not selected do not interfere with MCSPI bus activities.

MCSPI offers the flexibility to modify the following parameters to adapt to the device features:

- Word length

MCSPI supports any MCSPI word ranging from 4 bits to 32 bits long (the MCSPI_CHCONF_0/1/2/3[11-7] WL bit field).

MCSPI word length can be changed between transmissions to allow the controller device to communicate with peripheral peripherals that have different requirements.

- MCSPI enable (SPIEN[i], for channel i)

The polarity of the MCSPI enable signals is programmable (the MCSPI_CHCONF_0/1/2/3[6] EPOL bit). SPIEN[i] signals can be active high or low.

Assertion of the SPIEN[i] signals is programmable and can be done manually or automatically. The manual assertion mode is available in single controller mode only. SPIEN[i] can be kept active between words with the MCSPI_CHCONF_0/1/2/3[20] FORCE bit.

Two consecutive words for two different peripheral devices can go along with active SPIEN[i] signals with different polarity.

- Programmable start-bit

In start-bit mode a start-bit is added before the MCSPI word length to indicate how the next MCSPI word must be handled. The start-bit is enabled by setting the MCSPI_CHCONF_0/1/2/3[23] SBE bit to 1. The MCSPI_CHCONF_0/1/2/3[24] SBPOL bit defines the polarity of the start-bit.

- Programmable MCSPI clock

- Bit rate

In controller mode, the baud rate of the MCSPI serial clock is programmable using the 50-MHz reference clock (from the device clock management module). [Table 13-21](#) lists the SPICLK bit rates obtained for data transfer when programming the clock divider (the MCSPI_CHCONF_0/1/2/3[5-2] CLKD bit field).

Table 13-21. MCSPI Controller Clock Rates

Divider	Clock Rate
1	50 MHz ⁽¹⁾
2	25 MHz ⁽¹⁾
4	12.5 MHz
8	6.25 MHz
16	3.125 MHz
32	1.5625 MHz
64	781.25 kHz
128	390.625 kHz
256	~195 kHz
512	~97.7 kHz
1024	~48.8 kHz
2048	~24.4 kHz
4096	~12.2 kHz

(1) These frequencies are not necessarily supported by all MCSPI modules. For more information, see the *Timing Requirements*

and *Switching Characteristics* chapter in the device-specific Datasheet.

– Polarity and phase

The polarity (the MCSPI_CHCONF_0/1/2/3[1] POL bit) and the phase (the MCSPI_CHCONF_0/1/2/3[0] PHA bit) of the MCSPI serial clock (SPICLK) are configurable to offer four combinations. Software selects the right combination, depending on the device. See [Table 13-22](#) and [Figure 13-29](#).

Table 13-22. Phase and Polarity Combinations

Polarity (POL)	Phase (PHA)	MCSPI Mode	Description
0	0	Mode 0	SPICLK is inactive low and sampling occurs at the rising edge.
0	1	Mode 1	SPICLK is inactive low and sampling occurs at the falling edge.
1	0	Mode 2	SPICLK is inactive high and sampling occurs at the falling edge.
1	1	Mode 3	SPICLK is inactive high and sampling occurs at the rising edge.

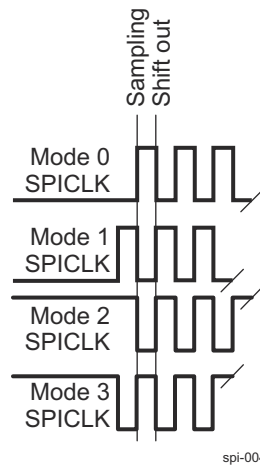

Figure 13-29. Phase and Polarity Combinations

13.1.3.2.1.1 Transfer Format

In controller and peripheral modes, the MCSPI drives the data lines when SPIEN[i] is asserted.

Each word is transmitted starting with the most-significant bit (MSB).

This section explains the two cases of data transmission determined by the clock phase (PHA) and the type of data transmission using a start-bit (SBE) called the start-bit mode:

- Transmission in mode 0 and mode 2 (PHA = 0)

When PHA = 0, the first bit of the MCSPI word to transmit (on the controller or the peripheral data output pin) is valid one-half cycle of SPICLK after the assertion of SPIEN[i].

Therefore, the first edge of the SPICLK line is used by the controller to sample the first data bit sent by the peripheral. On the same edge, the first data bit sent by the controller is sampled by the peripheral.

On the next SPICLK edge, the received data bit is shifted into the receive shift register and a new data bit is transmitted on the serial data line.

This process continues for a number of pulses on the SPICLK line defined by the MCSPI word length programmed in the controller device, with data being latched on odd-numbered edges and shifted on even-numbered edges, see [Figure 13-30](#).

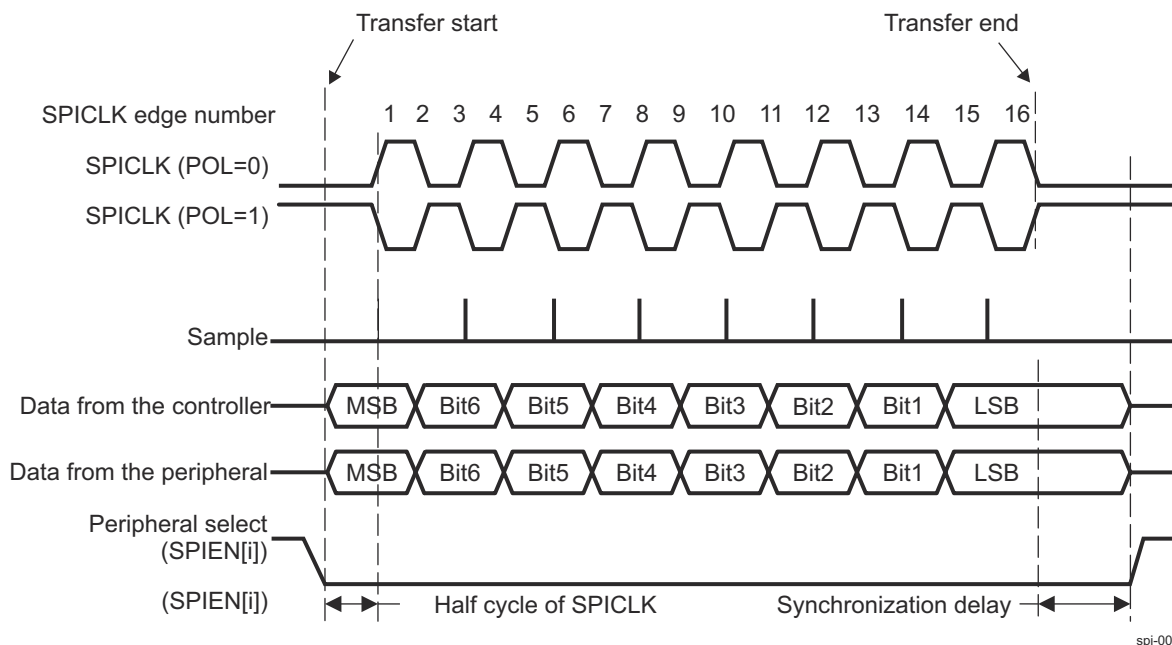

Figure 13-30. Full-Duplex Transfer Format With PHA = 0

- Transmission in mode 1 and mode 3 (PHA = 1)

When PHA = 1, the first bit of the MCSPI word to transmit (on the controller or the peripheral data output pin) is valid on the following SPICLK edge (one-half cycle later). This is the sampling edge for the controller and peripheral. A synchronization delay is added between the activation of SPIEN[i] and the first SPICLK edge.

The received data bit is shifted into the shift register on the third SPICLK edge.

This process continues for a number of pulses on the SPICLK line defined by the MCSPI word length programmed in the controller device, with data being latched on even-numbered edges and shifted on odd-numbered edges.

Note

The minimum synchronization delay is one cycle of SPICLK, if the frequency of SPICLK equals the frequency of MCSPI_FCLK (MCSPI functional clock) in controller mode. The minimum synchronization delay is one-half cycle of SPICLK, if the frequency of SPICLK is lower than the frequency of MCSPI_FCLK in the controller and peripheral modes.

- Transmission with a start-bit (SBE = 1)

When the MCSPI_CHCONF_0/1/2/3[23] SBE bit is set to 1, a start-bit is added before the MSB to indicate whether the next MCSPI word must be handled as a command or as data.

Figure 13-31 shows an example of a data transfer with an extra start-bit.

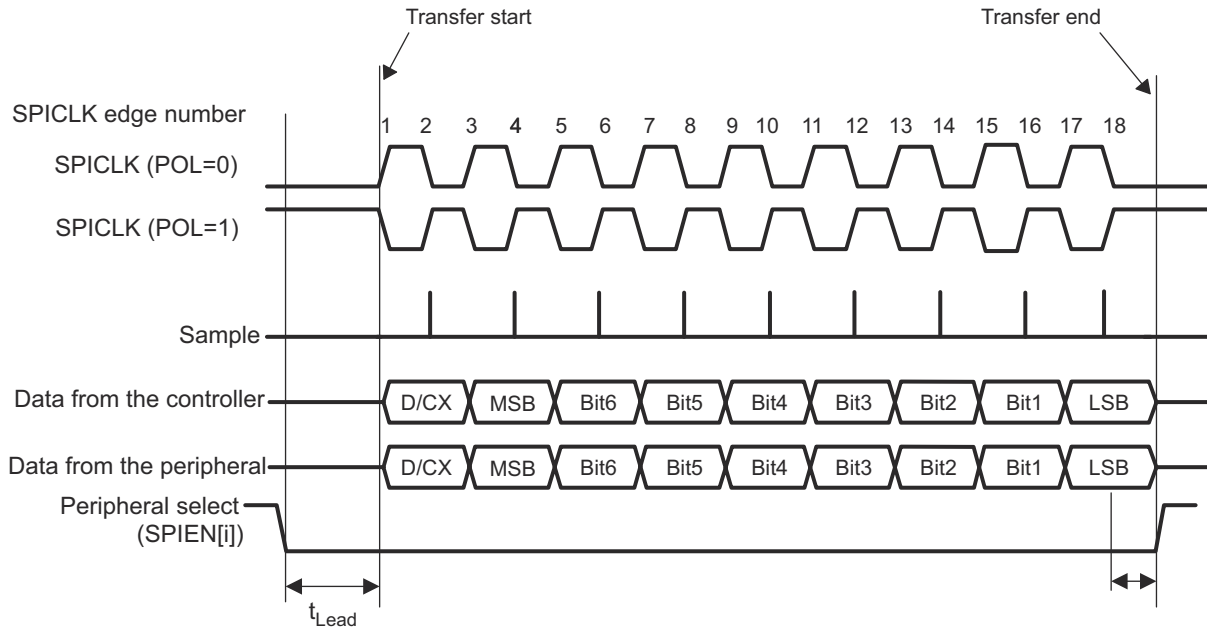

spi-006

Figure 13-31. Extended MCSPI Transfer With a Start-Bit (SBE = 1)

13.1.3.2.2 MCSPI in Controller Mode

shows a case in controller mode (full-duplex) where the MCSPI module is connected with two peripheral devices.

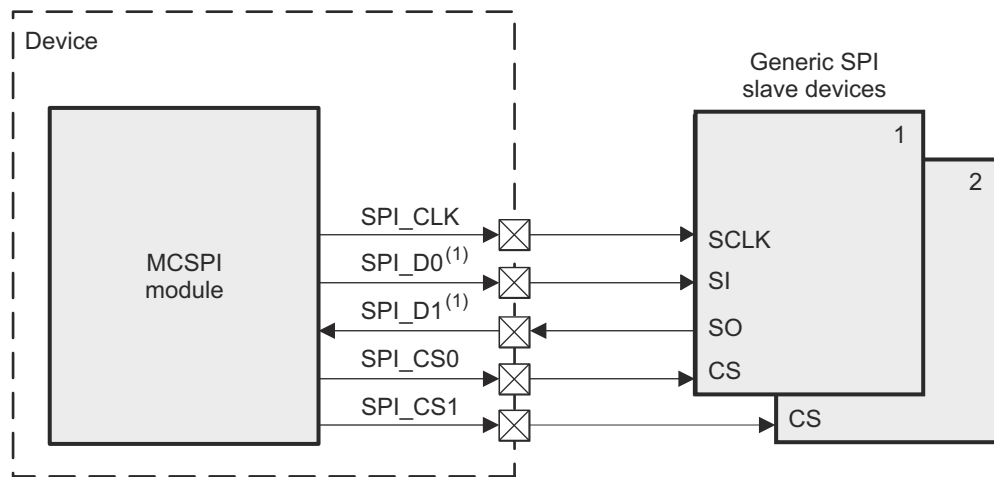

spi-007

- A. Direction depends on MCSPI_CHCONF_0/1/2/3[16] DPE0, MCSPI_CHCONF_0/1/2/3[17] DPE1 and MCSPI_CHCONF_0/1/2/3[18] IS bits

Figure 13-32. MCSPI Controller Mode (Full Duplex)

shows the controller single mode, which can also be configured in receive-only mode.

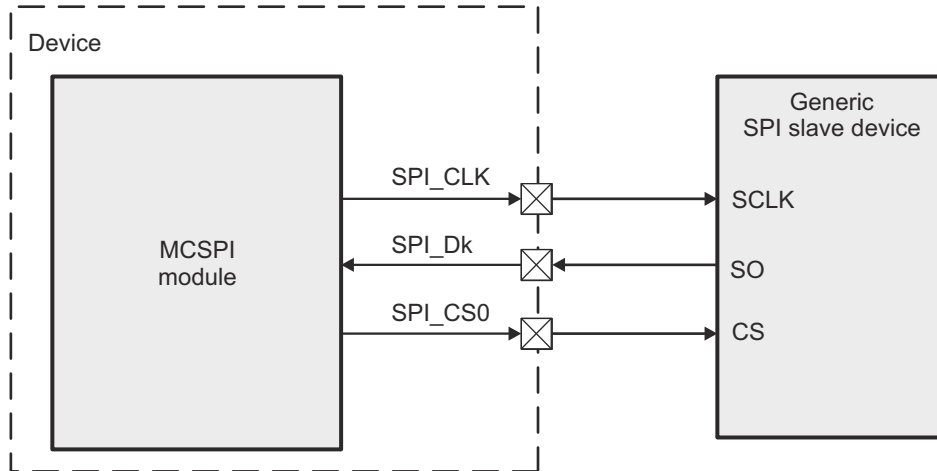

spi-008

k = 0 or 1 depending on MCSPI_CHCONF_0/1/2/3[16] DPE0, MCSPI_CHCONF_0/1/2/3[17] DPE1 and MCSPI_CHCONF_0/1/2/3[18] IS bits

Figure 13-33. MCSPI Controller Single Mode (Receive Only)

13.1.3.2.3 MCSPI in Peripheral Mode

shows a case in peripheral mode (full-duplex).

Note

Only channel 0 can be configured as peripheral, but the chip-enable signal can be connected to any SPIEN[i] pin and then rerouted internally to channel 0 (the MCSPI_CHCONF_0[22-21] SPIENSLV bit field). For more information, see , *MCSPI Peripheral Mode*.

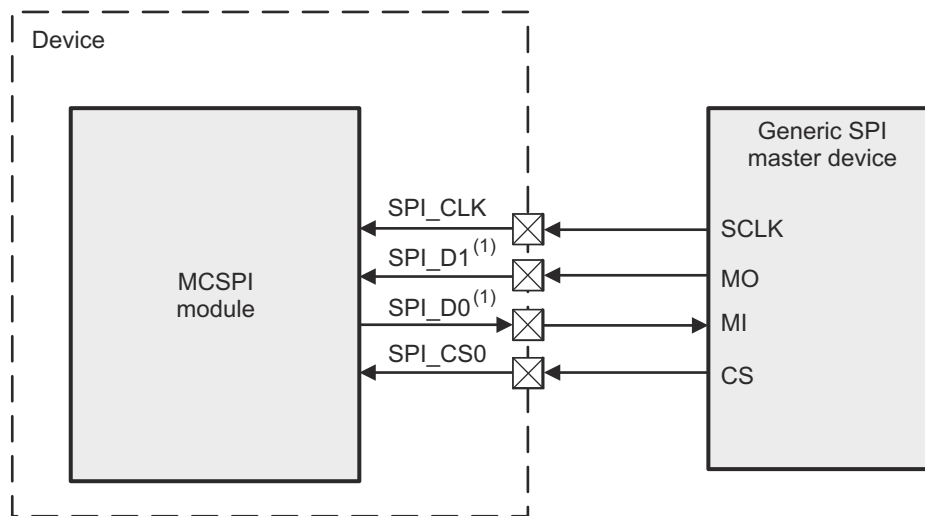

spi-009

A. Direction depends on MCSPI_CHCONF_0/1/2/3[16] DPE0, MCSPI_CHCONF_0/1/2/3[17] DPE1 and MCSPI_CHCONF_0/1/2/3[18] IS bits

Figure 13-34. MCSPI Peripheral Mode (Full Duplex)

shows the peripheral single mode, which can also be configured in transmit-only mode.

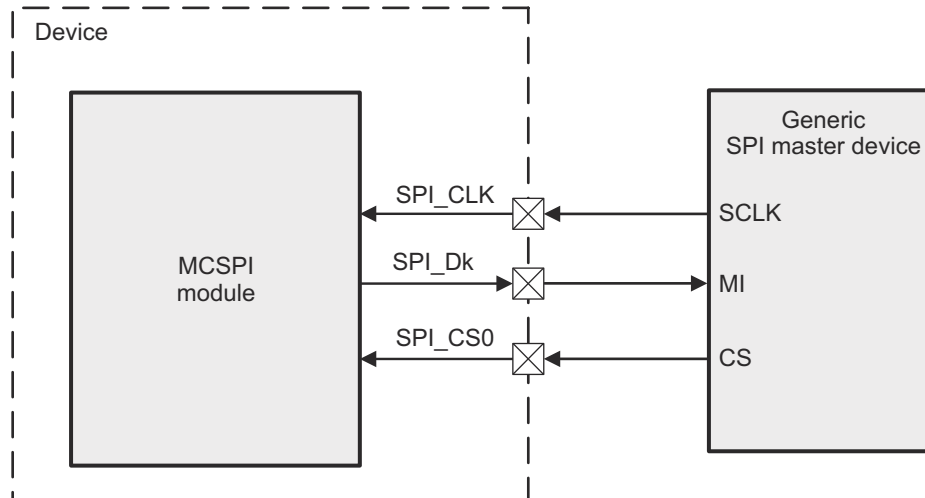

spl-010

k = 0 or 1 depending on MCSPI_CHCONF_0/1/2/3[16] DPE0, MCSPI_CHCONF_0/1/2/3[17] DPE1 and MCSPI_CHCONF_0/1/2/3[18] IS bits

Figure 13-35. MCSPI Peripheral Single Mode (Transmit Only)

13.1.3.3 MCSPI Integration

This section describes module integration in the device, including information about clocks, resets, and hardware requests.

13.1.3.3.1 SPI Integration

There are 5x SPI modules integrated in the device. The diagram below provides a visual representation of the device integration details.

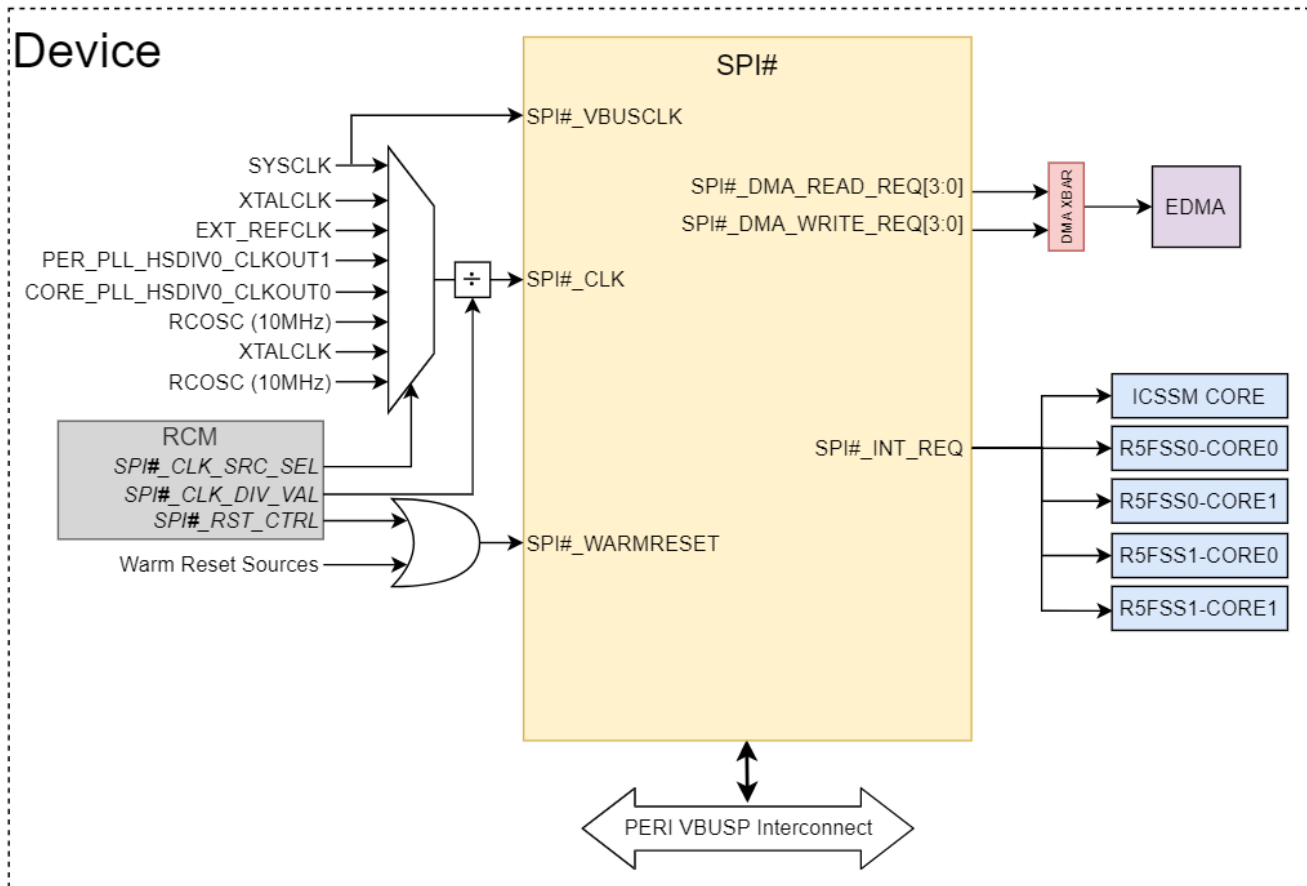

ADVANCE INFORMATION

Figure 13-36. SPI Integration

The tables below summarize the device integration details of SPI# (where # = 0, 1, 2, 3, 4).

Table 13-23. SPI/Device Integration

This table describes the module device integration details.

Module Instance	Device Allocation	SoC Interconnect
SPI0	✓	PERI VBUSP Interconnect
SPI1	✓	PERI VBUSP Interconnect
SPI2	✓	PERI VBUSP Interconnect
SPI3	✓	PERI VBUSP Interconnect
SPI4	✓	PERI VBUSP Interconnect

Table 13-24. SPIClocks

This table describes the module clocking signals.

Module Instance	Module Clock Input	Source Clock Signal	Source	Default Freq	Description
SPI0	SPI0_ICLK (VBUSP_CLK)	SYS_CLK	PLL_CORE_CLK: HSDIV0_CLKOUT0	200 MHz	SPI0 VBUS Clock
	SPI0_FCLK (SPI_CLK)	XTALCLK	External XTAL	25 MHz	SPI0 Interface Clock
		EXT_REFCLK	External Reference Clock (EXT_REFCLK)	100 MHz	
		SYS_CLK	PLL_CORE_CLK: HSDIV0_CLKOUT0	200 MHz	
		DPLL_PER_HSDIV0_CLK OUT1	PLL_PER_CLK: HSDIV0_CLKOUT1	192 MHz	
		DPLL_CORE_HSDIV0_CLK KOUT0	PLL_CORE_CLK: HSDIV0_CLKOUT1	400 MHz	
		RCCLK10M	Internal 10 MHz RC Oscillator (RCCLK10M)	10 MHz	
		XTALCLK	External XTAL	25 MHz	
		RCCLK10M	Internal 10 MHz RC Oscillator (RCCLK10M)	10 MHz	
SPI1	SPI1_ICLK (VBUSP_CLK)	SYS_CLK	PLL_CORE_CLK: HSDIV0_CLKOUT0	200 MHz	SPI1 VBUS Clock
	SPI1_FCLK (SPI_CLK)	XTALCLK	External XTAL	25 MHz	SPI1 Interface Clock
		EXT_REFCLK	External Reference Clock (EXT_REFCLK)	100 MHz	
		SYS_CLK	PLL_CORE_CLK: HSDIV0_CLKOUT0	200 MHz	
		DPLL_PER_HSDIV0_CLK OUT1	PLL_PER_CLK: HSDIV0_CLKOUT1	192 MHz	
		DPLL_CORE_HSDIV0_CLK KOUT0	PLL_CORE_CLK: HSDIV0_CLKOUT1	400 MHz	
		RCCLK10M	Internal 10 MHz RC Oscillator (RCCLK10M)	10 MHz	
		XTALCLK	External XTAL	25 MHz	
		RCCLK10M	Internal 10 MHz RC Oscillator (RCCLK10M)	10 MHz	

Table 13-24. SPIClocks (continued)

This table describes the module clocking signals.

Module Instance	Module Clock Input	Source Clock Signal	Source	Default Freq	Description
SPI2	SPI2_ICLK (VBUSP_CLK)	SYS_CLK	PLL_CORE_CLK: HSDIV0_CLKOUT0	200 MHz	SPI2 VBUS Clock
	SPI2_FCLK (SPI_CLK)	XTALCLK	External XTAL	25 MHz	SPI2 Interface Clock
		EXT_REFCLK	External Reference Clock (EXT_REFCLK)	100 MHz	
		SYS_CLK	PLL_CORE_CLK: HSDIV0_CLKOUT0	200 MHz	
		DPLL_PER_HSDIV0_CLK OUT1	PLL_PER_CLK: HSDIV0_CLKOUT1	192 MHz	
		DPLL_CORE_HSDIV0_CL KOUT0	PLL_CORE_CLK: HSDIV0_CLKOUT1	400 MHz	
		RCCLK10M	Internal 10 MHz RC Oscillator (RCCLK10M)	10 MHz	
		XTALCLK	External XTAL	25 MHz	
		RCCLK10M	Internal 10 MHz RC Oscillator (RCCLK10M)	10 MHz	
SPI3	SPI3_ICLK (VBUSP_CLK)	SYS_CLK	PLL_CORE_CLK: HSDIV0_CLKOUT0	200 MHz	SPI3 VBUS Clock
	SPI3_FCLK (SPI_CLK)	XTALCLK	External XTAL	25 MHz	SPI3 Interface Clock
		EXT_REFCLK	External Reference Clock (EXT_REFCLK)	100 MHz	
		SYS_CLK	PLL_CORE_CLK: HSDIV0_CLKOUT0	200 MHz	
		DPLL_PER_HSDIV0_CLK OUT1	PLL_PER_CLK: HSDIV0_CLKOUT1	192 MHz	
		DPLL_CORE_HSDIV0_CL KOUT0	PLL_CORE_CLK: HSDIV0_CLKOUT1	400 MHz	
		RCCLK10M	Internal 10 MHz RC Oscillator (RCCLK10M)	10 MHz	
		XTALCLK	External XTAL	25 MHz	
		RCCLK10M	Internal 10 MHz RC Oscillator (RCCLK10M)	10 MHz	

Table 13-24. SPI Clocks (continued)

This table describes the module clocking signals.

Module Instance	Module Clock Input	Source Clock Signal	Source	Default Freq	Description
SPI4	SPI4_ICLK (VBUSP_CLK)	SYS_CLK	PLL_CORE_CLK: HSDIV0_CLKOUT0	200 MHz	SPI4 VBUS Clock
	SPI4_FCLK (SPI_CLK)	XTALCLK	External XTAL	25 MHz	SPI4 Interface Clock
		EXT_REFCLK	External Reference Clock (EXT_REFCLK)	100 MHz	
		SYS_CLK	PLL_CORE_CLK: HSDIV0_CLKOUT0	200 MHz	
		DPLL_PER_HSDIV0_CLK OUT1	PLL_PER_CLK: HSDIV0_CLKOUT1	192 MHz	
		DPLL_CORE_HSDIV0_CL KOUT0	PLL_CORE_CLK: HSDIV0_CLKOUT1	400 MHz	
		RCCLK10M	Internal 10 MHz RC Oscillator (RCCLK10M)	10 MHz	
		XTALCLK	External XTAL	25 MHz	
		RCCLK10M	Internal 10 MHz RC Oscillator (RCCLK10M)	10 MHz	

Table 13-25. SPI Resets

This table describes the module reset signals.

Module Instance	Module Reset Input	Source Reset Signal	Source	Description
SPI0	SPI0_RST	Warm Reset (MOD_G_RST)	RCM + Warm Reset Sources	SPI0 Asynchronous Reset
SPI1	SPI1_RST	Warm Reset (MOD_G_RST)	RCM + Warm Reset Sources	SPI1 Asynchronous Reset
SPI2	SPI2_RST	Warm Reset (MOD_G_RST)	RCM + Warm Reset Sources	SPI2 Asynchronous Reset
SPI3	SPI3_RST	Warm Reset (MOD_G_RST)	RCM + Warm Reset Sources	SPI3 Asynchronous Reset
SPI4	SPI4_RST	Warm Reset (MOD_G_RST)	RCM + Warm Reset Sources	SPI4 Asynchronous Reset

Table 13-26. SPI Interrupt Requests

This table describes the module interrupt requests.

Module Instance	Module Interrupt Signal	Destination Interrupt Input	Destination	Type	Description
SPI0	spi0_int_req	spi0_int_req	ALL R5FSS Cores ICSSM Core	Level	SPI0 IP Status Information
SPI1	spi1_int_req	spi1_int_req	ALL R5FSS Cores ICSSM Core	Level	SPI1 IP Status Information
SPI2	spi2_int_req	spi2_int_req	ALL R5FSS Cores ICSSM Core	Level	SPI2 IP Status Information
SPI3	spi3_int_req	spi3_int_req	ALL R5FSS Cores ICSSM Core	Level	SPI3 IP Status Information

Table 13-26. SPI Interrupt Requests (continued)

This table describes the module interrupt requests.

Module Instance	Module Interrupt Signal	Destination Interrupt Input	Destination	Type	Description
SPI4	spi4_int_req	spi4_int_req	ALL R5FSS Cores ICSSM Core	Level	SPI4 IP Status Information

Table 13-27. SPI DMA Requests

This table describes the module DMA requests.

Module Instance	Module DMA Event	Destination DMA Event Input	Destination	Type	Description
SPI0	SPI0_DMA_READ_0	spi0_dma_read_req[0]	EDMA Crossbar (EDMA_XBAR)	Level	SPI0 DMA Read Request
	SPI0_DMA_READ_1	spi0_dma_read_req[1]			
	SPI0_DMA_READ_2	spi0_dma_read_req[2]			
	SPI0_DMA_READ_3	spi0_dma_read_req[3]			
	SPI0_DMA_WRITE_0	spi0_dma_write_req[0]			SPI0 DMA Write Request
	SPI0_DMA_WRITE_1	spi0_dma_write_req[1]			
	SPI0_DMA_WRITE_2	spi0_dma_write_req[2]			
	SPI0_DMA_WRITE_3	spi0_dma_write_req[3]			
SPI1	SPI1_DMA_READ_0	spi1_dma_read_req[0]	EDMA Crossbar (EDMA_XBAR)	Level	SPI1 DMA Read Request
	SPI1_DMA_READ_1	spi1_dma_read_req[1]			
	SPI1_DMA_READ_2	spi1_dma_read_req[2]			
	SPI1_DMA_READ_3	spi1_dma_read_req[3]			
	SPI1_DMA_WRITE_0	spi1_dma_write_req[0]			SPI1 DMA Write Request
	SPI1_DMA_WRITE_1	spi1_dma_write_req[1]			
	SPI1_DMA_WRITE_2	spi1_dma_write_req[2]			
	SPI1_DMA_WRITE_3	spi1_dma_write_req[3]			
SPI2	SPI2_DMA_READ_0	spi2_dma_read_req[0]	EDMA Crossbar (EDMA_XBAR)	Level	SPI2 DMA Read Request
	SPI2_DMA_READ_1	spi2_dma_read_req[1]			
	SPI2_DMA_READ_2	spi2_dma_read_req[2]			
	SPI2_DMA_READ_3	spi2_dma_read_req[3]			
	SPI2_DMA_WRITE_0	spi2_dma_write_req[0]			SPI2 DMA Write Request
	SPI2_DMA_WRITE_1	spi2_dma_write_req[1]			
	SPI2_DMA_WRITE_2	spi2_dma_write_req[2]			
	SPI2_DMA_WRITE_3	spi2_dma_write_req[3]			
SPI3	SPI3_DMA_READ_0	spi3_dma_read_req[0]	EDMA Crossbar (EDMA_XBAR)	Level	SPI3 DMA Read Request
	SPI3_DMA_READ_1	spi3_dma_read_req[1]			
	SPI3_DMA_READ_2	spi3_dma_read_req[2]			
	SPI3_DMA_READ_3	spi3_dma_read_req[3]			
	SPI3_DMA_WRITE_0	spi3_dma_write_req[0]			SPI3 DMA Write Request
	SPI3_DMA_WRITE_1	spi3_dma_write_req[1]			
	SPI3_DMA_WRITE_2	spi3_dma_write_req[2]			
	SPI3_DMA_WRITE_3	spi3_dma_write_req[3]			

Table 13-27. SPI DMA Requests (continued)

This table describes the module DMA requests.

Module Instance	Module DMA Event	Destination DMA Event Input	Destination	Type	Description
SPI4	SPI4_DMA_READ_0	spi4_dma_read_req[0]	EDMA Crossbar (EDMA_XBAR)	Level	SPI4 DMA Read Request
	SPI4_DMA_READ_1	spi2_dma_read_req[1]			
	SPI4_DMA_READ_2	spi4_dma_read_req[2]			
	SPI4_DMA_READ_3	spi4_dma_read_req[3]			
	SPI4_DMA_WRITE_0	spi4_dma_write_req[0]			SPI4 DMA Write Request
	SPI4_DMA_WRITE_1	spi4_dma_write_req[1]			
	SPI4_DMA_WRITE_2	spi4_dma_write_req[2]			
	SPI4_DMA_WRITE_3	spi4_dma_write_req[3]			

Note

For more information on the interconnects, see the *System Interconnect* chapter.

For more information on power, reset, and clock management, see the corresponding sections within the *Device Configuration* chapter.

For more information on the device interrupt controllers, see the *Interrupt Controllers* chapter.

13.1.3.4 MCSPI Functional Description

13.1.3.4.1 MCSPI Block Diagram

Figure 13-37 shows the MCSPI module.

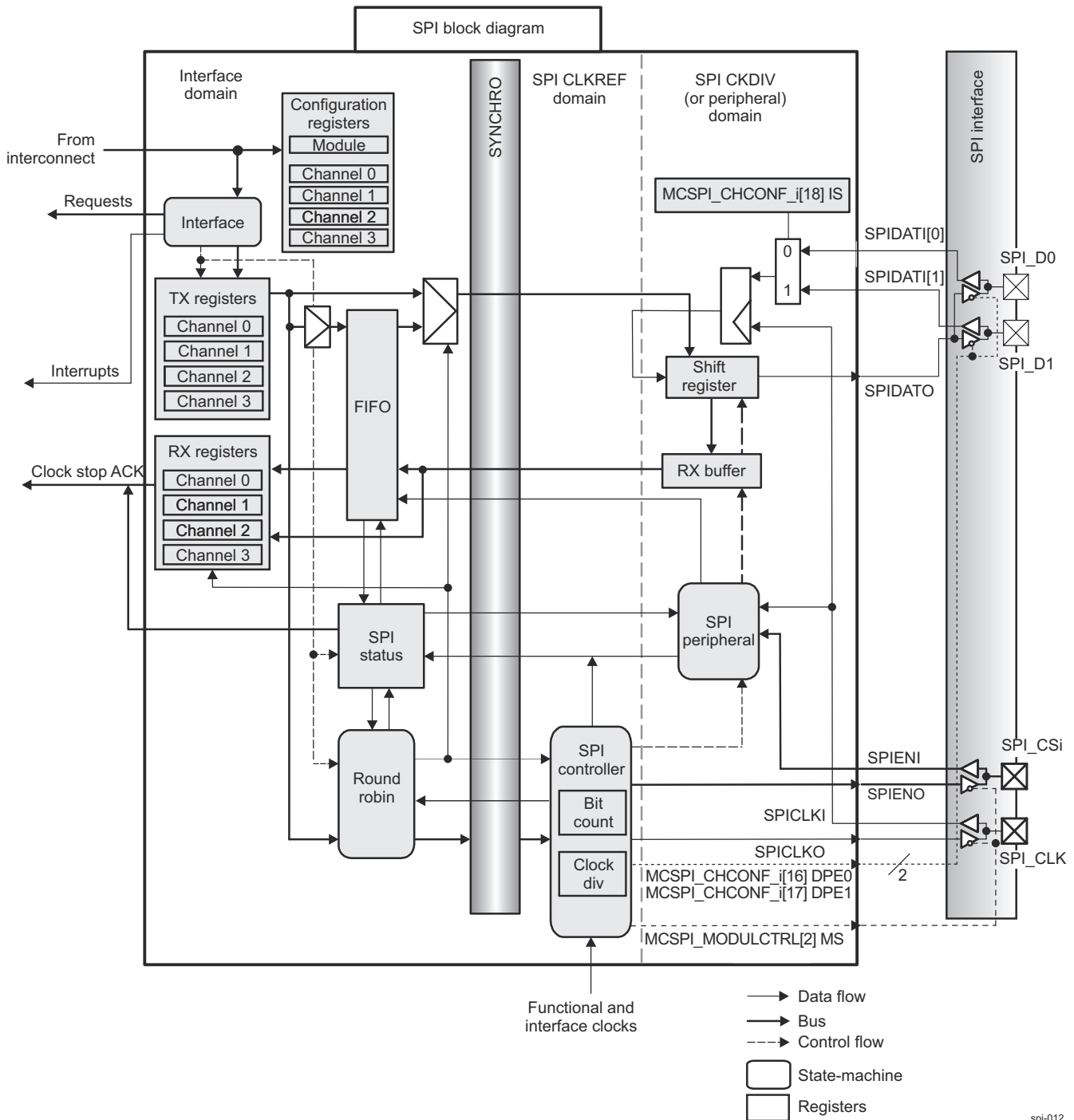

ADVANCE INFORMATION

Figure 13-37. MCSPI Block Diagram

13.1.3.4.2 MCSPI Reset

The MCSPI module can be reset either by hardware or by software reset. All configuration registers and all state machines are reset by the hardware reset signal (MCSPI_RST). MCSPI can be reset by software through the

MCSPi_SYSCONFIG[1] SOFTRESET bit. This bit has the same impact on the module as the hardware reset signal. The only exception is that the MCSPi_SYSCONFIG register is not affected by that software reset.

13.1.3.4.3 MCSPi Controller Mode

13.1.3.4.3.1 Controller Mode Features

The MCSPi controller mode supports multichannel communication with up to four independent MCSPi communication channel contexts. The MCSPi initiates a data transfer on the data lines (SPIDAT[0] and SPIDAT[1]) and generates clock (SPICLK) and control (SPIEN[i]) signals.

Connected to multiple external devices, the MCSPi exchanges data with one MCSPi device at a time through two main modes (available in peripheral mode):

- Two-data-pins interface mode (transmit-and-receive mode for full-duplex transmission)
- Single-data-pin interface mode (recommended for half-duplex transmission)

Note

There is a fixed chip select line allocation in multichannel controller mode. Channel *i* is mapped to SPIEN[i].

Two DMA request events (read and write) allow synchronized accesses of the DMA controller with the activity of MCSPi.

Three interrupt events can be used for data transmission and reception in controller mode (for more information about interrupts, see [Section 13.1.3.4.7.1, Interrupt Events in Controller Mode](#)).

13.1.3.4.3.2 Controller Transmit-and-Receive Mode (Full Duplex)

In full-duplex transmission, data is transmitted (shifted out serially on SPIDAT[0]) and received (shifted in serially on SPIDAT[1]) simultaneously on separate data lines.

The controller transmit-and-receive mode is programmable per channel (the MCSPi_CHCONF_0/1/2/3[13-12] TRM bit field).

Channel access to the shift registers for transmission/reception is based on the MCSPi_TX_0/1/2/3 transmitter register state, the MCSPi_RX_0/1/2/3 receiver register state, and round-robin arbitration.

Channels that meet the following rules are included in the round-robin list of active channels scheduled for transmission and/or reception. The arbiter skips channels that do not meet the rules and searches in the rotation for the next enabled channel.

- Rule 1: Only enabled channels (the MCSPi_CHCTRL_0/1/2/3[0] EN bit) can be scheduled for transmission and/or reception.
- Rule 2: If its MCSPi_TX_0/1/2/3 transmitter register is not empty (the MCSPi_CHSTAT_0/1/2/3[1] TXS bit), an enabled channel can be scheduled when the shift register is assigned. If the MCSPi_TX_0/1/2/3 register is empty when the shift register is assigned, the TXx_UNDERFLOW event is activated, and the next enabled channel with new data to transmit is scheduled (see also transmit-only mode).
- Rule 3: An enabled channel can be scheduled if its receive register is not full (the MCSPi_CHSTAT_0/1/2/3[0] RXS bit) when the shift register is assigned (see also receive-only mode). Therefore, the MCSPi_RX_0/1/2/3 register cannot be overwritten. The MCSPi_IRQSTATUS[3] RX0_OVERFLOW bit is never set to this mode.

When MCSPi word transfer completes (the MCSPi_CHSTAT_0/1/2/3[2] EOT bit is set), the updated MCSPi_TX_0/1/2/3 register of the next scheduled channel is loaded into the shift register. The serialization (transmit-and-receive) starts depending on the channel communication configuration. When serialization completes, the received data transfers to the channel receive register.

The serial clock (SPICLK) synchronizes shifting and sampling of the information on the two serial data lines (SPIDAT[0] and SPIDAT[1]). Each time a bit transfers out from the controller, 1 bit transfers in from the peripheral.

Figure 13-38 shows an example of a full-duplex system with a controller device on the left and a peripheral device on the right. After eight cycles of the serial clock SPICLK, WordA transfers from the controller to the peripheral. At the same time, WordB transfers from the peripheral to the controller.

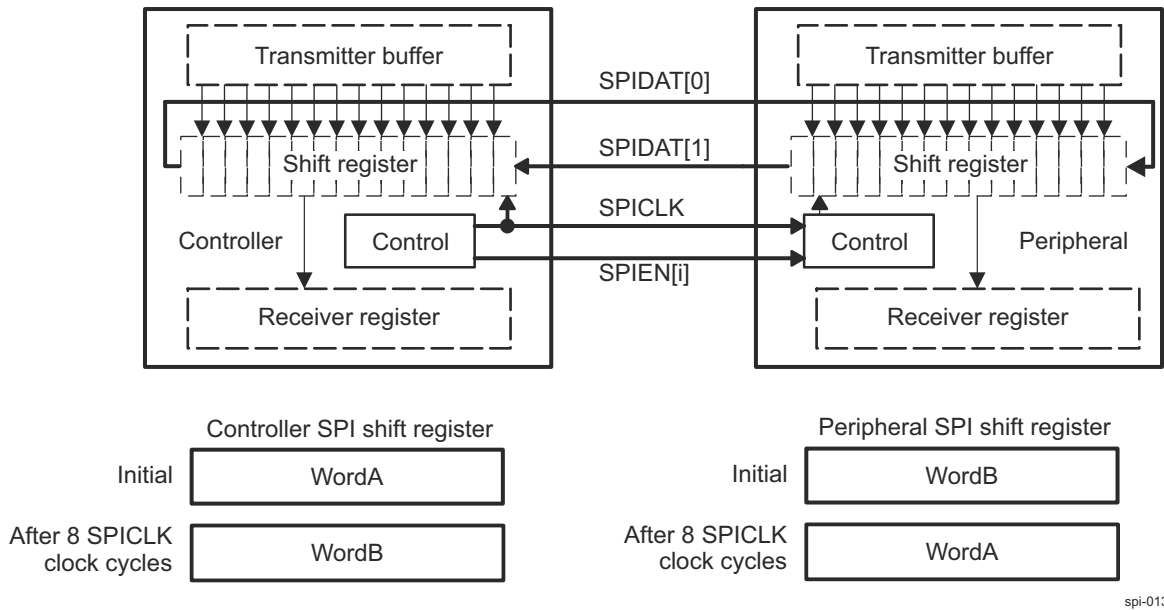

spi-013

Figure 13-38. MCSPi Full-Duplex Transmission (Example)

13.1.3.4.3.3 Controller Transmit-Only Mode (Half Duplex)

The controller transmit-only mode prevents the processor from reading the MCSPI_RX_0/1/2/3 register (minimizing data movement) when only transmission is meaningful.

The controller transmit-only mode is programmable per channel (the MCSPI_CHCONF_0/1/2/3[13-12] TRM bit field). Transmission starts only after data is loaded into the MCSPI_TX_0/1/2/3 register.

Rule 1 and Rule 2, defined in Section 13.1.3.4.3.2, apply in this mode.

Rule 3, defined in Section 13.1.3.4.3.2, does not apply.

In controller transmit-only mode, the MCSPI_RX_0/1/2/3 register state FULL does not prevent transmission and the MCSPI_RX_0/1/2/3 register is always overwritten with the new MCSPI word. This event is not significant when only transmission is meaningful. Thus, the RX0_OVERFLOW bit in the MCSPI_IRQSTATUS register is never set in this mode.

The hardware automatically disables the RX_FULL interrupt and the DMA read requests.

The transfer status is given by the MCSPI_CHSTAT_0/1/2/3[2] EOT bit.

13.1.3.4.3.4 Controller Receive-Only Mode (Half Duplex)

The controller receive mode prevents the processor from refilling the MCSPI_TX_0/1/2/3 register (minimizing data movement) when only reception is meaningful.

The controller receive mode is programmable per channel (the MCSPI_CHCONF_0/1/2/3[13-12] TRM bit field).

The controller receive-only mode enables channel scheduling only on the empty state of the MCSPI_RX_0/1/2/3 register.

Rule 1 and Rule 3, defined in Section 13.1.3.4.3.2, apply in this mode.

Rule 2, defined in Section 13.1.3.4.3.2, does not apply.

In the controller receive-only mode, software must write dummy data to the MCSPI_TX_0/1/2/3 register. Only one dummy write is enough to receive any number of words from the peripheral. Software must

ensure that the MCSPI_TX_0/1/2/3 register is always full (the TXx_EMPTY bits of MCSPI_IRQSTATUS) when receiving. The content of the MCSPI_TX_0/1/2/3 register is always loaded into the shift register when the shift register is assigned. After writing the dummy data to the MCSPI_TX_0/1/2/3 register, the TXx_EMPTY and TXx_UNDERFLOW bits in the MCSPI_IRQSTATUS register are never set in receive-only mode.

The MCSPI_CHSTAT_0/1/2/3[2] EOT bit gives the status of serialization. The RXx_FULL bits of the MCSPI_IRQSTATUS register are set when received data is loaded from the shift register to the corresponding MCSPI_RX_0/1/2/3 register. The MCSPI_IRQSTATUS[3] RX0_OVERFLOW bit is never set in this mode.

13.1.3.4.3.5 Single-Channel Controller Mode

When the MCSPI is configured as a controller device with a single enabled channel (MCSPI_MODULCTRL[2] MS = 0 and MCSPI_MODULCTRL[0] SINGLE = 1), the assertion of the SPIEN[i] signal is optional depending on device connected to the controller. In 3-pin mode (MCSPI_MODULCTRL[1] PIN34 = 1) the controller starts transmitting data when a write to the MCSPI_TX_0/1/2/3 register or the FIFO is performed. In 4-pin mode (MCSPI_MODULCTRL[1] PIN34 = 0) the assertion and de-assertion of SPIEN[i] is controlled by software using the MCSPI_CHCONF_0/1/2/3[20] FORCE bit.

13.1.3.4.3.5.1 Programming Tips When Switching to Another Channel

When a single channel is enabled and data transfer is ongoing:

- Wait for the MCSPI word transfer to complete (wait until the MCSPI_CHSTAT_0/1/2/3[2] EOT bit is set to 1) before disabling the current channel and enabling a different channel.
- Disable the current channel, and then enable the other channel.

13.1.3.4.3.5.2 Force SPIEN[i] Mode

Continuous transfers are allowed manually by keeping the SPIEN[i] signal active for successive MCSPI words transfer. Several sequences (configuration/enable/disable of the channel) can be run without deactivating the SPIEN[i] line. This mode is supported by all channels and any controller sequence can be used (transmit-receive, transmit-only, receive-only).

Keeping the SPIEN[i] active mode is supported when:

- A single channel is used (with the MCSPI_MODULCTRL[0] SINGLE bit set to 1).
- Transfer parameters are loaded in the configuration register of the appropriate channel (MCSPI_CHCONF_0/1/2/3).

The state of the SPIEN[i] signal is programmable:

- Writing 1 to the MCSPI_CHCONF_0/1/2/3[20] FORCE bit drives the SPIEN[i] line high when the MCSPI_CHCONF_0/1/2/3[6] EPOL bit is set to 0. SPIEN[i] is driven low when the MCSPI_CHCONF_0/1/2/3[6] EPOL bit is set to 1.
- Writing 0 to the MCSPI_CHCONF_0/1/2/3[20] FORCE bit drives the SPIEN[i] line low when the MCSPI_CHCONF_0/1/2/3[6] EPOL bit is set to 0. SPIEN[i] is driven high when the MCSPI_CHCONF_0/1/2/3[6] EPOL bit is set to 1.
- A single channel is enabled (the MCSPI_CHCTRL_0/1/2/3[0] EN bit is set to 1). The first enabled channel activates the SPIEN[i] line.

When the channel is enabled, the SPIEN[i] signal activates with the programmed polarity. As in the multichannel controller mode, the transfer start depends on the status of the MCSPI_TX_0/1/2/3 register (the MCSPI_CHSTAT_0/1/2/3[1] TXS bit), the status of the MCSPI_RX_0/1/2/3 register (the MCSPI_CHSTAT_0/1/2/3[1] RXS bit), and the defined mode (the MCSPI_CHCONF_0/1/2/3[13-12] TRM bit field) of the channel enabled.

The MCSPI_CHSTAT_0/1/2/3[2] EOT bit gives the transfer status of each MCSPI word. The RXx_FULL bit in the MCSPI_IRQSTATUS register is set when received data is loaded from the shift register to the MCSPI_RX_0/1/2/3 register.

A change in the configuration parameters is propagated directly on the MCSPI interface. If the SPIEN[i] signal is activated, ensure that the configuration is changed only between MCSPI words to avoid corrupting the current transfer.

Note

To avoid data corruption, SPIEN[i] polarity and SPICLK phase and SPICLK polarity must not be modified when the SPIEN[i] signal is activated.

A delay between MCSPI words that requires the connected MCSPI peripheral device to switch from one configuration to another (for instance, from transmit-only to receive-only) must be handled by software.

At the end of the last MCSPI word, the channel must be deactivated (the MCSPI_CHCTRL_0/1/2/3[0] EN bit set to 0) and SPIEN[i] can be forced to its INACTIVE state using the MCSPI_CHCONF_0/1/2/3[20] FORCE bit.

Figure 13-39 and Figure 13-40 show successive transfers with SPIEN[i] maintained active low with a different configuration for each MCSPI word in single-data-pin and dual-data-pin interface modes, respectively.

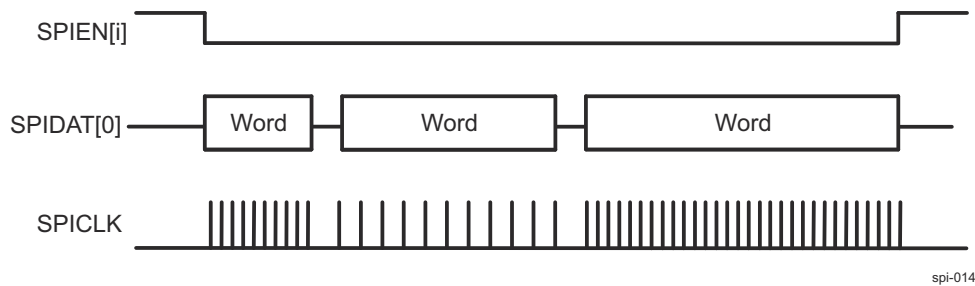

Figure 13-39. Continuous Transfers With SPIEN[i] Maintained Active (Single-Data-Pin Interface Mode)

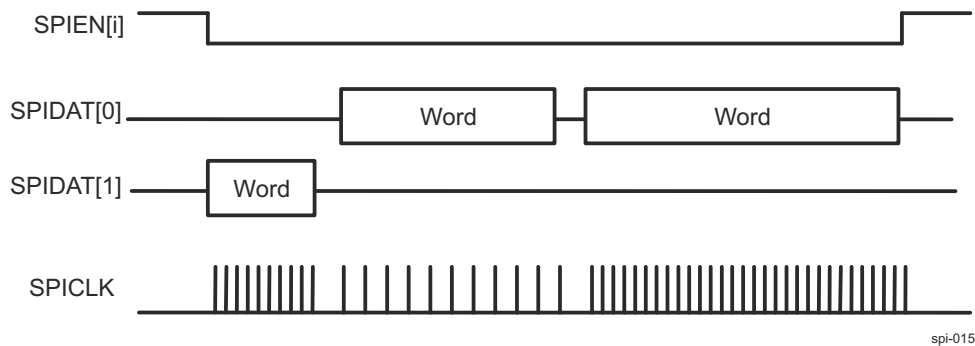

Figure 13-40. Continuous Transfers With SPIEN[i] Maintained Active (Dual-Data-Pin Interface Mode)

Note

The SPIEN[i] signal can be maintained active via software using the MCSPI_CHCONF_0/1/2/3[20] FORCE bit only when the MCSPI_MODULCTRL[0] SINGLE bit is set to 0x1.

13.1.3.4.3.5.3 Turbo Mode

Turbo mode improves the throughput of the MCSPI interface when a single channel is enabled by allowing transfers until the shift register and the MCSPI_RX_0/1/2/3 register are full. Turbo mode is time saving when a transfer exceeds two words. This mode is programmable per channel (through the MCSPI_CHCONF_0/1/2/3[9] TURBO bit).

When several channels are enabled, the TURBO bit has no effect and the channel access to the shift registers remains as previously described.

In turbo mode, Rule 1 and Rule 2 apply, but Rule 3 does not (see Section 13.1.3.4.3.2, *Controller Transmit-and-Receive Mode (Full Duplex)*). An enabled channel can be scheduled if its receive register is full (the MCSPI_CHSTAT_0/1/2/3[0] RXS bit) when the shift-register is assigned until the shift register is full.

The MCSPI_RX_0/1/2/3 register cannot be overwritten in turbo mode. Consequently, the MCSPI_IRQSTATUS[3] RX0_OVERFLOW bit is never set in this mode.

13.1.3.4.3.6 Start-Bit Mode

In start-bit mode, an extended bit is added before the MCSPI word to indicate whether the next MCSPI word must be handled as a command or as data. This feature is available only in controller mode. Start-bit mode cannot be used at the same time as turbo mode and/or force SPIEN[i] mode. In this case, only one channel can be used; round-robin arbitration is not possible.

This mode is programmable per channel by setting the MCSPI_CHCONF_0/1/2/3[23] SBE bit to 1. The polarity of the extended bit is programmable per channel. When the MCSPI_CHCONF_0/1/2/3[24] SBPOL bit is set to 0, the MCSPI word must be handled as a command. When the MCSPI_CHCONF_0/1/2/3[24] SBPOL bit is set to 1, the MCSPI word must be handled as data. Moreover, start-bit polarity can be changed dynamically during start-bit transfer without disabling the channel for reconfiguration; in this case, users must configure the MCSPI_CHCONF_0/1/2/3[24] SBPOL bit before writing the MCSPI word to be transmitted to the TX register.

13.1.3.4.3.7 Chip-Select Timing Control

The chip-select (CS) timing control is available only in controller mode with automatic CS generation (the MCSPI_MODULCTRL[0] SINGLE bit set to 0) to add a programmable delay between CS assertion and first clock edge, or CS removal and last clock edge. This option is available only in 4-pin mode when MCSPI_MODULCTRL[1] PIN34 set to 0.

This mode is programmable per channel through the MCSPI_CHCONF_0/1/2/3[26-25] TCS0 bit field.

Figure 13-41 shows the CS SPIEN timing controls.

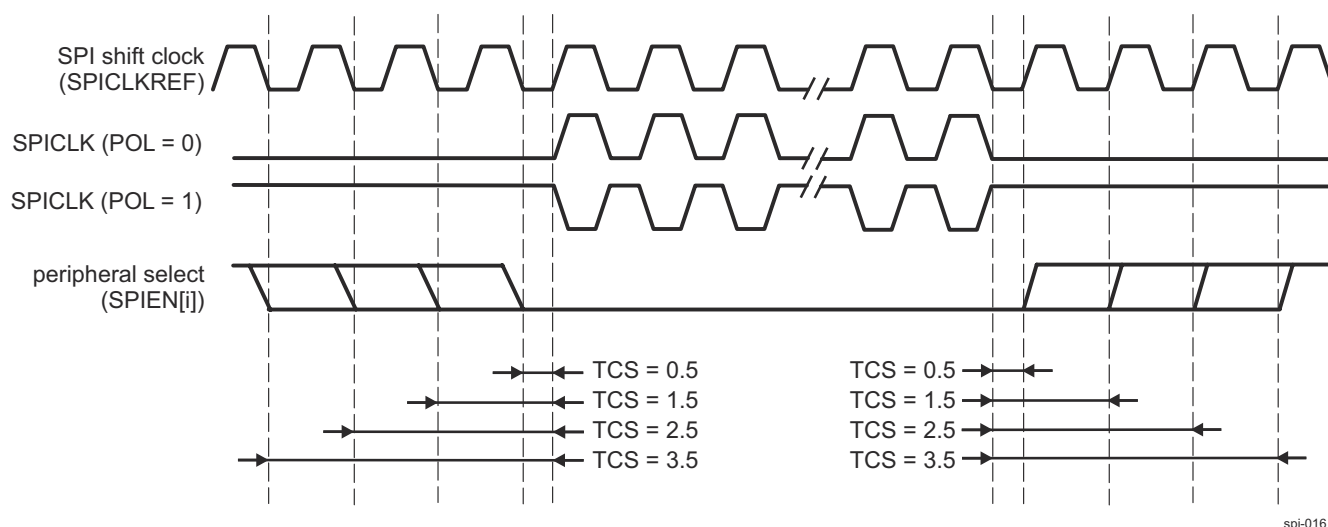

spi-016

Figure 13-41. CS SPIEN Timing Controls

Note

Because of the design implementation for transfers using a clock divider ratio set to 1 (clock bypassed), a half cycle must be added to the value between CS assertion and the first clock edge with PHA = 1 or between CS removal and the last clock edge with PHA = 0.

13.1.3.4.3.8 Programmable MCSPI Clock (SPICLK)

In controller mode, the baud rate of the MCSPI serial clock is programmable.

An internal reference clock, SPICLKREF, is used as input of a programmable divider (the MCSPI_CHCONF_0/1/2/3[5-2] CLKD bit field) to generate the bit rate of the serial output clock SPICLK. Table 13-28 summarizes the supported divisor values.

Table 13-28. MCSPI Controller Clock Rates

Divider	Clock Rate
1	50 MHz ⁽¹⁾
2	25 MHz ⁽¹⁾
4	12.5 MHz
8	6.25 MHz
16	3.125 MHz
32	1.5625 MHz
64	781.25 kHz
128	390 kHz ⁽²⁾
256	195 kHz ⁽²⁾
512	97.7 kHz ⁽²⁾
1024	48.8 kHz ⁽²⁾
2048	24.4 kHz ⁽²⁾
4096	12.2 kHz ⁽²⁾
8192 and higher:	Division not supported

- (1) These frequencies are not necessarily supported by all MCSPI modules. For more information, see the *Timing Requirements and Switching Characteristics* chapter in the device-specific Data sheet.
- (2) Approximate Frequency

13.1.3.4.3.8.1 Clock Ratio Granularity

By default, the clock division ratio is defined by the MCSPI_CHCONF_0/1/2/3[5-2] CLKD bit field with power-of-2 granularity leading to a clock division in the range 1 to 4096; in this case, the duty cycle is always 50 percent. With the MCSPI_CHCONF_0/1/2/3[29] CLKG bit, clock division granularity can be changed to one clock cycle; in that case the MCSPI_CHCTRL_0/1/2/3[15-8] EXTCLK bit field is concatenated with the MCSPI_CHCONF_0/1/2/3[5-2] CLKD bit field to give a 12-bit-wide division ratio in the range 1 to 4096.

When granularity is one clock cycle (the CLKG bit set to 1), for the odd value of the clock ratio, the clock high level lasts one clock cycle more than the low level, depending on the MCSPI_CHCONF_0/1/2/3[1] POL and MCSPI_CHCONF_0/1/2/3[0] PHA bits (see [Table 13-29](#)).

Table 13-29. CLKSPPIO High/Low Time Computation

Clock Ratio F_{RATIO}	CLKSPPIO High Time	CLKSPPIO Low Time
1	T_{HIGH_REF}	T_{LOW_REF}
Even ≥ 2	$T_{ref} * (F_{RATIO}/2)$	$T_{ref} * (F_{RATIO}/2)$
Odd $\geq (POL = PHA)$	$T_{ref} * (F_{RATIO} - 1)/2$	$T_{ref} * (F_{RATIO} + 1)/2$
Odd $\geq (POL \neq PHA)$	$T_{ref} * (F_{RATIO} + 1)/2$	$T_{ref} * (F_{RATIO} - 1)/2$

Note

F_{RATIO} = SPICLK frequency (F_{OUT}) division ratio
 T_{HIGH} = SPICLK high time period
 T_{LOW} = SPICLK low time period
 T_{ref} = MCSPI_FCLK period
 T_{HIGH_REF} = MCSPI_FCLK high time period
 T_{LOW_REF} = MCSPI_FCLK low time period

If the CLKG bit is set to 1; F_{RATIO} = EXTCLK concatenated with CLKD + 1.

For odd ratio values, the duty cycle is calculated as follows:

$$\text{Duty_cycle} = (1 - 1/F_{\text{RATIO}})/2$$

Table 13-30 shows examples of clock granularity with a clock source frequency of 50 MHz.

Table 13-30. Clock Granularity Examples

EXTCLK	CLKD	CLKG	F _{RATIO}	PHA	POL	T _{HIGH} (ns)	T _{LOW} (ns)	T _{PERIOD} (ns)	Duty Cycle	F _{OUT} (MHz)
X	0	0	1	X	X	10.0	10.0	20.0	50–50	50
X	1	0	2	X	X	20.0	20.0	40.0	50–50	25
X	2	0	4	X	X	40.0	40.0	80.0	50–50	12.5
X	3	0	8	X	X	80.0	80.0	160.0	50–50	6.2
0	0	1	1	X	X	10.0	10.0	20.0	50–50	50
0	1	1	2	X	X	20.0	20.0	40.0	50–50	25
0	2	1	3	1	0	40.0	20.0	60.0	66–33	16.6
0	2	1	3	1	1	20.0	40.0	60.0	33–66	16.6
0	3	1	4	X	X	40.0	40.0	80.0	50–50	12.5
5	0	1	81	1	0	820.0	800.0	1620.0	50.6–49.4	0.617
5	7	1	88	X	X	880.0	880.0	1760.0	50–50	0.568

13.1.3.4.4 MCSPI Peripheral Mode

To select the MCSPI peripheral mode, set the MCSPI_MODULCTRL[2] MS bit.

A MCSPI peripheral device can be connected to up to four external MCSPI controller devices but handles transactions with one MCSPI controller device at a time.

In peripheral mode, the MCSPI initiates data transfer on the data lines (SPIDAT[0] and SPIDAT[1]) when it is selected by an active control signal (SPIEN[i]) and receives an MCSPI clock (SPICLK) from the external MCSPI controller device. Only channel 0 can be configured as a peripheral but through the MCSPI_CHCONF_0[22-21] SPIENSLV bit field any of the SPIEN[i] signals can be used to select the MCSPI module. In peripheral mode and when the MCSPI_MODULCTRL[1] PIN34 is set to 0x0 (default behaviour), the MCSPI uses the edge of SPIEN[i] to detect word length. For this reason, SPIEN[i] must become inactive between each word.

When the MCSPI_MODULCTRL[1] PIN34 is set to 0x0, the MCSPI does not support SPIEN[i] active between MCSPI words. In this case, the MCSPI uses the edge to detect word length.

When the MCSPI_MODULCTRL[1] PIN34 is set to 0x1, a multiword transfer can be performed without needing the external MCSPI controller to deactivate SPIEN[i] between each word as in this case the MCSPI module works in 3-pin peripheral mode and SPIEN[i] is not needed.

13.1.3.4.4.1 Dedicated Resources

Only channel 0 can be enabled in peripheral mode.

Figure 13-42 shows an example of four peripherals wired on a single controller device.

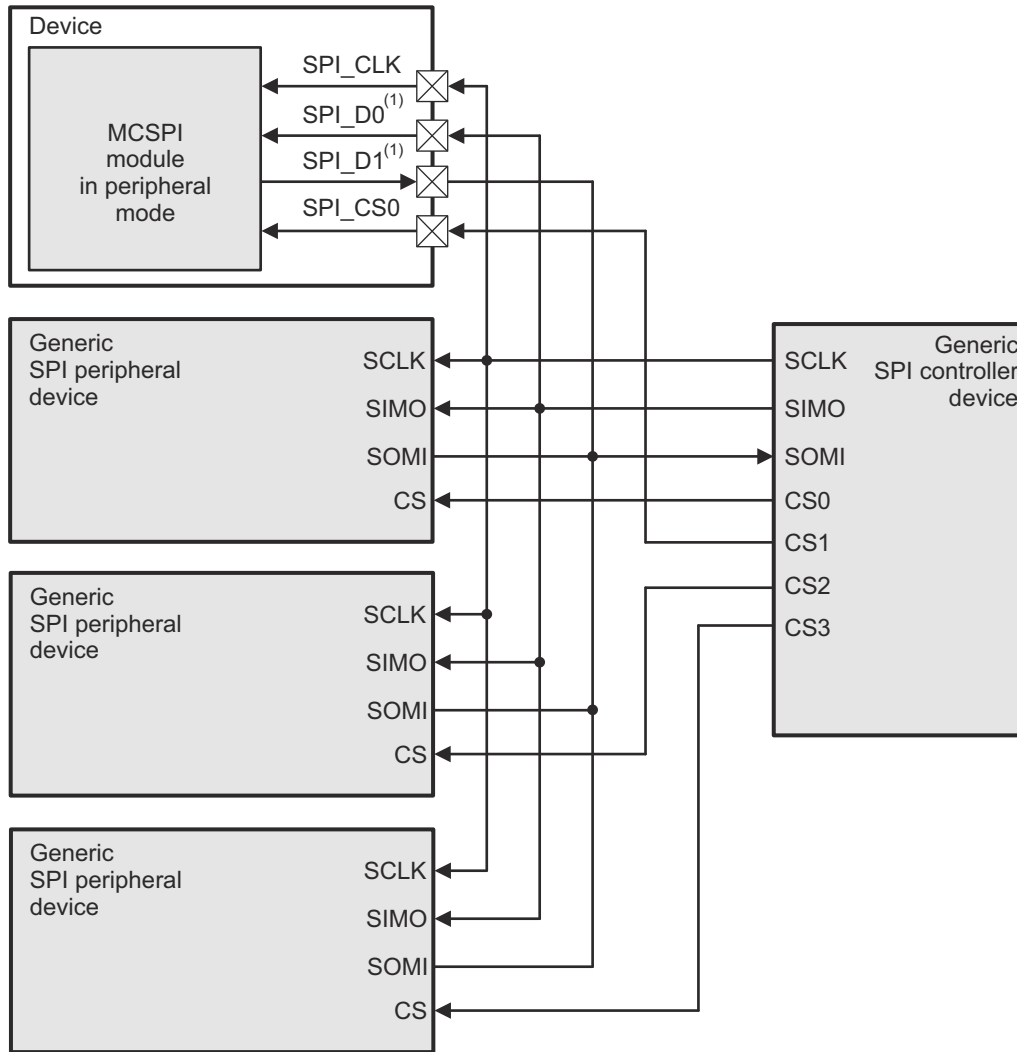

spi-017

- A. Direction depends on MCSPI_CHCONF_0/1/2/3[16] DPE0, MCSPI_CHCONF_0/1/2/3[17] DPE1 and MCSPI_CHCONF_0/1/2/3[18] IS bits

Figure 13-42. Example of MCSPI Peripheral With One Controller and Multiple Peripheral Devices on Channel 0

Channel 0 in peripheral mode has the following resources:

- Its own channel enable, programmable with the MCSPI_CHCTRL_0[0] EN bit. This channel must be enabled before transmission and reception.
- For this mode, the peripheral-select signal can be detected on any of the SPIEN[i] ports. This is programmable with the MCSPI_CHCONF_0[22-21] SPIENSLV bit field.
- Its own transmitter register, MCSPI_TX_0, on top of the common transmit shift register. If the MCSPI_TX_0 register is empty, the MCSPI_CHSTAT_0[1] TXS bit is set. If MCSPI is selected by an external controller (the active signal on the SPIEN[i] port assigned to channel 0), the MCSPI_TX_0 register content of channel 0 is always loaded into the shift register, whether its content is updated or not. The MCSPI_TX_0 register must be loaded before MCSPI is selected by a controller.
- Its own receiver register, MCSPI_RX_0, on top of the common receive shift register. If the MCSPI_RX_0 register is full, the MCSPI_CHSTAT_0[0] RXS bit is set.

ADVANCE INFORMATION

Note

The MCSPI_TX_1/2/3 and MCSPI_RX_1/2/3 registers are not used. Reading from or writing to a channel register other than channel 0 has no effect.

- Its own communication configuration with the following parameters through the MCSPI_CHCONF_0:
 - Transmit and receive modes, programmable with the TRM field
 - Interface mode (two data pins or single data pin) and data pins assignment, both programmable with the IS and DPE bits. (The MCSPI modules are in peripheral mode after reset and must be properly configured for the modules to act in controller mode.)
 - MCSPI word length, programmable with the WL bit
 - SPIEN[i] polarity, programmable with the EPOL bit
 - SPICLK polarity, programmable with the POL bit
 - SPICLK phase, programmable with the PHA bit

The SPICLK frequency of a transfer is controlled by the external MCSPI controller connected to the MCSPI peripheral device. The MCSPI_CHCONF_0[5-2] CLKD bit field is not used in peripheral mode.

Note

The configuration of the channel can be loaded in the MCSPI_CHCONF_0 only when the channel is disabled.

- Two DMA request events, read and write, synchronize read/write accesses of the DMA controller with the activity of MCSPI. DMA requests are asserted using the MCSPI_CHCONF_0[15] DMAR bit for reading and the MCSPI_CHCONF_0[14] DMAW bit for writing.
- Four interrupt events (see [Section 13.1.3.4.7.2, Interrupt Events in Peripheral Mode](#)).

13.1.3.4.4.2 Peripheral Transmit-and-Receive Mode

The peripheral receive mode is programmable (set the MCSPI_CHCONF_0[13-12] TRM bit field to 0x0).

In peripheral transmit-and-receive mode, the MCSPI_TX_0 register must be loaded before MCSPI is selected by an external MCSPI controller device.

After a channel is enabled, transmission and reception proceed with interrupt and DMA request events.

The MCSPI_TX_0 register content is always loaded in the shift register whether it is updated or not. The event TX0_UNDERFLOW is activated accordingly and does not prevent transmission.

When the MCSPI word transfer completes (the MCSPI_CHSTAT_0[2] EOT bit is set to 1), the received data is transferred to the channel receive register.

To use MCSPI as a peripheral transmit-only device, the RX0_FULL and RX0_OVERFLOW interrupts and DMA read requests must be disabled due to the state of the MCSPI_RX_0 register (see [Section 13.1.3.4.7.2, Interrupt Events in Peripheral Mode](#)).

13.1.3.4.4.3 Peripheral Transmit-Only Mode

The peripheral transmit-only mode is programmable (set the MCSPI_CHCONF_0[13-12] TRM bit field to 0x2) and avoids the requirement for the processor to read the MCSPI_RX_0 register (minimizing data movement) only when transmission is meaningful.

To use the MCSPI as a peripheral transmit-only device, the RX0_FULL and RX0_OVERFLOW interrupts and DMA read requests must be disabled due to the state of the MCSPI_RX_0 register.

When the MCSPI word transfer completes, the MCSPI_CHSTAT_0[2] EOT bit is set.

[Figure 13-43](#) shows a half-duplex system with a controller device on the left and a transmit-only peripheral device on the right. Each time a bit transfers out from the peripheral, 1 bit transfers in the controller. After eight cycles of the serial clock SPICLK, WordB transfers from the peripheral to the controller.

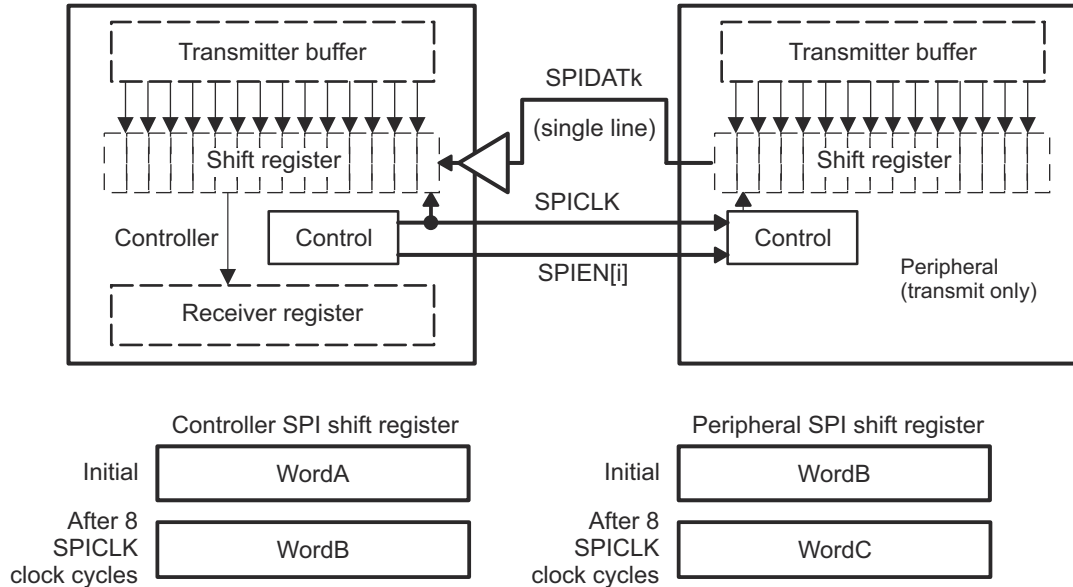

spi-018

k = 0 or 1 depending on MCSPI_CHCONF_0/1/2/3[16] DPE0, MCSPI_CHCONF_0/1/2/3[17] DPE1 and MCSPI_CHCONF_0/1/2/3[18] IS bits

Figure 13-43. MCSPI Half-Duplex Transmission (Transmit-Only peripheral)

13.1.3.4.4.4 Peripheral Receive-Only Mode

The peripheral receive mode is programmable (set the MCSPI_CHCONF_0[13-12] TRM bit field to 0x1).

In receive-only mode, the MCSPI_TX_0 register must be loaded before the MCSPI is selected by an external MCSPI controller device. The MCSPI_TX_0 register content is always loaded into the shift register whether it is updated or not. The TX0_UNDERFLOW event is activated accordingly and does not prevent transmission.

When the MCSPI word transfer completes (the MCSPI_CHSTAT_0[2] EOT bit is set to 1), the received data is transferred to the channel receive register.

To use the MCSPI as a peripheral receive-only device, the TX0_EMPTY and TX0_UNDERFLOW interrupts and the DMA write requests must be disabled due to the state of the MCSPI_TX_0 register.

For a full-duplex transmission, the serial clock (SPICLK) synchronizes shifting and sampling of the information on the single serial data line. For full duplex, two data lines are required. If SPICLK synchronizes on a single serial data line, the data line should be half-duplex.

Figure 13-44 shows a half-duplex system with a controller device on the left and a receive-only peripheral device on the right. Each time a bit transfers out from the controller, 1 bit transfers in from the peripheral. After eight cycles of the serial clock SPICLK, WordA transfers from the controller to the peripheral.

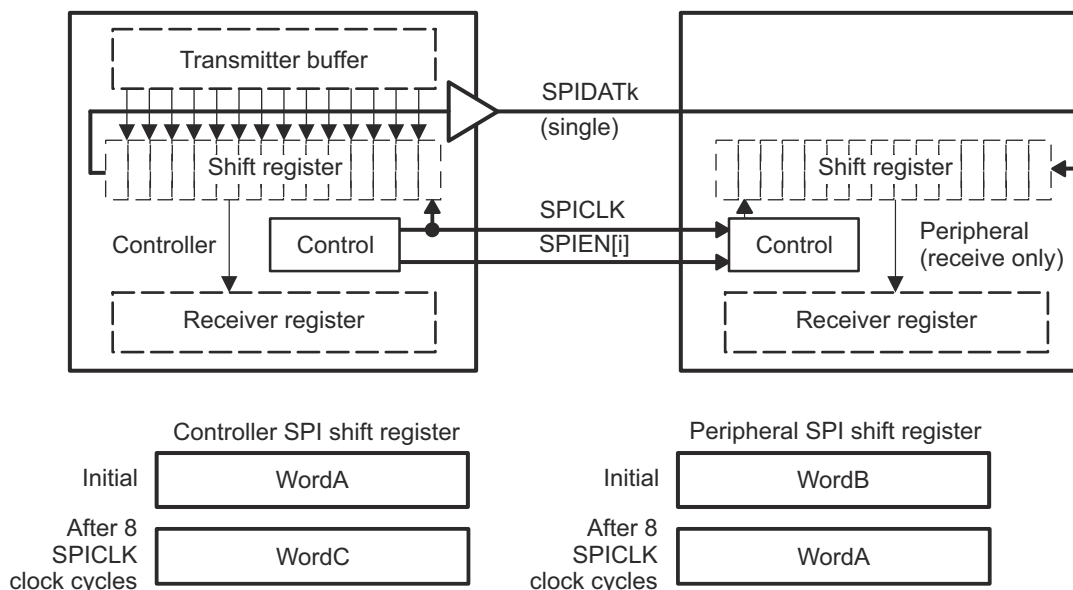

spi-019

k = 0 or 1 depending on MCSPI_CHCONF_0/1/2/3[16] DPE0, MCSPI_CHCONF_0/1/2/3[17] DPE1 and MCSPI_CHCONF_0/1/2/3[18] IS bits

Figure 13-44. MCSPI Half-Duplex Transmission (Receive-Only Peripheral)

13.1.3.4.5 MCSPI 3-Pin or 4-Pin Mode

Depending on targeted application the MCSPI interface can be configured to use 3 or 4 pins through the MCSPI_MODULCTRL[1] PIN34 bit. If this bit is set to 0, MCSPI is in 4-pin mode using the SPICLK, SPIDAT[0], SPIDAT[1] and SPIEN[i] signals. If PIN34 is set to 1 the controller is in 3-pin mode and SPIEN[i] is not used. In this mode all options related to chip select management are useless (EPOL, FORCE and TCS0 bits of MCSPI_CHCONF_0/1/2/3). 3-pin and 4-pin operation applies to both controller and peripheral modes.

13.1.3.4.6 MCSPI FIFO Buffer Management

The MCSPI controller has a built-in 64-byte buffer to unload the DMA or interrupt handler and improve data throughput.

This buffer can be used by only one channel at a time and is selected by setting the MCSPI_CHCONF_0/1/2/3[28] FFER or MCSPI_CHCONF_0/1/2/3[27] FFEW bit to 1. If several channels are selected and several FIFO enable bit fields are set to 1, the controller forces the buffer not to be used; the driver must set only one FIFO enable bit field.

The buffer can be used in the following modes:

- Controller or peripheral mode
- Transmit-only, receive-only, or transmit-and-receive mode
- Single channel or turbo mode, or normal round-robin mode. In round-robin mode the buffer is used by only one channel.

Every word length (MCSPI_CHCONF_0/1/2/3[11-7] WL) is supported.

In transmit-and-receive mode, the buffer can be used in transmit (see [Figure 13-45](#)) or receive (see [Figure 13-46](#)) directions, or in both directions. If only one direction is chosen in transmit-and-receive mode, the full buffer is used for this direction. In both directions, the buffer is split into two halves, one for each direction (see [Figure 13-47](#)).

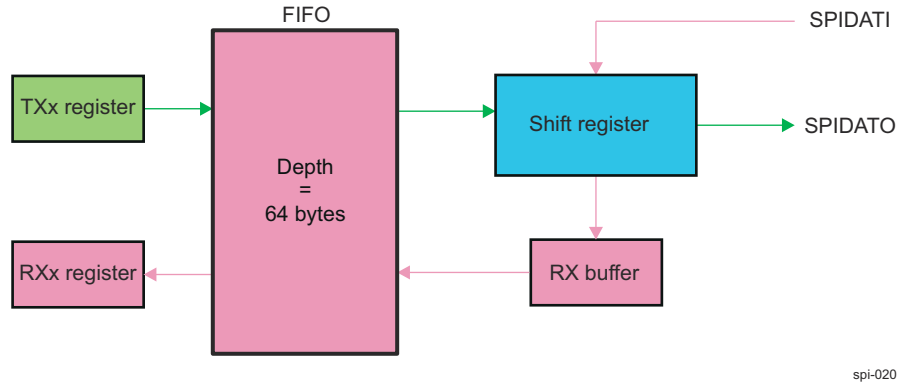

Figure 13-45. Buffer Used in Transmit Direction Only

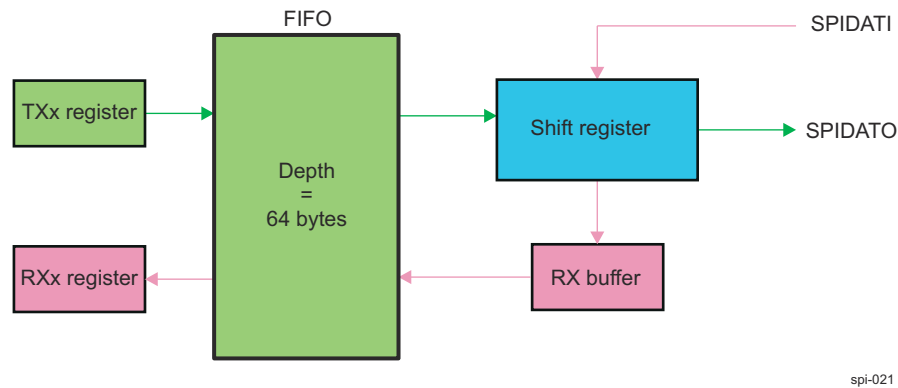

Figure 13-46. Buffer Used in Receive Direction Only

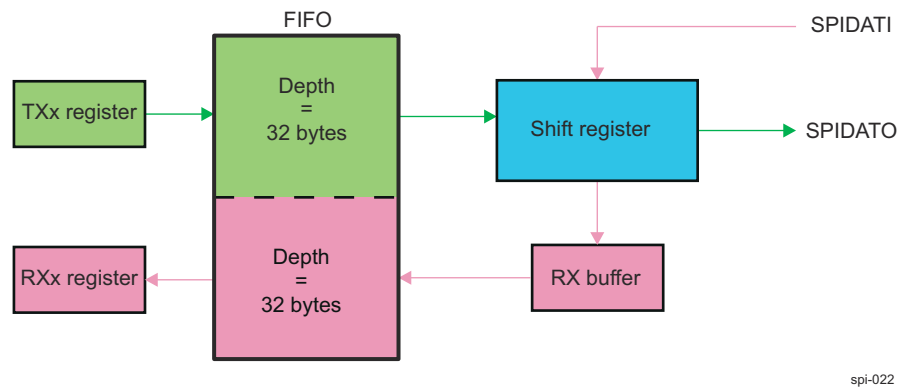

Figure 13-47. Buffer Used for Transmit and Receive Directions

Two levels (MCSPI_XFERLEVEL[5-0] AEL and MCSIPI_XFERLEVEL[13-8] AFL) rule the buffer management. The granularity of these levels is 1 byte; it is not aligned with the MCSPI word length. The driver must set these values as a multiple of the MCSPI word length defined in WL. Table 13-31 lists the number of bytes written in the FIFO, depending on the word length.

Table 13-31. FIFO Writes, Word Length Relationship

	MCSPI Word Length (WL)		
	3 ≤ WL ≤ 7	8 ≤ WL ≤ 15	16 ≤ WL ≤ 31
Number of bytes written in the FIFO	1 byte	2 bytes	4 bytes

The FIFO buffer pointers are reset when the corresponding channel is enabled or the FIFO configuration changes.

13.1.3.4.6.1 Buffer Almost Full

The MCSPI_XFERLEVEL[15-8] AFL bit field is needed when the buffer is used to receive an MCSPI word from a peripheral (the MCSPI_CHCONF_0/1/2/3[28] FFER bit must be set to 1). It defines the almost-full buffer status. See [Figure 13-48](#).

When the FIFO pointer reaches this level, an interrupt or a DMA request is sent to the processor to enable the system to read AFL + 1 bytes from the receive register.

Note

AFL + 1 must correspond to a multiple value of the MCSPI_CHCONF_0/1/2/3[11-7] WL bit field.

When DMA is used, the request is de-asserted after the first receive register read.

No new request is asserted again as long as the system has not performed the correct number of read accesses.

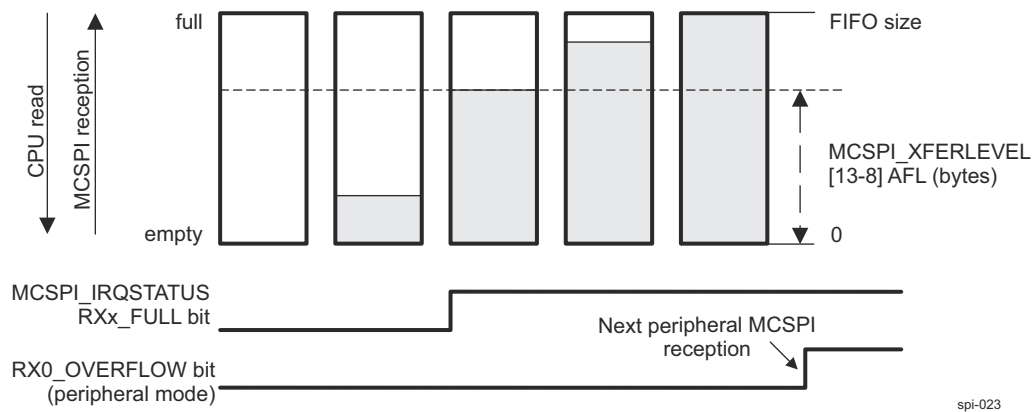

Figure 13-48. Buffer Almost Full Level (AFL)

Note

The MCSPI_IRQSTATUS register bits are not available in DMA mode. In DMA mode, the request is asserted on the same conditions as the MCSPI_IRQSTATUS RXx_FULL flag.

13.1.3.4.6.2 Buffer Almost Empty

The MCSPI_XFERLEVEL[7-0] AEL bit field is needed when the buffer is used to transmit an MCSPI word to a peripheral (the MCSPI_CHCONF_0/1/2/3[27] FFEW bit must be set to 1). It defines the almost-empty buffer status. See [Figure 13-49](#).

When the FIFO pointer does not reach this level, an interrupt or a DMA request is sent to the processor to enable the system to write AEL + 1 bytes to the transmit register.

Note

AEL + 1 must correspond to a multiple value of the MCSPI_CHCONF_0/1/2/3[11-7] WL bit field.

When DMA is used, the request is de-asserted after the first transmit register write.

No new request is asserted again as long as the system has not performed the correct number of write accesses.

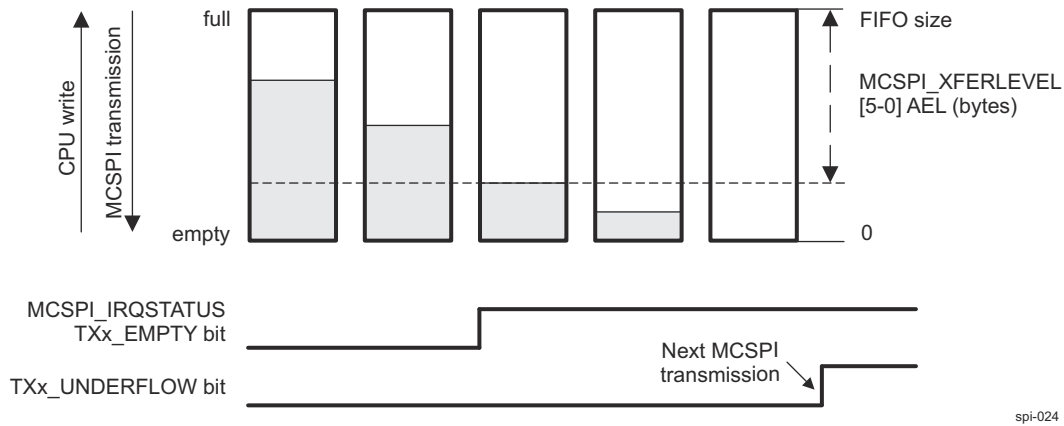

Figure 13-49. Buffer Almost Empty Level (AEL)

Note

The MCSPi_IRQSTATUS register bits are not available in DMA mode. In DMA mode, the request is asserted on the same conditions as the MCSPi_IRQSTATUS TXx_EMPTY flag.

13.1.3.4.6.3 End of Transfer Management

When the FIFO buffer is enabled for a channel, the user must previously configure in the MCSPi_XFERLEVEL register the AEL and AFL levels and especially the MCSPi_XFERLEVEL[31-16] WCNT bit field to define the number of MCSPi words to be transferred using the FIFO before enabling the channel.

This counter lets the controller stop the transfer correctly after a defined number of MCSPi word transfers. If WNCT is set to 0x0000, the counter is not used and the user must stop the transfer manually by disabling the channel; in this case, the user does not know how many MCSPi transfers have been done. For received words, software must poll the MCSPi_CHSTAT_i[5] RXFFE bit and read the MCSPi_RX_0/1/2/3 receive register to empty the FIFO buffer.

When the end-of-word count interrupt is generated (the MCSPi_IRQSTATUS[17] EOW bit is set), the user can disable the channel and poll the MCSPi_CHSTAT_0/1/2/3[5] RXFFE bit to know the last MCSPi words in the FIFO buffer and read them.

No new request is asserted as long as the system has not performed the correct number of write accesses.

13.1.3.4.6.4 Multiple MCSPi Word Access

The processor has the ability to perform multiple MCSPi word access to the receive or transmit registers within a single 32-bit interface access by setting the MCSPi_MODULCTRL[7] MOA to 1 under specific conditions:

- The channel selected has the FIFO enable.
- Only FIFO sense enabled support the kind of access.
- MCSPi_MODULCTRL[7] MOA is set to 1.
- Only 32-bit interface access and data width can be performed to receive or transmit registers, for other kind of access the processor must de-assert MCSPi_MODULCTRL[7] MOA bit.
- The level MCSPi_XFERLEVEL[7-0] AEL and MCSPi_XFERLEVEL[15-8] AFL must be 32-bit aligned, it means that AEL[0] = AEL[1] = 1 or AFL[0] = AFL[1] = 1.
- If MCSPi_XFERLEVEL[31-16] WCNT is used it must be configured according to MCSPi word length.
- The word length of MCSPi words allows to perform multiple MCSPi access, that means that MCSPi_CHCONF_0/1/2/3[11-7] WL is <16.

The number of MCSPi word access depends on MCSPi word length:

- $3 \leq WL \leq 7$, MCSPi word length smaller or equal to byte length, 4 MCSPi words accessed per 32-bit interface read/write. If word count is used (MCSPi_XFERLEVEL[31-16] WCNT), set the bit field to WCNT[0] = WCNT[1] = 0.

- $8 \leq WL \leq 15$, MCSPI word length greater than byte or equal to 16-bit length, 2 MCSPI words accessed per 32-bit interface read/write. If word count is used (MCSPI_XFERLEVEL[31-16] WCNT)), set the bit field to $WCNT[0] = 0$.
- $16 \leq WL$ Multiple MCSPI word access is not applicable.

13.1.3.4.6.5 First MCSPI Word Delay

Figure 13-50 shows the MCSPI controller ability to delay the first MCSPI word transfer to give time for system to complete some parallel processes or fill the FIFO in order to improve transfer bandwidth. This delay is applied only on first MCSPI word after MCSPI channel enabled and first write in transmit register. It is based on output clock frequency.

This option is meaningful in controller mode and single channel mode asserted through MCSPI_MODULCTRL[0] SINGLE.

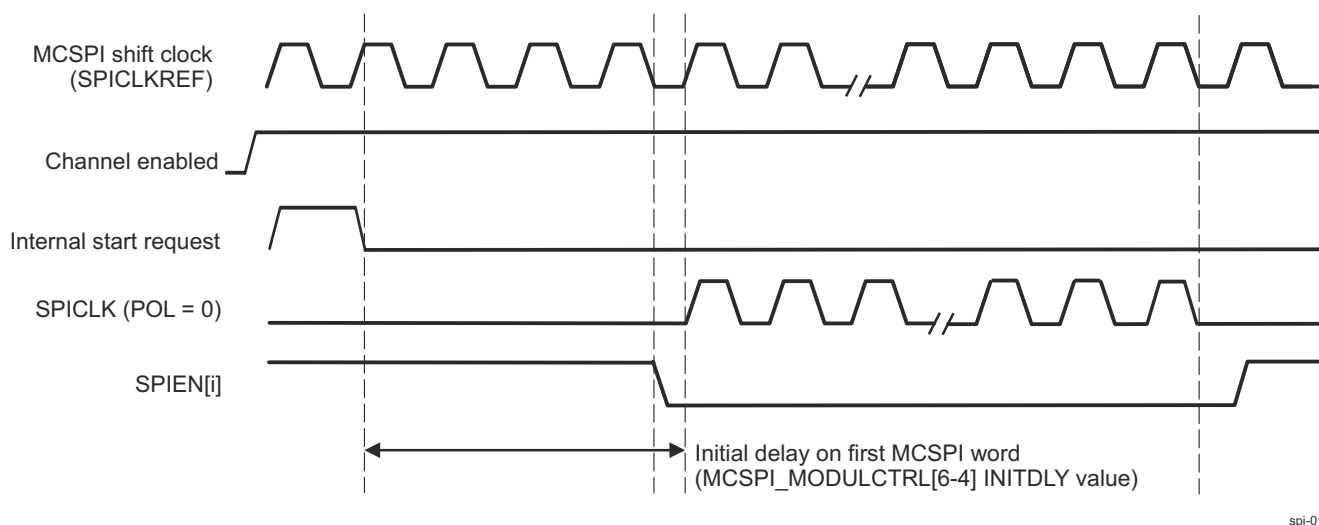

spi-016a

Figure 13-50. Controller Single Channel Initial Delay

Few delay values are available: No delay, 4/8/16/32 MCSPI cycles.

Its accuracy is half cycle in clock bypass mode and depends on clock polarity and phase.

13.1.3.4.7 MCSPI Interrupts

Each channel can issue interrupt events.

Each interrupt event has status bits in the MCSPI_IRQSTATUS register (RXx_FULL, TXx_UNDERFLOW, TXx_EMPTY, etc.) (where x = 0, 3) that indicate whether service is required. Each status bit has an interrupt enable bit (a mask) in the MCSPI_IRQENABLE register (RXx_FULL_ENABLE, TXx_UNDERFLOW_ENABLE, TXx_EMPTY_ENABLE, etc.).

When an interrupt occurs and a mask is later applied on it, the interrupt line is not asserted again, even if the interrupt source is not serviced.

The MCSPI supports interrupt-driven and polling operations.

13.1.3.4.7.1 Interrupt Events in Controller Mode

In controller mode, the interrupt events related to the state of the MCSPI_TX_0/1/2/3 register are TXx_EMPTY and TXx_UNDERFLOW. The interrupt event related to the state of the MCSPI_RX_0/1/2/3 register is RXx_FULL.

13.1.3.4.7.1.1 TXx_EMPTY

The TXx_EMPTY event is activated when a channel is enabled and its MCSPI_TX_0/1/2/3 register is empty (transient event). Enabling a channel automatically triggers this event, except in controller receive-

only mode (see [Section 13.1.3.4.3.4, Controller Receive-Only Mode](#)). When the FIFO buffer is enabled (the MCSPI_CHCONF_0/1/2/3[27] FFEW bit is set to 1), the MCSPI_IRQSTATUS TXx_EMPTY bit is set as soon as there is enough space in the buffer to write a number of bytes defined by the MCSPI_XFERLEVEL[5-0] AEL bit field.

The MCSPI_TX_0/1/2/3 register must be loaded with data to remove the source of the interrupt; the MCSPI_IRQSTATUS TXx_EMPTY interrupt status bit must be cleared for interrupt line deassertion (if the event is enabled as the interrupt source).

When FIFO is enabled, no new TXx_EMPTY event is asserted as long as the processor has not performed the number of writes into the MCSPI_TX_0/1/2/3 register defined by the MCSPI_XFERLEVEL[5-0] AEL bit field. The processor must perform the correct number of writes.

13.1.3.4.7.1.2 TXx_UNDERFLOW

The event TXx_UNDERFLOW is activated when the channel is enabled and if the MCSPI_TX_0/1/2/3 register or the FIFO is empty (not updated with new data) when an external controller device starts a data transfer with the MCSPI (transmit and receive).

The TXx_UNDERFLOW is a harmless warning in controller mode.

To avoid having a TXx_UNDERFLOW event at the beginning of a transmission, the TXx_UNDERFLOW event is not activated when no data has been loaded into the MCSPI_TX_0/1/2/3 register, because the channel is enabled. To avoid having a TXx_UNDERFLOW event, the MCSPI_TX_0/1/2/3 register must seldom be loaded.

The MCSPI_IRQSTATUS TXx_UNDERFLOW interrupt status bit must be cleared for interrupt line deassertion (if the event is enabled as the interrupt source).

13.1.3.4.7.1.3 RXx_FULL

The RXx_FULL event is activated when a channel is enabled and the MCSPI_RX_0/1/2/3 register becomes filled (transient event). When the FIFO buffer is enabled (the MCSPI_CHCONF_0/1/2/3[28] FFER bit is set to 1), RXx_FULL is asserted as soon as the number of bytes held in the FIFO to be read reaches the MCSPI_XFERLEVEL[13-8] AFL threshold.

The MCSPI_RX_0/1/2/3 register must be read to remove the source of the interrupt; the MCSPI_IRQSTATUS RXx_FULL interrupt status bit must be cleared for interrupt line deassertion (if the event is enabled as the interrupt source).

When FIFO is enabled, no new RXx_FULL event is asserted as long as the processor has not performed AFL + 1 reads into MCSPI_RX_0/1/2/3. The processor must perform the correct number of reads.

13.1.3.4.7.1.4 End Of Word Count

The MCSPI_IRQSTATUS[17] EOW event (end of word count) is activated when the channel is enabled and configured to use the built-in FIFO. This interrupt is raised when the controller performs the number of transfers defined in the MCSPI_XFERLEVEL[31-16] WCNT bit field. If WCNT is set to 0x0000, the counter is not enabled and this interrupt is not generated.

The end of word count interrupt also indicates that the MCSPI transfer is halted on the channel using the FIFO buffer as soon as MCSPI_XFERLEVEL[31-16] WCNT is not reloaded and the channel is not re-enabled.

The MCSPI_IRQSTATUS[17] EOW interrupt status bit must be cleared for interrupt line deassertion (if the event is enabled as the interrupt source).

13.1.3.4.7.2 Interrupt Events in Peripheral Mode

In peripheral mode, the interrupt events related to the state of the MCSPI_TX_0/1/2/3 register are TX0_EMPTY and TX0_UNDERFLOW. The interrupt events related to the state of the MCSPI_RX_0/1/2/3 are RX0_FULL and RX0_OVERFLOW (channels 1, 2, and 3 do not have a receiver overflow status bit). See the MCSPI_IRQSTATUS register.

13.1.3.4.7.2.1 TXx_EMPTY

The TXx_EMPTY event is activated when a channel is enabled and its MCSPI_TX_0/1/2/3 register is empty. Enabling the channel automatically raises this event. If the FIFO buffer is enabled (the MCSPI_CHCONF_0/1/2/3[27] FFEW bit is set to 1), the TXx_EMPTY event is asserted as soon as there is enough space in buffer to write a number of bytes defined by the MCSPI_XFERLEVEL[5-0] AEL bit field.

The MCSPI_TX_0/1/2/3 register must be loaded with data to remove the source of the interrupt; the MCSPI_IRQSTATUS TXx_EMPTY interrupt status bit must be cleared for interrupt line deassertion (if the event is enabled as the interrupt source).

When FIFO is enabled, no new TXx_EMPTY event is asserted as long as the processor has not performed the number of writes into the MCSPI_TX_0/1/2/3 register defined by MCSPI_XFERLEVEL[5-0] AEL bit field. The processor must perform the correct number of writes.

13.1.3.4.7.2.2 TXx_UNDERFLOW

The TXx_UNDERFLOW event is activated when a channel is enabled and if the MCSPI_TX_0/1/2/3 register is empty (not updated with new data) when an external controller device starts a data transfer with the MCSPI (transmit and receive).

When FIFO is enabled, the data emitted while the underflow event is raised is not the last data written in the FIFO but the next data in the FIFO (an old transmitted value or a dummy data in the FIFO has been reset).

TXx_UNDERFLOW indicates an error (data loss) in peripheral mode.

To avoid having a TXx_UNDERFLOW event at the beginning of a transmission, the TXx_UNDERFLOW event is not activated when no data has been loaded into the MCSPI_TX_0/1/2/3 register because the channel is enabled.

The MCSPI_IRQSTATUS TXx_UNDERFLOW interrupt status bit must be cleared for interrupt line deassertion (if the event is enabled as the interrupt source).

13.1.3.4.7.2.3 RXx_FULL

The RXx_FULL event is activated when a channel is enabled and the MCSPI_RX_0/1/2/3 register is being filled (transient event). When the FIFO buffer is enabled (the MCSPI_CHCONF_0/1/2/3[28] FFER bit is set to 1), RXx_FULL is asserted as soon as the number of bytes held in the buffer to read defined by the MCSPI_XFERLEVEL[13-8] AFL bit field.

The MCSPI_RX_0/1/2/3 register must be read to remove the source of the interrupt; the MCSPI_IRQSTATUS RXx_FULL interrupt status bit must be cleared for interrupt line deassertion (if the event is enabled as the interrupt source).

When FIFO is enabled, no new RXx_FULL event is asserted as long as the processor has not performed AFL + 1 reads into MCSPI_RX_0/1/2/3. The processor must perform the correct number of reads.

13.1.3.4.7.2.4 RX0_OVERFLOW

The RX0_OVERFLOW event is activated in peripheral mode in transmit-and-receive mode or receive-only mode when a channel is enabled and the MCSPI_RX_0/1/2/3 register or FIFO is full when a new MCSPI word is received. The MCSPI_RX_0/1/2/3 register is always overwritten with the new MCSPI word. If the FIFO is enabled, data within the FIFO are overwritten; it must be considered as corrupted. The RX0_OVERFLOW event should not appear in peripheral mode using the FIFO.

The RX0_OVERFLOW event indicates an error (data loss) in peripheral mode.

The MCSPI_IRQSTATUS[3] RX0_OVERFLOW interrupt status bit must be cleared for interrupt line deassertion (if the event is enabled as the interrupt source).

13.1.3.4.7.2.5 End Of Word Count

The MCSPI_IRQSTATUS[17] EOW event (end of word count) is activated when the channel is enabled and configured to use the built-in FIFO. This interrupt is raised when the controller performs the number of transfers

defined in the MCSPI_XFERLEVEL[31-16] WCNT bit field. If WCNT is set to 0x0000, the counter is not enabled and this interrupt is not generated.

The end of word count interrupt also indicates that the MCSPI transfer is halted on the channel using the FIFO buffer as soon as WCNT is not reloaded and the channel is not re-enabled.

The MCSPI_IRQSTATUS[17] EOW interrupt status bit must be cleared for interrupt line deassertion (if the event is enabled as the interrupt source).

13.1.3.4.7.3 Interrupt-Driven Operation

An interrupt enable bit in the MCSPI_IRQENABLE register can be set to enable each event to generate interrupt requests when the corresponding event occurs. Status bits are automatically set by hardware logic conditions.

When an event occurs (the single interrupt line is asserted), the processor must:

1. Read the MCSPI_IRQSTATUS register to identify which event occurred.
2. Read the MCSPI_RX_0/1/2/3 register that corresponds to the event to remove the source of an RXx_FULL event or write into the MCSPI_TX_0/1/2/3 register that corresponds to the event to remove the source of a TXx_EMPTY event. No action is required to remove the source of the TXx_UNDERFLOW and RX0_OVERFLOW events.
3. Set the corresponding bit of the MCSPI_IRQSTATUS register to 1 to clear an interrupt status and then release the interrupt line.

The interrupt status bit must always be reset after channel enabling and before events are enabled as interrupt sources.

13.1.3.4.7.4 Polling

When the interrupt capability of an event is disabled in the MCSPI_IRQENABLE register, the interrupt line is not asserted, but the status bits in the MCSPI_IRQSTATUS register can be polled by software to detect when the corresponding event occurs.

Once the expected event occurs:

- RXx_FULL: To remove the source of the event, the processor must read the corresponding MCSPI_RX_0/1/2/3 register.
- TXx_EMPTY: To remove the source of the event, the processor must write into the corresponding MCSPI_TX_0/1/2/3 register.
- TXx_UNDERFLOW and RX0_OVERFLOW: No action is required to remove the source of the event.

To clear an interrupt, set the corresponding status bit of the MCSPI_IRQSTATUS register to 1. This does not affect the interrupt line state.

13.1.3.4.8 MCSPI DMA Requests

Each MCSPI channel, if enabled, can issue DMA requests. There are two DMA request lines per MCSPI channel (one for read and one for write).

The DMA read request line is asserted when the MCSPI channel is enabled and new data is available in the receive register of the MCSPI channel. A DMA read request can be individually masked with the MCSPI_CHCONF_0/1/2/3[15] DMAR bit. The DMA read request line is de-asserted when reading of the MCSPI_RX_0/1/2/3 register of the MCSPI channel completes.

The DMA write request line is asserted when the MCSPI channel is enabled and the MCSPI_TX_0/1/2/3 register of the MCSPI channel is empty. A DMA write request can be individually masked with the MCSPI_CHCONF_0/1/2/3[14] DMAW bit. The DMA write request line is de-asserted when loading of the MCSPI_TX_0/1/2/3 register of the channel completes.

13.1.3.4.9 MCSPI Power Saving Management

Power consumption can be optimized by switching off internal clocks (interface and functional clock) when there is no activity.

13.1.3.4.9.1 Normal Mode

In normal mode, internal MCSPI module clocks are automatically switched off (autogated) when there is no activity in peripheral or controller mode.

Autogating of the module interface clock and functional clock occurs when the following conditions are met:

- The MCSPI_SYSCONFIG[0] AUTOIDLE bit is set.
- In controller mode, there is no data to transmit or receive in all channels.
- In peripheral mode, the MCSPI is not selected by the external controller and there are no register accesses.

Autogating of the module interface clock and functional clock stops when the following conditions are met:

- In controller mode, an internal access occurs.
- In peripheral mode, an internal access occurs or the MCSPI is selected by the external controller.

13.1.3.4.9.2 Idle Mode

Note

Some of the MCSPI features described in this section may not be supported on this family of devices. For more information, see , *MCSPI Not Supported Features*.

At the power management level, when all conditions to shut off the MCSPI_FCLK or MCSPI_ICLK clocks are met, the corresponding LPSC asserts a clock stop request to the MCSPI. Although this procedure is completely hardware-oriented and out of software control, the method in which the MCSPI module acknowledges the clock stop request can be configured through the MCSPI_SYSCONFIG[4-3] SIDLEMODE bit field.

The settings of the SIDLEMODE bit field and the related acknowledgement modes are:

- Force-idle mode (the MCSPI_SYSCONFIG[4-3] SIDLEMODE bit field is set to 0x0): The MCSPI module acknowledges unconditionally the clock stop request, regardless of its internal operations. This mode must be used carefully in this case because it does not prevent the loss of data when the clock is switched off.
- No-idle mode (the SIDLEMODE bit field is set to 0x1): The MCSPI never acknowledges the clock stop request and is safe from a module point of view because it ensures that the clocks remain active. However, it is not efficient to save power because it does not allow shut off of MCSPI_FCLK and MCSPI_ICLK.
- Smart-idle mode (the SIDLEMODE bit field is set to 0x2): The MCSPI acknowledges the clock stop request, depending on its internal activity. MCSPI acknowledges the shut off of MCSPI_FCLK and MCSPI_ICLK only when all pending transactions, IRQs, or DMA requests are treated. This is the best approach for efficient system power management.

When configured in smart-idle mode, the MCSPI also offers an additional feature to control gating of MCSPI_FCLK or MCSPI_ICLK. The MCSPI_SYSCONFIG[9-8] CLOCKACTIVITY bit field determines which clock shuts down (MCSPI_FCLK, MCSPI_ICLK, neither clock, or both clocks).

The setting of the CLOCKACTIVITY bit field is used internally to the MCSPI to determine on which part of the module the conditions to acknowledge the clock stop request are tested. For example, if MCSPI_FCLK is not shut off on clock stop request, the MCSPI considers only MCSPI_ICLK and the associated pending activities before acknowledging the request.

Some MCSPI features are associated with MCSPI_ICLK and others with MCSPI_FCLK. Using the CLOCKACTIVITY bit field with the smart-idle mode ensures that the features associated with the clock that remains active are always enabled, even if MCSPI acknowledges the clock stop request.

13.1.3.4.9.2.1 Force-Idle Mode

Force-idle mode is enabled and exited as follows:

- Force-idle mode is enabled when the MCSPI_SYSCONFIG[4-3] SIDLEMODE bit field is set to 0x0.
 - In force-idle mode, the MCSPI responds unconditionally to the clock stop request by de-asserting unconditionally the interrupt and DMA request lines, if asserted.

- The transition from normal mode to idle mode does not affect the interrupt event bits of the MCSPI_IRQSTATUS register.
- In force-idle mode, because the module must be disabled, the interrupt and DMA request lines are likely de-asserted. The interface clock and MCSPI clock provided to the MCSPI can be switched off.
- A clock stop request during an MCSPI data transfer can lead to an unexpected and unpredictable result. Software must avoid such a request.

13.1.3.5 MCSPI Programming Guide

This section describes the low-level hardware programming sequences for the configuration and use of the MCSPI module.

13.1.3.5.1 MCSPI Global Initialization

13.1.3.5.1.1 MCSPI Global Initialization

13.1.3.5.1.1.1 Main Sequence – MCSPI Global Initialization

The procedure in [Table 13-32](#) can be used to initialize MCSPI when performing software reset.

Table 13-32. MCSPI Global Initialization

Step	Register/Bit Field/Programming Model	Value
Perform a software reset.	MCSPY_SYSCONFIG[1] SOFTRESET	1
Wait until reset is finished?	MCSPY_SYSSTATUS[0] RESETDONE	=1
Configure static settings (such as SPI controller or peripheral) as required.	MCSPY_MODULCTRL[8-0]	0x-
Write MCSPY_SYSCONFIG	MCSPY_SYSCONFIG	0x-

13.1.3.5.2 MCSPI Operational Mode Configuration

13.1.3.5.2.1 MCSPI Operational Modes

The selection of the working mode is done with the MCSPY_CHCONF_0/1/2/3 register.

Table 13-33. MCSPI Receive Mode Initialization

Step	Register/Bit Field/Programming Model	Value
Set receive mode for the channel.	MCSPY_CHCONF_0/1/2/3[13-12] TRM	0x1
Configure SPI clock polarity/phase, clock divider, word length, and others for the channel.	MCSPY_CHCONF_0/1/2/3	0x-
Reset the status bits.	MCSPY_IRQSTATUS	0x0

Table 13-34. MCSPI Transmit Mode Initialization

Step	Register/Bit Field/Programming Model	Value
Set transmit mode for the channel.	MCSPY_CHCONF_0/1/2/3[13-12] TRM	0x2
Configure SPI clock polarity/phase, clock divider, word length, and others for the channel.	MCSPY_CHCONF_0/1/2/3	0x-
Reset the status bits.	MCSPY_IRQSTATUS	0x0

Table 13-35. MCSPI Transmit-and-Receive Mode Initialization

Step	Register/Bit Field/Programming Model	Value
Set transmit and receive mode for the channel.	MCSPY_CHCONF_0/1/2/3[13-12] TRM	0x0
Configure SPI clock polarity/phase, clock divider, word length, and others for the channel.	MCSPY_CHCONF_0/1/2/3	0x-
Reset the status bits.	MCSPY_IRQSTATUS	0x0

13.1.3.5.2.1.1 Common Transfer Sequence

MCSPI module allows the transfer of one or several words, according to different modes:

- CONTROLLER Normal, CONTROLLER Turbo, PERIPHERAL
- TRANSMIT-RECEIVE, TRANSMIT-ONLY, RECEIVE-ONLY
- Write and Read requests: Interrupts, DMA
- SPIEN[i] lines assertion/deassertion: automatic, manual

For all these sequences, the host process contains the main process and the interrupt routines.

The interrupt routines are called on the interrupt signals or by an internal call if the module is used in polling mode.

Table 13-36 represents the main sequence which is common to all transfers.

In multi-channel controller mode, the sequences of different channels can be run simultaneously.

Table 13-36. Common Transfer Sequence (Main Process)

Step	Register/Bit Field/Programming Model	Value
Write MCSPI_IRQSTATUS to reset channel status bits	MCSPI_IRQSTATUS[channel i bits]	0b1111
Write MCSPI_IRQENABLE to enable interrupts	MCSPI_IRQENABLE	0x-
Write MCSPI_CHCONF_0/1/2/3 to configure the channel	MCSPI_CHCONF_0/1/2/3	0x-
Start the channel	MCSPI_CHCTRL_0/1/2/3[0] EN	1
Wait for the first write request (TX empty or DMA write)		
Write the transmitter register with data	MCSPI_TX_0/1/2/3	0x-
Wait for the host event for end of transfer		
Stop the channel	MCSPI_CHCTRL_0/1/2/3[0] EN	0

13.1.3.5.2.1.2 End of Transfer Sequences

The end of transfer depends on the transfer mode. Table 13-37 summarizes the type of end of transfer per transfer mode and gives a reference to the appropriate section for details.

Table 13-37. End of Transfer Sequences

		TRANSMIT-AND-RECEIVE		TRANSMIT-ONLY		RECEIVE-ONLY	
		INTERRUPT	DMA	INTERRUPT	DMA	INTERRUPT	DMA
CONTROL LER Normal	End of transfer sequence	See Section 13.1.3.5.2.1.3		See Section 13.1.3.5.2.1.4.1	See Section 13.1.3.5.2.1.4.2	See Section 13.1.3.5.2.1.5.1	See Section 13.1.3.5.2.1.5.2
	Minimum number of word	1	1	1	1	1	2
	DMA transfer size		N		N		N-1
CONTROL LER Turbo	End of transfer sequence	See Section 13.1.3.5.2.1.3		See Section 13.1.3.5.2.1.4.1	See Section 13.1.3.5.2.1.4.2	See Section 13.1.3.5.2.1.6.1	See Section 13.1.3.5.2.1.6.2
	Minimum number of word	1	1	1	1	2	3
	DMA transfer size		N		N		N-2
PERIPHER AL	End of transfer sequence	See Section 13.1.3.5.2.1.3		See Section 13.1.3.5.2.1.4.1	See Section 13.1.3.5.2.1.4.2	See Section 13.1.3.5.2.1.7	
	Minimum number of word	1	1	1	1	1	1
	DMA transfer size		N		N	N	N

The transfer to execute has a size of N words.

The different sequences can be merged in one process to manage transfers of several types. The end of transfer sequences are described from the start of the channel.

In these sequences, some soft variables are used:

- write_count = 0
- read_count = 0
- channel_enable = FALSE
- last_transfer = FALSE
- last_request = FALSE

They are initialized before starting the channel.

13.1.3.5.2.1.3 Transmit-and-Receive (Controller and Peripheral)

If the requests are configured in DMA, write_count and read_count are assigned with 'N' when the DMA handlers have completed their 'N' CBASS0 accesses.

Table 13-38. Transmit-and-Receive (Controller and Peripheral) (Main Process)

Step	Register/Bit Field/Programming Model	Value
Start the channel	MCSPi_CHCTRL_0/1/2/3[0] EN	1
Wait for write_count = N AND read_count = N		
Stop the channel	MCSPi_CHCTRL_0/1/2/3[0] EN	0

Table 13-39. Transmit-and-Receive (Controller and Peripheral) (Interrupt Routine)

Step	Register/Bit Field/Programming Model	Value
Read MCSPi_IRQSTATUS	MCSPi_IRQSTATUS	0x-
Write MCSPi_IRQSTATUS to reset channel status bits	MCSPi_IRQSTATUS[channel i bits]	0b1111
IF: TXx_EMPTY		
Write the transmitter register with data	MCSPi_TX_0/1/2/3	0x-
Increment write_count +1		
IF: RXx_FULL		
Read the receiver register	MCSPi_RX_0/1/2/3	
Increment read_count +1		
ENDIF		

13.1.3.5.2.1.4 Transmit-Only (Controller and Peripheral)

13.1.3.5.2.1.4.1 Based on Interrupt Requests

Table 13-40. Transmit-Only With Interrupts (Controller and Peripheral) (Main Process)

Step	Register/Bit Field/Programming Model	Value
Start the channel	MCSPi_CHCTRL_0/1/2/3[0] EN	1
Wait until last_transfer = TRUE		
Wait for end of transfer	MCSPi_CHSTAT_0/1/2/3[2] EOT	=1
Stop the channel	MCSPi_CHCTRL_0/1/2/3[0] EN	0

Table 13-41. Transmit-Only With Interrupts (Controller and Peripheral) (Interrupt Routine)

Step	Register/Bit Field/Programming Model	Value
Read MCSPi_IRQSTATUS	MCSPi_IRQSTATUS	0x-
Write MCSPi_IRQSTATUS to reset channel status bits	MCSPi_IRQSTATUS[channel i bits]	0b1111
IF: TXx_EMPTY AND write_count < N		
Write the transmitter register with data	MCSPi_TX_0/1/2/3	0x-
Increment write_count +1		
ELSEIF: write_count ≥ N		
last_transfer = TRUE		
ENDIF		

13.1.3.5.2.1.4.2 Based on DMA Write Requests

When the DMA handler has completed its 'N' CBASS0 accesses, write_count is assigned with 'N'.

Table 13-42. Transmit-Only With DMA (Controller and Peripheral) (Main Process)

Step	Register/Bit Field/Programming Model	Value
Start the channel	MCSPi_CHCTRL_0/1/2/3[0] EN	1
Wait until write_count = N		

Table 13-42. Transmit-Only With DMA (Controller and Peripheral) (Main Process) (continued)

Step	Register/Bit Field/Programming Model	Value
Disable DMA write request	MCSPi_CHCONF_0/1/2/3[14] DMAW	0
Wait until last_transfer = TRUE		
Wait for end of transfer	MCSPi_CHSTAT_0/1/2/3[2] EOT	=1
Stop the channel	MCSPi_CHCTRL_0/1/2/3[0] EN	0

Table 13-43. Transmit-Only With DMA (Controller and Peripheral) (Interrupt Routine)

Step	Register/Bit Field/Programming Model	Value
Read MCSPi_IRQSTATUS	MCSPi_IRQSTATUS	0x-
Write MCSPi_IRQSTATUS to reset channel status bits	MCSPi_IRQSTATUS[channel i bits]	0b1111
IF: TXx_EMPTY AND write_count = N		
last_transfer = TRUE		
ENDIF		

13.1.3.5.2.1.5 Controller Normal Receive-Only

13.1.3.5.2.1.5.1 Based on Interrupt Requests

Table 13-44. Receive-Only With Interrupt (Controller Normal) (Main Process)

Step	Register/Bit Field/Programming Model	Value
Start the channel	MCSPi_CHCTRL_0/1/2/3[0] EN	1
Wait until last_request = TRUE		
Stop the channel	MCSPi_CHCTRL_0/1/2/3[0] EN	0
Read the receiver register	MCSPi_RX_0/1/2/3	0x-
Increment read_count +1		

Table 13-45. Receive-Only With Interrupt (Controller Normal) (Interrupt Routine)

Step	Register/Bit Field/Programming Model	Value
Read MCSPi_IRQSTATUS	MCSPi_IRQSTATUS	0x-
Write MCSPi_IRQSTATUS to reset channel status bits	MCSPi_IRQSTATUS[channel i bits]	0b1111
IF: RXx_FULL AND read_count = N - 1		
last_request = TRUE		
ELSEIF: read_count ≠ N - 1		
Read the receiver register	MCSPi_RX_0/1/2/3	0x-
Increment read_count +1		
ENDIF		

13.1.3.5.2.1.5.2 Based on DMA Read Requests

When the DMA handler has completed its 'N-1' CBASS0 accesses, read_count is assigned with 'N-1'.

Table 13-46. Receive-Only With DMA (Controller Normal) (Main Process)

Step	Register/Bit Field/Programming Model	Value
Start the channel	MCSPi_CHCTRL_0/1/2/3[0] EN	1
Wait until read_count = N - 1		
Disable DMA read request	MCSPi_CHCONF_0/1/2/3[15] DMAR	0
Wait until last_transfer = TRUE		
Stop the channel	MCSPi_CHCTRL_0/1/2/3[0] EN	0
Read the receiver register	MCSPi_RX_0/1/2/3	0x-
Increment read_count +1		

Table 13-47. Receive-Only With DMA (Controller Normal) (Interrupt Routine)

Step	Register/Bit Field/Programming Model	Value
Read MCSPI_IRQSTATUS	MCSPI_IRQSTATUS	0x-
Write MCSPI_IRQSTATUS to reset channel status bits	MCSPI_IRQSTATUS[channel i bits]	0b1111
IF: RXx_FULL AND read_count = N		
last_transfer = TRUE		
ENDIF		

13.1.3.5.2.1.6 Controller Turbo Receive-Only**13.1.3.5.2.1.6.1 Based on Interrupt Requests****Table 13-48. Receive-Only With Interrupt (Controller Turbo) (Main Process)**

Step	Register/Bit Field/Programming Model	Value
Start the channel	MCSPI_CHCTRL_0/1/2/3[0] EN	1
Wait until channel_enable = TRUE		
Wait until last_transfer = TRUE		
Wait for end of transfer	MCSPI_CHSTAT_0/1/2/3[2] EOT	=1
Stop the channel	MCSPI_CHCTRL_0/1/2/3[0] EN	0
Wait until channel_enable = FALSE		

Table 13-49. Receive-Only With Interrupt (Controller Turbo) (Interrupt Routine)

Step	Register/Bit Field/Programming Model	Value
Read MCSPI_IRQSTATUS	MCSPI_IRQSTATUS	0x-
Write MCSPI_IRQSTATUS to reset channel status bits	MCSPI_IRQSTATUS[channel i bits]	0b1111
IF: RXx_FULL		
IF: read_count = N - 2		
last_transfer = TRUE		
Wait until channel_enable = FALSE		
ENDIF		
IF: read_count < N		
Read the receiver register	MCSPI_RX_0/1/2/3	0x-
Increment read_count +1		
ENDIF		
ENDIF		

13.1.3.5.2.1.6.2 Based on DMA Read Requests

When the DMA handler has completed its 'N-2' CBASS0 accesses read_count is assigned with 'N-2'.

Table 13-50. Receive-Only With DMA (Controller Turbo) (Main Process)

Step	Register/Bit Field/Programming Model	Value
Start the channel	MCSPI_CHCTRL_0/1/2/3[0] EN	1
Wait until channel_enable = TRUE		
Wait until read_count = TRUE		
Disable DMA read request	MCSPI_CHCONF_0/1/2/3[15] DMAR	0
Wait until last_transfer = TRUE		
Wait for end of transfer	MCSPI_CHSTAT_0/1/2/3[2] EOT	=1
Stop the channel	MCSPI_CHCTRL_0/1/2/3[0] EN	0
Wait until channel_enable = FALSE		

Table 13-51. Receive-Only With DMA (Controller Turbo) (Interrupt Routine)

Step	Register/Bit Field/Programming Model	Value
Read MCSPI_IRQSTATUS	MCSPI_IRQSTATUS	0x-
Write MCSPI_IRQSTATUS to reset channel status bits	MCSPI_IRQSTATUS[channel i bits]	0b1111
IF: RXx_FULL		
IF: read_count = N - 2		
last_transfer = TRUE		
Wait until channel_enable = FALSE		
ENDIF		
IF: read_count < N		
Read the receiver register	MCSPI_RX_0/1/2/3	0x-
Increment read_count +1		
ENDIF		
ENDIF		

13.1.3.5.2.1.7 Peripheral Receive-Only

If the requests are configured in DMA, read_count is assigned with 'N' when the DMA handler has completed its 'N' CBASS0 accesses.

Table 13-52. Receive-Only (Peripheral) (Main Process)

Step	Register/Bit Field/Programming Model	Value
Start the channel	MCSPI_CHCTRL_0/1/2/3[0] EN	1
Wait until read_count = N		
Stop the channel	MCSPI_CHCTRL_0/1/2/3[0] EN	0

Table 13-53. Receive-Only (Peripheral) (Interrupt Routine)

Step	Register/Bit Field/Programming Model	Value
Read MCSPI_IRQSTATUS	MCSPI_IRQSTATUS	0x-
Write MCSPI_IRQSTATUS to reset channel status bits	MCSPI_IRQSTATUS[channel i bits]	0b1111
IF: RXx_FULL		
Read the receiver register	MCSPI_RX_0/1/2/3	0x-
Increment read_count +1		
ENDIF		

13.1.3.5.2.1.8 Transfer Procedures With FIFO

These flows describe the transfer with FIFO.

The MCSPI module allows the transfer of one or several words, according to different modes:

- CONTROLLER Normal, CONTROLLER Turbo, PERIPHERAL
- TRANSMIT-RECEIVE, TRANSMIT-ONLY, RECEIVE-ONLY
- Write and Read requests: IRQ, DMA

For all these flows, the host process contains the main process and the interrupt routine. This routine is called on the IRQ signals or by an internal call if the module is used in polling mode.

For more information, see [Section 13.1.3.4.6, MCSPI FIFO Buffer Management](#).

Table 13-54. FIFO Mode Common Sequence (Controller) (Main Process)

Step	Register/Bit Field/Programming Model	Value
Write MCSPI_IRQSTATUS to reset channel status bits	MCSPI_IRQSTATUS	1
Write MCSPI_IRQENABLE to enable interrupts	MCSPI_IRQENABLE	1

Table 13-54. FIFO Mode Common Sequence (Controller) (Main Process) (continued)

Step	Register/Bit Field/Programming Model	Value
Write MCSPI_CHCONF_0/1/2/3 to configure the channel	MCSPI_CHCONF_0/1/2/3	0x-
Write MCSPI_XFERLEVEL	MCSPI_XFERLEVEL	0x-
Start the channel	MCSPI_CHCTRL_0/1/2/3[0] EN	1
IF: Receive only		
Wait for the write request (TX empty or DMA write)		
Write for the transmitter register with data	MCSPI_TX_0/1/2/3	0x-
ENDIF		
Wait for the host event for end of transfer		
Stop the channel	MCSPI_CHCTRL_0/1/2/3[0] EN	0

13.1.3.5.2.1.8.1 Common Transfer Sequence in FIFO Mode

This flow describes the host sequence for a transfer of any type defined in [Section 13.1.3.5.2.1.8, Transfer Procedures With FIFO](#).

In multi-channel, only one channel can use the FIFO.

Before enabling the FIFO for a channel (MCSPI_CHCONF_0/1/2/3[28] FFER and MCSPI_CHCONF_0/1/2/3[27] FFEW bits), the host must check that the FIFO is not enabled for another channel, even if these channels are not used.

In transmit-and-receive mode, the FIFO can be enabled for write or read request only, without FIFO for the other request.

In Peripheral mode, the channel 0 only can be activated. The correct SPIEN line is chosen in MCSPI_CHCONF_0[22-21] SPIENSLV bits.

The MCSPI module can start the transfer only when the first write request has been released by writing the MCSPI_TX_0/1/2/3 register, even in receive-only mode (only one write request occurs in this case).

13.1.3.5.2.1.8.2 End of Transfer Sequences in FIFO Mode

[Table 13-55](#) summarizes the type of end of transfer per transfer mode and gives a reference to the appropriate section for details.

Table 13-55. End of Transfer Sequences in FIFO Mode

Word count	TRANSMIT AND RECEIVE	TRANSMIT-ONLY	RECEIVE-ONLY
Yes	See Figure 13-51	See Figure 13-53	See Figure 13-54
No	See Figure 13-52	See Figure 13-53	See Figure 13-55

The end of transfer sequences are described from the start of the channel.

In these sequences, some soft variables are used:

- write_count = N
- read_count = N
- last_request = FALSE

They are initialized before starting the channel.

13.1.3.5.2.1.8.3 Transmit-and-Receive With Word Count

[Figure 13-51](#) shows the flow of a transfer in transmit-and-receive mode, with word count.

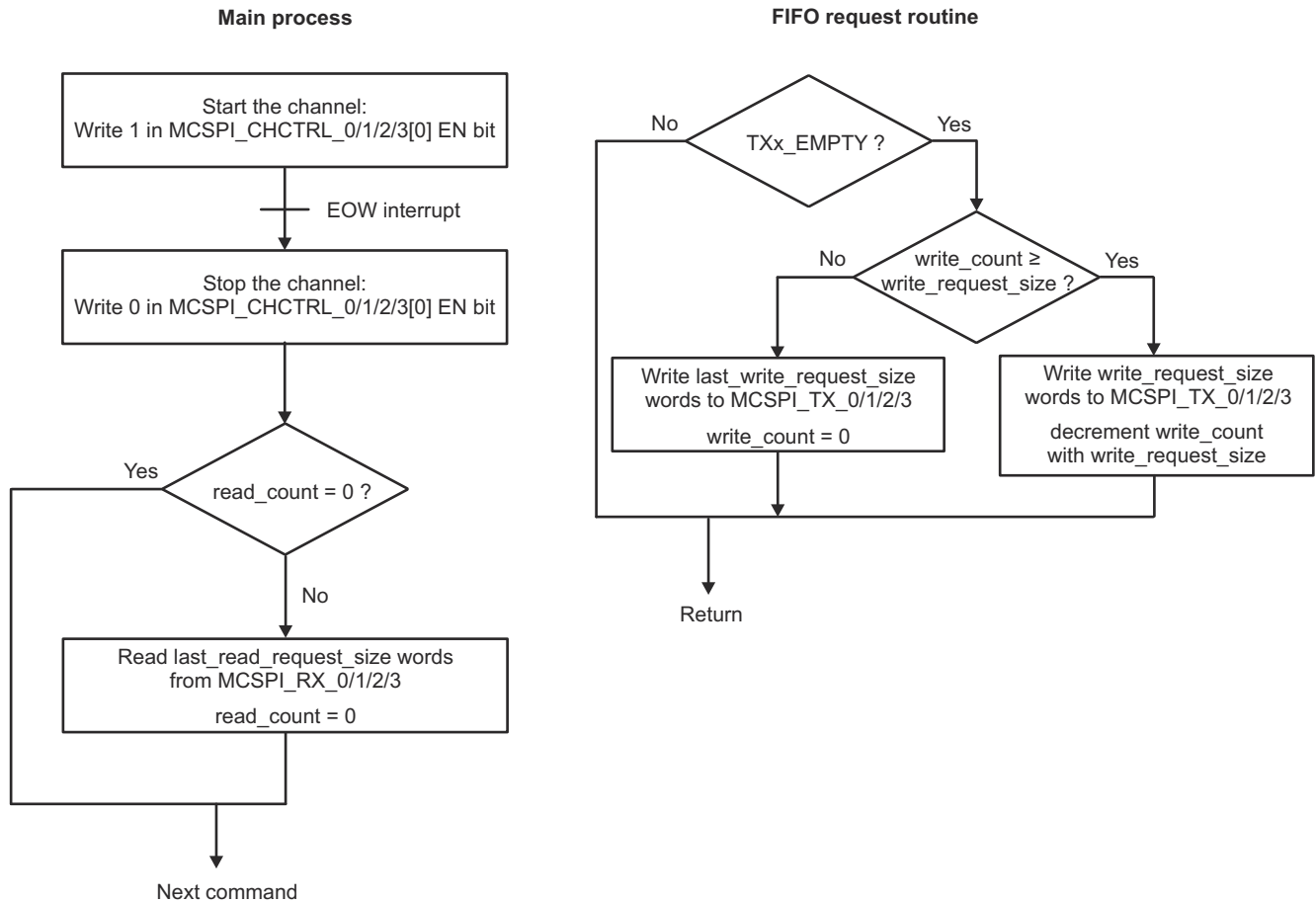

mcspi_025

Figure 13-51. FIFO Mode Transmit-and-Receive With Word Count (Controller)

13.1.3.5.2.1.8.4 Transmit-and-Receive Without Word Count

Figure 13-52 shows the flow of a transfer in transmit-and-receive mode, without word count.

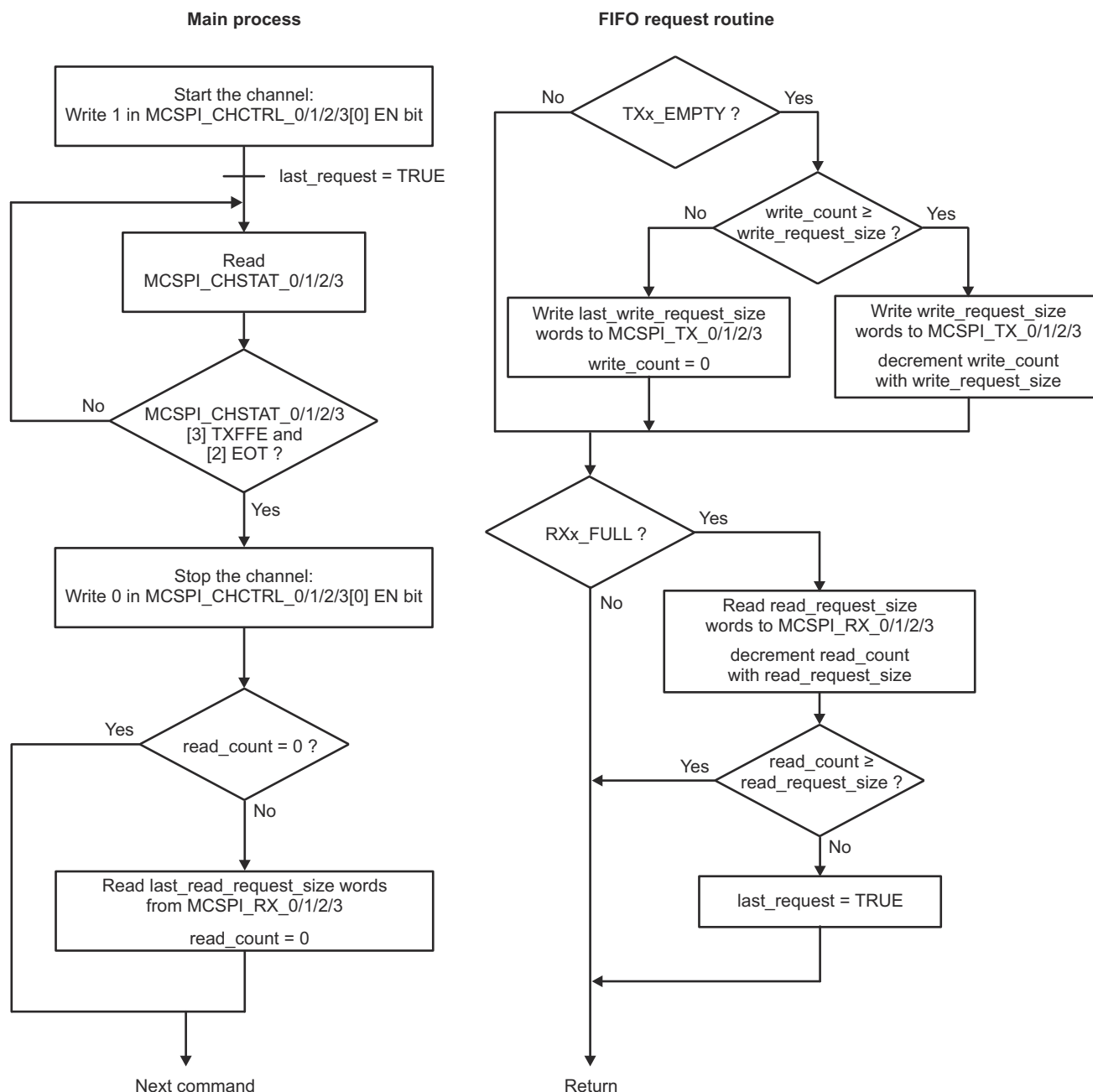

mcspi_026

Figure 13-52. FIFO Mode Transmit-and-Receive Without Word Count (Controller)

13.1.3.5.2.1.8.5 Transmit-Only

Figure 13-53 shows the flow of a transfer in transmit-only mode, with or without word count. The difference between word count enabled or not is just on the condition after starting the channel:

- word count enable: wait for EOW interrupt
- word count disable: wait for write_count = 0

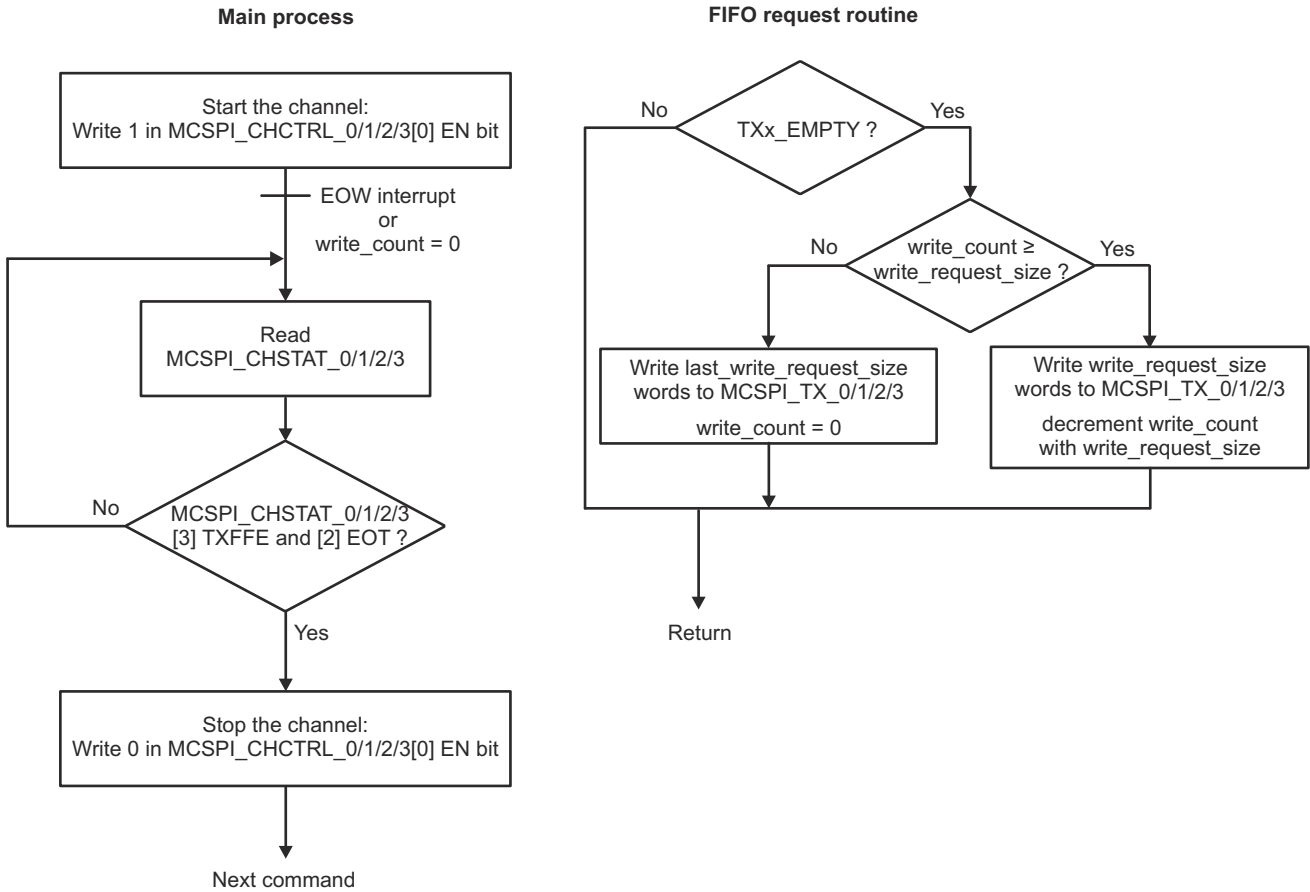

mcspi_027

Figure 13-53. FIFO Mode Transmit-Only (Controller)

13.1.3.5.2.1.8.6 Receive-Only With Word Count

Figure 13-54 shows the flow of a transfer in receive-only mode, with word count.

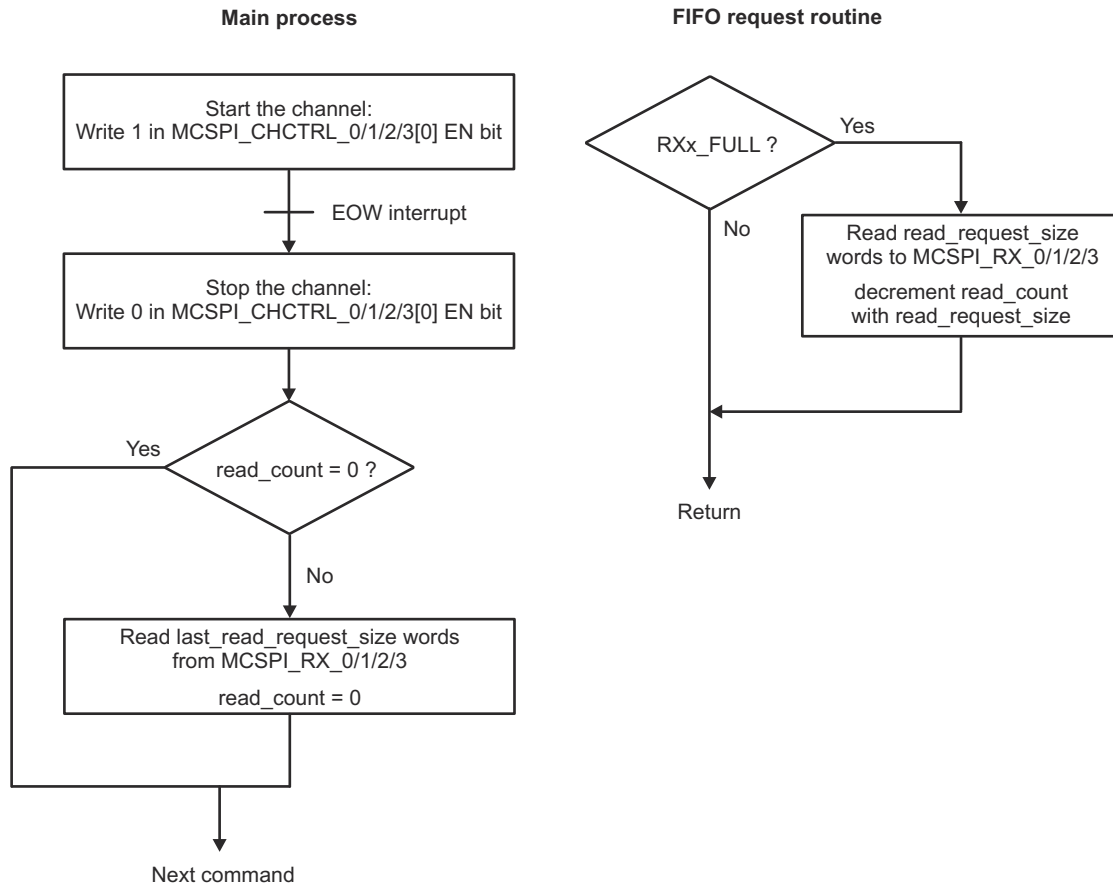

mcspi_028

Figure 13-54. FIFO Mode Receive-Only With Word Count (Controller)

13.1.3.5.2.1.8.7 Receive-Only Without Word Count

Figure 13-55 shows the flow of a transfer in receive-only mode, with word count.

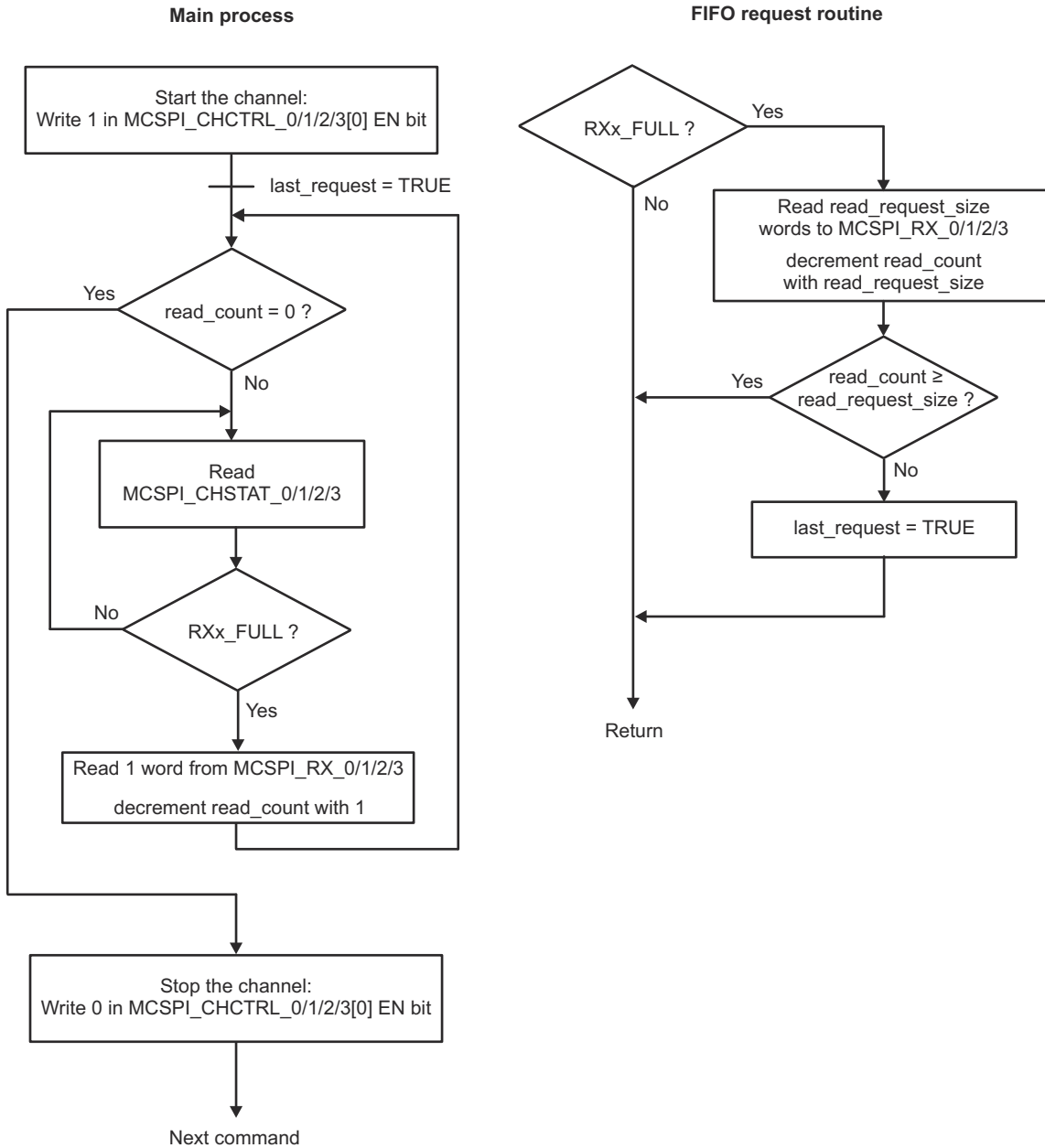

mcspi_029

Figure 13-55. FIFO Mode Receive-Only Without Word Count (Controller)

13.1.3.5.2.1.9 Common Transfer Procedures Without FIFO – Polling Method

13.1.3.5.2.1.9.1 Receive-Only Procedure – Polling Method

Table 13-56 lists the receive-only procedure using the polling method.

Table 13-56. Receive-Only Procedure – Polling Method

Step	Register/Bit Field/Programming Model	Value
Configure the channel according to the mode.	See Table 13-33.	
Start the channel.	MCSPI_CHCTRL_0/1/2/3[0] EN	1
Wait for end-of-transfer.	MCSPI_CHSTAT_0/1/2/3[2] EOT	=1
Read the receiver register.	MCSPI_RX_0/1/2/3	0x-

Table 13-56. Receive-Only Procedure – Polling Method (continued)

Step	Register/Bit Field/Programming Model	Value
Stop the channel if no more data is expected.	MCSPi_CHCTRL_0/1/2/3[0] EN	0

13.1.3.5.2.1.9.2 Receive-Only Procedure – Interrupt Method

Table 13-57 lists the receive-only procedure using the interrupt method.

Table 13-57. Receive-Only Procedure – Interrupt Method

Step	Register/Bit Field/Programming Model	Value
Configure the channel according to the mode.	See Table 13-33.	
Start the channel.	MCSPi_CHCTRL_0/1/2/3[0] EN	1
Enable the interrupt for the receiver register.	MCSPi_IRQENABLE[2] RX_FULL_ENABLE	1
Wait for interrupt.		
Read the status register.	MCSPi_IRQSTATUS[2] RX_FULL	1
Disable the interrupt if no more data is expected.	MCSPi_IRQENABLE[2] RX_FULL_ENABLE	0
Stop the channel if no more data is expected.	MCSPi_CHCTRL_0/1/2/3[0] EN	0
Read the receiver register.	MCSPi_RX_0/1/2/3	0x-

13.1.3.5.2.1.9.3 Transmit-Only Procedure – Polling Method

Table 13-58 lists the transmit-only procedure using the polling method.

Table 13-58. Transmit-Only Procedure – Polling Method

Step	Register/Bit Field/Programming Model	Value
Configure the channel according to the mode.	See Table 13-34.	
Start the channel.	MCSPi_CHCTRL_0/1/2/3[0] EN	1
Write the transmitter register with data.	MCSPi_TX_0/1/2/3	0x-
Wait until end of transfer?	MCSPi_CHSTAT_0/1/2/3[2] EOT	=1
Stop the channel.	MCSPi_CHCTRL_0/1/2/3[0] EN	0

13.1.3.5.2.1.9.4 Transmit-and-Receive Procedure – Polling Method

Table 13-59 lists the transmit-and-receive procedure using the polling method.

Table 13-59. Transmit-and-Receive Procedure – Polling Method

Step	Register/Bit Field/Programming Model	Value
Configure the channel according to the mode.	See Table 13-35.	
Start the channel.	MCSPi_CHCTRL_0/1/2/3[0] EN	1
Write the transmitter register with data.	MCSPi_TX_0/1/2/3	0x-
Wait until transmit/receive word?	MCSPi_CHSTAT_0/1/2/3[2] EOT	=1
Stop the channel.	MCSPi_CHCTRL_0/1/2/3[0] EN	0
Read the receiver register.	MCSPi_RX_0/1/2/3	0x-

13.1.3.5.3 Common Transfer Procedures Without FIFO – Polling Method**13.1.3.5.3.1 Receive-Only Procedure – Polling Method**

Table 13-60 lists the receive-only procedure using the polling method.

Table 13-60. Receive-Only Procedure – Polling Method

Step	Register/Bit Field/Programming Model	Value
Configure the channel according to the mode.	See Table 13-33.	
Start the channel.	MCSPi_CHCTRL_0/1/2/3[0] EN	1
Wait for end-of-transfer.	MCSPi_CHSTAT_0/1/2/3[2] EOT	=1

Table 13-60. Receive-Only Procedure – Polling Method (continued)

Step	Register/Bit Field/Programming Model	Value
Read the receiver register.	MCSPi_RX_0/1/2/3	0x-
Stop the channel if no more data is expected.	MCSPi_CHCTRL_0/1/2/3[0] EN	0

13.1.3.5.3.2 Receive-Only Procedure – Interrupt Method

Table 13-61 lists the receive-only procedure using the interrupt method.

Table 13-61. Receive-Only Procedure – Interrupt Method

Step	Register/Bit Field/Programming Model	Value
Configure the channel according to the mode.	See Table 13-33.	
Start the channel.	MCSPi_CHCTRL_0/1/2/3[0] EN	1
Enable the interrupt for the receiver register.	MCSPi_IRQENABLE[2] RX_FULL_ENABLE	1
Wait for interrupt.		
Read the status register.	MCSPi_IRQSTATUS[2] RX_FULL	1
Disable the interrupt if no more data is expected.	MCSPi_IRQENABLE[2] RX_FULL_ENABLE	0
Stop the channel if no more data is expected.	MCSPi_CHCTRL_0/1/2/3[0] EN	0
Read the receiver register.	MCSPi_RX_0/1/2/3	0x-

13.1.3.5.3.3 Transmit-Only Procedure – Polling Method

Table 13-62 lists the transmit-only procedure using the polling method.

Table 13-62. Transmit-Only Procedure – Polling Method

Step	Register/Bit Field/Programming Model	Value
Configure the channel according to the mode.	See Table 13-34.	
Start the channel.	MCSPi_CHCTRL_0/1/2/3[0] EN	1
Write the transmitter register with data.	MCSPi_TX_0/1/2/3	0x-
Wait until end of transfer?	MCSPi_CHSTAT_0/1/2/3[2] EOT	=1
Stop the channel.	MCSPi_CHCTRL_0/1/2/3[0] EN	0

13.1.3.5.3.4 Transmit-and-Receive Procedure – Polling Method

Table 13-63 lists the transmit-and-receive procedure using the polling method.

Table 13-63. Transmit-and-Receive Procedure – Polling Method

Step	Register/Bit Field/Programming Model	Value
Configure the channel according to the mode.	See Table 13-35.	
Start the channel.	MCSPi_CHCTRL_0/1/2/3[0] EN	1
Write the transmitter register with data.	MCSPi_TX_0/1/2/3	0x-
Wait until transmit/receive word?	MCSPi_CHSTAT_0/1/2/3[2] EOT	=1
Stop the channel.	MCSPi_CHCTRL_0/1/2/3[0] EN	0
Read the receiver register.	MCSPi_RX_0/1/2/3	0x-

13.1.4 Universal Asynchronous Receiver/Transmitter (UART)

This chapter describes the function, operation, and configuration of the Universal Asynchronous Receiver/Transmitter (UART)/RS-485/Infrared Data Association (IrDA)/Consumer Infrared (CIR) module in the device.

Note

UART and USART acronyms are used interchangeably in this section.

13.1.4.1 UART Overview.....	979
13.1.4.2 UART Environment.....	981
13.1.4.3 UART Integration.....	997
13.1.4.4 UART Functional Description.....	1004
13.1.4.5 UART Programming Guide.....	1040

13.1.4.1 UART Overview

The UART is a target peripheral that utilizes the DMA for data transfer or interrupt polling via host CPU. There are six UART modules in the device. The UART modules support IrDA and CIR modes when a 48 MHz functional clock frequency is used. Each UART can be used for configuration and data exchange with a number of external peripheral devices or interprocessor communication between devices.

13.1.4.1.1 UART Features

The UART includes the following features:

- 16C750-compatible
- RS-485 external transceiver auto flow control support
- 64-byte FIFO buffer for receiver and 64-byte FIFO buffer for transmitter
- Programmable interrupt trigger levels for FIFOs
- Programmable sleep mode
- The 48 MHz functional clock is default option and allows baud rates up to 3.6 Mbps
- Auto-baud between 1200 bits/s and 115.2 Kbits/s (only when 48 MHz function clock is used)
- Optional multi-drop transmission
- Configurable time-guard feature
- Configurable data format:
 - Data bit: 5, 6, 7, 8, or 9 bits
 - Parity bit: Even, odd, none
 - Stop-bit: 1, 1.5, 2 bit(s)
- Flow control: Hardware (RTS/CTS) or software (XON/XOFF)
- False start bit detection
- Line break generation and detection
- Fully prioritized interrupt system controls
- Internal test and loopback capabilities
- Modem control functions (CTS, RTS)
- UART1 module instance has extended modem control signals (DCD, RI, DTR, DSR)

13.1.4.1.2 IrDA Features

The IrDA includes the following features:

- Support of IrDA 1.4 slow infrared (SIR), medium infrared (MIR), and fast infrared (FIR) communications:
 - Slow infrared (SIR 115.2 KBAUD), medium infrared (MIR 0.576 MBAUD) and fast infrared (FIR 4.0 MBAUD) operations (very fast infrared (VFIR) is not supported)
 - Frame formatting: addition of variable beginning-of-frame (xBOF) characters and end-of-frame (EOF) characters
 -
 - Asynchronous transparency (automatic insertion of break character)
 - Eight-entry status FIFO (with selectable trigger levels) to monitor frame length and frame errors
 - Framing error, CRC error, illegal symbol (FIR), and abort pattern (SIR, MIR) detection
- IrDA mode when 48 MHz function clock is used

13.1.4.1.3 CIR Features

The CIR mode uses a variable pulse-width modulation (PWM) technique (based on multiples of a programmable t period) to encompass the various formats of infrared encoding for remote-control applications. The CIR logic transmits data packets based on a user-definable frame structure and packet content.

The CIR includes the following features to provide CIR support for remote-control applications:

- Transmit and receive mode
- Free data format (supports any remote-control private standards)
- Selectable bit rate
- Configurable carrier frequency
- 1/2, 5/12, 1/3, or 1/4 carrier duty cycle

- CIR mode when 48 MHz function clock is used

13.1.4.1.4 UART Not Supported Features

- Synchronous mode
- ISO7816 mode
- DMA mode 2
- Full modem handshaking is not available on all instances - see device datasheet for details
- Multi-drop transmission
- 9-bit mode
- 12 Mbps operation

13.1.4.2 UART Environment

The , UART[0-5] modules are hereinafter referred to as UART module.

This section describes the UART/RS-485/IrDA/CIR external connections (environment).

- The UART interface is described in [Section 13.1.4.2.1, UART Functional Interfaces](#).
- The RS-485 interface is described in [Section 13.1.4.2.2, RS-485 Functional Interfaces](#).
- The IrDA interface is described in [Section 13.1.4.2.3, IrDA Functional Interfaces](#).
- The CIR interface is described in [Section 13.1.4.2.4, CIR Functional Interfaces](#).

13.1.4.2.1 UART Functional Interfaces

13.1.4.2.1.1 System Using UART Communication With Hardware Handshake

Each UART instance can be easily connected to the UART port of an external IC (see [Figure 13-56](#)).

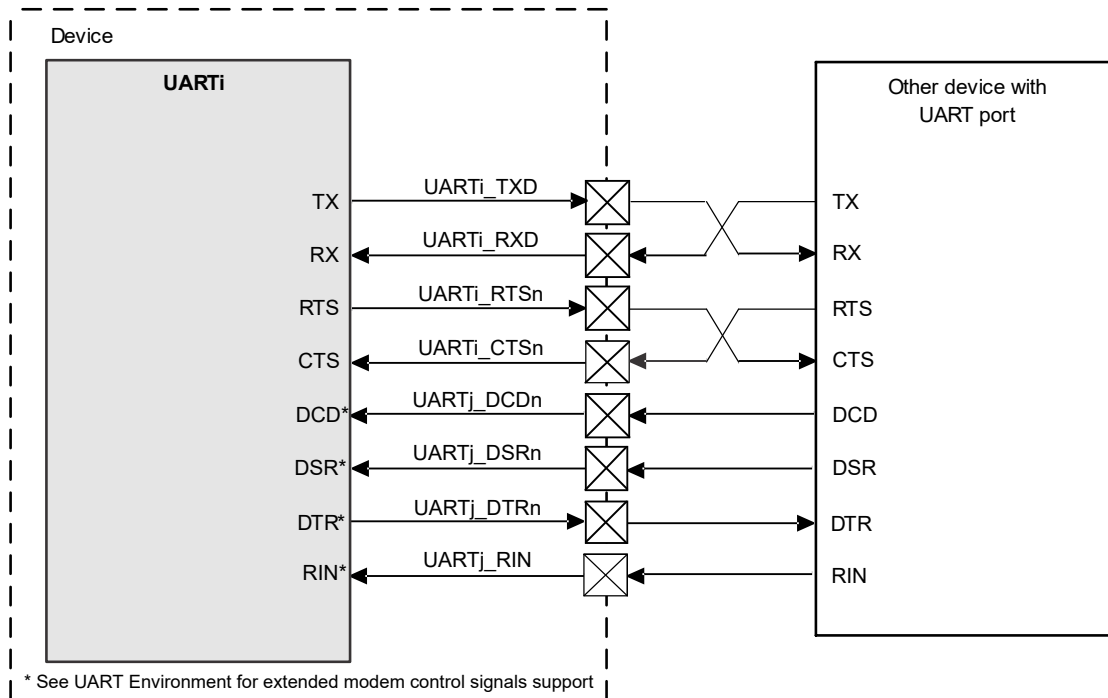

Figure 13-56. UART Mode Interface Signals

13.1.4.2.1.2 UART Interface Description

Table 13-64 lists the UART interface input/output (I/O) signals.

Table 13-64. UART I/O Signals

Module Pin Name	Device Level Signal Name	I/O ⁽¹⁾	Description	Module Pin Reset Value ⁽²⁾
UART[0-5]				
RX	UART[0-5]_RXD	I	Serial data input	HiZ
TX	UART[0-5]_TXD	O	Serial data output ⁽³⁾	1
CTS	UART[0-5]_CTS _n	I	Clear to send ⁽⁴⁾	HiZ
RTS	UART[0-5]_RTS _n	O	Request to send ⁽⁵⁾	1
UART1 Modem Signals				
DCD	UART1_DCD _n	I	Data Carrier Detect ⁽⁶⁾	HiZ
DSR	UART1_DSR _n	I	Data Set Ready ⁽⁷⁾	HiZ
DTR	UART1_DTR _n	O	Data Terminal Ready ⁽⁸⁾	1
RIN	UART1_RIN	I	Ring Indicator ⁽⁹⁾	HiZ

(1) I = Input; O = Output

(2) HiZ = High Impedance

(3) Because this pin is active high in IrDA mode and the output is muxed, this pin is set to low on reset (when the UART_MDR1[2-0] bit field is set to 0x7) and takes the defined inactive level of that signal corresponding to when and how the UART_MDR1 register is programmed; that is, the output is 1 (inactive for UART modem modes) and 0 (inactive for IrDA modes).

(4) Active-low modem status signal. Reading the UART_MSR[4] NCTS_STS bit checks the condition of CTS. Reading the UART_MSR[0] CTS_STS bit checks a change of state of CTS since the last read of the modem status register. The auto-CTS mode uses CTS to control the transmitter.

(5) When active (low), the module is ready to receive data. Setting the UART_MCR[1] RTS bit activates RTS signal, which becomes inactive as the result of a module reset, loopback mode, or clearing the UART_MCR[1] RTS bit. In auto-RTS mode, RTS signal becomes inactive as a result of the receiver threshold logic.

(6) Active-low modem status signal. The condition of DCD can be checked by reading the UART_MSR[7] NCD_STS bit. Any change in its state can be detected by reading the UART_MSR[3] DCD_STS bit.

(7) Active-low modem status signal. Reading the UART_MSR[5] NDSR_STS bit checks the condition of DSR. Reading the UART_MSR[1] DSR_STS bit checks a change of state of DSR since the last read of the UART_MSR register.

(8) When active (low), this signal informs the modem that the module is ready to communicate. It is activated by setting the UART_MCR[0] DTR bit.

(9) Active-low modem status signal. The condition of RIN can be checked by reading the UART_MSR[6] NRI_STS bit. Any change in its state can be detected by reading the UART_MSR[2] RI_STS bit.

Note

For more information about device level signals (pull-up/down resistors, buffer type, multiplexing and others), see tables *Pin Attributes* and *Pin Multiplexing* in the device-specific Datasheet.

13.1.4.2.1.3 UART Protocol and Data Format

The UART device operates in three modes:

- UART 16× (<= 230.4 kbps)
- UART 16× with autobauding (>= 1200 bps and <= 115.2 kbps)
- UART 13× (>= 460.8 kbps)

CAUTION

To be used as a UART, the operating mode must be programmed appropriately in the UART_MDR1[2-0] MODE_SELECT bit field to select UART, IrDA, or CIR mode, and the UART_MDR3[4] DIR_EN bit field to select RS-485 mode.

The UART uses a wired interface for serial communication with a remote device.

The UART is functionally compatible with the TL16C750 UART and earlier designs such as the TL16C550.

Figure 13-57 shows the UART frame data format.

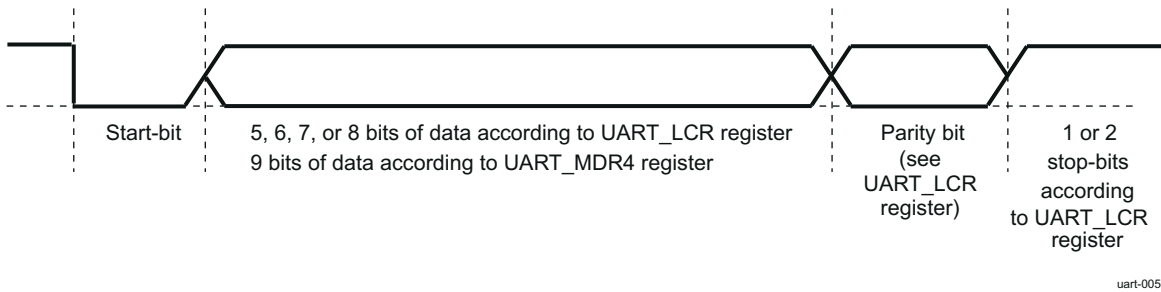

Figure 13-57. UART Frame Data Format

Note

Not all operating modes are described in the diagram. The UART module is capable of supporting a 9-bit mode that is not shown in the diagram.

13.1.4.2.2 RS-485 Functional Interfaces

13.1.4.2.2.1 System Using RS-485 Communication

The RS-485 network physical layer consists of two-wire differential bus, usually twisted pair. External RS-485 transceiver IC is needed to access a RS-485 bus by the RS-485 mode. Figure 13-58 shows an example connection of MCU_UART0 in RS-485 mode.

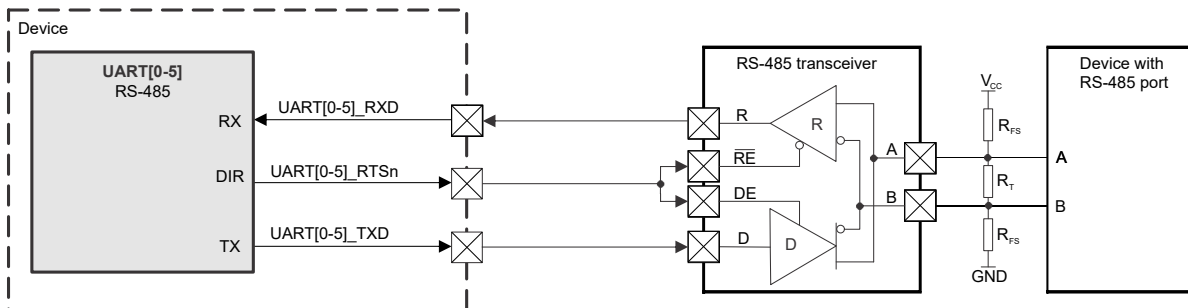

Figure 13-58. RS-485 Mode Interface Signals

13.1.4.2.2.2 RS-485 Interface Description

Table 13-65 lists the RS-485 interface input/output (I/O) signals.

Table 13-65. UART I/O Signals (RS-485 Mode)

Module Pin	Device Level Signal	I/O ⁽¹⁾	Description	Module Pin Reset Value ⁽²⁾
RX		I	Serial data input	HiZ
TX		O	Serial data output	1
DIR		O	RS-485 Direction	1
RX		I	Serial data input	HiZ
TX		O	Serial data output	1
DIR		O	RS-485 Direction	1

(1) I = Input; O = Output

(2) HiZ = High Impedance

Note

For more information about device level signals (pull-up/down resistors, buffer type, multiplexing and others), see tables *Pin Attributes* and *Pin Multiplexing* in the device-specific Datasheet.

13.1.4.2.3 IrDA Functional Interfaces

13.1.4.2.3.1 System Using IrDA Communication Protocol

Figure 13-59 shows an example connection of UART0 to an external infrared transceiver in the IrDA modes (FIR, SIR, and MIR).

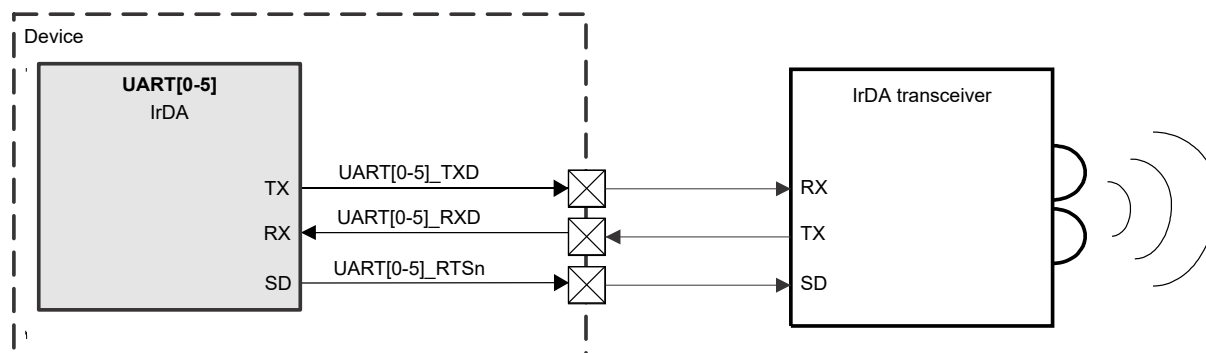

Figure 13-59. IrDA Mode Interface Signals

13.1.4.2.3.2 IrDA Interface Description

Table 13-66 lists the IrDA interface I/O signals.

Table 13-66. UART I/O Signals (IrDA Mode)

Module Pin	Device Level Signal	I/O ⁽¹⁾	Description	Module Pin Reset Value ⁽²⁾
RX		I	Serial data input	HiZ
TX		O	Serial data output in IrDA modes (SIR, MIR, and FIR). ⁽³⁾	0
SD		O	SD mode is used to configure the transceivers. ⁽⁴⁾	1
RX		I	Serial data input	HiZ
TX		O	Serial data output in IrDA modes (SIR, MIR, and FIR). ⁽³⁾	0
SD		O	SD mode is used to configure the transceivers. ⁽⁴⁾	1

(1) I = Input; O = Output

(2) HiZ = High Impedance

(3) In other modes, this pin is set to the reset value (inactive state).

(4) The SD pinout (see UART_ACREG[6] SD_MOD bit).

Note

For more information about device level signals (pull-up/down resistors, buffer type, multiplexing and others), see tables *Pin Attributes* and *Pin Multiplexing* in the device-specific Datasheet.

13.1.4.2.3.3 IrDA Protocol and Data Format

13.1.4.2.3.3.1 SIR Mode

In SIR mode, data is transferred between the Host CPU and peripheral devices at speeds of up to 115200 baud. A SIR transmit frame begins with start flags (a single 0xC0, a multiple 0xC0, or a single 0xC0 preceded by a number of 0xFF flags), followed by frame data and a CRC-16, and ends with a stop flag (0xC1).

The bit format for a single word uses 1 start-bit, 8 data bits, and 1 stop-bit, and is unaffected by the use and settings of the UART_LCR register.

The UART_BLR[6] XBOF_TYPE bit selects whether the 0xC0 or 0xFF start patterns are used when multiple start flags are required.

The SIR transmit state-machine attaches start flags, CRC-16, and stop flags, and checks the outgoing data to establish whether data transparency is required.

The SIR transparency is carried out if the outgoing data between the start and stop flags contains 0xC0, 0xC1, or 0x7D. If one of these start flags is about to be transmitted, the SIR state-machine sends an escape character (0x7D), inverts the fifth bit of the real data to be sent, and then sends this data immediately after the 0x7D character.

The SIR receive state-machine recovers the receive clock, removes the start flags and any transparency from the incoming data, and determines the frame boundary with reception of the stop flag. The SIR state-machine also checks for errors such as a frame abort (0x7D character followed immediately by a 0xC1 stop flag without transparency), a CRC error, or a frame-length error. At the end of a frame reception, the Host CPU reads the line status register (UART_LSR_IRDA) to find possible errors of the received frame.

Note

The module can transmit and receive data, but when the device is transmitting, the IR RX circuitry is automatically disabled by hardware. See the description of the UART_ACREG[5] DIS_IR_RX bit. This applies to all three modes: SIR, MIR, and FIR.

Infrared output in SIR mode can be 1.6- μ s or 3/16 encoding, selected by the UART_ACREG[7] PULSE_TYPE bit. In 1.6- μ s encoding, the infrared pulse width is 1.6 μ s; and in 3/16th encoding, the infrared pulse width is 3/16th of a bit duration (1/ baud rate).

For back-to-back frames, the transmitting device must send at least two start flags at the start of each frame.

Note

Reception supports variable-length stop-bits.

13.1.4.2.3.3.1.1 Frame Format

Figure 13-60 shows the IrDA SIR frame format.

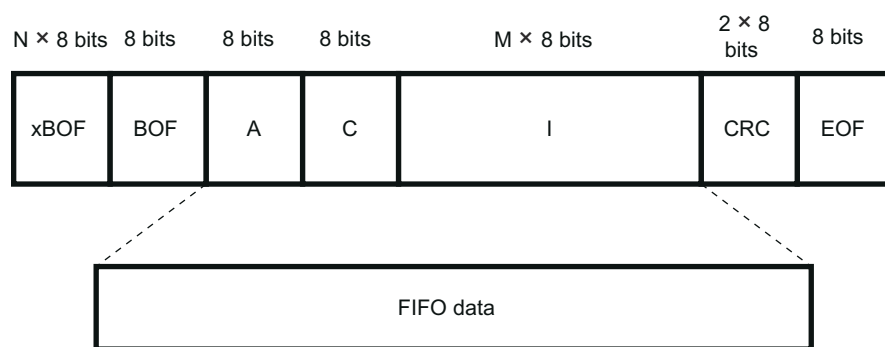

uart-006

Figure 13-60. IrDA SIR Frame Format

The CRC is applied on the address (A), control (C), and information (I) bytes.

Note

The two words of CRC are written to the FIFO in reception.

13.1.4.2.3.3.1.2 Asynchronous Transparency

Before transmitting a byte, the UART IrDA controller examines each byte of the payload and the CRC field (between BOF and EOF). For each byte equal to 0xC0 (BOF), 0xC1 (EOF), or 0x7D (control escape), the controller performs certain tasks:

- In transmission:
 - Inserts a control escape (CE) byte preceding the byte
 - Complements bit 5 of the byte (that is, exclusive ORs the byte with 0x20)

The byte sent for the CRC computation is the initial byte written in the TX FIFO (before the XOR with 0x20).

- In reception:

For the A, C, I, and CRC fields:

- Compares the byte with the CE byte; if they are not equal, sends the byte to the CRC detector and stores it in the RX FIFO.
- If the byte is equal to the CE byte, discards the CE byte
- Complements bit 5 of the byte following the CE
- Sends the complemented byte to the CRC detector and stores it in the RX FIFO

13.1.4.2.3.3.1.3 Abort Sequence

The transmitter can prematurely close a frame (abort) by sending the sequence 0x7DC1. The abort pattern closes the frame without a CRC field or an ending flag.

When a 0x7D character that is followed immediately by a 0xC1 character is received without transparency, the receiver treats the frame as an aborted frame.

13.1.4.2.3.3.1.4 Pulse Shaping

The SIR mode supports the 3/16 and the 1.6-μs pulse duration methods. The UART_ACREG[7] PULSE_TYPE bit selects the pulse-width method in transmit mode.

13.1.4.2.3.3.1.5 Encoder

Serial data from the transmit state-machine are encoded to transmit data to the optoelectronics. While the TX FIFO output is high, the TX line is always low, and the counter used to form a pulse on TX is cleared continuously.

After the TX FIFO output resets to 0, TX rises on the falling edge of the seventh 16XCLK. On the falling edge of the tenth 16XCLK pulse, TX falls, creating a 3-clock-wide pulse. While the TX FIFO output stays low, a pulse is transmitted during the seventh clock to the tenth clock of each 16-clock bit cycle.

Figure 13-61 shows the IrDA SIR encoding mechanism.

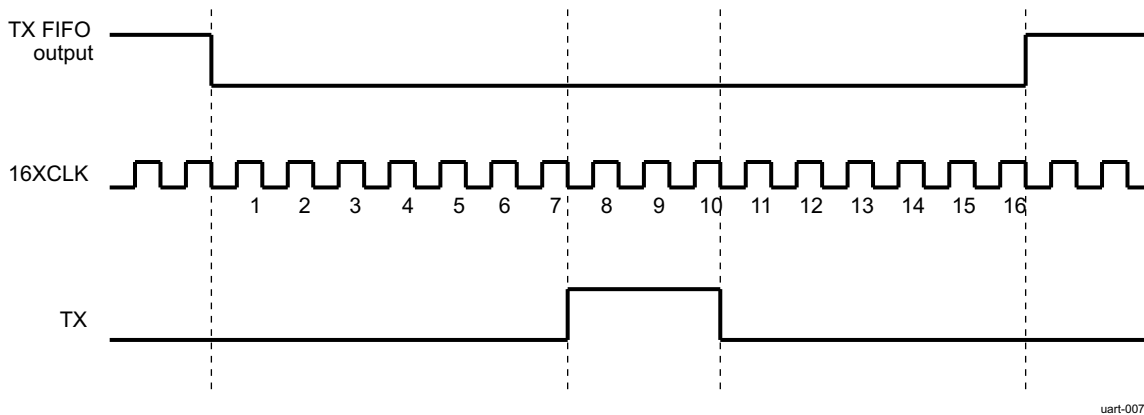
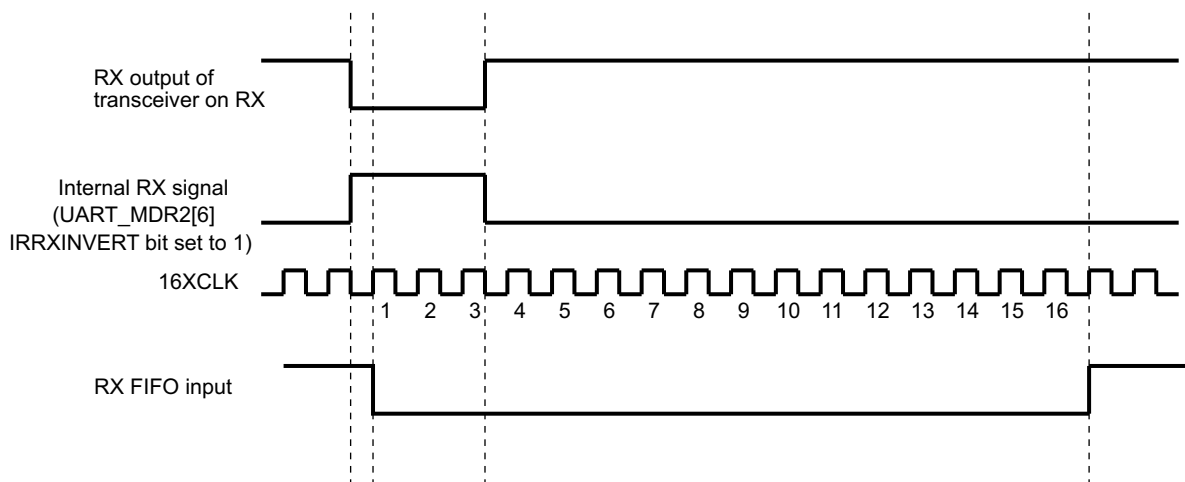

Figure 13-61. IrDA SIR Encoding Mechanism

13.1.4.2.3.3.1.6 Decoder

After reset, the RX FIFO input is high and the 4-bit counter is cleared. When a rising edge is detected on RX, the RX FIFO input falls on the next rising edge of 16XCLK with sufficient setup time. The RX FIFO input stays low for 16 cycles (16XCLK) and then returns to high as required by the IrDA specification. As long as no pulses (rising edges) are detected on the RX, the RX FIFO input remains high.

Figure 13-62 shows the IrDA SIR decoding mechanism.



uart-008

Figure 13-62. IrDA SIR Decoding Mechanism

The module can transmit and receive data, but when the device is transmitting, the IR RX circuitry is automatically disabled by hardware. The operation of the RX input can be disabled using the UART_ACREG[5] DIS_IR_RX bit. The UART_MDR2[6] IRRXINVERT bit can invert the signal from the transceiver (RX) pin to the IR RX logic in the UART. This inversion is performed by default.

13.1.4.2.3.3.1.7 IR Address Checking

In all IR modes, when address checking is enabled by setting the UART_EFR[1-0] bit field (see [Table 13-67](#)), only frames intended for the device are written to the RX FIFO. This is to avoid receiving frames not meant for this device in a multipoint infrared environment. To program two frame addresses that the UARTi receives in IrDA mode, use the UART_XON1_ADDR1[7-0] and UART_XON2_ADDR2[7-0] bit fields.

Table 13-67. UART_EFR[1-0] IR Address Checking Options

UART_EFR[1]	UART_EFR[0]	IR Address Checking
0	0	All address-checking operations disabled
0	1	Only address 1 checking enabled
1	0	Only address 2 checking enabled
1	1	All address-checking operations enabled

13.1.4.2.3.3.2 SIR Free-Format Mode

To allow complete software flexibility when transmitting and receiving infrared data packets, the SIR free-format (FF) mode is a subfunction of the existing SIR mode. In FF mode, all frames going to and from the FIFO buffers are untouched with respect to appending and removing control characters and CRC values.

The FF mode corresponds to a UART mode with a pulse modulation of 3/16 of baud rate pulse width.

For example, a normal SIR packet has BOF control and CRC error-checking data appended (transmitting) or removed (receiving) from the data going to and from the FIFOs.

[Figure 13-63](#) shows SIR FF mode.

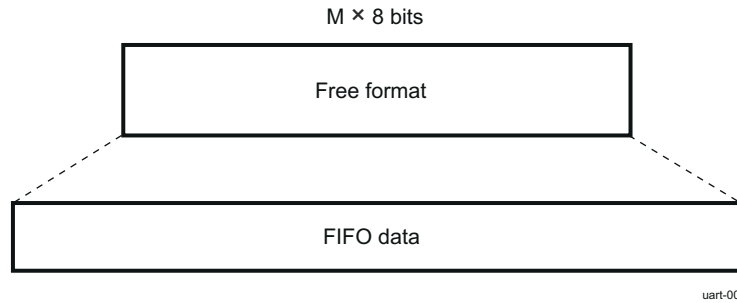

Figure 13-63. SIR FF Mode

In SIR FF mode, the Host CPU software must construct (that is, encode and decode) the entire FIFO data packet.

13.1.4.2.3.3.3 MIR Mode

In MIR mode, data is transferred between the Host CPU and the peripheral devices at 0.576 Mbps or 1.152 Mbps. A MIR transmit frame starts with at least two start flags, followed by a frame data and a CRC-16, and ends with a stop flag (see Figure 13-64).

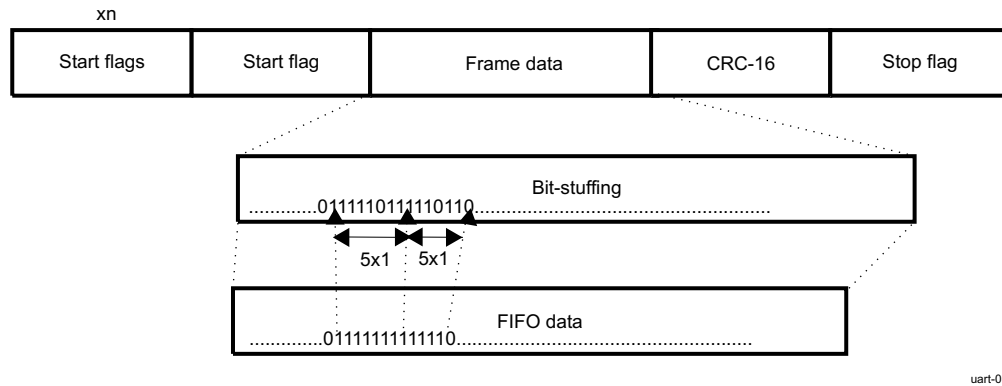

Figure 13-64. MIR Transmit Frame Format

On transmit, the MIR state-machine attaches start flags, a CRC-16, and stop flags, as in SIR mode. All fields are transmitted least-significant bit (LSB) of each byte first.

In MIR mode:

- The state-machine looks for consecutive 1s in the frame data and automatically inserts 0 after five consecutive 1s (this is called bit-stuffing).
- 0x7E is used for start and stop flags (unambiguously, not data, because of bit-stuffing).
- An abort sequence requires a minimum of seven consecutive 1s (unambiguously, not data, because of bit-stuffing).
- Back-to-back frames are allowed with three or more stop flags between them. If two consecutive frames are not back to back, the gap between the last stop flag of the first frame and the start flag of the second frame must be separated by at least seven bit durations.

On receive, the MIR receive state-machine recovers the receive clock, removes the start flags, destuffs the incoming data, and determines the frame boundary with reception of the stop flag. The state-machine also checks for errors such as frame abort, CRC error, and frame-length error. At the end of a frame reception, the Host CPU reads the line status register (UART_LSR_IRDA) to detect errors of the received frame.

The module can transmit and receive data, but when the device is transmitting, the IR RX circuitry is automatically disabled by hardware.

13.1.4.2.3.3.3.1 MIR Encoder/Decoder

To meet the MIR baud rate tolerance of 0.1 percent with a 48-MHz clock input, a 42-41-42 encoding/decoding adjustment is performed. The reference start point is the first start flag, and the 42-41-42 cyclic pattern is repeated until the stop flag is sent or detected.

The jitter created this way is within MIR tolerances. The pulse width is not exactly 1/4, but it is within the tolerances defined by IrDA specifications.

Figure 13-65 shows the MIR baud rate adjustment mechanism.

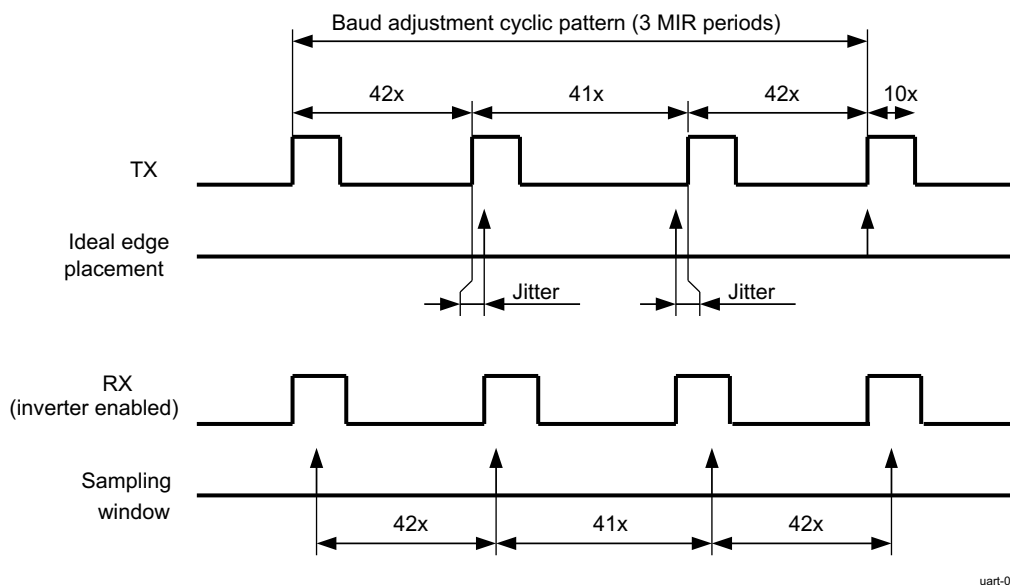

uart-011

Figure 13-65. MIR Baud Rate Adjustment Mechanism

13.1.4.2.3.3.3.2 SIP Generation

In the MIR and FIR operation modes, the transmitter must send a serial infrared interaction pulse (SIP) at least once every 500 ms. The SIP informs slow devices (operating in SIR mode) that the medium is occupied.

Figure 13-66 shows the SIP.

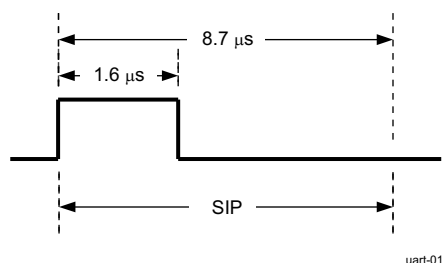

uart-012

Figure 13-66. SIP

13.1.4.2.3.3.4 FIR Mode

In FIR mode, data is transferred between the Host CPU and the peripheral devices at 4 Mbps. A FIR transmit frame starts with a preamble that is followed by a start flag, frame data, CRC-32, and ends with a stop flag.

Figure 13-67 shows the FIR transmit frame format.

Figure 13-67. FIR Transmit Frame Format

Preamble (16x)	Start flag	Frame data	CRC-32	Stop flag
----------------	------------	------------	--------	-----------

On transmit, the FIR transmit state-machine attaches the preamble, start flag, CRC-32, and stop flag. An abort sequence requires at least two transmissions of 0000. Back-to-back frames are allowed, but each frame must be complete.

The state-machine also encodes the transmit data into 4-PPM format (see [Table 13-68](#)) and generates the SIP (see [Section 13.1.4.2.3.3.3.2, SIP Generation](#)).

Table 13-68. 4-PPM Format

Data Bit Pair (Bin)	4-PPM Data Symbol (Bin)
00	1000
01	0100
10	0010
11	0001

The four symbols described in [Table 13-68](#) are the legal, encoded data symbols. All other combinations are illegal for encoding data. Some of these illegal symbols are used in the definition of the preamble, start flag, and stop flag because they are unambiguously not data (see [Table 13-69](#)).

Table 13-69. FIR Preamble, Start Flag, and Stop Flag

Frame Part	Transmitted Frame (Bin)
Preamble	1000 0000 1010 1000 (16 repeated transmissions)
Start flag	0000 1100 0000 1100 0110 0000 0110 0000
Stop flag	0000 1100 0000 1100 0000 0110 0000 0110

All fields are transmitted LSBs of each byte first (see [Table 13-70](#)).

Table 13-70. FIR Data Byte Transmission Order Example

Data Byte (Hex)	Data Byte Pair (Bin)	4-PPM Data Symbol (Bin)	Transmission Order
0x0B	00	1000	4
	00	1000	3
	10	0010	2
	11	0001	1

On receive, the FIR receive state-machine recovers the receive clock, removes the preamble and the start flag, decodes the 4-PPM incoming data, and determines the frame boundary with reception of the stop flag. The state-machine also checks for errors such as illegal symbol, CRC error, and frame-length error. At the end of a frame reception, the Host CPU reads the line status register (UART_LSR_IRDA) to detect errors of the received frame.

The module can transmit and receive data, but when the device is transmitting, the IR RX circuitry is automatically disabled by hardware.

13.1.4.2.4 CIR Functional Interfaces

13.1.4.2.4.1 System Using CIR Communication Protocol With Remote Control

All UART modules can be connected to an external infrared transceiver in CIR mode. [Figure 13-68](#) shows an example connection of UART0 in CIR mode.

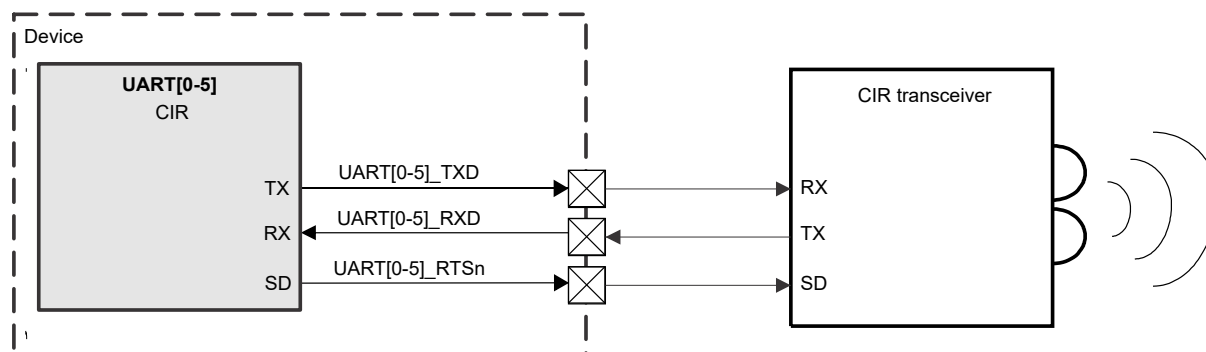
Figure 13-68. CIR Mode Interface Signals

13.1.4.2.4.2 CIR Interface Description

Table 13-71 lists the CIR interface I/O signals.

Table 13-71. UART I/O Signals (CIR Mode)

Module Pin	Device Level Signal	I/O ⁽¹⁾	Description	Module Pin Reset Value ⁽²⁾
RX		I	Serial data input	HiZ
TX		O	Serial data output in CIR mode. ⁽³⁾	0
SD		O	SD mode is used to configure the transceivers. ⁽⁴⁾	1
UART[0-9]				
RX		I	Serial data input	HiZ
TX		O	Serial data output in CIR mode. ⁽³⁾	0
SD		O	SD mode is used to configure the transceivers. ⁽⁴⁾	1

(1) I = Input; O = Output

(2) HiZ = High Impedance

(3) In other modes, this pin is set to the reset value (inactive state).

(4) The SD pinout is an inverted value of the UART_ACREG[6] SD_MOD bit.

Note

For more information about device level signals (pull-up/down resistors, buffer type, multiplexing and others), see tables *Pin Attributes* and *Pin Multiplexing* in the device-specific Datasheet.

13.1.4.2.4.3 CIR Protocol and Data Format

In CIR mode, the infrared operation functions as a programmable (universal) remote control.

The CIR mode uses a variable PWM technique (based on multiples of a programmable t period) to encompass the various formats of infrared encoding for remote-control applications. The CIR logic transmits data packets based on user-defined frame structure and packet content.

13.1.4.2.4.3.1 Carrier Modulation

Each modulated pulse that constitutes a digit is a train of on/off pulses (see Figure 13-69).

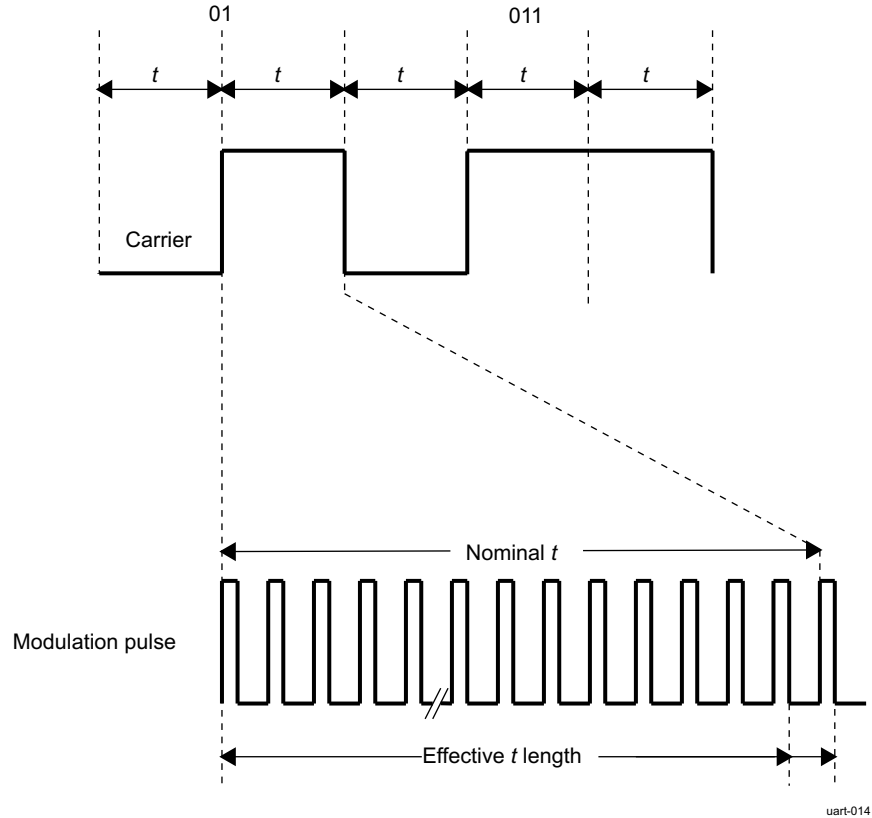

Figure 13-69. CIR Pulse Modulation

13.1.4.2.4.3.2 Pulse Duty Cycle

The programmer can choose one of four duty cycles for modulation pulses by setting the appropriate value in the [5-4] CIR_PULSE_MODE bit field (1/4, 1/3, 5/12, or 1/2).

Figure 13-70 shows the CIR modulation duty cycles.

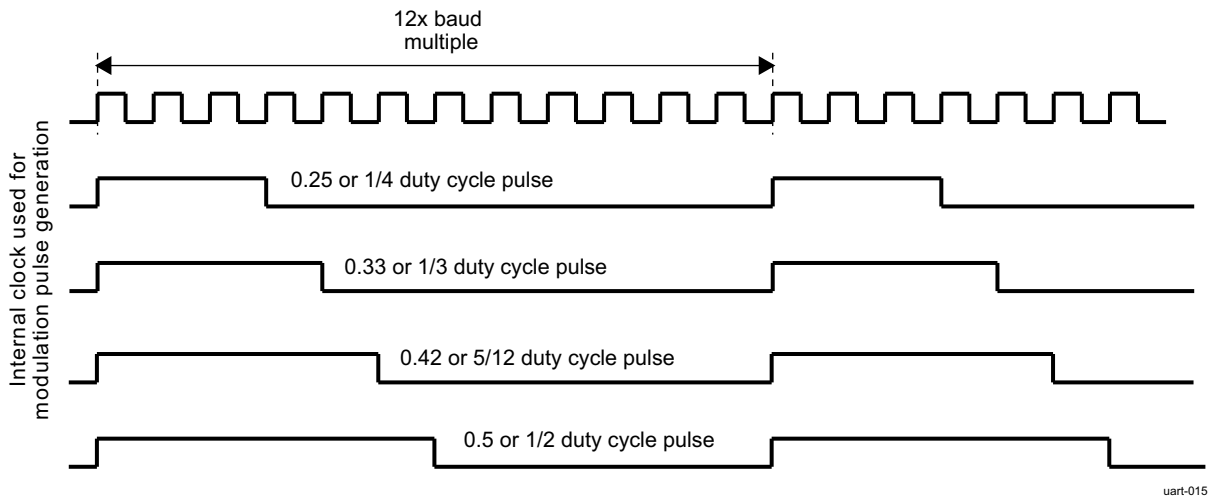

Figure 13-70. CIR Modulation Duty Cycle

The transmission logic ensures that all pulses are transmitted completely (no cutoff during transmission). While transmitting continuous bytes back-to-back, no delay is inserted between 2 transmitted bytes. Thus, software must handle the delay between consecutively transmitted bytes if the receiving end requires it.

13.1.4.2.4.3.3 Consumer IR Encoding/Decoding

There are two methods of encoding for remote-control applications:

- Pulse duration encoding (time-extended bit forms): A variable pulse distance, or duration, in which the difference between logic 1 and logic 0 is the length of the pulse width
- Biphase encoding: The encoding of logic 0 and logic 1 is in the change of signal level from 1 to 0 or 0 to 1, respectively.

Japanese manufacturers favor pulse duration encoding; European manufacturers favor biphase encoding.

CIR mode uses a completely flexible free-format encoding in which 1 is transmitted from the TX FIFO as a modulated pulse with duration t .

Similarly, 0 is transmitted as a blank duration T . The Host CPU constructs and deciphers the protocol of the data. For example, the RC-5 protocol using Manchester encoding can be emulated as using a 01 pair for 1 and a 10 pair for 0 (see [Figure 13-71](#)).

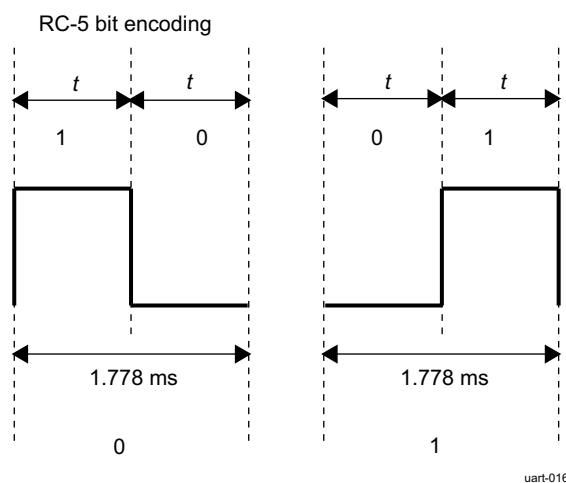

Figure 13-71. UART RC-5 Bit Encoding

Because CIR mode logic does not impose a fixed format for infrared packets of data, the Host CPU software can define the format using simple data structures that are then modulated into an industry standard, such as RC-5 or SIRC. To send a sequence of 0101 in RC-5, the Host CPU software must write an 8-bit binary character of 10011001 to the data FIFO of the UART.

For SIRC, the modulation length (multiples of t) is used to distinguish between 1 and 0. The subsequent SIRC digits show the difference in encoding between this and, for example, RC-5. The pulse width is extended for one digit.

[Figure 13-72](#) shows SIRC bit encoding.

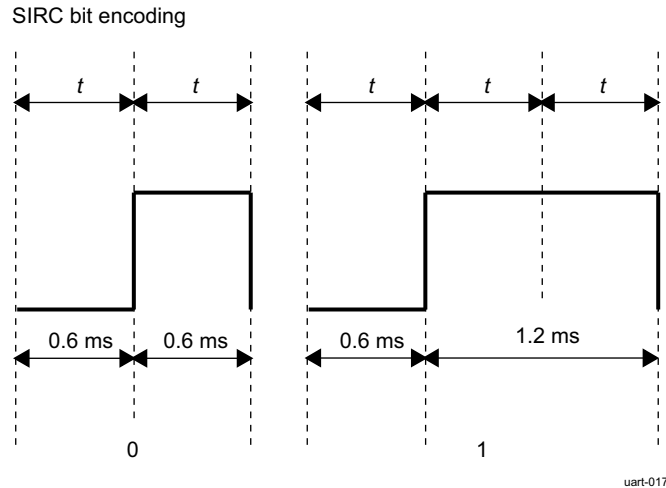
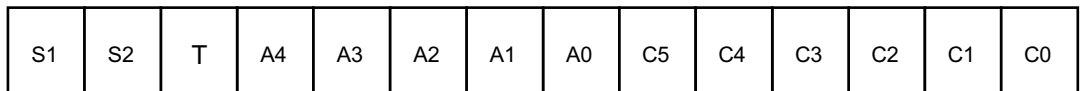

Figure 13-72. UART SIRC Bit Encoding

To construct comprehensive packets constituting remote-control commands, the Host CPU software must combine a number of 8-bit data characters in a sequence that follows one of the universally accepted formats.

Figure 13-73 shows a standard RC-5 frame as detected by UART in CIR mode (the SIRC format follows this). Each field in RC-5 can be considered as two t pulses (digital bits) from the TX FIFO.



uart-018

Figure 13-73. UART RC-5 Standard Packet Format

Where:

- S1, S2: Start-bits (always 1)
- T: Toggle bit
- A4..A0: Address (or system) bits
- C5..C0: Command bits

The toggle bit T changes when a new command is transmitted to detect when the same key is pressed twice (effectively receiving the same data from the host consecutively). A brief delay in the transmission of the same command is detected by the use of the toggle bit because a code is sent while the Host CPU transmits characters to the UART for transmission. The address bits define the machine or device for which the infrared transmission is intended, and the command defines the operation.

To accommodate an extended RC-5 format, the S2 bit is replaced by an additional command bit (C6) that lets the command range increase to 7 bits. This format is known as the extended RC-5 format.

The SIRC encoding uses the duration of modulation for mark and space; therefore, the duration of data bits in the standard frame length varies.

Figure 13-74 shows the packet format and bit encoding. As Figure 13-75 shows, 1 start-bit of 2.4 ms and control codes are followed by data that constitute the entire frame.

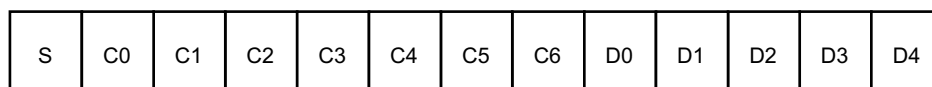

uart-019

Figure 13-74. UART SIRC Packet Format

Note

The encoding must take a standard duration, but the contents of the data can vary. This implies that the control software for sending and receiving data packets must exercise a scheme of interpacket delay, where successive packets can be sent only after a real-time delay expires.

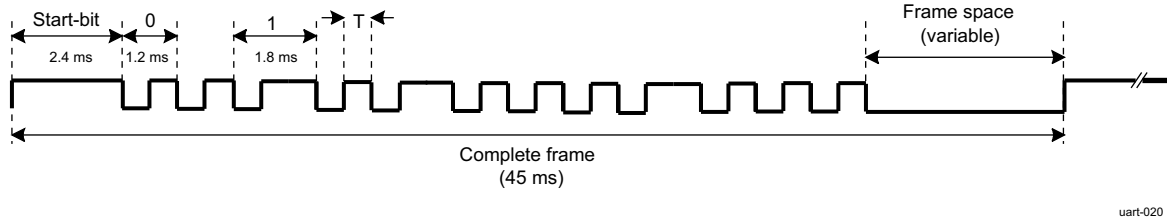

uart-020

Figure 13-75. UART SIRC Bit Transmission Example
Note

This document does not describe all encoding methods and techniques; the previous information discusses the considerations required to employ different encoding methods for different industry-standard protocols. See industry-standard documentation for specific methods of encoding and protocol use.

13.1.4.3 UART Integration

This section describes UART integration in the device, including information about clocks, resets, and hardware requests.

13.1.4.3.1 UART Integration

There are 6x UART modules integrated in the device. The diagram below provides a visual representation of the device integration details.

ADVANCE INFORMATION

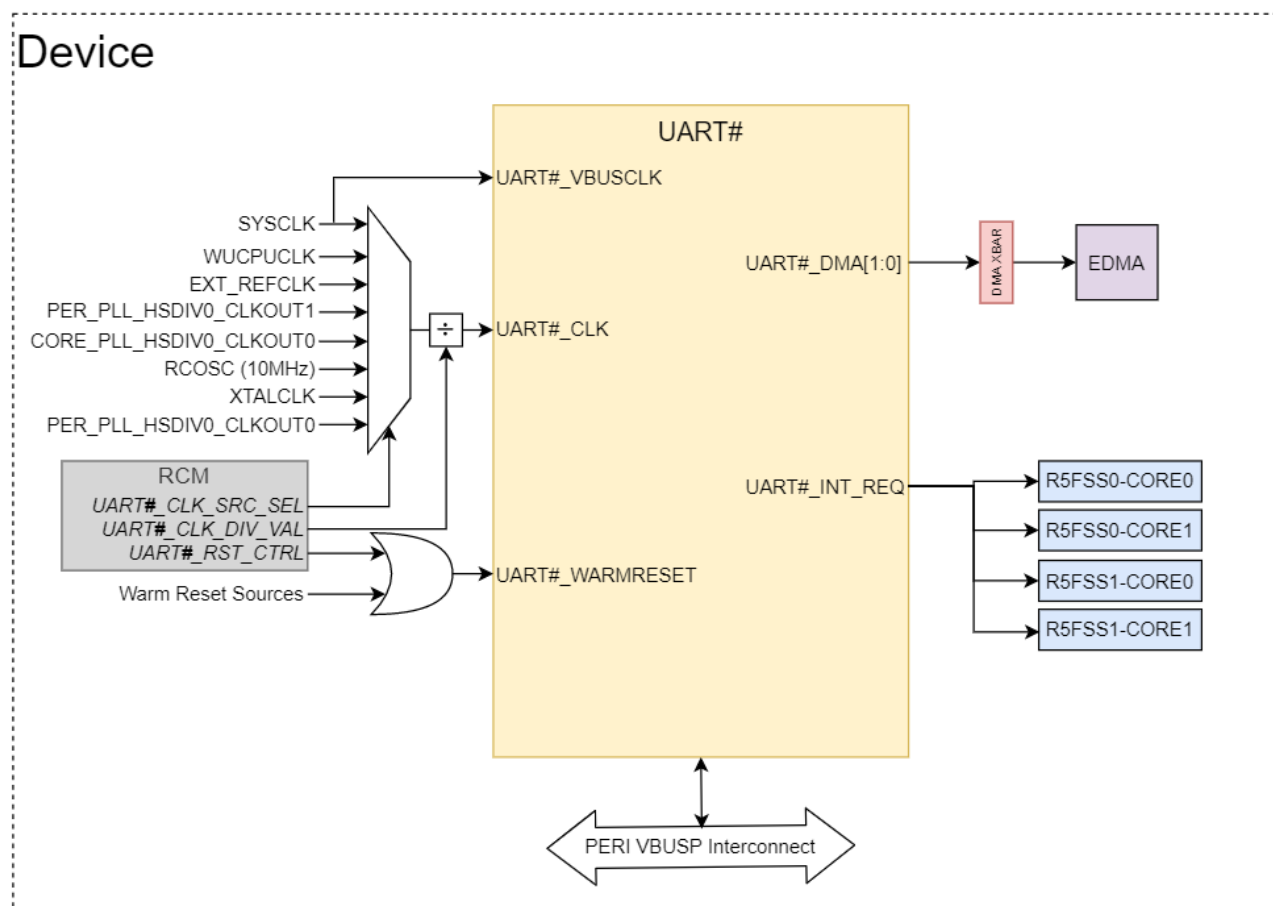

= 0, 1, 2, 3, 4, 5

Figure 13-76. UART Integration

The tables below summarize the device integration details of UART# (where # = 0, 1, 2, 3, 4, 5) in the device.

Table 13-72. UART Device Integration

This table describes the module device integration details.

Module Instance	Device Allocation	SoC Interconnect
UART0	✓	PERI VBUSP Interconnect
UART1	✓	PERI VBUSP Interconnect
UART2	✓	PERI VBUSP Interconnect
UART3	✓	PERI VBUSP Interconnect
UART4	✓	PERI VBUSP Interconnect
UART5	✓	PERI VBUSP Interconnect

Table 13-73. UART Clocks

This table describes the module clocking signals.

Module Instance	Module Clock Input	Source Clock Signal	Source	Default Freq	Description
UART0	UART0_ICLK (VBUSP_CLK)	SYS_CLK	PLL_CORE_CLK: HSDIV0_CLKOUT0	200 MHz	UART0 VBUS Clock
	UART0_FCLK (UART_CLK)	XTALCLK	External XTAL	25 MHz	UART0 Interface Clock
		EXT_REFCLK	External Reference Clock (EXT_REFCLK)	100 MHz	
		SYS_CLK	PLL_CORE_CLK: HSDIV0_CLKOUT0	200 MHz	
		DPLL_PER_HSDIV0_CLK OUT1	PLL_PER_CLK: HSDIV0_CLKOUT1	192 MHz	
		DPLL_CORE_HSDIV0_CLK KOUT0	PLL_CORE_CLK: HSDIV0_CLKOUT0	400 MHz	
		RCCLK10M	Internal 10 MHz RC Oscillator (RCCLK10M)	10 MHz	
		XTALCLK	External XTAL	25 MHz	
DPLL_PER_HSDIV0_CLK OUT0	PLL_PER_CLK:HSDIV0_C LKOUT0	160 MHz			
UART1	UART1_ICLK (VBUSP_CLK)	SYS_CLK	PLL_CORE_CLK: HSDIV0_CLKOUT0	200 MHz	UART1 VBUS Clock
	UART1_FCLK (UART_CLK)	XTALCLK	External XTAL	25 MHz	UART1 Interface Clock
		EXT_REFCLK	External Reference Clock (EXT_REFCLK)	100 MHz	
		SYS_CLK	PLL_CORE_CLK: HSDIV0_CLKOUT0	200 MHz	
		DPLL_PER_HSDIV0_CLK OUT1	PLL_PER_CLK: HSDIV0_CLKOUT1	192 MHz	
		DPLL_CORE_HSDIV0_CLK KOUT0	PLL_CORE_CLK: HSDIV0_CLKOUT0	400 MHz	
		RCCLK10M	Internal 10 MHz RC Oscillator (RCCLK10M)	10 MHz	
		XTALCLK	External XTAL	25 MHz	
DPLL_PER_HSDIV0_CLK OUT0	PLL_PER_CLK:HSDIV0_C LKOUT0	160 MHz			

Table 13-73. UART Clocks (continued)

This table describes the module clocking signals.

Module Instance	Module Clock Input	Source Clock Signal	Source	Default Freq	Description
UART2	UART2_ICLK (VBUSP_CLK)	SYS_CLK	PLL_CORE_CLK: HSDIV0_CLKOUT0	200 MHz	UART2 VBUS Clock
	UART2_FCLK (UART_CLK)	XTALCLK	External XTAL	25 MHz	UART2 Interface Clock
		EXT_REFCLK	External Reference Clock (EXT_REFCLK)	100 MHz	
		SYS_CLK	PLL_CORE_CLK: HSDIV0_CLKOUT0	200 MHz	
		DPLL_PER_HSDIV0_CLK OUT1	PLL_PER_CLK: HSDIV0_CLKOUT1	192 MHz	
		DPLL_CORE_HSDIV0_CLK OUT0	PLL_CORE_CLK: HSDIV0_CLKOUT0	400 MHz	
		RCCLK10M	Internal 10 MHz RC Oscillator (RCCLK10M)	10 MHz	
		XTALCLK	External XTAL	25 MHz	
DPLL_PER_HSDIV0_CLK OUT0	PLL_PER_CLK:HSDIV0_C LKOUT0	160 MHz			
UART3	UART3_ICLK (VBUSP_CLK)	SYS_CLK	PLL_CORE_CLK: HSDIV0_CLKOUT0	200 MHz	UART3 VBUS Clock
	UART3_FCLK (UART_CLK)	XTALCLK	External XTAL	25 MHz	UART3 Interface Clock
		EXT_REFCLK	External Reference Clock (EXT_REFCLK)	100 MHz	
		SYS_CLK	PLL_CORE_CLK: HSDIV0_CLKOUT0	200 MHz	
		DPLL_PER_HSDIV0_CLK OUT1	PLL_PER_CLK: HSDIV0_CLKOUT1	192 MHz	
		DPLL_CORE_HSDIV0_CLK OUT0	PLL_CORE_CLK: HSDIV0_CLKOUT0	400 MHz	
		RCCLK10M	Internal 10 MHz RC Oscillator (RCCLK10M)	10 MHz	
		XTALCLK	External XTAL	25 MHz	
DPLL_PER_HSDIV0_CLK OUT0	PLL_PER_CLK:HSDIV0_C LKOUT0	160 MHz			

ADVANCE INFORMATION

Table 13-73. UART Clocks (continued)

This table describes the module clocking signals.

Module Instance	Module Clock Input	Source Clock Signal	Source	Default Freq	Description
UART4	UART4_ICLK (VBUSP_CLK)	SYS_CLK	PLL_CORE_CLK: HSDIV0_CLKOUT0	200 MHz	UART4 VBUS Clock
	UART4_FCLK (UART_CLK)	XTALCLK	External XTAL	25 MHz	UART4 Interface Clock
		EXT_REFCLK	External Reference Clock (EXT_REFCLK)	100 MHz	
		SYS_CLK	PLL_CORE_CLK: HSDIV0_CLKOUT0	200 MHz	
		DPLL_PER_HSDIV0_CLK OUT1	PLL_PER_CLK: HSDIV0_CLKOUT1	192 MHz	
		DPLL_CORE_HSDIV0_CLK KOUT0	PLL_CORE_CLK: HSDIV0_CLKOUT0	400 MHz	
		RCCLK10M	Internal 10 MHz RC Oscillator (RCCLK10M)	10 MHz	
		XTALCLK	External XTAL	25 MHz	
DPLL_PER_HSDIV0_CLK OUT0	PLL_PER_CLK:HSDIV0_C LKOUT0	160 MHz			
UART5	UART5_ICLK (VBUSP_CLK)	SYS_CLK	PLL_CORE_CLK: HSDIV0_CLKOUT0	200 MHz	UART5 VBUS Clock
	UART5_FCLK (UART_CLK)	XTALCLK	External XTAL	25 MHz	UART5 Interface Clock
		EXT_REFCLK	External Reference Clock (EXT_REFCLK)	100 MHz	
		SYS_CLK	PLL_CORE_CLK: HSDIV0_CLKOUT0	200 MHz	
		DPLL_PER_HSDIV0_CLK OUT1	PLL_PER_CLK: HSDIV0_CLKOUT1	192 MHz	
		DPLL_CORE_HSDIV0_CLK KOUT0	PLL_CORE_CLK: HSDIV0_CLKOUT0	400 MHz	
		RCCLK10M	Internal 10 MHz RC Oscillator (RCCLK10M)	10 MHz	
		XTALCLK	External XTAL	25 MHz	
DPLL_PER_HSDIV0_CLK OUT0	PLL_PER_CLK:HSDIV0_C LKOUT0	160 MHz			

Table 13-74. UART Resets

This table describes the module reset signals.

Module Instance	Module Reset Input	Source Reset Signal	Source	Description
UART0	UART0_RST(VBUSP_RSTn)	Warm Reset (MOD_G_RST)	RCM + Warm Reset Sources	UART0 Asynchronous Reset
UART1	UART1_RST(VBUSP_RSTn)	Warm Reset (MOD_G_RST)	RCM + Warm Reset Sources	UART1 Asynchronous Reset

Table 13-74. UART Resets (continued)

This table describes the module reset signals.

Module Instance	Module Reset Input	Source Reset Signal	Source	Description
UART2	UART2_RST	Warm Reset (MOD_G_RST)	RCM + Warm Reset Sources	UART2 Asynchronous Reset
UART3	UART3_RST	Warm Reset (MOD_G_RST)	RCM + Warm Reset Sources	UART3 Asynchronous Reset
UART4	UART4_RST	Warm Reset (MOD_G_RST)	RCM + Warm Reset Sources	UART4 Asynchronous Reset
UART5	UART5_RST	Warm Reset (MOD_G_RST)	RCM + Warm Reset Sources	UART5 Asynchronous Reset

Table 13-75. UART Interrupt Requests

This table describes the module interrupt requests.

Module Instance	Module Interrupt Signal	Destination Interrupt Input	Destination	Type	Description
UART0	uart0_int_req	uart0_int_req	ALL R5FSS Cores ICSSM Core	Level	UART0 IP Status Information
UART1	uart1_int_req	uart1_int_req	ALL R5FSS Cores ICSSM Core		UART1 IP Status Information
UART2	uart2_int_req	uart2_int_req	ALL R5FSS Cores ICSSM Core		UART2 IP Status Information
UART3	uart3_int_req	uart4_int_req	ALL R5FSS Cores ICSSM Core		UART3 IP Status Information
UART4	uart4_int_req	uart4_int_req	ALL R5FSS Cores ICSSM Core		UART4 IP Status Information
UART5	uart5_int_req	uart5_int_req	ALL R5FSS Cores ICSSM Core		UART5 IP Status Information

Table 13-76. UART DMA Requests

This table describes the module DMA requests.

Module Instance	Module DMA Event	Destination DMA Event Input	Destination	Type	Description
UART0	UART0_DMA_0	UART0_dma_req[0]	EDMA Crossbar (DMA_XBAR)	Level	UART0 DMA Request
	UART0_DMA_1	UART0_dma_req[1]			
UART1	UART1_DMA_0	UART1_dma_req[0]	EDMA Crossbar (DMA_XBAR)	Level	UART1 DMA Request
	UART1_DMA_1	UART1_dma_req[1]			
UART2	UART2_DMA_0	UART2_dma_req[0]	EDMA Crossbar (DMA_XBAR)	Level	UART2 DMA Request
	UART2_DMA_1	UART2_dma_req[1]			
UART3	UART3_DMA_0	UART3_dma_req[0]	EDMA Crossbar (DMA_XBAR)	Level	UART3 DMA Request
	UART3_DMA_1	UART3_dma_req[1]			
UART4	UART4_DMA_0	UART4_dma_req[0]	EDMA Crossbar (DMA_XBAR)	Level	UART4 DMA Request
	UART4_DMA_1	UART4_dma_req[1]			
UART5	UART5_DMA_0	UART5_dma_req[0]	EDMA Crossbar (DMA_XBAR)	Level	UART5 DMA Request
	UART5_DMA_1	UART5_dma_req[1]			

Note

For more information on the interconnects, see the *System Interconnect* chapter.

For more information on power, reset, and clock management, see the corresponding sections within the *Device Configuration* chapter.

For more information on the device interrupt controllers, see the *Interrupt Controllers* chapter.

13.1.4.4 UART Functional Description

13.1.4.4.1 UART Block Diagram

The UART module can be divided into three main blocks:

- FIFO management
- Mode selection
- Protocol formatting

FIFO management is common to all functions and enables the transmission and reception of data from the host processor point of view.

There are two modes:

- Function mode: Routes the data to the chosen function (UART, RS-485, IrDA, or CIR) and enables the mechanism corresponding to the chosen function.
- Register mode: Enables conditional access to registers.

For more information about mode configuration, see [Section 13.1.4.4.7, Mode Selection](#).

Protocol formatting has three subcategories:

- Clock generation: The 48-MHz input clock generates all necessary clocks.
- Data formatting: Each function uses its own state-machine that is responsible for the transition between FIFO data and frame data associated with it.
- Interrupt management: Different interrupt types are generated depending on the chosen function. In each mode, when an interrupt is generated, the UART_IIR_UART register indicates the interrupt type.
 - UART mode interrupts: Seven interrupts prioritized in six different levels
 - IrDA mode interrupts: Eight interrupts. The interrupt line is activated when any interrupt is generated (there is no priority).
 - CIR mode interrupts: A subset of existing IrDA mode interrupts is used.

In parallel with these functional blocks, a power-saving strategy exists for each function.

is the UART block diagram.

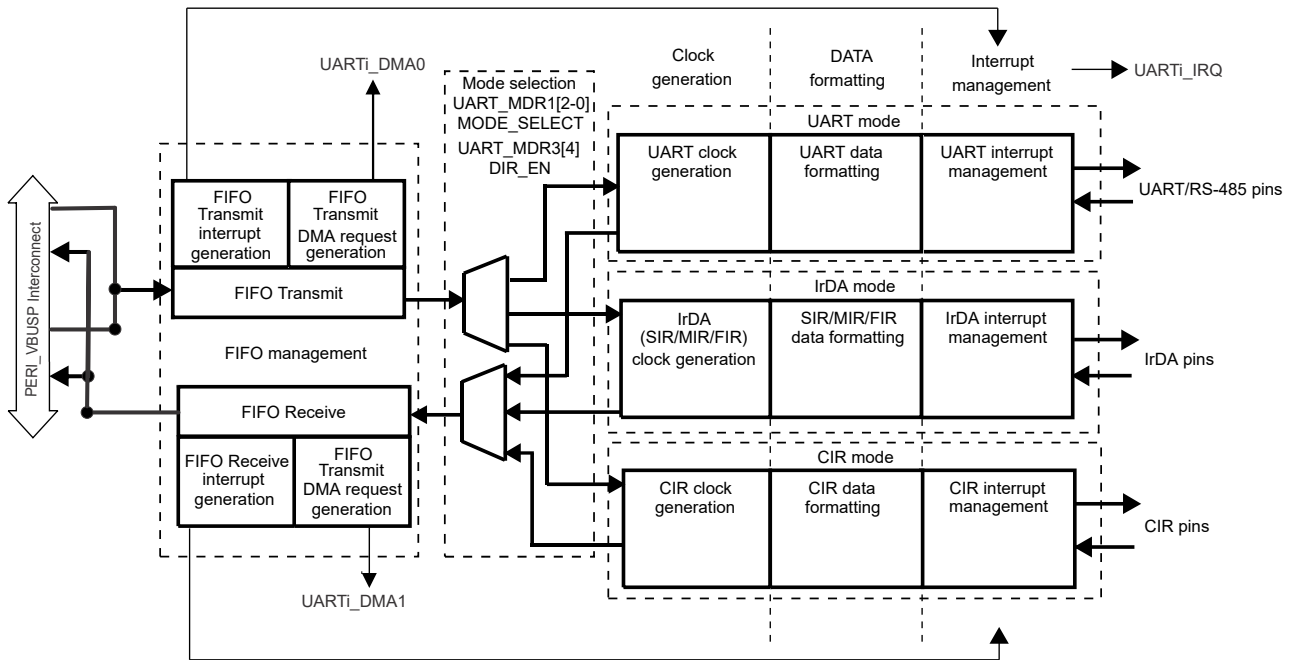

Figure 13-77. UART Functional Block Diagram

13.1.4.4.2 UART Clock Configuration

Each UART uses a 48-MHz functional clock for its logic and to generate external interface signals. Each UART uses an interface clock for register accesses.

13.1.4.4.3 UART Software Reset

The UART_SYSC[1] SOFTRESET bit controls the software reset; setting this bit to 1 triggers a software reset functionally equivalent to hardware reset.

13.1.4.4.3.1 Independent TX/RX

The receiver and transmitter are enabled by default after reset. Software can choose to disable, re-enable or to reset either the RX or the TX side independently of the other through the UART_ECR register.

13.1.4.4.4 UART Power Management

13.1.4.4.4.1 UART Mode Power Management

13.1.4.4.4.1.1 Module Power Saving

In UART modes, sleep mode is enabled by setting the UART_IER_UART[4] SLEEP_MODE bit to 1 (when the UART_EFR[4] ENHANCED_EN bit is set to 1).

Sleep mode is entered when all of the following conditions exist:

- The serial data input line, RX, is idle.
- The TX FIFO and TX shift register are empty.
- The RX FIFO is empty.
- The only pending interrupts are THR interrupts.

Sleep mode is a good way to lower UART power consumption, but this state can be achieved only when the UART is set to modem mode. Therefore, even if the UART has no key role functionally, it must be initialized in a functional mode to take advantage of sleep mode.

In sleep mode, the module clock and baud rate clock are stopped internally. Because most registers are clocked by these clocks, this greatly reduces power consumption. The module wakes up when a change is detected on

the RX line, when data is written to the TX FIFO, and when there is a change in the state of the modem input pins.

An interrupt can be generated on a wake-up event by setting the UART_SCR[4] RX_CTS_WU_EN bit to 1. To understand how to manage the interrupt, see [Section 13.1.4.4.5.1.2, Wake-Up Interrupt](#).

Note

There must be no writing to the divisor latches, UART_DLL and UART_DLH, to set the baud clock (BCLK) while in sleep mode. It is advisable to disable sleep mode using the UART_IER_UART[4] SLEEP_MODE bit before writing to the UART_DLL or UART_DLH register.

13.1.4.4.4.1.2 System Power Saving

Sleep and auto-idle modes are embedded power-saving features. Power-reduction techniques can be applied at the system level by shutting down certain internal clock and power domains of the device.

For more information, see *Power*, in the *Device Configuration*.

13.1.4.4.4.2 IrDA Mode Power Management

13.1.4.4.4.2.1 Module Power Saving

In IrDA modes, sleep mode is enabled by setting the UART_MDR1[3] IR_SLEEP bit to 1.

Sleep mode is entered when all of the following conditions exist:

- The serial data input line, RXD, is idle.
- The TX FIFO and TX shift register are empty.
- The RX FIFO is empty.
- No interrupts are pending except THR interrupts.

The module wakes up when a change is detected on the RXD line or when data is written to the TX FIFO.

13.1.4.4.4.2.2 System Power Saving

System power saving for the IrDA mode has the same function as for the UART mode (see [Section 13.1.4.4.4.1.2, System Power Saving](#)).

13.1.4.4.4.3 CIR Mode Power Management

13.1.4.4.4.3.1 Module Power Saving

Module power saving for the CIR mode has the same function as for the IrDA mode (see [Section 13.1.4.4.4.2.1, Module Power Saving](#)).

13.1.4.4.4.3.2 System Power Saving

System power saving for the CIR mode has the same function as for the UART mode (see [Section 13.1.4.4.4.1.2, System Power Saving](#)).

13.1.4.4.4.4 Local Power Management

[Table 13-77](#) describes power-management features available for the UART.

Note

For information about source clock gating and the sleep/wake-up transitions description, see *Power*, in the *Device Configuration*.

Table 13-77. UART Local Power-Management Features

Feature	Registers	Description
Clock autogating	N/A	Feature not available
Peripheral idle modes	N/A	Feature not available
Clock activity	N/A	Feature not available

Table 13-77. UART Local Power-Management Features (continued)

Feature	Registers	Description
Controller standby modes	N/A	Feature not available
Global wake-up enable	UART_SYSC[2] ENAWAKEUP	This bit enables the wake-up feature at module level.
Wake-Up sources enable	N/A	Feature not available

13.1.4.4.5 UART Interrupt Requests

13.1.4.4.5.1 UART Mode Interrupt Management

13.1.4.4.5.1.1 UART Interrupts

The UART mode includes seven possible interrupts prioritized to six levels.

When an interrupt is generated, the interrupt identification register (UART_IIR_UART) sets the UART_IIR_UART[0] IT_PENDING bit to 0 to indicate that an interrupt is pending, and indicates the type of interrupt through the UART_IIR_UART[5-1] bit field. [Table 13-78](#) summarizes the interrupt control functions.

Table 13-78. UART Mode Interrupts

IIR[5:0]	Priority Level	Interrupt Type	Interrupt Source	Interrupt Reset Method
000001	N/A	No Interrupt	N/A	N/A
000110	1	Receiver line status	OE, FE, PE, or BI errors occur in characters in the RX FIFO.	FE, PE, BI: Read the UART_RHR register. OE: Read the UART_LSR_UART register.
001100	2	RX time-out	Stale data in RX FIFO	Read the UART_RHR register.
000100	2	RHR interrupt	DRDY (data ready) (FIFO disabled) RX FIFO above trigger level (FIFO enabled)	Read the UART_RHR register until the interrupt condition disappears
000010	3	THR interrupt	TFE (THR empty) (FIFO disabled) TX FIFO below trigger level (FIFO enabled)	Write to the UART_THR until the interrupt condition disappears
000000	4	Modem status	See the UART_MSR register.	Read the MSR register
010000	5	XOFF interrupt/ special character interrupt	Receive XOFF characters/special character	Receive XON character(s), if XOFF interrupt/read of the UART_IIR_UART register, if special character interrupt
100000	6	CTS, RTS	RTS pin or CTS pin change state from active (low) to inactive (high)	Read the UART_IIR_UART register

For the receiver-line status interrupt, the UART_LSR_UART[7] RX_FIFO_STS bit generates the interrupt.

For the XOFF interrupt, if an XOFF flow character detection caused the interrupt, the interrupt is cleared by an XON flow character detection. If special character detection caused the interrupt, the interrupt is cleared by a read of the UART_IIR_UART register.

13.1.4.4.5.1.2 Wake-Up Interrupt

Wake-up interrupt is a special interrupt that works differently from other interrupts. This interrupt is enabled when the UART_SCR[4] RX_CTS_WU_EN bit is set to 1. The UART_IIR_UART register is not modified when this occurs; the UART_SSR[1] RX_CTS_WU_STS bit must be checked to detect a wake-up event.

When a wake-up interrupt occurs, it can be cleared only by resetting the UART_SCR[4] RX_CTS_WU_EN bit. This bit must be reenabled (set to 1) after the current wake-up interrupt event is processed to detect the next incoming wake-up event.

13.1.4.4.5.2 IrDA Mode Interrupt Management

13.1.4.4.5.2.1 IrDA Interrupts

The IrDA function generates interrupts. All interrupts can be enabled and disabled by writing to the appropriate bit in the interrupt enable register (UART_IER_IRDA). The interrupt status of the device can be checked by reading the interrupt identification register (UART_IIR_IRDA).

The UART, IrDA, and CIR modes have different interrupts in the UART module and, therefore, different UART_IER_IRDA and UART_IIR_IRDA mappings, depending on the selected mode.

The IrDA modes have eight possible interrupts (see [Table 13-79](#)). The interrupt line is activated when any interrupt is generated (there is no priority).

Table 13-79. IrDA Mode Interrupts

IIR_IRDA Bit	Interrupt Type	Interrupt Source	Interrupt Reset Method
0	RHR interrupt	DRDY (data ready) (FIFO disabled) RX FIFO above trigger level (FIFO enabled)	Read the UART_RHR register until the interrupt condition disappears.
1	THR interrupt	TFE (UART_THR empty) (FIFO disabled) TX FIFO below trigger level (FIFO enabled)	Write to the UART_THR until the interrupt condition disappears.
2	Last byte in RX FIFO	Last byte of frame in RX FIFO is available to be read at the UART_RHR port.	Read the UART_RHR register.
3	RX overrun	Write to the UART_RHR register when the RX FIFO is full.	Read UART_RESUME register.
4	Status FIFO interrupt	Status FIFO triggers level reached.	Read STATUS FIFO.
5	TX status	UART_THR empty before EOF sent. Last bit of transmission of the IrDA frame occurred, but with an underrun error OR Transmission of the last bit of the IrDA frame completed successfully.	Read the UART_RESUME register OR Read the UART_IIR_IRDA register.
6	Receiver line status interrupt	CRC, ABORT, or frame-length error is written into the STATUS FIFO.	Read the STATUS FIFO (read until empty - maximum of eight reads required).
7	Received EOF	Received end-of-frame	Read the UART_IIR_IRDA register.

13.1.4.4.5.2.2 Wake-Up Interrupts

The wake-up interrupt for IrDA mode has the same function as that for UART mode (see [Section 13.1.4.4.5.1.2, Wake-Up Interrupt](#)).

13.1.4.4.5.3 CIR Mode Interrupt Management

13.1.4.4.5.3.1 CIR Interrupts

The CIR function generates interrupts that can be enabled and disabled by writing to the appropriate bit in the interrupt enable register (UART_IER_CIR). The interrupt status of the device can be checked by reading the interrupt identification register (UART_IIR_CIR).

The UART, IrDA, and CIR modes have different interrupts in the UART module and, therefore, different UART_IER_CIR and UART_IIR_CIR mappings, depending on the selected mode.

[Table 13-80](#) lists the interrupt modes to be maintained. In CIR mode, the sole purpose of the UART_IIR_CIR[5] TX_STATUS_IT bit is to indicate that the last bit of infrared data was passed to the TX pin.

Table 13-80. CIR Mode Interrupts

IIR_CIR Bit Number	Interrupt Type	Interrupt Source	Interrupt Reset Method
0	RHR interrupt	DRDY (data ready) (FIFO disable) RX FIFO above trigger level (FIFO enable)	Read RHR until interrupt condition disappears.
1	THR interrupt	TFE (THR empty) (FIFO disabled) TX FIFO below trigger level (FIFO enabled)	Write to the UART_THR register until the interrupt condition disappears
2	RX_STOP_IT	Receive stop interrupt (depending on value set in the BOF Length register (EBLR))	Read the UART_IIR_CIR register

Table 13-80. CIR Mode Interrupts (continued)

IIR_CIR Bit Number	Interrupt Type	Interrupt Source	Interrupt Reset Method
3	RX overrun	Write to RHR when RX FIFO is full.	Read the RESUME register.
4	N/A for CIR mode	N/A for CIR mode	N/A for CIR mode
5	TX status	Transmission of the last bit of the frame is complete successfully	Read the UART_IIR_CIR register
6	N/A for CIR mode	N/A for CIR mode	N/A for CIR mode
7	N/A for CIR mode	N/A for CIR mode	N/A for CIR mode

13.1.4.4.5.3.2 Wake-Up Interrupts

The wake-up interrupt for CIR mode has the same function as that for UART mode (see [Section 13.1.4.4.5.1.2, Wake-Up Interrupt](#)).

13.1.4.4.6 UART FIFO Management

The FIFO is accessed by reading and writing the UART_RHR and UART_THR registers. Parameters are controlled using the FIFO control register (UART_FCR) and supplementary control register (UART_SCR). Reading the UART_SSR[0] TX_FIFO_FULL bit at 1 means the FIFO is full.

The UART_TLR register controls the FIFO trigger level, which enables DMA and interrupt generation. After reset, transmit (TX) and receive (RX) FIFOs are disabled; thus, the trigger level is the default value of 1 byte. [Figure 13-78](#) shows the FIFO management registers.

Note

Data in the UART_RHR register is not overwritten when an overflow occurs.

Note

The UART_SFLSR, UART_SFREGL, and UART_SFREGH status registers are used in IrDA mode only. For information about their use, see [Section 13.1.4.4.8.3.3, IrDA Data Formatting](#).

Note

Bits UART_FCR[2] TX_FIFO_CLEAR and UART_FCR[1] RX_FIFO_CLEAR are automatically cleared by hardware after $4 \times + 5 \times \text{UART}_i\text{FCLK}$ clock cycles. This delay is needed to finish the resetting of the corresponding FIFO and DMA control registers.

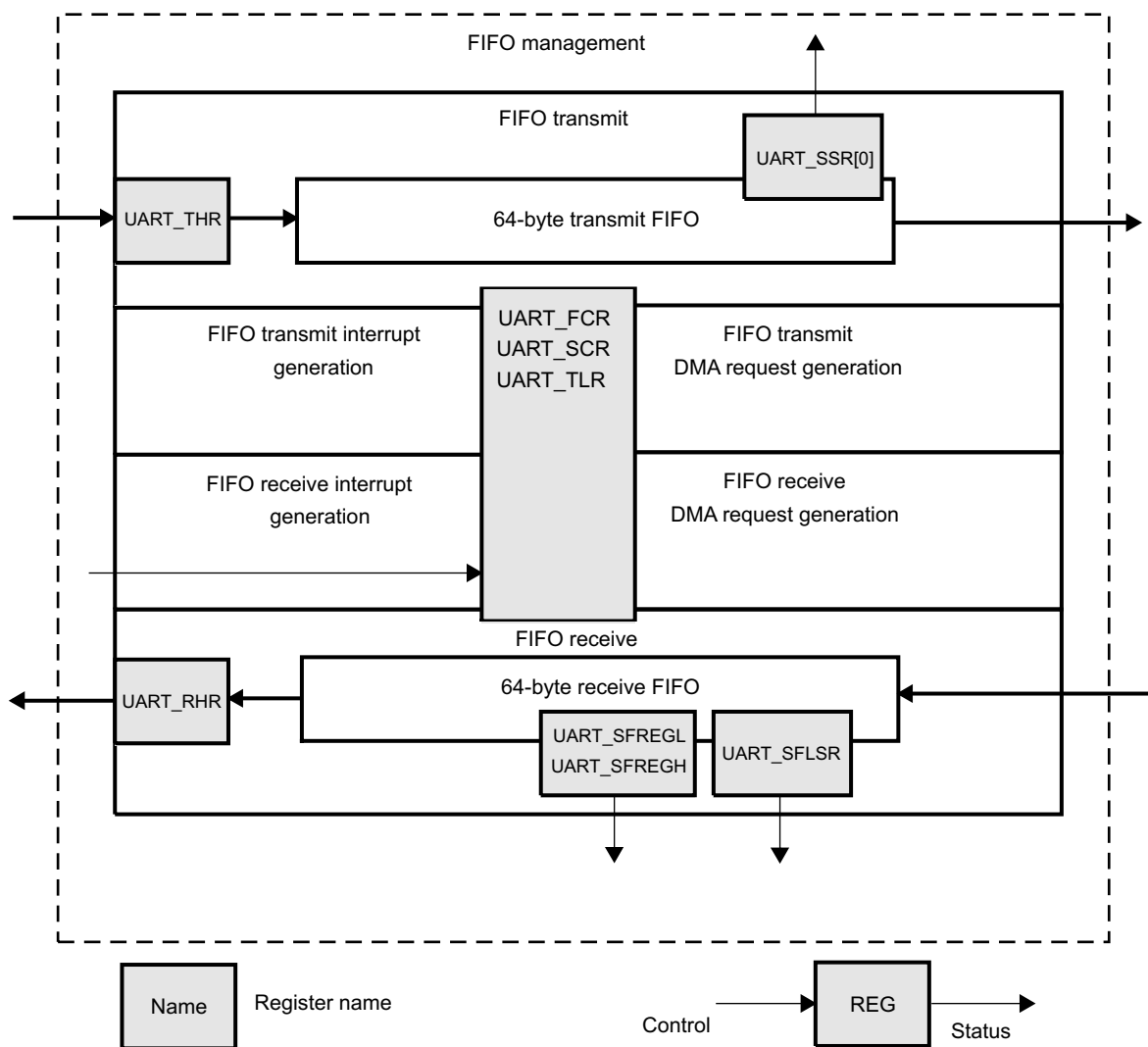

uart-023

Figure 13-78. UART FIFO Management Registers

13.1.4.4.6.1 FIFO Trigger

13.1.4.4.6.1.1 Transmit FIFO Trigger

Table 13-81 lists the TX FIFO trigger level settings.

Table 13-81. UART TX FIFO Trigger Level Setting Summary

SCR[6]	TLR[3:0]	TX FIFO Trigger Level
0	= 0x0	Defined by the UART_FCR[5-4] TX_FIFO_TRIG bit field (8, 16, 32, or 56 spaces)
0	!= 0x0	Defined by the UART_TLR[3-0] TX_FIFO_TRIG_DMA bit field (from 4 to 60 spaces with a granularity of 4 spaces)
1	Value	Defined by the concatenated value of TX_FIFO_TRIG_DMA and TX_FIFO_TRIG (from 1 to 63 spaces with a granularity of 1 space)

Note: The combination of TX_FIFO_TRIG_DMA = 0x0 and TX_FIFO_TRIG = 0x0 (all zeros) is not supported (minimum of 1 space required). All zeros result in unpredictable behavior.

13.1.4.4.6.1.2 Receive FIFO Trigger

Table 13-82 lists the RX FIFO trigger-level settings.

Table 13-82. UART RX FIFO Trigger-Level Setting Summary

SCR[7]	TLR[7:4]	RX FIFO Trigger Level
0	= 0x0	Defined by the UART_FCR[7-6] RX_FIFO_TRIG bit field (8, 16, 56, or 60 characters)
0	!= 0x0	Defined by the UART_TLR[7-4] RX_FIFO_TRIG_DMA bit field (from 4 to 60 characters with a granularity of 4 characters)
1	Value	Defined by the concatenated value of RX_FIFO_TRIG_DMA and RX_FIFO_TRIG (from 1 to 63 characters with a granularity of 1 character) Note: The combination of RX_FIFO_TRIG_DMA = 0x0 and RX_FIFO_TRIG = 0x0 (all zeros) is not supported (minimum of 1 character required). All zeros result in unpredictable behavior.

The receive threshold is programmed using the UART_TCR[7-4] RX_FIFO_TRIG_START and UART_TCR[3-0] RX_FIFO_TRIG_HALT bit fields:

- Trigger levels from 0 to 60 bytes are available with a granularity of 4 (trigger level = 4 × [4-bit register value]).
- To ensure correct device operation, ensure that RX_FIFO_TRIG_HALT > RX_FIFO_TRIG when auto-RTS is enabled.

$$\text{Delay} = [4 + 16 \times (1 + \text{CHAR_LENGTH} + \text{Parity} + \text{Stop} - 0.5)] \times \text{Baud_rate} + 4 \times \text{FCLK}$$

Note

The RTS signal is deasserted after the UART module receives the data over RX_FIFO_TRIG_HALT. Delay means how long the UART module takes to deassert the RTS signal after reaching RX_FIFO_TRIG_HALT.

- In FIFO interrupt mode with flow control, ensure that the trigger level to HALT transmission is greater than or equal to the RX FIFO trigger level (the UART_TCR[7-4] RX_FIFO_TRIG_START bit field or the UART_FCR[7-6] RX_FIFO_TRIG bit field); otherwise, FIFO operation stalls. In FIFO DMA mode with flow control, this concept does not exist, because a DMA request is sent when a byte is received.

13.1.4.4.6.2 FIFO Interrupt Mode

In FIFO interrupt mode (the FIFO control register UART_FCR[0] FIFO_EN bit is set to 1 and relevant interrupts are enabled by the UART_IER_UART register), an interrupt signal informs the processor of the status of the receiver and transmitter. These interrupts are raised when the RX/TX FIFO threshold (the UART_TLR[7-4] RX_FIFO_TRIG_DMA and UART_TLR[3-0] TX_FIFO_TRIG_DMA bit fields or the UART_FCR[7-6] RX_FIFO_TRIG and UART_FCR[5-4] TX_FIFO_TRIG bit fields, respectively) is reached.

The interrupt signals instruct the Host CPU to transfer data to the destination (from the UART in receive mode and/or from any source to the UART FIFO in transmit mode).

When UART flow control is enabled with interrupt capabilities, the UART flow control FIFO threshold (the UART_TCR[3-0] RX_FIFO_TRIG_HALT bit field) must be greater than or equal to the RX FIFO threshold.

Figure 13-79 shows the generation of the RX FIFO interrupt request.

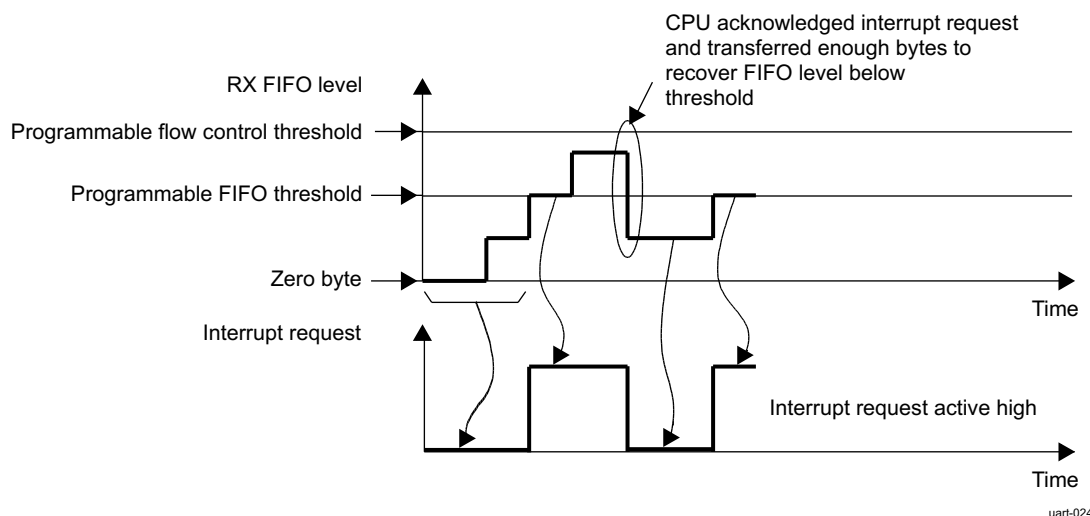

Figure 13-79. UART RX FIFO Interrupt Request Generation

In receive mode, no interrupt is generated until the RX FIFO reaches its threshold. Once low, the interrupt can be deasserted only when the Host CPU has handled enough bytes to put the FIFO level below threshold. The flow control threshold is set at a higher value than the FIFO threshold.

Figure 13-80 shows the generation of the TX FIFO interrupt request.

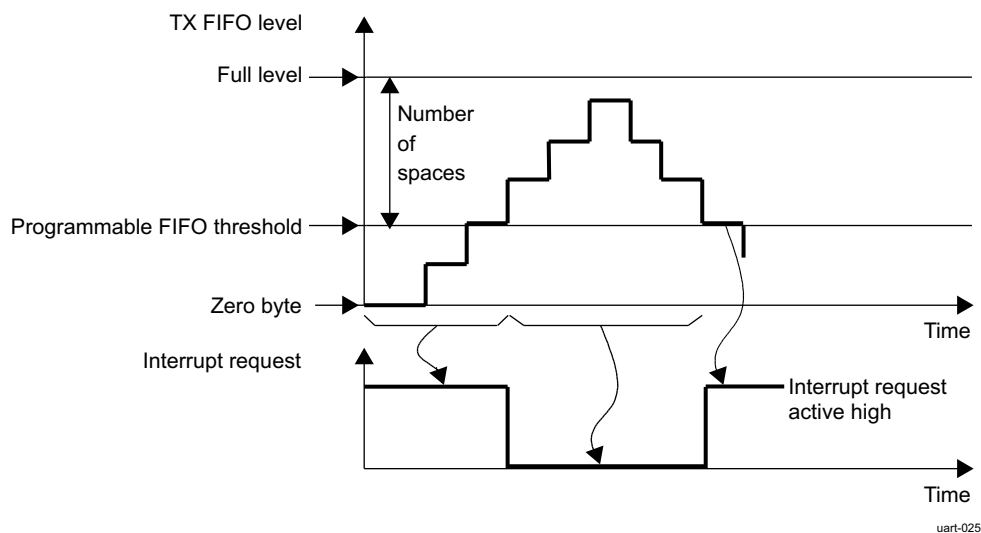

Figure 13-80. UART TX FIFO Interrupt Request Generation

In transmit mode, an interrupt request is automatically asserted when the TX FIFO is empty. This request is deasserted when the TX FIFO crosses the threshold level. The interrupt line is deasserted until a sufficient number of elements is transmitted to go below the TX FIFO threshold.

13.1.4.4.6.3 FIFO Polled Mode Operation

In FIFO polled mode (the UART_FCR[0] FIFO_EN bit is set to 0 and the relevant interrupts are disabled by the UART_IER_UART register), the status of the receiver and transmitter can be checked by polling the line status register (UART_LSR_UART).

This mode is an alternative to the FIFO interrupt mode of operation in which the status of the receiver and transmitter is automatically determined by sending interrupts to the Host CPU.

13.1.4.4.6.4 FIFO DMA Mode Operation

Although the DMA operation includes four modes (DMA modes 0 through 3), the information in , *UART Hardware Requests*, assumes that mode 1 is used. (Mode 2 and mode 3 are legacy modes that use only one DMA request for each module.)

In mode 2, the remaining DMA request is used for RX. In mode 3, the remaining DMA request is used for TX.

DMA requests in mode 2 and mode 3 use the USART_i_DMA0 signals (where i = 0 to 5).

signals are not used by the module in mode 2 and mode 3:

The DMA mode and signals usage can be selected as follows:

- When the UART_SCR[0] DMA_MODE_CTL bit is set to 0, setting the UART_FCR[3] DMA_MODE bit to 0 enables DMA mode 0. Setting the UART_FCR[3] DMA_MODE bit to 1 enables DMA mode 1.
- When the UART_SCR[0] DMA_MODE_CTL bit is set to 1, the UART_SCR[2-1] DMA_MODE_2 bit field determines DMA mode 0 to mode 3 based on the supplementary control register (UART_SCR) description.

For example:

- If no DMA operation is desired, set the UART_SCR[0] DMA_MODE_CTL bit to 1 and the UART_SCR[2-1] DMA_MODE_2 bit field to 0x0. (The DMA_MODE bit is discarded.)
- If DMA mode 1 is desired, set the UART_SCR[0] DMA_MODE_CTL bit to 0 and the UART_FCR[3] DMA_MODE bit to 1, or set the UART_SCR[0] DMA_MODE_CTL bit to 1 and the UART_SCR[2-1] DMA_MODE_2 bit field to 01. (The UART_FCR[3] DMA_MODE bit is discarded.)

If the FIFOs are disabled (the UART_FCR[0] FIFO_EN bit is set to 0), the DMA occurs in single-character transfers.

When DMA mode 0 is programmed, the signals associated with DMA operation are not active.

Depending on UART_MDR3[2] SET_DMA_TX_THRESHOLD, the threshold can be programmed different ways:

- SET_TX_DMA_THRESHOLD = 1:
The threshold value will be the value of the UART_TX_DMA_THRESHOLD register. If SET_TX_DMA_THRESHOLD + TX trigger spaces 64, then the default method of threshold is used: threshold value = TX FIFO size.
- SET_TX_DMA_THRESHOLD = 0:
The threshold value = TX FIFO size TX trigger space. The TX DMA line is asserted if the TX FIFO level is lower then the threshold. It remains asserted until TX trigger spaces number of bytes are written into the FIFO. The DMA line is then deasserted and the FIFO level is compared with the threshold value.

13.1.4.4.6.4.1 DMA sequence to disable TX DMA

In order to disable TX DMA if it is not needed anymore (e.g. all transfers are done and UART idle mode is desired), the following sequence must be use

1. DMA mode 1 is set (both TX/RX DMA) by registers UART_SCR[0] DMA_MODE_CTL = 0 and UART_FCR[3] DMA_MODE = 1:
 - a. Set the UART_SCR[2-1] DMA_MODE_2 bit fields to 01 (DMA mode 1)
 - b. Set the UART_SCR[0] DMA_MODE_CTL bit to 1 (this setting of UART_SCR[0] DMA_MODE-CTL will ignores UART_FCR[3] DMA_MODE_CTL bit)

Note

It is strongly suggested to do steps 'a' and 'b' in two separate write in order to avoid malfunction of the device.

- c. Set the UART_FCR[3] DMA_MODE bit to 0. It is not necessary but suggested to avoid restore of DMA mode 1 during accidental reset of UART_SCR[0] DMA_MODE_CTL bit. Be sure that all data was read out from RX FIFO and if it possible disable the RX side. In UART mode the RTS/CTS or XOFF/XON

protocol can be used. In IrDA modes RX can be forcibly disabled by setting UART_ACREG[5] DIS_IR_RX bit

Note

There can be RX DATA loss during the next steps if all DATA was not read out or there was an ongoing reception!

- d. Set the UART_FCR[2-1] DMA_MODE bit field to 11 (clear TX and RX FIFO and resets its counter logic to 0. Returns to 0 after clearing FIFO).
- e. Set the UART_SCR[2-1] DMA_MODE_2 bit field to 10 (DMA mode 2, RX only).
- f. Set the UART_FCR[2-1] DMA_MODE bit field to 11 (clear TX and RX FIFO and the DMA request again).
- g. Set the UART_SCR[2-1] DMA_MODE_2 bit field to 00 (no DMA) or keep 10 if RX DMA is needed.
2. DMA mode 1 is set (both TX/RX DMA) by registers UART_FCR[3] DMA_MODE = 0 and UART_SCR[0] DMA_MODE_CTL = 1, UART_SCR[2-1] DMA_MODE_2 = 01. It is almost the same as above, but steps 'a', and 'b' can be skipped:
 - a. Set the UART_FCR[3] DMA_MODE bit to 0. It is not necessary but suggested to avoid restore of DMA mode 1 during accidental reset of UART_SCR[0] DMA_MODE_CTL bit. Be sure that all data was read out from RX FIFO and if it possible disable the RX side. In UART mode the RTS/CTS or XOFF/XON protocol can be used. In IrDA modes RX can be forcibly disabled by setting UART_ACREG[5] DIS_IR_RX bit

Note

There can be RX DATA loss during the next steps if all DATA was not read out or there was an ongoing reception!

- b. Set the UART_FCR[2-1] DMA_MODE bit field to 11 (clear TX and RX FIFO and resets its counter logic to 0. Returns to 0 after clearing FIFO).
- c. Set the UART_SCR[2-1] DMA_MODE_2 bit field to 10 (DMA mode 2, RX only).
- d. Set the UART_FCR[2-1] DMA_MODE bit field to 11 (clear TX and RX FIFO and the DMA request again).
- e. Set the UART_SCR[2-1] DMA_MODE_2 bit field to 00 (no DMA) or keep 10 if RX DMA is needed.
3. DMA mode 3 is set (TX DMA only) by registers UART_FCR[3] DMA_MODE = 0 and UART_SCR[0] DMA_MODE_CTL = 1, UART_SCR[2-1] DMA_MODE_2 = 11. It is the same as above:
 - a. Set the UART_FCR[3] DMA_MODE bit to 0. It is not necessary but suggested to avoid restore of DMA mode 1 during accidental reset of UART_SCR[0] DMA_MODE_CTL bit. Be sure that all data was read out from RX FIFO and if it possible disable the RX side. In UART mode the RTS/CTS or XOFF/XON protocol can be used. In IrDA modes RX can be forcibly disabled by setting UART_ACREG[5] DIS_IR_RX bit

Note

There can be RX DATA loss during the next steps if all DATA was not read out or there was an ongoing reception!

- b. Set the UART_FCR[2-1] DMA_MODE bit field to 11 (clear TX and RX FIFO and resets its counter logic to 0. Returns to 0 after clearing FIFO).
- c. Set the UART_SCR[2-1] DMA_MODE_2 bit field to 10 (DMA mode 2, RX only).
- d. Set the UART_FCR[2-1] DMA_MODE bit field to 11 (clear TX and RX FIFO and the DMA request again).
- e. Set the UART_SCR[2-1] DMA_MODE_2 bit field to 00 (no DMA) or keep 10 if RX DMA is needed.

13.1.4.4.6.4.2 DMA Transfers (DMA Mode 1, 2, or 3)

Figure 13-81 through Figure 13-84 show the supported DMA operations.

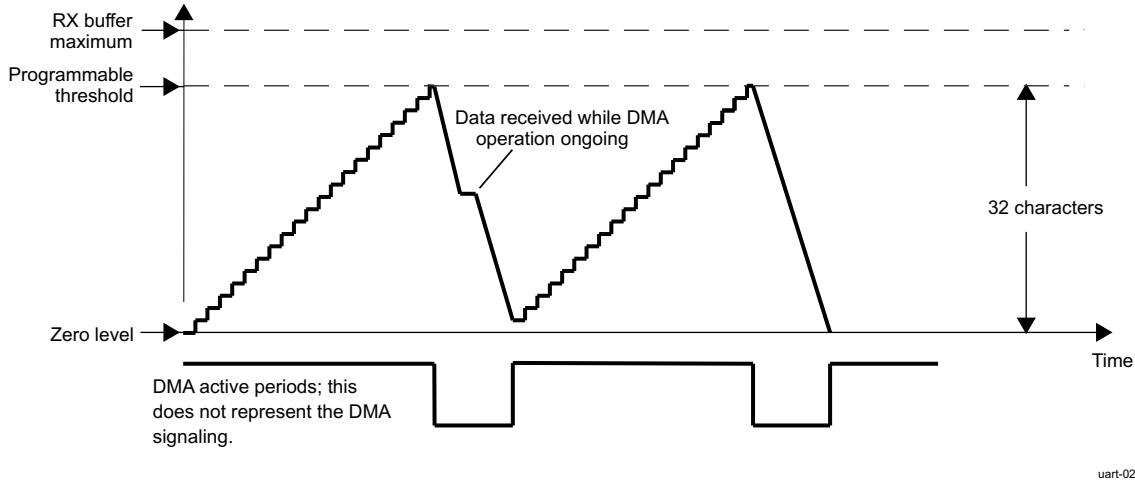

Figure 13-81. UART Receive FIFO DMA Request Generation (32 Characters)

In receive mode, a DMA request is generated when the RX FIFO reaches its threshold level defined in the trigger level register (UART_TLR). This request is deasserted when the number of bytes defined by the threshold level is read by the device DMA controllers.

In transmit mode, a DMA request is automatically asserted when the TX FIFO is empty. This request is deasserted when the number of bytes defined by the number of spaces in the UART_TLR register is written by the device DMA controllers. If an insufficient number of characters is written, the DMA request stays active.

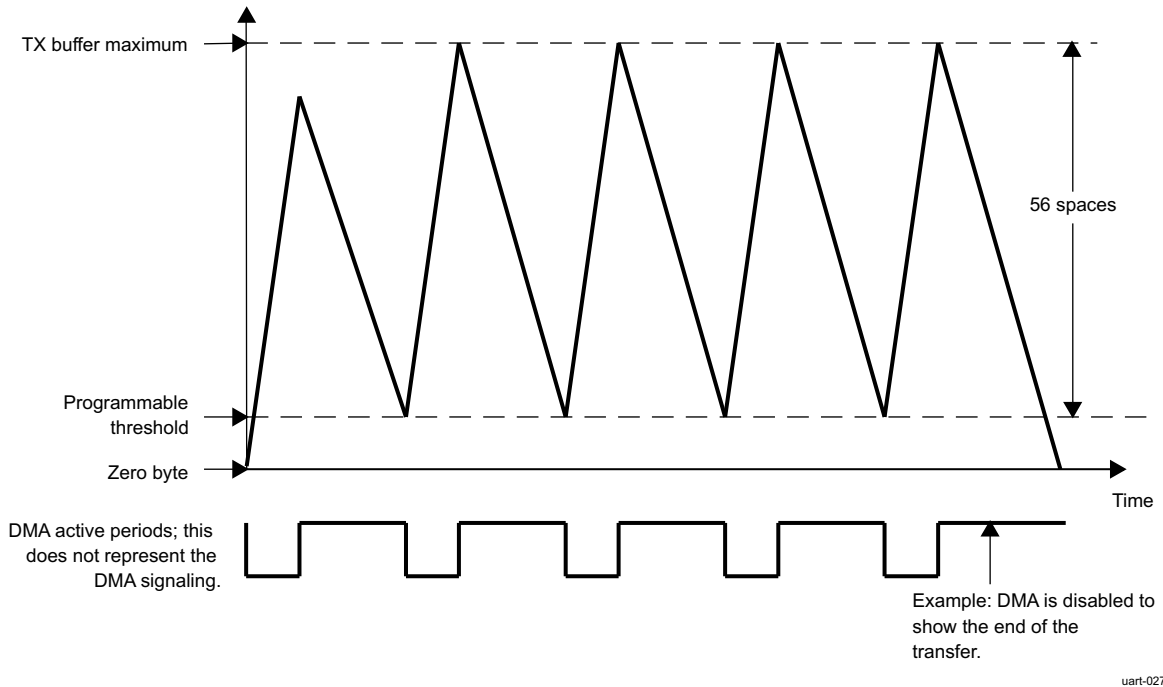

Figure 13-82. UART Transmit FIFO DMA Request Generation (56 Spaces)

The DMA request is again asserted if the FIFO can receive the number of bytes defined by the UART_TLR register.

The threshold can be programmed in a number of ways. Figure 13-82 shows a DMA transfer operating with a space setting of 56 that can arise from using the auto settings in the UART_FCR[5-4] TX_FIFO_TRIG bit field or the UART_TLR[3-0] TX_FIFO_TRIG_DMA bit field concatenated with the TX_FIFO_TRIG bit field.

The setting of 56 spaces in the UART module must correlate with the settings of the device DMA controllers, so that the buffer does not overflow (program the DMA request size of the LH controller to equal the number of spaces in the UART module).

Figure 13-83 shows an example with eight spaces to show the buffer level crossing the space threshold. The LH DMA controller settings must correspond to those of the UART module.

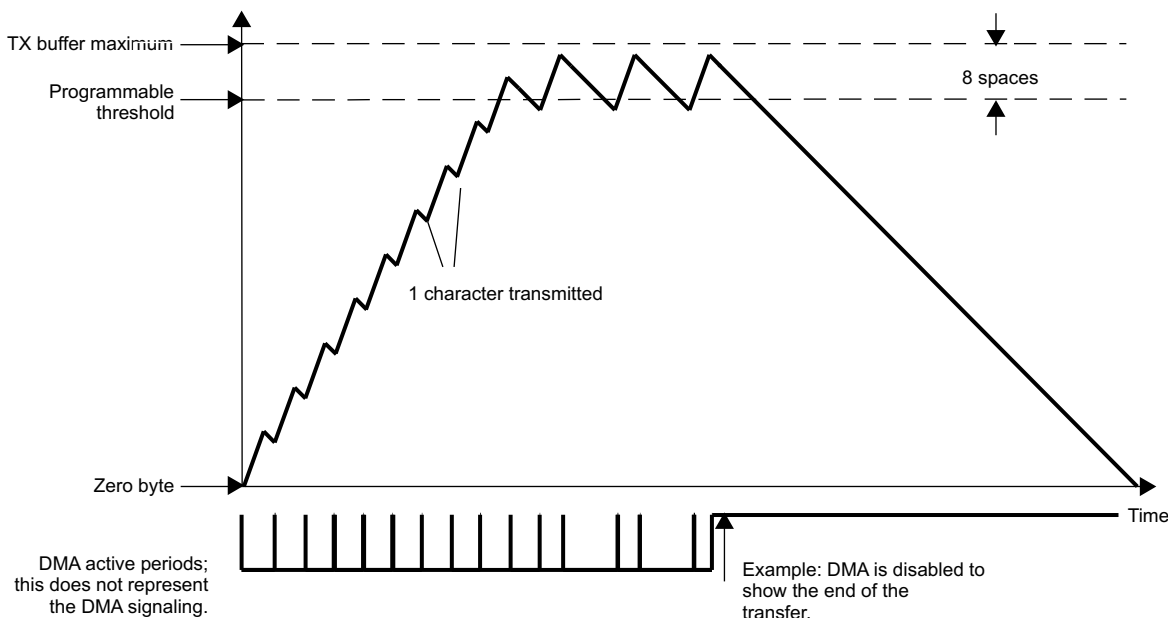

uart-028

Figure 13-83. UART Transmit FIFO DMA Request Generation (8 Spaces)

The next example shows the setting of one space that uses the DMA for each transfer of one character to the transmit buffer (see Figure 13-84). The buffer is filled faster than the baud rate at which data is transmitted to the TX pin. Eventually, the buffer is completely full and the DMA operations stop transferring data to the transmit buffer.

On two occasions, the buffer holds the maximum amount of data words; shortly after this, the DMA is disabled to show the slower transmission of the data words to the TX pin. Eventually, the buffer is emptied at the rate specified by the baud rate settings of the UART_DLL and UART_DLH registers.

The DMA settings must correspond to the system LH DMA controller settings to ensure correct operation of this logic.

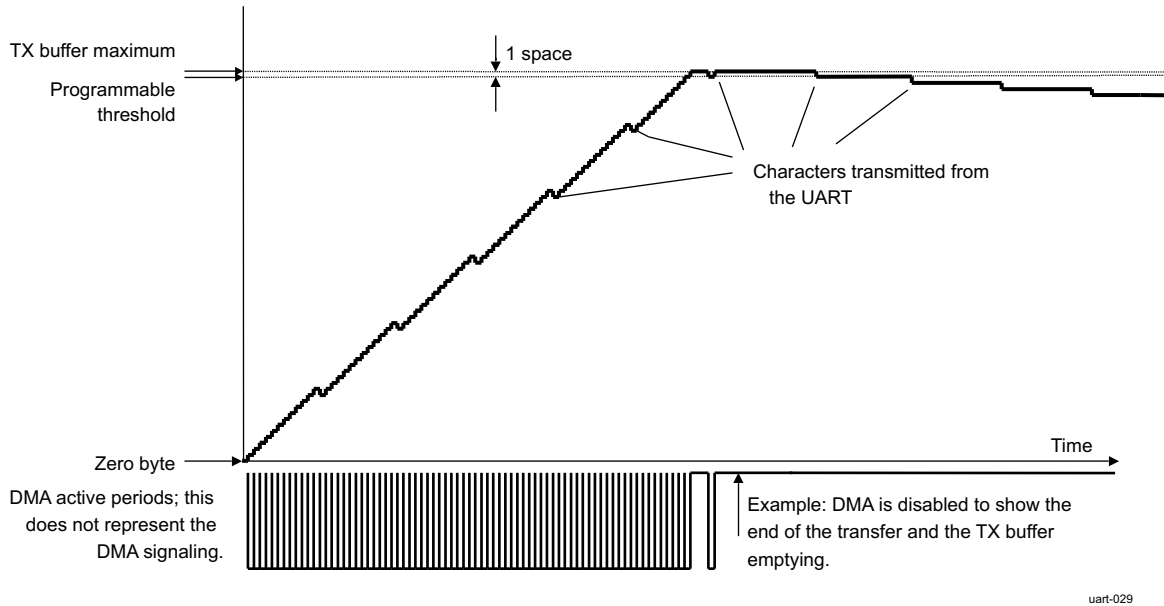

Figure 13-84. UART Transmit FIFO DMA Request Generation (1 Space)

The final example illustrates the setting of eight spaces but setting the TX DMA threshold directly by setting UART_MDR3[1] NONDEFAULT_FREQ bit and UART_TX_DMA_THRESHOLD register (see [Figure 13-85](#)). In the example, the UART_TX_DMA_THRESHOLD[5-0] TX_DMA_THRESHOLD = 3 and the trigger level is 8. The buffer is filled at a faster rate than the BAUD rate transmits data to the TX pin. The buffer is filled with 8 bytes and the DMA operations stop transferring data to the transmit buffer. When the buffer is emptied to the threshold level by transmission, the DMA operation activates again to fill the buffer with 8 bytes.

Eventually, the buffer will be emptied at the rate specified by the BAUD Rate settings of the UART_DLL and UART_DLH registers.

If the selected threshold level + trigger level exceeds max buffer size, then the original TX DMA threshold method is used to prevent TX overrun, regardless of the UART_MDR3[1] NONDEFAULT_FREQ value.

The DMA settings should correspond to the system Local Host DMA controller settings in order to ensure the correct operation of this logic.

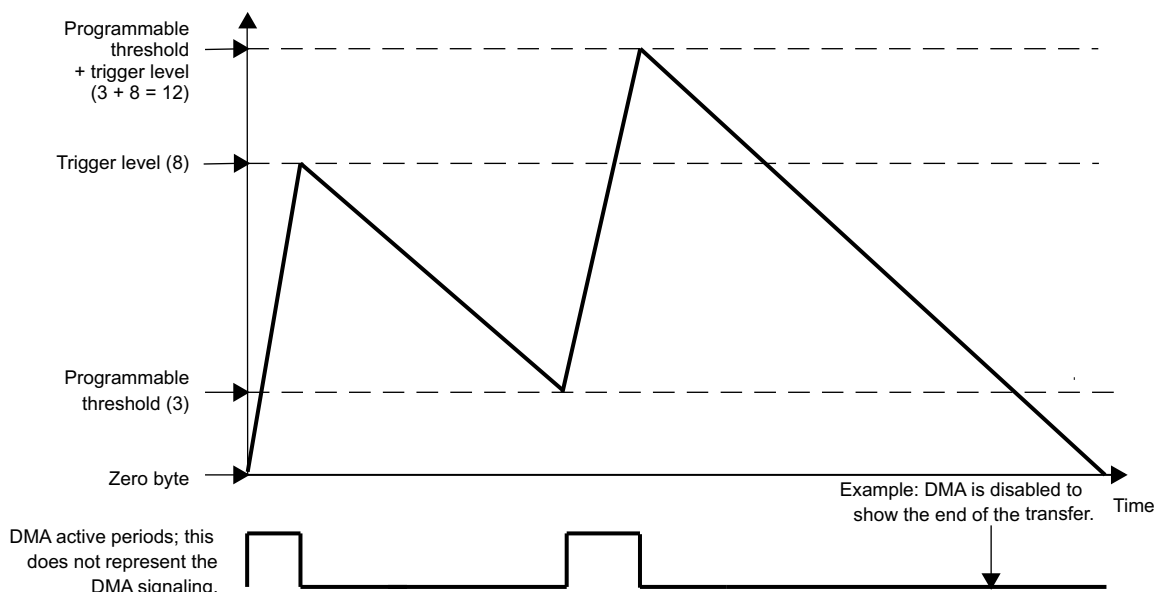

uart-036

Figure 13-85. UART Transmit FIFO DMA Request Generation Using Direct TX DMA Threshold Programming. (Threshold = 3; Spaces = 8)

13.1.4.4.6.4.3 DMA Transmission

Figure 13-86 shows DMA transmission.

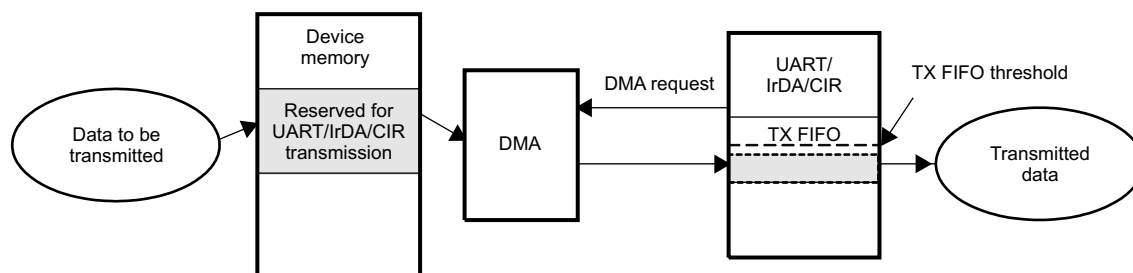

uart-030

Figure 13-86. DMA Transmission

1. Data to be transmitted are put in the device memory reserved for UART transmission by the DMA:
 - a. Until the TX FIFO trigger level is not reached, a DMA request is generated
 - b. An element (1 byte) is transferred from the SDRAM to the TX FIFO at each DMA request (DMA element synchronization).
2. Data in the TX FIFO are automatically transmitted.
3. The end of the transmission is signaled by the UART_THR empty (TX FIFO empty).

Note

In IrDA mode, the transmission does not end immediately after the TX FIFO empties, at which point the last data byte, the CRC field, and the stop flag still must be transmitted; thus, the end of transmission occurs a few milliseconds after the UART_THR register empties.

13.1.4.4.6.4.4 DMA Reception

Figure 13-87 shows DMA reception.

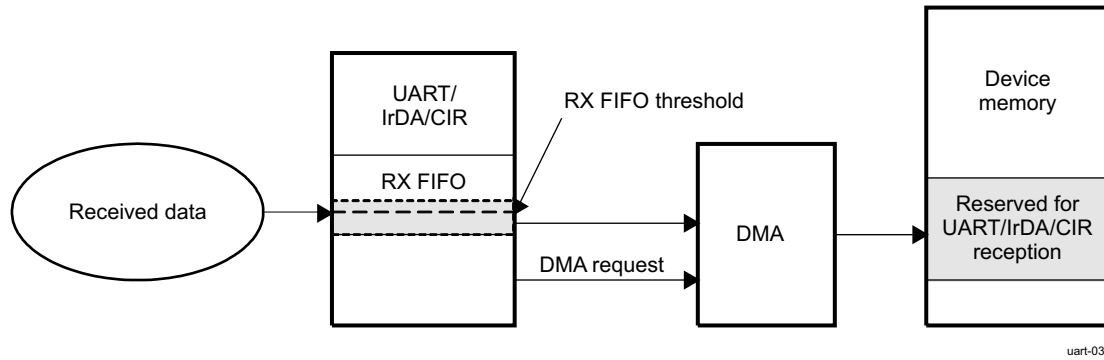

Figure 13-87. DMA Reception

1. Enable the reception.
2. Received data are put in the RX FIFO.
3. Data are transferred from the RX FIFO to the device memory by the DMA:
 - a. At each received byte, the RX FIFO trigger level (one character) is reached and a DMA request is generated.
 - b. An element (1 byte) is transferred from the RX FIFO to the SDRAM at each DMA request (DMA element synchronization).
4. The end of the reception is signaled by the EOF interrupt.

13.1.4.4.7 UART Mode Selection

13.1.4.4.7.1 Register Access Modes

13.1.4.4.7.1.1 Operational Mode and Configuration Modes

Register access depends on the register access mode, although register access modes are not correlated to functional mode selection. Three different modes are available:

- Operational mode
- Configuration mode A
- Configuration mode B

Operational mode is the selected mode when the function is active; serial data transfer can be performed in this mode.

Configuration mode A and configuration mode B are used during module initialization steps. These modes enable access to configuration registers, which are hidden in the operational mode. The modes are used when the module is inactive (no serial data transfer processed) and only for initialization or reconfiguration of the module.

The value of the UART_LCR register determines the register access mode (see Table 13-83).

Table 13-83. UART Register Access Mode Programming (Using UART_LCR)

Mode	Condition
Configuration mode A	UART_LCR[7] = 0x1 and UART_LCR[7-0] != 0xBF
Configuration mode B	UART_LCR[7] = 0x1 and UART_LCR[7-0] = 0xBF
Operational mode	UART_LCR[7] = 0x0

13.1.4.4.7.1.2 Register Access Submode

In each access register mode (operational mode or configuration mode A/B), some register accesses are conditional on the programming of a submode (MSR_SPR, TCR_TLR, and XOFF). These registers are identified in Table 13-106, *UART Load FIFO Triggers Defined by the Concatenated Value*.

Table 13-84 through Table 13-86 summarize the register access submodes.

Table 13-84. UART Subconfiguration Mode A Summary

Mode	Condition
MSR_SPR	(UART_EFR[4] = 0x0 or UART_MCR[6] = 0x0)
TCR_TLR	UART_EFR[4] = 0x1 and UART_MCR[6] = 0x1

Table 13-85. UART Subconfiguration Mode B Summary

Mode	Condition
TCR_TLR	UART_EFR[4] = 0x1 and UART_MCR[6] = 0x1
XOFF	(UART_EFR[4] = 0x0 or UART_MCR[6] = 0x0)

Table 13-86. UART Suboperational Mode Summary

Mode	Condition
MSR_SPR	UART_EFR[4] = 0x0 or UART_MCR[6] = 0x0
TCR_TLR	UART_EFR[4] = 0x1 and UART_MCR[6] = 0x1

13.1.4.4.7.1.3 Registers Available for the Register Access Modes

Table 13-87 lists the names of the register bits in each access register mode. Gray shading indicates that the register does not depend on the register access mode (available in all modes).

Table 13-87. UART Register Access Mode Overview

Address Offset	Registers					
	Configuration Mode A		Configuration Mode B		Operational Mode	
	Read	Write	Read	Write	Read	Write
0x000	UART_DLL	UART_DLL	UART_DLL	UART_DLL	UART_RHR	UART_THR
0x004	UART_DLH	UART_DLH	UART_DLH	UART_DLH	UART_IER_UART	UART_IER_UART
0x008	UART_IIR_UART	UART_FCR	UART_EFR	UART_EFR	UART_IIR_UART	UART_FCR
0x00C	UART_LCR	UART_LCR	UART_LCR	UART_LCR	UART_LCR	UART_LCR
0x010	UART_MCR	UART_MCR	UART_XON1_AD DR1	UART_XON1_AD DR1	UART_MCR	UART_MCR
0x014	UART_LSR_UART	–	UART_XON2_AD DR2	UART_XON2_AD DR2	UART_LSR_UART	–
0x018	UART_MSR / UART_TCR	UART_TCR	UART_TCR / UART_XOFF1	UART_TCR / UART_XOFF1	UART_MSR / UART_TCR	UART_TCR
0x01C	UART_SPR / UART_TLR	UART_SPR / UART_TLR	UART_TLR / UART_XOFF2	UART_TLR / UART_XOFF2	UART_SPR / UART_TLR	UART_SPR / UART_TLR
0x020	UART_MDR1	UART_MDR1	UART_MDR1	UART_MDR1	UART_MDR1	UART_MDR1
0x024	UART_MDR2	UART_MDR2	UART_MDR2	UART_MDR2	UART_MDR2	UART_MDR2
0x028	UART_SFLSR	UART_TXFLL	UART_SFLSR	UART_TXFLL	UART_SFLSR	UART_TXFLL
0x02C	UART_RESUME	UART_TXFLH	UART_RESUME	UART_TXFLH	UART_RESUME	UART_TXFLH
0x030	UART_SFREGH	UART_RXFLL	UART_SFREGH	UART_RXFLL	UART_SFREGH	UART_RXFLL
0x034	UART_SFREGH	UART_RXFLH	UART_SFREGH	UART_RXFLH	UART_SFREGH	UART_RXFLH
0x038	UART_UASR	–	UART_UASR	–	UART_BLR	UART_BLR
0x03C	–	–	–	–	UART_ACREG	UART_ACREG
0x040	UART_SCR	UART_SCR	UART_SCR	UART_SCR	UART_SCR	UART_SCR
0x044	UART_SSR	–	UART_SSR	–	UART_SSR	–
0x048	–	–	–	–	UART_EBLR	UART_EBLR
0x050	UART_MVR	–	UART_MVR	–	UART_MVR	–
0x054	UART_SYSC	UART_SYSC	UART_SYSC	UART_SYSC	UART_SYSC	UART_SYSC
0x058	UART_SYSS	–	UART_SYSS	–	UART_SYSS	–
0x05C	UART_WER	UART_WER	UART_WER	UART_WER	UART_WER	UART_WER

Table 13-87. UART Register Access Mode Overview (continued)

Address Offset	Registers					
	Configuration Mode A		Configuration Mode B		Operational Mode	
	Read	Write	Read	Write	Read	Write
0x060	UART_CFPS	UART_CFPS	UART_CFPS	UART_CFPS	UART_CFPS	UART_CFPS
0x064	UART_RXFIFO_L VL	UART_RXFIFO_L VL	UART_RXFIFO_L VL	UART_RXFIFO_L VL	UART_RXFIFO_L VL	UART_RXFIFO_L VL
0x068	UART_TXFIFO_LV L	UART_TXFIFO_LV L	UART_TXFIFO_LV L	UART_TXFIFO_LV L	UART_TXFIFO_LV L	UART_TXFIFO_LV L
0x06C	UART_IER2	UART_IER2	UART_IER2	UART_IER2	UART_IER2	UART_IER2
0x070	UART_ISR2	UART_ISR2	UART_ISR2	UART_ISR2	UART_ISR2	UART_ISR2
0x074	UART_FREQ_SEL	UART_FREQ_SEL	UART_FREQ_SEL	UART_FREQ_SEL	UART_FREQ_SEL	UART_FREQ_SEL
0x080	UART_MDR3	UART_MDR3	UART_MDR3	UART_MDR3	UART_MDR3	UART_MDR3
0x084	UART_TX_DMA_T HRESHOLD	UART_TX_DMA_T HRESHOLD	UART_TX_DMA_T HRESHOLD	UART_TX_DMA_T HRESHOLD	UART_TX_DMA_T HRESHOLD	UART_TX_DMA_T HRESHOLD

13.1.4.4.7.2 UART/RS-485/IrDA (SIR, MIR, FIR)/CIR Mode Selection

To select a mode, set the UART_MDR1[2:0] MODE_SELECT bit field (see [Table 13-88](#)).

Table 13-88. UART Mode Selection

Value	Mode
0x0:	UART 16× mode
0x1:	SIR mode
0x2:	UART 16× auto-baud
0x3:	UART 13× mode
0x4:	MIR mode
0x5:	FIR mode
0x6:	CIR mode
0x7:	Disable (default state)

MODE_SELECT is effective when the module is in operational mode (see [Section 13.1.4.4.7.1, Register Access Modes](#)).

To select a RS-485 mode, set the UART_MDR3[4] DIR_EN bit field to 0x1.

13.1.4.4.7.2.1 Registers Available for the UART Function

Only the registers listed in [Table 13-89](#) are used for the UART function.

Table 13-89. UART Mode Register Overview

Address Offset	Registers ^{(1) (2)}					
	Configuration Mode A		Configuration Mode B		Operational Mode	
	Read	Write	Read	Write	Read	Write
0x000	UART_DLL	UART_DLL	UART_DLL	UART_DLL	UART_RHR	UART_THR
0x004	UART_DLH	UART_DLH	UART_DLH	UART_DLH	UART_IER_UART (UART)	UART_IER_UART (UART)
0x008	UART_IIR_UART	UART_FCR	UART_EFR [4]	UART_EFR [4]	UART_IIR_UART (UART)	UART_FCR (UART)
0x00C	UART_LCR	UART_LCR	UART_LCR	UART_LCR	UART_LCR	UART_LCR
0x010	UART_MCR	UART_MCR	UART_XON1_AD DR1	UART_XON1_AD DR1	UART_MCR	UART_MCR
0x014	UART_LSR_UART – (UART)	–	UART_XON2_AD DR2	UART_XON2_AD DR2	UART_LSR_UART – (UART)	–

Table 13-89. UART Mode Register Overview (continued)

Address Offset	Registers ^{(1) (2)}					
	Configuration Mode A		Configuration Mode B		Operational Mode	
	Read	Write	Read	Write	Read	Write
0x018	UART_MSR/ UART_TCR	UART_TCR	UART_XOFF1/ UART_TCR	UART_XOFF1/ UART_TCR	UART_MSR/ UART_TCR	UART_TCR
0x01C	UART_TLR/ UART_SPR	UART_TLR/ UART_SPR	UART_TLR/ UART_XOFF2	UART_TLR/ UART_XOFF2	UART_TLR/ UART_SPR	UART_TLR/ UART_SPR
0x020	UART_MDR1	UART_MDR1 [2-0]	UART_MDR1 [2-0]	UART_MDR1 [2-0]	UART_MDR1 [2-0]	UART_MDR1 [2-0]
0x024	UART_MDR2	UART_MDR2	UART_MDR2	UART_MDR2	UART_MDR2	UART_MDR2
0x028	–	–	–	–	–	–
0x02C	–	–	–	–	–	–
0x030	–	–	–	–	–	–
0x034	–	–	–	–	–	–
0x038	UART_UASR	–	UART_UASR	–	–	–
0x03C	–	–	–	–	–	–
0x040	UART_SCR	UART_SCR	UART_SCR	UART_SCR	UART_SCR	UART_SCR
0x044	UART_SSR	–	UART_SSR	–	UART_SSR	–
0x048	–	–	–	–	–	–
0x050	UART_MVR	–	UART_MVR	–	UART_MVR	–
0x054	UART_SYSC	UART_SYSC	UART_SYSC	UART_SYSC	UART_SYSC	UART_SYSC
0x058	UART_SYSS	–	UART_SYSS	–	UART_SYSS	–
0x05C	UART_WER	UART_WER	UART_WER	UART_WER	UART_WER	UART_WER
0x060	–	–	–	–	–	–
0x064	UART_RXFIFO_L VL	UART_RXFIFO_L VL	UART_RXFIFO_L VL	UART_RXFIFO_L VL	UART_RXFIFO_L VL	UART_RXFIFO_L VL
0x068	UART_TXFIFO_LV L	UART_TXFIFO_LV L	UART_TXFIFO_LV L	UART_TXFIFO_LV L	UART_TXFIFO_LV L	UART_TXFIFO_LV L
0x06C	UART_IER2	UART_IER2	UART_IER2	UART_IER2	UART_IER2	UART_IER2
0x070	UART_ISR2	UART_ISR2	UART_ISR2	UART_ISR2	UART_ISR2	UART_ISR2
0x074	UART_FREQ_SEL	UART_FREQ_SEL	UART_FREQ_SEL	UART_FREQ_SEL	UART_FREQ_SEL	UART_FREQ_SEL
0x080	UART_MDR3	UART_MDR3	UART_MDR3	UART_MDR3	UART_MDR3	UART_MDR3
0x084	UART_TX_DMA_T HRESHOLD	UART_TX_DMA_T HRESHOLD	UART_TX_DMA_T HRESHOLD	UART_TX_DMA_T HRESHOLD	UART_TX_DMA_T HRESHOLD	UART_TX_DMA_T HRESHOLD

(1) REGISTER_NAME(UART) notation indicates that the register exists for other functions (IrDA or CIR), but fields have different meanings for other functions (described separately in *UART Registers*).

(2) REGISTER_NAME[m:n] notation indicates that only register bits numbered m to n apply to the UART function.

13.1.4.4.7.2 Registers Available for the IrDA Function

Only the registers listed in [Table 13-90](#) are used for the IrDA function.

Table 13-90. IrDA Mode Register Overview

Address Offset	Registers ^{(1) (2)}					
	Configuration Mode A		Configuration Mode B		Operational Mode	
	Read	Write	Read	Write	Read	Write
0x000	UART_DLL	UART_DLL	UART_DLL	UART_DLL	UART_RHR	UART_THR
0x004	UART_DLH	UART_DLH	UART_DLH	UART_DLH	UART_IER_UART (IrDA)	UART_IER_UART (IrDA)
0x008	UART_IIR_UART	UART_FCR	UART_EFR [4]	UART_EFR [4]	UART_IIR_UART (IrDA)	UART_FCR (IrDA)
0x00C	UART_LCR [7]	UART_LCR [7]	UART_LCR [7]	UART_LCR [7]	UART_LCR [7]	UART_LCR [7]

Table 13-90. IrDA Mode Register Overview (continued)

Address Offset	Registers ^{(1) (2)}					
	Configuration Mode A		Configuration Mode B		Operational Mode	
	Read	Write	Read	Write	Read	Write
0x010	–	–	UART_XON1_AD DR1	UART_XON1_AD DR1	–	–
0x014	UART_LSR_UART (IrDA)	–	UART_XON2_AD DR2	UART_XON2_AD DR2	UART_LSR_UART (IrDA)	–
0x018	UART_MSR/ UART_TCR	UART_TCR	UART_TCR	UART_TCR	UART_MSR/ UART_TCR	UART_TCR
0x01C	UART_TLR/ UART_SPR	UART_TLR/ UART_SPR	UART_TLR	UART_TLR	UART_TLR/ UART_SPR	UART_TLR/ UART_SPR
0x020	UART_MDR1	UART_MDR1	UART_MDR1	UART_MDR1	UART_MDR1	UART_MDR1
0x024	UART_MDR2	UART_MDR2	UART_MDR2	UART_MDR2	UART_MDR2	UART_MDR2
0x028	UART_SFLSR	UART_TXFLL	UART_SFLSR	UART_TXFLL	UART_SFLSR	UART_TXFLL
0x02C	UART_RESUME	UART_TXFLH	UART_RESUME	UART_TXFLH	UART_RESUME	UART_TXFLH
0x030	UART_SFREGL	UART_RXFLL	UART_SFREGL	UART_RXFLL	UART_SFREGL	UART_RXFLL
0x034	UART_SFREGH	UART_RXFLH	UART_SFREGH	UART_RXFLH	UART_SFREGH	UART_RXFLH
0x038	–	–	–	–	UART_BLR	UART_BLR
0x03C	–	–	–	–	UART_ACREG	UART_ACREG
0x040	UART_SCR	UART_SCR	UART_SCR	UART_SCR	UART_SCR	UART_SCR
0x044	UART_SSR	–	UART_SSR	–	UART_SSR	–
0x048	–	–	–	–	UART_EBLR	UART_EBLR
0x050	UART_MVR	–	UART_MVR	–	UART_MVR	–
0x054	UART_SYSC	UART_SYSC	UART_SYSC	UART_SYSC	UART_SYSC	UART_SYSC
0x058	UART_SYSS	–	UART_SYSS	–	UART_SYSS	–
0x05C	UART_WER [6-4]	UART_WER [6-4]	UART_WER [6-4]	UART_WER [6-4]	UART_WER [6-4]	UART_WER [6-4]
0x060	–	–	–	–	–	–
0x064	UART_RXFIFO_L VL	UART_RXFIFO_L VL	UART_RXFIFO_L VL	UART_RXFIFO_L VL	UART_RXFIFO_L VL	UART_RXFIFO_L VL
0x068	UART_TXFIFO_LV L	UART_TXFIFO_LV L	UART_TXFIFO_LV L	UART_TXFIFO_LV L	UART_TXFIFO_LV L	UART_TXFIFO_LV L
0x06C	UART_IER2	UART_IER2	UART_IER2	UART_IER2	UART_IER2	UART_IER2
0x070	UART_ISR2	UART_ISR2	UART_ISR2	UART_ISR2	UART_ISR2	UART_ISR2
0x074	UART_FREQ_SEL	UART_FREQ_SEL	UART_FREQ_SEL	UART_FREQ_SEL	UART_FREQ_SEL	UART_FREQ_SEL
0x080	UART_MDR3	UART_MDR3	UART_MDR3	UART_MDR3	UART_MDR3	UART_MDR3
0x084	UART_TX_DMA_T HRESHOLD	UART_TX_DMA_T HRESHOLD	UART_TX_DMA_T HRESHOLD	UART_TX_DMA_T HRESHOLD	UART_TX_DMA_T HRESHOLD	UART_TX_DMA_T HRESHOLD

(1) REGISTER_NAME(IrDA) notation indicates that the register exists for other functions (UART or CIR), but fields have different meanings for other functions (described separately in *UART Registers*).

(2) REGISTER_NAME[m:n] notation indicates that only register bits numbered m to n apply to the IrDA function.

13.1.4.4.7.2.3 Registers Available for the CIR Function

Only the registers listed in [Table 13-91](#) are used for the CIR function.

Table 13-91. CIR Mode Register Overview

Address Offset	Registers ^{(1) (2)}					
	Configuration Mode A		Configuration Mode B		Operational Mode	
	Read	Write	Read	Write	Read	Write
0x000	UART_DLL	UART_DLL	UART_DLL	UART_DLL	–	UART_THR

Table 13-91. CIR Mode Register Overview (continued)

Address Offset	Registers ⁽¹⁾ ⁽²⁾					
	Configuration Mode A		Configuration Mode B		Operational Mode	
	Read	Write	Read	Write	Read	Write
0x004	UART_DLH	UART_DLH	UART_DLH	UART_DLH	UART_IER_UART (CIR)	UART_IER_UART (CIR)
0x008	UART_IIR_UART	UART_FCR	UART_EFR	UART_EFR	UART_IIR_UART (CIR)	UART_FCR (CIR)
0x00C	UART_LCR	UART_LCR [7]	UART_LCR [7]	UART_LCR [7]	UART_LCR [7]	UART_LCR [7]
0x010	–	–	–	–	–	–
0x014	UART_LSR_UART (CIR)	–	–	–	UART_LSR_UART (CIR)	–
0x018	UART_MSR/ UART_TCR	UART_TCR	UART_TCR	UART_TCR	UART_MSR/ UART_TCR	UART_TCR
0x01C	UART_TLR/ UART_SPR	UART_TLR/ UART_SPR	UART_TLR	UART_TLR	UART_TLR/ UART_SPR	UART_TLR/ UART_SPR
0x020	UART_MDR1 [3-0]	UART_MDR1 [3-0]	UART_MDR1 [3-0]	UART_MDR1 [3-0]	UART_MDR1 [3-0]	UART_MDR1 [3-0]
0x024	UART_MDR2	UART_MDR2	UART_MDR2	UART_MDR2	UART_MDR2	UART_MDR2
0x028	–	–	–	–	–	–
0x02C	UART_RESUME	–	UART_RESUME	–	UART_RESUME	–
0x030	–	–	–	–	–	–
0x034	–	–	–	–	–	–
0x038	–	–	–	–	–	–
0x03C	–	–	–	–	UART_ACREG	UART_ACREG
0x040	UART_SCR	UART_SCR	UART_SCR	UART_SCR	UART_SCR	UART_SCR
0x044	UART_SSR	–	UART_SSR	–	UART_SSR	–
0x048	–	–	–	–	UART_EBLR	UART_EBLR
0x050	UART_MVR	–	UART_MVR	–	UART_MVR	–
0x054	UART_SYSC	UART_SYSC	UART_SYSC	UART_SYSC	UART_SYSC	UART_SYSC
0x058	UART_SYSS	–	UART_SYSS	–	UART_SYSS	–
0x05C	UART_WER [6-4]	UART_WER [6-4]	UART_WER [6-4]	UART_WER [6-4]	UART_WER [6-4]	UART_WER [6-4]
0x060	UART_CFPS	UART_CFPS	UART_CFPS	UART_CFPS	UART_CFPS	UART_CFPS
0x064	UART_RXFIFO_L VL	UART_RXFIFO_L VL	UART_RXFIFO_L VL	UART_RXFIFO_L VL	UART_RXFIFO_L VL	UART_RXFIFO_L VL
0x068	UART_TXFIFO_LV L	UART_TXFIFO_LV L	UART_TXFIFO_LV L	UART_TXFIFO_LV L	UART_TXFIFO_LV L	UART_TXFIFO_LV L
0x06C	UART_IER2	UART_IER2	UART_IER2	UART_IER2	UART_IER2	UART_IER2
0x070	UART_ISR2	UART_ISR2	UART_ISR2	UART_ISR2	UART_ISR2	UART_ISR2
0x074	UART_FREQ_SEL	UART_FREQ_SEL	UART_FREQ_SEL	UART_FREQ_SEL	UART_FREQ_SEL	UART_FREQ_SEL
0x080	UART_MDR3	UART_MDR3	UART_MDR3	UART_MDR3	UART_MDR3	UART_MDR3
0x084	UART_TX_DMA_T HRESHOLD	UART_TX_DMA_T HRESHOLD	UART_TX_DMA_T HRESHOLD	UART_TX_DMA_T HRESHOLD	UART_TX_DMA_T HRESHOLD	UART_TX_DMA_T HRESHOLD

(1) REGISTER_NAME(CIR) notation indicates that the register exists for other functions (IrDA or UART), but fields have different meanings for other functions (described separately in *UART Registers*).

(2) REGISTER_NAME[m:n] notation indicates that only register bits numbered m to n apply to the CIR function.

13.1.4.4.8 UART Protocol Formatting

13.1.4.4.8.1 UART Mode

13.1.4.4.8.1.1 UART Clock Generation: Baud Rate Generation

The UART function contains a programmable baud generator and a set of fixed dividers that divide the 48-MHz clock input down to the expected baud rate.

Figure 13-88 shows the baud rate generator and associated controls.

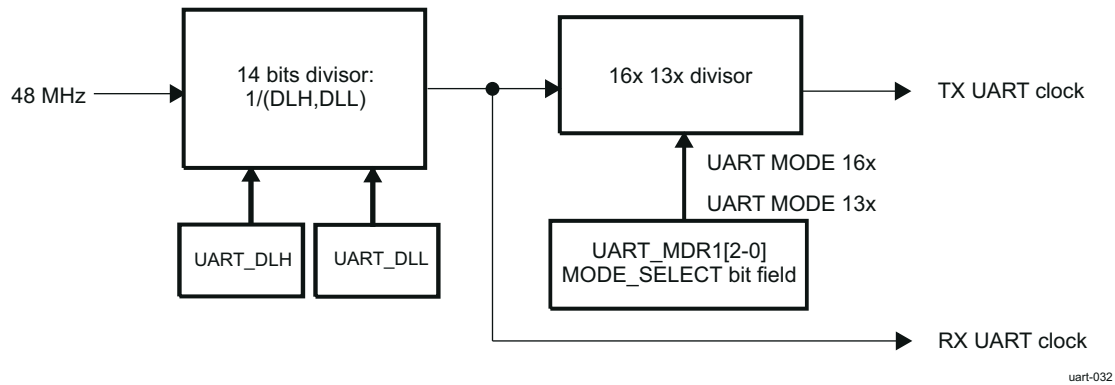

Figure 13-88. UART Baud Rate Generation

CAUTION

Before initializing or modifying clock parameter controls (UART_DLH, UART_DLL), UART_MDR1[2-0] MODE_SELECT = DISABLE must be set to 0x7. Failure to observe this rule can result in unpredictable module behavior.

13.1.4.4.8.1.2 Choosing the Appropriate Divisor Value

Two divisor values are:

- UART 16× mode: Divisor value = Operating frequency / (16× baud rate)
- UART 13× mode: Divisor value = Operating frequency / (13× baud rate)

Table 13-92. UART Baud Rate Settings (48-MHz Clock)

Baud Rate	Baud Multiple	DLH, DLL (Decimal)	DLH, DLL (Hex)	Actual Baud Rate	Error (%)
0.3 kbps	16x	10000	0x27, 0x10	0.3 kbps	0
0.6 kbps	16x	5000	0x13, 0x88	0.6 kbps	0
1.2 kbps	16x	2500	0x09, 0xC4	1.2 kbps	0
2.4 kbps	16x	1250	0x04, 0xE2	2.4 kbps	0
4.8 kbps	16x	625	0x02, 0x71	4.8 kbps	0
9.6 kbps	16x	312	0x01, 0x38	9.6153 kbps	+0.16
14.4 kbps	16x	208	0x00, 0xD0	14.423 kbps	+0.16
19.2 kbps	16x	156	0x00, 0x9C	19.231 kbps	+0.16
28.8 kbps	16x	104	0x00, 0x68	28.846 kbps	+0.16
38.4 kbps	16x	78	0x00, 0x4E	38.462 kbps	+0.16
57.6 kbps	16x	52	0x00, 0x34	57.692 kbps	+0.16
115.2 kbps	16x	26	0x00, 0x1A	115.38 kbps	+0.16
230.4 kbps	16x	13	0x00, 0x0D	230.77 kbps	+0.16
460.8 kbps	13x	8	0x00, 0x08	461.54 kbps	+0.16
921.6 kbps	13x	4	0x00, 0x04	923.08 kbps	+0.16
1.843 Mbps	13x	2	0x00, 0x02	1.846 Mbps	+0.16
3.0 Mbps	16x	1	0x00, 0x01	3.0 Mbps	0
3.6884 Mbps	13x	1	0x00, 0x01	3.6923 Mbps	+0.16

13.1.4.4.8.1.3 Multi-drop Parity Mode with Address Match

Multi-drop mode is enabled in the UART_EFR2 register.

Address matching mode is only available with 8 bit character length setting. UART_LCR[1-0] CHAR_LENGTH bit fields should always be set to 0x11 (8 bits) prior to enabling the feature.

This mode allows the transmitter to send data on a line where multiple receivers are connected, when supported. In this mode, a set parity bit is used to mark an address, and a parity of 0 denotes data.

This setting affects how the parity is generated. Writing a 0x1 into the UART_ECR[0] A_MULTIDROP bit will set the parity bit for the next byte to be sent, which will then be considered an address, for sending a data frame, the UART_ECR[0] A_MULTIDROP bit has to be cleared.

On reception if the feature is enabled by setting the UART_EFR2[2] MULTIDROP bit to 0x1 incoming frames with parity set to 0x1 are treated as address frames and with parity set to 0x0 as data frames. The receiver will drop all data frames until a matching address frame was found.

The matching address is determined by the values set in UART_MAR, UART_MMR and UART_MBR registers and the value set in UART_EFR2[7] BROADCAST bit.

Table 13-93 summarizes the operation of address matching based on the mentioned values.

Table 13-93. Details of address matching

Received frame	Received parity	Frame type	UART_MAR	UART_MMR	UART_MBR	UART_EFR2[7] BROADCAST	Operation of receiver	Address matching
0xXX ⁽²⁾	0	DATA	X ⁽¹⁾	X ⁽¹⁾	0xXX ⁽²⁾	X ⁽¹⁾	Drops data until matching address found	N/A
0xXX ⁽²⁾	1	ADDRESS	0xXX ⁽²⁾	0x00	0xXX ⁽²⁾	0	Matches any address	Yes
0xEF	1	ADDRESS	0xXX ⁽²⁾	0xXX ⁽²⁾	0xEF	1	Matches broadcast address	Yes
0x1A	1	ADDRESS	0x1A	0xFF	0xXX ⁽²⁾	0	Single address match	Yes
0xF5	1	ADDRESS	0xF3	0xF9	0xXX ⁽²⁾	0	Group address match	Yes

(1) X indicates a do not care bit value

(2) 0xXX indicates a do not care 8 bit hexadecimal value

The possible values for matching address can be calculated in the following way:

- Single and Group addresses can be formed by masking the UART_MAR registers value with the value set in the UART_MMR register, bits set to 0x0 in the UART_MMR register result in do not care values.
- Broadcast addresses can be set in the UART_MBR register if broadcast address is enabled in the UART_EFR2[7] BROADCAST bit, the module will match on received address frames containing the broadcast address.
- For more details, see example below:
 - UART_MAR: 0xF3, UART_MMR: 0xF9, UART_MBR: 0xFF
 - Single and Group addresses: 0xF1, 0xF3, 0xF5, 0xF7
 - Broadcast addresses: 0xFF

If an address match occurred the matching address value can be obtained from the UART_RHR register in the following way:

- If the FIFO is disabled or the threshold is set to 0x1, the matching address can be directly read from UART_RHR as the FIFO will not be overwritten.
- If the FIFO is enabled or the threshold is greater than 0x1, the matching address will be the latest frame in the FIFO with a parity error bit set.

For received data, the parity error bit in the UART_LSR_UART register is set when a bit with a parity of 0x1 is received indicating an address frame and the received address matches based on the values of UART_MAR, UART_MMR, UART_MBR and UART_EFR2[2] MULTIDROP bit.

In Multi-drop mode no parity is used, as the parity bit is used to differentiate address and data frames. The parity error bit is used for indicating an address match.

For enabling the interrupt generation for address matching UART_IER_UART[2] LINE_STS_IT bit has to be set to 0x1.

An interrupt for the matching address can be identified by reading the UART_IIR_UART[5-1] IT_TYPE bit fields, a value of 0x00011 indicates a receiver line status error. After the UART_LSR_UART[2] RX_PE bit has to be read, a value of 0x1 indicates that an address match occurred. The reception of a frame is indicated with a value of 0x1 in the UART_LSR_UART[0] RX_FIFO_E bit as the matching value is written into the FIFO regardless of the frame type (data or address). UART_LSR_UART[7] RX_FIFO_STS bit will also be set to 0x1 as the parity error bit is used to indicate a matching address.

Note that the operation of the UART_LSR_UART[2] RX_PE bit depends on the value set in UART_EFR2[2] MULTIDROP bit. If UART_EFR2[2] MULTIDROP bit is set to 0x0, UART_LSR_UART[2] RX_PE bit is used to indicate a received parity error. If UART_EFR2[2] MULTIDROP bit is set to 0x1, the receiver is in Multi-drop Address Match mode, thus the value in UART_LSR_UART[2] RX_PE bit is used to indicate an address match.

The interrupt is cleared the same way in both operation modes: reading the UART_LSR_UART register updates the values.

13.1.4.4.8.1.4 Time-guard

The time-guard feature enables the UART interface to operate with slow remote devices.

When set, it will insert a number of idle states between transmitting two characters, the length of which can be set in the UART_TIMEGUARD register. The value in the register defines the number of baud clocks of idle period to insert.

This idle state essentially acts like a long stop bit.

13.1.4.4.8.1.5 UART Data Formatting

The UART can use hardware flow control to manage transmission and reception. Hardware flow control significantly reduces software overhead and increases system efficiency by automatically controlling serial data flow using the RTS output and CTS input signals.

The UART is enhanced with the autobauding function. In control mode, autobauding lets the speed, the number of bits per character, and the parity selected be set automatically.

13.1.4.4.8.1.5.1 Frame Formatting

When autobauding is not used, frame format attributes must be defined in the UART_LCR register.

Character length is specified using the UART_LCR[1-0] CHAR_LENGTH bit field.

The number of stop-bits is specified using the UART_LCR[2] NB_STOP bit.

The parity bit is programmed using the UART_LCR[5-3] PARITY_EN, UART_LCR[5-3] PARITY_TYPE_1, and UART_LCR[5-3] PARITY_TYPE_2 bit fields (see [Table 13-94](#)).

Table 13-94. UART Parity Bit Encoding

PARITY_EN	PARITY_TYPE_1	PARITY_TYPE_2	Parity
0	N/A	N/A	No parity
1	0	0	Odd parity
1	1	0	Even parity
1	0	1	Forced 1
1	1	1	Forced 0

13.1.4.4.8.1.5.2 Hardware Flow Control

Hardware flow control is composed of auto-CTS and auto-RTS. Auto-CTS and auto-RTS can be enabled and disabled independently by programming the UART_EFR[7] AUTO_CTS_EN and UART_EFR[6] AUTO_RTS_EN bit fields, respectively.

With auto-CTS, CTS signal must be active before the module can transmit data.

Auto-RTS activates the RTS output only when there is enough room in the RX FIFO to receive data. It deactivates the RTS output when the RX FIFO is sufficiently full. The HALT and RESTORE trigger levels in the UART_TCR register determine the levels at which RTS is activated and deactivated.

If auto-CTS and auto-RTS are enabled, data transmission does not occur unless the RX FIFO has empty space. Thus, overrun errors are eliminated during hardware flow control. If auto-CTS and auto-RTS are not enabled, overrun errors occur if the transmit data rate exceeds the RX FIFO latency.

- Auto-RTS:

Auto-RTS data flow control originates in the receiver block. The RX FIFO trigger levels used in auto-RTS are stored in the UART_TCR register. RTS is active if the RX FIFO level is below the HALT trigger level in the UART_TCR[3-0] RX_FIFO_TRIG_HALT bit field. When the RX FIFO HALT trigger level is reached, RTS is deasserted. The sending device (for example, another UART) can send an additional byte after the trigger level is reached because it may not recognize the deassertion of RTS until it begins sending the additional byte.

RTS is automatically reasserted when the RX FIFO reaches the RESUME trigger level programmed by the UART_TCR[7-4] RX_FIFO_TRIG_START bit field. This reassertion requests the sending device to resume transmission.

In this case, RTS is an active-low signal.

- Auto-CTS:

The transmitter circuitry checks CTS before sending the next data byte. When CTS is active, the transmitter sends the next byte. To stop the transmitter from sending the next byte, CTS must be deasserted before the middle of the last stop-bit currently sent.

The auto-CTS function reduces interrupts to the host system. When auto-CTS flow control is enabled, the CTS state changes do not have to trigger host interrupts because the device automatically controls its own transmitter. Without auto-CTS, the transmitter sends any data present in the transmit FIFO, and a receiver overrun error can result.

In this case, CTS is an active-low signal.

13.1.4.4.8.1.5.3 Software Flow Control

Software flow control is enabled through the enhanced feature register (UART_EFR) and the modem control register (UART_MCR). Different combinations of software flow control can be enabled by setting different combinations of the UART_EFR[3-0] bit field (see [Table 13-95](#)).

Two other enhanced features relate to software flow control:

- XON-any function (UART_MCR[5] XON_EN): Operation resumes after receiving any character after the XOFF character is recognized. If special character detect is enabled and special character is received after XOFF1, it does not resume transmission. The special character is stored in the RX FIFO.

Note

The XON-any character is written into the RX FIFO even if it is a software flow character.

- Special character (UART_EFR[5] SPECIAL_CHAR_DETECT): Incoming data is compared to XOFF2. When the special character is detected, the XOFF interrupt (UART_IIR_UART) is set, but it does not halt transmission. The XOFF interrupt is cleared by a read of UART_IIR_UART. The special character is transferred to the RX FIFO. Special character does not work with XON2, XOFF2, or sequential XOFFs.

Table 13-95. UART_EFR[3:0] Software Flow Control Options

Bit 3	Bit 2	Bit 1	Bit 0	TX, RX Software Flow Controls
0	0	X	X	No transmit flow control
1	0	X	X	Transmit XON1, XOFF1
0	1	X	X	Transmit XON2, XOFF2
1	1	X	X	Transmit XON1, XON2: XOFF1, XOFF2 ⁽¹⁾
X	X	0	0	No receive flow control
X	X	1	0	Receiver compares XON1, XOFF1
X	X	0	1	Receiver compares XON2, XOFF2
X	X	1	1	Receiver compares XON1, XON2: XOFF1, XOFF2 ⁽¹⁾

- (1) In these cases, the XON1 and XON2 characters or the XOFF1 and XOFF2 characters must be transmitted/received sequentially with XON1/XOFF1 followed by XON2/XOFF2.
XON1 is defined in the UART_XON1_ADDR1[7-0] XON_WORD1 bit field. XON2 is defined in the UART_XON2_ADDR2[7-0] XON_WORD2 bit field.
XOFF1 is defined in the UART_XOFF1[7-0] XOFF_WORD1 bit field. XOFF2 is defined in the UART_XOFF2[7-0] XOFF_WORD2 bit field.

1.4.4.8.1.5.3.1 Receive (RX)

When software flow control operation is enabled, the UART compares incoming data with XOFF1/2 programmed characters (in certain cases, XOFF1 and XOFF2 must be received sequentially). When the correct XOFF characters are received, transmission stops after transmission of the current character completes. Detection of XOFF also sets the UART_IIR_UART[4] bit (if enabled by UART_IER_UART[5]) and causes the interrupt line to go low.

To resume transmission, an XON1/2 character must be received (in certain cases, XON1 and XON2 must be received sequentially). When the correct XON characters are received, the UART_IIR_UART[4] bit is cleared and the XOFF interrupt disappears.

Note

When a parity, framing, or break error occurs while receiving a software flow control character, this character is treated as normal data and is written to the RX FIFO.

When XON-any and special character detect are disabled and software flow control is enabled, no valid XON or XOFF characters are written to the RX FIFO. For example, when UART_EFR[1-0] = 0x2, if XON1 and XOFF1 characters are received, they are not written to the RX FIFO.

When pairs of software flow characters are programmed to be received sequentially (UART_EFR[1-0] = 0x3), the software flow characters are not written to the RX FIFO if they are received sequentially. However, received XON1/XOFF1 characters must be written to the RX FIFO if the subsequent character is not XON2/XOFF2.

1.4.4.8.1.5.3.2 Transmit (TX)

Two XOFF1 characters are transmitted when the RX FIFO passes the trigger level programmed by UART_TCR[3-0] RX_FIFO_TRIG_HALT. As soon as the RX FIFO reaches the trigger level programmed by UART_TCR[7-4] RX_FIFO_TRIG_START, two XON1 characters are sent, so the data transfer recovers.

Note

If software flow control is disabled after an XOFF character is sent, the module transmits XON characters automatically to enable normal transmission.

The transmission of XOFF(s)/XON(s) follows the same protocol as transmission of an ordinary byte from the TX FIFO. This means that even if the word length is 5, 6, or 7 characters, the 5, 6, or 7 LSBs of XOFF1/2 and XON1/2 are transmitted. The 5, 6, or 7 bits of a character are seldom transmitted, but this function is included to maintain compatibility with earlier designs.

It is assumed that software flow control and hardware flow control are never enabled simultaneously.

13.1.4.4.8.1.5.4 Autobauding Modes

In autobauding mode, the UART can extract transfer characteristics (speed, length, and parity) from an "at" (AT) command (ASCII code). These characteristics are used to receive data after an AT and to send data.

The following AT commands are valid:

AT	DATA	<CR>
at	DATA	<CR>
A/		
a/		

A line break during the acquisition of the sequence AT is not recognized, and an echo function is not implemented in hardware.

A/ and a/ are not used to extract characteristics, but they must be recognized because of their special meaning. A/ or a/ is used to instruct the software to repeat the last received AT command; therefore, an a/ always follows an AT, and transfer characteristics are not expected to change between an AT and an a/.

When a valid AT is received, AT and all subsequent data, including the final <CR> (0x0D), are saved to the RX FIFO. The autobaud state-machine waits for the next valid AT command. If an a/ (A/) is received, the a/ (A/) is saved in the RX FIFO and the state-machine waits for the next valid AT command.

On the first successful detection of the baud rate, the UART activates an interrupt to signify that the AT (upper or lower case) sequence is detected. The UART_UASR register reflects the correct settings for the baud rate detected. Interrupt activity can continue in this fashion when a subsequent character is received. Therefore, it is recommended that the software enable the RHR interrupt when using the autobaud mode.

The following settings are detected in autobaud mode with a module clock of 48 MHz:

- Speed:
 - 115.2K baud
 - 57.6K baud
 - 38.4K baud
 - 28.8K baud
 - 19.2K baud
 - 14.4K baud
 - 9.6K baud
 - 4.8K baud
 - 2.4K baud
 - 1.2K baud
- Length: 7 or 8 bits
- Parity: Odd, even, or space

Note

The combination of 7-bit character plus space parity is not supported.

Autobauding mode is selected when the UART_MDR1[2-0] MODE_SELECT bit field is set to 0x2. In UART autobauding mode, UART_DLL, UART_DLH, and UART_LCR[5-0] bit field settings are not used; instead, the UART_UASR register is updated with the configuration detected by the autobauding logic.

UASR Autobauding Status Register Use

This register is used to set up transmission according to the characteristics of the previous reception instead of the UART_LCR, UART_DLL, and UART_DLH registers when the UART is in autobauding mode.

To reset the autobauding hardware (to start a new AT detection) or to set the UART in standard mode (no autobaud), the UART_MDR1[2-0] MODE_SELECT bit field must be set to reset state (0x7) and then to the UART in autobauding mode (0x2) or to the UART in standard mode (0x0).

Use limitation:

- Only 7- and 8-bit characters (5- and 6-bit not supported)
- 7-bit character with space parity not supported
- Baud rate between 1200 and 115.2 bps (10 possibilities)

13.1.4.4.8.1.5.5 Error Detection

When the UART_LSR_UART register is read, the UART_LSR_UART[4:2] bit field reflects the error bits (BI: break condition, FE: framing error, PE: parity error) of the character at the top of the RX FIFO (the next character to be read). Therefore, reading the UART_LSR_UART register and then reading the UART_RHR register identifies errors in a character.

Reading the UART_RHR register updates the BI, FE, and PE bits (see [Table 13-78](#) for the UART mode interrupts).

The UART_LSR_UART[7] RX_FIFO_STS bit is set when there is an error in the RX FIFO and is cleared only when no errors remain in the RX FIFO.

Note

Reading the UART_LSR_UART register does not cause an increment of the RX FIFO read pointer. The RX FIFO read pointer is incremented by reading the UART_RHR register.

Reading the UART_LSR_UART register clears the OE bit if it is set (see [Table 13-78](#) for the UART mode interrupts).

13.1.4.4.8.1.5.6 Overrun During Receive

Overrun during receive occurs if the RX state-machine tries to write data into the RX FIFO when it is already full. When overrun occurs, the device interrupts the Host CPU with the UART_IIR_UART[5-1] IT_TYPE bit field set to 0x3 (receiver line status error) and discards the remaining portion of the frame.

Overrun also causes an internal flag to be set, which disables further reception. Before the next frame can be received, the Host CPU must:

- Reset the RX FIFO.
- Read the UART_RESUME register, which clears the internal flag.

13.1.4.4.8.1.5.7 Time-Out and Break Conditions

1.4.4.8.1.5.7.1 Time-Out Counter

An RX idle condition is detected when the receiver line (RX) is high for a time that equals 4x the programmed word length + 12 bits or manually configured amount of baud clocks, if a value other zero is set in the timeout register. RX is sampled midway through each bit.

For sleep mode, the counter is reset when there is activity on RX.

There are two modes of operation:

- In default operation on the UART_EFR2[6] TIMEOUT_BEHAVE is set to 0. For the time-out interrupt, the counter counts only when there is data in the RX FIFO, and the count is reset when there is activity on RX or when the UART_RHR register is read.
- Optionally, for choose to enable the timeout counter even if no character has been received by setting UART_EFR2[6] TIMEOUT_BEHAVE bit. This will generate periodic interrupts if the RX line remains idle. In this mode the counter will auto-reset when a timeout has been reached. Reading the UART_IIR_UART will clear the interrupt, but not the counter.

1.4.4.8.1.5.7.2 Break Condition

When a break condition occurs, TX is pulled low. A break condition is activated by setting the UART_LCR[6] BREAK_EN bit. The break condition is not aligned on word stream (a break condition can occur in the middle of a character). The only way to send a break condition on a full character is:

1. Reset the TX FIFO (if enabled).
2. Wait for the transmit shift register to empty (the UART_LSR_UART[6] TX_SR_E bit is set to 1).
3. Take a guard time according to stop-bit definition.
4. Set the BREAK_EN bit to 1.

The break condition is asserted while the BREAK_EN bit is set to 1.

The time-out counter and break condition apply only to UART modem operation and not to IrDA/CIR mode operation.

13.1.4.4.8.2 RS-485 Mode

13.1.4.4.8.2.1 RS-485 External Transceiver Direction Control

The UART_MDR3[4] DIR_EN bit enables hardware control over an external transceiver to support RS-485. The direction signal comes across the DIR port. The direction polarity is controlled by the UART_MDR3[3] DIR_POL bit. The direction is determined by the hardware monitoring the TX FIFO and the TX shift register. When both are empty the transceiver is set to RX. There is a guard band delay counter of 3 bit clock cycles after the TX shift register is going empty to allow time for the stop bit to transition through the transceiver before a direction change to receive might be applied.

Figure 13-89 shows the direction control.

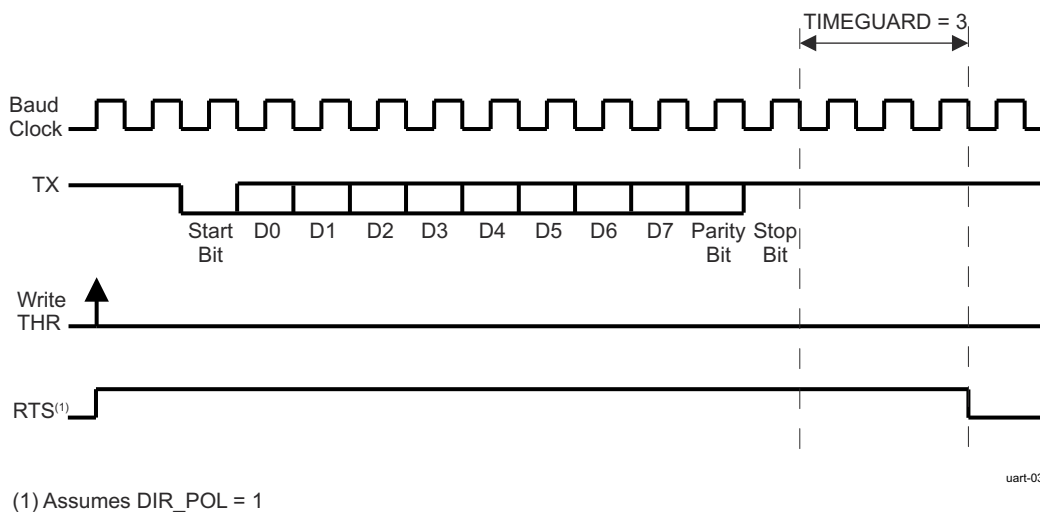

Figure 13-89. RS-485 External Transceiver Direction Control

13.1.4.4.8.3 IrDA Mode

13.1.4.4.8.3.1 IrDA Clock Generation: Baud Generator

The IrDA function contains a programmable baud generator and a set of fixed dividers that divide the 48-MHz clock input down to the expected baud rate.

Figure 13-90 shows the baud rate generator and associated controls.

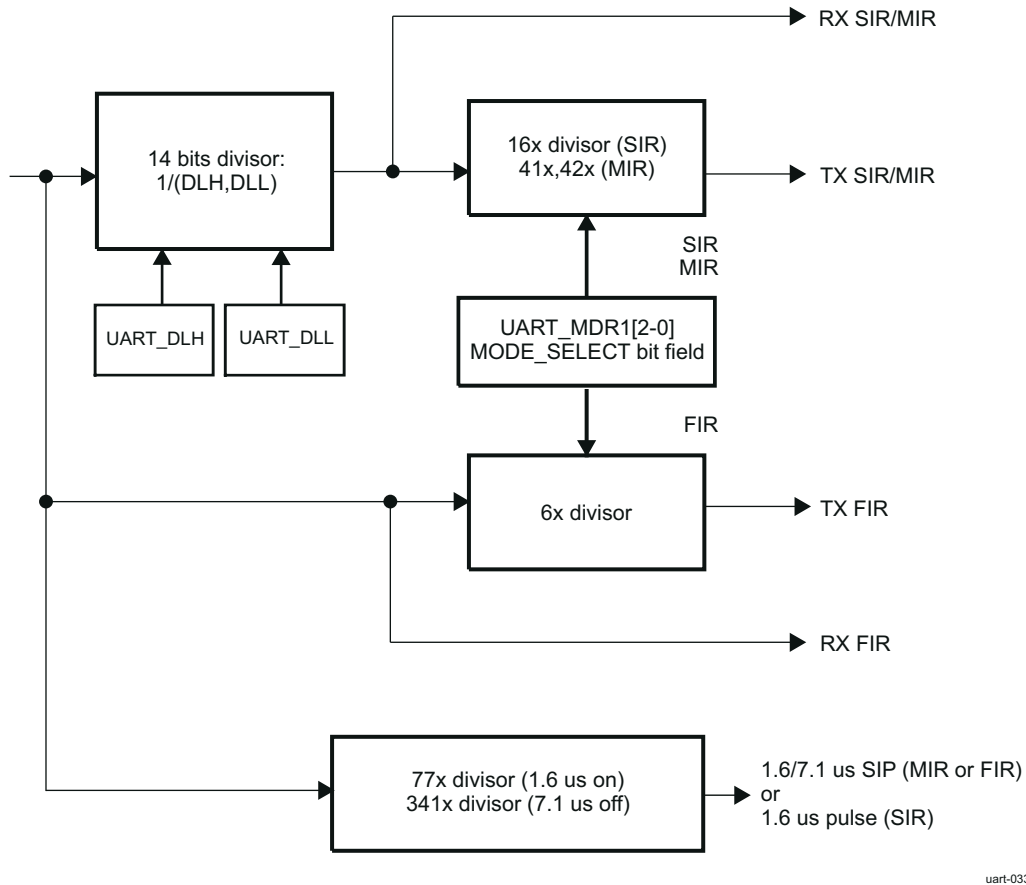

Figure 13-90. IrDA Baud Rate Generator

CAUTION

Before initializing or modifying clock parameter controls (UART_DLH, UART_DLL), MODE_SELECT=DISABLE (UART_MDR1[2-0] MODE_SELECT) must be set to 0x7). Failure to observe this rule can result in unpredictable module behavior.

13.1.4.4.8.3.2 Choosing the Appropriate Divisor Value

Three divisor values are:

- SIR mode: Divisor value = Operating frequency/(16× baud rate)
- MIR mode: Divisor value = Operating frequency/(41×/42× baud rate)
- FIR mode: Divisor value = None

Table 13-96 lists the IrDA baud rate settings.

Table 13-96. IrDA Baud Rate Settings

Baud Rate	IR Mode	Baud Multiple	Encoding	DLH, DLL (Decimal)	Actual Baud Rate	Error (%)	Source Jitter (%)	Pulse Duration
2.4 kbps	SIR	16x	3/16	1250	2.4 kbps	0	0	78.1 μs
9.6 kbps	SIR	16x	3/16	312	9.6153 kbps	+0.16	0	19.5 μs
19.2 kbps	SIR	16x	3/16	156	19.231 kbps	+0.16	0	9.75 μs
38.4 kbps	SIR	16x	3/16	78	38.462 kbps	+0.16	0	4.87 μs
57.6 kbps	SIR	16x	3/16	52	57.692 kbps	+0.16	0	3.25 μs
115.2 kbps	SIR	16x	3/16	26	115.38 kbps	+0.16	0	1.62 μs

Table 13-96. IrDA Baud Rate Settings (continued)

Baud Rate	IR Mode	Baud Multiple	Encoding	DLH, DLL (Decimal)	Actual Baud Rate	Error (%)	Source Jitter (%)	Pulse Duration
0.576 Mbps	MIR	41×/42×	1/4	2	0.5756 Mbps ⁽¹⁾	0	+1.63/-0.80	416 ns
1.152 Mbps	MIR	41×/42×	1/4	1	1.1511 Mbps ⁽¹⁾	0	+1.63/-0.80	208 ns
4 Mbps	FIR	6×	4 PPM	–	4 Mbps	0	0	125 ns

(1) Average value

Note

Baud rate error and source jitter table values do not include 48-MHz reference clock error and jitter.

13.1.4.4.8.3.3 IrDA Data Formatting

The methods described in this section apply to all IrDA modes (SIR, MIR, and FIR).

13.1.4.4.8.3.3.1 IR RX Polarity Control

The UART_MDR2[6] IRRXINVERT bit provides the flexibility to invert the RX pin in the UART to ensure that the protocol at the output of the transceiver has the same polarity at module level. By default, the RX pin is inverted because most transceivers invert the IR receive pin.

13.1.4.4.8.3.3.2 IrDA Reception Control

The module can transmit and receive data, but when the device is transmitting, the IR RX circuitry is automatically disabled by hardware.

Operation of the RX input can be disabled by the UART_ACREG[5] DIS_IR_RX bit.

13.1.4.4.8.3.3.3 IR Address Checking

In all IR modes, when address checking is enabled, only frames intended for the device are written to the RX FIFO. This restriction avoids receiving frames not meant for this device in a multipoint infrared environment. It is possible to program two frame addresses that the UART IrDA receives, with the UART_XON1_ADDR1[7-0] XON_WORD1 and UART_XON2_ADDR2[7-0] XON_WORD2 bit fields.

Setting the UART_EFR[0] bit to 1 selects address1 checking. Setting the UART_EFR[1] bit to 1 selects address2 checking. Setting the UART_EFR[1-0] bit field to 0 disables all address checking operations. If both bits are set, the incoming frame is checked for private and public addresses.

If address checking is disabled, all received frames write to the RX FIFO.

13.1.4.4.8.3.3.4 Frame Closing

A transmission frame can be terminated in two ways:

- Frame-length method: Set the UART_MDR1[7] FRAME_END_MODE bit to 0. The Host CPU writes the value of the frame length to the UART_TXFLH and UART_TXFLL registers. The device automatically attaches end flags to the frame when the number of bytes transmitted equals the value of the frame length.
- Set-EOT bit method: Set the UART_MDR1[7] FRAME_END_MODE bit to 1. The Host CPU writes 1 to the UART_ACREG[0] EOT bit just before it writes the last byte to the TX FIFO. When the Host CPU writes the last byte to the TX FIFO, the device internally sets the tag bit for that character in the TX FIFO. As the TX state-machine reads data from the TX FIFO, it uses this tag-bit information to attach end flags and correctly terminate the frame.

13.1.4.4.8.3.3.5 Store and Controlled Transmission

In store and controlled transmission (SCT) mode, the Host CPU starts writing data to the TX FIFO. Then, after writing a part of a frame (for a bigger frame) or an entire frame (a small frame; that is, a supervisory frame), the Host CPU writes 1 to the UART_ACREG[2] SCTX_EN bit (deferred TX start) to start transmission.

SCT mode is enabled by setting the UART_MDR1[5] SCT bit to 1. This transmission method differs from normal mode, in which data transmission starts immediately after data is written to the TX FIFO. SCT mode is useful for sending short frames without TX underrun.

13.1.4.4.8.3.3.6 Error Detection

When the UART_LSR_UART register is read, the UART_LSR_UART[4-2] bit field reflects the error bits [FL, CRC, ABORT] of the frame at the top of the STATUS FIFO (the next frame status to be read).

The error is triggered by an interrupt (for IrDA mode interrupts, see [Table 13-79](#)). The STATUS FIFO must be read until empty (a maximum of eight reads is required).

13.1.4.4.8.3.3.7 Underrun During Transmission

Underrun during transmission occurs when the TX FIFO is empty before the end of the frame is transmitted. When underrun occurs, the device closes the frame with end flags but attaches an incorrect CRC value. The receiving device detects a CRC error and discards the frame; it can then ask for a retransmission.

Underrun also causes an internal flag to be set, which disables additional transmissions. Before the next frame can be transmitted, the Host CPU must:

- Reset the TX FIFO.
- Read the UART_RESUME register, which clears the internal flag.

This function can be disabled by the UART_ACREG[4] DIS_TX_UNDERRUN bit, compensated by the extension of the stop-bit in transmission if the TX FIFO is empty.

13.1.4.4.8.3.3.8 Overrun During Receive

Overrun during receive for the IrDA mode has the same function as that for the UART mode (see [Section 13.1.4.4.8.1.5.6, Overrun During Receive](#)).

13.1.4.4.8.3.3.9 Status FIFO

In IrDA modes, a status FIFO records the received frame status. When a complete frame is received, the length of the frame and the error bits associated with the frame are written to the status FIFO.

Reading the UART_SFREGH[3-0] MSB and UART_SFREGL[3-0] (LSB) bit fields obtains the frame length. The frame error status is read in the UART_SFLSR register. Reading the UART_SFLSR register increments the status FIFO read pointer. Because the status FIFO is eight entries deep, it can hold the status of eight frames.

The Host CPU uses the frame-length information to locate the frame boundary in the received frame data. The Host CPU can screen bad frames using the error status information and can later request the sender to resend only the bad frames.

This status FIFO can be used effectively in DMA mode because the Host CPU must be interrupted only when the programmed status FIFO trigger level is reached, not each time a frame is received.

13.1.4.4.8.3.4 SIR Mode Data Formatting

This section provides specific instructions for SIR mode programming.

13.1.4.4.8.3.4.1 Abort Sequence

The transmitter can prematurely close a frame (abort) by sending the sequence 0x7DC1. The abort pattern closes the frame without a CRC field or an ending flag.

A transmission frame can be aborted by setting the UART_ACREG[1] ABORT_EN bit to 1. When this bit is set to 1, 0x7D and 0xC1 are transmitted and the frame is not terminated with CRC or stop flags.

When a 0x7D character followed immediately by a 0xC1 character is received without transparency, the receiver treats a frame as an aborted frame.

CAUTION

When the TX FIFO is not empty and the UART_MDR1[5] SCT bit is set to 1, the UART IrDA starts a new transfer with data of a previous frame when the aborted frame is sent. Therefore, the TX FIFO must be reset before sending an aborted frame.

13.1.4.4.8.3.4.2 Pulse Shaping

SIR mode supports the 3/16 or the 1.6- μ s pulse duration methods. The UART_ACREG[7] PULSE_TYPE bit selects the pulse width method in the transmit mode.

13.1.4.4.8.3.4.3 SIR Free Format Programming

The SIR FF mode is selected by setting the module in the UART mode (UART_MDR1[2-0] MODE_SELECT = 0x0) and the UART_MDR2[3] PULSE bit to 1 to allow pulse shaping.

Because the bit format stays the same, some UART mode configuration registers must be set at specific values:

- UART_LCR[1-0] CHAR_LENGTH bit field = 0x3 (8 data bits)
- UART_LCR[2] NB_STOP bit = 0x0 (1 stop-bit)
- UART_LCR[3] PARITY_EN bit = 0x0 (no parity)

The UART mode interrupts are used for the SIR FF mode, but many are not relevant (XOFF, RTS, CTS, modem status register, etc.).

13.1.4.4.8.3.5 MIR and FIR Mode Data Formatting

This section describes common instructions for FIR and MIR mode programming.

At the end of a frame reception, the CPU reads the line status register (UART_LSR_UART) to detect errors in the received frame.

When the UART_MDR1[6] SIP_MODE bit is set to 1, the TX state-machine always sends one SIP at the end of a transmission frame. However, when the SIP_MODE bit is set to 0, SIP transmission depends on the UART_ACREG[3] SEND_SIP bit.

The CPU can set the SEND_SIP bit at least once every 500 ms. The advantage of this approach over the default approach is that the TX state-machine does not have to send the SIP at the end of each frame, thus reducing the overhead required.

13.1.4.4.8.4 CIR Mode

13.1.4.4.8.4.1 CIR Mode Clock Generation

Depending on the encoding method (variable pulse distance/biphase), the Host CPU must develop a data structure that combines 1 and 0 with a t period to encode the complete frame to transmit. This can then be transmitted to the infrared output with a modulation method, as shown in [Figure 13-91](#).

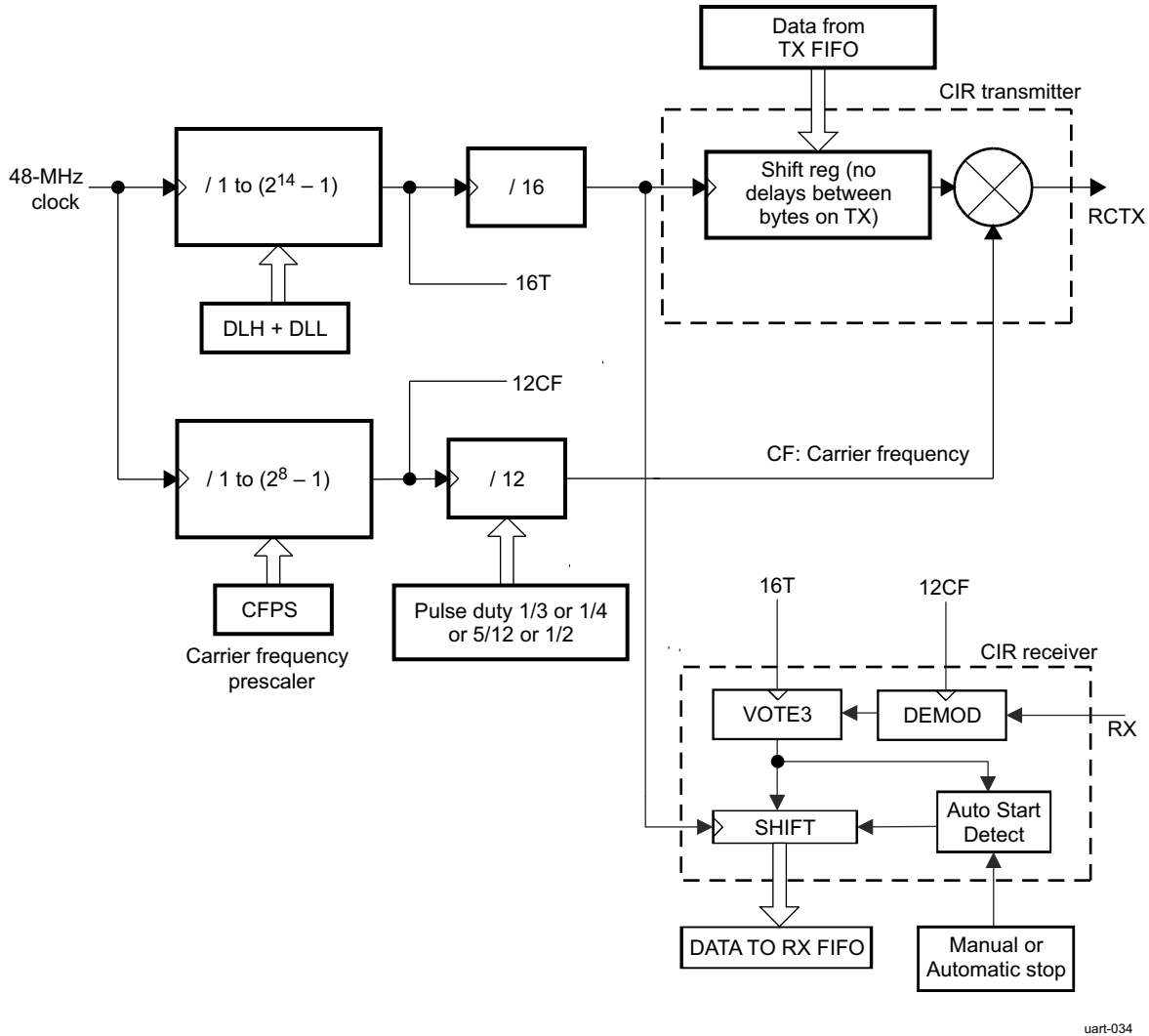

Figure 13-91. CIR Mode Block Components

Based on the requested modulation frequency, the UART_CFPS register must be set with the correct dividing value to provide an accurate pulse frequency:

$$\text{Dividing value} = (\text{FCLK} / 12) / \text{MODfreq}$$

Where:

FCLK = System clock frequency (48 MHz)

12 = Real value of baud multiple

MODfreq = Effective frequency of the modulation (MHz)

Example: For a targeted modulation frequency of 36 kHz, the value of CFPS must be set to 0x7 (decimal), which provides a modulation frequency of 36.04 kHz.

Note

The UART_CFPS register starts with a reset value of 105 (decimal), which translates to a frequency of 38.1 kHz.

The duty cycle of these pulses is user-defined by the pulse duty register bits in the UART_MDR2 register. [Table 13-97](#) shows the duty cycle.

uart-034

Table 13-97. CIR Duty Cycle

UART_MDR2[5-4] CIR_PULSE_MODE	Duty Cycle (High-Level)
00	1/4
01	1/3
10	5/12
11	1/2

13.1.4.4.8.4.2 CIR Data Formatting

The methods described in this section apply to all CIR modes.

13.1.4.4.8.4.2.1 IR RX Polarity Control

The IR RX polarity control for CIR mode has the same function as that for IrDA mode (see [Section 13.1.4.4.8.3.3.1, IR RX Polarity Control](#)).

13.1.4.4.8.4.2.2 CIR Transmission

In transmission, the Host CPU software must exercise an element of real-time control to transmit data packets, each of which must be emitted at a constant delay from the start-bits of each individual packet. Thus, when sending a series of packets, the packet-to-packet delay must respect a specific delay. Two methods can be used to control this delay:

- Filling the TX FIFO with a number of zero bits that are transmitted with a t period
- Using an external system timer to control the delay between each start-of-frame or between the end of a frame and the start of the next one. This can be performed by:
 - Controlling the start of the frame using the UART_MDR1[5] SCT bit and the UART_ACREG[2] SCTX_EN bit, depending on the timer status
 - Using the UART_IIR_UART[5] TX_STATUS_IT interrupt bit to preload the next frame in the TX FIFO and to control the start of the timer (in case of control delay between the end of a frame and the start of the next frame)

13.1.4.4.8.4.2.3 CIR Reception

In reception, there are 2 ways to stop it

- The Host CPU can disable the reception by setting the UART_ACREG[5] DIS_IR_RX bit to 1. When it considers that the reception is finished because a large number of 0 has been received. To receive a new frame, the UART_ACREG[5] DIS_IR_RX bit must be set to 0.
- Using a specific mechanism, depending on the value set in the BOF length register (UART_EBLR), allows stopping automatically the reception. If the value set in the UART_EBLR register is different than 0, this features is enabled and count a number of bit received at 0. When the counter achieved the value defined in the UART_EBLR register, the reception is automatically stop and UART_IIR_CIR[2] RX_STOP_IT bit is set. When a 1 is detected on the RX pin, the reception is automatically enabled.

There is a limitation when receiving data in UART CIR mode. The IrDA transceivers on the market have a common characteristic that shrinks the hold time of the received modulation pulse. The UART filtering schema on receiving is based on the same encoding mechanism used in transmission.

For the following scenario:

- shift register period: 0.9us
- modulation frequency: 36kHz
- duty cycle: 1/4 of a modulation frequency period

So the data sent in those conditions would look like 7us pulses within 28us period. The UART expects to receive similar incoming data on receive, but available transceiver timing characteristics typically send 2us modulated pulses. Those will be filtered out and RX FIFO will not receive any data.

This does not affect UART CIR mode in transmission.

Note

The CIR RX demodulation can be bypassed by setting the UART_MDR3[0] DISABLE_CIR_RX_DEMOD bit.

13.1.4.5 UART Programming Guide

This section describes the procedure for operating the UART with FIFO and DMA or interrupts. This three-part procedure ensures the quick start of the UART. It does not cover every UART feature.

The first programming model covers software reset of the UART. The second programming model describes FIFO and DMA configuration. The last programming model describes protocol, baud rate, and interrupt configuration.

Note

Each programming model can be used independently of the other two; for instance, reconfiguring the FIFOs and DMA settings only.

Each programming model can be executed starting from any UART register access mode (register modes, submodes, and other register dependencies). However, if the UART register access mode is known before executing the programming model, some steps that enable or restore register access are optional. For more information, see [Section 13.1.4.4.7.1, Register Access Modes](#).

13.1.4.5.1 UART Global Initialization

13.1.4.5.1.1 Surrounding Modules Global Initialization

This section identifies the requirements for initializing the surrounding modules when the UART module is to be used for the first time after a device reset. This initialization of surrounding modules is based on the integration of the UART.

For more information, see [, UART Integration](#).

13.1.4.5.1.2 UART Module Global Initialization

The procedure in [Table 13-98](#) can be used to initialize UART when performing software reset.

Table 13-98. UART Global Initialization

Step	Register/Bit Field/Programming Model	Value
Perform a software reset.	UART_SYSC[1] SOFTRESET	1
Wait until reset is finished.	UART_SYSS[0] RESETDONE	=1

13.1.4.5.2 UART Mode selection

[Table 13-99](#) describes how to set different register access mode.

Table 13-99. UART Configure Register Access Mode

Step	Register/Bit Field/Programming Model	Value
Set the register access mode A	UART_LCR[7] DIV_EN	1
	UART_LCR[7-0]	≠0xBF
Set the register access mode B	UART_LCR[7-0]	0xBF
Set the operational mode	UART_LCR[7] DIV_EN	0

13.1.4.5.3 UART Submode selection

This section describes how to set different register access submode.

Table 13-100. UART Configure Register Access Submode TCR_TLR

Step	Register/Bit Field/Programming Model	Value
Configure the submode TCR_TLR		
Configure mode B	see Table 13-99	
Enable writing to register bits UART_MCR[7-5]	UART_EFR[4] ENHANCED_EN	1
Configure mode A	see Table 13-99	0x1

Table 13-100. UART Configure Register Access Submode TCR_TLR (continued)

Step	Register/Bit Field/Programming Model	Value
Set the submode TCR_TLR	UART_MCR[6] TCR_TLR	1

Table 13-101. UART Configure Register Access Submode MSR_SPR

Step	Register/Bit Field/Programming Model	Value
First option: configure the submode MSR_SPR		
Configure mode B	see Table 13-99	
Set the submode MSR_SPR	UART_EFR[4] ENHANCED_EN	0
Second option: configure the submode MSR_SPR		
Configure mode B	see Table 13-99	
Enable writing to register bits UART_MCR[7-5]	UART_EFR[4] ENHANCED_EN	1
Set the submode MSR_SPR	UART_MCR[6] TCR_TLR	0

Table 13-102. UART Configure Register Access Submode XOFF

Step	Register/Bit Field/Programming Model	Value
Configure of the XOFF		
Configure B	see Table 13-99	
Set the submode XOFF	UART_EFR[4] ENHANCED_EN	0

13.1.4.5.4 UART Load FIFO trigger and DMA mode settings

13.1.4.5.4.1 DMA mode Settings

To enable and configure program the DMA mode, perform the following steps:

Table 13-103. DMA Mode Settings

Step	Register/Bit Field/Programming Model	Value
Set the option of DMA mode configuration	UART_SCR[0] DMA_MODE_CTL	-
IF Configure DMA mode 0 and 1	UART_SCR[0] DMA_MODE_CTL	=0
Select the DMA mode, for more information see Section 13.1.4.4.6.4	UART_FCR[3] DMA_MODE	-
IF Configure DMA mode from 0 to 3	UART_SCR[0] DMA_MODE_CTL	=1
Select the DMA mode, for more information see Section 13.1.4.4.6.4	UART_SCR[2-1] DMA_MODE_2	-

13.1.4.5.4.2 FIFO Trigger Settings

In this section is described configuration and settings of FIFO trigger level, which enable DMA and interrupt generation.

Table 13-104. Load FIFO Triggers Defined by the FCR

Step	Register/Bit Field/Programming Model	Value
Configure register submode TCR_TLR	see Table 13-100	0x-
Set the desire RX FIFO trigger level	UART_FCR[5-4] TX_FIFO_TRIG	0x-
Set the desire TX FIFO trigger level	UART_FCR[7-6] RX_FIFO_TRIG	0x-

Table 13-105. Load FIFO Triggers Defined by the TLR

Step	Register/Bit Field/Programming Model	Value
Configure register submode TCR_TLR	see Table 13-100	0x-
Set the desire RX FIFO trigger level	UART_TLR[7-4] RX_FIFO_TRIG_DMA	0x-
Set the desire TX FIFO trigger level	UART_TLR[3-0] TX_FIFO_TRIG_DMA	0x-

Table 13-106. Load FIFO Triggers Defined by the Concatenated Value

Step	Register/Bit Field/Programming Model	Value
Configure register submode TCR_TLR	see Table 13-100	0x-
Set the register bit	UART_SCR[7] RX_TRIG_GRANU1	1
Set the desire RX FIFO trigger level	UART_TLR[7-4] RX_FIFO_TRIG_DMA UART_FCR[7-6] RX_FIFO_TRIG	0x-
Set the register bit	UART_SCR[6] TX_TRIG_GRANU1	1
Set the desire TX FIFO trigger level	UART_TLR[3-0] TX_FIFO_TRIG_DMA UART_FCR[5-4] TX_FIFO_TRIG	0x-

13.1.4.5.5 UART Protocol, Baud rate and interrupt settings

13.1.4.5.5.1 Baud rate settings

Table 13-107. UART Baud Rate Settings

Step	Register/Bit Field/Programming Model	Value
Disable UART mode	UART_MDR1[2-0] MODE_SELECT	0x7
Switch to register configuration mode B	see Table 13-99	
Enable access to UART_IER_UART[7-4]	UART_EFR[4] ENHANCED_EN	1
Switch register operational mode	see Table 13-99	
Disable sleep mode	UART_IER_UART[4] SLEEP_MODE	0
Switch to register configuration mode A or B	see Table 13-99	
Set the appropriate divisor value	UART_DLL[7-0] CLOCK_LSB UART_DLH[5-0] CLOCK_MSB	0x-

13.1.4.5.5.2 Interrupt settings

Table 13-108. UART Interrupt Settings

Step	Register/Bit Field/Programming Model	Value
Switch to register configuration mode B	see Table 13-99	0x7
Enable access to UART_IER_UART[7-4]	UART_EFR[4] ENHANCED_EN	1
Switch register operational mode	see Table 13-99	
Set the desired interrupt configuration (0: Disable the interrupt; 1: Enable the interrupt)	UART_IER_UART[7] CTS_IT UART_IER_UART[6] RTS_IT UART_IER_UART[5] XOFF_IT UART_IER_UART[4] SLEEP_MODE UART_IER_UART[3] MODEM_STS_IT UART_IER_UART[2] LINE_STS_IT UART_IER_UART[1] THR_IT UART_IER_UART[0] RHR_IT	0x-

13.1.4.5.5.3 Protocol settings

Load the desired protocol formatting (parity, stop-bit, character length) and switch to register operational mode.

Table 13-109. UART Protocol Settings

Step	Register/Bit Field/Programming Model	Value
Load desired protocol formatting, see Section 13.1.4.4.8.1.5.1 , <i>Frame Formatting</i>	UART_LCR[5] PARITY_TYPE_2 UART_LCR[4] PARITY_TYPE_1 UART_LCR[3] PARITY_EN UART_LCR[2] NB_STOP UART_LCR[1-0] PARITY_LENGTH	0x-

Table 13-109. UART Protocol Settings (continued)

Step	Register/Bit Field/Programming Model	Value
Switch to register operational mode	UART_LCR[7] DIV_EN UART_LCR[6] BREAK_EN	0

13.1.4.5.5.4 UART/RS-485/IrDA(SIR/MIR/FIR)/CIR**Table 13-110. UART Mode Selection**

Step	Register/Bit Field/Programming Model	Value
Load the desired UART/IrDA (SIR, MIR, FIR)/CIR modes, see Section 13.1.4.4.7.2, UART/RS-485/IrDA (SIR, MIR, FIR)/CIR Mode Selection	UART_MDR1[2-0] MODE_SELECT	0x-
Load the desired RS-485 mode, see Section 13.1.4.4.7.2, UART/RS-485/IrDA (SIR, MIR, FIR)/CIR Mode Selection	UART_MDR3[4] DIR_EN	0x1

13.1.4.5.5.5 UART Multi-drop Parity Address Match Mode Configuration**Table 13-111. UART Multi-drop Parity Address Match Mode Configuration**

Step	Register/Bit Field/Programming Model	Value
Disable receive mode	UART_ECR[3] RX_EN	0
Enable Multi-drop parity Address match mode	UART_EFR2[2] MULTIDROP	1
Set the matching device address	UART_MAR[7-0] ADDRESS	0x-
Set the address match masking	UART_MMR[7-0] MASK	0x-
Set the broadcast address match	UART_MBR[7-0] BROADCAST_ADDRESS	0x-
Enable broadcast address matching if needed	UART_EFR2[7] BROADCAST	1
Enable receive mode	UART_ECR[3] RX_EN	1

13.1.4.5.6 UART Hardware and Software Flow Control Configuration

This section describes the programming steps to enable and configure hardware and software flow control. Hardware and software flow control cannot be used at the same time.

13.1.4.5.6.1 Hardware Flow Control Configuration**Table 13-112. UART Hardware Flow Control Configuration**

Step	Register/Bit Field/Programming Model	Value
Configure register submode TCR_TLR	see Table 13-100	0x7
Load the start and halt trigger value.	UART_TCR[7-4] AUTO_RTS_START UART_TCR[3-0] AUTO_RTS_HALT	0x-
Enable or disable receive and transmit hardware flow control mode.	UART_EFR[7] AUTO_CTS_EN UART_EFR[6] AUTO_RTS_EN	0x-

13.1.4.5.6.2 Software Flow Control Configuration**Table 13-113. UART Software Flow Control Configuration**

Step	Register/Bit Field/Programming Model	Value
Set the register access submode XOFF	see Table 13-102	
Load the software control characters	UART_XON1_ADDR1[7-0] XON_WORD1 UART_XON2_ADDR2[7-0] XON_WORD2 UART_XOFF1[7-0] XOFF_WORD1 UART_XOFF2[7-0] XOFF_WORD2	0x-
Set the register access submode TCR_TLR	see Table 13-100	
Enable or disable XON any function (0: Disable; 1: Enable).	UART_MCR[5] XON_EN	--

Table 13-113. UART Software Flow Control Configuration (continued)

Step	Register/Bit Field/Programming Model	Value
Load start and halt trigger value for software flow control	UART_TCR[7-4] AUTO_RTS_START UART_TCR[3-0] AUTO_RTS_HALT	0x-
Enable or disable special character function (0: Disable; 1: Enable)	UART_EFR[5] SPEC_CHAR	0x-
Set the software flow control mode	UART_EFR[3-0] SW_FLOW_CONTROL	0x-

13.1.4.5.7 IrDA Programming Model**13.1.4.5.7.1 SIR mode****13.1.4.5.7.1.1 Receive**

The following programming model explains how to program the module to receive an IrDA frame with parity forced to 1, baud rate = 115.2 kbps, FIFOs disabled, 2 stop-bits, and 8-bit word length:

Table 13-114. SIR Mode Receive Settings

Step	Register/Bit Field/Programming Model	Value
Disable UART mode	UART_MDR1[2-0] MODE_SELECT	0x7
Grant access to the UART_DLL and UART_DLH registers	UART_LCR[7-0]	0x80
Load the baud rate(115.2 Kbps)	UART_DLL[7-0] CLOCK_LSB UART_DLH[5-0] CLOCK_MSB	0x1A 0x00
Set SIR mode	UART_MDR1[2-0] MODE_SELECT	0x1
Disable access to the UART_DLL and UART_DLH registers	UART_LCR[7-0]	0x00
Enable the UART_RHR interrupt	UART_IER_IRDA[0] RHR_IT	1

13.1.4.5.7.1.2 Transmit

The following programming model explains how to program the module to transmit an IrDA 6-byte frame with no parity, baud rate = 115.2 kbps, FIFOs disabled, 3/16 encoding, 2 stop-bits, and 7-bit word length:

Table 13-115. SIR Mode Transmit Settings

Step	Register/Bit Field/Programming Model	Value
Disable UART mode	UART_MDR1[2-0] MODE_SELECT	0x7
Grant access to the UART_DLL and UART_DLH registers	UART_LCR[7-0]	0x80
Load the baud rate (115.2 Kbps)	UART_DLL[7-0] CLOCK_LSB UART_DLH[5-0] CLOCK_MSB	0x1A 0x00
Set SIR mode	UART_MDR1[2-0] MODE_SELECT	0x1
Disable access to the UART_DLL and UART_DLH registers	UART_LCR[7-0]	0x00
Force output DTR to active	UART_MCR[0] DTR	1
Enable the UART_THR interrupt	UART_IER_IRDA[1] THR_IT	0x1
Set transmit frame length to 6 bytes	UART_TXFLL[7-0] TXFLL	0x06
Set the seven starts of frame transmission	UART_EBLR[7-0] EBLR	0x08
Set SIR pulse width to be 1.6 μ s	UART_ACREG[7] PULSE_TYPE	1

13.1.4.5.7.2 MIR mode**13.1.4.5.7.2.1 Receive**

The following programming model explains how to program the module to receive an IrDA frame with no parity, baud rate = 1.152 Mbps, and FIFOs disabled.

Table 13-116. MIR Mode Receive Settings

Step	Register/Bit Field/Programming Model	Value
Disable UART mode	UART_MDR1[2-0] MODE_SELECT	0x7
Grant access to the UART_DLL and UART_DLH registers	UART_LCR[7-0]	0x80
Load the baud rate (1.152 bps)	UART_DLL[7-0] CLOCK_LSB	0x01
	UART_DLH[5-0] CLOCK_MSB	0x00
Set MIR mode	UART_MDR1[2-0] MODE_SELECT	0x4
Disable access to the UART_DLL and UART_DLH registers	UART_LCR[7-0]	0x00
Force outputs DTR and RTS to active	UART_MCR[1-0]	0x3
Enable the UART_RHR interrupt	UART_IER_IRDA[0] RHR_IT	1

13.1.4.5.7.2.2 Transmit

The following programming model explains how to program the module to transmit an IrDA 60-byte frame with no parity, baud rate = 1.152 Mbps, and FIFOs disabled.

Table 13-117. MIR Mode Transmit Settings

Step	Register/Bit Field/Programming Model	Value
Disable UART mode	UART_MDR1[2-0] MODE_SELECT	0x7
Grant access to the UART_DLL and UART_DLH registers	UART_LCR[7-0]	0x80
Load the baud rate (115.2 kbps)	UART_DLL[7-0] CLOCK_LSB	0x01
	UART_DLH[5-0] CLOCK_MSB	0x00
Set SIR mode	UART_MDR1[2-0] MODE_SELECT	0x4
Disable access to the UART_DLL and UART_DLH registers	UART_LCR[7-0]	0x00
Force output DTR to active	UART_MCR[0] DTR	1
Enable the UART_THR interrupt	UART_IER_IRDA[1] THR_IT	0x1
Set transmit frame length to 60 bytes	UART_TXFLL[7-0] TXFLL	0x3C
Set the eight additional starts of frame transmission	UART_EBLR[7-0] EBLR	0x08
SIP is sent at the end of transmission	UART_ACREG[3] SEND_SIP	1

13.1.4.5.7.3 FIR mode

13.1.4.5.7.3.1 Receive

The following programming model explains how to program the module to receive the IrDA frame with no parity, baud rate = 4 Mbps, FIFOs enabled, 8-bit word length.

Table 13-118. FIR Mode Receive Settings

Step	Register/Bit Field/Programming Model	Value
Disable UART mode	UART_MDR1[2-0] MODE_SELECT	0x7
Grant access to the UART_DLL and UART_DLH registers	UART_LCR[7-0]	0x80
Enable access to change UART_FCR[0]	UART_DLL[7-0] CLOCK_LSB	0x0
	UART_DLH[7-0] CLOCK_MSB	
FIFO clear and enable	UART_FCR[2-0]	0x7
Set the FIFO trigger level	see Section 13.1.4.5.4 , <i>Load FIFO trigger and DMA mode settings</i>	
Set FIR mode	UART_MDR1[2-0] MODE_SELECT	0x5
Set frame length	UART_RXFLL[7-0] RXFLL	0xA
Disable access to the UART_DLL and UART_DLH registers	UART_LCR[7-0]	0x00
Enable the UART_RHR interrupt	UART_IER_IRDA[0] RHR_IT	1

13.1.4.5.7.3.2 Transmit

The following programming model explains how to program the module to transmit an IrDA 4-byte frame with no parity, baud rate = 4 Mbps, FIFOs enabled, and 8-bit word length.

Table 13-119. FIR Mode Transmit Settings

Step	Register/Bit Field/Programming Model	Value
Disable UART mode	UART_MDR1[2-0] MODE_SELECT	0x7
Grant access to the UART_DLL and UART_DLH registers	UART_LCR[7-0]	0x80
Enable access to change UART_FCR[0]	UART_DLL[7-0] CLOCK_LSB UART_DLH[5-0] CLOCK_MSB	0x0
FIFO clear and enable	UART_FCR[2-0]	0x7
Set the FIFO trigger level	see Section 13.1.4.5.4, Load FIFO trigger and DMA mode settings	
Set FIR mode	UART_MDR1[2-0] MODE_SELECT	0x1
Disable access to the UART_DLL and UART_DLH registers	UART_LCR[7-0]	0x00
Set FIR mode and enable auto-SIP mode	UART_MDR1[7-0]	0x45
Set frame length	UART_TXFLL[7-0] TXFLL UART_TXFLH[7-0] TXFLH	0x4 0x0
Force output DTR to active	UART_MCR[0] DTR	1
Enable the UART_THR interrupt	UART_IER_IRDA[1] THR_IT	1
Set the eight additional starts of frame transmission	UART_EBLR[7-0] EBLR	0x08
SIP is sent at the end of transmission	UART_ACREG[3] SEND_SIP	1

13.2 High-speed Serial Interfaces

This section describes the high-speed serial interfaces in the device.



13.2.1 Gigabit Ethernet Switch (CPSW3G)

This chapter describes the Gigabit Ethernet Switch (CPSW3G) subsystem in the device.

13.2.1.1 CPSW0 Overview	1049
13.2.1.2 CPSW0 Environment	1054
13.2.1.3 CPSW0 Integration	1059
13.2.1.4 CPSW0 Functional Description	1063
13.2.1.5 CPSW0 Programming Guide	1151

13.2.1.1 CPSW0 Overview

The 3-port Gigabit Ethernet Switch (CPSW0) subsystem provides Ethernet packet communication for the device and can be configured as an Ethernet switch.

The device has one 3-port Gigabit Ethernet Switch subsystem named CPSW0 which supports two external Ethernet interfaces and one internal CPPI interface.

[Figure 13-92](#) shows the CPSW0 module overview.

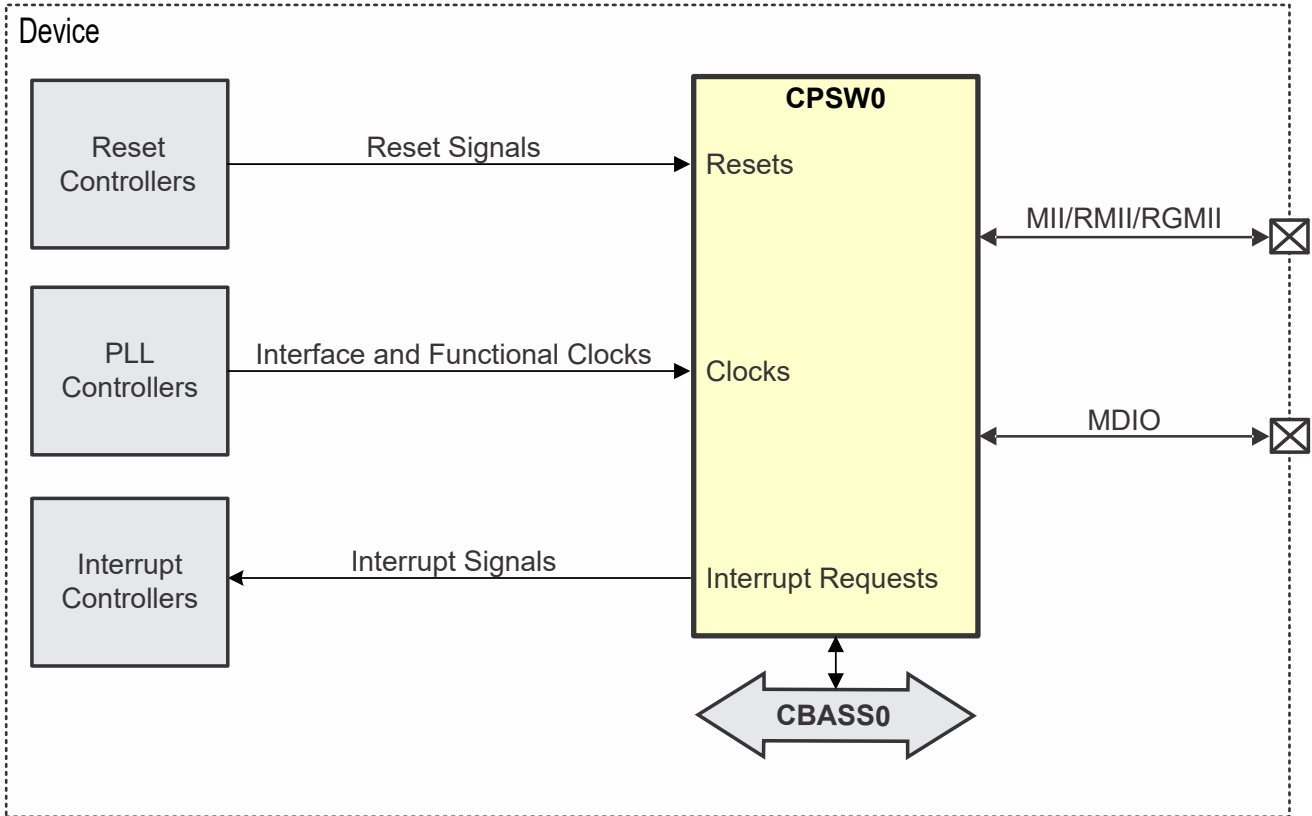

Figure 13-92. CPSW0 Overview

13.2.1.1.1 CPSW0 Features

The 3-port CPSW0 subsystem provides the following features:

- Two Ethernet ports (port 1 and 2) with selectable MII, RMII, and RGMII interfaces and an internal Communications Port Programming Interface (CPPI) port (Port 0)
- Synchronous 10/100/1000 Mbit operation
- Flexible logical FIFO-based packet buffer structure
- Eight priority level Quality Of Service (QOS) support (802.1p)
- Support for Audio/Video Bridging (P802.1Qav/D6.0)
- Support for IEEE 1588 Clock Synchronization (2008 Annex D, Annex E and Annex F)
 - Timestamp module capable of time stamping external timesync events like Pulse-Per-Second and also generating Pulse-Per-Second outputs
 - CPTS module that supports time stamping for IEEE1588 with support for 8 hardware push events and generation of compare output pulses
- DSCP Priority Mapping (IPv4 and IPv6)
- Energy Efficient Ethernet (EEE) support (802.3az)
- Flow Control Support (802.3x)
- Wire rate switching (802.1d)
- Non-Blocking switch fabric
- Time Sensitive Network Support
 - IEEE 802.1Qbv Enhancements for Scheduled Traffic
- Address Lookup Engine (ALE)
 - 512 ALE table entries
 - Configurable number of addresses plus VLANs
 - Wire rate lookup
 - Host controlled time-based aging and/or auto-aging
 - Spanning tree support
 - L2 address lock and L2 filtering support
 - MAC authentication (802.1x)
 - Receive-based or destination-based Multicast and Broadcast rate limits
 - MAC address blocking
 - Source port locking
 - OUI (Vendor ID) host accept/deny feature
 - Configurable number of classifier/policers (32)
 - VLAN support
 - 802.1Q compliant
 - Auto add port VLAN for untagged frames on ingress
 - Auto VLAN removal on egress and auto pad to minimum frame size
- EtherStats and 802.3Stats Remote Network Monitoring (RMON) statistics gathering (per port statistics)
- Ethernet Mac transmit to Ethernet Mac receive Loopback mode (digital loopback) supported
- Maximum frame size of 2024 bytes
- Management Data Input/Output (MDIO) module for PHY Management with Clause 45 support
- Programmable interrupt control with selected interrupt pacing
- Host port CPPI Streaming Packet Interface (CPPI_ICLK)
- Digital loopback and FIFO loopback modes supported
- Emulation support
- Full duplex mode supported in 10/100/1000 Mbps. Half-duplex mode supported only in 10/100 Mbps modes only.
- RAM Error Detection and Correction (SECCDED)

13.2.1.1.2 CPSW0 Not Supported Features

The following features are not supported by the CPSW0 switch:

- Maximum frame size of 9600 bytes
- GMII Mode

- SGMII Mode
- MACSEC
- Synchronous Ethernet
- Cut through with any form of flow control
- Cut through with 10/100 half-duplex
- Time Sensitive Network Support
 - IEEE P802.3br/D2.0 Interspersing Express Traffic

13.2.1.1.3 CPSW Terminology

Terminology:

AVB	Audio Video Bridging
AVBTP	Audio Video Bridging Transport Protocol
BMCA	Best Master Clock Algorithm
CFI	Canonical Format Indicator
CPPI	Communications Port Programming Interface
CPSW	Common Platform Switch
DLR	Device Level Ring
DSCP	Differentiated Services Code Point
EEE	Energy Efficient Ethernet
EMAC	Ethernet Media Access Control
EOP	End of Packet
EOQ	End of Queue
IPG	Inter-Packet Gap
LPI	Low Power Indicator
MDIO	Management Data Input/Output
MOF	Middle of Frame
OUI	Organizationally Unique Identifier
PFC	Priority based Flow Control
PTP	Precision Time Protocol
RMON	Remote Monitoring
RTCP	RTP Control Protocol
RTP	Real-time Transport Protocol
SCR	Switched Central Resource
SRP	Stream Reservation Protocol
TOS	Type of Service
VLAN	Virtual Local Area Network

13.2.1.2 CPSW0 Environment

This section describes the CPSW0 external connections (environment).

13.2.1.2.1 CPSW0 MII Interface

Figure 13-93 shows a device with integrated EMAC and MDIO interfaced via a MII connection in a typical system. The EMAC module does not include a transmit error (MTXER) pin. In the case of transmit error, CRC inversion is used to negate the validity of the transmitted frame.

The individual EMAC and MDIO signals for the MII interface are summarized in Table 13-120.

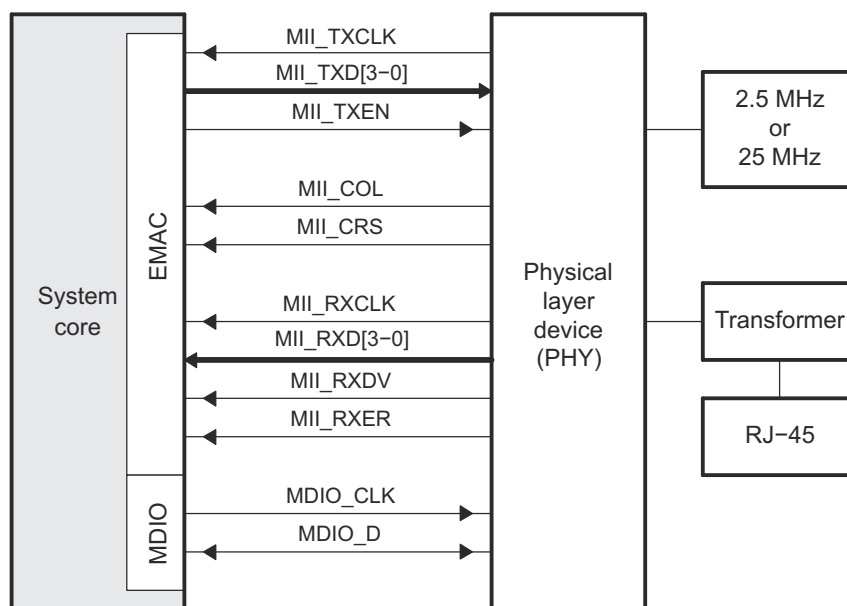

Figure 13-93. Ethernet Configuration—MII Connections

ADVANCE INFORMATION

Table 13-120. EMAC and MDIO Signals for MII Interface

Signal	Type	Description
MII_TXCLK	I	Transmit clock (MII_TXCLK). The transmit clock is a continuous clock that provides the timing reference for transmit operations. The MII_TXD and MII_TXEN signals are tied to this clock. The clock is generated by the PHY and is 2.5 MHz at 10 Mbps operation and 25 MHz at 100 Mbps operation.
MII_TXD[3-0]	O	Transmit data (MII_TXD). The transmit data pins are a collection of 4 data signals comprising 4 bits of data. MTDX0 is the least-significant bit (LSB). The signals are synchronized by MII_TXCLK and valid only when MII_TXEN is asserted.
MII_TXEN	O	Transmit enable (MII_TXEN). The transmit enable signal indicates that the MII_TXD pins are generating nibble data for use by the PHY. It is driven synchronously to MII_TXCLK.
MII_COL	I	Collision detected (MII_COL). In half-duplex operation, the MII_COL pin is asserted by the PHY when it detects a collision on the network. It remains asserted while the collision condition persists. This signal is not necessarily synchronous to MII_TXCLK nor MII_RXCLK. In full-duplex operation, the MII_COL pin is used for hardware transmit flow control. Asserting the MII_COL pin will stop packet transmissions; packets in the process of being transmitted when MII_COL is asserted will complete transmission. The MII_COL pin should be held low if hardware transmit flow control is not used.
MII_CRS	I	Carrier sense (MII_CRS). In half-duplex operation, the MII_CRS pin is asserted by the PHY when the network is not idle in either transmit or receive. The pin is deasserted when both transmit and receive are idle. This signal is not necessarily synchronous to MII_TXCLK nor MII_RXCLK. In full-duplex operation, the MII_CRS pin should be held low.
MII_RXCLK	I	Receive clock (MII_RXCLK). The receive clock is a continuous clock that provides the timing reference for receive operations. The MII_RXD, MII_RXDV, and MII_RXER signals are tied to this clock. The clock is generated by the PHY and is 2.5 MHz at 10 Mbps operation and 25 MHz at 100 Mbps operation.
MII_RXD[3-0]	I	Receive data (MII_RXD). The receive data pins are a collection of 4 data signals comprising 4 bits of data. MRDX0 is the least-significant bit (LSB). The signals are synchronized by MII_RXCLK and valid only when MII_RXDV is asserted.
MII_RXDV	I	Receive data valid (MII_RXDV). The receive data valid signal indicates that the MII_RXD pins are generating nibble data for use by the EMAC. It is driven synchronously to MII_RXCLK.
MII_RXER	I	Receive error (MII_RXER). The receive error signal is asserted for one or more MII_RXCLK periods to indicate that an error was detected in the received frame. This is meaningful only during data reception when MII_RXDV is active.
MDIO_CLK	O	Management data clock (MDIO_CLK). The MDIO data clock is sourced by the MDIO module on the system. It is used to synchronize MDIO data access operations done on the MDIO pin. The frequency of this clock is controlled by the CLKDIV bits in the MDIO control register (CONTROL).
MDIO_D	I/O	Management data input output (MDIO_D). The MDIO data pin drives PHY management data into and out of the PHY by way of an access frame consisting of start of frame, read/write indication, PHY address, register address, and data bit cycles. The MDIO_D pin acts as an output for all but the data bit cycles at which time it is an input for read operations.

13.2.1.2.2 CPSW0 RMII Interface

Figure 13-94 shows a device with integrated EMAC and MDIO interfaced via a RMII connection in a typical system. The individual CPSW0 and MDIO signals for the RMII interface are summarized in Table 13-121.

The CPSW0 module integrated in the device supports internal and external clock sources in RMII mode. Figure 13-94 shows the internal clock source for RMII_MHZ_50_CLK clock. It is 50 MHz clock source that is provided on the CLKOUT0 device pin. This clock has to be routed on the PCB to the RMII_REF_CLK device pin and the external PHY, RMII clock input.

For more information, refer to either the IEEE 802.3 standard or ISO/IEC 8802-3:2000(E).

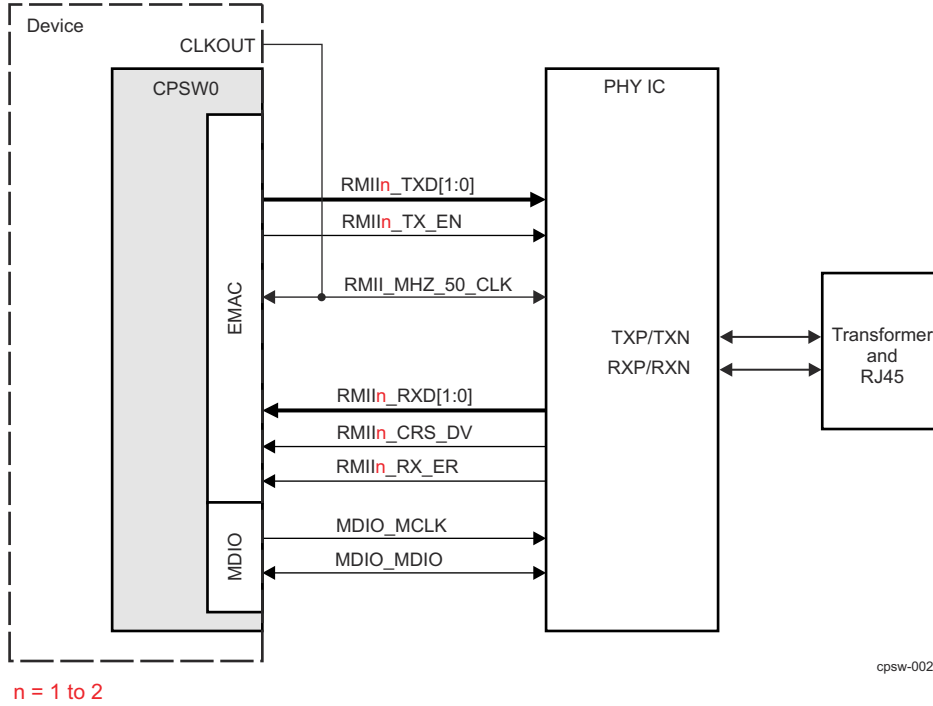

Figure 13-94. RMIi Interface Typical Application (Internal Clock Source)

Figure 13-95 shows the external clock source for RMIi_MHZ_50_CLK clock. In this case a 50 MHz clock is available on the PCB and it can be sourced from an oscillator or from the Ethernet PHY. This externally generated clock should be routed to both RMIi_REF_CLK device pin and the external PHY, RMIi clock input.

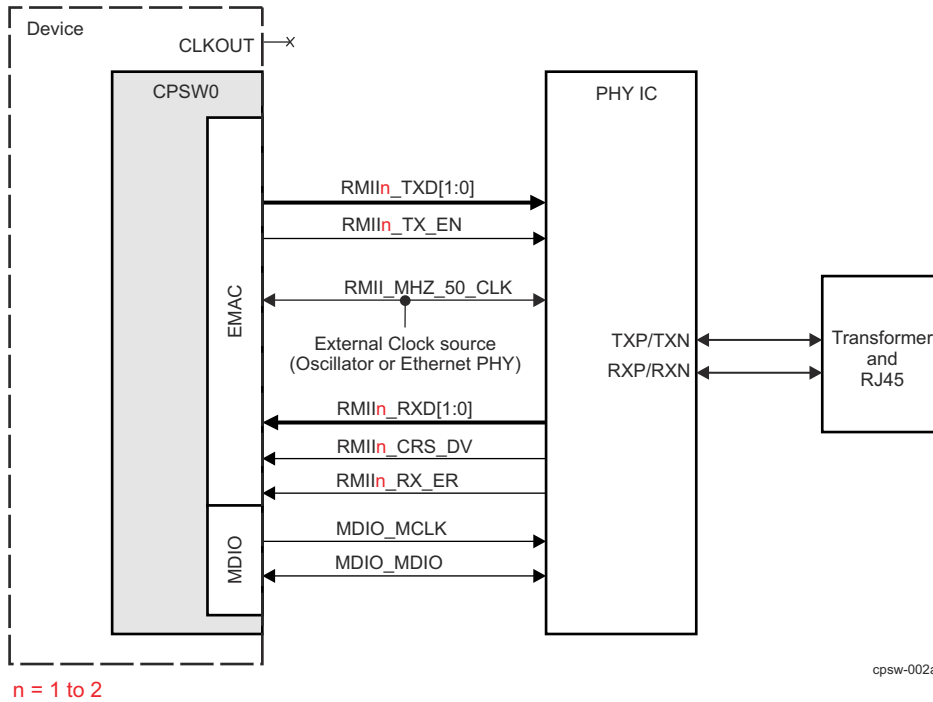

Figure 13-95. RMIi Interface Typical Application (External Clock Source)

ADVANCE INFORMATION

Table 13-121. RMII I/O Description

Signal ⁽²⁾	Device Pin(s)	I/O ⁽¹⁾	Description
RMII _n _TXD[1:0]	RMII _n _TXD[1:0]	O	Transmit data. The transmit data pins are a collection of 2 bits of data. TXD0 is the least-significant bit (LSB). The signals are synchronized by RMII_MHZ_50_CLK and valid only when RMII _n _TX_EN is asserted.
RMII _n _TX_EN	RMII _n _TX_EN	O	RMII transmit enable. The transmit enable signal indicates that the RMII _n _TXD[1:0] pins are generating data for use by the PHY. RMII _n _TX_EN is synchronous to RMII_MHZ_50_CLK.
RMII_MHZ_50_CLK	RMII_REF_CLK	I	RMII 50MHz reference clock. The reference clock is used to synchronize all RMII signals. RMII_MHZ_50_CLK must be continuous and fixed at 50 MHz.
RMII _n _RXD[1:0]	RMII _n _RXD[1:0]	I	Receive data. The receive data pins are a collection of 2 bits of data. RXD0 is the least-significant bit (LSB). The signals are synchronized by RMII_MHZ_50_CLK and valid only when RMII _n _CRS_DV is asserted and RMII _n _RX_ER is de-asserted.
RMII _n _CRS_DV	RMII _n _CRS_DV	I	Carrier sense/receive data valid. Multiplexed signal between carrier sense and receive data valid.
RMII _n _RX_ER	RMII _n _RX_ER	I	Receive error. The receive error signal is asserted to indicate that an error was detected in the received frame.
MDIO_MCLK	MDIO0_MDC	O	Management data clock (MDIO_MCLK). The MDIO data clock is sourced by the MDIO module on the system. It is used to synchronize MDIO data access operations done on the MDIO0_MDIO data pin.
MDIO_MDIO	MDIO0_MDIO	I/O	MDIO data pin drives PHY management data into and out of the PHY by way of an access frame consisting of start of frame, read/write indication, PHY address, register address, and data bit cycles. The MDIO0_MDIO pin acts as an output for all but the data bit cycles at which time it is an input for read operations.

(1) I = Input; O = Output
 (2) n 1 to 2

13.2.1.2.3 CPSW0 RGMII Interface

Figure 13-96 shows a device with integrated EMAC and MDIO interfaced via a RGMII connection in a typical system. The individual CPSW0 and MDIO signals for the RGMII interface are summarized in Table 13-122.

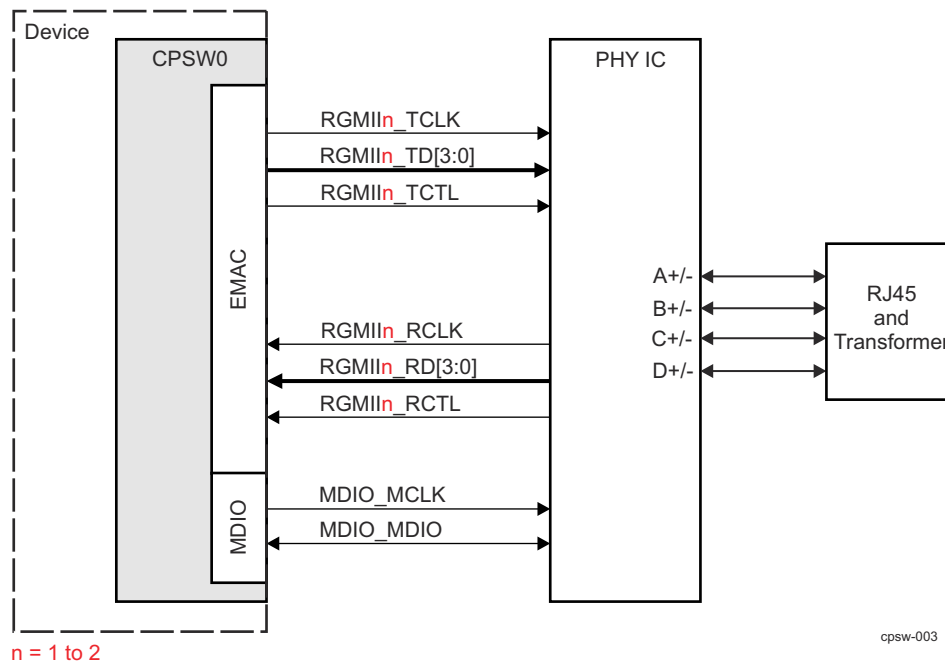

Figure 13-96. RGMII Interface Typical Application

Table 13-122. RGMII I/O Description

Signal ⁽²⁾	Device Pin(s)	I/O ⁽¹⁾	Description
RGMIIn_TD[3:0]	RGMIIn_TD[3:0]	O	The transmit data pins are a collection of 4 bits of data. TD0 is the least-significant bit (LSB). The signals are valid only when RGMIIn_TCTL is asserted.
RGMIIn_TCTL	RGMIIn_TX_CTL	O	Transmit Control/enable. The transmit enable signal indicates that the TD pins are generating data for use by the PHY.
RGMIIn_TCLK	RGMIIn_TXC	O	The transmit reference clock. The clock is 2.5 MHz at 10 Mbps operation, 25 MHz at 100 Mbps operation, and 125 MHz at 1000 Mbps of operation.
RGMIIn_RD[3:0]	RGMIIn_RD[3:0]	I	The receive data pins are a collection of 4 bits of data. RD0 is the least-significant bit (LSB). The signals are valid only when RGMIIn_RX_CTL is asserted
RGMIIn_RCTL	RGMIIn_RX_CTL	I	The receive data valid/control signal indicates that the RD pins are nibble data for use by the EMAC.
RGMIIn_RCLK	RGMIIn_RXC	I	The receive clock is a continuous clock that provides the timing reference for receive operations. The clock is generated by the PHY and is 2.5 MHz at 10 Mbps operation, 25 MHz at 100 Mbps operation, 125 MHz at 1000 Mbps of operation.
MDIO_MCLK	MDIO0_MDC	O	Management data clock (MDIO_MCLK). The MDIO data clock is sourced by the MDIO module on the system. It is used to synchronize MDIO data access operations done on the MDIO0_MDIO pin.
MDIO_MDIO	MDIO0_MDIO	I/O	The MDIO0_MDIO pin drives PHY management data into and out of the PHY by way of an access frame consisting of start of frame, read/write indication, PHY address, register address, and data bit cycles. The MDIO0_MDIO pin acts as an output for all but the data bit cycles at which time it is an input for read operations.

(1) I = Input; O = Output

(2) n 1 to 2

Note

The Control Module registers assign the specific function to the device pads. For more information on Control Module settings, see Pad Configuration Registers in *Control Module (CTRL_MMR)* and the device-specific Datasheet.

13.2.1.3 CPSW0 Integration

This section describes modules integration in the device, including information about clocks, resets, and hardware requests.

13.2.1.3.1 CPSW3G Integration

There is 1x CPSW3G module integrated in the device. The diagram below provides a visual representation of the device integration details.

ADVANCE INFORMATION

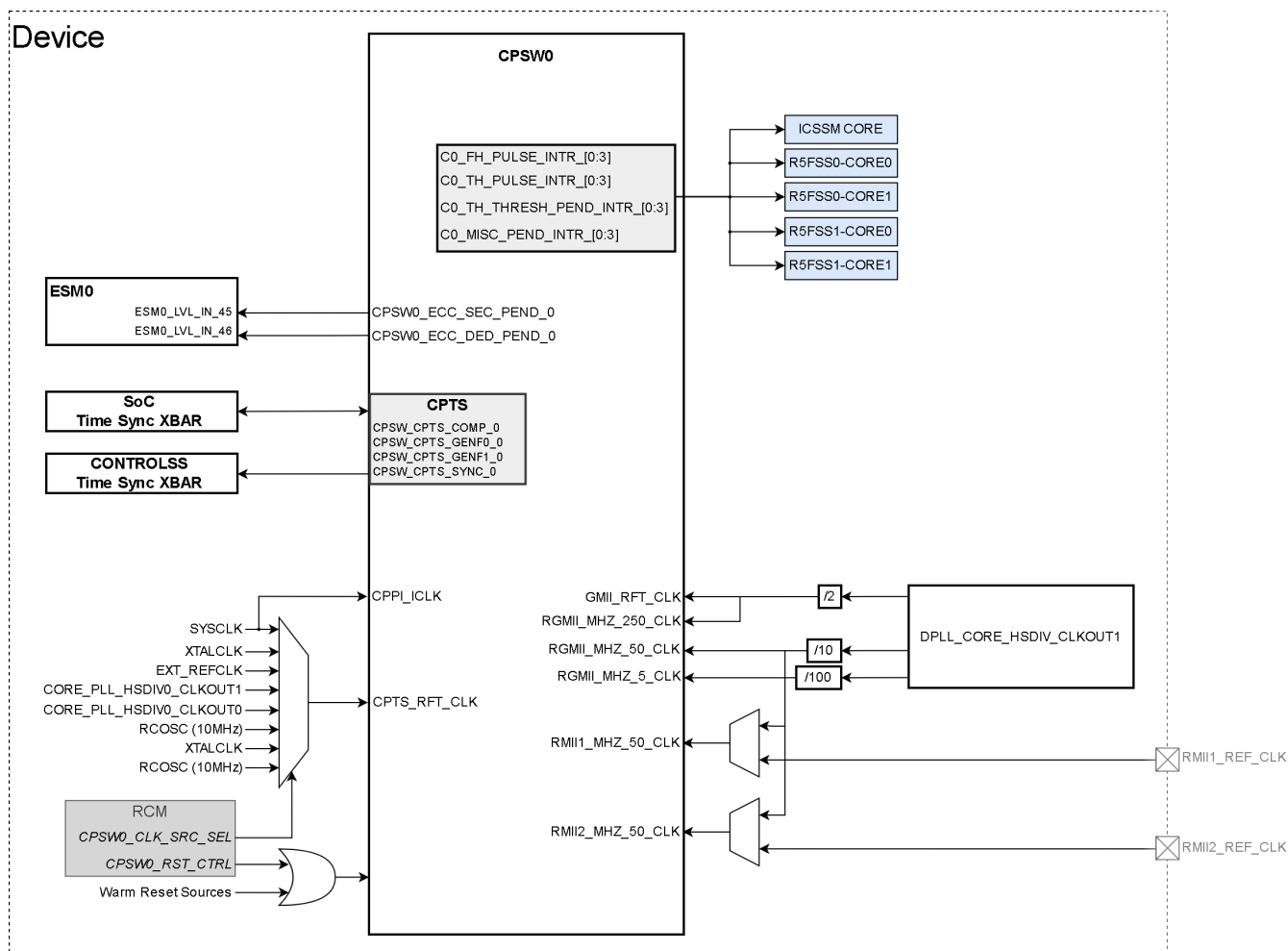

Figure 13-97. CPSW3G Integration Diagram

The tables below summarize the device integration details of CPSW0.

Table 13-123. CPSW0 Device Integration

This table describes the module device integration details.

Module Instance	Device Allocation	SoC Interconnect
CPSW0	✓	INFRA0 VBUSP Interconnect

Table 13-124. CPSW0 Clocks

This table describes the module clocking signals.

Module Instance	Module Clock Input	Source Clock Signal	Source	Default Freq	Description	
CPSW0	CPPI_ICLK	SYS_CLK	PLL_CORE_CLK: HSDIV0_CLKOUT0	200 MHz	CPSW0 Interface Clock	
	CPTS_RFT_CLK	XTACLK	XTACLK	External XTAL	25 MHz	CPSW0 Interface Clock
		EXT_REFCLK	EXT_REFCLK	External Reference Clock (EXT_REFCLK)	100 MHz	CPSW0 Interface Clock
		SYS_CLK	SYS_CLK	PLL_CORE_CLK: HSDIV0_CLKOUT0	200 MHz	CPSW0 Interface Clock
		DPLL_CORE_HSDIV0_CLKOUT1	DPLL_CORE_HSDIV0_CLKOUT1	PLL_CORE_CLK: HSDIV0_CLKOUT1	500 MHz	CPSW0 Interface Clock
		DPLL_CORE_HSDIV0_CLKOUT0	DPLL_CORE_HSDIV0_CLKOUT0	PLL_CORE_CLK: HSDIV0_CLKOUT0	400 MHz	CPSW0 Interface Clock
		RCCLK10M	RCCLK10M	Internal 10 MHz RC Oscillator (RCCLK10M)	10 MHz	CPSW0 Interface Clock
		XTALCLK	XTALCLK	External XTAL	25 MHz	CPSW0 Interface Clock
		RCCLK10M	RCCLK10M	Internal 10 MHz RC Oscillator (RCCLK10M)	10 MHz	CPSW0 Interface Clock
	GMII_RFT_CLK	RGMII_250_CLK	RGMII 250 MHz Clock	250 MHz	CPSW0 Interface Clock	
	RMII1_MHZ_50_CLK	RGMII_50_CLK	RGMII 50 MHz Clock	50 MHz	CPSW0 Interface Clock	
		RMII1_REF_CLK	RMII1 Reference Clock	50 MHz ¹	CPSW0 Interface Clock	
	RMII2_MHZ_50_CLK	RGMII_50_CLK	RGMII 50 MHz Clock	50 MHz	CPSW0 Interface Clock	
		RMII2_REF_CLK	RMII2 Reference Clock	50 MHz ¹	CPSW0 Interface Clock	
	RGMII_MHZ_50_CLK	RGMII_50_CLK	RGMII 50 MHz Clock	50 MHz	CPSW0 Interface Clock	
	RGMII_MHZ_5_CLK	RGMII_5_CLK	RGMII 5 MHz Clock	5 MHz	CPSW0 Interface Clock	
	RGMII_MHZ_250_CLK	RGMII_250_CLK	RGMII 250 MHz Clock	250 MHz	CPSW0 Interface Clock	

Note

¹The RMIIx_REF_CLK input pin can be drive by an external clock reference source. 50 MHz is required for proper operation.

Table 13-125. CPSW0 Resets

This table describes the module reset signals.

Module Instance	Module Reset Input	Source Reset Signal	Source	Description
CPSW0	CPSW_RST	Warm Reset (MOD_G_RST)	RCM + Warm Reset Sources	CPSW0 Asynchronous Reset

Table 13-126. CPSW0 Interrupt Requests

This table describes the module interrupt requests.

Module Instance	Module Interrupt Signal	Destination Interrupt Input	Destination	Type	Description
CPSW0	C0_FH_PULSE_INTR[0:3]	C0_FH_PULSE_INTR	All R5FSS Cores ICSSM Core	Level	FHost (from host to Ethernet) paced pulse interrupt
	C0_TH_PULSE_INTR[0:3]	C0_TH_PULSE_INTR	All R5FSS Cores ICSSM Core	Level	THost (from Ethernet to host) paced pulse interrupt
	C0_TH_THRESH_PEND_INTR[0:3]	C0_TH_THRESH_PEND_INTR	All R5FSS Cores ICSSM Core	Level	THost (from Ethernet to host) non-paced pulse interrupt
	C0_MISC_PEND_INTR[0:3]	C0_MISC_PEND_INTR	All R5FSS Cores ICSSM Core	Level	Miscellaneous non-paced pulse interrupt
	CPSW_ECC_SEC_PEND_INTR	ECC_SEC_PEND_INTR	ESM	Level	ECC SEC pulse interrupt – output from CPSW ECC module.
	CPSW_ECC_DED_PEND_INTR	ECC_DED_PEND_INTR	ESM	Level	ECC DED pulse interrupt – output from CPSW ECC module.

Table 13-127. CPSW0 Time Sync and Compare Event

This table describes the module capture event inputs.

Module Instance	Module Event	Destination Event Input	Destination	Type	Description
CPSW0	CPSW0_CPTS_COMP	SoC_TimeSyncXBAR[0:3]	CPSW0_CPTS_COMP_INTR	Level	CPSW0 Compare Event Interrupt
		C2K_TimeSyncXBAR[0:3]			
	CPSW0_CPTS_GENF0	SoC_TimeSyncXBAR[0:3]	CPSW0_CPTS_GENF0_INTR	Level	CPSW0 CPTS generator function event interrupt 0
		C2K_TimeSyncXBAR[0:3]			
	CPSW0_CPTS_GENF1	SoC_TimeSyncXBAR[0:3]	CPSW0_CPTS_GENF1_INTR	Level	CPSW0 CPTS generator function event interrupt 1
		C2K_TimeSyncXBAR[0:3]			
	CPSW0_CPTS_SYNC	SoC_TimeSyncXBAR[0:3]	CPSW0_CPTS_SYNC_INTR	Level	CPSW0 CPTS Sync Event Interrupt
		C2K_TimeSyncXBAR[0:3]			

Note

For more information on the interconnects, see the *System Interconnect* chapter.

For more information on power, reset, and clock management, see the corresponding sections within the *Device Configuration* chapter.

For more information on the device interrupt controllers, see the *Interrupt Controllers* chapter.

For pin information on RGMII_ID_MODE and RGMII_REFCLK_SEL, see Register information and the corresponding section within the *Device Configuration* chapter

13.2.1.4 CPSW0 Functional Description

The three-port switch Ethernet subsystem module (CPSW) is compliant to the IEEE Std 802.3 Specification. CPSW top level functional block diagram is shown in [Figure 13-98](#).

13.2.1.4.1 Functional Block Diagram

The three-port Ethernet subsystem consists of:

- CPSW3G Peripheral Core
- One RGMII_n (where n = 1 to 2) interface module
- One RMII_n (where n = 1 to 2) interface module
- One MII_n (where n = 1 to 2) interface module
- One Host Port 0 CPPI Packet Streaming Interface
- CPSW subsystem control registers (REG)
- One MDIO interface module
- One Interrupt Controller module

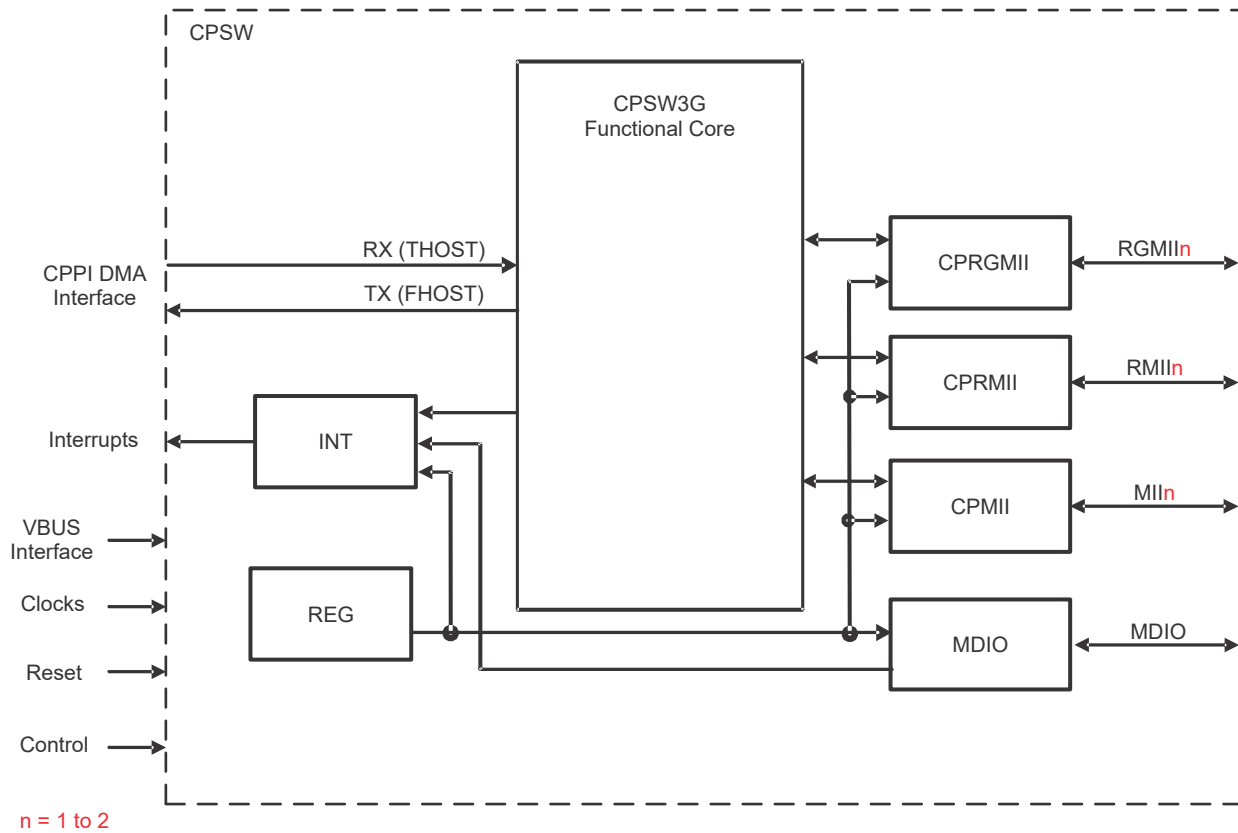

Figure 13-98. CPSW Top Level Block Diagram

13.2.1.4.2 CPSW Ports

The Ethernet Subsystem has three ports. Port 0 is the Host port (internal to the Subsystem). Port 1 and 2 are the external ports connected to RGMII, RMII, MII interfaces as per the interface selected.

Naming conventions followed in this chapter:

- Port0 is referred to the CPPI Host Port
- Port1 and 2 are referred to the interfaces RGMII/RMII/MII

13.2.1.4.2.1 Interface Mode Selection

The three-port switch (CPSW) Ethernet Subsystem has one 10/100/1000 Ethernet port with selectable RMII, RGMII, and MII interfaces.

The interface modes for all 2 Ethernet ports are selected by configuring the Ethernet interface mode selection bitfield (PORT_MODE_SEL) in the CTRLMMR_ENET1_CTRL and CTRLMMR_ENET2_CTRL registers.

See the device-specific Datasheet for configuring the pin mux mode as per the interface selected.

13.2.1.4.3 Clocking

13.2.1.4.3.1 Subsystem Clocking

CPSW clocking summary is shown in *CPSW Integration*.

13.2.1.4.3.2 Interface Clocking

Data is transmitted and received with respect to the reference clocks of the interface pins.

13.2.1.4.3.2.1 RGMII Interface Clocking

RGMII_RXC, RGMII_TXC frequencies are:

- 2.5 MHz at 10 Mbps
- 25 MHz at 100 Mbps
- 125 MHz at 1000 Mbps

Note

RGMII has ID_MODE for TX internal delay that can be controlled in register MSS_CTRL:CPSW_CONTROL

13.2.1.4.3.2.2 RMII Interface Clocking

RMII interface clock RMII_50MHZ_CLK frequency is:

- 50 MHz at 10 Mbps
- 50 MHz at 100 Mbps

For more details on RMII clocking, please see , *CPSW0 Integration*

CTRLMMR_CLKOUT_CTRL[4]CLK_EN and CTRLMMR_CLKOUT_CTRL[0]CLK_SEL bits are used to enable and select the clock source for CLKOUT device pin.

13.2.1.4.3.2.3 MDIO Clocking

The MDIO clock is based on a divide-down of the interface (CPPI_ICLK) clock. The application software or driver must control the divide-down value.

See the CPSW_MDIO_CONTROL_REG register for configuring the Clock Divider ([15-0]CLKDIV) value.

13.2.1.4.4 Software IDLE

The submodule software idle register bits enable CPSW operation to be completely or partially suspended by software control. There are two CPSW submodules that contain software idle register bits. Each of the two submodules may be individually commanded to enter the idle state. The idle state is entered at packet boundaries, and no further packet operations will occur on an idled submodule until the idle command is

removed. The CPSW module enters the idle state when all two submodules are commanded to enter and have entered the idle state. Idle status is determined by reading or polling the two submodule idle bits. The CPSW_3G is in the idle state when all two submodules are in the idle state. The CPSW_SOFT_IDLE_REG[0] SOFT_IDLE bit may be set if desired after the submodules are in the idle state. The SOFT_IDLE bit causes packets to not be transferred from one FIFO to another FIFO internal to the switch.

13.2.1.4.5 Interrupt Functionality

CPSW Ethernet Subsystem has six interrupt outputs:

- Cn_FH_PEND_INTR - FHost (from host to Ethernet) level interrupt
- Cn_TH_PEND_INTR - THost (from Ethernet to host) level interrupt
- Cn_TH_THRESH_PEND_INTR - THost (from Ethernet to host) non-paced level interrupt
- Cn_MISC_PEND_INTR - Miscellaneous non-paced pending interrupt
- ECC_SEC_PEND_INTR: ECC SEC pending interrupt - from CPSW ECC module. This interrupt is also included in the C0_MISC_PEND_INTR if enabled or can be used separately if desired.
- ECC_DED_PEND_INTR: ECC DED pending interrupt - from CPSW ECC module. This interrupt is also included in the C0_MISC_PEND_INTR if enabled or can be used separately.

Note

n = 0 to \$num_cores-1

13.2.1.4.6 CPSW_3G

The CPSW_3G RMII/ RGMII interface is compliant to the IEEE Std 802.3 Specification.

The CPSW_3G contains two Ethernet port interfaces (Ethernet port 1 and 2), one CPPI packet streaming interface host port (port 0), Common Platform Time Sync (CPTS), ALE Engine and Statistics (STATS). A top-level block diagram of the CPSW_3G is shown in [Figure 13-99](#).

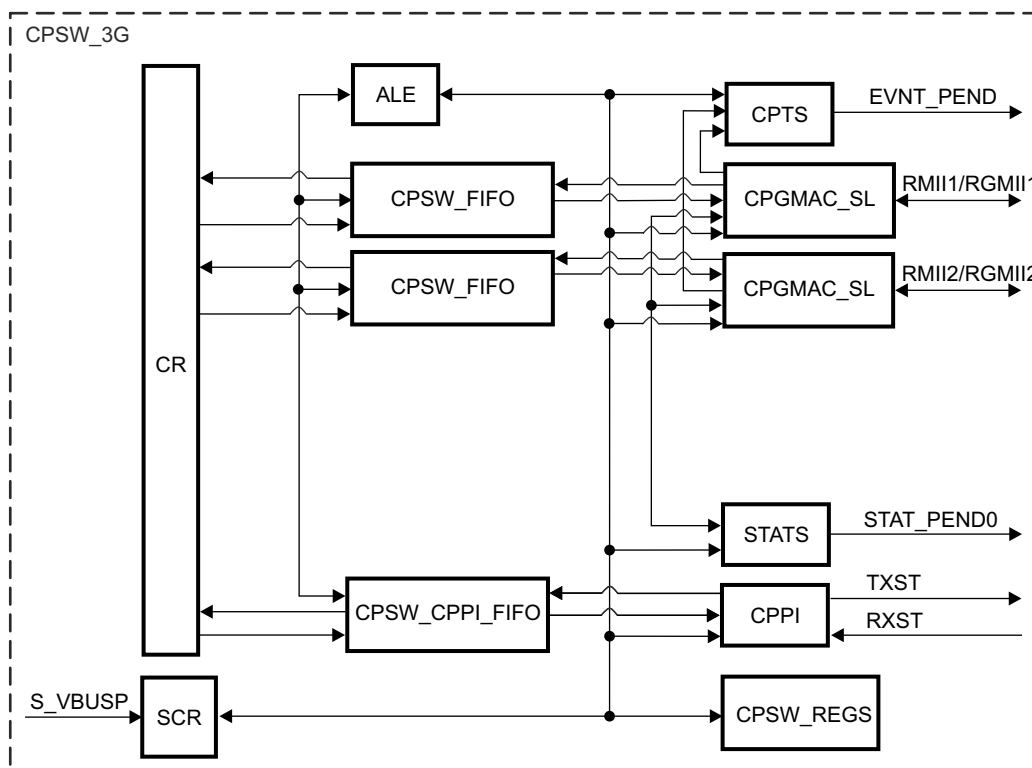

Figure 13-99. CPSW_3G Block Diagram

13.2.1.4.6.1 Address Lookup Engine (ALE)

The Address Lookup Engine (ALE) is a sub-block of the CPSW Switch and it processes all received packets and determines to which port(s) the packet should be forwarded. The ALE uses the incoming packet received port number, destination address, source address, length/type, and VLAN information to determine how the packet should be forwarded. The ALE outputs the port mask to the switch fabric that indicates the port(s) the packet should be forwarded to. The ALE is enabled when the ENABLE_ALE bit in the CPSW_ALE_CONTROL register is set. All packets are dropped when the ENABLE bit is cleared to 0.

13.2.1.4.6.1.1 Error Handling

In normal operation, the Ethernet port modules are configured drop received packages that contain errors (runt, frag, oversize, jabber, crc, alignment, code etc.). However, when the CPSW_PN_MAC_CONTROL_REG_k configuration bit(s) RX_CEF_EN, RX_CSF_EN, or RX_CMF_EN are set, received Ethernet packages with errors are transferred to the host. When the ALE receives a packet that contains errors (due to a set header error bit), or a MAC control frame and does not receive an abort, the packet will be forwarded only to the host port (port 0). Packets with errors that are forwarded to the host have no VLAN untagging or drop due to rate limiting. No ALE learning occurs on packets with errors or mac control frames. Learning is based on source address and lookup is based on destination address. Directed packets from the host are not learned, updated, or touched.

13.2.1.4.6.1.2 Bypass Operations

The ALE may be configured to operate in bypass mode by setting the ENABLE_BYPASS bit in the CPSW_ALE_CONTROL register. When in bypass mode, all Ethernet port received packets are forwarded only to the host port (port 0). In bypass mode, the ALE processes host port transmit packets the same as in normal mode. In general, packets would be directed by the host in bypass mode.

13.2.1.4.6.1.3 OUI Deny or Accept

The ALE may be configured to operate in OUI deny mode by setting the ENABLE_OUI_DENY bit in the CPSW_ALE_CONTROL register. When in OUI deny mode, a packet with a non-matching OUI source address will be dropped unless the destination address matches a multicast table entry with the SUPER bit set. When ENABLE_OUI_DENY bit is cleared, any packet source address matching an OUI address table entry will be dropped to the host unless the destination address matches with a supervisory address table entry. Broadcast packets will be dropped unless the broadcast address is entered into the table with the SUPER bit set. Unicast packets will be dropped unless the unicast address is in the table with BLOCK and SECURE both set (supervisory unicast packet).

13.2.1.4.6.1.4 Statistics Counting

ALE sends many statistics along with the frame routing so the CPSW can count them on a per port basis. There are many reasons to drop frames the below drop events are individually counted in CPSW per port statistics counters. For more information on ALE statistics please refer to section [Section 13.2.1.4.6.17](#)

13.2.1.4.6.1.5 Automotive Security Features

The ALE has many automotive security features that most enterprise switches do not require.

- VLANs can be configured to not allow fragmented IPv4 frames. That is a VLAN can be configured to not allow fragmented IPv4 traffic.
- VLANs can be configured to only allow up to four different IPv4 Protocols or IPv6. Next Header values, for example a VLAN can be configured to only allow TCP traffic in both IPv4 and IPv6 packets.
- Drop invalid Source Addresses, that is drop Source Addresses with bit 40 set (Multicast/Broadcast indicator on Destination Addresses)
- IEEE802.3 Length Check, drop frames that the IEEE802.3 Length is not contained within the frame. (Ether Types 0-1500)
- Any Source Address can be secured to a port dropping any attempts from other ports to masquerade as a service.
- Any source or destination address can be blocked.
- Per Port or Per VLAN ingress checking, dropping traffic from non-member ports.
- Classification, Policing on L2 and L3 information.

13.2.1.4.6.1.6 CPSW Switching Solutions

The host port can operate in many different modes as well depending on the functionality of the host. It is important to understand the modes and configure them properly.

The ALE Table is designed to maximize the modes without compromise of the system functionality as well.

13.2.1.4.6.1.6.1 Basics of 3-port Switch Type

The 3-port switch has a host port, and that port can operate in two fundamental modes. Bridge mode allows the host to extend the switched domain to another network like Wi-Fi or another multi-port switch. In this case the host must be able to see unknown unicast addresses so they can be broadcast to the other network. In Port mode the host need not see any unknown unicast traffic. The CPSW_ALE_CONTROL[8] EN_HOST_UNI_FLOOD bit determines the host mode for unknown unicast traffic. This bit should only be set if the user is bridging two or more networks together.

The 3-port switch can operate like a two-port switch using the ALE table just for the host info, the only adder is now other VLANs need to be supported for transit traffic between the external ports. This can easily be done using the default VLAN rules so no ALE table entries are used.

The 3-port switch can also operate in a fully authenticated environment where all network nodes are registered via the 802.1x based protocols. In this case the ALE table is filled with network node addresses that have been authenticated

13.2.1.4.6.1.7 VLAN Routing and OAM Operations

13.2.1.4.6.1.7.1 InterVLAN Routing

The CPSW module supports wire rate InterVLAN routing for a small number of routes, that is the host will setup an ALE classifier with an associated egress operation that will cause the CPSW to perform particular egress operations. The ALE can optionally check time to live validity as well.

The ALE uses the classifier along with an egress opcode, destination port mask and TTL check field to tell the CPSW to manipulate the packet on the egress. The CPSW will use the opcode along with a per port operation table to process the packet. By setting up the CPSW egress operation table you can replace the DA, SA and VLAN along with optionally updating the time to live IP header field. This allows the CPSW to perform the routing function for a small set of routes without getting the local host/CPU involved.

The Egress opcode will only be use for a classifier match and the packet would normally be sent only to the host. That is the host would have routed the packet but the CPSW has been configured to do the work instead. In the event that the time-to-live check feature is enabled and the time-to-live is either 0 or 1, the packet will not get the egress opcode and instead be sent to the host as if the route is not setup. This allows the host to deal with invalid TTL fields.

13.2.1.4.6.1.7.2 OAM Operations

The ALE supports OAM loopback on ports so that a remote link can be tested. That is a port placed in OAM loopback will echo packets received on a port back to the port with an egress op of 0xFF which will swap the SA and DA on egress in the CPSW.

Any supervisory packet will not be affected, so the spanning tree and other bridging functions are not affected.

Packets will only be echoed if the port is in OAM loopback mode, the received packet in not a supervisor packet. The port is in a forwarding state and the packet received DA!=SA and there are no errors in the packet.

When a port is in OAM loopback the port will not egress traffic from other ports, no address for loop backed traffic will be learned if enabled. Any packet received on the OAM loopback port with an error will be process as if the port is not in OAM. That is if the host has enabled copy errored frames the errored frames will be sent to the host instead.

13.2.1.4.6.1.8 Supervisory packets

Multicast supervisory packets are designated by the SUPER bit in the table entry. Unicast supervisory packets are indicated when BLOCK and SECURE are both set. Supervisory packets are not dropped due to rate limiting,

OUI, or VLAN processing. The purpose of supervisory packets is to allow packets that would be otherwise blocked to be forwarded for special purposes.

13.2.1.4.6.1.9 Address Table Entry

The ALE table contains multiple table entry types. Each table entry represents a free entry, an address, a VLAN, an address/VLAN pair, or an OUI address. Software should ensure that there are not double address entries in the table. The double entry used would be indeterminate. Reserved table bits must be written with zeroes.

Source Address learning occurs for packets with a unicast, multicast or broadcast destination address and a unicast or multicast (including broadcast) source address. Multicast source addresses have the group bit (bit 40) cleared before ALE processing begins, changing the multicast source address to a unicast source address. A multicast address of all ones is the broadcast address which may be added to the table. A learned unicast source address is added to the table with the following control bits:

Table 13-128. Learned Address Control Bits

Bit(s)	Value
Ageable	1
Touch	1
BLOCK	0
SECURE	0

If a received packet has a source address that is equal to the destination address then the following occurs:

- The address is learned if the address is not found in the table.
- The address is updated if the address is found.
- The packet is dropped.

Table Entry Type

00 - Free Entry

01 - Address Entry : unicast or multicast determined by destination **address bit 40**.

10 - VLAN entry

11 - VLAN Address Entry : unicast or multicast determined by **address bit 40**.

13.2.1.4.6.1.9.1 Multicast Address Table Entry

Table 13-129. Multicast Address Table Entry Bit Values

70:68	67:66	65	64	63:62	61:60	59:48	47:0
Reserved	PORT_MASK	SUPER	Reserved	MCAST_FWD_STATE	ENTRY_TYPE (01)	Reserved	MULTICAST_ADDRESS

Supervisory Packet (SUPER)

When set, this field indicates that the packet with a matching multicast destination address is a supervisory packet.

0: Non-supervisory packet

1: Supervisory packet

Port Mask(1:0) (PORT_MASK)

This 2-bit field is the port bit mask that is returned with a found multicast destination address. There may be multiple bits set indicating that the multicast packet may be forwarded to multiple ports (but not the receiving port).

Multicast Forward State (MCAST_FWD_STATE)

Indicates the port state(s) required for the received port on a destination address lookup in order for the multicast packet to be forwarded to the transmit port(s). A transmit port must be in the Forwarding state in order to forward the packet. If the transmit PORT_MASK has multiple set bits then each forward decision is independent of the other transmit port(s) forward decision.

00 - Forwarding

01 - Blocking/Forwarding/Learning

10 - Forwarding/Learning

11 - Forwarding

The forward state test returns a true value if both the RX and TX ports are in the required state.

Table Entry Type (ENTRY_TYPE)

Address entry type. Unicast or multicast determined by address bit 40.

01: Address entry. Unicast or multicast determined by address bit 40.

Packet Address (MULTICAST_ADDRESS)

This is the 48-bit packet MAC address. For an OUI address, only the upper 24-bits of the address are used in the source or destination address lookup. Otherwise, all 48-bits are used in the lookup.

13.2.1.4.6.1.9.2 OUI Unicast Address Table Entry

Table 13-130. OUI Unicast Address Table Entry Bit Values

70:64	63:62	61:60	59:48	47:24	23:0
Reserved	UNICAST_TYPE (10)	ENTRY_TYPE (01)	Reserved	UNICAST_OUI	Reserved

Unicast Type (UNICAST_TYPE)

This field indicates the type of unicast address the table entry contains.

00 - Unicast address that is not ageable.

01 - Ageable unicast address that has not been touched.

10 - OUI address - lower 24-bits are don't cares (not ageable).

11 - Ageable unicast address that has been touched.

Table Entry Type (ENTRY_TYPE)

Address entry. Unicast or multicast determined by address bit 40.

01: Address entry. Unicast or multicast determined by address bit 40.

Packet Address (UNICAST_OUI)

For an OUI address, only the upper 24-bits of the address are used in the source or destination address lookup.

13.2.1.4.6.1.9.3 Unicast Address Table Entry (Bit 40 == 0)

Table 13-131. Unicast Address Table Entry Bit Values

70:69	68	67:66	65	64	63	62	61:60	59:48	47:0
RESERVED	TRUNK	PORT_NUMBER	BLOCK	SECURE	TOUCH	AGEABLE	ENTRY_TYPE (3h)	RESERVED	UNICAST_ADDRESS

Trunk Indicator (TRUNK)

0h = The port bits in the entry are the port number

1h = The port bits in the entry are the trunk number

Port Number (PORT_NUMBER)

This field indicates the port number (not port mask) that the packet with a unicast destination address may be forwarded to. Packets with unicast destination addresses are forwarded only to a single port (but not the receiving port).]

Block (BLOCK)

The block bit indicates that a packet with a matching source or destination address should be dropped (block the address).

0h = Address is not blocked.

1h = Drop a packet with a matching source or destination address (secure must be zero)

If block and secure are both set, then they no longer mean block and secure. When both are set, the block and secure bits indicate that the packet is a unicast supervisory (super) packet and they determine the unicast forward state test criteria. If both bits are set then the packet is forwarded if the receive port is in the Forwarding/Blocking/Learning state. If both bits are not set then the packet is forwarded if the receive port is in the Forwarding state.

Secure (SECURE)

This bit indicates that a packet with a matching source address should be dropped if the received port number is not equal to the table entry PORT_NUMBER.

0h = Received port number is a don't care.

1h = Drop the packet if the received port is not the secure port for the source address and do not update the address (block must be zero)

Touch Indicator (TOUCH)

Only valid when AGEABLE is a 1h.

0h = Ageable unicast address has not been touched

1h = Ageable unicast address that has been touched

Ageable (AGEABLE)

This bit indicates that the address is ageable.

0h = Unicast address that is not ageable

1h = Unicast address that is ageable

Table Entry Type (ENTRY_TYPE)

Address entry. Unicast or multicast determined by address bit 40.

01: Address entry. Unicast or multicast determined by address bit 40.

Packet Address (UNICAST_ADDRESS)

This is the 48-bit packet MAC address. All 48-bits are used in the lookup.

13.2.1.4.6.1.9.4 Multicast Address Table Entry (Bit 40==1)

Table 13-132. Multicast Address Table Entry Bit Values

70:69	68:66	65	64	63:62	61:60	59:48	47:0
RESERVED	PORT_MASK	SUPER	IGNMBITS	FWDSTLVL	ENTRY_TYPE (1h)	RESERVED	MULTICAST_A DDRESS

Port Mask(2:0) (PORT_MASK)

This 3-bit field is the port bit mask that is returned with a found multicast destination address. There may be multiple bits set indicating that the multicast packet may be forwarded to multiple ports (but not the receiving port).

Supervisory Packet (SUPER)

When set, this field indicates that the packet with a matching multicast destination address is a supervisory packet.

0: Non-supervisory packet

1: Supervisory packet

Ignore Multicast Bits (IGNMBITS)

Indication that the Multicast Address has ignored bits.

Forward State Level (FWDSTLVL)

Indicates the port state(s) required for the received port on a destination address lookup in order for the multicast packet to be forwarded to the transmit port(s).

A transmit port must be in the Forwarding state in order to forward the packet. If the transmit port_mask has multiple set bits then each forward decision is independent of the other transmit port(s) forward decision.

0h = Forwarding

1h = Blocking/Forwarding/Learning

2h = Forwarding/Learning

3h = Forwarding

The forward state test returns a true value if both the RX and TX ports are in the required state.

Table Entry Type (ENTRY_TYPE)

Address entry type. Unicast or multicast determined by address bit 40.

01: Address entry. Unicast or multicast determined by address bit 40.

Packet Address (MULTICAST_ADDRESS)

This is the 48-bit packet MAC address. For an OUI address, only the upper 24-bits of the address are used in the source or destination address lookup. Otherwise, all 48-bits are used in the lookup.

13.2.1.4.6.1.9.5 VLAN/Unicast Address Table Entry (Bit 40 == 0)

Table 13-133. Unicast Address Table Entry Bit Values

70:69	68	67:66	65	64	63	62	61:60	59:48	47:0
RESERVED	TRUNK	PORT_NUMBER	BLOCK	SECURE	TOUCH	AGEABLE	ENTRY_TYPE (3h)	VLAN_ID	UNICAST_ADDRESS

Trunk Indicator (TRUNK)

0h = The port bits in the entry are the port number

1h = The port bits in the entry are the trunk number

Port Number (PORT_NUMBER)

This field indicates the port number (not port mask) that the packet with a unicast destination address may be forwarded to. Packets with unicast destination addresses are forwarded only to a single port (but not the receiving port).]

Block (BLOCK)

The block bit indicates that a packet with a matching source or destination address should be dropped (block the address).

0h = Address is not blocked.

1h = Drop a packet with a matching source or destination address (secure must be zero)

If block and secure are both set, then they no longer mean block and secure. When both are set, the block and secure bits indicate that the packet is a unicast supervisory (super) packet and they determine the unicast forward state test criteria. If both bits are set then the packet is forwarded if the receive port is in the Forwarding/Blocking/Learning state. If both bits are not set then the packet is forwarded if the receive port is in the Forwarding state.

Secure (SECURE)

This bit indicates that a packet with a matching source address should be dropped if the received port number is not equal to the table entry PORT_NUMBER.

0h = Received port number is a don't care.

1h = Drop the packet if the received port is not the secure port for the source address and do not update the address (block must be zero)

Touch Indicator (TOUCH)

Only valid when AGEABLE is a 1h.

0h = Ageable unicast address has not been touched

1h = Ageable unicast address that has been touched

Ageable (AGEABLE)

This bit indicates that the address is ageable.

0h = Unicast address that is not ageable

1h = Unicast address that is ageable

Table Entry Type (ENTRY_TYPE)

Address entry. Unicast or multicast determined by address bit 40.

3h: VLAN address entry. Unicast or multicast determined by address bit 40.

VLAN ID (VLAN_ID)

The unique identifier for VLAN identification. This is the 12-bit VLAN ID.

Packet Address (UNICAST_ADDRESS)

This is the 48-bit packet MAC address. All 48-bits are used in the lookup.

13.2.1.4.6.1.9.6 VLAN/Multicast Address Table Entry (Bit 40==1)

Table 13-134. VLAN/Multicast Address Table Entry Bit Values

70:69	68:66	65	64	63:62	61:60	59:48	47:0
RESERVED	PORT_MASK	SUPER	IGNMBITS	FWDSTLVL	ENTRY_TYPE (11)	VLAN_ID	MULTICAST_AD DRESS

Port Mask(2:0) (PORT_MASK)

This 3-bit field is the port bit mask that is returned with a found multicast destination address. There may be multiple bits set indicating that the multicast packet may be forwarded to multiple ports (but not the receiving port).

Supervisory Packet (SUPER)

When set, this field indicates that the packet with a matching multicast destination address is a supervisory packet.

0: Non-supervisory packet

1: Supervisory packet

Ignore Multicast Bits (IGNMBITS)

Indication that the Multicast Address has ignored bits.

Forward State Level (FWDSTLVL)

Indicates the port state(s) required for the received port on a destination address lookup in order for the multicast packet to be forwarded to the transmit port(s).

A transmit port must be in the Forwarding state in order to forward the packet. If the transmit port_mask has multiple set bits then each forward decision is independent of the other transmit port(s) forward decision.

0h = Forwarding

1h = Blocking/Forwarding/Learning

2h = Forwarding/Learning

3h = Forwarding

The forward state test returns a true value if both the RX and TX ports are in the required state.

Table Entry Type (ENTRY_TYPE)

Address entry type. Unicast or multicast determined by address bit 40.

11: VLAN address entry. Unicast or multicast determined by address bit 40.

VLAN ID (VLAN_ID)

The unique identifier for VLAN identification. This is the 12-bit VLAN ID.

Packet Address (MULTICAST_ADDRESS)

This is the 48-bit packet MAC address. For an OUI address, only the upper 24-bits of the address are used in the source or destination address lookup. Otherwise, all 48-bits are used in the lookup.

13.2.1.4.6.1.9.7 Inner VLAN Table Entry

Table 13-135. Inner VLAN Table Entry

70:69	68:66	65	64:62	61:60	59:48	47	46:39	38:36
RESERVED	NO_LEARN_M ASK	VLAN_FORCE _INGRESS_C HECK	0h	ENTRY_TYPE (1h)	VLAN_ID	NOFRAG	RESERVED	REG_MCAST_F LOOD_INDEX
35:27	26:24	23	22:15	14:12	11:3	2:0		
RESERVED	FORCE_UNTAGGE D_EGRESS	LMTNXTHDR	RESERVED	UREGMSK	RESERVED	VLAN_MEMBER_LI ST		

No Learn Mask (NO_LEARN_MASK)

When a bit is set in this mask, a packet with an unknown source address received on the associated port will not be learned (i.e. When a VLAN packet is received and the source address is not in the table, the source address will not be added to the table).

VLAN Force Ingress Check (VLAN_FORCE_INGRESS_CHECK)

If the receive port is not a member of this VLAN then the packet is dropped. This is similar to the `ly_REG_Py_VID_INGRESS_CHECK` bit in the `CPSW_ly_ALE_PORTCTL0_y` registers except this check is for this VLAN only (not all VLANs).

Table Entry Type (ENTRY_TYPE)

2h: VLAN entry

VLAN ID (VLAN_ID)

The unique identifier for VLAN identification. This is the 12-bit VLAN ID.

(NOFRAG)

VLAN No IPv4 Fragmented frames Control - Causes IPv4 fragmented IP frames to be dropped.

Registered Multicast Flood Index (REG_MCAST_FLOOD_INDEX)

This field indicates which port(s) are the registered multicast flood mask.

Force Untagged Packet Egress (FORCE_UNTAGGED_EGRESS)

This field causes the packet VLAN tag to be removed on egress for the specified port(s) (except on port 0).

VLAN Limit Next Header Control (LMTNXTHDR)

This bit causes frames to be dropped if the Protocol/Nxt Header does not match the CPSW_ALE_NXT_HDR register values.

VLAN Unregister Multicast Mask (UREGMSK)

This field indicates which port(s) are the unregistered multicast flood mask.

VLAN Member List (VLAN_MEMBER_LIST)

This field indicates which port(s) are members of the associated VLAN. One bit per port.

13.2.1.4.6.1.9.8 Outer VLAN Table Entry

Table 13-136. Outer VLAN Table Entry

70:69	68:66	65	64:62	61:60	59:48	47	46:39	38:36
RESERVED	NO_LEARN_M ASK	VLAN_FORCE _INGRESS_C HECK	2h	ENTRY_TYPE (2h)	VLAN_ID	NOFRAG	RESERVED	REG_MCAST_F LOOD_INDEX
35:27	26:24	23	22:15	14:12	11:3	2:0		
RESERVED	FORCE_UNTAGGE D_EGRESS	LMTNXTHDR	RESERVED	UREGMSK	RESERVED	VLAN_MEMBER_LI ST		

No Learn Mask (NO_LEARN_MASK)

When a bit is set in this mask, a packet with an unknown source address received on the associated port will not be learned (i.e. When a VLAN packet is received and the source address is not in the table, the source address will not be added to the table).

VLAN Force Ingress Check (VLAN_FORCE_INGRESS_CHECK)

If the receive port is not a member of this VLAN then the packet is dropped. This is similar to the `ly_REG_Py_VID_INGRESS_CHECK` bit in the `CPSW_ly_ALE_PORTCTL0_y` registers except this check is for this VLAN only (not all VLANs).

Table Entry Type (ENTRY_TYPE)

2h: VLAN entry

VLAN ID (VLAN_ID)

The unique identifier for VLAN identification. This is the 12-bit VLAN ID.

(NOFRAG)

VLAN No IPv4 Fragmented frames Control - Causes IPv4 fragmented IP frames to be dropped.

Registered Multicast Flood Index (REG_MCAST_FLOOD_INDEX)

Index into CPSW_ALE_MSK_MUX0 to CPSW_Ix_ALE_MSK_MUXx register array that is used to create the registered multicast flood mask.

Force Untagged Packet Egress (FORCE_UNTAGGED_EGRESS)

This field causes the packet VLAN tag to be removed on egress for the specified port(s) (except on port 0).

VLAN Limit Next Header Control (LMTNXTHDR)

This bit causes frames to be dropped if the Protocol/Nxt Header does not match the CPSW_ALE_NXT_HDR register values.

VLAN Unregister Multicast Mask (UREGMSK)

This field indicates which port(s) are the unregistered multicast flood mask.

VLAN Member List (VLAN_MEMBER_LIST)

This field indicates which port(s) are members of the associated VLAN. One bit per port.

13.2.1.4.6.1.9.9 EtherType Table Entry

Table 13-137. EtherType Table Entry

70:65	64:62	61:60	59:16	15:0
RESERVED	4h	ENTRY_TYPE (2h)	RESERVED	ETHERTYPE

Table Entry Type (ENTRY_TYPE)

2h: VLAN entry

Ether Type (ETHERTYPE)

16-bits Ether Type field.

13.2.1.4.6.1.9.10 IPv4 Table Entry

Table 13-138. IPv4 Table Entry

70	69:65	64:62	61:60	59:32	31:0
RESERVED	IGNMBITS	6h	ENTRY_TYPE (2h)	RESERVED	IPV4ADR

Ignore Multicast Bits (IGNMBITS)

Indication that the Multicast Address has ignored bits.

Table Entry Type (ENTRY_TYPE)

2h: VLAN entry

IPv4 Address (IPV4ADR)

32-bit IPv4 Address. Any ignored bits must be zero value in the table entry.

13.2.1.4.6.1.9.11 IPv6 Table Entry High

Table 13-139. IPv6 Table Entry High

70:64	63	62	61:60	59:0
IGNMBITS	RESERVED	(1h)	ENTRY_TYPE (2h)	IPV6ADR[127:68]

Ignore Multicast Bits (IGNMBITS)

Indication that the Multicast Address has ignored bits.

Table Entry Type (ENTRY_TYPE)

2h: VLAN entry

IPv6 Address - upper 64 bits (IPV6ADR[127:68])

This address is split into three fields in the IPv6 High and IPv6 Low table entry. Any ignored bits must be zero in the table entry(s).

13.2.1.4.6.1.9.12 IPv6 Table Entry Low

Table 13-140. IPv6 Table Entry Low

70:63	62	61:60	59:0
IPV6ADR[67:60]	1h	ENTRY_TYPE (2h)	IPV6ADR[59:0]

Table Entry Type (ENTRY_TYPE)

2h: VLAN entry

IPv6 Address - upper 8 bits (IPV6ADR[67:60])

IPv6 Address - upper 60 bits (IPV6ADR[59:0])

This address is split into three fields in the IPv6 High and IPv6 Low table entry. Any ignored bits must be zero in the table entry(s).

Note: IPV6 table address entries operate differently than all other table entry types. IPV6 table entries have a high entry concatenated with a low entry. The high entry must have an entry_pointer value of the low entry_pointer plus 0x40. Bit six of the entry_pointer must be set for the high entry and must be zero for the low entry.

13.2.1.4.6.1.10 Multicast Address

Multicast addresses are addresses with bit 40 set. Only destination addresses can be Multicast addresses. The group bit (bit 40) of the source address is reserved in the IEEE standard.

A multicast address of all ones is the broadcast address which can be added to the lookup table if forwarding of broadcast packets need be modified.

13.2.1.4.6.1.10.1 Multicast Ranges

Added IgnMbits to indicate at least one bit of the multicast address is ignored. Up to 10 bits of the multicast address can be ignored to provide the ability to create multiple multicast address ranges.

```
if ((IgnMbits)&(MultiCastAddress[0]==0x000)) { MultiCastAddress[0] is ignored in compare}
if ((IgnMbits)&(MultiCastAddress[1:0]==0x001)) { MultiCastAddress[1:0] is ignored in compare}
if ((IgnMbits)&(MultiCastAddress[2:0]==0x003)) { MultiCastAddress[2:0] is ignored in compare}
if ((IgnMbits)&(MultiCastAddress[3:0]==0x007)) { MultiCastAddress[3:0] is ignored in compare}
if ((IgnMbits)&(MultiCastAddress[4:0]==0x00F)) { MultiCastAddress[4:0] is ignored in compare}
if ((IgnMbits)&(MultiCastAddress[5:0]==0x01F)) { MultiCastAddress[5:0] is ignored in compare}
if ((IgnMbits)&(MultiCastAddress[6:0]==0x03F)) { MultiCastAddress[6:0] is ignored in compare}
if ((IgnMbits)&(MultiCastAddress[7:0]==0x07F)) { MultiCastAddress[7:0] is ignored in compare}
if ((IgnMbits)&(MultiCastAddress[8:0]==0x0FF)) { MultiCastAddress[8:0] is ignored in compare}
if ((IgnMbits)&(MultiCastAddress[9:0]==0x1FF)) { MultiCastAddress[9:0] is ignored in compare}
```

Below is 'C' code to modify ALE MultiCastAddress and IgnMbits when iNumOfBitsToIgnore is greater than zero. Where fGenMask(iOffset,iBitsToMask) creates a Mask for the value provided. For example fGenMast(0,5) will return 0x1F.

```
if (iNumOfBitsToIgnore)
{
```

```

int iIgnClrMsk, iIgnSetMsk;
iIgnClrMsk=fGenMask(0, iNumOfBitsToIgnore);
iIgnSetMsk=fGenMask(0, iNumOfBitsToIgnore -1);
MultiCastAddress &= ~iIgnClrMsk;
MultiCastAddress |= iIgnSetMsk;
IgnMbits = 1;
}
else
{
IgnMbits = 0;
}

```

Multicast Addresses or Ranges can overlap, in the event of an overlap; the higher ALE index will be used.

13.2.1.4.6.1.11 Aging and Auto Aging

The ALE supports software control or automatic aging of agable addresses.

Any time an agable address is seen as a source address entering from a port the source address entry will be marked as touched.

If the aging timer expires or the software sets the [29] AGE_OUT_NOW bit in the CPSW_ALE_CONTROL, the aging process will be started.

The aging process will read each ALE entry and for all entries that are an address with or without VLAN that is also agable, the touch check process will be done.

The touch check process will test the TOUCH bit and if clear, the entry will be marked as free, else the TOUCH bit will be cleared.

What this means is that if the aging interval was programmed as one second, any unused entry could stay in the ALE table for 1.000001 to 1.999999 seconds

13.2.1.4.6.1.12 ALE Policing and Classification

The ALE has a number of configurable classifier engines (policers) that can be used for classification.

Classification is a subset of the policing function and uses a policer without the color marking or rate limiting functions. A policer is a hardware engine that is used for policing. The POLCNTDIV8 field in the CPSW_ALE_STATUS register indicates the number of policers available to be used for classification. Each policer can be enabled to match on one or more of any of the below packet fields for classification. All but Port and Priority are index references to the ALE table entries.

- Port Number
- Priority extracted from VLAN, mapped from DSCP if enabled, or Default Port Priority
- Organization Network Unique identifier - ONU
- Destination Address - DA
- Source Address - SA
- Outer VLANID -S-VLANID
- Inner VLANID -C-VLANID
- Ether Type
- IP Source Address - IPSA with full CIDR masking for IPv4 and IPv6
- IP Destination Address - IPSA with full CIDR masking for IPv4 and IPv6
- Support Host Thread/Flow ID mapping based on any packet classification above

13.2.1.4.6.1.12.1 ALE Policing

The policing function on each policer engine is implemented as dual-counter three-color marking engine as described in the IETF RFC2698. The first counter is the Committed Information Rate (CIR) counter and the second counter is the Peak Information Rate (PIR) counter. The policing function can use either or both counters. Based on the counter values the packet color is determined. The color is used to determine whether the packet is dropped or forwarded. The ALE has a local feature that can drop packets regardless of queue state.

The policing rates are determined by the below equations:

$$\text{CIR policing rate in Mbit/s} = ((\text{ALE frequency in Mhz}) * \text{CPSW_ALE_POLICECFG7}[31-0] \text{ CIR_IDLE_INC_VAL}) / 32768$$

$$\text{PIR policing rate in Mbit/s} = ((\text{ALE frequency in Mhz}) * \text{CPSW_ALE_POLICECFG6}[31-0] \text{ PIR_IDLE_INC_VAL}) / 32768$$

Each policer has 10 different match operations (see [Section 13.2.1.4.6.1.12](#)). Since multiple policing entries can be hit on a single packet this provides the ability to create precise traffic stream control.

Packets are colored at ALE lookup time. Packets can be colored RED, YELLOW, or GREEN. If multiple policers are configured for a packet stream then the packet color is merged from all matching (hit) policers. If any policer is RED then the packet is marked RED. Else if any policer is YELLOW then the packet is marked YELLOW. Otherwise the packet is marked GREEN.

The Policing engine supports several modes such that packets that don't hit a policing/classifier match can be treated as RED, YELLOW, GREEN or policer 0 color. Using policer 0 allows for a system to regulate unregulated traffic.

13.2.1.4.6.1.12.2 Classifier to Host Thread Mapping

The ALE module allows Host Thread mapping based on any packet classification. That is the ALE can generate a thread ID used by the host based on ALE classifier matches.

When enabled the highest classifier match can map to a particular thread ID value.

The ALE also supports an optional default Thread ID value in the event that no classifier match.

Each Thread ID, including the default thread ID, has an enable functionality such that, if no classifier matches occur the default value is used, if the default is not enabled, the switch will use the {port,priority} value instead. If multiple classifier matches occur, the highest matching entry with a thread enable bit set will be used.

Three registers are used for ALE classification thread mapping configuration (CPSW_ALE_THREADMAPDEF, CPSW_ALE_THREADMAPCTL and CPSW_ALE_THREADMAPVAL). The three thread mapping registers are used independently and are separate from the other ALE policing registers. The CPSW_ALE_THREADMAPCTL register allows the CPSW_ALE_THREADMAPVAL register contents to be written to the selected classifier. There is a CPSW_ALE_THREADMAPDEF register that is used for all classifiers. The thread mapping registers can be written or changed at any time but any packets that are already processed will not have their thread altered.

13.2.1.4.6.1.12.3 ALE Classification

When the policers are configured as classifiers, the color marking and policing functions of the policing/classifier engines are not used. One or multiple classifiers can be configured to match on a single packet. For example, a classifier can be enabled to match on priority while another classifier could match IP address.

2.1.4.6.1.12.3.1 Classifier to CPPI Transmit Flow ID Mapping

The ALE can generate a 6-bit transmit CPPI Flow ID based on classifier matches that can be used instead of the switch default transmit Flow ID mapping. The switch default flow ID is the remapped received packet priority (0 to 7). Thread and flow ID are used interchangeably for this since there is a single hardware thread (TXST_THREAD_MREADY) but there are 6-bits of FLOW_ID in the transmit CPPI INFO word 0. When enabled, the highest classifier match can map to a particular 6-bit flow ID value that is associated with the classifier. The

ALE also supports an optional ALE default thread/flow ID value in the event that no classifiers match. Each thread/flow ID, including the ALE default thread/flow ID, has an enable such that the ALE default thread/Flow ID is used if enabled and if no matches occur (instead of the remapped received packet priority). If the ALE default is not enabled and no matches occur then the switch default value will be used. If multiple classifier matches occur, the highest match with a thread enable bit set will be used. The resultant flow ID has the CPSW_P0_FLOW_ID_OFFSET_REG register value added to it to determine the actual value in the INFO 0 Flow ID field.

Three registers are used for ALE classification thread/flow ID mapping configuration (CPSW_ALE_THREADMAPDEF, CPSW_ALE_THREADMAPCTL and CPSW_ALE_THREADMAPVAL). The three thread mapping registers are used independently and are separate from the other ALE policing registers. The CPSW_ALE_THREADMAPCTL register allows the CPSW_ALE_THREADMAPVAL register contents to be written to the selected classifier. There is a single CPSW_ALE_THREADMAPDEF that is used for all classifiers. The thread mapping registers can be written or changed at any time but any packets that are already processed will not have their thread altered.

13.2.1.4.6.1.13 Mirroring

The ALE supports three mirroring modes: destination port, source port and or table entry.

Destination port mirroring allows packets from any ingress port or trunk which ends up switching to a particular egress destination port or trunk to be mirrored to yet another egress destination port or trunk. For example any traffic from any port that is switched to port 'A' can be also mirrored to port 'B'. (MIRROR_DP=A, MIRROR_DEN=1h, MIRROR_TOP=B in the CPSW_ALE_CONTROL register).

Source port mirroring allows packets received on any enabled ingress source port or trunk to be switched to the mirror egress port as well as the actual egress destination ports. For example traffic received on ingress port 'A' can be switched to egress port 'B' as well as the intended egress destination port. (ly_REG_Py_MIRROR_SP=1h in the CPSW_ly_ALE_PORTCTL0_y register, MIRROR_SEN=1h, MIRROR_TOP=B in the CPSW_ALE_CONTROL register).

Table entry mirroring allows for any MAC Address, MAC Address with VLAN, ONU Address or VLAN entry that matches on ingress to be switched to the egress destination as well as the actual egress destination. For example all traffic for VLAN ID of 35 can be mirrored to port 'B'. That is any traffic switched on VLAN ID of 35 will be mirrored. ({VLAN ID of 35 in ALE Table entry index=C}, MIRROR_MIDX=C, MIRROR_MEN=1h, MIRROR_TOP=B)

In the event that mirrored packets are mirrored to or from a port that is also the mirror port the packet will not be duplicated or marked as a mirror packet since the packet has already been on the port as ingress or egress. The packet sent to the mirror port may have modified VLAN info based on the port and VLAN lookup table entries. The mirror port need not be a member of the VLAN ID it is mirroring, the ALE will forward traffic to the mirror port after ingress and egress filters are applied.

The switch may decide to drop any mirror traffic based on switch buffer thresholds as to prevent required traffic from becoming congested.

Port mirroring is controlled by register fields in CPSW_ALE_CONTROL, CPSW_ALE_CTRL2 and the port control registers.

- MIRROR_DP - The destination port that will have its traffic mirrored (CPSW_ALE_CONTROL register).
- MIRROR_TOP - The port to which mirrored traffic is sent (CPSW_ALE_CONTROL register).
- MIRROR_MEN - The enable for mirroring traffic that matches a supported lookup table entry (CPSW_ALE_CONTROL register).
- MIRROR_DEN - The Enable for destination port mirroring (CPSW_ALE_CONTROL register).
- MIRROR_SEN - The Enable for source port mirroring (CPSW_ALE_CONTROL register).
- MIRROR_MIDX - The index of a lookup table entry that will be mirrored CPSW_ALE_CTRL2 register).
- ly_REG_Py_MIRROR_SP - The enable for the Source port to be mirrored. Although multiple source ports can be mirrored concurrently, a mirror traffic bandwidth issue may occur on the mirror egress port (CPSW_ly_ALE_PORTCTL0_y register).

13.2.1.4.6.1.14 Trunking

The ALE supports port trunking of any port in any of four trunk groups. That is, four trunk groups can be supported with up to eight ports in each trunk group. There are no port adjacency rules for trunk groups. When ports are a member of a trunk group, addresses added and used in the lookup table will refer to the trunk group rather than port as indicated in the lookup table entries. If ports are removed from a trunk group, the ALE will redistribute the traffic based on the crc polynomial of enabled fields and the remaining ports within the trunk group. A trunk group may contain only one port. Packet priority, DA, SA, C-VLAN ID, IPv4SA, IPv4DA, IPv6SA, and/or IPv6DA can be used in the hash to generate destination port within the trunk group. If all hash enables are disabled, the packet can be directed to a particular port within the trunk group which allows for testing paths etc. A host directed frame is directed to the directed port regardless of trunk group settings.

Trunking is controlled through fields in the CPSW_ALE_CTRL2 register and in each ALE CPSW_ly_ALE_PORTCTL0_y register:

- TRK_EN_DST - Enable destination address hashing for trunk port calculation.
- TRK_EN_SRC - Enable source address hashing for trunk port calculation.
- TRK_EN_PRI - Enable priority hashing for trunk port calculation.
- TRK_EN_IVLAN - Enable inner C-VLAN ID hashing for trunk port calculation.
- TRK_EN_SIP - Enable source IP address hashing for trunk port calculation.
- TRK_EN_DIP - Enable destination IP address hashing for trunk port calculation.
- TRK_BASE - Hashing formula starting value and test port offset.
- ly_REG_Py_TRUNKEN - Enable this port as a trunk group
- ly_REG_Py_TRUNKNUM - Trunk group number defines this port as a member of a particular trunk group.

13.2.1.4.6.1.15 DSCP

The ALE can map DSCP field to priority prior to classification matching. When enabled the DSCP is mapped via 64 priority entries such that any DSCP value can be mapped to any of the eight priorities. When a packet is received without a VLAN priority this remapped priority can be used instead of the default Port VLAN priority field. See CPSW_P0_RX_DSCP_MAP_REG_y and CPSW_PN_RX_DSCP_MAP_REG_y registers in the Register Manual section for DSCP mapping.

13.2.1.4.6.1.16 Packet Forwarding Processes

There are four processes that an incoming received packet may go through to determine packet forwarding. The processes are *Ingress Filtering*, *VLAN_Aware Lookup*, and *Egress*.

Packet processing begins in the Ingress Filtering process. Each port has an associated packet forwarding state that can be one of four values (Disabled, Blocked, Learning, or Forwarding). The default state for all ports is Disabled. The host sets the packet forwarding state for each port.

In the packet ingress process (receive packet process), there is a forward state test for unicast destination addresses and a forward state test for multicast addresses. The multicast forward state test indicates the port states required for the receiving port in order for the multicast packet to be forwarded to the transmit port(s). A transmit port must be in the Forwarding state for the packet to be forwarded for transmission. The MCAST_FWD_STATE indicates the required port state for the receiving port as indicated in the preceding table. The unicast forward state test indicates the port state required for the receiving port in order to forward the unicast packet. The transmit port must be in the Forwarding state in order to forward the packet. The BLOCK and SECURE bits determine the unicast forward state test criteria. If both bits are set then the packet is forwarded if the receive port is in the Forwarding/Blocking/Learning state. If both bits are not set then the packet is forwarded if the receive port is in the Forwarding state. The transmit port must be in the Forwarding state regardless. The forward state test used in the ingress process is determined by the destination address packet type (multicast/unicast).

In general, packets received with errors are dropped by the address lookup engine without learning, updating, or touching the address. The error condition and the abort are indicated by the Ethernet port to the ALE. Packets with errors may be passed to the host (not aborted) by a Ethernet port port, if the port has the RX_CMF_EN, RX_CEF_EN, or RX_CSF_EN bit(s) set in the CPSW_PN_MAC_CONTROL_REG register. Error packets that are passed to the host by the Ethernet port are considered to be bypass packets by the ALE and are sent only to

the host. Error packets do not learn, update, or touch addresses regardless of whether they are aborted or sent to the host. Packets with long or short errors received by the host are dropped. Packets with errors received by the host are forwarded as normal.

The following control bits are in the CPSW_PN_MAC_CONTROL_REG register:

- [22] RX_CEF_EN - enables frames that are fragments, long, jabber, CRC, code, and alignment errors to be forwarded
- [23] RX_CSF_EN - enables short frames to be forwarded
- [24] RX_CMF_EN - enables MAC control frames to be forwarded.

13.2.1.4.6.1.16.1 Ingress Filtering Process

Condition and action
If ((ALE BYPASS) and (host port is not the receive port)) then use host portmask and go to Egress process
if (directed packet) then use directed port number and go to Egress process
If (Rx Iy_REG_Py_PORTSTATE is Disabled) then discard the packet
if ((ALE BYPASS or error packet) and (host port is not the receive port)) then use host portmask and go to Egress process
if (((BLOCK) and (unicast source address found)) or ((BLOCK) and (unicast destination address found))) then discard the packet
if ((ENABLE_RATE_LIMIT) and (rate limit exceeded) and (not BCAST_MCAST_CTL)) then if (((Multicast/Broadcast destination address found) and (not SUPER)) or (Multicast/Broadcast destination address not found)) then discard the packet
if ((not forward state test valid) and (destination address found)) then discard the packet to any port not meeting the requirements <ul style="list-style-type: none"> • Unicast destination addresses use the unicast forward state test and multicast destination addresses use the multicast forward state test.
if ((destination address not found) and ((not transmit port forwarding) or (not receive port forwarding))) then discard the packet to any ports not meeting the above requirements
if (source address found) and (secure) and (not block) and (receive port number != port_number)) then discard the packet
if ((not super) and (drop_untagged) and ((non-tagged packet) or ((priority tagged) and not(en_vid0_mode))) then discard the packet

<pre> If (VLAN_Unaware) CPSW_ALE_UVLAN_UNTAG = "000000" CPSW_ALE_UVLAN_URCAST = "111111" CPSW_ALE_UVLAN_URCAST = "111111" UVLAN_MEMBER_LIST = "111111" else if (VLAN not found) CPSW_ALE_UVLAN_UNTAG = CPSW_ALE_UVLAN_UNTAG CPSW_ALE_UVLAN_RMCAST = CPSW_ALE_UVLAN_RMCAST CPSW_ALE_UVLAN_RMCAST = CPSW_ALE_UVLAN_RMCAST CPSW_ALE_UVLAN_MEMBER = CPSW_ALE_UVLAN_MEMBER else CPSW_ALE_UVLAN_UNTAG = found CPSW_ALE_UVLAN_UNTAG CPSW_ALE_UVLAN_URCAST = found CPSW_ALE_UVLAN_URCAST CPSW_ALE_UVLAN_RMCAST = found CPSW_ALE_UVLAN_RMCAST UVLAN_MEMBER_LIST = found UVLAN_MEMBER_LIST if ((not SUPER) and (ly_REG_Py_VID_INGRESS_CHECK) and (Rx port is not VLAN member)) then discard the packet if ((ENABLE_AUTH_MODE) and (source address not found) and not(destination address found and (SUPER))) then discard the packet if (destination address equals source address) then discard the packet if (VLAN_AWARE) goto VLAN_Aware_Lookup process else goto VLAN_Unaware_Lookup process </pre>

13.2.1.4.6.1.16.2 VLAN_Aware Lookup Process

Condition and action
<pre> if ((unicast packet) and (destination address found with or without VLAN) and (not SUPER)) then portmask is the logical "AND" of the PORT_NUMBER and UVLAN_MEMBER_LIST less the host port and goto Egress process </pre>
<pre> if ((unicast packet) and (destination address found with or without VLAN) and (not SUPER)) then portmask is the logical "AND" of the PORT_NUMBER and the UVLAN_MEMBER_LIST and goto Egress process </pre>
<pre> if ((unicast packet) and (destination address found with or without VLAN) and (SUPER)) then portmask is the PORT_NUMBER and goto Egress process </pre>
<pre> if (Unicast packet) # destination address not found then portmask is VLAN member LIST less host port and goto Egress process </pre>
<pre> if ((Multicast packet) and (destination address found with or without VLAN) and (not SUPER)) then portmask is the logical "AND" of CPSW_ALE_UVLAN_URCAST and found destination address/VLAN portmask (PORT_MASK) and UVLAN_MEMBER_LIST and goto Egress process </pre>
<pre> if ((Multicast packet) and (destination address found with or without VLAN) and (SUPER)) then portmask is the PORT_MASK and goto Egress process </pre>

```

if (Multicast packet) # destination address not found
then portmask is the logical "AND" of CPSW_ALE_UVLAN_URCAST and UVLAN_MEMBER_LIST
then goto Egress process

if (Broadcast packet)
then use found UVLAN_MEMBER_LIST and goto Egress process

```

Note

The UVLAN_MEMBER_LIST, UVLAN_UNREG_MCAST_FLOOD_MASK, UVLAN_REG_MCAST_FLOOD_MASK and UVLAN_FORCE_UNTAGGED_EGRESS are set in the [Section 13.2.1.4.6.1.16.1 Ingress Filtering Process](#), based on VLAN_Unaware, Unknown_VLAN rules and VLAN table entries.

13.2.1.4.6.1.16.3 Egress Process

Condition and action
Clear Rx port from portmask (don't send packet to Rx port).
Clear disabled ports from portmask.
if ((ENABLE_OUI_DENY) and (OUI source address not found) and (not ALE BYPASS) and (not error packet) and ((not mcast destination address) and (SUPER))) then Clear host port from portmask
if ((not ENABLE_OUI_DENY) and (OUI source address found) and (not ALE BYPASS) and (not error packet) and not ((mcast destination address) and (SUPER))) then Clear host port from portmask
if ((ENABLE_RATE_LIMIT) and (BCAST_MCAST_CTL)) then if (not SUPER) and (rate limit exceeded on any tx port) then clear rate limited tx port from portmask If address not found then SUPER cannot be set.
If portmask is zero then discard packet
Send packet to portmask ports.

13.2.1.4.6.1.16.4 Learning/Updating/Touching Processes

The learning, updating, and touching processes are applied to each receive packet that is not aborted. The processes are concurrent with the packet forwarding process. In addition to the following, a packet must be received without error in order to learn/update/touch an address.

2.1.4.6.1.16.4.1 Learning Process

The learning process is applied to each receive packet that is not aborted. The learning process is a concurrent process with the packet forwarding process.

Condition and action
If (directed) then do not learn, update, or set touched else continue
If (not (Learning or Forwarding) or (ENABLE_AUTH_MODE) or (packet error) or (ly_REG_Py_NO_LEARN)) then do not learn address
if ((Non-tagged packet) and (ly_REG_Py_DROP_UN_TAGGED)) then do not learn address

if ((VLAN_AWARE) and (VLAN not found) and (unknown UVLAN_MEMBER_LIST = "000")) then do not learn address
if ((ly_REG_Py_VID_INGRESS_CHECK) and (Rx port is not VLAN member) and (VLAN found)) then do not learn address
if ((source address found) and (receive port_number != PORT_NUMBER) and (SECURE or BLOCK)) then do not update address else continue
if ((source address found) and (receive port number != PORT_NUMBER)) then update address else continue
if ((source address not found) and (VLAN_AWARE) and not (LEARN_NO_VLANID)) then learn address with VLAN
if ((source address not found) and ((not VLAN_AWARE) or (VLAN_AWARE and LEARN_NO_VLANID))) then learn address without VLAN

2.1.4.6.1.16.4.2 Updating Process

Condition and action
if (dlr_unicast) then do not update address
If (not(Learning or Forwarding) or (ENABLE_AUTH_MODE) or (packet error) or (ly_REG_Py_NO_SA_UPDATE)) then do not update address
if ((Non-tagged packet) and (ly_REG_Py_DROP_UN_TAGGED)) then do not update address
if ((VLAN_AWARE) and (VLAN not found) and (unknown UVLAN_MEMBER_LIST = "000")) then do not update address
if ((ly_REG_Py_VID_INGRESS_CHECK) and (Rx port is not VLAN member) and (VLAN found)) then do not update address
if ((source address found) and (receive port number != PORT_NUMBER) and (SECURE or BLOCK)) then do not update address
if ((source address found) and (receive port number != PORT_NUMBER)) then update address

2.1.4.6.1.16.4.3 Touching Process

if ((source address found) and (ageable) and (not touched)) then set touched

13.2.1.4.6.1.17 VLAN Aware Mode

The CPSW is in VLAN aware mode when the VLAN_AWARE bit is set in the CPSW_CONTROL_REG register.

In VLAN aware mode, transmitted packet data is changed depending on the packet type (PKT_TYPE), packet priority (PKT_PRI), and VLAN information.

The VLAN_LTYPE_SEL value is selected by the S_CN_SWITCH bit in the CPSW_CONTROL_REG register and is either the VLAN_LTYPE_INNER (8100h default) or VLAN_LTYPE_OUTER (88A8h default) value.

13.2.1.4.6.1.18 VLAN Unaware Mode

An egress port is operating in the VLAN unaware mode when the VLAN_AWARE bit in the CPSW_CONTROL_REG register is cleared to 0h. In VLAN unaware mode, transmit (egress) packets are not modified on egress.

13.2.1.4.6.2 Packet Priority Handling

Packets are received on two ports, one Ethernet port and one CPPI host port. Received packets have a received packet priority (0 to 7, with 7 being the highest priority).

The received packet priority is determined as follows:

1. If the first packet LTYPE = VLAN_LTYPE_SEL then the received packet priority is the packet priority (VLAN tagged and priority tagged packets).
2. Else if the first packet LTYPE = 0x0800 and byte 14 (following the LTYPE) is equal to 0x4X, and DSCP_IPV4_EN is set in CPSW_P0_CONTROL_REG or CPSW_PN_CONTROL_REG, then the received packet priority is the 6-bit TOS field in byte 15 (upper 6 bits) mapped through the port's DSCP priority mapping registers (IPv4 packet).
3. Else if the first packet LTYPE = 0x86DD and the most significant nibble of byte 14 (following the LTYPE) is equal to 0x6, and DSCP_IPV6_EN is set in CPSW_P0_CONTROL_REG or CPSW_PN_CONTROL_REG, then the received packet priority is the 6-bit priority (in the 6-bits following the upper nibble 0x6) mapped through the port's DSCP priority mapping registers (IPv6 packet).
4. Else the received packet priority is the source (ingress) port priority.

The received packet priority is mapped through the receive ports associated packet-priority-to-header-packet-priority-mapping register (CPSW_PN_RX_PRI_MAP_REG) to obtain the header packet priority. The header packet priority is the hardware switch priority. The header packet priority is also used as the actual transmit packet priority if the VLAN information is to be sent on egress.

The header packet priority is mapped at each destination FIFO through the CPSW_PN_TX_PRI_MAP_REG register (header priority to switch priority mapping register) to obtain the hardware switch priority (hardware queue 0 through 7).

13.2.1.4.6.2.1 Priority Mapping and Transmit VLAN Priority

There are three priorities that are used inside the Gigabit Ethernet Switch: **packet priority**, **header packet priority**, and **switch priority**. The **header packet priority** is used as the outgoing VLAN priority if the packet is egressing from the switch with a VLAN tag. The **switch priority** determines which of the 8 FIFO priority queues the packet uses during egress.

Figure 13-100 below, as well as the corresponding explanation that follows, explains each of the priorities, how they are determined, and how they are used. A number in parentheses in the figure indicates a process (Ethernet port ingress, host port egress, etc.). Each bullet in the text following the diagram explains one of the 5 processes pointed out in the figure.

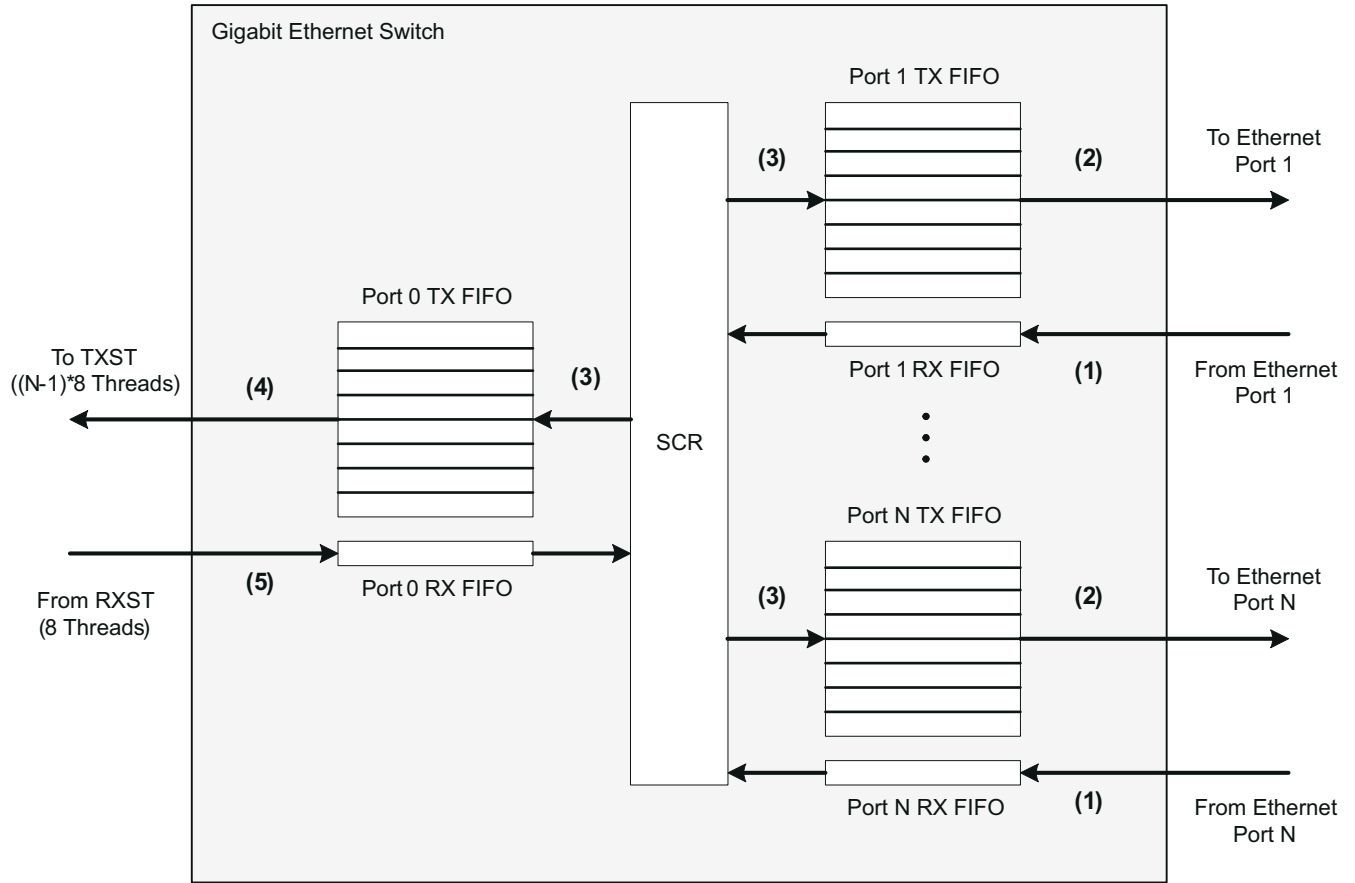

Figure 13-100. Gigabit Ethernet Switch Priority Mapping and Transmit VLAN Processing

ADVANCE INFORMATION

From [Figure 13-100](#) above:

- (1) is the ingress process that occurs at the external Ethernet ports
 - The incoming packet is assigned a **packet priority** based on either its VLAN priority, IPv4 or IPv6 DSCP value, or the ingress port's priority. This **packet priority** is then mapped to a **header packet priority** using the CPSW_PN_RX_PRI_MAP_REG register where N is the port where the packet entered the switch. This process is explained in further detail in [Section 13.2.1.4.6.2](#).
- (2) is the egress process that occurs at the external Ethernet ports
 - If the switch is in VLAN Aware mode then the VLAN header may be added, replaced, or removed during the egress process. If the VLAN header is to be added or replaced, the VLAN priority will come from the **header packet priority** that was determined in process (1) or (5). Transmit VLAN processing is the same for both the host port and the external Ethernet ports and is described in [Section 13.2.1.4.6.4.1](#).
- (3) is the process by which it is decided which priority TX queue to place the packet on in the Port N TX FIFO during egress
 - Each Port's TX FIFO has 8 queues that each correspond to a priority that is used when determining which packet will egress from the switch next at that port. The **header packet priority** (Ethernet port ingress, process (1)) or the receive packet thread (host port 0 ingress, process (5)) gets mapped through the CPSW_PN_RX_PRI_MAP_REG register (where N is the egress port number) to determine the **switch priority** of the packet. The **switch priority** determines which TX FIFO queue to place the packet in. The FIFO architecture is described in [Section 13.2.1.4.6.9.5](#). The header packet priority to switch priority mapping is discussed in [Section 13.2.1.4.6.2](#).
- (4) is the egress process that occurs at Host Port 0 toward the transmit streaming interface (TXST)
 - The TXST has 8 egress threads for each external Ethernet port (32 threads in a 5-port switch and 64 threads in a 9-port switch). The TX thread that is selected for a packet is determined by the Ethernet port of ingress and the **switch priority** of the packet that was determined in process (3).
 - If the switch is in VLAN Aware mode then the VLAN header may be added, replaced, or removed during the egress process. If the VLAN header is to be added or replaced, the VLAN priority will come from the **header packet priority** that was determined in process (1). Transmit VLAN processing is the same for both the host port and the external Ethernet ports and is described in [Section 13.2.1.4.6.4.1](#).
- (5) is the ingress process that occurs at Host Port 0
 - The incoming packet is assigned a **packet priority** based on either its VLAN priority, IPv4 or IPv6 DSCP value, or the host port's priority. This packet priority is then mapped to a **header packet priority** using the CPSW_PN_RX_PRI_MAP_REG register.
 - Host port 0 also has a received packet thread. The receive packet thread is based on either the packet's VLAN priority, IPv4 or IPv6 DSCP value, or the streaming interface (RXST) thread that the packet entered host port 0 on.

13.2.1.4.6.3 CPPI Port Ingress

Packets received on the CPPI host port have a received packet priority (0 to 7 with 7 being the highest priority).

The received packet priority is determined as follows:

1. If the first packet LTYPE = VLAN_LTYPE_SEL then the received packet priority is the packet priority (VLAN tagged and priority tagged packets).
2. Else if the first packet LTYPE = 0x0800 and byte 14 (following the LTYPE) is equal to 0x4X, and DSCP_IPV4_EN is set in CPSW_P0_CONTROL_REG or CPSW_PN_CONTROL_REG register, then the received packet priority is the 6-bit TOS field in byte 15 (upper 6 bits) mapped through the port's DSCP priority mapping registers (IPv4 packet).
3. Else if the first packet LTYPE = 0x86DD and the most significant nibble of byte 14 (following the LTYPE) is equal to 0x6, and DSCP_IPV6_EN is set in CPSW_P0_CONTROL_REG or CPSW_PN_CONTROL_REG register, then the received packet priority is the 6-bit priority (in the 6-bits following the upper nibble 0x6) mapped through the port's DSCP priority mapping registers (IPv6 packet).
4. Else the received packet priority is the source (ingress) port priority

The CPPI Port (port 0) also has a received packet thread. The received packet thread is determined exactly as the received packet priority except for untagged packets. For untagged packets, the received packet thread is

the packet streaming interface thread that the packet was received on (instead of the port VLAN priority or DSCP priority). The received packet thread is the hardware switch priority. The received packet thread only determines which hardware switch priority the packet should be sent to, the egress VLAN rules are identical to packets that were received on Ethernet ports (as determined by the header packet priority).

For CPPI ingress packets, the destination port hardware switch priority is the below selected value remapped through CPSW_PN_RX_PRI_MAP_REG:

1. If the ingress packet is priority tagged or vlan tagged:
 - If RX_REMAP_VLAN in CPSW_P0_CONTROL_REG register is clear then the the destination hardware switch priority is the CPPI receive thread number.
 - If RX_REMAP_VLAN in CPSW_P0_CONTROL_REG register is set then the the destination hardware switch priority is the packet priority value. Port transmit remapping (CPSW_PN_TX_PRI_MAP_REG should remain the default value) is not compatible with this bit being set, but remapping can be configured on port 0 receive.
2. Else if the ingress packet has the first packet LTYPE = 0x0800 and byte 14 (following the LTYPE) is equal to 0x4X, and DSCP_IPV4_EN is set in CPSW_P0_CONTROL_REG register:
 - If RX_REMAP_DSCP_V4 bit in CPSW_P0_CONTROL_REG register is clear then the destination hardware switch priority is the CPPI receive thread number.
 - If RX_REMAP_DSCP_V4 bit in CPSW_P0_CONTROL_REG register is set then the destination hardware switch priority is the 6-bit TOS field in byte 15 (upper 6-bits) mapped through the port's DSCP priority mapping registers (IPV4 packet). Port 1 transmit remapping (CPSW_PN_TX_PRI_MAP_REG should remain the default value) is not compatible with this bit being set, but remapping can be configured on port 0 receive.
3. Else if the ingress packet has the first packet LTYPE = 0x86DD and the most significant nibble of byte 14 (following the LTYPE) is equal to 0x6, and DSCP_IPV6_EN is set in P0_CONTROL_REG register:
 - If RX_REMAP_DSCP_V6 bit in CPSW_P0_CONTROL_REG register is clear then the destination hardware switch priority is the CPPI receive thread number.
 - If RX_REMAP_DSCP_V6 bit in CPSW_P0_CONTROL_REG register is set then the destination hardware switch priority is the 6-bit priority (in the 6-bits following the upper nibble 0x6) mapped through the port's DSCP priority mapping registers (IPV6 packet). Port 1 transmit remapping (CPSW_PN_TX_PRI_MAP_REG should remain the default value) is not compatible with this bit being set, but remapping can be configured on port 0 receive.
4. Else the ingress packet is non-tagged and the destination hardware switch priority is the CPPI receive thread number.

13.2.1.4.6.4 Packet CRC Handling

The P0_TX_CRC_REMOVE bit in the CPSW_CONTROL_REG register determines if host port egress packets have CRC included or not. If P0_TX_CRC_REMOVE is set to 1h then all packets that are transmitted from port 0 do not contain CRC. If P0_TX_CRC_REMOVE bit is cleared to 0h then all packets that are transmitted from port 0 contain CRC. The CRC type, if present, is determined by the CRC_TYPE bit in the CPSW_PN_MAC_CONTROL_REG register. If the CRC_TYPE bit is cleared to 0h then the CRC present in each packet after host port egress is Ethernet CRC. If the CRC_TYPE bit is set to 1h then the CRC present in each packet after host port egress is Castagnoli CRC.

Note

The CRC type present in the packet after host port egress is determined solely by the CRC_TYPE bit in the CPSW_PN_MAC_CONTROL_REG register regardless of the CRC type present in the packet during Ethernet port ingress.

13.2.1.4.6.4.1 Transmit VLAN Processing

Transmit packets are NOT modified during switch egress when the VLAN_AWARE bit in the CPSW_CONTROL_REG register is cleared to 0h. This means that the switch is not in VLAN-aware mode.

The next three sections cover transmit processing when the switch is in VLAN-aware mode for different packet types. The Gigabit Ethernet switch is in VLAN-aware mode when the VLAN_AWARE bit is set in the CPSW_CONTROL_REG register. While in VLAN-aware mode, VLAN is added, removed, or replaced according to the type of packet as well as the CPSW_ALE_UVLAN_UNTAG[1-0] UVLAN_FORCE_UNTAGGED_EGRESS bit in the packet header as explained below.

13.2.1.4.6.4.1.1 Untagged Packets (No VLAN or Priority Tag Header)

Untagged packets are all packets that are not a VLAN packet or a priority tagged packet. According to the CPSW_ALE_UVLAN_UNTAG[1-0] UVLAN_FORCE_UNTAGGED_EGRESS bit in the packet header the packet may exit the switch with a VLAN tag inserted or the packet may leave the switch unchanged. The two cases are discussed below.

- Insert VLAN Case:

Untagged input packets have the header packet VLAN inserted when the CPSW_ALE_UVLAN_UNTAG[1-0] UVLAN_FORCE_UNTAGGED_EGRESS bit in the transmit packet header is de-asserted. For untagged packets, the VLAN EtherType = 0x8100 is inserted after the source address followed by the two byte header packet VLAN. The header packet VLAN is composed of the header packet priority along with the PORT_CFI and PORT_VID values from the CPSW_PN_PORT_VLAN_REG register (where N is the port that the untagged packet entered the switch) through. The packet length/type field is output four bytes later than it is input and is not removed or replaced. If the CRC is present in the packet data (PASS_CRC is asserted), then the packet CRC is replaced with a hardware generated CRC.

- No Change Case:

Untagged input packets are output unchanged when the CPSW_ALE_UVLAN_UNTAG[1-0] UVLAN_FORCE_UNTAGGED_EGRESS transmit packet header bit is asserted.

13.2.1.4.6.4.1.2 Priority Tagged Packets (VLAN VID == 0 && EN_VID0_MODE == 0h)

Priority tagged packets are packets that contain a VLAN header with VID = 0. According to the CPSW_ALE_UVLAN_UNTAG[1-0] UVLAN_FORCE_UNTAGGED_EGRESS bit in the packet header, priority tagged packets may exit the switch with their VLAN ID and priority replaced or they may have their priority tag completely removed. The two cases are discussed below.

Note

In order for a priority tagged packet to fall into this category the ENABLE_VID0_MODE bit in the CPSW_ALE_CONTROL register must also be set to 0h. If the ENABLE_VID0_MODE bit in the CPSW_ALE_CONTROL register is set to 1h, then packets with a VLAN VID of 0 will fall into the VLAN Tagged Packets category in [Section 13.2.1.4.6.4.1.3](#) below.

- Replace Priority and VLAN ID Case:

Priority tagged input packets have the packet VLAN ID and the packet priority replaced with the header packet VLAN ID and the header packet priority when the transmit packet header CPSW_FORCE_UNTAGGED_EGRESS_REG[1-0] MASK bit is de-asserted. The header packet VLAN ID comes from the PORT_VID bits in the CPSW_PN_PORT_VLAN_REG register (where N is the port where the packet entered the switch). The header packet priority is based on the packet priority to header packet priority mapping in the CPSW_PN_RX_PRI_MAP_REG register (where N is the port where the packet entered the switch).

- Remove VLAN Header Case:

Priority tagged input packets have the 4-byte packet VLAN information removed when the transmit packet header CPSW_ALE_UVLAN_UNTAG[1-0] UVLAN_FORCE_UNTAGGED_EGRESS bit is asserted. The 0x8100 EtherType is removed as is the two byte packet VLAN. Input 64-67 byte priority tagged packets go out with the VLAN removed and padded to 64-bytes if the PASS_CRC input bit is asserted. The input CRC bytes are used as the pad data. Input 64-byte priority-tagged packets use all four input CRC bytes as pad, input 65-byte priority-tagged packets use three of the input CRC bytes as pad, and so on. No

pad is performed if the PASS_CRC input bit is not asserted - input 64-67 byte (on the wire) priority-tagged packets go out as 60-63 byte packets. The output CRC is replaced with a generated CRC when the VLAN is removed.

13.2.1.4.6.4.1.3 VLAN Tagged Packets (VLAN VID != 0 || (EN_VID0_MODE == 1h && VLAN VID == 0))

VLAN tagged packets are packets that contain a VLAN header specifying the VLAN the packet belongs to (VID), the packet priority (PRI), and the drop eligibility indicator (CFI). According to the CPSW_ALE_UVLAN_UNTAG[1-0] UVLAN_FORCE_UNTAGGED_EGRESS bit in the packet header, VLAN tagged packets may exit the switch with their VLAN priority replaced or they may have their VLAN header completely removed. The two cases are discussed below.

- **Replace Priority Case:**

VLAN tagged input packets are output with the packet priority replaced with the header packet priority when the transmit packet header CPSW_ALE_UVLAN_UNTAG[1-0] UVLAN_FORCE_UNTAGGED_EGRESS bit is deasserted. The header packet priority is based on the packet priority to header packet priority mapping in the CPSW_PN_RX_PRI_MAP_REG register (where N is the port where the packet entered the switch). If the CRC is present in the packet data (PASS_CRC is asserted), then the packet CRC is replaced with a generated CRC.

- **Remove VLAN Header Case:**

VLAN tagged input packets have the 4-byte packet VLAN information removed when the transmit packet header CPSW_ALE_UVLAN_UNTAG[1-0] UVLAN_FORCE_UNTAGGED_EGRESS bit is asserted. The 0x8100 EtherType is removed as is the two byte packet VLAN. Input 64-67 byte priority tagged packets go out with the VLAN removed and padded to 64-bytes if the PASS_CRC input bit is asserted. The input CRC bytes are used as the pad data. Input 64-byte priority tagged packets use all four input CRC bytes as pad, input 65-byte priority tagged packets use three of the input CRC bytes as pad, and so on. No pad is performed if the PASS_CRC input bit is not asserted - input 64-67 byte (on the wire) priority tagged packets go out as 60-63 byte packets. The output CRC is replaced with a generated CRC when the VLAN is removed.

13.2.1.4.6.4.2 Ethernet Port Ingress Packet CRC

All Ethernet ports check the ingress packet CRC in all modes/speeds. The receive port can check either Ethernet CRC or Castagnoli CRC as determined by the CRC_TYPE bit in the CPSW_PN_MAC_CONTROL_REG register.

13.2.1.4.6.4.3 Ethernet Port Egress Packet CRC

Ethernet ports transmit each egress packet with the CRC selected by the CRC_TYPE bit in the CPSW_PN_MAC_CONTROL_REG register, regardless of the type of CRC that the packet had on ingress to the switch. At the egress port after passing through the switch, the packet CRC is checked for correctness and if the CRC is correct then the packet is output with the generated selected output CRC. If the packet CRC is incorrect, due either to a bit flip in a memory or an error CRC passed in on host ingress, then the generated egress CRC type is used with at least a single byte of the CRC inverted to indicate the error. If the packet length including CRC is divisible by 4 then all 4 CRC bytes will be inverted on error. If there are three bytes remainder after dividing the packet length by 4 then three bytes will be inverted (and so on down to one byte remainder).

13.2.1.4.6.4.4 CPPI Port Ingress Packet CRC

CPPI port ingress packets can be passed in with or without a CRC. The host port is Ethernet CRC only. CPPI ingress packets are not checked for CRC correctness on CPPI ingress, however they are checked for correctness on Ethernet egress and are output with a CRC error if they came in with a CRC error. If a CPPI ingress packet does not have the INFO0 PASSED_CRC bit set then a CRC will be generated for the packet on CPPI ingress. If the PASSED_CRC bit is set then the packet is received and forwarded unchanged. The CRC type is input in the INFO0 word CRC_TYPE bit and must be Ethernet CRC.

13.2.1.4.6.4.5 CPPI Port Egress Packet CRC

The P0_TX_CRC_REMOVE bit in the CPSW_CONTROL_REG register determines if CPPI egress packet have an Ethernet CRC included or not.

13.2.1.4.6.5 FIFO Memory Control

Each of the two CPSW_2G ports has an identical associated FIFO. Each FIFO contains a single logical receive queue and eight logical transmit queues (priority 0 through 7 with 7 the highest priority). Each FIFO memory contains 20,480 bytes (20k) total organized as 2560 by 64-bit words contained in a single memory instance. The FIFO memory is used for the associated port transmit and receive queues. The TX_MAX_BLKs field in the FIFOs associated CPSW_PN_MAX_BLKs_REG register determines the maximum number of 1k FIFO memory blocks to be allocated to the eight logical transmit queues (transmit total). The RX_MAX_BLKs field in the FIFO's associated CPSW_PN_MAX_BLKs_REG register determines the maximum number of 1k memory blocks to be allocated to the logical receive queue. The TX_MAX_BLKs value plus the RX_MAX_BLKs value must sum to 20 (the total number of blocks in the FIFO). If the sum were less than 20, then some memory blocks would be unused. The default is 17 (decimal) transmit blocks and three receive blocks. The FIFOs follow the naming convention of the Ethernet ports. Host Port is Port0 and External Ports is Port1.

Each transmit FIFO contains a configurable number of blocks (20 max) that are either 1k or 4k byte blocks that can be allocated to any priority.

13.2.1.4.6.6 FIFO Transmit Queue Control

There are eight transmit queues in the Ethernet port transmit FIFO. Software has some flexibility in determining how packets are loaded into the queues and on how packet priorities are selected for transmission (how packets are removed and transmitted from queues).

13.2.1.4.6.6.1 CPPI Port Receive Rate Limiting

Port 0 receive operations can be configured to rate limit the host ingress data for each receive thread (priority). CPPI Receive has 8 threads for QOS. There is a committed information rate (CPSW_P0_PRI_CIR_REG_y, where y = 0 to 7) and an excess information rate for each thread (CPSW_P0_PRI_EIR_REG_y, where y = 0 to 7). Rate limiting is enabled for a thread when the committed information rate for the thread is non-zero. The excess information rate for a priority is enabled when the excess information rate for the priority is non-zero. The committed information rate must be non-zero if the excess information rate is configured to be non-zero. That is, there must be a configured non-zero committed information rate for there to be a configured non-zero excess information rate. Bulk traffic on other non-rate limited priorities does not impact the committed information traffic on a priority. However, bulk traffic on other non-rate limited threads does impact the excess information rates. No bulk thread will be enabled to send unless there are CPSW_PN_PRI_CTL_REG[15-12] TX_HOST_BLKs_REM number of unused blocks remaining in each of the Ethernet port transmit FIFOs. The "blocks remaining check" ensures that bulk traffic from the host will not block rate-limited traffic from the host. Rate limited channels must be the highest priority channels. For example, if two rate limited channels are required then threads 7 and 6 should be configured for committed information (and excess information if desired). When any channels are configured to be rate-limited, the priority type must be fixed for receive. Round-robin priority type is not allowed when rate-limiting is configured for any thread. The configured transfer rate includes the inter-packet gap (12 bytes) and the preamble (8 bytes). The rate in Mbits/second that each priority is configured to receive is controlled by the below equation. If the configured excess information rate is zero, then only the committed information rate is transferred:

Priority Transfer rate [Mbit/s] = (((Frequency in MHZ) * CPSW_P0_PRI_CIR_REG_y) / 32768) + (((Frequency in MHZ) * CPSW_P0_PRI_EIR_REG_y) / 32768))

Where the *frequency* is the CPPI_ICLK frequency (in MHz) and priority 0 to 7.

For example, 10Mbps on priority 7 would give the below:

10Mbps = ~ ((350 * 936) / 32768), at 350Mhz and CPSW_P0_PRI_CIR_REG_y[27-0] PRI_CIR value = 936 (no excess information rate)

13.2.1.4.6.6.2 Ethernet Port Transmit Rate Limiting

Ethernet port transmit operations can be configured to rate limit egress data for each egress priority. There is a committed information rate (CPSW_P0_PRI_CIR_REG_y, where y = 0 to 7) and an excess information rate for each priority (CPSW_P0_PRI_EIR_REG_y, where y = 0 to 7). Rate limiting is enabled for a priority when the committed information rate for the priority is non-zero. The excess information rate for a priority is enabled when the excess information rate for the priority is non-zero. The committed information rate must be non-zero if the excess information rate is configured to be non-zero. That is, there must be a configured non-zero committed information rate for there to be a configured non-zero excess information rate. Bulk traffic on other non-rate limited priorities does not impact the committed information traffic on a priority. However, bulk traffic on other non-rate limited threads does impact the excess information rates. Rate limited channels must be the highest priority channels. For example, if two rate limited channels are required then priorities 7 and 6 should be configured for committed information (and excess information if desired). The configured transfer rate includes the inter-packet gap (12 bytes) and the preamble (8 bytes). The rate in Mbits/second that each priority is configured to send is controlled by the below equation. If the excess information rate is disabled then the committed information rate only is transferred:

$$\text{Priority Transfer rate [Mbit/s]} = (((\text{Frequency in MHz}) * \text{CPSW_P0_PRI_CIR_REG_y}) / 32768) + (((\text{Frequency in MHz}) * \text{CPSW_P0_PRI_EIR_REG_y}) / 32768)$$

Where the *frequency* is the CPPI_ICLK frequency (in MHz) and priority 0 to 7.

13.2.1.4.6.7 Enhanced Scheduled Traffic (EST – P802.1Qbv/D2.2)

13.2.1.4.6.7.1 Enhanced Scheduled Traffic Overview

- When enabled and configured, EST allows express queue traffic to be scheduled (placed) on the wire at specific repeatable time intervals.
- EST operates on a repeating time interval generated by the CPTS EST function generator. For example, a 125us repeating time interval can be configured.
- Each Ethernet port has 128 EST fetch commands maximum in the global EST fetch RAM.
- Each 22-bit fetch command consists of a 14-bit fetch count (14 MSB's) and an 8-bit priority fetch allow (8 LSB's) that will be applied for the fetch count time in wireside clocks.
- The configured port fetch commands are executed in sequence, beginning at port address zero each time through the time interval beginning at cycle start.
- EST allows non-scheduled express and preempt queue traffic to be cleared from the wire to ensure that the scheduled traffic is transmitted at the proper time (zero allow).
- EST can be used with or without preemption. The CPSW_PN_IET_CONTROL_REG[23-16] MAC_PREMPT value determines whether the priority is enabled on the express or preempt queue. Whether a priority is on the express or preempt queue only effects the wire clear time from an EST operation perspective.
- Software should not move priorities to the preempt queue unless preemption is configured, enabled, and verified allowing preemption to occur.
- Express packet time stamp events can be enabled to assist software in configuring and timing EST operations.

13.2.1.4.6.7.2 Enhanced Scheduled Traffic Fetch RAM

- The EST fetch RAM is read/writable in the CPSW configuration address space.
- The Ethernet transmit port has 128 locations in the global EST fetch RAM.
 - Ethernet port 1 has EST fetch RAM addresses 0x000-0x07F.
- **One buffer operation:** When CPSW_PN_EST_CONTROL_REG[0] EST_ONEBUF is set to 1h, the 128 port locations operate as one buffer. The EST_BUFACT bit in CPSW_PN_FIFO_STATUS_REG register is the upper address bit of the port's fetch RAM address indicating whether operation is currently in the upper or lower 64 locations of the port's fetch RAM.
- **Two buffer operation:** When CPSW_PN_EST_CONTROL_REG[0] EST_ONEBUF is cleared there are two 64-location buffers with CPSW_PN_EST_CONTROL_REG[1] EST_BUFSEL selecting the buffer to be used. When the buffer is switched by changing the CPSW_PN_EST_CONTROL_REG[1] EST_BUFSEL value, the actual switch occurs on cycle start. The actual buffer being used is indicated by the EST_BUFACT bit in

CPSW_PN_FIFO_STATUS_REG. Software should avoid writing the switched out buffer fetch RAM locations until it detects that the actual switch has occurred.

- The first address location in the port's fetch RAM space (location zero) is read at the beginning of each EST time interval (cycle start). Addresses are then read in ascending order for the duration of the interval. The port address zero is then read again at the beginning of the next cycle repeating the time interval packet operations.

13.2.1.4.6.7.3 Enhanced Scheduled Traffic Time Interval

- Each Ethernet port has an Enhanced Scheduled Traffic Function (ESTF) generator in the CPTS submodule.
- The EST function generator generates the EST time interval as a configured number of CPTS reference clocks (CPTS_RFT_CLK).
- The EST function generator rising edge is the cycle start time and the cycle repeats (cycle start occurs) after every time interval.
- The first fetch allowed value is at the port base address zero in the EST fetch RAM and is actually applied 16 wireside clocks after cycle start. The 16 clock cycle delay allows the first fetch value time to be fetched from the EST fetch RAM (prefetch time at cycle start).
- Each successive fetch allow is applied for the associated fetch count thereafter. The minimum non-zero fetch count is 16. The minimum value of 16 guarantees that the next fetch value has time to be fetched before the current fetch count is over. There are 64 maximum fetch values when CPSW_PN_EST_CONTROL_REG[0] EST_ONEBUF = 0h, and 128 maximum fetch values when CPSW_PN_EST_CONTROL_REG[0] EST_ONEBUF = 1h.
- The next cycle start then causes the fetch to once again start at the port address zero.

13.2.1.4.6.7.4 Enhanced Scheduled Traffic Fetch Values

- The 22-bit fetch value is made up of the 14-bit fetch count and the 8-bit fetch allow.
- The fetch time indicates the number of wireside clocks that the fetch allow will be active.
- The fetch count is in Ethernet wireside clocks which is bytes in Gigabit mode (CPSW_PN_MAC_CONTROL_REG[7] GIG = 1h) and nibbles in 10/100Mbps mode.
- When a fetch allow bit is set, the corresponding priority is enabled to begin packet transmission on an allowed priority subject to rate limiting. The actual packet transmission on the wire may carry over into the next fetch count and is the reason for the wire clear time in the fetch zero allow.
- When a fetch allow bit is cleared, the corresponding priority is not enabled to transmit for the fetch count time.
- A non-zero fetch allow value with a non-zero fetch count causes the fetch allow value to be applied for the fetch count number of wireside clocks.
- A zero fetch count causes the associated fetch allow to be held for the duration of the cycle (until the next cycle start).
- A zero fetch allow with a non-zero fetch count is intended to clear the wire for a scheduled (timed) express packet in the next fetch. A zero fetch allow indicates that no packet can be started for transmission for the associated fetch count. The associated fetch count must be sufficient to guarantee that the wire is cleared given that a packet on an allowed priority in the previous fetch could have been started on the previous clock and that there is hardware latency in the clear time. The timed packet should be sent on a priority that is enabled in the next fetch but disabled in the current zero allow fetch. The fetch allow previous to a zero allow should have only preempt priorities enabled or only express priorities enabled but not both.
- The number of clocks required to clear the wire varies depending Ethernet wire speed and on whether express or preempt priorities were allowed in the previous fetch command.

13.2.1.4.6.7.5 Enhanced Scheduled Traffic Packet Fill

Packet fill can be enabled (CPSW_PN_EST_CONTROL_REG[8] EST_FILL_EN = 1h) to occur in the fetch count time associated with a fetched zero allow. The intention with fill is that a smaller packet on a non-timed priority might be able to be inserted on the wire during the wire clear time which would increase wire utilization. Fill is intended to be used with either only express priorities in the previous non-zero fetched allow, or only preempt priorities in the previous non-zero fetched allow but not both. Fill must be configured to ensure that any fill packet does not conflict with the timed express packet allowed in the next fetch.

• Express fill:

1. CPSW_PN_EST_CONTROL_REG[8] EST_FILL_EN is set and

2. A fetch contains a non-zero fetch count with a zero fetch allow, and
 3. The previous allow contained only express priorities.
 4. The fetch count loaded should be at least TBD clocks and the CPSW_PN_EST_CONTROL_REG[25-16] EST_FILL_MARGIN should be at least TBD clocks in Gigabit mode to ensure that the wire is cleared for the timed express packet allowed in the next fetch.
 5. The fetch count loaded should be at least TBD clocks and the CPSW_PN_EST_CONTROL_REG[25-16] EST_FILL_MARGIN should be at least TBD clocks in 10/100Mbps mode to ensure that the wire is cleared for the timed express packet allowed in the next fetch.
- **Prempt fill:**
 1. CPSW_PN_EST_CONTROL_REG[8] EST_FILL_EN is set and
 2. A fetch contains a non-zero fetch count with a zero fetch allow, and
 3. The previous allow contained only preempt priorities
 4. The fetch count loaded should be at least TBD clocks in Gigabit mode to ensure that the wire is cleared for the timed express packet allowed in the next fetch.
 5. The fetch count loaded should be at least TBD clocks in 10/100Mbps mode to ensure that the wire is cleared for the timed express packet allowed in the next fetch.
 - **Express non-fill:**
 1. CPSW_PN_EST_CONTROL_REG[8] EST_FILL_EN is clear and
 2. The previous allow contained only express priorities.
 3. The fetch count loaded should be at least TBD clocks in Gigabit mode to ensure that the wire is cleared for the timed express packet allowed in the next fetch.
 4. The fetch count loaded should be at least TBD clocks in 10/100Mbps mode to ensure that the wire is cleared for the timed express packet allowed in the next fetch.
 - **Prempt non-fill:**
 1. CPSW_PN_EST_CONTROL_REG[8] EST_FILL_EN is clear and
 2. The previous allow contained only preempt priorities.
 3. The fetch count loaded should be at least TBD clocks in Gigabit mode to ensure that the wire is cleared for the timed express packet allowed in the next fetch.
 4. The fetch count loaded should be at least TBD clocks in 10/100Mbps mode to ensure that the wire is cleared for the timed express packet allowed in the next fetch.

13.2.1.4.6.7.6 Enhanced Scheduled Traffic Time Stamp

The EST can be configured to generate CPTS timestamp events for selected express traffic. The EST timestamp events use the CPTS host event type (CPSW_CPTS_EVENT_1_REG[23-20] EVENT_TYPE = 7 decimal). The EST timestamps will not override host sent timestamps for packets that were sent from the host with an enabled host timestamp.

- EST Events (host events) contain the below information:
 - Time Stamp of the selected express packet.
 - The event CPSW_CPTS_EVENT_1_REG[28-24] PORT_NUMBER indicates the transmit port number.
 - The event CPSW_CPTS_EVENT_1_REG[23-20] EVENT_TYPE is decimal 7 (host event).
 - The event CPSW_CPTS_EVENT_1_REG[23-20] MESSAGE_TYPE indicates the packet transmit hardware switch priority.
 - The event CPSW_CPTS_EVENT_1_REG[15-0] SEQUENCE_ID upper nibble indicates the packet receive port number.
 - The event CPSW_CPTS_EVENT_1_REG[15-0] SEQUENCE_ID lower byte indicates the sequence number of the express packet in numerical order. The first event is event one, the second is event two and so on. The sequence ID rolls over to zero after 0xFF (8-bits).
 - The event domain is the value from the CPSW_EST_TS_DOMAIN_REG[7-0] EST_TS_DOMAIN register.
- When CPSW_PN_EST_CONTROL_REG[2] EST_TS_EN is set, timestamp events will be generated on selected express traffic.
- When CPSW_PN_EST_CONTROL_REG[3] EST_TS_FIRST is also set, events will be generated only on the first express packet in each time interval. If CPSW_PN_EST_CONTROL_REG[4] EST_TS_ONEPRI is also set then the event will only be on the first CPSW_PN_EST_CONTROL_REG[7-5] EST_TS_PRI express

packet in the time interval. If CPSW_PN_EST_CONTROL_REG[4] EST_TS_ONEPRI is clear then the event will be generated on the first express packet in the time interval on any priority.

- When CPSW_PN_EST_CONTROL_REG[3] EST_TS_FIRST is clear, events will be generated on every express packet. If CPSW_PN_EST_CONTROL_REG[4] EST_TS_ONEPRI is set then the event will be generated on every CPSW_PN_EST_CONTROL_REG[7-5] EST_TS_PRI express packet. If CPSW_PN_EST_CONTROL_REG[4] EST_TS_ONEPRI is clear then event will be generated on every express packet on any priority.

13.2.1.4.6.7.7 Enhanced Scheduled Traffic Packets Per Priority

The number of packets allowed in a transmit FIFO priority can be selected by writing a non-zero value to CPSW_P0_RX_PKTS_PRI_REG register (packet priority 0 to 7). Then port 0 receive gap should then be enabled by setting the corresponding priority through CPSW_P0_RX_GAP_REG[7-0] RX_GAP_EN bit field. The receive gap allows a packet to land in the transmit FIFO before another packet is allowed in which guarantees that only the selected number (max) of packets is allowed in on the specified priority. If the receive gap is not enabled, then there might be one or two more packets allowed in on the priority/thread than the packets per priority value has selected (through CPSW_P0_RX_PKTS_PRI_REG register).

13.2.1.4.6.8 Audio Video Bridging

Audio Video Bridging is an ongoing project of IEEE 802.1 concerned with enabling low-latency streaming of time-sensitive audiovisual data over networks. Devices are designated as talkers (transmitters), bridges, or listeners (receivers). It is suggested that the maximum latency could be 2 ms over 7 hops for Class A devices and 20 ms over 7 hops for Class B devices. A hop is essentially a single local area network stage in the journey of a packet. Every time a bridge is encountered between one network section and another a hop is involved. One of the performance goals is that AVB streams will not use more than 75 percent of a link's bandwidth, leaving the remaining capacity for non-AVB streams.

The goal of developing AVB is simply--extend Ethernet's data-networking capabilities to the realm of reliable real-time audio/video networking.

An "Audio Video Bridging" network is one that implements a set of protocols being developed by the IEEE 802.1 Audio/Video Bridging Task Group. There are four primary differences between the proposed Audio Video Bridging architecture and existing 802 architectures (from now on the term "AVB" will be used instead of "Audio Video Bridging"):

1. Precise synchronization - IEEE 802.1AS: "*Timing and Synchronization for Time-Sensitive Applications in Bridged Local Area Networks*". "a.k.a Precision Time Protocol (PTP).
2. Traffic shaping for media streams - IEEE 802.1Qav: "*Virtual Bridged Local Area Networks: Forwarding and Queuing for Time-Sensitive Streams*."
3. Admission controls - IEEE 802.1Qat: "*Virtual Bridged Local Area Networks - Amendment 9: Stream Reservation Protocol (SRP)*."
4. Identification of non-participating devices - IEEE 802.1BA: "Audio/Video Bridging (AVB) Systems"

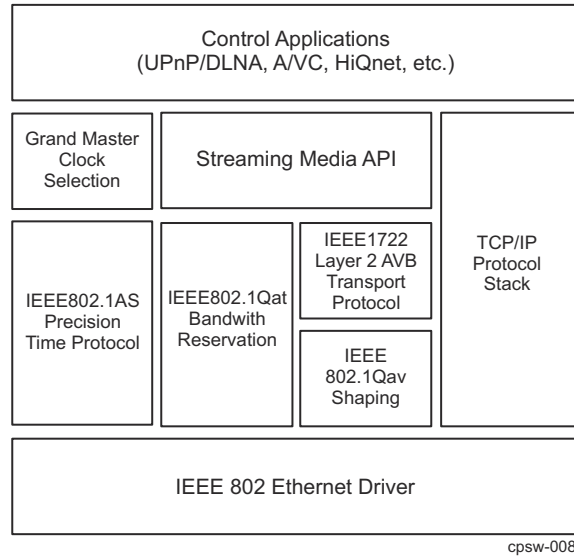

Figure 13-101. The Network Static with AVB

The following sections describe the media transport protocols that work within the AVB framework.

13.2.1.4.6.8.1 IEEE 802.1AS: Timing and Synchronization for Time-Sensitive Applications in Bridged Local Area Networks (Precision Time Protocol (PTP))

The protocol defined by 802.1AS automatically selects a device to be the master clock, and then distributes this clock throughout the bridged LAN / IP subnet to all other network devices using link-specific transmit/receive time-stamping. However, we only use a two-step solution only on transmit. That is, we do not modify a packet with the timestamp on the way out. The timestamp packet is sent out and then a separate message with the timestamp is sent by the host afterward. Receive can be one or two step.

Note

The 802.1AS-distributed clock is not used as a media clock. Rather, the shared 802.1AS clock reference is used to regenerate the media clock at the listener/renderer. Such a reference removes the need to force the latency of the network to be constant, or compute long running averages in order to estimate the actual media rate of the transmitter in the presence of substantial network jitter. IEEE 802.1AS is based on the ratified IEEE 1588 standard.

Based on IEEE 1588:2002, PTP devices exchange standard Ethernet messages that synchronize network nodes to a common time reference by defining clock master selection and negotiation algorithms, link delay measurement and compensation, and clock rate matching and adjustment mechanisms.

Designed as a simplified profile of IEEE 1588, a primary difference between 1588 and IEEE 802.1AS is that PTP is a layer 2-in other words, a non-IP routable protocol. Like IEEE 1588, PTP defines an automatic method for negotiating the network clock master, the Best Master Clock Algorithm (BMCA). PTP nodes can be assigned one of eight priority levels, presumably based on clock quality. BMCA defines the underlying negotiation and signaling mechanism whose purpose is to identify the AVB LAN Grandmaster. Once a Grandmaster has been selected, synchronization automatically begins.

At the core of 802.1AS synchronization is time-stamping. In short, during PTP message ingress/egress from the 802.1AS-capable MAC, the PTP Ether type triggers the sampling of the value of a local real-time counter (RTC). Slave nodes compare the value of their RTC against the PTP Grandmaster and, by use of link delay measurement and compensation techniques, match their RTC value to the time of the AVB LAN PTP domain. After network time throughout the AVB LAN has converged, periodic SYNC and FOLLOW_UP messages provide the information that enables the PTP rate matching adjustment algorithms. The result is all PTP nodes are then synchronized to the same "Wall Clock" time. PTP assures 1-µs accuracy over seven network hops.

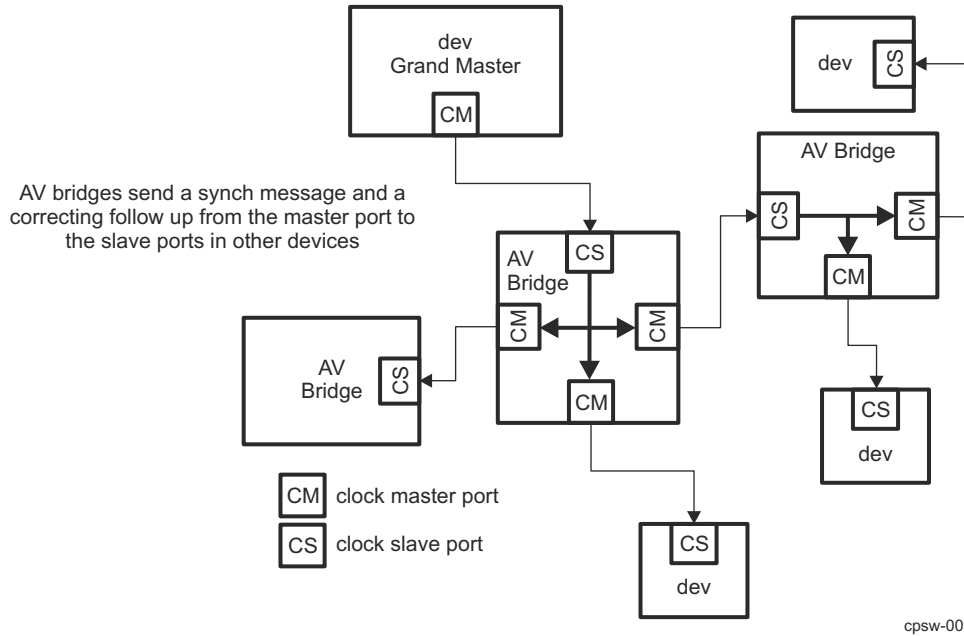

cpsw-009

Figure 13-102. AVB Network & PTP Clock Entities

The media transport protocols that work within the AVB framework are:

13.2.1.4.6.8.1.1 IEEE 1722: "Layer 2 Transport Protocol for Time-Sensitive Streams"

AVBTP or 1722 sits above the IEEE 802.1 AVB plumbing and below the application layer. It acts as the conduit between an Ethernet MAC and a streaming application. AVBTP abstracts the underlying network transmission channel to enable the virtual connection of distributed audio and video CODECs over reliable Ethernet networks. A complete AVBTP Ethernet packet is shown in Figure 13-103 and illustrates how IEC 61883-6 AM824 uncompressed audio samples are encapsulated in an Ethernet frame.

IEEE 1722 Packet Construction

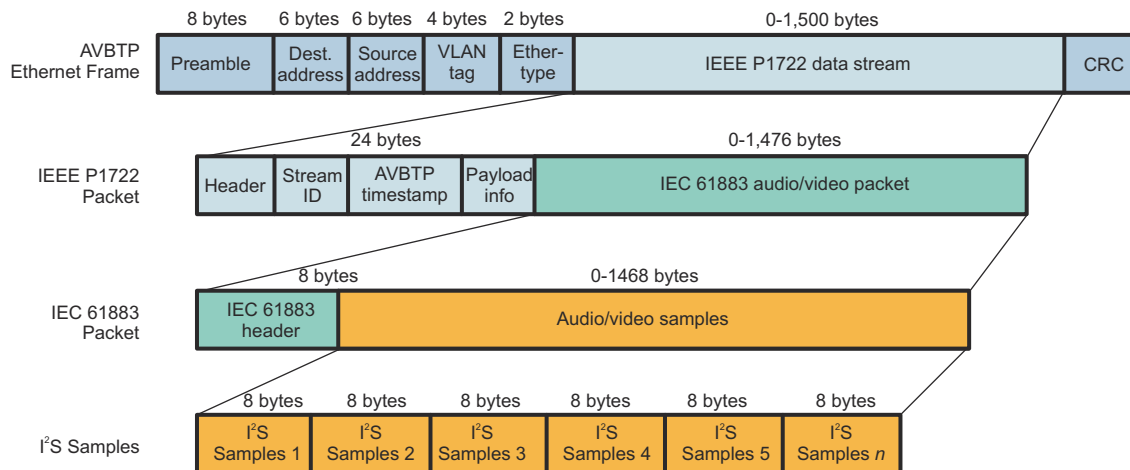

cpsw-010

Figure 13-103. IEEE 1722 Packets

1722 or AVBTP Presentation Time and Synchronization:

Synchronization in an AVB network starts with the Precision Time Protocol but ends with synchronized media clocks. PTP is responsible for synchronizing all nodes in an AVB network to identical wall clock time; not for

synchronizing media clocks. In other words, PTP does not actually transport synchronized media clocks but instead provides a low-level building block crucial for managing a distributed media synchronization system.

A crucial benefit of this approach is coexistence of multiple, independent media clock domains on an AVB network. Unrelated audio and video streams can simultaneously exist in the same LAN.

2.1.4.6.8.1.1 Cross-timestamping and Presentation Timestamps

AVBTP assumes that AVB node media clocks are clocked by free-running oscillators. It is also assumed that the node's internal concept of wall clock time has been synchronized to the PTP Grandmaster. AVBTP media clock sources embed "AVBTP Presentation Timestamps" in AVBTP streaming packets. Figure 13-104 illustrates the relationship between PTP network time and AVBTP Presentation Timestamps.

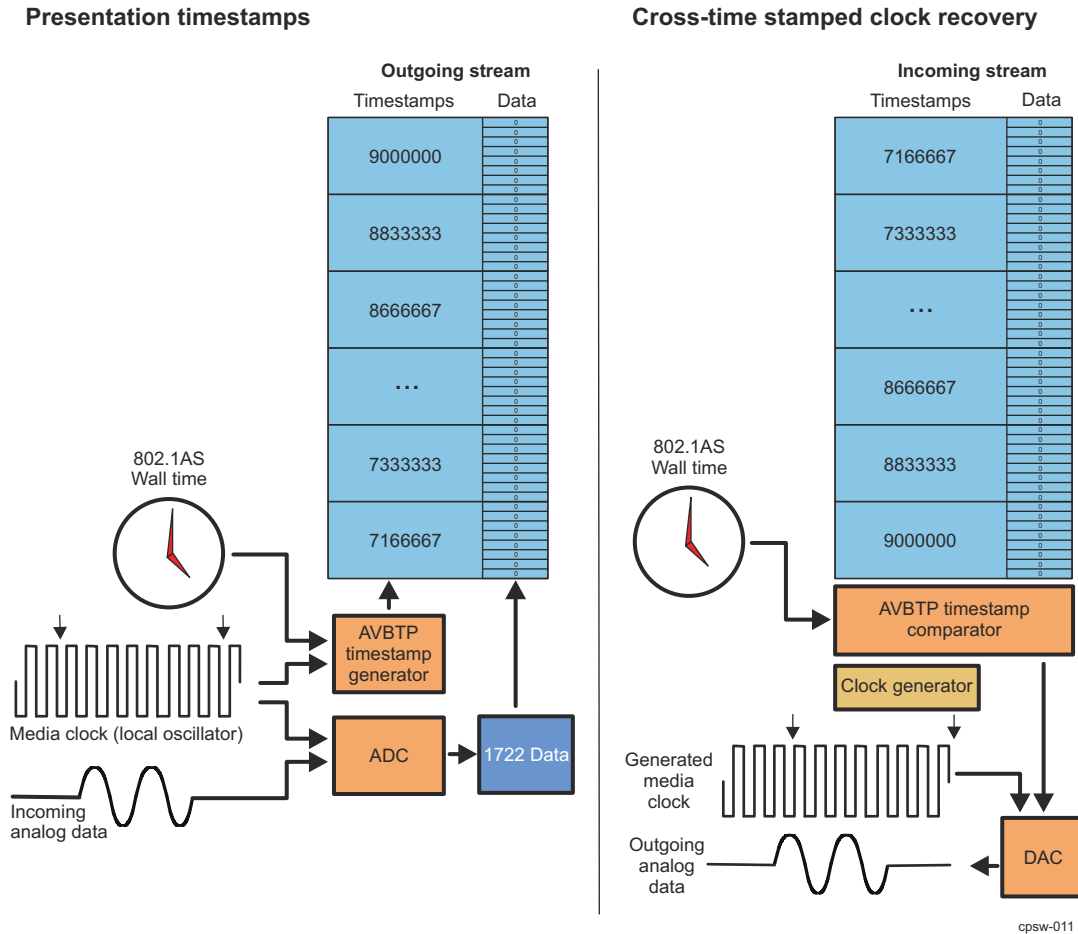

Figure 13-104. Cross Time Stamping and Presentation Timestamps

13.2.1.4.6.8.1.2 IEEE 1733: Extends RTCP for RTP Streaming over AVB-supported Networks

This standard specifies the protocol, data encapsulations, connection management and presentation time procedures used to ensure interoperability between audio and video based end stations that use standard networking services provided by all IEEE 802 networks meeting QoS requirements for time-sensitive applications by leveraging the Real-time Transport Protocol (RTP) family of protocols and IEEE 802.1 Audio/Video Bridging (AVB) protocols.

13.2.1.4.6.8.2 IEEE 802.1Qav: "Virtual Bridged Local Area Networks: Forwarding and Queuing for Time-Sensitive Streams"

This standard allows bridges to provide guarantees for time-sensitive (that is, bounded latency and delivery variation), loss-sensitive real-time audio video (AV) data transmission (AV traffic). It specifies per priority ingress metering, priority regeneration, and timing-aware queue draining algorithms. This standard uses the timing

ADVANCE INFORMATION

derived from IEEE 802.1AS. Virtual Local Area Network (VLAN) tag encoded priority values are allocated, in aggregate, to segregate frames among controlled and non-controlled queues, allowing simultaneous support of both AV traffic and other bridged traffic over and between wired and wireless Local Area Networks (LANs).

Such a guarantee in bandwidth is provided by two functional entities:

- A registration protocol, which registers the service and its maximum network utilization with a device or switch (IEEE 802.1Qat: "Virtual Bridged Local Area Networks - Amendment 9: Stream Reservation Protocol (SRP)")
- A hardware bandwidth management service.
 - Receive policing
 - Transmit rate control.

End Station Behavior

In order for an end station to successfully participate in the transmission and reception of time-sensitive streams, it is necessary for their behavior to be compatible with the operation of the forwarding and queuing mechanisms employed in bridges.

The requirements for end stations that participate as "talkers" i.e., sources of time-sensitive streams are different from the requirements that apply to "listeners", the destination station(s) for the streams.

Talker Behavior

In order for Talker-originated data streams to make use of the credit-based shaper behavior in Bridges, it is a requirement for a Talker to use the priorities that the Bridges in the network recognize as being associated with SR classes exclusively for transmitting stream data.

It is also necessary for the Talker and the Bridges in the path to the Listener(s), to have a common view of the bandwidth required in order to transmit the Talker's streams, and for that bandwidth to be reserved along the path to the Listener(s). This latter requirement can be met by means of stream reservation mechanisms, such as defined in SRP, or by other management means.

End stations that are Talkers shall exhibit transmission behavior for frames that are part of "time-sensitive streams" that is consistent with the operation of the credit-based shaper algorithm, both in terms of the way they transmit frames that are part of an individual data stream, and in terms of the way they transmit stream data frames from a Port.

In effect, the queuing model for a Talker Port (and a Listener port), and for given priorities, can be considered to look like [Figure 13-105](#).

Listener Behavior

The primary requirement for a listener station is that it is capable of buffering the amount of data that could be transmitted for a stream during a time period equivalent to the accumulated maximum jitter that could be experienced by stream data frames in transmission between Talker and Listener.

From the point of view of the specification of the forwarding and queuing requirements for time-sensitive streams, it is assumed that the listener will assess the buffering required for a stream as part of the stream bandwidth reservation mechanisms employed by the implementation.

The credit-based shaper's operation details are beyond the scope of this document.

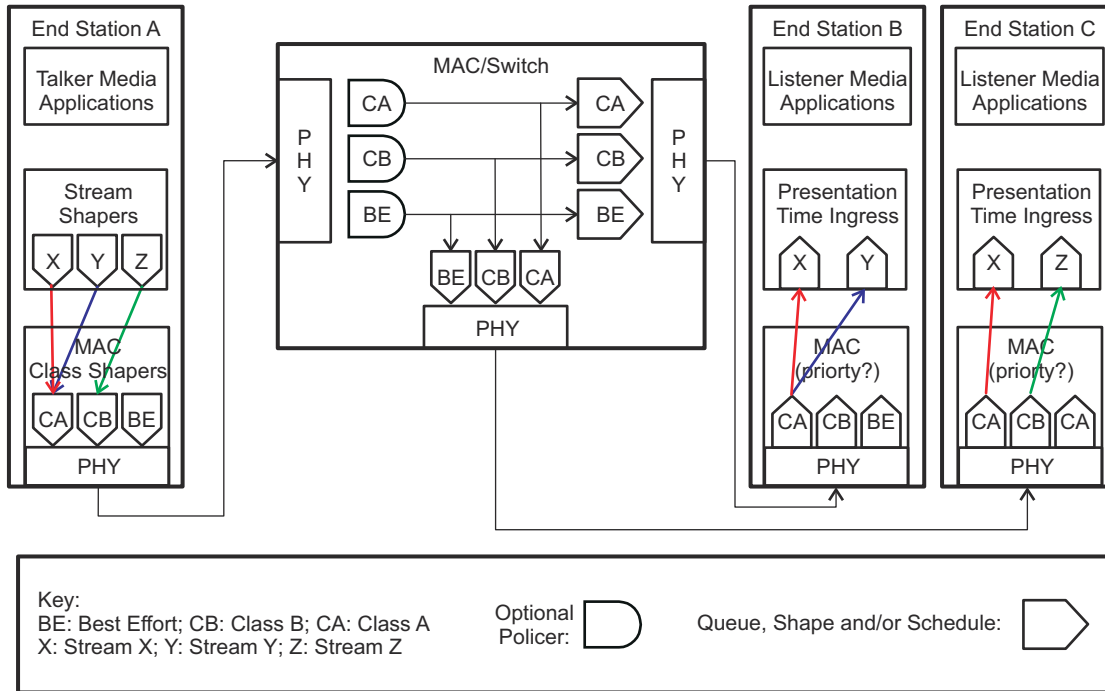

cpsw-012

Figure 13-105. AV Stream Queuing/Policing

13.2.1.4.6.8.2.1 Configuring the Device for 802.1Qav Operation

There is no dedicated register-set to be configured for the time-sensitive stream handling. The list of functional features of CPSW that will have to be configured are:

- DESCRIPTORS and CHANNEL CONFIGURATIONS:
 - CPPI TX and RX descriptors
 - VLAN and Priority tags

Table 13-141. Example of TX Configuration

TX DMA CHANNEL	Packet Priority	Switch Queue Priority
7	7	3
6	5	2
5	3	1
4	1	0

Table 13-142. Example of RX Configuration

RX DMA CHANNEL	Packet Priority	Switch Queue Priority
0	7	0
0	5	0
0	3	0
0	1	0

- ALE Configuration:
 - ALE in VLAN-ware mode, Non-ALE in bypass mode.

13.2.1.4.6.9 Ethernet MAC Sliver

The Ethernet port peripheral is compliant to the IEEE Std 802.3 Specification. Half-duplex mode is supported in 10/100 Mbps mode, but not in 1000 Mbps (gigabit) mode.

Features:

- Synchronous 10/100/1000 Mbit operation
- RMII/RGMII Interface
- Hardware Error handling including CRC
- Full-Duplex Gigabit operation (half-duplex gigabit is not supported)
- EtherStats and 802.3Stats RMON statistics gathering support for external statistics collection module
- Transmit CRC generation selectable on a per channel basis
- Emulation Support
- VLAN Aware Mode Support
- Hardware flow control
- Programmable Inter Packet Gap (IPG).

13.2.1.4.6.9.1 Ethernet MAC Sliver Overview

13.2.1.4.6.9.1.1 CRC Insertion

The MAC generates and appends a 32-bit Ethernet CRC onto the transmitted data, if the transmit packet header PASS_CRC bit is 0h. For the Ethernet port generated CRC case, a CRC at the end of the input packet data is not allowed.

If the header word PASS_CRC bit is set, then the last four bytes of the TX data are transmitted as the frame CRC. The four CRC data bytes should be the last four bytes of the frame and should be included in the packet byte count value. The MAC performs no error checking on the outgoing CRC when the PASS_CRC bit is set.

13.2.1.4.6.9.1.2 MTXER

The MTXER signal is only used for EEE. If an underflow condition occurs on a transmitted frame, the frame CRC will be inverted to indicate the error to the network. Underflow is a hardware error.

13.2.1.4.6.9.1.3 Adaptive Performance Optimization (APO)

The Ethernet MAC port incorporates Adaptive Performance Optimization (APO) logic that may be enabled by setting the TX_PACE bit in the CPSW_PN_MAC_CONTROL_REG register. Transmission pacing to enhance performance is enabled when set. Adaptive performance pacing introduces delays into the normal transmission of frames, delaying transmission attempts between stations, reducing the probability of collisions occurring during heavy traffic (as indicated by frame deferrals and collisions) thereby increasing the chance of successful transmission.

When a frame is deferred, suffers a single collision, multiple collisions or excessive collisions, the pacing counter is loaded with an initial value of 31. When a frame is transmitted successfully (without experiencing a deferral, single collision, multiple collision or excessive collision) the pacing counter is decremented by one, down to zero.

With pacing enabled, a new frame is permitted to immediately (after one IPG) attempt transmission only if the pacing counter is zero. If the pacing counter is non zero, the frame is delayed by the pacing delay, a delay of approximately four inter-packet gap delays. APO only affects the IPG preceding the first attempt at transmitting a frame. It does not affect the back-off algorithm for re-transmitted frames.

13.2.1.4.6.9.1.4 Inter-Packet-Gap Enforcement

The measurement reference for the IPG of 96-bit times is changed depending on frame traffic conditions. If a frame is successfully transmitted without collision, and MCRS is de-asserted within approximately 48-bit times of MTXEN being de-asserted, then 96-bit times is measured from MTXEN. If the frame suffered a collision, or if MCRS is not de-asserted until more than approximately 48-bit times after MTXEN is de-asserted, then 96-bit times (approximately, but not less) is measured from MCRS.

The Ethernet port transmit inter-packet gap (IPG) may be shortened by eight bit times when short gap is enabled and triggered. Setting the [10] TX_SHORT_GAP_ENABLE bit in the CPSW_PN_MAC_CONTROL_REG register enables the gap to be shortened when triggered. The condition is triggered when the ports associated transmit packet FIFO has a user defined number of FIFO blocks used. The associated transmit FIFO blocks used value determines if the gap is shortened, and so on. The CPSW_GAP_THRESH_REG register value determines the short gap threshold. If the FIFO blocks used is greater than or equal to the GAP_THRESH value then short gap is triggered.

13.2.1.4.6.9.1.5 Back Off

The Gigabit Ethernet Mac Sliver implements the 802.3 binary exponential back-off algorithm.

13.2.1.4.6.9.1.6 Programmable Transmit Inter-Packet Gap

The transmit inter-packet gap (IPG) is programmable through the CPSW_PN_MAC_CONTROL_REG register. The default value is decimal 12. The transmit IPG may be increased to the maximum value of 1FFh. Increasing the IPG is not compatible with transmit pacing. The short gap feature will override the increased gap value, so the short gap feature may not be compatible with an increased IPG.

13.2.1.4.6.9.1.7 Speed, Duplex and Pause Frame Support Negotiation

The Ethernet port can operate in half duplex or full duplex in 10/100 Mbit modes, and can operate in full duplex only in 1000 Mbit mode. Pause frame support is included in 10/100/1000 Mbit modes as configured by the host.

13.2.1.4.6.9.2 RMII Interface

The CPRMII peripheral is compliant to the RMII specification document.

13.2.1.4.6.9.2.1 Features

- Source Synchronous 10/100 Mbit operation
- Full and Half Duplex support

13.2.1.4.6.9.2.2 RMII Receive (RX)

The CPRMII receive (RX) interface converts the input data from the external RMII PHY (or switch) into the required MII (CPGMAC) signals. The carrier sense and collision signals are determined from the RMII input data stream and transmit inputs as defined in the RMII specification.

An asserted RMII_RXER on any di-bit in the received packet will cause an MII_RXER assertion to the CPGMAC during the packet. In 10Mbps mode, the error is not required to be duplicated on 10 successive clocks. Any di-bit which has an asserted RMII_RXER during any of the 10 replications of the data will cause the error to be propagated.

Any received packet that ends with an improper nibble boundary aligned RMII_CRSDV toggle will issue an MII_RXER during the packet to the CPGMAC. Also, a change in speed or duplex mode during packet operations will cause packet corruption.

The CPRMII can accept receive packets with shortened preambles, but 0x55 followed by a 0x5D is the shortest preamble that will be recognized (1 preamble byte with the start of frame byte). At least one byte of preamble with the start of frame indicator is required to begin a packet. An asserted RMII_CRSDV without at least a single correct preamble byte followed by the start of frame indicator will be ignored.

13.2.1.4.6.9.2.3 RMII Transmit (TX)

The CPRMII transmit (TX) interface converts the CPGMAC MII input data into the RMII transmit format. The data is then output to the external RMII PHY.

The CPGMAC does not source the transmit error (MII_TXERR) signal. Any transmit frame from the CPGMAC with an error (underrun) will be indicated as an error by an error CRC. Transmit error is assumed to be de-asserted at all times and is not an input into the CPRMII module. Zeroes are output on RMII_TXD[1:0] for each clock that RMII_TXEN is de-asserted.

13.2.1.4.6.9.3 RGMII Interface

The CPRGMII peripheral is compliant to the RGMII specification document.

13.2.1.4.6.9.3.1 Features

- Supports 1000/100/10 Mbps speed
- Full and Half Duplex support (CPGMAC supports only Full duplex in Gigabit mode).
- MII mode support
- Energy Efficient Ethernet Support

13.2.1.4.6.9.3.2 RGMII Receive (RX)

The CPRGMII receive (RX) interface converts the source synchronous DDR input data from the external RGMII PHY into the required G/MII (CPGMAC) signals.

13.2.1.4.6.9.3.3 In-Band Mode of Operation

The CPRGMII is operating in the in-band mode of operation when the RGMII_RX_INBAND input is asserted. RGMII_RX_INPUT is asserted by configuring the CTL_EN bit to 1h of the CPSW_PN_MAC_CONTROL_REG register. The link status, duplexity, and speed are determined from the RGMII input data stream RXD[3:0] when RX_CTL is deasserted, as defined in the RGMII specification. The PHY might need to be configured beforehand to output in-band data. The in-band data is indicated as shown in [Table 13-143](#).

Table 13-143. In-Band Data

RXD3	RXD[2:1]		RXD0
Duplex status:	Link Speed:	RXC_CLK Speed:	Link Status:
0h: half-duplex	0h: 10-Mbps mode	2.5 MHz	0h: Link is down
1h: full-duplex	1h: 100-Mbps mode	25 MHz	1h: Link is up
	2h: 1000-Mbps mode	125 MHz	
	3h: Reserved	Reserved	

13.2.1.4.6.9.3.4 Forced Mode of Operation

The CPRGMII is operating in the forced mode of operation when the RGMII_RX_INBAND input is deasserted by setting to 0h bit CTL_EN of the CPSW_PN_MAC_CONTROL_REG register. In the forced mode of operation, the in-band data is ignored if present. The link status is forced high, and the duplexity and speed are determined from the CPSW_PN_MAC_CONTROL_REG[0] FULLDUPLEX and CPSW_PN_MAC_CONTROL_REG[7] GIG bits. If bit [7] GIG = 1h, then CPRGMII is operating in Gigabit mode. If bit [7] GIG is cleared (0h), then CPRGMII is operating in 100 Mbps mode.

13.2.1.4.6.9.3.5 RGMII Transmit (TX)

The CPRGMII transmit (TX) interface converts the CPGMAC G/MII input data into the DDR RGMII format. The DDR data is then output to the external PHY.

The CPGMAC does not source the transmit error (TXERR) signal. Any transmit frame from the CPGMAC with an error (underrun) will be indicated as an error by an error CRC. Transmit error is assumed to be deasserted at all times and is not an input into the CPRGMII module.

In 10/100 Mbps mode, the TXD[7:0] data bus uses only the lower nibble. The CPRGMII will output the lower nibble twice in 10/100 Mbps mode to avoid unnecessary signal switching.

Packets will be precluded from transmission through the CPRGMII module for 4096 transmit clocks after the rising edge of RGMII_LINK. Packet transmission will begin on the first TX_CTL rising edge after the 4096 transmit clock count has expired.

13.2.1.4.6.9.4 Frame Classification

Received frames are proper (good) frames if they are between 64 and CPSW_P0_RX_MAXLEN_REG[13-0] RX_MAXLEN in length (inclusive) and contain no errors (code/align/CRC).

Received frames are long frames if their frame count exceeds the value in the CPSW_P0_RX_MAXLEN_REG/ CPSW_PN_RX_MAXLEN_REG register. The register reset (default) value is 1518 (decimal). Long received frames are either oversized or jabber frames. Long frames with no errors are oversized frames. Long frames with CRC, code, or alignment errors are jabber frames.

Received frames are short frames if their frame count is less than 64 bytes. Short frames that contain no errors are undersized frames. Short frames with CRC, code, or alignment errors are fragment frames. If RX_CSF_EN bit in CPSW_PN_MAC_CONTROL_REG is set to 1h, undersized frames from 33 to 63 bytes will be forwarded only to the host on a best effort basis (meaning that the ALE may or may not be able to keep up with the packet rate and the short packet may be dropped due to bandwidth limitations). If RX_CSF_EN and RX_CEF_EN in

CPSW_PN_MAC_CONTROL_REG are set, fragment frames from 33 to 63 bytes will also be forwarded only to the host on a best effort basis. Ethernet port received frames shorter than 33 bytes are dropped in all cases.

A received long packet will always contain RX_MAXLEN number of bytes transferred to memory (if CPSW_PN_MAC_CONTROL_REG[22]RX_CEF_EN = 1h). An example with RX_MAXLEN = 1518 is:

- If the frame length is 1518, then the packet is not a long packet and there will be 1518 bytes transferred to memory.
- If the frame length is 1519, there will be 1518 bytes transferred to memory. The last three bytes will be the first three CRC bytes.
- If the frame length is 1520, there will be 1518 bytes transferred to memory. The last two bytes will be the first two CRC bytes.
- If the frame length is 1521, there will be 1518 bytes transferred to memory. The last byte will be the first CRC byte.

If the frame length is 1522, there will be 1518 bytes transferred to memory. The last byte will be the last data byte.

13.2.1.4.6.9.5 Receive FIFO Architecture

This section describes the architecture of the Ethernet port's receive FIFOs. Internal to the Gigabit Ethernet switch, all Ethernet ports have an identical associated packet FIFO. Each transmit packet FIFO contains eight logical transmit queues (priority 0 through 7 with 7 the highest priority). Each transmit FIFO memory contains 81,920 bytes total organized as 2560 by 256-bit words. Each FIFO also contains a single memory for the receive queue. Each receive FIFO memory contains a total of 32768 bytes total organized as 1024 by 256-bit words.

13.2.1.4.6.10 Embedded Memories

Table 13-144. Embedded Memories

Memory Type Description	Number of Instances	
Single-port 3072-word × 64 RAM	1	(Combined FIFO RAM)
Single-port 128-word × 28-bit RAM	1	1 (EST)

13.2.1.4.6.11 Memory Error Detection and Correction

The CPSW error detection and correction logic uses the ECC Aggregator Module.

The ECC CPSW_ECC_VECTOR register is used to select which ECC RAM's status and control registers are currently being read or written as shown in [Table 13-145](#). The CPSW FIFO RAMs implement ECC only on packet headers. The packet data is protected by Ethernet CRC. The ALE and EST RAMs have complete ECC as normal.

Table 13-145. ECC RAM to CPSW RAM Mapping

ECC RAM Number	CPSW RAM
0	ALE RAM
1	Port 0 FIFO RAM

13.2.1.4.6.11.1 Packet Header ECC

Only packet headers bits are protected by ECC in the FIFO RAMs. The ECC_ERR_CTRL1[31-0] ECC_ROW bit is used to activate a row address where force single-bit error or force double-bit error needs to be applied. ECC_ERR_CTRL2 [15-0] ECC_BIT1 is implemented to determine which bit of the header is flipped for an SEC error when the ECC_CRC_MODE bit is cleared in the CPSW_CONTROL_REG register. The ECC status registers return the RAM row address where the single or double-bit error has occurred (ECC_ERR_STAT2[31-0] ECC_ROW) along with the bit position in the RAM data that is in error (ECC_ERR_STAT1[31-16] ECC_BIT1 value). Forcing double-bit errors in testing can cause indeterminate operation if multiple used packet header bits are flipped given that only single-bit errors are fixed by the ECC logic. Header bits 207 down to 200 are not currently used in the CPSW and may be used to test double bit errors without the possibility of requiring a reset for the switch to recover from the double bit error. No header bits are flipped when ECC_CRC_MODE is set to 1h. Either the RX_ECC_ERR_EN (enable receive ECC error operations) or the TX_ECC_ERR_EN (enable transmit ECC error operations) bits must be set in the CPSW_P0_CONTROL_REG register to test ECC header errors.

The header ECC code is stored in bits 255 down to 208. If any bit is flipped in the ECC code, the flipped bit will be corrected, but the index of the flipped bit will be reported as bit zero. This implies that when the aggregator reports that there is a SEC on bit 0, it can mean two things: either SEC on data bit 0 or SEC somewhere inside the ECC code. Any packet header with ECC error issues a pulse interrupt (ECC_PULSE_INTR) as does an ALE RAM ECC error.

13.2.1.4.6.11.2 Packet Protect CRC

Each packet received without error is passed through the CPSW_2G memories with a generated Ethernet protect CRC. The protect CRC is checked on egress for correctness and removed. If the CRC is correct (no RAM bit errors), then the packet is output with the selected port CRC type. If a protect CRC error is detected on host egress then the TXST_DROP signal will be asserted so that the packet is dropped to the host. If a protect CRC error is detected on Ethernet egress then the egress CRC will be generated on the packet and at least one byte of the CRC will be inverted on output. CRC memory protect errors do not assert the ECC_PULSE_INTR signal. CRC memory protect errors are counted in the associated port statistics registers and issue an interrupt on STAT_PEND_INTR if any CRC memory protect error occurs (and the statistics for that port are enabled). When the ECC_CRC_MODE bit in the CPSW_CONTROL_REG register is set, the ECC_ERR_CTRL2 [15-0] ECC_BIT1 bit field will flip the associated column bit in any FIFO memory read operation, inducing a CRC protect error when the protect CRC is checked. No header bits are flipped when ECC_CRC_MODE is set. Either the RX_ECC_ERR_EN or the TX_ECC_ERR_EN bits must be set in the CPSW_P0_CONTROL_REG register to test packet CRC errors.

13.2.1.4.6.11.3 Aggregator RAM Control

The ECC logic for each FIFO RAM (receive and transmit) is divided into eight separate ECC encoders/decoders that encode/decode 26-bits of data each. Each of the 8 encoders (0 to 7) generates 6-bits of ECC code (48 code bits total), and each of the eight decoders (0 to 7) checks 6-bits of ECC code across the 26-bits of data (208 data bits total). The 48-bits of ECC code are passed through the RAM in the upper 48 unused bits in the header word. The header data bits and ECC code bits are shown in [Table 13-146](#). The [15-0] ECC_BIT1 value returned on

error is a 16-bit value that is the concatenation of 5 bits of zero, 3 bits of the encoder/decoder number (0 to 7), 3 bits of zero, and 5 bits of index into the indicated 26-bit encoder/decoder.

For example, an ECC_BIT1 value of 0x0308 is bit 8 of encoder/decoder 3, which is header bit 86 (that is, $(26 \times 3) + 8$).

Table 13-146. ECC Submodule Header Data Bit to Encoder/Decoder Mapping

Header Data Bits	Encoder/Decoder
25:0	Encoder/Decoder 0 Data
51:26	Encoder/Decoder 1 Data
77:52	Encoder/Decoder 2 Data
103:52	Encoder/Decoder 3 Data
129:104	Encoder/Decoder 4 Data
155:130	Encoder/Decoder 5 Data
181:156	Encoder/Decoder 6 Data
207:182	Encoder/Decoder 7 Data
213:208	Encoder/Decoder 0 ECC
219:214	Encoder/Decoder 1 ECC
225:220	Encoder/Decoder 2 ECC
231:226	Encoder/Decoder 3 ECC
237:232	Encoder/Decoder 4 ECC
243:238	Encoder/Decoder 5 ECC
249:244	Encoder/Decoder 6 ECC
255:250	Encoder/Decoder 7 ECC

13.2.1.4.6.12 Ethernet Port Flow Control

The Ethernet port have flow control available for transmit and receive. Transmit flow control stops the Ethernet port from transmitting packets to the wire (switch egress) in response to a received pause frame. Transmit flow control does not depend on FIFO usage.

The Ethernet port have flow control available for receive operations (packet ingress). Ethernet port receive flow control is initiated when enabled and triggered. Packets received on an Ethernet port can be sent to the CPPI port. The destination port can trigger the receive Ethernet port flow control. An Ethernet destination port triggers another Ethernet receive flow control when the destination port is full.

When a packet is received on an Ethernet port interface with enabled flow control the below occurs:

- The packet will be sent to all ports that currently have room to take the entire packet.
- The packet will be retried until successful to all ports that indicate they don't have room for the packet.

The flow control trigger to the Ethernet port will be asserted until the packet has been sent, and there is room in the logical receive FIFO for packet runout from another flow control trigger (RX_BLK_CNT = 0h). Ethernet port receive flow control is disabled by default on reset. Ethernet port receive flow control requires that the RX_FLOW_EN bit in CPSW_PN_MAC_CONTROL_REG be set to 1h. When receive flow control is enabled on a port, the port's associated FIFO block allocation must be adjusted. The port RX allocation must increase from the default three blocks to accommodate the flow control runout. A corresponding decrease in the TX block allocation is required. If a sending port ignores a pause frame then packets may overrun on receive (and be dropped) but will not be dropped on transmit.

13.2.1.4.6.12.1 Ethernet Receive Flow Control

For every Ethernet port to be configured for full-duplex receive flow control, write a value of decimal 7 to the CPSW_PN_MAX_BLKs_REG[7-0] RX_MAX_BLKs bit field, and a value of decimal 13 to the CPSW_PN_MAX_BLKs_REG[15-8] TX_MAX_BLKs register. This re-allocation allows for flow control runout on the receive FIFO at the expense of FIFO memory on the Ethernet transmit side. 10/100Mbps half-duplex

collision based receive flow control does not need this re-allocation. Receive flow control is enabled by the RX_FLOW_EN bit in the CPSW_PN_MAC_CONTROL_REG register.

13.2.1.4.6.12.1.1 Collision Based Receive Buffer Flow Control

Collision-based receive buffer flow control provides a means of preventing frame reception when the port is operating in half-duplex mode (FULLDUPLEX is cleared in CPSW_PN_MAC_CONTROL_REG). When receive flow control is enabled and triggered, the port will generate collisions for received frames. The jam sequence transmitted will be the twelve byte sequence C3.C3.C3.C3.C3.C3.C3.C3.C3.C3.C3.C3 (hex). The jam sequence will begin no later than approximately as the source address starts to be received. Note that these forced collisions will not be limited to a maximum of 16 consecutive collisions, and are independent of the normal back-off algorithm. Receive flow control does not depend on the value of the incoming frame destination address. A collision will be generated for any incoming packet, regardless of the destination address.

13.2.1.4.6.12.1.2 IEEE 802.3X Based Receive Flow Control

IEEE 802.3x based receive flow control provides a means of preventing frame reception when the port is operating in full-duplex mode (FULLDUPLEX bit is set in the CPSW_PN_MAC_CONTROL_REG register). When receive flow control is enabled and triggered, the port will transmit a pause frame to request that the sending station stop transmitting for the period indicated within the transmitted pause frame.

The Ethernet port will transmit a pause frame to the reserved multicast address at the first available opportunity (immediately if currently idle, or following the completion of the frame currently being transmitted). The pause frame will contain the maximum possible value for the pause time (FFFFh). The MAC will count the receive pause frame time (decrements FF00h down to 0) and retransmit an outgoing pause frame if the count reaches zero. When the flow control request is removed, the MAC will transmit a pause frame with a zero pause time to cancel the pause request.

Note that transmitted pause frames are only a request to the other end station to stop transmitting. Frames that are received during the pause interval will be received normally (provided the RX FIFO is not full at which time the receive FIFO will overrun and CPSW_STAT0_RX_BOTTOM_OF_FIFO_DROP/ CPSW_STAT1_RX_BOTTOM_OF_FIFO_DROP[31-0] COUNT value will increment).

Pause frames will be transmitted if enabled and triggered regardless of whether or not the port is observing the pause time period from an incoming pause frame.

The Ethernet port will transmit pause frames as described below:

- The 48-bit reserved multicast destination address 01.80.C2.00.00.01.
- The 48-bit source address - from SL_SA[47-0] input.
- The 16-bit length/type field containing the value 88.08
- The 16-bit pause opcode equal to 00.01
- The 16-bit pause time value FF.FF. A pause-quantum is 512 bit-times. Pause frames sent to cancel a pause request will have a pause time value of 00.00.
- Zero padding to 64-byte data length (The Ethernet port will transmit only 64 byte pause frames).
- The 32-bit frame-check sequence (CRC word).

All quantities above are hexadecimal and are transmitted most-significant byte first. The least-significant bit is transferred first in each byte.

If CPSW_PN_MAC_CONTROL_REG[3] RX_FLOW_EN is cleared to 0h while the pause time is nonzero, then the pause time will be cleared to 0h and a 0 count pause frame will be sent.

13.2.1.4.6.12.2 Flow Control Trigger

Receive flow control is triggered (when enabled), when the number of words in the receive FIFO is greater than or equal to the value written in the CPSW_PN_RX_FLOW_THRESH_REG[8-0] COUNT bit field. The flow control packet runout is then contained in the remainder of the receive FIFO.

13.2.1.4.6.12.3 Ethernet Transmit Flow Control

Incoming pause frames are acted upon, when enabled, to prevent the Ethernet port from transmitting any further frames. Incoming pause frames are only acted upon when the [0] FULLDUPLEX and [4] TX_FLOW_EN bits

in the CPSW_PN_MAC_CONTROL_REG register are set. Pause frames are not acted upon in half-duplex mode. Pause frame action will be taken if enabled, but normally the frame will be filtered and not transferred to memory. MAC control frames will be transferred to memory if the [24] RX_CMF_EN (RX Copy MAC Control Frames Enable) bit in the CPSW_PN_MAC_CONTROL_REG register is set. The [4] TX_FLOW_EN and [0] FULLDUPLEX bits effect whether or not MAC control frames are acted upon, but they have no effect upon whether or not MAC control frames are transferred to memory or filtered.

Pause frames are a subset of MAC Control Frames with an opcode field = 0001h. Incoming pause frames will only be acted upon by the port if:

- [4] TX_FLOW_EN is set in CPSW_PN_MAC_CONTROL_REG register, and
- the RX maximum frame length is 64 bytes inclusive (CPSW_PN_RX_MAXLEN_REG[13-0] RX_MAXLEN), and
- the frame contains no CRC error or align/code errors.

The pause time value from valid frames will be extracted from the two bytes following the opcode. The pause time will be loaded into the port's transmit pause timer and the transmit pause time period will begin.

If a valid pause frame is received during the transmit pause time period of a previous transmit pause frame then:

- if the destination address is not equal to the reserved multicast address or any enabled or disabled unicast address, then the transmit pause timer will immediately expire, or
- if the new pause time value is zero then the transmit pause timer will immediately expire, else the port transmit pause timer will immediately be set to the new pause frame pause time value. (Any remaining pause time from the previous pause frame will be discarded).

If [4] TX_FLOW_EN in CPSW_PN_MAC_CONTROL_REG register is cleared, then the pause-timer will immediately expire.

The port will not start the transmission of a new data frame any sooner than 512-bit times after a pause frame with a non-zero pause time has finished being received (MRXDV going inactive). No transmission will begin until the pause timer has expired (the port may transmit pause frames in order to initiate outgoing flow control). Any frame already in transmission when a pause frame is received will be completed and unaffected.

Incoming pause frames consist of the below:

- A 48-bit destination address equal to:
 - The reserved multicast destination address 01.80.C2.00.00.01, or the Ethernet port SL_SA [47:0] input.
- The 48-bit source address of the transmitting device.
- The 16-bit length/type field containing the value 88.08
- The 16-bit pause opcode equal to 00.01
- The 16-bit CPSW_PN_MAC_TX_PAUSETIMER_REG[15-0] TX_PAUSETIMER. A pause-quantum is 512 bit-times.
- Padding to 64-byte data length.
- The 32-bit frame-check sequence (CRC word).

All quantities above are hexadecimal and are transmitted most-significant byte first. The least-significant bit is transferred first in each byte.

The padding is required to make up the frame to a minimum of 64 Bytes. The standard allows pause frames longer than 64 Bytes to be discarded or interpreted as valid pause frames. The Ethernet port will recognize any pause frame between 64 Bytes and CPSW_PN_RX_MAXLEN_REG[13-0] RX_MAXLEN bytes in length.

13.2.1.4.6.13 Energy Efficient Ethernet Support (802.3az)

Energy Efficient Ethernet (EEE) allows the LPSC to turn off the module clock during inactive periods as determined by network and host traffic. The module can then be awakened by host queued transmit packet(s) or by a port's external Ethernet PHY. The module EEE clock stop interface is used by the external controller to control module EEE operations. EEE operations are configured as shown below:

1. The 12-bit EEE clock pre-scale value is written to the CPSW_EEE_PRESCALE_REG register. The pre-scaler is used to clock all EEE-related counters

2. The port Idle to LPI count values (CPSW_PN_IDLE2LPI_REG[23-0] COUNT) are written with the desired values
3. The port LPI to Wake count values (CPSW_PN_LPI2WAKE_REG[23-0] COUNT) are written with the desired values
4. The [0] EEE_EN bit is set in the switch CPSW_SS_CONTROL_REG register

EEE operation can begin after configuration. The host allows (through LPSC) the CPSW to enter a low power state by asserting the EEE_CLKSTOP_REQ signal. There are no requirements on host queues or traffic in order for the host to assert or de-assert EEE_CLKSTOP_REQ to the CPSW.

Each Ethernet port has a transmit and a receive LPI (low power indicate) state. The PHY indicates LPI by asserting MRXER with a MRXD[7:0] value of 0x01 while MRXDV is deasserted (inter-packet gap). The Ethernet transmit port indicates LPI after the CPSW_PN_IDLE2LPI_REG value has been counted (the transmit port has gone idle for the configured amount of time). If another packet is received for transmit during the count then the count is restarted. When the transmit port has been idle for the Idle to LPI time, the transmit port enters the LPI state and indicates LPI to the associated PHY. The LPI is indicated to the external PHY by an asserted MTXER with a MTXD[7:0] while MTXEN is deasserted (inter-packet gap). The CPPI (port 0) LPI state includes transmit and receive. The CPPI LPI state is entered when the CPPI transmit and receive have both been idle for the Idle to LPI time (CPSW_P0_IDLE2LPI_REG). The Idle to LPI time value for all ports must be large relative to the switch latency to ensure that the count is not able to complete between successive packets.

Note

External PHY signaling has the following conditions:

- RGMII is a DDR interface. TXEN and TXER are the sampled values of TX_CTL at the rising and the falling TXC edges, respectively. RXDV and RXER are the sampled values of RX_CTL at the rising and the falling RXC clock edges, respectively
 - In RMII mode, EEE is not supported.
-

When all transmit and receive ports are in the LPI state (CPSW LPI state), the EEE_CLKSTOP_ACK signal is asserted, and the LPSC is allowed to stop the module clock. When EEE_CLKSTOP_ACK is asserted, the clock may be turned on and off as desired by the host. The host is allowed to restart the clock, perform slave read/write operations to the CPSW memory address space, and then turn off the clock again while EEE_CLKSTOP_ACK is asserted.

The software can remove and disable from re-entering the CPSW LPI state by restarting the module clock and then de-asserting EEE_CLKSTOP_REQ. There must be at least one rising edge of the clock before EEE_CLKSTOP_REQ is de-asserted. The module EEE_CLKSTOP_ACK output signal will be deasserted on the clock after the de-assertion of EEE_CLKSTOP_REQ. The host may queue CPPI receive packets at any time without regard to the CPSW module LPI state. The Host must deassert EEE_CLKSTOP_REQ on wakeup for a minimum of two clock periods. If EEE_CLKSTOP_REQ is deasserted for less than 5 clock periods for a wakeup event from the host to a particular Ethernet port (or visa versa), then the wakeup event will not cause the other Ethernet port to awaken.

The external Ethernet PHY's can also wakeup the LPSC by removing the Ethernet receive LPI indication. If the CPSW module is in Idle state with EEE_CLKSTOP_ACK asserted and the receive LPI indication is removed, the EEE_CLKSTOP_WAKEUP signal will be asynchronously asserted. On wakeup, the LPSC restarts the clock and de-assert the EEE_CLKSTOP_REQ signal. The EEE_CLKSTOP_WAKEUP signal will be synchronously deasserted with EEE_CLKSTOP_ACK. Upon the deassertion of EEE_CLKSTOP_REQ, the Ethernet ports will count the CPSW_PN_LPI2WAKE_REG time for each port at which time the port is available for transmit.

13.2.1.4.6.14 Ethernet Switch Latency

When CPSW is configured as a store and forward switch, the switch latency is defined as the amount of time between the end of packet reception of the received packet to the start of the output packet transmit.

The store and forward latency is shown in [Table 13-147](#):

Table 13-147. Switch Latency

Mode	Latency
Gig (1000)	880 ns
100	1.3 μ s
10	6.5 μ s

13.2.1.4.6.15 MAC Emulation Control

The emulation control input (EMUSUSP) and submodule emulation control registers allow CPSW operation to be completely or partially suspended. Each Ethernet port has associated emulation control registers (CPSW_EM_CONTROL_REG and CPSW_PN_MAC_EMCONTROL_REG). The submodule emulation control registers must be accessed to facilitate CPSW emulation control. The CPSW module enters the emulation suspend state if all three submodules are configured for emulation suspend and the emulation suspend input is asserted. A partial emulation suspend state is entered if one or two submodules is configured for emulation suspend and the emulation suspend input is asserted. Emulation suspend occurs at packet boundaries. The emulation control feature is implemented for compatibility with other peripherals.

Ethernet port Emulation Control

The emulation control input (TBEMUSUP) and register bits (SOFT and FREE bits in the CPSW_PN_MAC_EMCONTROL_REG register) allow Ethernet port operation to be suspended. When the emulation suspend state is entered, the Ethernet port will stop processing receive and transmit frames at the next frame boundary. Any frame currently in reception or transmission will be completed normally without suspension. For receive, frames that are detected by the Ethernet port after the suspend state is entered are ignored.

Table 13-148 shows the operations of the emulation control input and register bits.

Table 13-148. Emulation Control Input

EMUSUSP	SOFT	FREE	Description
0	X	X	Normal Operation
1	0	0	Normal Operation
1	1	0	Emulation Suspend
1	X	1	Normal Operation

13.2.1.4.6.16 MAC Command IDLE

The CMD_IDLE bit in the CPSW_PN_MAC_CONTROL_REG register allows MAC operation to be suspended. When the idle state is commanded, the MAC will stop processing receive and transmit frames at the next frame boundary. Any frame currently in reception or transmission will be completed normally without suspension. For transmission, any complete or partial frame in the TX cell FIFO will be transmitted. For receive, frames that are detected by the MAC after the suspend state is entered are ignored. No statistics will be kept for ignored frames. Commanded idle is similar in operation to emulation control and clock stop.

13.2.1.4.6.17 CPSW Network Statistics

The CPSW has a set of statistics that record events associated with frame traffic on selected switch ports. The statistics values are cleared to zero 38 clocks after the rising edge of CPSW0_RST. When one or more port enable (Pn_STAT_EN) bits in the CPSW_STAT_PORT_EN_REG register are set, all statistics registers are write to decrement. The value written will be subtracted from the register value with the result being stored in the register. If a value greater than the statistics value is written, then zero will be written to the register (writing 0xFFFF FFFF clears a statistics location). When all port enable bits are cleared to zero, all statistics registers are read/write (normal write direct, so writing 0x0000 0000 clears a statistics location). All write accesses must be 32-bit accesses.

The statistics interrupt (STAT_PEND0) will be issued if enabled when any statistics value is greater than or equal to 0x8000 0000. The statistics interrupt is removed by writing to decrement any statistics value greater than

0x8000 0000. The statistics are mapped into internal memory space and are 32-bits wide. All statistics rollover from 0xFFFF FFFF to 0x0000 0000.

[Table 13-149](#) and [Table 13-150](#) summarize network statistics.

13.2.1.4.6.17.1 Rx-only Statistics Descriptions

13.2.1.4.6.17.1.1 Good Rx Frames (Offset = 3A000h)

All ports

The total number of good frames received on the port. A good frame is defined to be:

- Any data or MAC control frame which matched a unicast, broadcast or multicast address, or matched due to promiscuous mode
- Had a length of 64 to RX_MAXLEN bytes inclusive
- Had no CRC error, alignment error or code error.

See the [Section 13.2.1.4.6.17.1.6, Rx Align/Code Errors](#) and [Section 13.2.1.4.6.17.1.5, Rx CRC errors](#) statistic descriptions for definitions of alignment, code and CRC errors.

Overruns have no effect upon this statistic.

13.2.1.4.6.17.1.2 Broadcast Rx Frames (Offset = 3A004h)

All ports

The total number of good broadcast frames received on the port. A good broadcast frame is defined to be:

- Any data or MAC control frame which was destined for address FF.FF.FF.FF.FF.FF
- Had a length of 64 to RX_MAXLEN bytes inclusive
- Had no CRC error, alignment error or code error.

See the [Section 13.2.1.4.6.17.1.6, Rx Align/Code Errors](#) and [Section 13.2.1.4.6.17.1.5, Rx CRC errors](#) statistic descriptions for definitions of alignment, code and CRC errors.

Overruns have no effect upon this statistic.

13.2.1.4.6.17.1.3 Multicast Rx Frames (Offset = 3A008h)

All ports

The total number of good multicast frames received on the port. A good multicast frame is defined to be:

- Any data or MAC control frame which was destined for any multicast address other than FF.FF.FF.FF.FF.FF
- Had a length of 64 to RX_MAXLEN bytes inclusive
- Had no CRC error, alignment error or code error

See the [Section 13.2.1.4.6.17.1.6, Rx Align/Code Errors](#) and [Section 13.2.1.4.6.17.1.5, Rx CRC errors](#) statistic descriptions for definitions of alignment, code and CRC errors.

Overruns have no effect upon this statistic.

13.2.1.4.6.17.1.4 Pause Rx Frames (Offset = 3A00Ch)

Ethernet port N where N = 1 to 2

The total number of IEEE 802.3X pause frames received by the port (whether acted upon or not). Such a frame:

- Contained any unicast, broadcast, or multicast address
- Contained the length/type field value 88.08 (hex) and the opcode 0x0001
- Was of length 64 to RX_MAXLEN bytes inclusive
- Had no CRC error, alignment error or code error
- Pause-frames had been enabled on the port (TX_FLOW_EN = 1h).

The port could have been in either half or full-duplex mode.

See the [Section 13.2.1.4.6.17.1.6, Rx Align/Code Errors](#) and [Section 13.2.1.4.6.17.1.5, Rx CRC errors](#) statistic descriptions for definitions of alignment, code and CRC errors.

Overruns have no effect upon this statistic.

13.2.1.4.6.17.1.5 Rx CRC Errors (Offset = 3A010h)

All ports

The total number of frames received on the port that experienced a CRC error. Such a frame:

- Was any data or MAC control frame which matched a unicast, broadcast or multicast address, or matched due to promiscuous mode
- Was of length 64 to RX_MAXLEN bytes inclusive
- Had no code/align error
- Had a CRC error

Overruns have no effect upon this statistic.

A CRC error is defined to be:

- A frame containing an even number of nibbles, and
- Failing the Frame Check Sequence test.

13.2.1.4.6.17.1.6 Rx Align/Code Errors (Offset = 3A014h)

Ethernet port N where N = 1 to 2

The total number of frames received on the port that experienced an alignment error or code error. Such a frame:

- Was any data or MAC control frame which matched a unicast, broadcast or multicast address, or matched due to promiscuous mode
- Was of length 64 to RX_MAXLEN bytes inclusive
- Had either an alignment error, or a code error.

Overruns have no effect upon this statistic.

An alignment error is defined to be:

- A frame containing an odd number of nibbles
- Failing the Frame Check Sequence test if the final nibble is ignored

A code error is defined to be a frame which has been discarded because the port's MRXER pin driven with a one for at least one bit-time's duration at any point during the frame's reception.

Note

RFC 1757 etherStatsCRCAAlignErrors Ref. 1.5 can be calculated by summing Rx Align/Code Errors and Rx CRC errors.

13.2.1.4.6.17.1.7 Oversize Rx Frames (Offset = 3A018h)

All ports

The total number of oversized frames received on the port. An oversized frame is defined to be:

- Was any data or MAC control frame which matched a unicast, broadcast or multicast address, or matched due to promiscuous mode
- Was greater than RX_MAXLEN in bytes
- Had no CRC error, alignment error, or code error.

See the [Section 13.2.1.4.6.17.1.6, Rx Align/Code Errors](#) and [Section 13.2.1.4.6.17.1.5, Rx CRC errors](#) statistic descriptions for definitions of alignment, code and CRC errors.

Overruns have no effect upon this statistic.

13.2.1.4.6.17.1.8 Rx Jabbers (Offset = 3A01Ch)

All ports

The total number of jabber frames received on the port. A jabber frame:

- Was any data or MAC control frame which matched a unicast, broadcast or multicast address, or matched due to promiscuous mode
- Was greater than RX_MAXLEN in bytes
- Had no CRC error, alignment error or code error

See the [Section 13.2.1.4.6.17.1.6, Rx Align/Code Errors](#) and [Section 13.2.1.4.6.17.1.5, Rx CRC errors](#) statistic descriptions for definitions of alignment, code and CRC errors.

Overruns have no effect upon this statistic.

13.2.1.4.6.17.1.9 Undersize (Short) Rx Frames (Offset = 3A020h)

All ports

The total number of undersized frames received on the port. An undersized frame is defined to be:

- Was any data frame which matched a unicast, broadcast or multicast address, or matched due to promiscuous mode
- Was less than 64 bytes
- Had no CRC error, alignment error, or code error

See the [Section 13.2.1.4.6.17.1.6, Rx Align/Code Errors](#) and [Section 13.2.1.4.6.17.1.5, Rx CRC errors](#) statistic descriptions for definitions of alignment, code and CRC errors.

Overruns have no effect upon this statistic.

13.2.1.4.6.17.1.10 Rx Fragments (Offset = 3A024h)

Ethernet port N where N = 1 to 2

The total number of frame fragments received on the port. A frame fragment is defined to be:

- Any data frame (address matching does not matter)
- Less than 64 bytes long
- Having a CRC error, an alignment error, or a code error
- Not the result of a collision caused by half-duplex, collision-based flow control

See the [Section 13.2.1.4.6.17.1.6, Rx Align/Code Errors](#) and [Section 13.2.1.4.6.17.1.5, Rx CRC errors](#) statistic descriptions for definitions of alignment, code and CRC errors.

Overruns have no effect upon this statistic.

13.2.1.4.6.17.1.11 RX IPG Error (Offset = 3A05Ch)

The total number of 10G frames received on a port that had a correct preamble but did not have at least five bytes of IDLE preceding the frame. This does not indicate if the frame with the IPG error was kept or ignored.

13.2.1.4.6.17.1.12 ALE Drop (Offset = 3A028h)

All ports

The total number of frames received on a port such that the destination address was not equal to the source address and the packet was not destined to the port it was received on, but the frame was not forwarded to any port (the PORT_MASK was zero).

- Any data or MAC control frame which matched a unicast, broadcast or multicast address, or matched due to promiscuous mode
- Any length (including less than 64 bytes and greater than RX_MAXLEN bytes)
- had no CRC error, alignment error, or code error
- the destination address was not equal to the source address
- the packet was not destined for the port it was receive on
- had a zero PORT_MASK

13.2.1.4.6.17.1.13 ALE Overrun Drop (Offset = 3A02Ch)

All ports (non cut-thru mode)

The total number of frames received on a port that were dropped (zero PORT_MASK) due to exceeding the maximum ALE lookup rate (Port 0 should not have ALE Overrun Drops because the ingress rate is controlled to prevent it). This statistic should be zero and when non-zero indicates a system clock issue or indicates that short packets were sent with RX_CSF_EN at a rate that exceeded the maximum lookup rate.

- Any data or MAC control frame which matched a unicast, broadcast or multicast address, or matched due to promiscuous mode
- Any length (including less than 64 bytes and greater than RX_MAXLEN bytes)
- The port has no receive priorities enabled for cut-thru, and
- the maximum ALE lookup rate was exceeded so the lookup was aborted and the packet was dropped.

Ethernet Ports (cut-thru mode)

The total number of received frames on a port that were dropped due to packet errors. This statistic does not count error frames that are sent to the host with a set CPSW_PN_MAC_CONTROL_REG_k[22] RX_CEF_EN or CPSW_PN_MAC_CONTROL_REG_k[24] RX_CMF_EN.

- was any data or MAC control frame, and
- the port has at least one receive priority enabled for cut thru, and
- the received packet was long, mac_control, code, align, crc error, and
- was dropped on receive (not transferred to the host due to error enable bits).

13.2.1.4.6.17.1.14 Rx Octets (Offset = 3A030h)

All ports

The total number of bytes in all good frames received on the port. A good frame is defined to be:

- Any data or MAC control frame which matched a unicast, broadcast or multicast address, or matched due to promiscuous mode
- Of length 64 to RX_MAXLEN bytes inclusive
- Had no CRC error, alignment error or code error

See the [Section 13.2.1.4.6.17.1.6, Rx Align/Code Errors](#) and [Section 13.2.1.4.6.17.1.5, Rx CRC errors](#) statistic descriptions for definitions of alignment, code and CRC errors.

Overruns have no effect upon this statistic.

13.2.1.4.6.17.1.15 Rx Bottom of FIFO Drop (Offset = 3A084h)

Ethernet port N where N = 1 to 2

The total number of frames received on a port that overran the port's receive FIFO and were dropped (bottom of receive FIFO). Port 0 (CPPI receive port) should not drop packets on receive because port 0 receive flow control should be enabled. The Ethernet ports will only drop packets in the receive FIFO when receive flow control is enabled and the sending port ignores sent pause frame and then overruns the receive FIFO. An overrun frame is defined to be:

- Any data or MAC control frame which matched a unicast, broadcast or multicast address, or matched due to promiscuous mode
- Any length (including less than 64 bytes and greater than RX_MAXLEN bytes)
- Was dropped on port 0 due to a lack of memory space in the receive FIFO.

Note

This statistic should be zero if proper flow control is being followed.

Host port 0

This statistic also counts frames dropped on port 0 that were 17 to 63 bytes (only for port 0). For Ethernet ports, the drop count for frames shorter than 33 bytes is included in the undersized or fragment count. Port 0 simply gives an indication that a packet was dropped. No other statistics are counted for frames shorter than 33 bytes.

13.2.1.4.6.17.1.16 Portmask Drop (Offset = 3A088h)

All ports

The total number of frames received on a port that were dropped by the ALE (the ALE did not forward the packet to any port). Port mask drop frame is defined to be:

- Any data or MAC control frame
- Any length greater than 32 bytes
- Was dropped by the ALE due to PORT_MASK=0 (was not sent to any destination port)
- Was not a long or error packet with the port in cut-thru mode
- The frame could have been dropped due to error or other counted reason, so it could be counted elsewhere also.

Note

This statistic does not count in the overall total as it includes every packet received greater than 32 bytes that had a zero PORT_MASK.

13.2.1.4.6.17.1.17 Rx Top of FIFO Drop (Offset = 3A08Ch)

All ports

The total number of frames received on a port that had a start-of-frame (SOF) overrun on any destination port egress (when attempting to load the packet from the top of the ingress port receive FIFO into any other port's transmit FIFO). If a multicast/broadcast packet is dropped by multiple destination ports then this statistic will increment by the number of ports that dropped the packet. Rx Top Of FIFO Drop is defined to be:

- Any data or MAC control frame which matched a unicast, broadcast or multicast address, or matched due to promiscuous mode
- Any length (including less than 64 bytes and greater than RX_MAXLEN bytes)
- had no CRC error, alignment error or code error
- had a SOF of frame overrun on another port egress.

13.2.1.4.6.17.1.18 ALE Rate Limit Drop (Offset = 3A090h)

All ports

The total number of frames received on a port that were dropped (zero PORT_MASK) due to receive rate limiting on this port or due to transmit rate limiting on any destination port (not sent to all expected destination ports if transmit rate limiting).

- Any data or MAC control frame which matched a unicast, broadcast or multicast address, or matched due to promiscuous mode
- Any length (including less than 64 bytes and greater than RX_MAXLEN bytes)
- had no CRC error, alignment error, or code error
- the receive rate was exceeded and the packet was dropped, or the transmit rate was exceeded to any destination port and the packet was dropped to one or more expected destination ports (indicates that the destinations were reduced due to rate limiting).

13.2.1.4.6.17.1.19 ALE VLAN Ingress Check Drop (Offset = 3A094h)

All ports

The total number of frames received on a port that were dropped (zero PORT_MASK) due to VLAN ingress check failure.

- Any data or MAC control frame which matched a unicast, broadcast or multicast address, or matched due to promiscuous mode

- Any length (including less than 64 bytes and greater than RX_MAXLEN bytes)
- had no CRC error, alignment error, or code error
- the VLAN ID ingress check failed (the receive port was not in the group)
- The address lookup did not return a match with the SUPER bit set.

2.1.4.6.17.1.19.1 ALE DA=SA Drop (Offset = 3A098h)

All ports

The total number of frames received on a port that were dropped (zero PORT_MASK) due to destination address equal to source address.

- Any data or MAC control frame which matched a unicast, broadcast or multicast address, or matched due to promiscuous mode
- Any length (including less than 64 bytes and greater than RX_MAXLEN bytes)
- had no CRC error, alignment error, or code error
- the destination address was equal to the source address
- the source address was not an entry in the table.

2.1.4.6.17.1.19.2 Block Address Drop (Offset = 3A09Ch)

The total number of frames received on a port that were dropped (zero PORT_MASK) due to the destination or source address being blocked.

- was any data or MAC control frame which matched a unicast, broadcast or multicast address, or matched due to promiscuous mode, and
- Any length (including less than 64 bytes and greater than RX_MAXLEN bytes)
- had no CRC error, alignment error, or code error, and
- the source or destination address matched a table entry with the block bit set.

2.1.4.6.17.1.19.3 ALE Secure Drop (Offset = 3A0A0h)

The total number of frames received on a port that were dropped (zero port_mask) due to a secure violation (the source address is owned by a different receive port).

- was any data or MAC control frame which matched a unicast, broadcast or multicast address, or matched due to promiscuous mode, and
- Any length (including less than 64 bytes and greater than RX_MAXLEN bytes)
- had no CRC error, alignment error, or code error, and
- the source address is an entry in the table with the SECURE bit set and a port number for a different receive port.

2.1.4.6.17.1.19.4 ALE Authentication Drop (Offset = 3A0A4h)

The total number of frames received on a port that were dropped (zero port_mask) due to authentication failure.

- was any data or MAC control frame which matched a unicast, broadcast or multicast address, or matched due to promiscuous mode, and
- Any length (including less than 64 bytes and greater than RX_MAXLEN bytes)
- had no CRC error, alignment error, or code error, and
- CPSW_ALE_CONTROL[1] ENABLE_AUTH_MODE is set to 1h, and
- the source address is not equal to the destination address, and
- the source address is not a table entry, and
- the destination address is not a table entry with the SUPER bit set.

2.1.4.6.17.1.19.5 ALE Unknown Unicast (Offset = 3A0A8h)

All ports

The total number of frames received on a port that had a unicast destination address with an unknown source address.

- was any data frame with a unicast destination address
- the source address was not a table entry

- was of length 64 to RX_MAXLEN bytes inclusive
- had no CRC error, alignment error, or code error

Note: The ALE Unknown Unicast Bytecount statistic is the number of bytes contained in the ALE Unknown Unicast frames.

2.1.4.6.17.1.19.6 ALE Unknown Unicast Bytecount (Offset = 3A0ACh)

The total number of bytes received on a port that had a unicast destination address with an unknown source address.

2.1.4.6.17.1.19.7 ALE Unknown Multicast (Offset = 3A0B0h)

The total number of frames received on a port that had a multicast destination address with an unknown source address. The frame is defined to be:

- was any data frame with a unicast destination address
- the source address was not a table entry, and
- was of length 64 to RX_MAXLEN bytes inclusive
- had no CRC error, alignment error or code error

Note: The ALE Unknown Multicast Bytecount statistic is the number of bytes contained in the ALE Unknown Multicast frames.

2.1.4.6.17.1.19.8 ALE Unknown Multicast Bytecount (Offset = 3A0B4h)

The total number of bytes received on a port that had a multicast destination address with an unknown source address.

2.1.4.6.17.1.19.9 ALE Unknown Broadcast (Offset = 3A0B8h)

The total number of frames received on a port that had a broadcast destination address with an unknown source address. The frame is defined to be:

- was any data frame with a unicast destination address
- the source address was not a table entry, and
- was of length 64 to RX_MAXLEN bytes inclusive
- had no CRC error, alignment error or code error

Note: The ALE Unknown Broadcast Bytecount statistic is the number of bytes contained in the ALE Unknown Broadcast frames.

2.1.4.6.17.1.19.10 ALE Unknown Broadcast Bytecount (Offset = 3A0BCh)

The total number of bytes received on a port that had a broadcast destination address with an unknown source address.

2.1.4.6.17.1.19.11 ALE Policer/Classifier Match (Offset = 3A0C0h)

All ports

The total number of frames received on a port that matched a policer. The frame is defined to be:

- was any data frame
- matched a condition on a policer,
- was of length 64 to RX_MAXLEN bytes inclusive
- had no CRC error, alignment error, or code error

2.1.4.6.17.1.19.12 ALE Policer Match Red (Offset = 3A0C4h)

The total number of frames received on a port that had matched a policer and the condition was red. The frame is defined to be:

- was any data frame
- matched a condition on a policer,
- was of length 64 to RX_MAXLEN bytes inclusive

- had no CRC error, alignment error, or code error

2.1.4.6.17.1.19.13 ALE Policer Match Yellow (Offset = 3A0C8h)

The total number of frames received on a port that had matched a policer and the condition was red. The frame is defined to be:

- was any data frame
- matched a condition on a policer,
- was of length 64 to RX_MAXLEN bytes inclusive
- had no CRC error, alignment error, or code error

13.2.1.4.6.17.2 Tx-only Statistics Descriptions

The maximum and minimum transmit frame size is software controllable.

13.2.1.4.6.17.2.1 Good Tx Frames (Offset = 3A034h)

All ports

The total number of good frames received on the port. A good frame is defined to be:

- Any data or MAC control frame which matched a unicast, broadcast or multicast address, or matched due to promiscuous mode
- Any length
- Had no late or excessive collisions, no carrier loss and no underrun

Note

A nonzero CPSW_STATN_TXDEFERREDFRAMES_k value should be subtracted from this value to obtain the actual good frames value (the good frames statistic also increments on a transmitted CRC error).

13.2.1.4.6.17.2.2 Broadcast Tx Frames (Offset = 3A038h)

All ports

The total number of good broadcast frames transmitted on the port. A good broadcast frame is defined to be:

- Any data or MAC control frame which was destined for only address FF.FF.FF.FF.FF.FF
- Any length
- Had no late or excessive collisions, no carrier loss and no underrun

13.2.1.4.6.17.2.3 Multicast Tx Frames (Offset = 3A03Ch)

All ports

The total number of good multicast frames transmitted on the port. A good multicast frame is defined to be:

- Any data or MAC control frame which was destined for any multicast address other than FF.FF.FF.FF.FF.FF
- Any length
- Had no late or excessive collisions, no carrier loss and no underrun

13.2.1.4.6.17.2.4 Pause Tx Frames (Offset = 3A040h)

Ethernet port N where N = 1 to 2

This statistic indicates the number of IEEE 802.3X pause frames transmitted by the port.

Pause frames cannot contain a CRC error because they are created in the transmitting MAC, so these error conditions have no effect upon the statistic. Pause frames sent by software will not be included in this count.

Since pause frames are only transmitted in full duplex, carrier loss and collisions have no effect upon this statistic.

Transmitted pause frames are always 64-byte multicast frames so will appear in the *Tx Multicast Frames* and *64octet Frames* statistics.

13.2.1.4.6.17.2.5 Deferred Tx Frames (Offset = 3A044h)
Ethernet port N where N = 1 to 2

The total number of frames transmitted on the port that first experienced deferment. Such a frame:

- Was any data or MAC control frame destined for any unicast, broadcast or multicast address
- Was any size
- Had no carrier loss and no underrun
- Experienced no collisions before being successfully transmitted
- Found the medium busy when transmission was first attempted, so had to wait.

CRC errors have no effect upon this statistic.

13.2.1.4.6.17.2.6 Collisions (Offset = 3A048h)
Ethernet port N where N = 1 to 2

This statistic records the total number of times that the port experienced a collision. Collisions occur under two circumstances.

1. When a transmit data or MAC control frame:
 - Was destined for any unicast, broadcast or multicast address
 - Was any size
 - Had no carrier loss and no underrun
 - Experienced a collision. A jam sequence is sent for every non-late collision, so this statistic will increment on each occasion if a frame experiences multiple collisions (and increments on late collisions)

CRC errors have no effect upon this statistic.
2. When the port is in half-duplex mode, flow control is active, and a frame reception begins.

13.2.1.4.6.17.2.7 Single Collision Tx Frames (Offset = 3A04Ch)
Ethernet port N where N = 1 to 2

The total number of frames transmitted on the port that experienced exactly one collision. Such a frame:

- Was any data or MAC control frame destined for any unicast, broadcast or multicast address
- Was any size
- Had no carrier loss and no underrun
- Experienced one collision before successful transmission. The collision was not late.

CRC errors have no effect upon this statistic.

13.2.1.4.6.17.2.8 Multiple Collision Tx Frames (Offset = 3A050h)
Ethernet port N where N = 1 to 2

The total number of frames transmitted on the port that experienced multiple collisions. Such a frame:

- Was any data or MAC control frame destined for any unicast, broadcast or multicast address
- Was any size
- Had no carrier loss and no underrun
- Experienced 2 to 15 collisions before being successfully transmitted. None of the collisions were late.

CRC errors have no effect upon this statistic.

13.2.1.4.6.17.2.9 Excessive Collisions (Offset = 3A054h)
Ethernet port N where N = 1 to 2

The total number of frames for which transmission was abandoned due to excessive collisions. Such a frame:

- Was any data or MAC control frame destined for any unicast, broadcast or multicast address
- Was any size
- Had no carrier loss and no underrun

- Experienced 16 collisions before abandoning all attempts at transmitting the frame. None of the collisions were late.

CRC errors have no effect upon this statistic.

13.2.1.4.6.17.2.10 Late Collisions (Offset = 3A058h)

Ethernet port N where N = 1 to 2

The total number of frames on the port for which transmission was abandoned because they experienced a late collision. Such a frame:

- Was any data or MAC control frame destined for any unicast, broadcast or multicast address
- Was any size
- Experienced a collision later than 512 bit-times into the transmission. There may have been up to 15 previous (non-late) collisions which had previously required the transmission to be re-attempted. The *Late Collisions* statistic dominates over the single-, multiple-, and excessive- collision statistics. If a late collision occurs, the frame will not be counted in any of these other three statistics.

CRC errors have no effect upon this statistic.

13.2.1.4.6.17.2.11 Carrier Sense Errors (Offset = 3A060h)

Ethernet port N where N = 1 to 2

The total number of frames on the port that experienced carrier loss. Such a frame:

- Was any data or MAC control frame destined for any unicast, broadcast or multicast address
- Was any size
- The carrier sense condition was lost or never asserted when transmitting the frame (the frame is not retransmitted). This is a transmit only statistic. Carrier Sense is a don't care for received frames. Transmit frames with carrier sense errors are sent until completion and are not aborted.

CRC errors have no effect upon this statistic.

13.2.1.4.6.17.2.12 Tx Octets (Offset = 3A064h)

All ports

The total number of bytes in all good frames transmitted on the port. A good frame is defined to be:

- Any data or MAC control frame which was destined for any unicast, broadcast or multicast address
- Was any size
- Had no late or excessive collisions, no carrier loss and no underrun.

13.2.1.4.6.17.2.13 Transmit Priority 0-7 (Offset = 3A180h to 3A1A8h)

The total number of frames transmitted on the port from transmit FIFO priority 0-7. Collision retries do not affect this statistic. Pause frames do not affect this statistic.

- Any frame transmitted from priority 0-7, and
- Was less than or equal to CPSW_TX_PRI0_MAXLEN_REG to CPSW_TX_PRI7_MAXLEN_REG
- Collision retries are not counted in this statistic.
- Pause frames are not counted in this statistic.
- Carrier sense errors do not affect this statistic.

Note: The Transmit Priority 0-7 Bytecount statistic is the number of bytes contained in the frames of the Transmit Priority 0-7 statistic.

13.2.1.4.6.17.2.14 Transmit Priority 0-7 Drop (Offset = 3A1C0h to 3A1E8)

The total number of transmit frames on the port that overran the transmit FIFO priority 0-7 and were dropped. This count includes frames dropped due to CPSW_TX_PRI0_MAXLEN_REG to CPSW_TX_PRI7_MAXLEN_REG.

- Any frame destined to be transmitted from priority 0-7, and

- Was any size, and
- Was dropped due to priority 0-7 FIFO overrun (Start of packet overrun).
- Was dropped due to frame size larger than CPSW_TX_PRI0_MAXLEN_REG to CPSW_TX_PRI7_MAXLEN_REG.

Note: The Transmit Priority 0-7 Drop Bytecount statistic is the number of bytes contained in the frames of the Transmit Priority 0-7 Drop statistic.

13.2.1.4.6.17.2.15 Tx Memory Protect Errors (Offset = 3A17Ch)

All ports

The total number of transmit frames on the port that had a memory protect CRC error on egress:

- Any frame destined to be transmitted,
- Was any size
- Had a memory protect CRC error on egress.

Note

1. Frames to the host with memory protect errors are dropped via TXST_DROP. Ethernet frames will have at least one byte of the generated port type CRC inverted on egress.
 2. This statistic is 8-bits wide only and will not rollover but will limit at 0xFF.
 3. A non-zero value in this statistic will issue a STAT_PEND0 interrupt for the associated port.
-

13.2.1.4.6.17.2.16 Tx CRC Errors

The total number of frames transmitted on the port with a CRC error. Such a frame:

- was any data frame destined for any unicast, broadcast or multicast address, and
- was any size, and
- was sent cut-thru by the receive port and was received with a CRC error, or
- was a transmitted frame that also had a memory protect error (counted also in CPSW_STATN_TX_MEMORY_PROTECT_ERROR_k).

Note

For port0 this statistics location (CPSW_STAT0_TXDROP) counts the number of drops to the host due to a memory protect error, or due to a cut-thru packet having an error on reception but was forwarded with the error. The Ethernet port receive error could be long, CRC, jabber, or code. For Ethernet ports, the receive error could be the same but the packet is transmitted with at least one byte of the actual outgoing packet CRC inverted to indicate the error.

Note

A nonzero CPSW_STATN_TXDEFERREDFRAMES_k value should be subtracted from the CPSW_STATN_TXGOODFRAMES_k value to obtain the actual good frames value (the good frames statistic also increments on a transmitted CRC error).

13.2.1.4.6.17.3 Rx- and Tx (Shared) Statistics Descriptions

13.2.1.4.6.17.3.1 Rx + Tx 64 Octet Frames (Offset = 3A068h)

All ports

The total number of 64-byte frames received and transmitted on the port. Such a frame is defined to be:

- Any data or MAC control frame which was destined for any unicast, broadcast or multicast address
- Did not experience late collisions, excessive collisions, or carrier sense error
- Was exactly 64 bytes long. (If the frame was being transmitted and experienced carrier loss that resulted in a frame of this size being transmitted, then the frame will be recorded in this statistic).

CRC errors, code/align errors and overruns do not affect the recording of frames in this statistic.

13.2.1.4.6.17.3.2 Rx + Tx 65–127 Octet Frames (Offset = 3A06Ch)

All ports

The total number of frames of size 65 to 127 bytes received and transmitted on the port. Such a frame is defined to be:

- Any data or MAC control frame which was destined for any unicast, broadcast or multicast address
- Did not experience late collisions, excessive collisions, or carrier sense error
- Was 65 to 127 bytes long

CRC errors, code/align errors, underruns and overruns do not affect the recording of frames in this statistic.

13.2.1.4.6.17.3.3 Rx + Tx 128–255 Octet Frames (Offset = 3A070h)

All ports

The total number of frames of size 128 to 255 bytes received and transmitted on the port. Such a frame is defined to be:

- Any data or MAC control frame which was destined for any unicast, broadcast or multicast address
- Did not experience late collisions, excessive collisions, or carrier sense error
- Was 128 to 255 bytes long

CRC errors, code/align errors, underruns and overruns do not affect the recording of frames in this statistic.

13.2.1.4.6.17.3.4 Rx + Tx 256–511 Octet Frames (Offset = 3A074h)

All ports

The total number of frames of size 256 to 511 bytes received and transmitted on the port. Such a frame is defined to be:

- Any data or MAC control frame which was destined for any unicast, broadcast or multicast address
- Did not experience late collisions, excessive collisions, or carrier sense error
- Was 256 to 511 bytes long

CRC errors, code/align errors, underruns and overruns do not affect the recording of frames in this statistic.

13.2.1.4.6.17.3.5 Rx + Tx 512–1023 Octet Frames (Offset = 3A078h)

All ports

The total number of frames of size 512 to 1023 bytes received and transmitted on the port. Such a frame is defined to be:

- Any data or MAC control frame which was destined for any unicast, broadcast or multicast address
- Did not experience late collisions, excessive collisions, or carrier sense error
- Was 512 to 1023 bytes long

CRC errors, code/align errors, underruns and overruns do not affect the recording of frames in this statistic.

13.2.1.4.6.17.3.6 Rx + Tx 1024_Up Octet Frames (Offset = 3A07Ch)

All ports

The total number of frames of size 1024 to RX_MAXLEN bytes for receive or 1024 up for transmit on the port. Such a frame is defined to be:

- Any data or MAC control frame which was destined for any unicast, broadcast or multicast address
- Did not experience late collisions, excessive collisions, or carrier sense error
- Was 1024 to RX_MAXLEN bytes long on receive, or any size on transmit

CRC errors, code/align errors, underruns and overruns do not affect the recording of frames in this statistic.

13.2.1.4.6.17.3.7 Net Octets (Offset = 3A080h)

All ports

The total number of bytes of frame data received and transmitted on the port. Each frame counted:

- was any data or MAC control frame destined for any unicast, broadcast or multicast address (address match does not matter)
- Any length (including less than 64 bytes and greater than RX_MAXLEN bytes)

Also counted in this statistic is:

- Every byte transmitted before a carrier-loss was experienced
- Every byte transmitted before each collision was experienced, (that is, multiple retries are counted each time)
- Every byte received if the port is in half-duplex mode until a jam sequence was transmitted to initiate flow control. (The jam sequence was not counted to prevent double-counting)

Error conditions such as alignment errors, CRC errors, code errors, overruns and underruns do not affect the recording of bytes by this statistic.

The objective of this statistic is to give a reasonable indication of Ethernet utilization.

13.2.1.4.6.17.4

Table 13-149. Rx Statistics Summary

Rx Statistic	Frame Type		MAC control					Data ⁽⁵⁾							Frame Size (bytes)					Event				
			Pause frame	Non-pause ⁽⁴⁾	Multi-cast	Broad-cast	Uni-cast	<64	64	65-127	128-255	256-511	512-1023	1024 - rx_maxlen	>rx_maxlen	Flow Coll. ⁽⁸⁾	CRC Error	Align/Code	Overrun	Addr. Disc.				
Good Rx Frames	F	Rx	(y) ⁽¹⁾	y	y	y	y	y)	n	(y	y	y	y	y	y)	n	-. ⁽²⁾	n	n	-	n			
Broadcast Rx Frames	F	Rx	(% ⁽⁶⁾	%	n	y)	n	n	n	(y	y	y	y	y	y)	n	-	n	n	-	n			
Multicast Rx Frames	F	Rx	(%	%	y)	n	n	n	n	(y	y	y	y	y	y)	n	-	n	n	-	n			
Pause Rx Frames	F	Rx	y	n	n	n	n	n	n	(y	y	y	y	y	y)	n	-	n	n	-	-			
Rx CRC Errors	F	Rx	(y	y	y	y	y)	n	(y	y	y	y	y	y	y)	n	-	y	n	-	n			
Rx Align/Code Errors	F	Rx	(y	y	y	y	y)	n	(y	y	y	y	y	y	y)	n	-	-	y	-	n			
Oversized Rx Frames	F	Rx	(y	y	y	y	y)	n	n	n	n	n	n	n	y	-	n	n	-	n				
Rx Jabbers	F	Rx	(y	y	y	y	y)	n	n	n	n	n	n	y	-	(y	y)	-	n					
Undersized Rx Frames	F	Rx	n	n	(y	y	y)	y	n	n	n	n	n	n	n	-	n	n	-	n				
Rx Fragments	F	Rx	n	n	(y	y	y)	y ⁽⁷⁾	n	n	n	n	n	n	n	-	(y	y)	-	-				
Rx Overruns ⁽⁹⁾	F	Rx	(y	y	y	y	y)	(y	y	y	y	y	y	y	y)	-	-	-	y	n				
64octet Frames	F	Rx+Tx ⁽³⁾	(y	y	y	y	y)	n	y	n	n	n	n	n	n	-	-	-	-	n				
65-127octet Frames	F	Rx+Tx	(y	y	y	y	y)	n	n	y	n	n	n	n	n	-	-	-	-	n				
128-255octet Frames	F	Rx+Tx	(y	y	y	y	y)	n	n	n	y	n	n	n	n	-	-	-	-	n				
256-511octet Frames	F	Rx+Tx	(y	y	y	y	y)	n	n	n	n	y	n	n	n	-	-	-	-	n				

Table 13-149. Rx Statistics Summary (continued)

Rx Statistic	Frame/ Oct	Rx/ Rx+ Tx	Frame Type					Frame Size (bytes)							Event					
			MAC control		Data ⁽⁵⁾			<64	64	65-127	128-255	256-511	512-1023	1024 - rx_max len	>rx_max len	Flow Coll. (8)	CRC Error	Align/ Code	Overrun	Addr. Disc.
			Pause frame	Non-pause ⁽⁴⁾	Multicast	Broadcast	Unicast													
512-1023octet Frames	F	Rx+ Tx	(y	y	y	y	y	n	n	n	n	n	y	n	n	-	-	-	-	n
1024-UPoctet Frames	F	Rx+ Tx	(y	y	y	y	y	n	n	n	n	n	n	y	n	-	-	-	-	n
Rx Octets	O	Rx	(y	y	y	y	y	n	(y	y	y	y	y	y)	n	-	n	n	-	n
Net Octets	O	Rx+ Tx	(y	y	y	y	y	(y	y	y	y	y	y	y	y	y)	-	-	-	-

- (1) "AND" is assumed horizontally across the table between all conditions which form the statistic (marked y or n) except where (y|y), meaning "OR" is indicated. Parentheses are significant.
- (2) "-" indicates conditions which are ignored in the formations of the statistic.
- (3) Statistics marked "Rx+Tx" are formed by summing the Rx and Tx statistics, each of which is formed independently.
- (4) The non-pause column refers to all MAC control frames (for example, frames with length/type=88.08) with opcodes other than 0x0001. The pauseframe column refers to MAC frames with the opcode=0x0001.
- (5) The multicast, broadcast and unicast columns in the table refer to non-MAC Control/non-pause frames (i.e. data frames).
- (6) "%" If either a MAC control frame or pause frame has a multicast or broadcast destination address then the appropriate statistics will be updated.
- (7) "y^" Frame fragments are not counted if less than 8 bytes.
- (8) Flow coll. are half-duplex collisions forced by the MAC to achieve flow-control. A collision will be forced during the first 8 bytes so should not show in frame fragments. Some of the '-'s in this column might in reality be 'n's.
- (9) The rx_overruns stat is for RX_MOF_OVERRUNS and RX_SOF_OVERRUNS added together.

Table 13-150. Tx Statistics Summary

Tx Statistic ⁽⁹⁾	Frame/ Oct	Tx/ Rx+ Tx	Frame Type					Frame Size (bytes)										Event							
			MAC control ⁽⁴⁾		Data			64	65-127	128-255	256-511	512-1023	1024-4095	4096-16383	>16383	CRC Error	Collision Type				No Carrier	Queue	Deferred	Underrun	
			Pause-MA C	Any-CP U	Multicast	Broadcast	Unicast										Floww ⁽⁸⁾	1	2-15	16					Late
Good Tx Frames	F	Tx	(y ⁽¹⁾	y	y	y	y	(y	y	y	y	y	y	y	y	-. ⁽²⁾	-	-	-	n	n	n	-	-	n
Broadcast Tx Frames	F	Tx	n	(% ⁽⁵⁾	n	y)	n	(y	y	y	y	y	y	y	y)	-	-	-	-	n	n	n	-	-	n
Multicast Tx Frames	F	Tx	(y	%	y)	n	n	(y	y	y	y	y	y	y)	-	-	-	-	n	n	n	-	-	n	
Pause Tx Frames	F	Tx	y	n	n	n	n	y	n	n	n	n	n	n	-	-	-	-	-	-	-	-	-	-	-
Collisions	F	Tx	n	(y	y	y	y	(y	y	y	y	y	y	y)	-	(+ ⁽⁶⁾	+	+	+	+	n	-	-	-	
Single Collision Tx Frames	F	Tx	n	(y	y	y	y	(y	y	y	y	y	y	y)	-	-	y	n	n	n	n	-	-	-	
Multiple Collision Tx Frames	F	Tx	n	(y	y	y	y	(y	y	y	y	y	y	y)	-	-	n	y	n	n	n	-	-	-	
Excessive Collisions	F	Tx	n	(y	y	y	y	(y	y	y	y	y	y	y)	-	-	n	n	y	n	n	-	-	-	
Late Collisions	F	Tx	n	(y	y	y	y	n	(y	y	y	y	y	y)	-	-	-	-	-	y	-	-	-	-	

ADVANCE INFORMATION

Table 13-150. Tx Statistics Summary (continued)

Tx Statistic ⁽⁹⁾	Frame Type		Frame Size (bytes)											Event											
			MAC control ⁽⁴⁾				Data							Collision Type				No Car rier	Qu eue d	Def err ed	Un der run				
			Pau se- MA C	An y- CP U	Mul ti- cas t	Bro ad- cas t	Uni cas t	64	65- 127	128 -25 5	256 -51 1	512 -10 23	102 4-1 535	>15 35	CR C Err or	Flo w ⁽⁸⁾	1					2-1 5	16	Lat e	
Deferred Tx Frames	F	Tx	n	(y)	(y)	(y)	(y)	(y)	(y)	(y)	(y)	(y)	(y)	(y)	(y)	-	-	n	n	n	n	n	-	y	n
Carrier Sense Errors	F	Tx	(y)	(y)	(y)	(y)	(y)	(y)	(y)	(y)	(y)	(y)	(y)	(y)	(y)	-	-	-	-	-	-	y	-	-	-
64octet Frames	F	Rx+ Tx ⁽³⁾	(y)	(y)	(y)	(y)	(y)	y	n	n	n	n	n	n	n	-	-	-	-	n	n	n	-	-	-
65-127octet Frames	F	Rx+ Tx	(y)	(y)	(y)	(y)	(y)	n	y	n	n	n	n	n	n	-	-	-	-	n	n	n	-	-	-
128-255octet Frames	F	Rx+ Tx	(y)	(y)	(y)	(y)	(y)	n	n	y	n	n	n	n	n	-	-	-	-	n	n	n	-	-	-
256-511octet Frames	F	Rx+ Tx	(y)	(y)	(y)	(y)	(y)	n	n	n	y	n	n	n	n	-	-	-	-	n	n	n	-	-	-
512-1023octet Frames	F	Rx+ Tx	(y)	(y)	(y)	(y)	(y)	n	n	n	n	y	n	n	n	-	-	-	-	n	n	n	-	-	-
1024-UPoctet Frames	F	Rx+ Tx	(y)	(y)	(y)	(y)	(y)	n	n	n	n	n	y	y	y	-	-	-	-	n	n	n	-	-	-
Tx Octets	O	Tx	(y)	(y)	(y)	(y)	(y)	(y)	(y)	(y)	(y)	(y)	(y)	(y)	(y)	-	-	-	-	n	n	n	-	-	n
Net Octets	O	Rx+ Tx	(y)	(y)	(y)	(y)	(y)	(y)	(y)	(y)	(y)	(y)	(y)	(y)	(y)	-	-	\$ ⁽⁷⁾	\$	\$	\$	\$	-	-	-

- (1) "AND" is assumed horizontally across the table between all conditions which form the statistic (marked y or n) except where (y|y), meaning "OR" is indicated. Parentheses are significant.
- (2) "-" indicates conditions which are ignored in the formations of the statistic.
- (3) Statistics marked "Rx+Tx" are formed by summing the Rx and Tx statistics, each of which is formed independently.
- (4) Pause (MAC) frames are issued in the MAC as perfect (no CRC error) 64 byte frames in full duplex only, so they cannot collide.
- (5) "%" If a CPU sourced MAC control frame has a multicast or broadcast destination address then the appropriate statistics will be updated.
- (6) "+" indicates collisions which are "summed" (i.e. every collision is counted in the Collisions statistic). Jam sequences used for halfduplex flow control are also counted.
- (7) "\$" Every byte written on the wire during each retry attempt is also counted in addition to frames which experience no collisions or carrier loss.
- (8) The flow collision type is for half-duplex collisions forced by the MAC to achieve flow control. Some of the '-'s in this column might in reality be 'n's. To prevent double-counting, Net Octets are unaffected by the jam sequence – the 'received' bytes, however, are counted. (See [Table 13-149](#).)
- (9) When the transmit Tx FIFO is drained due to the MAC being disabled or link being lost, then the frames being purged will not appear in the Tx statistics.

13.2.1.4.7 Common Platform Time Sync (CPTS)

The Common Platform Time Sync (CPTS) module is used to facilitate host control of time sync operations. It enables compliance with the IEEE 1588-2008 standard for a precision clock synchronization protocol.

Main features of CPTS module are:

- Supports the selection of multiple external clock sources
- Software control of time sync events via interrupt or polling
- Supports up to 8 hardware timestamp push inputs
- Supports timestamp counter compare output (CPTS_COMP)

- Supports timestamp counter bit output (CPTS_SYNC)
- Supports a configurable number of timestamp Generator bit outputs (CPTS_GENFn).
- Supports Ethernet Enhanced Scheduled Traffic Operations (CPTS_ESTFn).
- 32-bit and 64-bit timestamp modes with PPM and nudge adjustment.

13.2.1.4.7.1 CPTS Architecture

Figure 13-106 shows the architecture of the CPTS module inside the CPSW Ethernet Subsystem. Time stamp values for every packet transmitted or received on external port of the CPSW are recorded. At the same time, each packet is decoded to determine if it is a valid time sync event. If so, an event is loaded into the Event FIFO for processing containing the recorded time stamp value when the packet was transmitted or received.

In addition, both hardware (HWn_TS_PUSH) and software (TS_PUSH) can be used to read the current time stamp value though the Event FIFO. The reference clock used for the time stamp (CPTS_RFT_CLK) can be derived from several sources.

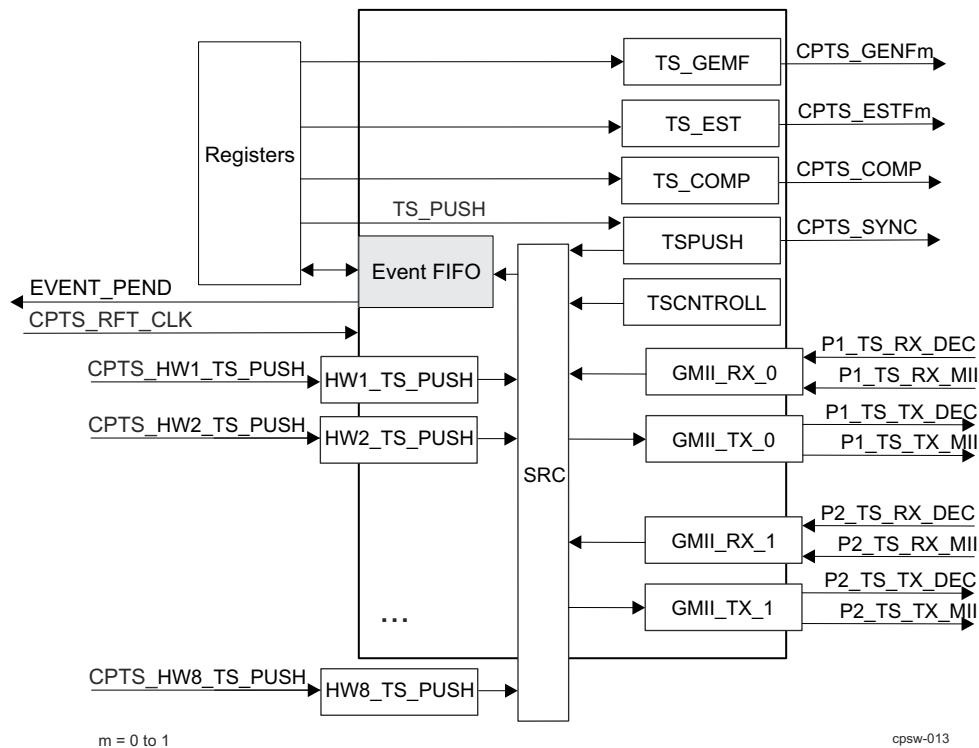

Figure 13-106. CPTS Block Diagram

Note

See *CPSW0 CPTS Integration* for CPTS integration in the device CPSW0 module.

13.2.1.4.7.2 CPTS Initialization

The CPTS module should be configured as follows:

1. Reset the CPTS module.
2. Write the CPTS_CLKSEL value in the CTRLMMR_CPTS_CLKSEL register with the desired reference clock selection. This value is allowed to be written only when the CPTS_EN bit in the CPSW_CPTS_CONTROL_REG register is cleared to zero.
3. Set the CPTS_EN bit in the CPSW_CPTS_CONTROL_REG register.
4. If using interrupts and not polling, enable the interrupt by setting the TS_PEND_EN bit in the CPSW_CPTS_INT_ENABLE_REG register.

13.2.1.4.7.3 32-bit Time Stamp Value

The time stamp value is a 32-bit value that increments on each CPTS_RFT_CLK rising edge when CPTS_EN bit is set to 1h. When CPTS_EN bit is cleared to 0h, the time stamp value is reset to 0h.

If more than 32-bits of time stamp are required by the application, the host software must maintain the necessary number of upper bits. The upper time stamp value should be incremented by the host when the rollover event is detected.

For test purposes, the time stamp can be written via the time stamp load function (CPSW_CPTS_TS_LOAD_VAL_REG / CPSW_CPTS_TS_LOAD_HIGH_VAL_REG and CPSW_CPTS_TS_LOAD_EN_REG registers).

13.2.1.4.7.4 64-bit Time Stamp Value

The time stamp value is a 64-bit value that increments on each CPTS_RFT_CLK rising edge when CPTS_EN bit is set to 1h. When CPTS_EN bit is cleared to 0h, the time stamp value is reset to 0h.

64-bit mode is selected when CPSW_CPTS_CONTROL_REG[5] MODE bit set to 1h.

For test purposes, the time stamp value can be written via the time stamp load function (CPSW_CPTS_TS_LOAD_EN_REG, CPSW_CPTS_TS_LOAD_VAL_REG, and CPSW_CPTS_TS_LOAD_HIGH_VAL_REG registers). The CPSW_CPTS_TS_ADD_VAL_REG feature is included to allow 1ns timestamp operations with an CPTS_RFT_CLK rate less than 1Ghz. [Table 13-151](#) shows the CPTS_RFT_CLK and CPSW_CPTS_TS_ADD_VAL_REG values for 1ns operations.

Table 13-151. ADD_VAL feature

CPTS_RFT_CLK (MHz)	CPSW_CPTS_TS_ADD_VAL_REG[2-0] ADD_VAL
1 GHz	0
500 MHz	1
333.33 MHz	2
250 MHz	3
200 MHz	4
166.66 MHz	5
142.85714 MHz	6
125 MHz	7

13.2.1.4.7.5 64-Bit Timestamp Nudge

The 64-bit TIME_STAMP value can be adjusted by writing the CPSW_CPTS_TS_NUDGE_VAL_REG[7-0] TS_NUDGE_VAL bit field value which is a two's complement value. A value of FFh will subtract 1 clock cycle from the next incremented 64-bit time stamp value (CPSW_CPTS_EVENT_0_REG[31-0] TIME_STAMP and CPSW_CPTS_EVENT_3_REG[31-0] TIME_STAMP value). A nudge value of 1h will add 1 clock cycle to the next incremented TIME_STAMP[63-0] value. For example, if the current TIME_STAMP value is F06h, and CPSW_CPTS_TS_ADD_VAL_REG[2-0] ADD_VAL = 3h, the next incremented timestamp value would be F0Ah without a nudge and F0Ah +/- [7-0] TS_NUDGE_VAL with a nudge. The [7-0] TS_NUDGE_VAL value is cleared to zero when the nudge has occurred.

13.2.1.4.7.6 64-bit Timestamp PPM

The 64-bit TIME_STAMP can be adjusted by parts per million or by parts per hour. Writing a non-zero value to the CPSW_CPTS_TS_PPM_LOW_VAL_REG[31-0] TS_PPM_LOW_VAL (Time stamp PPM Low value) and CPSW_CPTS_TS_PPM_HIGH_VAL_REG[9-0] TS_PPM_HIGH_VAL (Time stamp PPM High value) enables PPM operations. The adjustment is up or down depending on the [7] TS_PPM_DIR bit in the CPSW_CPTS_CONTROL_REG register. The TIME_STAMP value is increased by the PPM value when [7] TS_PPM_DIR bit is cleared. The TIME_STAMP value is decreased by the PPM value when [7] TS_PPM_DIR bit is set.

Parts Per Million example:

To adjust for 100 parts per million the configured value for TS_PPM[41-0] (through CPSW_CPTS_TS_PPM_LOW_VAL_REG[31-0] TS_PPM_LOW_VAL and CPSW_CPTS_TS_PPM_HIGH_VAL_REG[9-0] TS_PPM_HIGH_VAL) is:
 $1,000,000/100 = 10,000(\text{decimal})$

Parts Per Hour example:

To adjust for 1 part per hour at 1 GHz CPTS_RFT_CLK the configured value for TS_PPM[41-0] (through CPSW_CPTS_TS_PPM_LOW_VAL_REG[31-0] TS_PPM_LOW_VAL and CPSW_CPTS_TS_PPM_HIGH_VAL_REG[9-0] TS_PPM_HIGH_VAL) is:
 $(1,000,000,000\text{Hz}/1\text{pph}) * (3600 \text{ seconds}/\text{hour}) = 34630\text{B8A}000 \text{ (hex)}$

13.2.1.4.7.7 Event FIFO

All time sync events are pushed onto the Event FIFO. There are 10 locations in the event FIFO with no overrun indication supported. Software must service the event FIFO in a timely manner to prevent FIFO overrun.

13.2.1.4.7.8 Timestamp Compare Output

CPTS features one Time Stamp Compare (CPTS_COMP) output. The CPTS_COMP function is a software oriented feature that is intended to be replaced going forward by the hardware oriented GENF function. CPTS_COMP is not compatible with timestamp PPM or a non-zero CPSW_CPTS_TS_ADD_VAL_REG[2-0] ADD_VAL value.

13.2.1.4.7.8.1 Non-Toggle Mode: 32-bit

The CPTS_COMP output is asserted for CPSW_CPTS_TS_COMP_LEN_REG[31-0] TS_COMP_LENGTH periods when the CPSW_CPTS_EVENT_0_REG[31-0] TIME_STAMP value (lowe 32-bits) compares with the CPSW_CPTS_TS_COMP_VAL_REG[31-0] TS_COMP_VAL and the length value is non-zero. The CPTS_COMP rising edge occurs three CPTS_RFT_CLK clock periods after the values compare. A timestamp compare event is pushed into the event FIFO when CPTS_COMP is asserted. The polarity of the CPTS_COMP output is determined by the CPSW_CPTS_CONTROL_REG[2] TS_COMP_POLARITY bit. The output is asserted low when the polarity bit is 0h.

13.2.1.4.7.8.2 Non-Toggle Mode: 64-bit

64-bit mode operation is identical to 32-bit mode except that all 64-bits of the TIME_STAMP are used (CPSW_CPTS_EVENT_0_REG and CPSW_CPTS_EVENT_3_REG). In 32-bit mode only the lower 32-bits (CPSW_CPTS_EVENT_0_REG) are used.

13.2.1.4.7.8.3 Toggle Mode: 32-bit

The CPTS_COMP output is asserted (CPSW_CPTS_TS_COMP_LEN_REG[31-0] TS_COMP_LENGTH) for CPTS_RFT_CLK clock periods when the TIME_STAMP[31:0] value compares with the CPSW_CPTS_TS_COMP_VAL_REG and the length value is non-zero. The CPTS_COMP toggles thereafter on CPSW_CPTS_TS_COMP_VAL_REG[31-0] TS_COMP_LENGTH for CPTS_RFT_CLK periods. The length high or low can be adjusted by writing the CPSW_CPTS_TS_COMP_NUDGE_REG[7-0] NUDGE bit field value which is a two's complement value. A value of FFh will subtract one CPTS_RFT_CLK period from the CPSW_CPTS_TS_COMP_VAL_REG[31-0] TS_COMP_LENGTH value. A value of 0x01h will add one CPTS_RFT_CLK period to the CPSW_CPTS_TS_COMP_LEN_REG[31-0] TS_COMP_LENGTH value. Only a single high or low time is adjusted (nudged) and the CPSW_CPTS_TS_COMP_NUDGE_REG[7-0] NUDGE value is cleared to zero when the nudge has occurred. The CPTS_COMP output is asserted low when the CPSW_CPTS_CONTROL_REG[2] TS_COMP_POLARITY bit is 0h. No compare events and no CPTS_EVNT interrupts are generated in toggle mode. The CPSW_CPTS_CONTROL_REG[6] TS_COMP_TOG bit must be set for toggle mode (value 1h). Note this bit must be set before writing a non-zero value to CPSW_CPTS_TS_COMP_VAL_REG register.

13.2.1.4.7.8.4 Toggle Mode: 64-bit

64-bit mode operation is identical to 32-bit mode except that all 64-bits of the TIMESTAMP are used (CPSW_CPTS_EVENT_0_REG and CPSW_CPTS_EVENT_3_REG). In 32-bit mode only the lower 32-bits (CPSW_CPTS_EVENT_0_REG) are used.

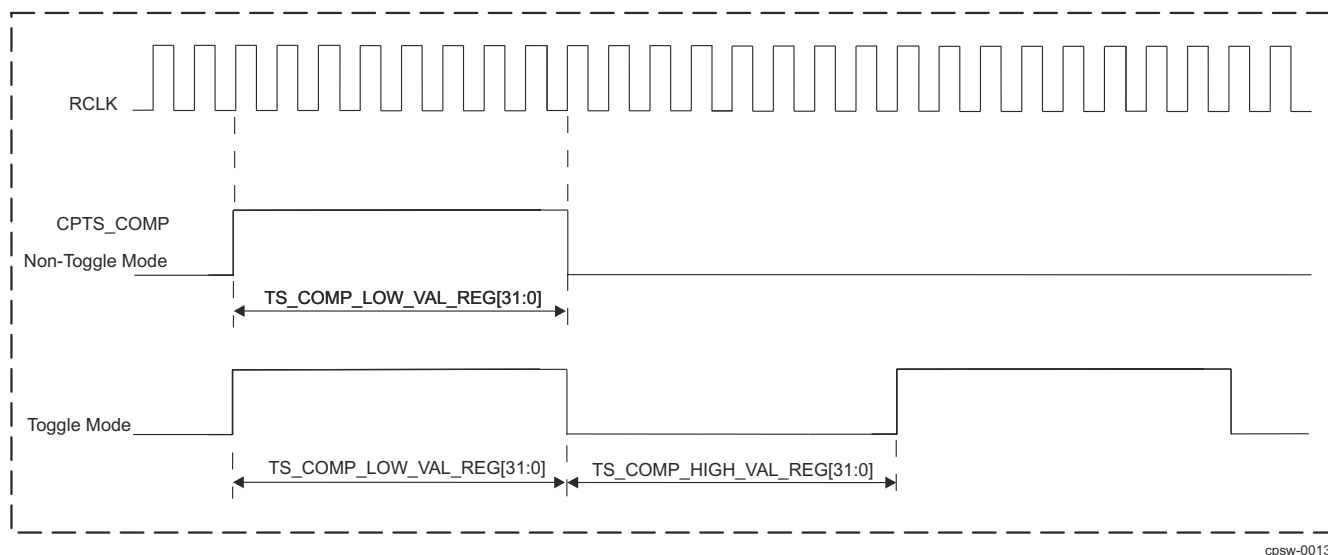

cpsw-0013a

Figure 13-107. CPTS_COMP Output in Toggle and Non-Toggle Mode

13.2.1.4.7.9 Timestamp Sync Output

The CPTS_SYNC output is a selected bit of the [31:0]TIME_STAMP counter value. One of bits 17-31 can be selected in CPSW_CPTS_CONTROL_REG[31:28] TS_SYNC_SEL. The CPTS_SYNC output is disabled when CPSW_CPTS_CONTROL_REG[31:28] TS_SYNC_SEL is zero.

If the selected counter bit is 1 at the time when TS_SYNC_SEL value is written then a rising edge will not occur on the CPTS_SYNC output. A rising edge will occur on the CPTS_SYNC output upon the next transition to 1 of the selected counter bit. The TS_SYNC_SEL value must be written to zero before changing to a different non-zero value. No events are generated due to the CPTS_SYNC operation. The CPTS_SYNC output is two CPTS_RFT_CLK periods after the actual count value.

13.2.1.4.7.10 Timestamp GENFn Output

The CPTS_GENFn outputs have a programmable cycle (frequency) with a PPM feature and software nudge feature. The CPTS_GENFn output cycle is CPSW_GENF0_LENGTH_REG_L[31:0] CPTS_RFT_CLK periods (which is different than CPTS_COMP operation). [Figure 13-108](#) represents the CPTS_GENFn output signal.

The CPTS_GENFn output cycle is CPSW_GENF0_LENGTH_REG_L[31:0] CPTS_RFT_CLK periods beginning when the 64-bit TIME_STAMP value compares with the 64-bit GENFn_COMP value (CPSW_GENF0_COMP_LOW_REG_L and CPSW_GENF0_COMP_HIGH_REG_L registers) and the length value is non-zero. The CPTS_GENFn output cycle repeats thereafter every CPSW_GENF0_LENGTH_REG_L[31:0] CPTS_RFT_CLK periods. The upper 32-bit word should be written first for 64-bit values. The length should be zero while the comparison value and other configuration parameters are being configured. The length should be written non-zero to enable operations last. The first cycle after comparison is active high when the CPSW_CPTS_CONTROL_REG[2] TS_COMP_POLARITY bit is low. No compare events and no CPTS_EVT interrupt are generated.

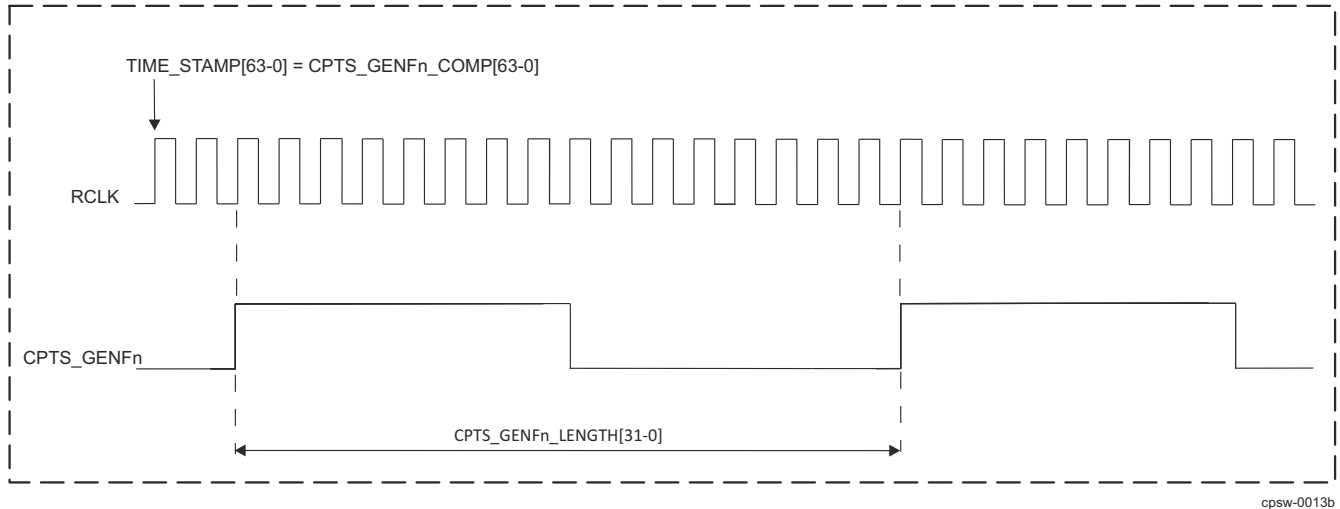

Figure 13-108. CPTS_GENFn Output Signal Diagram

13.2.1.4.7.10.1 GENFn Nudge

The cycle length can be adjusted by writing the CPSW_CPTS_TS_COMP_NUDGE_REG[7-0] NUDGE register value which is a two's complement value. A value of FFh will subtract 1 CPTS_RFT_CLK from the CPSW_GENF0_LENGTH_REG_L[31-0] value. A value of 1h will add 1 CPTS_RFT_CLK to the CPSW_GENF0_LENGTH_REG_L[31-0] value. The CPSW_CPTS_TS_COMP_NUDGE_REG[7-0] NUDGE value is cleared to zero when the nudge has occurred.

13.2.1.4.7.10.2 GENFn PPM

The CPTS_GENFn output cycle can be adjusted by parts per million or by parts per hour. Writing a non-zero value to CPSW_GENF0_PPM_LOW_REG_L/ CPSW_GENF0_PPM_HIGH_REG_L enables PPM operations. The PPM counter continually loads and decrements to zero and then loads again. A single CPTS_RFT_CLK adjustment is made when the PPM counter decrements to zero. The adjustment is up or down depending on the CPSW_GENF0_TS_GENF_CONTROL_REG[0] PPM_DIR bit. When PPM_DIR bit is set a single CPTS_RFT_CLK time is subtracted from the generate function counter which has the effect of increasing the generate function frequency by the PPM amount. When PPM_DIR bit is cleared a single CPTS_RFT_CLK time is added to the generate function counter which has the effect of decreasing the generate function frequency by the PPM amount.

Parts Per Million example:

To adjust for 100 parts per million the configured value for GENF_PPM[41-0] (through CPSW_GENF0_PPM_LOW_REG_L and CPSW_GENF0_PPM_HIGH_REG_L) is:
 $1,000,000/100 = 10,000$ (decimal)

Parts Per Hour example:

To adjust for 1 part per hour at 1 GHz CPTS_RFT_CLK the configured value for GENF_PPM[41-0] (through CPSW_GENF0_PPM_LOW_REG_L and CPSW_GENF0_PPM_HIGH_REG_L) is:
 $(1,000,000,000\text{Hz}/1\text{pph}) * (3600 \text{ seconds}/\text{hour}) = 34630\text{B8A000}$ (hex)

13.2.1.4.7.11 Timestamp ESTFn

Each Ethernet port has a dedicated ESTFn generator which operates identically to the GENFn function.

13.2.1.4.7.12 Time Sync Events

Time Sync events are 96-bit values that are pushed onto the event FIFO and read by software in 32-bit reads. Four 32-bit registers, CPSW_CPTS_EVENT_0_REG through CPSW_CPTS_EVENT_3_REG hold the data of a time sync event. There are eight types of sync events:

- Time Stamp Push Event
- Time Stamp Counter Rollover Event (32-bit mode only)

- Time Stamp Counter Half-rollover Event (32-bit mode only)
- Hardware Time Stamp Push Event
- Ethernet Receive Event
- Ethernet Transmit Event
- Time Stamp Compare Event
- Host Transmit Event

13.2.1.4.7.12.1 Time Stamp Push Event

Software can obtain the current time stamp value (at the time of the write) by initiating a time stamp push event. The push event is initiated by setting the [0]TS_PUSH bit of the CPSW_CPTS_TS_PUSH_REG register. The time stamp value is returned in the event, along with a time stamp push event code. The upper 32-bits (CPSW_CPTS_EVENT_3_REG register) of the timestamp are zero in 32-bit mode.

13.2.1.4.7.12.2 Time Stamp Counter Rollover Event (32-bit mode only)

The CPTS module contains a 32-bit time stamp value (CPSW_CPTS_EVENT_0_REG). The counter upper bits are maintained by host software. The rollover event indicates to software that the time stamp counter has rolled over from 0xFFFF FFFF to 0x0000 0000 and the software-maintained upper count value should be incremented. This event occurs only in 32-bit mode.

13.2.1.4.7.12.3 Time Stamp Counter Half-rollover Event (32-bit mode only)

The CPTS includes a time stamp counter half-rollover event. The half-rollover event indicates to software that the time stamp value (CPSW_CPTS_EVENT_0_REG[31-0] TIME_STAMP) has incremented from 0x7FFF FFFF to 0x8000 0000. The half-rollover event is included to enable software to correct a misaligned event condition. This event occurs only in 32-bit mode.

The half-rollover event is included to enable software to determine the correct time for each event that contains a valid time stamp value, such as an Ethernet event. If an Ethernet event occurs around a counter rollover (full rollover), the rollover event could possibly be loaded into the event FIFO before the Ethernet event, even though the Ethernet event time was actually taken before the rollover. [Figure 13-109](#) shows a misalignment condition. This misaligned event condition arises because an Ethernet event time stamp occurs at the beginning of a packet and time passes before the packet is determined to be a valid synchronization packet. The misaligned event condition occurs if the rollover occurs in the middle, after the packet time stamp has been taken, but before the packet has been determined to be a valid time sync packet.

Host software must detect and correct for misaligned event conditions. For every event time stamp after a rollover and before a half-rollover, software must examine the time stamp most significant bit. If bit 31 of the time stamp value is low (0x0000 0000 through 0x7FFF FFFF), then the event time stamp was taken after the rollover and no correction is required. If the value is high (0x8000 0000 through 0xFFFF FFFF), the time stamp value was taken before the rollover and a misalignment is detected. The misaligned case indicates to software that it must subtract one from the upper count value stored in software to calculate the correct time for the misaligned event. The misaligned event occurs only on the rollover boundary and not on the half-rollover boundary. Software only needs to check for misalignment from a rollover event to a half-rollover event.

When a rollover occurs, software increments the software time stamp upper value. The misaligned case indicates to software that the misaligned event time stamp has a valid upper value that is pre-increment, so one must be subtracted from the upper value to allow software to calculate the correct time for the misaligned event.

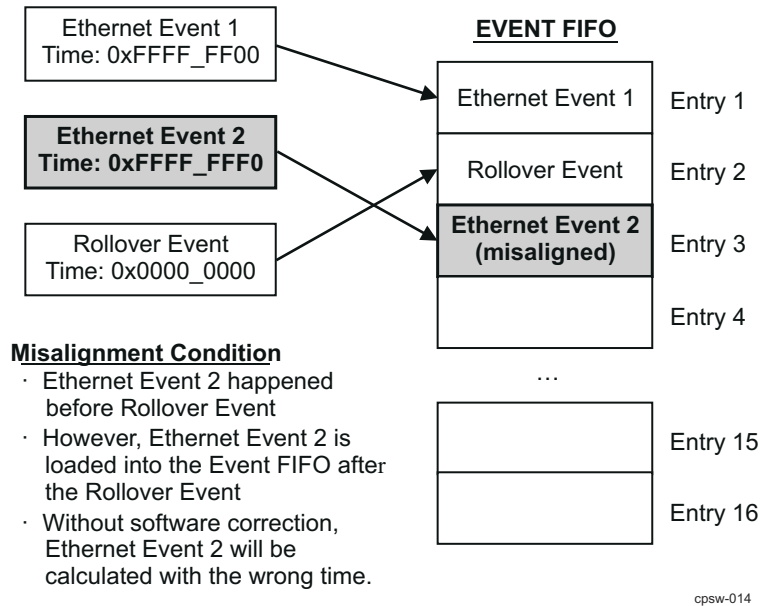

Figure 13-109. Event FIFO Misalignment Condition

13.2.1.4.7.12.4 Hardware Time Stamp Push Event

There are four hardware time stamp inputs (CPTS_HW[1:4]_TS_PUSH events) that can cause hardware time stamp push events to be loaded into the Event FIFO. Each time stamp input is mapped in the device as shown in . The event is loaded into the event FIFO on the rising edge of the timer, and the PORT_NUMBER field in the CPSW_CPTS_EVENT_1_REG register indicates the hardware push input that caused the event (encoded).

The hardware time stamp inputs are asynchronous and are low frequency signals. The CPTS logic synchronizes and performs a rising edge detect on the incoming asynchronous input.

Each hardware time stamp input must be asserted for at least 10 periods of the selected CPTS_RFT_CLK clock. Each input can be enabled or disabled by setting the respective bits in the CPSW_CPTS_CONTROL_REG register.

Hardware time stamps are intended to be an extremely low frequency signals, such that the event FIFO does not overrun. Software must keep up with the event FIFO and ensure that there is no overrun, or events will be lost.

13.2.1.4.7.12.5 Ethernet Port Events

Packets transmitted or received on each Ethernet port can generate Ethernet Transmit Events or Ethernet Receive Events, respectively. The CPTS hardware will decode each packet to determine if it is a valid CPTS time sync event.

According to the IEEE 802.3 Ethernet standard, each Ethernet frame contains a 2-octet EtherType field to indicate which protocol is encapsulated in the PayLoad field, as shown in Figure 13-110. For standard time sync packets, this will contain the EtherType for the Precision Time Protocol (IEEE 1588), which is defined as 0x88F7. The CPTS hardware will compare this field to the TS_LTYPE1 field in the CPSW_PN_TS_SEQ_LTYPE_REG or the TS_LTYPE2 field in CPSW_PN_TS_CTL_LTYPE2_REG register (depending on which enable bit was set) , which should also be programmed to 88F7h.

When a virtual LAN is used, an additional 4-octet 802.1Q tag is inserted in the Ethernet frame before the EtherType field, as shown in Figure 13-110. To indicate to the CPTS hardware that a virtual LAN is in use, the TS_TX_VLAN_LTYPE1_EN (or TS_TX_VLAN_LTYPE2_EN) enable bit must be set in the CPSW_PN_TS_CTL_REG register. The EtherType for the 802.1Q tag is defined as 0x8100, and the CPTS

hardware will compare this value to the TS_VLAN_LTYPE1 (or TS_VLAN_LTYPE2 depending on which enable bit was set) field in the CPSW_PN_TS_VLAN_LTYPE_REG register, which should also be programmed to 0x8100.

When two stacked VLANs are used, two additional 4-octet 801.Q tags are inserted in the Ethernet frame before the EtherType field, as shown in Figure 13-110. In this case, both TS_VLAN_LTYPE1 and TS_VLAN_LTYPE2 must be enabled. The outer tag must match the value of the TS_VLAN_LTYPE1 field, and the inner tag must match the value of the TS_VLAN_LTYPE2 field.

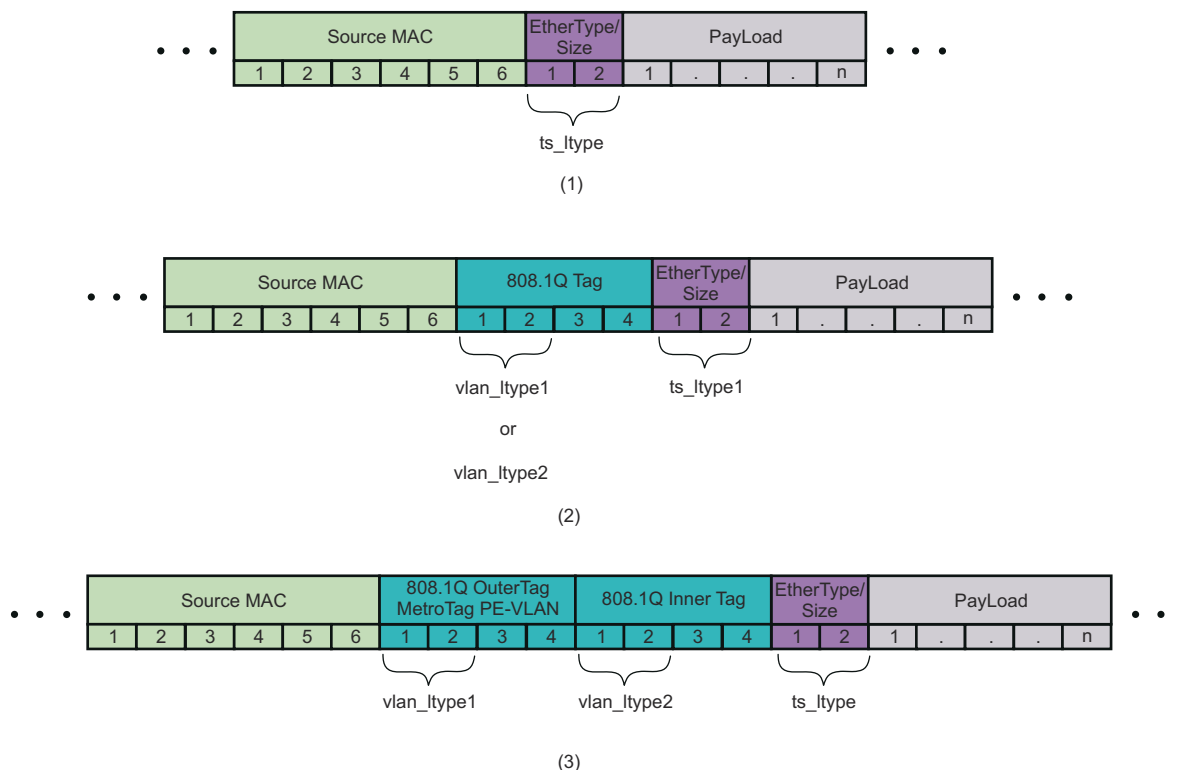

cpsw-015

Figure 13-110. Partial Ethernet-II Frames Showing Register Mapping of EtherTypes for a Simple Frame (1), a Single 1Q Tag Added (2), and Two 1Q Tags Added (3)

13.2.1.4.7.12.5.1 Ethernet Port Receive Event

This section describes Ethernet port receive events. Ethernet port generates time synchronization events for valid received time sync packets. For every packet received on the Ethernet port, a timestamp will be captured by the receive module inside the CPTS for the corresponding port. The time stamp will be captured by the receive module regardless of whether or not the packet is a time synchronization packet to make sure that the time stamp is captured as soon as possible. The packet is sampled on both the rising and falling edges of the CPTS_RFT_CLK, and the time stamp will be captured once the start of frame delimiter for the receive packet is detected.

After the time stamp has been captured, the receive interface will begin parsing the packet to determine if it is a valid Ethernet time synchronization packet. The CPSW decoder determines if the packet is a valid Ethernet receive time synchronization event. The receive interface for the port will use the following criteria to determine if the packet is a valid Annex D, Annex E, or Annex F time synchronization Ethernet receive event:

Annex D (IPv4)

1. Receive annex D time sync is enabled (TS_RX_ANNEX_D_EN is set in the CPSW_PN_TS_CTL_REG register).
2. One of the sequences below is true.
 - a. The first packet LTYPE matches 0x0800

- b. The first packet LTYPE matches TS_VLAN_LTYPE1 in the CPSW_PN_TS_VLAN_LTYPE_REG register and TS_RX_VLAN_LTYPE1_EN is set in the CPSW_PN_TS_CTL_REG register and the second packet LTYPE matches 0x0800
 - c. The first packet LTYPE matches TS_VLAN_LTYPE2 in the CPSW_PN_TS_VLAN_LTYPE_REG register and TS_RX_VLAN_LTYPE2_EN is set in the CPSW_PN_TS_CTL_REG register and the second packet LTYPE matches 0x0800
 - d. The first packet LTYPE matches TS_VLAN_LTYPE1 in the CPSW_PN_TS_VLAN_LTYPE_REG register and TS_RX_VLAN_LTYPE1_EN is set in the CPSW_PN_TS_CTL_REG register and the second packet LTYPE matches TS_VLAN_LTYPE2 in the CPSW_PN_TS_VLAN_LTYPE_REG register and TS_RX_VLAN_LTYPE2_EN is set in the CPSW_PN_TS_CTL_REG register and the third packet LTYPE matches 0x0800
3. Byte 14 (the byte after the LTYPE) contains 0x45 (IPv4).

Note

The byte numbering assumes that there are no VLANs. The byte number is intended to show the relative order of the bytes.

4. Byte 20 contains 0bXXX00000 (5 lower bits zero) and Byte 21 contains 0x00 (fragment offset zero)
 5. Byte 22 contains 0x01 (HOP Limit = 1) if the TS_TTL_NONZERO bit in the switch CPSW_PN_TS_CTL_LTYPE2_REG register is cleared to 0h, or byte 22 contains any value if CPSW_PN_TS_CTL_LTYPE2_REG is set to 1h. Byte 22 is the TTL/HOP field.
 6. Byte 23 contains 0x11 (Next Header UDP Fixed).
 7. The TS_UNI_EN bit in the CPSW_PN_TS_CTL_LTYPE2_REG register is cleared to 0h and Bytes 30 through 33 contain:
 - a. Decimal 224.0.1.129 and the TS_129 bit in the CPSW_PN_TS_CTL_LTYPE2_REG register is set, or
 - b. Decimal 224.0.1.130 and the TS_130 bit in the CPSW_PN_TS_CTL_LTYPE2_REG register is set, or
 - c. Decimal 224.0.1.131 and the TS_131 bit in the CPSW_PN_TS_CTL_LTYPE2_REG register is set, or
 - d. Decimal 224.0.1.132 and the TS_132 bit in the CPSW_PN_TS_CTL_LTYPE2_REG register is set, or
 - e. Decimal 224.0.0.107 and the TS_107 bit in the CPSW_PN_TS_CTL_LTYPE2_REG register is set
- OR-
- The TS_UNI_EN bit in the CPSW_PN_TS_CTL_LTYPE2_REG register is set and Bytes 30 through 33 contain any values.
8. Bytes 36 and 37 contain:
 - a. Decimal 0x01 and 0x3F respectively and the TS_319 bit in the CPSW_PN_TS_CTL_LTYPE2_REG register is set -OR-
 - b. Decimal 0x01 and 0x40 respectively and the TS_320 bit in the CPSW_PN_TS_CTL_LTYPE2_REG register is set.
 9. The PTP message begins in byte 42.
 10. The packet message type is enabled in the TS_MSG_TYPE_EN field in the CPSW_PN_TS_CTL_REG register.
 11. The packet was received without error (not long/short/mac_ctl/CRC/code/align).

Annex E (IPv6)

1. Receive annex E time sync is enabled (TS_RX_ANNEX_E_EN bit is set in the switch CPSW_PN_TS_CTL_REG register).
2. One of the sequences below is true.
 - a. The first packet LTYPE matches 0x86dd.
 - b. The first packet LTYPE matches TS_VLAN_LTYPE1 in the CPSW_PN_TS_VLAN_LTYPE_REG register and TS_RX_VLAN_LTYPE1_EN is set in the CPSW_PN_TS_CTL_REG register and the second packet LTYPE matches 0x86dd
 - c. The first packet LTYPE matches TS_VLAN_LTYPE2 in the CPSW_PN_TS_VLAN_LTYPE_REG register and TS_RX_VLAN_LTYPE2_EN is set in the CPSW_PN_TS_CTL_REG register and the second packet LTYPE matches 0x86dd

- d. The first packet LTYPE matches TS_VLAN_LTYPE1 in the CPSW_PN_TS_VLAN_LTYPE_REG register and TS_RX_VLAN_LTYPE1_EN is set in the CPSW_PN_TS_CTL_REG register and the second packet LTYPE matches TS_VLAN_LTYPE2 in the CPSW_PN_TS_VLAN_LTYPE_REG register and TS_RX_VLAN_LTYPE2_EN is set in the CPSW_PN_TS_CTL_REG register and the third packet LTYPE matches 0x86dd
3. Byte 14 (the byte after the LTYPE) contains 0x6X (IPv6).
4. Byte 20 contains 0x11 (UDP Fixed Next Header).
5. Byte 21 contains 0x01 (Hop Limit = 1) if the TS_TTL_NONZERO bit in the switch CPSW_PN_TS_CTL_LTYPE2_REG register is cleared to 0h, or byte 21 contains any value if TS_TTL_NONZERO is set to 1h. Byte 21 is the TTL/HOP field.
6. The TS_UNI_EN bit in the CPSW_PN_TS_CTL_LTYPE2_REG register is cleared to 0 and Bytes 38 through 53 contain:
 - a. FF0M:0:0:0:0:0:0:0:0:0:0:0:0:0:181 and the TS_129 bit in the CPSW_PN_TS_CTL_LTYPE2_REG register is set, or
 - b. FF0M:0:0:0:0:0:0:0:0:0:0:0:0:0:182 and the TS_130 bit in the CPSW_PN_TS_CTL_LTYPE2_REG register is set, or
 - c. FF0M:0:0:0:0:0:0:0:0:0:0:0:0:0:183 and the TS_131 bit in the CPSW_PN_TS_CTL_LTYPE2_REG register is set, or
 - d. FF0M:0:0:0:0:0:0:0:0:0:0:0:0:0:184 and the TS_132 bit in the CPSW_PN_TS_CTL_LTYPE2_REG register is set, or
 - e. FF0M:0:0:0:0:0:0:0:0:0:0:0:0:0:006B and the TS_107 bit in the CPSW_PN_TS_CTL_LTYPE2_REG register is set

Note

All values above are 16-bit hex numbers where M is enabled in the TS_MCAST_TYPE_EN field in the CPSW_PN_TS_CTL2_REG register.

-OR-

The TS_UNI_EN bit in the CPSW_PN_TS_CTL_LTYPE2_REG register is set to 1h and Bytes 38 through 53 contain any value.

7. Bytes 56 and 57 contain (UDP Header in bytes 54 through 61):
 - a. Decimal 0x01 and 0x3F respectively and the TS_319 bit in the CPSW_PN_TS_CTL2_REG register is set, or
 - b. Decimal 0x01 and 0x40 respectively and the TS_320 bit in the CPSW_PN_TS_CTL2_REG register is set.
8. The PTP message begins in byte 62.
9. The packet message type is enabled in the MSG_TYPE_EN field in the CPSW_PN_TS_CTL2_REG register.
10. The packet was received without error (not long/short/mac_ctl/CRC/code/align).

Annex F (IEEE 802.3)

1. Receive Annex F time sync is enabled (TS_RX_ANNEX_F_EN is set in the switch CPSW_PN_TS_CTL_REG register).
2. One of the sequences below is true:
 - a. The first packet LTYPE matches TS_LTYPE1 in the CPSW_PN_TS_SEQ_LTYPE_REG/ CPSW_PN_TS_SEQ_LTYPE_REG register. LTYPE 1 should be used when only one time sync LTYPE is to be enabled.
 - b. The first packet LTYPE matches TS_LTYPE2 in the CPSW_PN_TS_CTL_LTYPE2_REG register and LTYPE2_EN is set in the CPSW_PN_TS_CTL_REG register.
 - c. The first packet LTYPE matches TS_VLAN_LTYPE1 in the CPSW_PN_TS_VLAN_LTYPE_REG register and TS_RX_VLAN_LTYPE1_EN is set in the CPSW_PN_TS_CTL_REG register and the second packet LTYPE matches TS_LTYPE1 in the CPSW_PN_TS_SEQ_LTYPE_REG register
 - d. The first packet LTYPE matches TS_VLAN_LTYPE1 in the CPSW_PN_TS_VLAN_LTYPE_REG register and TS_RX_VLAN_LTYPE1_EN is set in the CPSW_PN_TS_CTL_REG register and the second packet LTYPE matches TS_LTYPE2 in the CPSW_PN_TS_CTL_LTYPE2_REG register and TS_LTYPE2_EN is set in the CPSW_PN_TS_CTL_REG register.

- e. The first packet LTYPE matches TS_VLAN_LTYPE2 in the CPSW_PN_TS_VLAN_LTYPE_REG register and TS_RX_VLAN_LTYPE2_EN is set in the CPSW_PN_TS_CTL_REG register and the second packet LTYPE matches TS_LTYPE1 in the CPSW_PN_TS_SEQ_LTYPE_REG register.
 - f. The first packet LTYPE matches TS_VLAN_LTYPE2 in the CPSW_PN_TS_VLAN_LTYPE_REG register and TS_RX_VLAN_LTYPE2_EN is set in the CPSW_PN_TS_CTL_REG register and the second packet LTYPE matches TS_LTYPE2 in the CPSW_PN_TS_CTL_LTYPE2_REG register and TS_LTYPE2_EN is set in the CPSW_PN_TS_CTL_REG register.
 - g. The first packet LTYPE matches TS_VLAN_LTYPE1 in the CPSW_PN_TS_VLAN_LTYPE_REG register and TS_RX_VLAN_LTYPE1_EN is set in the CPSW_PN_TS_CTL_REG register and the second packet LTYPE matches TS_VLAN_LTYPE2 in the CPSW_PN_TS_VLAN_LTYPE_REG register and TS_RX_VLAN_LTYPE2_EN is set in the CPSW_PN_TS_CTL_REG register and the third packet LTYPE matches TS_LTYPE1 in the CPSW_PN_TS_SEQ_LTYPE_REG register.
 - h. The first packet LTYPE matches TS_VLAN_LTYPE1 in the CPSW_PN_TS_VLAN_LTYPE_REG register and TS_RX_VLAN_LTYPE1_EN is set in the CPSW_PN_TS_CTL_REG register and the second packet LTYPE matches TS_VLAN_LTYPE2 in the CPSW_PN_TS_VLAN_LTYPE_REG register and TS_RX_VLAN_LTYPE2_EN is set in the CPSW_PN_TS_CTL_REG register and the third packet LTYPE matches TS_LTYPE2 in the CPSW_PN_TS_CTL_LTYPE2_REG register and TS_LTYPE2_EN is set in the CPSW_PN_TS_CTL_REG register
3. The PTP message begins in the byte after the LTYPE.
 4. The packet message type is enabled in the TS_MSG_TYPE_EN field in the CPSW_PN_TS_CTL_REG register.
 5. The packet was received without error (not long/short/mac_ctl/CRC/code/align).

If all of the criteria described above are met for either Annex D, Annex E, or Annex F, and the packet is determined to be a valid time synchronization packet, then the RX interface will push an Ethernet receive event into the event FIFO.

13.2.1.4.7.12.5.2 Ethernet Port Transmit Event

This section describes Ethernet port transmit events. For every packet transmitted on the Ethernet ports, the port transmit interface will begin parsing the packet to determine if it is a valid Ethernet time synchronization packet. The CPTS transmit interface for the port will use the following criteria to determine if the packet is a valid time synchronization Ethernet transmit event. The CPSW decoder determines if the packet is a valid ethernet receive time synchronization event. To be a valid Ethernet transmit time synchronization event, the conditions listed below must be true for either Annex D, Annex E, or Annex F:

Annex D (IPv4)

1. Transmit time sync is enabled (TS_TX_ANNEX_D_EN is set in the CPSW_PN_TS_CTL_REG register).
2. One of the sequences below is true.
 - a. The first packet LTYPE matches 0x0800
 - b. The first packet LTYPE matches TS_VLAN_LTYPE1 in the CPSW_PN_TS_VLAN_LTYPE_REG register and TS_TX_VLAN_LTYPE1_EN is set in the CPSW_PN_TS_CTL_REG register and the second packet LTYPE matches 0x0800
 - c. The first packet LTYPE matches TS_VLAN_LTYPE2 in the CPSW_PN_TS_VLAN_LTYPE_REG register and TS_TX_VLAN_LTYPE2_EN is set in the CPSW_PN_TS_CTL_REG register and the second packet LTYPE matches 0x0800
 - d. The first packet LTYPE matches TS_VLAN_LTYPE1 in the CPSW_PN_TS_VLAN_LTYPE_REG register and TS_TX_VLAN_LTYPE1_EN is set in the CPSW_PN_TS_CTL_REG register and the second packet LTYPE matches TS_VLAN_LTYPE2 in the CPSW_PN_TS_VLAN_LTYPE_REG register and TS_TX_VLAN_LTYPE2_EN is set in the CPSW_PN_TS_CTL_REG register and the third packet LTYPE matches 0x0800
3. Byte 14 (the byte after the LTYPE) contains 0x45 (IPv4).

Note

The byte numbering assumes that there are no VLANs. The byte number is intended to show the relative order of the bytes.

4. Byte 20 contains 0bXXX00000 (5 lower bits zero) and Byte 21 contains 0x00 (fragment offset zero)
5. Byte 22 contains 0x01 (HOP Limit = 1) if the TS_TTL_NONZERO bit in the switch CPSW_PN_TS_CTL_LTYPE2_REG register is cleared to 0h, or byte 22 contains any value if TS_TTL_NONZERO is set to 1h. Byte 22 is the TTL/HOP field.
6. Byte 23 contains 0x11 (Next Header UDP Fixed).
7. The TS_UNI_EN bit in the CPSW_PN_TS_CTL_LTYPE2_REG register is cleared to 0h and Bytes 30 through 33 contain:
 - a. Decimal 224.0.1.129 and the TS_129 bit in the CPSW_PN_TS_CTL_LTYPE2_REG register is set, or
 - b. Decimal 224.0.1.130 and the TS_130 bit in the CPSW_PN_TS_CTL_LTYPE2_REG register is set, or
 - c. Decimal 224.0.1.131 and the TS_131 bit in the CPSW_PN_TS_CTL_LTYPE2_REG register is set, or
 - d. Decimal 224.0.1.132 and the TS_132 bit in the CPSW_PN_TS_CTL_LTYPE2_REG register is set, or
 - e. Decimal 224.0.0.107 and the TS_107 bit in the CPSW_PN_TS_CTL_LTYPE2_REG register is set, or
 - f. The TS_UNI_EN bit in the CPSW_PN_TS_CTL_LTYPE2_REG register is set and Bytes 30 through 33 contain any values.
8. Bytes 36 and 37 contain:
 - a. Decimal 0x01 and 0x3F respectively and the TS_319 bit in the CPSW_PN_TS_CTL_LTYPE2_REG register is set, or
 - b. Decimal 0x01 and 0x40 respectively and the TS_320 bit in the CPSW_PN_TS_CTL_LTYPE2_REG register is set.
9. The PTP message begins in byte 42.
10. The packet message type is enabled in the TS_MSG_TYPE_EN field in the CPSW_PN_TS_CTL_REG register.
11. The packet was sent by host port 0.

Annex E (IPv6)

1. Transmit annex E time sync is enabled (TS_TX_ANNEX_E_EN bit is set in the switch CPSW_PN_TS_CTL_REG register).
2. One of the sequences below is true.
 - a. The first packet LTYPE matches 0x86dd.
 - b. The first packet LTYPE matches TS_VLAN_LTYPE1 in the CPSW_PN_TS_VLAN_LTYPE_REG register and TS_TX_VLAN_LTYPE1_EN is set in the CPSW_PN_TS_CTL_REG register and the second packet LTYPE matches 0x86dd
 - c. The first packet LTYPE matches TS_VLAN_LTYPE2 in the CPSW_PN_TS_VLAN_LTYPE_REG register and TS_TX_VLAN_LTYPE2_EN is set in the CPSW_PN_TS_CTL_REG register and the second packet LTYPE matches 0x86dd
 - d. The first packet LTYPE matches TS_VLAN_LTYPE1 in the CPSW_PN_TS_VLAN_LTYPE_REG register and TS_TX_VLAN_LTYPE1_EN is set in the CPSW_PN_TS_CTL_REG register and the second packet LTYPE matches TS_VLAN_LTYPE2 in the CPSW_PN_TS_VLAN_LTYPE_REG register and TS_TX_VLAN_LTYPE2_EN is set in the CPSW_PN_TS_CTL_REG register and the third packet LTYPE matches 0x86dd
3. Byte 14 (the byte after the LTYPE) contains 0x6X (IPv6).
4. Byte 20 contains 0x11 (UDP Fixed Next Header).
5. Byte 21 contains 0x01 (Hop Limit = 1) if the TS_TTL_NONZERO bit in the switch CPSW_PN_TS_CTL_LTYPE2_REG register is cleared to 0h, or byte 21 contains any value if TS_TTL_NONZERO is set to 1h. Byte 21 is the TTL/HOP field..
6. The TS_UNI_EN bit in the CPSW_PN_TS_CTL_LTYPE2_REG register is cleared to 0 and Bytes 38 through 53 contain:
 - a. FF0M:0:0:0:0:0:0:0181 and the TS_129 bit in the CPSW_PN_TS_CTL_LTYPE2_REG register is set, or
 - b. FF0M:0:0:0:0:0:0:0182 and the TS_130 bit in the CPSW_PN_TS_CTL_LTYPE2_REG register is set, or
 - c. FF0M:0:0:0:0:0:0:0183 and the TS_131 bit in the CPSW_PN_TS_CTL_LTYPE2_REG register is set, or
 - d. FF0M:0:0:0:0:0:0:0184 and the TS_132 bit in the CPSW_PN_TS_CTL_LTYPE2_REG register is set, or
 - e. FF0M:0:0:0:0:0:0:006B and the TS_107 bit in the CPSW_PN_TS_CTL_LTYPE2_REG register is set

Note

All values above are 16-bit hex numbers where M is enabled in the TS_MCAST_TYPE_EN field in the CPSW_PN_TS_CTL2_REG register.

-OR-

The TS_UNI_EN bit in the CPSW_PN_TS_CTL_LTYPE2_REG register is set to 1h and Bytes 38 through 53 contain any value.

7. Bytes 56 and 57 contain (UDP Header in bytes 54 through 61):
 - a. Decimal 0x01 and 0x3F respectively and the TS_319 bit in the CPSW_PN_TS_CTL_LTYPE2_REG register is set, or
 - b. Decimal 0x01 and 0x40 respectively and the TS_320 bit in the CPSW_PN_TS_CTL_LTYPE2_REG register is set.
8. The PTP message begins in byte 62.
9. The packet message type is enabled in the TS_MSG_TYPE_EN field in the CPSW_PN_TS_CTL_REG register.
10. The packet was sent by host port 0.

Annex F (IEEE 802.3)

1. Transmit time sync is enabled (TS_TX_ANNEX_F_EN is set in the switch CPSW_PN_TS_CTL_REG register).
2. One of the sequences below is true:
 - a. The first packet LTYPE matches TS_LTYPE1 in the CPSW_PN_TS_SEQ_LTYPE_REG register. LTYPE 1 should be used when only one time sync LTYPE is to be enabled.
 - b. The first packet LTYPE matches TS_LTYPE2 in the CPSW_PN_TS_CTL_LTYPE2_REG register and TS_LTYPE2_EN is set in the CPSW_PN_TS_CTL_REG register.
 - c. The first packet LTYPE matches TS_VLAN_LTYPE1 in the CPSW_PN_TS_VLAN_LTYPE_REG register and TS_TX_VLAN_LTYPE1_EN is set in the CPSW_PN_TS_CTL_REG register and the second packet LTYPE matches TS_LTYPE2 in the CPSW_PN_TS_CTL_LTYPE2_REG register.
 - d. The first packet LTYPE matches TS_VLAN_LTYPE2 in the CPSW_PN_TS_VLAN_LTYPE_REG register and TS_TX_VLAN_LTYPE2_EN is set in the CPSW_PN_TS_CTL_REG register and the second packet LTYPE matches TS_LTYPE1 in the CPSW_PN_TS_SEQ_LTYPE_REG register.
 - e. The first packet LTYPE matches TS_VLAN_LTYPE2 in the CPSW_PN_TS_VLAN_LTYPE_REG register and TS_TX_VLAN_LTYPE2_EN is set in the CPSW_PN_TS_CTL_REG register and the second packet LTYPE matches TS_LTYPE2 in the CPSW_PN_TS_CTL_LTYPE2_REG register.
 - f. The first packet LTYPE matches TS_VLAN_LTYPE1 in the CPSW_PN_TS_VLAN_LTYPE_REG register and TS_TX_VLAN_LTYPE1_EN is set in the CPSW_PN_TS_CTL_REG register and the second packet LTYPE matches TS_LTYPE2 in the CPSW_PN_TS_CTL_LTYPE2_REG register and TS_LTYPE2_EN is set in the CPSW_PN_TS_CTL_REG register.
 - g. The first packet LTYPE matches TS_VLAN_LTYPE1 in the CPSW_PN_TS_VLAN_LTYPE_REG register and TS_TX_VLAN_LTYPE1_EN is set in the CPSW_PN_TS_CTL_REG register and the second packet LTYPE matches TS_VLAN_LTYPE2 in the CPSW_PN_TS_VLAN_LTYPE_REG register and TS_TX_VLAN_LTYPE2_EN is set in the CPSW_PN_TS_CTL_REG register and the third packet LTYPE matches TS_LTYPE2 in the CPSW_PN_TS_CTL_LTYPE2_REG register.
 - h. The first packet LTYPE matches TS_VLAN_LTYPE1 in the CPSW_PN_TS_VLAN_LTYPE_REG register and TS_TX_VLAN_LTYPE1_EN is set in the CPSW_PN_TS_CTL_REG register and the second packet LTYPE matches TS_VLAN_LTYPE2 in the CPSW_PN_TS_VLAN_LTYPE_REG register and TS_TX_VLAN_LTYPE2_EN is set in the CPSW_PN_TS_CTL_REG register and the third packet LTYPE matches TS_LTYPE2 in the CPSW_PN_TS_CTL_LTYPE2_REG register and TS_LTYPE2_EN is set in the CPSW_PN_TS_CTL_REG register.
3. The packet message type is enabled in the TS_MSG_TYPE_EN field in the CPSW_PN_TS_CTL_REG register.
4. The packet was sent by host port 0.

If all of the criteria described above are met, and the packet is determined to be a valid time synchronization packet, then the time stamp for the transmit event will not be generated until the start of frame delimiter of the packet is actually transmitted. The start of frame delimiter will be sampled on every rising and falling edge of the CPTS_RFT_CLK. Once the packet is transmitted, then the TX interface will push an Ethernet transmit event into the event FIFO.

Table 13-152. Values of Message Type Field

Message Type	Value (hex)
Sync	0
Delay_Req	1
Pdelay_Req	2
Pdelay_Resp	3
Reserved	4:7
Follow_Up	8
Delay_Resp	9
Pdelay_Resp_Follow_Up	A
Announce	B
Signaling	C
Management	D
Reserved	E:F

Once a transmitted or received packet is determined to be a valid time sync packet, the Ethernet Transmit Event or Ethernet Receive Event is loaded onto the Event FIFO.

The CPSW_CPTS_EVENT_1_REG register contains the Message Type and Sequence ID values from the original time sync packet. The CPSW_CPTS_EVENT_0_REG (and CPSW_CPTS_EVENT_3_REG) register contains the time stamp value when the packet arrived at the corresponding port.

13.2.1.4.7.12.5.3

Table 13-153. Values of Message Type Field

Message Type	Value (hex)
Sync	0
Delay_Req	1
Pdelay_Req	2
Pdelay_Resp	3
Reserved	4:7
Follow_Up	8
Delay_Resp	9
Pdelay_Resp_Follow_Up	A
Announce	B
Signaling	C
Management	D
Reserved	E:F

Once a transmitted or received packet is determined to be a valid time sync packet, the Ethernet Transmit Event or Ethernet Receive Event is loaded onto the Event FIFO.

The CPSW_CPTS_EVENT_1_REG register contains the Message Type and Sequence ID values from the original time sync packet. The CPSW_CPTS_EVENT_0_REG (and CPSW_CPTS_EVENT_3_REG) register contains the time stamp value when the packet arrived at the corresponding port.

13.2.1.4.7.13 Timestamp Compare Event

Note

Timestamp compare events are generated for non-toggle mode only.

The CPTS can generate an event for a time stamp comparison in 32-bit or 64-bit mode.

13.2.1.4.7.13.1 32-Bit Mode

The CPTS_COMP output is also asserted when the event is generated. The event is generated when the 32-bit time stamp value (CPSW_CPTS_EVENT_0_REG) compares with the CPSW_CPTS_TS_COMP_VAL_REG register and the CPSW_CPTS_TS_COMP_LEN_REG value is non-zero. The CPSW_CPTS_TS_COMP_LEN_REG value should be written by software after the CPSW_CPTS_TS_COMP_VAL_REG register is written and should be zero when the comparison value is written.

13.2.1.4.7.13.2 64-Bit Mode

The CPTS_COMP output is also asserted when the event is generated. The event is generated when the 64-bit time stamp value (CPSW_CPTS_EVENT_0_REG and CPSW_CPTS_EVENT_3_REG) compares with the CPSW_CPTS_TS_COMP_VAL_REG and CPSW_CPTS_TS_COMP_HIGH_VAL_REG registers and the CPSW_CPTS_TS_COMP_LEN_REG value is non-zero. The CPSW_CPTS_TS_COMP_LEN_REG value should be written by software after the CPSW_CPTS_TS_COMP_VAL_REG register is written and should be zero when the comparison value is written.

13.2.1.4.7.14 Host Transmit Event

The host can send a packet to be transmitted on an Ethernet port that will generate a time synchronization event. The host sets the TSTAMP_EN bit and sends the DOMAIN, MESSAGE_TYPE, and SEQUENCE_ID in the additional control information that resides in the protocol specific section of the descriptor that is transmitted to the CPSW_2G. An event is then generated and placed on the event FIFO once the packet is transmitted. Host events allow the user to timestamp exactly when a software generated packet exits the device.

13.2.1.4.7.15 CPTS Interrupt Handling

When an event is push onto the Event FIFO, an interrupt can be generated to indicate to software that a time sync event occurred. The following steps should be taken to process time sync events using interrupts:

1. Enable the TS_PEND interrupt by setting the TS_PEND_EN bit of the CPSW_CPTS_INT_ENABLE_REG register.
2. Upon interrupt, read the CPSW_CPTS_EVENT_0_REG through CPSW_CPTS_EVENT_3_REG registers values.
3. Set the CPSW_CPTS_EVENT_POP_REG[0] EVENT_POP bit to 1h to pop the previously read value off of the event FIFO.
4. Process the interrupt as required by the application software.

Software has the option of processing more than a single event from the event FIFO in the interrupt service routine in the following way:

1. Enable the TS_PEND interrupt by setting the TS_PEND_EN bit of the CPSW_CPTS_INT_ENABLE_REG
2. Upon interrupt, enter the CPTS service routine.
3. Read the CPSW_CPTS_EVENT_0_REG through CPSW_CPTS_EVENT_3_REG registers values.
4. Set the CPSW_CPTS_EVENT_POP_REG[0] EVENT_POP bit to 1h to pop the previously read value off of the event FIFO.
5. Wait for an amount of time greater than four CPTS_RFT_CLK periods plus four CPPI_ICLK periods.
6. Read the TS_PEND_RAW bit in the CPSW_CPTS_INTSTAT_RAW_REG register to determine if another valid event is in the event FIFO. If bit TS_PEND_RAW is asserted, go to step 3. If bit TS_PEND_RAW is not asserted proceed with step 7.
7. Process the interrupt(s) as required by the application software.

Software also has the option of disabling the interrupt and polling the TS_PEND_RAW bit of the CPSW_CPTS_INTSTAT_RAW_REG register to determine if a valid event is on the event FIFO.

13.2.1.4.8 CPPI Streaming Packet Interface

The receive streaming interface on port 0 of the CPSW is responsible for receiving packet for Ethernet egress data from the packet streaming switch in the . The CPPI receive port is equivalent to an Ethernet port with the difference being that the data is provided to the CPSW in the 128-bit streaming interface data format instead RGMII data format.

In addition to the packet data, the receive streaming interface also can provide additional control information that resides in the information words of the descriptor that was transmitted to the CPSW.

The tables below show the information that may be passed along with which descriptor information word to put it in.

13.2.1.4.8.1 Port 0 CPPI Transmit Packet Streaming Interface (CPSW_3G Egress)

The CPSW2G has a single transmit packet streaming interface. All Ethernet packet data destined for the host (Port 0) is transferred on the transmit packet streaming interface. The transmit packet streaming interface is equivalent to an Ethernet MAC output with the difference being that 128-bit streaming interface data is output. Egress packet data is packed on the 128-bit data bus with all words having 16-bytes except possibly the last packet data word which is the word previous to the EOP word. INFO Word 0–3 is transferred on SOP. The EOP word contains the packet status 0–3 (data type 24) which includes the timestamp and checksum data. Packets are not dropped on the transmit streaming interface due to pushback, but packets may be dropped in the associated priority FIFO.

INFO Word 0–3 and Status Data Word 0–3 (on EOP) are the only non-payload data word types that are transferred. Long packets are truncated at the CPSW_PN_RX_MAXLEN_REG_k[13-0] RX_MAXLEN byte value of the ingress port (only the CPSW_PN_RX_MAXLEN_REG_k number of bytes are kept if long packets are transferred due to CPSW_PN_MAC_CONTROL_REG_k register copy error frames set - RX_CEF_EN). MAC control frames are only transferred if the receiving Ethernet port has the CPSW_PN_MAC_CONTROL_REG_k[24] RX_CMF_EN bit set.

The error encoding on the TXST_PKT_ERR[3:0] output is shown in [Table 13-154](#):

Table 13-154. Error Encoding on the TXST_PKT_ERR[3:0] Output

TXST_PKT_ERR[3:0]	Description
0000	No Error
0001	CRC Error
0010	Code or alignment error
0011	Short (no code/align/crc error)
0100	FragCRC (short with crc error)
0101	Frag Code/Align (short with code/align error)
0110	Long
0111	Jabber CRC (long with crc error)
1000	Jabber Code/Align (long with code/align error)
1001	Mac ontrl packet (CPSW_PN_MAC_CONTROL_REG_k[24] RX_CMF_EN set on ingress Ethernet port)
1010	Mac control CRC
1011	Mac control Code/Align
1100	Mac control short/frag (short MAC control frame with CRC/Code/Align)
1101	Mac control long/jabber (long MAC control frame with CRC/Code/Align)
1110	Reserved
1111	Reserved

The CPPI Port 0 transmit packet streaming interface has a single output thread. If a packet transmission has begun then the entire packet will be transmitted before the next packet is sent (packet data from multiple packets are not interleaved on the transmit streaming interface). The default egress flow is the port number minus 1, concatenated with the 3-bit Port 0 transmit FIFO hardware switch priority. For example, a packet that was received on port 4 with a Port 0 transmit FIFO hardware switch priority of 5 would be sent on flow 29 (decimal) or flow 0b0011101 (binary). Priority remapping on ingress and Port 0 transmit egress effects the output flow.

INFO Words are a contiguous block of four 32-bit data words aligned on a 32-bit word boundary.

Figure 13-111. TX INFO Word 0 Format

31	30	29	28	27	26	25	24	23	22	21	20	19	18	17	16	
PKT_TYPE				RESERVED				PASS_CRC	CRC_T YPE	RESERVED						
15	14	13	12	11	10	9	8	7	6	5	4	3	2	1	0	
RESERVED								FLOW_ID								

Bit	Field	Description
31-27	PKT_TYPE	Always set to 0b00111. Host PD (Packet Descriptor) Word 2. Packet Type: bits[31-27].
26-24	RESERVED	Reserved.
23	PASS_CRC	This bit is cleared to zero (no CRC passed) when the P0_TX_CRC_REMOVE bit in the CPSW_CONTROL_REG register is set (and the egress packet has no errors). When the remove bit is cleared to zero then this bit is cleared and no CRC is passed with the output packet. The packet length includes the CRC if it is present.
22	CRC_TYPE	The packet CRC type. The type of CRC passed is determined by CRC_TYPE field in the CPSW_PN_MAC_CONTROL_REG_k register (not by the type of CRC the packet had on Ethernet port ingress). Host PD Word 1. Protocol Specific Flags: bits[27-24]. 0h: Ethernet CRC 1h: Castagnoli CRC
21-8	RESERVED	Reserved.
7-0	FLOW_ID	This is the packet output transmit streaming interface flow. The default flow ID can be overridden by ALE classification (Thread mapping). The switch default flow is the 3-bit "From Port" value concatenated with the 3-bit "Switch Priority" {From_Port[2:0], Switch_Priority[2:0]} as shown below: Host PD (Packet Descriptor) Word 1. Flow ID: bits[13-0]. 0h: The packet was received on Ethernet port 1 Switch Priority – The actual hardware switch priority that the packet was stored in on the CPPI transmit FIFO.

Figure 13-112. TX INFO Word 1 Format

31	30	29	28	27	26	25	24	23	22	21	20	19	18	17	16
0x4 (fixed_ps_size)											0				
15	14	13	12	11	10	9	8	7	6	5	4	3	2	1	0
0	PKT_LENGTH														

Bit	Field	Description
31-20	FIXED_PS_SIZE	Fixed packet size: 0x4
19-14	RESERVED	Reserved.

Bit	Field	Description
13-0 (Host PD (Packet Descriptor) Word 1. Packet Length: bits[21-0])	PKT_LENGTH	Specifies the number of bytes in the entire packet. Offset bytes are not included. Valid only on SOP. The packet length must be greater than zero. The packet data will be truncated to the packet length if the packet length is shorter than the sum of the packet buffer descriptor buffer lengths. A host error occurs if the packet length is greater than the sum of the packet buffer descriptor buffer lengths.

Figure 13-113. TX INFO Word 2 Format

31	30	29	28	27	26	25	24	23	22	21	20	19	18	17	16
0															
15	14	13	12	11	10	9	8	7	6	5	4	3	2	1	0
0xFFFF															

Figure 13-114. TX INFO Word 3 Format

31	30	29	28	27	26	25	24	23	22	21	20	19	18	17	16
0								SRC_ID							
15	14	13	12	11	10	9	8	7	6	5	4	3	2	1	0
0															

Bit	Field	Description
31-24	RESERVED	Reserved.
23-16	SRC_ID	The packet SRC_ID value comes from the PORT1 field in the CPSW_P0_SRC_ID_A_REG register. (src_tag) PD (Packet Descriptor) Word 3. Source Tag Low bits[23-16] if RFLOW[a]_RFC.rx_src_tag_lo_sel = 0x4 or (src_tag) PD (Packet Descriptor) Word 3. Source Tag High bits[31-24] if RFLOW[a]_RFC.rx_src_tag_hi_sel = 0x4
15-0	RESERVED	Reserved.

Note

TX Status Data Word [0..3] are mapped to Host Packet Descriptor Protocol Specific Words if RFLOW[a]_RFA.rx_psinfo_present = 1 and RFLOW[a]_RFA.rx_ps_location = 0

Figure 13-115. TX Status Data Word 0 Format

31	30	29	28	27	26	25	24	23	22	21	20	19	18	17	16
TIMESTAMP[31:0]															
15	14	13	12	11	10	9	8	7	6	5	4	3	2	1	0
TIMESTAMP[31:0]															

Bit	Field	Description
31-0	TIMESTAMP[31:0]	Contains the lower 32-bits of the time stamp value.

Figure 13-116. TX Status Data Word 1 Format

31	30	29	28	27	26	25	24	23	22	21	20	19	18	17	16
TIMESTAMP[63:32]															
15	14	13	12	11	10	9	8	7	6	5	4	3	2	1	0

Figure 13-116. TX Status Data Word 1 Format (continued)

TIMESTAMP[63:32]		
Bit	Field	Description
31-0	TIMESTAMP[63:32]	Contains the upper 32-bits of the time stamp value.

Figure 13-117. TX Status Data Word 2 Format

31	30	29	28	27	26	25	24	23	22	21	20	19	18	17	16
RESERVED											IPV4_VALID	IPV6_VALID	TCP_UDP_N	FRAGMENT	CHECKSUM_ERROR
15	14	13	12	11	10	9	8	7	6	5	4	3	2	1	0
CHECKSUM_ADD															

Bit	Field	Description
31-21	RESERVED	Reserved.
20	IPV4_VALID	An IPV4 TCP or UDP Packet was detected.
19	IPV6_VALID	An IPV6 TCP or UDP Packet was detected.
18	TCP_UDP_N	Valid only when either the IPV4_VALID or IPV6_VALID bits are set. 0h: Indicates UDP packet was detected. 1h: Indicates TCP packet was detected.
17	FRAGMENT	Indicates that an IP fragment was detected. Valid only when when either the IPV4_VALID or IPV6_VALID bits are set.
16	CHECKSUM_ERROR	Valid only when either the IPV4_VALID or IPV6_VALID bits are set.
15-0	CHECKSUM_ADD	This is the value that was summed during the checksum computation. This value is FFFFh for IPV4/6 UDP/TCP packets with no checksum error.

Figure 13-118. TX Status Data Word 3 Format

31	30	29	28	27	26	25	24	23	22	21	20	19	18	17	16
0															
15	14	13	12	11	10	9	8	7	6	5	4	3	2	1	0
0															
Bit	Field	Description													
31-0	RESERVED	Reserved.													

13.2.1.4.8.2 Port 0 CPPI Receive Packet Streaming Interface (CPSW_3G Ingress)

Info Word 0/1/2/3 (INFO1 and INFO3 are ignored) are transferred on SOP. If a timestamp word (Extended Packet Info Word 0/1/2/3) is to be transferred it must be after SOP and before any packet data is transferred. Any following non-data type words will be dropped. The EOP word must be payload data.

Input receive packets cannot be aborted by the host. The INFO Word bit descriptions and Extended Packet INFO Word bit descriptions are shown below. The PASS_CRC bit indicates that the CRC is passed with the packet data. Packets that have a passed CRC that is an error CRC will be output on the Ethernet port with at least one CRC byte inverted to indicate the error if P0_RX_PASS_CRC_ERR bit is set, otherwise they are dropped. The packet is a directed packet when any of the TO_PORT bits are nonzero. A packet may be directed only to a single port. The packet will be sent to the port number indicated. For directed packets the lookup process is skipped to determine the destination. However, in vlan aware mode (when VLAN_AWARE bit in the CPSW_CONTROL_REG register is set to 1h) the lookup is performed to determine untagged egress. Packets longer than the value in CPSW_P0_RX_MAXLEN_REG[13:0] RX_MAXLEN bit field are dropped.

Packets shorter than 60-Bytes are padded to 64-Bytes (after adding pad and CRC) if P0_RX_PAD bit in the CPSW_CONTROL_REG register is set and if PASS_CRC is clear, otherwise they are dropped. This means that packets shorter than 64-Bytes are dropped if the PASS_CRC info bit is set regardless of P0_RX_PAD bit (packets are padded only if they are short and do not have CRC).

A RX INFO word is a contiguous block of four 32-bit data words aligned on a 32-bit word boundary.

Note

RX Control Data Words [0..2] are mapped to Host Packet Descriptor Protocol Specific Words if (TCHAN[a]_TCFG.tx_filt_pswords = 0) and (Host PD Word 1.Protocol Specific Region Location.bit[28] = 0h) and (Host PD Word 1.Protocol Specific Valid Word Count.bits[22-27] = 4h)

Figure 13-119. RX INFO Word 0 Format

31	30	29	28	27	26	25	24	23	22	21	20	19	18	17	16	
RESERVED								PASS_CRC	CRC_T YPE	RESERVED						
15	14	13	12	11	10	9	8	7	6	5	4	3	2	1	0	
RESERVED																

Bit	Field	Description
31-24	RESERVED	Reserved.
23	PASS_CRC	The PASS_CRC bit indicates that the CRC is passed with the packet data. 0h: CRC is not passed with packet (CRC_TYPE is don't care) 1h: CRC of type CRC_TYPE is passed with the packet.
22 (Host PD (Packet Descriptor) Word 1. Protocol Specific Flags: bits[27-24])	CRC_TYPE	CRC Type 0h: Ethernet CRC 1h: Castagnoli CRC
21-0	RESERVED	Reserved.

Figure 13-120. RX INFO Word 2 Format

31	30	29	28	27	26	25	24	23	22	21	20	19	18	17	16
RESERVED											TO_PORT				
15	14	13	12	11	10	9	8	7	6	5	4	3	2	1	0
RESERVED															

Bit	Field	Description
31-21	RESERVED	Reserved.
20-16 (Host PD (Packet Descriptor) Word 3. Dest Tag Low bits[8-0])	TO_PORT	Port number to send the directed packet to. This field is set by the host. This field is valid on SOP. Directed packets go to the directed port, but an ALE lookup is performed to determine untagged egress in VLAN_AWARE mode. 0h: Not directed 1h: Send the packet to port 1.
15-0	RESERVED	Reserved.

Figure 13-121. RX Control Data Word 1 Format

31	30	29	28	27	26	25	24	23	22	21	20	19	18	17	16
TIMES TAMP_ EN	RESERVED			DOMAIN								MSG_TYPE			
15	14	13	12	11	10	9	8	7	6	5	4	3	2	1	0
SEQUENCE_ID															

Bit	Field	Description
31	TIMESTAMP_EN	When set, this bit indicates that the packet will generate a timesync event on Ethernet egress (if the CPTS is configured properly) with the associated DOMAIN, MSG_TYPE, and SEQUENCE_ID.
30-28	RESERVED	Reserved.
27-20	DOMAIN	Timesync domain.
19-16	MSG_TYPE	Timesync message type.
15-0	SEQUENCE_ID	Timesync sequence ID.

Figure 13-122. RX Control Data Word 2 Format

31	30	29	28	27	26	25	24	23	22	21	20	19	18	17	16
CHECKSUM_RESULT								CHECKSUM_START_BYTE							
15	14	13	12	11	10	9	8	7	6	5	4	3	2	1	0
CHEC KSUM _INV	RESE RVED	CHECKSUM_BYTECOUNT													

Bit	Field	Description
31-24	CHECKSUM_RESULT	This is the packet byte number where the checksum result will be placed in the egress packet. The first packet byte which is the first byte of the destination address is Byte 1 (not byte zero).
23-16	CHECKSUM_START_BYTE	This is the packet byte number to start the checksum calculation on. The first packet byte is Byte 1.
15	CHECKSUM_INV	When set, a zero checksum value will be inverted and sent as FFFFh.
14	RESERVED	Reserved.
13-0	CHECKSUM_BYTECOUNT	This is the number of bytes to calculate the checksum on. The outgoing Ethernet packet will have a checksum inserted when this value is non-zero.

Other INFO words are not taken into account.

13.2.1.4.8.3 Port Speed

Cut-thru operations require that the Ethernet port speeds be known. Port speed can be set manually by software or be automatically determined by the hardware. A zero port speed causes the port to be disabled for cut-thru operations, but does not disable the port. The port speed values are as follows:

- 0000 – Port speed operations disabled (not a port disable)
- 0001 – 10Mbps
- 0010 – 100Mbps
- 0011 – 1G
- 0100 – 2.5G
- 0101 – 5G
- 0110 – 10G
- 0111 through 1111 Reserved

When the CPSW_PN_SPEED_REG_k[8] AUTO_SPEED_EN bit is cleared, the port speed is written by software. When the CPSW_PN_SPEED_REG_k[8] AUTO_SPEED_EN bit is set, the port speed is automatically detected by the hardware.

13.2.1.4.8.4 CPPI Checksum Offload

The CPPI host port can be enabled to perform checksum offload on host port packet ingress and egress. UDP (User Datagram Protocol) and TCP (Transmission Control Protocol) over IPV4 and IPV6 are supported. For the purposes of checksum description, the first packet byte (the first byte of the destination address) is byte 1 (not byte 0). That is, a 64 byte packet goes from byte 1 to byte 64. For all packet types, the S_CN_SWITCH bit in the CPSW_CONTROL_REG register must be set for the Outer VLAN L type to be supported.

13.2.1.4.8.4.1 CPPI Transmit Checksum Offload

IPV4 and IPV6 UDP and TCP packets that are received on any Ethernet port and destined for port 0 egress are checked for correct checksum as described below. The byte counts below are shown for packets with no VLAN's. The byte counts vary with one or two packet VLAN's. Packets received on an Ethernet port with errors are not checked for a correct checksum if they are passed to the host.

13.2.1.4.8.4.1.1 IPV4 UDP

- Byte 15 Upper Nibble = 4 for IPV4
- Byte 15 Lower Nibble = IHL - Nibble with number of 32-bit words in IPV4 header (5 to 15 supported).
- Bytes 20-21 = fragment[15-0] – Bit 13 is the MF bit and bits [12-0] are the Fragment offset. A packet is a fragment if the MF bit is set or if the fragment offset is non-zero. The first packet fragment has MF=1 with a zero offset. Middle fragments have MF=1 with a nonzero offset. The last packet fragment has MF=0 with a nonzero offset. Non-fragmented packets have MF=0 and a zero offset. A count is output for packet fragments but no errors are reported. First fragments have the UDP header included in the count. Middle and last fragments have only data included in the count (there is no UDP header).
- Byte 24 = 0x11 for UDP protocol.
- Received packet UDP checksum of zero means that there is no IPV4 checksum sent with the packet so no error will be issued.
- Received packet UDP checksum of 0xFFFF means that the checksum was calculated to be 0xFFFF or 0x0000 but was sent in the transmitted packet as 0xFFFF by the sending originating entity.

13.2.1.4.8.4.1.2 IPV4 TCP

- Byte 15 Upper Nibble = 4 for IPV4
- Byte 15 Lower Nibble = IHL - Nibble with number of 32-bit words in IPV4 header (5 to 15 supported).
- Bytes 20-21 = fragment[15-0] – Bit 13 is the MF bit and bits [12-0] are the Fragment offset. A packet is a fragment if the MF bit is set or if the fragment offset is non-zero. The first packet fragment has MF=1 with a zero offset. Middle fragments have MF=1 with a nonzero offset. The last packet fragment has MF=0 with a nonzero offset. Non-fragmented packets have MF=0 and a zero offset. A count is output for packet fragments but no errors are reported. First fragments have the UDP header included in the count. Middle and last fragments have only data included in the count (there is no TCP header).
- Byte 24 = 0x06 for TCP protocol.

13.2.1.4.8.4.1.3 IPV6 UDP

- Byte 15 upper nibble = 6 for IPV6.
- Byte 21 = 0x11 for UDP protocol as next header.
- Fragment extension headers are supported. First fragments have a fragment extension header (byte 21 = 0x2C) followed by a UDP header (byte 55 = 0x11). Middle and last fragments have a fragment extension header followed by data only (no UDP header). The first packet fragment has MF=1 with a zero offset. Middle fragments have MF=1 with a nonzero offset. The last packet fragment has MF=0 with a nonzero offset. Non-fragmented packets do not have a fragment extension header. A count is output for packet fragments but no errors are reported.
- Received packet UDP checksum of zero means that there is no IPV6 checksum sent with the packet so no error will be issued.

- Received packet UDP checksum of 0xFFFF means that the checksum was calculated to be 0xFFFF or 0x0000 but was sent in the transmitted packet as 0xFFFF by the sending originating entity.

13.2.1.4.8.4.1.4 IPV6 TCP

- Byte 15 upper nibble = 6 for IPV6.
- Byte 21 = 0x06 for TCP protocol as next header.
- Fragment extension headers are supported. First fragments have a fragment extension header (byte 21 = 0x2C) followed by a UDP header (byte 55 = 0x06). Middle and last fragments have a fragment extension header followed by data only (no TCP header). The first packet fragment has MF=1 with a zero offset. Middle fragments have MF=1 with a nonzero offset. The last packet fragment has MF=0 with a nonzero offset. Non-fragmented packets do not have a fragment extension header. A count is output for packet fragments but no errors are reported.

13.2.1.4.8.5 CPPI Receive Checksum Offload

Packets sent from host port 0 (switch ingress) to any Ethernet port can have a checksum calculated and inserted into the Ethernet egress packet. The RX_CHECKSUM_EN bit in the CPSW_P0_CONTROL_REG register must be set for receive checksum operation to be enabled. When bit RX_CHECKSUM_EN is enabled, Control Data Word 2 input on CPPI receive PSI interface determines how the checksum is calculated. The CHECKSUM_RESULT field in Control Data Word 2 determines where the checksum is inserted. The checksum result location is adjusted by the egress port if a VLAN is to be inserted or removed on Ethernet port egress.

13.2.1.4.8.6 Egress Packet Operations

Each CPSW egress port (Ethernet and Host) is capable of performing egress packet processing operations (CPSW_ALE_EGRESSOP). IntraVLAN processing either adds, removes, or replaces VLAN information or does nothing. InterVLAN routing allows hardware routing between a limited number of VLANs - thereby allowing high-bandwidth or other routing operations to be offloaded from software to the CPSW (hardware). IntraVLAN processing and InterVLAN routing operations are mutually exclusive. In addition, the packet source and destination addresses can be swapped on egress to facilitate OAM or generic testing operations.

13.2.1.4.9 MII Management Interface (MDIO)

The MII Management interface module implements the 802.3 serial management interface to interrogate and control external Ethernet PHY using a two-wire bus.

13.2.1.4.9.1 MDIO Frame Formats

Table 13-155 shows the address, Table 13-156 shows the read format and Table 13-157 shows the write format of the supported Clause 45 MII Management interface frames. Post-increment accesses are not supported.

Table 13-155. MDIO Clause 45 Address Frame Format

Pre-amble	Start Delimiter	Operation Code	PHY Address	MMD Number	Turnaround	Data
FFFF FFFFh	00	00	AAAAA	RRRRR	10	AAAA.AAAA.AAAA.AAAA

Table 13-156. MDIO Clause 45 Read Frame Format

Pre-amble	Start Delimiter	Operation Code	PHY Address	MMD Number	Turnaround	Data
FFFF FFFFh	00	11	AAAAA	RRRRR	Z0	DDDD.DDDD.DDDD.DDDD

Table 13-157. MDIO Clause 45 Write Frame Format

Pre-amble	Start Delimiter	Operation Code	PHY Address	MMD Number	Turnaround	Data
FFFF FFFFh	00	01	AAAAA	RRRRR	10	DDDD.DDDD.DDDD.DDDD

The default or idle state of the two wire serial interface is a logic one. All tri-state drivers should be disabled and the PHY's pull-up resistor will pull the MDIO line to a logic 1. Prior to initiating any other transaction, the station management entity shall send a preamble sequence of 32 contiguous logic 1 bits on the MDIO line with 32 corresponding cycles on MDCLK to provide the PHY with a pattern that it can use to establish synchronization. A PHY shall observe a sequence of 32 contiguous logic one bits on MDIO with 32 corresponding MDCLK cycles before it responds to any other transaction. The MDIO CPSW_MDIO_USER_ADDR0_REG register must be written before a read or write operation is performed to set the address used in the operation. Each read or write operation has a preceding address frame.

Preamble

The start of a frame is indicated by a preamble, which consists of a sequence of 32 contiguous bits all of which are a 1. This sequence provides the PHY a pattern to use to establish synchronization. The preamble is required in clause 45 operation.

Start Delimiter

The preamble is followed by the start delimiter which is indicated by a 00 pattern.

Operation Code

The operation code for an address transaction is 00. The operation code for a read is 11, while the operation code for a write is a 01.

PHY Address

The PHY address is 5 bits allowing 32 unique values. The first bit transmitted is the MSB of the PHY address.

MMD Number

The MMD number is the 5 bits allowing 32 unique values. The first bit transmitted is the MSB.

Turnaround

An idle bit time during which no device actively drives the MDIO signal shall be inserted between the register address field and the data field of a read frame in order to avoid contention. During a read frame, the PHY shall drive a zero bit onto MDIO for the first bit time following the idle bit and preceding the Data field. During a write frame, this field shall consist of a one bit followed by a zero bit.

Address

The address field is 16 bits on address operations. The first bit transmitted is the MSB of the address word. Each read/write operation initiated has an automatic address operation initiated first that uses the MDIO CPSW_MDIO_USER_ADDR0_REG/ CPSW_MDIO_USER_ADDR1_REG register values as the 16-bit address.

Data

The Data field is 16 bits on read and write operations. The first bit transmitted and received is the MSB of the data word.

13.2.1.4.9.2 MDIO Functional Description

The MII Management I/F will remain idle until enabled by setting the ENABLE bit in the CPSW_MDIO_CONTROL_REG register. The MII Management I/F will then continuously poll the link status from within the Generic Status Register of all possible 32 PHY addresses in turn recording the results in the MDIO CPSW_MDIO_LINK_REG register. Individual PHY's can be enabled or disabled for polling the associated bit in the CPSW_MDIO_POLL_EN_REG register. The CPSW_MDIO_LINK_REG and CPSW_MDIO_ALIVE_REG register bit values are updated on the poll of each PHY. The LINKSEL bit in the CPSW_MDIO_USER_PHY_SEL_REG_k register determines the status input that is used. A change in the link status of the two PHYs being monitored will set the appropriate bit in the MDIO CPSW_MDIO_LINK_INT_RAW_REG register and the MDIO CPSW_MDIO_LINK_INT_MASKED_REG register, if enabled by the LINKINT_ENABLE bit in the CPSW_MDIO_USER_PHY_SEL_REG_k register.

The MDIO CPSW_MDIO_ALIVE_REG register is updated by the MII Management I/F module if the PHY acknowledged the read of the generic status register. In addition, any PHY register read transactions initiated by the host also cause the MDIO CPSW_MDIO_ALIVE_REG register to be updated.

At any time, the host can define a transaction for the MII Management interface module to undertake using the DATA, PHYADR, REGADR, and WRITE fields in a CPSW_MDIO_USER_ACCESS_REG_k register. When the host sets the GO bit in this register, the MII Management interface module will begin the transaction without any further intervention from the host. Upon completion, the MII Management interface will clear the GO bit and set the USERINTRAW field in the CPSW_MDIO_USER_INT_RAW_REG register corresponding to the CPSW_MDIO_USER_ACCESS_REG_k register being used. The corresponding bit in the CPSW_MDIO_USER_INT_MASKED_REG register may also be set depending on the mask setting in the MDIO CPSW_MDIO_USER_INT_MASK_SET_REG and CPSW_MDIO_USER_INT_MASK_CLEAR_REG registers. A round-robin arbitration scheme is used to schedule transactions that may be queued by the host in different CPSW_MDIO_USER_ACCESS_REG_k registers. The host should check the status of the GO bit in the MDIO CPSW_MDIO_USER_ACCESS_REG_k register before initiating a new transaction to ensure that the previous transaction has completed. The host can use the ACK bit in the MDIO CPSW_MDIO_USER_ACCESS_REG_k register to determine the status of a read transaction.

It is necessary for software to use the MII Management interface module to setup the auto-negotiation parameters of each PHY attached to a MAC port, retrieve the negotiation results, and setup the CPSW_PN_MAC_CONTROL_REG register in the corresponding MAC.

13.2.1.5 CPSW0 Programming Guide

13.2.1.5.1 Initialization and Configuration of CPSW Subsystem

To configure the CPSW Ethernet Subsystem for operation, the host must perform the following:

1. Select the Interface (RMII, or RGMII) Mode. See the CTRLMMR_ENET1_CTRL and CTRLMMR_ENET2_CTRL[2-0] PORT_MODE_SEL fields.
2. Configure pads (pin muxing), as per the interface selected. Refer to , *Pad Configuration Registers* and the device-specific Datasheet.
3. Enable the CPSW Ethernet Subsystem clocks. See [Section 13.2.1.3 CPSW Integration](#)
4. Ensure that at least 2000 CPPI_ICLK periods are run after reset is de-asserted.
5. Configure the CPSW_CONTROL_REG register
6. Configure the Ethernet Port Source Address registers (CPSW_PN_SA_L_REG_k and CPSW_PN_SA_H_REG_k)

7. Configure the CPSW statistic port enable register CPSW_STAT_PORT_EN_REG
8. Configure the ALE ([Section 13.2.1.4.6.1, Address Lookup Engine](#))
9. Configure the MDIO ([Section 13.2.1.5.5.1, Initializing the MDIO Module](#))
10. Configure Ethernet port, as per the desired mode of operations

13.2.1.5.2 Transmit Operation

After reset, the host must write zeroes to all TX DMA State head descriptor pointers. The TX port may then be enabled. To initiate packet transmission the host constructs transmit queues in memory (one or more packets for transmission) and then writes the appropriate TX DMA state head descriptor pointers. For each buffer added to a transmit queue, the host must initialize the TX buffer descriptor values as follows:

1. Write the Next Descriptor Pointer with the 32-bit aligned address of the next descriptor in the queue (zero if last descriptor)
2. Write the Buffer Pointer with the byte aligned address of the buffer data
3. Write the Buffer Length with the number of bytes in the buffer
4. Write the Buffer Offset with the number of bytes in the offset to the data (nonzero with SOP only)
5. Set the SOP, EOP, and Ownership bits as appropriate
6. Clear the End Of Queue bit

The port begins TX packet transmission on a given channel when the host writes the channel's TX queue head descriptor pointer with the address of the first buffer descriptor in the queue (nonzero value). Each channel may have one or more queues, so each channel may have one or more head descriptor pointers. The first buffer descriptor for each TX packet must have the Start of Packet (SOP) bit and the Ownership bit set to one by the host. The last buffer descriptor for each TX packet must have the End of Packet (EOP) bit set to one by the host. The port will transmit packets until all queued packets have been transmitted and the queue(s) are empty. When each packet transmission is complete, the port will clear the Ownership bit in the packet's SOP buffer descriptor and issue an interrupt to the host by writing the packet's last buffer descriptor address to the queue's TX DMA State Completion Pointer. The interrupt is generated by the write, regardless of the value written. When the last packet in a queue has been transmitted, the port sets the End Of Queue bit in the EOP buffer descriptor, clears the Ownership bit in the SOP Descriptor, zeroes the appropriate DMA state head descriptor pointer, and then issues a TX interrupt to the host by writing to the queue's associated TX completion pointer (address of the last buffer descriptor processed by the port). The port issues a maskable level interrupt (which may then be routed through external interrupt control logic to the host).

On interrupt from the port, the host processes the buffer queue, detecting transmitted packets by the status of the Ownership bit in the SOP buffer descriptor. If the Ownership bit is cleared to zero, then the packet has been transmitted and the host may reclaim the buffers associated with the packet. The host continues queue processing until the end of the queue or until a SOP buffer descriptor is read that contains a set Ownership bit indicating that the packet transmission is not complete. The host determines that all packets in the queue have been transmitted when the last packet in the queue has a cleared Ownership bit in the SOP buffer descriptor, the End of Queue bit is set in the last packet EOP buffer descriptor, and the Next Descriptor Pointer of the last packet EOP buffer descriptor is zero. The host acknowledges an interrupt by writing the address of the last buffer descriptor to the queue's associated TX Completion Pointer in the TX DMA State. If the host written buffer address value is different from the buffer address written by the port, then the level interrupt remains asserted. If the host written buffer address value is equal to the port written value, then the level interrupt is de-asserted. The port write to the completion pointer actually stores the value in the state register (RAM). The host written value is actually not written to the register location. The host written value is compared to the register contents (which was written by the port) and if the two values are equal, the interrupt is removed, otherwise the interrupt remains asserted. The host may process multiple packets previous to acknowledging an interrupt, or the host may acknowledge interrupts for every packet.

A mis-queued packet condition may occur when the host adds a packet to a queue for transmission as the port finishes transmitting the previous last packet in the queue. The mis-queued packet is detected by the host when queue processing detects a cleared Ownership bit in the SOP buffer descriptor, a set End of Queue bit in the EOP buffer descriptor, and a nonzero Next Descriptor Pointer in the EOP buffer descriptor. A mis-queued packet means that the port read the last EOP buffer descriptor before the host added the new last packet to the queue, so the port determined queue empty just before the last packet was added. The host corrects the mis-queued

packet condition by initiating a new packet transfer for the mis-queued packet by writing the mis-queued packet's SOP buffer descriptor address to the appropriate DMA State TX Queue head Descriptor Pointer.

The host may add packets to the tail end of an active TX queue at any time by writing the Next Descriptor Pointer to the current last descriptor in the queue. If a TX queue is empty (inactive), the host may initiate packet transmission at any time by writing the appropriate TX DMA State head descriptor pointer. The host software should always check for and reinitiate transmission for mis-queued packets during queue processing on interrupt from the port. In order to preclude software underrun, the host should avoid adding buffers to an active queue for any TX packet that is not complete and ready for transmission.

The port determines that a packet is the last packet in the queue by detecting the End of Packet bit set with a zero Next Descriptor Pointer in the packet buffer descriptor. If the End of Packet bit is set and the Next Descriptor Pointer is nonzero, then the queue still contains one or more packets to be transmitted. If the EOP bit is set with a zero Next Descriptor Pointer, then the port will set the EOQ bit in the packet's EOP buffer descriptor and then zero the appropriate head descriptor pointer previous to interrupting the port (by writing the completion pointer) when the packet transmission is complete.

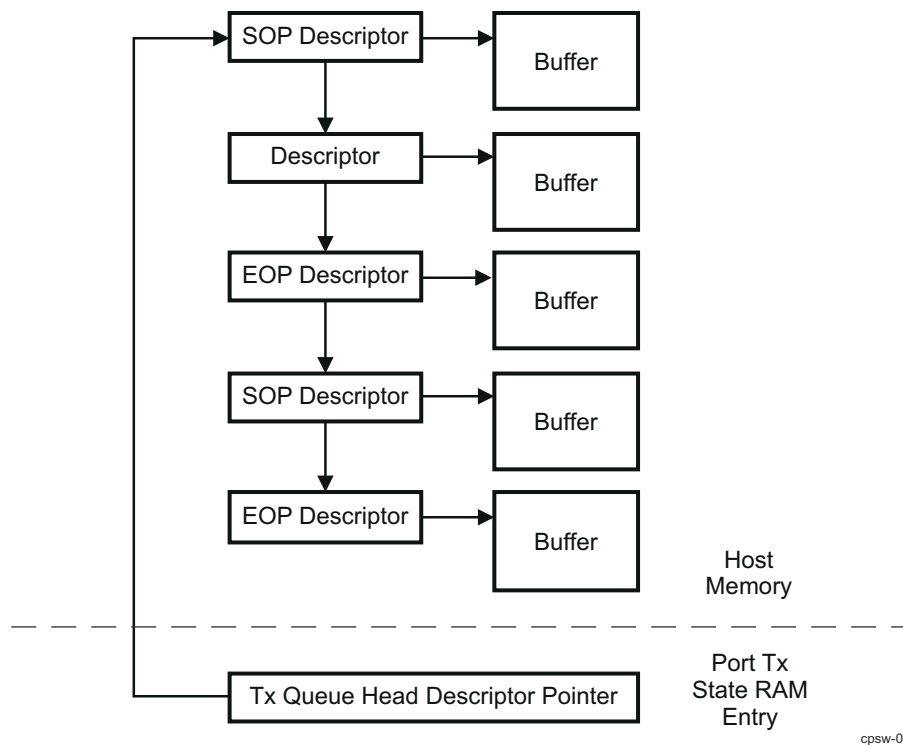

cpsw-016

Figure 13-123. TX Queue Head Descriptor

13.2.1.5.3 Receive Operation

After reset, the host must write zeroes to all RX DMA State head descriptor pointers. The RX port may then be enabled. To initiate packet reception, the host constructs receive queues in memory and then writes the appropriate RX DMA state head descriptor pointer. For each RX buffer descriptor added to the queue, the host must initialize the RX buffer descriptor values as follows:

1. Write the Next Descriptor Pointer with the 32-bit aligned address of the next descriptor in the queue (zero if last descriptor)
2. Write the Buffer Pointer with the byte aligned address of the buffer data
3. Clear the Offset field
4. Write the Buffer Length with the number of bytes in the buffer
5. Clear the SOP, EOP, and EOQ bits

6. Set the Ownership bit

The host enables packet reception on a given channel by writing the address of the first buffer descriptor in the queue (nonzero value) to the channel's head descriptor pointer in the channel's RX DMA state. When packet reception begins on a given channel, the port fills each RX buffer with data in order starting with the first buffer and proceeding through the RX queue. If the Buffer Offset in the RX DMA State is nonzero, then the port will begin writing data after the offset number of bytes in the SOP buffer. The port performs the following operations at the end of each packet reception:

1. Overwrite the buffer length in the packet's EOP buffer descriptor with the number of bytes actually received in the packet's last buffer. The host initialized value is the buffer size. The overwritten value will be less than or equal to the host initialized value.
2. Set the EOP bit in the packet's EOP buffer descriptor.
3. Set the EOQ bit in the packet's EOP buffer descriptor if the current packet is the last packet in the queue.
4. Overwrite the packet's SOP buffer descriptor Buffer Offset with the RX DMA state value (the host initialized the buffer descriptor Buffer Offset value to zero). All non SOP buffer descriptors must have a zero Buffer Offset initialized by the host.
5. Overwrite the packet's SOP buffer descriptor buffer length with the number of valid data bytes in the buffer. If the buffer is filled up, the buffer length will be the buffer size minus buffer offset.
6. Set the SOP bit in the packet's SOP buffer descriptor.
7. Write the SOP buffer descriptor Packet Length field.
8. Clear the Ownership bit in the packet's SOP buffer descriptor.
9. Issue an RX host interrupt by writing the address of the packet's last buffer descriptor to the queue's RX DMA State Completion Pointer. The interrupt is generated by the write to the RX DMA State Completion Pointer address location, regardless of the value written.

On interrupt the host processes the RX buffer queue detecting received packets by the status of the Ownership bit in each packet's SOP buffer descriptor. If the Ownership bit is cleared then the packet has been completely received and is available to be processed by the host. The host may continue RX queue processing until the end of the queue or until a buffer descriptor is read that contains a set Ownership bit indicating that the next packet's reception is not complete. The host determines that the RX queue is empty when the last packet in the queue has a cleared Ownership bit in the SOP buffer descriptor, a set End of Queue bit in the EOP buffer descriptor, and the Next Descriptor Pointer in the EOP buffer descriptor is zero.

A mis-queued buffer may occur when the host adds buffers to a queue as the port finishes the reception of the previous last packet in the queue. The mis-queued buffer is detected by the host when queue processing detects a cleared Ownership bit in the SOP buffer descriptor, a set End of Queue bit in the EOP buffer descriptor, and a nonzero Next Descriptor Pointer in the EOP buffer descriptor. A mis-queued buffer means that the port read the last EOP buffer descriptor before the host added buffer descriptor(s) to the queue, so the port determined queue empty just before the host added more buffer descriptor(s). In the transmit case, the packet transmission is delayed by the time required for the host to determine the condition and reinitiate the transaction, but the packet is not actually lost. In the receive case, receive overrun condition may occur in the mis-queued buffer case. If a new packet reception is begun during the time that the port has determined the end of queue condition, then the received packet will overrun (start of packet overrun). If the mis-queued buffer occurs during the middle of a packet reception then middle of packet overrun may occur. If the mis-queued buffer occurs after the last packet has completed, and is corrected before the next packet reception begins, then overrun will not occur. The host acts on the mis-queued buffer condition by writing the added buffer descriptor address to the appropriate RX DMA State Head Descriptor Pointer.

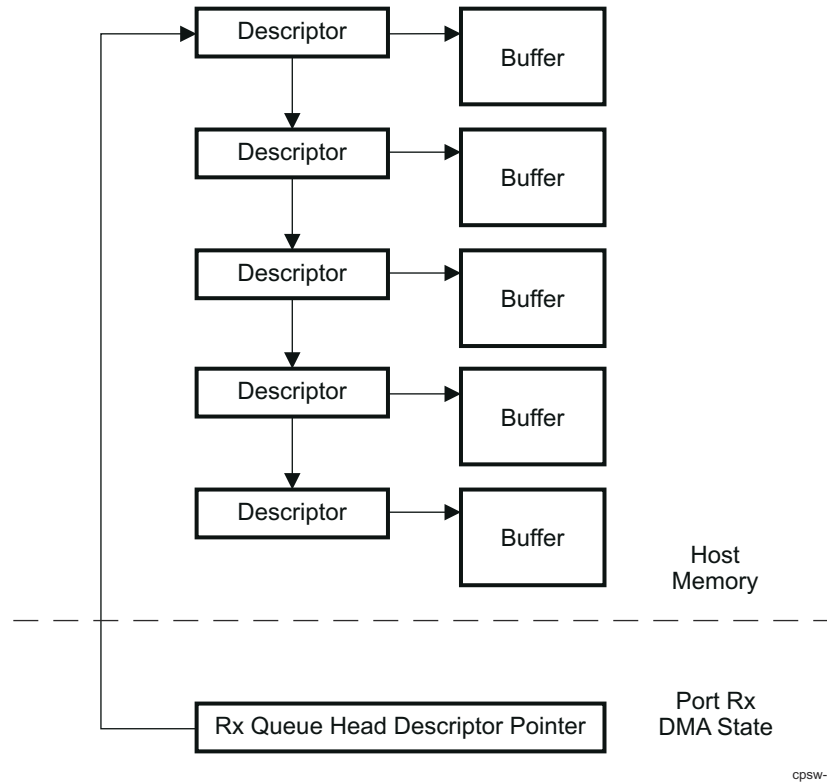

cpsw-017

Figure 13-124. RX Queue Head Descriptor

13.2.1.5.4 CPSW Reset

To reset the Ethernet port, the host must perform the following:

1. Set CMD_IDLE bit to 1h in the Ethernet port control register: CPSW_PN_MAC_CONTROL_REG.
2. Wait for IDLE bit to be set to 1h, which is indicated in the Ethernet port status register: CPSW_PN_MAC_STATUS_REG.
3. Set SOFT_RESET bit to 1h in the Ethernet port software reset register: CPSW_PN_MAC_SOFT_RESET_REG.
4. Wait for SOFT_RESET bit in the CPSW_PN_MAC_SOFT_RESET_REG registers to be cleared to confirm reset completion.
5. Configure the Ethernet ports.
6. Re-configure registers reset to default value by CPSW_PN_MAC_SOFT_RESET_REG.

13.2.1.5.5 MDIO Software Interface

13.2.1.5.5.1 Initializing the MDIO Module

The following steps are performed by the application software or device driver to initialize the MDIO device:

1. Configure the PREAMBLE and CLKDIV bits in the MDIO Control register (CPSW_MDIO_CONTROL_REG).
2. Enable the MDIO module by setting the ENABLE bit in CPSW_MDIO_CONTROL_REG.
3. The MDIO PHY alive status register (MDIO CPSW_MDIO_ALIVE_REG) can be read in polling fashion until a PHY connected to the system responded, and the MDIO PHY link status register (MDIO CPSW_MDIO_LINK_REG) can determine whether this PHY already has a link.
4. Set the appropriate PHY addresses in the MDIO user PHY select register (CPSW_MDIO_USER_PHY_SEL_REG_k, where k = 0 or 1), and set the LINKINT_ENABLE bit to enable a link change event interrupt if desirable.
5. Set the appropriate LINKSEL bit in the CPSW_MDIO_USER_PHY_SEL_REG_k register (where k = 0 or 1).
6. Set the appropriate USERINTMASKSET bit field in the CPSW_MDIO_USER_INT_MASK_SET_REG register.

- If an interrupt on general MDIO register access is desired, set the corresponding bit in the MDIO user command complete interrupt mask set register (MDIO CPSW_MDIO_USER_INT_MASK_SET_REG) to use the MDIO user access register (MDIO CPSW_MDIO_USER_ACCESS_REG_k, where k = 0 or 1).

13.2.1.5.5.2 Writing Data To a PHY Register

The MDIO module includes a user access register (MDIO CPSW_MDIO_USER_ACCESS_REG_k, where k = 0 or 1) to directly access a specified PHY device. To write a PHY register, perform the following:

- Check to ensure that the GO bit in the MDIO user access register (MDIO CPSW_MDIO_USER_ACCESS_REG_k) is cleared.
- Write to the GO, WRITE, REGADR, PHYADR, and DATA bits in MDIO CPSW_MDIO_USER_ACCESS_REG_k corresponding to the PHY and PHY register SW wants to write.
- The write operation to the PHY is scheduled and completed by the MDIO module. Completion of the write operation can be determined by polling the GO bit in MDIO CPSW_MDIO_USER_ACCESS_REG_k for a 0.
- Completion of the operation sets the corresponding USERINTRAW bit (0 or 1) in the MDIO user command complete interrupt register (CPSW_MDIO_USER_INT_RAW_REG) corresponding to MDIO CPSW_MDIO_USER_ACCESS_REG_k used. If interrupts have been enabled on this bit using the MDIO user command complete interrupt mask set register (CPSW_MDIO_USER_INT_MASK_SET_REG), then the bit is also set in the MDIO user command complete interrupt register (CPSW_MDIO_USER_INT_MASKED_REG) and an interrupt is triggered on the host processor.

13.2.1.5.5.3 Reading Data From a PHY Register

The MDIO module includes a user access register (MDIO CPSW_MDIO_USER_ACCESS_REG_k, where k = 0 or 1) to directly access a specified PHY device. To read a PHY register, perform the following:

- Check to ensure that the GO bit in the MDIO user access register (CPSW_MDIO_USER_ACCESS_REG_k, where k = 0 or 1) is cleared.
- Write to the GO, REGADR, and PHYADR bits in the CPSW_MDIO_USER_ACCESS_REG_k register corresponding to the PHY and PHY register SW wants to read.
- The read data value is available in the DATA bit field in MDIO CPSW_MDIO_USER_ACCESS_REG_k register after the module completes the read operation on the serial bus. Completion of the read operation can be determined by polling the GO and ACK bits in CPSW_MDIO_USER_ACCESS_REG_k register. After the GO bit has cleared, the ACK bit is set on a successful read.
- Completion of the operation sets the corresponding USERINTRAW bit (0 or 1) in the MDIO user command complete interrupt register (CPSW_MDIO_USER_INT_RAW_REG) corresponding to MDIO CPSW_MDIO_USER_ACCESS_REG_k used. If interrupts have been enabled on this bit using the MDIO user command complete interrupt mask set register (CPSW_MDIO_USER_INT_MASK_SET_REG), then the bit is also set in the MDIO user command complete interrupt register (CPSW_MDIO_USER_INT_MASKED_REG) and an interrupt is triggered on the host processor.

13.3 Memory Interfaces

This section describes the memory interfaces in the device.



13.3.1 General-Purpose Memory Controller (GPMC)

This section describes the General-Purpose Memory Controller (GPMC) for the device.

13.3.1.1 GPMC Overview	1159
13.3.1.2 GPMC Environment	1161
13.3.1.3 GPMC Integration	1168
13.3.1.4 GPMC Functional Description	1169
13.3.1.5 GPMC Basic Programming Model	1252

13.3.1.1 GPMC Overview

The General-Purpose Memory Controller is a unified memory controller dedicated for interfacing with external memory devices like:

- Asynchronous SRAM-like memories and application-specific integrated circuit (ASIC) devices
- Asynchronous, synchronous, and page mode (available only in non-multiplexed mode) burst NOR flash devices
- NAND flash
- Pseudo-SRAM devices

Table 13-158 shows the GPMC module allocation within device domains.

Table 13-158. GPMC Module Allocation within Device Domains

Module Instance	Domain		
	WKUP	MCU	MAIN
GPMC0	-	-	✓

Figure 13-125 shows the GPMC0 module overview.

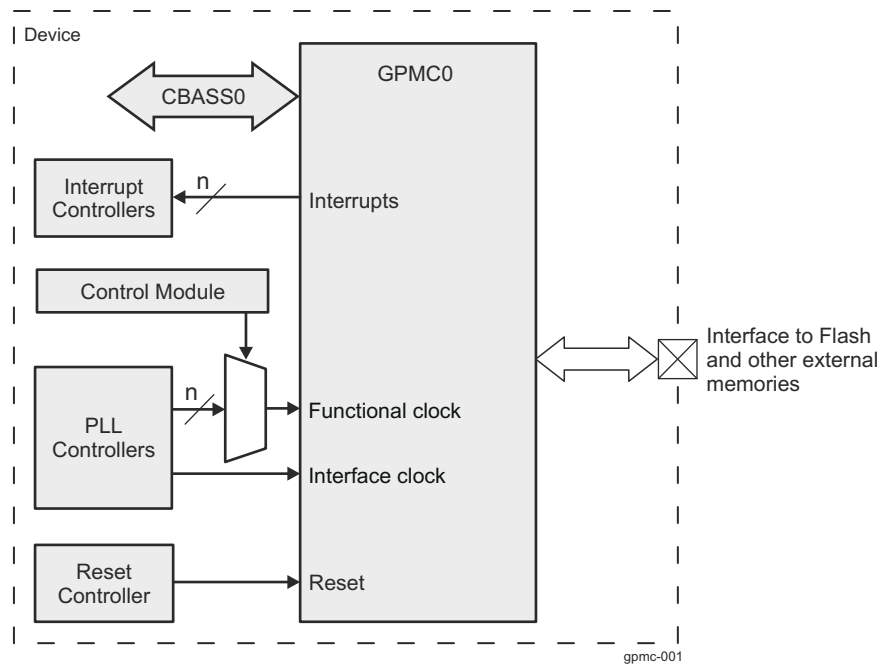

Figure 13-125. GPMC0 Overview

13.3.1.1.1 GPMC Features

The main features of the GPMC are:

- 8-, 16- or 32-bit-wide data path to external memory device
- Supports up to 4 chip select regions of programmable size and programmable base addresses in a total address space of 1GB
- Supports on-the-fly error code detection using the Bose-Chaudhuri-Hocquenghem (BCH) (t = 4, 8, or 16) or Hamming code to improve the reliability of NAND with a minimum effect on software (NAND flash with 512-byte page size or greater)
- Fully pipelined operation for optimal memory bandwidth usage
- The clock to the external memory is provided from GPMC_FCLK divided by 1, 2, 3, or 4
- Supports programmable autoclock gating when no access is detected

- Independent and programmable control signal timing parameters for setup and hold time on a per-chip basis. Parameters are set according to the memory device timing parameters with a timing granularity of one GPMC_FCLK clock cycle.
- Flexible internal access time control (wait state) and flexible handshake mode using external WAIT pin monitoring
- Support bus keeping
- Support bus turnaround
- Prefetch and write-posting engine associated with DMA controller at system level to achieve full performance from the NAND device with minimum effect on NOR/SRAM concurrent access
- 32-bit interconnect slave interface which supports non-wrapping and wrapping burst of up to 16x32 bits.

The GPMC supports the following various access types:

- Asynchronous read/write access
- Asynchronous read page access (4-8-16-32 Word16, 4-8-16 Word32)
- Synchronous read/write access
- Synchronous read/write burst access without wrap capability (4-8-16-32 Word16, 4-8-16 Word32)
- Synchronous read/write burst access with wrap capability (4-8-16-32 Word16, 4-8-16 Word32)
- Address-data-multiplexed (AD) access
- Address-address-data (AAD) multiplexed access
- Little-endian access only

The GPMC can communicate with a wide range of external devices:

- External asynchronous or synchronous 8-bit wide memory or device (non burst device)
- External asynchronous or synchronous 16-bit wide memory or device
- External asynchronous or synchronous 32-bit wide memory or device
- External 16-bit non-multiplexed NOR flash device
- External 16- and 32-bit address and data multiplexed NOR Flash device
- External 8-bit and 16-bit NAND flash device
- External 16-bit and 32-bit pseudo-SRAM (pSRAM) device

Note

Page mode is available only in non-multiplexed mode.

13.3.1.1.2 GPMC Not Supported Features

The following features are not supported on this family of devices:

- Asynchronous page write mode is not supported.
- Multiple write access in asynchronous mode is not supported.
- Multiple read access in asynchronous mode is not supported in address/data-multiplexed and AAD-multiplexed modes.

13.3.1.2 GPMC Environment

The GPMC0 module is hereinafter referred to as GPMC.

This section describes the GPMC0 external connections (environment).

13.3.1.2.1 GPMC Modes

This section shows four GPMC0 external connection options:

- [Figure 13-126](#) shows a connection between the GPMC0 and a 32-bit synchronous address/data-multiplexed external memory device.
- [Figure 13-127](#) shows a connection between the GPMC0 and a 16-bit synchronous address/data-multiplexed (or AAD-multiplexed but this protocol uses fewer address pins) external memory device.
- [Figure 13-128](#) shows a connection between the GPMC0 and a 16-bit synchronous non-multiplexed external memory device.
- [Figure 13-129](#) shows a connection between the GPMC0 and an 8-bit synchronous non-multiplexed external memory device.
- [Figure 13-130](#) shows a connection between the GPMC0 and an 8-bit NAND device.

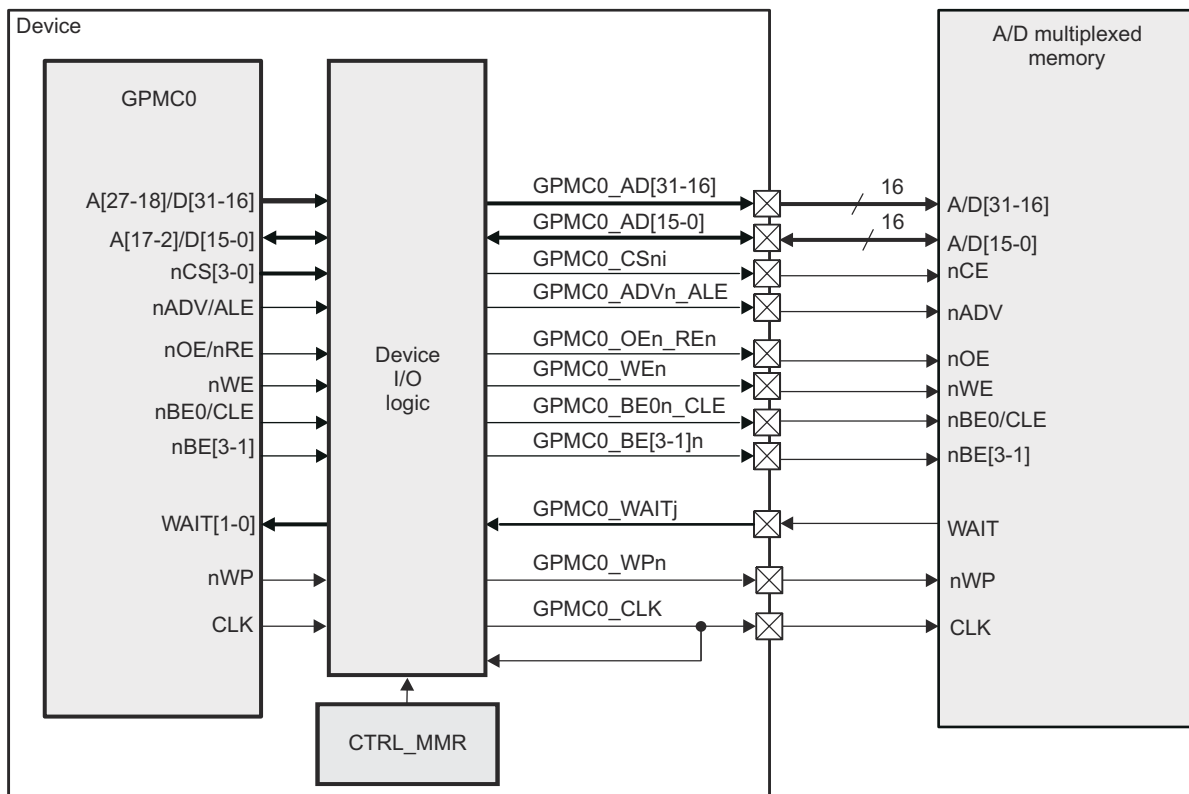

gpmc-002_32

i = 0 to 3
j = 0 to 1

Figure 13-126. GPMC to 32-Bit Address/Data-Multiplexed Memory

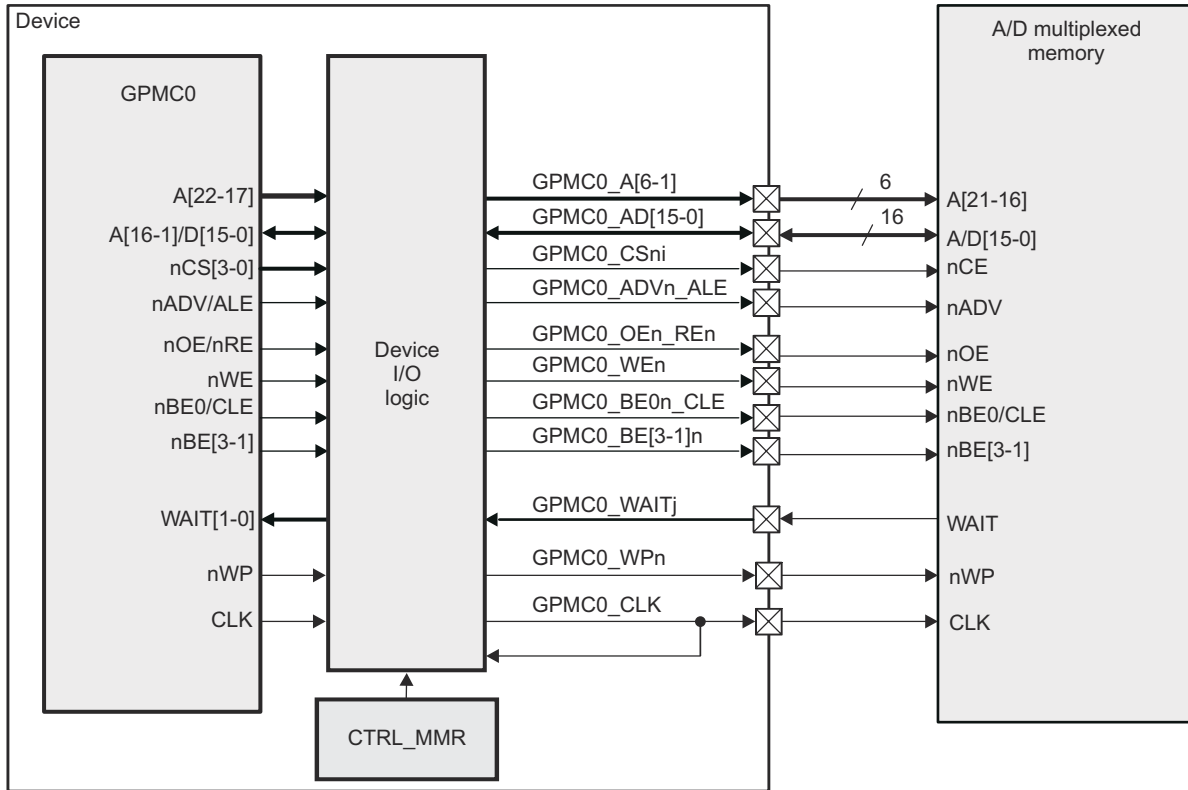

gpmc-002

i = 0 to 3
j = 0 to 1

Figure 13-127. GPMC to 16-Bit Address/Data-Multiplexed Memory

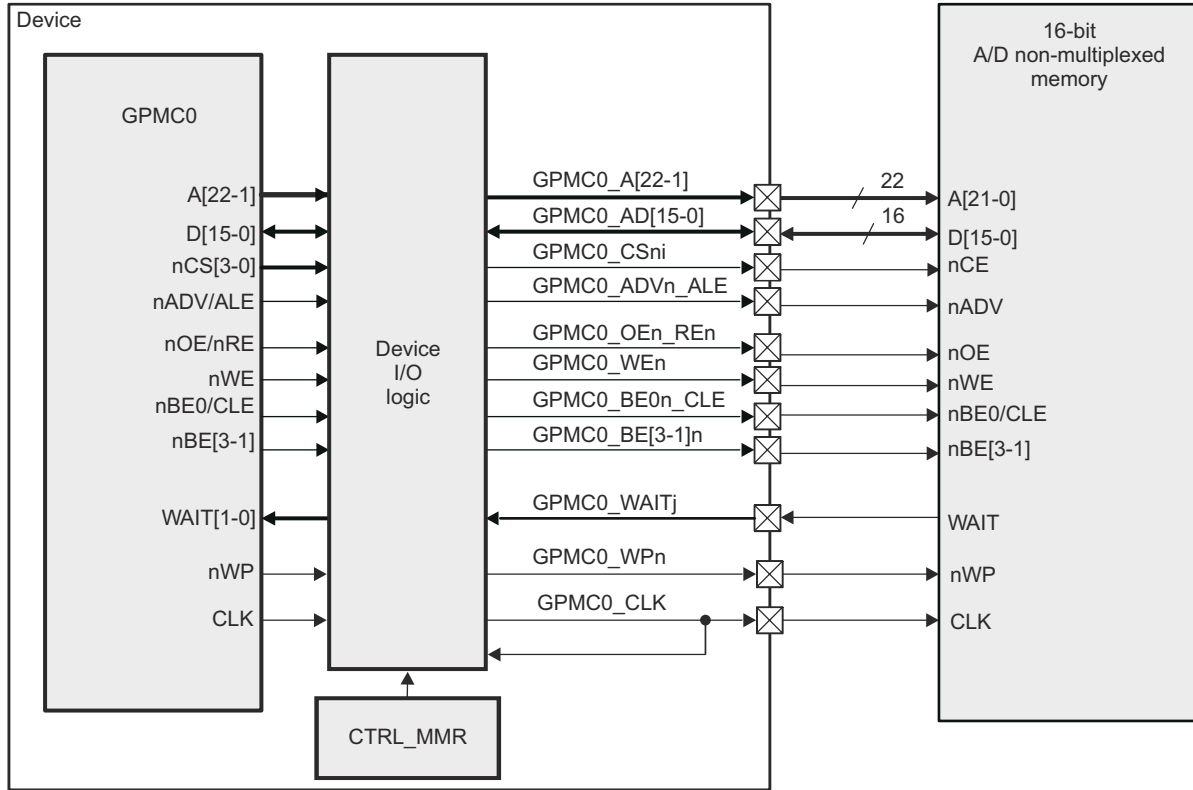

gpmc-045

i = 0 to 3
j = 0 to 1

Figure 13-128. GPMC to 16-Bit Non-Multiplexed Memory

ADVANCE INFORMATION

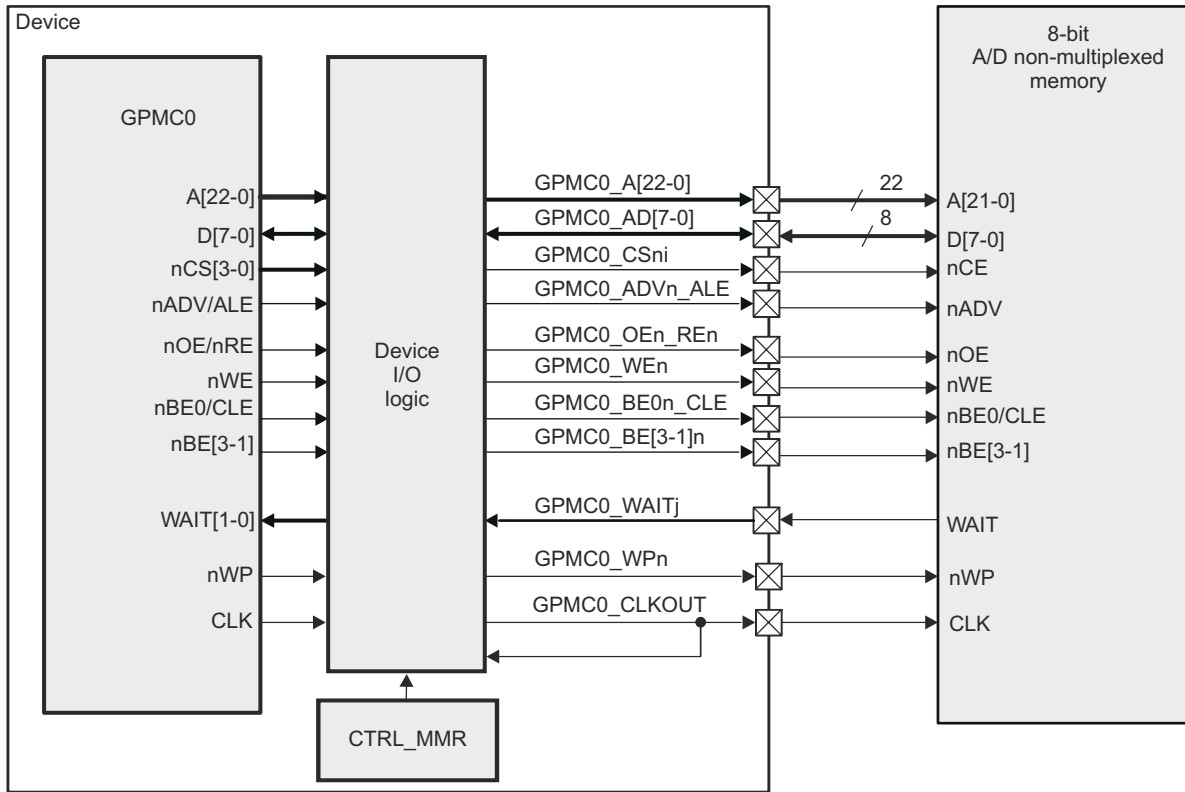

gpmc-045a

i = 0 to 3

j = 0 to 1

Figure 13-129. GPMC to 8-Bit Non-Multiplexed Memory

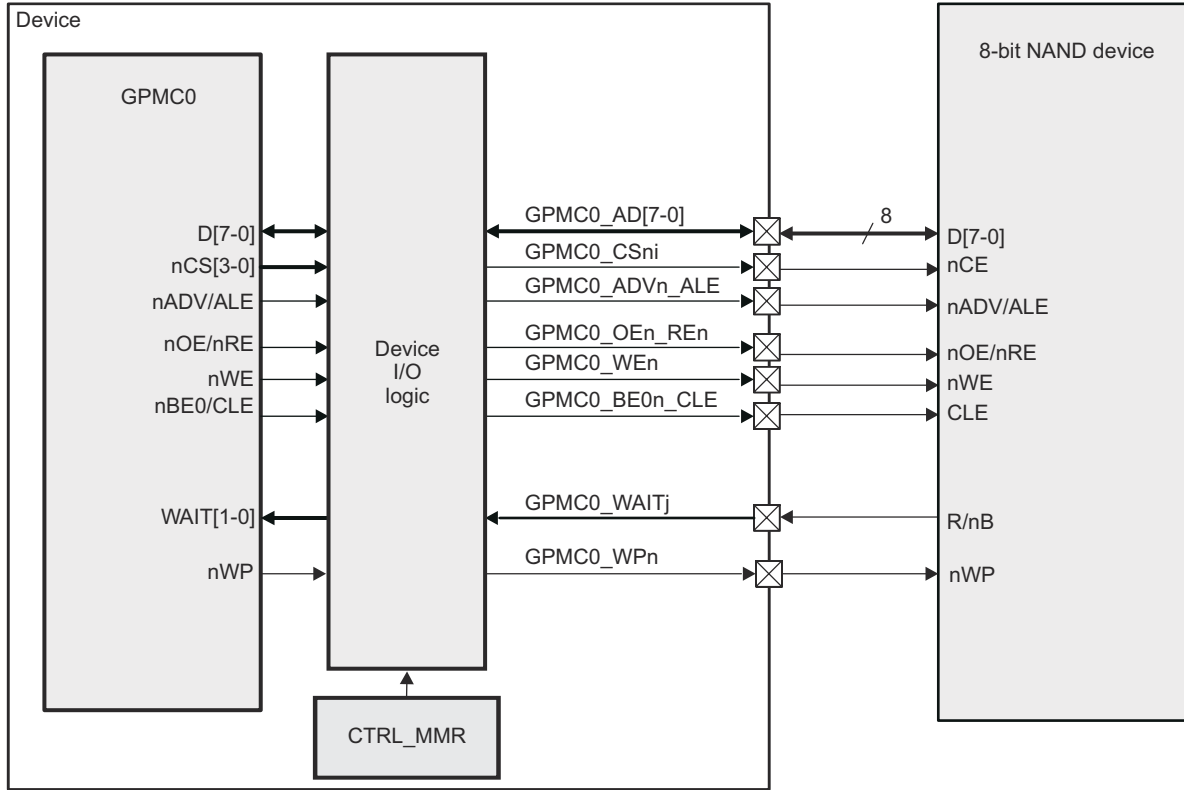

gpmc-003

i = 0 to 3
j = 0 to 1

Figure 13-130. GPMC to 8-Bit NAND Device

13.3.1.2.2 GPMC I/O Signals

Table 13-159 lists the GPMC subsystem input/output (I/O) pins.

Table 13-159. GPMC I/O Signals (Master Mode)

Module Pin	Device Level Signal	I/O ⁽¹⁾	Description	Module Pin Reset Value ⁽²⁾
GPMC0				
A[22-0]	GPMC0_A[22-0]	O	23-bit output address bus	-
A[27-2]/D[31-0]	GPMC0_AD[31-0]	I/O	Multiplexed address/data	-
nCS[3-0]	GPMC0_CS[3-0]	O	Chip-selects (active low)	-
CLK	GPMC0_CLK	O	Clock generated for the external memory or device. For more information, see .	-
CLKLB				
N/A	GPMC0_FCLK_MUX	O	Free running clock. GPMC functional clock (GPMC0_FCLK) propagated on a device pad. For more information on the GPMC0_FCLK_MUX integration, see .	-
nADV/ALE	GPMC0_ADVn_ALE	O	Address valid (active low). Also used as address latch enable (active high) for NAND protocol memories.	-
nOE/nRE	GPMC0_OEn_REn	O	Output enable (active low). Also used as read enable (active low) for NAND protocol memories.	-
nWE	GPMC0_WEn	O	Write enable (active low)	-
nBE0/CLE	GPMC0_BE0n_CLE	O	Lower-byte enable (active low). Also used as command latch enable for NAND protocol memories.	-
nBE[3-1]	GPMC0_BE[3-1]n	O	Upper-byte enable (active low)	-

Table 13-159. GPMC I/O Signals (Master Mode) (continued)

Module Pin	Device Level Signal	I/O ⁽¹⁾	Description	Module Pin Reset Value ⁽²⁾
WAIT[1-0]	GPMC0_WAIT[1-0]	I	External wait signal for NOR and NAND protocol memories. Can be mapped on any of the chip-selects.	-
nWP	GPMC0_WPn	O	Write protect (active low)	-
DIR	GPMC0_DIR	O	This signal can be used to control an external buffer direction. Also controls the signal direction of D[15-0]. Low during transmit (for write access: data OUT from GPMC0 to memory). High during receive (for read access: data IN from memory to GPMC0).	-

(1) I = Input; O = Output; I/O - Bidirectional

(2) HiZ = High Impedance

Note

For GPMC output clock signal (CLK) to work properly, the RXACTIVE bit of the appropriate CTRLMMR_PADCONFIGy registers should be set to 0x1 because of retiming purposes.

Note

For more information about device level signals (pull-up/down resistors, buffer type, multiplexing and others), see tables *Pin Attributes* and *Pin Multiplexing* in the device-specific Datasheet.

Table 13-160 shows the use of address and data GPMC pins based on the type of external device.

Table 13-160. GPMC Pin Multiplexing Options

GPMC Pin	Multiplexed Address Data 32-Bit Device	Multiplexed Address Data 16-Bit Device	non-multiplexed Address Data 16-Bit Device (incomplete 28-bit address range)	non-multiplexed Address Data 8-Bit Device (incomplete 28-bit address range)	16-Bit NAND Device	8-Bit NAND Device
GPMC0_A[22]	Not used	Not used	A22	A22	Not used	Not used
GPMC0_A[21]	Not used	Not used	A21	A21	Not used	Not used
GPMC0_A[20]	Not used	Not used	A20	A20	Not used	Not used
GPMC0_A[19]	Not used	Not used	A19	A19	Not used	Not used
GPMC0_A[18]	Not used	Not used	A18	A18	Not used	Not used
GPMC0_A[17]	Not used	Not used	A17	A17	Not used	Not used
GPMC0_A[16]	Not used	Not used	A16	A16	Not used	Not used
GPMC0_A[15]	Not used	Not used	A15	A15	Not used	Not used
GPMC0_A[14]	Not used	Not used	A14	A14	Not used	Not used
GPMC0_A[13]	Not used	Not used	A13	A13	Not used	Not used
GPMC0_A[12]	Not used	Not used	A12	A12	Not used	Not used
GPMC0_A[11]	Not used	Not used	A11	A11	Not used	Not used
GPMC0_A[10]	Not used	A26	A10	A10	Not used	Not used
GPMC0_A[9]	Not used	A25	A9	A9	Not used	Not used
GPMC0_A[8]	Not used	A24	A8	A8	Not used	Not used
GPMC0_A[7]	Not used	A23	A7	A7	Not used	Not used
GPMC0_A[6]	Not used	A22	A6	A6	Not used	Not used
GPMC0_A[5]	Not used	A21	A5	A5	Not used	Not used
GPMC0_A[4]	Not used	A20	A4	A4	Not used	Not used
GPMC0_A[3]	Not used	A19	A3	A3	Not used	Not used
GPMC0_A[2]	Not used	A18	A2	A2	Not used	Not used

Table 13-160. GPMC Pin Multiplexing Options (continued)

GPMC Pin	Multiplexed Address Data 32-Bit Device	Multiplexed Address Data 16-Bit Device	non-multiplexed Address Data 16-Bit Device (incomplete 28-bit address range)	non-multiplexed Address Data 8-Bit Device (incomplete 28-bit address range)	16-Bit NAND Device	8-Bit NAND Device
GPMC0_A[1]	Not used	A17	A1	A1	Not used	Not used
GPMC0_A[0] ⁽¹⁾	Not used	A0 - Not used	Not used	A0	Not used	Not used
GPMC0_AD[31]	D31	Not used	Not used	Not used	Not used	Not used
GPMC0_AD[30]	D30	Not used	Not used	Not used	Not used	Not used
GPMC0_AD[29]	D29	Not used	Not used	Not used	Not used	Not used
GPMC0_AD[28]	D28	Not used	Not used	Not used	Not used	Not used
GPMC0_AD[27]	D27	Not used	Not used	Not used	Not used	Not used
GPMC0_AD[26]	D26	Not used	Not used	Not used	Not used	Not used
GPMC0_AD[25]	A27/D25	Not used	Not used	Not used	Not used	Not used
GPMC0_AD[24]	A26/D24	Not used	Not used	Not used	Not used	Not used
GPMC0_AD[23]	A25/D23	Not used	Not used	Not used	Not used	Not used
GPMC0_AD[22]	A24/D22	Not used	Not used	Not used	Not used	Not used
GPMC0_AD[21]	A23/D21	Not used	Not used	Not used	Not used	Not used
GPMC0_AD[20]	A22/D20	Not used	Not used	Not used	Not used	Not used
GPMC0_AD[19]	A21/D19	Not used	Not used	Not used	Not used	Not used
GPMC0_AD[18]	A20/D18	Not used	Not used	Not used	Not used	Not used
GPMC0_AD[17]	A19/D17	Not used	Not used	Not used	Not used	Not used
GPMC0_AD[16]	A18/D16	Not used	Not used	Not used	Not used	Not used
GPMC0_AD[15]	A17/D15	A16/D15	D15	Not used	D15	Not used
GPMC0_AD[14]	A16/D14	A15/D14	D14	Not used	D14	Not used
GPMC0_AD[13]	A15/D13	A14/D13	D13	Not used	D13	Not used
GPMC0_AD[12]	A14/D12	A13/D12	D12	Not used	D12	Not used
GPMC0_AD[11]	A13/D11	A12/D11	D11	Not used	D11	Not used
GPMC0_AD[10]	A12/D10	A11/D10	D10	Not used	D10	Not used
GPMC0_AD[9]	A11/D9	A10/D9	D9	Not used	D9	Not used
GPMC0_AD[8]	A10/D8	A9/D8	D8	Not used	D8	Not used
GPMC0_AD[7]	A9/D7	A8/D7	D7	D7	D7	D7
GPMC0_AD[6]	A8/D6	A7/D6	D6	D6	D6	D6
GPMC0_AD[5]	A7/D5	A6/D5	D5	D5	D5	D5
GPMC0_AD[4]	A6/D4	A5/D4	D4	D4	D4	D4
GPMC0_AD[3]	A5/D3	A4/D3	D3	D3	D3	D3
GPMC0_AD[2]	A4/D2	A3/D2	D2	D2	D2	D2
GPMC0_AD[1]	A3/D1	A2/D1	D1	D1	D1	D1
GPMC0_AD[0]	A2/D0	A1/D0	D0	D0	D0	D0

(1) Used to effectively address 8-bit (only) non-multiplexed memories

With all device types, the GPMC does not drive unnecessary address lines. They stay at their reset value of 0x0.

Address mapping supports address/data-multiplexed 16- or 32-bit-wide devices:

- The NOR flash memory controller still supports non-multiplexed address and data memory devices.
- Multiplexing mode can be selected through the GPMC_CONFIG1_i[9-8] MUXADDDATA bit field (where i = 0 to 3).

13.3.1.3 GPMC Integration

This section describes module integration in the device, including information about clocks, resets, and hardware requests.

Note

This content is currently **under-construction** and subject to change prior to official device release.

13.3.1.4 GPMC Functional Description

The GPMC basic programming model offers maximum flexibility to support various access protocols for each of the four configurable chip-selects. Use optimal chip-select settings, based on the characteristics of the external device:

- Different protocols can be selected to support generic asynchronous or synchronous random-access devices (NOR flash, SRAM) or to support specific NAND devices.
- The address and data bus can be multiplexed on the same external bus.
- Read and write access can be independently defined as asynchronous or synchronous.
- System requests (byte, 16-bit word, burst) are performed through single or multiple accesses. External access profiles (single, multiple with optimized burst length, native- or emulated-wrap) are based on external device characteristics (supported protocol, bus width, data buffer size, native-wrap support).
- System burst read or write requests are synchronous-burst (multiple-read or multiple-write). When neither burst nor page mode is supported by external memory or ASIC devices, system burst read or write requests are translated to successive single synchronous or asynchronous accesses (single reads or single writes). 8-bit wide devices are supported only in single synchronous or single asynchronous read or write mode.
- To simulate a programmable internal-wait-state, an external WAIT pin can be monitored to dynamically control external access at the beginning (initial access time) of and during a burst access.

Each control signal is controlled independently for each chip-select. The internal functional clock of the GPMC (GPMC_FCLK) is used as a time reference to specify the following:

- Read- and write-access duration
- Most GPMC external interface control-signal assertion and deassertion times
- Data-capture time during read access
- External wait-pin monitoring time
- Duration of idle time between accesses, when required

13.3.1.4.1 GPMC Block Diagram

[Figure 13-131](#) shows the GPMC functional block diagram. The GPMC consists of six blocks:

- Interconnect port interface
- Address decoder, GPMC configuration, and chip-select configuration register file
- Access engine
- Prefetch and write-posting engine
- Error correction code engine (ECC)
- External device/memory port interface

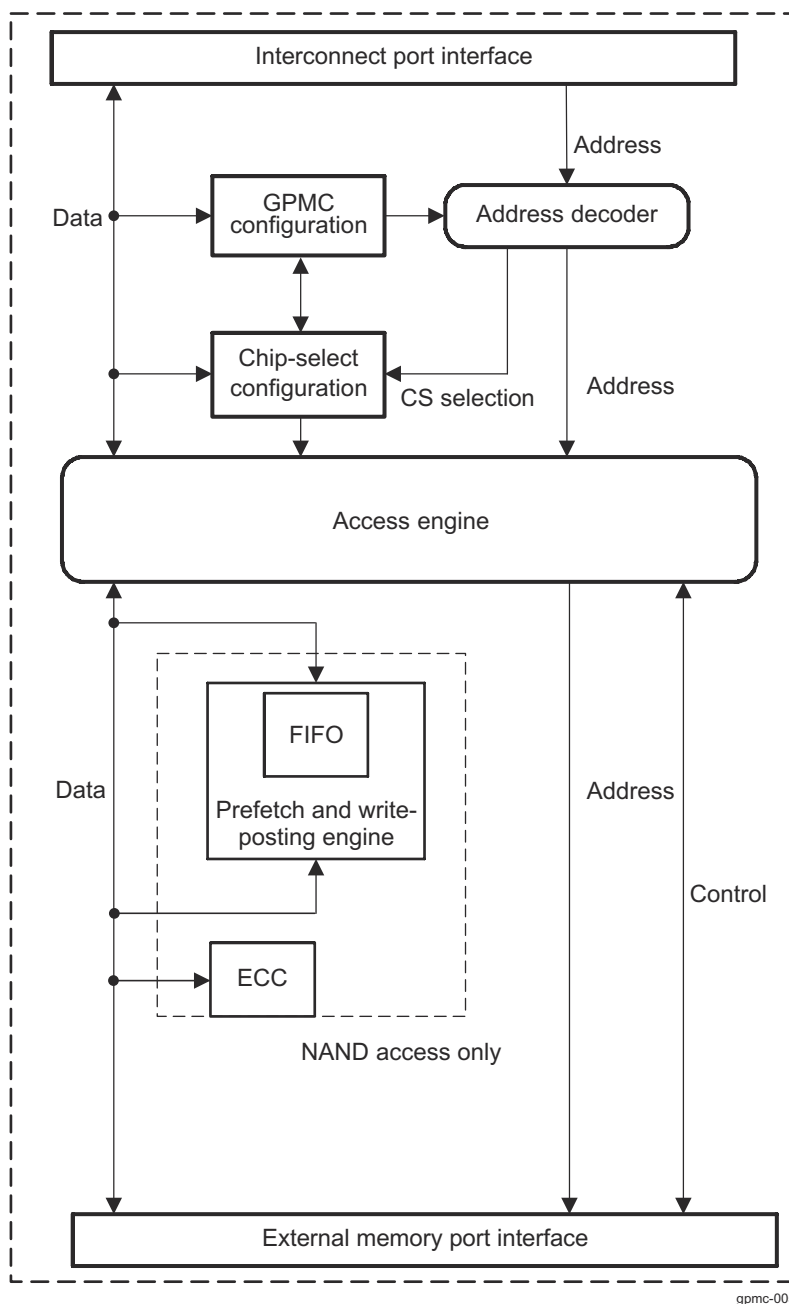

Figure 13-131. GPMC Block Diagram

The GPMC can access various external devices. The flexible programming model allows a wide range of attached device types and access schemes.

Based on the programmed configuration bit fields stored in the GPMC registers, the GPMC can generate the timing of all control signals depending on the attached device and access type.

Given the chip-select decoding and its associated configuration registers, the GPMC selects the appropriate control signal timing for the device type.

13.3.1.4.2 GPMC Clock Configuration

Table 13-161 describes the GPMC clocks.

Table 13-161. GPMC Clocks

Signal	I/O ⁽¹⁾	Description
GPMC_FCLK	I	Functional clock
GPMC_ICLK	I	Interface clock
CLK (GPMC_CLKOUT pin)	O	External clock provided to synchronous external memory devices and to DCC5 in the device.

(1) I = Input; O = Output; I/O - Bidirectional

The GPMC output clock (CLK) is generated by the GPMC from the internal GPMC_FCLK clock. The source of the GPMC_FCLK is described in . The GPMC output clock is configured using the GPMC_CONFIG1_i[1-0] GPMCFCLKDIVIDER bit field (where i = 0 to 3), as shown in [Table 13-162](#).

Table 13-162. GPMC Output Clock Configuration

Source Clock	GPMC_CONFIG1_i[1-0] GPMCFCLKDIVIDER	GPMC Output Clock Provided to External Memory Device
GPMC_FCLK	00	GPMC_FCLK
	01	GPMC_FCLK/2
	10	GPMC_FCLK/3
	11	GPMC_FCLK/4

When using synchronous interface protocols, the GPMC output clock (CLK), toggles only during the read or write access cycle. In some applications, it may be desirable to have a continuous clock running at the GPMC interface clock frequency for clocking attached devices. This option is enabled by an optional clock path from the GPMC functional clock input (GPMC_FCLK) to the GPMC_FCLK_MUX pin. This output clock, to GPMC_FCLK_MUX pin, can be selected through the standard MUXMODE selection of the GPMC_FCLK_MUX pin PADCONFIG control register.

Note that when using such synchronous interface protocols with the continuous clock option, user should ensure that the GPMC outputs are timed to the same frequency (GPMC_CONFIG1_i[1-0] GPMCFCLKDIVIDER = 0).

13.3.1.4.3 GPMC Power Management

[Table 13-163](#) describes the local power-management features available for the GPMC module.

Table 13-163. GPMC Local Power-Management Features

Feature	Registers	Description
Clock autogating	GPMC_SYSCONFIG[0] AUTOIDLE	This bit allows a local power optimization inside the module, by gating the GPMC_ICLK clock upon the internal activity.
Slave idle modes	GPMC_SYSCONFIG[4-3] SIDLEMODE	Force-idle, no-idle and smart-idle modes are available.

13.3.1.4.4 GPMC Interrupt Requests

The GPMC generates one interrupt request (see , *GPMC0 Hardware Requests*).

[Table 13-164](#) lists the event flags, and their mask, that can cause module interrupts.

Table 13-164. GPMC Interrupt Events

Event Flag	Event Mask	Sensitivity	Description
GPMC_IRQSTATUS[9] WAIT1EDGE DETECTIONSTATUS	GPMC_IRQENABLE[9] WAIT1EDGE DETECTIONENABLE	Edge	Wait1 edge detection interrupt: Triggered if a rising or falling edge is detected on the GPMC_WAIT1 signal. The rising or falling edge detection of Wait1 is selected through the GPMC_CONFIG[9] WAIT1PINPOLARITY bit.

Table 13-164. GPMC Interrupt Events (continued)

Event Flag	Event Mask	Sensitivity	Description
GPMC_IRQSTATUS[8] WAIT0EDGE DETECTIONSTATUS	GPMC_IRQENABLE[8] WAIT0EDGE DETECTIONENABLE	Edge	Wait0 edge detection interrupt: Triggered if a rising or falling edge is detected on the GPMC_WAIT0 signal. The rising or falling edge detection of Wait0 is selected through the GPMC_CONFIG[8] WAIT0PINPOLARITY bit.
GPMC_IRQSTATUS[1] TERMINAL COUNTSTATUS	GPMC_IRQENABLE[1] TERMINAL COUNTENABLE	Level	Terminal count event: Triggered on prefetch process completion; that is, when the number of currently remaining data to be requested reaches 0.
GPMC_IRQSTATUS[0] FIFOEVENTSTATUS	GPMC_IRQENABLE[0] FIFOEVENTENABLE	Level	FIFO event interrupt: Indicates available FIFO levels for write-posting mode and prefetch mode. GPMC_PREFETCH_CONFIG1[2] DMAMODE must be set to 0.

13.3.1.4.5 GPMC Interconnect Port Interface

Note

Some of the GPMC features described in this section may not be supported on this family of devices. For more information, see , *GPMC Not Supported Features*.

The GPMC interconnect interface is a pipelined interface including a 16 × 32-bit word write buffer.

Any system host can issue external access requests through the GPMC.

The device system can issue the following requests through this interface:

- One 8-, 16-, or 32-bit interconnect access (read/write)
- Two incrementing 32-bit interconnect accesses (read/write)
- Two wrapped 32-bit interconnect accesses (read/write)
- Four incrementing 32-bit interconnect accesses (read/write)
- Four wrapped 32-bit interconnect accesses (read/write)
- Eight incrementing 32-bit interconnect accesses (read/write)
- Eight wrapped 32-bit interconnect accesses (read/write)

Only linear burst transactions are supported; interleaved burst transactions are not supported. Only power-of-two-length precise bursts 2 × 32, 4 × 32, 8 × 32, and 16 × 32, with the burst base address aligned on the total burst size, are supported (this limitation applies to incrementing bursts only).

This interface also provides one interrupt and one DMA request line for specific event control.

It is recommended to program the GPMC_CONFIG1_i[24-23] ATTACHEDDEVICEPAGELENGTH bit field according to the page length of the effective attached device and to enable the GPMC_CONFIG1_i[31] WRAPBURST bit if the attached device supports wrapping burst.

It is possible, however, to emulate wrapping burst on a nonwrapping memory by providing relevant addresses within the page or by splitting transactions. Bursts larger than the memory page length are chopped into multiple burst transactions. Because of the alignment requirements, a page boundary is never crossed.

13.3.1.4.6 GPMC Address and Data Bus

The current application supports GPMC connection to NAND devices and to address/data-multiplexed memories or devices. Connection to address/data-non-multiplexed memories or devices is supported with an address range of 256MB.

Depending on the GPMC configuration of each chip-select, address and data bus lines that are not required for a particular access protocol are not updated (changed from current value) and are not sampled when input (input data bus).

- For address/data-multiplexed and AAD-multiplexed NOR devices, the address is multiplexed on the data bus.

- 8-bit-wide NOR devices do not use GPMC I/O: GPMC_AD[15-8] for data (they are used for address if needed).
- 16-bit-wide NAND devices do not use GPMC I/O: GPMC_A[22-0].
- 8-bit-wide NAND devices do not use GPMC I/O: GPMC_A[22-0] and GPMC I/O: GPMC_AD[15-8].

13.3.1.4.6.1 GPMC I/O Configuration Setting

Note

In this section and the following sections, the *i* in GPMC_CONFIGx_i stands for the GPMC chip-select *i*, where *i* = 0 to 3.

To select a NAND device, program the following register fields:

- GPMC_CONFIG1_i[11-10] DEVICETYPE = 0b10
- GPMC_CONFIG1_i[9-8] MUXADDDATA = 0b00

To select an address/data-multiplexed device, program the following register fields:

- GPMC_CONFIG1_i[11-10] DEVICETYPE = 0b00
- GPMC_CONFIG1_i[9-8] MUXADDDATA = 0b10

To select an address/address/data-multiplexed device, program the following register fields:

- GPMC_CONFIG1_i[11-10] DEVICETYPE = 0b00
- GPMC_CONFIG1_i[9-8] MUXADDDATA = 0b01

To select an address/data-non-multiplexed device, program the following register fields:

- GPMC_CONFIG1_i[11-10] DEVICETYPE = 0b00
- GPMC_CONFIG1_i[9-8] MUXADDDATA = 0b00

13.3.1.4.7 GPMC Address Decoder and Chip-Select Configuration

Addresses are decoded accordingly with the address request of the chip-select and the content of the chip-select base address register file, which includes a set of global GPMC configuration registers and four sets of chip-select configuration registers.

The GPMC configuration register file is memory-mapped and can be read or written with byte, 16-bit word, or 32-bit word accesses. The register file must be configured as a noncacheable, nonbufferable region to prevent any desynchronization between host execution (write request) and the completion of register configuration (write completed with register updated).

After the chip-select is configured, the access engine accesses the external device, drives the external interface control signals, and applies the interface protocol based on user-defined timing parameters and settings.

13.3.1.4.7.1 Chip-Select Base Address and Region Size

Any external memory or ASIC device attached to the GPMC external interface can be accessed by any device system host within the GPMC 128MB address space. For more information, see , *Memory Map*.

Note

Even though GPMC supports total address space of 1GB, only 128MB are physically available in this device.

The GPMC 128MB address space can be divided into a maximum of four chip-select regions with programmable base address and programmable chip-select size. The chip-select size is programmable from 16MB to 256MB (must be a power-of-two) and is defined by the mask field. Attached memory smaller than the programmed chip-select region size is accessed through the entire chip-select region (aliasing).

Each chip-select has a 6-bit base address encoding and 4-bit decoding mask, which must be programmed according to the following rules:

- The programmed chip-select region base address must be aligned on the chip-select region size address boundary and is limited to a power-of-two address value. During access decoding, the value of the register base address is used to compare the address with the address bit line mapping, as shown in Figure 13-132 (with A0 as the device system byte-address line). The base address is programmed through the GPMC_CONFIG7_i[5-0] BASEADDRESS bit field.
- The register mask is used to exclude some address lines from the decoding. A register mask bit field set to 0 suppresses the associated address line from the address comparison (incoming address bit line is don't care). The value of the register mask must be limited to the subsequent value, based on the desired chip-select region size. Any other value has an undefined result. When multiple chip-select regions with overlapping addresses are enabled concurrently, access to these chip-select regions is cancelled and a GPMC access error is posted. The mask field is programmed through the GPMC_CONFIG7_i[11-8] MASKADDRESS bit field.

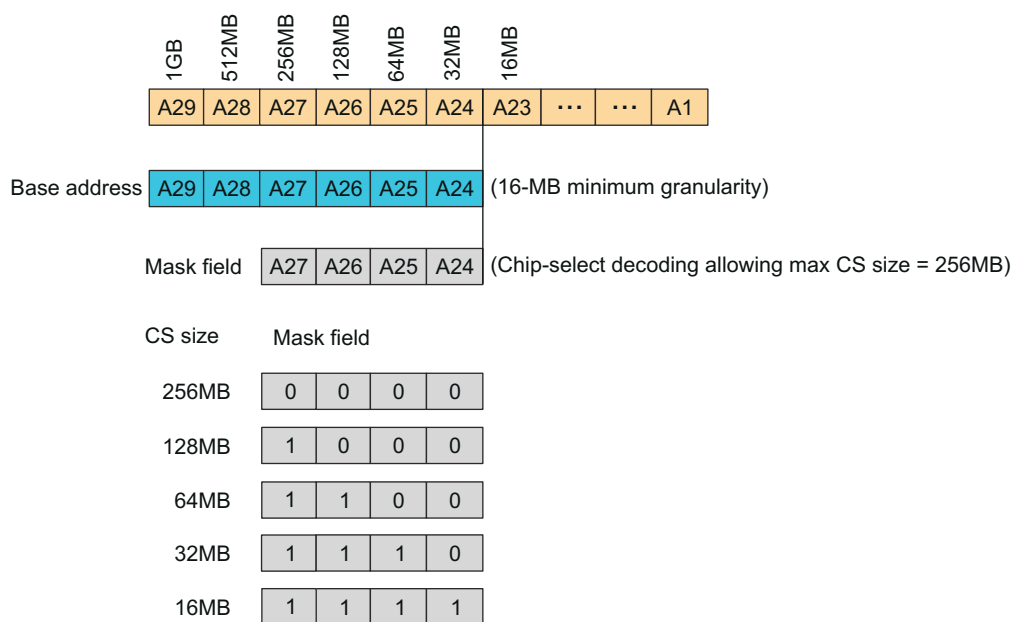

gpmc-006

Figure 13-132. Chip-Select Address Mapping and Decoding Mask

For example, to map the 128MB address space (from 2000 0000h to 27FF FFFFh), the GPMC_CONFIG7_i[5-0] BASEADDRESS bit field should be set to 20h.

Chip-select configuration (base and mask address or any protocol and timing settings) must be performed while the associated chip-select is disabled through the GPMC_CONFIG7_i[6] CSVALID bit (where i stands for the GPMC chip-select i, where i = 0 to 3). In addition, a chip-select configuration can be disabled only if there is no ongoing access to that chip-select. This requires monitoring the activity of the prefetch or write-posting engine if the engine is active on the chip-select. Also, the write buffer state must be monitored to wait for any posted write completion to the chip-select.

Any access attempted to a nonvalid GPMC address region (CSVALID disabled or address decoding outside a valid chip-select region) is not propagated to the external interface and a GPMC access error is posted. In case of overlapping chip-selects, an error is generated and no access occurs on either chip-select.

CS0 is the only chip-select region enabled after a power up or GPMC reset.

CAUTION

Although the GPMC interface can drive up to four chip-selects, the frequency specified for this interface is for a specific load. If this load is exceeded, the maximum frequency cannot be reached. One solution is to implement a board with buffers to allow the slowest device to maintain the total load on the lines at the value specified in the device-specific Datasheet.

13.3.1.4.7.2 Access Protocol

13.3.1.4.7.2.1 Supported Devices

The access protocol of each chip-select can be independently specified through the GPMC_CONFIG1_i[11-10] DEVICETYPE parameter (where i = 0 to 3) for:

- Random-access synchronous or asynchronous memory, such as NOR flash and SRAM
- NAND flash asynchronous devices

Note

For more information about the NAND flash GPMC basic programming model and NAND support, see [Section 13.3.1.4.11, GPMC NAND Device Basic Programming Model](#), and [Section 13.3.1.4.11.1, NAND Memory Device in Byte or Word16 Stream Mode](#).

13.3.1.4.7.2.2 Access Size Adaptation and Device Width

Each chip-select can be independently configured through the GPMC_CONFIG1_i[13-12] DEVICESIZE bit field (where i = 0 to 3) to interface with a 16- or 8-bit-wide device. System requests with data width greater than the external device data bus width are split into successive accesses according to the external device data-bus width and little-endian data organization.

13.3.1.4.7.2.3 Address/Data-Multiplexing Interface

For random synchronous or asynchronous memory interfacing (DEVICETYPE = 0b00), an address- and data-multiplexing protocol can be selected through the GPMC_CONFIG1_i[9-8] MUXADDDATA bit field (where i = 0 to 3). The nADV signal must be used as the external device address latch control signal. For the associated chip-select configuration, nADV assertion and deassertion time and nOE assertion time must be set to the appropriate value to meet the address latch setup/hold time requirements of the external device. See [Section 13.3.1.3, GPMC Integration](#).

Note

This address/data-multiplexing interface is not applicable to NAND device interfacing. NAND devices require a specific address, command, and data-multiplexing protocol. See [Section 13.3.1.4.11, NAND Device Basic Programming Model](#).

13.3.1.4.7.3 External Signals

13.3.1.4.7.3.1 WAIT Pin Monitoring Control

GPMC access time can be dynamically controlled using an external GPMC_WAIT pin when the external device access time is not deterministic and cannot be defined and controlled using only the GPMC internal RDACCESSTIME, WRACCESSTIME, and PAGEBURSTACCESSTIME wait-state generator.

The GPMC features two input WAIT pins: GPMC_WAIT1, and GPMC_WAIT0. These pins allow control of external devices with different WAIT pin polarity. They also allow the overlap of WAIT pin assertion from different devices without affecting access to devices for which the WAIT pin is not asserted.

- The GPMC_CONFIG1_i[17-16] WAITPINSELECT bit field (where i = 0 to 3) selects which input GPMC_WAIT pin is used for the device attached to the corresponding chip-select.

- The polarity of the WAIT pin is defined through the WAITxPINPOLARITY bit of the GPMC_CONFIG register. A WAIT pin configured to be active low means that low level on the WAIT signal indicates that the data is not ready and that the data bus is invalid. When a WAIT pin is inactive, data is valid.

The GPMC access engine can be configured per chip-select to monitor or not the WAIT pin of the external memory device, based on the access type: read or write.

- The GPMC_CONFIG1_i[22] WAITREADMONITORING bit defines whether or not the WAIT pin must be monitored during read accesses.
- The GPMC_CONFIG1_i[21] WAITWRITEMONITORING bit defines whether or not the WAIT pin must be monitored during write accesses.

The GPMC access engine can be configured to monitor the WAIT pin of the external memory device asynchronously or synchronously with the GPMC output clock, depending on the access type: synchronous or asynchronous (the GPMC_CONFIG1_i[29] READTYPE and GPMC_CONFIG1_i[27] WRITETYPE bits).

13.3.1.4.7.3.1.1 Wait Monitoring During Asynchronous Read Access

When WAIT pin monitoring is enabled for read accesses (WAITREADMONITORING), the effective access time is a logical AND combination of the RDACCESSTIME timing completion and the wait-deasserted state.

During asynchronous read accesses with WAIT pin monitoring enabled, the WAIT pin must be at a valid level (asserted or deasserted) for at least two GPMC clock cycles before RDACCESSTIME completes, to ensure correct dynamic access-time control through WAIT pin monitoring. The advance pipelining of the two GPMC clock cycles is the result of the internal synchronization requirements for the WAIT signal.

In this context, RDACCESSTIME is used as a wait invalid timing window and is set to such a value that the WAIT pin is at a valid state two GPMC clock cycles before RDACCESSTIME completes.

Similarly, during a multiple-access cycle (for example, asynchronous read page mode), the effective access time is a logical AND combination of PAGEBURSTACCESSTIME timing completion and the wait-deasserted state. Wait monitoring pipelining is also applicable to multiple accesses (access within a page).

- Wait monitored as active freezes the CYCLETIME counter. For an access within a page, when the CYCLETIME counter is by definition in a lock state, wait monitored as asserted extends the current access time in the page. Control signals are kept in their current state. The data bus is considered invalid, and no data are captured during this clock cycle.
- Wait monitored as inactive unfreezes the CYCLETIME counter. For an access within a page, when the CYCLETIME counter is by definition in a lock state, wait monitored as inactive completes the current access time and starts the next access phase in the page. The data bus is considered valid, and data are captured during this clock cycle. In case of a single access or if this was the last access in a multiple-access cycle, all signals are controlled according to their related control timing value and according to the CYCLETIME counter status.

When a delay larger than two GPMC clocks must be observed between wait-pin deactivation time and data valid time (including the required GPMC and the device data setup time), an extra delay can be added between wait-pin deassertion time detection and effective data-capture time and the effective unlock of the CYCLETIME counter. This extra delay can be programmed in the GPMC_CONFIG1_i[19-18] WAITMONITORINGTIME bit field (where i = 0 to 3).

Note

- The WAITMONITORINGTIME parameter does not delay the WAIT pin active or inactive detection, nor does it modify the two GPMC clocks pipelined detection delay.
- This extra delay is expressed as a number of GPMC output clock cycles, even though the access is defined as asynchronous, and no GPMC output clock is provided to the external device. Still, because GPMC_CONFIG1_i[1-0] GPMCFCLKDIVIDER is used as a divider for the GPMC clock, it must be programmed to define the correct WAITMONITORINGTIME delay.

Figure 13-133 shows wait behavior during an asynchronous single read access.

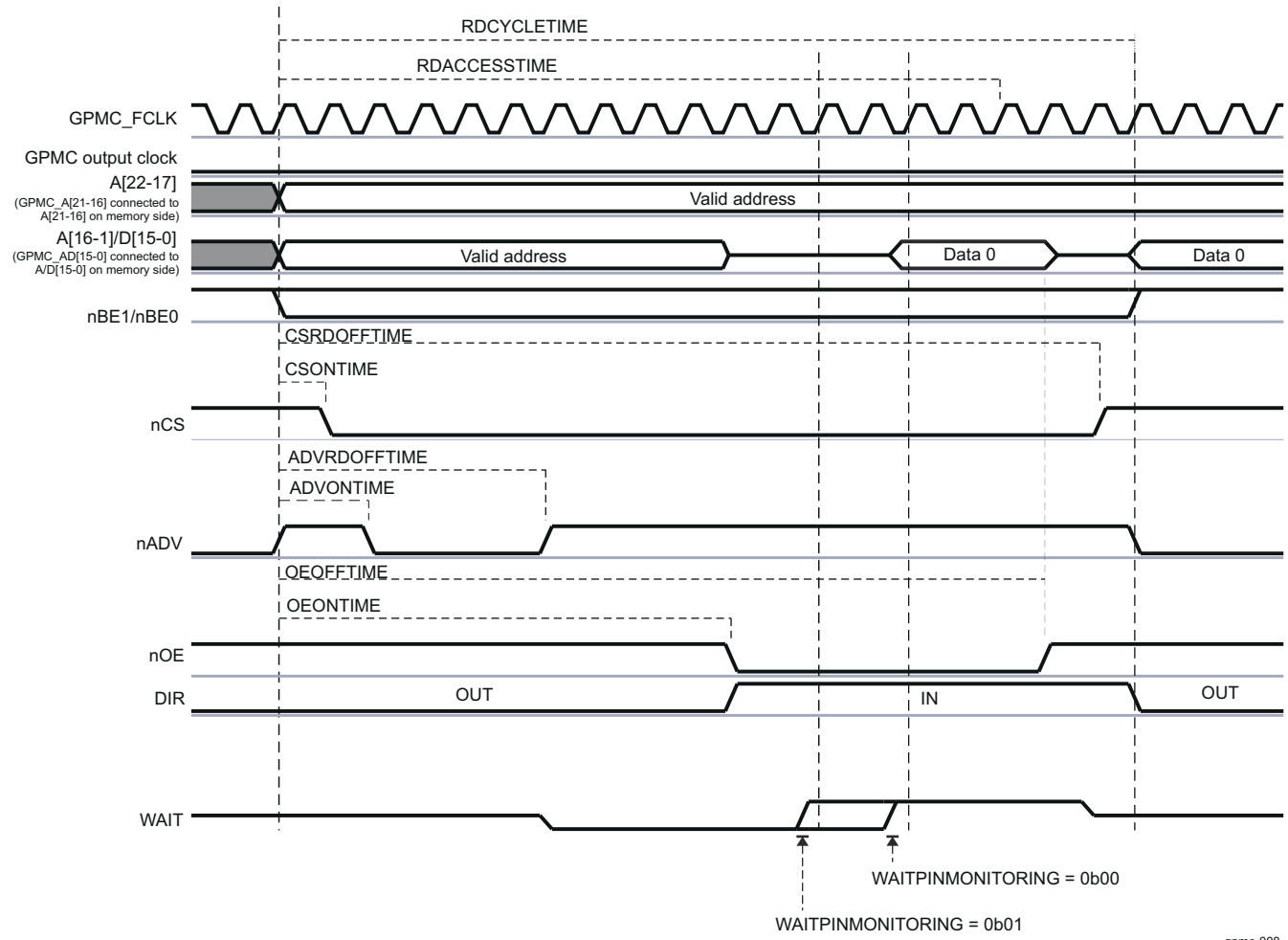

Figure 13-133. Wait Behavior During an Asynchronous Single Read Access (GPMCFCLKDivider = 1)

Note

The WAIT signal is active low. GPMC_CONFIG1_i[19-18] WAITMONITORINGTIME = 0b00, or 0b01.

13.3.1.4.7.3.1.2 Wait Monitoring During Asynchronous Write Access

When WAIT pin monitoring is enabled for write accesses (GPMC_CONFIG1_i[21] WAITWRITEMONITORING bit = 0x1), the wait invalid timing window is defined by the WRACCESSTIME field. WRACCESSTIME must be set so that the WAIT pin is at a valid state two GPMC clock cycles before WRACCESSTIME completes. The advance pipelining of the two GPMC clock cycles is the result of the internal synchronization requirements for the WAIT signal.

- Wait monitored as active freezes the CYCLETIME counter. This informs the GPMC that the data bus is not captured by the external device. The control signals are kept in their current state. The data bus still drives the data.
- Wait monitored as inactive unfreezes the CYCLETIME counter. This informs that the data bus is correctly captured by the external device. All signals, including the data bus, are controlled according to their related control timing value and to the CYCLETIME counter status.

When a delay larger than two GPMC clock cycles must be observed between wait-pin deassertion time and the effective data write into the external device (including the required GPMC data setup time and the device data setup time), an extra delay can be added between wait-pin deassertion time detection and effective data write

time into the external device and the effective unfreezing of the CYCLETIME counter. This extra delay can be programmed in the GPMC_CONFIG1_][19-18] WAITMONITORINGTIME bit field (where $i = 0$ to 3).

Note

- The WAITMONITORINGTIME parameter does not delay the WAIT pin assertion or deassertion detection, nor does it modify the two GPMC clock cycles pipelined detection delay.
- This extra delay is expressed as a number of GPMC output clock cycles, even though the access is defined as asynchronous, and even though no clock is provided to the external device. Still, because the GPMC_CONFIG1_][1-0] GPMCFCLKDIVIDER bit field is used as a divider for the GPMC clock, it must be programmed to define the correct WAITMONITORINGTIME delay.

13.3.1.4.7.3.1.3 Wait Monitoring During Synchronous Read Access

During synchronous accesses with WAIT pin monitoring enabled, the WAIT pin is captured synchronously with GPMC output clock, using the rising edge of this clock.

The WAIT signal can be programmed to apply to the same clock cycle in which it is captured. Alternatively, it can be sampled one or two GPMC output clock cycles ahead of the clock cycle to which it applies. This pipelining is applicable to the entire burst access and to all data phases in the burst access. This wait pipelining depth is programmed in the GPMC_CONFIG1_][19-18] WAITMONITORINGTIME bit field (where $i = 0$ to 3), and is expressed as a number of GPMC output clock cycles.

In synchronous mode, when WAIT pin monitoring is enabled (the GPMC_CONFIG1_][22] WAITREADMONITORING bit), the effective access time is a logical AND combination of the RDACCESSTIME timing completion and the wait-deasserted state detection.

Depending on the programmed value of WAITMONITORINGTIME, the WAIT pin must be at a valid level, either asserted or deasserted:

- In the same clock cycle the data is valid if WAITMONITORINGTIME = 0 (at RDACCESSTIME completion)
- In the WAITMONITORINGTIME \times (GPMCFCLKDIVIDER + 1) GPMC_FCLK clock cycles before RDACCESSTIME completion if WAITMONITORINGTIME is not equal to 0

Similarly, during a multiple-access cycle (burst mode), the effective access time is a logical AND combination of PAGEBURSTACCESSTIME timing completion and the WAIT-INACTIVE state. The wait pipelining-depth programming applies to the whole burst access.

- Wait monitored as active freezes the CYCLETIME counter. For an access within a burst (when the CYCLETIME counter is by definition in a lock state), wait monitored as active extends the current access time in the burst. Control signals are kept in their current state. The data bus is considered invalid, and no data are captured during this clock cycle.
- Wait monitored as inactive unfreezes the CYCLETIME counter. For an access within a burst (when the CYCLETIME counter is by definition in lock state), wait monitored as inactive completes the current access time and starts the next access phase in the burst. The data bus is considered valid, and data are captured during this clock cycle. In a single access or if this was the last access in a multiple-access cycle, all signals are controlled according to their relative control timing value and the CYCLETIME counter status.

Figure 13-134 shows wait behavior during a synchronous read burst access.

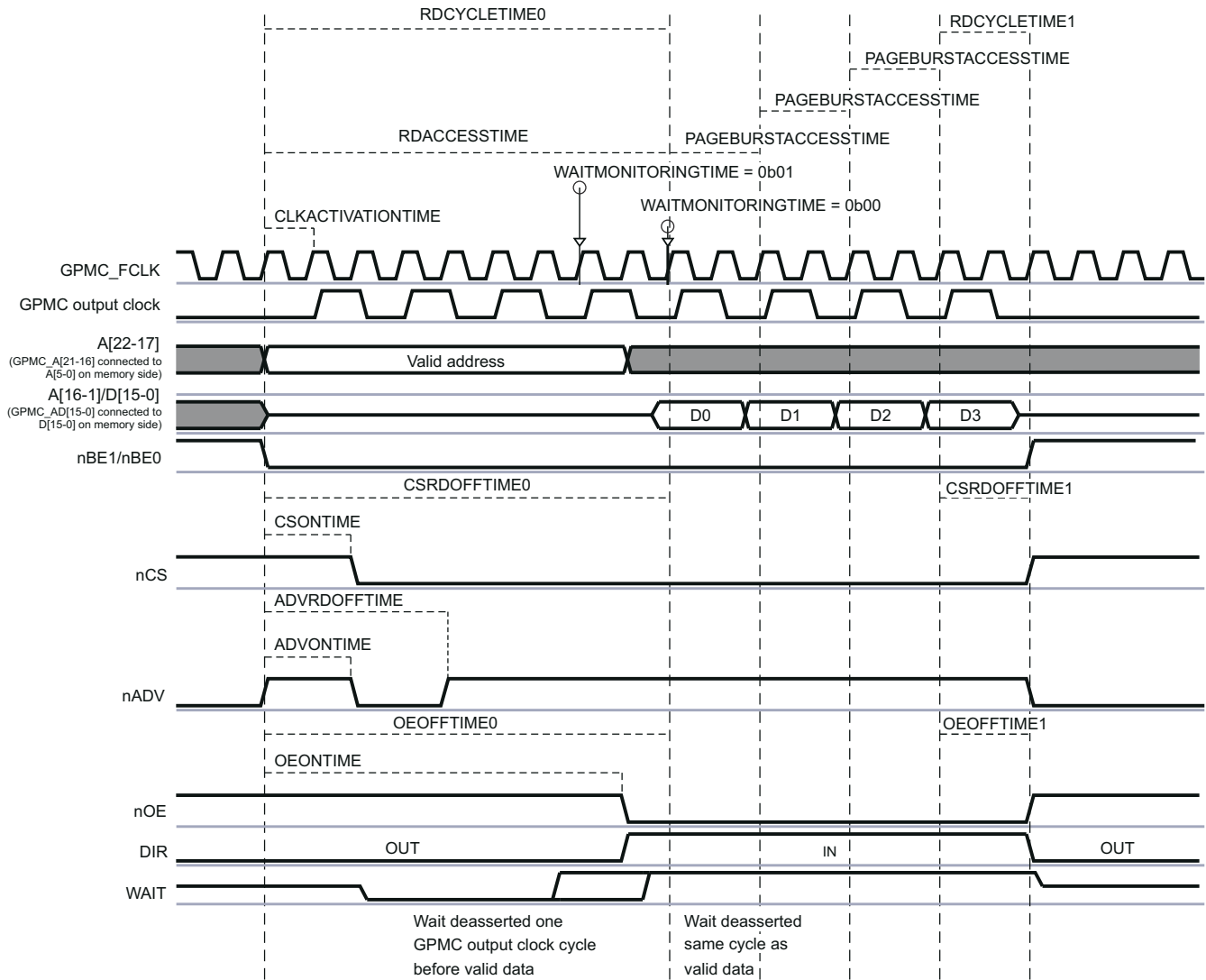

gpmc-009

Figure 13-134. Wait Behavior During a Synchronous Read Burst Access

Note

The WAIT signal is active low. WAITMONITORINGTIME = 0b00, 0b01.

13.3.1.4.7.3.1.4 Wait Monitoring During Synchronous Write Access

During synchronous accesses with WAIT pin monitoring enabled (the GPMC_CONFIG1_i[21] WAITWRITEMONITORING bit), the WAIT pin is captured synchronously with GPMC output clock, using the rising edge of this clock.

If enabled, external WAIT pin monitoring can be used in combination with WRACCESSTIME to delay the GPMC output clock capture edge of the effective memory device.

WAIT-monitoring pipelining depth is similar to synchronous read access:

- At WRACCESSTIME completion if WAITMONITORINGTIME = 0
- In the WAITMONITORINGTIME x (GPMCFCLKDIVIDER + 1) GPMC_FCLK cycles before WRACCESSTIME completion if WAITMONITORINGTIME is not equal to 0

Wait-monitoring pipelining definition applies to whole burst accesses:

- Wait monitored as active freezes the CYCLETIME counter. For accesses within a burst, when the CYCLETIME counter is by definition in a lock state, wait monitored as active indicates that the data bus is not being captured by the external device. Control signals are kept in their current state. The data bus is kept in its current state.
- Wait monitored as inactive unfreezes the CYCLETIME counter. For accesses within a burst, when the CYCLETIME counter is by definition in a lock state, wait monitored as inactive indicates the effective data capture of the bus by the external device and starts the next access of the burst. In case of a single access or if this was the last access in a multiple access cycle, all signals, including the data bus, are controlled according to their related control timing value and the CYCLETIME counter status.

Note

WAIT monitoring is supported for all configurations except GPMC_CONFIG1_i[19-18] WAITMONITORINGTIME = 0x0 (where i = 0 to 3) for write bursts with a clock divider of 1 or 2 (the GPMC_CONFIG1_i[1-0] GPMCFCLKDIVIDER bit field is equal to 0x0 or 0x1, respectively).

13.3.1.4.7.3.1.5 Wait With NAND Device

For information about the use of the WAIT pin for communication with a NAND flash external device, see [Section 13.3.1.4.11.2, NAND Device-Ready Pin](#).

13.3.1.4.7.3.1.6 Idle Cycle Control Between Successive Accesses

3.1.4.7.3.1.6.1 Bus Turnaround (BUSTURNAROUND)

To prevent data-bus contention, an access that follows a read access to a slow memory/device must be delayed (in other words, control the nCS/nOE deassertion to data bus in high-impedance delay).

The bus turnaround is a time-out counter starting after nCS or nOE deassertion time, whichever occurs first, and delays the next access start-cycle time. The counter is programmed through the GPMC_CONFIG6_i[3-0] BUSTURNAROUND bit field (where i = 0 to 3).

After a read access to a chip-select with a nonzero BUSTURNAROUND, the next access is delayed until the BUSTURNAROUND delay completes, if the next access is one of the following:

- A write access to any chip-select (the same or different chip-select from which the data was read)
- A read access to a different chip-select than the chip-select from which the data was read access
- A read or write access to a chip-select associated with an address/data-multiplexed device

Note

Bus keeping starts after bus turnaround completion so that DIR changes from IN to OUT after bus turnaround. The bus does not have enough time to go into high-impedance even though it can be driven with the same value before bus turnaround timing.

BUSTURNAROUND delay runs in parallel with GPMC_CONFIG6_i[3-0] CYCLE2CYCLEDELAY bit field delays. BUSTURNAROUND is a timing parameter for the ending chip-select access, while CYCLE2CYCLEDELAY is a timing parameter for the following chip-select access. The effective minimum delay between successive accesses is driven by these delay timing parameters and by the access type of the following access (see [Figure 13-135](#) through [Figure 13-137](#)).

Another way to prevent bus contention is to define an earlier nCS or nOE deassertion time for slow devices or to extend the value of RDCYCLETIME. Doing this prevents bus contention, but it also affects all accesses of this specific chip-select.

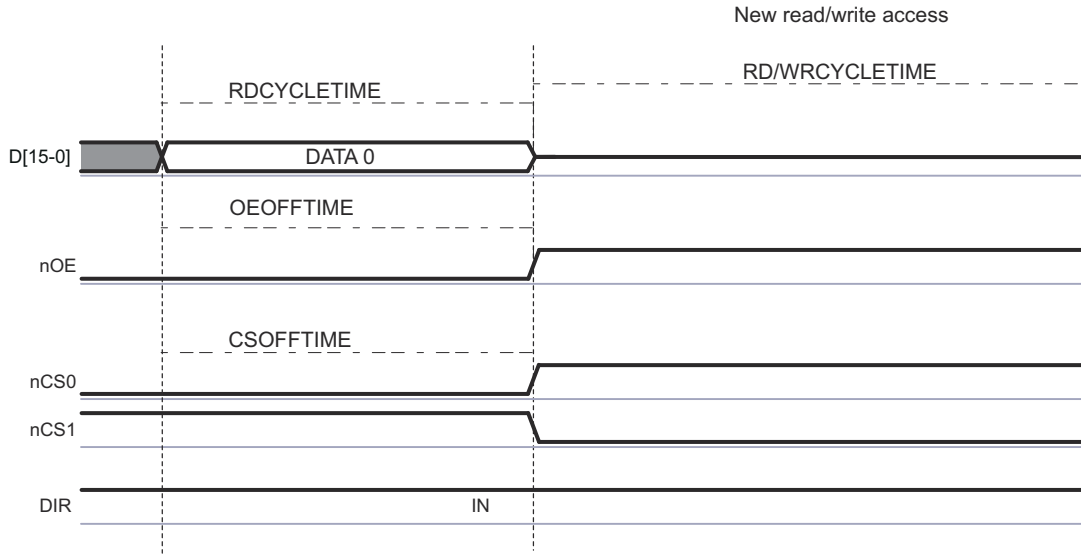

gpmc-049

Figure 13-135. Read-to-Read for an Address-Data Multiplexed Device, on Different Chip-Select, Without Bus Turnaround (nCS Attached to a Fast Device)

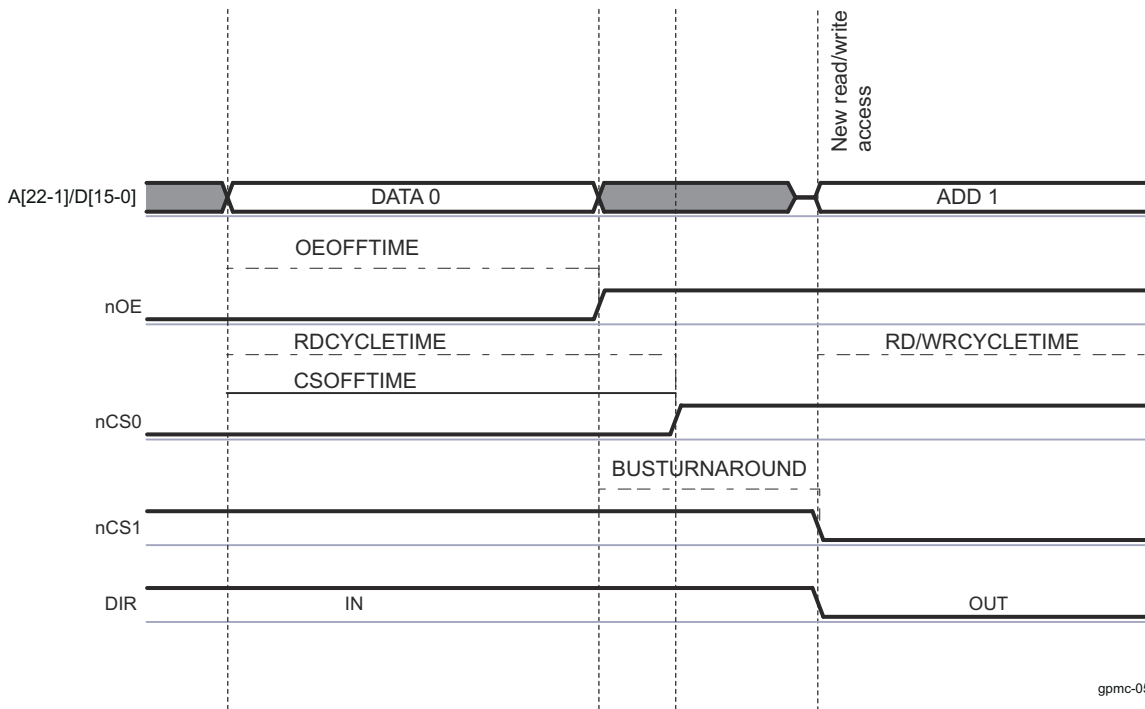

gpmc-050

Figure 13-136. Read- to-Read/Write for an Address-Data Multiplexed Device, on Different Chip-Select, With Bus Turnaround

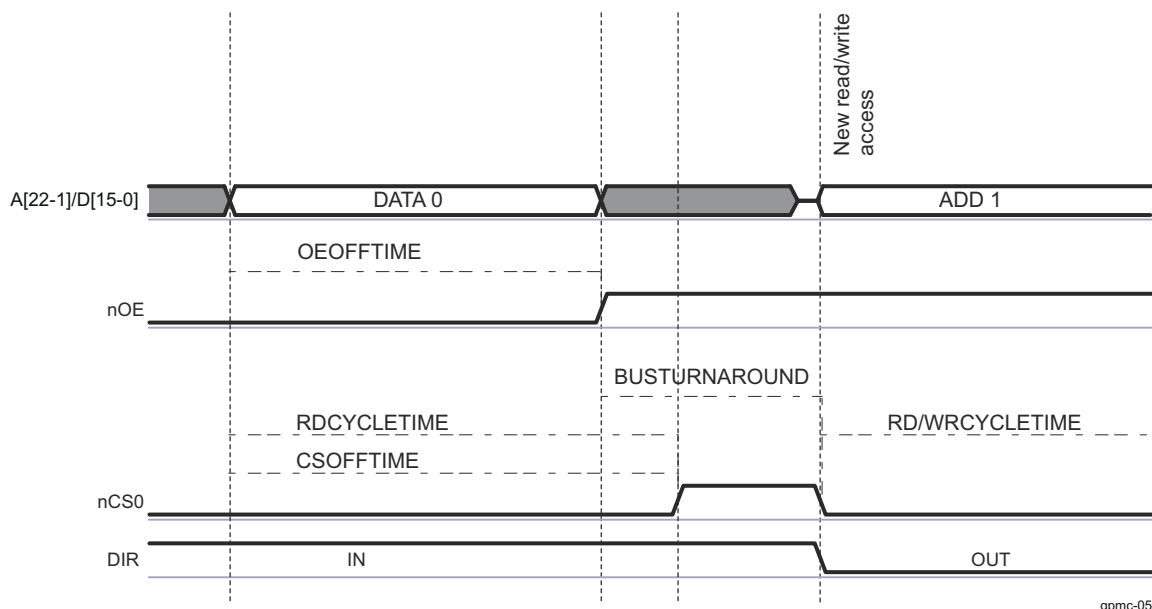

Figure 13-137. Read-to-Read/Write for a Address-Data or AAD-Multiplexed Device, on Same Chip-Select, With Bus Turnaround

3.1.4.7.3.1.6.2 Idle Cycles Between Accesses to Same Chip-Select (CYCLE2CYCLESAMECSSEN, CYCLE2CYCLEDELAY)

Some devices require a minimum chip-select signal inactive time between accesses. The GPMC_CONFIG6_i[7] CYCLE2CYCLESAMECSSEN bit (where i = 0 to 3) enables insertion of a minimum number of GPMC_FCLK cycles, defined by the GPMC_CONFIG6_i[11-8] CYCLE2CYCLEDELAY bit field, between successive accesses of any type (read or write) to the same chip-select.

If CYCLE2CYCLESAMECSSEN is enabled, any subsequent access to the same chip-select is delayed until its CYCLE2CYCLEDELAY completes. The CYCLE2CYCLEDELAY counter starts when CSRDOFFTIME/CSWROFFTIME completes.

The same applies to successive accesses occurring during 32-bit word or burst accesses split into successive single accesses when the single-access mode is used (GPMC_CONFIG1_i[30] READMULTIPLE = 0 or GPMC_CONFIG1_i[28] WRITEMULTIPLE = 0).

All control signals (CS, ADV#/ALE, BE0#/CLE, WE#, and GPMC output clock (CLK)) are kept inactive (ADV#/ALE, BE0#/CLE, and GPMC output clock at low level; and CS, OE#/RE, and WE at high level) during the idle GPMC_FCLK cycles. This prevents back-to-back accesses to the same chip-select without idle cycles between accesses.

3.1.4.7.3.1.6.3 Idle Cycles Between Accesses to Different Chip-Select (CYCLE2CYCLEDIFFCSSEN, CYCLE2CYCLEDELAY)

Because of the pipelined behavior of the system, successive accesses to different chip-selects can occur back-to-back with no idle cycles between accesses. Depending on the control signals (nCS, nADV/ALE, nBE0/CLE, nOE/RE, nWE) assertion and deassertion timing parameters and on the device timing parameters, the assertion times of some control signals may overlap between the successive accesses to a different chip-select. Similarly, some control signals (WE, OE/RE) may not respect required transition times.

To work around overlapping and to observe the required control-signal transitions, a minimum of CYCLE2CYCLEDELAY inactive cycles is inserted between the access being initiated to this chip-select and the previous access ending for a different chip-select. This applies to any type of access (read or write).

If the GPMC_CONFIG6_i[6] CYCLE2CYCLEDIFFCSSEN bit is enabled, the chip-select access is delayed until CYCLE2CYCLEDELAY cycles have expired since the end of a previous access to a different chip-select.

ADVANCE INFORMATION

CYCLE2CYCLEDELAY count starts at CSRDOFFTIME/CSWROFFTIME completion. All control signals are kept inactive during the idle GPMC_FCLK cycles.

Note

CYCLE2CYCLESAMECSEN and CYCLE2CYCLEDIFFCSEN must be set in the GPMC_CONFIG6_i registers to get idle cycles inserted between accesses on this chip-select and after accesses to a different chip-select, respectively.

The CYCLE2CYCLEDELAY delay runs in parallel with the BUSTURNAROUND delay. The BUSTURNAROUND is a timing parameter defined for the ending chip-select access, whereas CYCLE2CYCLEDELAY is a timing parameter defined for the starting chip-select access. The effective minimum delay between successive accesses is based on the larger delay timing parameter and on access type combination, because bus turnaround does not apply to all access types. For more information about bus turnaround, see [Section 3.1.4.7.3.1.6.1, Bus Turnaround \(BUSTURNAROUND\)](#).

Table 13-165 describes the configuration required for idle cycle insertion.

Table 13-165. Idle Cycle Insertion Configuration

1st Access Type	BUSTURN AROUND Timing Parameter	Second Access Type	Chip-Select	Add/Data Multiplexed	CYCLE2 CYCLE SAMECSEN Parameter	CYCLE2 CYCLE DIFFCSEN Parameter	Idle Cycle Insertion Between the Two Accesses
R/W	= 0	R/W	Any	Any	0	x	No idle cycles are inserted if the two accesses are well pipelined.
R	> 0	R	Same	Nonmuxed	x	0	No idle cycles are inserted if the two accesses are well pipelined.
R	> 0	R	Different	Nonmuxed	0	0	BUSTURNAROUND cycles are inserted.
R	> 0	R/W	Any	Muxed	0	0	BUSTURNAROUND cycles are inserted.
R	> 0	W	Any	Any	0	0	BUSTURNAROUND cycles are inserted.
W	> 0	R/W	Any	Any	0	0	No idle cycles are inserted if the two accesses are well pipelined.
R/W	= 0	R/W	Same	Any	1	x	CYCLE2CYCLEDELAY cycles are inserted.
R/W	= 0	R/W	Different	Any	x	1	CYCLE2CYCLEDELAY cycles are inserted.
R/W	> 0	R/W	Same	Any	1	x	CYCLE2CYCLEDELAY cycles are inserted. If BTA idle cycles already apply on these two back-to-back accesses, the effective delay is max (BUSTURNAROUND, CYCLE2CYCLEDELAY).
R/W	> 0	R/W	Different	Any	x	1	CYCLE2CYCLEDELAY cycles are inserted. If BTA idle cycles already apply on these two back-to-back accesses, the effective delay is maximum (BUSTURNAROUND, CYCLE2CYCLEDELAY).

13.3.1.4.7.3.1.7 Slow Device Support (TIMEPARAGRANULARITY Parameter)

All access-timing parameters can be multiplied by 2 by setting the GPMC_CONFIG1_i[4] TIMEPARAGRANULARITY bit (where i stands for the GPMC chip-select i, where i = 0 to 3). Increasing all access timing parameters allows support of slow devices.

13.3.1.4.7.3.2 DIR Pin

The DIR pin is used to control I/O direction on the GPMC data bus GPMC_D[15-0]. Depending on pad multiplexing, this signal can be output and used externally to the device, if required. The DIR pin is low during transmit (OUT) and high during receive (IN).

For write accesses, the DIR pin stays OUT from start-cycle time to end-cycle time.

For read accesses, the DIR pin goes from OUT to IN at nOE assertion time and stays IN until:

- BUSTURNAROUND is enabled
 - The DIR pin goes from IN to OUT at end-cycle time plus programmable bus turnaround time.
- BUSTURNAROUND is disabled
 - After an asynchronous read access, the DIR pin goes from IN to OUT at RDACCESSTIME + 1 GPMC_FCLK cycle or when RDCYCLETIME completes, whichever occurs last.
 - After a synchronous read access, the DIR pin goes from IN to OUT at RDACCESSTIME + 2 GPMC_FCLK cycles or when RDCYCLETIME completes, whichever occurs last.

Because of the bus-keeping feature of the GPMC, after a read or write access and with no other accesses pending, the default value of the DIR pin is OUT (see [Section 13.3.1.4.8.10, Bus Keeping Support](#)). In non-multiplexed devices, the DIR pin stays IN between two successive read accesses to prevent unnecessary toggling.

13.3.1.4.7.3.3 Reset

No reset signal is sent to the external memory device by the GPMC.

GPMC_RST is the reset signal for the GPMC module. It is connected and controlled by LPSC8 in VD_CORE. That reset signal initializes the internal state-machine and the internal configuration registers.

13.3.1.4.7.3.4 Write Protect Signal (nWP)

When connected to the attached memory device, the write protect signal can enable or disable the lockdown function of the attached memory. The nWP output pin value is controlled through the [4] WRITEPROTECT bit which is common for all chip selects.

13.3.1.4.7.3.5 Byte Enable (nBE1/nBE0)

Byte enable signals (nBE1/nBE0) are:

- Valid (asserted or nonasserted according to the incoming system request) from access start to access completion for asynchronous and synchronous single accesses
- Asserted low from access start to access completion for asynchronous and synchronous multiple read accesses
- Valid (asserted or nonasserted, according to the incoming system request) synchronously to each written data for synchronous multiple write accesses.

13.3.1.4.7.4 Error Handling

When an error occurs in the GPMC, the error information is stored in the GPMC_ERR_TYPE register and the address of the illegal access is stored in the GPMC_ERR_ADDRESS register. The GPMC keeps only the first error abort information until the GPMC_ERR_TYPE register is reset. Subsequent accesses that cause errors are not logged until the error is cleared by hardware with the GPMC_ERR_TYPE[0] ERRORVALID bit.

- ERRORNOTSUPPADD occurs when an incoming system request address decoding does not match any valid chip-select region, or if two chip-select regions are defined as overlapped, or if a register file access is tried outside the valid address range of 1KB.
- ERRORNOTSUPPMCMD occurs when an unsupported command request is decoded at the interconnect interface.
- ERRORTIMEOUT: A time-out mechanism prevents the system from hanging. The start value of the 9-bit time-out counter is defined in the GPMC_TIMEOUT_CONTROL register and enabled with the GPMC_TIMEOUT_CONTROL[0] TIMEOUTENABLE bit. When enabled, the counter starts at start-cycle time until it reaches 0 and data is not responded to from memory, and then a time-out error occurs. When data are

sent from memory, this counter is reset to its start value. With multiple accesses (asynchronous page mode or synchronous burst mode), the counter is reset to its start value for each data access within the burst.

The GPMC does not generate interrupts on these errors. An interrupt generation is handled at interconnect level.

13.3.1.4.8 GPMC Timing Setting

The GPMC offers maximum flexibility to support various access protocols. Most of the timing parameters of the protocol access used by the GPMC to communicate with attached memories or devices are programmable on a chip-select basis. Assertion and deassertion times of control signals are defined to match the attached memory or device timing specifications and to get maximum performance during accesses. For more information about GPMC_CLKOUT and GPMC_FCLK, see [Section 13.3.1.4.8.6, GPMC_CLKOUT](#).

Note

In the following sections, the start access time refers to the time at which the access begins.

13.3.1.4.8.1 Read Cycle Time and Write Cycle Time (RDCYCLETIME / WRCYCLETIME)

The GPMC_CONFIG5_i[4-0] RDCYCLETIME and GPMC_CONFIG5_i[12-8] WRCYCLETIME bit fields (where $i = 0$ to 3) define the address bus and byte-enable valid times for read and write accesses. To ensure a correct duty cycle of GPMC output clock between accesses, RDCYCLETIME and WRCYCLETIME are expressed in GPMC_FCLK cycles and must be multiples of the GPMC output clock cycle. The RDCYCLETIME and WRCYCLETIME bit fields can be set with a granularity of 1 or 2 through the GPMC_CONFIG5_i[4] TIMEPARAGRANULARITY bit.

When RDCYCLETIME or WRCYCLETIME completes, if they are not already deasserted, all control signals (nCS, nADV/ALE, nOE/RE, nWE, and BE0/CLE) are deasserted to their reset values, regardless of their deassertion time parameters.

An exception to this forced deassertion occurs when a pipelined request to the same chip-select or to a different chip-select is pending. In such a case, it is not necessary to deassert a control signal with deassertion time parameters equal to the cycle-time parameter. This exception to forced deassertion prevents any unnecessary glitches. This requirement also applies to BE signals, thus avoiding an unnecessary BE glitch transition when pipelining requests.

Note

All control signals (CS, ADV#/ALE, BE0#/CLE, WE#, and GPMC output clock) are kept inactive (ADV#/ALE, BE0#/CLE, and GPMC output clock at low level; and CS, OE#/RE, and WE at high level) during the idle GPMC_FCLK cycles.

If no inactive cycles are required between successive accesses to the same chip-select or a different chip-select (GPMC_CONFIG6_i[7] CYCLE2CYCLESAMECSEN = 0 or GPMC_CONFIG6_i[6] CYCLE2CYCLEDIFFCSEN = 0, where $i = 0$ to 3), and if assertion-time parameters associated with the pipelined access are equal to 0, asserted control signals (nCS, nADV/ALE, nBE0/CLE, nWE, and nOE/RE) are kept asserted. This applies to any read/write to read/write access combination.

If inactive cycles are inserted between successive accesses (that is, CYCLE2CYCLESAMECSEN = 1 or CYCLE2CYCLEDIFFCSEN = 1), the control signals are forced to their respective default reset values for the number of GPMC_FCLK cycles defined in CYCLE2CYCLEDELAY.

13.3.1.4.8.2 nCS: Chip-Select Signal Control Assertion/Deassertion Time (CSONTIME / CSRDOFFTIME / CSWROFFTIME / CSEXTRADELAY)

The GPMC_CONFIG2_i[3-0] CSONTIME bit field (where $i = 0$ to 3) defines the nCS signal-assertion time relative to the start access time. It is common for read and write accesses.

The GPMC_CONFIG2_i[12-8] CSRDOFFTIME (read access) and GPMC_CONFIG2_i[20-16] CSWROFFTIME (write access) bit fields define the nCS signal deassertion time relative to start access time.

The CSONTIME, CSRDOFFTIME, and CSWROFFTIME parameters apply to synchronous and asynchronous modes. CSONTIME can be used to control an address and byte-enable setup time before chip-select assertion. CSRDOFFTIME and CSWROFFTIME can be used to control an address and byte-enable hold time after chip-select deassertion.

nCS signal transitions, as controlled through CSONTIME, CSRDOFFTIME, and CSWROFFTIME, can be delayed by a half-GPMC_FCLK period by enabling the GPMC_CONFIG2_i[7] CSEXTRADelay bit. This half-GPMC_FCLK period provides more granularity on the nCS assertion and deassertion time to ensure proper setup and hold time relative to GPMC output clock. CSEXTRADelay is especially useful in configurations where GPMC output clock and GPMC_FCLK have the same frequency, but it can also be used for all GPMC configurations. If enabled, CSEXTRADelay applies to all parameters that control nCS transitions.

The CSEXTRADelay bit must be used carefully to avoid control signal overlap between successive accesses to different chip-selects. This implies the need to program the RDCYCLETIME and WRCYCLETIME bit fields to be greater than the nCS signal-deassertion time, including the extra half-GPMC_FCLK-period delay.

13.3.1.4.8.3 nADV/ALE: Address Valid/Address Latch Enable Signal Control Assertion/Deassertion Time (ADVONTIME / ADVRDOFFTIME / ADVWROFFTIME / ADVEXTRADelay/ADVAADMUXONTIME/ADVAADMUXRDOFFTIME/ADVAADMUXWROFFTIME)

The GPMC_CONFIG3_i[3-0] ADVONTIME field (where i = 0 to 3) defines the nADV/ALE signal-assertion time relative to start access time. It is common to read and write accesses.

The GPMC_CONFIG3_i[12-8] ADVRDOFFTIME (read access) and GPMC_CONFIG3_i[20-16] ADVWROFFTIME (write access) bit fields define the nADV/ALE signal-deassertion time relative to start access time.

ADVONTIME can be used to control an address and byte-enable valid setup time control before nADV/ALE assertion. ADVRDOFFTIME and ADVWROFFTIME can be used to control an address and byte-enable valid hold time control after nADV/ALE deassertion. ADVRDOFFTIME and ADVWROFFTIME apply to synchronous and asynchronous modes.

The nADV/ALE signal transitions as controlled through ADVONTIME, ADVRDOFFTIME, and ADVWROFFTIME can be delayed by a half-GPMC_FCLK period by enabling the GPMC_CONFIG3_i[7] ADVEXTRADelay bit. This half-GPMC_FCLK period provides more granularity on nADV/ALE assertion and deassertion time to ensure proper setup and hold time relative to GPMC output clock. The ADVEXTRADelay configuration parameter is especially useful in configurations where GPMC output clock and GPMC_FCLK have the same frequency, but can be used for all GPMC configurations. If enabled, ADVEXTRADelay applies to all parameters controlling nADV/ALE transitions.

ADVEXTRADelay must be used carefully to avoid control-signal overlap between successive accesses to different chip-selects. This implies the need to program the RDCYCLETIME and WRCYCLETIME bit fields to be greater than nADV/ALE signal-deassertion time, including the extra half-GPMC_FCLK-period delay.

GPMC_CONFIG3_i[6-4] ADVAADMUXONTIME, GPMC_CONFIG3_i[26-24] ADVAADMUXRDOFFTIME, and GPMC_CONFIG3_i[30-28] ADVAADMUXWROFFTIME parameters have the same functions as ADVONTIME, ADVRDOFFTIME, and ADVWROFFTIME, but apply to the first address phase in the AAD-multiplexed protocol. The user must ensure that ADVAADMUXxxOFFTIME is programmed to a value less than or equal to ADVxxOFFTIME. Functionality in AAD-multiplexed mode is undefined if the settings do not comply with this requirement. ADVAADMUXxxOFFTIME can be programmed to the same value as ADVONTIME if no high nADV pulse is needed between the two AAD-multiplexed address phases, which is the typical case in synchronous mode. In this configuration, nADV is kept low until it reaches the correct ADVxxOFFTIME.

For more information about the use of ADVONTIME, ADVRDOFFTIME, ADVWROFFTIME, and ADVAADMUXRDOFFTIME and ADVAADMUXWROFFTIME for command latch enable (CLE) and address latch enable (ALE) use for a NAND flash interface, see [Section 13.3.1.4.11, GPMC NAND Access Description](#).

13.3.1.4.8.4 nOE/nRE: Output Enable/Read Enable Signal Control Assertion/Deassertion Time (OEONTIME / OEOFFTIME / OEXTRADELAY / OEAADMUXONTIME / OEAADMUXOFFTIME)

The GPMC_CONFIG4_i[3-0] OEONTIME bit field (where i = 0 to 3) defines the nOE/nRE signal assertion time relative to start access time. It applies only to read accesses.

The GPMC_CONFIG4_i[12-8] OEOFFTIME bit field defines the nOE/nRE signal deassertion time relative to start access time. It applies only to read accesses. nOE/nRE is not asserted during a write cycle.

The OEONTIME, OEOFFTIME, OEAADMUXONTIME, and OEAADMUXOFFTIME parameters apply to synchronous and asynchronous modes. OEONTIME can be used to control an address and byte enable valid setup time control before nOE/nRE assertion. OEOFFTIME can be used to control an address and byte-enable valid hold time control after nOE/nRE assertion.

The OEAADMUXONTIME and OEAADMUXOFFTIME parameters have the same functions as OEONTIME and OEOFFTIME, but apply to the first OE assertion in the AAD-multiplexed protocol for a read phase, or to the only OE assertion for a write phase. The user must ensure that OEAADMUXOFFTIME is programmed to a value less than OEONTIME. Functionality in AAD-multiplexed mode is undefined if the settings do not comply with this requirement. OEAADMUXOFFTIME must never be equal to OEONTIME because the AAD-multiplexed protocol requires a second address phase with the nOE signal deasserted before nOE can be asserted again to define a read command.

The nOE/RE signal transitions as controlled through OEONTIME, OEOFFTIME, OEAADMUXONTIME, and OEAADMUXOFFTIME can be delayed by a half-GPMC_FCLK period by enabling the GPMC_CONFIG4_i[7] OEXTRADELAY bit. This half-GPMC_FCLK period provides more granularity on the nOE/RE assertion and deassertion time to ensure proper setup and hold time relative to GPMC output clock. If enabled, OEXTRADELAY applies to all parameters controlling nOE/nRE transitions.

OEXTRADELAY must be used carefully, to avoid control-signal overlap between successive accesses to different chip-selects. This implies the need to program RDCYCLETIME and WRCYCLETIME to be greater than the nOE/RE signal-deassertion time, including the extra half-GPMC_FCLK-period delay.

Note

When the GPMC generates a read access to an address-/data-multiplexed device, it drives the address bus until nOE assertion time.

13.3.1.4.8.5 nWE: Write Enable Signal Control Assertion/Deassertion Time (WEONTIME / WEOFFTIME / WEEXTRADELAY)

The GPMC_CONFIG4_i[19-16] WEONTIME bit field (where i = 0 to 3) defines the nWE signal-assertion time relative to start access time. The GPMC_CONFIG4_i[28-24] WEOFFTIME bit field defines the nWE signal-deassertion time relative to start access time. These bit fields apply only to write accesses. nWE is not asserted during a read cycle.

WEONTIME can be used to control an address and byte-enable valid setup time control before nWE assertion. WEOFFTIME can be used to control an address and byte-enable valid hold time control after nWE assertion.

nWE signal transitions as controlled through WEONTIME, and WEOFFTIME can be delayed by a half-GPMC_FCLK period by enabling the GPMC_CONFIG4_i[23] WEEXTRADELAY bit. This half-GPMC_FCLK period provides more granularity on nWE assertion and deassertion time to ensure proper setup and hold time relative to GPMC output clock. If enabled, WEEXTRADELAY applies to all parameters controlling nWE transitions.

The WEEXTRADELAY bit must be used carefully to avoid control-signal overlap between successive accesses to different chip-selects. This implies the need to program the WRCYCLETIME bit field to be greater than the nWE signal-deassertion time, including the extra half-GPMC_FCLK-period delay.

13.3.1.4.8.6 GPMC_CLKOUT

The GPMC output clock generated for external synchronous memory or device is GPMC_CLKOUT.

- The GPMC_CLKOUT clock frequency is the GPMC_FCLK functional clock frequency divided by 1, 2, 3, or 4, depending on the GPMC_CONFIG1_i[1-0] GPMCFCLKDIVIDER bit field (where i = 0 to 3), with a guaranteed 50-percent duty cycle. For information about the duty cycle error, see the device-specific Datasheet.
- The GPMC_CLKOUT clock is activated only when the access in progress is defined as synchronous (read or write access).
- The GPMC_CONFIG1_i[26-25] CLKACTIVATIONTIME bit field (where i = 0 to 3) defines the number of GPMC_FCLK cycles from start access time to GPMC_CLKOUT activation.
- The GPMC_CLKOUT clock is stopped when cycle time completes and is asserted low between accesses.
- The GPMC_CLKOUT clock is kept low when access is defined as asynchronous.

CAUTION

When the cycle time completes, the GPMC_CLKOUT may be high because of the GPMC_CONFIG1_i[1-0] GPMCFCLKDIVIDER bit field. To ensure correct stoppage of the GPMC_CLKOUT clock within the required 50-percent duty cycle, the user must extend the RDCYCLETIME or WRCYCLETIME value.

Note

To ensure a correct external clock cycle, the following rules must be applied:

- (RDCYCLETIME CLKACTIVATIONTIME) must be a multiple of (GPMCFCLKDIVIDER + 1).
- The PAGEBURSTACCESSTIME value must be a multiple of (GPMCFCLKDIVIDER + 1).

13.3.1.4.8.7 GPMC Output Clock and Control Signals Setup and Hold

Control-signal transition (assertion and deassertion) setup and hold values with respect to the GPMC output clock edge can be controlled in the following ways:

- For the GPMC output clock signal, the GPMC_CONFIG1_i[26-25] CLKACTIVATIONTIME bit field (where i = 0 to 3) allows setup and hold control of control-signal assertion time.
- The use of a divided GPMC output clock allows setup and hold control of the control-signal assertion and deassertion times.
- When the GPMC output clock runs at the GPMC_FCLK frequency so that GPMC output clock edge and control-signal transitions refer to the same GPMC_FCLK edge, the control-signal transitions can be delayed by a half-GPMC_FCLK period to provide minimum setup and hold times. This half-GPMC_FCLK delay is enabled with the CSEXTRADelay, ADVEXTRADelay, OEXTRADelay, or WEXTRADelay parameter. This delay must be used carefully to prevent control-signal overlap between successive accesses to different chip-selects. This implies that the RDCYCLETIME and WRCYCLETIME are greater than the last control-signal deassertion time, including the extra half-GPMC_FCLK cycle.

13.3.1.4.8.8 Access Time (RDACCESSTIME / WRACCESSTIME)

The read/write access time durations can be programmed independently through the GPMC_CONFIG5_i[20-16] RDACCESSTIME and GPMC_CONFIG6_i[28-24] WRACCESSTIME bit fields (where i = 0 to 3). This allows nOE and GPMC data-capture timing parameters to be independent of nWE and memory device data capture timing parameters. The RDACCESSTIME and WRACCESSTIME bit fields can be set with a granularity of 1 or 2 through the GPMC_CONFIG1_i[4] TIMEPARAGRANULARITY bit.

13.3.1.4.8.8.1 Access Time on Read Access

In asynchronous read mode, for single and paged accesses, the GPMC_CONFIG5_i[20-16] RDACCESSTIME bit field (where i = 0 to 3) defines the number of GPMC_FCLK cycles from start access time to the GPMC_FCLK rising edge used for the first data capture. RDACCESSTIME must be programmed to the rounded greater value (in GPMC_FCLK cycles) of the read access time of the attached memory device.

In synchronous read mode, for single or burst accesses, RDACCESSTIME defines the number of GPMC_FCLK cycles from the start access time to the GPMC_FCLK rising edge corresponding to the GPMC output clock rising edge used for the first data capture.

GPMC output clock, which is sent to the memory device for synchronization with the GPMC controller, is internally retimed to correctly latch the returned data. The GPMC_CONFIG5_i[4-0] RDCYCLETIME bit field must be greater than RDACCESSTIME to let the GPMC latch the last return data using the internally retimed GPMC output clock.

The external WAIT signal can be used in conjunction with RDACCESSTIME to control the effective GPMC data-capture GPMC_FCLK edge on read access in asynchronous and synchronous modes. For more information about wait monitoring, see [Section 13.3.1.4.7.3.1](#), *WAIT Pin Monitoring Control*.

13.3.1.4.8.8.2 Access Time on Write Access

In asynchronous write mode, the GPMC_CONFIG6_i[28-24] WRACCESSTIME timing parameter is not used to define the effective write access time. Instead, it is used as a wait invalid timing window and must be set to a correct value so that the GPMC_WAIT pin is at a valid state two GPMC output clock cycles before WRACCESSTIME completes. For more information about wait monitoring, see [Section 13.3.1.4.7.3.1](#), *WAIT Pin Monitoring Control*.

In synchronous write mode, for single or burst accesses, WRACCESSTIME defines the number of GPMC_FCLK cycles from the start access time to the GPMC output clock rising edge used by the memory device for the first data capture.

The external WAIT signal can be used in conjunction with WRACCESSTIME to control the effective memory device data-capture GPMC output clock edge for a synchronous write access. For more information about wait monitoring, see [Section 13.3.1.4.7.3.1](#), *WAIT Pin Monitoring Control*.

13.3.1.4.8.9 Page Burst Access Time (PAGEBURSTACCESSTIME)

The GPMC_CONFIG5_i[27-24] PAGEBURSTACCESSTIME bit field (where $i = 0$ to 3) can be set with a granularity of 1 or 2 through the GPMC_CONFIG1_i[4] TIMEPARAGRANULARITY bit.

13.3.1.4.8.9.1 Page Burst Access Time on Read Access

In asynchronous page read mode, the delay between successive word captures in a page is controlled through the PAGEBURSTACCESSTIME bit field. The PAGEBURSTACCESSTIME parameter must be programmed to the rounded greater value (in GPMC_FCLK cycles) of the read access time of the attached device.

In synchronous burst read mode, the delay between successive word captures in a burst is controlled through the PAGEBURSTACCESSTIME bit field.

The external WAIT signal can be used in conjunction with PAGEBURSTACCESSTIME to control the effective GPMC data-capture GPMC_FCLK edge on read access. For more information about wait monitoring, see [Section 13.3.1.4.7.3.1](#), *WAIT Pin Monitoring Control*.

13.3.1.4.8.9.2 Page Burst Access Time on Write Access

Asynchronous page write mode is not supported. PAGEBURSTACCESSTIME is irrelevant in this case.

In synchronous burst write mode, PAGEBURSTACCESSTIME controls the delay between successive memory device word captures in a burst.

The external WAIT signal can be used in conjunction with PAGEBURSTACCESSTIME to control the effective memory device data capture GPMC output clock edge in synchronous write mode. For more information about wait monitoring, see [Section 13.3.1.4.7.3.1](#), *WAIT Pin Monitoring Control*.

13.3.1.4.8.10 Bus Keeping Support

At the end cycle time of a read access, if no other access is pending, the GPMC drives the bus with the last data read after RDCYCLETIME completes to prevent bus floating and reduce power consumption.

After a write access, if no other access is pending, the GPMC keeps driving the data bus after WRCYCLETIME completes with the same data to prevent bus floating and power consumption.

13.3.1.4.9 GPMC NOR Access Description

For each chip-select configuration, the read access can be specified as asynchronous or synchronous access through the GPMC_CONFIG1_i[29] READTYPE bit (where i = 0 to 3). For each chip-select configuration, the write access can be specified as synchronous or asynchronous access through the GPMC_CONFIG1_i[27] WRITETYPE bit where (i = 0 to 3).

Asynchronous and synchronous read and write access time and related control signals are controlled through timing parameters that refer to GPMC_FCLK. The primary difference of synchronous mode is the availability of a configurable clock interface to control the external device. Synchronous mode also affects data-capture and wait-pin monitoring schemes in read access.

For more information about asynchronous and synchronous access, see the descriptions of GPMC output clock (CLK), RdAccessTime, WrAccessTime, and WAIT pin monitoring.

For more information about timing-parameter settings, see the sample timing diagrams in this chapter.

Note

The address bus and nBE[1-0] are fixed for the duration of a synchronous burst read access, but they are updated for each beat of an asynchronous page-read access.

13.3.1.4.9.1 Asynchronous Access Description

This section describes:

- Asynchronous single-read operation on an address/data multiplexed device
- Asynchronous single write operation on an address/data-multiplexed device
- Asynchronous single read operation on an AAD-multiplexed device
- Asynchronous single write operation on an AAD-multiplexed device
- Asynchronous multiple (page) read operation on a non-multiplexed device

In asynchronous operations GPMC output clock is not provided outside the GPMC and is kept low.

13.3.1.4.9.1.1 Access on Address/Data Multiplexed Devices

13.3.1.4.9.1.1.1 Asynchronous Single-Read Operation on an Address/Data Multiplexed Device

Figure 13-138 shows an asynchronous single read operation on an address/data-multiplexed device.

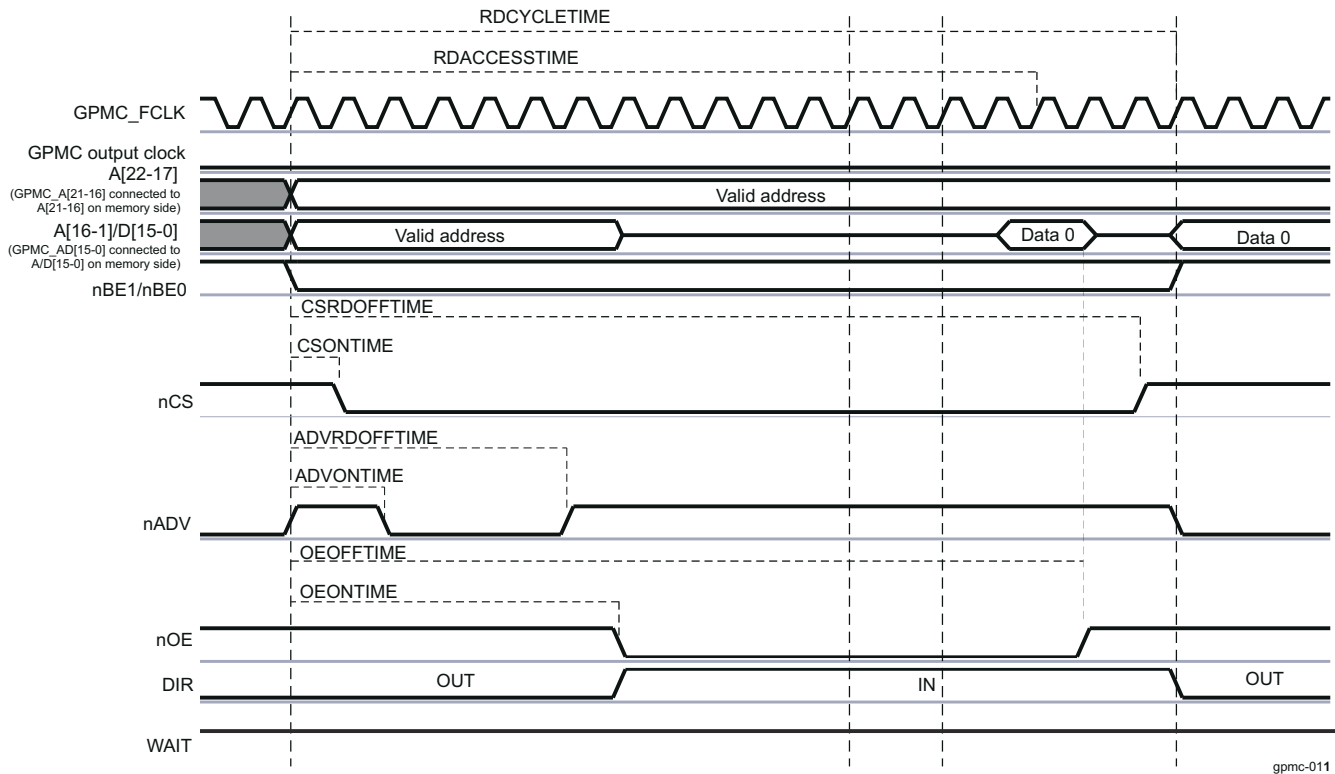

Figure 13-138. Asynchronous Single Read on an Address/Data-Multiplexed Device

For formulas to calculate timing parameters, see [Section 13.3.1.5.6.1, GPMC Timing Parameters Formulas](#).

[Table 13-206](#) lists the timing bit fields to set up to configure the GPMC in asynchronous single-read mode.

When the GPMC generates a read access to an address/data-multiplexed device, it drives the address bus until nOE assertion time. For more information, see [Section 13.3.1.4.7.2.3, Address/Data-Multiplexing Interface](#).

Address bits (A[16-1] from a GPMC perspective, A[15-0] from an external device perspective) are placed on the address/data bus, and the remaining address bits GPMC_A[22-16] are placed on the address bus. The address phase ends at nOE assertion, when the DIR signal goes from OUT to IN.

- Chip-select signal nCS:
 - nCS assertion time is controlled by the GPMC_CONFIG2_i[3-0] CS ONTIME bit field. It controls the address setup time to nCS assertion.
 - nCS deassertion time is controlled by the GPMC_CONFIG2_i[12-8] CSRD OFFTIME bit field. It controls the address hold time from nCS deassertion.
- Address valid signal nADV:
 - nADV assertion time is controlled by the GPMC_CONFIG3_i[3-0] ADV ONTIME bit field.
 - nADV deassertion time is controlled by the GPMC_CONFIG3_i[12-8] ADVRDOFFTIME bit field.
- Output enable signal nOE:
 - nOE assertion indicates a read cycle.
 - nOE assertion time is controlled by the GPMC_CONFIG4_i[3-0] OE ONTIME bit field.
 - nOE deassertion time is controlled by the GPMC_CONFIG4_i[12-8] OE OFFTIME bit field.
- Read data is latched when RDACCESSTIME completes. Access time is defined in the GPMC_CONFIG5_i[20-16] RDACCESSTIME bit field.
- Direction signal DIR: DIR goes from OUT to IN at the same time that nOE is asserted.
- The end of the access is defined by the GPMC_CONFIG5_i[4-0] RDCYCLETIME parameter.

In the GPMC, when a 16-bit wide device is attached to the controller, a 32-bit word write access is split into two 16-bit word write accesses. For more information about GPMC access size and type adaptation, see [Section 13.3.1.4.9.5, System Burst Versus External Device Burst Support](#).

Between two successive accesses, if an nCS pulse is needed:

- The GPMC_CONFIG6_i[11-8] CYCLE2CYCLEDELAY bit field can be programmed with the GPMC_CONFIG6_i[7] CYCLE2CYCLESAMECSSEN bit enabled.
- The CSWROFFTIME and CSONTIME parameters also allow a chip-select pulse, but this affects all other types of access.

ADVANCE INFORMATION

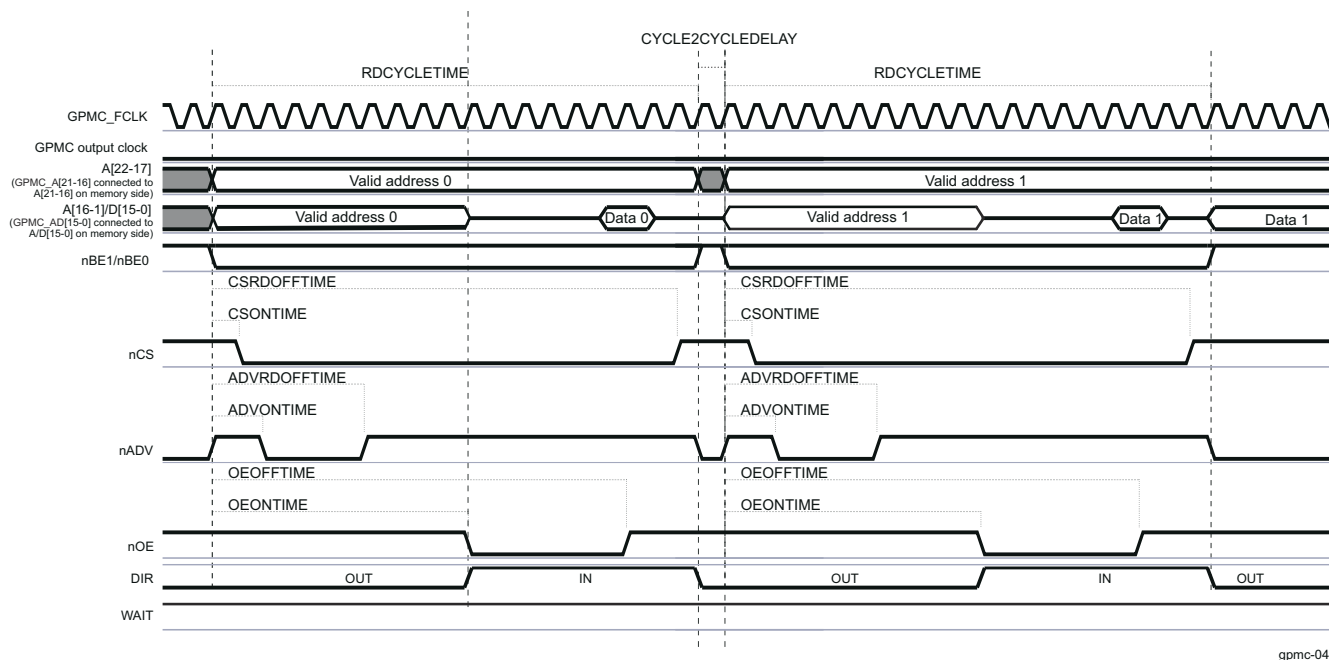

gpmc-044

Figure 13-139. Two Asynchronous Single-Read Accesses on an Address/Data-Multiplexed Device (32-Bit Read Split Into 2 x 16-Bit Read)

13.3.1.4.9.1.1.2 Asynchronous Single-Write Operation on an Address/Data-Multiplexed Device

Figure 13-140 shows an asynchronous single-write operation on an address/data-multiplexed device.

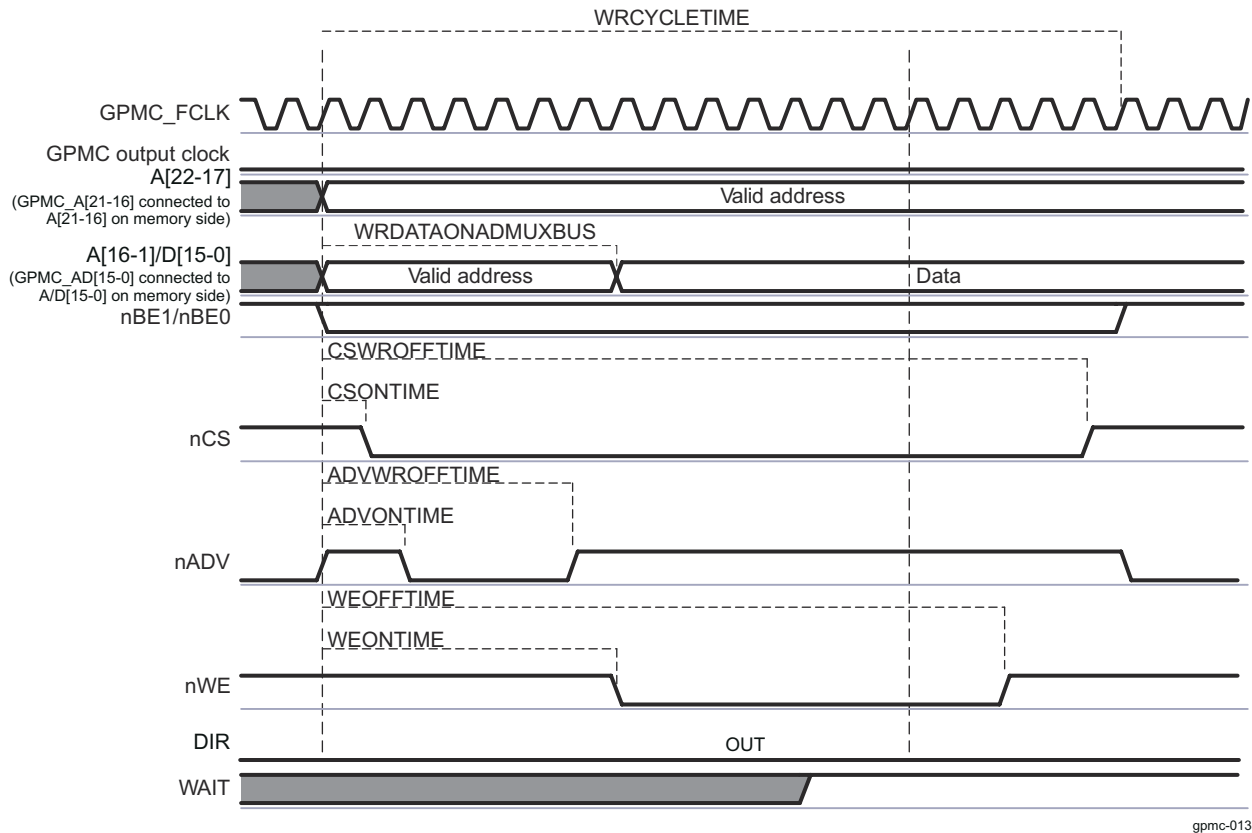

Figure 13-140. Asynchronous Single-Write on an Address/Data-Multiplexed Device

For formulas to calculate timing parameters, see [Section 13.3.1.5.6.1, GPMC Timing Parameters Formulas](#).

[Table 13-206](#) lists the timing bit fields to set up to configure the GPMC in asynchronous single-write mode.

When the GPMC generates a write access to an address/data-multiplexed device, it drives the address bus until nWE assertion time. For more information, see [Section 13.3.1.4.7.2.3, Address/Data-Multiplexing Interface](#).

The nCS and nADV signals are controlled in the same way as for a asynchronous single-read operation on an address/data-multiplexed device.

- Write enable signal nWE:
 - nWE assertion indicates a write cycle.
 - nWE assertion time is controlled by the GPMC_CONFIG4_i[19-16] WEONTIME bit field.
 - nWE deassertion time is controlled by the GPMC_CONFIG4_i[28-24] WEOFFTIME bit field.
- Direction signal DIR: DIR signal is OUT during the entire access.
- The end of the access is defined by the GPMC_CONFIG5_i[12-8] WRCYCLETIME parameter.

Address bits A[16-1] (GPMC point of view) are placed on the address/data bus at the start of cycle time, and the remaining address bits A[22-17] are placed on the address bus.

Data is driven on the address/data bus at a GPMC_CONFIG6_i[19-16] WRDATAONADMUXBUS time.

Note

Multiple write access in asynchronous mode is not supported. If WRITEMULTIPLE is enabled with WRITETYPE as asynchronous, the GPMC processes single asynchronous accesses.

After a write operation, if no other access (read or write) is pending, the data bus keeps its previous value. See [Section 13.3.1.4.8.10, Bus Keeping Support](#).

13.3.1.4.9.1.3 Asynchronous Multiple (Page) Write Operation on an Address/Data-Multiplexed Device

Write multiple (page) access in asynchronous mode is not supported for address/data-multiplexed devices.

If the GPMC_CONFIG1_i[28] WRITEMULTIPLE bit is enabled (0x1) with the GPMC_CONFIG1_i[27] WRITETYPE bit as asynchronous (0x0), the GPMC processes single asynchronous accesses.

For accesses on non-multiplexed devices, see [Section 13.3.1.4.9.3, Asynchronous and Synchronous Accesses in non-multiplexed Mode.](#)

13.3.1.4.9.1.2 Access on Address/Address/Data-Multiplexed Devices

13.3.1.4.9.1.2.1 Asynchronous Single Read Operation on an AAD-Multiplexed Device

Figure 13-141 shows an asynchronous single-read operation on an AAD-multiplexed device.

ADVANCE INFORMATION

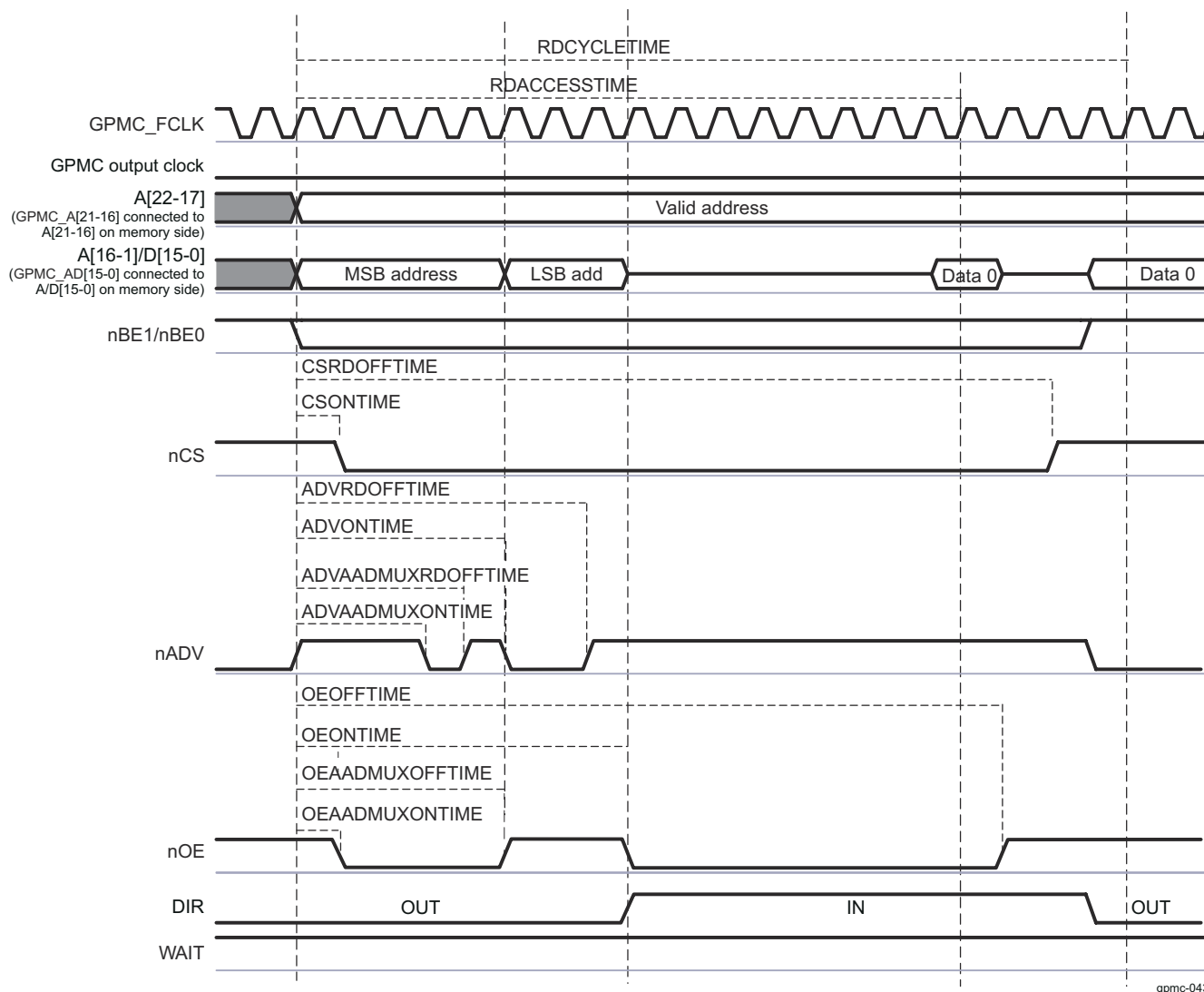

Figure 13-141. Asynchronous Single Read on an AAD-Multiplexed Device

For formulas to calculate timing parameters, see [Section 13.3.1.5.6.1, GPMC Timing Parameters Formulas.](#)

[Table 13-206](#) lists the timing bit fields to set up to configure the GPMC in asynchronous single write mode.

When the GPMC generates a read access to an AAD-multiplexed device, all address bits are driven onto the address/data bus in two separate phases. The first phase is used for the MSB address and is qualified with nOE driven low. The first address phase ends at the first nOE deassertion time. The second phase for LSB address

is qualified with nOE driven high. The second address phase ends at the second nOE assertion time, when the DIR signal goes from OUT to IN.

The nCS and DIR signals are controlled in the same way as for an asynchronous single-read operation on an address/data-multiplexed device.

- Address valid signal nADV. nADV is asserted and deasserted twice during a read transaction:
 - nADV first assertion time is controlled by the GPMC_CONFIG3_i[6-4] ADVAADMUXONTIME bit field.
 - nADV first deassertion time is controlled by the GPMC_CONFIG3_i[26-24] ADVAADMUXRDOFFTIME bit field.
 - nADV second assertion time is controlled by the GPMC_CONFIG3_i[3-0] ADVONTIME bit field.
 - nADV second deassertion time is controlled by the GPMC_CONFIG3_i[12-8] ADVRDOFFTIME bit field.
- Output Enable signal nOE. nOE is asserted and deasserted twice during a read transaction (nOE second assertion indicates a read cycle):
 - nOE first assertion time is controlled by the GPMC_CONFIG4_i[6-4] OEAADMUXONTIME bit field.
 - nOE first deassertion time is controlled by the GPMC_CONFIG3_i[15-13] OEAADMUXOFFTIME bit field.
 - nOE second assertion time is controlled by the GPMC_CONFIG4_i[3-0] OEONTIME bit field.
 - nOE second deassertion time is controlled by the GPMC_CONFIG4_i[12-8] OEOFFTIME bit field.

13.3.1.4.9.1.2.2 Asynchronous Single-Write Operation on an AAD-Multiplexed Device

Figure 13-142 shows an asynchronous single-write operation on an AAD-multiplexed device.

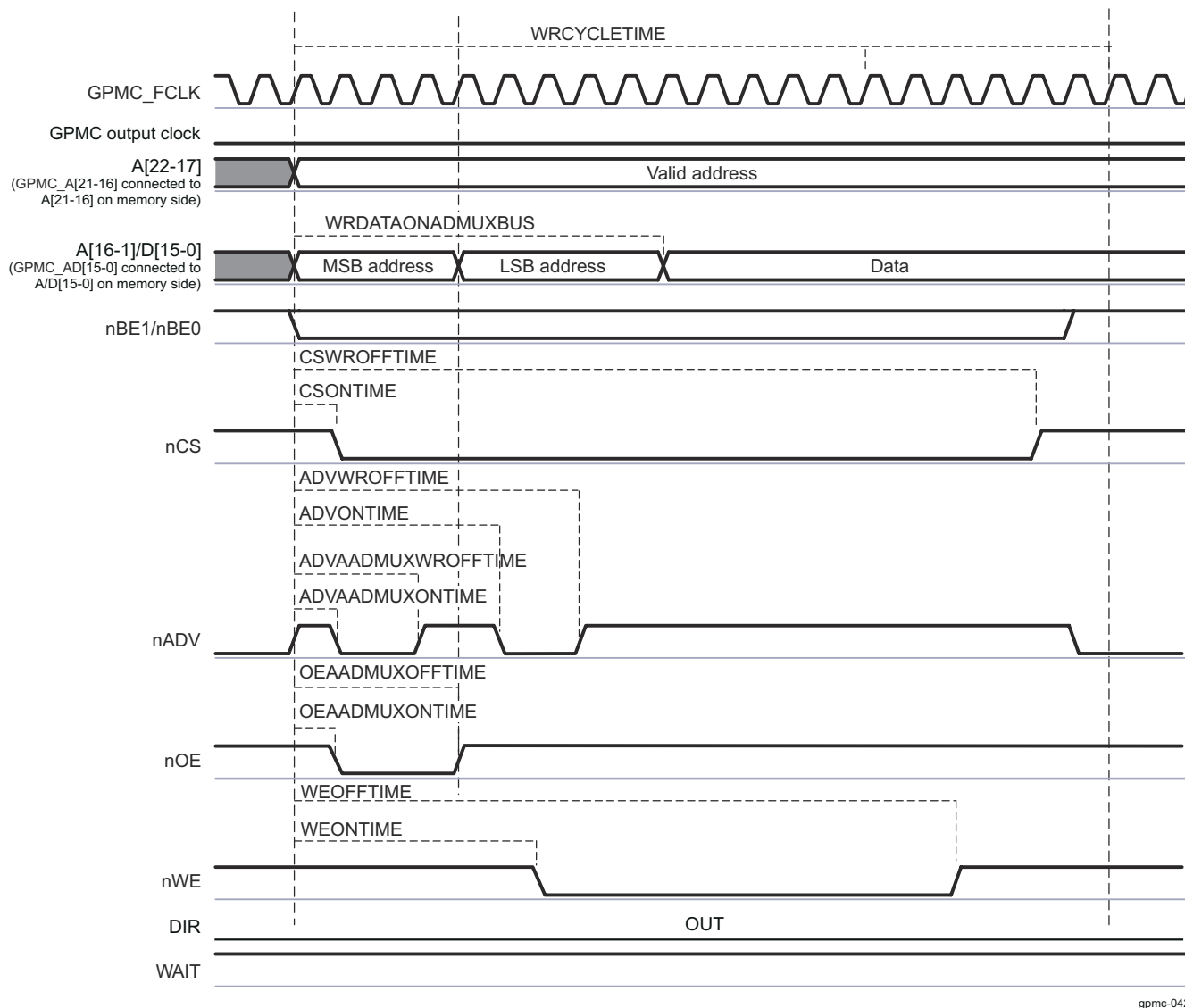

Figure 13-142. Asynchronous Single Write on an AAD-Multiplexed Device

For formulas to calculate timing parameters, see [Section 13.3.1.5.6.1, GPMC Timing Parameters Formulas](#).

[Table 13-206](#) lists the timing bit fields to set up to configure the GPMC in asynchronous single-write mode.

When the GPMC generates a write access to an AAD-multiplexed device, all address bits are driven onto the address/data bus in two separate phases. The first phase is used for the MSB address and is qualified with nOE driven low. The second phase for LSB address is qualified with nOE driven high. The address phase ends at nWE assertion time.

The nCS, nWE, and DIR signals are controlled in the same way as for an asynchronous single-write operation on an address/data-multiplexed device. See [Table 13-197, NAND Memory Type](#).

- Address valid signal nADV is asserted and deasserted twice during a write transaction:
 - nADV first assertion time is controlled by the GPMC_CONFIG3_i[6-4] ADVAADMUXONTIME bit field.
 - nADV first deassertion time is controlled by the GPMC_CONFIG3_i[30-28] ADVAADMUXWROFFTIME bit field.
 - nADV second assertion time is controlled by the GPMC_CONFIG3_i[3-0] ADVONTIME bit field.
 - nADV second deassertion time is controlled by the GPMC_CONFIG3_i[20-16] ADVWROFFTIME bit field.
- Output enable signal nOE is asserted during the address phase of a write transaction:

- nOE assertion time is controlled by the GPMC_CONFIG4_i[6-4] OEAADMUXONTIME bit field.
- nOE deassertion time is controlled by the GPMC_CONFIG3_i[15-13] OEAADMUXOFFTIME bit field.

The address bits for the first address phase are driven onto the data bus until nOE deassertion. Data is driven onto the address/data bus at the clock edge defined by the GPMC_CONFIG6_i[19-16] WRDATAONADMUXBUS parameter.

13.3.1.4.9.1.2.3 Asynchronous Multiple (Page) Read Operation on an AAD-Multiplexed Device

Write multiple (page) access in asynchronous mode is not supported for AAD-multiplexed devices.

If the GPMC_CONFIG1_i[28] WRITEMULTIPLE bit is enabled (0x1) with the GPMC_CONFIG1_i[27] WRITETYPE bit as asynchronous (0x0), the GPMC processes single asynchronous accesses.

For accesses on non-multiplexed devices, see [Section 13.3.1.4.9.3, Asynchronous and Synchronous Accessed in non-multiplexed Mode](#).

13.3.1.4.9.2 Synchronous Access Description

This section describes read and write synchronous accesses on address/data-multiplexed devices. All information in this section can be applied to any type of memory (non-multiplexed, address and data-multiplexed, or AAD-multiplexed) with the difference limited to the address phase. For accesses on non-multiplexed devices, see [Section 13.3.1.4.9.3, Asynchronous and Synchronous Accessed in non-multiplexed Mode](#).

In synchronous operations:

- The GPMC_CLKOUT clock is provided outside the GPMC when accessing the memory device.
- The GPMC_CLKOUT clock is derived from the GPMC_FCLK clock using the GPMC_CONFIG1_i[1-0] GPMCFCLKDIVIDER bit field. In the following section *i* stands for the chip-select number, *i* = 0 to 3.
- The GPMC_CONFIG1_i[26-25] CLKACTIVATIONTIME bit field specifies that the GPMC_CLKOUT is provided outside the GPMC for 0 to 2 GPMC_FCLK cycles after start access time until RDCYCLETIME or WRCYCLETIME completes.

13.3.1.4.9.2.1 Synchronous Single Read

[Figure 13-143](#) and [Figure 13-144](#) show a synchronous single-read operation with GPMCFCLKDIVIDER equal to 0 and 1, respectively.

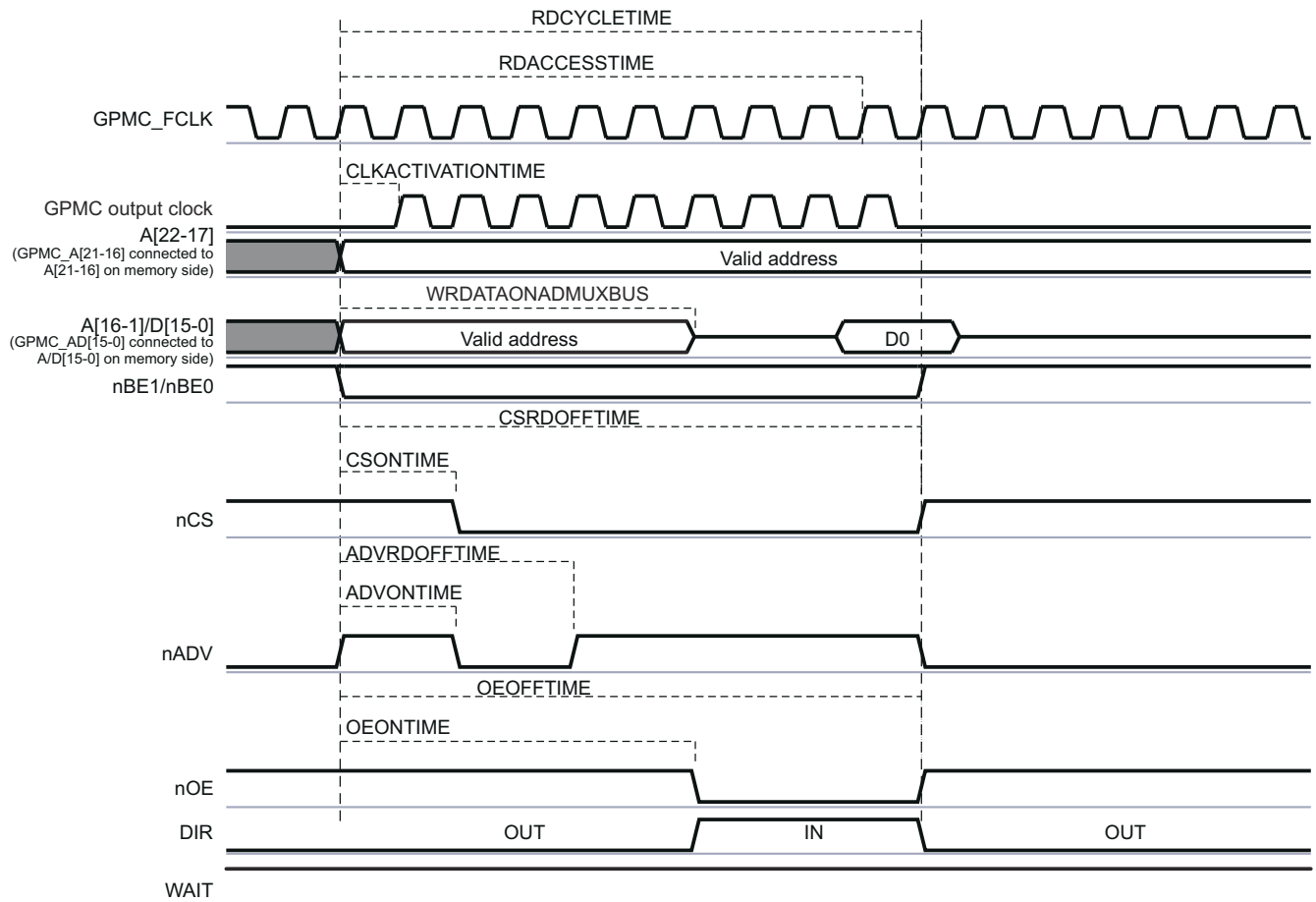

gpmc-015

Figure 13-143. Synchronous Single Read (GPMCFCLKDIVIDER = 0)

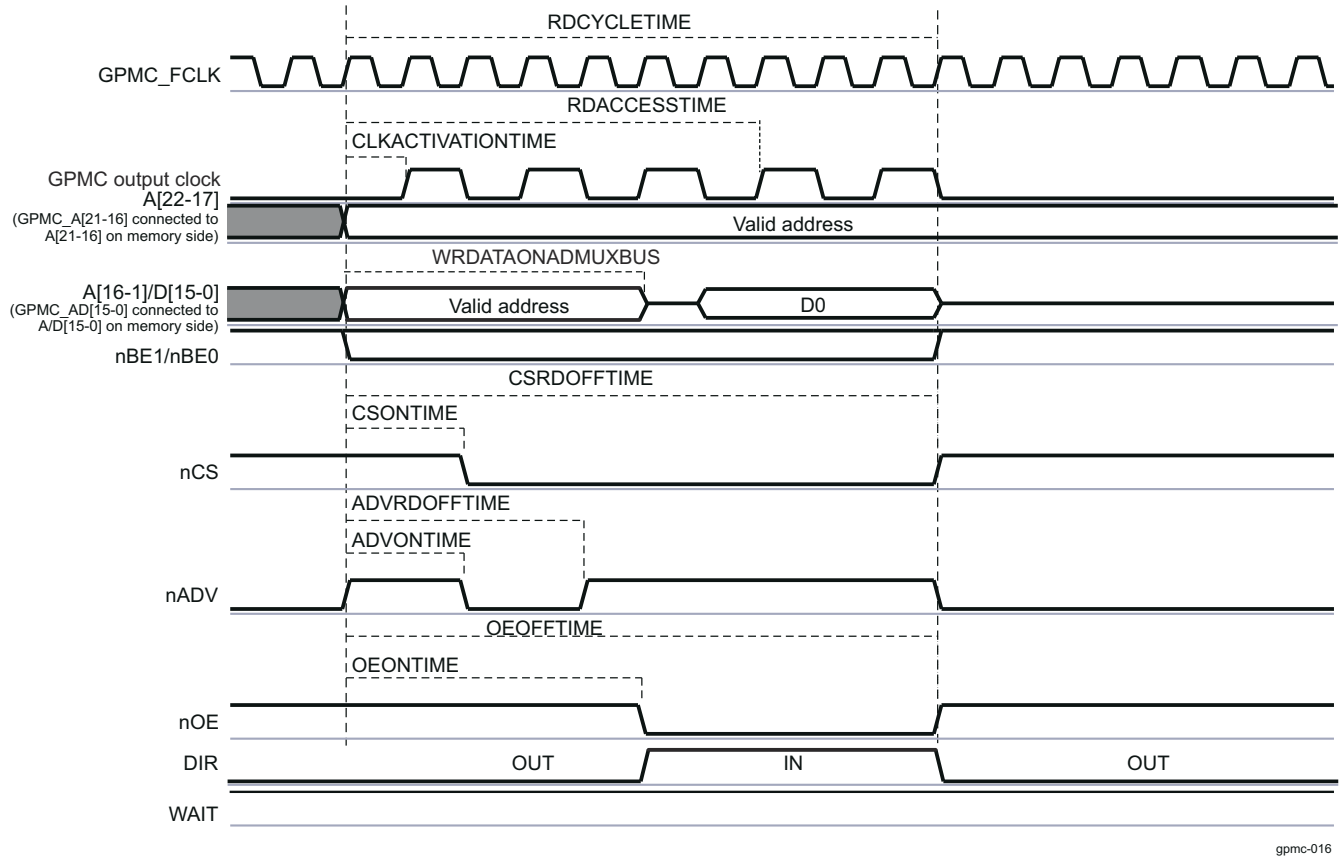

gpmc-016

Figure 13-144. Synchronous Single Read (GPMCFCLKDIVIDER = 1)

For formulas to calculate timing parameters, see [Section 13.3.1.5.6.1, GPMC Timing Parameters Formulas](#).

[Table 13-206](#) lists the timing bit fields to set up to configure the GPMC in asynchronous single-read mode.

When the GPMC generates a read access to an address/data-multiplexed device, it drives the address bus until nOE assertion time. For more information, see [Section 13.3.1.4.7.2.3, Address/Data-Multiplexing Interface](#).

- Chip-select signal nCS:
 - nCS assertion time is controlled by the GPMC_CONFIG2_i[3-0] CSONTIME bit field and ensures address setup time to nCS assertion.
 - nCS deassertion time is controlled by the GPMC_CONFIG2_i[12-8] CSRDOFFTIME bit field and ensures address hold time to nCS deassertion.
- Address valid signal nADV:
 - nADV assertion time is controlled by the GPMC_CONFIG3_i[3-0] ADVONTIME bit field.
 - nADV deassertion time is controlled by the GPMC_CONFIG3_i[12-8] ADVRDOFFTIME bit field.
- Output enable signal nOE:
 - nOE assertion indicates a read cycle.
 - nOE assertion time is controlled by the GPMC_CONFIG4_i[3-0] OEONTIME bit field.
 - nOE deassertion time is controlled by the GPMC_CONFIG4_i[12-8] OEOFFTIME bit field.
- Initial latency for the first read data is controlled by GPMC_CONFIG5_i[20-16] RDACCESSTIME bit field or by monitoring the WAIT signal.
- Total access time (the GPMC_CONFIG5_i[4-0] RDCYCLETIME bit field) corresponds to RDACCESSTIME plus the address hold time from nCS deassertion, plus time from RDACCESSTIME to CSRDOFFTIME.
- Direction signal DIR: DIR goes from OUT to IN at the same time as nOE assertion.

When the GPMC generates a write access to an AAD-multiplexed device, all address bits are driven onto the address/data bus in two separate phases. The first phase is used for the MSB address and is qualified with nOE

driven low. The second phase for LSB address is qualified with nOE driven high. The address phase ends at nWE assertion time.

The nCS and DIR signals are controlled in the same way as for a synchronous single-read operation on an address/data-multiplexed device.

- Address valid signal nADV is asserted and deasserted twice during a read transaction:
 - nADV first assertion time is controlled by the GPMC_CONFIG3_i[6-4] ADVAADMUXONTIME bit field.
 - nADV first deassertion time is controlled by the GPMC_CONFIG3_i[26-24] ADVAADMUXRDOFFTIME bit field.
 - nADV second assertion time is controlled by the GPMC_CONFIG3_i[3-0] ADVONTIME bit field.
 - nADV second deassertion time is controlled by the GPMC_CONFIG3_i[12-8] ADVRDOFFTIME bit field.
- Output Enable signal nOE is asserted and deasserted twice during a read transaction (nOE second assertion indicates a read cycle):
 - nOE first assertion time is controlled by the GPMC_CONFIG4_i[6-4] OEAADMUXONTIME bit field.
 - nOE first deassertion time is controlled by the GPMC_CONFIG3_i[15-13] OEAADMUXOFFTIME bit field.
 - nOE second assertion time is controlled by the GPMC_CONFIG4_i[3-0] OEONTIME bit field.
 - nOE second deassertion time is controlled by the GPMC_CONFIG4_i[12-8] OEOFFTIME bit field.

After a read operation, if no other access (read or write) is pending, the data bus is driven with the previous read value. See [Section 13.3.1.4.8.10, Bus Keeping Support](#).

13.3.1.4.9.2.2 Synchronous Multiple (Burst) Read (4-, 8-, 16-Word16 Burst With Wraparound Capability)

[Figure 13-145](#) and [Figure 13-146](#) show a synchronous multiple-read operation with GPMCFCLKDivider equal to 0 and 1, respectively.

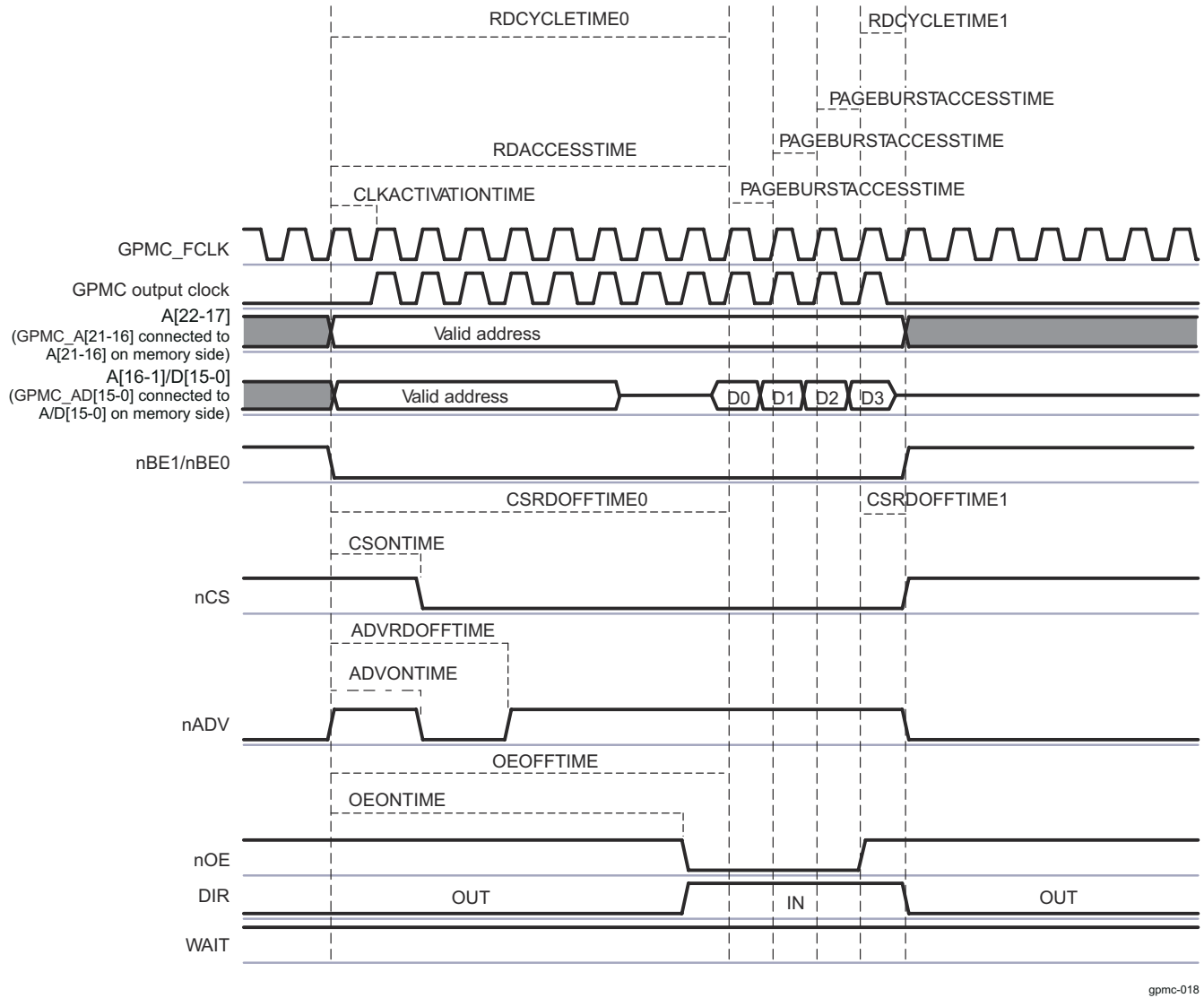

ADVANCE INFORMATION

gpmc-018

Figure 13-145. Synchronous Multiple (Burst) Read (GPMCFCLKDIVIDER = 0)

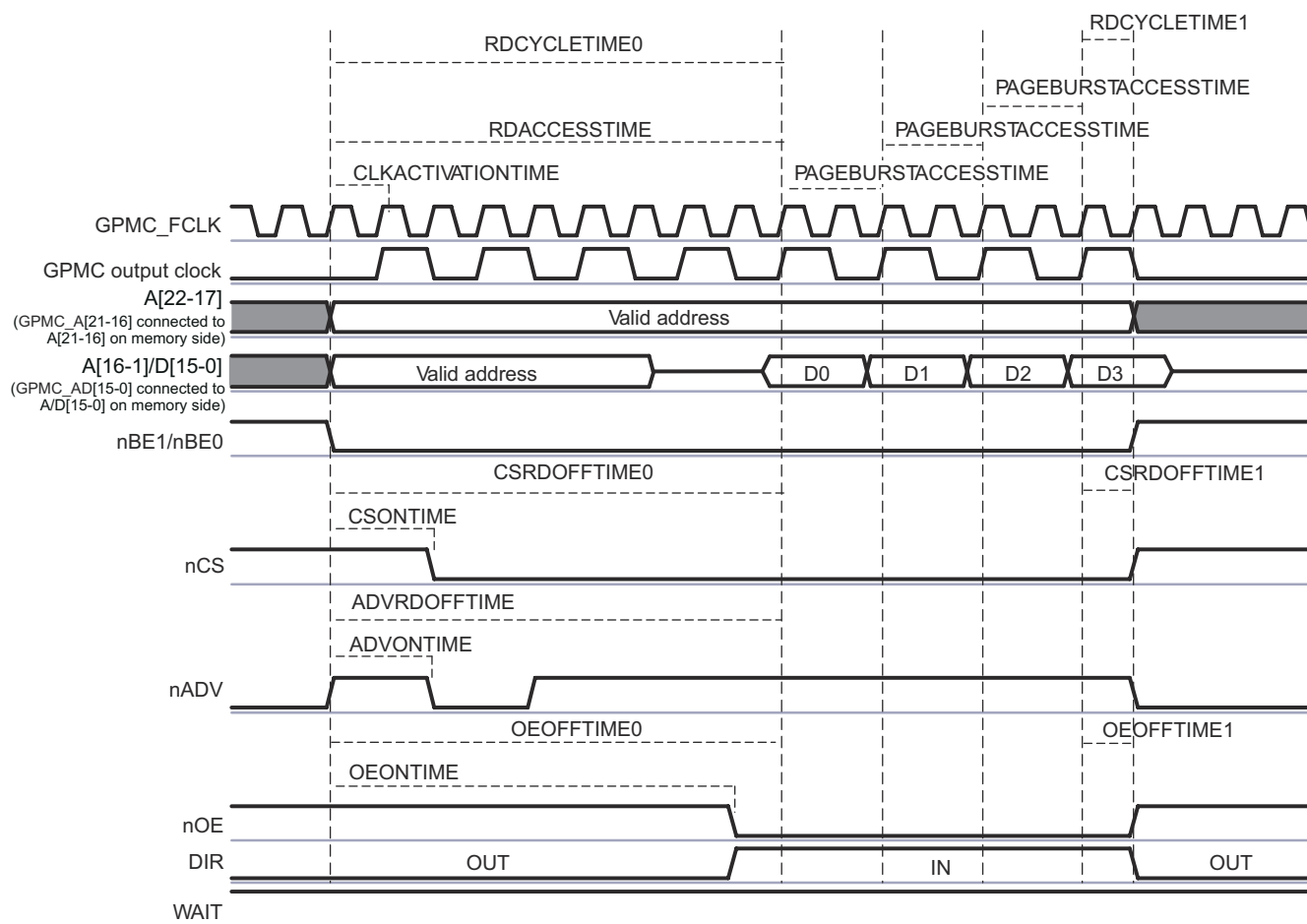

gpmc-019

Figure 13-146. Synchronous Multiple (Burst) Read (GPMCFCLKDIVIDER = 1)

When the GPMC_CONFIG5_i[20-16] RDACCESSTIME bit field completes, control-signal timings are frozen during the multiple data transactions, corresponding to the GPMC_CONFIG5_i[27-24] PAGEBURSTACCESSTIME bit field multiplied by the number of remaining data transactions.

The nCS, nADV, nOE, and DIR signals are controlled in the same way as for a synchronous single-read operation. See [Table 13-192, NOR Memory Type](#).

Initial latency for the first read data is controlled by RDACCESSTIME or by monitoring the WAIT signal. Successive read data are provided by the memory device every one or two GPMC_CLKOUT cycles. The PAGEBURSTACCESSTIME parameter must be set accordingly with the GPMC_CONFIG1_i[1-0] GPMCFCLKDIVIDER bit field and the memory-device internal configuration. Depending on the device page length, the GPMC checks the device page crossing during a new burst request and purposely inserts initial latency (of RDACCESSTIME) when required.

Total access time GPMC_CONFIG5_i[4-0] RDCYCLETIME corresponds to RDACCESSTIME plus the address hold time from nCS deassertion. In [Figure 13-146](#), the programmed value of RDCYCLETIME equals RDCYCLETIME0 + RDCYCLETIME1.

After a read operation, if no other access (read or write) is pending, the data bus is driven with the previous read value. See [Section 13.3.1.4.8.10, Bus Keeping Support](#).

Burst wraparound is enabled through the GPMC_CONFIG1_i[31] WRAPBURST bit and allows a 4-, 8-, or 16-Word16 linear burst access to wrap within its burst-length boundary through the GPMC_CONFIG1_i[24-23] ATTACHEDDEVICEPAGELENGTH bit field.

13.3.1.4.9.2.3 Synchronous Single Write

Burst write mode is used for synchronous single or burst accesses.

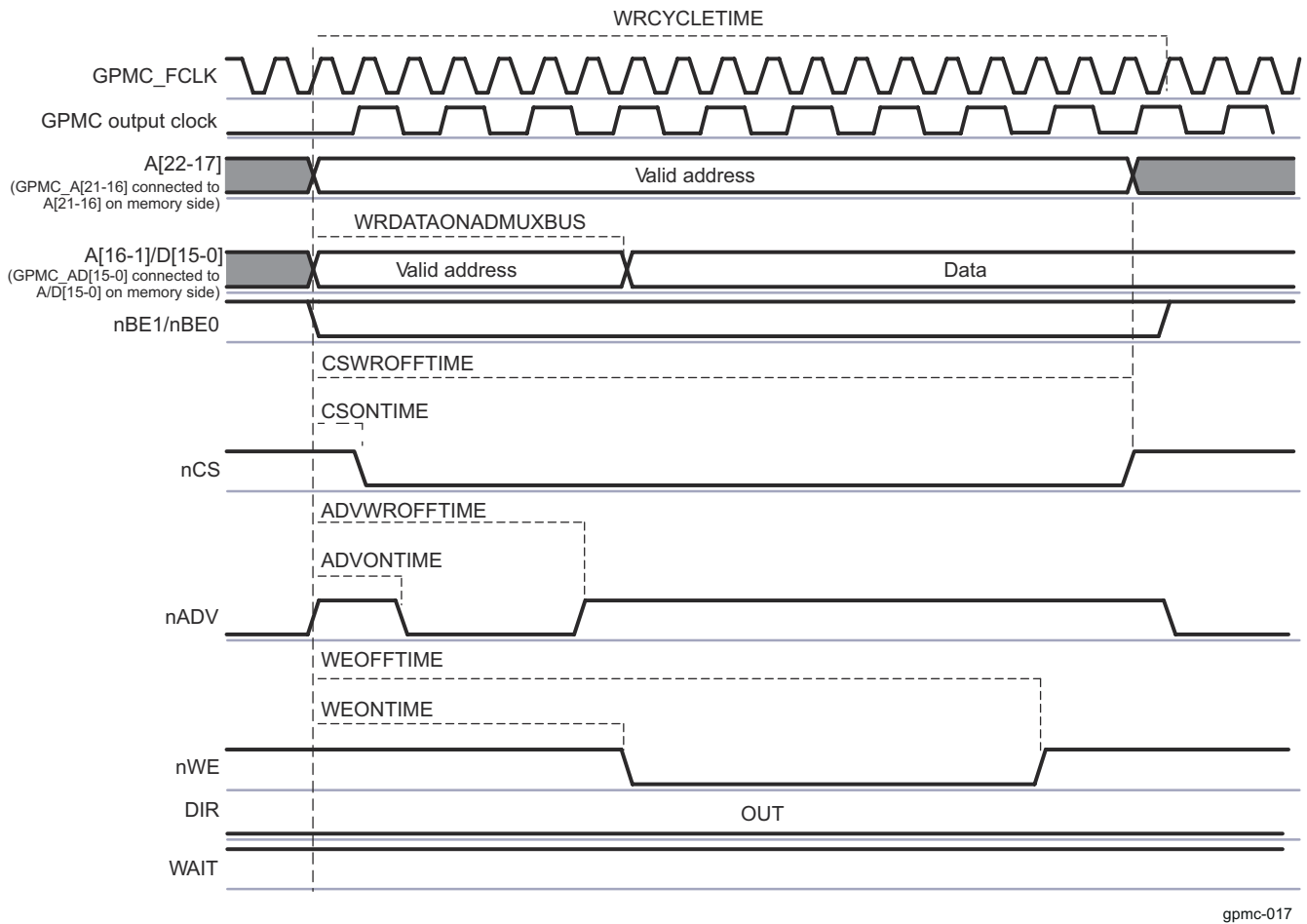

Figure 13-147. Synchronous Single Write on an Address/Data-Multiplexed Device

When the GPMC generates a write access to an address/data-multiplexed device, it drives the data bus (with address bits A[16-1]) until the GPMC_CONFIG6_i[19-16] WRDATAONADMUXBUS bit field time. The first data of the burst is driven on the address/data bus at WRDATAONADMUXBUS time.

13.3.1.4.9.2.4 Synchronous Multiple (Burst) Write

Synchronous burst write mode provides synchronous single or consecutive accesses.

Figure 13-148 shows a synchronous burst write access when the chip-select is configured in address/data-multiplexed mode.

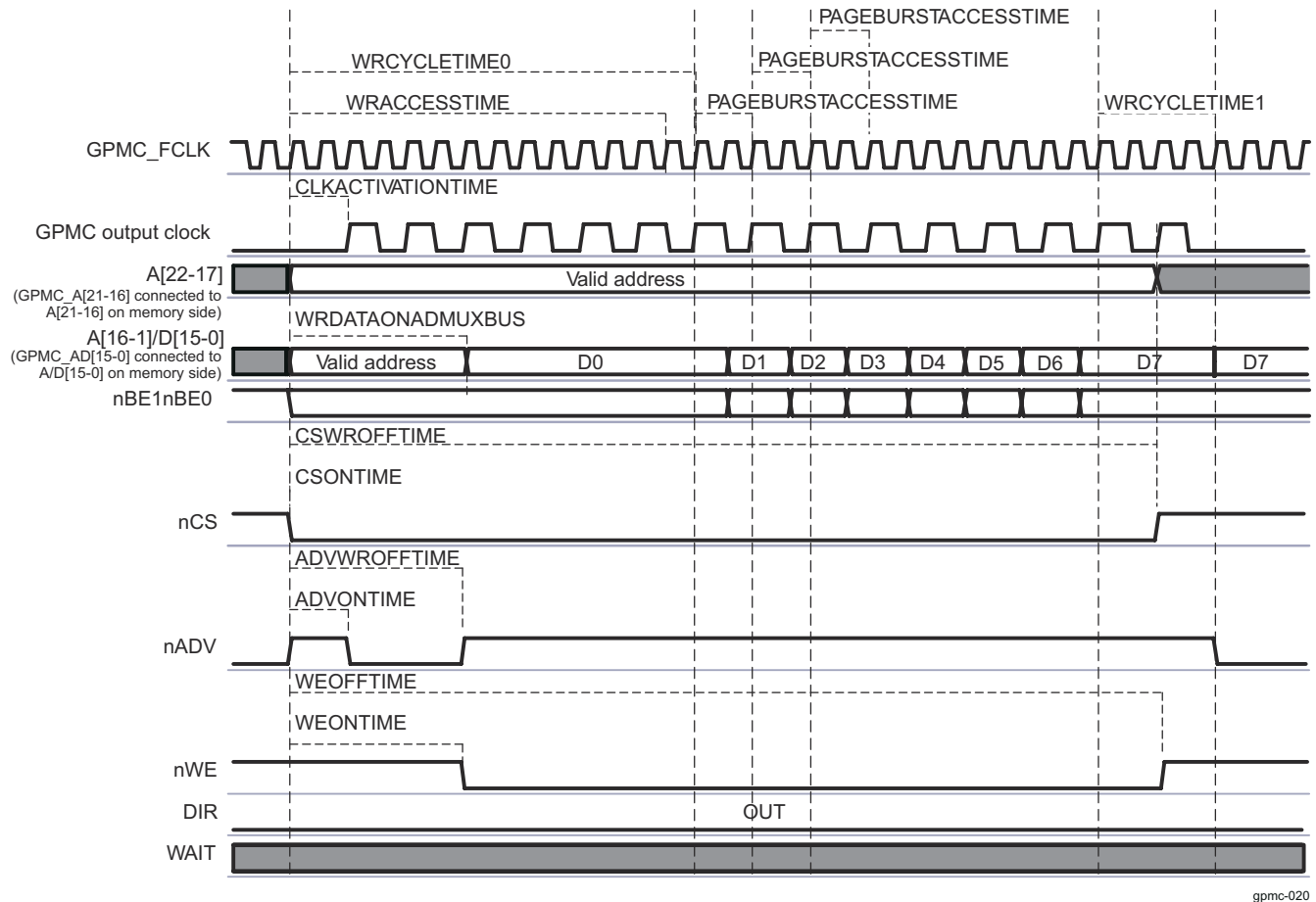

Figure 13-148. Synchronous Multiple Write (Burst Write) in Address/Data-Multiplexed Mode

Figure 13-149 shows the same synchronous burst write access when the chip-select is configured in address/address/data-multiplexed (AAD-multiplexed) mode.

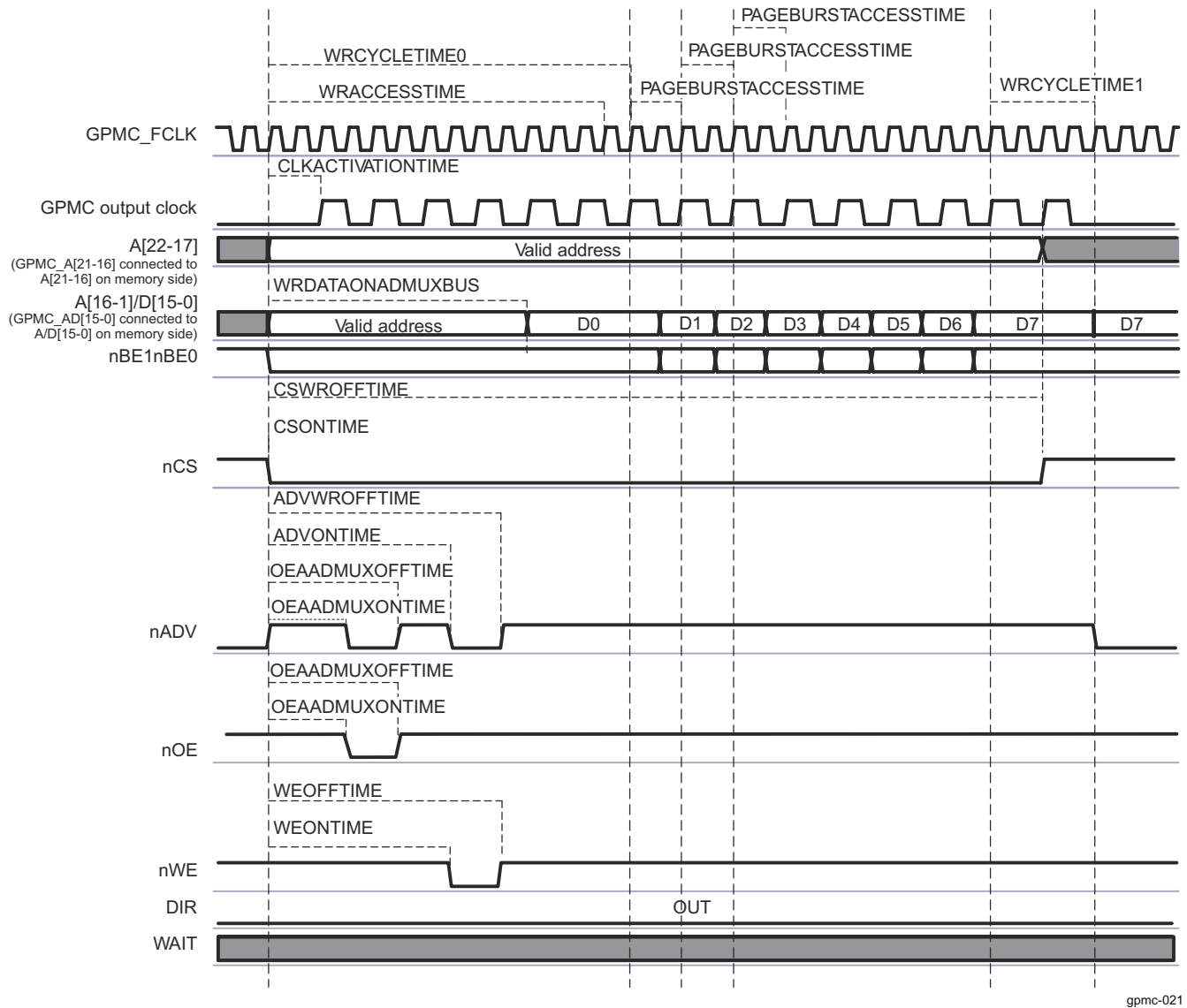

Figure 13-149. Synchronous Multiple Write (Burst Write) in Address/Address/Data-Multiplexed Mode

The first data of the burst is driven on the A/D bus at the GPMC_CONFIG6_i[19-16] WRDATAONADMUXBUS bit field.

When WRACCESTIME completes, control-signal timings are frozen during the multiple data transactions, corresponding to the GPMC_CONFIG5_i[27-24] PAGEBURSTACCESTIME bit field multiplied by the number of remaining data transactions.

When the GPMC generates a read access to an address/data-multiplexed device, it drives the address bus until nOE assertion time. For more information, see [Section 13.3.1.4.7.2.3, Address/Data-Multiplexing Interface](#).

- Chip-select signal nCS:
 - nCS assertion time is controlled by the GPMC_CONFIG2_i[3-0] CSONTIME bit field (where i = 0 to 3) and ensures address setup time to nCS assertion.
 - nCS deassertion time controlled by the GPMC_CONFIG2_i[20-16] CSWROFFTIME bit field and ensures address hold time to nCS deassertion.
- Address valid signal nADV:
 - nADV assertion time is controlled by the GPMC_CONFIG3_i[3-0] ADVONTIME bit field.
 - nADV deassertion time is controlled by the GPMC_CONFIG3_i[20-16] ADVWROFFTIME bit field.

- Write enable signal nWE:
 - nWE assertion indicates a read cycle.
 - nWE assertion time is controlled by the GPMC_CONFIG4_i[19-16] WEONTIME bit field.
 - nWE deassertion time is controlled by the GPMC_CONFIG4_i[28-24] WEOFFTIME bit field.

Note

The nWE falling edge must not be used to control the time when the burst first data is driven in the address/data bus, because some new devices require the nWE signal to be low during the address phase.

- Direction signal DIR is OUT during the entire access.

When the GPMC generates a write access to an AAD-multiplexed device, all address bits are driven onto the address/data bus in two separate phases. The first phase is used for the MSB address and is qualified with nOE driven low. The second phase for LSB address is qualified with nOE driven high. The address phase ends at nWE assertion time.

The nCS, and DIR signals are controlled as previously described.

- Address valid signal nADV is asserted and deasserted twice during a read transaction:
 - nADV first assertion time is controlled by the GPMC_CONFIG3_i[6-4] ADVAADMUXONTIME bit field.
 - nADV first deassertion time is controlled by the GPMC_CONFIG3_i[26-24] ADVAADMUXRDOFFTIME bit field.
 - nADV second assertion time is controlled by the GPMC_CONFIG3_i[3-0] ADVONTIME bit field.
 - nADV second deassertion time is controlled by the GPMC_CONFIG3_i[12-8] ADVRDOFFTIME bit field.
- Output Enable signal nOE is asserted and deasserted twice during a read transaction (nOE second assertion indicates a read cycle):
 - nOE first assertion time is controlled by the GPMC_CONFIG4_i[6-4] OEAADMUXONTIME bit field.
 - nOE first deassertion time is controlled by the GPMC_CONFIG4_i[15-13] OEAADMUXOFFTIME bit field.
 - nOE second assertion time is controlled by the GPMC_CONFIG4_i[3-0] OEONTIME bit field.
 - nOE second deassertion time is controlled by the GPMC_CONFIG4_i[12-8] OEOFFTIME bit field.

First write data is driven by the GPMC at GPMC_CONFIG6_i[19-16] WRDATAONADMUXBUS, when in address/data-multiplexed configuration. The next write data of the burst is driven on the bus at WRACCESSTIME + 1 during GPMC_CONFIG5_i[27-24] PAGEBURSTACCESSTIME GPMC_FCLK cycles. The last data of the synchronous burst write is driven until GPMC_CONFIG5_i[12-8] WRCYCLETIME completes.

- WRACCESSTIME is defined in the GPMC_CONFIG6_i[28-24] bit field.
- The PAGEBURSTACCESSTIME parameter must be set accordingly with GPMCFCLKDIVIDER and the memory-device internal configuration.

Total access time GPMC_CONFIG5_i[12-8] WRCYCLETIME corresponds to WRACCESSTIME plus the address hold time from nCS deassertion. In [Figure 13-148](#), the programmed value of WRCYCLETIME equals WRCYCLETIME0 + WRCYCLETIME1. WRCYCLETIME0 and WRCYCLETIME1 delays are not actual parameters and are only a graphical representation of the full WRCYCLETIME value.

After a write operation, if no other access (read or write) is pending, the data bus keeps the previous value. See [Section 13.3.1.4.8.10, Bus Keeping Support](#).

13.3.1.4.9.3 Asynchronous and Synchronous Accesses in non-multiplexed Mode

Page mode is available only in non-multiplexed mode.

- Asynchronous single-read operation on a non-multiplexed device
- Asynchronous single-write operation on a non-multiplexed device
- Asynchronous multiple- (page mode) read operation on a non-multiplexed device
- Synchronous operations on a non-multiplexed device

13.3.1.4.9.3.1 Asynchronous Single-Read Operation on non-multiplexed Device

[Figure 13-150](#) shows an asynchronous single-read operation on a non-multiplexed device.

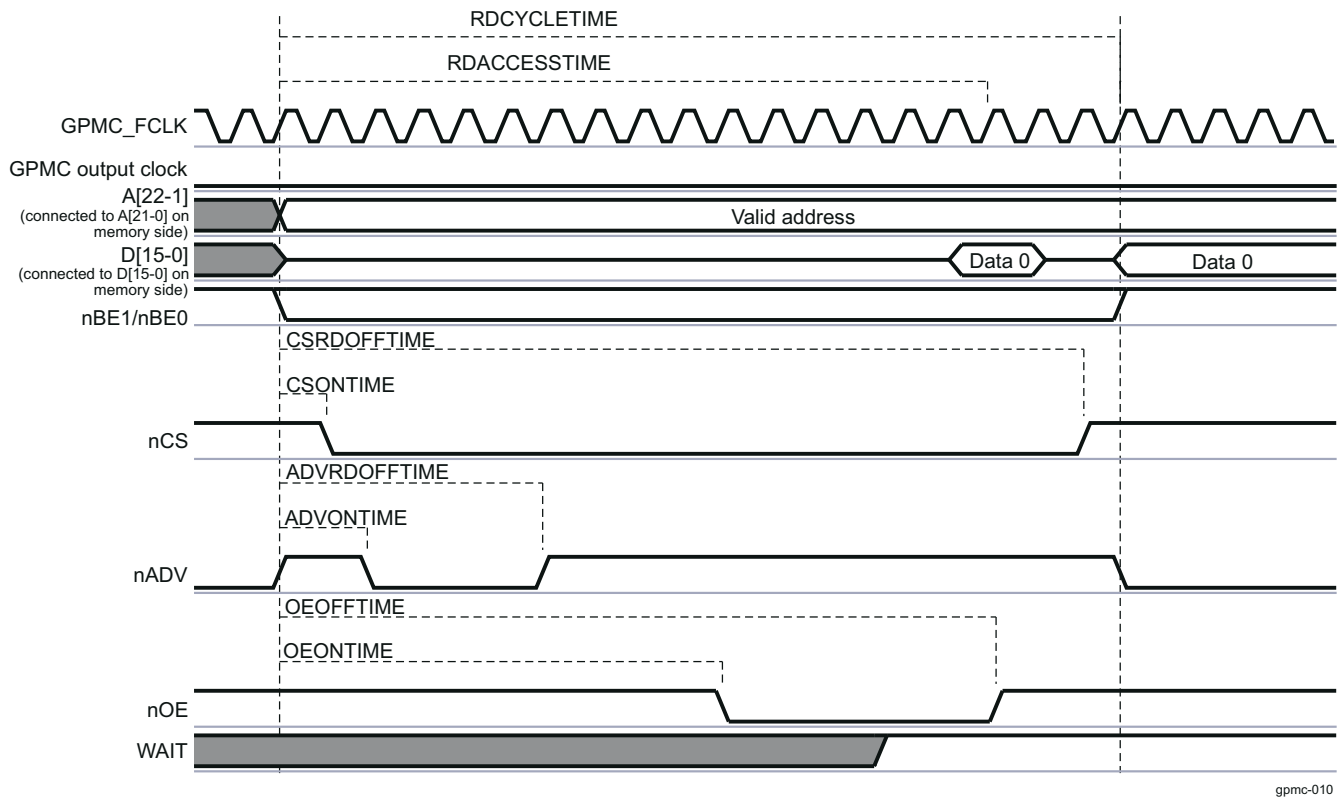

Figure 13-150. Asynchronous Single Read on an Address/Data-non-multiplexed Device

The 22-bit address (For a 16-bit data memory device, hence GPMC A[0] is not necessary to be output) is driven onto the address bus A[22-1] and the 16-bit data is driven onto the data bus D[15-0].

Read data is latched at GPMC_CONFIG1_5[20-16] RDACCESSTIME completion time. The end of the access is defined by the GPMC_CONFIG1_5[4-0] RDCYCLETIME parameter.

The nCS, nADV, nOE, and DIR signals are controlled in the same way as address/data-multiplexed accesses (see Table 13-197, NAND Memory Type).

13.3.1.4.9.3.2 Asynchronous Single-Write Operation on non-multiplexed Device

Figure 13-151 shows an asynchronous single-write operation on a non-multiplexed device.

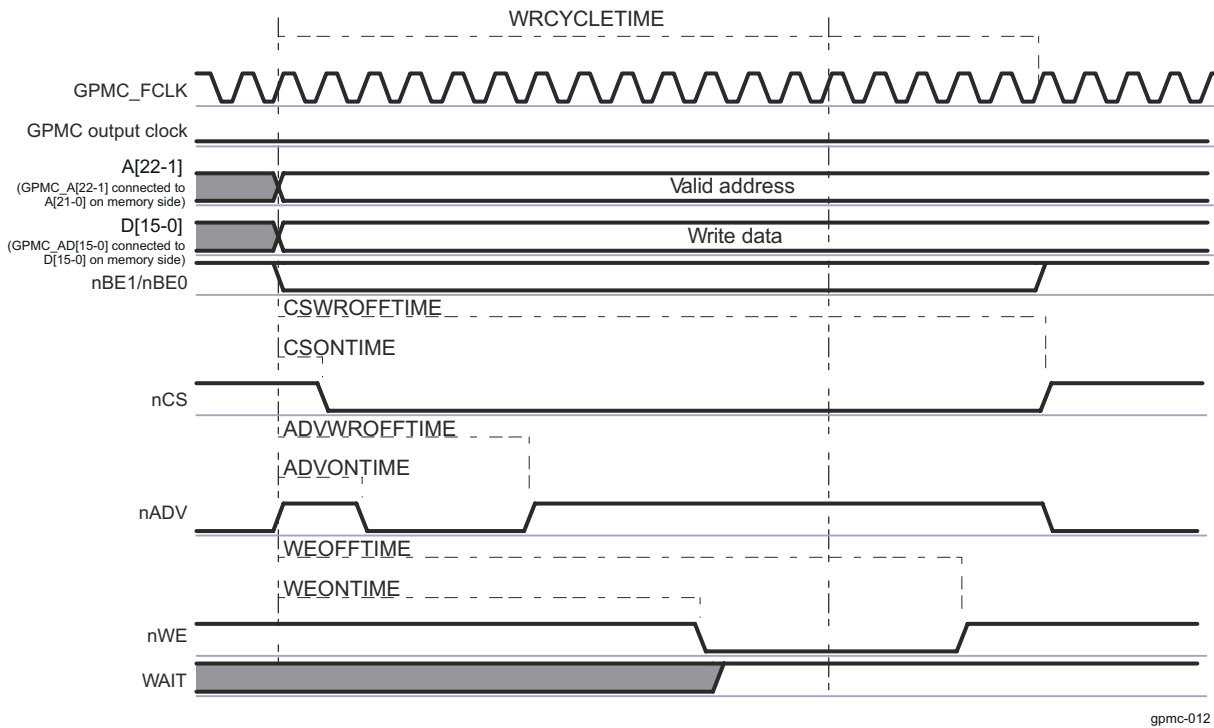

Figure 13-151. Asynchronous Single Write on an Address/Data-non-multiplexed Device

The nCS, nADV, nWE, and DIR signals are controlled in the same way as address/data-multiplexed accesses (see [Table 13-197](#)).

13.3.1.4.9.3.3 Asynchronous Multiple (Page Mode) Read Operation on non-multiplexed Device

[Figure 13-152](#) shows an asynchronous multiple-read operation on a non-multiplexed device in which two word32 host read accesses to the GPMC are split into one multiple- (page mode of 4 word16) read access to the attached device.

ADVANCE INFORMATION

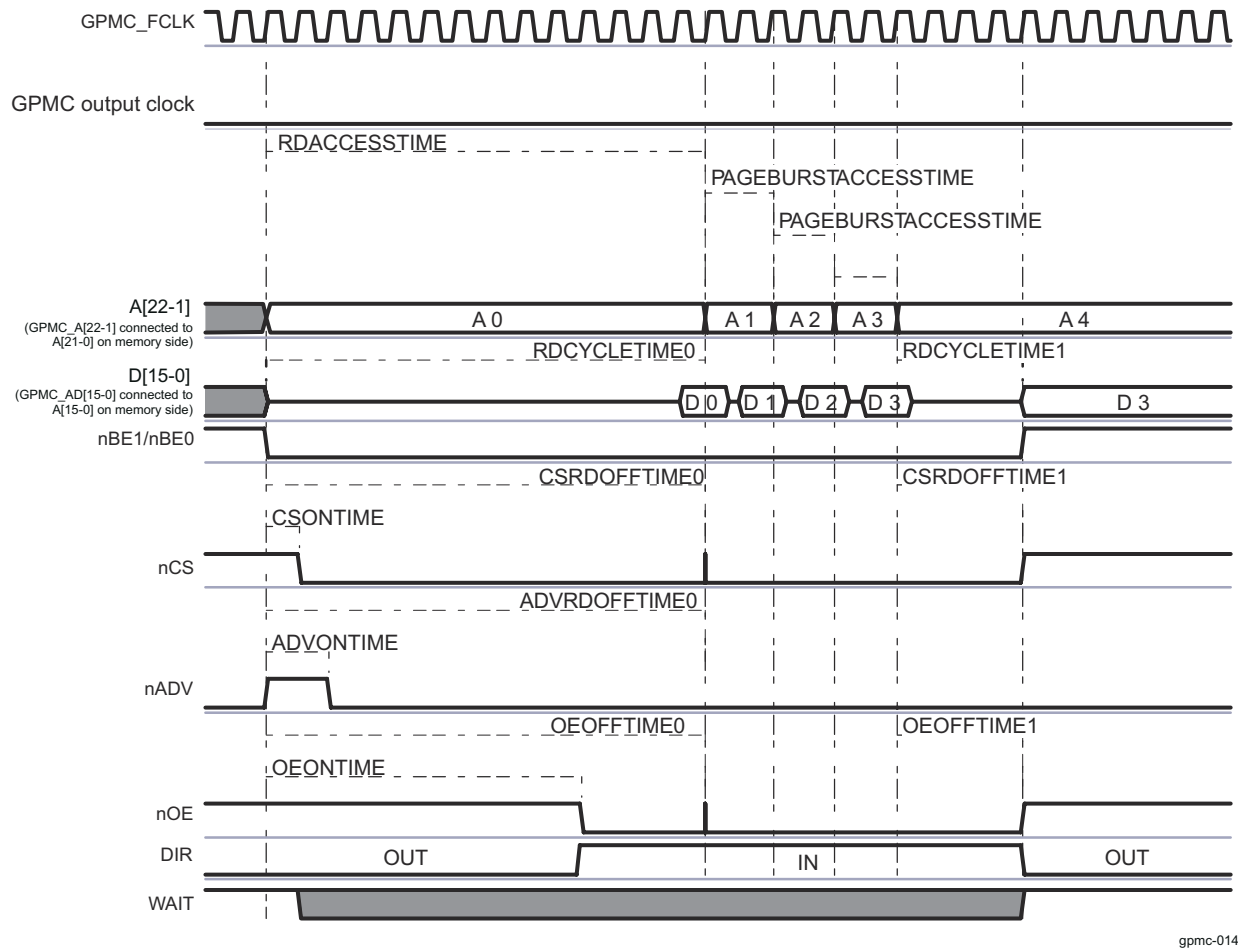

Figure 13-152. Asynchronous Multiple (Page Mode) Read

gpmc-014

ADVANCE INFORMATION

Note

The WAIT signal is active low.

The nCS, nADV, nOE, and DIR signals are controlled in the same way as address/data-multiplexed accesses (see Table 13-197).

When RDACCESSTIME completes, control signal timings are frozen during the multiple data transactions, corresponding to PAGEBURSTACCESSTIME multiplied by the number of remaining data transactions.

Read data is latched at GPMC_CONFIG5_i[20-16] RDACCESSTIME completion time (where i = 0 to 3). The end of the access is defined by the GPMC_CONFIG5_i[4-0] RDCYCLETIME parameter.

During consecutive accesses, the GPMC increments the address after each data read completes.

Delay between successive read data in the page is controlled by the GPMC_CONFIG5_i[27-24] PAGEBURSTACCESSTIME parameter. Depending on the device page length, the GPMC can control device page crossing during a burst request and insert initial RDACCESSTIME latency. Page crossing is possible only with a new burst access, meaning a new initial access phase is initiated.

Total access time RDCYCLETIME corresponds to RDACCESSTIME, plus the address hold time, starting from the nCS deassertion.

- The read cycle time is defined in the GPMC_CONFIG5_i[4-0] RDCYCLETIME bit field.
- In Figure 13-152, the programmed value of RDCYCLETIME equals RDCYCLETIME0 (before paged accesses) + RDCYCLETIME1 (after paged accesses).

13.3.1.4.9.3.4 Synchronous Operations on a non-multiplexed Device

All information for this section is equivalent to similar operations for address/data-multiplexed or AAD-multiplexed accesses. The only difference resides in the address phase. See [Section 13.3.1.5.3, GPMC Configuration in NOR Mode](#).

13.3.1.4.9.4 Page and Burst Support

Each chip-select can be configured to process system single or burst requests into successive single accesses or asynchronous page/synchronous burst accesses, with appropriate access size adaptation.

Depending on the external device page or burst capability, read and write accesses can be independently configured through the GPMC. The GPMC_CONFIG1_][30] READMULTIPLE and GPMC_CONFIG1_][28] WRITEMULTIPLE bits (where $i = 0$ to 3) are associated with the READTYPE and WRITETYPE parameters.

Note

- Asynchronous write page mode is not supported.
- 8-bit-wide device support is limited to nonburstable devices (READMULTIPLE and WRITEMULTIPLE are ignored).
- Not applicable to NAND device interfacing.

13.3.1.4.9.5 System Burst vs External Device Burst Support

The device system can issue the following requests to the GPMC:

- Byte, 16-bit word, 32-bit word requests (byte-enable-controlled). This is always a single request from the interconnect point of view.
- Incrementing fixed-length bursts of two, four, and eight words
- Wrapped (critical word access first) fixed-length burst of two, four, or eight words

To process a system request with the optimal protocol, the READMULTIPLE (and READTYPE) and WRITEMULTIPLE (and WRITETYPE) parameters must be set according to the burstable capability (synchronous or asynchronous) of the attached device.

The GPMC access engine issues only fixed-length bursts. The maximum length that can be issued is defined per chip-select by the GPMC_CONFIG1_][24-23] ATTACHEDDEVICEPAGELENGTH bit field (where $i = 0$ to 3). When the value of ATTACHEDDEVICEPAGELENGTH is less than the length of the system burst request (including the appropriate access size adaptation according to the device width), the GPMC splits the system burst request into multiple bursts. Within the specified 4-, 8-, or 16-word value, the value of the ATTACHEDDEVICEPAGELENGTH bit field must correspond to the maximum length burst supported by the memory device configured in fixed-length burst mode (as opposed to continuous burst mode).

To get optimal performance from memory devices that natively support 16 Word16-length-wrapping burst capability (critical word access first), the ATTACHEDDEVICEPAGELENGTH parameter must be set to 16 words and the GPMC_CONFIG1_][31] WRAPBURST bit (where $i = 0$ to 3) must be set to 1. Similarly DEVICEPAGELENGTH is set to 4 and 8 for memories supporting 4 and 8 Word16-length-wrapping burst, respectively.

When the memory device does not offer (or is not configured to offer) native 16 Word16-length-wrapping burst, the WRAPBURST parameter must be cleared, and the GPMC access engine emulates the wrapping burst by issuing the appropriate burst sequences according to the value of ATTACHEDDEVICEPAGELENGTH.

When the memory device does not support native-wrapping burst, there is usually no difference in behavior between a fixed-burst length mode and a continuous-burst mode configuration (except for a potential power increase from a memory-speculative data prefetch in a continuous burst read). However, even though continuous burst mode is compatible with GPMC behavior, because the GPMC access engine issues only fixed-length burst and does not benefit from continuous burst mode, it is best to configure the memory device in fixed-length burst mode.

The memory device maximum-length burst (configured in fixed-length burst wrap or nonwrap mode) usually corresponds to the memory device data buffer size. Memory devices with a minimum of 16 half-word buffers are the most appropriate (especially with wrap support), but memory devices with smaller buffer size (4 or 8) are also supported, assuming that the GPMC_CONFIG1_i[24-23] ATTACHEDDEVICEPAGELENGTH bit field is set accordingly to 4 or 8 words.

The device system issues only requests with addresses or starting addresses for nonwrapping burst requests; that is, the request size boundary is aligned. In case of an eight-word-wrapping burst, the wrapping address always occurs on the eight-word boundary. As a consequence, all words requested must be available from the memory data buffer when the buffer size is equal to or greater than the value of ATTACHEDDEVICEPAGELENGTH. This usually means that data can be read from or written to the buffer at a constant rate (number of cycles between data) without wait-states between data accesses. If the memory does not behave this way (nonzero wait-state burstable memory), WAIT pin monitoring must be enabled to dynamically control data access completion within the burst.

Note

When the system burst request length is less than the value of ATTACHEDDEVICEPAGELENGTH, the GPMC proceeds with the required accesses.

13.3.1.4.10 GPMC pSRAM Access Specificities

pSRAM devices are SRAM-pin-compatible low-power memories that contain a self-refreshed DRAM memory array. The GPMC_CONFIG1_i[11-10] DEVICETYPE bit field (where i = 0 to 3) must be set to 0b00.

The pSRAM device uses the NOR protocol. It supports the following operations:

- Asynchronous single read
- Asynchronous page read
- Asynchronous single write
- Synchronous single read and write
- Synchronous burst read
- Synchronous burst write (not supported by NOR flash memory)

pSRAM devices must be powered up and initialized in a predefined manner according to the specifications of the attached device.

pSRAM devices can be programmed to use either mode: fixed or variable latency. pSRAM devices can automatically schedule autorefresh operations, which force the GPMC to use its WAIT signal capability when read or write operations occur during an internal self-refresh operation, or they can automatically include the autorefresh operation in the access time. These devices do not require additional WAIT signal capability or a minimum nCS high pulse width between consecutive accesses to ensure that the correct internal refresh operation is scheduled.

13.3.1.4.11 GPMC NAND Access Description

NAND (8-bit and 16-bit) memory devices using a standard NAND asynchronous address/data-multiplexing scheme can be supported on any chip-select with the appropriate asynchronous configuration settings.

As for any other type of memory compatible with the GPMC interface, accesses to a chip-select allocated to a NAND device can be interleaved with accesses to chip-selects allocated to other external devices. This interleaved capability limits the system to *chip enable don't care* NAND devices, because the chip-select allocated to the NAND device must be deasserted if accesses to other chip-selects are requested.

13.3.1.4.11.1 NAND Memory Device in Byte or 16-bit Word Stream Mode

NAND devices require correct command and address programming before data array read or write accesses. The GPMC does not include specific hardware to translate a random address system request into a NAND-specific multiphase access. In that sense, GPMC NAND support, as opposed to random memory-map device support, is data stream-oriented (byte or 16-bit word).

The GPMC NAND programming model depends on a software driver for address and command formatting with the correct data address pointer value according to the block and page structure. Because of NAND structure and protocol interface diversity, the GPMC does not support automatic command and address phase programming, and software drivers must access the NAND device ID to ensure that correct command and address formatting are used for the identified device.

NAND device data read and write accesses are achieved through an asynchronous read or write access. The associated chip-select signal timing control must be programmed according to the NAND device timing specification.

Any chip-select region can be qualified as a NAND region to constrain the nADV/ALE signal as ALE (ALE active high, default state value at low) during address program access, and the nBE0/CLE signal as CLE (CLE active high, default state value at low) during command program access. GPMC address lines are not used (the previous value is not changed) during NAND access.

13.3.1.4.11.1.1 Chip-Select Configuration for NAND Interfacing in Byte or Word Stream Mode

The GPMC_CONFIG7_i register (where i = 0 to 3) associated with a NAND device region interfaced in byte or word stream mode can be initialized with a minimum size of 16MB, because any address location in the chip-select memory region can be used to access a NAND data array. The NAND flash protocol specifies an address sequence where address bits are passed through the data bus in a series of write accesses with the ALE pin asserted. After this address phase, all operations are streamed and the system requests address is irrelevant.

CAUTION

To allow correct command, address, and data-access controls, the GPMC_CONFIG1_i register associated with a NAND device region must be initialized in asynchronous read and write modes with the parameters listed in [Table 13-166](#). Failure to comply with these settings corrupts the NAND interface protocol.

Table 13-166. Chip-Select Configuration for NAND Interfacing

Bit Field	Register	Value	Comments
WRAPBURST	GPMC_CONFIG1_i[31] ⁽¹⁾	0	No wrap
READMULTIPLE	GPMC_CONFIG1_i[30]	0	Single access
READTYPE	GPMC_CONFIG1_i[29]	0	Asynchronous mode
WRITEMULTIPLE	GPMC_CONFIG1_i[28]	0	Single access
WRITETYPE	GPMC_CONFIG1_i[27]	0	Asynchronous mode
CLKACTIVATIONTIME	GPMC_CONFIG1_i[26-25]	0b00	
ATTACHEDDEVICEPAGELENGTH	GPMC_CONFIG1_i[24-23]	Don't care	Single-access mode
WAITREADMONITORING	GPMC_CONFIG1_i[22]	0	Wait not monitored by GPMC access engine
WAITWRITEMONITORING	GPMC_CONFIG1_i[21]	0	Wait not monitored by GPMC access engine
WAITMONITORINGTIME	GPMC_CONFIG1_i[19-18]	Don't care	Wait not monitored by GPMC access engine
WAITPINSELECT	GPMC_CONFIG1_i[17-16]		Select which wait is monitored by edge detectors
DEVICESTYPE	GPMC_CONFIG1_i[13-12]	0b00 or 0b01	8- or 16-bit interface
DEVICETYPE	GPMC_CONFIG1_i[11-10]	0b10	NAND device in stream mode
MUXADDDATA	GPMC_CONFIG1_i[9-8]	0b00	non-multiplexed mode
TIMEPARAGRANULARITY	GPMC_CONFIG1_i[4]	0	Timing achieved with best GPMC clock granularity

Table 13-166. Chip-Select Configuration for NAND Interfacing (continued)

Bit Field	Register	Value	Comments
GPMCCLKDIVIDER	GPMC_CONFIG1_[1-0]	Don't care	Asynchronous mode

(1) $i = 0$ to 3

The GPMC_CONFIG1_i to GPMC_CONFIG4_i registers (where $i = 0$ to 3) associated with a NAND device region must be initialized with the correct control-signal timing value according to the NAND device timing parameters.

13.3.1.4.11.2 NAND Device Command and Address Phase Control

NAND devices require multiple address programming phases. The software driver must issue the correct number of command and address program accesses, according to the device command set and the device address-mapping scheme.

NAND device-command and address-phase programming is achieved through write requests to the GPMC_NAND_COMMAND_i and GPMC_NAND_ADDRESS_i register locations (where $i = 0$ to 3) with the correct command and address values. These locations are mapped in the associated chip-select register region. The associated chip-select signal timing control must be programmed according to the NAND device timing specification.

Command and address values are not latched during the access and cannot be read back at the register location.

- Only write accesses must be issued to these locations, but the GPMC does not discard any read access. Accessing a NAND device with nOE and CLE or ALE asserted (read access) can produce undefined results.
- Write accesses to the GPMC_NAND_COMMAND_i and GPMC_NAND_ADDRESS_i register locations must be posted for faster operations (where $i = 0$ to 3). The GPMC_CONFIG[0] NANDFORCEPOSTEDWRITE bit enables write accesses to these locations as posted, even if they are defined as nonposted.

A write buffer is used to store write transaction information before the external device is accessed:

- Up to eight consecutive posted write accesses can be accepted and stored in the write buffer.
- For nonposted write, the pipeline is one deep.
- An GPMC_STATUS[0] EMPTYWRITEBUFFERSTATUS bit stores the empty status of the write buffer.

The GPMC_NAND_COMMAND_i and GPMC_NAND_ADDRESS_i registers (where $i = 0$ to 3) are 32-bit word locations, which means any 32- or 16-bit word access is split into 4- or 2-byte accesses if an 8-bit-wide NAND device is attached. For multiple-command phase or multiple-address phase, the software driver can use 32- or 16-bit word access to these registers, but it must consider the splitting and little-endian ordering scheme. When only one byte command or address phase is required, only byte write access to the GPMC_NAND_COMMAND_i and GPMC_NAND_ADDRESS_i registers can be used, and any of the four byte locations of the registers is valid.

The same applies to a GPMC_NAND_COMMAND_i and a GPMC_NAND_ADDRESS_i (where $i = 0$ to 3) 32-bit word write access to a 16-bit-wide NAND device (split into two 16-bit word accesses). In the case of a 16-bit word write access, the MSByte of the 16-bit word value must be set according to the NAND device requirement (usually 0). Either 16-bit word location or any one of the four byte locations of the registers is valid.

13.3.1.4.11.3 Command Latch Cycle

Writing data at the GPMC_NAND_COMMAND_i location (where $i = 0$ to 3) places the data as the NAND command value on the bus, using a regular asynchronous write access.

- nCE is controlled by the CSONTIME and CSWROFFTIME timing parameters.
- CLE is controlled by the ADVONTIME and ADVWROFFTIME timing parameters.
- nWE is controlled by the WEONTIME and WEOFFTIME timing parameters.
- ALE and nRE (nOE) are maintained inactive.

Figure 13-153 shows the NAND command latch cycle.

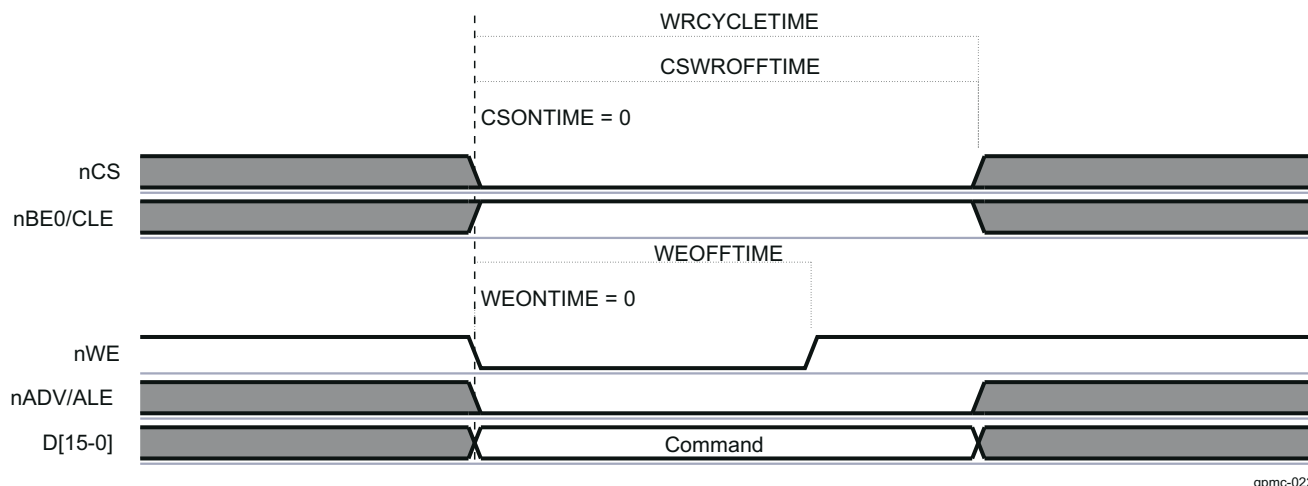
Figure 13-153. NAND Command Latch Cycle
Note

CLE is shared with the nBE0 output signal and has an inverted polarity from BE0. The NAND qualifier deals with this. During the asynchronous NAND data access cycle, nBE0 (also nBE1) must not toggle, because it is shared with CLE.

NAND flash memories do not use byte-enable signals.

13.3.1.4.11.1.4 Address Latch Cycle

Writing data at the GPMC_NAND_ADDRESS_i location (where i = 0 to 3) places the data as the NAND partial address value on the bus, using a regular asynchronous write access.

- nCS is controlled by the CSONTIME and CSWROFFTIME timing parameters.
- ALE is controlled by the ADVONTIME and ADVWROFFTIME timing parameters.
- nWE is controlled by the WEONTIME and WEOFFTIME timing parameters.
- CLE and nRE (nOE) are maintained inactive.

Figure 13-154 shows the NAND address latch cycle.

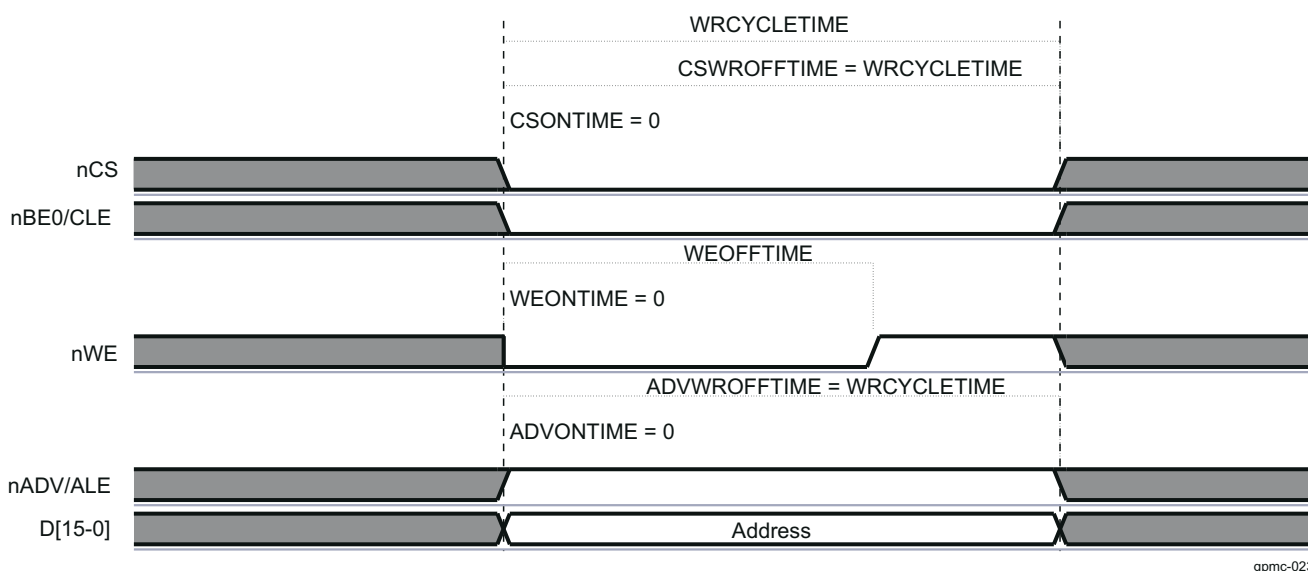
Figure 13-154. NAND Address Latch Cycle

Note

ALE is shared with the nADV output signal and has an inverted polarity from ADV. The NAND qualifier deals with this. During the asynchronous NAND data access cycle, ALE is kept stable.

13.3.1.4.11.1.5 NAND Device Data Read and Write Phase Control in Stream Mode

NAND device data read and write accesses are achieved through a read or write request to the chip-select-associated memory region at any address location in the region or through a read or write request to the GPMC_NAND_DATA_i location (where i = 0 to 3) mapped in the chip-select-associated control register region. GPMC_NAND_DATA_i is not a true register, but an address location to enable nRE or nWE signal control. The associated chip-select signal timing control must be programmed according to the NAND device timing specification.

Reading data from the GPMC_NAND_DATA_i location or from any location in the associated chip-select memory region activates an asynchronous read access.

- nCS is controlled by the CSONTIME and CSRDOFFTIME timing parameters.
- nRE is controlled by the OEONTIME and OEOFFTIME timing parameters.
- To take advantage of nRE high-to-data invalid minimum timing value, RDACCESSTIME can be set so that data are effectively captured after nRE deassertion. This allows optimization of NAND read access cycle time completion. For optimal timing parameter settings, see the NAND device and the device timing parameters.

ALE, CLE, and nWE are maintained inactive.

Figure 13-155 shows the NAND data read cycle.

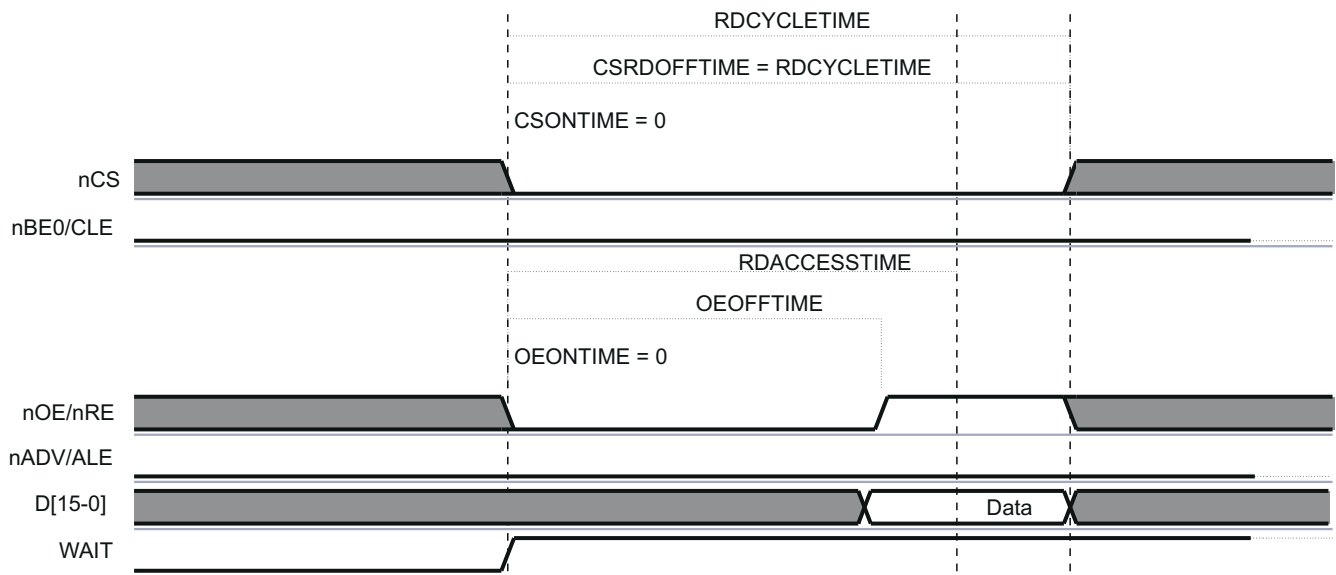

gpmc-024

Figure 13-155. NAND Data Read Cycle

Writing data to the GPMC_NAND_DATA_i location or to any location in the associated chip-select memory region activates an asynchronous write access.

- nCS is controlled by the CSONTIME and CSWROFFTIME timing parameters.
- nWE is controlled by the WEONTIME and WEOFFTIME timing parameters.
- ALE, CLE, and nRE (nOE) are maintained inactive.

Figure 13-156 shows the NAND data write cycle.

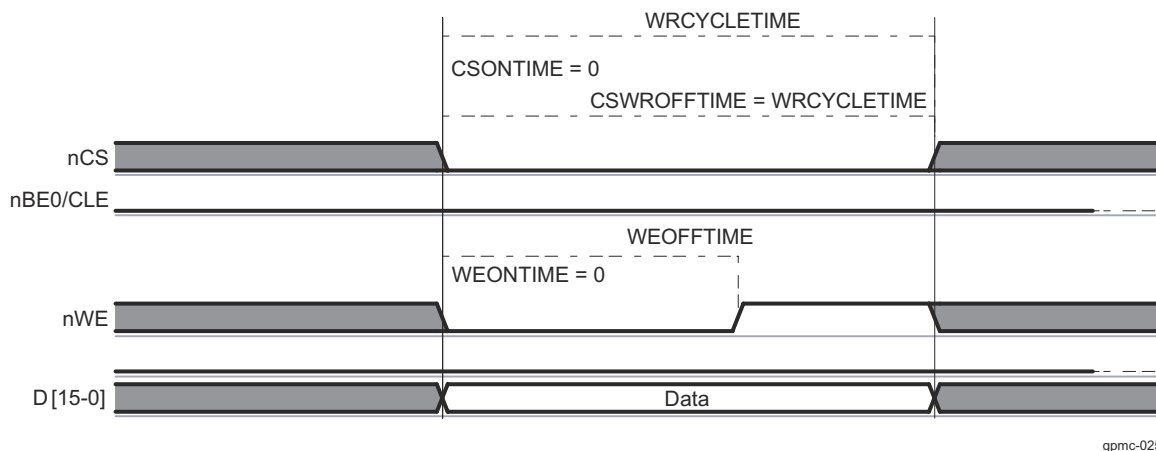
Figure 13-156. NAND Data Write Cycle

13.3.1.4.11.1.6 NAND Device General Chip-Select Timing Control Requirement

For most NAND devices, read data access time is dominated by nCS-to-data-valid timing and has faster nRE-to-data-valid timing. Successive accesses with nCS deassertions between accesses are affected by this timing constraint. Because accesses to a NAND device can be interleaved with other chip-select accesses, there is no certainty that nCS always stays low between two accesses to the same chip-select. Moreover, an nCS deassertion time between the same chip-select NAND accesses is likely to be required as follows: the nCS deassertion requires programming CYCLETIME and RDACCESSTIME according to the nCS-to-data-valid critical timing.

To get full performance from NAND read and write accesses, the prefetch engine can dynamically reduce the following on back-to-back NAND accesses (to the same memory) and suppress the minimum nCS high pulse width between accesses:

- RDCYCLETIME
- WRCYCLETIME
- RDACCESSTIME
- WRACCESSTIME
- CSRDOFFTIME
- CSWROFFTIME
- ADVRDOFFTIME
- ADVWROFFTIME
- OEOFFTIME
- WEOFFTIME

For more information about optimal prefetch engine access, see [Section 13.3.1.4.11.4, Prefetch and Write-Posting Engine](#).

Some NAND devices require minimum write-to-read idle time, especially for device-status read accesses following status-read command programming (write access). If such write-to-read transactions are used, a minimum nCS high pulse width must be set. For this, CYCLE2CYCLESAMECSEN and CYCLE2CYCLEDELAY must be set according to the appropriate timing requirement to prevent any timing violation.

NAND devices usually have an important nRE high-to-data bus in three-state mode. This requires a bus turnaround setting (BUSTURNAROUND = 1) so that the next access to a different chip-select is delayed until the BUSTURNAROUND delay completes. Back-to-back NAND read accesses to the same NAND flash are not affected by the programmed bus turnaround delay.

13.3.1.4.11.1.7 Read and Write Access Size Adaptation

13.3.1.4.11.1.7.1 8-Bit-Wide NAND Device

Host 16- and 32-bit word read and write access requests to a chip-select associated with an 8-bit-wide NAND device are split into successive read and write byte accesses to the NAND memory device. Byte access is ordered according to little-endian organization. A NAND 8-bit-wide device must be interfaced on the D0D7 interface bus lane. GPMC data accesses are justified on this bus lane when the cs is associated with an 8-bit-wide NAND device.

13.3.1.4.11.1.7.2 16-Bit-Wide NAND Device

Host 32-bit word read and write access requests to a chip-select associated with a 16-bit-wide NAND device are split into successive read and write 16-bit word accesses to the NAND memory device. 16-bit word access is ordered according to little-endian organization.

Host byte read and write access requests to a 16-bit-wide NAND device are completed as 16-bit accesses on the device itself, because there is no byte-addressing capability on 16-bit-wide NAND devices. This means that the NAND device address pointer is incremented on a 16-bit word basis and not on a byte basis. For a read access, only the requested byte is given back to the host, but the remaining byte is not stored or saved by the GPMC, and the next byte or 16-bit word read access gets the next 16-bit word NAND location. For a write access, the invalid byte part of the 16-bit word is driven to FF, and the next byte or 16-bit word write access programs the next 16-bit word NAND location.

Generally, byte access to a 16-bit-wide NAND device must be avoided, especially when ECC calculation is enabled. 8- or 16-bit ECC-based computations are corrupted by a byte read to a 16-bit-wide NAND device, because the nonrequested byte is considered invalid on a read access (not captured on the external data bus; FF is fed to the ECC engine) and is set to FF on a write access.

Host requests (read/write) issued in the chip-select memory region are translated in successive single or split accesses (read/write) to the attached device. Therefore, incrementing 32-bit burst requests are translated in multiple 32-bit sequential accesses following the access adaptation of the 32-bit to 8- or 16-bit device.

13.3.1.4.11.2 NAND Device-Ready Pin

The NAND memory device provides a ready pin to indicate data availability after a block/page opening and to indicate that data programming is complete. The ready pin can be connected to one of the wait GPMC input pins; data read accesses must not be tried when the ready pin is sampled inactive (device is not ready) even if the associated chip-select WAITREADMINITORING bit field is set. The duration of the NAND device busy state after the block/page opening is so long (up to 50 micro second) that accesses occurring when the ready pin is sampled inactive can stall GPMC access and eventually cause a system time-out.

Note

If a read access to a NAND flash is done using WAIT monitoring mode, the device is blocked during a page opening, and so is the GPMC. If the correct settings are used, other chip-selects can be used while the memory processes the page opening command.

To avoid a time-out caused by a block/page opening delay in NAND flash, disable the WAIT pin monitoring for read and write accesses (that is, set the GPMC_CONFIG1_i[21] WAITWRITEMONITORING and GPMC_CONFIG1_i[22] WAITREADMONITORING bits to 0, where $i = 0$ to 3), and use one of the following methods instead:

- Use software to poll the WAITxSTATUS bit (where $x = 0$ to 1) of the GPMC_STATUS.
- Configure an interrupt that is generated on the WAIT signal change (through the GPMC_IRQENABLE register bits[11-8]).

Even if the READWAITMONITORING bit is not set, the external memory nR/B pin status is captured in the programmed wait bit in the GPMC_STATUS register.

The READWAITMONITORING bit method must be used for other memories than NAND flash, if they require the use of a WAIT signal.

13.3.1.4.11.2.1 Ready Pin Monitored by Software Polling

The ready signal state can be monitored through the GPMC_STATUS[9-8] WAITxSTATUS bit (where $x = 0$ to 1). Software must monitor the ready pin only when the signal is declared valid. Refer to the NAND device timing parameters to set the correct software temporization to monitor ready only after the invalid window is complete from the last read command written to the NAND device.

13.3.1.4.11.2.2 Ready Pin Monitored by Hardware Interrupt

Each GPMC_WAIT input pin can generate an interrupt when a wait-to-no-wait transition is detected. Depending on whether the GPMC_CONFIG[9-8] WAITxPINPOLARITY bits (where $x = 0$ to 1) is active low or active high, the wait-to-no-wait transition is a low-to-high external WAIT signal transition or a high-to-low external WAIT signal transition, respectively.

The wait transition pin detector must be cleared before any transition detection. This is done by writing 1 to the WAITxEDGEDETECTIONSTATUS bit (where $x = 0$ to 1) of the GPMC_IRQSTATUS register according to the GPMC_WAIT pin used for the NAND device-ready signal monitoring. To detect a wait-to-no-wait transition, the transition detector requires a wait active time detection of a minimum of two GPMC_FCLK cycles. Software must incorporate precautions to clear the wait transition pin detector before wait (busy) time completes.

A wait-to-no-wait transition detection can issue a GPMC interrupt if the WAITxEDGEDETECTIONENABLE bit in the GPMC_IRQENABLE register is set and if the WAITxEDGEDETECTIONSTATUS bit field in the GPMC_IRQSTATUS register is set.

The WAITMONITORINGTIME bit field does not affect wait-to-no-wait transition time detection.

It is also possible to poll the WAITxEDGEDETECTIONSTATUS bit field in the GPMC_IRQSTATUS register according to the GPMC_WAIT pin used for NAND device ready signal monitoring.

13.3.1.4.11.3 ECC Calculator

The GPMC includes an error code correction (ECC) calculator circuitry that enables ECC calculation on the fly during data read or data program (that is, write) operations. The page size supported by the ECC calculator in one calculation/context is 512 bytes.

The user can choose from two different algorithms with different error correction capabilities through the GPMC_ECC_CONFIG[16] ECCALGORITHM bit:

1. Hamming code for 1-bit error code correction on 8- or 16-bit NAND flash organized with page size greater than 512 bytes
2. Bose-Chaudhuri-Hocquenghem (BCH) code for 4- to 16-bit error correction

The GPMC does not handle the error code correction directly. During writes, the GPMC computes parity bits. During reads, the GPMC provides enough information for the processor to correct errors without reading the data buffer all over again.

The Hamming code ECC is based on a 2-dimensional (2D) (row and column) bit parity accumulation. This parity accumulation is accomplished on the programmed number of bytes or 16-bit words read from the memory device, or is written to the memory device in stream mode.

Because the ECC engine includes only one accumulation context, it can be allocated to only one chip-select at a time through the GPMC_ECC_CONFIG[3-1] ECCCS bit field. Even if two chip-selects use different ECC algorithms, one the Hamming code and the other a BCH code, they must define separate ECC contexts because some of the ECC registers are common to all types of algorithms.

13.3.1.4.11.3.1 Hamming Code

All references to ECC in this subsection refer to the 1-bit error correction Hamming code.

The ECC is based on a 2D (row and column) bit parity accumulation known as the Hamming code. The parity accumulation is done for a programmed number of bytes or 16-bit word read from the memory device or written to the memory device in stream mode.

There is no automatic error detection or correction, and the software NAND driver must read the multiple ECC calculation results, compare them to the expected code value, and take the appropriate corrective actions according to the error handling strategy (ECC storage in spare byte, error correction on read, block invalidation).

The ECC engine includes a single accumulation context. It can be allocated to a single designated chip-select at a time, and parallel computations on different chip-selects are not possible. Because it is allocated to a single chip-select, the ECC computation is not affected by interleaved GPMC accesses to other chip-selects and devices. The ECC accumulation is sequentially processed in the order of data read from or written to the memory on the designated chip-select. The ECC engine does not differentiate read accesses from write accesses and does not differentiate data from command or status information. Software must ensure that only relevant data are passed to the NAND flash memory while the ECC computation engine is active.

The starting NAND page location must be programmed first, followed by an ECC accumulation context reset with an ECC enabling, if required. The NAND device accesses discussed in the following sections must be limited to data read or write until the specified number of ECC calculations is complete.

13.3.1.4.11.3.1.1 ECC Result Register and ECC Computation Accumulation Size

The GPMC includes up to nine ECC result registers (GPMC_ECCj_RESULT, where j = 1 to 9) to store ECC computation results when the specified number of bytes or 16-bit words has been computed.

The ECC result registers are used sequentially: one ECC result is stored in one ECC result register on the list, the next ECC result is stored in the next ECC result register on the list, and so forth, until the last ECC computation. The value of the GPMC_ECCj_RESULT register is valid only when the programmed number of bytes or 16-bit words has been accumulated, which means that the same number of bytes or 16-bit words has been read from or written to the NAND device in sequence.

The GPMC_ECC_CONTROL[3-0] ECCPOINTER bit field must be set to the correct value to select the ECC result register to be used first in the list for the incoming ECC computation process. The ECCPointer can be read to determine which ECC register is used in the next ECC result storage for the ongoing ECC computation. The value of the GPMC_ECCj_RESULT register (where j = 1 to 9) can be considered valid when ECCPOINTER equals j + 1. When the GPMC_ECCj_RESULT register (where j = 9) is updated, ECCPOINTER is frozen at 10, and ECC computing is stopped (ECCENABLE = 0).

The ECC accumulator must be reset before any ECC computation accumulation process. The GPMC_ECC_CONTROL[8] ECCCLEAR bit must be set to 1 (nonpersistent bit) to clear the accumulator and all ECC result registers.

For each ECC result (each GPMC_ECCj_RESULT register, where j = 1 to 9), the number of bytes or 16-bit words used for ECC computing accumulation can be selected from between two programmable values.

The ECC_jRESULTS_{SIZE} bits (where j = 1 to 9) in the GPMC_ECC_SIZE_CONFIG register select which programmable size value (ECCSIZE0 or ECCSIZE1) must be used for this ECC result (stored in the GPMC_ECC_j_RESULT register).

The ECCSIZE0 and ECCSIZE1 bit fields allow selection of the number of bytes or 16-bit words used for ECC computation accumulation. Any even values from 2 to 512 are allowed.

Flexibility in the number of ECCs computed and the number of bytes or 16-bit words used in the successive ECC computations enables different NAND page error-correction strategies. Usually based on 256 or 512 bytes and on 128 or 256 16-bit word, the number of ECC results required is a function of the NAND device page size. Specific ECC accumulation size can be used when computing the ECC on the NAND spare byte.

For example, with a 2-KB data page, 8-bit-wide NAND device, eight ECCs accumulated on 256 bytes can be computed and added to one extra ECC computed on the 24 spare bytes area where the eight ECC results used for comparison and correction with the computed data page ECC are stored. The GPMC then provides nine GPMC_ECC_j_RESULT registers (j = 1 to 9) to store the results. In this case, ECCSIZE0 is set to 256, and ECCSIZE1 is set to 24; the ECC[1-8]RESULTS_{SIZE} bits are set to 0, and the ECC9RESULTS_{SIZE} bit is set to 1.

13.3.1.4.11.3.1.2 ECC Enabling

The GPMC_ECC_CONFIG[3-1] ECCCS bit field selects the allocated chip-select. The GPMC_ECC_CONFIG[0] ECCENABLE bit enables ECC computation on the next detected read or write access to the selected chip-select.

The following fields must not be changed or cleared while an ECC computation is in progress:

- CCPOINTER
- ECCCLEAR
- ECCSIZE
- ECC_jRESULTS_{SIZE} (where j = 1 to 9)
- ECC16B
- ECCCS

The ECC accumulator and ECC result register must not be changed or cleared while an ECC computation is in progress.

Table 13-167 describes the ECC enable settings.

Table 13-167. ECC Enable Settings

Bit Field	Register	Value	Comments
ECCCS	GPMC_ECC_CONFIG	0–3	Selects the chip-select where ECC is computed
ECC16B	GPMC_ECC_CONFIG	0/1	Selects column number for ECC calculation
ECCCLEAR	GPMC_ECC_CONTROL	0–7	Clears all ECC result registers
ECCPOINTER	GPMC_ECC_CONTROL	0–7	A write to this bit field selects the ECC result register where the first ECC computation is stored. Set to 1 by default.
ECCSIZE1	GPMC_ECC_SIZE_CONFIG	0x00–0xFF	Defines ECCSIZE1
ECCSIZE0	GPMC_ECC_SIZE_CONFIG	0x00–0xFF	Defines ECCSIZE0
ECC _j RESULTS _{SIZE} (j from 1 to 9)	GPMC_ECC_SIZE_CONFIG	0/1	Selects the size of ECC _n result register
ECCENABLE	GPMC_ECC_CONFIG	1	Enables the ECC computation

13.3.1.4.11.3.1.3 ECC Computation

The ECC algorithm is a multiple parity bit accumulation computed on the odd and even bit streams extracted from the byte or Word16 streams. The parity accumulation is split into row and column accumulations, as shown in Figure 13-157 and Figure 13-158. The intermediate row and column parities are used to compute the upper level row and column parities. Only the final computation of each parity bit is used for ECC comparison and correction.

P1o = bit7 XOR bit5 XOR bit3 XOR bit1 on each byte of the data stream

P1e = bit6 XOR bit4 XOR bit2 XOR bit0 on each byte of the data stream

P2o = bit7 XOR bit6 XOR bit3 XOR bit2 on each byte of the data stream

P2e = bit5 XOR bit4 XOR bit1 XOR bit0 on each byte of the data stream

P4o = bit7 XOR bit6 XOR bit5 XOR bit4 on each byte of the data stream

P4e = bit3 XOR bit2 XOR bit1 XOR bit0 on each byte of the data stream

Each column parity bit is XORed with the previous accumulated value.

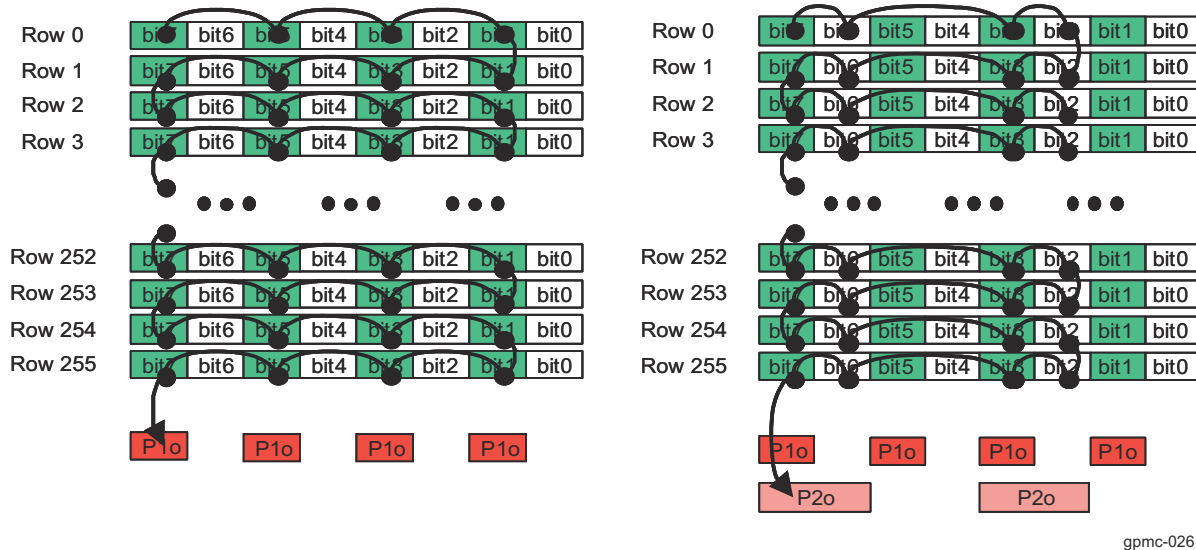

Figure 13-157. Hamming Code Accumulation Algorithm (1/2)

For line parities, the bits of each new data are XORed together, and line parity bits are computed as described below:

P8e = row0 XOR row2 XOR row4 XOR ... XOR row254

P8o = row1 XOR row3 XOR row5 XOR ... XOR row255

P16e = row0 XOR row1 XOR row4 XOR row5 XOR ... XOR row252 XOR row 253

P16o = row2 XOR row3 XOR row6 XOR row7 XOR ... XOR row254 XOR row 255

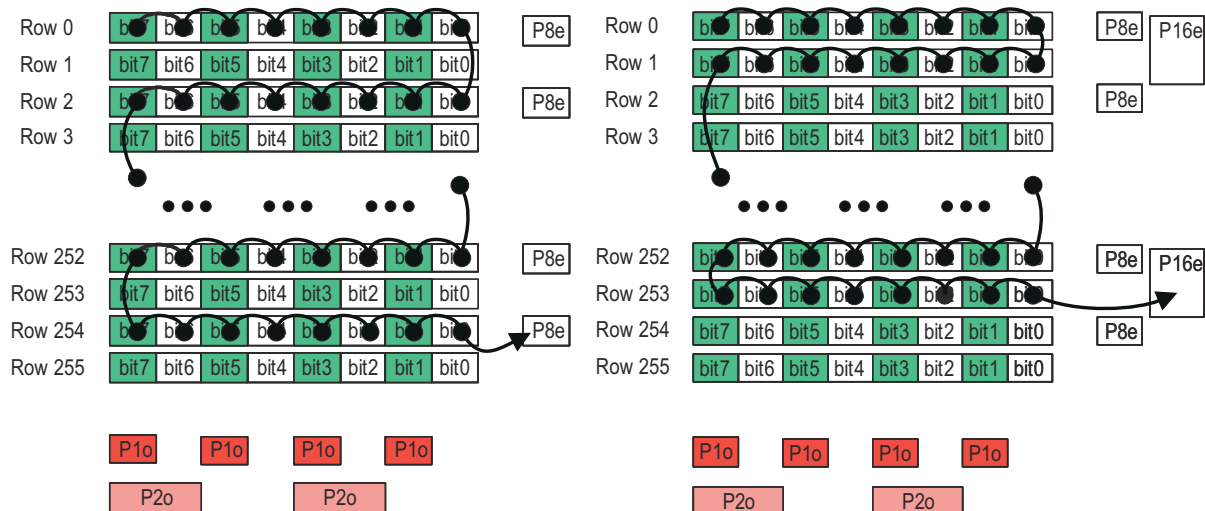

gpmc-027

Figure 13-158. Hamming Code Accumulation Algorithm (2/2)

Unused parity bits in the result registers are set to 0.

Figure 13-159 shows ECC computation for a 256-byte data stream (read or write). The result includes six column parity bits (P1o-P2o-P4o for odd parities, and P1e-P2e-P4e for even parities) and sixteen row parity bits (P8o-P16o-P32o--P1024o for odd parities, and P8e-P16e-P32e--P1024e for even parities).

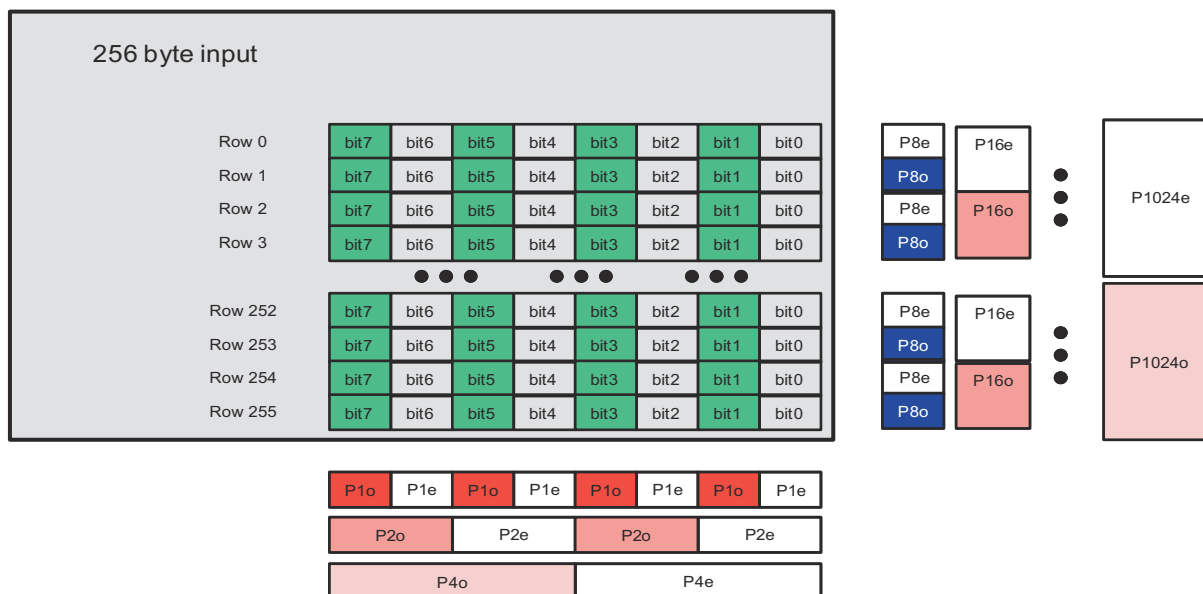

gpmc-028

Figure 13-159. ECC Computation for a 256-Byte Data Stream (Read or Write)

Figure 13-160 shows ECC computation for a 512-byte data stream (read or write). The result includes six column parity bits (P1o-P2o-P4o for odd parities, and P1e-P2e-P4e for even parities) and eighteen row parity bits (P8o-P16o-P32o--P1024o - P2048o for odd parities, and P8e-P16e-P32e--P1024e- P2048e for even parities).

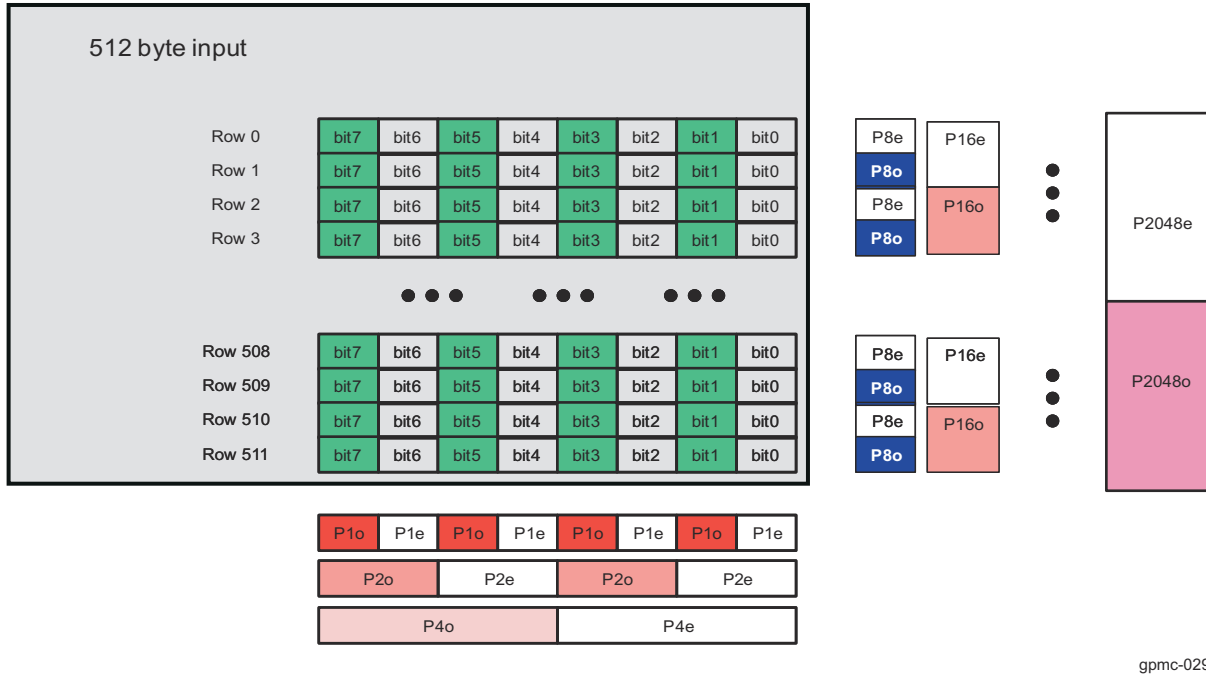

Figure 13-160. ECC Computation for a 512-Byte Data Stream (Read or Write)

gpmc-029

For a 2-KB page, four 512 bytes ECC calculations plus 1 for the spare area are required. Results are stored in the GPMC_ECCj_RESULT registers (where j = 1 to 9).

13.3.1.4.11.3.1.4 ECC Comparison and Correction

To detect an error, the computed ECC result must be XORed with the parity value stored in the spare area of the accessed page.

- If the result of this logical XOR is all 0s, no error is detected and the read data is correct.
- If every second bit in the parity result is a 1, 1 bit is corrupted and is located at bit address (P2048o, P1024o, P512o, P256o, P128o, P64o, P32o, P16o, P8o, P4o, P2o, P1o). Software must correct the corresponding bit.
- If only 1 bit in the parity result is 1, it is an ECC error and the read data is correct.

13.3.1.4.11.3.1.5 ECC Calculation Based on 8-Bit Word

The 8-bit-based ECC computation is used for 8-bit-wide NAND device interfacing.

The 8-bit-based ECC computation can be used for 16-bit-wide NAND device interfacing to get backward compatibility on the error-handling strategy used with 8-bit-wide NAND devices. In this case, the 16-bit-wide data read from or written to the NAND device is fragmented into 2 bytes. According to little-endian access, the LSB of the 16-bit-wide data is ordered first in the byte stream used for 8-bit-based ECC computation.

13.3.1.4.11.3.1.6 ECC Calculation Based on 16-Bit Word

ECC computation based on an 16-bit word is used for 16-bit-wide NAND device interfacing. This ECC computation is not supported when interfacing an 8-bit-wide NAND device, and the GPMC_ECC_CONFIG[7] ECC16B bit must be set to 0 when interfacing an 8-bit-wide NAND device.

The parity computation based on 16-bit words affects the row and column parity mapping. The main difference is that the odd and even parity bits P8o and P8e are computed on rows for an 8-bit-based ECC and on columns for a 16-bit based ECC. Figure 13-161 and Figure 13-162 show a 128 Word16 ECC computation scheme and a 256 16-bit word ECC computation scheme.

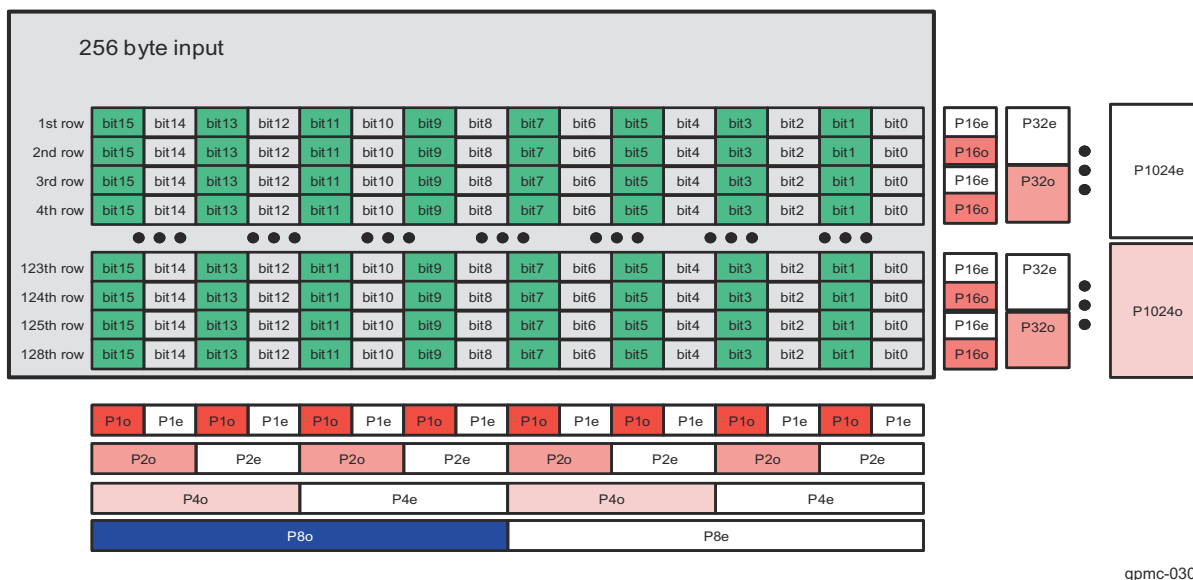

Figure 13-161. 128 Word16 ECC Computation

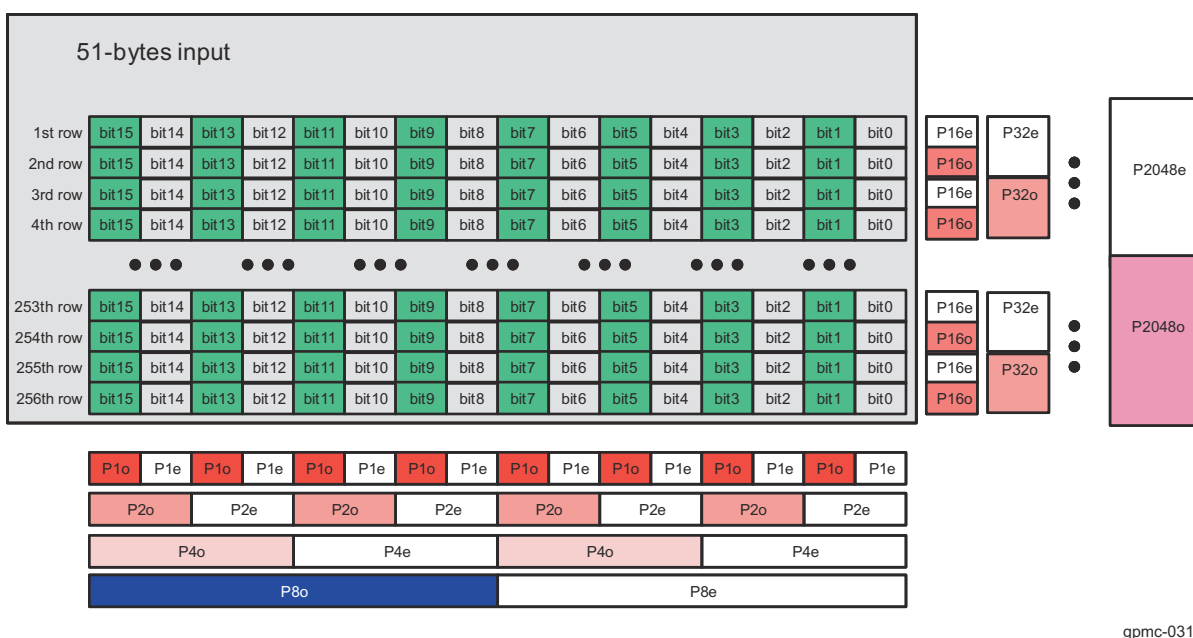

Figure 13-162. 256 Word16 ECC Computation

13.3.1.4.11.3.2 BCH Code

All references to ECC in this subsection refer to the 4- to 16-bit error correction BCH code.

13.3.1.4.11.3.2.1 Requirements

1. Read and write accesses to a NAND flash take place by whole pages, in a predetermined sequence: first the data byte page itself, and then some spare bytes, including the BCH ECC (and other information). The NAND device can cache a full page, including spares, for read and write accesses.
 - Typical page write sequence:
 - Sequential write to NAND cache of main data plus spare data, for a page. ECC is calculated on the fly. Calculated ECC can be inserted on the fly in the spares or replaced by dummy accesses.

- When the calculated ECC is replaced by dummy accesses, it must be written to the cache in a second, separate phase. The ECC module is disabled during that time.
- NAND writes its cache line (page) to the array.
- Typical page read sequence:
 - Sequential read of a page. ECC is calculated on the fly.
 - The status of the ECC module buffers determines the presence of errors.
- 2. Accesses to several memories can be interleaved by the GPMC, but only one of those memories at a time can be a NAND using the BCH engine; in other words, only one BCH calculation (for example, for a single page) can be ongoing at any time. The sequential nature of NAND accesses ensures that the data is always written or read out in the same order. BCH-relevant accesses are selected by the chip-selects of the GPMC.
- 3. Each page can hold up to 4KB of data, spare bytes not included. This means up to 8×512 -byte BCH messages. Because all the data is written or read out first, followed by the BCH ECC, the BCH engine must be able to hold eight 104-bit remainders or syndromes (or smaller, 52-bit ones) at the same time.

The BCH module can store all remainders internally. After the page start, an internal counter is used to detect the 512-byte sector boundaries. On those boundaries, the current remainder is stored and the divider reset for the next calculation. At the end of the page, the BCH module contains all remainders.

- 4. NAND access cycles hold 8 or 16 bits of data each (1 or 2 bytes); Each NAND cycle takes at least four cycles of the GPMC internal clock. This means the NAND flash timing parameters must define a RDCYCLETIME and a WRCYCLETIME of at least four clock cycles after optimization when using the BCH calculator.
- 5. The spare area is assumed to be large enough to hold the BCH ECC; that is, to have a message of at least 13 bytes available per 512-byte sector of data. The zone of unused spare area by the ECC may or may not be protected by the same ECC scheme, by extending the BCH message beyond 512 bytes (the maximum codeword is 1023 bytes long, ECC included, which leaves much space to cover spare bytes).

13.3.1.4.11.3.2.2 Memory Mapping of BCH Codeword

BCH encoding considers a block of data to protect as a polynomial message $M(x)$. In a standard case, 512 bytes of data (that is, 2^{12} bits = 4096 bits) are seen as a polynomial of degree $2^{12} - 1 = 4095$, with parameters ranging from M_0 to M_{4095} . For 512 bytes of data, 52 bits are required for 4-bit error correction, 104 bits are required for 8-bit error correction, and 207 bits are required for 16-bit error correction. The ECC is a remainder polynomial $R(x)$ of degree 103 (or 51, depending on the selected mode). The complete codeword $C(x)$ is the concatenation of $M(x)$ and $R(x)$, as described in [Table 13-168](#).

Table 13-168. Flattened BCH Codeword Mapping (512 Bytes + 104 Bits)

Bit Number	Message $M(x)$			ECC $R(x)$		
	M_{4095}	...	M_0	R_{103}	...	R_0

If the message is extended by the addition of spare bytes to be protected by the same ECC, the principle is still valid. For example, a 3-byte extension of the message gives a polynomial message $M(x)$ of degree $((512 + 3) \times 8) - 1 = 4119$, for a total of $3 + 13 = 16$ spare bytes of spare, all protected as part of the same codeword.

The message and the ECC bits are manipulated and mapped in the GPMC byte-oriented system. The ECC bits are stored in the following registers (where $i = 0$ to 3):

- GPMC_BCH_RESULT0_i
- GPMC_BCH_RESULT1_i
- GPMC_BCH_RESULT2_i
- GPMC_BCH_RESULT3_i

3.1.4.11.3.2.2.1 Memory Mapping of Data Message

The data message mapping must follow the following rules:

- Bit endianness within a byte is little-endian; that is, the bytes LSB is also the lowest-degree polynomial parameter: a byte b_7 - b_0 (with b_0 the LSB) represents a segment of polynomial $b_7 * x^{(7+i)} + b_6 * x^{(6+i)} + \dots + b_0 * x^i$

- The message is mapped in the NAND starting with the highest-order parameters, that is, in the lowest addresses of a NAND page.
- Byte endianness within the 16-bit words in the NAND is big-endian (that is, the same message mapped in 8- and 16-bit memories has the same content at the same byte address).

Note

The BCH module has no visibility over actual addresses. The most important point is the sequence of data words the BCH sees. However, the NAND page is always scanned incrementally in read and write accesses, which produces the mapping patterns described in the following.

Table 13-169 and Table 13-170 describe the mapping of the same 512-byte vector (typically, a BCH message) in the NAND memory space. The byte address is only an offset module 512 (0x200), because the same page may contain several contiguous 512-byte sectors (BCH blocks). The LSB and MSB are, respectively, the bits M0 and M(2¹²–1) of the codeword mapping discussed previously. In both cases the data vectors are aligned; that is, their boundaries coincide with the RAM data word boundaries.

Table 13-169. Aligned Message Byte Mapping in 8-Bit NAND

Byte Offset	8-Bit Word
0x000	(MSB) Byte 511 (0x1FF)
0x001	Byte 510 (0x1FE)
...	...
0x1FF	Byte 0 (0x0) (LSB)

Table 13-170. Aligned Message Byte Mapping in 16-Bit NAND

Byte Offset	16-Bit Word MSB	16-Bit Word LSB
0x000	Byte 510 (0x1FE)	(MSB) Byte 511 (0x1FF)
0x002	Byte 508 (0x1FC)	Byte 509 (0x1FD)
...
0x1FE	Byte 0 (0x0)	(LSB) Byte 1 (0x1)

Table 13-171 through Table 13-176 list the mapping in memory of arbitrarily-sized messages, starting on access (byte or 16-bit word) boundaries for more clarity. Note that message may actually start and stop on arbitrary nibbles. A nibble is a 4-bit entity. The unused nibbles are not discarded, and they can still be used by the BCH module, but as part of the next message section (for example, on the ECC of another sector).

Table 13-171. Aligned Nibble Mapping of Message in 8-Bit NAND

Byte Offset	8-Bit Word	
	4-Bit Most Significant Nibble	4-Bit Least Significant Nibble
1	(MSB) Nibble S-1	Nibble S-2
2	Nibble S-3	Nibble S-4
...
S/2 – 2	Nibble 3	Nibble 2
S/2 – 1	Nibble 1	Nibble 0 (LSB)

Table 13-172. Misaligned Nibble Mapping of Message in 8-Bit NAND

Byte Offset	8-Bit Word	
	4-Bit Most Significant Nibble	4-Bit Least Significant Nibble
1	(MSB) Nibble S-1	Nibble S-2
2	Nibble S-3	Nibble S-4
...
(S + 1) / 2 – 2	Nibble 2	Nibble 1
(S + 1) / 2 – 1	Nibble 0 (LSB)	

Table 13-173. Aligned Nibble Mapping of Message in 16-Bit NAND

Byte Offset	16-Bit Word			
	4-Bit Most Significant Nibble		4-Bit Least Significant Nibble	
0	Nibble S-3	Nibble S-4	(MSB) Nibble S-1	Nibble S-2
2	Nibble S-7	Nibble S-8	Nibble S-5	Nibble S-6
...
$S/2 - 4$	Nibble 5	Nibble 4	Nibble 7	Nibble 6
$S/2 - 2$	Nibble 1	Nibble 0 (LSB)	Nibble 3	Nibble 2

Table 13-174. Misaligned Nibble Mapping of Message in 16-Bit NAND (1 Unused Nibble)

Byte Offset	16-Bit Word			
	4-Bit Most Significant Nibble		4-Bit Least Significant Nibble	
0	Nibble S-3	Nibble S-4	(MSB) Nibble S-1	Nibble S-2
2	Nibble S-7	Nibble S-8	Nibble S-5	Nibble S-6
...
$(S + 1) / 2 - 4$	Nibble 4	Nibble 3	Nibble 6	Nibble 5
$(S + 1) / 2 - 2$	Nibble 0 (LSB)		Nibble 2	Nibble 1

Table 13-175. Misaligned Nibble Mapping of Message in 16-Bit NAND (2 Unused Nibbles)

Byte Offset	16-Bit Word			
	4-Bit Most Significant Nibble		4-Bit Least Significant Nibble	
0	Nibble S-3	Nibble S-4	(MSB) Nibble S-1	Nibble S-2
2	Nibble S-7	Nibble S-8	Nibble S-5	Nibble S-6
...
$(S + 2) / 2 - 4$	Nibble 3	Nibble 2	Nibble 5	Nibble 4
$(S + 2) / 2 - 2$			Nibble 1	Nibble 0 (LSB)

Table 13-176. Misaligned Nibble Mapping of Message in 16-Bit NAND (3 Unused Nibbles)

Byte Offset	16-Bit Word			
	4-Bit Most Significant Nibble		4-Bit Least Significant Nibble	
0	Nibble S-3	Nibble S-4	(MSB) Nibble S-1	Nibble S-2
2	Nibble S-7	Nibble S-8	Nibble S-5	Nibble S-6
...
$(S + 3) / 2 - 4$	Nibble 2	Nibble 1	Nibble 4	Nibble 3
$(S + 3) / 2 - 2$			Nibble 0 (LSB)	

Many other cases exist than those given in the previous tables; for example, where the message does not start on a word boundary.

3.1.4.11.3.2.2.2 Memory-Mapping of the ECC

The ECC (or remainder) is presented by the BCH module as a single 104-bit (or 52-bit), little-endian vector. Software must fetch those 13 bytes (or 6 bytes) from the module interface and then store them to the spare area (page write) in the NAND or to an intermediate buffer for comparison with the stored ECC (page read). There are no constraints on the ECC mapping inside the spare area: it is software-controlled.

It is advised, however, to maintain a coherence in the respective formats of the message or the ECC remainder once they have been read out of the NAND. The error correction algorithm works from the complete codeword (concatenated message and remainder) once an error is detected. The creation of this codeword must be made as straightforward as possible.

There are cases in which the same NAND access contains both data and the ECC protecting that data. This is the case when the data/ECC boundary (which can be on any nibble) does not coincide with an access boundary.

The ECC is calculated on the fly following the write. In that case, the write must also contain part of the ECC because it is impossible to insert the ECC on the fly. Instead:

- During the initial page write (BCH encoding), the ECC is replaced by dummy bits. The BCH encoder is by definition turned OFF during the ECC section, so the BCH result is unmodified.
- During a second phase, the ECC is written to the correct location, next to the actual data.
- The completed line buffer is then written to the NAND array.

3.1.4.11.3.2.2.3 Wrapping Modes

For a given wrapping mode, the module automatically goes through a specific number of sections as data is being fed into the module. For each section, the BCH core can be enabled (in which case the data is fed to the BCH divider) or not (in which case the BCH simply counts to the end of the section). When enabled, the data is added to the ongoing calculation for a given sector number (for example, number 0).

Wrapping modes are described as follows. To better understand and see the real-life read and write sequences implemented with each mode, see [Section 13.3.1.4.11.3.2.3, Supported NAND Page Mappings and ECC Schemes](#).

For each mode:

- A sequence describes the mode in pseudo language, with, for each section, the size and the buffer used for ECC processing (if ON). The programmable lengths are size, size0, and size1.
- A checksum condition is given. If the checksum condition is not respected for a given mode, the module behavior is unpredictable. S is the number of sectors in the page; size0 and size1 are the section sizes programmed for the mode, in nibbles.

Wrapping modes 8 through 11 insert a 1-nibble padding where the BCH processing is OFF. This is intended for $t = 4$ ECC, where ECC is 6 bytes long and the ECC area is expected to include (at least) 1 unused nibble to remain byte-aligned.

1.4.11.3.2.2.3.1 Manual Mode (0x0)

This mode is intended for short sequences, added manually to a given buffer through the software data port input. A complete page may be built out of several such sequences.

To process an arbitrary sequence of 4-bit nibbles, accesses to the software data port, containing the appropriate data, must be made. If the sequence end does not coincide with an access boundary (for example, to process 5 nibbles = 20 bits in 16-bit access mode) and those nibbles must be skipped, a number of unused nibbles must be programmed in GPMC_ECC_SIZE_CONFIG[31-22] ECCSIZE1. In the same example, 5 nibbles to process + 3 to discard = 8 nibbles = 2×16 -bit accesses. Software must set:

- GPMC_ECC_SIZE_CONFIG[21-12] ECCSIZE0 = 0x5
- GPMC_ECC_SIZE_CONFIG[31-22] ECCSIZE1 = 0x3

Note

In the following figures, size and size0 are the same parameter.

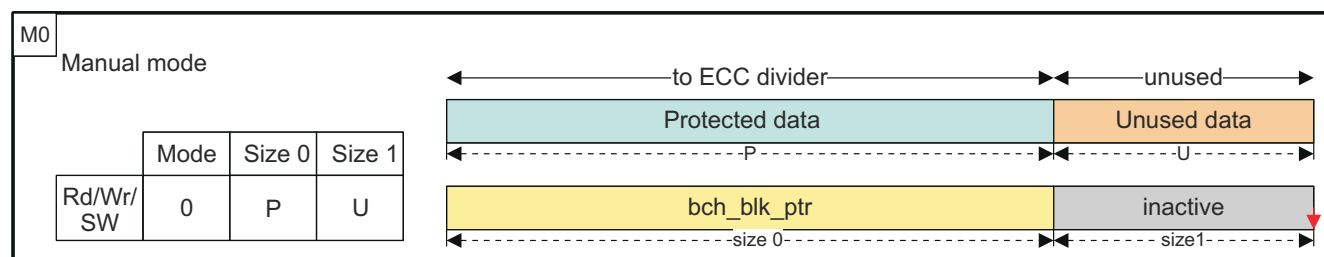

gpmc-032

Figure 13-163. Manual Mode Sequence and Mapping

Section processing sequence:

- One time with buffer
 - size0 nibbles of data, processing ON
 - size1 nibbles of unused data, processing OFF

Checksum: size0 + size1 nibbles must fit in a whole number of accesses.

In the following sections, S is the number of sectors in the page.

1.4.11.3.2.2.3.2 Mode 0x1

Page processing sequence:

- Repeat with buffer 0 to S-1
 - 512-byte data, processing ON
- Repeat with buffer 0 to S-1
 - size0 nibbles spare, processing ON
 - size1 nibbles spare, processing OFF

Checksum: Spare area size (nibbles) = $S - (size0 + size1)$

1.4.11.3.2.2.3.3 Mode 0xA (10)

Page processing sequence:

- Repeat with buffer 0 to S-1
 - 512-byte data, processing ON
- Repeat with buffer 0 to S-1
 - size0 nibbles spare, processing ON
 - 1 nibble pad spare, processing OFF
 - size1 nibbles spare, processing OFF

Checksum: Spare area size (nibbles) = $S - (size0 + 1 + size1)$

1.4.11.3.2.2.3.4 Mode 0x2

Page processing sequence:

- Repeat with buffer 0 to S-1
 - 512-byte data, processing ON
- Repeat with buffer 0 to S-1
 - size0 nibbles spare, processing OFF
 - size1 nibbles spare, processing ON

Checksum: Spare area size (nibbles) = $S - (size0 + size1)$

1.4.11.3.2.2.3.5 Mode 0x3

Page processing sequence:

- Repeat with buffer 0 to S-1
 - 512-byte data, processing ON
- One time with buffer 0
 - size0 nibbles spare, processing ON
- Repeat with buffer 0 to S-1
 - size1 nibbles spare, processing ON

Checksum: Spare area size (nibbles) = $size0 + (S - size1)$

1.4.11.3.2.2.3.6 Mode 0x7

Page processing sequence:

- Repeat with buffer 0 to S-1

- 512-byte data, processing ON
- One time with buffer 0
 - size0 nibbles spare, processing ON
- Repeat S times (no buffer used)
 - size1 nibbles spare, processing OFF

Checksum: Spare area size (nibbles) = size0 + (S – size1)

1.4.11.3.2.2.3.7 Mode 0x8

Page processing sequence:

- Repeat with buffer 0 to S-1
 - 512-byte data, processing ON
- One time with buffer 0
 - size0 nibbles spare, processing ON
- Repeat with buffer 0 to S-1
 - 1 nibble padding spare, processing OFF
 - size1 nibbles spare, processing ON

Checksum: Spare area size (nibbles) = size0 + (S – (1 + size1))

1.4.11.3.2.2.3.8 Mode 0x4

Page processing sequence:

- Repeat with buffer 0 to S-1
 - 512-byte data, processing ON
- One time (no buffer used)
 - size0 nibbles spare, processing OFF
- Repeat with buffer 0 to S-1
 - size1 nibbles spare, processing ON

Checksum: Spare area size (nibbles) = size0 + (S – size1)

1.4.11.3.2.2.3.9 Mode 0x9

Page processing sequence:

- Repeat with buffer 0 to S-1
 - 512-byte data, processing ON
- One time (no buffer used)
 - size0 nibbles spare, processing OFF
- Repeat with buffer 0 to S-1
 - 1 nibble padding spare, processing OFF
 - size1 nibbles spare, processing ON

Checksum: Spare area size (nibbles) = size0 + (S – (1 + size1))

1.4.11.3.2.2.3.10 Mode 0x5

Page processing sequence:

- Repeat with buffer 0 to S-1
 - 512-byte data, processing ON
- Repeat with buffer 0 to S-1
 - size0 nibbles spare, processing ON
- Repeat with buffer 0 to S-1
 - size1 nibbles spare, processing ON

Checksum: Spare area size (nibbles) = S – (size0 + size1)

1.4.11.3.2.2.3.11 Mode 0xB (11)

Page processing sequence:

- Repeat with buffer 0 to S-1
 - 512-byte data, processing ON
- Repeat with buffer 0 to S-1
 - size0 nibbles spare, processing ON
- Repeat with buffer 0 to S-1
 - 1 nibble padding spare, processing OFF
 - size1 nibbles spare, processing ON

Checksum: Spare area size (nibbles) = S – (size0 + 1 + size1)

1.4.11.3.2.2.3.12 Mode 0x6

Page processing sequence:

- Repeat with buffer 0 to S-1
 - 512-byte data, processing ON
- Repeat with buffer 0 to S-1
 - size0 nibbles spare, processing ON
- Repeat S times (no buffer used)
 - size1 nibbles spare, processing OFF

Checksum: Spare area size (nibbles) = S – (size0 + size1)

13.3.1.4.11.3.2.3 Supported NAND Page Mappings and ECC Schemes

The following rules apply to the entire mapping description:

- Main data area (sectors) size is hardcoded to 512 bytes.
- Spare area size is programmable.
- All page sections (of main area data bytes, protected spare bytes, unprotected spare bytes, and ECC) are defined as explained in [Section 3.1.4.11.3.2.2.1, Memory Mapping of Data Message](#).

Each of the following sections gives a NAND page mapping example (per-sector spare mappings, pooled spare mapping, per-sector spare mapping, with ECC separated at the end of the page).

In the mapping diagrams, sections that belong to the same BCH codeword have the same color (blue or green); unprotected sections are not covered (orange) by the BCH scheme.

Below each mapping diagram, a write (encoding) and read (decoding: syndrome generation) sequence is given, with the number of the active buffers at each point in time (yellow). In the inactive zones (grey), no computing is taking place but the data counter is still active.

In [Figure 13-164](#) through [Figure 13-166](#), the tables on the left summarize the mode, size0, and size1 parameters to program for, respectively, write and read processing of a page, with the given mapping, where:

- P is the size of spare byte section Protected by the ECC (in nibbles)
- U is the size of spare byte section Unprotected by the ECC (in nibbles)
- E is the size of the ECC (in nibbles)
- S is the number of Sectors per page (two in the current diagrams)

Each time the processing of a BCH block is complete (ECC calculation for write/encoding, syndrome generation for read/decoding, indicated by red arrows), the update pointer is pulsed. The processing for block 0 can be the first or the last to complete, depending on the NAND page mapping and operation (read or write). All examples show a page size of 1 KB + spares; that is, S = 2 sectors of 512 bytes. The same principles can be extended to larger pages by adding more sectors.

The actual BCH codeword size is used during the error location work to restrict the search range: by definition, errors can happen only in the codeword that was actually written to the NAND, not in the mathematical codeword of $n = 2^{13} - 1 = 8191$ bits; that codeword (higher-order bits) is all-zero and implicit during computations.

The actual BCH codeword size depends on the mode, the programmed sizes, and the sector number (all sizes in nibbles):

- Spares mapped and protected per sector (below: see M1-M2-M3-M9-M10):
 - All sectors: $(512) + P + E$
- Spares pooled and protected by sector 0 (below: see M5-M6):
 - Sector 0 codeword: $(512) + P + E$
 - Other sectors: $(512) + E$
- Unprotected spares (below: see M4-M7-M8-M11-M12):
 - All codewords $(512) + E$

3.1.4.11.3.2.3.1 Per-Sector Spare Mappings

In these schemes, each 512-byte sector of the main area has its own dedicated section of the spare area. The spare area of each sector is composed of:

- ECC, which must be located after the data it protects
- Other data, which may or may not be protected by the ECC for its sector.

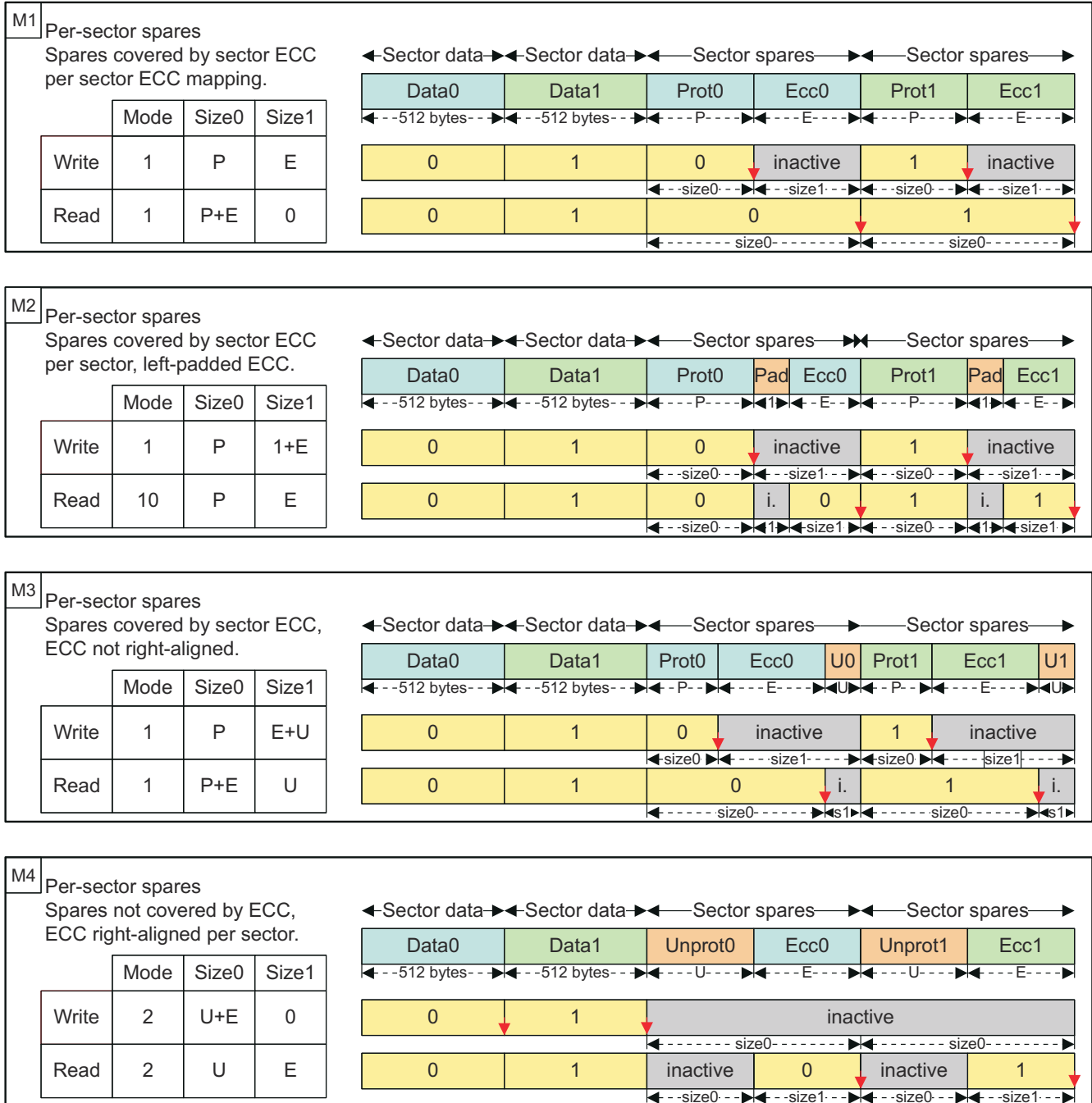

gpmc-033

Figure 13-164. NAND Page Mapping and ECC: Per-Sector Schemes

3.1.4.11.3.2.3.2 Pooled Spare Mapping

In the following schemes, the spare area is pooled for the page.

- The ECC of each sector is aligned at the end of the spare area.
- The non-ECC spare data may or may not be covered by the ECC of sector 0.

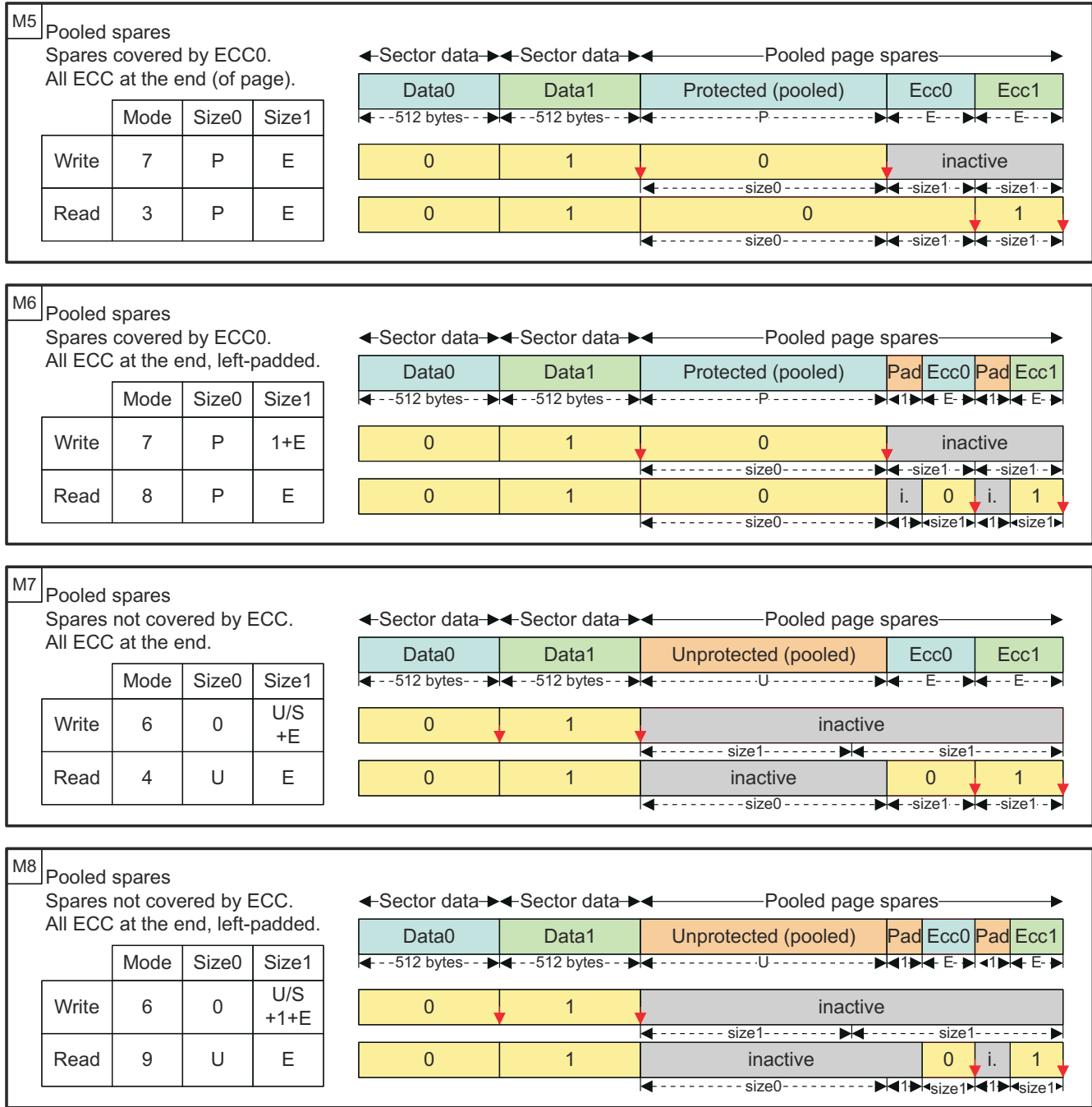

gpmc-034

Figure 13-165. NAND Page Mapping and ECC: Pooled Spare Schemes

3.1.4.11.3.2.3.3 Per-Sector Spare Mapping, with ECC Separated at the End of the Page

In these schemes, each 512-byte sector of the main area is associated with two sections of the spare area.

- ECC section, all aligned at the end of the page
- Other data section, aligned before the ECCs, each of which may or may not be protected by the ECC for its sector.

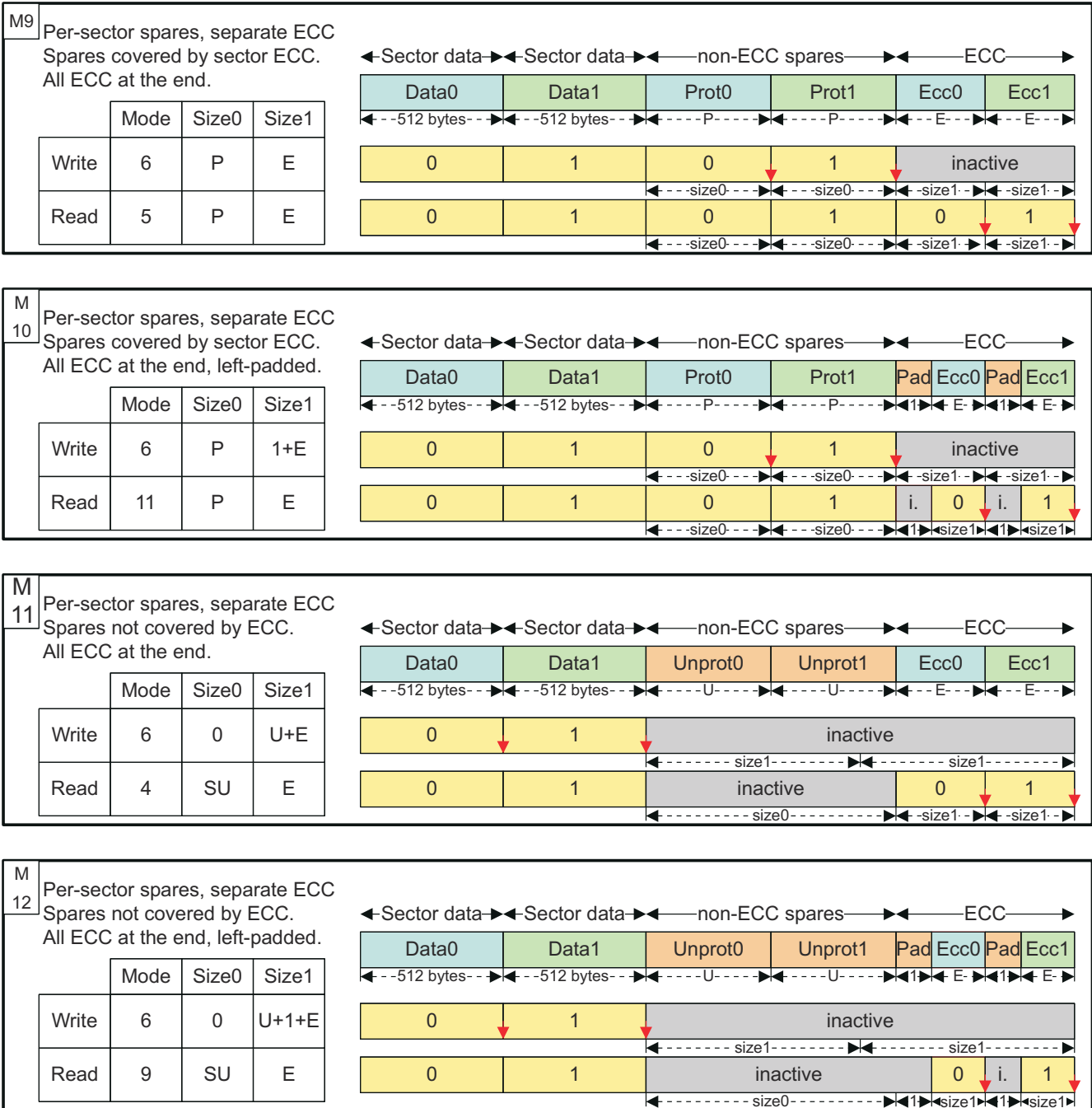

gpmc_035

Figure 13-166. NAND Page Mapping and ECC: Per-Sector Schemes, With Separate ECC

13.3.1.4.11.4 Prefetch and Write-Posting Engine

Note

Some of the GPMC features described in this section may not be supported on this family of devices. For more information, see , *GPMC Not Supported Features*.

NAND device data access cycles are usually much slower than the CPU system frequency; such NAND read or write accesses issued by the processor affect the overall system performance, especially considering long

read or write sequences required for NAND page loading or programming. To minimize this effect on system performance, the GPMC includes a prefetch and write-posting engine, which can be used to read from or write to any chip-select location in a buffered manner.

The prefetch and write-posting engine is a simplified embedded-access requester that presents requests to the access engine on a user-defined chip-select target. The access engine interleaves these requests with any request coming from the interconnect interface; as a default, the prefetch and write-posting engine has the lowest priority.

The prefetch and write-posting engine is dedicated to data-stream access (as opposed to random data access); thus, it is primarily dedicated to NAND support. The engine does not include an address generator; the request is limited to chip-select target identification. It includes a 64-byte FIFO associated with a DMA request synchronization line, for optimal DMA-based use.

The prefetch and write-posting engine uses an embedded 64-byte (32 16-bit word) FIFO to prefetch data from the NAND device in read mode (prefetch mode) or to store host data to be programmed into the NAND device in write mode (write-posting mode). The FIFO draining and filling (read and write) can be controlled by a device host processor through interrupt synchronization (an interrupt is triggered whenever a programmable threshold is reached) or by a device DMA module through DMA request synchronization, with a programmable request byte size in prefetch or posting mode.

The prefetch and write-posting engine includes a single memory pool. Therefore, only one mode, read or write, can be used at any given time. In other words, the prefetch and write-posting engine is a single-context engine that can be allocated to only one chip-select at a time for a read prefetch or a write-posting process.

The engine does not support atomic command and address phase programming and is limited to linear memory read or write access. As a consequence, it is limited to NAND data-stream access. The engine depends on the NAND software driver to control block and page opening with the correct data address pointer initialization, before the engine can read from or write to the NAND memory device.

Once started, engine data read and write sequencing is based solely on FIFO location availability and until the total programmed number of bytes is read or written.

Any host-concurrent accesses to a different chip-select are correctly interleaved with ongoing engine accesses. The engine has the lowest priority access so that host accesses to a different chip-select do not suffer a large latency.

A round-robin arbitration scheme can be enabled to ensure minimum bandwidth to the prefetch and write-posting engine in the case of back-to-back direct memory requests to a different chip-select. If the GPMC_PREFETCH_CONFIG1[23] PFPWENROUNDROBIN bit is enabled, the arbitration grants the prefetch and write-posting engine access to the GPMC bus for a number of requests programmed in the GPMC_PREFETCH_CONFIG1[19-16] PFPWWEIGHTEDPRIO bit field.

The prefetch/write-posting engine read or write request is routed to the access engine with the chip-select destination ID. After the required arbitration phase, the access engine processes the request as a single access with the data access size equal to the device size specified in the corresponding chip-select configuration.

Note

The destination chip-select configuration must be set to the NAND protocol-compatible configuration for which address lines are not used (the address bus is not changed from its current value). Selecting a different chip-select configuration can produce undefined behavior.

13.3.1.4.11.4.1 General Facts About the Engine Configuration

The engine can be configured only if the GPMC_PREFETCH_CONTROL[0] STARTENGINE bit is deasserted.

The engine must be correctly configured in prefetch or write-posting mode and must be linked to a NAND chip-select before it can be started. The chip-select is linked using the GPMC_PREFETCH_CONFIG1[26-24] ENGINECSSELECTOR bit field.

In prefetch and write-posting modes, the engine uses byte or 16-bit word access requests, respectively, for an 8- or 16-bit-wide NAND device attached to the linked chip-select. The FIFOTHRESHOLD and TRANSFERCOUNT bit fields must be programmed accordingly as a number of bytes.

When the GPMC_PREFETCH_CONFIG1[7] ENABLEENGINE bit is set, the FIFO entry on the interconnect port side is accessible at any address in the associated chip-select memory region. When the ENABLEENGINE bit is set, any host access to this chip-select is rerouted to the FIFO input. Directly accessing the NAND device linked to this chip-select from the host is still possible through the following registers (where $i = 0$ to 3):

- GPMC_NAND_COMMAND_i
- GPMC_NAND_ADDRESS_i
- GPMC_NAND_DATA_i

The FIFO entry on the interconnect port can be accessed with byte, 16-bit word, or 32-bit word access size, according to little-endian format, even though the FIFO input is 32 bits wide.

The FIFO control is made easier through the use of interrupts or DMA requests associated with the FIFOTHRESHOLD bit field. The GPMC_PREFETCH_STATUS[30-24] FIFOPOINTER bit field monitors the number of available bytes to be read in prefetch mode or the number of free empty slots that can be written in write-posting mode. The GPMC_PREFETCH_STATUS[13-0] COUNTVALUE bit field monitors the number of remaining bytes to be read or written by the engine according to the value of the TRANSFERCOUNT bit field. The FIFOPOINTER and COUNTVALUE bit fields are always expressed as a number of bytes even if a 16-bit-wide NAND device is attached to the linked chip-select.

In prefetch mode, when the FIFOPOINTER equals 0 (that is, the FIFO is empty), a host read access receives the byte last read from the FIFO as its response. In case of 32-bit word or 16-bit word read accesses, the last byte read from the FIFO is copied the required number of times to fit the requested word size. In write-posting mode, when the FIFOPOINTER equals 0 (that is, the FIFO is full), a host write overwrites the last FIFO byte location. There is no underflow or overflow error reporting in the GPMC.

13.3.1.4.11.4.2 Prefetch Mode

The prefetch mode is selected when the GPMC_PREFETCH_CONFIG1[0] ACCESSMODE bit is cleared.

The NAND software driver must issue the block and page opening (READ) command with the correct data address pointer initialization before the engine can be started to read from the NAND memory device. The engine is started by asserting the GPMC_PREFETCH_CONTROL[0] STARTENGINE bit. The STARTENGINE bit automatically clears when the prefetch process completes.

If required, the ECC calculator engine must be initialized (that is, reset, configured, and enabled) before the prefetch engine is started so that the ECC is computed correctly on all data read by the prefetch engine.

When the GPMC_PREFETCH_CONFIG1[3] SYNCHROMODE bit is cleared, the prefetch engine starts requesting data as soon as the STARTENGINE bit is set. If using this configuration, the host must monitor the NAND device-ready pin so that it sets the STARTENGINE bit only when the NAND device is in a ready state (that is, data is valid for prefetching).

When the SYNCHROMODE bit is set, the prefetch engine starts requesting data when an active-to-inactive WAIT signal transition is detected. The transition detector must be cleared before any transition detection (see [Section 13.3.1.4.11.2.2, Ready Pin Monitored by Hardware Interrupt](#)). The GPMC_PREFETCH_CONFIG1[5-4] WAITPINSELECTOR bit field selects which GPMC_WAIT pin edge detector triggers the prefetch engine in this synchronized mode.

If the STARTENGINE bit is set after the NAND address phase (page opening command), the engine is effectively started only after the actual NAND address phase completion. To prevent GPMC stall during this NAND address phase, set the STARTENGINE bit before NAND address phase completion when in synchronized mode. The prefetch engine starts when an active-to-inactive WAIT signal transition is detected. The STARTENGINE bit is automatically cleared on prefetch process completion.

The prefetch engine issues a read request to fill the FIFO with the amount of data specified by the GPMC_PREFETCH_CONFIG2[13-0] TRANSFERCOUNT bit field.

Table 13-177 describes the prefetch mode configuration.

Table 13-177. Prefetch Mode Configuration

Bit Field	Register	Value	Comments
STARTENGINE	GPMC_PREFETCH_CONTROL[0]	0	Prefetch engine can be configured only if STARTENGINE is set to 0.
ENGINECSSELECTOR	GPMC_PREFETCH_CONFIG1[26-24]	0 to 3	Selects the chip-select associated with a NAND device where the prefetch engine is active.
ACCESSMODE	GPMC_PREFETCH_CONFIG1[0]	0	Selects prefetch mode
FIFOTHRESHOLD	GPMC_PREFETCH_CONFIG1[14-8]		Selects the maximum number of bytes read or written by the host on DMA or interrupt request
TRANSFERCOUNT	GPMC_PREFETCH_CONFIG2[13-0]		Selects the number of bytes to be read or written by the engine to the selected chip-select
SYNCHROMODE	GPMC_PREFETCH_CONFIG1[3]	0/1	Selects when the engine starts the access to the chip-select
WAITPINSELECT	GPMC_PREFETCH_CONFIG1[17-16]	0 to 1	Selects WAIT pin edge detector (if GPMC_PREFETCH_CONFIG1[3] SYNCHROMODE = 0x1)
ENABLEOPTIMIZEDACCESS	GPMC_PREFETCH_CONFIG1[27]	0/1	See Section 13.3.1.4.11.4.6, Optimizing NAND Access Using the Prefetch and Write-Posting Engine .
CYCLEOPTIMIZATION	GPMC_PREFETCH_CONFIG1[30-28]		Number of clock cycle removed to timing parameters
ENABLEENGINE	GPMC_PREFETCH_CONFIG1[7]	1	Engine enabled
STARTENGINE	GPMC_PREFETCH_CONTROL[0]	1	Starts the prefetch engine

13.3.1.4.11.4.3 FIFO Control in Prefetch Mode

Note

Some of the GPMC features described in this section may not be supported on this family of devices. For more information, see , *GPMC Not Supported Features*.

The FIFO can be drained directly by a device host processor or a DMA module channel.

In draining mode, the FIFO status can be monitored through the GPMC_PREFETCH_STATUS[30-24] FIFOPointer bit field or through the GPMC_PREFETCH_STATUS[16] FIFOTHRESHOLDSTATUS bit. The FIFOPointer indicates the current number of available data to be read; FIFOTHRESHOLDSTATUS set to 1 indicates that at least FIFOTHRESHOLD bytes are available from the FIFO.

An interrupt can be triggered by the GPMC if the GPMC_IRQENABLE[0] FIFOEVENTENABLE bit is set. The FIFO interrupt event is logged, and the GPMC_IRQSTATUS[0] FIFOEVENTSTATUS bit is set. To clear the interrupt, all the available bytes must be read, or at least enough bytes to get below the programmed FIFO threshold, and the FIFOEVENTSTATUS bit must be cleared to enable further interrupt events. The FIFOEVENTSTATUS bit must always be reset before asserting the FIFOEVENTENABLE bit to clear any out-of-date logged interrupt event. This interrupt generation must be enabled after enabling the STARTENGINE bit.

Prefetch completion can be monitored through the GPMC_PREFETCH_STATUS[13-0] COUNTVALUE bit field. COUNTVALUE indicates the number of currently remaining data to be requested according to the TRANSFERCOUNT value. An interrupt can be triggered by the GPMC when the prefetch process is complete (that is, COUNTVALUE equals 0) if the GPMC_IRQENABLE[1] TERMINALCOUNTEVENTENABLE bit is set. At prefetch completion, the TERMINALCOUNT interrupt event is also logged, and the GPMC_IRQSTATUS[1] TERMINALCOUNTSTATUS bit is set. To clear the interrupt, the TERMINALCOUNTSTATUS bit must be cleared. The TERMINALCOUNTSTATUS bit must always be cleared prior to asserting the TERMINALCOUNTEVENTENABLE bit to clear any out-of-date logged interrupt event.

Note

The COUNTVALUE value is valid only when the prefetch engine is active (started), and an interrupt is only triggered when COUNTVALUE reaches 0, that is, when the prefetch engine automatically goes from an active to an inactive state.

The number of bytes to be prefetched (programmed in TRANSFERCOUNT) must be a multiple of the programmed FIFOTHRESHOLD to trigger the correct number of interrupts allowing a deterministic and transparent FIFO control. If this guideline is respected, the number of ISR accesses is always required and the FIFO is always empty after the last interrupt is triggered. In other cases, the TERMINALCOUNT interrupt must be used to read the remaining bytes in the FIFO (the number of remaining bytes being lower than the FIFOTHRESHOLD value).

In DMA draining mode, the GPMC_PREFETCH_CONFIG1[2] DMAMODE bit must be set so that the GPMC issues a DMA hardware request when at least FIFOTHRESHOLD bytes are ready to be read from the FIFO. The DMA channel that owns this DMA request must be programmed so that the number of bytes programmed in FIFOTHRESHOLD is read from the FIFO during the DMA request process. The DMA request is kept active until this number of bytes has effectively been read from the FIFO, and no other DMA request can be issued until the ongoing active request is complete.

In prefetch mode, the TERMINALCOUNT event is also a source of DMA requests if the number of bytes to be prefetched is not a multiple of FIFOTHRESHOLD, the remaining bytes in the FIFO can be read by the DMA channel using the last DMA request. This assumes that the number of remaining bytes to be read is known and controlled through the DMA channel programming model.

Any potentially active DMA request is cleared when the prefetch engine goes from inactive-to-active prefetch (the STARTENGINE bit is set to 1). The associated DMA channel must always be enabled after setting the STARTENGINE bit so that the out-of-date active DMA request does not trigger spurious DMA transfers.

13.3.1.4.11.4.4 Write-Posting Mode

The write-posting mode is selected when the GPMC_PREFETCH_CONFIG1[0] ACCESSMODE bit is set.

The NAND software driver must issue the correct address pointer initialization command (page program) before the engine can start writing data into the NAND memory device. The engine starts when the GPMC_PREFETCH_CONTROL[0] STARTENGINE bit is set to 1. The STARTENGINE bit clears automatically when posting completes. When all data have been written to the NAND memory device, the NAND software driver must issue the second cycle program command and monitor the status for programming process completion (adding ECC handling, if required).

If used, the ECC calculator engine must be started (configured, reset, and enabled) before the posting engine is started so that the ECC parities are calculated properly on all data written by the prefetch engine to the associated chip-select.

In write-posting mode, the GPMC_PREFETCH_CONFIG1[3] SYNCHROMODE bit must be cleared so that posting starts as soon as the STARTENGINE bit is set and the FIFO is not empty.

If the STARTENGINE bit is set after the NAND address phase (page program command), the STARTENGINE setting is effective only after the actual NAND command completion. To prevent GPMC stall during this NAND command phase, set the STARTENGINE bit field before the NAND address completion and ensure that the associated DMA channel is enabled after the NAND address phase.

The posting engine issues a write request when valid data are available from the FIFO and until the programmed GPMC_PREFETCH_CONFIG2[13-0] TRANSFERCOUNT accesses are complete.

The STARTENGINE bit clears automatically when posting completes. When all data have been written to the NAND memory device, the NAND software driver must issue the second cycle program command and monitor the status for programming process completion. The closing program command phase must be issued only when the full NAND page has been written into the NAND flash write buffer, including the spare area data and the ECC parities, if used.

Table 13-178 describes the write-posting configuration.

Table 13-178. Write-Posting Mode Configuration

Bit Field	Register	Value	Comments
STARTENGINE	GPMC_PREFETCH_CONTROL[0]	0	Write-posting engine can be configured only if STARTENGINE is set to 0.
ENGINECSSELECTOR	GPMC_PREFETCH_CONFIG1[26-24]	0 to 3	Selects the chip-select associated with a NAND device where the prefetch engine is active
ACCESSMODE	GPMC_PREFETCH_CONFIG1[0]	1	Selects write-posting mode
FIFOTHRESHOLD	GPMC_PREFETCH_CONFIG1[14-8]		Selects the maximum number of bytes read or written by the host on DMA or interrupt request
TRANSFERCOUNT	GPMC_PREFETCH_CONFIG2[13-0]		Selects the number of bytes to be read or written by the engine from/to the selected chip-select
SYNCHROMODE	GPMC_PREFETCH_CONFIG1[3]	0	Engine starts the access to chip-select as soon as STARTENGINE is set.
ENABLEOPTIMIZEDACCESS	GPMC_PREFETCH_CONFIG1[27]	0/1	See Section 13.3.1.4.11.4.6, Optimizing NAND Access Using the Prefetch and Write-Posting Engine.
CYCLEOPTIMIZATION	GPMC_PREFETCH_CONFIG1[30-28]		
ENABLEENGINE	GPMC_PREFETCH_CONFIG1[7]	1	Engine enabled
STARTENGINE	GPMC_PREFETCH_CONTROL[0]	1	Starts the prefetch engine

13.3.1.4.11.4.5 FIFO Control in Write-Posting Mode

Note

Some of the GPMC features described in this section may not be supported on this family of devices. For more information, see , *GPMC Not Supported Features*.

The FIFO can be filled directly by a device host processor or a DMA module channel.

In filling mode, the FIFO status can be monitored through the FIFOPOINTER or through the GPMC_PREFETCH_STATUS[16] FIFOTHRESHOLDSTATUS bit. FIFOPOINTER indicates the current number of available free byte places in the FIFO, and the FIFOTHRESHOLDSTATUS bit, when set, indicates that at least FIFOTHRESHOLD free byte places are available in the FIFO.

An interrupt can be issued by the GPMC if the GPMC_IRQENABLE[0] FIFOEVENTENABLE bit is set. When the interrupt is fired, the GPMC_IRQSTATUS[0] FIFOEVENTSTATUS bit is set. To clear the interrupt, enough bytes must be written to fill the FIFO or to get below the programmed threshold, and the FIFOEVENTSTATUS bit must be cleared to get further interrupt events. The FIFOEVENTSTATUS bit must always be cleared before asserting the FIFOEVENTENABLE bit to clear any out-of-date logged interrupt event. This interrupt must be enabled after enabling the STARTENGINE bit.

The posting completion can be monitored through the GPMC_PREFETCH_STATUS[13-0] COUNTVALUE bit field. COUNTVALUE indicates the current number of remaining data to be written based on the value of the TRANSFERCOUNT bit field. An interrupt is issued by the GPMC when the write-posting process completes (that is, COUNTVALUE equal to 0) if the GPMC_IRQENABLE[1] TERMINALCOUNTEVENTENABLE bit is set. When the interrupt is fired, the GPMC_IRQSTATUS[1] TERMINALCOUNTSTATUS bit is set. To clear the interrupt, the TERMINALCOUNTSTATUS bit must be cleared. The TERMINALCOUNTSTATUS bit must always be cleared before asserting the TERMINALCOUNTEVENTENABLE bit to clear any out-of-date logged interrupt event.

Note

The value of the COUNTVALUE bit field is valid only if the write-posting engine is active and started, and an interrupt is issued only when COUNTVALUE reaches 0; that is, when the posting engine automatically goes from active to inactive.

In DMA filling mode, the DMAMode bit field in the GPMC_PREFETCH_CONFIG1[2] DMAMODE bit must be set so that the GPMC issues a DMA hardware request when at least FIFOTHRESHOLD bytes-free places are available in the FIFO. The DMA channel that owns this DMA request must be programmed so that a number of bytes equal to the value programmed in the FIFOTHRESHOLD bit field are written into the FIFO during the DMA access. The DMA request remains active until the associated number of bytes has effectively been written into the FIFO, and no other DMA request can be issued until the ongoing active request completes.

Any potentially active DMA request is cleared when the prefetch engine goes from inactive-to-active prefetch (STARTENGINE set to 1). The associated DMA channel must always be enabled after setting the STARTENGINE bit so that an out-of-date active DMA request does not trigger spurious DMA transfers.

In write-posting mode, DMA or CPU fills the FIFO with no consideration for the associated byte enables. Any byte stored in the FIFO is written into the memory device.

13.3.1.4.11.4.6 Optimizing NAND Access Using the Prefetch and Write-Posting Engine

Access time to a NAND memory device can be optimized for back-to-back accesses if the associated nCS signal is not deasserted between accesses. The GPMC access engine can track prefetch engine accesses to optimize the access timing parameter programmed for the allocated chip-select, if no accesses to other chip-selects (that is, interleaved accesses) occur. Similarly, the access engine also eliminates CYCLE2CYCLEDELAY even if CYCLE2CYCLESAMECSSEN is set. This capability is limited to the prefetch and write-posting engine accesses, and accesses to a NAND memory device (through the defined chip-select memory region or through the GPMC_NAND_DATA_i location, where i = 0 to 3) are never optimized.

The GPMC_PREFETCH_CONFIG1[27] ENABLEOPTIMIZEDACCESS bit must be set to enable optimized accesses. To optimize access time, the GPMC_PREFETCH_CONFIG1[30-28] CYCLEOPTIMIZATION bit field defines the number of GPMC_FCLK cycles to be suppressed from the following timing parameters:

- RDCYCLETIME
- WRCYCLETIME
- RDACCESSTIME
- WRACCESSTIME
- CSOFFTIME
- ADVOFFTIME
- OEOFFTIME
- WEOFFTIME

Figure 13-167 shows that in the case of back-to-back accesses to the NAND flash through the prefetch engine, CYCLE2CYCLESAMECSSEN is forced to 0 when using optimized accesses. The first access uses the regular timing settings for this chip-select. All accesses after this one use settings reduced by x clock cycles, x being defined by the GPMC_PREFETCH_CONFIG1[30-28] CYCLEOPTIMIZATION bit field.

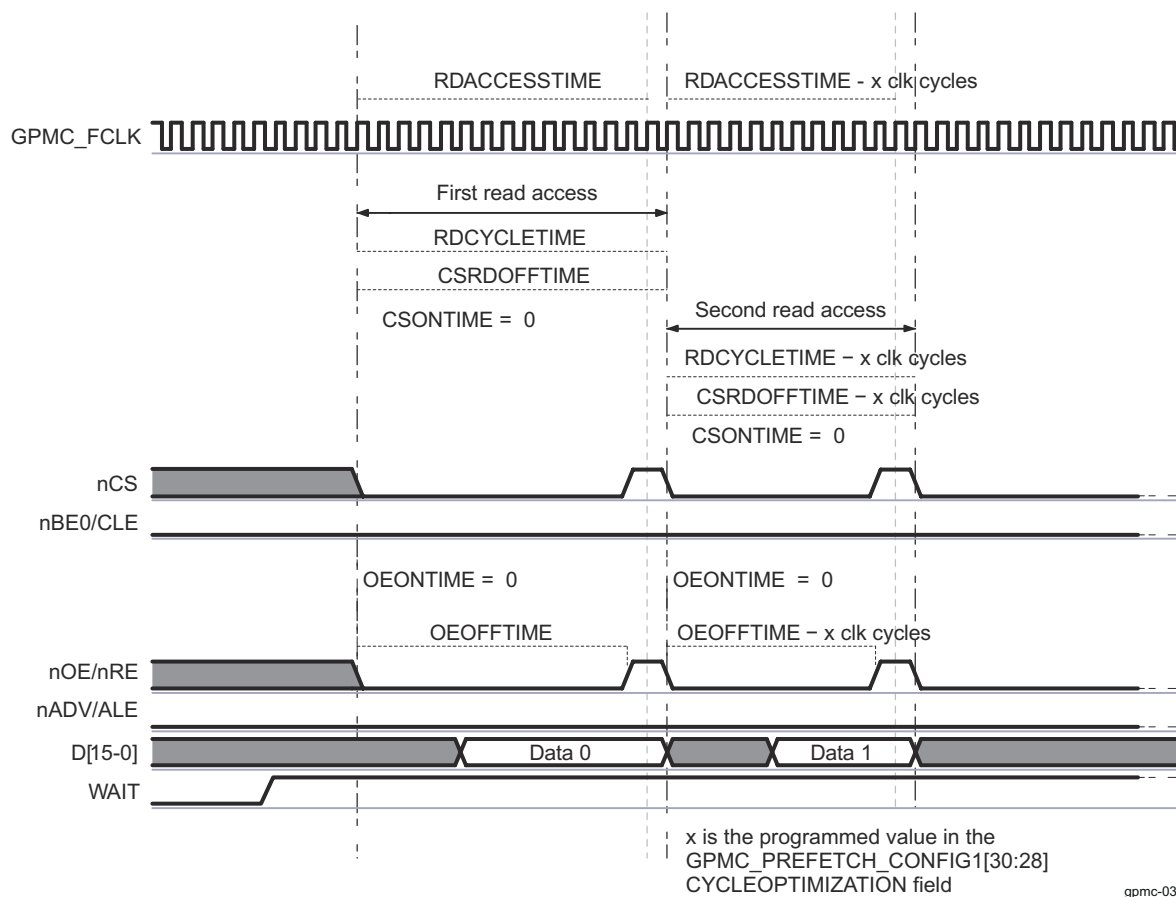

Figure 13-167. NAND Read Cycle Optimization Timing Description

gpmc-036

13.3.1.4.11.4.7 Interleaved Accesses Between Prefetch and Write-Posting Engine and Other Chip-Selects

Any on-going read or write access from the prefetch and write-posting engine is completed before an access to any other chip-select can be initiated. As a default, the arbiter uses a fixed-priority algorithm, and the prefetch and write-posting engine has the lowest priority. The maximum latency added to access starting time in this case equals the RDCYCLETIME or WRCYCLETIME (optimized or not) plus the requested BUSTURNAROUND delay for bus turnaround completion programmed for the chip-select to which the NAND device is connected.

Alternatively, a round-robin arbitration can be used to prioritize accesses to the external bus. This arbitration scheme is enabled by setting the GPMC_PREFETCH_CONFIG1[23] PFPWENROUNDROBIN bit. When a request to another chip-select is received while the prefetch and write-posting engine is active, priority is given to the new request. The request processed thereafter is the prefetch and write-posting engine request, even if another interconnect request is passed in the mean time. The engine keeps control of the bus for an additional number of requests programmed in the GPMC_PREFETCH_CONFIG1[19-16] PFPWWEIGHTEDPRIO bit field. Control is then passed to the direct interconnect request.

As an example, the round-robin arbitration scheme is selected with PFPWWEIGHTEDPRIO set to 0x2. Considering that the prefetch and write-posting engine and the interconnect interface are always requesting access to the external interface, the GPMC grants priority to the direct interconnect access for one request. The GPMC then grants priority to the engine for three requests, and finally back to the direct interconnect access, until the arbiter is reset when one of the two initiators stops initiating requests.

13.3.1.4.12 GPMC Memory Regions

Table 13-179 shows the GPMC memory regions.

Table 13-179. GPMC Memory Map

Region Name	Address Range	Size	Description
GPMC0			
GPMC0_CFG	0x00 03B00 0000 to 0x00 03B00 03FF	1 KB	Configuration registers space
GPMC0_DATA	0x00 2000 0000 to 0x00 27FF FFFF	128 MB	External memory space region

13.3.1.4.13 GPMC Use Cases and Tips

13.3.1.4.13.1 How to Set GPMC Timing Parameters for Typical Accesses

13.3.1.4.13.1.1 External Memory Attached to the GPMC Module

As discussed in the introduction to this chapter, the GPMC module supports the following external memory types:

- Asynchronous or synchronous, 8- or 16-bit-wide memory or device
- 16-bit address/data-multiplexed or non-multiplexed NOR flash device
- 8- or 16-bit NAND flash device

The following examples describe how to calculate GPMC timing parameters by showing a typical parameter setup for the access to be performed.

The example is based on a 512-Mb multiplexed NOR flash memory with the following characteristics:

- Type: NOR flash (address/data-multiplexed mode)
- Size: 512M bits
- Data Bus: 16 bits wide
- Speed: 104-MHz clock frequency
- Read access time: 80 ns

13.3.1.4.13.1.2 Typical GPMC Setup

Table 13-180 lists some of the I/Os of the GPMC module.

Table 13-180. Typical GPMC Setup Signals

Module Pin	I/O ⁽¹⁾	Description
GPMC0_FCLK	Internal	Functional clock. Acts as the time reference.
GPMC0_ICLK	Internal	Interface clock. Acts as the time reference.
GPMC0_CLKOUT	O	External clock provided to the external device for synchronous operations
GPMC0_A[21-16]	O	Address
GPMC0_AD[15-0]	I/O	Data-multiplexed with addresses A[16-1] on memory side
GPMC0_CSn[3-0]	O	Chip-selects
GPMC0_ADVn_ALE	O	Address valid enable
GPMC0_OEn_REn	O	Output enable (read access only)
GPMC0_WEn	O	Write enable (write access only)
GPMC0_WAIT[1-0]	I	Ready signal from memory device. Indicates when valid burst data is ready to be read

(1) I = Input; O = Output

Figure 13-168 shows the typical connection between the GPMC module and an attached NOR Flash memory.

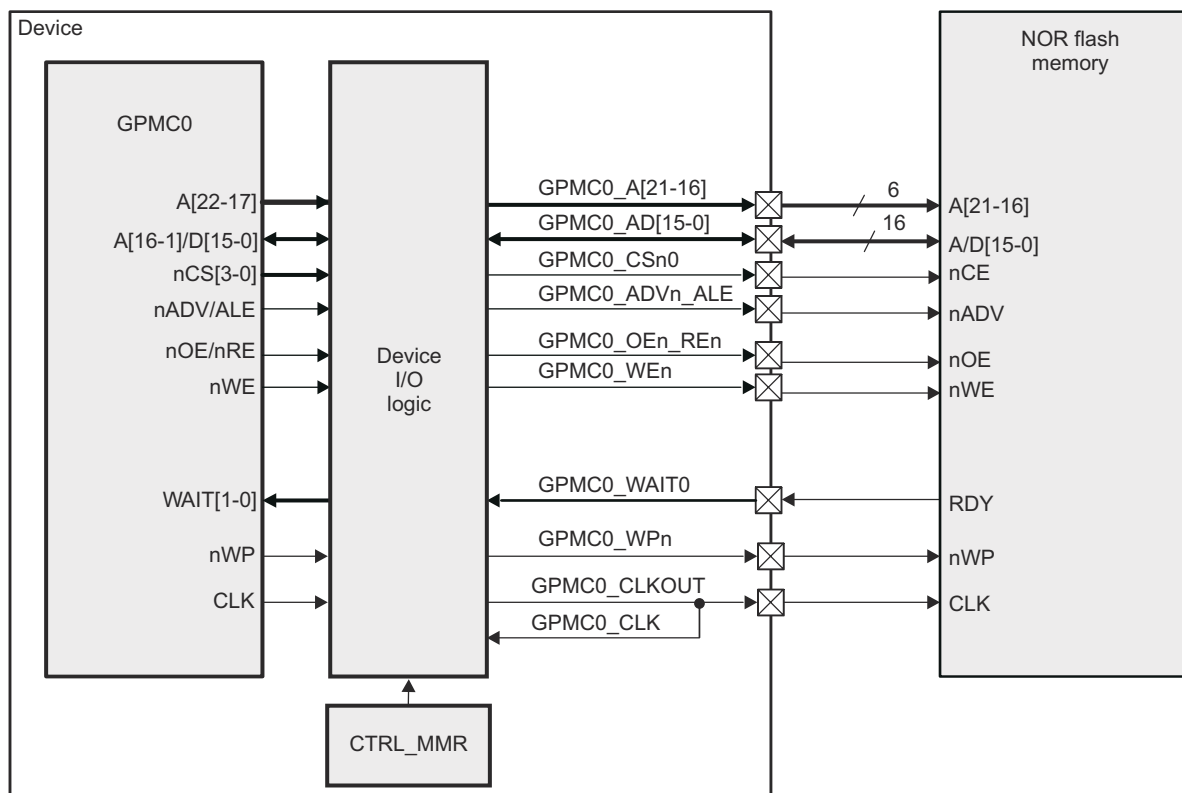

gpmc-037

Figure 13-168. GPMC Connection to an External NOR Flash Memory

The following sections demonstrate how to calculate GPMC parameters for three access types:

- Synchronous burst read
- Asynchronous read
- Asynchronous single write

13.3.1.4.13.1.2.1 GPMC Configuration for Synchronous Burst Read Access

Note

The examples in Section 13.3.1.4.13.1.2.1 through Section 13.3.1.4.13.1.2.3 are based on a clock rate of 104 MHz. See the device-specific Datasheet for the maximum frequency appropriate for this device and the memory datasheet for the maximum frequency for the particular memory device.

The clock runs at 104 MHz ($f = 104 \text{ MHz}$; $T = 9.615 \text{ ns}$).

Table 13-181 shows the timing parameters (on the memory side) that determine the parameters on the GPMC side.

Table 13-182 shows how to calculate timings for the GPMC using the memory parameters.

Figure 13-169 shows the synchronous burst read access.

Table 13-181. Useful Timing Parameters on the Memory Side

AC Read Characteristics on the Memory Side	Description	Duration (ns)
tCES	nCS setup time to clock	0
tACS	Address setup time to clock	3
tIACC	Synchronous access time	80
tBACC	Burst access time valid clock to output delay	5.2

Table 13-181. Useful Timing Parameters on the Memory Side (continued)

AC Read Characteristics on the Memory Side	Description	Duration (ns)
tCEZ	Chip-select to High-Z	7
tOEZ	Output enable to High-Z	7
tAVC	nADV setup time	6
tAVD	nADV pulse	6
tACH	Address hold time from clock	3

The following terms, which describe the timing interface between the controller and its attached device, are used to calculate the timing parameters on the GPMC side:

- Read access time (GPMC side): Time required to activate the clock + read access time requested on the memory side + data setup time required for optimal capture of a burst of data
- Data setup time (GPMC side): Ensures a good capture of a burst of data (as opposed to taking a burst of data out). One word of data is processed in one clock cycle ($T = 9.615$ ns). The read access time between two bursts of data is $tBACC = 5.2$ ns. Therefore, data setup time is a clock period – $tBACC = 4.415$ ns of data setup.
- Access completion (GPMC side): (Different from page burst access time) Time required between the last burst access and access completion: nCS/nOE hold time (nCS and nOE must be released at the end of an access. These signals are held to allow the access to complete).
- Read cycle time (GPMC side): Read access time + access completion
- Write cycle time for burst access: Not supported for NOR flash memory

Table 13-182. Calculating GPMC Timing Parameters

Parameter Name on GPMC Side	Formula	Duration (ns)	Number of Clock Cycles (F = 104 MHz)	GPMC Register Configurations
GPMC FCLK Divider	–	–	–	GPMCFCLKDIVIDER = 0x0
ClkActivation Time	min (tCES, tACS)	3	1	CLKACTIVATIONTIME = 0x1
RdAccessTime	roundmax (ClkActivationTime + tIACC + DataSetupTime)	94.03: (9.615 + 80 + 4.415)	10: roundmax (94.03 / 9.615)	RDACCESSTIME = 0xA
PageBurst RdAccessTime	roundmax (tBACC)	roundmax (5.2)	1	PAGEBURSTACCESSTIME = 0x1
RdCycleTime	RdAccess time + max (tCEZ, tOEZ)	101.03: (94.03 + 7)	11	RDCYCLETIME = 0xB
CsOnTime	tCES	0	0	CSONTIME = 0x0
CsReadOffTime	RdCycleTime	-	11	CSRDOFFTIME = 0xB
AdvOnTime	tAVC ⁽¹⁾	0	0	ADVONTIME = 0x0
AdvRdOffTime	tAVD + tAVC ⁽²⁾	12	2	ADVRDOFFTIME = 0x2
OeOnTime ⁽³⁾	(ClkActivationTime + tACH) < OeOnTime (ClkActivationTime + tIACC)	–	3, for instance	OEONTIME = 0x3
OeOffTime	RdCycleTime	–	11	OEOFFTIME = 0xB

(1) The external clock provided to the NOR flash is not yet available.

(2) $AdvRdOffTime - AdvOnTime = tAVD$; thus, $AdvRdOffTime = tAVD + AdvOnTime = tAVD + tAVC$.

(3) OeOnTime must ensure that addresses are available. It must not exceed the availability of the first burst of data.

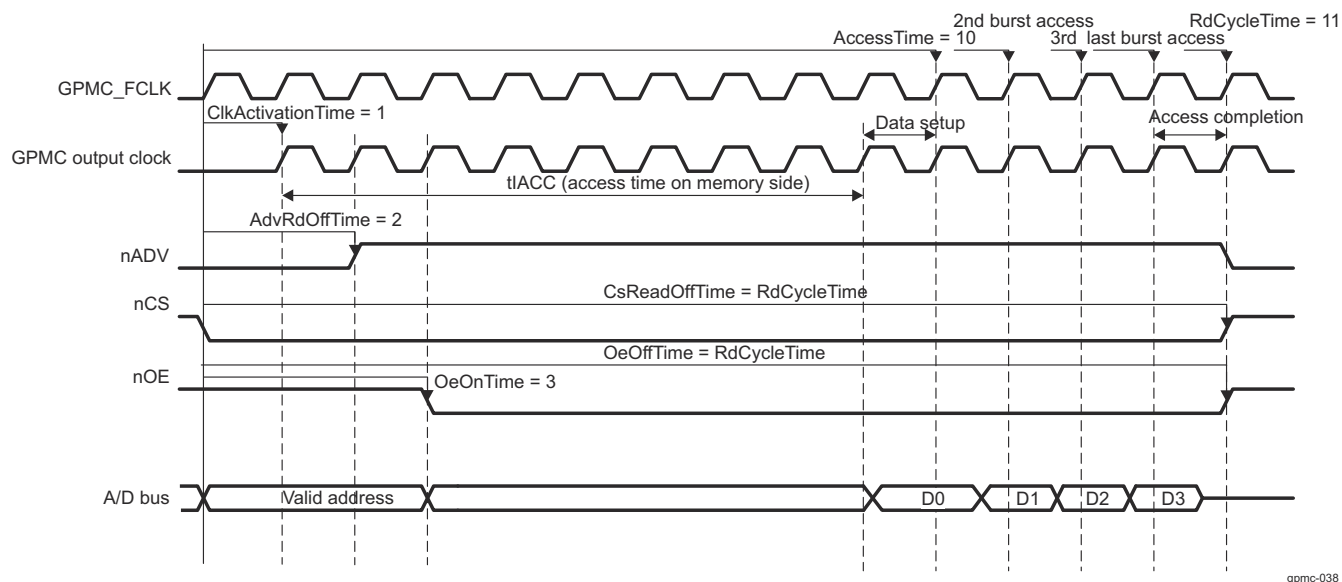

Figure 13-169. Synchronous Burst Read Access (Timing Parameters in Clock Cycles)

13.3.1.4.13.1.2.2 GPMC Configuration for Asynchronous Read Access

The clock runs at 104 MHz (f = 104 MHz; T = 9.615 ns).

Table 13-183 shows the timing parameters (on the memory side) that determine the parameters on the GPMC side.

Table 13-184 shows how to calculate timings for the GPMC using the memory parameters.

Figure 13-170 shows the asynchronous read access.

Table 13-183. AC Characteristics for Asynchronous Read Access

AC Read Characteristics on the Memory Side	Description	Duration (ns)
tCE	Read Access time from nCS low	80
tAAVDS	Address setup time to rising edge of nADV	3
tAVDP	nADV low time	6
tCAS	nCS setup time to nADV	0
tOE	Output enable to output valid	6
tOEZ	Output enable to High-Z	7

Use the following formula to calculate the RdCycleTime parameter for this typical access:

$$RdCycleTime = RdAccessTime + AccessCompletion = RdAccessTime + 1 \text{ clock cycle} + tOEZ:$$

1. On the memory side, the external memory makes the data available to the output bus. This is the memory-side read access time defined in Table 13-183: the number of clock cycles between the address capture (nADV rising edge) and the data valid on the output bus.

The GPMC requires some hold time to allow the data to be captured correctly and the access to be finished.

2. To read the data correctly, the GPMC must be configured to meet the data setup time requirement of the memory; the GPMC module captures the data on the next rising edge. This is access time on the GPMC side.
3. There must also be a data hold time for correctly reading the data (checking that there is no nOE/nCS deassertion while reading the data). This data hold time is one clock cycle (that is, RdAccessTime + 1).
4. To complete the access, nOE/nCS signals are driven to High-Z. RdAccessTime + 1 + tOEZ is the read cycle time.

5. Addresses can now be relatched and a new read cycle begun.

Table 13-184. GPMC Timing Parameters for Asynchronous Read Access

Parameter Name on GPMC Side	Formula	Duration (ns)	Number of Clock Cycles (F = 104 MHz)	GPMC Register Configurations
ClkActivationTime		n/a (asynchronous mode)		
RdAccessTime	round max (tCE)	80	10	RDACCESSTIME = 0xA
PageBurstAccessTime	N/A (single access)			
RdCycleTime	RdAccessTime + 1 cycle + tOEZ	96.615	12	RDCYCLETIME = 0xC
CsOnTime	tCAS	0	0	CSONTIME = 0x0
CsReadOffTime	RdAccessTime + 1 cycle	89.615	11	CSRDOFFTIME = 0xB
AdvOnTime	tAAVDS	3	1	ADVONTIME = 0x1
AdvRdOffTime	tAAVDS + tAVDP	9	1	ADVRDOFFTIME = 0x1
OeOnTime	OeOnTime >= AdvRdOffTime (multiplexed mode)	-	3, for instance	OEONTIME = 0x3
OeOffTime	RdAccessTime + 1 cycle	89.615	11	OEOFFTIME = 0xB

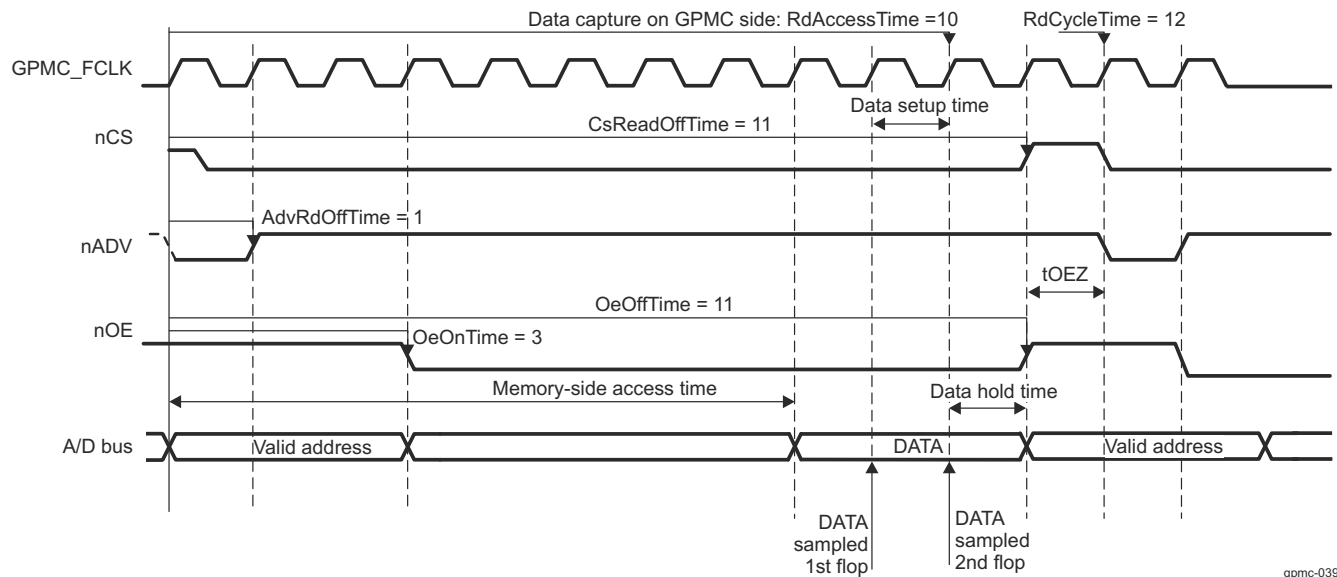

Figure 13-170. Asynchronous Single Read Access (Timing Parameters in Clock Cycles)

13.3.1.4.13.1.2.3 GPMC Configuration for Asynchronous Single Write Access

The clock runs at 104 MHz: (f = 104 MHz; T = 9.615 ns).

Table 13-186 shows how to calculate timings for the GPMC using the memory parameters.

Table 13-185 shows the timing parameters (on the memory side) that determine the parameters on the GPMC side.

Figure 13-171 shows the synchronous burst write access.

Table 13-185. AC Characteristics for Asynchronous Single Write (Memory Side)

AC Characteristics on the Memory Side	Description	Duration (ns)
tWC	Write cycle time	60
tAVDP	nADV low time	6
tWP	Write pulse width	25
tWPH	Write pulse width high	20

Table 13-185. AC Characteristics for Asynchronous Single Write (Memory Side) (continued)

AC Characteristics on the Memory Side	Description	Duration (ns)
tCS	nCS setup time to nWE	3
tCAS	nCS setup time to nADV	0
tAVSC	nADV setup time	3

For asynchronous single write access, write cycle time is $WrCycleTime = WeOffTime + AccessCompletion = WeOffTime + 1$. For the AccessCompletion, the GPMC requires one cycle of data hold time (nCS deassertion). For more information, see the device-specific Datasheet.

Table 13-186. GPMC Timing Parameters for Asynchronous Single Write

Parameter Name on GPMC Side	Formula	Duration (ns)	Number of Clock Cycles (F = 104 MHz)	GPMC Registers Configuration
ClkActivationTime		N/A (asynchronous mode)		
WdAccessTime	Applicable only to WAITMONITORING (the value is the same as for read access)			
PageBurstAccessTime		N/A (single access)		
WrCycleTime	$WeOffTime + AccessCompletion$	57.615	6	WRCYCLETIME = 0x6
CsOnTime	tCAS	0	0	CSONTIME = 0x0
CsWrOffTime	$WeOffTime + 1$	57.615	6	CSWROFFTIME = 0x6
AdvOnTime	tAVSC	3	1	ADVONTIME = 0x1
AdvWrOffTime	$tAVSC + tAVDP$	9	1	ADVWROFFTIME = 0x1
WeOnTime	tCS	3	1	WEONTIME = 0x1
WeOffTime	$tCS + tWP + tWPH$	48	5	WEOFFTIME = 0x5

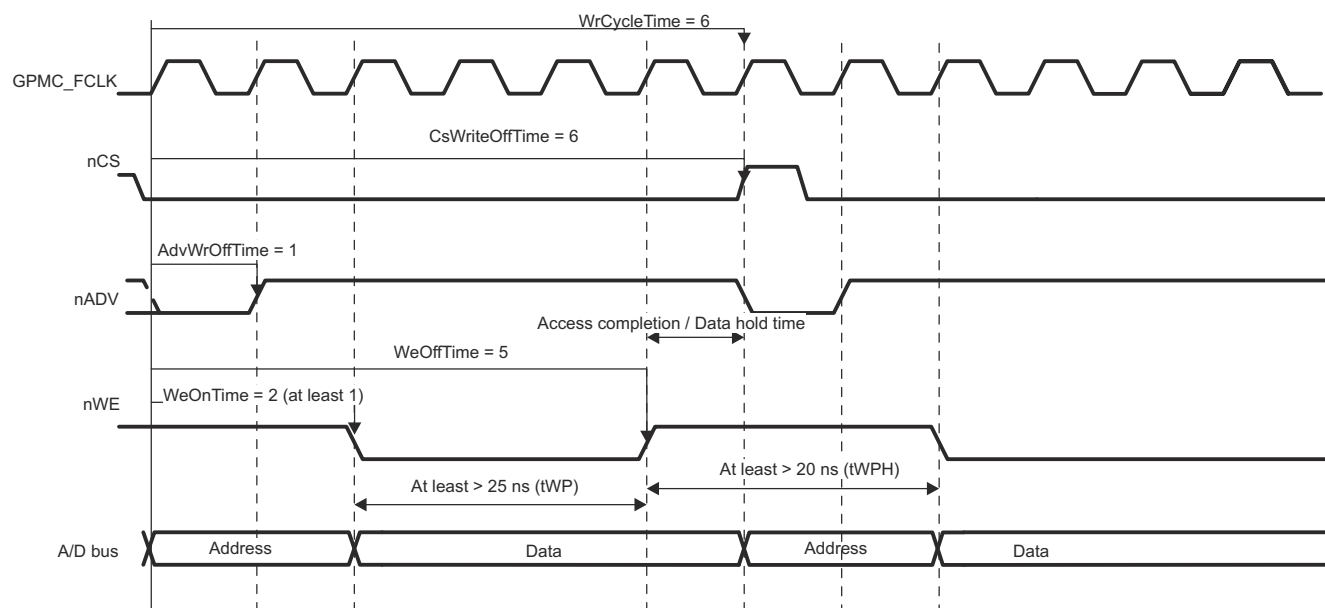

gpmc-040

Figure 13-171. Asynchronous Single Write Access (Timing Parameters in Clock Cycles)

13.3.1.4.13.2 How to Choose a Suitable Memory to Use With the GPMC

This section is intended to help the user select a suitable memory device to interface with the GPMC controller.

13.3.1.4.13.2.1 Supported Memories or Devices

NAND flash and NOR flash architectures are the two flash technologies. The GPMC supports various types of external memory or devices, basically any one that supports NAND or NOR protocols:

- 8- and 16-bit-wide asynchronous or synchronous memory or device (only 8-bit: nonburst device)
- 16-bit address and data-multiplexed NOR flash devices (pSRAM, and so on)
- 8- and 16-bit NAND flash devices

13.3.1.4.13.2.1.1 Memory Pin Multiplexing

This section describes the interfacing differences of the GPMC supported memories.

Table 13-187. Supported Memory Interfaces

Function	16-Bit Address/ Data-Multiplexed pSRAM or NOR Flash ⁽¹⁾	16-Bit NAND	8-Bit NAND
GPMC_A[22]			
GPMC_A[21]			
GPMC_A[20]			
GPMC_A[19]			
GPMC_A[18]			
GPMC_A[17]			
GPMC_A[16]			
GPMC_A[15]			
GPMC_A[14]			
GPMC_A[13]			
GPMC_A[12]			
GPMC_A[11]			
GPMC_A[10]	A26		
GPMC_A[9]	A25		
GPMC_A[8]	A24		
GPMC_A[7]	A23		
GPMC_A[6]	A22		
GPMC_A[5]	A21		
GPMC_A[4]	A20		
GPMC_A[3]	A19		
GPMC_A[2]	A18		
GPMC_A[1]	A17		
GPMC_A[0]	A16		
GPMC_AD[15]	D15 or A16	IO15	
GPMC_AD[14]	D14 or A15	IO14	
GPMC_AD[13]	D13 or A14	IO13	
GPMC_AD[12]	D12 or A13	IO12	
GPMC_AD[11]	D11 or A12	IO11	
GPMC_AD[10]	D10 or A11	IO10	
GPMC_AD[9]	D9 or A10	IO9	
GPMC_AD[8]	D8 or A9	IO8	
GPMC_AD[7]	D7 or A8		IO7
GPMC_AD[6]	D6 or A7		IO6
GPMC_AD[5]	D5 or A6		IO5
GPMC_AD[4]	D4 or A5		IO4

Table 13-187. Supported Memory Interfaces (continued)

Function	16-Bit Address/ Data-Multiplexed pSRAM or NOR Flash ⁽¹⁾	16-Bit NAND	8-Bit NAND
GPMC_AD[3]	D3 or A4		IO3
GPMC_AD[2]	D2 or A3		IO2
GPMC_AD[1]	D1 or A2		IO1
GPMC_AD[0]	D0 or A1		IO0
GPMC_CLKOUT	CLK		
GPMC_CSn0	nCS0 (chip-select)		nCE0 (chip-enable)
GPMC_CSn1	nCS1		nCE1
GPMC_CSn2	nCS2		nCE2
GPMC_CSn3	nCS3		nCE3
GPMC_ADVn_ALE	nADV (address valid)		ALE (address latch enable)
GPMC_OEn_REn	nOE (output enable)		nRE (read enable)
GPMC_WEn	nWE (Write enable)		nWE (write enable)
GPMC_BE0n_CLE	nBE0 (byte enable)		CLE (command latch enable)
GPMC_BE1n	nBE1		
GPMC_WAIT0	WAIT0		R/nB0 (ready/busy)
GPMC_WAIT1	WAIT1		R/nB1
GPMC_WPn	nWP (Write Protect)		nWP (Write Protect)

(1) Addresses seen from the device side. When interfacing to the external device, A1 is connected to the memory A0, A2 to the memory A1, and so on.

13.3.1.4.13.2.1.2 NAND Interface Protocol

NAND flash architecture, introduced in 1989, is a flash technology. NAND is a page-oriented memory device; that is, read and write accesses are done by pages. NAND achieves great density by sharing common areas of the storage transistor, which creates strings of serially connected transistors (in NOR devices, each transistor stands alone). Because of its high density NAND is best suited to devices that require high capacity data storage, such as pictures, music, and data files. NAND nonvolatility makes of it a good storage solution for many applications where mobility, low power, and speed are key factors. Low pin count and simple interface are other advantages of NAND.

Table 13-188 summarizes the NAND interface signals level applied to external device or memories.

Table 13-188. NAND Interface Bus Operations Summary

Bus Operation	CLE	ALE	nCE	nWE ⁽¹⁾	nRE ⁽¹⁾	nWP
Read (cmd input)	H	L	L	RE	H	x
Read (add input)	L	H	L	RE	H	x
Write (cmd input)	H	L	L	RE	H	H
Write (add input)	L	H	L	RE	H	H
Data input	L	L	L	RE	H	H
Data output	L	L	L	H	FE	x
Busy (during read)	x	x	H ⁽²⁾	H ⁽²⁾	H ⁽²⁾	x
Busy (during program)	x	x	x	x	x	H
Busy (during erase)	x	x	x	x	x	H
Write protect	x	x	x	x	x	L
Standby	x	x	H	x	x	H/L

(1) RE stands for rising edge; FE stands for falling edge

(2) Can be nCE high, or WE and nRE high.

13.3.1.4.13.2.1.3 NOR Interface Protocol

NOR flash architecture, introduced in 1988, is a flash technology. Unlike NAND, which is a sequential access device, NOR is directly addressable; that is, it is designed to be a random access device. NOR is best suited to devices used to store and run code or firmware, usually in small capacities. While NOR has fast read capabilities, it also has slow write and erase functions when compared to the NAND architecture.

Table 13-189 summarizes the level of the NOR interface signals applied to external devices or memories.

Table 13-189. NOR Interface Bus Operations Summary

Bus Operation	CLK	nADV	nCS	nOE	nWE	WAIT	DQ[15-0]
Read (asynchronous)	x	L	L	L	H	Asserted	Output
Read (synchronous)	Running	L	L	L	H	Driven	Output
Read (burst suspend)	Halted	x	L	H	H	Active	Output
Write	x	L	L	H	L	Asserted	Input
Output disable	x	x	L	H	H	Asserted	High-Z
Standby	x	x	H	x	x	High-Z	High-Z

13.3.1.4.13.2.1.4 Other Technologies

Other supported device types interact with the GPMC through the NOR interface protocol.

FPGA (Field-Programmable Gate Array) is a low-power integrated circuit based on an array of programmable logic blocks.

pSRAM (pseudo-static random access memory) is a low-power memory device. pSRAM is based on the DRAM cell with internal refresh and address control features, and interfaces as a synchronous NOR flash. It has synchronous write capability.

13.3.1.5 GPMC Basic Programming Model

13.3.1.5.1 GPMC High-Level Programming Model Overview

The goal of the basic high-level programming model is to introduce a top-down approach to users that need to configure the GPMC module.

[Figure 13-172](#) and [Table 13-190](#) through [Table 13-191](#) show a programming model top-level diagram for the GPMC, and a description of each step. Each block of the diagram is described in one of the following sections through a set of registers to configure.

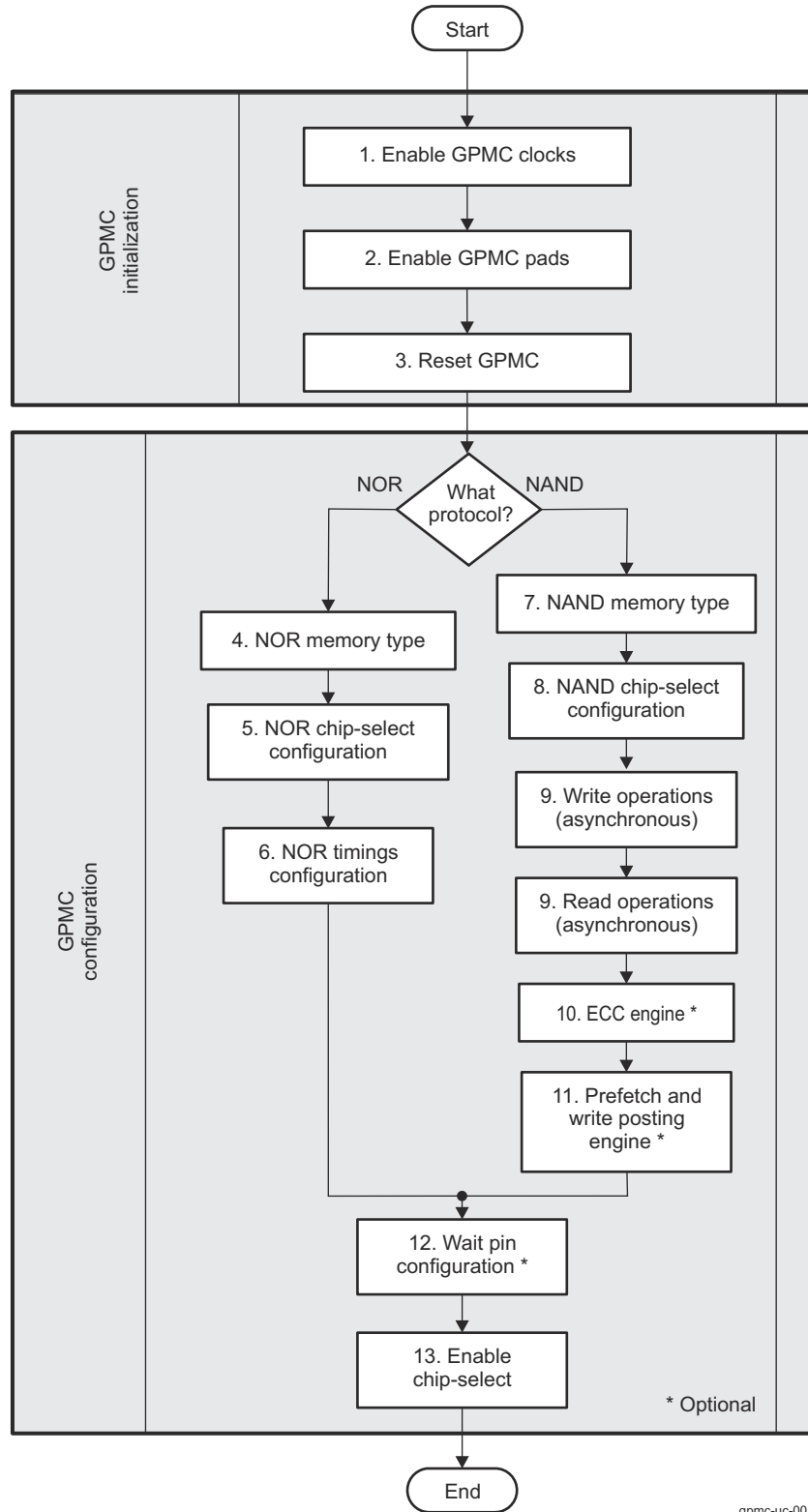

ADVANCE INFORMATION

Figure 13-172. Programming Model Top-Level Diagram

Table 13-190. GPMC Configuration in NOR Mode

Step	Description
NOR Memory Type	See Table 13-192 .

Table 13-190. GPMC Configuration in NOR Mode (continued)

Step	Description
NOR Chip-Select Configuration	See Table 13-193 .
NOR Timings Configuration	See Table 13-194 .
WAIT Pin Configuration	See Table 13-202 .
Enable Chip-Select	See Table 13-203 .

Table 13-191. GPMC Configuration in NAND Mode

Step	Description
NAND Memory Type	See Table 13-197 .
NAND Chip-Select Configuration	See Table 13-198 .
Write Operations (Asynchronous)	See Table 13-199 .
Read Operations (Asynchronous)	See Table 13-199 .
ECC Engine	See Table 13-200 .
Prefetch and Write-Posting Engine	See Table 13-201 .
WAIT Pin Configuration	See Table 13-202 .
Enable Chip-Select	See Table 13-203 .

13.3.1.5.2 GPMC Initialization

GPMC can be reset via software bit in LPSC. For more information, see , [Reset](#).

13.3.1.5.3 GPMC Configuration in NOR Mode

This section gives a generic configuration for parameters related to the NOR memory connected to the GPMC.

Table 13-192. NOR Memory Type

Subprocess Name	Register / Bit Field	Value
Set the NOR protocol.	GPMC_CONFIG1_i[11-10] DEVICETYPE	0x0
Set a device size.	GPMC_CONFIG1_i[13-12] DEVICESIZE	x
Select an address and data multiplexing protocol.	GPMC_CONFIG1_i[9] MUXADDDATA	x
Set the attached device page length.	GPMC_CONFIG1_i[24-23] ATTACHEDDEVICEPAGELENGTH	x
Set the wrapping burst capabilities.	GPMC_CONFIG1_i[31] WRAPBURST	x
Select a timing signals latencies factor.	GPMC_CONFIG1_i[4] TIMEPARAGRANULARITY	x
Select an output clock frequency ⁽¹⁾ .	GPMC_CONFIG1_i[1-0] GPMCFCLKDIVIDER	x
Choose an output clock activation time ⁽¹⁾ .	GPMC_CONFIG1_i[26-25] CLKACTIVATIONTIME	x
Set a single or multiple access for read operations ⁽¹⁾ .	GPMC_CONFIG1_i[30] READMULTIPLE	x
Set a synchronous or asynchronous mode for read operations.	GPMC_CONFIG1_i[29] READTYPE	x
Set a single or multiple access for write operations.	GPMC_CONFIG1_i[28] WRITEMULTIPLE	x
Set a synchronous or asynchronous mode for write operations.	GPMC_CONFIG1_i[27] WRITETYPE	x

(1) Applies only to synchronous configurations (or non-multiplexed asynchronous for multiple access one)

Table 13-193. NOR Chip-Select Configuration

Subprocess Name	Register/Bit Field	Value
Select the chip-select base address.	GPMC_CONFIG7_i[5-0] BASEADDRESS	x
Select the chip-select mask address.	GPMC_CONFIG7_i[11-8] MASKADDRESS	x

Table 13-194. NOR Timings Configuration

Subprocess Name	Register/Bit Field	Value
Configure adequate timing parameters in various memory modes.	See Section 13.3.1.5.6, GPMC Timing Parameters	

Table 13-195. WAIT Pin Configuration

Subprocess Name	Register/Bit Field	Value
Enable or disable WAIT pin monitoring for read operations.	GPMC_CONFIG1_i[22] WAITREADMONITORING	x
Enable or disable WAIT pin monitoring for write operations.	GPMC_CONFIG1_i[21] WAITWRITEMONITORING	x
Select a WAIT pin monitoring time.	GPMC_CONFIG1_i[19-18] WAITMONITORINGTIME	x
Choose the input WAIT pin for the chip-select.	GPMC_CONFIG1_i[17-16] WAITPINSELECT	x

Table 13-196. Enable Chip-Select

Subprocess Name	Register/Bit Field	Value
When all parameters are configured, enable the chip-select.	GPMC_CONFIG7_i[6] CSVALID	x

13.3.1.5.4 GPMC Configuration in NAND Mode

This section gives a generic configuration for parameters related to the NAND memory connected to the GPMC.

Note

Some of the GPMC features described in this section may not be supported on this family of devices. For more information, see [, GPMC Not Supported Features](#).

Table 13-197. NAND Memory Type

Subprocess Name	Register/Bit Field	Value
Set the NAND protocol.	GPMC_CONFIG1_i[11-10] DEVICETYPE	0x2
Set a device size.	GPMC_CONFIG1_i[13-12] DEVICESIZE	x
Set the address and data multiplexing protocol to non-multiplexed attached device.	GPMC_CONFIG1_i[9] MUXADDDATA	0x0
Select a timing signals latencies factor.	GPMC_CONFIG1_i[4] TIMEPARAGRANULARITY	x
Set a synchronous or asynchronous mode and a single or multiple access for read and write operations.	See Section 13.3.1.5.5, Set Memory Access .	x

Table 13-198. NAND Chip-Select Configuration

Subprocess Name	Register/Bit Field	Value
Select the chip-select base address.	GPMC_CONFIG7_i[5-0] BASEADDRESS	x
Select the chip-select minimum granularity (16MB).	GPMC_CONFIG7_i[11-8] MASKADDRESS	x

Table 13-199. Asynchronous Read and Write Operations

Subprocess Name	Register/Bit Field	Value
Configure adequate timing parameters in asynchronous modes	See Section 13.3.1.5.6, GPMC Timing Parameters .	

Table 13-200. ECC Engine

Subprocess Name	Register/Bit Field	Value
Select the ECC result register where the first ECC computation is stored (applies only to Hamming).	GPMC_ECC_CONTROL[3-0] ECCPOINTER	x ⁽²⁾
Clear all ECC result registers.	GPMC_ECC_CONTROL[8] ECCCLEAR	Write 1 to clear.
Define ECCSIZE0 and ECCSIZE1.	GPMC_ECC_SIZE_CONFIG[21-12] ECCSIZE0 and [31-22] ECCSIZE1	x ⁽¹⁾
Select the size of each of the 9 result registers (size specified by ECCSIZE0 or ECCSIZE1).	GPMC_ECC_SIZE_CONFIG[j-1] ECCjRESULTSIZ where j = 1 to 9	x

Table 13-200. ECC Engine (continued)

Subprocess Name	Register/Bit Field	Value
Select the chip-select where ECC is computed.	GPMC_ECC_CONFIG[3-1] ECCCS	x
Select the Hamming code or BCH code ECC algorithm in use.	GPMC_ECC_CONFIG[16] ECCALGORITHM	x
Select word size for ECC calculation.	GPMC_ECC_CONFIG[7] ECC16B	x
If the BCH code is used, Set an error correction capability and Select a number of sectors to process.	GPMC_ECC_CONFIG[13-12] ECCBCHTSEL and GPMC_ECC_CONFIG[6-4] ECCTOPSECTOR	x
Enable the ECC computation.	GPMC_ECC_CONFIG[0] ECCENABLE	0x1

- (1) Depends on the size of each sector in the NAND page
(2) This parameter depends on the numbers of sectors in a page.

Table 13-201. Prefetch and Write-Posting Engine

Subprocess Name	Register/Bit Field	Value
Disable the engine before configuration.	GPMC_PREFETCH_CONTROL[0] STARTENGINE	0x0
Select the chip-select associated with a NAND device where the prefetch engine is active.	GPMC_PREFETCH_CONFIG1[26-24] ENGINECSSELECTOR	x
Select access direction through prefetch engine, read or write.	GPMC_PREFETCH_CONFIG1[0] ACCESSMODE	x
Select the threshold used to issue an interrupt request.	GPMC_PREFETCH_CONFIG1[14-8] FIFOTHRESHOLD	x
Select interrupt synchronization mode.	GPMC_PREFETCH_CONFIG1[2] DMAMODE	x
Select if the engine immediately starts accessing the memory upon STARTENGINE assertion or if hardware synchronization based on a WAIT signal is used.	GPMC_PREFETCH_CONFIG1[3] SYNCHROMODE	x
Select which WAIT pin edge detector should start the engine in synchronized mode.	GPMC_PREFETCH_CONFIG1[5-4] WAITPINSELECTOR	x
Enter a number of clock cycles removed to timing parameters (for all back-to-back accesses to the NAND flash except the first one).	GPMC_PREFETCH_CONFIG1[30-28] CYCLEOPTIMIZATION	x
Enable the prefetch postwrite engine.	GPMC_PREFETCH_CONFIG1[7] ENABLEENGINE	0x1
Select the number of bytes to be read or written by the engine to the selected chip-select.	GPMC_PREFETCH_CONFIG2[13-0] TRANSFERCOUNT	x
Start the prefetch engine.	GPMC_PREFETCH_CONTROL[0] STARTENGINE	0x1

Table 13-202. WAIT Pin Configuration

Subprocess Name	Register/Bit Field	Value
Selects when the engine starts the access to chip-select.	GPMC_PREFETCH_CONFIG1[3] SYNCHROMODE	x
Select which WAIT pin edge detector should start the engine in synchronized mode.	GPMC_PREFETCH_CONFIG1[5-4] WAITPINSELECTOR	x

Table 13-203. Enable Chip-Select

Subprocess Name	Register/Bit Field	Value
When all parameters are configured, enable the chip-select.	GPMC_CONFIG7_i[6] CSVALID	x

13.3.1.5.5 Set Memory Access

Note

Some of the GPMC features described in this section may not be supported on this family of devices. For more information, see , *GPMC Not Supported Features*.

This section describes the bit field to configure to set the GPMC in various memory modes. [Table 13-204](#) and [Table 13-205](#) provide check lists for mode parameters and access type parameters, respectively.

Table 13-204. Mode Parameters Check List

Register	Bit	Name	Asynchronous				Synchronous			
			Single Read Access	Single Write Access	Multiple Read (Page) Access	Multiple Write (Page) Access	Single Read Access	Single Write Access	Multiple Read (Burst) Access	Multiple Write (Burst) Access
GPMC_CONFIG1_i	30	READMULTIPLE	0x0	Don't care	0x1 ⁽¹⁾	Not Supported	0x0	Don't care	0x1	Don't care
GPMC_CONFIG1_i	29	READTYPE	0x0	Don't care	0x0 ⁽¹⁾	Not Supported	0x1	Don't care	0x1	Don't care
GPMC_CONFIG1_i	28	WRITEMULTIPLE	Don't care	0x0	- ⁽¹⁾	Not Supported	Don't care	0x0	Don't care	0x1
GPMC_CONFIG1_i	27	WRITETYPE	Don't care	0x0	- ⁽¹⁾	Not Supported	Don't care	0x1	Don't care	0x1

(1) Multiple read is not supported in address/data-multiplexed and AAD-multiplexed modes. Multiple read is supported in non-multiplexed mode.

Table 13-205. Access Type Parameters Check List

Register	Bit	Name	Access Type		
			non-multiplexed	Address/ Data-Multiplexed	AAD-Multiplexed
GPMC_CONFIG1_i	9-8	MUXADDDATA	0x0	0x2	0x1

13.3.1.5.6 GPMC Timing Parameters

Figure 13-173 shows a programming model diagram for the NOR interfacing timing parameters.

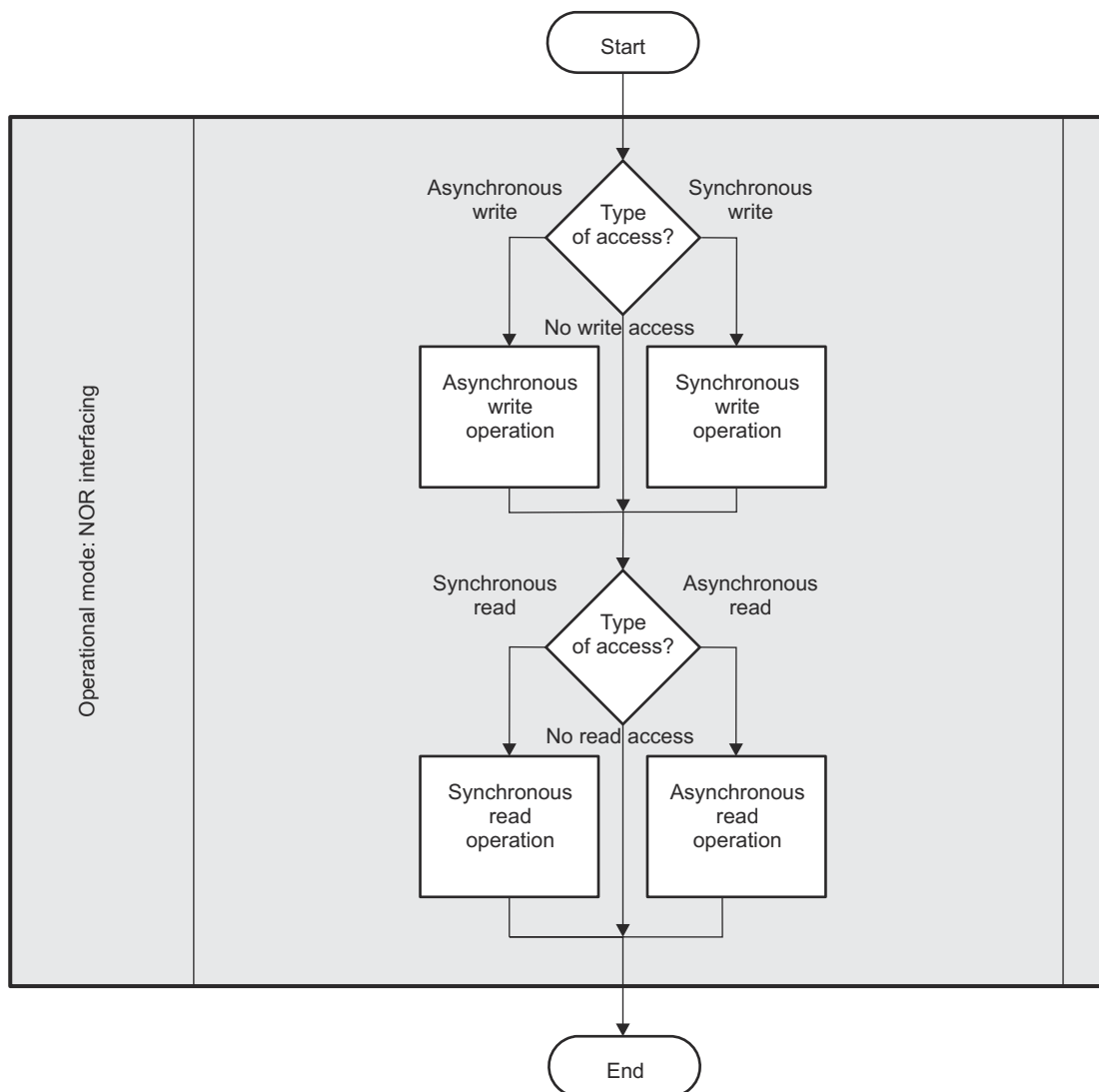

gpmc-uc-002

Figure 13-173. NOR Interfacing Timing Parameters Diagram

Table 13-206 lists the bit fields to configure adequate timing parameters in various memory modes.

Table 13-206. Timing Parameters

Register	Bit	Name	Asynchronous			Synchronous				Non-multiplexed	Addresses/Data-Multiplexed	AAD Multiplexed
			Single Read Accesses	Single Write Accesses	Multiple Read (Page) accesses	Single Read Accesses	Single Write Accesses	Multiple Read (Burst) Accesses	Multiple Write (Burst) Accesses			
GPMC_CONFIG1_i	9	MUXADDDATA	y	y	y	y	y	y	y	y	y	y
GPMC_CONFIG1_i	29	READTYPE	y		y	y		y		y	y	y
GPMC_CONFIG1_i	30	READMULTIPLE	y		y	y		y		y	y	y
GPMC_CONFIG1_i	27	WRITETYPE		y			y		y	y	y	y
GPMC_CONFIG1_i	28	WRITEMULTIPLE		y			y		y	y	y	y
GPMC_CONFIG1_i	31	WRAPBURST						y	y	y	y	y

Table 13-206. Timing Parameters (continued)

		Asynchronous			Synchronous				Access Type			
GPMC_CONFIG1_i	26-2 5	CLKACTIVATIONTIME				y	y	y	y	y	y	y
GPMC_CONFIG1_i	19-1 8	WAITMONITORINGTIME	y	y	y	y	y	y	y	y	y	y
GPMC_CONFIG1_i	4	TIMEPARAGRANULARITY	y	y	y	y	y	y	y	y	y	y
GPMC_CONFIG2_i	20-1 6	CSWROFFTIME		y			y		y	y	y	y
GPMC_CONFIG2_i	12-8	CSRDOFFTIME	y		y	y		y		y	y	y
GPMC_CONFIG2_i	7	CSEXTRADELAY	y	y	y	y	y	y	y	y	y	y
GPMC_CONFIG2_i	3-0	CSONTIME	y	y	y	y	y	y	y	y	y	y
GPMC_CONFIG3_i	30-2 8	ADVAADMUXWROFFTIME		y			y		y			y
GPMC_CONFIG3_i	30-2 9	ADVAADMUXRDOFFTIME	y		y	y		y				y
GPMC_CONFIG3_i	6-4	ADVAADMUXONTIME	y	y	y	y	y	y	y			y
GPMC_CONFIG3_i	20-1 6	ADVWROFFTIME		y			y		y	y	y	y
GPMC_CONFIG3_i	12-8	ADVRDOFFTIME	y		y	y		y		y	y	y
GPMC_CONFIG3_i	7	ADVEXTRADELAY	y	y	y	y	y	y	y	y	y	y
GPMC_CONFIG3_i	3-0	ADVONTIME	y	y	y	y	y	y	y	y	y	y
GPMC_CONFIG4_i	15-1 3	OEAADMUXOFFTIME	y	y	y	y	y	y	y			y
GPMC_CONFIG4_i	6-4	OEAADMUXONTIME	y	y	y	y	y	y	y			y
GPMC_CONFIG4_i	28-2 4	WEOFFTIME		y			y		y	y	y	y
GPMC_CONFIG4_i	23	WEEXTRADELAY		y			y		y	y	y	y
GPMC_CONFIG4_i	19-1 6	WEONTIME		y			y		y	y	y	y
GPMC_CONFIG4_i	12-8	OEOFFTIME	y		y	y		y		y	y	y
GPMC_CONFIG4_i	7	OEXTRADELAY	y		y	y		y		y	y	y
GPMC_CONFIG4_i	3-0	OEONTIME	y		y	y		y		y	y	y
GPMC_CONFIG5_i	27-2 4	PAGEBURSTACCESSTIME			y			y	y	y	y	y
GPMC_CONFIG5_i	20-1 6	RDACCESSTIME	y		y	y		y		y	y	y
GPMC_CONFIG5_i	12-8	WRCYCLETIME		y			y		y	y	y	y
GPMC_CONFIG5_i	4-0	RDCYCLETIME	y		y	y		y		y	y	y
GPMC_CONFIG6_i	28-2 4	WRACCESSTIME		y			y		y	y	y	y
GPMC_CONFIG6_i	19-1 6	WRDATAONADMUXBUS		y			y		y		y	y
GPMC_CONFIG6_i	11-8	CYCLE2CYCLEDELAY	y	y	y	y	y	y	y	y	y	y
GPMC_CONFIG6_i	7	CYCLE2CYCLESAMECSEN	y	y	y	y	y	y	y	y	y	y
GPMC_CONFIG6_i	6	CYCLE2CYCLEDIFFCSEN	y	y	y	y	y	y	y	y	y	y
GPMC_CONFIG6_i	3-0	BUSTURNAROUND	y	y	y	y	y	y	y	y	y	y
GPMC_CONFIG7_i	6	CSVALID	y	y	y	y	y	y	y	y	y	y

13.3.1.5.6.1 GPMC Timing Parameters Formulas

This section is intended to help the user calculate the GPMC timing bit field values. Formulas are not listed exhaustively.

The section describes:

- NAND flash interface timing parameters formulas
- Synchronous NOR flash timing parameters formulas
- Asynchronous NOR flash timing parameters formulas

For complete information, such as OPP and board effects on timings, see the device-specific Datasheet.

13.3.1.5.6.1.1 NAND Flash Interface Timing Parameters Formulas

This section lists formulas to calculate NAND timing parameters. This is the case when GPMC_CONFIG1_i[11-10] DEVICETYPE = 0x2. [Table 13-207](#) describes the NAND timing parameters.

Table 13-207. NAND Formulas Description

Configuration Parameter	Unit	Description
A	ns	Pulse duration – GPMC_WEn valid time
B	ns	Delay time – GPMC_CS valid to GPMC_WEn valid
C	ns	Delay time – GPMC_BE0n_CLE/GPMC_ADVn_ALE high to GPMC_WEn valid
D	ns	Delay time – GPMC_AD[15-0] valid to GPMC_WEn valid
E	ns	Delay time – GPMC_WEn invalid to GPMC_AD[15-0] invalid
F	ns	Delay time – GPMC_WEn invalid to GPMC_BE0n_CLE/GPMC_ADVn_ALE invalid
G	ns	Delay time – GPMC_WEn invalid to GPMC_CS invalid
H	ns	Cycle time – Write cycle time
I	ns	Delay time – GPMC_CS valid to GPMC_OEn_REn valid
J	ns	Setup time – GPMC_AD[15-0] valid to GPMC_OEn_REn invalid
K	ns	Pulse duration – GPMC_OEn_REn valid time
L	ns	Cycle time – Read cycle time
M	ns	Delay time – GPMC_OEn_REn invalid to GPMC_CS invalid

The configuration parameters are calculated through the following formulas. For more information, see the device-specific Datasheet.

$$A = (WEOffTime - WEOnTime) * (TimeParaGranularity + 1) * GPMC_FCLK \text{ period}$$

$$B = ((WEOnTime - CSOnTime) * (TimeParaGranularity + 1) + 0.5 * (WEEExtraDelay - CSEExtraDelay)) * GPMC_FCLK \text{ period}$$

$$C = ((WEOnTime - ADVOnTime) * (TimeParaGranularity + 1) + 0.5 * (WEEExtraDelay - ADVExtraDelay)) * GPMC_FCLK \text{ period}$$

$$D = (WEOnTime * (TimeParaGranularity + 1) + 0.5 * WEEExtraDelay) * GPMC_FCLK \text{ period}$$

$$E = (WrCycleTime - WEOffTime * (TimeParaGranularity + 1) - 0.5 * WEEExtraDelay) * GPMC_FCLK \text{ period}$$

$$F = (ADVWrOffTime - WEOffTime * (TimeParaGranularity + 1) + 0.5 * (ADVExtraDelay - WEEExtraDelay)) * GPMC_FCLK \text{ period}$$

$$G = (CSWrOffTime - WEOffTime * (TimeParaGranularity + 1) + 0.5 * (CSEExtraDelay - WEEExtraDelay)) * GPMC_FCLK \text{ period}$$

$$H = WrCycleTime * (1 + TimeParaGranularity) * GPMC_FCLK \text{ period}$$

$$I = ((OEOnTime - CSOnTime) * (TimeParaGranularity + 1) + 0.5 * (OEEExtraDelay - CSEExtraDelay)) * GPMC_FCLK \text{ period}$$

$$J = ((RdAccessTime - OEOffTime) * (TimeParaGranularity + 1) - 0.5 * OEEExtraDelay) * GPMC_FCLK \text{ period}$$

$$K = (OEOffTime - OEOnTime) * (1 + TimeParaGranularity) * GPMC_FCLK \text{ period}$$

$$L = RdCycleTime * (1 + TimeParaGranularity) * GPMC_FCLK \text{ period}$$

$$M = (CSRdOffTime - OEOffTime * (TimeParaGranularity + 1) + 0.5 * (CSEExtraDelay - OEEExtraDelay)) * GPMC_FCLK \text{ period}$$

[Figure 13-174](#) shows a simplified example of command latch cycle timing where formulas are associated with signal waves.

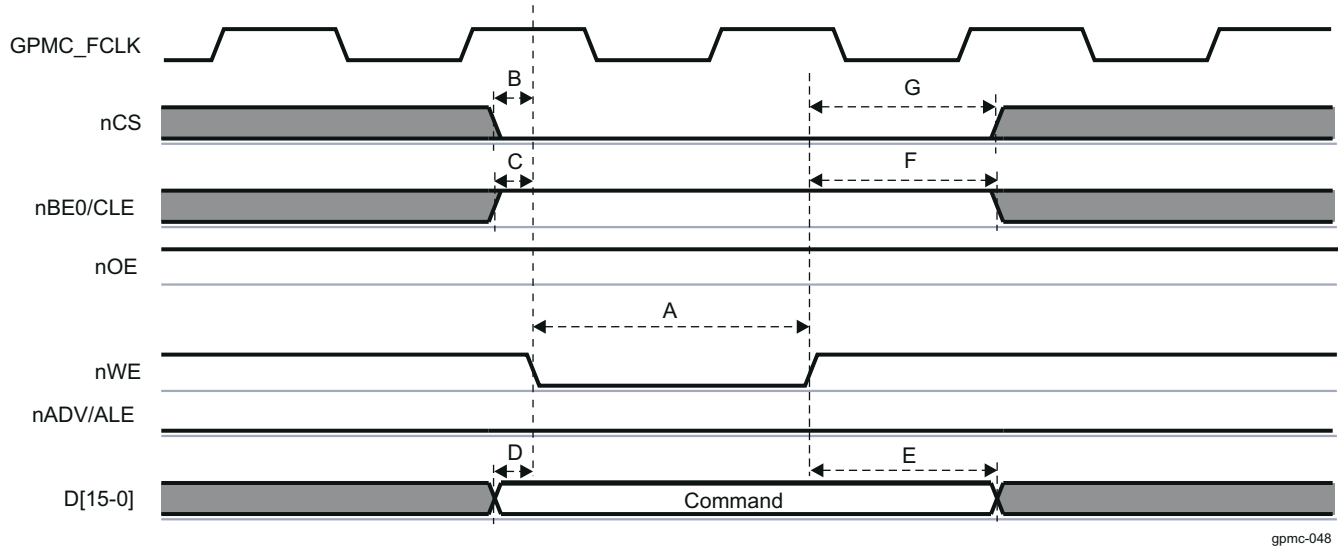

Figure 13-174. NAND Command Latch Cycle Timing Simplified Example

gpmc-048

13.3.1.5.6.1.2 Synchronous NOR Flash Timing Parameters Formulas

This section lists all formulas to calculate synchronous NOR timing parameters. This is the case when GPMC_CONFIG1_i[11-10] DEVICETYPE = 0x0 and when READTYPE or WRITETYPE are set to synchronous mode. Table 13-208 describes the synchronous NOR formulas.

Table 13-208. Synchronous NOR Formulas Description

Configuration Parameter	Unit	Description
A	ns	Pulse duration – nCS low
B	ns	Delay time – address bus valid to CLK first edge Delay time – nBE0 / nBE1 valid to CLK first edge
C	ns	Pulse duration – nBE0 / nBE1 low
D	ns	Delay time – CLK rising edge to nBE0 / nBE1 invalid Delay time – CLK rising edge to nADV/ALE invalid
E	ns	Delay time – CLK rising edge to nCS invalid Delay time – CLK rising edge to nOE/nRE invalid
F	ns	Delay time – CLK rising edge to nCS transition
G	ns	Delay time – CLK rising edge to nADV/ALE transition
H	ns	Delay time – CLK rising edge to nOE/nRE transition
I	ns	Delay time – CLK rising edge to nWE transition
J	ns	Delay time – CLK rising edge to A[16-1]/D[15-0] data bus transition Delay time – CLK rising edge to nBE0 / nBE1 transition
K	ns	Pulse duration – nADV/ALE low
L	ns	Delay time – WAIT invalid to first data latching CLK edge

The configuration parameters are calculated through the following formulas. For more information, see the device-specific Datasheet.

1. For single read accesses:

$$A = (\text{CSRDOFFTIME} - \text{CSONTIME}) * (\text{TIMEPARAGRANULARITY} + 1) * \text{GPMC_FCLK period}$$

$$C = \text{RDCYCLETIME} * (\text{TIMEPARAGRANULARITY} + 1) * \text{GPMC_FCLK period}$$

$$D = (\text{RDCYCLETIME} - \text{RDACCESSTIME}) * \text{GPMC_FCLK period}$$

$$E = (\text{CSRDOFFTIME} - \text{RDACCESSTIME}) * \text{GPMC_FCLK period}$$

2. For burst read accesses (where n is the page burst access number):
 $A = (\text{CSRDOFFTIME} - \text{CSONTIME} + (n - 1) * \text{PAGEBURSTACCESSTIME}) * (\text{TIMEPARAGRANULARITY} + 1) * \text{GPMC_FCLK period}$
 $C = (\text{RDCYCLETIME} + (n - 1) * \text{PAGEBURSTACCESSTIME}) * (\text{TIMEPARAGRANULARITY} + 1) * \text{GPMC_FCLK period}$
 $D = (\text{RDCYCLETIME} - (\text{RDACCESSTIME} + (n - 1) * \text{PAGEBURSTACCESSTIME})) * \text{GPMC_FCLK period}$
 $E = (\text{CSRDOFFTIME} - (\text{RDACCESSTIME} + (n - 1) * \text{PAGEBURSTACCESSTIME})) * \text{GPMC_FCLK period}$
3. For burst write accesses (where n is the page burst access number):
 $A = (\text{CSWROFFTIME} - \text{CSONTIME} + (n - 1) * \text{PAGEBURSTACCESSTIME}) * (\text{TIMEPARAGRANULARITY} + 1) * \text{GPMC_FCLK period}$
 $C = (\text{WRCYCLETIME} + (n - 1) * \text{PAGEBURSTACCESSTIME}) * (\text{TIMEPARAGRANULARITY} + 1) * \text{GPMC_FCLK period}$
 $D = (\text{WRCYCLETIME} - (\text{RDACCESSTIME} + (n - 1) * \text{PAGEBURSTACCESSTIME})) * \text{GPMC_FCLK period}$
 $E = (\text{CSWROFFTIME} - (\text{RDACCESSTIME} + (n - 1) * \text{PAGEBURSTACCESSTIME})) * \text{GPMC_FCLK period}$
4. For all accesses:
 For nCS falling edge (chip-select activated):
- Case where GPMC_CONFIG1_i[1-0] GPMCFCLKDIVIDER = 0x0:
 $F = 0.5 * \text{CSEXTRADELAY} * \text{GPMC_FCLK period}$
 - Case where GPMCFCLKDIVIDER = 0x1:
 $F = 0.5 * \text{CSEXTRADELAY} * \text{GPMC_FCLK period}$, when (CLKACTIVATIONTIME and CSONTIME are odd) or (CLKACTIVATIONTIME and CSONTIME are even)
 $F = (1 + 0.5 * \text{CSEXTRADELAY}) * \text{GPMC_FCLK period}$ otherwise.
 - Case where GPMCFCLKDIVIDER = 0x2:
 $F = 0.5 * \text{CSEXTRADELAY} * \text{GPMC_FCLK period}$, when (CSONTIME - CLKACTIVATIONTIME) is a multiple of 3
 $F = (1 + 0.5 * \text{CSEXTRADELAY}) * \text{GPMC_FCLK period}$, when (CSONTIME - CLKACTIVATIONTIME - 1) is a multiple of 3
 $F = (2 + 0.5 * \text{CSEXTRADELAY}) * \text{GPMC_FCLK period}$, when (CSONTIME - CLKACTIVATIONTIME - 2) is a multiple of 3
- For nCS rising edge (chip-select deactivated) in reading mode:
- Case where GPMC_CONFIG1_i[1-0] GPMCFCLKDIVIDER = 0x0:
 $F = 0.5 * \text{CSEXTRADELAY} * \text{GPMC_FCLK period}$
 - Case where GPMCFCLKDIVIDER = 0x1:
 $F = 0.5 * \text{CSEXTRADELAY} * \text{GPMC_FCLK period}$, when (CLKACTIVATIONTIME and CSRDOFFTIME are odd) or (CLKACTIVATIONTIME and CSRDOFFTIME are even)
 $F = (1 + 0.5 * \text{CSEXTRADELAY}) * \text{GPMC_FCLK period}$ otherwise.
 - Case where GPMCFCLKDIVIDER = 0x2:
 $F = 0.5 * \text{CSEXTRADELAY} * \text{GPMC_FCLK period}$, when (CSRDOFFTIME - CLKACTIVATIONTIME) is a multiple of 3
 $F = (1 + 0.5 * \text{CSEXTRADELAY}) * \text{GPMC_FCLK period}$, when (CSRDOFFTIME - CLKACTIVATIONTIME - 1) is a multiple of 3
 $F = (2 + 0.5 * \text{CSEXTRADELAY}) * \text{GPMC_FCLK period}$, when (CSRDOFFTIME - CLKACTIVATIONTIME - 2) is a multiple of 3
- For nCS rising edge (chip-select deactivated) in writing mode:
- Case where GPMC_CONFIG1_i[1-0] GPMCFCLKDIVIDER = 0x0:
 $F = 0.5 * \text{CSEXTRADELAY} * \text{GPMC_FCLK period}$
 - Case where GPMCFCLKDIVIDER = 0x1:
 $F = 0.5 * \text{CSEXTRADELAY} * \text{GPMC_FCLK period}$, when (CLKACTIVATIONTIME and CSWROFFTIME are odd) or (CLKACTIVATIONTIME and CSWROFFTIME are even)
 $F = (1 + 0.5 * \text{CSEXTRADELAY}) * \text{GPMC_FCLK period}$ otherwise.
 - Case where GPMCFCLKDIVIDER = 0x2:
 $F = 0.5 * \text{CSEXTRADELAY} * \text{GPMC_FCLK period}$, when (CSWROFFTIME - CLKACTIVATIONTIME) is a multiple of 3

$F = (1 + 0.5 * CSEXTRADelay) * GPMC_FCLK$ period, when $(CSWROFFTIME - CLKACTIVATIONTIME - 1)$ is a multiple of 3

$F = (2 + 0.5 * CSEXTRADelay) * GPMC_FCLK$ period, when $(CSWROFFTIME - CLKACTIVATIONTIME - 2)$ is a multiple of 3

For nADV falling edge (nADV activated):

- Case where GPMC_CONFIG1_i[1-0] GPMCFCLKDIVIDER = 0x0:
 $G = 0.5 * ADVEXTRADelay * GPMC_FCLK$ period
- Case where GPMCFCLKDIVIDER = 0x1:
 $G = 0.5 * ADVEXTRADelay * GPMC_FCLK$ period, when (CLKACTIVATIONTIME and ADVONTIME are odd) or (CLKACTIVATIONTIME and ADVONTIME are even)
 $G = (1 + 0.5 * ADVEXTRADelay) * GPMC_FCLK$ period otherwise.
- Case where GPMCFCLKDIVIDER = 0x2:
 $G = 0.5 * ADVEXTRADelay * GPMC_FCLK$ period, when (ADVONTIME - CLKACTIVATIONTIME) is a multiple of 3
 $G = (1 + 0.5 * ADVEXTRADelay) * GPMC_FCLK$ period, when (ADVONTIME - CLKACTIVATIONTIME - 1) is a multiple of 3
 $G = (2 + 0.5 * ADVEXTRADelay) * GPMC_FCLK$ period, when (ADVONTIME - CLKACTIVATIONTIME - 2) is a multiple of 3

For nADV rising edge (nADV deactivated) in reading mode:

- Case where GPMC_CONFIG1_i[1-0] GPMCFCLKDIVIDER = 0x0:
 $G = 0.5 * ADVEXTRADelay * GPMC_FCLK$ period
- Case where GPMCFCLKDIVIDER = 0x1:
 $G = 0.5 * ADVEXTRADelay * GPMC_FCLK$ period, when (CLKACTIVATIONTIME and ADVRDOFFTIME are odd) or (CLKACTIVATIONTIME and ADVRDOFFTIME are even)
 $G = (1 + 0.5 * ADVEXTRADelay) * GPMC_FCLK$ period otherwise.
- Case where GPMCFCLKDIVIDER = 0x2:
 $G = 0.5 * ADVEXTRADelay * GPMC_FCLK$ period, when (ADVRDOFFTIME - CLKACTIVATIONTIME) is a multiple of 3
 $G = (1 + 0.5 * ADVEXTRADelay) * GPMC_FCLK$ period, when (ADVRDOFFTIME - CLKACTIVATIONTIME - 1) is a multiple of 3
 $G = (2 + 0.5 * ADVEXTRADelay) * GPMC_FCLK$ period, when (ADVRDOFFTIME - CLKACTIVATIONTIME - 2) is a multiple of 3

For nADV rising edge (nADV deactivated) in writing mode:

- Case where GPMC_CONFIG1_i[1-0] GPMCFCLKDIVIDER = 0x0:
 $G = 0.5 * ADVEXTRADelay * GPMC_FCLK$ period
- Case where GPMCFCLKDIVIDER = 0x1:
 $G = 0.5 * ADVEXTRADelay * GPMC_FCLK$ period, when (CLKACTIVATIONTIME and ADVWROFFTIME are odd) or (CLKACTIVATIONTIME and ADVWROFFTIME are even)
 $G = (1 + 0.5 * ADVEXTRADelay) * GPMC_FCLK$ period otherwise.
- Case where GPMCFCLKDIVIDER = 0x2:
 $G = 0.5 * ADVEXTRADelay * GPMC_FCLK$ period, when (ADVWROFFTIME - CLKACTIVATIONTIME) is a multiple of 3
 $G = (1 + 0.5 * ADVEXTRADelay) * GPMC_FCLK$ period, when (ADVWROFFTIME - CLKACTIVATIONTIME - 1) is a multiple of 3
 $G = (2 + 0.5 * ADVEXTRADelay) * GPMC_FCLK$ period, when (ADVWROFFTIME - CLKACTIVATIONTIME - 2) is a multiple of 3

For nOE falling edge (nOE activated):

- Case where GPMC_CONFIG1_i[1-0] GPMCFCLKDIVIDER = 0x0:
 $H = 0.5 * OEEXTRADelay * GPMC_FCLK$ period
- Case where GPMCFCLKDIVIDER = 0x1:
 $H = 0.5 * OEEXTRADelay * GPMC_FCLK$ period, when (CLKACTIVATIONTIME and OEONTIME are odd) or (CLKACTIVATIONTIME and OEONTIME are even)

- $H = (1 + 0.5 * OEEXTRADELAY) * GPMC_FCLK$ period otherwise.
- Case where $GPMCFCLKDIVIDER = 0x2$:
 $H = 0.5 * OEEXTRADELAY * GPMC_FCLK$ period, when $(OEONTIME - CLKACTIVATIONTIME)$ is a multiple of 3
 $H = (1 + 0.5 * OEEXTRADELAY) * GPMC_FCLK$ period, when $(OEONTIME - CLKACTIVATIONTIME - 1)$ is a multiple of 3
 $H = (2 + 0.5 * OEEXTRADELAY) * GPMC_FCLK$ period, when $(OEONTIME - CLKACTIVATIONTIME - 2)$ is a multiple of 3

For nOE rising edge (nOE deactivated):

- Case where $GPMC_CONFIG1_i[1-0] GPMCFCLKDIVIDER = 0x0$:
 $H = 0.5 * OEEXTRADELAY * GPMC_FCLK$ period
- Case where $GPMCFCLKDIVIDER = 0x1$:
 $H = 0.5 * OEEXTRADELAY * GPMC_FCLK$ period, when $(CLKACTIVATIONTIME$ and $OEOFFTIME$ are odd) or $(CLKACTIVATIONTIME$ and $OEOFFTIME$ are even)
 $H = (1 + 0.5 * OEEXTRADELAY) * GPMC_FCLK$ period otherwise.
- Case where $GPMCFCLKDIVIDER = 0x2$:
 $H = 0.5 * OEEXTRADELAY * GPMC_FCLK$ period, when $(OEOFFTIME - CLKACTIVATIONTIME)$ is a multiple of 3
 $H = (1 + 0.5 * OEEXTRADELAY) * GPMC_FCLK$ period, when $(OEOFFTIME - CLKACTIVATIONTIME - 1)$ is a multiple of 3
 $H = (2 + 0.5 * OEEXTRADELAY) * GPMC_FCLK$ period, when $(OEOFFTIME - CLKACTIVATIONTIME - 2)$ is a multiple of 3

For nWE falling edge (nWE activated):

- Case where $GPMC_CONFIG1_i[1-0] GPMCFCLKDIVIDER = 0x0$:
 $I = 0.5 * WEEXTRADELAY * GPMC_FCLK$ period
- Case where $GPMCFCLKDIVIDER = 0x1$:
 $I = 0.5 * WEEXTRADELAY * GPMC_FCLK$ period, when $(CLKACTIVATIONTIME$ and $WEONTIME$ are odd) or $(CLKACTIVATIONTIME$ and $WEONTIME$ are even)
 $I = (1 + 0.5 * WEEXTRADELAY) * GPMC_FCLK$ period otherwise.
- Case where $GPMCFCLKDIVIDER = 0x2$:
 $I = 0.5 * WEEXTRADELAY * GPMC_FCLK$ period, when $(WEONTIME - CLKACTIVATIONTIME)$ is a multiple of 3
 $I = (1 + 0.5 * WEEXTRADELAY) * GPMC_FCLK$ period, when $(WEONTIME - CLKACTIVATIONTIME - 1)$ is a multiple of 3
 $I = (2 + 0.5 * WEEXTRADELAY) * GPMC_FCLK$ period, when $(WEONTIME - CLKACTIVATIONTIME - 2)$ is a multiple of 3

For nWE rising edge (nWE deactivated):

- Case where $GPMC_CONFIG1_i[1-0] GPMCFCLKDIVIDER = 0x0$:
 $I = 0.5 * WEEXTRADELAY * GPMC_FCLK$ period
- Case where $GPMCFCLKDIVIDER = 0x1$:
 $I = 0.5 * WEEXTRADELAY * GPMC_FCLK$ period, when $(CLKACTIVATIONTIME$ and $WEOFFTIME$ are odd) or $(CLKACTIVATIONTIME$ and $WEOFFTIME$ are even)
 $I = (1 + 0.5 * WEEXTRADELAY) * GPMC_FCLK$ period otherwise.
- Case where $GPMCFCLKDIVIDER = 0x2$:
 $I = 0.5 * WEEXTRADELAY * GPMC_FCLK$ period, when $(WEOFFTIME - CLKACTIVATIONTIME)$ is a multiple of 3
 $I = (1 + 0.5 * WEEXTRADELAY) * GPMC_FCLK$ period, when $(WEOFFTIME - CLKACTIVATIONTIME - 1)$ is a multiple of 3
 $I = (2 + 0.5 * WEEXTRADELAY) * GPMC_FCLK$ period, when $(WEOFFTIME - CLKACTIVATIONTIME - 2)$ is a multiple of 3

For nADV low pulse duration:

- Read operation:

- $K = (ADVRDOFFTIME - ADVONTIME) * (TIMEPARAGRANULARITY + 1) * GPMC_FCLK \text{ period}$
- Write operation:
 - $K = (ADVWROFFTIME - ADVONTIME) * (TIMEPARAGRANULARITY + 1) * GPMC_FCLK \text{ period}$

For WAIT invalid to first data latching GPMC output clock edge:

- $L = WAITMONITORINGTIME * (GPMCFCLKDIVIDER + 1) * GPMC_FCLK \text{ period} + GPMC \text{ output clock period}$

Figure 13-175 shows a simplified example of a synchronous NOR single read where formulas are associated with signal waves.

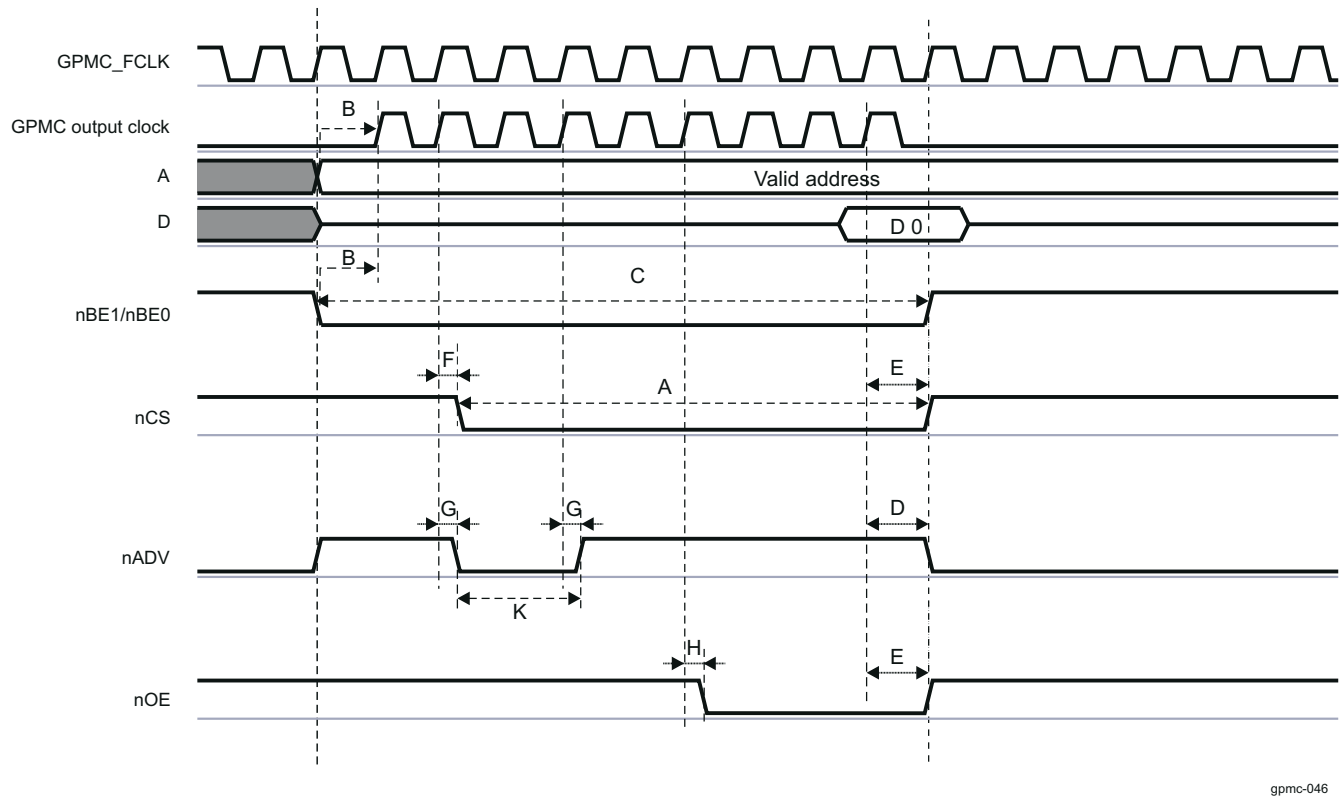

gpmc-046

Figure 13-175. Synchronous NOR Single Read Simplified Example

13.3.1.5.6.1.3 Asynchronous NOR Flash Timing Parameters Formulas

This section lists all the formulas to calculate asynchronous NOR timing parameters. This is the case when GPMC_CONFIG1_i[11-10] DEVICETYPE = 0x0 and when READTYPE or WRITETYPE are set to asynchronous mode. Table 13-209 describes the asynchronous NOR formulas.

Table 13-209. Asynchronous NOR Formulas Description

Configuration Parameter	Unit	Description
A	ns	Pulse duration – nCS low
B	ns	Delay time – nCS valid to nADV/ALE invalid
C	ns	Delay time – nCS valid to nOE/nRE invalid (single read)
D	ns	Pulse duration – address bus valid - 2nd, 3rd and 4th accesses
E	ns	Delay time – nCS valid to nWE valid
F	ns	Delay time – nCS valid to nWE invalid
G	ns	Address invalid duration between two successive R/W accesses
H	ns	Setup time – read data valid before nOE/nRE high
I	ns	Delay time – nCS valid to nOE/nRE invalid (burst read)

Table 13-209. Asynchronous NOR Formulas Description (continued)

Configuration Parameter	Unit	Description
J	ns	Delay time – address bus valid to nCS valid
		Delay time – data bus valid to nCS valid
		Delay time – nBE0 / nBE1 valid to nCS valid
K	ns	Delay time – nCS valid to nADV/ALE valid
L	ns	Delay time – nCS valid to nOE/nRE valid
M	ns	Delay time – nCS valid to first data latching edge
N	ns	Pulse duration – nBE0 / nBE1 valid time
O	ns	Delay time – nCS valid to nADV/ALE valid

The configuration parameters are calculated through the following formulas. These formulas are not exhaustive. For more information, see the device-specific Datasheet.

- nCS low pulse:
For single read: $A = (\text{CSRDOFFTIME} - \text{CSONTIME}) * (\text{TIMEPARAGRANULARITY} + 1) * \text{GPMC_FCLK period}$
For burst read: $A = (\text{CSRDOFFTIME} - \text{CSONTIME} + (\text{N} - 1) * \text{PAGEBURSTACCESSTIME}) * (\text{TIMEPARAGRANULARITY} + 1) * \text{GPMC_FCLK period}$, where N = page burst access number
For single write: $A = (\text{CSWROFFTIME} - \text{CSONTIME}) * (\text{TIMEPARAGRANULARITY} + 1) * \text{GPMC_FCLK period}$
For burst write: $A = (\text{CSWROFFTIME} - \text{CSONTIME} + (\text{N} - 1) * \text{PAGEBURSTACCESSTIME}) * (\text{TIMEPARAGRANULARITY} + 1) * \text{GPMC_FCLK period}$, where N = page burst access number
- nCS valid to nADV/ALE invalid delay:
For reading: $B = ((\text{ADVRDOFFTIME} - \text{CSONTIME}) * (\text{TIMEPARAGRANULARITY} + 1) + 0.5 * (\text{ADVEXTRADELAY} - \text{CSEXTRADELAY})) * \text{GPMC_FCLK period}$
For writing: $B = ((\text{ADVWROFFTIME} - \text{CSONTIME}) * (\text{TIMEPARAGRANULARITY} + 1) + 0.5 * (\text{ADVEXTRADELAY} - \text{CSEXTRADELAY})) * \text{GPMC_FCLK period}$
- $C = ((\text{OEOFFTIME} - \text{CSONTIME}) * (\text{TIMEPARAGRANULARITY} + 1) + 0.5 * (\text{OEEXTRADELAY} - \text{CSEXTRADELAY})) * \text{GPMC_FCLK period}$
- $D = \text{PAGEBURSTACCESSTIME} * (\text{TIMEPARAGRANULARITY} + 1) * \text{GPMC_FCLK period}$
- $E = ((\text{WEONTIME} - \text{CSONTIME}) * (\text{TIMEPARAGRANULARITY} + 1) + 0.5 * (\text{WEEXTRADELAY} - \text{CSEXTRADELAY})) * \text{GPMC_FCLK period}$
- $F = ((\text{WEOFFTIME} - \text{CSONTIME}) * (\text{TIMEPARAGRANULARITY} + 1) + 0.5 * (\text{WEEXTRADELAY} - \text{CSEXTRADELAY})) * \text{GPMC_FCLK period}$
- $G = \text{CYCLE2CYCLEDELAY} * \text{GPMC_FCLK period}$
- $H = ((\text{OEOFFTIME} - \text{RDACCESSTIME}) * (\text{TIMEPARAGRANULARITY} + 1) + 0.5 * \text{OEEXTRADELAY}) * \text{GPMC_FCLK period}$
- $I = ((\text{OEOFFTIME} + (\text{N} - 1) * \text{PAGEBURSTACCESSTIME} - \text{CSONTIME}) * (\text{TIMEPARAGRANULARITY} + 1) + 0.5 * (\text{OEEXTRADELAY} - \text{CSEXTRADELAY})) * \text{GPMC_FCLK period}$, where N = page burst access number
- $J = (\text{CSONTIME} * (\text{TIMEPARAGRANULARITY} + 1) + 0.5 * \text{CSEXTRADELAY}) * \text{GPMC_FCLK period}$
- $K = ((\text{ADVONTIME} - \text{CSONTIME}) * (\text{TIMEPARAGRANULARITY} + 1) + 0.5 * (\text{ADVEXTRADELAY} - \text{CSEXTRADELAY})) * \text{GPMC_FCLK period}$
- $L = ((\text{OEONTIME} - \text{CSONTIME}) * (\text{TIMEPARAGRANULARITY} + 1) + 0.5 * (\text{OEEXTRADELAY} - \text{CSEXTRADELAY})) * \text{GPMC_FCLK period}$
- $M = ((\text{RDACCESSTIME} - \text{CSONTIME}) * (\text{TIMEPARAGRANULARITY} + 1) - 0.5 * \text{CSEXTRADELAY}) * \text{GPMC_FCLK period}$
- nBE0 /nBE1 pulse:
For single read: $N = \text{RDCYCLETIME} * (\text{TIMEPARAGRANULARITY} + 1) * \text{GPMC_FCLK period}$
For burst read: $N = (\text{RDCYCLETIME} + (\text{N} - 1) * \text{PAGEBURSTACCESSTIME}) * (\text{TIMEPARAGRANULARITY} + 1) * \text{GPMC_FCLK period}$, where N = page burst access number

For burst write: $N = (WRCYCLETIME + (N - 1) * PAGEBURSTACCESSTIME) * (TIMEPARAGRANULARITY + 1) * GPMC_FCLK$ period, where N = page burst access number

- $O = ((WRCYCLETIME + (N - 1) * PAGEBURSTACCESSTIME - CSONTIME) * (TIMEPARAGRANULARITY + 1) + 0.5 * (ADVEXTRADELAY - CSEXTRADELAY)) * GPMC_FCLK$ period

Figure 13-176 shows a simplified example of an asynchronous NOR single write where formulas are associated with signal waves.

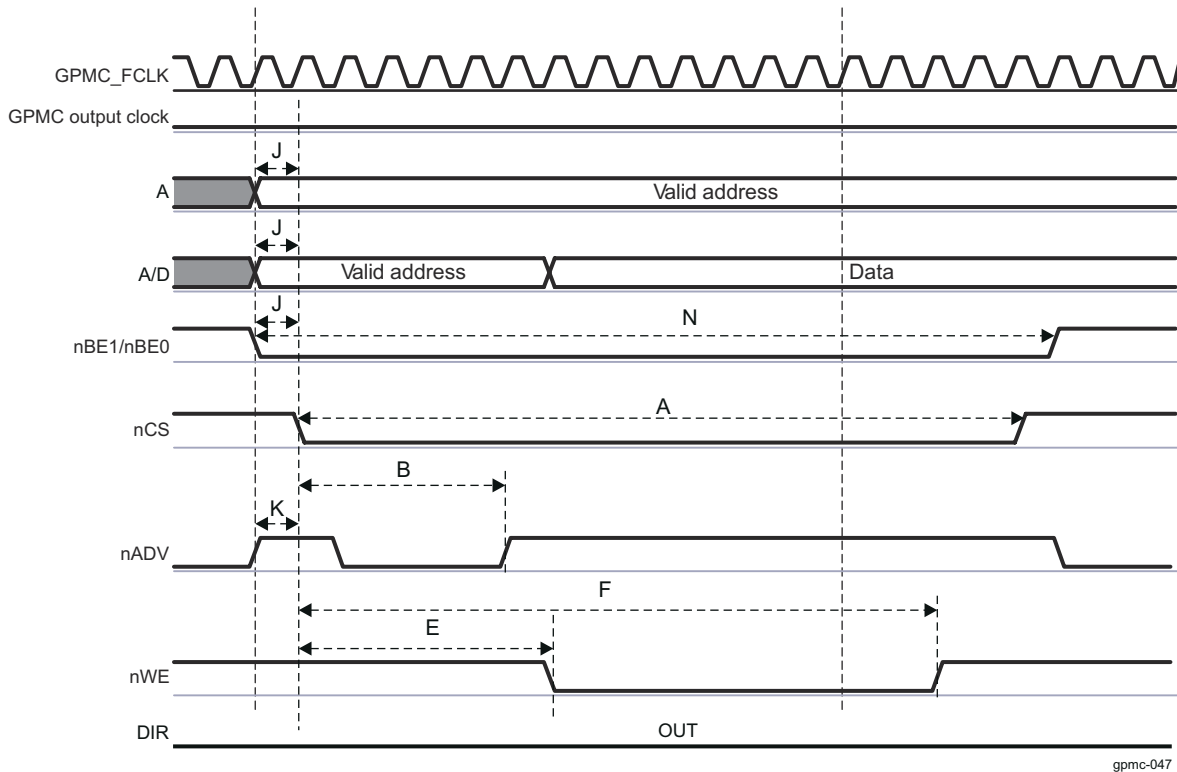

Figure 13-176. Asynchronous NOR Single Write Simplified Example

Note

Write multiple access is not supported in asynchronous mode. If WRITEMULTIPLE is enabled with WRITETYPE as asynchronous, the GPMC processes single asynchronous accesses.

13.3.2 Error Location Module (ELM)

This section describes the Error Location Module (ELM) for the device.

13.3.2.1 ELM Overview	1269
13.3.2.2 ELM Integration	1271
13.3.2.3 ELM Functional Description	1272
13.3.2.4 ELM Basic Programming Model	1275

13.3.2.1 ELM Overview

The ELM extracts error addresses from generated syndrome polynomials.

The ELM is used with the GPMC. Syndrome polynomials generated on-the-fly when reading a NAND flash page and stored in GPMC registers are passed to the ELM. A host processor can then correct the data block by flipping the bits to which the ELM error-location outputs point.

When reading from NAND flash memories, some level of error-correction is required. In the case of NAND modules with no internal correction capability, sometimes referred to as *bare NANDs*, the correction process is delegated to the memory controller. ELM can be also used to support parallel NOR flash or NAND flash.

The General-Purpose Memory Controller (GPMC) probes data read from an external NAND flash and uses this to compute checksum-like information, called syndrome polynomials, on a per-block basis. Each syndrome polynomial gives a status of the read operations for a full block, including 512 bytes of data, parity bits, and an optional spare-area data field, with a maximum block size of 1023 bytes. Computation is based on a Bose-Chaudhuri-Hocquenghem (BCH) algorithm. The ELM extracts error addresses from these syndrome polynomials.

Based on the syndrome polynomial value, the ELM can detect errors, compute the number of errors, and give the location of each error bit. The actual data is not required to complete the error-correction algorithm. Errors can be reported anywhere in the NAND flash block, including in the parity bits.

The maximum acceptable number of errors that can be corrected depends on a programmable configuration parameter. 4-, 8-, and 16-bit error-correction levels are supported. The ELM depends on a static and fixed definition of the generator polynomial for each error-correction level that corresponds to the generator polynomials defined in the GPMC (there are three fixed polynomial for the three correction error levels). A larger number of errors than the programmed error-correction level may be detected, but the ELM cannot correct them all. The offending block is then tagged as *uncorrectable* in the associated computation exit status register. If the computation is successful, that is, if the number of errors detected does not exceed the maximum value authorized for the chosen correction capability, the exit status register contains the information on the number of detected errors.

When the error-location process completes, an interrupt is triggered to inform the software that its status can be checked. The number of detected errors and their locations in the NAND block can be retrieved from the module through register accesses.

shows the ELM allocation across .

Figure 13-177 shows the ELM0 module overview.

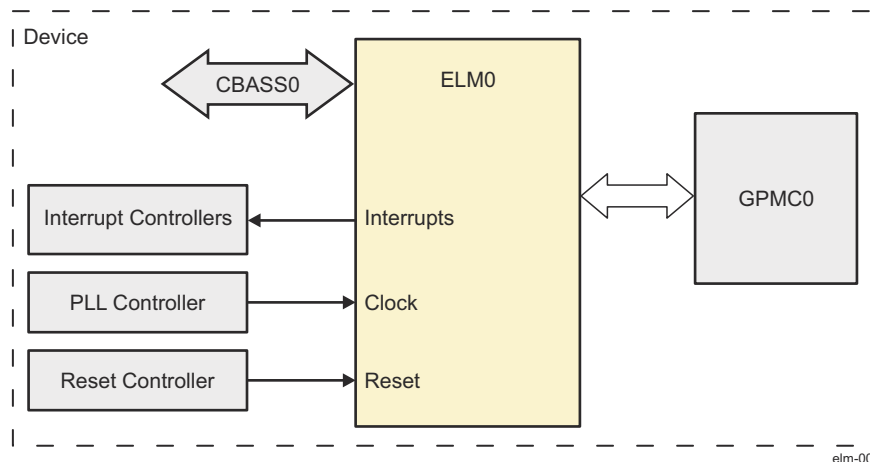

Figure 13-177. ELM0 Overview

13.3.2.1.1 ELM Features

The ELM has the following features:

- 4, 8, and 16 bits per 512-byte block error-location, based on BCH algorithms
- Eight simultaneous processing contexts
- Page-based and continuous modes
- Interrupt generation on error-location process completion:
 - When the full page has been processed in page mode
 - For each syndrome polynomial in continuous mode.

13.3.2.1.2 ELM Not Supported Features

The following features are not supported on this family of devices:

- Local power management of clock activity

13.3.2.2 ELM Integration

This section describes module integration in the device, including information about clocks, resets, and hardware requests.

13.3.2.3 ELM Functional Description

The ELM0 module is hereinafter referred to as ELM.

The ELM is designed around the error-location engine, which handles the computation based on the input syndrome polynomials.

The ELM maps the error-location engine to a standard interconnect interface by using a set of registers to control inputs and outputs.

13.3.2.3.1 ELM Software Reset

To perform a software reset, set the ELM_SYSCONFIG[1] SOFTRESET bit to 1. The ELM_SYSSTATUS[0] RESETDONE bit indicates that the software reset is complete when its value is 1. When the software reset completes, the ELM_SYSCONFIG[1] SOFTRESET bit is automatically reset.

13.3.2.3.2 ELM Power Management

Note

Some of the ELM features described in this section may not be supported on this family of devices. For more information, see [Section 13.3.2.1.2, ELM Not Supported Features](#).

[Table 13-210](#) describes the power-management features available to the ELM.

Table 13-210. Local Power-Management Features

Feature	Registers	Description
Clock autogating	ELM_SYSCONFIG[0] AUTOGATING	This bit allows a local power optimization inside the module by gating the ELM_FICLK clock upon the interface activity.
Idle modes	ELM_SYSCONFIG[4-3] SIDLEMODE	Force-idle, no-idle, and smart-idle modes are available.
Clock activity	ELM_SYSCONFIG[8] CLOCKACTIVITY	The clock can be switched off or maintained.

13.3.2.3.3 ELM Interrupt Requests

[Table 13-211](#) lists the event flags, and their masks, that can cause module interrupts asserting the signal.

Table 13-211. ELM Events

Event Flag	Event Mask	Description
ELM_IRQSTATUS[8] PAGE_VALID	ELM_IRQENABLE[8] PAGE_MASK	Page interrupt
ELM_IRQSTATUS[7] LOC_VALID_7	ELM_IRQENABLE[7] LOCATION_MASK_7	Error-location interrupt for syndrome polynomial 7
ELM_IRQSTATUS[6] LOC_VALID_6	ELM_IRQENABLE[6] LOCATION_MASK_6	Error-location interrupt for syndrome polynomial 6
ELM_IRQSTATUS[5] LOC_VALID_5	ELM_IRQENABLE[5] LOCATION_MASK_5	Error-location interrupt for syndrome polynomial 5
ELM_IRQSTATUS[4] LOC_VALID_4	ELM_IRQENABLE[4] LOCATION_MASK_4	Error-location interrupt for syndrome polynomial 4
ELM_IRQSTATUS[3] LOC_VALID_3	ELM_IRQENABLE[3] LOCATION_MASK_3	Error-location interrupt for syndrome polynomial 3
ELM_IRQSTATUS[2] LOC_VALID_2	ELM_IRQENABLE[2] LOCATION_MASK_2	Error-location interrupt for syndrome polynomial 2
ELM_IRQSTATUS[1] LOC_VALID_1	ELM_IRQENABLE[1] LOCATION_MASK_1	Error-location interrupt for syndrome polynomial 1
ELM_IRQSTATUS[0] LOC_VALID_0	ELM_IRQENABLE[0] LOCATION_MASK_0	Error-location interrupt for syndrome polynomial 0

13.3.2.3.4 ELM Processing Initialization

ELM_LOCATION_CONFIG global setting parameters must be set before using the error-location engine. The ELM_LOCATION_CONFIG[1-0] ECC_BCH_LEVEL bit field defines the error-correction level used

(4-, 8-, or 16-bit error correction). The ELM_LOCATION_CONFIG[26-16] ECC_SIZE bit field defines the maximum buffer length beyond which the engine processing no longer looks for errors.

Software can choose to use the ELM in continuous mode or page mode. If all ELM_PAGE_CTRL[i] SECTOR_i bits (i is the syndrome polynomial number, where i = 0 to 7) are reset, continuous mode is used. In any other case, page mode is implicitly selected.

- Continuous mode: Each syndrome polynomial is processed independently. Results for a syndrome can be retrieved and acknowledged at any time, regardless of the status of the other seven processing contexts.
- Page mode: Syndrome polynomials are grouped into atomic entities: only one page can be processed at any given time, even if all eight contexts are not used for this page. Unused contexts are lost and cannot be affected to any other processing. The full page must be acknowledged and cleared before moving to the next page.

For completion interrupts to be generated correctly, all ELM_IRQENABLE[i] LOCATION_MASK_i bits (where i = 0 to 7) must be forced to 0 when in page mode, and set to 1 in continuous mode. Additionally, the ELM_IRQENABLE[8] PAGE_MASK bit must be set to 1 when in page mode.

Software initiates error-location processing by writing a syndrome polynomial into one of the eight possible register sets. Each of these register sets includes seven registers: ELM_SYNDROME_FRAGMENT_0_i to ELM_SYNDROME_FRAGMENT_6_i. The first six registers can be written in any order, but ELM_SYNDROME_FRAGMENT_6_i must be written last because it includes the validity bit, which instructs the ELM that this syndrome polynomial must be processed (the ELM_SYNDROME_FRAGMENT_6_i[16] SYNDROME_VALID bit).

As soon as one validity bit is asserted (ELM_SYNDROME_FRAGMENT_6_i[16] SYNDROME_VALID = 0x1, where i = 0 to 7), error-location processing can start for the corresponding syndrome polynomial. The associated ELM_LOCATION_STATUS_i and ELM_ERROR_LOCATION_0_i to ELM_ERROR_LOCATION_15_i registers (where i = 0 to 7) are not reset. Software must not consider them until the corresponding ELM_IRQSTATUS[i] LOC_VALID_i bit is set.

13.3.2.3.5 ELM Processing Sequence

While the error-location engine is busy processing one syndrome polynomial, further syndrome polynomials can be written. They are processed when the current processing completes.

The engine completes early when:

- No error is detected; that is, when the ELM_LOCATION_STATUS_i[8] ECC_CORRECTABLE bit is set to 1 and the ELM_LOCATION_STATUS_i[4-0] ECC_NB_ERRORS bit field is set to 0x0.
- Too many errors are detected; that is, when the ELM_LOCATION_STATUS_i[8] ECC_CORRECTABLE bit is set to 0 while the ELM_LOCATION_STATUS_i[4-0] ECC_NB_ERRORS bit field is set with the value output by the error-location engine. The reported number of errors is not ensured if ECC_CORRECTABLE is 0.

If the engine completes early, the associated error-location registers ELM_ERROR_LOCATION_0_i to ELM_ERROR_LOCATION_15_i (where i = 0 to 7) are not updated.

In all other cases, the engine goes through the entire error-location process. Each time an error location is found, it is logged in the associated ECC_ERROR_LOCATION bit field. The first error detected is logged in the ELM_ERROR_LOCATION_0_i[12-0] ECC_ERROR_LOCATION bit field; the second is logged in the ELM_ERROR_LOCATION_1_i[12-0] ECC_ERROR_LOCATION bit field, and so on.

Table 13-212 describes the ELM_LOCATION_STATUS_i value decoding.

Table 13-212. ELM_LOCATION_STATUS_i Value Decoding

ECC_CORRECTABLE Value	ECC_NB_ERRORS Value	Status	Number of Errors Detected	Action Required
1	0	OK	0	None
1	≠ 0	OK	ECC_NB_ERRORS	Correct the data buffer read based on the ELM_ERROR_LOCATION_0_i to ELM_ERROR_LOCATION_15_i results.

Table 13-212. ELM_LOCATION_STATUS_i Value Decoding (continued)

0	Any	Failed	Unknown	Software-dependent
---	-----	--------	---------	--------------------

13.3.2.3.6 ELM Processing Completion

When the processing for a given syndrome polynomial completes, its ELM_SYNDROME_FRAGMENT_6_i[16] SYNDROME_VALID bit is reset. It must not be set again until the exit status registers, ELM_LOCATION_STATUS_i (where i = 0 to 7) for this processing are checked. Failure to comply with this rule leads to potential loss of the first polynomial process data output.

The error-location engine signals the process completion to the ELM. When this event is detected, the corresponding ELM_IRQSTATUS[i] LOC_VALID_i bit (where i = 0 to 7) is set. The processing exit status is available from the associated ELM_LOCATION_STATUS_i register, and error locations are stored in order in the ECC_ERROR_LOCATION bit fields. Software must read only valid error-location registers based on the number of errors detected and located.

Immediately after the error-location engine completes, a new syndrome polynomial can be processed, if any is available, as reported by the ELM_SYNDROME_FRAGMENT_6_i[16] SYNDROME_VALID bit, depending on the configured error-correction level. If several syndrome polynomials are available, a round-robin arbitration is used to select one for processing.

In continuous mode (that is, all bits in ELM_PAGE_CTRL are reset), an interrupt is triggered whenever a ELM_IRQSTATUS[i] LOC_VALID_i bit is asserted. Software must read the ELM_IRQSTATUS register to determine which polynomial is processed and retrieve the exit status and error locations (ELM_LOCATION_STATUS_i and ELM_ERROR_LOCATION_0_i to ELM_ERROR_LOCATION_15_i). When done, software must clear the corresponding ELM_IRQSTATUS[i] LOC_VALID_i bit by setting it to 1. Other status bits must be set to 0 so that other interrupts are not unintentionally cleared. When using this mode, the ELM_IRQSTATUS[8] PAGE_VALID interrupt is never triggered.

In page mode, the module does not trigger interrupts for the processing completion of each polynomial because the ELM_IRQENABLE[i] LOCATION_MASK_i bits are cleared. A page is defined using the ELM_PAGE_CTRL register. Each SECTOR_i bit set means the corresponding polynomial i is part of the page processing. A page is fully processed when all tagged polynomials have been processed, as logged in the ELM_IRQSTATUS[i] LOC_VALID_i bits. The module triggers an ELM_IRQSTATUS[8] PAGE_VALID interrupt whenever it detects that the full page has been processed. To make sure the next page can be correctly processed, all status bits in the ELM_IRQSTATUS register must be cleared by using a single atomic-write access.

Note

Do not modify page setting parameters in the ELM_PAGE_CTRL register unless the engine is idle, no polynomial input is valid, and all interrupts have been cleared.

Because no polynomial-level interrupt is triggered in page mode, polynomials cleared in the ELM_PAGE_CTRL[i] SECTOR_i bits (where i = 0 to 7) are processed as usual, but are essentially ignored. Software must manually poll the ELM_IRQSTATUS bits to check for their status.

13.3.2.4 ELM Basic Programming Model

13.3.2.4.1 ELM Low-Level Programming Model

13.3.2.4.1.1 Processing Initialization

Table 13-213. ELM Processing Initialization

Step	Register/Bit Field/Programming Model	Value
Resets the module.	ELM_SYSCONFIG[1] SOFTRESET	0x1
Wait until reset is done.	ELM_SYSSTATUS[0] RESETDONE	0x1
Configure the slave interface power management.	ELM_SYSCONFIG[4-3] SIDLEMODE	Set value
Defines the error-correction level used.	ELM_LOCATION_CONFIG[1-0] ECC_BCH_LEVEL	Set value
Defines the maximum buffer length.	ELM_LOCATION_CONFIG[26-16] ECC_SIZE	Set value
Sets the ELM in continuous mode or page mode.	ELM_PAGE_CTRL	Set value
IF continuous mode is used:	All ELM_PAGE_CTRL[i] SECTOR_i (where i = 0 to 7)	0x0
Enable interrupt for syndrome polynomial i.	ELM_IRQENABLE[i] LOCATION_MASK_i	0x1
ELSE (page mode is used):	One syndrome polynomial i is set ELM_PAGE_CTRL[i] SECTOR_i (where i = 0 to 7)	0x1
Disable all interrupts for syndrome polynomial and enable PAGE_MASK interrupt.	All ELM_IRQENABLE[i] LOCATION_MASK_i = 0x0 and ELM_IRQENABLE[8] PAGE_MASK = 0x1	Set value
ENDIF		Set value
Set the input syndrome polynomial i.	ELM_SYNDROME_FRAGMENT_0_i	Set value
	ELM_SYNDROME_FRAGMENT_1_i	Set value
	ELM_SYNDROME_FRAGMENT_5_i	Set value
	ELM_SYNDROME_FRAGMENT_6_i	Set value
Initiates the computation process.	ELM_SYNDROME_FRAGMENT_6_i[16] SYNDROME_VALID	0x1

13.3.2.4.1.2 Read Results

The engine goes through the entire error-location process and results can be read. [Table 13-214](#) and [Table 13-215](#) describe the processing completion for continuous and page modes, respectively.

Table 13-214. ELM Processing Completion for Continuous Mode

Step	Register/Bit Field/Programming Model	Value
Wait until process is complete for syndrome polynomial i: Wait until the interrupt is generated, or poll the status register.		
Read for which i the error-location process is complete.	ELM_IRQSTATUS[i] LOC_VALID_i	0x1
IF the process fails (too many errors):	ELM_LOCATION_STATUS_i[8] ECC_CORRECTABLE	0x0
It is software dependant.		
ELSE (process successful, the engine completes):	ELM_LOCATION_STATUS_i[8] ECC_CORRECTABLE	0x1
Read the number of errors.	ELM_LOCATION_STATUS_i[4-0] ECC_NB_ERRORS	
Read the error-location bit addresses for syndrome polynomial i of the ECC_NB_ERRORS first registers. Software must correct errors in the data buffer.	ELM_ERROR_LOCATION_0_i[12-0] ECC_ERROR_LOCATION	
	ELM_ERROR_LOCATION_1_i[12-0] ECC_ERROR_LOCATION	
	...	
	ELM_ERROR_LOCATION_15_i[12-0] ECC_ERROR_LOCATION	
ENDIF		
Clear the corresponding i interrupt.	ELM_IRQSTATUS[i] LOC_VALID_i	0x1

A new syndrome polynomial can be processed after the end of processing (ELM_SYNDROME_FRAGMENT_6_i[16] SYNDROME_VALID = 0x0) and after the exit status register check (ELM_LOCATION_STATUS_i).

Table 13-215. ELM Processing Completion for Page Mode

Step	Register/Bit Field/Programming Model	Value
Wait until process is complete for syndrome polynomial i : Wait until the interrupt is generated, or poll the status register.		
Wait for page completed interrupt: All error locations are valid.	ELM_IRQSTATUS[8] PAGE_VALID	0x1
Repeat the following actions the necessary number of times. That is, once for each valid defined block in the page.		
Read the process exit status.	ELM_LOCATION_STATUS_i[8] ECC_CORRECTABLE	
IF the process fails (too many errors): It is software dependent.	ELM_LOCATION_STATUS_i[8] ECC_CORRECTABLE	0x0
ELSE (process successful, the engine completes): Read the number of errors.	ELM_LOCATION_STATUS_i[8] ECC_CORRECTABLE	0x1
Read the error-location bit addresses for syndrome polynomial i of the ECC_NB_ERRORS first registers.	ELM_ERROR_LOCATION_0_i[12-0] ECC_ERROR_LOCATION	
	ELM_ERROR_LOCATION_1_i[12-0] ECC_ERROR_LOCATION	
	...	
	ELM_ERROR_LOCATION_15_i[12-0] ECC_ERROR_LOCATION	
ENDIF		
End Repeat		
Clear the ELM_IRQSTATUS register.	ELM_IRQSTATUS	0x1FF

Next page can be correctly processed after a page is fully processed, when all tagged polynomials have been processed (ELM_IRQSTATUS[i] LOC_VALID_i = 0x1 for all syndrome polynomials i used in the page).

13.3.2.4.2 Use Case: ELM Used in Continuous Mode

In this example, the ELM is programmed for an 8-bit error-correction capability in continuous mode (see [Table 13-216](#)). After reading a 528-byte NAND flash sector (512B data plus 16B spare area) with a 16-bit interface, a nonzero polynomial syndrome is reported from the GPMC (polynomial syndrome 0 is used in the ELM):

- $P = 0x0A16ABE115E44F767BFB0D0980$.

Table 13-216. Use Case: Continuous Mode

Step	Register/Bit Field/Programming Model	Value
Reset the module.	ELM_SYSCONFIG[1] SOFTRESET	0x1
Wait until reset is done.	ELM_SYSSTATUS[0] RESETDONE	0x1
Configure the slave interface power management: Smart idle is used.	ELM_SYSCONFIG[4-3] SIDLEMODE	0x2
Define the error-correction level used: 8 bits.	ELM_LOCATION_CONFIG[1-0] ECC_BCH_LEVEL	0x1
Define the maximum buffer length: 528 bytes ($2 \times 528 = 1056$).	ELM_LOCATION_CONFIG[26-16] ECC_SIZE	0x420
Set the ELM in continuous mode.	ELM_PAGE_CTRL	0
Enable interrupt for syndrome polynomial 0.	ELM_IRQENABLE[0] LOCATION_MASK_0	0x1
Set the input syndrome polynomial 0.	ELM_SYNDROME_FRAGMENT_0_i (where $i = 0$)	0xFB0D0980
	ELM_SYNDROME_FRAGMENT_1_i (where $i = 0$)	0xE44F767B
	ELM_SYNDROME_FRAGMENT_2_i (where $i = 0$)	0x16ABE115
	ELM_SYNDROME_FRAGMENT_3_i (where $i = 0$)	0x0000000A
Initiate the computation process.	ELM_SYNDROME_FRAGMENT_6_i[16] SYNDROME_VALID (where $i = 0$)	0x1
Wait until process is complete for syndrome polynomial 0: is generated or poll the status register.		

Table 13-216. Use Case: Continuous Mode (continued)

Step	Register/Bit Field/Programming Model	Value
Read that error-location process is complete for syndrome polynomial 0.	ELM_IRQSTATUS[0] LOC_VALID_0	0x1
Read the process exit status: All errors were successfully located.	ELM_LOCATION_STATUS_i[8] ECC_CORRECTABLE (where i = 0)	0x1
Read the number of errors: Four errors detected.	ELM_LOCATION_STATUS_i[4-0] ECC_NB_ERRORS (where i = 0)	0x4
Read the error-location bit addresses for syndrome polynomial 0 of the first four registers: Errors are located in the data buffer at decimal addresses 431, 1062, 1909, 3452.	ELM_ERROR_LOCATION_0_i (where i = 0)	0x1AF
	ELM_ERROR_LOCATION_1_i (where i = 0)	0x426
	ELM_ERROR_LOCATION_2_i (where i = 0)	0x775
	ELM_ERROR_LOCATION_3_i (where i = 0)	0xD7C
Clear the corresponding interrupt for polynomial 0.	ELM_IRQSTATUS[0] LOC_VALID_0	0x1

The NAND flash data in the sector are seen as a polynomial of degree 4223 (number of bits in a 528 byte buffer minus 1), with each data bit being a coefficient in the polynomial. When reading from a NAND flash using the GPMC module, computation of the polynomial syndrome assumes that the first NAND word read at address 0x0 contains the highest-order coefficient in the message. Furthermore, in the 16-bit NAND word, bits are ordered from bit 7 to bit 0, and then from bit 15 to bit 8. Based on this convention, an address table of the data buffer can be built. NAND memory addresses in [Table 13-217](#) are given in decimal format.

Table 13-217. 16-Bit NAND Sector Buffer Address Map

NAND Memory Address	Message Bit Addresses in Memory Word															
	15	14	13	12	11	10	9	8	7	6	5	4	3	2	1	0
0	4215	4214	4213	4212	4211	4210	4209	4208	4223	4222	4221	4220	4219	4218	4217	4216
1	4175	4174	4173	4172	4171	4170	4169	4168	4183	4182	4181	4180	4179	4178	4177	4176
...																
47	3463	3462	3461	3460	3459	3458	3457	3456	3471	3470	3469	3468	3467	3466	3465	3464
48	3447	3446	3445	3444	3443	3442	3441	3440	3455	3454	3453	3452	3451	3450	3449	3448
49	3431	3430	3429	3428	3427	3426	3425	3424	3439	3438	3437	3436	3435	3434	3433	3432
50	3415	3414	3413	3412	3411	3410	3409	3408	3423	3422	3421	3420	3419	3418	3417	3416
...																
255	135	134	133	132	131	130	129	128	143	142	141	140	139	138	137	136
256	119	118	117	116	115	114	113	112	127	126	125	124	123	122	121	120
257	103	102	101	100	99	98	97	96	111	110	109	108	107	106	105	104
258	87	86	85	84	83	82	81	80	95	94	93	92	91	90	89	88
259	71	70	69	68	67	66	65	64	79	78	77	76	75	74	73	72
260	55	54	53	52	51	50	49	48	63	62	61	60	59	58	57	56
261	39	38	37	36	35	34	33	32	47	46	45	44	43	42	41	40
262	23	22	21	20	19	18	17	16	31	30	29	28	27	26	25	24
263	7	6	5	4	3	2	1	0	15	14	13	12	11	10	9	8

The table can now be used to determine which bits in the buffer were incorrect and must be flipped. In this example, the first bit to be flipped is bit 4 from the 49th byte read from memory. It is up to the processor to correctly map this word to the copied buffer and flip this bit. The same process must be repeated for all detected errors.

13.3.2.4.3 Use Case: ELM Used in Page Mode

In this example, the ELM module is programmed for a 16-bit error-correction capability in page mode (see [Table 13-218](#)). After reading a 528-byte NAND flash sector (512B data plus 16B spare area) with a 16-bit interface,

four non-zero polynomial syndromes are reported from the GPMC (polynomial syndrome 0, 1, 2, and 3 are used in the ELM):

- P0 = 0xE8B0 12ADDB5A318E05BE B0693DB28330B5CC A329AA05E0B718EF
- P1 = 0xBAD0 49A0D932C22E6669 0948DF08BE093336 79C6BA10E5F935EB
- P2 = 0x69D9 B86ABCD5EC3697FA A6498FEE54556EA0 1579EF7D60BA3189
- P3 = 0x0

Table 13-218. Use Case: Page Mode

Step	Register/Bit Field/Programming Model	Value
Reset the module	ELM_SYSCONFIG[1] SOFTRESET	0x1
Wait until reset is done.	ELM_SYSSTATUS[0] RESETDONE	0x1
Configure the slave interface power management: Smart idle is used.	ELM_SYSCONFIG[4-3] SIDLEMODE	0x2
Define the error-correction level used: 16 bits	ELM_LOCATION_CONFIG[1-0] ECC_BCH_LEVEL	0x2
Define the maximum buffer length: 528 bytes	ELM_LOCATION_CONFIG[26-16] ECC_SIZE	0x420
Set the ELM in page mode (four blocks in a page)	ELM_PAGE_CTRL[0] SECTOR_0	0x1
	ELM_PAGE_CTRL[1] SECTOR_1	0x1
	ELM_PAGE_CTRL[2] SECTOR_2	0x1
	ELM_PAGE_CTRL[3] SECTOR_3	0x1
Disable all interrupts for syndrome polynomial and enable PAGE_MASK interrupt.	ELM_IRQENABLE	0x100
Set the input syndrome polynomial 0.	ELM_SYNDROME_FRAGMENT_0_i (where i = 0)	0xE0B718EF
	ELM_SYNDROME_FRAGMENT_1_i (where i = 0)	0xA329AA05
	ELM_SYNDROME_FRAGMENT_2_i (where i = 0)	0x8330B5CC
	ELM_SYNDROME_FRAGMENT_3_i (where i = 0)	0xB0693DB2
	ELM_SYNDROME_FRAGMENT_4_i (where i = 0)	0x318E05BE
	ELM_SYNDROME_FRAGMENT_5_i (where i = 0)	0x12ADDB5A
	ELM_SYNDROME_FRAGMENT_6_i (where i = 0)	0xE8B0
Set the input syndrome polynomial 1.	ELM_SYNDROME_FRAGMENT_0_i (where i = 1)	0xE5F935EB
	ELM_SYNDROME_FRAGMENT_1_i (where i = 1)	0x79C6BA10
	ELM_SYNDROME_FRAGMENT_2_i (where i = 1)	0xBE093336
	ELM_SYNDROME_FRAGMENT_3_i (where i = 1)	0x0948DF08
	ELM_SYNDROME_FRAGMENT_4_i (where i = 1)	0xC22E6669
	ELM_SYNDROME_FRAGMENT_5_i (where i = 1)	0x49A0D932
	ELM_SYNDROME_FRAGMENT_6_i (where i = 1)	0xBAD0
Set the input syndrome polynomial 2.	ELM_SYNDROME_FRAGMENT_0_i (where i = 2)	0x60BA3189
	ELM_SYNDROME_FRAGMENT_1_i (where i = 2)	0x1579EF7D
	ELM_SYNDROME_FRAGMENT_2_i (where i = 2)	0x54556EA0
	ELM_SYNDROME_FRAGMENT_3_i (where i = 2)	0xA6498FEE
	ELM_SYNDROME_FRAGMENT_4_i (where i = 2)	0xEC3697FA
	ELM_SYNDROME_FRAGMENT_5_i (where i = 2)	0xB86ABCD5
	ELM_SYNDROME_FRAGMENT_6_i (where i = 2)	0x69D9
Set the input syndrome polynomial 3.	ELM_SYNDROME_FRAGMENT_0_i (where i = 3)	0x0
	ELM_SYNDROME_FRAGMENT_1_i (where i = 3)	0x0
	ELM_SYNDROME_FRAGMENT_2_i (where i = 3)	0x0
	ELM_SYNDROME_FRAGMENT_3_i (where i = 3)	0x0
	ELM_SYNDROME_FRAGMENT_4_i (where i = 3)	0x0
	ELM_SYNDROME_FRAGMENT_5_i (where i = 3)	0x0
	ELM_SYNDROME_FRAGMENT_6_i (where i = 3)	0x0

Table 13-218. Use Case: Page Mode (continued)

Step	Register/Bit Field/Programming Model	Value
Initiate the computation process for syndrome polynomial 0	ELM_SYNDROME_FRAGMENT_6_i[16] SYNDROME_VALID (where i = 0)	0x1
Initiate the computation process for syndrome polynomial 1	ELM_SYNDROME_FRAGMENT_6_i[16] SYNDROME_VALID (where i = 1)	0x1
Initiate the computation process for syndrome polynomial 2	ELM_SYNDROME_FRAGMENT_6_i[16] SYNDROME_VALID (where i = 2)	0x1
Initiate the computation process for syndrome polynomial 3	ELM_SYNDROME_FRAGMENT_6_i[16] SYNDROME_VALID (where i = 3)	0x1
Wait until process is complete for syndrome polynomial 0, 1, 2, and 3: Wait until the interrupt is generated or poll the status register.		
Wait for page completed interrupt: All error locations are valid.	ELM_IRQSTATUS[8] PAGE_VALID	0x1
Read the process exit status for syndrome polynomial 0: All errors were successfully located.	ELM_LOCATION_STATUS_i[8] ECC_CORRECTABLE (where i = 0)	0x1
Read the process exit status for syndrome polynomial 1: All errors were successfully located.	ELM_LOCATION_STATUS_i[8] ECC_CORRECTABLE (where i = 1)	0x1
Read the process exit status for syndrome polynomial 2: All errors were successfully located.	ELM_LOCATION_STATUS_i[8] ECC_CORRECTABLE (where i = 2)	0x1
Read the process exit status for syndrome polynomial 3: All errors were successfully located.	ELM_LOCATION_STATUS_i[8] ECC_CORRECTABLE (where i = 3)	0x1
Read the number of errors for syndrome polynomial 0: four errors detected.	ELM_LOCATION_STATUS_i[4-0] ECC_NB_ERRORS (where i = 0)	0x4
Read the number of errors for syndrome polynomial 1: two errors detected.	ELM_LOCATION_STATUS_i[4-0] ECC_NB_ERRORS (where i = 1)	0x2
Read the number of errors for syndrome polynomial 2: one error detected.	ELM_LOCATION_STATUS_i[4-0] ECC_NB_ERRORS (where i = 2)	0x1
Read the number of errors for syndrome polynomial 3: no errors detected.	ELM_LOCATION_STATUS_i[4-0] ECC_NB_ERRORS (where i = 3)	0x0
Read the error-location bit addresses for syndrome polynomial 0 of the first four registers:	ELM_ERROR_LOCATION_0_i (where i = 0)	0x1FE
	ELM_ERROR_LOCATION_1_i (where i = 0)	0x617
	ELM_ERROR_LOCATION_2_i (where i = 0)	0x650
	ELM_ERROR_LOCATION_3_i (where i = 0)	0xA83
Read the error-location bit addresses for syndrome polynomial 1 of the first two registers:	ELM_ERROR_LOCATION_0_i (where i = 1)	0x4
	ELM_ERROR_LOCATION_1_i (where i = 1)	0x1036
Read the errors location bit addresses for syndrome polynomial 2 of the first registers:	ELM_ERROR_LOCATION_0_i (where i = 1)	0x3E8
Clear the ELM_IRQSTATUS register.	ELM_IRQSTATUS	0x1FF

13.3.3 Multimedia Card (MMC)

This chapter describes the MMC of the device.

13.3.3.1 Introduction	1281
13.3.3.2 Integration	1282
13.3.3.3 Functional Description	1289
13.3.3.4 Low-Level Programming Models	1321

13.3.3.1 Introduction

13.3.3.1.1 MMCS D Features

The general features of the MMCS D host controller IP are:

- Built-in 1024-byte buffer for read or write
- Two DMA channels, one interrupt line
- Clock support
 - 96-MHz functional clock source input
 - up to 384Mbit/sec (48MByte/sec) in MMC mode 8-bit data transfer
 - up to 192Mbit/sec (24MByte/sec) in High-Speed SD mode 4-bit data transfer
 - up to 24Mbit/sec (3MByte/sec) in Default SD mode 1-bit data transfer
- Support for SDA 3.0 Part A2 programming model
- Serial link supports full compliance with:
 - MMC command/response sets as defined in the MMC standard specification v4.3.
 - SD command/response sets as defined in the SD Physical Layer specification v2.00
 - SDIO command/response sets and interrupt/read-wait suspend-resume operations as defined in the SD part E1 specification v 2.00
 - SD Host Controller Standard Specification sets as defined in the SD card specification Part A2 v2.00

13.3.3.1.2 Unsupported MMCS D Features

The MMCS D module features not supported in this device are shown in [Table 13-219](#).

Table 13-219. Unsupported MMCS D Features

Feature	Reason
MMC Out-of-band interrupts	MMC_OBI input tied low
Master DMA operation	Disabled through synthesis parameter
Card Supply Control (MMCS D(1-2))	Signal not pinned out
Dual Data Rate (DDR) mode	Timing not supported

13.3.3.2 Integration

This device contains one instance of the Multimedia Card (MMC), Secure Digital (SD), and Secure Digital I/O (SDIO) high speed interface module (MMCSD). The controller provides an interface to an MMC, SD memory card or SDIO card.

The application interface is responsible for managing transaction semantics; the MMC/SDIO host controller deals with MMC/SDIO protocol at transmission level, packing data, adding CRC, start/end bit and checking for syntactical correctness. Figure 13-178 through Figure 13-180 below show examples of systems using the MMCSD controller.

ADVANCE INFORMATION

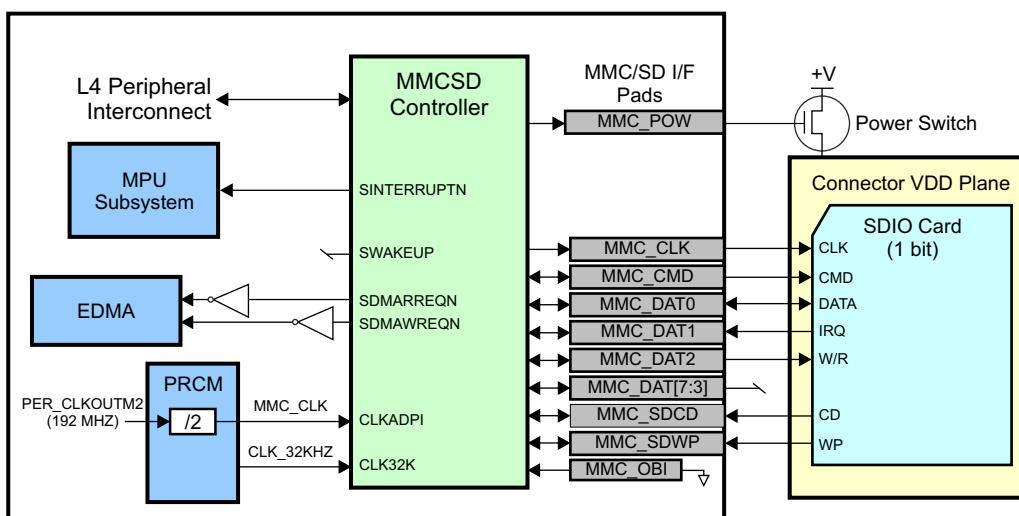

Figure 13-178. MMCSD Module SDIO Application

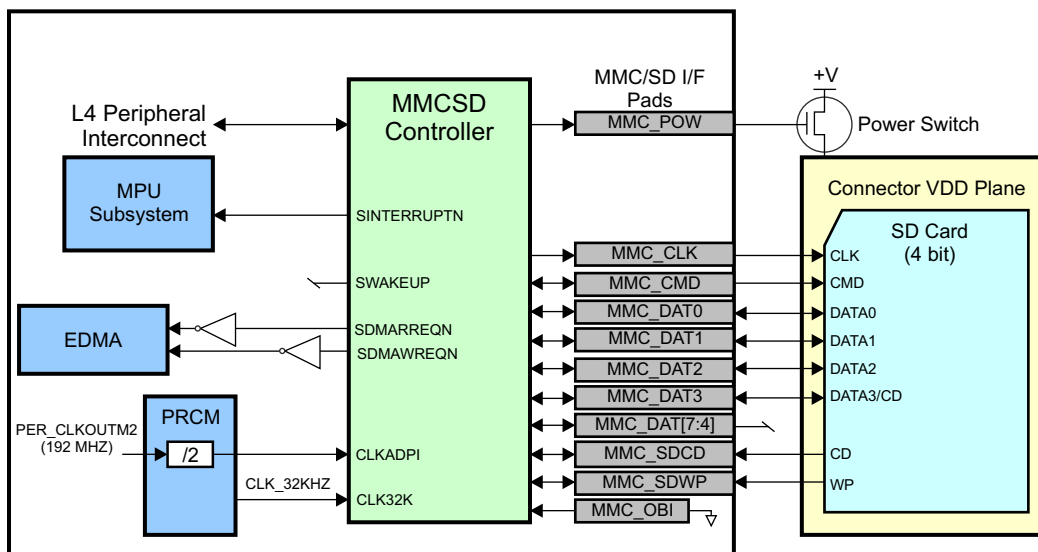

Figure 13-179. MMCSD (4-bit) Card Application

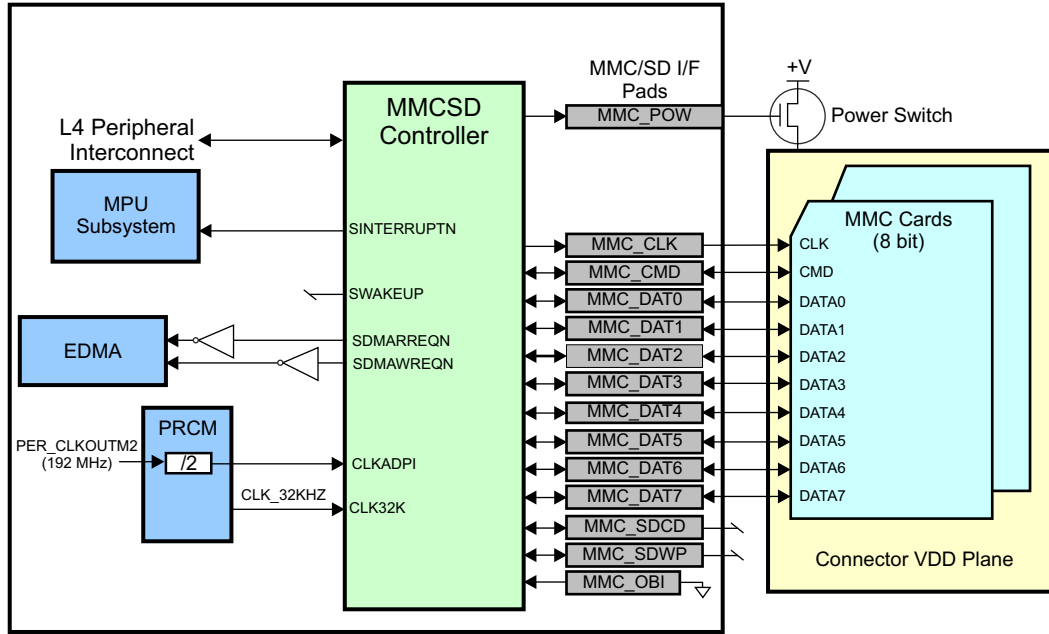

Figure 13-180. MMCS Module MMC Application

ADVANCE INFORMATION

13.3.3.2.1 MMCSD Integration

There is 1x MMCSD integrated in the device. The diagram below provides a visual representation of the device integration details.

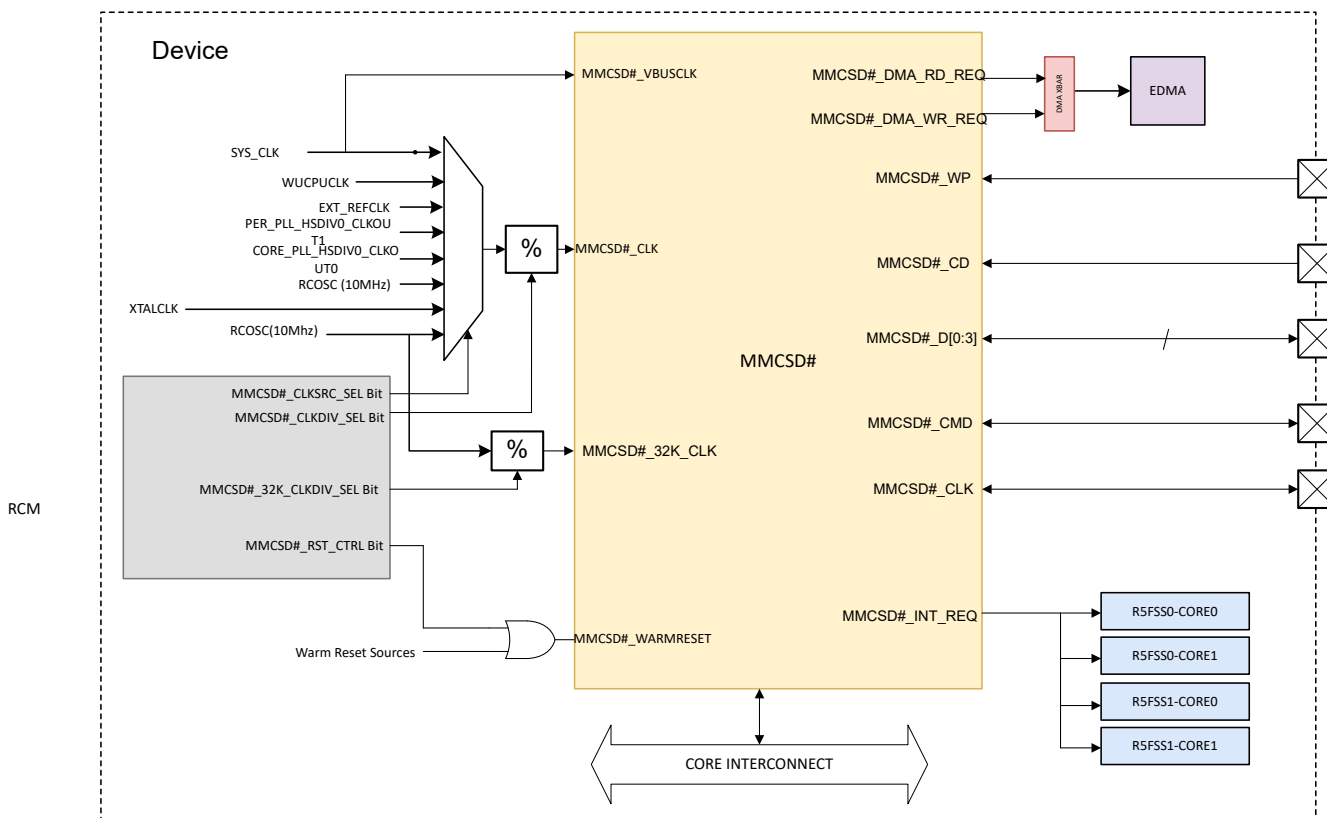

Figure 13-181. MMCSD Integration

The tables below summarize the device integration details of MMCSD.

Table 13-220. MMCSD Device Integration

This table describes the module integration details.

MMCSD Instance	Device Allocation	SoC Interconnect
MMCSD0	✓	CORE VBUSM Interconnect

Table 13-221. MMCSD Clocks

This table describes the module clocking signals.

MMCSD Instance	MMCSD Clock Input	Source Clock Signal	Source	Default Freq	Description	
MMCSD0	MMCSD0_ICLK (VBUSP_CLK)	SYS_CLK	PLL_CORE_CLK: HSDIV0_CLKOUT0	200 MHz	MMCSD0 Interface Clock	
	MMCSD0_32K_CLK	MMCSD0_32K_CLK	XTALCLK	32 KHz	MMCSD0 Debounce Clock	
	MMCSD0_FCLK (MMCSD_CLK)	XTALCLK	External XTAL	External XTAL	25 MHz	MMCSD0 Interface Clock
			EXT_REFCLK	External Reference Clock (EXT_REFCLK)	100 MHz	
		SYS_CLK	PLL_CORE_CLK: HSDIV0_CLKOUT0	200 MHz		
		DPLL_PER_HSDIV0_CLK OUT1	PLL_PER_CLK: HSDIV0_CLKOUT1	192 MHz		
		DPLL_CORE_HSDIV0_CLK KOUT0	PLL_CORE_CLK: HSDIV0_CLKOUT0	400 MHz		
		RCCLK10M	Internal 10 MHz RC Oscillator (RCCLK10M)	10 MHz		
		XTALCLK	External XTAL	25 MHz		
RCCLK10M	Internal 10 MHz RC Oscillator (RCCLK10M)	10 MHz				

Table 13-222. MMCSD Resets

This table describes the module reset signals.

MMCSD Instance	MMCSD Reset Input	Source Reset Signal	Source	Description
MMCSD0	MMCSD0_RST	Warm Reset (MOD_G_RST)	RCM + Warm Reset Sources	MMCSD0 Asynchronous Reset

Table 13-223. MMCSD Interrupt Requests

This table describes the module interrupt requests.

MMCSD Instance	MMCSD Interrupt Signal	Destination Interrupt Input	Destination	Type	Description
MMCSD0	MMCSD0_INT_req_0	MMCSD0_INT_req_0	ALL R5FSS Cores	Level	MMCSD0 Interrupt

Table 13-224. MMCSD DMA Requests

This table describes the module DMA requests.

MMCSD Instance	MMCSD DMA Event	Destination DMA Event Input	Destination	Type	Description
MMCSD0	MMCSD0_DMA_RD_REQ	MMCSD0_DMA_RD_REQ	EDMA Crossbar (DMA_XBAR)	Level	MMCSD0 DMA Read Request
	MMCSD0_DMA_WR_REQ	MMCSD0_DMA_WR_REQ			MMCSD0 DMA Write Request

Note

For more information on the interconnects, see the *System Interconnect* chapter.

For more information on power, reset, and clock management, see the corresponding sections within the *Device Configuration* chapter.

For more information on the device interrupt controllers, see the *Interrupt Controllers* chapter.

13.3.3.2.2 MMCSDB Connectivity Attributes

The general connectivity attributes for the three MMCSDB modules are shown in [Table 13-225](#).

Table 13-225. MMCSDB Connectivity Attributes

Attributes	Type
Power Domain	Peripheral Domain
Clock Domain	PD_PER_L4LS_GCLK (OCP) PD_PER_MMCFCLK (Func) CLK_32KHZ (Debounce)
Reset Signals	PER_DOM_RST_N
Idle/Wakeup Signals	Smart Idle
Interrupt Requests	1 interrupt per instance to MPU Subsystem (MMCSDBINT)
DMA Requests	2 DMA requests per instance to EDMA (SDTXEVTx, SDRXEVTx) (Active low, need to be inverted in glue logic)
Physical Address	L4 Peripheral slave port

13.3.3.2.3 MMCSD Clock and Reset Management

The MMCSD controller has separate bus interface and functional clocks. The debounce clock is created by dividing the 48-MHz (24 MHz @ OPP50) clock in the PRCM by two and then dividing the resulting 24-MHz (12 MHz @ OPP50) clock by a fixed 732.4219 (366.2109 @ OPP50) in the Control Module to get a 32-kHz clock. This clock is fed back into the PRCM for clock gating. (See the CTRL_CLK32KDIVRATIO register in *Control Module* for more details).

Table 13-226. MMCSD Clock Signals

Clock Signal	Max Freq	Reference / Source	Comments
CLK Interface clock	100 MHz	CORE_CLKOUTM4 / 2	pd_per_i4ls_gclk from PRCM
CLKADPI Functional clock	96 MHz	PER_CLKOUTM2 / 2	pd_per_mmc_fclk from PRCM
CLK32 Input de-bounce clock	32.768 KHz	CLK_24 / 732.4219	clk_32KHz from PRCM

Note

Maximum MMC_CLK signal frequency is 48 MHz.

13.3.3.2.4 MMCSD Pin List

The MMCSD interface pins are summarized in [Table 13-227](#).

Table 13-227. MMCSD Pin List

Pin	Type	Description
MMCx_CLK	I/O ⁽¹⁾	MMC/SD serial clock output
MMCx_CMD	I/O	MMC/SD command signal
MMCx_DAT0	I/O	MMC/SD data signal
MMCx_DAT1	I/O	MMC/SD data signal, SDIO interrupt input
MMCx_DAT2	I/O	MMC/SD data signal, SDIO read wait output
MMCx_DAT[7:3]	I/O	MMC/SD data signals
MMCx_POW	O	MMC/SD power supply control (MMCSD0 only)
MMCx_SDCD	I	SD card detect (from connector)
MMCx_SDWP	I	SD write protect (from connector)
MMCx_OBI	I	MMC out of band interrupt

- (1) These signals are also used as inputs to re-time or sync data. The associated CONF_<module>_pin_RXACTIVE bit for these signals must be set to 1 to enable the inputs back to the module. It is also recommended to place a 33-ohm resistor in series (close to the processor) on each of these signals to avoid signal reflections.

The direction of the data lines depends on the selected data transfer mode as summarized in [Table 13-228](#).

Table 13-228. DAT Line Direction for Data Transfer Modes

	MMC/SD 1-bit mode	MMC/SD 4-bit mode	MMC/SD 8-bit mode	SDIO 1-bit mode	SDIO 4-bit mode
DAT[0]	I/O	I/O	I/O	I/O	I/O
DAT[1]	I ⁽¹⁾	I/O	I/O	I ⁽²⁾	I/O or I ⁽²⁾
DAT[2]	I ⁽¹⁾	I/O	I/O	I/O ⁽³⁾	I/O or O ⁽³⁾
DAT[3]	I ⁽¹⁾	I/O	I/O	I ⁽¹⁾	I/O
DAT[4]	I ⁽¹⁾	I ⁽¹⁾	I/O	I ⁽¹⁾	I ⁽¹⁾
DAT[5]	I ⁽¹⁾	I ⁽¹⁾	I/O	I ⁽¹⁾	I ⁽¹⁾
DAT[6]	I ⁽¹⁾	I ⁽¹⁾	I/O	I ⁽¹⁾	I ⁽¹⁾

Table 13-228. DAT Line Direction for Data Transfer Modes (continued)

	MMC/SD 1-bit mode	MMC/SD 4-bit mode	MMC/SD 8-bit mode	SDIO 1-bit mode	SDIO 4-bit mode
DAT[7]	I ⁽¹⁾	I ⁽¹⁾	I/O	I ⁽¹⁾	I ⁽¹⁾

- (1) Hi-Z state to avoid bus conflict.
- (2) To support incoming interrupt from the SDIO card.
- (3) To support read wait to the SDIO card. By default it is Input, Output only in read wait period.

The direction of the MMCSD data buffers are controlled by ADPDATDIROQ signals. ADPDATDIROQ[i] = 1 sets the corresponding DAT signal(s) in read position (input) and ADPDATDIROQ[i] = 0 sets the corresponding DAT signal(s) in write position (output). Additionally, the ADPDATDIRLS signals are provided (with opposite polarity) to control the direction of external level shifters. The value of these control signals for the various data modes are summarized in [Table 13-229](#).

Table 13-229. ADPDATDIROQ and ADPDATDIRLS Signal States

	MMC/SD 1-bit mode	MMC/SD 4-bit mode	MMC/SD 8-bit mode	SDIO 1-bit mode	SDIO 4-bit mode
DAT[0]	ADPDATDIRLS[0] = 0 / 1 ADPDATDIROQ[0] = 1 / 0	ADPDATDIRLS[0] = 0 / 1 ADPDATDIROQ[0] = 1 / 0	ADPDATDIRLS[0] = 0 / 1 ADPDATDIROQ[0] = 1 / 0	ADPDATDIRLS[0] = 0 / 1	ADPDATDIRLS[0] = 0 / 1 ADPDATDIROQ[0] = 1 / 0
DAT[2]	ADPDATDIRLS[2] = 0 ADPDATDIROQ[2] = 1	ADPDATDIRLS[2] = 0 / 1 ADPDATDIROQ[2] = 1 / 0	ADPDATDIRLS[2] = 0 / 1 ADPDATDIROQ[2] = 1 / 0	ADPDATDIRLS[2] = 0 / 1 ADPDATDIROQ[2] = 1 / 0	ADPDATDIRLS[2] = 0 / 1 ADPDATDIROQ[2] = 1 / 0
DAT[1] DAT[3]	ADPDATDIRLS[1] = 0 ADPDATDIROQ[1] = 1	ADPDATDIRLS[1] = 0 / 1 ADPDATDIROQ[1] = 1 / 0	ADPDATDIRLS[1] = 0 / 1 ADPDATDIROQ[1] = 1 / 0	ADPDATDIRLS[1] = 0 ADPDATDIROQ[1] = 1	ADPDATDIRLS[1] = 0 / 1 ADPDATDIROQ[1] = 1 / 0
DAT[4] DAT[5] DAT[6] DAT[7]	ADPDATDIRLS[3] = 0 ADPDATDIROQ[3] = 1	ADPDATDIRLS[3] = 0 ADPDATDIROQ[3] = 1	ADPDATDIRLS[3] = 0 / 1 ADPDATDIROQ[3] = 1 / 0	ADPDATDIRLS[3] = 0 ADPDATDIROQ[3] = 1	ADPDATDIRLS[3] = 0 ADPDATDIROQ[3] = 1

ADPDATIRLSx = 0 for input and 1 for output — these signals are not pinned out on this device.

ADPDATIROQx = 1 for output and 0 for input.

Grayed cells indicate that the data line is not used in the selected transfer mode.

13.3.3.3 Functional Description

One MMC/SD/SDIO host controller can support one MMC memory card, one SD card, or one SDIO card.

Other combinations (for example, two SD cards, one MMC card, and one SD card) are not supported through a single controller.

13.3.3.3.1 MMC/SD/SDIO Functional Modes

13.3.3.3.1.1 MMC/SD/SDIO Connected to an MMC, an SD Card, or an SDIO Card

Figure 13-182 shows the MMC/SD/SDIO1 and MMC/SD/SDIO2 host controllers connected to an MMC, an SD, or an SDIO card and its related external connections.

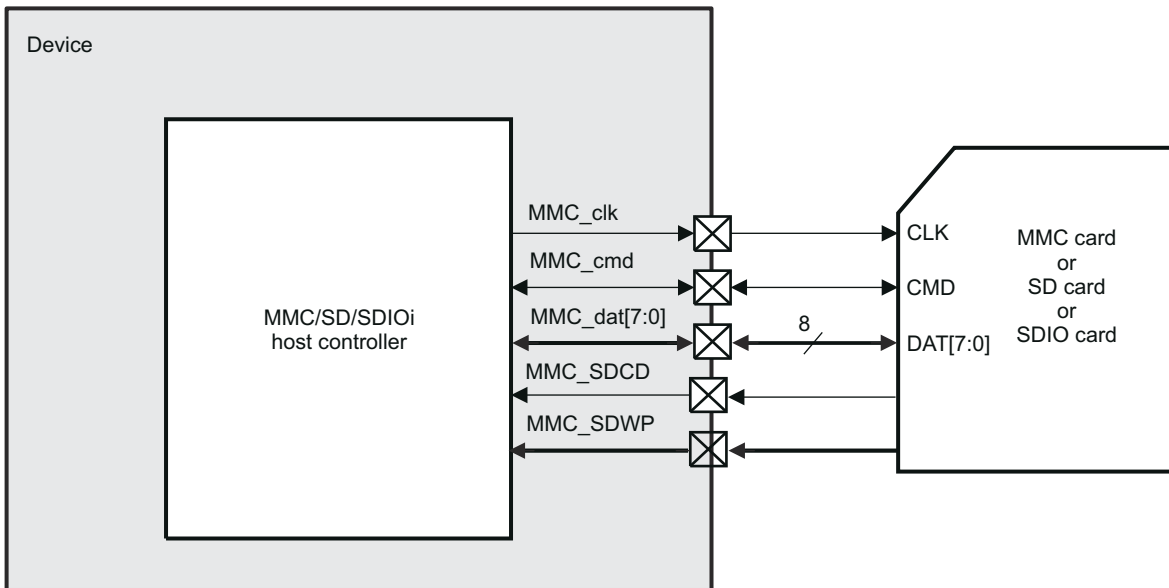

Figure 13-182. MMC/SD1/2 Connectivity to an MMC/SD Card

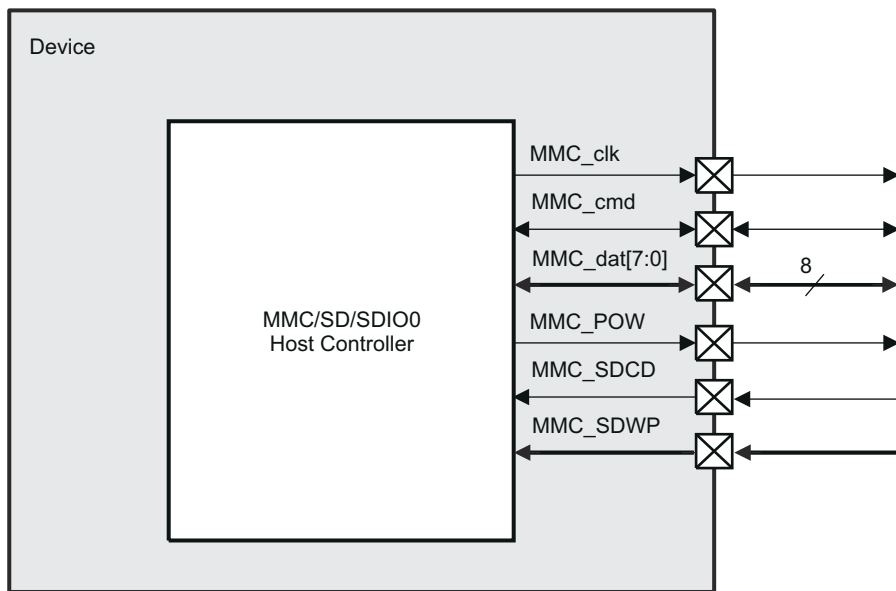

Figure 13-183. MMC/SD0 Connectivity to an MMC/SD Card

ADVANCE INFORMATION

Figure 13-183 shows the MMC/SD/SDIO0 host controller connected to an MMC, SD, or SDIO card and its related external connections. Note that MMC/SD/SDIO0 uses the same signals as MMC/SD/SDIO1 and 2 but adds MMC_POW.

The following MMC/SD/SDIO controller pins are used

- **MMC_CMD** This pin is used for two-way communication between the connected card and the MMC/SD/SDIO controller. The MMC/SD/SDIO controller transmits commands to the card and the memory card drives responses to the commands on this pin.
- **MMC_DAT7-0** Depending on which type of card you are using, you may need to connect 1, 4, or 8 data lines. The number of DAT pins (the data bus width) is set by the Data Transfer Width (DTW) bit in the MMC control register (SD_HCTL). For more information, see , *MMCS D Registers*.
- **MMC_CLK** This pin provides the clock to the memory card from the MMC/SD controller.
- **MMC_POW** Used for MMC/SD card's cards on/off power supply control. When high, denotes power-on condition.
- **MMC_SDCCD** This input pin serves as the MMC/SD/SDIO card detect. This signal is received from a mechanical switch on the slot.
- **MMC_SDWP** This input pin is used for the SD/SDIO card's write protect. This signal is received from a mechanical protect switch on the slot (system dependant). Applicable only for SD and SDIO cards that have a mechanical sliding tablet on the side of the card.

Note: The MMC_CLK pin functions as an output but must be configured as an I/O to internally loopback the clock to time the inputs.

Table 13-230 provides a summary of these pins.

Table 13-230. MMC/SD/SDIO Controller Pins and Descriptions

Pin	Type	1-Bit Mode	4-Bit Mode	8-Bit Mode	Reset Value
MMC_CLK ⁽¹⁾	O	Clock Line	Clock Line	Clock Line	High impedance
MMC_CMD	I/O	Command Line	Command Line	Command Line	High impedance
MMC_DAT0	I/O	Data Line 0	Data Line 0	Data Line 0	0
MMC_DAT1	I/O	(not used)	Data Line 1	Data Line 1	0
MMC_DAT2	I/O	(not used)	Data Line 2	Data Line 2	0
MMC_DAT3	I/O	(not used)	Data Line 3	Data Line 3	0
MMC_DAT4	I/O	(not used)	(not used)	Data Line 4	0
MMC_DAT5	I/O	(not used)	(not used)	Data Line 5	0
MMC_DAT6	I/O	(not used)	(not used)	Data Line 6	0
MMC_DAT7	I/O	(not used)	(not used)	Data Line 7	0

(1) The MMC_CLK pin functions as an output but must be configured as an I/O to internally loopback the clock to time the inputs.

13.3.3.3.1.2 Protocol and Data Format

The bus protocol between the MMC/SD/SDIO host controller and the card is message-based. Each message is represented by one of the following parts:

Command: A command starts an operation. The command is transferred serially from the \MMC/SD/SDIO host controller to the card on the mmc_cmd line.

Response: A response is an answer to a command. The response is sent from the card to the MMC/SD/SDIO host controller. It is transferred serially on the mmc_cmd line.

Data: Data are transferred from the MMC/SD/SDIO host controller to the card or from a card to the MMC/SD/SDIO host controller using the DATA lines.

Busy: The mmc_dat0 signal is maintained low by the card as far as it is programming the data received.

CRC status: CRC result is sent by the card through the mmc_dat0 line when executing a write transfer. In the case of transmission error, occurring on any of the active data lines, the card sends a negative CRC status on

mmc_dat0. In the case of successful transmission, over all active data lines, the card sends a positive CRC status on mmc_dat0 and starts the data programming procedure.

13.3.3.3.1.2.1 Protocol

There are two types of data transfer:

- Sequential operation
- Block-oriented operation

There are specific commands for each type of operation (sequential or block-oriented). See the *Multimedia Card System Specification*, the *SD Memory Card Specifications*, and the *SDIO Card Specification, Part E1* for details about commands and programming sequences supported by the MMC, SD, and SDIO cards.

CAUTION
Stream commands are supported only by MMC cards.

Figure 13-184 and Figure 13-185 show how sequential operations are defined. Sequential operation is only for 1-bit transfer and initiates a continuous data stream. The transfer terminates when a stop command follows on the mmc_cmd line.

ADVANCE INFORMATION

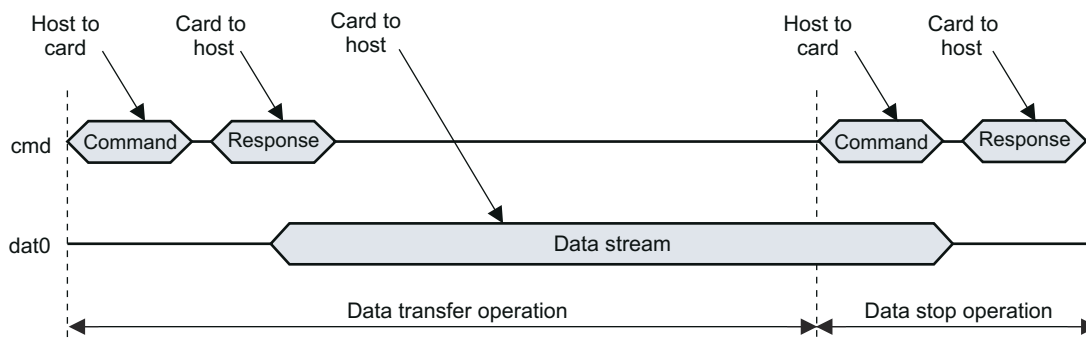

Figure 13-184. Sequential Read Operation (MMC Cards Only)

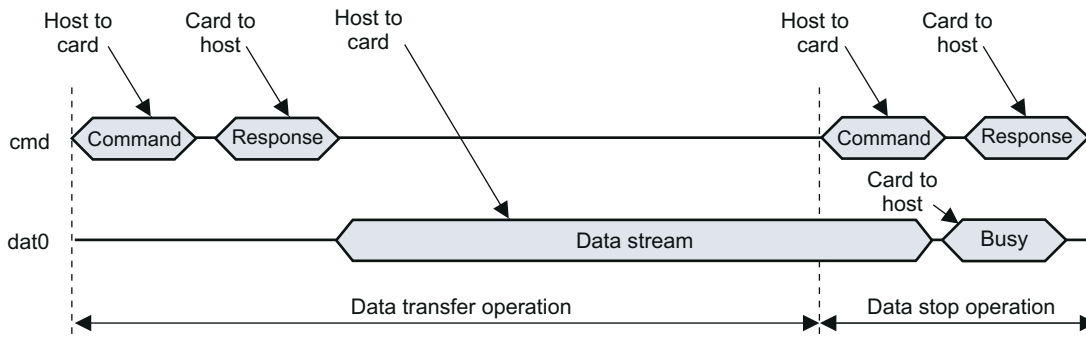

Figure 13-185. Sequential Write Operation (MMC Cards Only)

Figure 13-186 and Figure 13-187 show how multiple block-oriented operations are defined. A multiple block-oriented operation sends a data block plus CRC bits. The transfer terminates when a stop command follows on the mmc_cmd line. These operations are available for all kinds of cards.

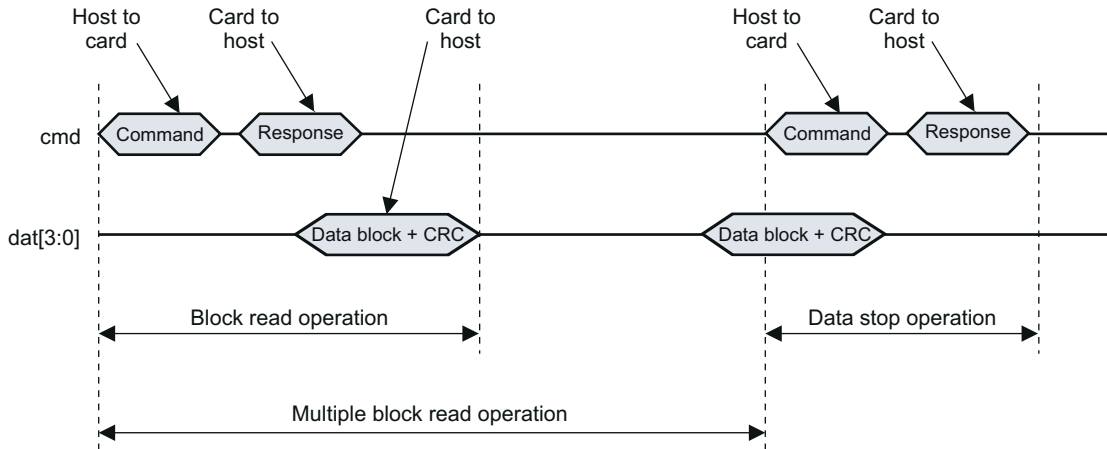

Figure 13-186. Multiple Block Read Operation (MMC Cards Only)

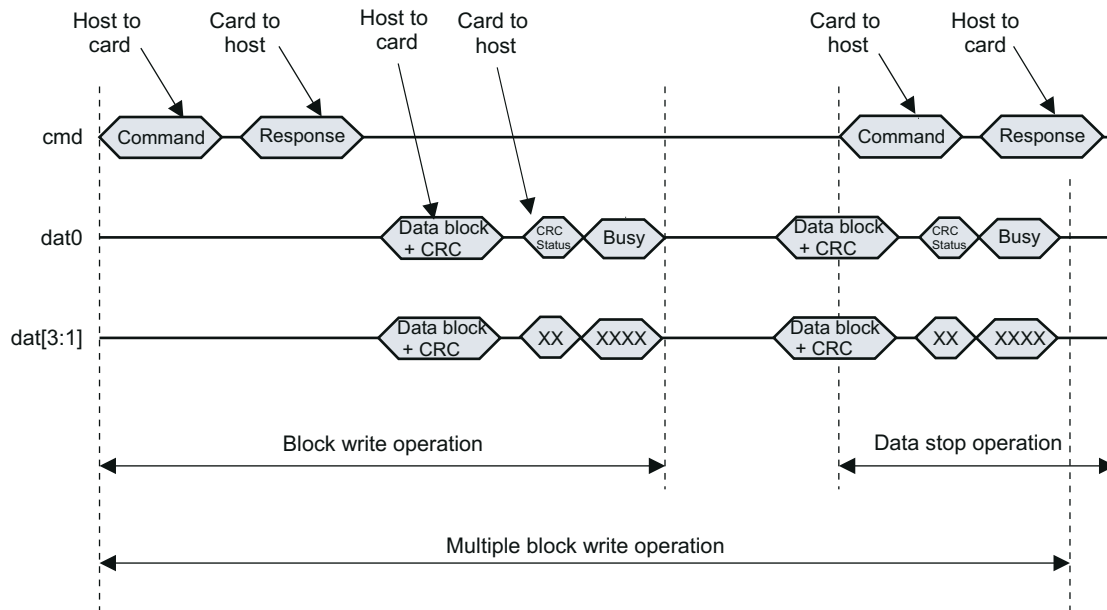

Figure 13-187. Multiple Block Write Operation (MMC Cards Only)

Note

1. The card busy signal is not always generated by the card; the previous examples show a particular case.
2. It is the software's responsibility to do a software reset after a data timeout to ensure that mmc_clk is stopped. The software reset is done by setting bit 26 in the SD_SYSCTL register to 1.
3. For multiblock transfer, and especially for MMC cards, you can abort a transfer without using a stop command. Use a CMD23 before a data transfer to define the number of blocks that will be transferred, then the transfer stops automatically after the last block (provided the MMC card supports this feature).

13.3.3.1.2.2 Data Format

Coding Scheme for Command Token

Command packets always start with 0 and end with 1. The second bit is a transmitter bit1 for a host command. The content is the command index (coded by 6 bits) and an argument (for example, an address), coded by 32 bits. The content is protected by 7-bit CRC checksum (see [Figure 13-188](#)).

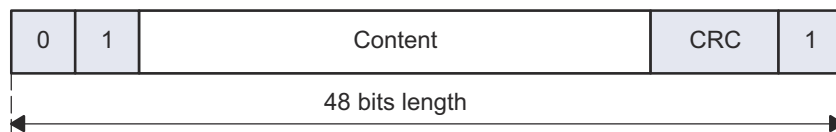

Figure 13-188. Command Token Format

Coding Scheme for Response Token

Response packets always start with 0 and end with a 1. The second bit is a transmitter bit0 for a card response. The content is different for each type of response (R1, R2, R3, R4, R5, and R6) and the content is protected by 7-bit CRC checksum. Depending on the type of commands sent to the card, the SD_CMD register must be configured differently to avoid false CRC or index errors to be flagged on command response (see [Table 13-231](#)). For more details about response types, see the *Multimedia Card System Specification*, the *SD Memory Card Specification*, or the *SDIO Card Specification*.

Table 13-231. Response Type Summary

Response Type SD_CMD[17:16] RSP_TYPE ⁽¹⁾	Index Check Enable SD_CMD[20] CICE	CRC Check Enable SD_CMD[19] CCCE	Name of Response Type
00	0	0	No Response
01	0	1	R2
10	0	0	R3 (R4 for SD cards)
10	1	1	R1, R6, R5 (R7 for SD cards)
11	1	1	R1b, R5b

(1) The MMC/SD/SDIO host controller assumes that both clocks may be switched off, whatever the value set in the SD_SYSCONFIG[9:8] CLOCKACTIVITY bit.

[Figure 13-189](#) and [Figure 13-190](#) depict the 48-bit and 136-bit response packets.

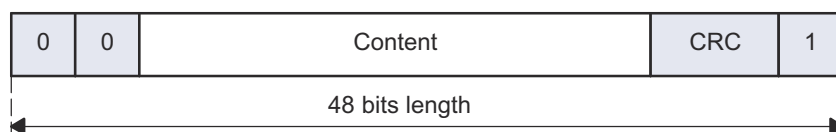

Figure 13-189. 48-Bit Response Packet (R1, R3, R4, R5, R6)

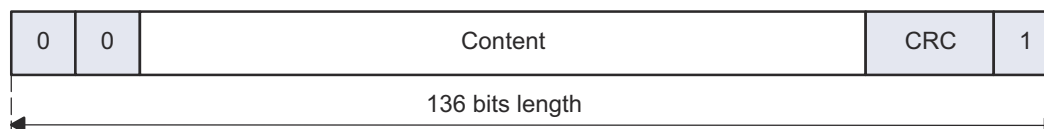

Figure 13-190. 136-Bit Response Packet (R2)

Coding Scheme for Data Token

Data tokens always start with 0 and end with 1 (see [Figure 13-191](#), [Figure 13-192](#), [Figure 13-193](#), and [Figure 13-194](#)).

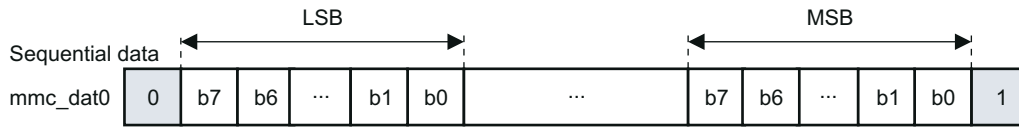

Figure 13-191. Data Packet for Sequential Transfer (1-Bit)

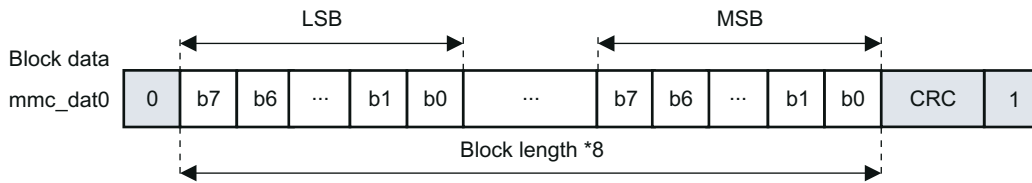

Figure 13-192. Data Packet for Block Transfer (1-Bit)

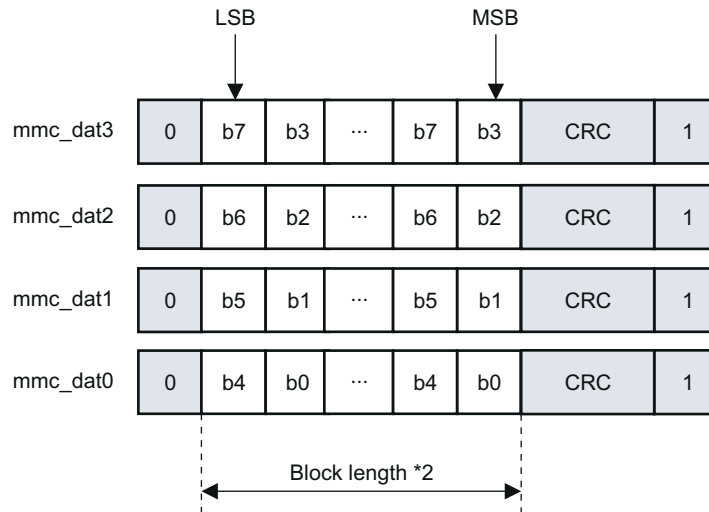

Figure 13-193. Data Packet for Block Transfer (4-Bit)

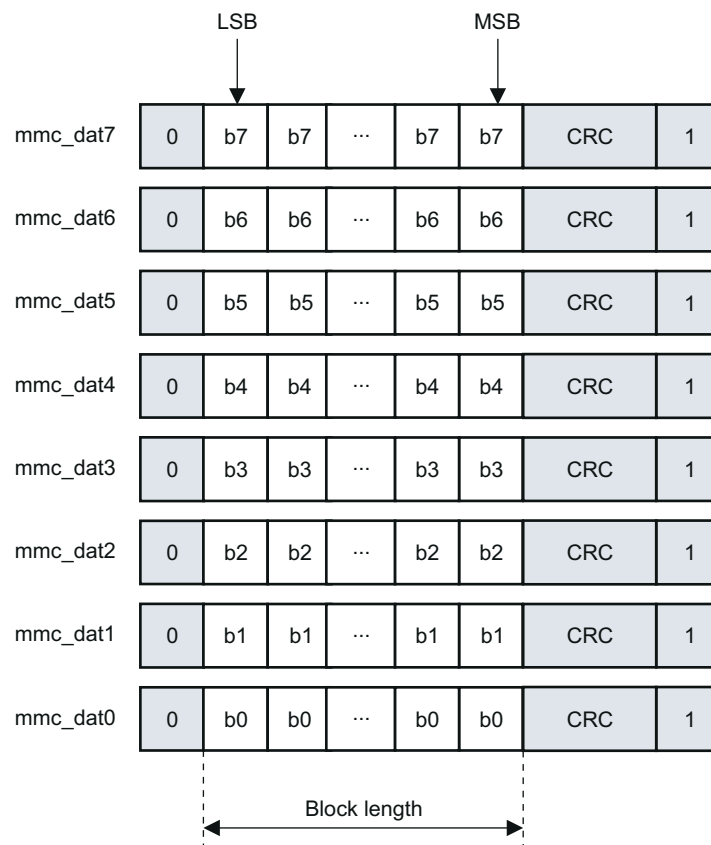

Figure 13-194. Data Packet for Block Transfer (8-Bit)

13.3.3.3.2 Resets

13.3.3.3.2.1 Hardware Reset

The module is reinitialized by the hardware.

The SD_SYSSTS[0] RESETDONE bit can be monitored by the software to check if the module is ready-to-use after a hardware reset.

This hardware reset signal has a global reset action on the module. All configuration registers and all state machines are reset in all clock domains.

This hardware reset signal has a global reset action on the module. All configuration registers and all state-machines are reset in all clock domains.

13.3.3.3.2.2 Software Reset

The module is reinitialized by software through the SD_SYSCONFIG[1] SOFTRESET bit. This bit has the same action on the module logic as the hardware signal except for:

- Debounce logic
- SD_PSTATE, SD_CAPA, and SD_CUR_CAPA registers (see corresponding register descriptions)

The SOFTRESET bit is active high. The bit is automatically reinitialized to 0 by the hardware. The SD_SYSCTL[24] SRA bit has the same action as the SOFTRESET bit on the design.

The SD_SYSSTS[0] RESETDONE bit can be monitored by the software to check if the module is ready-to-use after a software reset.

Moreover, two partial software reset bits are provided:

- SD_SYSCTL[26] SRD bit

- SD_SYSCTL[25] SRC bit

These two reset bits are useful to reinitialize data or command processes respectively in case of line conflict. When set to 1, a reset process is automatically released when the reset completes:

- The SD_SYSCTL[26] SRD bit resets all finite state-machines and status management that handle data transfers on both the interface and functional side.
- The SD_SYSCTL[25] SRC bit resets all finite state-machines and status management that handle command transfers on both the interface and functional side.

Note

If **any** of the clock inputs are not present for the MMC/SD/SDIO peripheral, the software reset will not complete.

13.3.3.3.3 Power Management

The MMC/SD/SDIO host controller can enter into different modes and save power:

- Normal mode
- Idle mode

The two modes are mutually exclusive (the module can be in normal mode or in idle mode). The MMC/SD/SDIO host controller is compliant with the PRCM module handshake protocol. When the MMC/SD/SDIO power domain is off, the only way to wake up the power domain and different MMC/SD/SDIO clocks is to monitor the mmc_dat1 input pin state via a different GPIO line for each MMC/SD/SDIO interface.

13.3.3.3.3.1 Normal Mode

The autogating of interface and functional clocks occurs when the following conditions are met:

- The SD_SYSCONFIG[0] AUTOIDLE bit is set to 1.
- There is no transaction on the MMC interface.

The autogating of interface and functional clocks stops when the following conditions are met:

- A register access occurs through the L3 (or L4) interconnect.
- A wake-up event occurs (an interrupt from a SDIO card).
- A transaction on the MMC/SD/SDIO interface starts.

Then the MMC/SD/SDIO host controller enters in low-power state even if SD_SYSCONFIG[0] AUTOIDLE is cleared to 0. The functional clock is internally switched off and only interconnect read and write accesses are allowed.

13.3.3.3.3.2 Idle Mode

The clocks provided to MMC/SD/SDIO are switched off upon a PRCM module request. They are switched back upon module request. The MMC/SD/SDIO host controller complies with the PRCM module handshaking protocol:

- Idle request from the system power manager
- Idle acknowledgment from the MMC/SD/SDIO host controller

The idle acknowledgment varies according to the SD_SYSCONFIG[4:3] SIDLEMODE bit field:

- 0: Force-idle mode. The MMC/SD/SDIO host controller acknowledges the system power manager request unconditionally.
- 1h: No-idle mode. The MMC/SD/SDIO host controller ignores the system power manager request and behaves normally as if the request was not asserted.
- 2h: Smart-idle mode. The MMC/SD/SDIO host controller acknowledges the system power manager request according to its internal state.
- 3h: Reserved.

During the smart-idle mode period, the MMC/SD/SDIO host controller acknowledges that the OCP and Functional clocks may be switched off whatever the value set in the SD_SYSCONFIG[9:8] CLOCKACTIVITY field.

13.3.3.3.3.3 Transition from Normal Mode to Smart-Idle Mode

Smart-idle mode is enabled when the SD_SYSCONFIG[4:3] SIDLEMODE bit field is set to 2h or 3h. The MMC/SD/SDIO host controller goes into idle mode when the PRCM issues an idle request, according to its internal activity. The MMC/SD/SDIO host controller acknowledges the idle request from the PRCM after ensuring the following:

- The current multi/single-block transfer is completed.
- Any interrupt or DMA request is asserted.
- There is no card interrupt on the SD_dat1 signal.

As long as the MMC/SD/SDIO controller does not acknowledge the idle request, if an event occurs, the MMC/SD/SDIO host controller can still generate an interrupt or a DMA request. In this case, the module ignores the idle request from the PRCM.

As soon as the MMC/SD/SDIO controller acknowledges the idle request from the PRCM:

- If Smart-Idle mode the module does not assert any new interrupt or DMA request

13.3.3.3.3.4 Transition from Smart-Idle Mode to Normal Mode

The MMC/SD/SDIO host controller detects the end of the idle period when the PRCM deasserts the idle request. For the wake-up event, there is a corresponding interrupt status in the SD_STAT register. The MMC/SD/SDIO host controller operates the conversion between wake-up and interrupt (or DMA request) upon exit from smart-idle mode if the associated enable bit is set in the SD_ISE register.

Interrupts and wake-up events have independent enable/disable controls, accessible through the SD_HCTL and SD_ISE registers. The overall consistency must be ensured by software.

The interrupt status register SD_STAT is updated with the event that caused the wake-up in the CIRQ bit when the SD_IE[8] CIRQ_ENABLE associated bit is enabled. Then, the wake-up event at the origin of the transition from smart-idle mode to normal mode is converted into its corresponding interrupt or DMA request. (The SD_STAT register is updated and the status of the interrupt signal changes.)

When the idle request from the PRCM is deasserted, the module switches back to normal mode. The module is fully operational.

13.3.3.3.3.5 Force-Idle Mode

Force-idle mode is enabled when the SD_SYSCONFIG[4:3] SIDLEMODE bit field is cleared to 0. Force-idle mode is an idle mode where the MMC/SD/SDIO host controller responds unconditionally to the idle request from the PRCM. Moreover, in this mode, the MMC/SD/SDIO host controller unconditionally deasserts interrupts and DMA request lines are asserted.

The transition from normal mode to force-idle mode does not affect the bits of the SD_STAT register. In force-idle mode, the interrupt and DMA request lines are deasserted. Interface Clock (OCP) and functional clock (CLKADPI) can be switched off.

CAUTION

In Force-idle mode, an idle request from the PRCM during a command or a data transfer can lead to an unexpected and unpredictable result. When the module is idle, any access to the module generates an error as long as the OCP clock is alive.

The module exits the force-idle mode when the PRCM deasserts the idle request. Then the module switches back to normal mode. The module is fully operational. Interrupt and DMA request lines are optionally asserted one clock cycle later.

13.3.3.3.6 Local Power Management

Table 13-232 describes power-management features available for the MMC/SD/SDIO modules.

Table 13-232. Local Power Management Features

Feature	Registers	Description
Clock Auto Gating	SD_SYSCONFIG AUTOIDLE bit	This bit allows a local power optimization inside module, by gating the OCP clock upon the interface activity or gating the CLKADPI clock upon the internal activity.
Slave Idle Modes	SD_SYSCONFIG SIDLEMODE bit	Force-idle, No-idle, and Smart-idle modes
Clock Activity	SD_SYSCONFIG CLOCKACTIVITY bit	Please see Table 13-233 for configuration details.
Global Wake-Up Enable	SD_SYSCONFIG ENAWAKEUP bit	This bit enables the wake-up feature at module level.
Wake-Up Sources Enable	SD_HCTL register	This register holds one active high enable bit per event source able to generate wake-up signal.

Table 13-233. Clock Activity Settings

Clock State When Module is in IDLE State					
CLOCKACTIVITY Values	OCP Clock	CLKADPI	Features Available when Module is in IDLE State		
					Wake-Up Events
00	OFF	OFF	None		Card Interrupt
10	OFF	ON	None		
01	ON	OFF	None		
11	ON	ON	All		

CAUTION

The PRCM module has no hardware means of reading CLOCKACTIVITY settings. Thus, software must ensure consistent programming between the CLOCKACTIVITY and MMC clock PRCM control bits.

13.3.3.3.4 Interrupt Requests

Several internal module events can generate an interrupt. Each interrupt has a status bit, an interrupt enable bit, and a signal status enable:

- The status of each type of interrupt is automatically updated in the SD_STAT register; it indicates which service is required.
- The interrupt status enable bits of the SD_IE register enable/disable the automatic update of the SD_STAT register on an event-by-event basis.
- The interrupt signal enable bits of the SD_ISE register enable/disable the transmission of an interrupt request on the interrupt line MMC_IRQ (from the MMC/SD/SDIO host controller to the MPU subsystem interrupt controller) on an event-by-event basis.

If an interrupt status is disabled in the SD_IE register, then the corresponding interrupt request is not transmitted, and the value of the corresponding interrupt signal enable in the SD_ISE register is ignored.

When an interrupt event occurs, the corresponding status bit is automatically set to 1 (the MMC/SD/SDIO host controller updates the status bit) in the SD_STAT register. If later a mask is applied on the interrupt in the SD_ISE register, the interrupt request is deactivated.

When the interrupt source has not been serviced, if the interrupt status is cleared in the SD_STAT register and the corresponding mask is removed from the SD_ISE register, the interrupt status is not asserted again in the SD_STAT register and the MMC/SD/SDIO host controller does not transmit an interrupt request.

CAUTION

If the buffer write ready interrupt (BWR) or the buffer read ready only interrupt (BRR) are not serviced and are cleared in the SD_STAT register, and the corresponding mask is removed, then the MMC/SD/SDIO host controller will wait for the service of the interrupt without updating the status SD_STAT or transmitting an interrupt request.

Table 13-234 lists the event flags, and their mask, that can cause module interrupts.

Table 13-234. Events

Event Flag	Event Mask	Map To	Description
SD_STAT[29] BADA	SD_IE[29] BADA_ENABLE	MMC_IRQ	Bad Access to Data space. This bit is set automatically to indicate a bad access to buffer when not allowed. This bit is set during a read access to the data register (SD_DATA) while buffer reads are not allowed (SD_PSTATE[11] BRE=0). This bit is set during a write access to the data register (SD_DATA) while buffer writes are not allowed (SD_STATE[10] BWE=0)
SD_STAT[28] CERR	SD_IE[28] CERR_ENABLE	MMC_IRQ	Card Error. This bit is set automatically when there is at least one error in a response of type R1, R1b, R6, R5 or R5b. Only bits referenced as type E(error) in status field in the response can set a card status error. An error bit in the response is flagged only if corresponding bit in card status response errors SD_CSRE is set. There is not card detection for auto CMD12 command.
SD_STAT[25] ADMAE	SD_IE[25] ADMAE_ENABLE	MMC_IRQ	ADMA error. This bit is set when the host controller detects errors during ADMA based data transfer. The stat of the ADMA at an error occurrence is saved in the ADMA Error Status Register. In addition, the host controller generates this interrupt when it detects invalid descriptor data (Valid=0) at the ST_FDS state.
SD_STAT[24] ACE	SD_IE[24] ACE_ENABLE	MMC_IRQ	Auto CMD12 error. This bit is set automatically when one of the bits in Auto CMD12 Error status register has changed from 0 to 1
SD_STAT[22] DEB	SD_IE[22] DEB_ENABLE	MMC_IRQ	Data End Bit error. This bit is set automatically when detecting a 0 at the end bit position of read data on DAT line or at the end position of the CRC status in write mode.
SD_STAT[21] DCRC	SD_IE[21] DCRC_ENABLE	MMC_IRQ	Data CRC error. This bit is set automatically when there is a CRC16 error in the data phase response following a block read command or if there is a 3-bit CRC status different of a position "010" token during a block write command.

Table 13-234. Events (continued)

Event Flag	Event Mask	Map To	Description
SD_STAT[20] DTO	SD_IE[20] DTO_ENABLE	MMC_IRQ	Data Timeout error. This bit is set automatically according to the following conditions: A) busy timeout for R1b, R5b response. B) busy timeout after write CRC status. C) write CRC status timeout, or D) read data timeout.
SD_STAT[19] CIE	SD_IE[19] CIE_ENABLE	MMC_IRQ	Command Index Error. This bit is set automatically when response index differs from corresponding command index previously emitted. The check is enabled through SD_CMD[20] CICE bit.
SD_STAT[18] CEB	SD_IE[18] CEB_ENABLE	MMC_IRQ	Command End Bit error. This bit is set automatically when detecting a 0 at the end bit position of a command response.
SD_STAT[17] CCRC	SD_IE[17] CCRC_ENABLE	MMC_IRQ	Command CRC error. This bit is set automatically when there is a CRC7 error in the command response. CRC check is enabled through the SD_CMD[19] CCCE bit.
SD_STAT[16] CTO	SD_IE[16] CTO_ENABLE	MMC_IRQ	Command Timeout error. This bit is set automatically when no response is received within 64 clock cycles from the end bit of the command. For commands the reply within 5 clock cycles, the timeout is still detected at 64 clock cycles.
SD_STAT[15] ERR1	SD_IE[15] ERR1_ENABLE	MMC_IRQ	Error Interrupt. If any of the bits in the Error Interrupt Status register (SD_STAT[24:15]) are set, the this bit is set to 1.
SD_STAT[10] BSR	SD_IE[10] BSR_ENABLE	MMC_IRQ	Boot Status Received interrupt. This bit is set automatically when SD_CON[18] BOOT_CF0 is set to 1 or 2h and boot status is received on the dat0 line. This interrupt is only used for MMC cards.
SD_STAT[8] CIRQ	SD_IE[8] CIRQ_ENABLE	MMC_IRQ	Card Interrupt. This bit is only used for SD, SDIO, and CE-ATA cards. In 1-bit mode, interrupt source is asynchronous (can be a source of asynchronous wake-up). In 4-bit mode, interrupt source is sampled during the interrupt cycle. In CE-ATA mode, interrupt source is detected when the card drive CMD line to zero during one cycle after data transmission end.
SD_STAT[5] BRR	SD_IE[5] BRR_ENABLE	MMC_IRQ	Buffer Read ready. This bit is set automatically during a read operation to the card when one block specified by SD_BLK[10:0] BLEN is completely written in the buffer. It indicates that the memory card has filled out the buffer and the local host needs to empty the buffer by reading it.
SD_STAT[4] BWR	SD_IE[4] BWR_ENABLE	MMC_IRQ	Buffer Write ready. This bit is automatically set during a write operation to the card when the host can write a complete block as specified by SD_BLK[10:0] BLEN. It indicates that the memory card has emptied one block from the buffer and the local host is able to write one block of data into the buffer.
SD_STAT[3] DMA	SD_IE[3] DMA_ENABLE	MMC_IRQ	DMA interrupt. This status is set when an interrupt is required in the ADMA instruction and after the data transfer is complete.
SD_STAT[2] BGE	SD_IE[2] BGE_ENABLE	MMC_IRQ	Block Gap event. When a stop at block gap is requested (SD_HCTL[16] SBGR), this bit is automatically set when transaction is stopped at the block gap during a read or write operation.
SD_STAT[1] TC	SD_IE[1] TC_ENABLE	MMC_IRQ	Transfer completed. This bit is always set when a read/write transfer is completed or between two blocks when the transfer is stopped due to a stop at block gap requested (SD_HCTL[16] SBGR). In read mode this bit is automatically set on completion of a read transfer (SD_PSTATE[9] RTA). In write mode, this bit is automatically set on completion of the DAT line use (SD_PSTATE[2] DLA).
SD_STAT[0] CC	SD_IE[0] CC_ENABLE	MMC_IRQ	Command complete. This bit is set when a 1-to-0 transition occurs in the register command inhibit (SD_PSTATE[0] CMDI). If the command is a type for which no response is expected, then the command complete interrupt is generated at the end of the command. A command timeout error (SD_STAT[16] CTO) has higher priority than command complete (SD_STAT[0] CC). If a response is expected but none is received, the a Command Timeout error is detected and signaled instead of the Command Complete interrupt.

13.3.3.3.4.1 Interrupt-Driven Operation

An interrupt enable bit must be set in the SD_IE register to enable the module internal source of interrupt.

When an interrupt event occurs, the single interrupt line is asserted and the LH must:

- Read the SD_STAT register to identify which event occurred.
- Write 1 into the corresponding bit of the SD_STAT register to clear the interrupt status and release the interrupt line (if a read is done after this write, this would return 0).

Note

In the SD_STAT register, Card Interrupt (CIRQ) and Error Interrupt (ERRI) bits cannot be cleared.

The SD_STAT[8] CIRQ status bit must be masked by disabling the SD_IE[8] CIRQ_ENABLE bit (cleared to 0), then the interrupt routine must clear SDIO interrupt source in SDIO card common control register (CCCR).

The SD_STAT[15] ERRI bit is automatically cleared when all status bits in SD_STAT[31:16] are cleared.

13.3.3.3.4.2 Polling

When the interrupt capability of an event is disabled in the SD_ISE register, the interrupt line is not asserted:

- Software can poll the status bit in the SD_STAT register to detect when the corresponding event occurs.
- Writing 1 into the corresponding bit of the SD_STAT register clears the interrupt status and does not affect the interrupt line state.

Note

Please see the note in [Section 13.3.3.3.4.1](#) concerning CIRQ and ERRI bits clearing.

13.3.3.3.5 DMA Modes

The device supports DMA slave mode only. In this case, the controller is slave on DMA transaction managed by two separated requests (SDMAWREQN and SDMARREQN)

13.3.3.3.5.1 DMA Slave Mode Operations

The MMC/SD/SDIO controller can be interfaced with a DMA controller. At system level, the advantage is to discharge the local host (LH) of the data transfers. The module does not support wide DMA access (above 1024 bytes) for SD cards as specified in the *SD Card Specification* and *SD Host Controller Standard Specification*.

The DMA request is issued if the following conditions are met:

- The SD_CMD[0] DE bit is set to 1 to trigger the initial DMA request (the write must be done when running the data transfer command).
- A command was emitted on the SD_cmd line.
- There is enough space in the buffer of the MMC/SD/SDIO controller to write an entire block (BLEN writes).

13.3.3.3.5.1.1 DMA Receive Mode

In a DMA block read operation (single or multiple), the request signal SDMARREQN is asserted to its active level when a complete block is written in the buffer. The block size transfer is specified in the SD_BLK[10:0] BLEN field.

The SDMARREQN signal is deasserted to its inactive level when the sDMA has read one single word from the buffer. Only one request is sent per block; the DMA controller can make a 1-shot read access or several DMA bursts, in which case the DMA controller must manage the number of burst accesses, according to block size BLEN field.

New DMA requests are internally masked if the sDMA has not read exactly BLEN bytes and a new complete block is not ready. As DMA accesses are in 32-bit, then the number of sDMA read is Integer(BLEN/4)+1.

The receive buffer never overflows. In multiple block transfers for block size above 512 bytes, when the buffer gets full, the MMC_CLK clock signal (provided to the card) is momentarily stopped until the sDMA or the MPU performs a read access, which reads a complete block in the buffer.

Figure 13-195 provides a summary:

- DMA transfer size = BLEN buffer size in one shot or by burst
- One DMA request per block

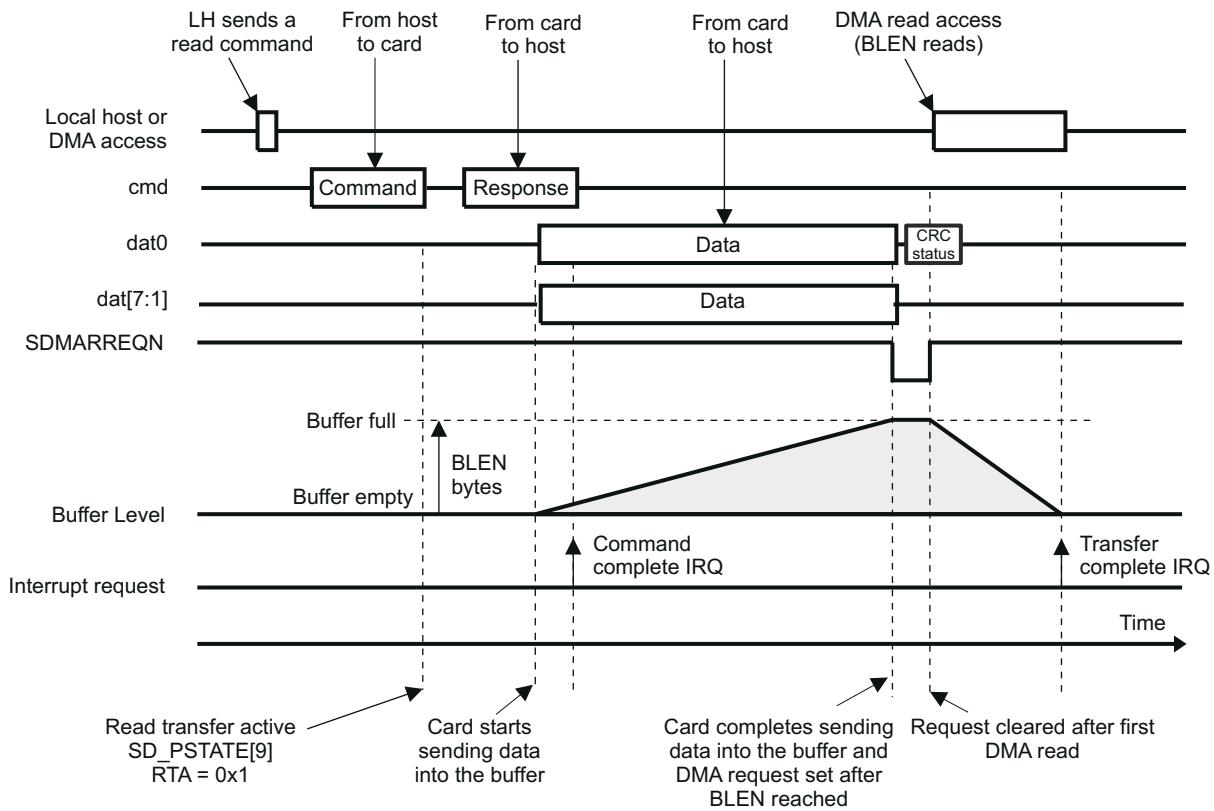

Figure 13-195. DMA Receive Mode

13.3.3.3.5.1.2 DMA Transmit Mode

In a DMA block write operation (single or multiple), the request signal SDMAWREQN is asserted to its active level when a complete block is to be written to the buffer. The block size transfer is specified in the SD_BLK[10:0] BLEN field.

The SDMAWREQN signal is deasserted to its inactive level when the sDMA has written one single word to the buffer.

Only one request is sent per block; the DMA controller can make a 1-shot write access or multiple write DMA bursts, in which case the DMA controller must manage the number of burst accesses, according to block size BLEN field.

New DMA requests are internally masked if the sDMA has not written exactly BLEN bytes (as DMA accesses are in 32-bit, then the number of sDMA read is Integer(BLEN/4)+1) and if there is not enough memory space to write a complete block in the buffer.

Figure 13-196 provides a summary:

- DMA transfer size = BLEN buffer size in one shot or by burst
- One DMA request per block

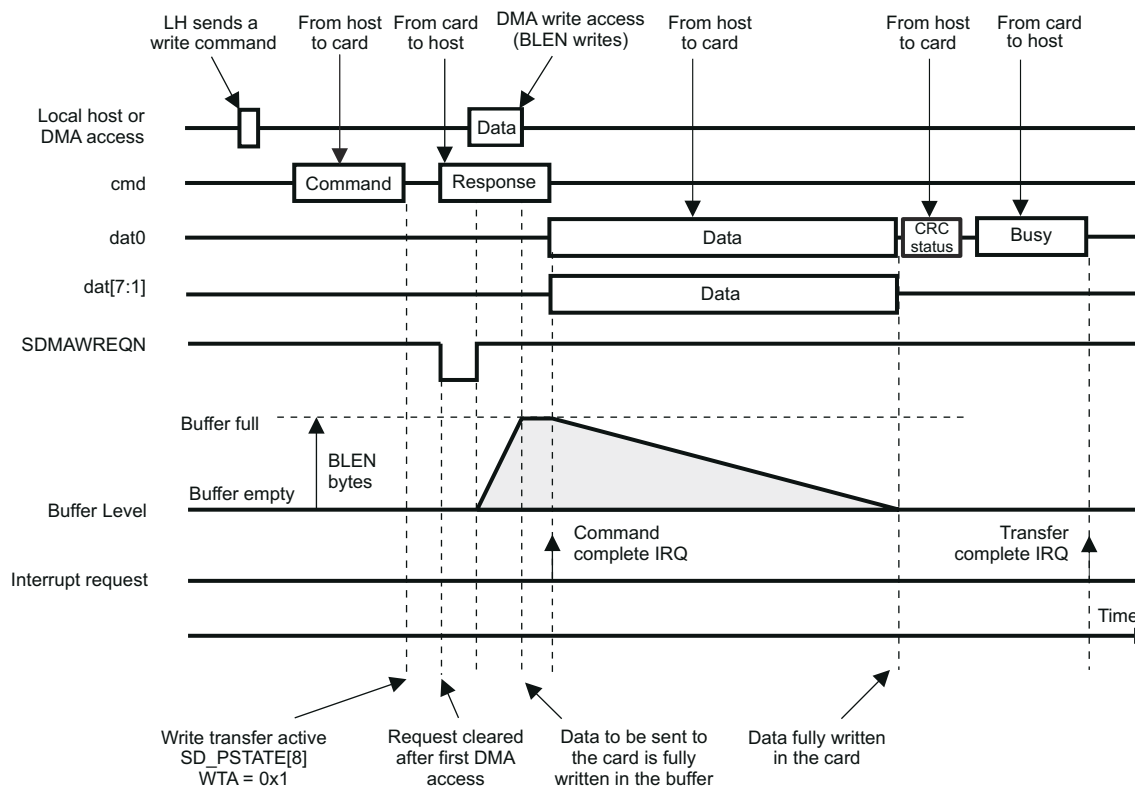

Figure 13-196. DMA Transmit Mode

13.3.3.3.6 Mode Selection

The MMC/SD/SDIO host controller can be use in two modes, MMC and SD/SDIO modes. It has been designed to be the most transparent with the type of card. The type of the card connected is differentiated by the software initialization procedure.

Software identifies the type of card connected during software initialization. For each given card type, there are corresponding commands. Some commands are not supported by all cards. See the *Multimedia Card System Specification*, the *SD Memory Card Specifications*, and the *SDIO Card Specification, Part E1* for more details.

The purpose of the module is to transfer commands and data, to whatever card is connected, respecting the protocol of the connected card. Writes and reads to the card must respect the appropriate protocol of that card.

13.3.3.3.7 Buffer Management

13.3.3.3.7.1 Data Buffer

The MMC/SD/SDIO host controller uses a data buffer. This buffer transfers data from one data bus (Interconnect) to another data bus (SD, SDIO, or MMC card bus) and vice versa.

The buffer is the heart of the interface and ensures the transfer between the two interfaces (L4 and the card). To enhance performance, the data buffer is completed by a prefetch register and a post-write buffer that are not accessible by the host controller.

The read access time of the prefetch register is faster than the one of the data buffer. The prefetch register allows data to be read from the data buffer at an increased speed by preloading data into the prefetch register.

The entry point of the data buffer, the prefetch buffer, and the post-write buffer is the 32-bit register SD_DATA. A write access to the SD_DATA register followed by a read access from the SD_DATA register corresponds to a write access to the post-write buffer followed by a read access to the prefetch buffer. As a consequence, it is normal that the data of the write access to the SD_DATA register and the data of the read access to the SD_DATA register are different.

The number of 32-bit accesses to the SD_DATA register that are needed to read (or write) a data block with a size of SD_BLK[10:0] BLEN, and equals the rounded up result of BLEN divided by 4. The maximum block size supported by the host controller is hard-coded in the register SD_CAPA[17:16] MBL field and cannot be changed.

A read access to the SD_DATA register is allowed only when the buffer read enable status is set to 1 (SD_PSTATE[11] BRE); otherwise, a bad access (SD_STAT[29] BADA) is signaled.

A write access to the SD_DATA register is allowed only when the buffer write enable status is set to 1 (SD_PSTATE[10] BWE); otherwise, a bad access (SD_STAT[29] BADA) is signaled and the data is not written.

The data buffer has two modes of operation to store and read of the first and second portions of the data buffer:

- When the size of the data block to transfer is less than or equal to MEM_SIZE/2 (in double buffering), two data transfers can occur from one data bus to the other data bus and vice versa at the same time. The MMC/SD/SDIO controller uses the two portions of the data buffer in a ping-pong manner so that storing and reading of the first and second portions of the data buffer are automatically interchanged from time to time so that data may be read from one portion (for instance, through a DMA read access on the interconnect bus) while data (for instance, from the card) is being stored into the other portion and vice versa. When BLEN is less than or equal to 200h (that is, less or equal to 512Bytes), each of the two portions of the buffer that can be used have a size of BLEN (that is, 32-bits x BLEN div by 4). Not more than this total size of 2 times 32-bits x BLEN div by 4 can be used.
- When the size of the data block to transfer is larger than MEM_SIZE/2, only one data transfer can occur from one data bus to the other data bus at a time. The MMC/SD/SDIO host controller uses the entire data buffer as a single portion. In this mode, a bad access (SD_STAT[29] BADA) is signaled when two data transfers occur from one data bus to the other data bus and vice versa at the same time.

CAUTION

The SD_CMD[4] DDIR bit must be configured before a transfer to indicate the direction of the transfer.

Figure 13-197 shows the buffer management for writing and Figure 13-198 shows the buffer management for reading.

ADVANCE INFORMATION

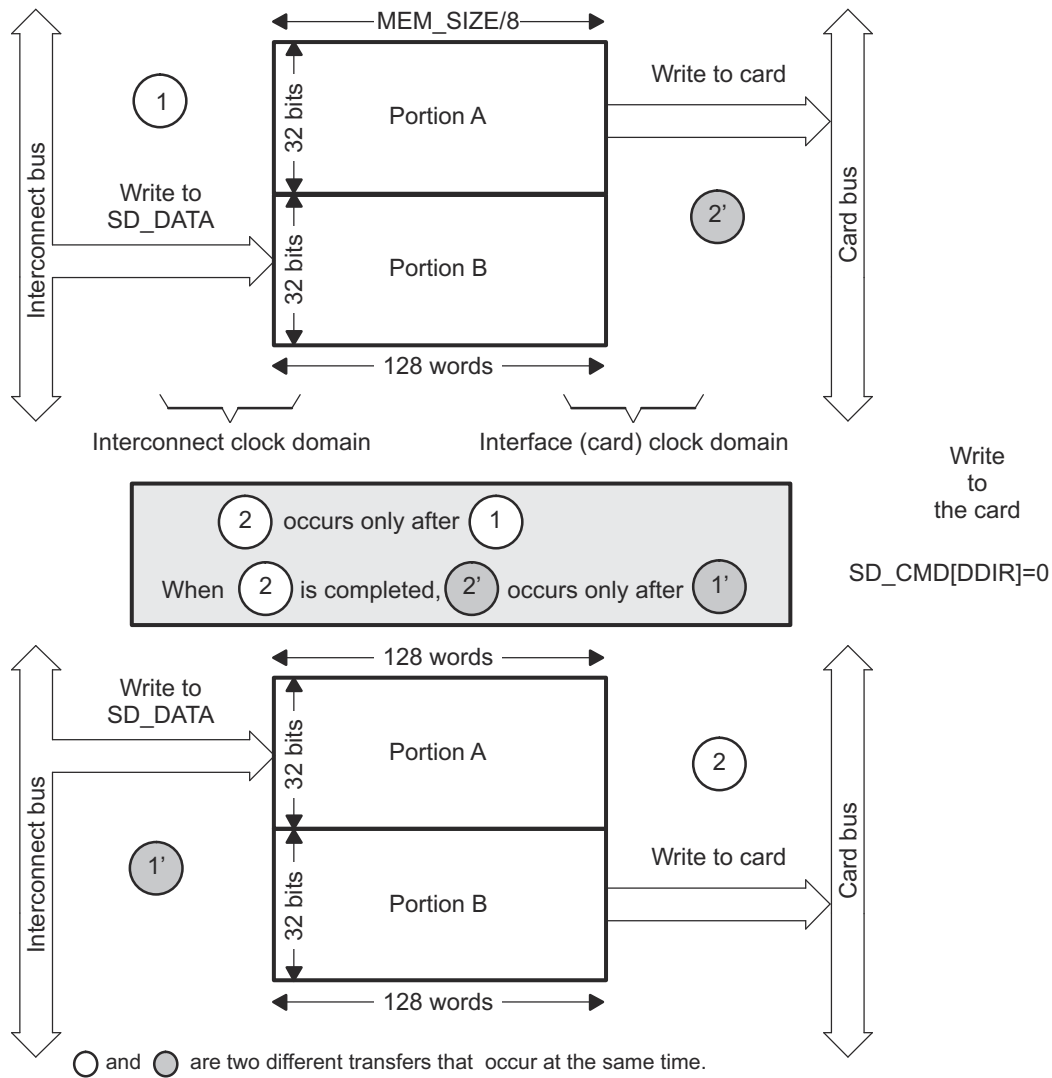

Figure 13-197. Buffer Management for a Write

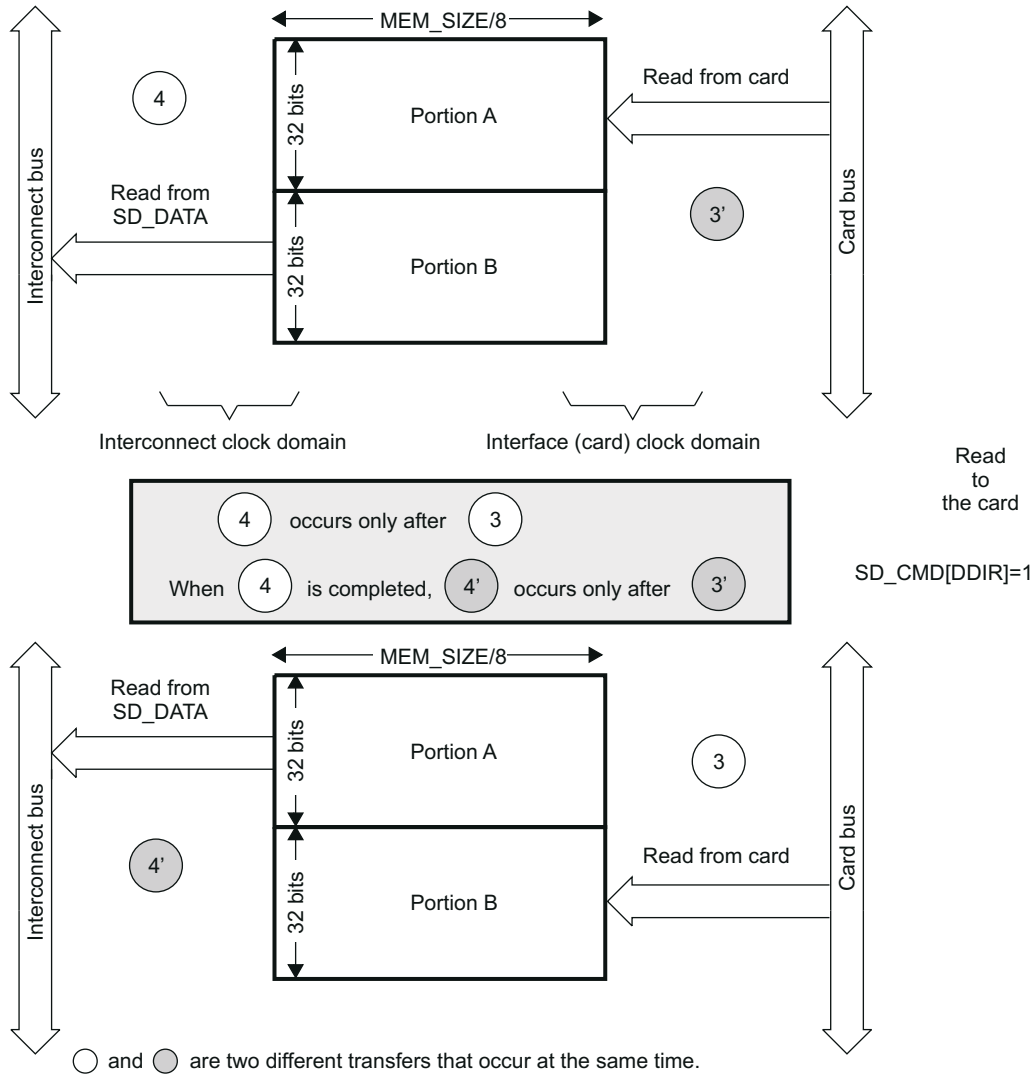

Figure 13-198. Buffer Management for a Read

13.3.3.7.1.1 Memory Size, Block Length, and Buffer Management Relationship

The maximum block length and buffer management that can be targeted by system depend on memory depth setting.

Table 13-235. Memory Size, BLEN, and Buffer Relationship

Memory Size([5:2] MEMSIZE in bytes)	512	1024	2048	4096
Maximum block length supported	512	1024	2048	2048
Double-buffering for maximum block length	N/A	BLEN <= 512	BLEN <= 1024	BLEN <= 2048
Single-buffering for block length	BLEN <= 512	512 < BLEN <= 1024	1024 < BLEN <= 2048	N/A

13.3.3.3.7.1.2 Data Buffer Status

The data buffer status is defined in the following interrupt status register and status register:

- Interrupt status registers (see SD_STAT):
 - SD_STAT[29] BADA Bad access to data space
 - SD_STAT[5] BRR Buffer read ready
 - SD_STAT[4] BWR Buffer write ready
- Status registers (see SD_PSTATE):
 - SD_PSTATE[11] BRE Buffer read enable
 - SD_PSTATE[10] BWE Buffer write enable

13.3.3.3.8 Transfer Process

The process of a transfer is dependent on the type of command. It can be with or without a response, with or without data.

13.3.3.3.8.1 Different Types of Commands

Different types of commands are specific to MMC, SD, or SDIO cards. See the *Multimedia Card System Specification*, the *SD Memory Card Specifications*, the *SDIO Card Specification, Part E1*, or the *SD Card Specification, Part A2, SD Host Controller Standard Specification* for more details.

13.3.3.3.8.2 Different Types of Responses

Different types of responses are specific to MMC, SD, or SDIO cards. See the *Multimedia Card System Specification*, the *SD Memory Card Specifications*, the *SDIO Card Specification, Part E1*, or the *SD Card Specification, Part A2, SD Host Controller Standard Specification* for more details.

Table 13-236 shows how the MMC, SD, and SDIO responses are stored in the SD_RSPxx registers.

Table 13-236. MMC, SD, SDIO Responses in the SD_RSPxx Registers

Kind of Response	Response Field	Response Register
R1, R1b (normal response), R3, R4, R5, R5b, R6, R7	RESP[39:8] ⁽¹⁾	SD_RSP10[31:0]
R1b (Auto CMD12 response)	RESP[39:8] ⁽¹⁾	SD_RSP76[31:0]
R2	RESP[127:0] ⁽¹⁾	SD_RSP76[31:0] SD_RSP54[31:0] SD_RSP32[31:0] SD_RSP10[31:0]

(1) RESP refers to the command response format described in the specifications mentioned above.

When the host controller modifies part of the SD_RSPxx registers, it preserves the unmodified bits.

The host controller stores the Auto CMD12 response in the SD_RSP76[31:0] register because the Host Controller may have a multiple block data DAT line transfer executing concurrently with a command. This allows the host controller to avoid overwriting the Auto CMD12 response with the command response stored in SD_RSP10 register and vice versa.

13.3.3.3.9 Transfer or Command Status and Error Reporting

Flags in the MMC/SD/SDIO host controller show status of communication with the card:

- A timeout (of a command, a data, or a response)
- A CRC

Error conditions generate interrupts. See [Table 13-237](#) and register description for more details.

Table 13-237. CC and TC Values Upon Error Detected

Error hold in the SD_STAT Register		CC	TC	Comments
29	BADA			No dependency with CC or TC. BADA is related to the register accesses. Its assertion is not dependent of the ongoing transfer.
28	CERR	1		CC is set upon CERR.
22	DEB		1	TC is set upon DEB.
21	DCRC		1	TC is set upon DCRC.
20	DTO			DTO and TC are mutually exclusive. DCRC and DEB cannot occur with DTO.
19	CIE	1		CC is set upon CIE.
18	CEB	1		CC is set upon CEB.
17	CCRC	1		CC can be set upon CCRC - See CTO comment
16	CTO			CTO and CC are mutually exclusive. CIE, CEB and CERR cannot occur with CTO. CTO can occur at the same time as CCRC it indicates a command abort due to a contention on CMD line. In this case no CC appears.

SD_STAT[21] DCRC event can be asserted in the following conditions:

- Busy timeout for R1b, R5b response type
- Busy timeout after write CRC status
- Write CRC status timeout
- Read data timeout
- Boot acknowledge timeout

13.3.3.3.9.1 Busy Timeout for R1b, R5b Response Type

Figure 13-199 shows DCRD event condition asserted when there is a busy timeout for R1b or R5b responses.

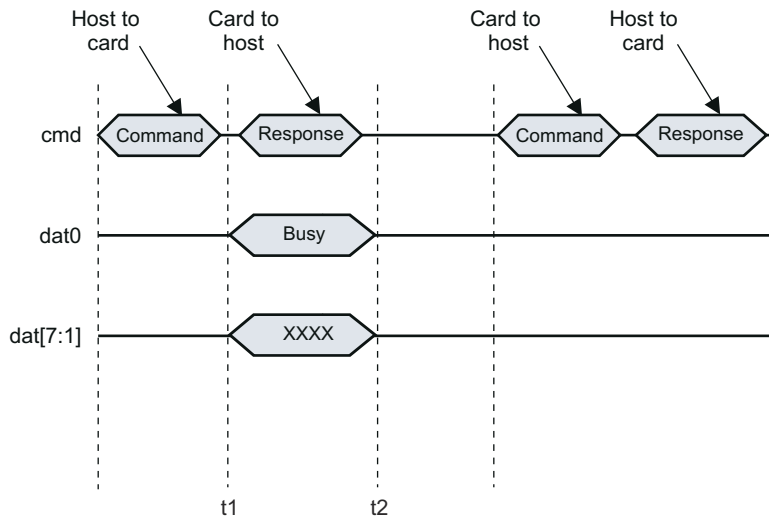

Figure 13-199. Busy Timeout for R1b, R5b Responses

t1 - Data timeout counter is loaded and starts after R1b, R5b response type.

t2 - Data timeout counter stops and if it is 0, SD_STAT[21] DCRC is generated.

13.3.3.3.9.2 Busy Timeout After Write CRC Status

Figure 13-200 shows DCRD event condition asserted when there is busy timeout after write CRC status.

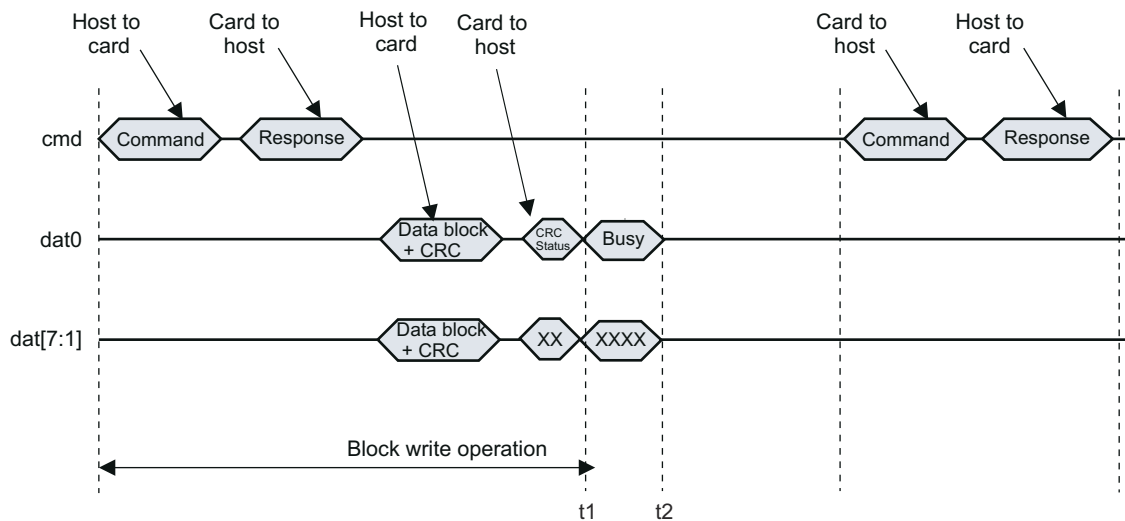

Figure 13-200. Busy Timeout After Write CRC Status

t1 - Data timeout counter is loaded and starts after CRC status.

t2 - Data timeout counter stops and if it is 0, SD_STAT[21] DCRC is generated.

13.3.3.3.9.3 Write CRC Status Timeout

Figure 13-201 shows DCRC event condition asserted when there is write CRC status timeout.

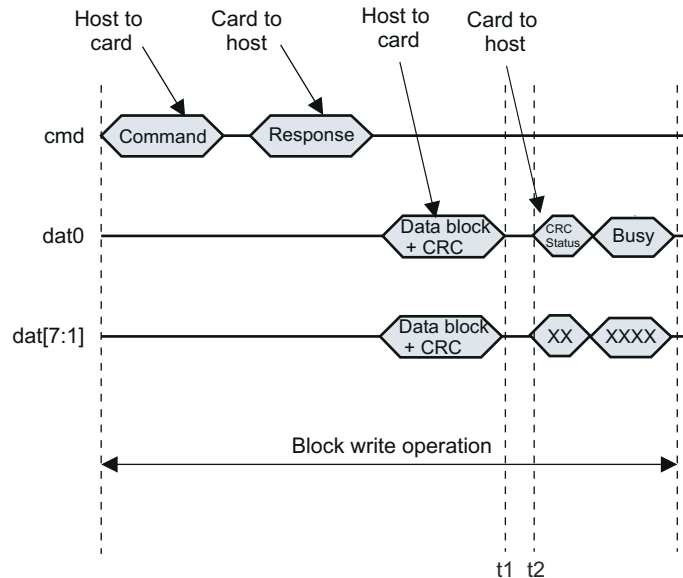

Figure 13-201. Write CRC Status Timeout

t1 - Data timeout counter is loaded and starts after Data block + CRC.

t2 - Data timeout counter stops and if it is 0, SD_STAT[21] DCRC is generated.

13.3.3.3.9.4 Read Data Timeout

Figure 13-202 shows DCRC event condition asserted when there is read data timeout.

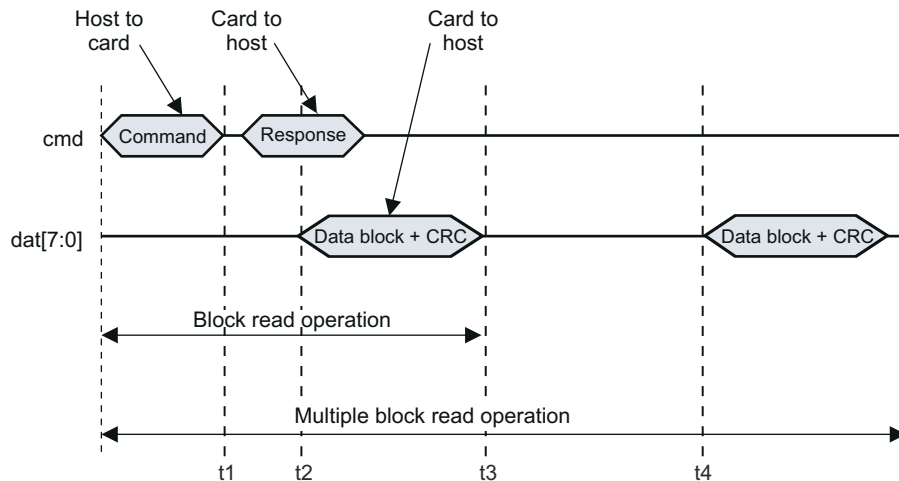

Figure 13-202. Read Data Timeout

t1 - Data timeout counter is loaded and starts after Command transmission.

t2 - Data timeout counter stops and if it is 0, SD_STAT[21] DCRC is generated.

t3 - Data timeout counter is loaded and starts after Data block + CRC transmission.

t4 - Data timeout counter stops and if it is 0, SD_STAT[21] DCRC is generated.

13.3.3.3.9.5 Boot Acknowledge Timeout

Figure 13-203 shows DCRC event condition asserted when there is boot acknowledge timeout and CMD0 is used.

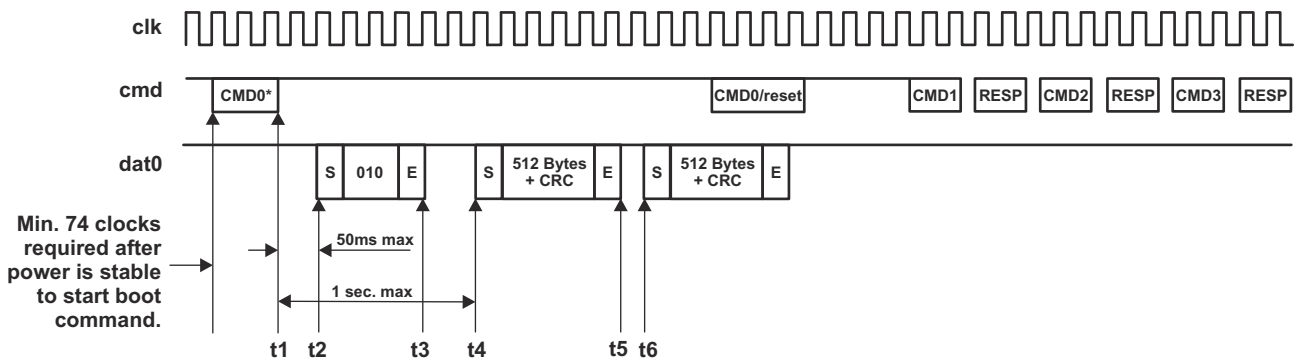

* Refer to MMC Specification for correct argument.

Figure 13-203. Boot Acknowledge Timeout When Using CMD0

- t1 - Data timeout counter is loaded and starts after CMD0.
- t2 - Data timeout counter stops and if it is 0, SD_STAT[21] DCRC is generated.
- t3 - Data timeout counter is loaded and starts.
- t4 - Data timeout counter stops and if it is 0, SD_STAT[21] DCRC is generated.
- t5 - Data timeout counter is loaded and starts after Data + CRC transmission.
- t6 - Data timeout counter stops and if it is 0, SD_STAT[21] DCRC is generated.

Figure 13-204 shows DCRC event condition asserted when there is boot acknowledge timeout and CMD line is held low.

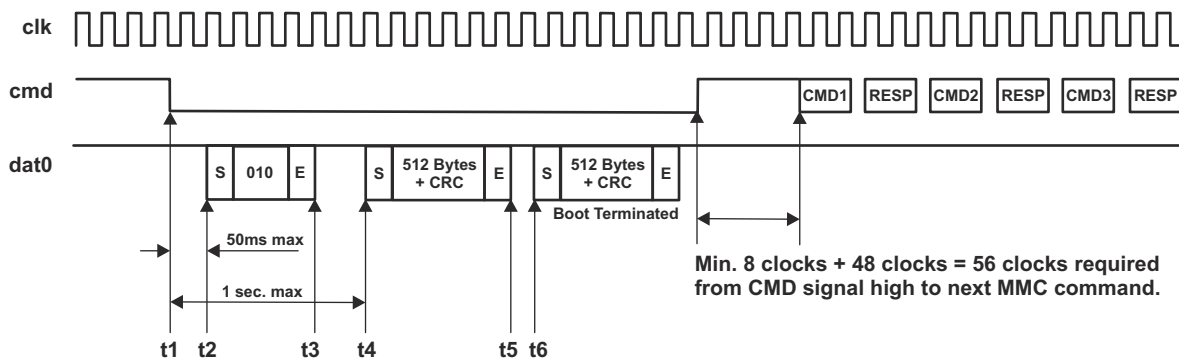

Figure 13-204. Boot Acknowledge Timeout When CMD Held Low

- t1 - Data timeout counter is loaded and starts after cmd line is tied to 0.
- t2 - Data timeout counter stops and if it is 0, SD_STAT[21] DCRC is generated.
- t3 - Data timeout counter is loaded and starts.
- t4 - Data timeout counter stops and if it is 0, SD_STAT[21] DCRC is generated.
- t5 - Data timeout counter is loaded and starts after Data + CRC transmission.
- t6 - Data timeout counter stops and if it is 0, SD_STAT[21] DCRC is generated.

13.3.3.3.10 Auto Command 12 Timings

With the UHS definition of SD cards with higher frequency for MMC clocks up to 208, SD standard imposes a specific timing for Auto CMD12 "end bit" arrival.

13.3.3.3.10.1 Auto Command 12 Timings During Write Transfer

A margin named Nrcr in range of 2 to 8 cycles has been defined for SDR50 and SDR104 card components for write data transfers, as auto command 12 'end bit' shall arrive after the CRC status "end bit".

Figure 13-205 shows auto CMD12 timings during write transfer.

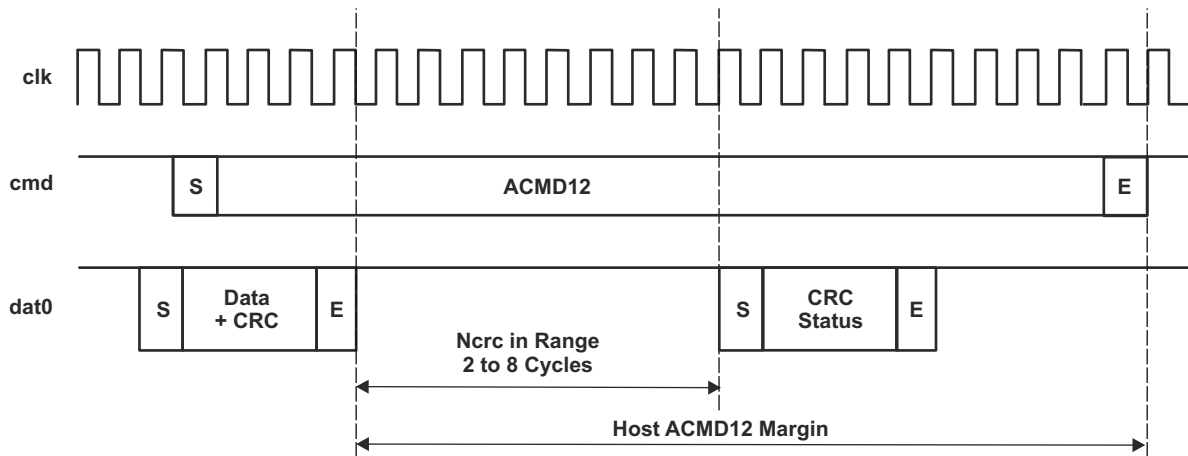

Figure 13-205. Auto CMD12 Timing During Write Transfer

The Host controller has a margin of 18 clock cycles to make sure that auto CMD12 'end bit' arrives after the CRC status. This margin does not depend on MMC bus configuration, DDR or standard transfer, 1,4 or 8 bus width.

13.3.3.3.10.2 Auto Command 12 Timings During Read Transfer

With UHS very high speed cards gap timing between 2 successive cards has been extended to 4 cycles instead of 2. By the way it gives more flexibility for Host Auto CMD12 arrival in order to receive the last complete and reliable block. SD controller only follows the 'Left Border Case' defined by SD UHS specification.

Figure 13-206 shows ACMD12 timings during read transfer.

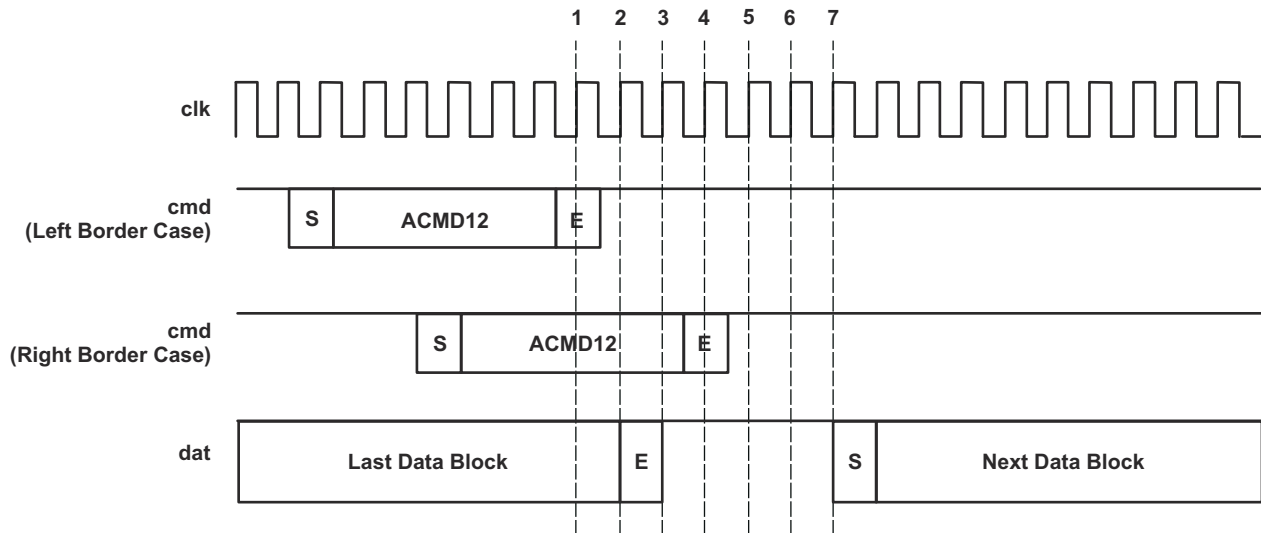

Figure 13-206. Auto Command 12 Timings During Read Transfer

The Auto CMD12 arrival sent by the Host controller is not sensitive to the MMC bus configuration whether it is DDR or standard transfer and whether it is a 1,4 or 8 bit bus width transfer.

13.3.3.3.11 Transfer Stop

Whenever a transfer is initiated, the transmission may be willed to stop whereas it is still not finished. Several cases can be faced depending on the transfer type:

- Multiple blocks oriented transfers (for which transfer length is known)
- Continuous stream transfers (which have an infinite length)

Note

Since the MMC/SD/SDIO controller manages transfers based on a block granularity, the buffer will accept a block only if there is enough space to completely store it. Consequently, if a block is pending in the buffer, no command will be sent to the card because the card clock will be shut off by the controller.

The MMC/SD/SDIO controller includes two features which make a transfer stop more convenient and easier to manage:

- Auto CMD12 (for MMC and SD only).

This feature is enabled by setting the SD_CMD[2] ACEN bit to 1 (this setting is relevant for a MMC/SD transfer with a known number of blocks to transfer). When the Auto CMD12 feature is enabled, the MMC/SD/SDIO controller will automatically issue a CMD12 command when the expected number of blocks has been exchanged.

- Stop at block gap

This feature is enabled by setting the SD_HCTL[16] SBGR bit to 1. When enabled, this capability holds the transfer on until the end of a block boundary. If a stop transmission is needed, software can use this pause to send a CMD12 to the card.

Table 13-238 shows the common ways to stop a transfer, indicating command to send and features to enable.

Table 13-238. MMC/SD/SDIO Controller Transfer Stop Command Summary

		WRITE Transfer		READ Transfer	
		MMC/SD	SDIO	MMC/SD	SDIO
Single block		Transfer ends automatically Wait TC	Transfer ends automatically Wait TC	Transfer ends automatically Wait TC	Transfer ends automatically Wait TC
Multi blocks (finite or infinite)	Before the programmed block boundary	Send CMD12 Wait TC	Send CMD52 Wait TC	Send CMD12 Wait TC	Send CMD52 Wait TC
	Stop at the end of the transfer (finite transfer only)	Auto CMD12 active Transfer ends automatically Wait TC	Set SD_HCTL[16] SBGR bit to 1. Send CMD52 Wait TC	Auto CMD12 active Transfer ends automatically Wait TC	If READ_WAIT supported Stop at block gap Wait TC <hr/> If READ_WAIT not supported Send CMD52 Wait TC

Note

The MMC/SD/SDIO controller will send the stop command to the card on a block boundary, regardless the moment the command was written to the controller registers.

13.3.3.3.12 Output Signals Generation

The MMC/SD/SDIO output signals can be driven on either falling edge or rising edge depending on the SD_HCTL[2] HSPE bit. This feature allows to reach better timing performance, and thus to increase data transfer frequency.

13.3.3.3.12.1 Generation on Falling Edge of MMC Clock

The controller is by default in this mode to maximize hold timings. In this case, SD_HCTL[2] HSPE bit is cleared to 0.

Figure 13-207 shows the output signals of the module when generating from the falling edge of the MMC clock.

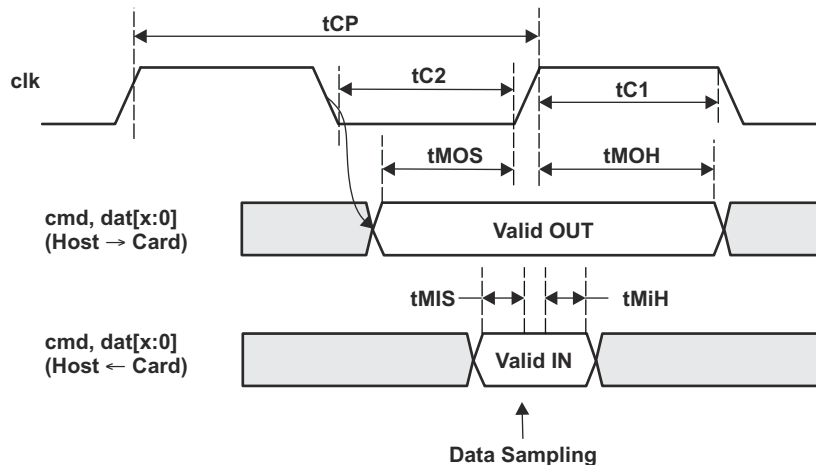

Figure 13-207. Output Driven on Falling Edge

13.3.3.3.12.2 Generation on Rising Edge of MMC Clock

This mode increases setup timings and allows reaching higher bus frequency. This feature is activated by setting SD_HCTL[2] HSPE bit to 1. The controller shall be set in this mode to support SDR transfers.

Note

Do not use this feature in Dual Data Rate mode (when SD_CON[19] DDR is set to 1).

Figure 13-208 shows the output signals of the module when generating from the rising edge of the MMC clock.

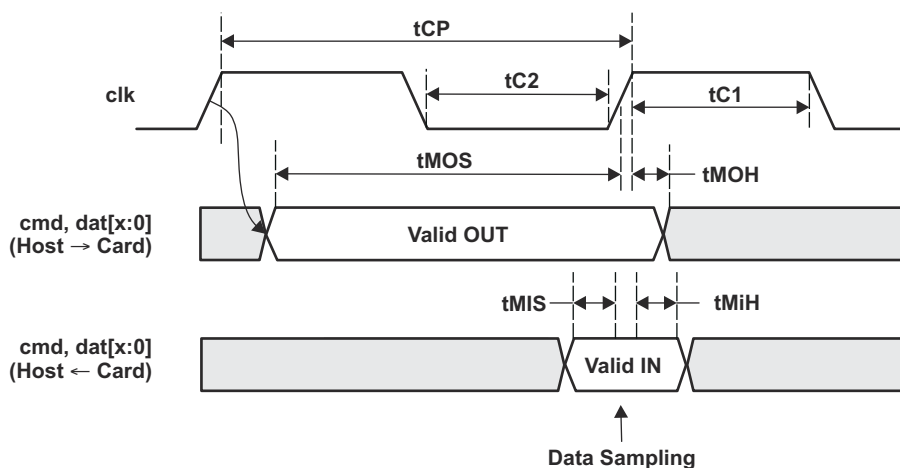

Figure 13-208. Output Driven on Rising Edge

13.3.3.3.13 Card Boot Mode Management

Boot Operation Mode allows the MMC/SD/SDIO host controller to read boot data from the connected slave (MMC device) by keeping CMD line low after power-on (or sending CMD0 with specific argument) before issuing CMD1. The data can be read from either boot area or user area, depending on register setting. Power-on boot defines a way for the boot-code to be accessed by the MMC/SD/SDIO host controller without an upper-level software driver, speeding the time it takes for a controller to access the boot code.

The two possible ways to issue a boot command (either issuing a CMD0 or driving the CMD line to 0 during the whole boot phase) are described in the following sections.

13.3.3.3.13.1 Boot Mode Using CMD0

Figure 13-209 shows the timing diagram of a boot sequence using CMD0.

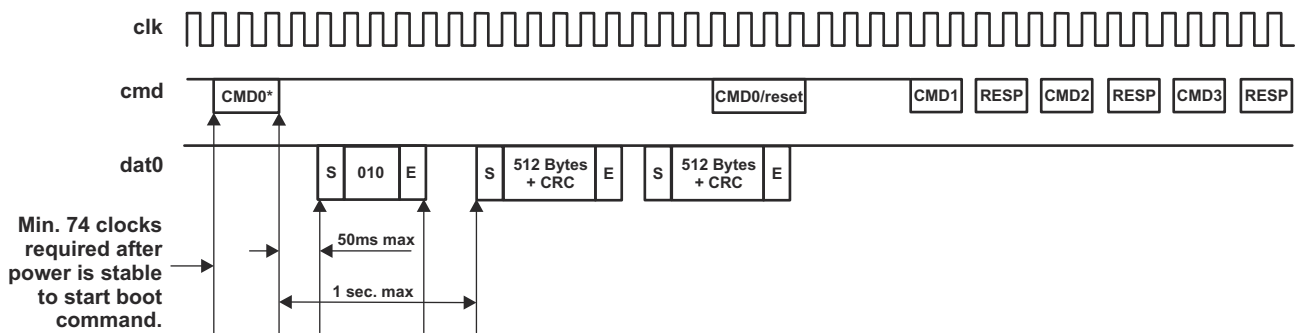

* Refer to MMC Specification for correct argument.

Figure 13-209. Boot Mode With CMD0

- Configure:
 - SD_CON[BOOT_CF0] to 0
 - SD_CON[BOOT_ACK] (if an acknowledge will be received) to 0x1
 - SD_BLK with the correct block length and number of block
 - SD_SYSCTL[DTO] for timeout

If transfer is done in DDR mode also set SD_CON[DDR] to 1.
- Write register SD_ARG with correct argument (see MMC Specification).
- Write in SD_CMD register to start CMD0 transfer with these bit fields set:
 - INDX set to 0x00
 - DP set to '1'
 - DDIR set to '1'
 - MSBS set to '1'
 - BCE set to '1'
- If boot status is not received within the timing defined, the SD_STAT[DTO] will be generated. Otherwise the SD_STAT[BSR] is arisen.
- After the transfer is complete, the controller will generate the SD_STAT[TC], and then the system can emit another CMD0 (SD_CON[BOOT_ACK] previously cleared to 0x0) to exit the card from boot state.
- If the system wants to abort the boot sequence it must issue a CMD0 with SD_CMD[CMD_TYPE] set to 0x3 (SD_CON[BOOT_ACK] previously cleared to 0x0) during the transfer to abort transfer and enable card to exit from boot state.

13.3.3.3.13.2 Boot Mode With CMD Held Low

Figure 13-210 shows the timing diagram of a boot sequence with CMD line tied to 0.

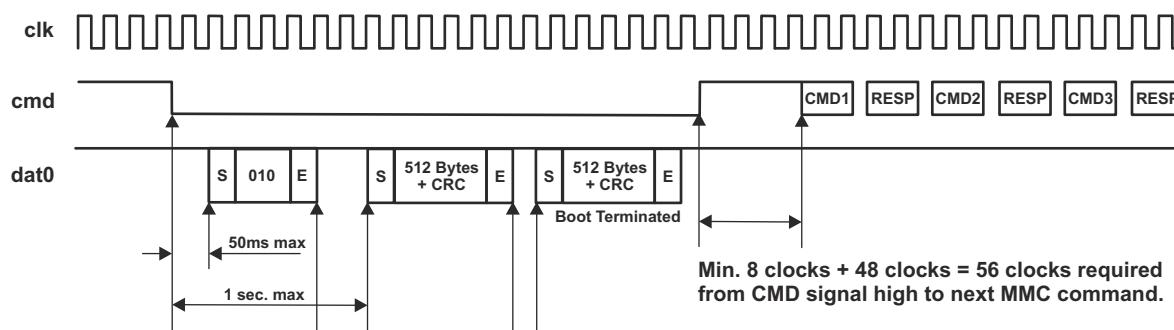
Figure 13-210. Boot Mode With CMD Line Tied to 0

- Configure:
 - SD_CON[BOOT_CF0] and SD_CON[BOOT_ACK] (if an acknowledge will be received) to 0x1
 - SD_BLK with correct block length and number of block
 - SD_SYSCTL[DTO] for timeout

If transfer is done in DDR mode also set SD_CON[DDR] to 1.
- Write in SD_CMD register to start boot sequence with:
 - DP set to '1'
 - DDIR set to '1'
 - MSBS set to '1'
 - BCE set to '1'

This leads the controller to force CMD line to '0'.
- If the boot status is not received within the timing defined, the SD_STAT[DTO] will be generated. Otherwise the SD_STAT[BSR] is arisen.
- After the transfer is complete, the controller will generate the SD_STAT[TC], and then the system must clear SD_CON[BOOT_CF0] to 0x0 to release the CMD line and enable the card to exit from boot state.
- If the system wants to abort the boot sequence it must clear SD_CON[BOOT_CF0] to 0x0 during transfer to enable the card to exit from boot state.

13.3.3.3.14 CE-ATA Command Completion Disable Management

The MMC/SD/SDIO controller supports CE-ATA features, in particular the detection of command completion token. When a command that requires a command completion signal (SD_CON[12] CEATA and SD_CMD[2] ACEN set to 1) is launched, the host system is no longer allowed to emit a new command in parallel of data transfer unless it is a command completion disable token.

The settings to emit a command completion disable token follow:

- SD_CON[12] CEATA is set to 1.
- SD_CON[2] HR set to 1.
- Clear the SD_ARG register.
- Write into SD_CMD register with value 0000 0000h.

When a command completion disable token was emitted (that is, SD_STAT[0] CC received), the host system is again allowed to emit another type of command (for example a transfer abort command CMD12 to abort transfer).

A critical case can be met when command completion signal disable (CCSD) is emitted during the last data block transfer, the sequence on command line could be sent very close to command completion signal (CCS) token sent by the card.

Three cases can be met:

- CCS is receive just before CCSD is emitted:

An interrupt CIRQ is generated with CCS detection, CCSD is transmitted to card then an interrupt CC is generated when CCSD ends. In this case, card consider the CCSD sequence.

- CCS is not generated or generated during the CCSD transfer:

The CCS bit cannot be detected (conflict is not possible as they drive the same level on command line, then no CIRQ interrupt is generated; besides CC interrupt is generated when CCSD ends).

- CCS is generated without CCSD token required:

Only the interrupt CIRQ is generated when CCS is detected.

13.3.3.3.15 Test Registers

Test registers are available to be compliant with SD Host controller specification. This feature is useful to generate interrupts manually for driver debugging. The Force Event register (SD_FE) is used to control the Error Interrupt Status and Auto CMD12 Error Status. The System Test register (SD_SYSTEST) is used to control the signals that connect to I/O pins when the module is configured in system test (SD_CON[4] MODE = 1) mode for boundary connectivity verification.

13.3.3.3.16 MMC/SD/SDIO Hardware Status Features

Table 13-239 summarizes the MMC/SD/SDIO hardware status features.

Table 13-239. MMC/SD/SDIO Hardware Status Features

Feature	Type	Register/Bit Field/Observability Control	Description
Interrupt flags		See Section 13.3.3.3.4 .	
CMD line signal level	Status	[24] CLEV	Indicates the level of the cmd line
DAT lines signal level	Status	[23:20] DLEV	Indicates the level of the data lines
Buffer read enable	Status	[11] BRE	Readable data exists in the buffer.
Buffer write enable	Status	[10] BWE	Indicates whether there is enough space in the buffer to write BLEN bytes of data
Read transfer active	Status	[9] RTA	This status is used for detecting completion of a read transfer.
Write transfer active	Status	[8] WTA	This status indicates a write transfer active.
Data line active	Status	[2] DLA	Indicates whether the data lines are active
Command Inhibit (data lines)	Status	[1] DATI	Indicates whether issuing of command using data lines is allowed
Command inhibit (CMD line)	Status	[0] CMDI	Indicates whether issuing of command using CMD line is allowed

13.3.3.4 Low-Level Programming Models

13.3.3.4.1 Surrounding Modules Global Initialization

This section identifies the requirements of initializing the surrounding modules when the module has to be used for the first time after a device reset. This initialization of surrounding modules is based on the integration and environment of the MMC/SD/SDIO modules.

Table 13-240. Global Init for Surrounding Modules

Surrounding Modules	Comments
PRCM	Module interface and functional clocks must be enabled. For more information, see , <i>Power, Reset, and Clock Management</i> .
Control module	Module-specific pad muxing and configuration must be set in the control module. See , <i>Control Module</i> .
(optional) MPU INTC	MPU INTC configuration must be done to enable the interrupts from the SD module. See , <i>Interrupts</i> .
(optional) EDMA	DMA configuration must be done to enable the module DMA channel requests. See , <i>EDMA</i> .
(optional) Interconnect	For more information about the interconnect configuration, see <i>Interconnects</i> .

Note

The MPU interrupt controller and the EDMA configurations are necessary, if the interrupt and DMA based communication modes are used.

13.3.3.4.2 MMC/SD/SDIO Controller Initialization Flow

The next sections outline the four steps to initialize the MMC/SD/SDIO controller:

- Initialize Clocks
- Software reset of the controller
- Set module's hardware capabilities
- Set module's Idle and Wake-Up modes

13.3.3.4.2.1 Enable OCP and CLKADPI Clocks

Prior to any SD register access one must enable the SD OCP clock and CLKADPI clock in PRCM module registers. For more information, see , *Power, Reset, and Clock Management*.

13.3.3.4.2.2 SD Soft Reset Flow

Figure 13-211 shows the soft reset process of MMC/SD/SDIO controller.

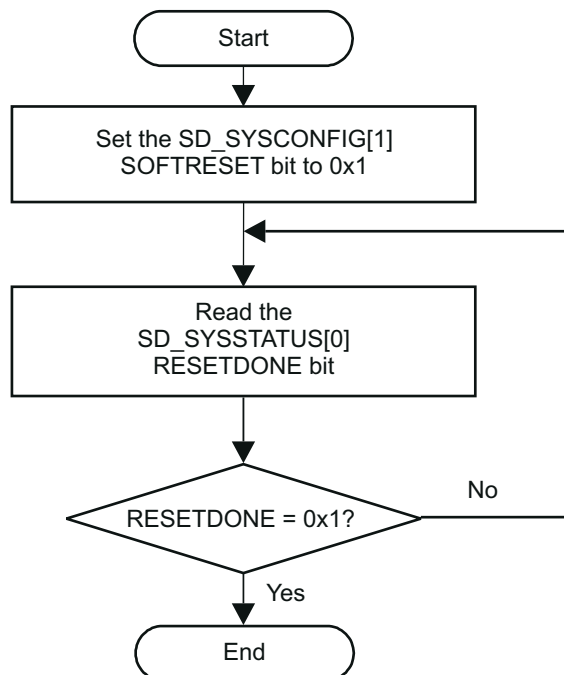

Figure 13-211. MMC/SD/SDIO Controller Software Reset Flow

13.3.3.4.2.3 Set SD Default Capabilities

Software must read capabilities (in boot ROM for instance) and is allowed to set (write) SD_CAPA[26:24] and SD_CUR_CAPA[23:0] registers before the MMC/SD/SDIO host driver is started.

13.3.3.4.2.4 Wake-Up Configuration

Table 13-241 details SD controller wake-up configuration.

Table 13-241. MMC/SD/SDIO Controller Wake-Up Configuration

Step	Access Type	Register/Bit Field/Programming Model
Configure wake-up bit (if necessary).	W	SD_SYSCONFIG[2] ENAWAKEUP
Enable wake-up events on SD card interrupt (if necessary).	W	SD_HCTL[24] IWE
SDIO Card only Enable card interrupt (if necessary).	W	SD_IE[8] CIRQENABLE

13.3.3.4.2.5 MMC Host and Bus Configuration

Figure 13-212 details the MMC bus configuration process.

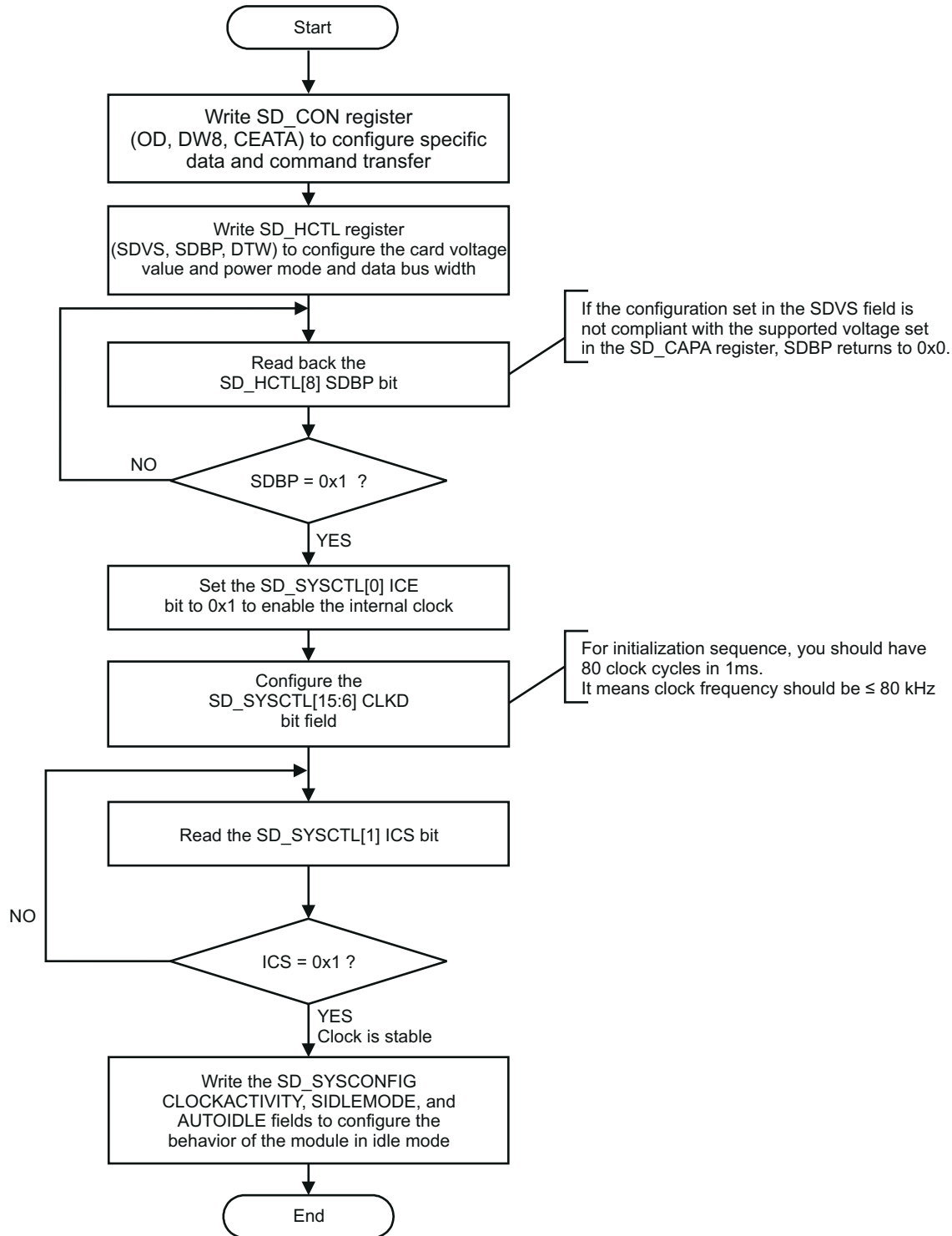

Figure 13-212. MMC/SD/SDIO Controller Bus Configuration Flow

13.3.3.4.3 Operational Modes Configuration

13.3.3.4.3.1 Basic Operations for MMC/SD/SDIO Host Controller

The MMC/SD/SDIO controller performs data transfers: data to card (referred to as write transfers) and data from card (referred to as read transfers).

The host controller requires transfers to run on a block-by-block basis, rather than on a DMA burst size basis. A single DMA request (or block request interrupt) is signaled for each block. Pipelining is supported as long as the block size is less than one half of the memory buffer size.

13.3.3.4.3.2 Card Detection, Identification, and Selection

Figure 13-213 and Figure 13-214 show the card identification and selection process.

ADVANCE INFORMATION

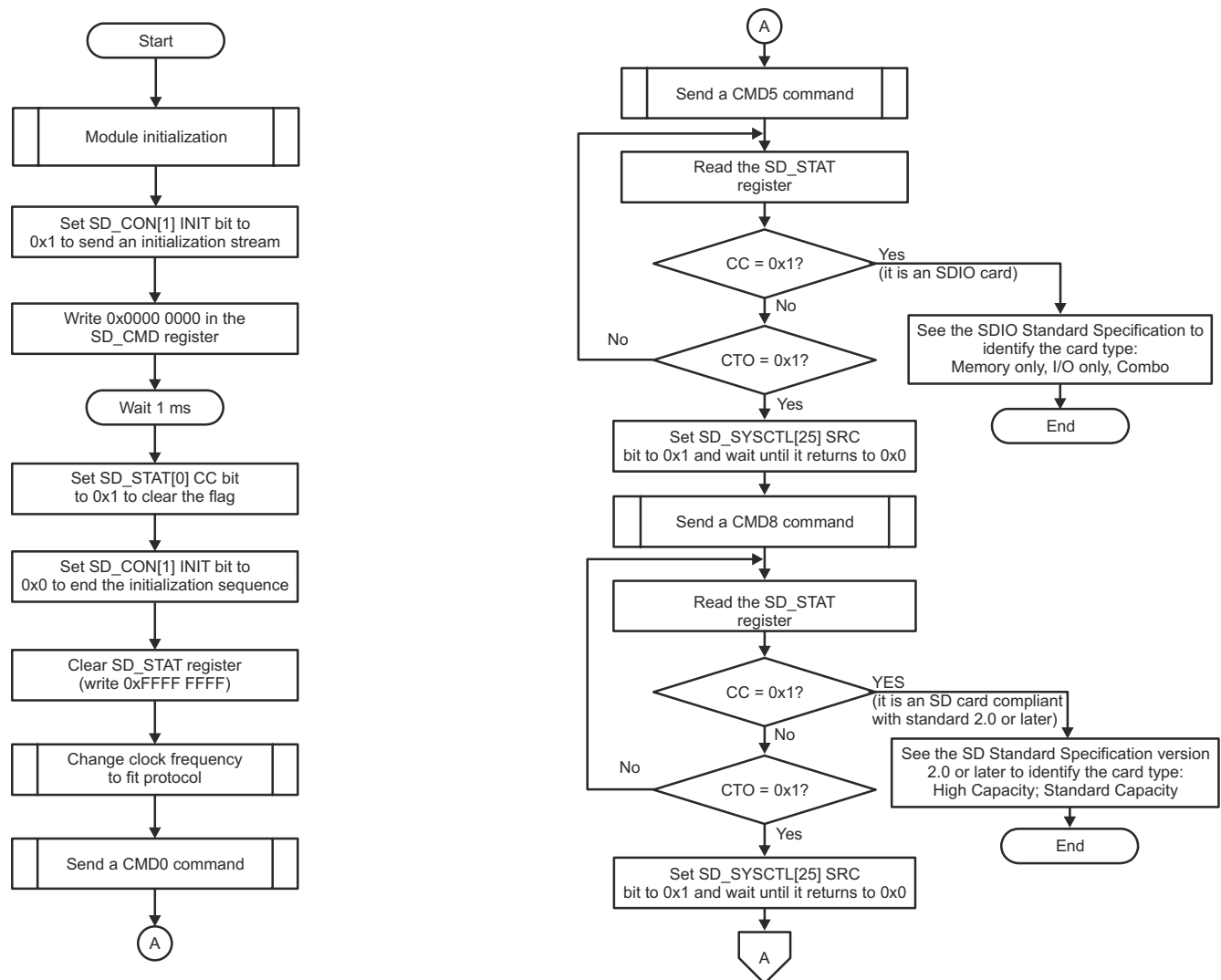
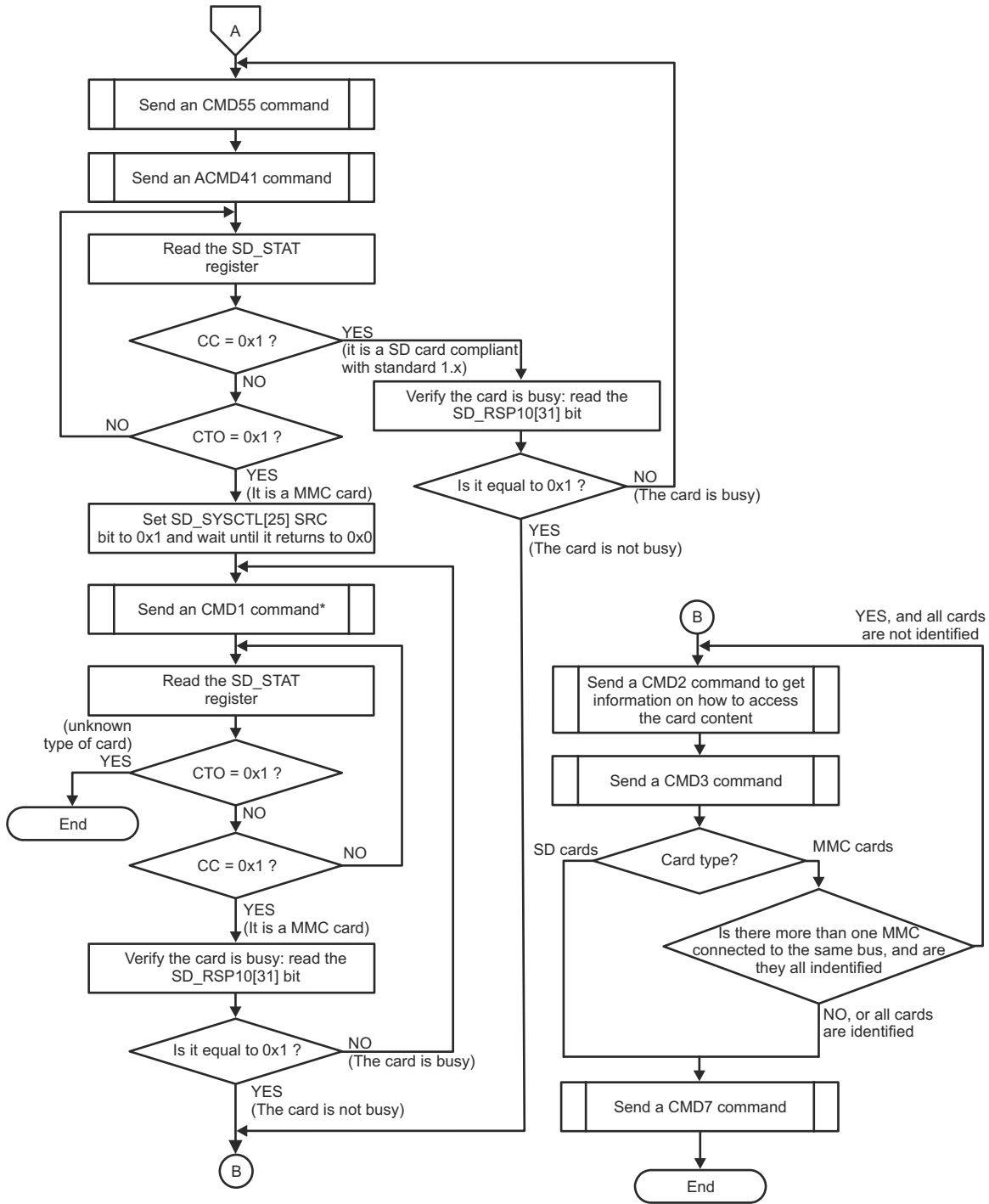

Figure 13-213. MMC/SD/SDIO Controller Card Identification and Selection - Part 1



*With OCR 0.

Figure 13-214. MMC/SD/SDIO Controller Card Identification and Selection - Part 2

13.3.4 Quad Serial Peripheral Interface (QSPI)

13.3.4.1 Quad Serial Peripheral Interface Overview.....	1327
13.3.4.2 QSPI Environment.....	1328
13.3.4.3 QSPI Integration.....	1329
13.3.4.4 QSPI Functional Description.....	1332

13.3.4.1 Quad Serial Peripheral Interface Overview

The quad serial peripheral interface (QSPI) module is a kind of SPI module that allows single, dual, or quad read access to external SPI devices. This module has a memory mapped register interface, which provides a direct interface for accessing data from external SPI devices and thus simplifying software requirements. The QSPI works as a controller only.

The one QSPI in the device is primarily intended for fast booting from quad-SPI flash memories. [Figure 13-215](#) shows the QSPI module overview.

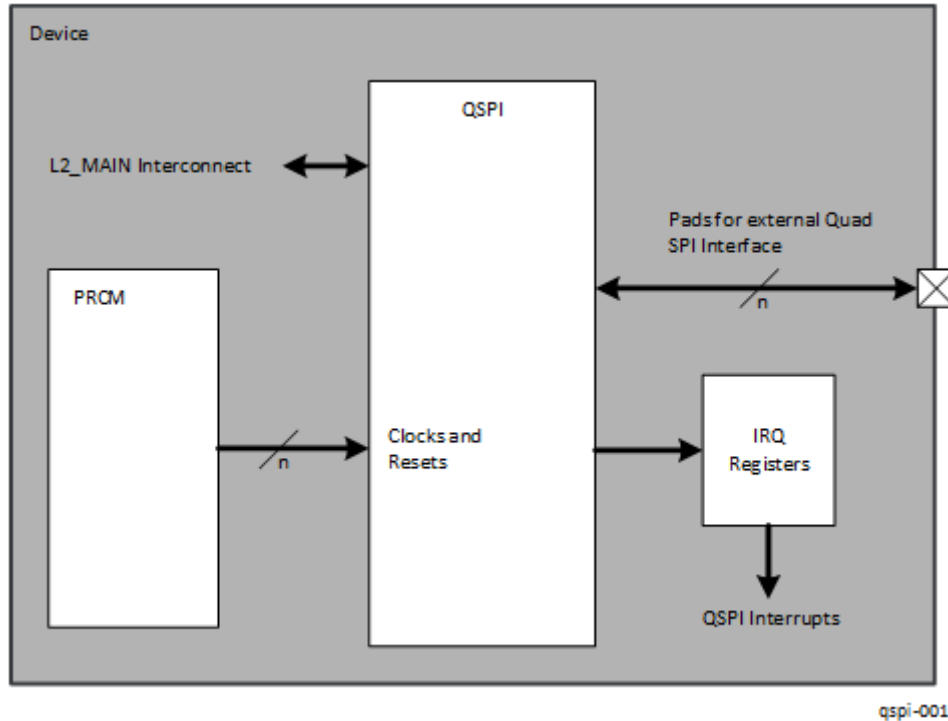

Figure 13-215. QSPI Overview

The QSPI supports the following features:

- General SPI features:
 - Programmable clock divider
 - Six pin interface
 - Programmable length (from 1 to 128 bits) of the words transferred
 - Programmable number (from 1 to 4096) of the words transferred
 - 2 external chip-select signal
 - Support for 3-, 4-, or 6-pin SPI interface
 - Optional interrupt generation on word or frame (number of words) completion
 - Programmable delay between chip select activation and output data from 0 to 3 QSPI clock cycles
 - Programmable signal polarities
 - Programmable active clock edge
 - Software-controllable interface allowing for any type of SPI transfer
 - Control through L2_MAIN configuration port
- Serial flash interface (SFI) features:
 - Serial flash read/write interface
 - Additional registers for defining read and write commands to the external serial flash device
 - 1 to 4 address bytes
 - Fast read support, where fast read requires dummy bytes after address bytes; 0 to 3 dummy bytes can be configured.

- Dual read support
- Quad read support
- Little-endian support (only for memory mapped registers used to configure QSPI controller and not SPI content accesses)
- Linear increment addressing mode only

The QSPI supports only dual and quad reads. Dual or quad writes are not supported. In addition, there is no "pass through" mode supported where the data present on the QSPI input is sent to its output.

Note

The QSPI module does not support cache line wrap mode.

Note

For information on how to select a flash memory to ensure correct operation please refer to the [AM263x QSPI Flash Selection Guide](#) Application Note

13.3.4.2 QSPI Environment

Figure 13-216 shows a typical connection of the QSPI module to the external quad-SPI flash memory.

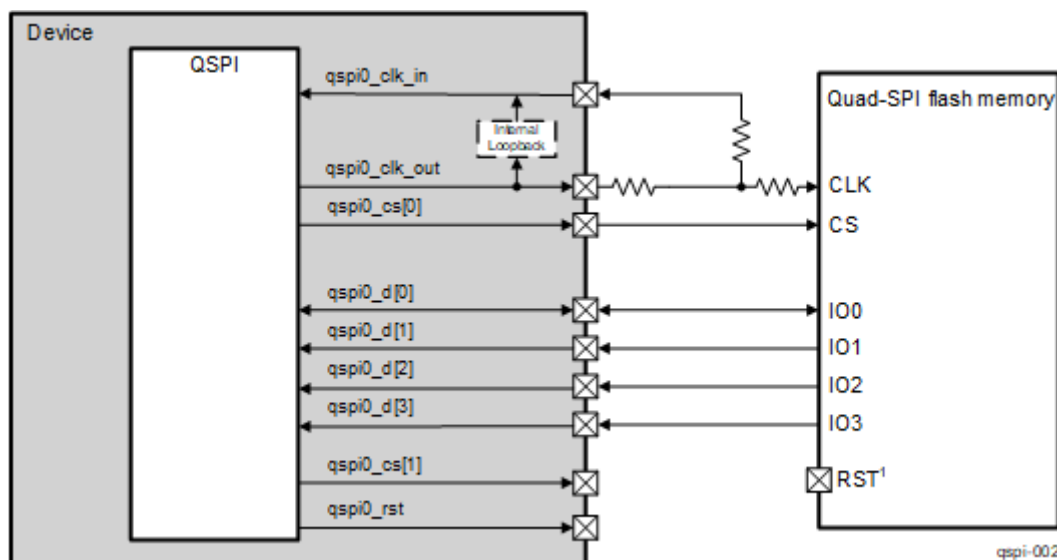

Figure 13-216. QSPI Connected to an External Quad-SPI Flash Memory

1. External flash memories that are larger than 128 Mb require an external reset pin for correct operation after SoC PORz reset. This reset must be triggered upon board reset to ensure the flash the flash is in the correct state upon boot.

Table 13-242 lists and describes the QSPI I/O signals.

Table 13-242. QSPI I/O Signals

QSPI Signal/Pad name	I/O ⁽¹⁾	Description					
		3-pin ⁽²⁾ SPI Read (Single Read)	3-pin ⁽²⁾ SPI Write (Single Write)	4-pin ⁽²⁾ SPI Read (Single Read)	4-pin ⁽²⁾ SPI Write (Single Write)	4-pin ⁽²⁾ SPI Read (Dual Read)	6-pin ⁽²⁾ SPI Read (Quad Read)
qspi0_d[0]	IO	Used as SPI data input	Used as SPI data output	Not used	Used as SPI data output	Used as SPI data input 0	Used as SPI data input 0
qspi0_d[1]	I	Not used	Not used	Used as SPI data input	Not used	Used as SPI data input 1	Used as SPI data input 1
qspi0_d[2]	I	Not used	Not used	Not used	Not used	Not used	Used as SPI data input 2

Table 13-242. QSPI I/O Signals (continued)

QSPI Signal/Pad name	I/O ⁽¹⁾	Description					
		3-pin ⁽²⁾ SPI Read (Single Read)	3-pin ⁽²⁾ SPI Write (Single Write)	4-pin ⁽²⁾ SPI Read (Single Read)	4-pin ⁽²⁾ SPI Write (Single Write)	4-pin ⁽²⁾ SPI Read (Dual Read)	6-pin ⁽²⁾ SPI Read (Quad Read)
qspi0_d[3]	I	Not used	Not used	Not used	Not used	Not used	Used as SPI data input 3
qspi0_sclk	O	Clock for the external SPI device					
qspi0_cs[0]	O	External SPI device chip-select 0					
qspi0_rtclk	I	The qspi0_sclk output must be connected to the qspi0_rtclk input, and is used for controlling the timing of the read return data when the QSPI module operates in Mode 0. In case Mode 3 is used, there is no need to connect the qspi0_sclk to the qspi0_rtclk.					

(1) I = Input; O = Output

(2) This is the pin count at the SPI flash memory side. The pin count at the device side is increased by one because of the qspi0_rtclk signal. References to the pin count throughout this chapter consider the pin count at the SPI flash memory side.

Note

In order to ensure proper timing, precise layout and routing requirements must be followed. For layout and routing requirements for all QSPI signals, see section “PCB Guidelines” of the device Data Manual.

13.3.4.3 QSPI Integration

This section describes module integration in the device, including information about clocks, resets, and hardware requests.

13.3.4.3.1 QSPI Integration (AM263x)

There is 1x QSPI module integrated in the device. The diagram below provides a visual representation of the device integration details.

ADVANCE INFORMATION

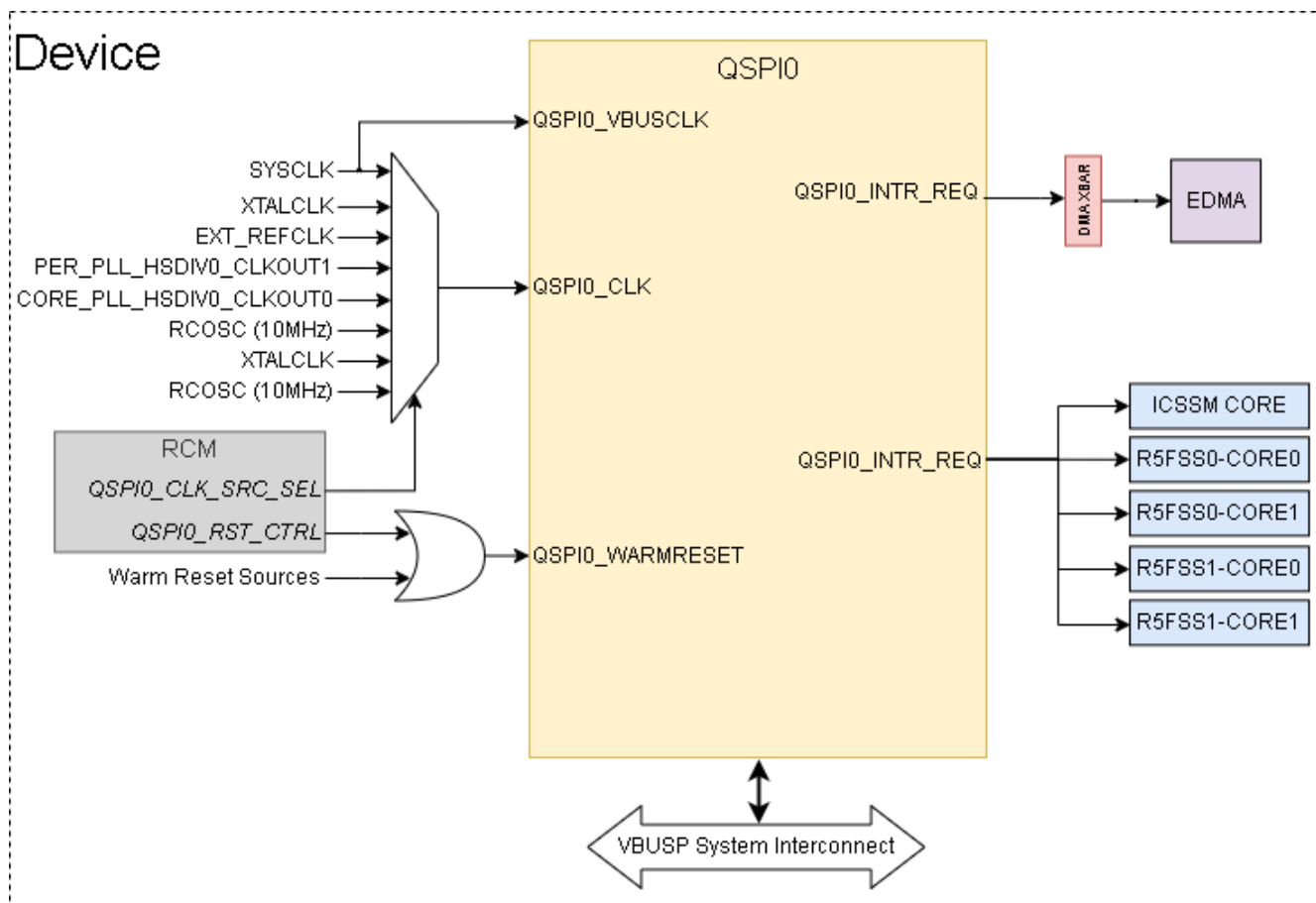

Figure 13-217. QSPI Integration Diagram

The tables below summarize the device integration details of QSPI.

Table 13-243. QSPI Device Integration

This table describes the module device integration details.

Module Instance	Device Allocation	SoC Interconnect
QSPI0	✓	VBUSM System Interconnect

Table 13-244. QSPI Clocks

This table describes the module clocking signals.

Module Instance	Module Clock Input	Source Clock Signal	Source	Default Freq	Description
QSPI0	QSPI0_ICLK (CLK)	SYS_CLK	PLL_CORE_CLK: HSDIV0_CLKOUT0	200 MHz	QSPI0 Interface Clock
	QSPI0_FCLK (SPI_CLK)	XTALCLK	External XTAL or RC Oscillator	25 MHz	QSPI0 Interface Clock
		EXT_REFCLK	External Reference Clock (EXT_REFCLK)	100 MHz	
		SYS_CLK	PLL_CORE_CLK: HSDIV0_CLKOUT0	200 MHz	
		DPLL_PER_HSDIV0_CLK OUT1	PLL_PER_CLK: HSDIV0_CLKOUT1	192 MHz	
		DPLL_CORE_HSDIV0_CL KOUT1	PLL_CORE_CLK: HSDIV0_CLKOUT1	400 MHz	
		RCCLK10M	Internal 10 MHz RC Oscillator (RCCLK10M)	10 MHz	
		XTALCLK	External XTAL	25 MHz	
		RCCLK10M	Internal 10 MHz RC Oscillator (RCCLK10M)	10 MHz	

Table 13-245. QSPI Resets

This table describes the module reset signals.

Module Instance	Module Reset Input	Source Reset Signal	Source	Description
QSPI0	QSPI0_RST (VBUSP_RSTn)	Warm Reset (MAIN_RST)	RCM + Warm Reset Sources	QSPI0 Asynchronous Reset

Table 13-246. QSPI Interrupt Requests

This table describes the module interrupt requests.

Module Instance	Module Interrupt Signal	Destination Interrupt Input	Destination	Type	Description
QSPI0	qspi0_intr	qspi0_intr_req	All R5FSS Cores ICSSM Core	Pulse	QSPI0 Interrupt

Table 13-247. QSPI DMA Requests

This table describes the module DMA requests.

Module Instance	Module DMA Event	Destination DMA Event Input	Destination	Type	Description
QSPI0	qspi0_intr	qspi0_intr_req	EDMA Crossbar (DMA_XBAR)	Pulse	QSPI0 DMA Event Request

Note

For more information on the interconnects, see the *System Interconnect* chapter.

For more information on power, reset, and clock management, see the corresponding sections within the *Device Configuration* chapter.

For more information on the device interrupt controllers, see the *Interrupt Controllers* chapter.

13.3.4.4 QSPI Functional Description

13.3.4.4.1 QSPI Block Diagram

Initial device boot from external SPI flash memory can be accomplished through the QSPI module. The interface is a simple 4-wire SPI used for control or data transfers. The QSPI also supports a 3-wire SPI protocol where the `qspi0_d[0]` signal is used as a bidirectional for reads and writes. In addition, a 6-wire mode can be used to support quad read devices. [Figure 13-218](#) shows the QSPI block diagram.

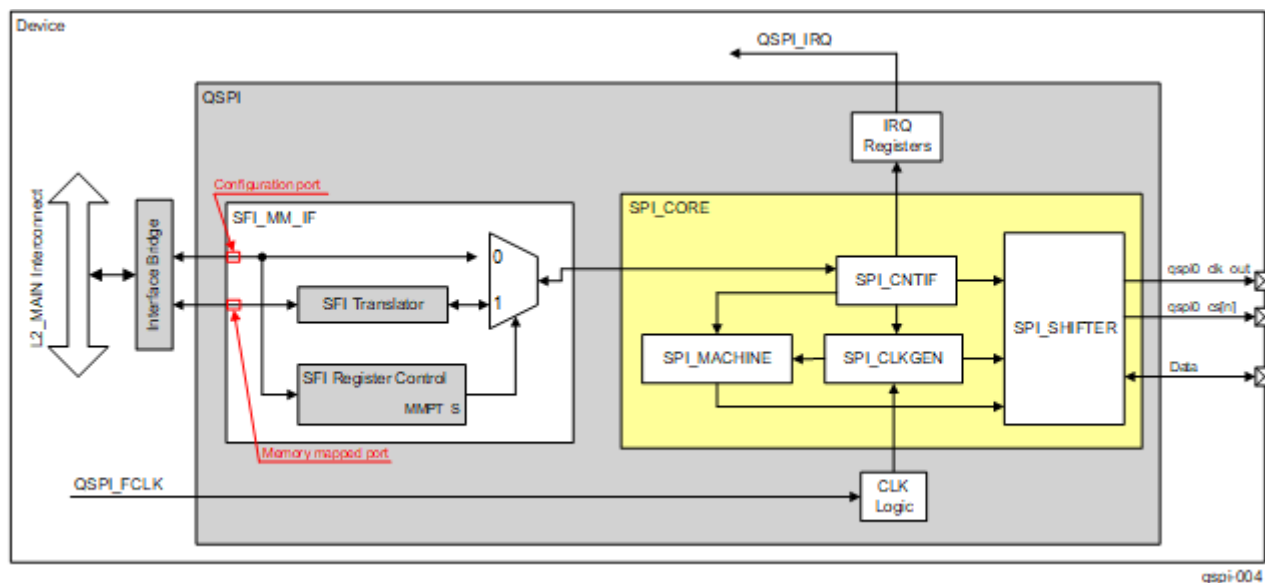

Figure 13-218. QSPI Block Diagram

The QSPI is composed of two blocks. The first one is the SFI memory-mapped interface (SFI_MM_IF) and the second one is the SPI core (SPI_CORE). The SFI_MM_IF block is associated only with SPI flash memories and is used for specifying typical for the SPI flash memories settings (read or write command, number of address and dummy bytes, and so on) unlike the SPI_CORE block, which is associated with the SPI interface itself and is used to configure typical SPI settings (chip-select polarity, serial clock inactive state, SPI clock mode, length of the words transferred, and so on).

The SFI_MM_IF comprises the following two subblocks:

- SFI register control
- SFI translator

The SPI_CORE comprises the following four subblocks:

- SPI control interface (SPI_CNTIF)
- SPI clock generator (SPI_CLKGEN)
- SPI control state machine (SPI_MACHINE)
- SPI data shifter (SPI_SHIFTER)

In addition, an interface bridge connects the two ports (configuration port and memory-mapped port) of the SFI_MM_IF block to the L2_MAIN interconnect. There are no software controls associated with this interface bridge.

The QSPI supports long transfers through a frame-style sequence. In its generic SPI use mode, a word can be defined up to 128 bits and multiple words can be transferred during a single access. For each word, a device initiator must read or write the new data and then tell the QSPI to continue the current operation. Using this sequence, a maximum of 4096 128-bit words can be transferred in a single SPI read or write operation. This allows great flexibility when connecting the QSPI to various types of devices.

As opposed to the generic SPI use mode, the communication with serial flash-type devices requires sending a byte command, followed by sending bytes of data. Commands can be sent through the SPI_CORE block to

communicate with a serial flash device; however, it is easier to do this using the SFI_MM_IF block because it is intended to ease the communication with serial flash devices. If the SPI_CORE is used to communicate with a serial flash device, software must load the command into the SPI data transfer register with additional configuration fields, perform the byte transfer, then place the data to be sent (or configure for receive) along with additional configuration fields, and perform that transfer. Reads and writes to serial flash devices are more specific. First, the read or write command byte is sent, followed by 1 to 4 bytes of address (corresponding to the address to read/write), then followed by the data write/receive phase. Data is always sent byte oriented. When the address is loaded, data can be continuously read or written, and the address will automatically increment to each byte address internally to the serial flash device.

Note

The SFI_MM_IF block only allows reading and writing to an externally connected SPI flash device. The SFI_MM_IF block does not allow reads or writes to internal configuration and status registers of the SPI flash device. These registers must be accessed through the features of the SPI_CORE block.

13.3.4.4.1.1 SFI Register Control

The SFI register control block consists of the following five configuration registers:

- QSPI_SPI_SETUP0_REG
- QSPI_SPI_SETUP1_REG
- QSPI_SPI_SETUP2_REG
- QSPI_SPI_SETUP3_REG
- QSPI_SPI_SWITCH_REG

The first four registers let the user define the following:

- Byte command for a serial flash read specified by the QSPI_SPI_SETUP_i_REG[7:0] RCMD bit field
- Byte command for a serial flash write specified by the QSPI_SPI_SETUP_i_REG[23:16] WCMD bit field
- Number of address bytes required for the particular type of serial flash specified by the QSPI_SPI_SETUP_i_REG[9:8] NUM_A_BYTES bit field
- Number of "dummy bytes" that may be needed to support the fast read mode function of some serial flash devices. The QSPI_SPI_SETUP_i_REG[11:10] NUM_D_BYTES bit field specifies the number of "dummy bits." In addition, the QSPI_SPI_SETUP_i_REG[28:24] NUM_D_BITS bit field can also specify the number of "dummy bits."
- Whether the read command is single (normal), dual, or quad read mode command. This is specified by the QSPI_SPI_SETUP_i_REG[13:12] READ_TYPE bit field. (*i* is equal to 0, 1, 2 and 3 and means that the QSPI_SPI_SETUP_i_REG registers are associated with each of the four supported chip-selects [that is, four supported output SPI flash devices])

The QSPI_SPI_SWITCH_REG register acts as a static switch which allows the configuration port (shown in [Figure 13-218](#)) to connect directly to the SPI_CORE block, or allows the memory-mapped port (also shown in [Figure 13-218](#)) to connect to the SPI_CORE block. This is done using the QSPI_SPI_SWITCH_REG[0] MMPT_S bit.

In addition, the QSPI_SPI_SWITCH_REG[1] MM_INT_EN bit is used to enable or disable the word complete interrupt during operations using the memory-mapped port.

13.3.4.4.1.2 SFI Translator

The SFI translator block represents an FSM which, based on the configuration information loaded into the SFI register control block, converts each input read/write sequence into an SPI_CORE configuration sequence for access to the external serial flash memory.

A read sequence is converted into the following actions:

1. SPI chip-select goes active.
2. Read command byte is issued.
3. 1 to 4 address bytes, which correspond to the first address supplied, are issued.
4. 0 to 3 dummy bytes are issued, if "fast read" is supported.
5. Data bytes are read from the external SPI flash memory.

6. SPI chip-select goes inactive.

For linear addressing mode, action 5 is repeated until the byte count to be transferred reaches zero.

A write sequence is identical to a read sequence, except that a write sequence does not use dummy bytes.

Another important aspect with regard to writes is that a serial flash memory location can only be written to if the bits are erased in advance. Erased means the bits are set to 1. This means that writing only changes 1 contents to 0. It is not possible with this write to change the contents of a bit from 0 to 1. An erase command must be performed to do this operation. Erase commands cannot be executed on single byte locations. Depending on device types, there are page, block, and chip erase commands. To perform an erase command, the particular command must be sent over the SPI bus, and an internal register of the serial flash device must then be polled to determine when the erase completes. The erases must be done through the configuration port by software before performing any writes through the memory-mapped port. This means that writes are passed through to the serial flash device, but if the memory locations being modified are not properly erased before the write, the contents may not result in what was sent.

13.3.4.4.1.3 SPI Control Interface

The SPI control interface contains configuration registers used to configure the SPI core functionality of the QSPI. This block maintains all configuration settings for the SPI core (that is, settings specific for the SPI interface itself but not for the SPI flash memories).

The registers defined for this block are:

- The QSPI_PID register, which is read only and contains QSPI revision associated information
- The QSPI_SPI_CLOCK_CNTRL_REG register, which is used to control external SPI clock (qspi0_sclk)
- The QSPI_SPI_DC_REG register used to define the SPI clock mode and chip-select polarity for the four external SPI devices
- The QSPI_SPI_CMD_REG register used to control the operation of the SPI command. This register is also used to configure and transfer data.
- Four data registers used for reading the data received and for writing the data to be transferred. These registers are:
 - QSPI_SPI_DATA_REG
 - QSPI_SPI_DATA_REG_1
 - QSPI_SPI_DATA_REG_2
 - QSPI_SPI_DATA_REG_3

These four registers compose a 128-bit shift register.

- The QSPI_SPI_STATUS_REG register, which contains status information

All of these registers can only be written if the QSPI is not busy. This means that they can be written if the QSPI_SPI_STATUS_REG[0] BUSY bit is 0x0. The QSPI becomes busy when a write to the QSPI_SPI_CMD_REG[18:16] CMD bit field is performed. Writing to this bit field starts an SPI transaction and sets the QSPI_SPI_STATUS_REG[0] BUSY bit to 0x1. The CMD bit field can be written again when the BUSY bit is 0x0. In addition, the start of the SPI transaction is synchronized to the qspi0_sclk clock and clearing of the BUSY bit is synchronized to the QSPI_FCLK clock.

The register group QSPI_SPI_DATA_REG_3, QSPI_SPI_DATA_REG_2, QSPI_SPI_DATA_REG_1 and QSPI_SPI_DATA_REG is treated as a single 128-bit word for shifting data in and out. The QSPI_SPI_DATA_REG_3 register is used for the most significant bits and the QSPI_SPI_DATA_REG is used for the least significant bits. This applies for both reads and writes. For example, after reading a 128-bit word (WLEN = 0x7F) the most significant bit of the data read, that is bit 127, will be located at QSPI_SPI_DATA_REG_3[31] position and the least significant bit, that is bit 0 of the data read, will be located at the QSPI_SPI_DATA_REG[0] position.

The data written to this register group should be right justified so that a data pre-shifting is not required. The QSPI_SPI_CMD_REG[25:19] WLEN bit field determines the location of the most significant bit and the bit position that will be shifted out first during a write. In order to shift out byte data the WLEN bit field should be set to 0x7 and the data byte should be written to the lower byte of the QSPI_SPI_DATA_REG register. By setting the word length to 0x7 the QSPI_SPI_DATA_REG register will look like a pseudo 8-bit shift register. When the

user wants to write 40-bit long word the WLEN bit field should be set to 0x27, the 32 least significant bits of data should be written to the QSPI_SPI_DATA_REG and the rest 8 most significant bits of data should be written to the lower byte of the QSPI_SPI_DATA_REG_1 register. By setting WLEN to 0x27 these two registers will look like a pseudo 40-bit shift register. When the word length is greater than 64 bits the QSPI_SPI_DATA_REG_2 register is also used and the previously described logic applies. The QSPI_SPI_DATA_REG_3 register is used together with the other three data registers when the word length is greater than 96 bits.

When dual or quad read mode is used the number of the words transferred must be even. This number is configured through the QSPI_SPI_CMD_REG[11:0] FLEN bit field.

Note

The QSPI module does not support a "pass through" mode where the data present on qspi0_d[1] is sent to qspi0_d[0], when 4-pin non-dual read mode is used. This means that setting the QSPI_SPI_CMD_REG[18:16] CMD bit field to 0x1 causes the QSPI only to read from an external device using the qspi0_d[1] pad as an input and if a write to the same external device is desired, the CMD bit field should be set to 0x2, which causes the qspi0_d[0] pad to be used as an output.

13.3.4.4.1.4 SPI Clock Generator

The SPI clock generator uses the QSPI_FCLK clock as an input, and generates the qspi0_sclk, which is a divided version of the QSPI_FCLK clock. The divide ratio is a 16-bit value configured through the QSPI_SPI_CLOCK_CNTRL_REG[15:0] DCLK_DIV bit field and thus provides a division factor in a range from 1 to 65536. The QSPI_FCLK clock is divided by the DCLK_DIV value + 1 to provide the qspi0_sclk clock. When DCLK_DIV = 0x0 the QSPI_FCLK clock equals the DCLK clock. The value in the DCLK_DIV bit field applies only when the QSPI_SPI_CLOCK_CNTRL_REG[31] CLKEN bit is set to 0x1. Figure 13-219 shows the SPI_CLKGEN block.

If the CLKEN bit is 0x0 the command specified in the QSPI_SPI_CMD_REG[18:16] CMD bit field is not executed and the QSPI_SPI_STATUS_REG[0] BUSY bit is not set. The command is executed only if the CLKEN bit is 0x1 before write to the CMD bit field.

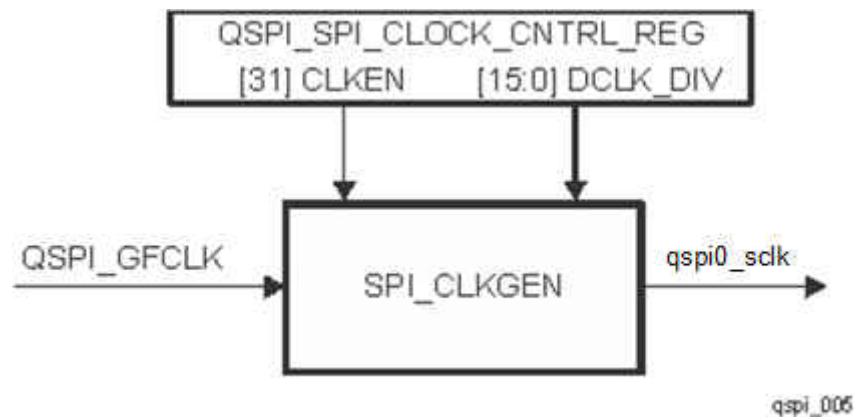

Figure 13-219. SPI_CLKGEN Block

13.3.4.4.1.5 SPI Control State-Machine

The SPI control state-machine (SPI_MACHINE) manages the operation of the SPI_CORE block. SPI_MACHINE takes control and configuration information from the registers in the SPI_CNTIF block as input and provides control information to the SPI data shifter. This information is used to control the SPI data port. The SPI_MACHINE also generates status information, which is sent back to the SPI_CNTIF block.

Writing a valid value to the QSPI_SPI_CMD_REG[18:16] CMD bit field sets immediately the QSPI_SPI_STATUS_REG[0] BUSY bit to 0x1, activates the corresponding qspi0_cs[n] (n = 0 to 1) and starts the SPI data transaction. The BUSY bit is cleared automatically when QSPI_SPI_CMD_REG[25:19] WLEN number of bits are shifted in or out. If the value of the QSPI_SPI_STATUS_REG@[27:16] WDCNT bit field is different

than 0x0 and WLEN number of bits are shifted already, the SPI_MACHINE waits until another write to the CMD bit field is performed. If the command written to the CMD bit field is valid, then this increments the value of the WDCNT bit field from 0x0 and starts shifting data in or out again. This is repeated until the WDCNT bit field reaches the frame length (QSPI_SPI_CMD_REG[11:0] FLEN), that is, all words of the frame are shifted or till earlier frame termination occurs. While the SPI_MACHINE is waiting for write to the CMD bit field the corresponding qspi0_cs[n] (n = 0 to 1) remains active and the BUSY flag is set to 0x0. In addition, the bit length for each word can be changed during a frame from 1 to 128 bits using the QSPI_SPI_CMD_REG[25:19] WLEN bit field.

The SPI_MACHINE also provides a mechanism to terminate the frame earlier. This is done by writing an invalid command to the CMD bit field. An invalid command corresponds to the 0x0 and 0x4 (reserved) values of the CMD bit field. Writing one of these values when the the WDCNT bit field is not equal to 0x0 and when the BUSY flag is 0x0 terminates the frame earlier.

The corresponding qspi0_cs[n] (n = 0 to 1) becomes inactive when all words are shifted or when the frame terminates earlier.

13.3.4.4.1.6 SPI Data Shifter

The SPI data shifter handles the capture and generation of the SPI interface signals. Based on control signals from the SPI_MACHINE and SPI_CNTIF blocks, data is shifted in or out on falling or rising edge of qspi0_sclk clock depending on the SPI clock mode selected. [Table 13-248](#) lists the four defined clock modes of operation for the QSPI.

Table 13-248. SPI Clock Modes Definition

Mode	Settings in the QSPI_SPI_DC_REG Register		Description
	Value of the CKP bits	Value of the CKPH bits	
0	0	0	Data input captured on falling edge of qspi0_sclk clock. Data output generated on falling edge of qspi0_sclk clock
1	0	1	Data input captured on rising edge of qspi0_sclk clock. Data output generated on rising edge of qspi0_sclk clock
2	1	0	Data input captured on rising edge of qspi0_sclk clock. Data output generated on rising edge of qspi0_sclk clock
3	1	1	Data input captured on falling edge of qspi0_sclk clock. Data output generated on falling edge of qspi0_sclk clock

Note

Mode 1 and Mode 2 are not supported and should not be used.

The CKPi and CKPHi (i = 0 to 3) bits of the QSPI_SPI_DC_REG register control the clock modes. Each of these 4 bits corresponds to an output chip select.

[Figure 13-220](#) shows all four clock modes. In addition, through the DDi (i = 0 to 3) bits of the QSPI_SPI_DC_REG register the data can be delayed from one to three qspi0_sclk clock cycles after the corresponding qspi0_cs[n] (n = 0 to 1) goes active. The active state of each chip-select can also be controlled through the CSPi (i = 0 to 3) bits of the QSPI_SPI_DC_REG register.

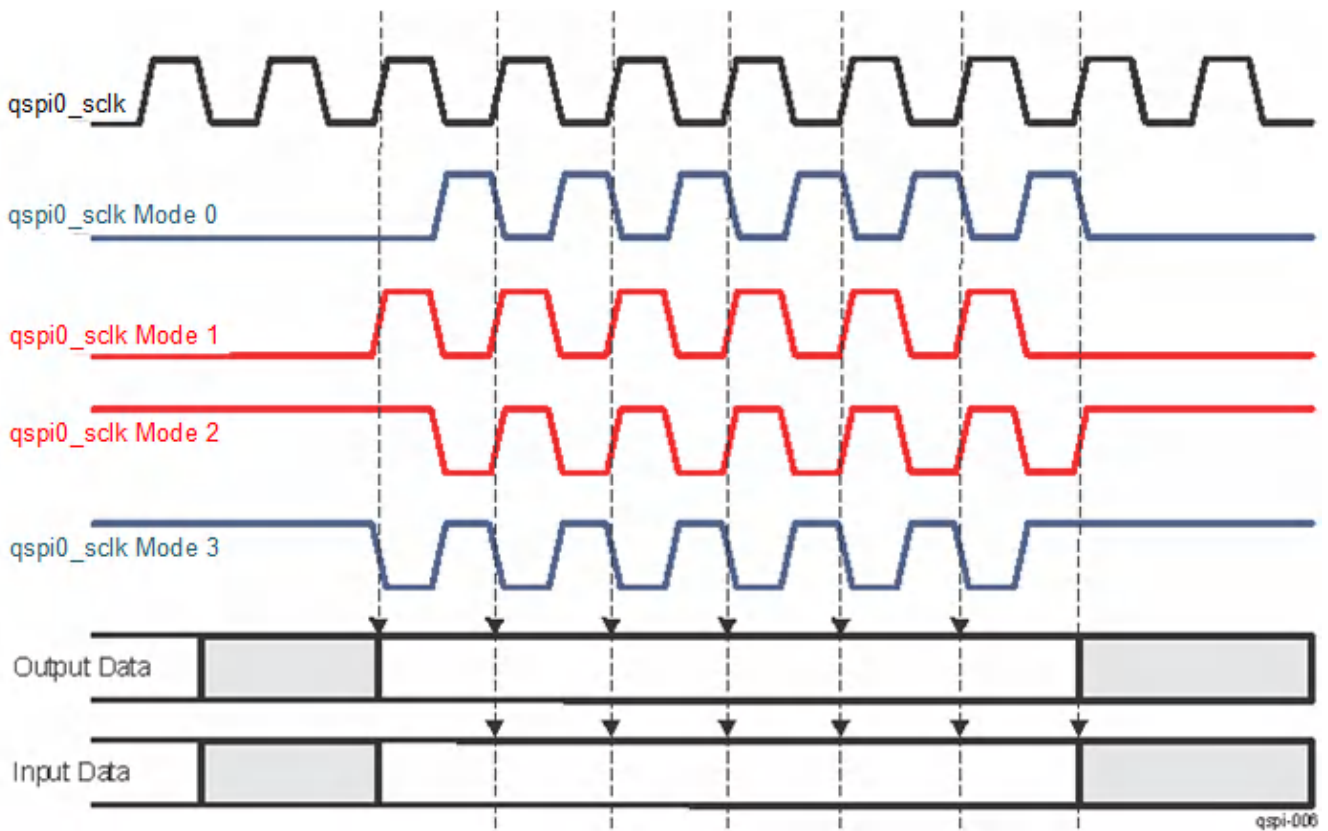

Figure 13-220. SPI Clock Modes

13.3.4.4.2 QSPI Interrupt Requests

Figure 13-221 shows a logical representation of the QSPI interrupt generation scheme.

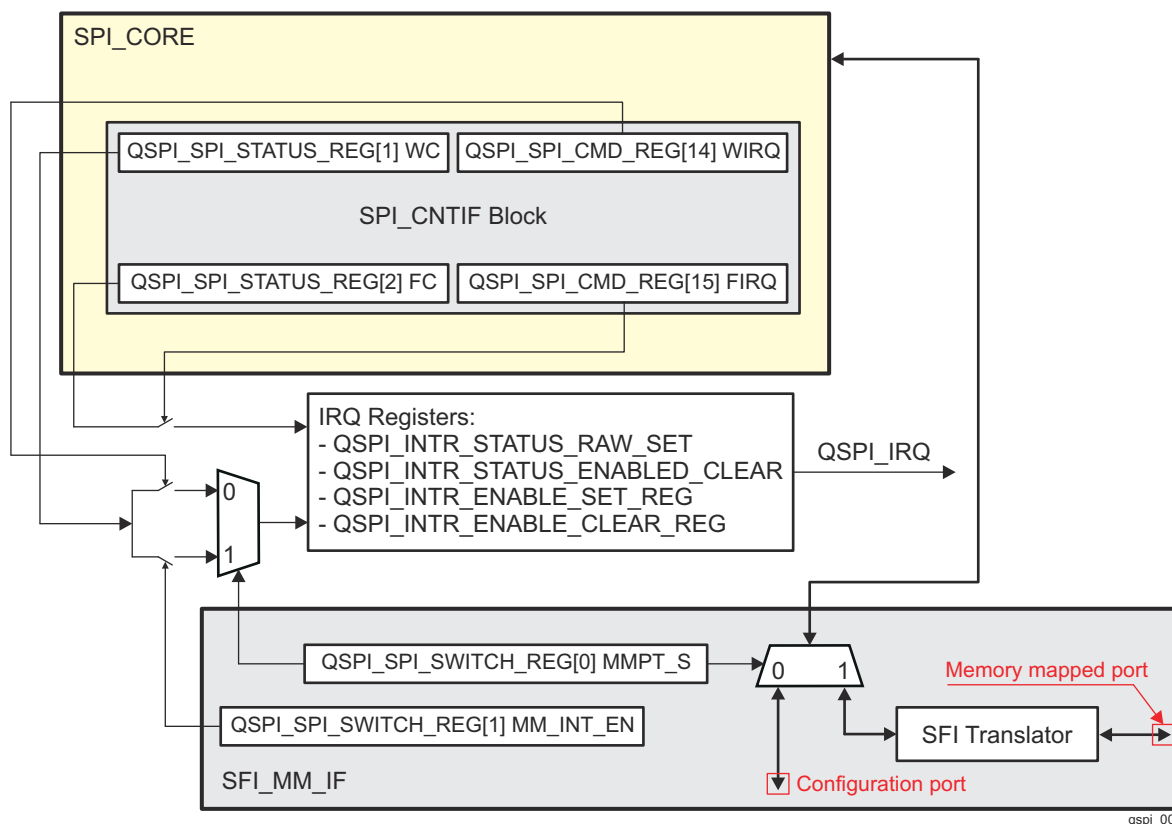

Figure 13-221. Logical Representation of the QSPI Interrupt Generation Scheme

QSPI_SPI_STATUS_REG[1] WC and QSPI_SPI_STATUS_REG[2] FC are status bits indicating whether word or frame transfer is complete. Setting the corresponding interrupt enable bit (WIRQ or FIRQ) in the QSPI_SPI_CMD_REG register allows these events (WC and FC) to generate an interrupt. The WC and FC bits are reset every time the user writes to the QSPI_SPI_CMD_REG register or reads the QSPI_SPI_STATUS_REG register. This is done to keep control parameters from changing the interface protocol signals while a transfer is in progress. Additionally, the QSPI_SPI_SWITCH_REG[1] MM_INT_EN bit is used to enable or disable the word complete interrupt during operations using the memory-mapped port.

When the QSPI_SPI_CMD_REG[14] WIRQ and QSPI_SPI_CMD_REG[15] FIRQ bits are set to 0x1 the following applies:

- The QSPI activates its interrupt line only if the interrupts are enabled by setting to 0x1 the corresponding bits in the QSPI_INTR_ENABLE_SET_REG register. These interrupts can be disabled by setting the corresponding bits in the QSPI_INTR_ENABLE_CLEAR_REG register to 0x1.
- After an interrupt has been serviced, software must clear the corresponding status flag. This is done by setting the corresponding bit in the QSPI_INTR_STATUS_ENABLED_CLEAR register to 0x1, which also clears the corresponding bit in the QSPI_INTR_STATUS_RAW_SET register. The status flags in the QSPI_INTR_STATUS_RAW_SET register are set even if the corresponding interrupt is disabled unlike those in the QSPI_INTR_STATUS_ENABLED_CLEAR register, which are set only if the corresponding interrupt is enabled.
- The QSPI also generates an interrupt if a certain bit in the QSPI_INTR_STATUS_RAW_SET register is set to 0x1 and the corresponding interrupt is enabled through the QSPI_INTR_ENABLE_SET_REG register. This feature is useful during user software debugging. In addition, even if interrupts are not enabled a corresponding raw flag in the QSPI_INTR_STATUS_RAW_SET register is set to 0x1 when an IRQ condition occurs.
- Even if interrupts are not enabled, a certain status bit in the QSPI_INTR_STATUS_RAW_SET register can also be cleared by setting to 0x1 the corresponding bit in the QSPI_INTR_STATUS_ENABLED_CLEAR register.

It must be considered that the previously described scenario applies if the QSPI_SPI_CMD_REG[14] WIRQ and QSPI_SPI_CMD_REG[15] FIRQ bits are set to 0x1.

Note

The QSPI_IRQ interrupt line is activated only if at least one of the following conditions is met:

- The word complete interrupt is enabled:
 - during operations using the memory-mapped port by setting to 0x1 both the QSPI_SPI_SWITCH_REG[1] MM_INT_EN and QSPI_INTR_ENABLE_SET_REG[1] WIRQ_ENA_SET bits.
 - during operations using the configuration port by setting to 0x1 both the QSPI_SPI_CMD_REG[14] WIRQ and QSPI_INTR_ENABLE_SET_REG[1] WIRQ_ENA_SET bits.
- The frame complete interrupt is enabled setting to 0x1 both the QSPI_SPI_CMD_REG[15] FIRQ and QSPI_INTR_ENABLE_SET_REG[0] FIRQ_ENA_SET bits.

The QSPI_IRQ interrupt line is also activated when both the conditions are met.

Table 13-249 lists the event flags and the corresponding mask bits of the sources which can cause interrupts.

Table 13-249. QSPI Events

Event Flag	Event Mask	Description
QSPI_INTR_STATUS_RAW_SET[1] WIRQ_RAW QSPI_INTR_STATUS_ENABLED_CLEAR[1] WIRQ_ENA QSPI_SPI_STATUS_REG[1] WC	QSPI_INTR_ENABLE_SET_REG[1] WIRQ_ENA_SET QSPI_INTR_ENABLE_CLEAR_REG[1] WIRQ_ENA_CLR QSPI_SPI_CMD_REG[14] WIRQ	Word complete interrupt event. Asserted each time after a word is transferred or received.
QSPI_INTR_STATUS_RAW_SET[0] FIRQ_RAW QSPI_INTR_STATUS_ENABLED_CLEAR[0] FIRQ_ENA QSPI_SPI_STATUS_REG[2] FC	QSPI_INTR_ENABLE_SET_REG[0] FIRQ_ENA_SET QSPI_INTR_ENABLE_CLEAR_REG[0] FIRQ_ENA_CLR QSPI_SPI_CMD_REG[15] FIRQ	Frame complete interrupt event. Asserted each time after a frame is transferred or received.

Note

QSPI_IRQ can also be used to trigger DMA events

13.3.4.4.3 QSPI Memory Regions

Two memory regions are associated with the QSPI. The first memory region is dedicated to the configuration port. Using this memory region, all internal registers can be programmed and serial transfers made from the supported external SPI devices. The L2_MAIN start address at which the configuration port is available is 0x4820 0000. The second memory region is associated mainly with the memory-mapped port and is used for communication directly with one of the two supported external SPI devices. The memory region for device 1 starts at 0x6000 0000 and the memory region for device 2 starts at 0x6200 0000

It is important to keep in mind that the configuration port provides an access to all the QSPI registers listed in the register summary. These are configuration registers and also four data registers. The configuration registers are used to configure typical SPI and serial flash memory settings and the four data registers are used for read and write operations. When communicating with an external SPI device (but not an SPI flash memory) the SPI_CORE module should be used and the data exchanged is available through these four data registers, which can be accessed only through the configuration port.

13.4 Industrial and Control Interfaces

This section describes the industrial and control interfaces in the device.

13.4.1 Modular Controller Area Network (MCAN)	1341
13.4.2 Local Interconnect Network (LIN)	1388

13.4.1 Modular Controller Area Network (MCAN)

This section describes the Modular Controller Area Network (MCAN) modules in the device.

13.4.1.1 MCAN Overview

The Controller Area Network (CAN) is a serial communications protocol which efficiently supports distributed real-time control. CAN has high immunity to electrical interference. In a CAN network, many short messages are broadcast to the entire network, which provides for data consistency in every node of the system.

The MCAN module supports both classic CAN and CAN FD (CAN with Flexible Data-Rate) specifications. CAN FD feature allows high throughput and increased payload per data frame. The classic CAN and CAN FD devices can coexist on the same network without any conflict.

The device supports 4 MCAN modules:

They connect to the physical layer of the CAN network through external (for the device) transceivers. Each MCAN module supports flexible bit rates and is compliant to ISO 11898-1:2015.

13.4.1.1.1 MCAN Features

Each MCAN module implements the following features:

- Conforms with CAN Protocol 2.0 A, B and ISO 11898-1:2015
- Full CAN FD support (up to 64 data bytes)
- SAE J1939 support
- AUTOSAR support
- Up to 32 dedicated Transmit Buffers
- Configurable Transmit FIFO, up to 32 elements
- Configurable Transmit Queue, up to 32 elements
- Configurable Transmit Event FIFO, up to 32 elements
- Up to 64 dedicated Receive Buffers
- Two configurable Receive FIFOs, up to 64 elements each
- Up to 128 filter elements
- Internal Loopback mode for self-test
- Maskable interrupts, two interrupt lines
- Two clock domains (CAN clock/Host clock)
- Parity/ECC support - Message RAM single error correction and double error detection (SECEDED) mechanism
- Local power-down and wakeup support
- Timestamp Counter

13.4.1.1.2 MCAN Not Supported Features

- Host Bus Firewall
- GPIO Mode
- Clock Calibration
- External (IO) Loopback Mode
- Debug DMA (see [Section 13.4.1.4.7.4](#))
- TX DMA Channels [31:4]

13.4.1.2 MCAN Environment

This section describes the MCAN external connections (environment).

CAN network physical layer consists of two-wire differential bus, usually twisted pair, and provides high level of interference immunity. External CAN transceiver IC is needed to access a CAN bus by the MCAN.

Figure 13-222 shows the MCAN typical application.

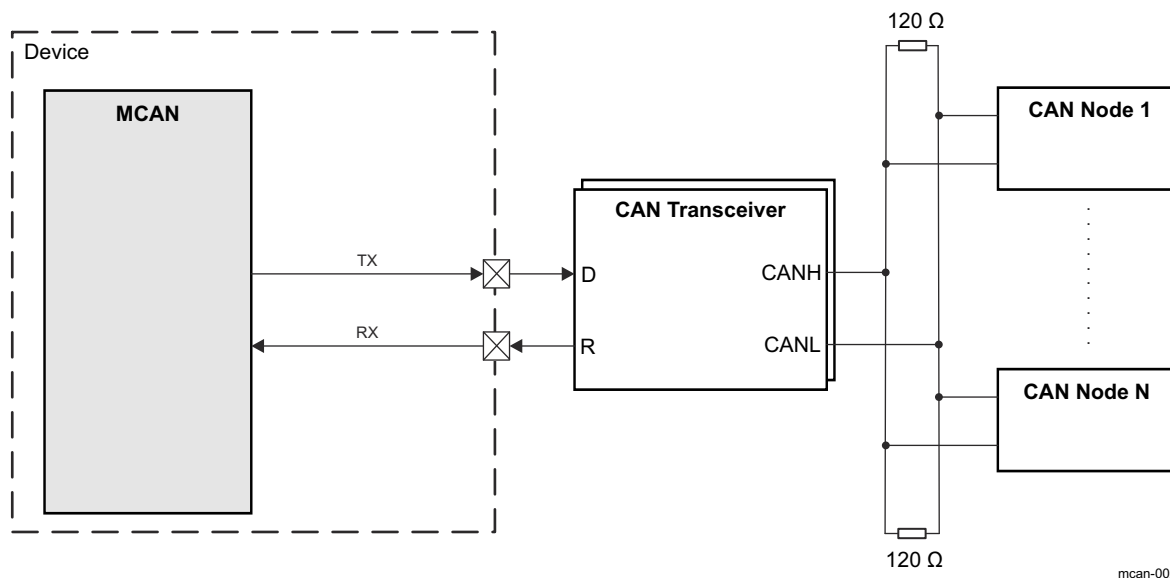

Figure 13-222. MCAN Typical Application

Table 13-250 describes the MCAN I/O signals.

Table 13-250. MCAN I/O Signals

Module Pin	Device Level Signal	I/O ⁽¹⁾	Description	Module Pin Reset Value ⁽¹⁾
RX	MCAN0_RX	I	Serial data input from external CAN transceiver	HiZ
TX	MCAN0_TX	O	Serial data output to external CAN transceiver	1
RX	MCAN1_RX	I	Serial data input from external CAN transceiver	HiZ
TX	MCAN1_TX	O	Serial data output to external CAN transceiver	1

(1) I = Input; O = Output; HiZ = High Impedance

Note

For more information about device level signals (pull-up/down resistors, buffer type, multiplexing and others), see tables Pin Attributes and Pin Multiplexing in the device-specific Datasheet.

13.4.1.2.1 CAN Network Basics

- CAN bus is a 2-wire differential bus using Non-Return-to-Zero (NRZ) encoding and has two states:
 - Recessive state (logical 1)
 - Dominant state (logical 0)
- The network is multicontroller. When two or more nodes (ECUs) attempt to transmit at the same time, a non-destructive arbitration technique guarantees messages are sent in order of priority and no messages are lost.
- The message transmission is multicast. Data messages transmitted are identifier based, not address based.
- Content of message is labeled by the identifier that is unique throughout the network (for example: rpm, temperature, position, pressure, and so forth).
- All nodes on network receive the message and each performs an acceptance test on the identifier. If message is relevant, it is processed, otherwise it is ignored.
- The unique identifier also determines the priority of the message (the lower the numerical value of the identifier, the higher the priority is).
- Data is transmitted and received using message frames, consisting of the following basic fields:
 - Arbitration field
 - Control field
 - Data field (up to 8 bytes for Classical CAN and up to 64 bytes for CAN FD)
 - CRC field
 - ACK field

For more information, see *ISO 11898-1:2015: CAN data link layer and physical signaling*.

13.4.1.3 MCAN Integration

This section describes the MCAN integration in the device, including information about clocks, resets, and hardware requests.

13.4.1.3.1 MCAN Integration

There are 4x MCAN modules integrated in the device. The diagram below provides a visual representation of the device integration details.

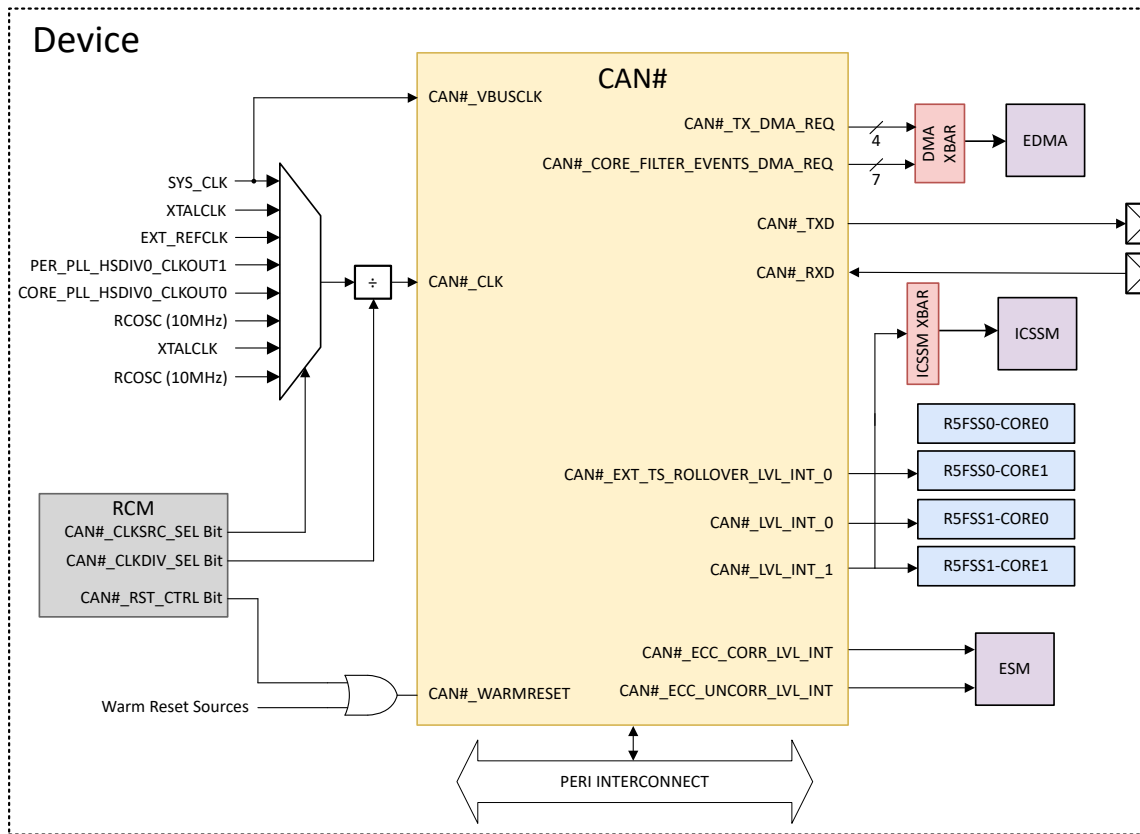

Figure 13-223. MCAN Integration Diagram

The tables below summarize the device integration details of MCAN# (where # = 0 to 3).

Table 13-251. MCAN Device Integration

This table describes the module device integration details.

Module Instance	Device Allocation	SoC Interconnect
MCAN0	✓	Peripheral VBUSP Interconnect
MCAN1	✓	Peripheral VBUSP Interconnect
MCAN2	✓	Peripheral VBUSP Interconnect
MCAN3	✓	Peripheral VBUSP Interconnect

Table 13-252. MCAN Clocks

This table describes the module clocking signals.

Module Instance	Module Clock Input	Source Clock Signal	Source	Default Freq	Description
MCAN0	MCAN0_ICLK (VBUSP_CLK)	SYS_CLK	PLL_CORE_CLK:HSDIV0_CLKOUT0	200 MHz	MCAN0 Interface Clock
	MCAN0_FCLK (CAN_CLK)	XTALCLK	External Crystal (XTAL)	25 MHz	MCAN0 Functional Clock
		EXT_REFCLK	External Reference Clock(EXT_REFCLK)	100 MHz	
		SYS_CLK	PLL_CORE_CLK:HSDIV0_CLKOUT0	200 MHz	
		DPLL_PER_HSDIV0_CLKOUT1	PLL_PER_CLK:HSDIV0_CLKOUT1	192 MHz	
		DPLL_CORE_HSDIV0_CLKOUT0	PLL_CORE_CLK:HSDIV0_CLKOUT1	500 MHz	
		RCCLK10M	Internal 10 MHz RC Oscillator(RCCLK10M)	10 MHz	
		XTALCLK	External Crystal (XTAL)	25 MHz	
		RCCLK10M	Internal 10 MHz RC Oscillator(RCCLK10M)	10 MHz	
MCAN1	MCAN1_ICLK (VBUSP_CLK)	SYS_CLK	PLL_CORE_CLK:HSDIV0_CLKOUT0	200 MHz	MCAN1 Interface Clock
	MCAN1_FCLK (CAN_CLK)	XTALCLK	External Crystal (XTAL)	25 MHz	MCAN1 Functional Clock
		EXT_REFCLK	External Reference Clock(EXT_REFCLK)	100 MHz	
		SYS_CLK	PLL_CORE_CLK:HSDIV0_CLKOUT0	200 MHz	
		DPLL_PER_HSDIV0_CLKOUT1	PLL_PER_CLK:HSDIV0_CLKOUT1	192 MHz	
		DPLL_CORE_HSDIV0_CLKOUT0	PLL_CORE_CLK:HSDIV0_CLKOUT1	500 MHz	
		RCCLK10M	Internal 10 MHz RC Oscillator(RCCLK10M)	10 MHz	
		XTALCLK	External Crystal (XTAL)	25 MHz	
		RCCLK10M	Internal 10 MHz RC Oscillator(RCCLK10M)	10 MHz	

Table 13-252. MCAN Clocks (continued)

This table describes the module clocking signals.

Module Instance	Module Clock Input	Source Clock Signal	Source	Default Freq	Description
MCAN2	MCAN2_ICLK (VBUSP_CLK)	SYS_CLK	PLL_CORE_CLK:HSDIV0_CLKOUT0	200 MHz	MCAN2 Interface Clock
	MCAN2_FCLK (CAN_CLK)	XTALCLK	External Crystal (XTAL)	25 MHz	MCAN2 Functional Clock
		EXT_REFCLK	External Reference Clock(EXT_REFCLK)	100 MHz	
		SYS_CLK	PLL_CORE_CLK:HSDIV0_CLKOUT0	200 MHz	
		DPLL_PER_HSDIV0_CLKOUT1	PLL_PER_CLK:HSDIV0_CLKOUT1	192 MHz	
		DPLL_CORE_HSDIV0_CLKOUT0	PLL_CORE_CLK:HSDIV0_CLKOUT1	500 MHz	
		RCCLK10M	Internal 10 MHz RC Oscillator(RCCLK10M)	10 MHz	
		XTALCLK	External Crystal (XTAL)	25 MHz	
		RCCLK10M	Internal 10 MHz RC Oscillator(RCCLK10M)	10 MHz	
MCAN3	MCAN3_ICLK (VBUSP_CLK)	SYS_CLK	PLL_CORE_CLK:HSDIV0_CLKOUT0	200 MHz	MCAN3 Interface Clock
	MCAN3_FCLK (CAN_CLK)	XTALCLK	External Crystal (XTAL)	25 MHz	MCAN3 Functional Clock
		EXT_REFCLK	External Reference Clock(EXT_REFCLK)	100 MHz	
		SYS_CLK	PLL_CORE_CLK:HSDIV0_CLKOUT0	200 MHz	
		DPLL_PER_HSDIV0_CLKOUT1	PLL_PER_CLK:HSDIV0_CLKOUT1	192 MHz	
		DPLL_CORE_HSDIV0_CLKOUT0	PLL_CORE_CLK:HSDIV0_CLKOUT1	500 MHz	
		RCCLK10M	Internal 10 MHz RC Oscillator(RCCLK10M)	10 MHz	
		XTALCLK	External Crystal (XTAL)	25 MHz	
		RCCLK10M	Internal 10 MHz RC Oscillator(RCCLK10M)	10 MHz	

Table 13-253. MCAN Resets

This table describes the module reset signals.

Module Instance	Module Reset Input	Source Reset Signal	Source	Description
MCAN0	MCAN0_RST	Warm Reset (MOD_G_RST)	RCM + Warm Reset Sources	Asynchronous MCAN0 Module Reset
MCAN1	MCAN1_RST	Warm Reset (MOD_G_RST)	RCM + Warm Reset Sources	Asynchronous MCAN1 Module Reset
MCAN2	MCAN2_RST	Warm Reset (MOD_G_RST)	RCM + Warm Reset Sources	Asynchronous MCAN2 Module Reset
MCAN3	MCAN3_RST	Warm Reset (MOD_G_RST)	RCM + Warm Reset Sources	Asynchronous MCAN3 Module Reset

Table 13-254. MCAN Interrupt Requests

This table describes the module interrupt requests.

Module Instance	Module Interrupt Signal	Destination Interrupt Input	Destination	Type	Description	
MCAN0	MCAN0_INT_0	R5FSS0_CORE0_INTR_IN_27	R5FSS0-0	Level	MCAN0 Line 0 Interrupt Request	
		R5FSS0_CORE1_INTR_IN_27	R5FSS0-1			
		R5FSS1_CORE0_INTR_IN_27	R5FSS1-0			
		R5FSS1_CORE1_INTR_IN_27	R5FSS1-1			
		PRU_ICSS0_INTR_IN_40	PRU_ICSS			
	MCAN0_INT_1	MCAN0_INT_1	R5FSS0_CORE0_INTR_IN_28	R5FSS0-0	Level	MCAN0 Line 1 Interrupt Request
			R5FSS0_CORE1_INTR_IN_28	R5FSS0-1		
			R5FSS1_CORE0_INTR_IN_28	R5FSS1-0		
			R5FSS1_CORE1_INTR_IN_28	R5FSS1-1		
			PRU_ICSS0_INTR_IN_41	PRU_ICSS		
	MCAN0_EXT_TS_ROLLOVER_INT_0	MCAN0_EXT_TS_ROLLOVER_INT_0	R5FSS0_CORE0_INTR_IN_26	R5FSS0-0	Level	MCAN0 External TimeStamp Counter Rollover Interrupt
			R5FSS0_CORE1_INTR_IN_26	R5FSS0-1		
			R5FSS1_CORE0_INTR_IN_26	R5FSS1-0		
			R5FSS1_CORE1_INTR_IN_26	R5FSS1-1		
			PRU_ICSS0_INTR_IN_39	PRU_ICSS0		
	MCAN0_ECC_CORR_LVL_INT_0	ESM0_LVL_IN_2	ESM0	Level	MCAN0 ECC Correctable Error Interrupt	
	MCAN0_ECC_UNCORR_LVL_INT_0	ESM0_LVL_IN_3	ESM0	Level	MCAN0 ECC Uncorrectable Error Interrupt	
	MCAN1	MCAN1_INT_0	R5FSS0_CORE0_INTR_IN_30	R5FSS0-0	Level	MCAN1 Line 0 Interrupt Request
			R5FSS0_CORE1_INTR_IN_30	R5FSS0-1		
			R5FSS1_CORE0_INTR_IN_30	R5FSS1-0		
R5FSS1_CORE1_INTR_IN_30			R5FSS1-1			
PRU_ICSS0_INTR_IN_43			PRU_ICSS			
MCAN1_INT_1		MCAN1_INT_1	R5FSS0_CORE0_INTR_IN_31	R5FSS0-0	Level	MCAN1 Line 1 Interrupt Request
			R5FSS0_CORE1_INTR_IN_31	R5FSS0-1		
			R5FSS1_CORE0_INTR_IN_31	R5FSS1-0		
			R5FSS1_CORE1_INTR_IN_31	R5FSS1-1		
			PRU_ICSS0_INTR_IN_44	PRU_ICSS		
MCAN1_EXT_TS_ROLLOVER_INT_0		MCAN1_EXT_TS_ROLLOVER_INT_0	R5FSS0_CORE0_INTR_IN_29	R5FSS0-0	Level	MCAN1 External TimeStamp Counter Rollover Interrupt
			R5FSS0_CORE1_INTR_IN_29	R5FSS0-1		
			R5FSS1_CORE0_INTR_IN_29	R5FSS1-0		
			R5FSS1_CORE1_INTR_IN_29	R5FSS1-1		
			PRU_ICSS0_INTR_IN_42	PRU_ICSS		
MCAN1_ECC_UNCORR_LVL_INT_0		ESM0_LVL_IN_4	ESM0	Level	MCAN1 ECC Uncorrectable Error Interrupt	
MCAN1_ECC_CORR_LVL_INT_0		ESM0_LVL_IN_5	ESM0	Level	MCAN1 ECC Correctable Error Interrupt	

Table 13-254. MCAN Interrupt Requests (continued)

This table describes the module interrupt requests.

Module Instance	Module Interrupt Signal	Destination Interrupt Input	Destination	Type	Description	
MCAN2	MCAN2_INT_0	R5FSS0_CORE1_INTR_IN_33	R5FSS0-0	Level	MCAN1 Line 0 Interrupt Request	
		R5FSS0_CORE1_INTR_IN_33	R5FSS0-1			
		R5FSS1_CORE0_INTR_IN_33	R5FSS1-0			
		R5FSS1_CORE1_INTR_IN_33	R5FSS1-1			
		PRU_ICSS0_INTR_IN_46	PRU_ICSS			
	MCAN2_INT_1	R5FSS0_CORE0_INTR_IN_34	R5FSS0-0	Level	MCAN2 Line 1 Interrupt Request	
		R5FSS0_CORE1_INTR_IN_34	R5FSS0-1			
		R5FSS1_CORE0_INTR_IN_34	R5FSS1-0			
		R5FSS1_CORE1_INTR_IN_34	R5FSS1-1			
		PRU_ICSS0_INTR_IN_47	PRU_ICSS			
	MCAN2_EXT_TS_ROLLOVER_INT_0	R5FSS0_CORE0_INTR_IN_32	R5FSS0-0	Level	MCAN2 External TimeStamp Counter Rollover Interrupt	
		R5FSS0_CORE1_INTR_IN_32	R5FSS0-1			
		R5FSS1_CORE0_INTR_IN_32	R5FSS1-0			
		R5FSS1_CORE1_INTR_IN_32	R5FSS1-1			
		PRU_ICSS0_INTR_IN_45	PRU_ICSS			
	MCAN2_ECC_UNCORR_LVL_INT_0	ESM0_LVL_IN_6	ESM0	Level	MCAN2 ECC Uncorrectable Error Interrupt	
	MCAN2_ECC_CORR_LVL_INT_0	ESM0_LVL_IN_7	ESM0	Level	MCAN2 ECC Correctable Error Interrupt	
	MCAN3	MCAN3_INT_0	R5FSS0_CORE0_INTR_IN_36	R5FSS0-0	Level	MCAN3 Line 0 Interrupt Request
			R5FSS0_CORE1_INTR_IN_36	R5FSS0-1		
			R5FSS1_CORE0_INTR_IN_36	R5FSS1-0		
R5FSS1_CORE1_INTR_IN_36			R5FSS1-1			
PRU_ICSS0_INTR_IN_49			PRU_ICSS			
MCAN3_INT_1		R5FSS0_CORE0_INTR_IN_37	R5FSS0-0	Level	MCAN3 Line 1 Interrupt Request	
		R5FSS0_CORE1_INTR_IN_37	R5FSS0-1			
		R5FSS1_CORE0_INTR_IN_37	R5FSS1-0			
		R5FSS1_CORE1_INTR_IN_37	R5FSS1-1			
		PRU_ICSS0_INTR_IN_50	PRU_ICSS			
MCAN3_EXT_TS_ROLLOVER_INT_0		R5FSS0_CORE0_INTR_IN_35	R5FSS0-0	Level	MCAN3 External TimeStamp Counter Rollover Interrupt	
		R5FSS0_CORE1_INTR_IN_35	R5FSS0-1			
		R5FSS1_CORE0_INTR_IN_35	R5FSS1-0			
		R5FSS1_CORE1_INTR_IN_35	R5FSS1-1			
		PRU_ICSS0_INTR_IN_48	PRU_ICSS			
MCAN3_ECC_UNCORR_LVL_INT_0		ESM0_LVL_IN_8	ESM0	Level	MCAN3 ECC Uncorrectable Error Interrupt	
MCAN3_ECC_CORR_LVL_INT_0		ESM0_LVL_IN_9	ESM0	Level	MCAN3 ECC Correctable Error Interrupt	

Table 13-255. MCAN0 DMA Requests

This table describes the module DMA requests.

Module Instance	Module DMA Event	Destination DMA Event Input	Destination	Type	Description
MCAN0	MCAN0_FE_INTR_0	EDMA_XBAR_147	EDMA	Pulse	MCAN0 Receive Filter Event 0 DMA Request
	MCAN0_FE_INTR_1	EDMA_XBAR_148	EDMA	Pulse	MCAN0 Receive Filter Event 1 DMA Request
	MCAN0_FE_INTR_2	EDMA_XBAR_149	EDMA	Pulse	MCAN0 Receive Filter Event 2 DMA Request
	MCAN0_FE_INTR_3	EDMA_XBAR_150	EDMA	Pulse	MCAN0 Receive Filter Event 3 DMA Request
	MCAN0_FE_INTR_4	EDMA_XBAR_151	EDMA	Pulse	MCAN0 Receive Filter Event 4 DMA Request
	MCAN0_FE_INTR_5	EDMA_XBAR_152	EDMA	Pulse	MCAN0 Receive Filter Event 5 DMA Request
	MCAN0_FE_INTR_6	EDMA_XBAR_153	EDMA	Pulse	MCAN0 Receive Filter Event 6 DMA Request
	MCAN0_TXDMA_0	EDMA_XBAR_74	EDMA	Pulse	MCAN0 Transmit Core DMA Request 0
	MCAN0_TXDMA_1	EDMA_XBAR_75	EDMA	Pulse	MCAN0 Transmit Core DMA Request 1
	MCAN0_TXDMA_2	EDMA_XBAR_76	EDMA	Pulse	MCAN0 Transmit Core DMA Request 2
	MCAN0_TXDMA_3	EDMA_XBAR_77	EDMA	Pulse	MCAN0 Transmit Core DMA Request 3

Table 13-255. MCAN DMA Requests (continued)

This table describes the module DMA requests.

Module Instance	Module DMA Event	Destination DMA Event Input	Destination	Type	Description
MCAN1	MCAN1_FE_INTR_0	EDMA_XBAR_154	EDMA	Pulse	MCAN1 Receive Filter Event 0 DMA Request
	MCAN1_FE_INTR_1	EDMA_XBAR_155	EDMA	Pulse	MCAN1 Receive Filter Event 1 DMA Request
	MCAN1_FE_INTR_2	EDMA_XBAR_156	EDMA	Pulse	MCAN1 Receive Filter Event 2 DMA Request
	MCAN1_FE_INTR_3	EDMA_XBAR_157	EDMA	Pulse	MCAN1 Receive Filter Event 3 DMA Request
	MCAN1_FE_INTR_4	EDMA_XBAR_158	EDMA	Pulse	MCAN1 Receive Filter Event 4 DMA Request
	MCAN1_FE_INTR_5	EDMA_XBAR_159	EDMA	Pulse	MCAN1 Receive Filter Event 5 DMA Request
	MCAN1_FE_INTR_6	EDMA_XBAR_160	EDMA	Pulse	MCAN1 Receive Filter Event 6 DMA Request
	MCAN1_TXDMA_0	EDMA_XBAR_78	EDMA	Pulse	MCAN1 Transmit Core DMA Request 0
	MCAN1_TXDMA_1	EDMA_XBAR_79	EDMA	Pulse	MCAN1 Transmit Core DMA Request 1
	MCAN1_TXDMA_2	EDMA_XBAR_80	EDMA	Pulse	MCAN1 Transmit Core DMA Request 2
	MCAN1_TXDMA_3	EDMA_XBAR_81	EDMA	Pulse	MCAN1 Transmit Core DMA Request 3

Table 13-255. MCAN DMA Requests (continued)

This table describes the module DMA requests.

Module Instance	Module DMA Event	Destination DMA Event Input	Destination	Type	Description
MCAN2	MCAN2_FE_INTR_0	EDMA_XBAR_161	EDMA	Pulse	MCAN2 Receive Filter Event 0 DMA Request
	MCAN2_FE_INTR_1	EDMA_XBAR_162	EDMA	Pulse	MCAN2 Receive Filter Event 1 DMA Request
	MCAN2_FE_INTR_2	EDMA_XBAR_163	EDMA	Pulse	MCAN2 Receive Filter Event 2 DMA Request
	MCAN2_FE_INTR_3	EDMA_XBAR_164	EDMA	Pulse	MCAN2 Receive Filter Event 3 DMA Request
	MCAN2_FE_INTR_4	EDMA_XBAR_165	EDMA	Pulse	MCAN2 Receive Core Filter Event 4 DMA Request
	MCAN2_FE_INTR_5	EDMA_XBAR_166	EDMA	Pulse	MCAN2 Receive Filter Event 5 DMA Request
	MCAN2_FE_INTR_6	EDMA_XBAR_167	EDMA	Pulse	MCAN2 Receiver Filter Event 6 DMA Request
	MCAN2_TXDMA_0	EDMA_XBAR_82	EDMA	Pulse	MCAN2 Transmit Core DMA Request 0
	MCAN2_TXDMA_1	EDMA_XBAR_83	EDMA	Pulse	MCAN2 Transmit Core DMA Request 1
	MCAN2_TXDMA_2	EDMA_XBAR_84	EDMA	Pulse	MCAN2 Transmit Core DMA Request 2
	MCAN2_TXDMA_3	EDMA_XBAR_85	EDMA	Pulse	MCAN2 Transmit Core DMA Request 3

Table 13-255. MCAN DMA Requests (continued)

This table describes the module DMA requests.

Module Instance	Module DMA Event	Destination DMA Event Input	Destination	Type	Description
MCAN3	MCAN3_FE_INTR_0	EDMA_XBAR_168	EDMA	Pulse	MCAN3 Receive Filter Event 0 DMA Request
	MCAN3_FE_INTR_1	EDMA_XBAR_169	EDMA	Pulse	MCAN3 Receive Filter Event 1 DMA Request
	MCAN3_FE_INTR_2	EDMA_XBAR_170	EDMA	Pulse	MCAN3 Receive Filter Event 2 DMA Request
	MCAN3_FE_INTR_3	EDMA_XBAR_171	EDMA	Pulse	MCAN3 Receive Filter Event 3 DMA Request
	MCAN3_FE_INTR_4	EDMA_XBAR_172	EDMA	Pulse	MCAN3 Receive Filter Event 4 DMA Request
	MCAN3_FE_INTR_5	EDMA_XBAR_173	EDMA	Pulse	MCAN3 Receive Filter Event 5 DMA Request
	MCAN3_FE_INTR_6	EDMA_XBAR_174	EDMA	Pulse	MCAN3 Receive Filter Event 6 DMA Request
	MCAN3_TXDMA_0	EDMA_XBAR_86	EDMA	Pulse	MCAN3 Transmit Core DMA Request 0
	MCAN3_TXDMA_1	EDMA_XBAR_87	EDMA	Pulse	MCAN3 Transmit Core DMA Request 1
	MCAN3_TXDMA_2	EDMA_XBAR_88	EDMA	Pulse	MCAN3 Transmit Core DMA Request 2
	MCAN3_TXDMA_3	EDMA_XBAR_89	EDMA	Pulse	MCAN3 Transmit Core DMA Request 3

Note

For more information on the interconnects, see the *System Interconnect* chapter.

For more information on power, reset, and clock management, see the corresponding sections within the *Device Configuration* chapter.

For more information on the device interrupt controllers, see the *Interrupt Controllers* chapter.

13.4.1.4 MCAN Functional Description

The MCAN module performs CAN protocol communication according to ISO 11898-1:2015. The bit rate can be programmed to values greater than 1 Mbps. Additional transceiver hardware is required for the connection to the physical layer (CAN bus).

For communication on a CAN network, individual message frames can be configured. The message frames and identifier masks are stored in the Message RAM.

All functions concerning the handling of messages are implemented in the Message Handler.

The register set of the MCAN module can be accessed directly via the module interface. These registers are used to control and configure the CAN core and the Message Handler, and to access the Message RAM.

Figure 13-224 shows the MCAN module block diagram.

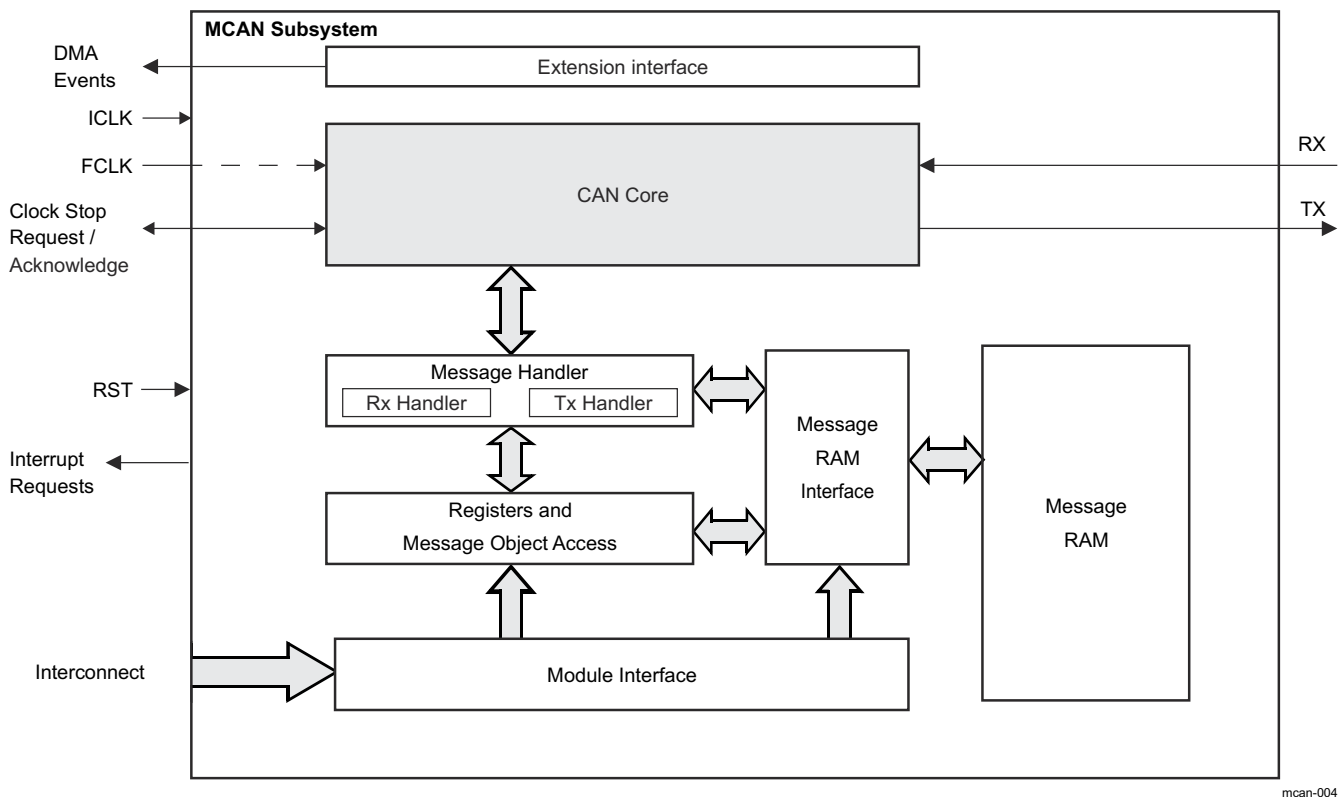

Figure 13-224. MCAN Block Diagram

The MCAN module blocks description:

- **CAN Core:** the CAN core consists of the CAN protocol controller and the Rx/Tx shift register. It handles all ISO 11898-1:2015 protocol functions and supports 11-bit and 29-bit identifiers.
- **Message Handler:** the Message Handler (Rx Handler and Tx Handler) is a state machine that controls the data transfer between the single-ported Message RAM and the CAN core's Rx/Tx shift register. It also handles the acceptance filtering and the Interrupt/DMA request generation as programmed in the control registers.
- **Message RAM:** the main purpose of the Message RAM is to store Rx/Tx messages, Tx Event elements, and Message ID Filter elements (for more information, see [Section 13.4.1.4.10, Message RAM](#)).
- **Message RAM Interface:** enables connection between the Message RAM and the other blocks in the MCAN module.
- **Registers and Message Object Access:** data consistency is ensured by indirect accesses to the message objects. The interface registers have the same word-length as the Message RAM.

- **Module Interface:** provides connection to the Registers and Message Object Access block and Message RAM Interface block
- **Clocking:** two clocks are provided to the MCAN module: the peripheral synchronous clock (interface clock ICLK) and the peripheral asynchronous clock (functional clock - FCLK).
- **Extension Interface:** this interface is used for DMA requests signaling (see [Section 13.4.1.4.2.2](#)).

13.4.1.4.1 Module Clocking Requirements

Two clocks are provided to the MCAN module:

- the peripheral synchronous clock (ICLK) as the general module clock source
- and the peripheral asynchronous clock (FCLK) provided to the CAN core for generating the CAN bit timing.

Within the MCAN module there is a synchronization mechanism implemented to ensure safe data transfer between the two clock domains. There is synchronization between the signals from the Host clock domain to the CAN clock domain and vice versa and between the reset signal to the Host clock domain and to the CAN clock domain.

Note

ICLK must always be higher or equal to FCLK, in order to achieve a stable functionality of the MCAN module. Here, also the frequency shift of the modulated ICLK has to be considered:

$$f_{0,ICLK} \pm \Delta f_{FM,ICLK} \geq f_{FCLK}$$

For more information on how to configure the relevant clock source registers, see [Section 6.4, Clocking](#) and the device-specific Datasheet.

13.4.1.4.2 Interrupt and DMA Requests

The MCAN module provides interrupt and DMA requests. They are configured via the Host CPU. The Suspend Mode is requesting or forcing (based on MCANSS_CTRL[3] DBG_SUSP_FREE bit) the MCAN module to go into initialization mode (see MCAN_CCCR[0] INIT bit) in which new interrupts and DMA requests will not be issued, that is to prevent the interrupt and DMA requests from propagating to the Host CPU (for more information, see [Section 13.4.1.4.3.8.2, Suspend Mode](#)).

13.4.1.4.2.1 Interrupt Requests

The MCAN module has two interrupt lines. There are 30 internal interrupt sources. Each source can be configured to drive one of the two interrupt lines. The interrupts are 'level high' interrupts.

The MCAN core provides two interrupt requests (for Line 0 and Line 1).

For more information, see the following registers:

- Interrupt Register (MCAN_IR)
- Interrupt Enable (MCAN_IE)
- Interrupt Line Select (MCAN_ILS)
- Interrupt Line Enable (MCAN_ILE)

The MCAN module is capable of issuing ECC interrupts. After clearing the ECC interrupt source, the application software must also write 1 to EOI register (MCANSS_ECC_SEC_EOI_REG/MCANSS_ECC_DED_EOI_REG). For more information, see [ECC Aggregator](#).

The MCAN module supports External Timestamp Counter. When the External Timestamp Counter rolls over it produces an interrupt (see [External Timestamp Counter](#)).

For more information, see the following registers:

- Interrupt Clear Shadow Register (MCANSS_ICS)
- Interrupt Raw Status Register (MCANSS_IRS)
- Interrupt Enable Clear Shadow Register (MCANSS_IECS)
- Interrupt Enable Register (MCANSS_IE)

- Interrupt Enable Status Register (MCANSS_IES)
- End Of Interrupt Register (MCANSS_EOI)
- External Timestamp Prescaler Register (MCANSS_EXT_TS_PRESCALER)
- External Timestamp Unserviced Interrupts Counter Register (MCANSS_EXT_TS_UNSERVICED_INTR_CNTR)

13.4.1.4.2.2 DMA Requests

Functional transmit and Filter DMA requests are generated by the MCAN module based on the signaling in the Extension Interface. The DMA signaling uses a simple DMA request active high pulse.

The active high pulse indicates a pending message is transmitted (see MCAN_TXBRP). This pulse can be used to transfer another message to the Tx Buffer, which would need to be followed by writing 1 to the corresponding MCAN_TXBAR[0] AR bit to mark a new Tx message pending transmission.

The Parity on Tx DMA Events is available using an EDC Controller which can be accessed through the ECC Aggregator.

Standard and Extended message filters can be set to issue a pulse when a filter match occurs. These 'Filter Events' can be used to DMA messages from the Rx FIFO. The events are high level single clock cycle pulses (ICLK).

13.4.1.4.3 Operating Modes

13.4.1.4.3.1 Software Initialization

Setting the MCAN_CCCR[0] INIT bit to 1 starts a software initialization. This is done either by software or by a hardware reset, when an uncorrected bit error was detected in the Message RAM, or by going Bus_Off state. While the MCAN_CCCR[0] INIT bit is set, the message transfer is stopped and the status of the output TX pin is recessive (high). The counters of the Error Management Logic (EML) are unchanged. Setting the MCAN_CCCR[0] INIT bit does not change any configuration register. Resetting the MCAN_CCCR[0] INIT bit finishes the software initialization. After waiting for the occurrence of a sequence of 11 consecutive recessive bits (indication for Bus_Idle state) the message transfer starts.

Access to the MCAN configuration registers is only enabled when both MCAN_CCCR[0] INIT and MCAN_CCCR[1] CCE bits are set (write protection).

The MCAN_CCCR[1] CCE bit can only be set/reset while the MCAN_CCCR[0] INIT = 1. The MCAN_CCCR[1] CCE bit is automatically reset when the MCAN_CCCR[0] INIT bit is reset.

The following registers are reset when the MCAN_CCCR[1] CCE bit is set:

- MCAN_HPMS - High Priority Message Status
- MCAN_RXF0S - Rx FIFO 0 Status
- MCAN_RXF1S - Rx FIFO 1 Status
- MCAN_TXFQS - Tx FIFO/Queue Status
- MCAN_TXBRP - Tx Buffer Request Pending
- MCAN_TXBTO - Tx Buffer Transmission Occurred
- MCAN_TXBCF - Tx Buffer Cancellation Finished
- MCAN_TXEFS - Tx Event FIFO Status

The Timeout Counter value MCAN_TOCV[15-0] TOC field is preset to the value configured by the MCAN_TOCC[31-16] TOP field when the MCAN_CCCR[1] CCE bit is set.

In addition the Tx Handler and Rx Handler are held in idle state while MCAN_CCCR[1] CCE = 1.

The following registers are only writeable while MCAN_CCCR[1] CCE = 0

- MCAN_TXBAR - Tx Buffer Add Request
- MCAN_TXBCR - Tx Buffer Cancellation Request

MCAN_CCCR[7] TEST and MCAN_CCCR[5] MON bits can only be set by the Host CPU while MCAN_CCCR[0] INIT = 1 and MCAN_CCCR[1] CCE = 1. Both bits may be reset at any time. The MCAN_CCCR[6] DAR bit can only be set/reset while MCAN_CCCR[0] INIT = 1

and MCAN_CCCR[1] CCE = 1.

Table 13-256 shows the steps to configure the MCAN module.

Table 13-256. Steps to Configure MCAN Module

Step	Operation	Description	Pseudo Code
1	Initialize MCAN_CCCR	Set MCAN_CCCR[0] INIT bit and check that it has been set	INIT = 1; If INIT ≠ 1, wait until it is
2	Unlock protected registers	Set MCAN_CCCR[1] CCE bit	CCE = 1;
3	Configure CAN mode	Set MCAN_CCCR[8] FDOE bit to CAN FD	FDOE = 1 for CAN FD FDOE = 0 for CAN
4	Configure Bit Rate Switching	Set MCAN_CCCR[9] BRSE bit	BRSE = 1 with bit rate switching BRSE = 0 without bit rate switching
5	Set bit timing	Set MCAN_NBTP register	
6	Lock protected registers	Clear MCAN_CCCR[1] CCE bit	CCE = 0;
7	Return MCAN module to normal operation	Clear MCAN_CCCR[0] INIT bit and check it has been cleared	INIT = 0; If INIT ≠ 0, wait until it is

13.4.1.4.3.2 Normal Operation

Once the MCAN module is initialized and the MCAN_CCCR[0] INIT bit is reset to zero, the MCAN module synchronizes itself to the CAN bus and is ready for communication. After passing the acceptance filtering, received messages including Message Identifier (ID) and Data Length Code (DLC) are stored into a dedicated Rx Buffer or into Rx FIFO 0/Rx FIFO 1.

For messages to be transmitted dedicated Tx Buffers and/or a Tx FIFO or a Tx Queue can be initialized or updated.

Note

Automated transmission on reception of remote frames is not supported.

13.4.1.4.3.3 CAN FD Operation

The CAN FD standard allows extended frames to be sent, up to 64 data bytes in a single frame at a higher bit rate for the data phase of a frame, up to 8 Mbps. The CAN FD standard introduces the ability to switch from one bit rate to another. Extended Data Length (EDL), as shown in Figure 13-225, sets a data length of up to 8 or up to 64 data bytes. Bit Rate Switching (BRS) indicates whether two bit rates (the data phase is transmitted at a different bit rate to the arbitration phase) are enabled.

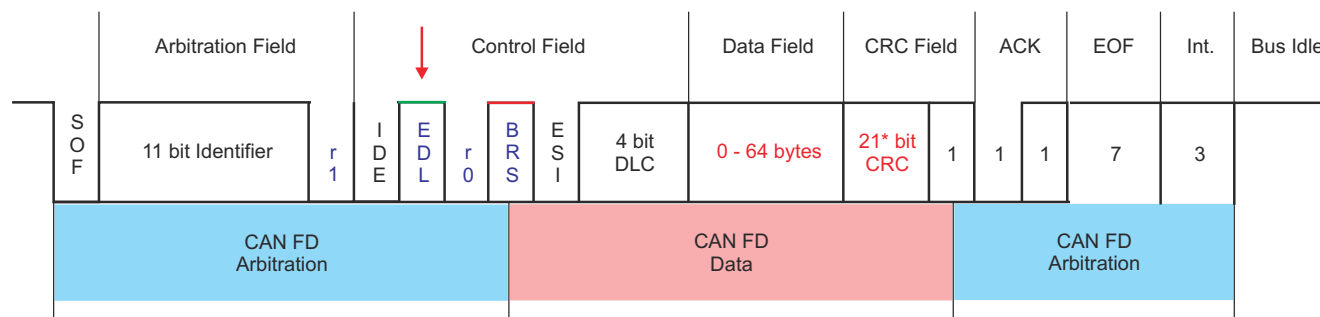

* 17 bit CRC for data fields with up to 16 bytes

mcan-004a

Figure 13-225. CAN FD Frame

Note

Figure 13-225 presents CAN FD frame according to the Non-ISO CAN FD (legacy) protocol. In the new ISO CAN FD protocol the CRC Field includes additional 5 bits (three stuff bit counter (SBC) bits and two parity bits). With these additional bits, a weakness identified in the error detection scheme chosen by the original protocol is removed. By setting MCAN_CCCR[15] NISO bit, the ISO or Non-ISO CAN FD format can be chosen. In CAN network ISO CAN FD and non-ISO CAN FD devices should never mix.

There are two variants of CAN FD frame transmission:

- CAN FD frame transmission without bit rate switching
- CAN FD frame transmission where control field, data field, and CRC field are transmitted with a higher bit rate than the beginning and the end of the frame

In the CAN frames FDF = recessive (logical 1) signifies a CAN FD frame, FDF = dominant (logical 0) signifies a Classic CAN frame. In a CAN FD frame, the two bits following FDF - res and BRS, decide whether the bit rate inside of this CAN FD frame is switched. A CAN FD bit rate switch is signified by res = dominant and BRS = recessive. Note that the coding of res = recessive is reserved for future expansion of the protocol. In case the MCAN module receives a frame with FDF = recessive and res = recessive, it will signal a Protocol Exception Event by setting the MCAN_PSR[14] EXE bit. When Protocol Exception Handling is enabled (MCAN_CCCR[12] PXHD = 0), this causes the operation state to change from Receiver (MCAN_PSR[4-3] ACT = 10) to Integrating (MCAN_PSR[4-3] ACT = 00) at the next sample point. In case Protocol Exception Handling is disabled (MCAN_CCCR[12] PXHD = 1), the MCAN will treat a recessive res bit as an form error and will respond with an error frame.

CAN FD operation is enabled by programming the MCAN_CCCR[8] FDOE bit. In case MCAN_CCCR[8] FDOE = 1, transmission and reception of CAN FD frames is enabled. Transmission and reception of Classic CAN frames is always possible. Whether a CAN FD frame or a Classic CAN frame is transmitted can be configured via the FDF bit in the respective Tx Buffer element.

With MCAN_CCCR[8] FDOE = 0, received frames are interpreted as Classic CAN frames, which leads to the transmission of an error frame when receiving a CAN FD frame. When CAN FD operation is disabled, no CAN FD frames are transmitted even if the FDF bit of a Tx Buffer element is set. The MCAN_CCCR[8] FDOE and MCAN_CCCR[9] BRSE bits can only be changed while the MCAN_CCCR[0] INIT and MCAN_CCCR[1] CCE bits are both set. With MCAN_CCCR[8] FDOE = 0, the setting of bits FDF and BRS is ignored and frames are transmitted in Classic CAN format.

With MCAN_CCCR[8] FDOE = 1 and MCAN_CCCR[9] BRSE = 0, only FDF bit of a Tx Buffer element is evaluated. With MCAN_CCCR[8] FDOE = 1 and MCAN_CCCR[9] BRSE = 1, transmission of CAN FD frames with bit rate switching is enabled. All Tx Buffer elements with bits FDF and BRS set are transmitted in CAN FD format with bit rate switching.

A mode change during CAN operation is only recommended under the following conditions:

- The failure rate in the CAN FD data phase is significant higher than in the CAN FD arbitration phase. In this case disable the CAN FD bit rate switching option for transmissions.
- During system startup all nodes are transmitting Classic CAN messages until it is verified that they are able to communicate in CAN FD format. If this is true, all nodes switch to CAN FD operation.
- Wakeup messages in CAN Partial Networking have to be transmitted in Classic CAN format.
- End-of-line programming in case not all nodes are CAN FD capable. Non CAN FD nodes are held in Silent mode until programming has completed. Then all nodes switch back to Classic CAN communication.

In the CAN FD format, the DLC coding differs from the standard CAN format (see Table 13-257).

Table 13-257. DLC Coding

DLC	0	1	2	3	4	5	6	7	8	9	10	11	12	13	14	15
Number of Data Bytes in Standard CAN	0	1	2	3	4	5	6	7	8	8	8	8	8	8	8	8

Table 13-257. DLC Coding (continued)

DLC	0	1	2	3	4	5	6	7	8	9	10	11	12	13	14	15
Number of Data Bytes in CAN FD	0	1	2	3	4	5	6	7	8	12	16	20	24	32	48	64

For CAN FD frames, the bit timing will be switched inside the frame after the BRS (Bit Rate Switch) bit in case this bit is recessive. In the CAN FD arbitration phase, before the BRS bit, the nominal CAN bit timing (see [Figure 13-226](#)) is used as configured by the Nominal Bit Timing and Prescaler Register MCAN_NBTP. In the following CAN FD data phase, the data phase bit timing is used as configured by the Data Bit Timing and Prescaler Register MCAN_DBTP. The bit timing is switched back from the data phase timing at the CRC delimiter or when an error is detected, whichever occurs first.

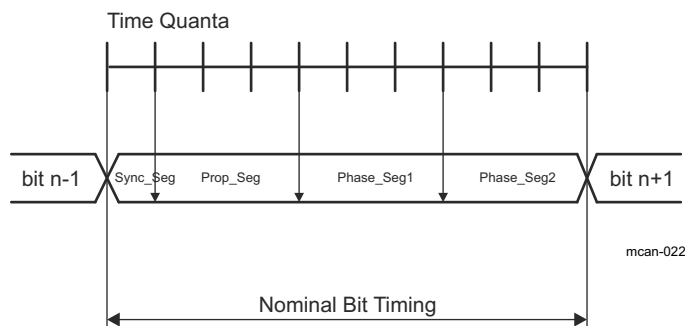

Figure 13-226. CAN Bit Timing

The maximum configurable data phase bit timing depends on the CAN clock frequency (FCLK). Example: with FCLK = 20 MHz and the shortest configurable bit time of 4 t_q (time quanta), the bit rate in the data phase is 5 Mbps.

In both data frame formats, CAN FD and CAN FD with bit rate switching, the value of the ESI (Error Status Indicator) bit depends on transmitter's error state (see MCAN_PSR[11] RESI bit) monitored at the start of the transmission. If the transmitter has error passive flag the ESI bit is transmitted recessive, else it is transmitted dominant.

13.4.1.4.3.4 Transmitter Delay Compensation

13.4.1.4.3.4.1 Description

When only one CAN FD node is transmitting and all others are receivers the length of the bus line has no impact. When transmitting via the TX pin the MCAN module receives the transmitted data from its local CAN transceiver via the RX pin. The received data is delayed. If the transmitter delay is greater than TSEG1 (time segment before sample point), a bit error is detected.

The MCAN module provides a delay compensation mechanism to compensate the transmitter delay. The compensation mechanism enables transmission with higher bit rates during the CAN FD data phase independent of the delay of a specific CAN transceiver. Without transmitter delay compensation the bit rate in the data phase is limited by the transmitter delay.

The mechanism enables configurations where the data bit time is shorter than the transmitter delay (it is described in detail in ISO 11898-1:2015). The transmitter delay compensation is enabled by setting the MCAN_DBTP[23] TDC bit to 1.

The delayed transmit data is compared against the received data at the Secondary Sample Point (SSP) in order to check for bit errors during the data phase of transmitting nodes. If a bit error is detected, the transmitter will react on this bit error at the next following regular sample point. During arbitration phase the delay compensation is always disabled.

The received bit is compared against the transmitted bit at the SSP. The SSP position is defined as the sum of the measured delay from the MCAN's transmit output TX pin through the transceiver to the receive input RX pin plus the transmitter delay compensation offset configured by the MCAN_TDCR[14-8] TDCO field (see [Figure](#)

ADVANCE INFORMATION

13-227). The transmitter delay compensation offset is used to adjust the position of the SSP inside the received bit (example: half of the bit time in the data phase). The position of the SSP is rounded down to the next integer number of mtq.

The actual transmitter delay compensation value can be checked by reading the MCAN_PSR[22-16] TDCV field. This field is cleared when the MCAN_CCCR[0] INIT bit is set and is updated at each transmission of CAN FD frame while the MCAN_DBTP[23] TDC bit is set.

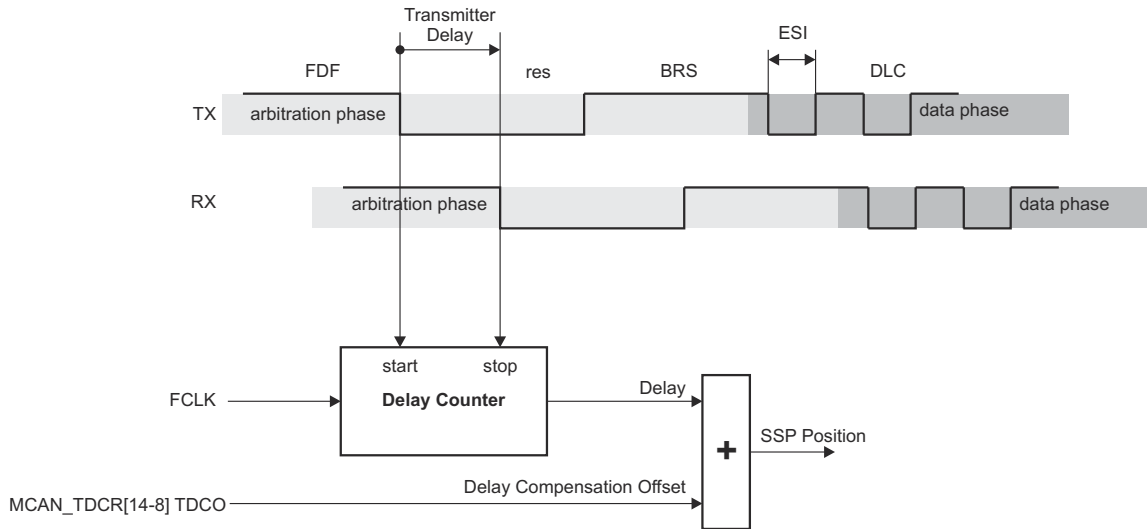

mcan-005

Figure 13-227. Transmitter Delay Measurement

13.4.1.4.3.4.2 Transmitter Delay Compensation Measurement

When transmitter delay compensation is enabled (by programming MCAN_DBTP[23] TDC = 1), the measurement is started within each transmitted CAN FD frame at the falling edge of FDF bit to bit res. The measurement is stopped when this edge is seen at the receive input RX pin of the transmitter. The resolution of this measurement is one mtq (see Figure 13-227). The mtq (minimum time quantum) dimension is equal to the CAN clock period (FCLK).

The use of a transmitter delay compensation filter window can be enabled by programming MCAN_TDCR[6-0] TDCF field. This filter feature defines a minimum value for the SSP position to avoid the case in which a dominant glitch inside the received FDF bit ends the delay compensation measurement before the falling edge of the received res bit, resulting in an early taken SSP position. Dominant edges on the RX pin, that would result in an earlier SSP position are ignored for transmitter delay measurement. The measurement is stopped when the SSP position is at least MCAN_TDCR[6-0] TDCF field and the RX pin is low.

The following boundary conditions have to be considered:

- The sum of the measured delay from the TX pin to the RX pin and the configured transmitter delay compensation offset (MCAN_TDCR[14-8] TDCO field) has to be less than 6 bit times in the data phase.
- The sum of the measured delay from the TX pin to the RX pin and the configured transmitter delay compensation offset (MCAN_TDCR[14-8] TDCO) field has to be less or equal 127 mtq. In case this sum exceeds 127 mtq, the maximum value of 127 mtq is used for transmitter delay compensation.
- The data phase ends at the sample point of the CRC delimiter, that stops checking of receive bits at the SSPs.

13.4.1.4.3.5 Restricted Operation Mode

In Restricted Operation Mode the CAN node is able to receive data and remote frames and acknowledge valid frames, but it does not send data frames, remote frames, active error frames, or overload frames. In case of an error condition or overload condition, it does not send dominant bits, instead it waits for the

occurrence of bus idle condition to resynchronize itself to the CAN communication. The receive and transmit error counters (MCAN_ECR[14-8] REC and MCAN_ECR[7-0] TEC) are frozen, while CAN error logging (MCAN_ECR[23-16] CEL) is active. The Host CPU can set the MCAN module into Restricted Operation Mode by setting MCAN_CCCR[2] ASM bit. The bit can only be set by the Host CPU at any time when both MCAN_CCCR[2] CCE and MCAN_CCCR[0] INIT bits are set to 1.

The Restricted Operation Mode is automatically entered when the Tx Handler does not read data from the Message RAM in time. To leave Restricted Operation Mode, the Host CPU has to reset MCAN_CCCR[2] ASM bit. This mode can be used in applications that adapt themselves to different CAN bit rates. In this case the application tests different bit rates and leaves the Restricted Operation Mode after it has received a valid frame.

Note

Restricted Operation Mode must not be combined with Internal Loopback Mode.

13.4.1.4.3.6 Bus Monitoring Mode

Entering Bus Monitoring Mode is done by setting the MCAN_CCCR[5] MON bit to 1. In this mode (see ISO 11898-1:2015, *Bus Monitoring* section), the MCAN module is able to receive valid data and remote frames, but cannot start a transmission. The MCAN module sends only recessive bits on the CAN bus. If the MCAN module is required to send a dominant bit (ACK bit, overload flag, active error flag), the bit is rerouted internally so that the MCAN module monitors this dominant bit, although the CAN bus may remain in recessive state. In Bus Monitoring Mode the MCAN_TXBRP register is held in reset state. The Bus Monitoring Mode can be used to analyze the traffic on a CAN bus without affecting it by the transmission of dominant bits. Figure 13-228 shows the connection of the TX and RX signals to the MCAN module in Bus Monitoring Mode.

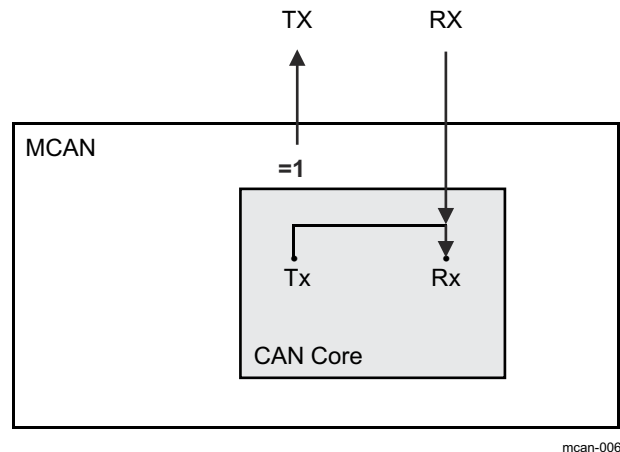

Figure 13-228. Connection of Signals in Bus Monitoring Mode

13.4.1.4.3.7 Disabled Automatic Retransmission (DAR) Mode

According to the CAN Specification (see ISO11898-1:2015, *Recovery Management* section), the MCAN module provides means for automatic retransmission of frames that have lost arbitration or that have been disturbed by errors during transmission. By default automatic retransmission is enabled (see the MCAN_CCCR[6] DAR bit).

13.4.1.4.3.7.1 Frame Transmission in DAR Mode

In DAR mode all transmissions are automatically cancelled after they started on the CAN bus. A Tx Buffer's Tx Request Pending MCAN_TXBRP[xx] TRPx bit is reset after successful transmission, when a transmission has not yet been started at the point of cancellation, has been aborted due to lost arbitration, or when an error occurred during frame transmission.

Successful transmission:

- Corresponding Tx Buffer Transmission Occurred MCAN_TXBTO[xx] TOx bit is set
- Corresponding Tx Buffer Cancellation Finished MCAN_TXBCF[xx] CFx bit is not set

Successful transmission in spite of cancellation:

- Corresponding Tx Buffer Transmission Occurred MCAN_TXBTO[xx] TOx bit is set
- Corresponding Tx Buffer Cancellation Finished MCAN_TXBCF[xx] CFx bit is set

Arbitration lost or frame transmission disturbed:

- Corresponding Tx Buffer Transmission Occurred MCAN_TXBTO[xx] TOx bit is not set
- Corresponding Tx Buffer Cancellation Finished MCAN_TXBCF[xx] CFx bit is set

In case of a successful frame transmission, and if storage of Tx events is enabled, a Tx Event FIFO element is written with Event Type ET = 10 (transmission in spite of cancellation).

13.4.1.4.3.8 Power Down (Sleep Mode)

The entering in Power Down mode is controlled via two sources:

- PSC (via clock stop request signal)
- Software (by writing to the MCAN_CCCR[4] CSR bit)

As long as the clock stop request signal is active, the MCAN_CCCR[4] CSR bit is read as 1.

When all pending transmission requests have completed, the MCAN module waits until bus idle state is detected. Then the MCAN module sets the MCAN_CCCR[0] INIT bit to 1 to prevent any further CAN transfers.

The MCAN module acknowledges that it is ready for power down:

- By asserting clock stop acknowledge signal to the PSC (in case of PSC source).
- By setting the MCAN_CCCR[3] CSA flag bit to 1 (in case of Software source).

In this state, before the clocks are switched off, further register accesses can be made. Now the module clock inputs ICLK and FCLK may be switched off.

To leave power down mode, the application has to turn on the module clocks before resetting the input clock stop request signal respectively the MCAN_CCCR[4] CSR flag bit. The MCAN will acknowledge this by resetting the output clock stop acknowledge signal respectively the MCAN_CCCR[3] CSA flag bit. Afterwards, the application can restart CAN communication by resetting the MCAN_CCCR[0] INIT bit.

Restoring the clocks from clock stop mode, needs to be done according to how the clock stop was initiated:

- If Software asserts the MCAN_CCCR[3] CSA flag bit, once the MCAN module goes idle, the MCAN_CCCR[0] INIT bit is set. To get it started again, Software needs to write 0 to the MCAN_CCCR[0] INIT bit.
- If PSC is issuing a clock stop request, than there are two options for waking up:
 - After removing clock stop request signal, Software would need to write 0 to the MCAN_CCCR[0] INIT bit, or
 - If the MCANSS_CTRL[5] AUTOWAKEUP bit is set, than after removing clock stop request signal, an FSM inside the MCAN module will reset the MCAN_CCCR[0] INIT bit (without Software).

13.4.1.4.3.8.1 External Clock Stop Mode

The MCAN module supports two external clock stop modes:

- Immediate
- Graceful

In a graceful clock stop mode, when the clock stop request is asserted, the MCAN core will respond with clock stop acknowledge when all pending Tx messages have been processed and an Idle line had been detected. The MCAN_CCCR[0] INIT bit will be set, the MCAN core will go and stay Idle.

The automatic wakeup feature is enabled by setting the MCANSS_CTRL[5] AUTOWAKEUP and MCANSS_CTRL[4] WAKEUPREQEN bits to 1 (for more information, see [Section 13.4.1.4.3.8.3, Wakeup request](#)). When external clock stop request is removed and no suspend request is active, a read-modify-write to the MCAN_CCCR[0] INIT bit is performed to clear it.

13.4.1.4.3.8.2 Suspend Mode

The MCAN module supports two suspend modes:

- Immediate
- Graceful

In a graceful suspend mode (see the MCANSS_CTRL[3] DBGSUSP_FREE bit), when the suspend request is asserted, a clock stop request to the MCAN core is performed. The MCAN core will respond with clock stop acknowledge when all pending Tx messages have been processed and an Idle line had been detected. At that point the MCAN_CCCR[0] INIT bit will be set, the MCAN core will go and stay Idle. The suspend state can be verified by reading MCAN_CCCR[0] INIT bit.

The automatic wakeup feature is enabled by setting the MCANSS_CTRL[5] AUTOWAKEUP and MCANSS_CTRL[4] WAKEUPREQEN bits to 1 (for more information, see [Section 13.4.1.4.3.8.3, Wakeup request](#)). When suspend request is removed, if no external clock stop request is active, a read-modify-write to the MCAN_CCCR[0] INIT bit is performed to clear it.

During suspend mode the auto-clear feature is disabled. The following register fields have an auto-clear feature:

- MCAN_ECR[23-16] CEL
- MCAN_PSR[2-0] LEC
- MCAN_PSR[10-8] DLEC
- MCAN_PSR[11] RESI
- MCAN_PSR[12] RBRS
- MCAN_PSR[13] RFDF
- MCAN_PSR[14] PXE

13.4.1.4.3.8.3 Wakeup request

Issuing a clock stop request puts the MCAN module into Power Down mode (Sleep Mode). During transition from IDLE to ACTIVE, if the MCANSS_CTRL[5] AUTOWAKEUP and MCANSS_CTRL[4] WAKEUPREQEN bits are enabled, after the MCAN Core respond to the removal of the clock stop request with removing the clock stop acknowledge, a read-modify-write will be issued to clear the MCAN_CCCR[0] INIT bit and the MCAN core will resume operation. It takes a few FCLK clock cycles for before the write to clear function effects the MCAN_CCCR[0] INIT bit. During clock stop the FCLK clock is turned off and is re-enabled when clock stop request is removed. It takes a few FCLK clock cycles for the FCLK clock to be re-enabled followed by a few more for the synchronization of the MCAN_CCCR[0] INIT bit to take effect. After completion of these steps the MCAN core resumes fully active operation.

If the MCANSS_CTRL[4] WAKEUPREQEN bit is set, the MCAN module provides a wakeup request on the following wakeup event:

- The receive RX pin is dominant (logical 0)

The wakeup request is de-asserted when any of the following conditions occur:

- Clock stop request is removed and clock stop acknowledge is de-asserted
- A reset is applied to the MCAN module

13.4.1.4.3.9 Test Modes

The MCAN_TEST register write access is enabled by setting the test mode enable MCAN_CCCR[7] TEST bit to 1. The MCAN_TEST register allows the configuration of the test modes and test functions.

The CAN transmit TX pin has four output functions. One of those functions can be selected by programming the MCAN_TEST[6-5] TX field. Additionally to its default function (the serial data output) it can drive the CAN Sample Point signal to monitor the MCAN's bit timing and it can drive constant dominant or recessive values.

The actual value of the CAN receive RX pin can be monitored from MCAN_TEST[7] RX bit. Both functions can be used to check the CAN bus physical layer. Due to the synchronization mechanism between CAN clock (FCLK) and Host clock (ICLK) domain, there may be a delay of several Host clock periods between writing to

the MCAN_TEST[6-5] TX field until the new configuration is visible at the output TX pin. This applies also when reading input RX pin via the MCAN_TEST[7] RX bit.

Note

Test modes should be used for self test only. The software control for TX pin interferes with all CAN protocol functions. It is not recommended to use test modes for application.

13.4.1.4.3.9.1 Internal Loopback Mode

The MCAN module can be set into Internal Loopback Mode by programming MCAN_TEST[4] LBCK and MCAN_CCCR[5] MON bits to 1. The Internal Loopback Mode is used for a 'Hot Selftest'. The 'Hot Selftest' allows the MCAN module to be tested without affecting a running CAN system connected to the TX and RX pins. In this mode RX pin is disconnected from the MCAN module and TX pin is held recessive. Figure 13-229 shows the connection of the TX and RX pins to the MCAN module in case of Internal Loopback Mode.

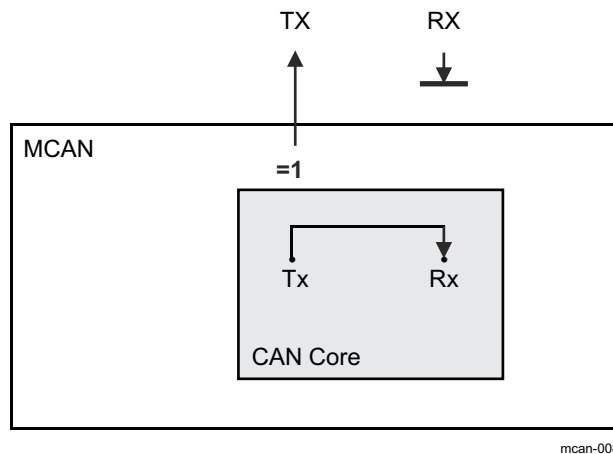

Figure 13-229. Internal Loopback Mode

13.4.1.4.4 Timestamp Generation

The MCAN module has integrated a 16-bit wrap-around counter for timestamp generation. The timestamp counter prescaler MCAN_TSCC[19-16] TCP field can be configured to clock the counter in multiples of CAN bit times (1-16). The counter is readable via the MCAN_TSCV[15-0] TSC field. A write access to the MCAN_TSCV register resets the counter to zero. When the timestamp counter wraps around the interrupt MCAN_IR[16] TSW flag is set. On start of a frame reception/transmission the counter value is captured and stored into the timestamp section of an Rx Buffer/Rx FIFO (RXTS[15-0]) or Tx Event FIFO (TXTS[15-0]) element. For more information, see Section 13.4.1.4.10, Message RAM.

13.4.1.4.4.1 External Timestamp Counter

For CAN FD operation mode the MCAN core requires an External Timestamp Counter. An externally generated 16-bit vector may substitute the integrated 16-bit CAN bit time counter (internal timestamp counter) for receive and transmit timestamp generation. An external 16-bit timestamp counter can be used by programming the MCAN_TSCC[1-0] TSS field.

The External Timestamp Counter uses the interface clock (ICLK) as a reference clock. The MCAN Core accepts a 16-bit timestamp. A 24-bit prescaler provides a programmable resolution for the timestamp (see MCANSS_EXT_TS_PRESCALER[23-0] PRESCALER bit field). The External Timestamp Counter counter can be enabled or disabled through the MCANSS_CTRL[6] EXT_TS_CNTR_EN bit. When disabled the counter is reset back to zero. While enabled the counter keeps incrementing. When the timestamp rolls over the MCAN timestamp interrupt is generated.

When the timestamp rolls over the MCANSS_IRS register is set (see Figure 13-230). The MCANSS_IE register can be affected by writing to the MCANSS_IESS register to set or to the MCANSS_IECS register to clear. The MCANSS_IESS register is a shadow register mapped to the same address as the MCANSS_IE register. The

level interrupt is a reflection of both MCANSS_IRS and MCANSS_IE being set. The MCANSS_IES register reflects the level interrupt. When an rollover event occurs the interrupt counter is incremented. Writing to the MCANSS_ICS register to clear the MCANSS_IRS register will also decrement the interrupt counter. Writing to the MCANSS_EOI register will issue another pulse if the interrupt counter is not zero.

The rollover event can be artificially simulated by software through writing to the Interrupt Set Shadow register (MCANSS_ISS). The MCANSS_ISS register is a shadow register mapped to the same address as the MCANSS_IRS register.

ADVANCE INFORMATION

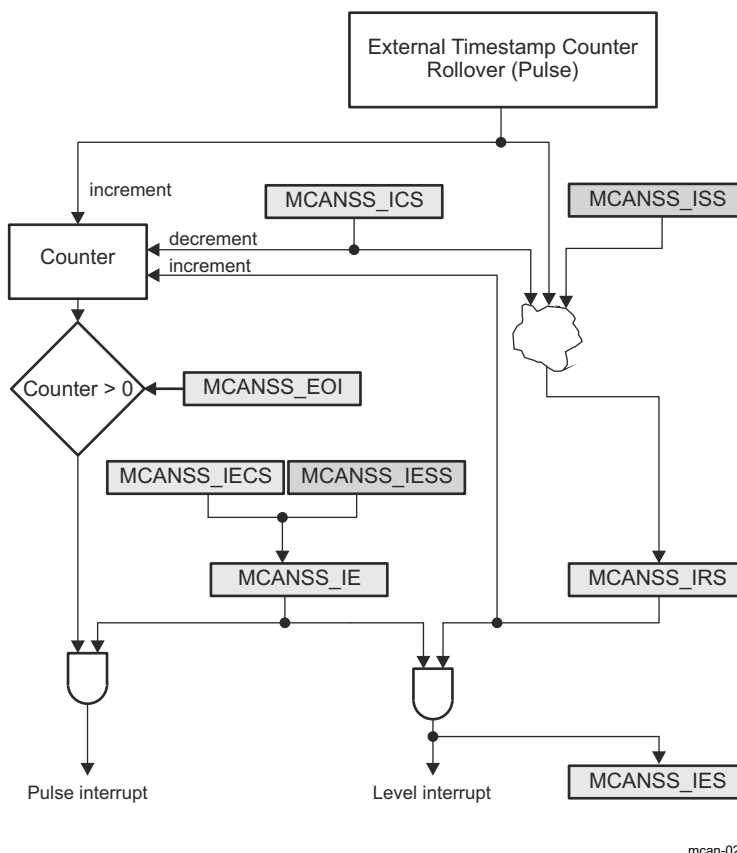

Figure 13-230. External Timestamp Counter Interrupt

13.4.1.4.5 Timeout Counter

The MCAN module has integrated a 16-bit Timeout Counter. It is used to signal timeout conditions for the Rx FIFO 0, Rx FIFO 1, and Tx Event FIFO Message RAM elements. The Timeout Counter is configured via the MCAN_TOCC register. It is enabled via the MCAN_TOCC[0] ETOC bit. The Timeout Counter operates as down-counter and uses the same prescaler programmed by the MCAN_TSCC[19-16] TCP field as the Timestamp Counter. The actual counter value can be monitored from the MCAN_TOCV[15-0] TOC field. The Timeout Counter can be started only when MCAN_CCCR[0] INIT = 0 and stopped when MCAN_CCCR[0] INIT = 1 (example: when the MCAN enters Bus_Off state). The operation mode is selected by the MCAN_TOCC[2-1] TOS field. When Continuous Mode is selected, the counter starts when MCAN_CCCR[0] INIT = 0, a write to the MCAN_TOCV register presets the counter to the value configured by the MCAN_TOCC[31-16] TOP field and continues down-counting.

In case the Timeout Counter is controlled by one of the FIFOs, an empty FIFO presets the counter to the value configured by the MCAN_TOCC[31-16] TOP field. Down-counting is started when the first FIFO element is stored. Writing to the MCAN_TOCV register has no effect. When the counter reaches zero, the interrupt MCAN_IR[18] TOO flag is set.

In Continuous Mode, the counter is immediately restarted at the value configured by the MCAN_TOCC[31-16] TOP field.

13.4.1.4.6 ECC Support

The Message Memory is wrapped in an ECC wrapper providing SECDED parity functionality. The ECC wrapper is controlled by an ECC Aggregator.

13.4.1.4.6.1 ECC Wrapper

The ECC wrapper provides Single Error Correction (SEC) and Double Error Detection (DED) parity to the Message Memory content. It has side band signals for error notification. The ECC Wrapper implements an error injection test mode.

The error correction is done using a lazy write back. When an error is detected, it is noted in a FIFO Queue which waits for an access gap to write the data back and refresh the memory. If a transaction writes new data to the compromised entry before the lazy write back completes, the write back is discarded.

13.4.1.4.7 Rx Handling

The Rx Handler controls the following operations:

- Acceptance filtering
- The transfer of received messages to the Rx Buffers or to one of the two Rx FIFOs (Rx FIFO 0 or Rx FIFO 1)
- Rx FIFO Put and Get Index operations

13.4.1.4.7.1 Acceptance Filtering

The MCAN module is capable to configure two sets of acceptance filters - one set for standard and one set for extended identifiers. These filters can be assigned to an Rx Buffer or to one of the two Rx FIFOs.

The main features of the filter elements are:

- Each filter element can be configured as:
 - Range Filter (from - to)
 - Filter for specific IDs (for one or two dedicated IDs)
 - Classic Bit Mask Filter
- Each filter element can be enabled/disabled individually
- Each filter element can be configured for acceptance or rejection filtering
- Filters are checked sequentially and execution (acceptance filtering procedure) stops at the first matching filter element or when the end of the filter list is reached

Related configuration registers are:

- Global Filter Configuration (MCAN_GFC) register
- Standard ID Filter Configuration (MCAN_SIDFC) register
- Extended ID Filter Configuration (MCAN_XIDFC) register
- Extended ID AND Mask (MCAN_XIDAM) register

Depending on the configuration of the filter element (see SFEC/EFEC in [Section 13.4.1.4.10, Message RAM](#)) if filter matches, one of the following actions is performed:

- Received frame is stored in FIFO 0 or FIFO 1
- Received frame is stored in Rx Buffer
- Received frame is stored in Rx Buffer and generation of pulse at filter event pin is performed. This is high level single ICLK pulse. For more information, see [Section 13.4.1.4.2.1, DMA Requests](#).
- Received frame is rejected
- Set High Priority Message interrupt flag MCAN_IR[8] HPM
- Set High Priority Message interrupt flag MCAN_IR[8] HPM and store received frame in FIFO 0 or FIFO 1

Acceptance filtering starts when complete Message ID is received. Acceptance filtering stops at the first matching enabled filter element or when the end of the filter list is reached. If a filter element matches - the

Rx Handler starts writing the received message data in portions of 32 bit to the matching Rx Buffer or Rx FIFO. If an error condition occurs (for example: CRC error), this message is rejected with the following impact on the affected Rx Buffer or Rx FIFO:

- Rx Buffer:
New Data flag (MCAN_NDAT1/MCAN_NDAT2) of matching Rx Buffer is not set, but Rx Buffer (partly) overwritten with received data (for error type see MCAN_PSR[2-0] LEC respectively MCAN_PSR[10-8] DLEC fields).
- Rx FIFO:
Put index of matching Rx FIFO is not updated, but related Rx FIFO element (partly) overwritten with received data (for error type see MCAN_PSR[2-0] LEC respectively MCAN_PSR[10-8] DLEC fields). If matching Rx FIFO is configured to operate in overwrite mode, the boundary conditions described in [Section 13.4.1.4.7.2.2](#) have to be considered.

13.4.1.4.7.1.1 Range Filter

Each filter element can be configured to operate as Range Filter (Standard Filter Type SFT = 00/Extended Filter Type EFT = 00). The filter matches for all received message frames with IDs in the range from SFID1 to SFID2 (SFID2 ≥ SFID1) respectively in the range from EFID1 to EFID2 (EFID2 ≥ EFID1). For more information see [Section 13.4.1.4.10.5, Standard Message ID Filter Element](#) and [Section 13.4.1.4.10.6, Extended Message ID Filter Element](#).

There are two options for range filtering of extended frames:

- Extended Filter Type EFT = 00: The Extended ID AND Mask (MCAN_XIDAM) is used for Range Filtering. The Message ID of received frames is ANDed with the Extended ID AND Mask (MCAN_XIDAM) before the range filter is applied.
- Extended Filter Type EFT = 11: The Extended ID AND Mask (MCAN_XIDAM) is not used for Range Filtering.

13.4.1.4.7.1.2 Filter for specific IDs

Each filter element can be configured to filter one or two dedicated Message IDs (Standard Filter Type SFT = 01/Extended Filter Type EFT = 01). To filter only one specific Message ID, the filter element has to be configured with SFID1 = SFID2 respectively EFID1 = EFID2. For more information see [Section 13.4.1.4.10.5, Standard Message ID Filter Element](#) and [Section 13.4.1.4.10.6, Extended Message ID Filter Element](#).

13.4.1.4.7.1.3 Classic Bit Mask Filter

Classic bit mask filtering can filter groups of Message IDs (Standard Filter Type SFT = 10/Extended Filter Type EFT = 10). This is done by masking single bits of a received Message ID. In this case SFID1/EFID1 element is used as Message ID filter, while SFID2/EFID2 element is used as filter mask.

A 0 bit at the filter mask (SFID2/EFID2) will mask out the corresponding bit position of the configured Message ID filter (SFID1/EFID1) and the value of the received Message ID at that bit position is not relevant for acceptance filtering. Only those bits of the received Message ID where the corresponding mask bits are 1 are relevant for acceptance filtering.

There are two interesting cases:

- All mask bits are 1: a match occurs only when the received Message ID and the configured Message ID filter are identical.
- All mask bits are 0: all Message IDs match.

13.4.1.4.7.1.4 Standard Message ID Filtering

The standard Message ID (11-bit ID) filtering flow is shown in [Figure 13-231. Section 13.4.1.4.10.5, Standard Message ID Filter Element](#) describes the standard Message ID filter element.

The Remote Transmission Request (RTR) and Extended Identifier (XTD) bits of the received frames are compared against the list of configured filter elements. This is controlled by the following registers:

- Global Filter Configuration (MCAN_GFC) register
- Standard ID Filter Configuration (MCAN_SIDFC) register

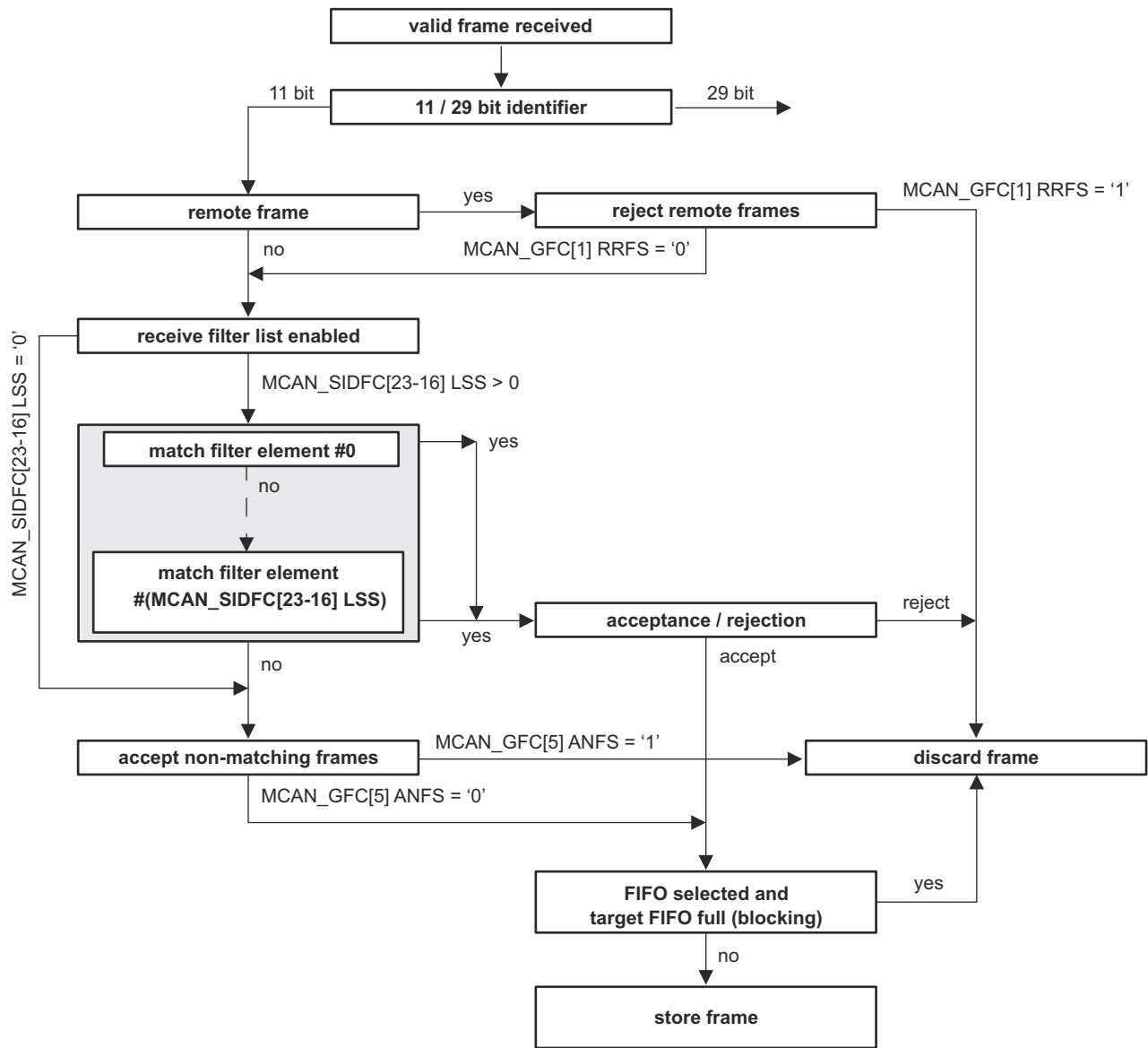

mcan-009

Figure 13-231. Standard Message ID Filter Path

13.4.1.4.7.1.5 Extended Message ID Filtering

The extended Message ID (29-bit ID) filtering flow is shown in [Figure 13-232](#). [Section 13.4.1.4.10.6](#), *Extended Message ID Filter Element* describes the extended Message ID filter element.

The Remote Transmission Request (RTR) and Extended Identifier (XTD) bits of the received frames are compared against the list of configured filter elements. This is controlled by the following registers:

- Global Filter Configuration (MCAN_GFC) register
- Extended ID Filter Configuration (MCAN_XIDFC) register

Note that before the filter list is executed the received identifier is ANDed with the Extended ID AND Mask (MCAN_XIDAM).

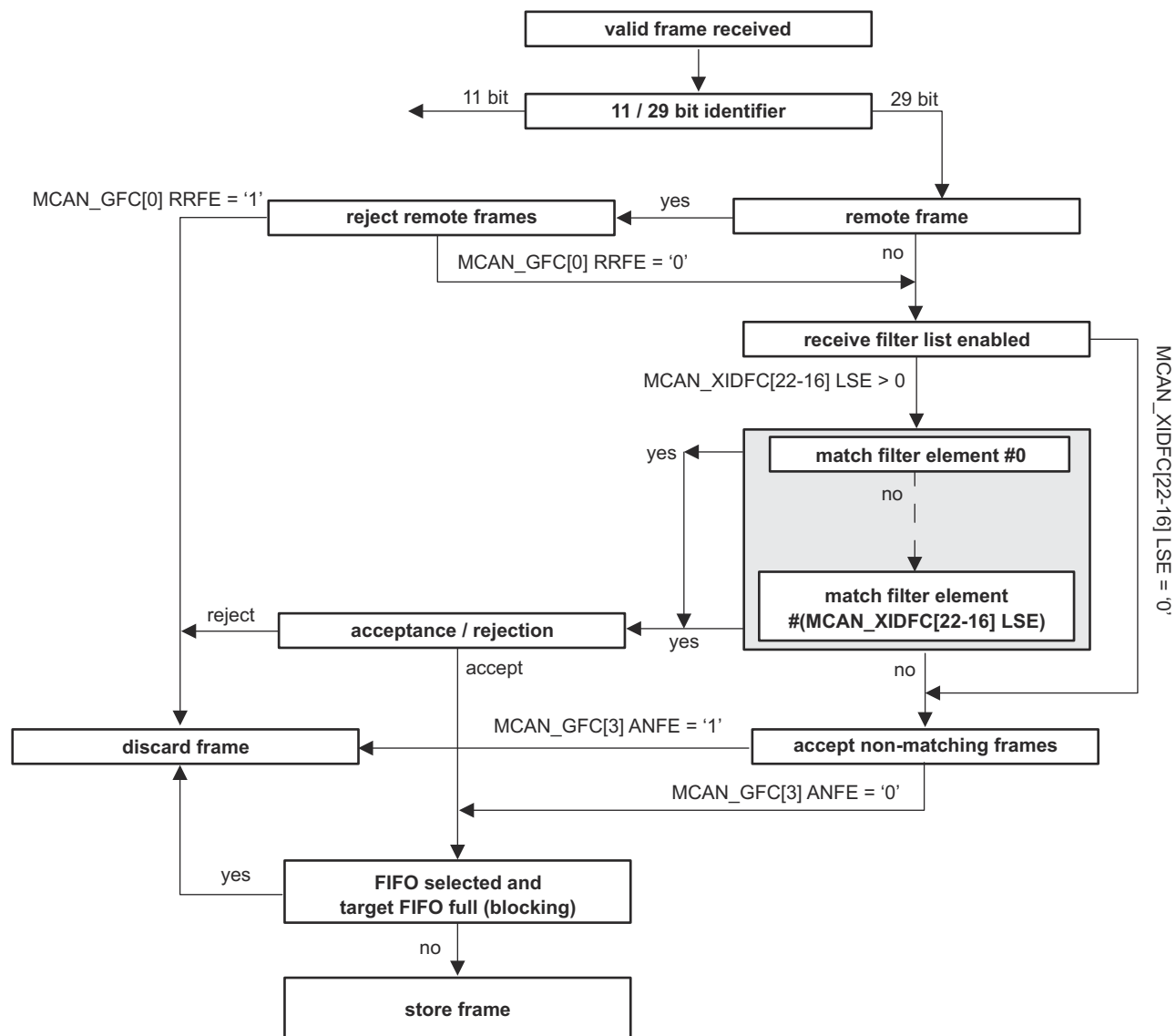

mcan-010

Figure 13-232. Extended Message ID Filter Path

13.4.1.4.7.2 Rx FIFOs

The configuration of the Rx FIFOs (Rx FIFO 0 and Rx FIFO 1) can be done via the MCAN_RXF0C and MCAN_RXF1C registers. Each Rx FIFO can be configured to store up to 64 received messages.

After acceptance filtering the received messages that passed are transferred to the Rx FIFO. The filter mechanisms available for the Rx FIFO 0 and Rx FIFO 1 is described in Section 13.4.1.4.7.1, Acceptance Filtering. Section 13.4.1.4.10.2, Rx Buffer and FIFO Element describes the Rx FIFO element.

The Rx FIFO watermark can be used to prevent an Rx FIFO overflow. If the Rx FIFO fill level reaches the Rx FIFO watermark configured by the MCAN_RXFnC[30-24] FnWM field (where: n = 0 or 1) an interrupt flag MCAN_IR[1] RF0W/MCAN_IR[5] RF1W is set.

When the Rx FIFO Put Index reaches the Rx FIFO Get Index (MCAN_RXFnS[21-16] FnPI = MCAN_RXFnS[13-8] FnGI) an Rx FIFO Full condition is signalled by the MCAN_RXFnS[24] FnF status bit and interrupt flag MCAN_IR[2] RF0F/MCAN_IR[6] RF1F is set. Figure 13-233 shows Rx FIFO Status. The FIFOs fill level is presented in the MCAN_RXFnS[6-0] FnFL field (the number of elements stored in Rx FIFO).

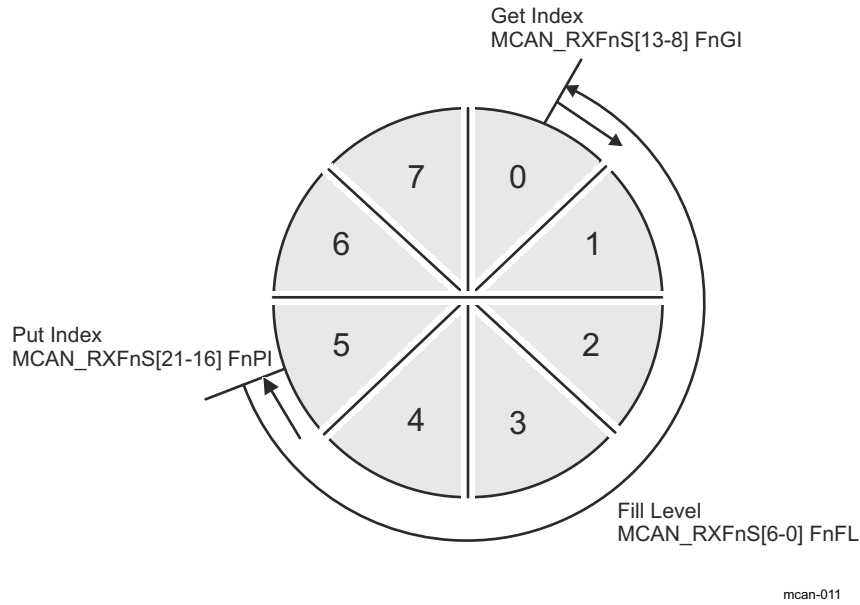

Figure 13-233. Rx FIFO Status

Rx FIFOs start address in the Message RAM (MCAN_RXFnC[15-2] FnSA field) have to be configured when reading from an Rx FIFO (Rx FIFO Get Index - MCAN_RXFnS[13-8] FnGI). Table 13-258 presents Rx Buffer/Rx FIFO Element Size for different Rx Buffer/Rx FIFO Data Field Size which is configured via the MCAN_RXESC register.

Table 13-258. Rx Buffer/Rx FIFO Element Size

MCAN_RXESC[10-8] RBDS MCAN_RXESC[2-0] F0DS/ MCAN_RXESC[6-4] F1DS	Data Field [bytes]	FIFO Element Size [RAM words]
000	8	4
001	12	5
010	16	6
011	20	7
100	24	8
101	32	10
110	48	14
111	64	18

13.4.1.4.7.2.1 Rx FIFO Blocking Mode

The Rx FIFO blocking mode is the default operation mode for the Rx FIFOs. It is configured by the MCAN_RXFnC[31] FnOM = 0.

If an Rx FIFO full condition is reached (MCAN_RXFnS[21-16] FnPI = MCAN_RXFnS[13-8] FnGI), no further messages are written to the corresponding Rx FIFO until at least one message has been read out and the Rx FIFO Get Index has been incremented. An Rx FIFO full condition is signalled by the MCAN_RXFnS[24] FnF = 1 and interrupt flag MCAN_IR[2] RF0F/MCAN_IR[6] RF1F is set.

In case a message is received while the corresponding Rx FIFO is full, this message is rejected and the message lost condition is signalled by MCAN_RXFnS[25] RFnL = 1 and interrupt flag MCAN_IR[3] RFnL/MCAN_IR[25] RFnL is set.

13.4.1.4.7.2.2 Rx FIFO Overwrite Mode

The Rx FIFO overwrite mode is configured by the MCAN_RXFnC[31] FnOM = 1. When an Rx FIFO full condition is reached (MCAN_RXFnS[21-16] FnPI = MCAN_RXFnS[13-8] FnGI) signalled by MCAN_RXFnS[24] FnF = 1,

the next accepted message for the FIFO will overwrite the oldest FIFO message. Put index/Get index are both incremented by one.

In overwrite mode if an Rx FIFO full condition is signalled, reading of the Rx FIFO elements should start at least at get index + 1. The reason for that is, that it might happen, that a received message is written to the Message RAM (Put index) while the Host CPU is reading from the Message RAM (Get index). In this case inconsistent data may be read from the respective Rx FIFO element. The problem is solved by adding an offset to the Get index when reading from the Rx FIFO. The offset depends on how fast the Host CPU accesses the Rx FIFO. Figure 13-234 shows an offset of two with respect to the Get index when reading the Rx FIFO. In this case the two messages stored in element 1 and 2 are lost.

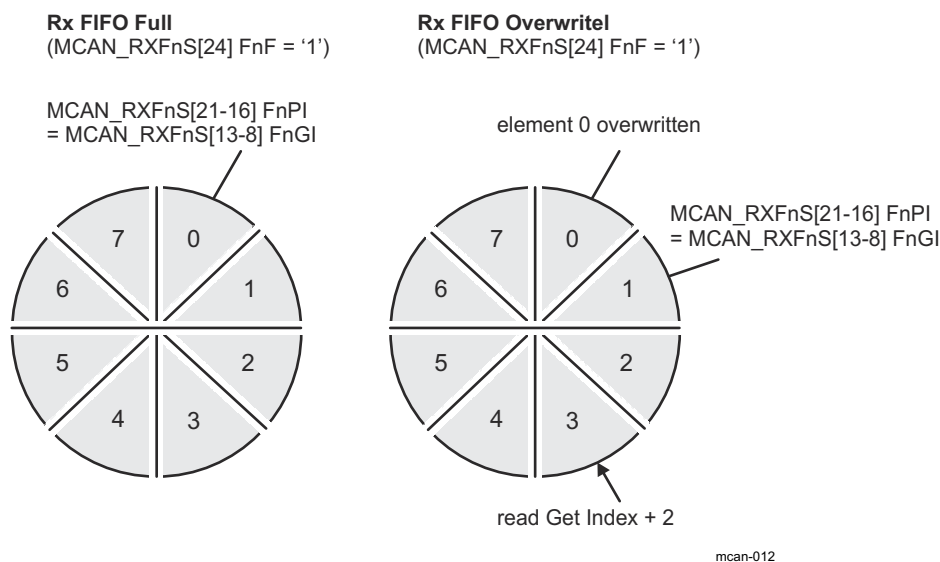

Figure 13-234. Rx FIFO Overflow Handling

After reading from the Rx FIFO, the number of the last element read has to be written to the Rx FIFO Acknowledge Index MCAN_RXFnA[5-0] FnAI. This increments the get index to that element number. In case the Put index has not been incremented to this Rx FIFO element, the Rx FIFO full condition is reset (MCAN_RXFnS[24] FnF = 0).

13.4.1.4.7.3 Dedicated Rx Buffers

The MCAN supports up to 64 dedicated Rx Buffers. The start address of the Rx Buffers section in the Message RAM is configured via MCAN_RXBC[15-2] RBSA field. To store in an Rx Buffer a Standard or Extended Message ID Filter Element with SFEC/EFEC = 111 and SFID2/EFID2[10-9] = 00 has to be configured (see Section 13.4.1.4.10.5, Standard Message ID Filter Element and Section 13.4.1.4.10.6, Extended Message ID Filter Element).

After a received message has been accepted by a filter element, the message is stored into the Rx Buffer in the Message RAM referenced by the filter element (the format is the same as for an Rx FIFO element). In addition the flag MCAN_IR[19] DRX (Message stored in Dedicated Rx Buffer) is set.

Table 13-259 shows Example Filter Configuration for Rx Buffers.

Table 13-259. Example Filter Configuration for Rx Buffers

Filter Element	SFID1[10-0] EFID1[28-0]	SFID2[10-9] EFID2[10-9]	SFID2[5-0] EFID2[5-0]
0	ID message 1	00	00 0000
1	ID message 2	00	00 0001
2	ID message 3	00	00 0010

ADVANCE INFORMATION

After the last word of a matching received message has been written to the Message RAM, the respective New Data flag in register MCAN_NDAT1/MCAN_NDAT2 is set. As long as the New Data flag is set, the respective Rx Buffer is locked against updates from received matching frames. The New Data flags have to be reset by the Host CPU by writing a 1 to the respective bit position.

While an Rx Buffer's New Data flag is set, a Message ID Filter Element referencing this specific Rx Buffer will not match, causing the acceptance filtering to continue. Following Message ID Filter Elements may cause the received message to be stored into another Rx Buffer, or into an Rx FIFO, or the message may be rejected, depending on filter configuration.

13.4.1.4.7.3.1 Rx Buffer Handling

Rx Buffer Handling include the following steps:

- Reset interrupt flag MCAN_IR[19] DRX
- Read New Data registers
- Read messages from Message RAM
- Reset New Data flags of processed messages

13.4.1.4.7.4 Debug on CAN Support

Debug DMA is not supported feature. Debug messages can be traced through the RX FIFO (see [Section 13.4.1.4.7.2](#)).

13.4.1.4.8 Tx Handling

The Tx Handler is used to handle the Tx requests. It controls the transfer of transmit messages from the dedicated Tx Buffers, the Tx FIFO, and the Tx Queue to the CAN Core, the Tx Event FIFO, and the Put and Get Index operations. The MCAN module supports up to 32 Tx Buffers. These Tx Buffers can be configured as dedicated Tx Buffers, Tx FIFO, or Tx Queue and as combination of dedicated Tx Buffers/Tx FIFO or dedicated Tx Buffers/Tx Queue. For each Tx Buffer element Classical CAN or CAN FD transmission mode can be configured. [Section 13.4.1.4.10.3](#) describes the Tx Buffer Element. [Table 13-260](#) shows the possible configurations for message transmission.

Table 13-260. Possible Configurations for Message Transmission

MCAN_CCCR		Tx Buffer Element		Frame Transmission
MCAN_CCCR[9] BRSE	MCAN_CCCR[8] FDOE	FDF	BRS	
ignored	0	ignored	ignored	Classic CAN
0	1	0	ignored	Classic CAN
0	1	1	ignored	CAN FD without bit rate switching
1	1	0	ignored	Classic CAN
1	1	1	0	CAN FD without bit rate switching
1	1	1	1	CAN FD with bit rate switching

When the Tx Buffer Request Pending MCAN_TXBRP register is updated, or when a transmission has been started the Tx Handler starts scanning to check for the highest priority pending Tx request. The Tx Buffer with lowest Message ID has highest priority.

Note

AUTOSAR requires at least three Tx Queue Buffers and support of transmit cancellation.

13.4.1.4.8.1 Transmit Pause

The transmit pause feature is intended for use in CAN networks where the CAN Message IDs are specific and cannot easily be changed. These Message IDs may have a higher priority than other defined Message IDs, while in a specific application their relative priority should be inverse. This allows for a case where one ECU sends a burst of CAN messages that cause another ECU's CAN messages to be delayed (paused).

The transmit pause feature is enabled by the MCAN_CCCR[14] TXP bit. By default this bit is disabled (MCAN_CCCR[14] TXP = 0). Each time after successfully transmitted message, a pause for two CAN bit times occurs before the start of the next transmission. This allows the other CAN nodes in the network to transmit messages even if their Message IDs have lower priority.

13.4.1.4.8.2 Dedicated Tx Buffers

Dedicated Tx Buffers are intended for message transmission under complete control of the Host CPU.

There are two options:

- Each dedicated Tx Buffer is configured with a specific Message ID.
- Two or more dedicated Tx Buffers are configured with the same Message ID. In this case the Tx Buffer with the lowest buffer number is transmitted first.

After the data section has been updated, a transmission is requested by an Add Request. This is done via the MCAN_TXBAR[x]ARn bit (where x = 0 - 31). The requested messages arbitrate internally with messages from an optional Tx FIFO or Tx Queue and externally with messages on the CAN bus, and are sent out according to their Message ID.

Table 13-261 shows Tx Buffer/Tx FIFO/Tx Queue Element Size. A Dedicated Tx Buffer allocates Element Size 32-bit words in the Message RAM. The start address of a dedicated Tx Buffer in the Message RAM is calculated by adding transmit buffer index from 0 to 31 (MCAN_TXFQS[20-16] TFQPI) × Element Size to the Tx Buffer Start Address MCAN_TXBC[15-2] TBSA field.

Table 13-261. Tx Buffer/Tx FIFO/Tx Queue Element Size

MCAN_TXESC[2-0] TBDS	Data Field [bytes]	Element Size [RAM words]
000	8	4
001	12	5
010	16	6
011	20	7
100	24	8
101	32	10
110	48	14
111	64	18

13.4.1.4.8.3 Tx FIFO

Tx FIFO mode is configured by setting bit MCAN_TXBC[30] TFQM = 0. The stored in the Tx FIFO messages are transmitted starting with the message referenced by the Get Index MCAN_TXFQS[12-8] TFGI field. After each transmission the Get Index is incremented until the Tx FIFO is empty. The Tx FIFO Free Level MCAN_TXFQS[5-0] TFFL field indicates the number of the available free Tx FIFO elements. The Tx FIFO allows transmission of messages with the same Message ID from different Tx Buffers in the order these messages have been written to the Tx FIFO.

New transmit messages have to be written to the Tx FIFO starting with the Tx Buffer referenced by the Put Index MCAN_TXFQS[20-16] TFQPI field. After each Add Request (MCAN_TXBAR[x] ARn = 1) the Put Index is incremented to the next free Tx FIFO element. When the Put Index reaches the Get Index (MCAN_TXFQS[20-16] TFQPI = MCAN_TXFQS[12-8] TFGI), Tx FIFO Full condition is signalled by bit MCAN_TXFQS[21] TFQF = 1. In this case no further messages should be written to the Tx FIFO until the next message has been transmitted and the Get Index has been incremented.

The number of requested Tx buffers should not exceed the number of free Tx Buffers as indicated by the Tx FIFO Free Level MCAN_TXFQS[5-0] TFFL field.

In case a transmission request for the Tx Buffer referenced by the Get Index is cancelled, the Get Index is incremented to the next Tx Buffer with pending transmission request and the Tx FIFO Free Level MCAN_TXFQS[5-0] TFFL field is recalculated. In case transmission cancellation is applied to any other Tx Buffer - the Get Index and the FIFO Free Level remain unchanged.

A Tx FIFO element allocates Element Size 32-bit words in the Message RAM (see Table 13-261). The start address of the next available (free) Tx FIFO Buffer is calculated by adding Tx FIFO/Queue Put Index MCAN_TXFQS[20-16] TFQPI (from 0 to 31) × Element Size to the Tx Buffer Start Address MCAN_TXBC[15-2] TBSA field.

13.4.1.4.8.4 Tx Queue

Tx Queue mode is configured by setting bit MCAN_TXBC[30] TFQM = 1. The stored in the Tx Queue messages are transmitted starting with the highest priority message (lowest Message ID). In case two or more Queue Buffers are configured with the same Message ID, the Queue Buffer with the lowest buffer number is transmitted first.

New transmit messages have to be written to the Tx FIFO starting with the Tx Buffer referenced by the Put Index MCAN_TXFQS[20-16] TFQPI field. Each Add Request cyclically increments the Put Index to the next free Tx Buffer. In case of Tx Queue Full condition (MCAN_TXFQS[21] TFQF = 1), the Put Index is not valid and no further message should be written to the Tx Queue until at least one of the requested messages has been sent out or a pending transmission request has been cancelled.

The application may use the MCAN_TXBRP register instead of the Put Index and may place messages to any Tx Buffer without pending transmission request.

A Tx Queue Buffer allocates Element Size 32-bit words in the Message RAM (see Table 13-261). The start address of the next available (free) Tx Queue Buffer is calculated by adding Tx FIFO/Queue Put Index MCAN_TXFQS[20-16] TFQPI (from 0 to 31) × Element Size to the Tx Buffer Start Address MCAN_TXBC[15-2] TBSA field.

13.4.1.4.8.5 Mixed Dedicated Tx Buffers/Tx FIFO

For this combination the Tx Buffers section in the Message RAM is separated in two parts:

- Dedicated Tx Buffers: the number of Dedicated Tx Buffers is configured by the MCAN_TXBC[21-16] NDTB field
- Tx FIFO: the number of Tx Buffers assigned to the Tx FIFO is configured by the MCAN_TXBC[29-24] TFQS field

If the MCAN_TXBC[29-24] TFQS field is empty (zero) - only Dedicated Tx Buffers are used.

Tx prioritization:

- Scan Dedicated Tx Buffers and oldest pending Tx FIFO Buffer (referenced by the MCAN_TXFQS[12-8] TFGI field)
- Buffer with lowest Message ID gets highest priority and is transmitted next

Figure 13-235 shows Mixed Dedicated Tx Buffers/Tx FIFO example.

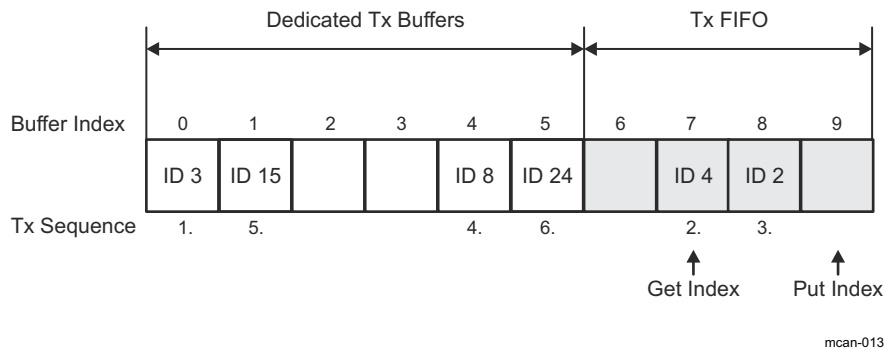

Figure 13-235. Mixed Dedicated Tx Buffers/Tx FIFO (example)

13.4.1.4.8.6 Mixed Dedicated Tx Buffers/Tx Queue

For this combination the Tx Buffers section in the Message RAM is separated in two parts:

- Dedicated Tx Buffers: the number of Dedicated Tx Buffers is configured by the MCAN_TXBC[21-16] NDTB field
- Tx Queue: the number of Tx Buffers assigned to the Tx Queue is configured by the MCAN_TXBC[29-24] TFQS field

If MCAN_TXBC[29-24] TFQS field is empty (zero) - only Dedicated Tx Buffers are used.

Tx prioritization:

- Scan all Tx Buffers with activated transmission request
- Tx Buffer with lowest Message ID gets highest priority and is transmitted next

Figure 13-236 shows Mixed Dedicated Tx Buffers/Tx Queue example.

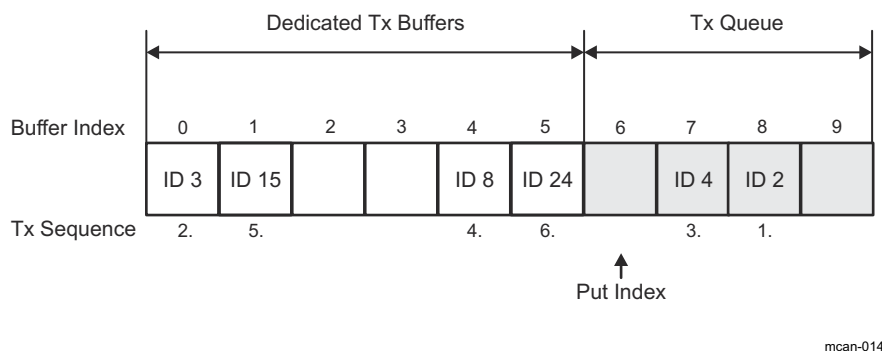

Figure 13-236. Mixed Dedicated Tx Buffers/Tx Queue (example)

13.4.1.4.8.7 Transmit Cancellation

This feature is especially intended for gateway and AUTOSAR based applications. The Host CPU can cancel a requested transmission from a dedicated Tx Buffer or a Tx Queue Buffer by setting bit MCAN_TXBCR[n] CRn = 1 (where n = 0 - 31). The corresponding bit position n is equivalent to the number of the Tx Buffer.

Transmit cancellation is not intended for Tx FIFO operation.

Successful cancellation is signalled by setting the corresponding bit of the MCAN_TXBCF register (MCAN_TXBCF[n] CFn = 1).

If transmission from a Tx Buffer is already ongoing and a transmit cancellation is requested, the corresponding MCAN_TXBRP[n] TRPn bit remains set as long as the transmission is in progress. If the transmission was successful, the corresponding MCAN_TXBTO[n] TOn and MCAN_TXBCF[n] CFn bits are set. If the transmission was not successful, only the corresponding bit MCAN_TXBCF[n] CFn = 1.

Note

If pending transmission is cancelled immediately before this transmission could have been started, a short time window occurs where no transmission is started even if another message is also pending in this node. This may enable another node to transmit a message which may have a lower priority than the second message in this node.

13.4.1.4.8.8 Tx Event Handling

To support Tx Event Handling the Message RAM has implemented a Tx Event FIFO section. Up to 32 Tx Event FIFO elements can be configured. Section 13.4.1.4.10.4 describes the Tx Event FIFO element. After message transmission on the CAN bus, Message ID and Timestamp are stored in a Tx Event FIFO element. To link a Tx Event to a Tx Event FIFO element, the Message Marker from the transmitted Tx Buffer is copied into the Tx Event FIFO element.

A Tx Event FIFO full condition is signalled by the MCAN_IR[14] TEFF bit. In this case no further elements are written to the Tx Event FIFO until at least one element has been read out and the Tx Event FIFO Get Index has

been incremented (MCAN_TXEFS[12-8] EFGI). In case a Tx Event occurs while the Tx Event FIFO is full, this event is rejected and interrupt flag MCAN_IR[15] TEFL bit is set.

The Tx Event FIFO watermark can be configured to avoid a Tx Event FIFO overflow. When the Tx Event FIFO fill level reaches the Tx Event FIFO watermark configured by the MCAN_TXEFC[29-24] EFWM field, interrupt flag MCAN_IR[13] TEFW is set. When reading from the Tx Event FIFO, two times the Tx Event FIFO Get Index MCAN_TXEFS[12-8] EFGI field has to be added to the Tx Event FIFO start address MCAN_TXEFC[15-2] EFSA field.

13.4.1.4.9 FIFO Acknowledge Handling

The Get Indices of the two Rx FIFOs (Rx FIFO 0 or Rx FIFO 1) and the Tx Event FIFO are controlled by writing to the corresponding FIFO Acknowledge Index (see MCAN_RXF0A, MCAN_RXF1A, and MCAN_TXEFA). Writing to the FIFO Acknowledge Index will set the FIFO Get Index to the FIFO Acknowledge Index plus one and thereby updates the FIFO Fill Level.

There are two use cases:

- A single element has been read from the FIFO: the Get Index value is written to the FIFO Acknowledge Index.
- A sequence of elements has been read from the FIFO: the Get Index value (Index of the last element read) is written to the FIFO Acknowledge Index at the end of that read sequence.

The Host CPU has free access to the Message RAM. The special care has to be taken when reading FIFO elements in an arbitrary order (Get Index not considered). This can be useful when reading a High Priority Message from one of the two Rx FIFOs. In this case the FIFO's Acknowledge Index should not be written because this would set the Get Index to a wrong position and also changes the FIFO's Fill Level. In this case some of the older FIFO elements would be lost.

Note

The application has to ensure that a valid value is written to the FIFO Acknowledge Index. The MCAN module does not check for erroneous values.

13.4.1.4.10 Message RAM

The MCAN module has implemented Message RAM. The main purpose of the Message RAM is to store:

- Receive Messages
- Transmit Messages
- Tx Event Elements
- Message ID Filter Elements

13.4.1.4.10.1 Message RAM Configuration

The MCAN module is configured to allocate 4352 words in the Message RAM. The Message RAM has a width of 32 bits.

Table 13-262 presents the Message RAM Address Range for all device MCAN instances.

The Message RAM is capable to include each of the sections listed in Figure 13-237. It is not necessary to configure each of the sections (a section in the Message RAM may be 0) and there is not restriction with respect to the sequence of the sections. For parity checking or ECC a respective number of bits has to be added to each word.

When the MCAN module addresses the Message RAM it addresses 32-bit words. The start addresses are configurable and they are 32-bit word addresses.

The element size can be configured for:

- Rx FIFO 0 via the MCAN_RXESC[2-0] F0DS field
- Rx FIFO 1 via the MCAN_RXESC[6-4] F1DS field
- Rx Buffers via the MCAN_RXESC[10-8] RBDS field
- Tx Buffers via the MCAN_TXESC[2-0] TBDS field

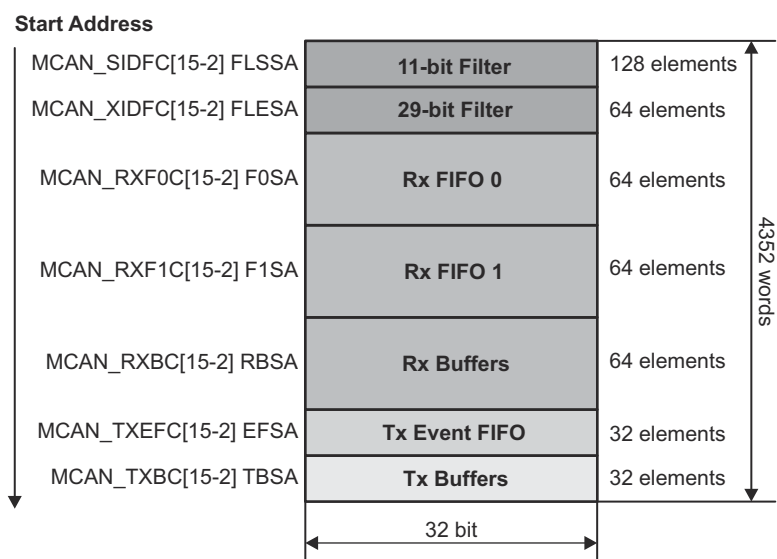

mcan-015

Figure 13-237. Message RAM Configuration

The Host CPU configures the following information in the Message RAM:

- Start addresses of the memory sections
- Number of elements in each section
- The size of the elements in some sections

Note

The MCAN module does not check for errors in the Message RAM configuration. The configuration of the start addresses of the different sections and the number of elements of each section has to be done carefully. This will prevent falsification or loss of data.

13.4.1.4.10.2 Rx Buffer and FIFO Element

Up to 64 Rx Buffers and two Rx FIFOs can be configured in the Message RAM. Each Rx FIFO section can be configured to store up to 64 received messages. The element size can be configured for storage of CAN FD messages with up to 64 bytes data field via the MCAN_RXESC register.

Figure 13-238 shows Rx Buffer/Rx FIFO element structure.

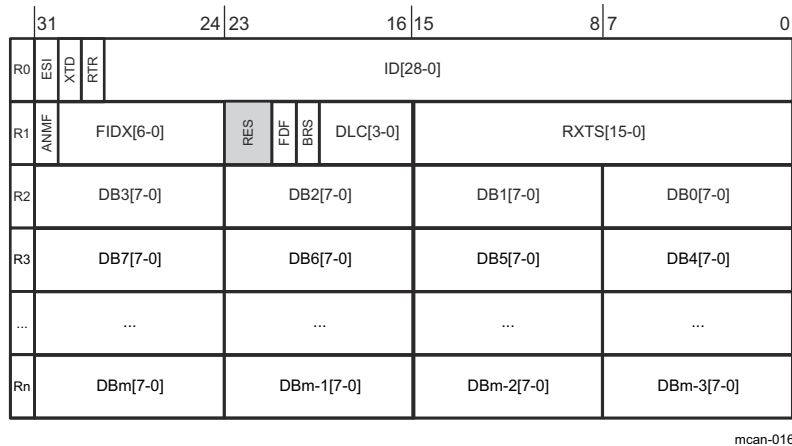

Figure 13-238. Rx Buffer/Rx FIFO Element Structure

Table 13-263 shows Rx Buffer/Rx FIFO element field descriptions.

Table 13-263. Rx Buffer/Rx FIFO Element Field Descriptions

Word	Bits	Field Name	Description
R0	31	ESI	Error State Indicator <ul style="list-style-type: none"> 0h = Transmitting node is error active 1h = Transmitting node is error passive
	30	XTD	Extended Identifier Signals to the Host CPU whether the received frame has a standard or extended identifier. <ul style="list-style-type: none"> 0h = 11-bit standard identifier 1h = 29-bit extended identifier
	29	RTR	Remote Transmission Request Signals to the Host CPU whether the received frame is a data frame or a remote frame. <ul style="list-style-type: none"> 0h = Received frame is a data frame 1h = Received frame is a remote frame <p>Note: There are no remote frames in CAN FD format. In case a CAN FD frame was received (FDF = 1), RTR bit reflects the state of the reserved r1 bit (RES[23]).</p>
	28-0	ID[28-0]	Identifier Standard or extended identifier depending on XTD bit. A standard identifier is stored into ID[28-18].

Table 13-263. Rx Buffer/Rx FIFO Element Field Descriptions (continued)

Word	Bits	Field Name	Description
R1	31	ANMF	Accepted Non-matching Frame Acceptance of non-matching frames may be enabled via the MCAN_GFC[5-4] ANFS and MCAN_GFC[3-2] ANFE fields. <ul style="list-style-type: none"> 0h = Received frame matching filter index FIDX field 1h = Received frame did not match any Rx filter element
	30-24	FIDX[6-0]	Filter Index 0h-7Fh (0-127): Index of matching Rx acceptance filter element (invalid if ANMF = 1). Range is 0 to MCAN_SIDFC[23-16] LSS - 1 respectively MCAN_XIDFC[22-16] LSE - 1.
	23-22	RES	Reserved
	21	FDF	FD Format <ul style="list-style-type: none"> 0h = Standard frame format 1h = CAN FD frame format (new DLC-coding and CRC)
	20	BRS	Bit Rate Switch <ul style="list-style-type: none"> 0h = Frame received without bit rate switching 1h = Frame received with bit rate switching
	19-16	DLC[3-0]	Data Length Code <ul style="list-style-type: none"> 0h-8h (0-8) = CAN + CAN FD: received frame has 0-8 data bytes 9h-Fh (9-15) = CAN: received frame has 8 data bytes 9h-Fh (9-15) = CAN FD: received frame has 12/16/20/24/32/48/64 data bytes
R2	15-0	RXTS[15-0]	Rx Timestamp Timestamp Counter value captured on start of frame reception. Resolution depending on configuration of the Timestamp Counter Prescaler MCAN_TSCC[19-16] TCP.
	31-24	DB3[7-0]	Data Byte 3
	23-16	DB2[7-0]	Data Byte 2
	15-8	DB1[7-0]	Data Byte 1
R3	7-0	DB0[7-0]	Data Byte 0
	31-24	DB7[7-0]	Data Byte 7
	23-16	DB6[7-0]	Data Byte 6
	15-8	DB5[7-0]	Data Byte 5
Rn	7-0	DB4[7-0]	Data Byte 4

	31-24	DBm[7-0]	Data Byte m
	23-16	DBm-1[7-0]	Data Byte m-1
Rn	15-8	DBm-2[7-0]	Data Byte m-2
	7-0	DBm-3[7-0]	Data Byte m-3

Note: Depending on the configuration of the element size (MCAN_RXESC), between two and sixteen 32-bit words (Rn = 3-17) are used for storage of a CAN message's data field.

13.4.1.4.10.3 Tx Buffer Element

The Tx Buffers section can be configured to hold dedicated Tx Buffers as well as a Tx FIFO/Tx Queue. In case that the Tx Buffers section is shared by dedicated Tx buffers and a Tx FIFO/Tx Queue, the dedicated Tx Buffers start at the beginning of the Tx Buffers section followed by the buffers assigned to the Tx FIFO or Tx Queue. The Tx Handler makes difference between dedicated Tx Buffers and Tx FIFO/Tx Queue via the MCAN_TXBC[29-24] TFQS and MCAN_TXBC[21-16] NDTB fields. The element size can be configured for storage of CAN FD messages with up to 64 bytes data field via the MCAN_TXESC register.

Figure 13-239 shows Tx Buffer element structure.

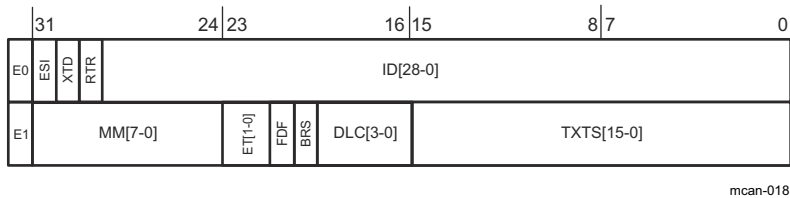

Figure 13-239. Tx Buffer Element Structure

Table 13-264 shows Tx Buffer element field descriptions.

Table 13-264. Tx Buffer Element Field Descriptions

Word	Bits	Field Name	Description
	31	ESI	<p>Error State Indicator</p> <ul style="list-style-type: none"> 0h = ESI bit in CAN FD format depends only on error passive flag 1h = ESI bit in CAN FD format transmitted recessive <p>Note: The ESI bit of the transmit buffer is or'ed with the error passive flag to decide the value of the ESI bit in the transmitted CAN FD frame. As required by the CAN FD protocol specification, an error active node may optionally transmit the ESI bit recessive, but an error passive node will always transmit the ESI bit recessive.</p>
T0	30	XTD	<p>Extended Identifier</p> <ul style="list-style-type: none"> 0h = 11-bit standard identifier 1h = 29-bit extended identifier
	29	RTR	<p>Remote Transmission Request</p> <ul style="list-style-type: none"> 0h = Transmit data frame 1h = Transmit remote frame <p>Note: When RTR = 1, the MCAN module transmits a remote frame according to ISO11898-1:2015, even if the MCAN_CCCR[8] FDOE bit enables the transmission in CAN FD format.</p>
	28-0	ID[28-0]	<p>Identifier</p> <p>Standard or extended identifier depending on XTD bit. A standard identifier has to be written to ID[28-18].</p>

Table 13-264. Tx Buffer Element Field Descriptions (continued)

Word	Bits	Field Name	Description
T1	31-24	MM[7-0]	Message Marker Written by Host CPU during Tx Buffer configuration. Copied into Tx Event FIFO element for identification of Tx message status (see also MM[7-0] field in Table 13-265).
	23	EFC	Event FIFO Control <ul style="list-style-type: none"> 0h = Don't store Tx events 1h = Store Tx events
	22	RES	Reserved
	21	FDF	FD Format <ul style="list-style-type: none"> 0h = Frame transmitted in Classic CAN format 1h = Frame transmitted in CAN FD format
	20	BRS	Bit Rate Switch <ul style="list-style-type: none"> 0h = CAN FD frames transmitted without bit rate switching 1h = CAN FD frames transmitted with bit rate switching <p>Note: ESI, FDF, and BRS bits are only evaluated when CAN FD operation is enabled via the MCAN_CCCR[8] FDOE bit. BRS bit is only evaluated when in addition the MCAN_CCCR[9] BRSE = 1.</p>
	19-16	DLC[3-0]	Data Length Code <ul style="list-style-type: none"> 0h-8h (0-8) = CAN + CAN FD: transmit frame has 0-8 data bytes 9h-Fh (9-15) = CAN: transmit frame has 8 data bytes 9h-Fh (9-15) = CAN FD: transmit frame has 12/16/20/24/32/48/64 data bytes
	15-0	RES	Reserved
T2	31-24	DB3[7-0]	Data Byte 3
	23-16	DB2[7-0]	Data Byte 2
	15-8	DB1[7-0]	Data Byte 1
	7-0	DB0[7-0]	Data Byte 0
T3	31-24	DB7[7-0]	Data Byte 7
	23-16	DB6[7-0]	Data Byte 6
	15-8	DB5[7-0]	Data Byte 5
	7-0	DB4[7-0]	Data Byte 4
...
Tn	31-24	DBm[7-0]	Data Byte m
	23-16	DBm-1[7-0]	Data Byte m-1
	15-8	DBm-2[7-0]	Data Byte m-2
	7-0	DBm-3[7-0]	Data Byte m-3

Note: Depending on the configuration of the element size (MCAN_TXESC), between two and sixteen 32-bit words (Tn = 3-17) are used for storage of a CAN message's data field.

13.4.1.4.10.4 Tx Event FIFO Element

Each element stores information about transmitted messages. By reading the Tx Event FIFO the Host CPU gets this information in the order the messages were transmitted. Status information about the Tx Event FIFO can be obtained from the MCAN_TXEFS register.

Figure 13-240 shows Tx Event FIFO element structure.

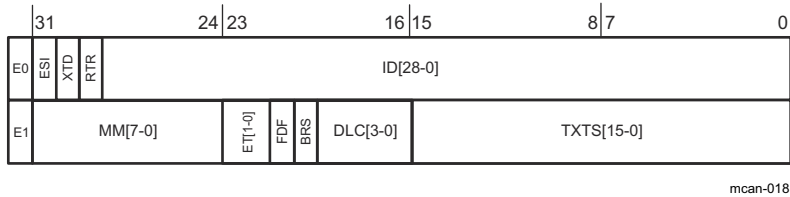

mcan-018

Figure 13-240. Tx Event FIFO Element Structure

Table 13-265 shows Tx Event FIFO element field descriptions.

Table 13-265. Tx Event FIFO Element Field Descriptions

Word	Bits	Field Name	Description
E0	31	ESI	Error State Indicator <ul style="list-style-type: none"> 0h = Transmitting node is error active 1h = Transmitting node is error passive
	30	XTD	Extended Identifier <ul style="list-style-type: none"> 0h = 11-bit standard identifier 1h = 29-bit extended identifier
	29	RTR	Remote Transmission Request <ul style="list-style-type: none"> 0h = Data frame transmitted 1h = Remote frame transmitted
	28-0	ID[28-0]	Identifier Standard or extended identifier depending on XTD bit. A standard identifier has to be written to ID[28-18].

Table 13-265. Tx Event FIFO Element Field Descriptions (continued)

Word	Bits	Field Name	Description
E1	31-24	MM[7-0]	Message Marker Copied from Tx Buffer into Tx Event FIFO element for identification of Tx message status (see also MM[7-0] field in Table 13-264).
	23-22	ET[1-0]	Event Type <ul style="list-style-type: none"> 0h = Reserved 1h = Tx event 2h = Transmission in spite of cancellation (always set for transmissions in DAR mode) 3h = Reserved
	21	FDF	FD Format <ul style="list-style-type: none"> 0h = Standard frame format 1h = CAN FD frame format (new DLC-coding and CRC)
	20	BRS	Bit Rate Switch <ul style="list-style-type: none"> 0h = Frame transmitted without bit rate switching 1h = Frame transmitted with bit rate switching
	19-16	DLC[3-0]	Data Length Code <ul style="list-style-type: none"> 0h-8h (0-8) = CAN + CAN FD: frame with 0-8 data bytes transmitted 9h-Fh (9-15) = CAN: frame with 8 data bytes transmitted 9h-Fh (9-15) = CAN FD: frame with 12/16/20/24/32/48/64 data bytes transmitted
15-0	TXTS[15-0]	Tx Timestamp Timestamp Counter value captured on start of frame transmission. Resolution depending on configuration of the Timestamp Counter Prescaler MCAN_TSSC[19-16] TCP field.	

13.4.1.4.10.5 Standard Message ID Filter Element

Up to 128 filter elements can be configured for 11-bit standard IDs. When accessing a Standard Message ID Filter element, its address is the Filter List Standard Start Address MCAN_SIDFC[15-2] FLSSA field plus the index of the filter element (0-127).

[Figure 13-241](#) shows Standard Message ID Filter element structure.

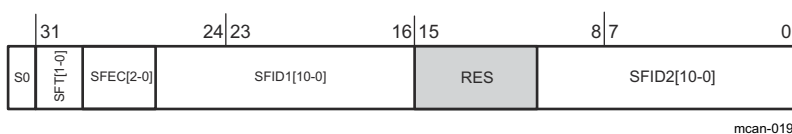
**Figure 13-241. Standard Message ID Filter Element Structure**

[Table 13-266](#) shows Standard Message ID Filter element field descriptions.

Table 13-266. Standard Message ID Filter Element Field Descriptions

Word	Bits	Field Name	Description
	31-30	SFT[1-0]	<p>Standard Filter Type</p> <ul style="list-style-type: none"> 0h = Range filter from SFID1 to SFID2 (SFID2 ≥ SFID1) 1h = Dual ID filter for SFID1 or SFID2 2h = Classic filter: SFID1 = filter; SFID2 = mask 3h = Filter element disabled <p>Note: With SFT = 11 the filter element is disabled and the acceptance filtering continues (same behaviour as with SFEC = 000)</p>
	29-27	SFEC[2-0]	<p>Standard Filter Element Configuration</p> <p>All enabled filter elements are used for acceptance filtering of standard frames. Acceptance filtering stops at the first matching enabled filter element or when the end of the filter list is reached. If SFEC = 100, 101, or 110 a match sets interrupt flag MCAN_IR[8]HPM and, if enabled, an interrupt is generated. In this case the MCAN_HPMS register is updated with the status of the priority match.</p> <ul style="list-style-type: none"> 0h = Disable filter element 1h = Store in Rx FIFO 0 if filter matches 2h = Store in Rx FIFO 1 if filter matches 3h = Reject ID if filter matches 4h = Set priority if filter matches 5h = Set priority and store in FIFO 0 if filter matches 6h = Set priority and store in FIFO 1 if filter matches 7h = Store into Rx Buffer , configuration of SFT[1-0] ignored
S0	26-16	SFID1[10-0]	<p>Standard Filter ID 1</p> <p>When filtering for Rx Buffers this field defines the ID of a standard message to be stored. The received identifiers must match exactly, no masking mechanism is used.</p>
	15-11	RES	Reserved
		SFID2[10-0]	<p>Standard Filter ID 2</p> <p>This bit field has a different meaning depending on the configuration of SFEC:</p> <ul style="list-style-type: none"> 1) SFEC = 001 - 110 Second ID of standard ID filter element 2) SFEC = 111 Filter for Rx Buffers
	10-0	SFID2[10-9]	<p>This field is decides whether the received message is stored into an Rx Buffer or treated as message A, B, or C of the debug message sequence.</p> <ul style="list-style-type: none"> 0h = Store message into an Rx Buffer 1h = Debug Message A 2h = Debug Message B 3h = Debug Message C <p>Note: Debug feature is not supported.</p>
		SFID2[8-6]	<p>This field is used to control the filter event pins at the Extension Interface. A one at the respective bit position enables generation of a pulse at the related filter event pin with the duration of one MCAN_ICKL period in case the filter matches.</p> <p>Note: Only three filter event pins are supported.</p>
		SFID2[5-0]	<p>This field defines the offset to the Rx Buffer Start Address</p>
		MCAN_RXBC[15-2]	<p>RBSA field for storage of a matching message.</p>

13.4.1.4.10.6 Extended Message ID Filter Element

Up to 64 filter elements can be configured for 29-bit extended IDs. When accessing an Extended Message ID Filter element, its address is the Filter List Extended Start Address MCAN_XIDFC[15-2] FLESA field plus two times the index of the filter element (0-63).

Figure 13-242 shows Extended Message ID Filter element structure.

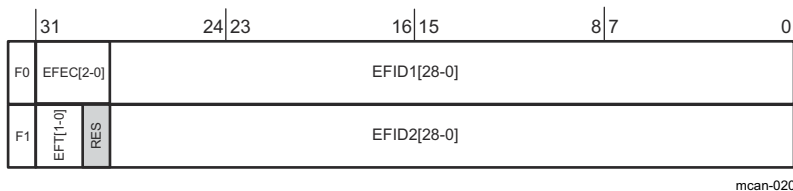

Figure 13-242. Extended Message ID Filter Element Structure

Table 13-267 shows Extended Message ID Filter element field descriptions.

Table 13-267. Extended Message ID Filter Element Field Descriptions

Word	Bits	Field Name	Description
F0	31-29	EFEC[2-0]	Extended Filter Element Configuration All enabled filter elements are used for acceptance filtering of extended frames. Acceptance filtering stops at the first matching enabled filter element or when the end of the filter list is reached. If EFEC = 100, 101, or 110 a match sets interrupt flag MCAN_IR[8]HPM and, if enabled, an interrupt is generated. In this case the MCAN_HPMS register is updated with the status of the priority match.
			<ul style="list-style-type: none"> • 0h = Disable filter element • 1h = Store in Rx FIFO 0 if filter matches • 2h = Store in Rx FIFO 1 if filter matches • 3h = Reject ID if filter matches • 4h = Set priority if filter matches • 5h = Set priority and store in FIFO 0 if filter matches • 6h = Set priority and store in FIFO 1 if filter matches • 7h = Store into Rx Buffer or as debug message, configuration of EFT[1-0] ignored
	28-0	EFID1[28-0]	Extended Filter ID 1 First ID of extended ID filter element. When filtering for Rx Buffers this field defines the ID of an extended message to be stored. The received identifiers must match exactly, only XIDAM masking mechanism (see Section 13.4.1.4.7.1.5, Extended Message ID Filtering) is used.

Table 13-267. Extended Message ID Filter Element Field Descriptions (continued)

Word	Bits	Field Name	Description
F1	31-30	EFT[1-0]	<p>Extended Filter Type</p> <ul style="list-style-type: none"> 0h = Range filter from EFID1 to EFID2 (EFID2 ≥ EFID1) 1h = Dual ID filter for EFID1 or EFID2 2h = Classic filter: EFID1 = filter, EFID2 = mask 3h = Range filter from EFID1 to EFID2 (EFID2 ≥ EFID1), XIDAM mask not applied
	29	RES	Reserved
		EFID2[28-0]	<p>Extended Filter ID 2</p> <p>This bit field has a different meaning depending on the configuration of EFEC:</p> <ul style="list-style-type: none"> 1) EFEC = 001 - 110 Second ID of extended ID filter element 2) EFEC = 111 Filter for Rx Buffers
	28-0	EFID2[10-9]	<p>This field decides whether the received message is stored into an Rx Buffer or treated as message A, B, or C of the debug message sequence.</p> <ul style="list-style-type: none"> 0h = Store message into an Rx Buffer 1h = Debug Message A 2h = Debug Message B 3h = Debug Message C <p>Note: Debug feature is not supported.</p>
		EFID2[8-6]	<p>This field is used to control the filter event pins at the Extension Interface. A one at the respective bit position enables generation of a pulse at the related filter event pin with the duration of one MCAN_IACKL period in case the filter matches.</p> <p>Note: Only three filter event pins are supported.</p>
		EFID2[5-0]	<p>This field defines the offset to the Rx Buffer Start Address MCAN_RXBC[15-2] RBSA field for storage of a matching message.</p>

13.4.2 Local Interconnect Network (LIN)

This chapter describes the local interconnect network (LIN) module. Since this module can also operate like a conventional serial communications interface (SCI) port, it is referred to as the SCI/LIN module in this document. In SCI compatibility mode, it is functionally compatible to the standalone SCI module. However, since the SCI/LIN module uses a different register/bit structure, code written for this module cannot be directly ported to the standalone SCI module and conversely.

This module can be configured to operate in either SCI (UART) or LIN mode.

13.4.2.1 Introduction

The SCI/LIN is compliant to the LIN protocol specified in the *LIN Specification Package*. The SCI/LIN module can be programmed to work either as an SCI or as a LIN. The SCI hardware features are augmented to achieve LIN compatibility.

The SCI module is a universal asynchronous receiver-transmitter (UART) that implements the standard non-return to zero format.

The LIN standard is based on the SCI (UART) serial data link format. The communication concept is single-commander/multiple-responder with a message identification for multicast transmission between any network nodes.

Throughout the chapter, compatibility mode refers to SCI mode functionality of the SCI/LIN module. [Section 13.4.2.3](#) explains about the SCI functionality and [Section 13.4.2.4](#) explains about the LIN functionality. Though the registers are common for LIN and SCI, the register descriptions has notes to identify the register and bit usage in different modes.

13.4.2.1.1 SCI Features

The following are the features of the SCI module:

- Standard universal asynchronous receiver-transmitter (UART) communication
- Supports full- or half-duplex operation
- Standard non-return to zero (NRZ) format
- Double-buffered receive and transmit functions in compatibility mode
- Supports two individually enabled interrupt lines: level 0 and level 1
- Configurable frame format of 3 to 13 bits per character based on the following:
 - Data word length programmable from one to eight bits
 - Additional address bit in address-bit mode
 - Parity programmable for zero or one parity bit, odd or even parity
 - Stop programmable for one or two stop bits
- Asynchronous communication mode
- Two multiprocessor communication formats allow communication between more than two devices
- Sleep mode is available to free CPU resources during multiprocessor communication and then wake up to receive an incoming message
- The 24-bit programmable baud rate supports 2^{24} different baud rates provide high accuracy baud rate selection
- At 100-MHz peripheral clock, 3.125 Mbits/s is the Max Baud Rate achievable
- Five error flags and Seven status flags provide detailed information regarding SCI events
- Two external pins: LINRX and LINTX
- Multi-buffered receive and transmit units

Note

The SCI/LIN module is functionally compatible with the C2000™ SCI modules, but not directly software compatible due to different register control structures.

The SCI/LIN module does not support UART hardware flow control. This feature can be implemented in software using a general-purpose I/O pin.

The SCI/LIN module does not support isosynchronous mode as there is no SCICLK pin.

13.4.2.1.2 LIN Features

The following are the features of the LIN module:

- Compatibility with LIN 1.3 protocols
- Configurable baud rate up to 20 kpbs
- Two external pins: LINRX and LINTX.
- Multi-buffered receive and transmit units
- Identification masks for message filtering
- Automatic commander header generation
 - Programmable synchronization break field
 - Synchronization field
 - Identifier field
- Responder automatic synchronization
 - Synchronization break detection
 - Optional baud rate update
 - Synchronization validation
- Wake up on LINRX dominant level from transceiver
- Automatic wake up support
 - Wakeup signal generation
 - Expiration times on wakeup signals
- Automatic bus idle detection
- Error detection
 - Bit error
 - Bus error
 - No-response error
 - Checksum error
 - Synchronization field error
 - Parity error
- 2 interrupt lines with priority encoding for:
 - Receive
 - Transmit
 - ID, error, and status
- Support for LIN 2.0 checksum
- Enhanced synchronizer finite state machine (FSM) support for frame processing
- Enhanced handling of extended frames
- Enhanced baud rate generator
- Update wakeup/go to sleep

13.4.2.1.3 Block Diagram

The SCI/LIN module contains the core SCI block with added sub-blocks to support LIN protocol.

The three major components of the SCI Module are:

- **Transmitter (TX)** contains two major registers to perform the double-buffering:
 - The transmitter data buffer register (SCITD) contains data loaded by the CPU to be transferred to the shift register for transmission.
 - The transmitter shift register (SCITXSHF) loads data from the data buffer (SCITD) and shifts data onto the LINTX pin, one bit at a time.
- **Baud Clock Generator**
 - A programmable baud generator produces a baud clock scaled from the input clock VCLK
- **Receiver (RX)** contains two major registers to perform the double-buffering:
 - The receiver shift register (SCIRXSHF) shifts data in from the LINRX pin one bit at a time and transfers completed data into the receive data buffer.
 - The receiver data buffer register (SCIRD) contains received data transferred from the receiver shift register

The SCI receiver and transmitter are double-buffered, and each has its own separate enable and interrupt bits. The receiver and transmitter may each be operated independently or simultaneously in full duplex mode.

To ensure data integrity, the SCI checks the data it receives for breaks, parity, overrun, and framing errors. The bit rate (baud) is programmable to over 16 million different rates through a 24-bit baud-select register. [Figure 13-243](#) shows the detailed SCI block diagram.

The SCI/LIN module is based on the standalone SCI with the addition of an error detector (parity calculator, checksum calculator, and bit monitor), a mask filter, a synchronizer, and a multi-buffered receiver and transmitter. The SCI interface, the DMA control subblocks and the baud generator are modified as part of the hardware enhancements for LIN compatibility. [Figure 13-244](#) shows the SCI/LIN block diagram.

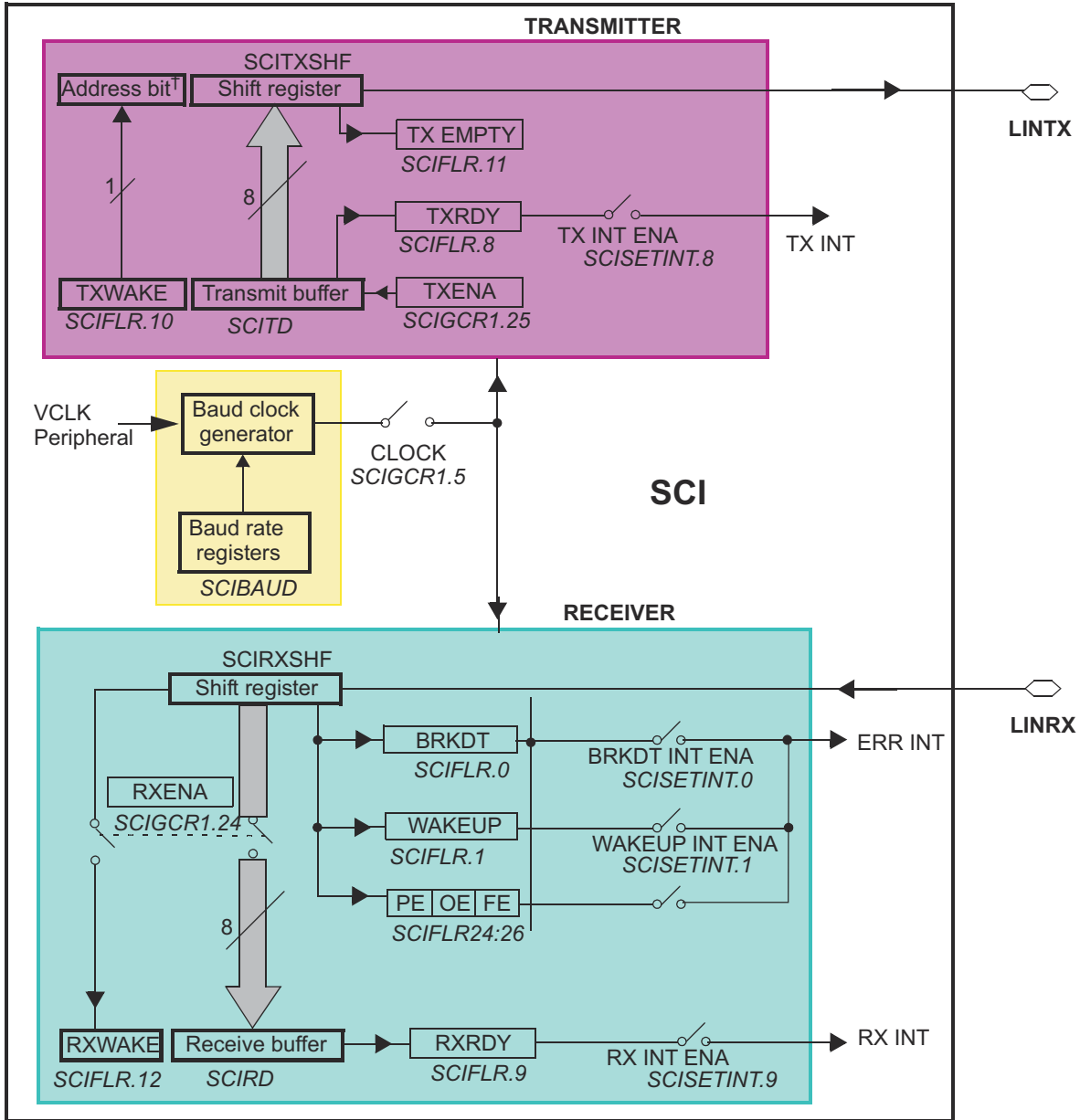

Figure 13-243. SCI Block Diagram

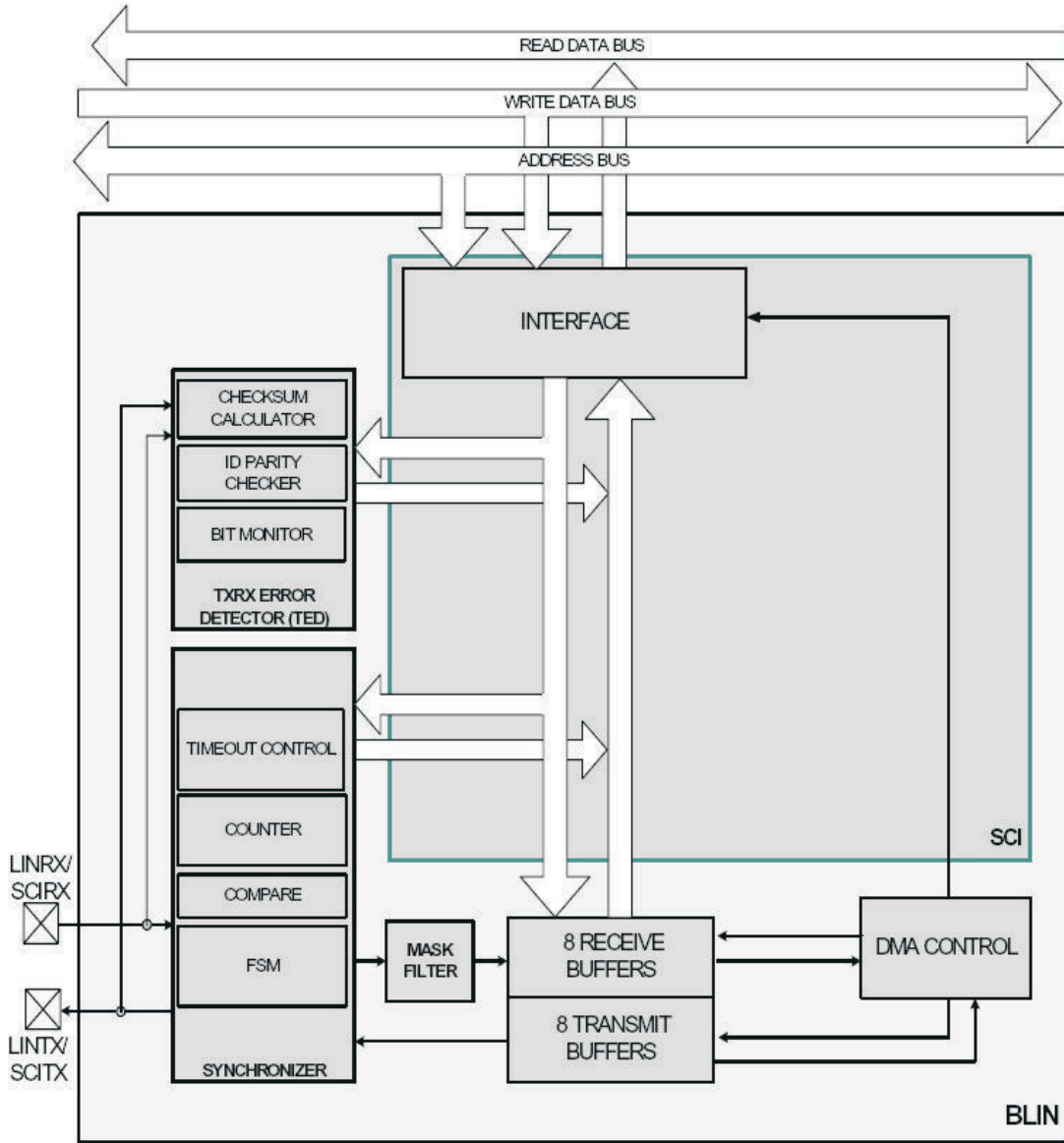

Figure 13-244. SCI/LIN Block Diagram

13.4.2.2 LIN Integration

This section describes modules integration in the device, including information about clocks, resets, and hardware requests.

ADVANCE INFORMATION

There are 5x LIN modules integrated in the device. The diagram below provides a visual representation of the device integration details.

= 0 to 4

Figure 13-245. LIN Integration

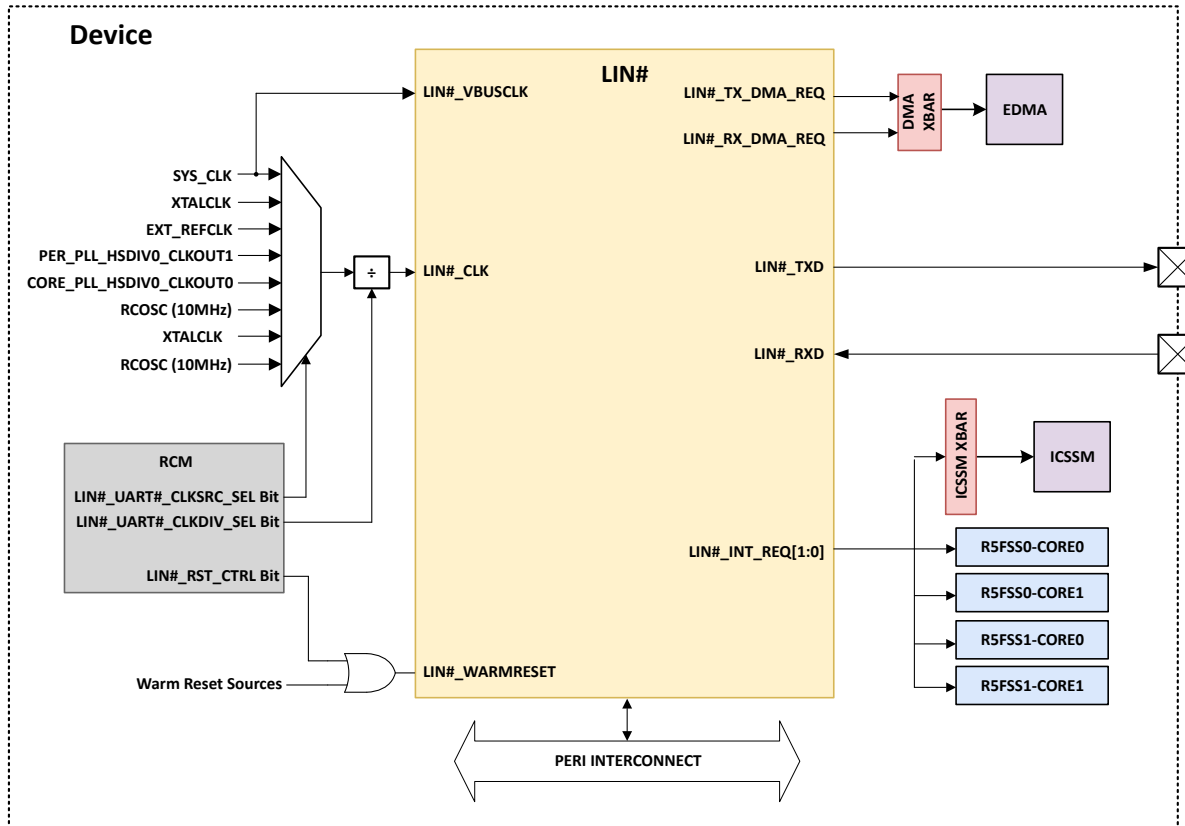

ADVANCE INFORMATION

The tables below summarize the device integration details of LIN# (where # = 5).

Table 13-268. LIN Device Integration

This table describes the LIN device integration details.

LIN Instance	Device Allocation	SoC Interconnect
LIN0	✓	Peripheral VBUSP Interconnect
LIN1	✓	Peripheral VBUSP Interconnect
LIN2	✓	Peripheral VBUSP Interconnect
LIN3	✓	Peripheral VBUSP Interconnect
LIN4	✓	Peripheral VBUSP Interconnect

Table 13-269. LIN Clocks

This table describes the LIN clocking signals.

LIN Instance	LIN Clock Input	Source Clock Signal	Source	Default Freq	Description
LIN0	LIN0_ICLK (VBUSP_CLK)	SYS_CLK	PLL_CORE_CLK: HSDIV0_CLKOUT0	200 MHz	LIN0 Interface Clock (LIN0_CLK should be running for register access)
	LIN0_FCLK (LIN_CLK)	XTALCLK	External XTAL	25 MHz	LIN0 Functional Clock
		EXT_REFCLK	External Reference Clock (EXT_REFCLK)	100 MHz	
		SYS_CLK	PLL_CORE_CLK: HSDIV0_CLKOUT0	200 MHz	
		DPLL_PER_HSDIV0_CLK OUT1	PLL_PER_CLK: HSDIV0_CLKOUT1	192 MHz	
		DPLL_CORE_HSDIV0_CLK KOUT0	PLL_CORE_CLK: HSDIV0_CLKOUT0	400 MHz	
		RCCLK10M	Internal 10MHz RC Oscillator (RCCLK10M)	10 MHz	
		XTALCLK	External XTAL	25 MHz	
		DPLL_PER_HSDIV0_CLK OUT0	PLL_PER_CLK:HSDIV0_C LKOUT0	160 MHz	
LIN1	LIN1_ICLK (VBUSP_CLK)	SYS_CLK	PLL_CORE_CLK: HSDIV0_CLKOUT0	200 MHz	LIN1 Interface Clock (LIN1_CLK should be running for register access)
	LIN1_FCLK (LIN_CLK)	XTALCLK	External XTAL	25 MHz	LIN1 Functional Clock
		EXT_REFCLK	External Reference Clock (EXT_REFCLK)	100 MHz	
		SYS_CLK	PLL_CORE_CLK: HSDIV0_CLKOUT0	200 MHz	
		DPLL_PER_HSDIV0_CLK OUT1	PLL_PER_CLK: HSDIV0_CLKOUT1	192 MHz	
		DPLL_CORE_HSDIV0_CLK KOUT0	PLL_CORE_CLK: HSDIV0_CLKOUT0	400 MHz	
		RCCLK10M	Internal 10MHz RC Oscillator (RCCLK10M)	10 MHz	
		XTALCLK	External XTAL	25 MHz	
		DPLL_PER_HSDIV0_CLK OUT0	PLL_PER_CLK:HSDIV0_C LKOUT0	160 MHz	

Table 13-269. LIN Clocks (continued)

This table describes the LIN clocking signals.

LIN Instance	LIN Clock Input	Source Clock Signal	Source	Default Freq	Description
LIN2	LIN2_ICLK (VBUSP_CLK)	SYS_CLK	PLL_CORE_CLK: HSDIV0_CLKOUT0	200 MHz	LIN2 Interface Clock (LIN2_CLK should be running for register access)
	LIN2_FCLK (LIN_CLK)	XTALCLK	External XTAL	25 MHz	LIN2 Functional Clock
		EXT_REFCLK	External Reference Clock (EXT_REFCLK)	100 MHz	
		SYS_CLK	PLL_CORE_CLK: HSDIV0_CLKOUT0	200 MHz	
		DPLL_PER_HSDIV0_CLK OUT1	PLL_PER_CLK: HSDIV0_CLKOUT1	192 MHz	
		DPLL_CORE_HSDIV0_CL KOUT0	PLL_CORE_CLK: HSDIV0_CLKOUT0	400 MHz	
		RCCLK10M	Internal 10MHz RC Oscillator (RCCLK10M)	10 MHz	
		XTALCLK	External XTAL	25 MHz	
DPLL_PER_HSDIV0_CLK OUT0	PLL_PER_CLK:HSDIV0_C LKOUT0	160 MHz			
LIN3	LIN3_ICLK (VBUSP_CLK)	SYS_CLK	PLL_CORE_CLK: HSDIV0_CLKOUT0	200 MHz	LIN3 Interface Clock (LIN3_CLK should be running for register access)
	LIN3_FCLK (LIN_CLK)	XTALCLK	External XTAL	25 MHz	LIN3 Functional Clock
		EXT_REFCLK	External Reference Clock (EXT_REFCLK)	100 MHz	
		SYS_CLK	PLL_CORE_CLK: HSDIV0_CLKOUT0	200 MHz	
		DPLL_PER_HSDIV0_CLK OUT1	PLL_PER_CLK: HSDIV0_CLKOUT1	192 MHz	
		DPLL_CORE_HSDIV0_CL KOUT0	PLL_CORE_CLK: HSDIV0_CLKOUT0	400 MHz	
		RCCLK10M	Internal 10MHz RC Oscillator (RCCLK10M)	10 MHz	
		XTALCLK	External XTAL	25 MHz	
DPLL_PER_HSDIV0_CLK OUT0	PLL_PER_CLK:HSDIV0_C LKOUT0	160 MHz			

Table 13-269. LIN Clocks (continued)

This table describes the LIN clocking signals.

LIN Instance	LIN Clock Input	Source Clock Signal	Source	Default Freq	Description
LIN4	LIN4_ICLK (VBUSP_CLK)	SYS_CLK	PLL_CORE_CLK: HSDIV0_CLKOUT0	200 MHz	LIN4 Interface Clock (LIN4_CLK should be running for register access)
	LIN4_FCLK (LIN_CLK)	XTALCLK	External XTAL	25 MHz	LIN4 Functional Clock
		EXT_REFCLK	External Reference Clock (EXT_REFCLK)	100 MHz	
		SYS_CLK	PLL_CORE_CLK: HSDIV0_CLKOUT0	200 MHz	
		DPLL_PER_HSDIV0_CLK OUT1	PLL_PER_CLK: HSDIV0_CLKOUT1	192 MHz	
		DPLL_CORE_HSDIV0_CL KOUT0	PLL_CORE_CLK: HSDIV0_CLKOUT0	400 MHz	
		RCCLK10M	Internal 10MHz RC Oscillator (RCCLK10M)	10 MHz	
		XTALCLK	External XTAL	25 MHz	
DPLL_PER_HSDIV0_CLK OUT0	PLL_PER_CLK:HSDIV0_C LKOUT0	160 MHz			

Table 13-270. LIN Resets

This table describes the LIN reset signals.

LIN Instance	LIN Reset Input	Source Reset Signal	Source	Description
LIN0	LIN0_RST (VBUSP_RSTn)	Warm Reset (MOD_G_RST)	RCM + Warm Reset Sources	LIN0 Asynchronous Reset
LIN1	LIN1_RST (VBUSP_RSTn)	Warm Reset (MOD_G_RST)	RCM + Warm Reset Sources	LIN1 Asynchronous Reset
LIN2	LIN2_RST (VBUSP_RSTn)	Warm Reset (MOD_G_RST)	RCM + Warm Reset Sources	LIN2 Asynchronous Reset
LIN3	LIN3_RST (VBUSP_RSTn)	Warm Reset (MOD_G_RST)	RCM + Warm Reset Sources	LIN3 Asynchronous Reset
LIN4	LIN4_RST (VBUSP_RSTn)	Warm Reset (MOD_G_RST)	RCM + Warm Reset Sources	LIN4 Asynchronous Reset

Table 13-271. LIN Interrupt Requests

This table describes the LIN interrupt requests.

LIN Instance	LIN Interrupt Signal	Destination Interrupt Input	Destination	Type	Description
LIN0	LIN0_INT_req_0	LIN0_INT_req_0	ALL R5FSS Cores, ICSSMXBAR	Pulse	LIN0 Event Interrupts
	LIN0_INT_req_1	LIN0_INT_req_1			
LIN1	LIN1_INT_req_0	LIN1_INT_req_0	ALL R5FSS Cores, ICSSMXBAR	Pulse	LIN1 Event Interrupts
	LIN1_INT_req_1	LIN1_INT_req_1			
LIN2	LIN2_INT_req_0	LIN2_INT_req_0	ALL R5FSS Cores, ICSSMXBAR	Pulse	LIN2 Event Interrupts
	LIN2_INT_req_1	LIN2_INT_req_1			

Table 13-271. LIN Interrupt Requests (continued)

This table describes the LIN interrupt requests.

LIN Instance	LIN Interrupt Signal	Destination Interrupt Input	Destination	Type	Description
LIN3	LIN3_INT_req_0	LIN3_INT_req_0	ALL R5FSS Cores, ICSSMXBAR	Pulse	LIN3 Event Interrupts
	LIN3_INT_req_1	LIN3_INT_req_1			
LIN4	LIN4_INT_req_0	LIN4_INT_req_0	ALL R5FSS Cores, ICSSMXBAR	Pulse	LIN4 Event Interrupts
	LIN4_INT_req_1	LIN4_INT_req_1			

Table 13-272. LIN DMA Requests

This table describes the LIN DMA requests.

LIN Instance	LIN DMA Event	Destination DMA Event Input	Destination	Type	Description
LIN0	LIN0_TX_DMA_REQ	LIN0_tx_dma_req	EDMA Crossbar (DMA_XBAR)	Pulse	LIN0 TX DMA Request
	LIN0_RX_DMA_REQ	LIN0_rx_dma_req			LIN0 RX DMA Request
LIN1	LIN1_TX_DMA_REQ	LIN1_tx_dma_req	EDMA Crossbar (DMA_XBAR)	Pulse	LIN1 TX DMA Request
	LIN1_RX_DMA_REQ	LIN1_rx_dma_req			LIN1 RX DMA Request
LIN2	LIN2_TX_DMA_REQ	LIN2_tx_dma_req	EDMA Crossbar (DMA_XBAR)	Pulse	LIN2 TX DMA Request
	LIN2_RX_DMA_REQ	LIN2_rx_dma_req			LIN2 RX DMA Request
LIN3	LIN3_TX_DMA_REQ	LIN3_tx_dma_req	EDMA Crossbar (DMA_XBAR)	Pulse	LIN3 TX DMA Request
	LIN3_RX_DMA_REQ	LIN3_rx_dma_req			LIN3 RX DMA Request
LIN4	LIN4_TX_DMA_REQ	LIN4_tx_dma_req	EDMA Crossbar (DMA_XBAR)	Pulse	LIN4 TX DMA Request
	LIN4_RX_DMA_REQ	LIN4_rx_dma_req			LIN4 RX DMA Request

Note

For more information on the interconnects, see the *System Interconnect* chapter.

For more information on power, reset, and clock management, see the corresponding sections within the *Device Configuration* chapter.

For more information on the device interrupt controllers, see the *Interrupt Controllers* chapter.

13.4.2.3 Serial Communications Interface Module

13.4.2.3.1 SCI Communication Formats

The SCI module can be configured to meet the requirements of many applications. Because communication formats vary depending on the specific application, many attributes of the SCI/LIN are user configurable. The configuration options are:

- SCI Frame format
- SCI Timing modes
- SCI Baud rate
- SCI Multiprocessor modes

13.4.2.3.1.1 SCI Frame Formats

The SCI uses a programmable frame format. All frames consist of the following:

- One start bit
- One to eight data bits
- Zero or one address bit
- Zero or one parity bit
- One or two stop bits

The frame format for both the transmitter and receiver is programmable through the bits in the SCIGCR1 register. Both receive and transmit data is in nonreturn to zero (NRZ) format, which means that the transmit and receive lines are at logic high when idle. Each frame transmission begins with a start bit, in which the transmitter pulls the SCI line low (logic low). Following the start bit, the frame data is sent and received least significant bit first (LSB).

An address bit is present in each frame if the SCI is configured to be in address-bit mode but is not present in any frame if the SCI is configured for idle-line mode. The format of frames with and without the address bit is illustrated in [Figure 13-246](#).

A parity bit is present in every frame when the PARITY ENA bit is set. The value of the parity bit depends on the number of one bits in the frame and whether odd or even parity has been selected via the PARITY ENA bit. Both examples in [Figure 13-246](#) have parity enabled.

All frames include one stop bit, which is always a high level. This high level at the end of each frame is used to indicate the end of a frame to ensure synchronization between communicating devices. Two stop bits are transmitted if the STOP bit in SCIGCR1 register is set. The examples shown in [Figure 13-246](#) use one stop bit per frame.

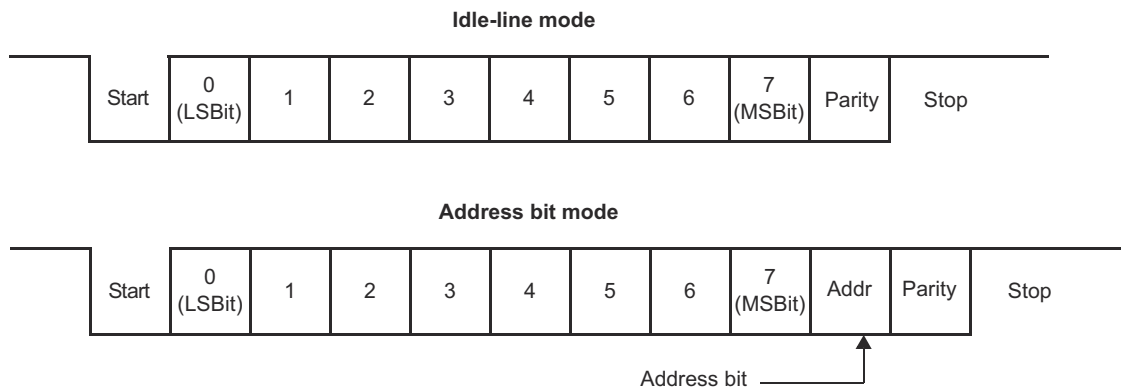

Figure 13-246. Typical SCI Data Frame Formats

13.4.2.3.1.2 SCI Asynchronous Timing Mode

The SCI can be configured to use the asynchronous timing mode using TIMING MODE bit in SCIGCR1 register.

The asynchronous timing mode uses only the receive and transmit data lines to interface with devices using the standard universal asynchronous receiver-transmitter (UART) protocol.

In the asynchronous timing mode, each bit in a frame has a duration of 16 SCI baud clock periods. Each bit therefore consists of 16 samples (one for each clock period). When the SCI is using asynchronous mode, the baud rates of all communicating devices must match as closely as possible. Receive errors result from devices communicating at different baud rates.

With the receiver in the asynchronous timing mode, the SCI detects a valid start bit if the first four samples after a falling edge on the LINRX pin are of logic level 0. As soon as a falling edge is detected on LINRX, the SCI assumes that a frame is being received and synchronizes itself to the bus.

To prevent interpreting noise as Start bit SCI expects LINRX line to be low for at least four contiguous SCI baud clock periods to detect a valid start bit. The bus is considered idle if this condition is not met. When a valid start bit is detected, the SCI determines the value of each bit by sampling the LINRX line value during the seventh, eighth, and ninth SCI baud clock periods. A majority vote of these three samples is used to determine the value stored in the SCI receiver shift register. By sampling in the middle of the bit, the SCI reduces errors caused by propagation delays and rise and fall times and data line noises. [Figure 13-247](#) illustrates how the receiver samples a start bit and a data bit in asynchronous timing mode.

The transmitter transmits each bit for a duration of 16 SCI baud clock periods. During the first clock period for a bit, the transmitter shifts the value of that bit onto the LINTX pin. The transmitter then holds the current bit value on LINTX for 16 SCI baud clock periods.

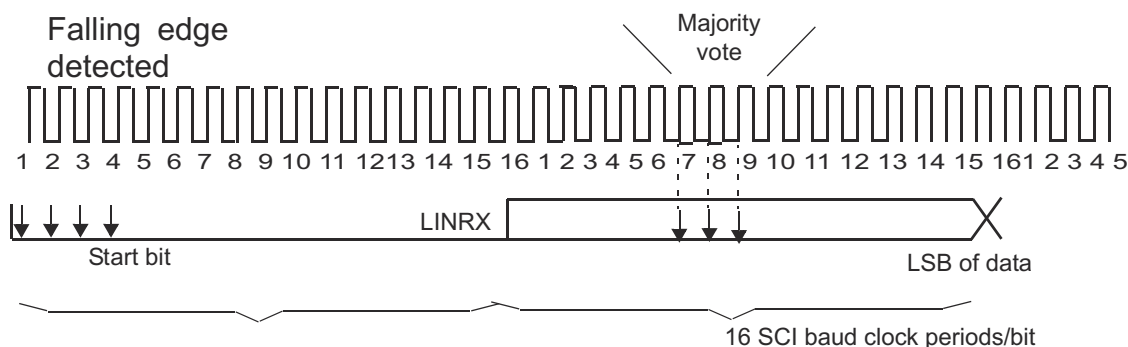

Figure 13-247. Asynchronous Communication Bit Timing

13.4.2.3.1.3 SCI Baud Rate

The SCI/LIN has an internally generated serial clock determined by the peripheral VCLK and the prescalers P and M in this register. The SCI uses the 24-bit integer prescaler P value in the BRS register to select the required baud rates. The additional 4-bit fractional divider M refines the baud rate selection.

In asynchronous timing mode, the SCI generates a baud clock according to the following formula:

$$SCICLK \text{ Frequency} = \frac{VCLK \text{ Frequency}}{P + 1 + \frac{M}{16}}$$

$$\text{Asynchronous baud value} = \frac{SCICLK \text{ Frequency}}{16}$$

For P = 0,

$$\text{Asynchronous baud value} = \frac{VCLK \text{ Frequency}}{32} \quad (25)$$

13.4.2.3.1.4 SCI Multiprocessor Communication Modes

In some applications, the SCI may be connected to more than one serial communication device. In such a multiprocessor configuration, several frames of data may be sent to all connected devices or to an individual device. In the case of data sent to an individual device, the receiving devices must determine when they are being addressed. When a message is not intended for them, the devices can ignore the following data. When only two devices make up the SCI network, addressing is not needed, so multiprocessor communication schemes are not required.

SCI supports two multiprocessor communication modes which can be selected using COMM MODE bit:

- Idle-Line Mode
- Address Bit Mode

When the SCI is not used in a multiprocessor environment, software can consider all frames as data frames. In this case, the only distinction between the idle-line and address-bit modes is the presence of an extra bit (the address bit) in each frame sent with the address-bit protocol.

The SCI allows full-duplex communication where data can be sent and received via the transmit and receive pins simultaneously. However, the protocol used by the SCI assumes that only one device transmits data on the same bus line at any one time. No arbitration is done by the SCI.

13.4.2.3.1.4.1 Idle-Line Multiprocessor Modes

In idle-line multiprocessor mode, a frame that is preceded by an idle period (10 or more idle bits) is an address frame. A frame that is preceded by fewer than 10 idle bits is a data frame. [Figure 13-248](#) illustrates the format of several blocks and frames with idle-line mode.

There are two ways to transmit an address frame using idle-line mode:

Method 1: In software, deliberately leave an idle period between the transmission of the last data frame of the previous block and the address frame of the new block.

Method 2: Configure the SCI to automatically send an idle period between the last data frame of the previous block and the address frame of the new block.

Although Method 1 is only accomplished by a delay loop in software, Method 2 can be implemented by using the transmit buffer and the TXWAKE bit in the following manner:

Step 1: Write a 1 to the TXWAKE bit.

Step 2: Write a dummy data value to the SCITD register. This triggers the SCI to begin the idle period as soon as the transmitter shift register is empty.

Step 3: Wait for the SCI to clear the TXWAKE flag.

Step 4: Write the address value to SCITD.

As indicated by Step 3, software should wait for the SCI to clear the TXWAKE bit. However, the SCI clears the TXWAKE bit at the same time it sets TXRDY (that is, transfers data from SCITD into SCITXSHF). Therefore, if the TX INT ENA bit is set, the transfer of data from SCITD to SCITXSHF causes an interrupt to be generated at the same time that the SCI clears the TXWAKE bit. If this interrupt method is used, software is not required to poll the TXWAKE bit waiting for the SCI to clear it.

When idle-line multiprocessor communications are used, software must ensure that the idle time exceeds 10 bit periods before addresses (using one of the methods mentioned above), and software must also ensure that data frames are written to the transmitter quickly enough to be sent without a delay of 10 bit periods between frames. Failure to comply with these conditions will result in data interpretation errors by other devices receiving the transmission.

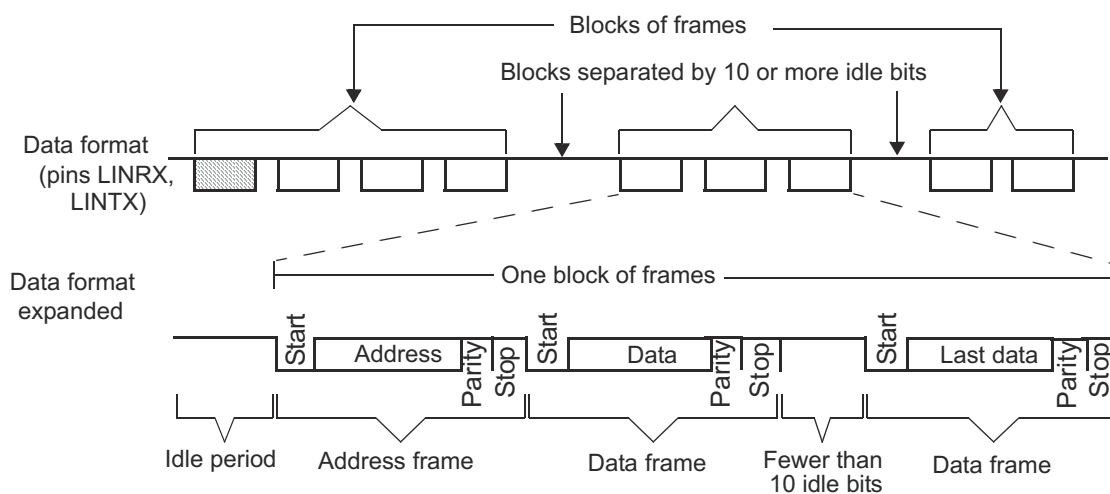

Figure 13-248. Idle-Line Multiprocessor Communication Format

13.4.2.3.1.4.2 Address-Bit Multiprocessor Mode

In the address-bit protocol, each frame has an extra bit immediately following the data field called an address bit. A frame with the address bit set to 1 is an address frame; a frame with the address bit set to 0 is a data frame. The idle period timing is irrelevant in this mode. Figure 13-249 illustrates the format of several blocks and frames with the address-bit mode.

When address-bit mode is used, the value of the TXWAKE bit is the value sent as the address bit. To send an address frame, software must set the TXWAKE bit. This bit is cleared as the contents of the SCITD are shifted from the TXWAKE register so that all frames sent are data except when the TXWAKE bit is written as a 1.

No dummy write to SCITD is required before an address frame is sent in address-bit mode. The first byte written to SCITD after the TXWAKE bit is written to 1 is transmitted with the address bit set when address-bit mode is used.

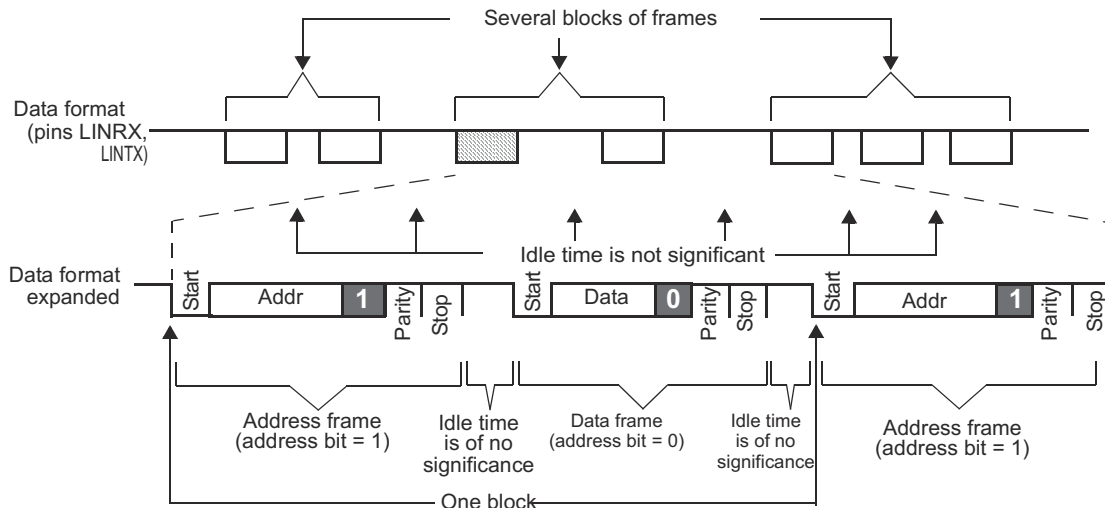

Figure 13-249. Address-Bit Multiprocessor Communication Format

13.4.2.3.1.5 SCI Multi Buffered Mode

To reduce CPU load when Receiving or Transmitting data , the SCI/LIN module has eight separate receive and transmit buffers. Multi-buffered mode is enabled by setting the MBUF MODE bit.

The multi-buffer 3-bit counter counts the data bytes transferred from the SCIRXSHF register to the RDy receive buffers and TDy transmit buffers register to SCITXSHF register. The 3-bit compare register contains the number of data bytes expected to be received or transmitted. the LENGTH value in SCIFORMAT register indicates the expected length and is used to load the 3-bit compare register.

A receive interrupt (RX interrupt; see the SCIINTVECT0 and SCIINTVECT1 registers), and a receive ready RXRDY flag set in SCIFLR register could occur after receiving a response if there are no response receive errors for the frame (such as, there is, frame error, and overrun error).

A transmit interrupt (TX interrupt), and a transmit ready flag (TXRDY flag in SCIFLR register) could occur after transmitting a response.

Figure 13-250 and Figure 13-251 show the receive and transmit multi-buffer functional block diagram, respectively.

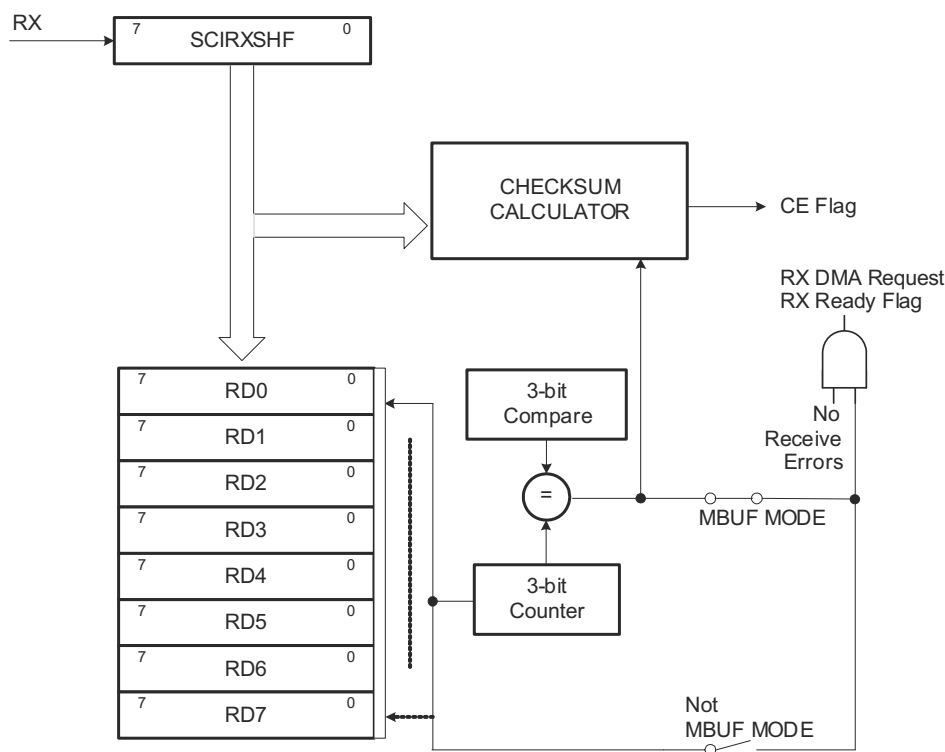

Figure 13-250. Receive Buffers

ADVANCE INFORMATION

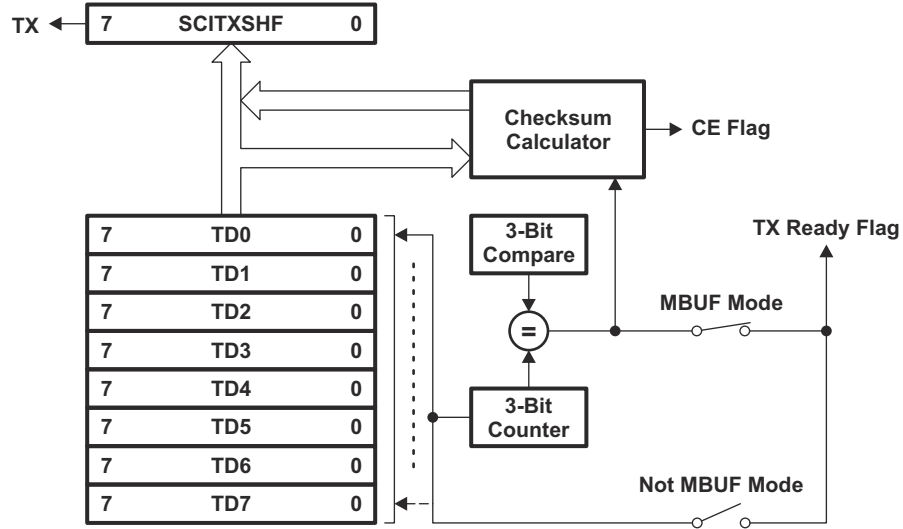

Figure 13-251. Transmit Buffers

13.4.2.3.2 SCI Interrupts

The SCI/LIN module has two interrupt lines, level 0 and level 1, to the vectored interrupt manager (VIM) module (see Figure 13-252). Two offset registers SCIINTVECT0 and SCIINTVECT1 determine which flag triggered the interrupt according to the respective priority encoders. Each interrupt condition has a bit to enable/disable the interrupt in the SCISSETINT and SCICLRINT registers, respectively.

Each interrupt also has a bit that can be set as interrupt level 0(INT0) or as interrupt level 1(INT1). By default, interrupts are in interrupt level 0. SCISSETINTLVL sets a given interrupt to level1. SCICLEARINTLVL resets a given interrupt level to the default level 0.

The interrupt vector registers SCIINTVECT0 and SCIINTVECT1 return the vector of the pending interrupt line INT0 or INT1. If more than one interrupt is pending, the interrupt vector register holds the highest priority interrupt.

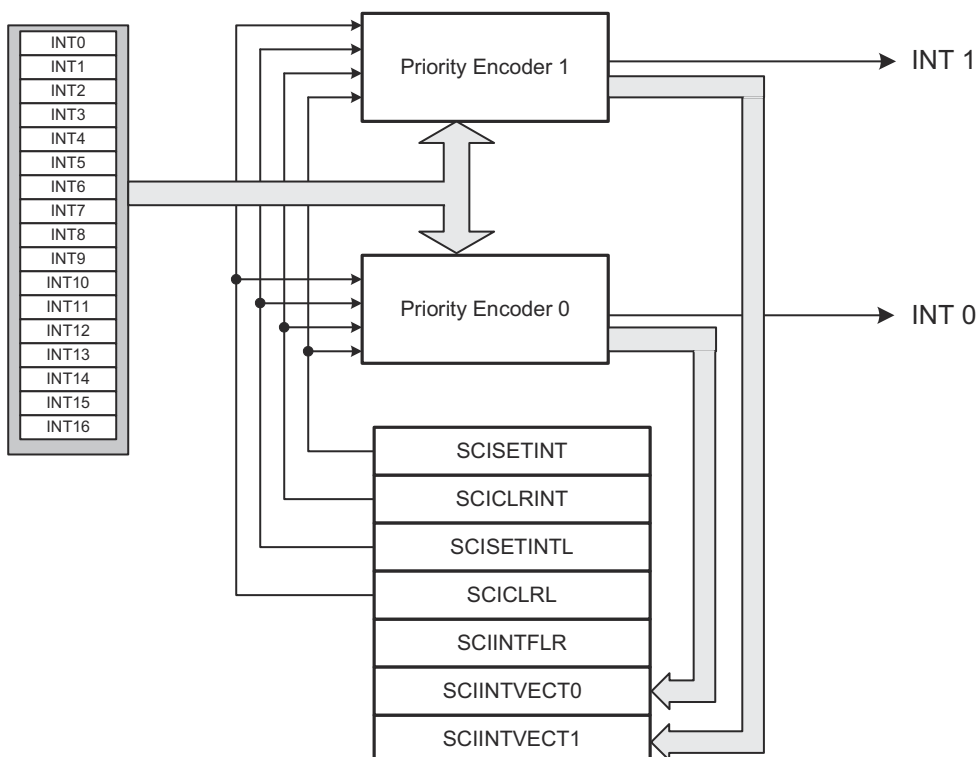

Figure 13-252. General Interrupt Scheme

ADVANCE INFORMATION

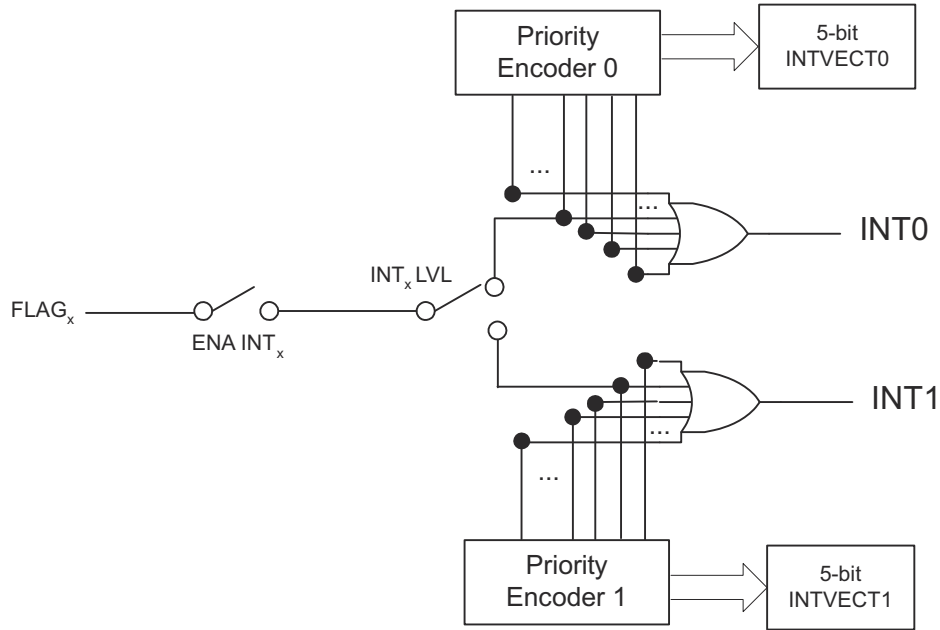

Figure 13-253. Interrupt Generation for Given Flags

13.4.2.3.2.1 Transmit Interrupt

To use transmit interrupt functionality, SET TX INT bit must be enabled. The transmit ready (TXRDY) flag is set when the SCI transfers the contents of SCITD to the shift register, SCITXSHF. The TXRDY flag indicates that SCITD is ready to be loaded with more data. In addition, the SCI sets the TX EMPTY bit if both the SCITD and SCITXSHF registers are empty. If the SET TX INT bit is set, then a transmit interrupt is generated when the TXRDY flag goes high. Transmit Interrupt is not generated immediately after setting the SET TX INT. Transmit Interrupt is generated only after the first transfer from SCITD to SCITXSHF, that is first data has to be written to SCITD before any interrupt gets generated. To transmit further data, data can be written to SCITD in the transmit Interrupt service routine.

Writing data to the SCITD register clears the TXRDY bit. When this data has been moved to the SCITXSHF register, the TXRDY bit is set again. The interrupt request can be suspended by setting the CLR TX INT bit; however, when the SET TX INT bit is again set to 1, the TXRDY interrupt is asserted again. The transmit interrupt request can be eliminated until the next series of values is written to SCITD, by disabling the transmitter via the TXENA bit, by a software reset SWnRST, or by a device hardware reset.

13.4.2.3.2.2 Receive Interrupt

The receive ready (RXRDY) flag is set when the SCI transfers newly received data from SCIRXSHF to SCIRD. The RXRDY flag therefore indicates that the SCI has new data to be read. Receive interrupts are enabled by the SET RX INT bit. If the SET RX INT is set when the SCI sets the RXRDY flag, then a receive interrupt is generated. The received data can be read in the Interrupt Service routine.

13.4.2.3.2.3 WakeUp Interrupt

SCI sets the WAKEUP flag if bus activity on the RX line either prevents power-down mode from being entered, or RX line activity causes an exit from power-down mode. If enabled (SET WAKEUP INT), wakeup interrupt is triggered once WAKEUP flag is set.

13.4.2.3.2.4 Error Interrupts

The following error detections are supported with an interrupt by the SCI module:

- Parity errors (PE)
- Frame errors (FE)
- Break Detect errors (BRKDT)
- Overrun errors (OE)
- Bit errors (BE)

If all of these errors (PE, FE, BRKDT, OE, BE) are flagged, an interrupt for the flagged errors will be generated if enabled. A message is valid for both the transmitter and the receiver, if there is no error detected until the end of the frame. Each of these flags is located in the receiver status (SCIFLR) register.

There are 16 interrupt sources in the SCI/LIN module. In SCI mode, 8 interrupts are supported, as listed in [Table 13-273](#).

Table 13-273. SCI/LIN Interrupts

Offset ⁽¹⁾	Interrupt	Applicable to SCI	Applicable to LIN
0	No interrupt	-	-
1	Wakeup	Yes	Yes
2	Inconsistent-sync-field error	No	Yes
3	Parity error	Yes	Yes
4	ID	No	Yes
5	Physical bus error	No	Yes
6	Frame error	Yes	Yes
7	Break detect	Yes	No
8	Checksum error	No	Yes
9	Overrun error	Yes	Yes
10	Bit error (BE)	Yes	Yes
11	Receive	Yes	Yes
12	Transmit	Yes	Yes
13	No-response error	No	Yes
14	Timeout after wakeup signal (150 ms)	No	Yes
15	Timeout after three wakeup signals (1.5 s)	No	Yes
16	Timeout (Bus Idle, 4s)	No	Yes

(1) Offset 1 is the highest priority. Offset 16 is the lowest priority.

Table 13-274. SCI Receiver Status Flags

SCI Flag	Register	Bit	Value After Reset ⁽¹⁾
CE	SCIFLR	29	0
ISFE	SCIFLR	28	0
NRE	SCIFLR	27	0
FE	SCIFLR	26	0
OE	SCIFLR	25	0
PE	SCIFLR	24	0
RXWAKE	SCIFLR	12	0
RXRDY	SCIFLR	9	0
BUSY	SCIFLR	3	0
IDLE	SCIFLR	2	1
WAKEUP	SCIFLR	1	0
BRKDT	SCIFLR	0	0

(1) The flags are frozen with their reset value while SWnRST = 0.

Table 13-275. SCI Transmitter Status Flags

SCI Flag	Register	Bit	Value After Reset ⁽¹⁾
BE	SCIFLR	31	0
PBE	SCIFLR	30	0
TXWAKE	SCIFLR	10	0
TXEMPTY	SCIFLR	11	1
TXRDY	SCIFLR	8	1

(1) The flags are frozen with their reset value while SWnRST = 0.

13.4.2.3.3 SCI DMA Interface

DMA requests for receive (RXDMA request) and transmit (TXDMA request) are available for the SCI/LIN module. The DMA transfers depending on whether multi-buffer mode bit (MBUF MODE) is enabled or not enabled.

13.4.2.3.3.1 Receive DMA Requests

This DMA functionality is enabled/disabled by the CPU using the SET RX DMA/CLR RX DMA bits, respectively.

In Multi-Buffered SCI mode with DMA enabled, the receiver loads the RDy buffers for each received character. RX DMA request is triggered once the last character of the programmed number of characters (LENGTH) are received and copied to the corresponding RDy buffer successfully.

If the multi-buffer option is disabled, then DMA requests will be generated on a byte-per-byte basis.

In multiprocessor mode, the SCI can generate receiver interrupts for address frames and DMA requests for data frames or DMA requests for both. This is controlled by the SET RX DMA ALL bit.

In multiprocessor mode with the SLEEP bit set, no DMA is generated for received data frames. The software must clear the SLEEP bit before data frames can be received.

13.4.2.3.3.2 Transmit DMA Requests

DMA functionality is enabled/disabled by the CPU with SET TX DMA/CLR TX DMA bits, respectively.

In Multi-Buffered SCI mode once TXRDY bit is set or after a transmission of programmed number of characters (LENGTH) (up to eight data bytes stored in the transmit buffer(s) TDy in the LINTD0 and LINTD1 registers), a DMA request is generated in order to reload the transmit buffer for the next transmission. If the multi-buffer option is disabled, then DMA requests will be generated on a byte-per-byte basis.

13.4.2.3.4 SCI Configurations

Before the SCI sends or receives data, its registers should be properly configured. Upon power-up or a system-level reset, each bit in the SCI registers is set to a default state. The registers are writable only after the RESET bit in the SCIGCR0 register is set to 1. Of particular importance is the SWnRST bit in the SCIGCR1 register. The SWnRST is an active-low bit initialized to 0 and keeps the SCI in a reset state until it is programmed to 1. Therefore, all SCI configuration should be completed before a 1 is written to the SWnRST bit.

The following list details the configuration steps that software should perform prior to the transmission or reception of data. As long as the SWnRST bit is cleared to 0 the entire time that the SCI is being configured, the order in which the registers are programmed is not important.

- Enable SCI by setting the RESET bit to 1.
- Clear the SWnRST bit to 0 before SCI is configured.
- Select the desired frame format by programming the SCIGCR1 register.
- Select the baud rate to be used for communication by programming the BRS register.
- Set the CLOCK bit in SCIGCR1 to 1 to select the internal clock.
- Set the CONT bit in SCIGCR1 to 1 to make SCI not halt for an emulation breakpoint until its current reception or transmission is complete (this bit is used only in an emulation environment).
- Set the LOOP BACK bit in SCIGCR1 to 1 to connect the transmitter to the receiver internally (this feature is used to perform a self-test).
- Set the RXENA bit in SCIGCR1 to 1, if data is to be received.
- Set the TXENA bit in SCIGCR1 to 1, if data is to be transmitted.
- Set the SWnRST bit to 1 after SCI is configured.
- Perform receiving or transmitting data (see [Section 13.4.2.3.4.1](#) or [Section 13.4.2.3.4.2](#)).

13.4.2.3.4.1 Receiving Data

SCI module can receive data in one of the following modes:

- Single-Buffer (Normal) Mode
- Multi-Buffer Mode

After a valid idle period is detected, data is automatically received as it arrives on the LINRX pin.

13.4.2.3.4.1.1 Receiving Data in Single-Buffer Mode

Single-buffer mode is selected when the MBUF MODE bit in SCIGCR1 is cleared to 0. In this mode, SCI sets the RXRDY bit when it transfers newly received data from SCIRXSHF to SCIRD. The SCI clears the RXRDY bit after the new data in SCIRD has been read. Also, as data is transferred from SCIRXSHF to SCIRD, the SCI sets the FE, OE, or PE flags if any of these error conditions were detected in the received data. These error conditions are supported with configurable interrupt capability. The wake-up and break-detect status bits are also set if one of these errors occurs, but they do not necessarily occur at the same time that new data is being loaded into SCIRD.

You can receive data by:

1. Polling Receive Ready Flag
2. Receive Interrupt

In polling method, software can poll for the RXRDY bit and read the data from the SCIRD register once the RXRDY bit is set high. The CPU is unnecessarily overloaded by selecting the polling method. To avoid this, you can use To use the interrupt method, the SET RX INT bit is set.

13.4.2.3.4.1.2 Receiving Data in Multi-Buffer Mode

Multi-buffer mode is selected when the MBUFMODE bit in SCIGCR1 is set to 1. In this mode, SCI sets the RXRDY bit after receiving the programmed number of data in the receive buffer, the complete frame. The error condition detection logic is similar to the single-buffer mode, except that it monitors for the complete frame. Like single-buffer mode, you can use the polling or interrupt method to read the data. The SCI clears the RXRDY bit after the new data in SCIRD has been read.

13.4.2.3.4.2 Transmitting Data

The SCI transmitter is enabled if both the TX FUNC bit and the TXENA bit are set to 1. If the TX FUNC bit is not set, the LINTX pin functions as a general-purpose I/O pin rather than as an SCI function pin. Any value written to the SCITD before TXENA is set to 1 is not transmitted. Both of these control bits allow for the SCI transmitter to be held inactive independently of the receiver.

SCI module can transmit data in one of the following modes:

- Single-Buffer (Normal) Mode
- Multi-Buffered or Buffered SCI Mode

13.4.2.3.4.2.1 Transmitting Data in Single-Buffer Mode

Single-buffer mode is selected when the MBUF MODE bit in SCIGCR1 is cleared to 0. In this mode, SCI waits for data to be written to SCITD, transfers it to SCITXSHF, and transmits the data. The TXRDY and TX EMPTY bits indicate the status of the transmit buffers. That is, when the transmitter is ready for data to be written to SCITD, the TXRDY bit is set. Additionally, if both SCITD and SCITXSHF are empty, then the TX EMPTY bit is also set.

You can transmit data by:

1. Polling Transmit Ready Flag
2. Transmit Interrupt

In polling method, software can poll for the TXRDY bit to go high before writing the data to the SCITD register. The CPU is unnecessarily overloaded by selecting the polling method. To avoid this, you can use the interrupt method. To use the interrupt method, the SET TX INT bit is set. When the SCI has completed transmission of all pending frames, the SCITXSHF register and SCITD are empty, the TXRDY bit is set, and an interrupt request is generated, if enabled. Because all data has been transmitted, the interrupt request should be halted. This can either be done by disabling the transmit interrupt (CLR TX INT) or by disabling the transmitter (clear TXENA bit).

Note

The TXRDY flag cannot be cleared by reading the corresponding interrupt offset in the SCIINTVECT0 or SCIINTVECT1 register.

13.4.2.3.4.2.2 Transmitting Data in Multi-Buffer Mode

Multi-buffer mode is selected when the MBUF MODE bit in SCIGCR1 is set to 1. Like single-buffer mode, you can use the polling or interrupt method to write the data to be transmitted. The transmitted data has to be written to the SCITD registers. SCI waits for data to be written to the SCITD register and transfers the programmed number of bytes to SCITXSHF to transmit one by one automatically.

13.4.2.3.5 SCI Low-Power Mode

The SCI/LIN can be put in either local or global low-power mode. Global low-power mode is asserted by the system and is not controlled by the SCI/LIN. During global low-power mode, all clocks to the SCI/LIN are turned off so the module is completely inactive.

Local low-power mode is asserted by setting the POWERDOWN bit; setting this bit stops the clocks to the SCI/LIN internal logic and the module registers. Setting the POWERDOWN bit causes the SCI to enter local low-power mode and clearing the POWERDOWN bit causes SCI/LIN to exit from local low-power mode. All the registers are accessible during local power-down mode as any register access enables the clock to SCI for that particular access alone.

The wake-up interrupt is used to allow the SCI to exit low-power mode automatically when a low level is detected on the LINRX pin and also this clears the POWERDOWN bit. If wake-up interrupt is disabled, then the SCI/LIN immediately enters low-power mode whenever it is requested and also any activity on the LINRX pin does not cause the SCI to exit low-power mode.

Note

Enabling Local Low-Power Mode During Receive and Transmit

If the wake-up interrupt is enabled and low-power mode is requested while the receiver is receiving data, then the SCI immediately generates a wake-up interrupt to clear the powerdown bit and prevents the SCI from entering low-power mode and thus completes the current reception. Otherwise, if the wake-up interrupt is disabled, then the SCI completes the current reception and then enters the low-power mode.

13.4.2.3.5.1 Sleep Mode for Multiprocessor Communication

When the SCI receives data and transfers that data from SCIRXSHF to SCIRD, the RXRDY bit is set and if RX INT ENA is set, the SCI also generates an interrupt. The interrupt triggers the CPU to read the newly received frame before another one is received. In multiprocessor communication modes, this default behavior may be enhanced to provide selective indication of new data. When SCI receives an address frame that does not match its address, the device can ignore the data following this non-matching address until the next address frame by using sleep mode. Sleep mode can be used with both idle-line and address-bit multiprocessor modes.

If sleep mode is enabled by the SLEEP bit, then the SCI transfers data from SCIRXSHF to SCIRD only for address frames. Therefore, in sleep mode, all data frames are assembled in the SCIRXSHF register without being shifted into the SCIRD and without initiating a receive interrupt request. Upon reception of an address frame, the contents of the SCIRXSHF are moved into SCIRD, and the software must read SCIRD and determine if the SCI is being addressed by comparing the received address against the address previously set in the software and stored somewhere in memory (the SCI does not have hardware available for address comparison). If the SCI is being addressed, the software must clear the SLEEP bit so that the SCI will load SCIRD with the data of the data frames that follow the address frame.

When the SCI has been addressed and sleep mode has been disabled (in software) to allow the receipt of data, the SCI should check the RXWAKE bit (SCIFLR.12) to determine when the next address has been received. This bit is set to 1 if the current value in SCIRD is an address and set to 0 if SCIRD contains data. If the RXWAKE bit is set, then software should check the address in SCIRD against its own address. If it is still being addressed, then sleep mode should remain disabled. Otherwise, the SLEEP bit should be set again.

Following is a sequence of events typical of sleep mode operation:

- The SCI is configured and both sleep mode and receive actions are enabled.
- An address frame is received and a receive interrupt is generated.
- Software compares the received address frame against that set by software and determines that the SCI is not being addressed, so the value of the SLEEP bit is not changed.
- Several data frames are shifted into SCIRXSHF, but no data is moved to SCIRD and no receive interrupts are generated.
- A new address frame is received and a receive interrupt is generated.
- Software compares the received address frame against that set by software and determines that the SCI is being addressed and clears the SLEEP bit.
- Data shifted into SCIRXSHF is transferred to SCIRD, and a receive interrupt is generated after each data frame is received.
- In each interrupt routine, software checks RXWAKE to determine if the current frame is an address frame.
- Another address frame is received, RXWAKE is set, software determines that the SCI is not being addressed and sets the SLEEP bit back to 1. No receive interrupts are generated for the data frames following this address frame.

By ignoring data frames that are not intended for the device, fewer interrupts are generated. These interrupts would otherwise require CPU intervention to read data that is of no significance to this specific device. Using sleep mode can help free some CPU resources.

Except for the RXRDY flag, the SCI continues to update the receiver status flags (see [Table 13-274](#)) while sleep mode is active. In this way, if an error occurs on the receive line, an application can immediately respond to the error and take the appropriate corrective action.

Because the RXRDY bit is not updated for data frames when sleep mode is enabled, the SCI can enable sleep mode and use a polling algorithm if desired. In this case, when RXRDY is set, software knows that a new address has been received. If the SCI is not being addressed, then the software should not change the value of the SLEEP bit and should continue to poll RXRDY.

13.4.2.4 Local Interconnect Network Module

13.4.2.4.1 LIN Communication Formats

The SCI/LIN module can be used in LIN mode or SCI mode. The enhancements for baud generation and additional receive/transmit buffers necessary for LIN mode operation are also part of the enhanced buffered SCI module. LIN mode is selected by enabling LIN MODE bit in SCIGCR1 register.

Note

The SCI/LIN is built around the SCI platform and uses a similar sampling scheme: 16 samples for each bit with majority vote on samples 8, 9, and 10. For the START bit, the first three samples are used.

The SCI/LIN control registers are located at the SCI/LIN base address.

13.4.2.4.1.1 LIN Standards

For compatibility with LIN2.0 standard the following additional features are implemented over LIN1.3:

1. Support for LIN 2.0 checksum
2. Enhanced synchronizer FSM support for frame processing
3. Enhanced handling of extended frames
4. Enhanced baud rate generator
5. Update wakeup/go to sleep

The LIN module covers the CPU performance-consuming features, defined in the *LIN Specification Package* Revision 1.3 and 2.0 by hardware.

13.4.2.4.1.2 Message Frame

The LIN protocol defines a message frame format, shown in Figure 13-254. Each frame includes one commander header, one response, one in-frame response space, and inter-byte spaces. In-frame-response and inter-byte spaces may be 0.

There is no arbitration in the definition of the LIN protocol; therefore, multiple responder nodes responding to a header might be detected as an error.

The LIN bus is a single-channel wired-AND bus. The bus has a binary level: either dominant for a value of 0 or recessive for a value of 1.

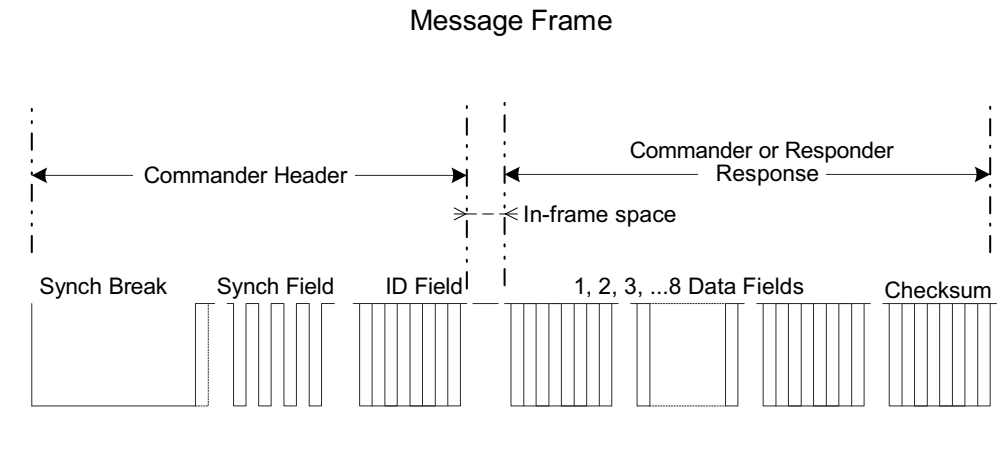

Figure 13-254. LIN Protocol Message Frame Format: Commander Header and Responder Peripheral Response

13.4.2.4.1.2.1 Message Header

The header of a message is initiated by a commander (see Figure 13-255) and consists of a three field-sequence:

- The synchronization break field signaling the beginning of a message
- The synchronization field conveying bit rate information of the LIN bus
- The identification field denoting the content of a message

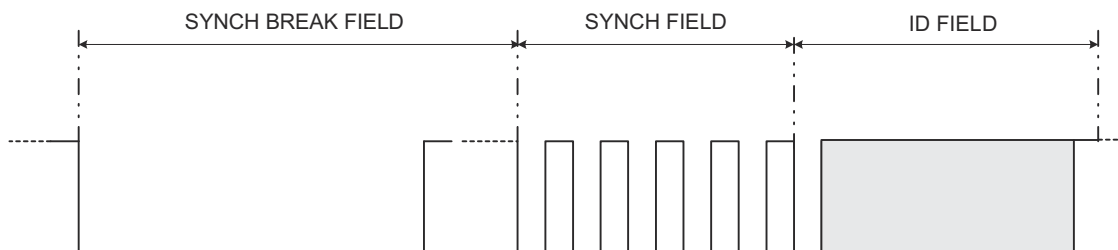

Figure 13-255. Header 3 Fields: Synch Break, Synch, and ID

13.4.2.4.1.2.2 Response

The format of the response is as illustrated in [Figure 13-256](#). There are two types of fields in a response: data and checksum. The data field consists of exactly one data byte, one start bit, and one stop bit, for a total of 10 bits. The LSB is transmitted first. The checksum field consists of one checksum byte, one start bit and one stop bit. The checksum byte is the inverted modulo-256 sum over all data bytes in the data fields of the response.

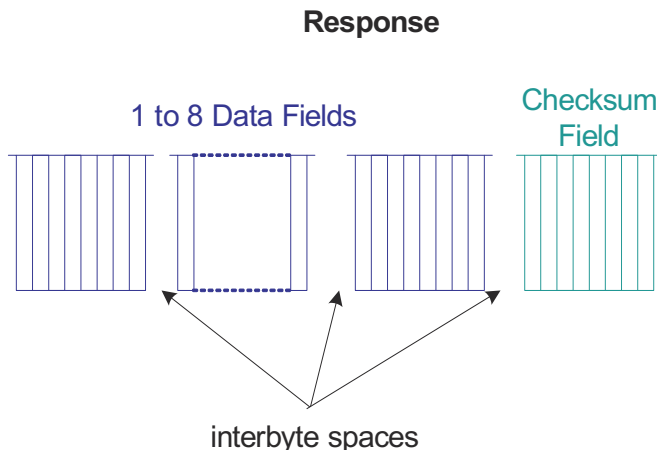

Figure 13-256. Response Format of LIN Message Frame

The format of the response is a stream of N data fields and one checksum field. Typically N is from 1 to 8, with the exception of the extended command frames ([Section 13.4.2.4.1.6](#)). The length N of the response is indicated either with the optional length control bits of the ID Field (this is used in standards earlier than LIN 1.x); see [Table 13-276](#), or by LENGTH value in SCIFORMAT[18:16] register; see [Table 13-277](#). The SCI/LIN module supports response lengths from 1 to 8 bytes in compliance with LIN 2.0.

Table 13-276. Response Length Info Using IDBYTE Field Bits [5:4] for LIN Standards Earlier than v1.3

ID5	ID4	Number of Data Bytes
0	0	2
0	1	2
1	0	4
1	1	8

Table 13-277. Response Length with SCIFORMAT[18:16] Programming

SCIFORMAT[18:16]	Number of Bytes
000	1
001	2
010	3
011	4
100	5
101	6
110	7
111	8

13.4.2.4.1.3 Synchronizer

The synchronizer has three major functions in the messaging between commander and responder nodes. It generates the commander header data stream, it synchronizes to the LIN bus for responding, and it locally detects timeouts. A bit rate is programmed using the prescalers in the BRSR register to match the indicated LIN_speed value in the LIN description file.

The LIN synchronizer will perform the following functions: commander header signal generation, responder detection and synchronization to message header with optional baud rate adjustment, response transmission timing and timeout control.

The LIN synchronizer is capable of detecting an incoming break and initializing communication at all times.

13.4.2.4.1.4 Baud Rate

The transmission baud rate of any node is configured by the CPU at the beginning; this defines the bit time T_{bit} . The bit time is derived from the fields P and M in the baud rate selection register (BRSR).

The ranges for the prescaler values in the BRSR register are:

$$P = 0, 1, 2, 3, \dots, 2^{24} - 1$$

$$M = 0, 1, 2, \dots, 15$$

The P values in the BRSR register are user programmable. The P and M dividers could be used for both SCI mode and LIN mode to select a baud rate. If the ADAPT bit is set and the LIN peripheral is in adaptive baud rate mode, then all these divider values are automatically obtained during header reception when the synchronization field is measured.

The LIN protocol defines baud rate boundaries as follows:

$$1 \text{ kHz} \leq F_{LINCLK} \leq 20 \text{ kHz}$$

All transmitted bits are shifted in and out at T_{bit} periods.

13.4.2.4.1.4.1 Fractional Divider

The M field of the BRSR register modifies the integer prescaler P for fine tuning of the baud rate. The M value adds in increments of 1/16 of the P value.

The bit time, T_{bit} is expressed in terms of the VCLK period T_{VCLK} as follows:

For all P other than 0, and all M,

$$T_{bit} = 16 \left(P + 1 + \frac{M}{16} \right) T_{VCLK}$$

For P= 0 : $T_{bit} = 32T_{VCLK}$

Therefore, the LINCLK frequency is given by:

$$F_{\text{LINCLK}} = \frac{F_{\text{VCLK}}}{16(P+1 + \frac{M}{16})} \quad \text{For all } P \text{ other than zero}$$

$$F_{\text{LINCLK}} = \frac{F_{\text{VCLK}}}{32} \quad \text{For } P = 0$$

13.4.2.4.1.5 Header Generation

Automatic generation of the LIN protocol header data stream is supported without CPU interaction. The CPU triggers a message header generation and the LIN state machine handles the generation itself. A commander node initiates header generation on the CPU writes to the IDBYTE in the LINID register. The header is always sent by the commander to initiate a LIN communication and consists of three fields: synchronization break field, synchronization field, and identification field, as seen in [Figure 13-257](#).

Note

The LIN protocol uses the parity bits in the identifier. The control length bits are optional to the LIN protocol.

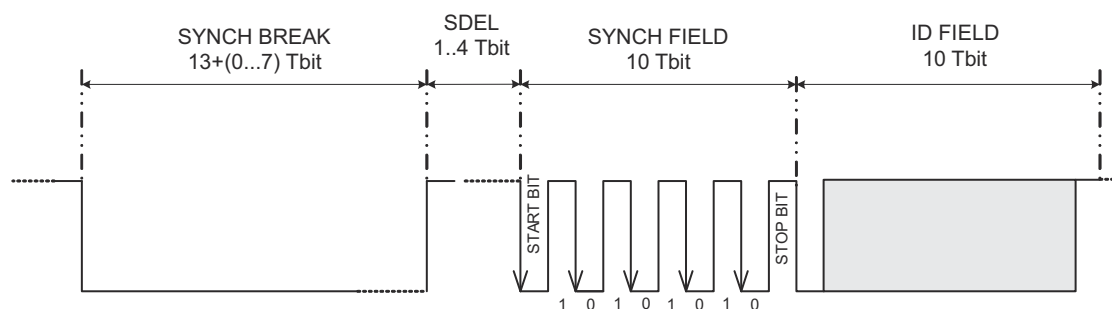

Figure 13-257. Message Header in Terms of T_{bit}

- The break field consists of two components:
 - The synchronization break (SYNCH BREAK) consists of a minimum of 13 (dominant) low bits to a maximum of 20 dominant bits. The sync break length may be extended from the minimum with the 3-bit SBREAK value in the LINCOMP register.
 - The synchronization break delimiter (SDEL) consists of a minimum of 1 (recessive) high bit to a maximum of 4 recessive bits. The delimiter marks the end of the synchronization break field. The sync break delimiter length depends on the 2-bit SDEL value in the LINCOMP register.
- The synchronization field (SYNCH FIELD) consists of one start bit, byte 0x55, and a stop bit. It is used to convey T_{bit} information and resynchronize LIN bus nodes.
- The identifier field ID byte may use 6 bits as an identifier, with optional length control and two optional bits as parity of the identifier. The identifier parity is used and checked if the PARITY ENA bit is set. If length control bits are not used, then there can be a total of 64 identifiers plus parity. If neither length control or parity are used there can be up to 256 identifiers. See [Figure 13-258](#) for an illustration of the ID field.

Note

Optional Control Length Bits

The control length bits only apply to LIN standards prior to LIN 1.3. IDBYTE field conveys response length information if compliant to standards earlier than LIN1.3. The SCIFORMAT register stores the length of the response for later versions of the LIN protocol.

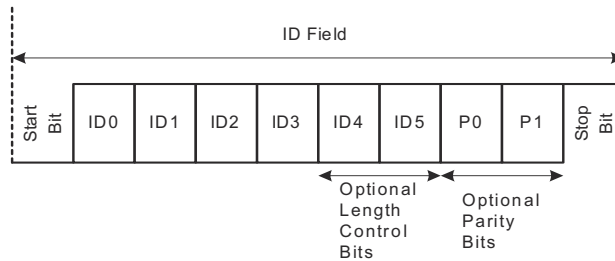

Figure 13-258. ID Field

Note

If the LIN module, configured as a responder in multi-buffer mode, is in the process of transmitting data while a new header comes in, the module might end up in responding with the data from the previous interrupted response (not the data corresponding to the new ID). To avoid this scenario the following procedure could be used:

1. Check for the Bit Error (BE) during the response transmission. If the BE flag is set, this indicates that a collision has happened on the LIN bus (here because of the new Synch Break).
2. In the Bit Error ISR, configure the TD0 and TD1 registers with the next set of data to be transmitted on a TX Match for the incoming ID. Before writing to TD0/TD1 make sure that there was not already an update because of a Bit Error; otherwise, TD0/TD1 might be written twice for one ID.
3. Once the complete ID is received, based on the match, the newly configured data will be transmitted by the node.

13.4.2.4.1.5.1 Event Triggered Frame Handling

The LIN 2.0 protocol uses event-triggered frames that may occasionally cause collisions. Event-triggered frames have to be handled in software.

If no responder answers to an event triggered frame header, the commander node sets the NRE flag, and a NRE interrupt occurs if enabled. If a collision occurs, a frame error and checksum error may arise before the NRE error. Those errors are flagged and the appropriate interrupts occur, if enabled.

Frame errors and checksum errors depend on the behavior and synchronization of the responding responders. If the responders are totally synchronized and stop transmission once the collision occurred, it is possible that only the NRE error is flagged despite the occurrence of a collision. To detect if there has been a reception of one byte before the NRE error is flagged, the BUS BUSY flag can be used as an indicator.

The BUS BUSY flag is set on the reception of the first bit of the header and remains set until the header reception is complete, and again is set on the reception of the first bit of the response. In the case of a collision, the flag is cleared in the same cycle as the NRE flag is set.

Software could implement the following sequence:

- Once the reception of the header is done (poll for RXID flag), wait for the BUS BUSY flag to get set or NRE flag to get set.
- If BUS BUSY flag is not set before NRE flag, then it is a true no response case (no data has been transmitted onto the bus).
- If BUS BUSY flag gets set, then wait for NRE flag to get set or for successful reception. If NRE flag is set, then in this case a collision has occurred on the bus.

Even in the case of a collision, the received (corrupted) data is accessible in the RX buffers; registers LINRD0 and LINRD1.

13.4.2.4.1.5.2 Header Reception and Adaptive Baud Rate

A responder node baud rate can optionally be adjusted to the detected bit rate as an option to the LIN module. The adaptive baud rate option is enabled by setting the ADAPT bit. During header reception, a responder measures the baud rate during detection of the synch field. If ADAPT bit is set, then the measured baud rate is compared to the responder node programmed baud rate and adjusted to the LIN bus baud rate if necessary.

The LIN synchronizer determines two measurements: BRK_count and BAUD_count (Figure 13-259). These values are always calculated during the Header reception for synch field validation (Figure 13-260).

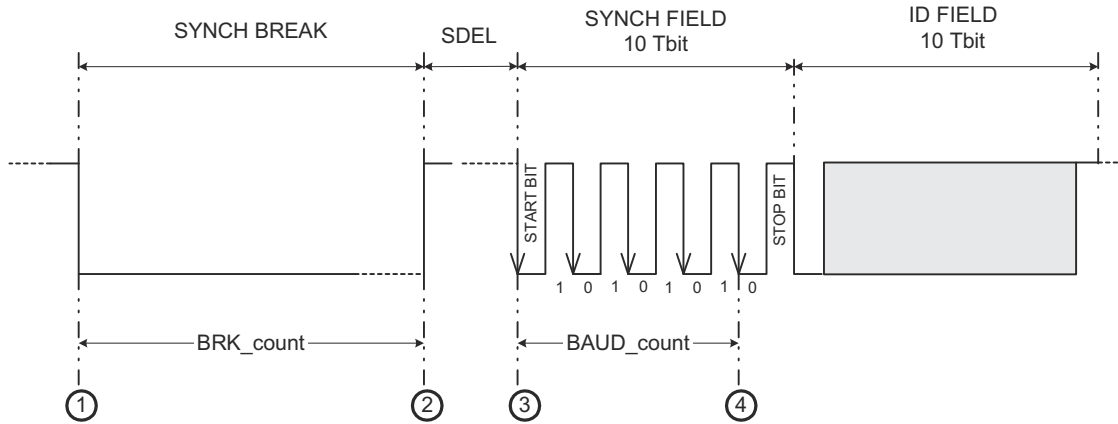

Figure 13-259. Measurements for Synchronization

By measuring the values BRK_count and BAUD_count, a valid sync break sequence can be detected as described in Figure 13-260. The four numbered events in Figure 13-259 signal the start/stop of the synchronizer counter. The synchronizer counter uses VCLK as the time base.

The synchronizer counter is used to measure the sync break relative to the detecting node T_{bit} . For a responder node receiving the sync break, a threshold of $11 T_{bit}$ is used as required by the LIN protocol. For detection of the dominant data stream of the sync break, the synchronizer counter is started on a falling edge and stopped on a rising edge of the LINRX. On detection of the sync break delimiter, the synchronizer counter value is saved and then reset.

On detection of five consecutive falling edges, the BAUD_count is measured. Bit timing calculation and consistency to required accuracy is implemented following the recommendations of LIN revision 2.0. A responder node can calculate a single T_{bit} time by division of BAUD_count by 8. In addition, for consistency between the detected edges the following is evaluated:

$$BAUD_count + BAUD_count \gg 2 + BAUD_count \gg 3 \leq BRK_count$$

The BAUD_count value is shifted 3 times to the right and rounded using the first insignificant bit to obtain a T_{bit} unit. If the ADAPT bit is set, then the detected baud rate is compared to the programmed baud rate.

During the header reception processing as illustrated in Figure 13-260, if the measured BRK_count value is less than $11 T_{bit}$, the sync break is not valid according to the protocol for a fixed rate. If the ADAPT bit is set, then the MBRS register is used for measuring BRK_count and BAUD_count values and automatically adjusts to any allowed LIN bus rate (refer to LIN Specification Package 2.0).

Note

In adaptive mode, the MBRS divider should be set to allow a maximum baud rate that is not more than 10% above the expected operating baud rate in the LIN network. Otherwise, a 0x00 data byte could mistakenly be detected as a sync break.

The break-threshold relative to the responder node is $11 T_{bit}$. The break is $13 T_{bit}$ as specified in LIN v1.3.

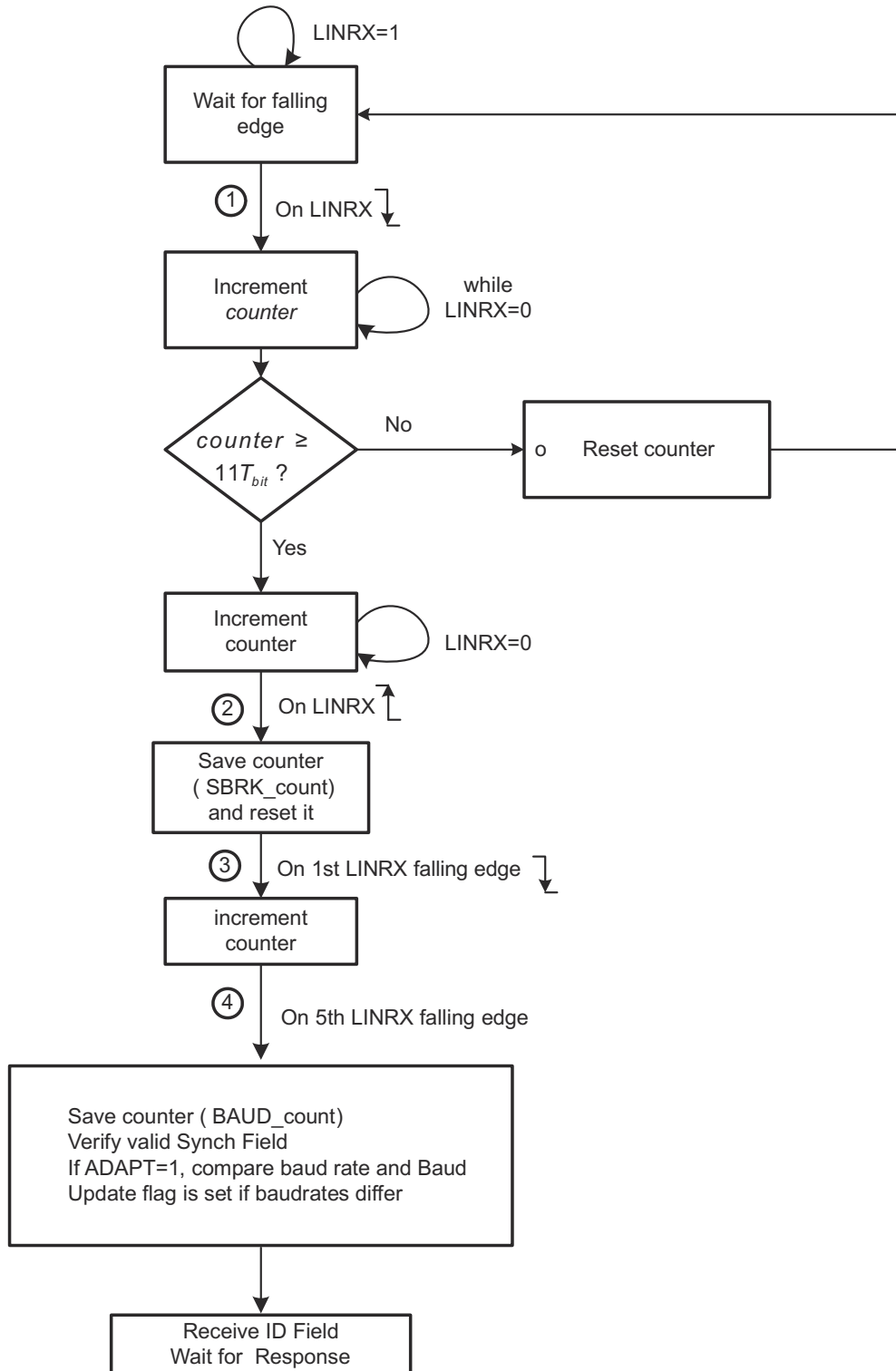

Figure 13-260. Synchronization Validation Process and Baud Rate Adjustment

If the synch field is not detected within the given tolerances, the inconsistent-sync-field-error (ISFE) flag will be set. An ISFE interrupt will be generated, if enabled by its respective bit in the SCISSETINT register. The ID byte should be received after the synch field validation was successful. Any time a valid break (larger than $11 T_{bit}$) is detected, the receiver state machine should reset to reception of this new frame. This reset condition is only valid during response state, not if an additional synch break occurs during header reception.

Note

When an inconsistent synch field (ISFE) error occurs, suggested action for the application is to reset the SWnRST bit and set the SWnRST bit to make sure that the internal state machines are back to their normal states.

13.4.2.4.1.6 Extended Frames Handling

The LIN protocol 2.0 and prior includes two extended frames with identifiers 62 (user-defined) and 63 (reserved extended). The response data length of the user-defined frame (ID 62, or 0x3E) is unlimited. The length for this identifier will be set at network configuration time to be shared with the LIN bus nodes.

Extended frame communication is triggered on reception of a header with identifier 0x3E; see [Figure 13-261](#). Once the extended frame communication is triggered, unlike normal frames, this communication needs to be stopped before issuing another header. To stop the extended frame communication the STOP EXT FRAME bit must be set.

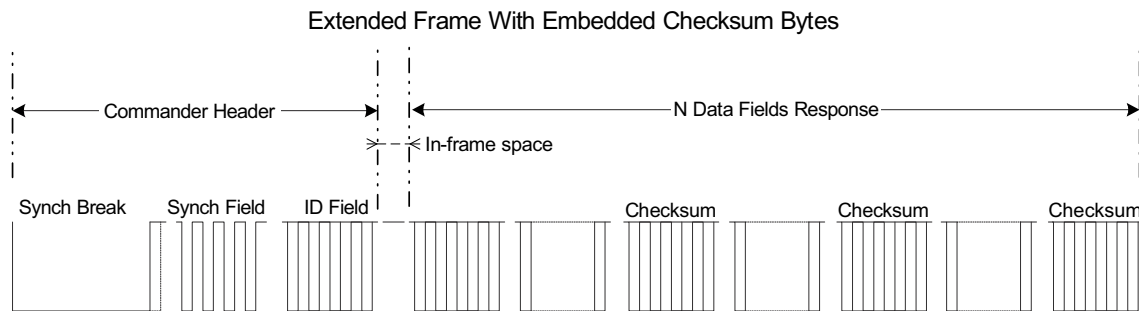

Figure 13-261. Optional Embedded Checksum in Response for Extended Frames

An ID interrupt will be generated (if enabled and there is a match) on reception of ID 62 (0x3E). This interrupt allows the CPU using a software counter to keep track of the bytes that are being sent out and decides when to calculate and insert a checksum byte (recommended at periodic rates). To handle this procedure, SC bit is used. A write to the send checksum bit SC will initiate an automatic send of the checksum byte. The last data field should always be a checksum in compliance with the LIN protocol.

The periodicity of the checksum insertion, defined at network configuration time, is used by the receiving node to evaluate the checksum of the ongoing message, and has the benefit of enhanced reliability.

For the sending node, the checksum is automatically embedded each time the send checksum bit SC is set. For the receiving node, the checksum is compared each time the compare checksum bit CC is set; see [Figure 13-262](#).

Note

The LIN 2.0 enhanced checksum does not apply to the reserved identifiers. The reserved identifiers always use the classic checksum.

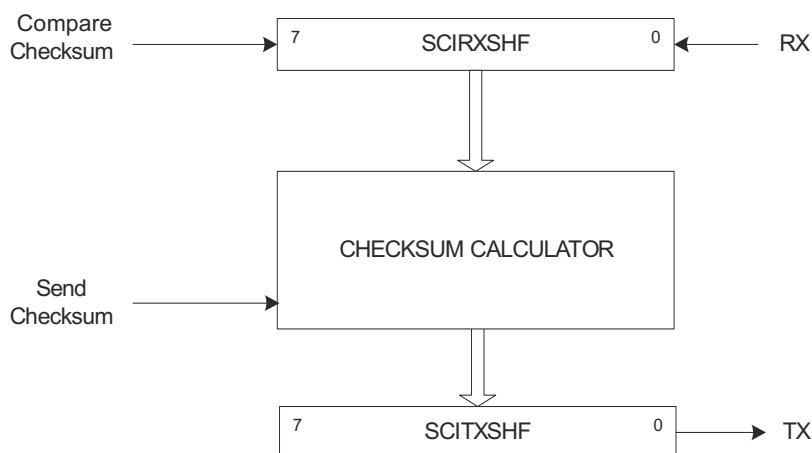

Figure 13-262. Checksum Compare and Send for Extended Frames

13.4.2.4.1.7 Timeout Control

Any LIN node listening to the bus and expecting a response initiated from a commander node could flag a no-response error timeout event. The LIN protocol defines four types of timeout events, which are all handled by the hardware of the LIN module. The four LIN protocol events are:

- No-response timeout error
- Bus idle detection
- Timeout after wakeup signal
- Timeout after three wakeup signals

13.4.2.4.1.7.1 No-Response Error (NRE)

The no-response error occurs when any node expecting a response waits for $T_{\text{FRAME_MAX}}$ time and the message frame is not fully completed within the maximum length allowed, $T_{\text{FRAME_MAX}}$. After this time, a no-response error (NRE) is flagged in the NRE bit of the SCIFLW register. An interrupt is triggered, if enabled.

As specified in the LIN 1.3 standard, the minimum time to transmit a frame is:

$$T_{\text{FRAME_MIN}} = T_{\text{HEADER_MIN}} + T_{\text{DATA_FIELD}} + T_{\text{CHECKSUM_FIELD}} = 44 + 10N$$

where N = number of data fields.

And the maximum time frame is given by:

$$T_{\text{FRAME_MAX}} = T_{\text{FRAME_MIN}} * 1.4 = (44 + 10N) * 1.4$$

The timeout value $T_{\text{FRAME_MAX}}$ is derived from the N number of data fields value, see [Table 13-278](#). The N value is either embedded in the header ID field for messages or is part of the description file. In the latter case, the 3-bit CHAR value in SCIFORMAT register indicates the value for N .

Note

The length coding of the ID field does not apply to two extended frame identifiers, ID fields of 0x3E (62) and 0x3F (63). In these cases, the ID field can be followed by an arbitrary number of data byte fields. Also, the LIN 2.0 protocol specification mentions that ID field 0x3F (63) cannot be used. For these two cases, the NRE will not be handled by the LIN hardware.

Table 13-278. Timeout Values in T_{bit} Units

N	T_{DATA_FIELD}	T_{FRAME_MIN}	T_{FRAME_MAX}
1	10	54	76
2	20	64	90
3	30	74	104
4	40	84	118
5	50	94	132
6	60	104	146
7	70	114	160
8	80	124	174

13.4.2.4.1.7.2 Bus Idle Detection

The second type of timeout can occur when a node detects an inactive LIN bus: no transitions between recessive and dominant values are detected on the bus. This happens after a minimum of 4 s (this is 80,000 F_{LINCLK} cycles with the fastest bus rate of 20 kbps). If a node detects no activity in the bus as the TIMEOUT bit is set, then it can be assumed that the LIN bus is in sleep mode. Application software can use the Timeout flag to determine when the LIN bus is inactive and put the LIN into sleep mode by writing the POWERDOWN bit.

Note

After the timeout was flagged, a SWnRESET should be asserted before entering Low-Power Mode. This is required to reset the receiver in case that an incomplete frame was on the bus before the idle period.

13.4.2.4.1.7.3 Timeout After Wakeup Signal and Timeout After Three Wakeup Signals

The third and fourth types of timeout are related to the wakeup signal. A node initiating a wakeup should expect a header from the commander within a defined amount of time: timeout after wakeup signal. See [Section 13.4.2.5.3](#) for more details.

13.4.2.4.1.8 TXRX Error Detector (TED)

The following sources of error are detected by the TXRX error detector logic (TED). The TED logic consists of a bit monitor, an ID parity checker, and a checksum error. The following errors are detected:

- Bit errors (BE)
- Physical bus errors (PBE)
- Identifier parity errors (PE)
- Checksum errors (CE)

All of these errors (BE, PBE, PE, CE) are flagged. An interrupt for the flagged errors will be generated if enabled. A message is valid for both the transmitter and the receiver if there is no error detected until the end of the frame.

13.4.2.4.1.8.1 Bit Errors

A bit error (BE) is detected at the bit time when the bit value that is monitored is different from the bit value that is sent. A bit error is indicated by the BE flag in SCIFLR. After signaling a BE, the transmission is aborted no later than the next byte. The bit monitor ensures that the transmitted bit in LINTX is the correct value on the LIN bus by reading back on the LINRX pin as shown in Figure 13-263.

Note

If a bit occurs due to receiving a header during a responder response, NRE/TIMEOUT flag will not be set for the new frame.

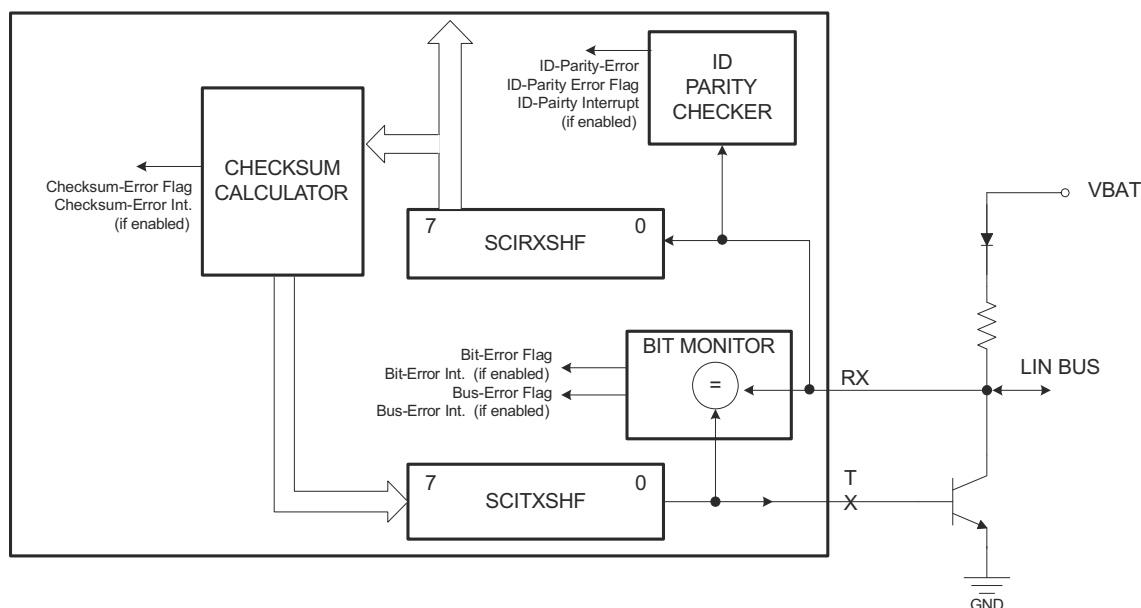

Figure 13-263. TXRX Error Detector

13.4.2.4.1.8.2 Physical Bus Errors

A Physical Bus Error (PBE) has to be detected by a commander, if no valid message can be generated on the bus (bus shorted to GND or VBAT). The bit monitor detects a PBE during the header transmission, if no Synch Break can be generated (for example, because of a bus shortage to VBAT) or if no Synch Break delimiter can be generated (for example, because of a bus shortage to GND). Once the Sync Break Delimiter was validated, all other deviations between the monitored and the sent bit value are flagged as Bit Errors (BE) for this frame.

13.4.2.4.1.8.3 ID Parity Errors

If parity is enabled, an ID parity error (PE) is detected if any of the two parity bits of the sent ID byte are not equal to the calculated parity on the receiver node. The two parity bits are generated using the following mixed parity algorithm:

$$P0 = ID0 \oplus ID1 \oplus ID2 \oplus ID4 \text{ (even Parity)}$$

$$P1 = ID1 \oplus ID3 \oplus ID4 \oplus ID5 \text{ (odd Parity)}$$

If an ID-parity error is detected, the ID-parity error is flagged, and the received ID is not valid. See Section 13.4.2.4.1.9 for details.

13.4.2.4.1.8.4 Checksum Errors

A checksum error (CE) is detected and flagged at the receiving end if the calculated modulo-256 sum over all received data bytes (including the ID byte if it is the enhanced checksum type) plus the checksum byte does not result in 0xFF. The modulo-256 sum is calculated over each byte by adding with carry, where the carry bit of each addition is added to the LSB of its resulting sum.

For the transmitting node, the checksum byte sent at the end of a message is the inverted sum of all the data bytes (see Figure 13-264) for classic checksum implementation. The checksum byte is the inverted sum of the identifier byte and all the data bytes (see Figure 13-265) for the LIN 2.0 compliant enhanced checksum implementation. The classic checksum implementation should always be used for reserved identifiers 60 to 63; therefore, the CTYPE bit will be overridden in this case. For signal-carrying-frame identifiers (0 to 59) the type of checksum used depends on the CTYPE bit.

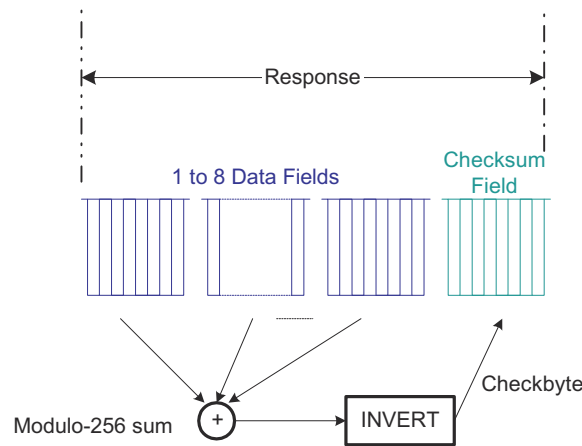

Figure 13-264. Classic Checksum Generation at Transmitting Node

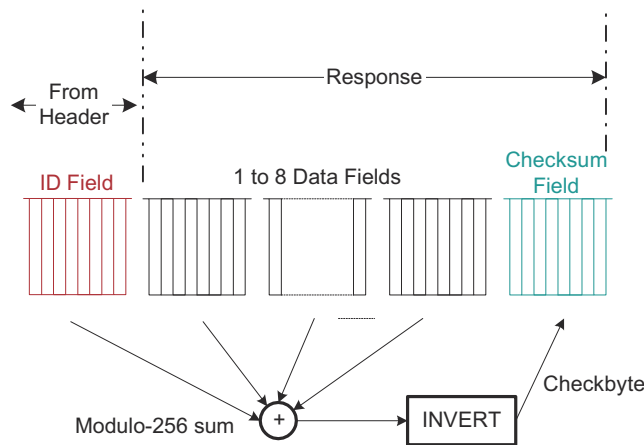

Figure 13-265. LIN 2.0-Compliant Checksum Generation at Transmitting Node

13.4.2.4.1.9 Message Filtering and Validation

Message filtering uses the entire identifier to determine which nodes will participate in a response, either receiving or transmitting a response. Therefore, two acceptance masks are used as shown in Figure 13-266. During header reception, all nodes filter the ID-Field (ID-Field is the part of the header explained in Figure 13-258) to determine whether they transmit a response or receive a response for the current message. There are two masks for message ID filtering: one to accept a response reception, the other to initiate a response transmission. See Figure 13-266. All nodes compare the received ID to the identifier stored in the ID-SlaveTask BYTE of the LINID register and use the RX ID MASK and the TX ID MASK fields in the LINMASK register to filter the bits of the identifier that should not be compared.

If there is an RX match with no parity error and the RXENA bit is set, there will be an ID RX flag and an interrupt will be triggered if enabled. If there is a TX match with no parity error and the TXENA bit is set, there will be an ID TX flag and an interrupt will be triggered if enabled in the SCISSETINT register.

The masked bits become don't cares for the comparison. To build a mask for a set of identifiers, an XOR function could be used.

ADVANCE INFORMATION

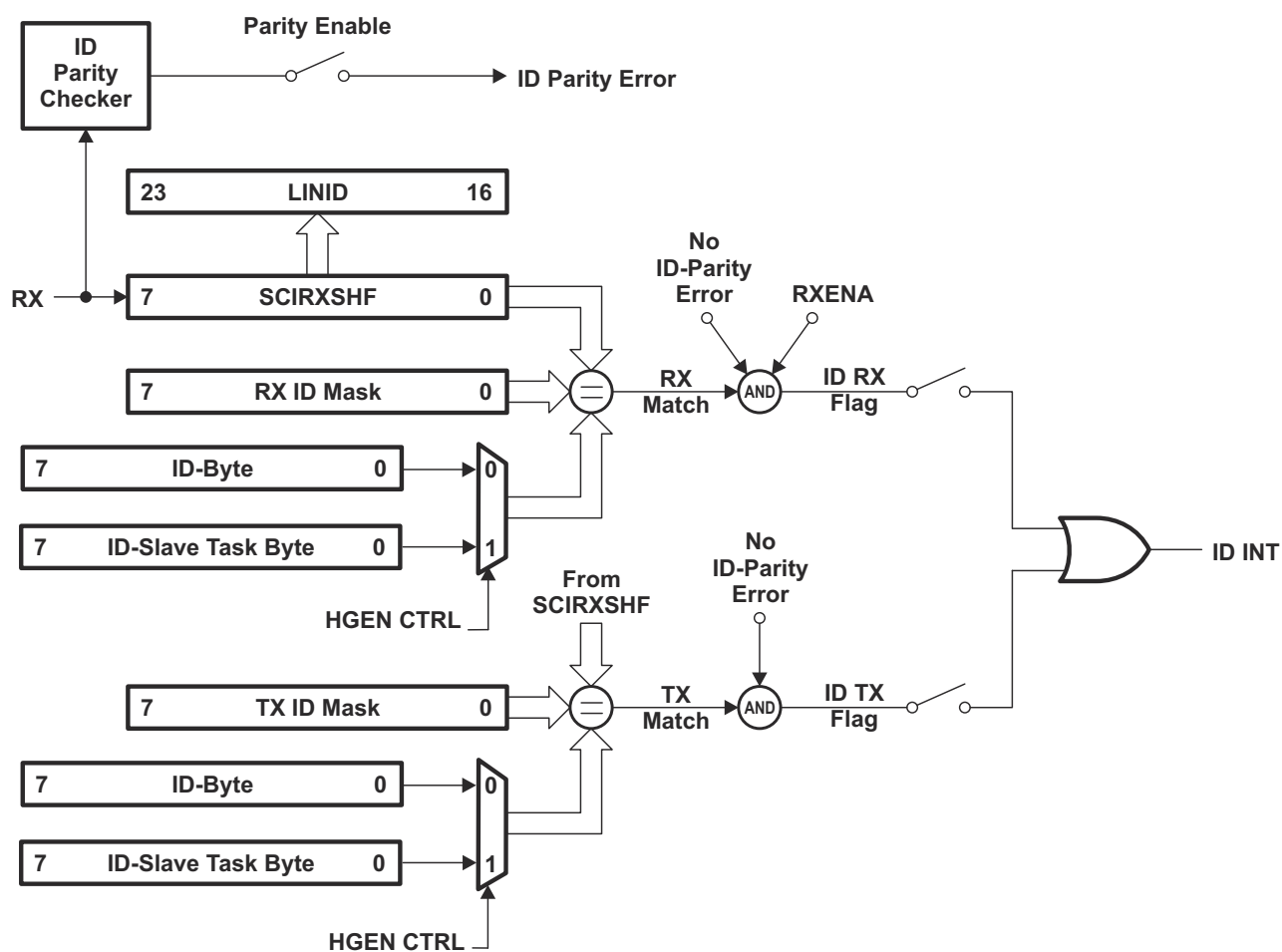

Figure 13-266. ID Reception, Filtering and Validation

For example, to build a mask to accept IDs 0x26 and 0x25 using LINID[7:0] = 0x20; that is, compare 5 most-significant bits (MSBs) and filter 3 least-significant bits (LSBs), the acceptance mask could be:

$$(0x26 + 0x25) \oplus 0x20 = 0x07$$

A mask of all zeros will compare all bits of the received identifier in the shift register with the ID-BYTE in LINID[7:0]. If HGEN CTRL is set to 1, a mask of 0xFF will always cause a match. A mask of all 1s will filter all bits of the received identifier, and thus there will be an ID match regardless of the content of the ID-SlaveTask BYTE field in the LINID register.

Note

When the HGEN CTRL bit = 0, the LIN nodes compare the received ID to the ID-BYTE field in the LINID register, and use the RX ID MASK and the TX ID MASK in the LINMASK register to filter the bits of the identifier that should not be compared.

If there is an RX match with no parity error and the RXENA bit is set, there will be an ID RX flag and an interrupt will be triggered if enabled. A mask of all 0s will compare all bits of the received identifier in the shift register with the ID-BYTE field in LINID[7:0]. A mask of all 1s will filter all bits of the received identifier and there will be no match.

If HGEN CTRL = 1:

- Received ID is compared with the ID-Slave-Task byte, using the RXID mask and the TXID mask.
- A mask of all ones will always result in a match.
- A mask of all zeroes means all the bits must be the same to result in a match.
- If a mask has some bits which are ones, then those bits will not be used for the filtering criterion.

If HGEN CTRL = 0:

- Received ID is compared with the ID byte, using the RXID mask and the TXID mask.
- A mask of all ones will result in no match.
- A mask of all zeroes means all the bits must be the same to result in a match.
- If a mask has some bits which are ones, then those bits will not be used for the filtering criterion.

During header reception, the received identifier is copied to the Received ID field LINID[23:16]. If there is no parity error and there is either a TX match or an RX match, then the corresponding TX or RX ID flag is set. If the ID interrupt is enabled, then an ID interrupt is generated.

After the ID interrupt is generated, the CPU may read the Received ID field LINID[23:16] and determine what response to load into the transmit buffers.

Note

When byte 0 is written to TD0 (LINTD0[31:24]), the response transmission is automatically generated.

In multi-buffer mode, the TXRDY flag will be set when all the response data bytes and checksum byte are copied to the shift register SCITXSHF. In non-multibuffer mode, the TXRDY flag is set each time a byte is copied to the SCITXSHF register, and also for the last byte of the frame after the checksum byte is copied to the SCITXSHF register.

In multi-buffer mode, the TXEMPTY flag is set when both the transmit buffer(s) TDy and the SCITXSHF shift register are emptied and the checksum has been sent. In non-multibuffer mode, TXEMPTY is set each time TD0 and SCITXSHF are emptied, except for the last byte of the frame where the checksum byte must also be transmitted.

If parity is enabled, all responder receiving nodes will validate the identifier using all eight bits of the received ID byte. The SCI/LIN will flag a corrupted identifier if an ID-parity error is detected.

13.4.2.4.1.10 Receive Buffers

To reduce CPU load when receiving a LIN N-byte (with N = 1–8) response in interrupt mode, the SCI/LIN module has eight receive buffers. These buffers can store an entire LIN response in the RDy receive buffers. [Figure 13-250](#) illustrates the receive buffers.

The checksum byte following the data bytes is validated by the internal checksum calculator. The checksum error (CE) flag indicates a checksum error and a CE interrupt will be generated if enabled in the SCISSETINT register.

The multi-buffer 3-bit counter counts the data bytes transferred from the SCIRXSHF register to the RDy receive buffers if multi-buffer mode is enabled, or to RD0 if multi-buffer mode is disabled. The 3-bit compare register contains the number of data bytes expected to be received. In cases where the ID BYTE field does not convey message length (see *Note: Optional Control Length Bits* in [Section 13.4.2.4.1.5](#)), the LENGTH value, indicates the expected length and is used to load the 3-bit compare register. Whether the length control field or the LENGTH value is used is selectable with the COMM MODE bit.

A receive interrupt, and a receive ready RXRDY flag could occur after receiving a response if there are no response receive errors for the frame (such as, there is no checksum error, frame error, and overrun error). The checksum byte will be compared before acknowledging a reception.

Note

In multi-buffer mode following are the scenarios associated with clearing the "RXRDY" flag bit:

1. The RXRDY flag cannot be cleared by reading the corresponding interrupt offset in the SCIINTVECT0/1 register.
 2. For LENGTH less than or equal to 4, Read to RD0 register will clear the "RXRDY" flag.
 3. For LENGTH greater than 4, Read to RD1 register will clear the "RXRDY" flag.
-

13.4.2.4.1.11 Transmit Buffers

To reduce the CPU load when transmitting a LIN N-byte (with N = 1–8) response in interrupt mode, the SCI/LIN module has 8 transmit buffers, TD0–TD7 in LINTD0 and LINTD1. With these transmit buffers, an entire LIN response field can be preloaded in the TXy transmit buffers. [Figure 13-251](#) illustrates the transmit buffers.

The multi-buffer 3-bit counter counts the data bytes transferred from the TDy transmit buffers register if multi-buffer mode is enabled, or from TD0 to SCITXSHF if multi-buffer mode is disabled. The 3-bit compare register contains the number of data bytes expected to be transmitted. If the ID field is not used to convey message length (see *Note: Optional Control Length Bits* in [Section 13.4.2.4.1.5](#)), the LENGTH value indicates the expected length and is used instead to load the 3-bit compare register. Whether the length control field or the LENGTH value is used is selectable with the COMM MODE bit.

A transmit interrupt (TX interrupt) and a transmit ready flag (TXRDY flag) can occur after transmitting a response.

The checksum byte is automatically generated by the checksum calculator and sent after the data-fields transmission is finished. The multi-buffer 3-bit counter counts the data bytes transferred from the TDy buffers into the SCITXSHF register.

Note

The transmit interrupt request can be eliminated until the next series of data is written into the transmit buffers LINTD0 and LINTD1, by disabling the corresponding interrupt using the SCICLRINT register or by disabling the transmitter via the TXENA bit.

13.4.2.4.2 LIN Interrupts

LIN and SCI modes have a common interrupt block, as explained in [Section 13.4.2.3.2](#). There are 16 interrupt sources in the SCI/LIN module, with 8 of them being LIN mode only, as seen in [Table 13-273](#).

A LIN message frame indicating the timing and sequence of the LIN interrupts that could occur is shown in [Figure 13-267](#).

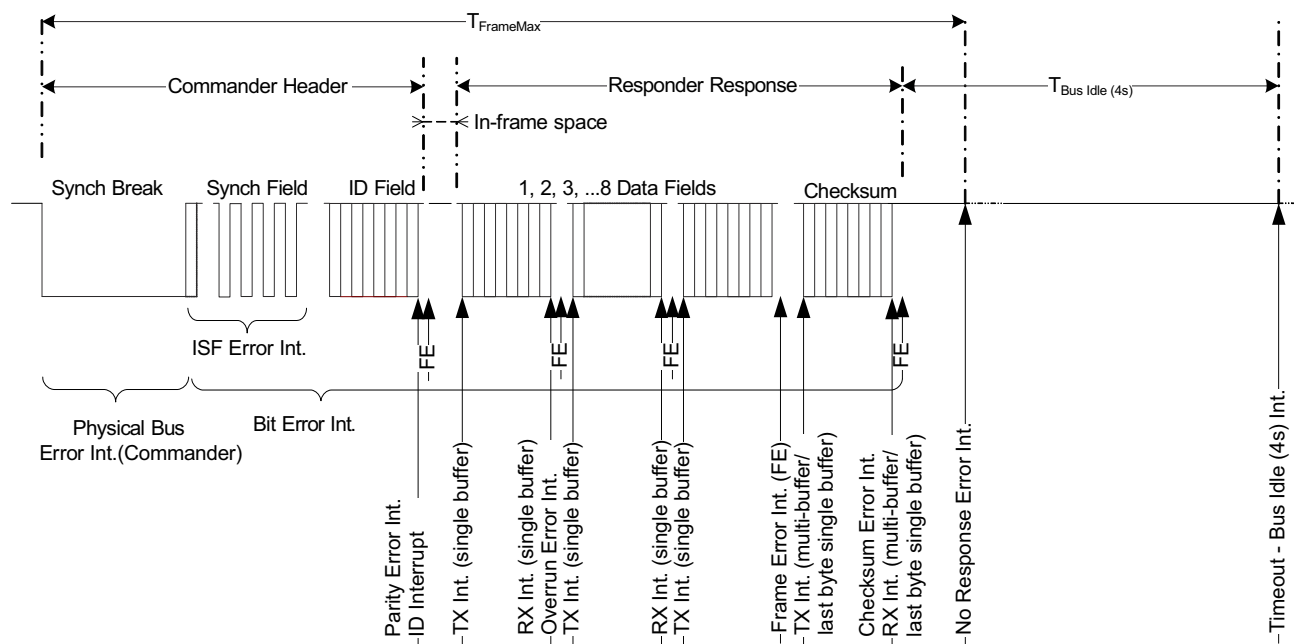

Figure 13-267. LIN Message Frame Showing LIN Interrupt Timing and Sequence

13.4.2.4.3 Servicing LIN Interrupts

When servicing an interrupt, clear the corresponding flag in the flag register (SCIFLR) before clearing the global interrupt flag (LIN_GLB_INT_CLR). The ISR should follow the guidelines below. This will prevent any spurious or duplicate interrupt from occurring.

- Clear the LIN interrupt flag in the SCIFLR register.
- Read the LIN interrupt status register to make sure the flag is cleared.
- Clear the global interrupt flag bit in LIN_GLB_INT_CLR.

Note

The transmit interrupt is generated before the LIN transmitter is ready to accept new data. Inside of the LIN transmit ISR, the software should wait until the buffer is completely empty before loading the next data. This can be done by polling for the Bus Busy Flag (SCIFLR.BUSY) to be 0.

13.4.2.4.4 LIN DMA Interface

The LIN DMA interface uses the SCI DMA interface logic. DMA requests for receive (RXDMA request) and transmit (TXDMA request) are available for the SCI/LIN module. There are two modes for DMA transfers depending on whether multi-buffer mode is enabled or not using the multi-buffer enable control bit (MBUF MODE).

Note

Do not use the DMA to transmit data to multiple peripheral IDs. Writing to the LINID register will initiate a new transmission. The DMA will write to the LINID register before the LIN state machine is ready to accept the new ID. Doing so will cause the LIN to miss this transmission.

13.4.2.4.4.1 LIN Receive DMA Requests

In LIN mode, when the multi-buffer option is enabled, if a received response (up to eight data bytes) is transferred to the receive buffers (RDy), then a DMA request is generated. If the multi-buffer option is disabled, then DMA requests will be generated on a byte-per-byte basis until all the expected response data fields are received. This DMA functionality is enabled and disabled using the SET RX DMA and CLR RX DMA bits, respectively.

13.4.2.4.4.2 LIN Transmit DMA Requests

In LIN mode with the multi-buffer option enabled, after a transmission (up to eight data bytes stored in the transmit buffer(s) TDy in the LINTD0 and LINTD1 registers), a DMA request is generated in order to reload the transmit buffer for the next transmission. If the multi-buffer option is disabled, then DMA requests will be generated on a byte-per-byte basis until all bytes are transferred. This DMA functionality is enabled and disabled using the SET TX DMA and CLR TX DMA bits, respectively.

13.4.2.4.5 LIN Configurations

The following list details the configuration steps that software should perform prior to the transmission or reception of data in LIN mode. As long as the SWnRST bit in the SCIGCR1 register is cleared to 0 the entire time that the LIN is being configured, the order in which the registers are programmed is not important.

- Enable LIN by setting RESET bit.
- Clear SWnRST to 0 before configuring the LIN.
- Select LIN mode by programming LIN MODE bit.
- Select commander or responder mode by programming the CLOCK bit.
- Select the desired frame format (checksum, parity, length control) by programming SCIGCR1.
- Select multi-buffer mode by programming MBUF MODE bit.
- Select the baud rate to be used for communication by programming BRSR.
- Set the maximum baud rate to be used for communication by programming MBRSR.
- Set the CONT bit to make LIN not halt for an emulation breakpoint until its current reception or transmission is complete (this bit is used only in an emulation environment).
- Set LOOP BACK bit to connect the transmitter to the receiver internally if needed (this feature is used to perform a self-test).
- Select the receiver enable RXENA bit, if data is to be received.
- Select the transmit enable TXENA bit, if data is to be transmitted.
- Select the RX ID MASK and the TX ID MASK fields in the LINMASK register.
- Set SWnRST to 1 after the LIN is configured.
- Perform Receive or Transmit data (see [Section 13.4.2.4.1.9](#), [Section 13.4.2.4.5.1](#), and [Section 13.4.2.4.5.2](#)).

13.4.2.4.5.1 Receiving Data

The ID RX FLAG is set after a valid LIN ID is received with RX Match. An ID interrupt is generated, if enabled.

13.4.2.4.5.1.1 Receiving Data in Single-Buffer Mode

Single-buffer mode is selected when the MBUF MODE bit is cleared to 0. In this mode, LIN sets the RXRDY bit when it transfers newly received data from SCIRXSHF to RD0. The SCI clears the RXRDY bit after the new data in RD0 has been read. Also, as data is transferred from SCIRXSHF to RD0, the LIN sets the FE, OE, or PE flags if any of these error conditions were detected in the received data. These error conditions are supported with configurable interrupt capability.

You can receive data by:

1. Polling Receive Ready Flag

2. Receive Interrupt

In polling method, software can poll for the RXRDY bit and read the data from RD0 byte of the LINRD0 register once the RXRDY bit is set high. The CPU is unnecessarily overloaded by selecting the polling method. To avoid this, you can use the interrupt method. To use the interrupt method, the SET RX INT bit is set. If the checksum scheme is enabled by setting the Compare Checksum (CC) bit to 1, the checksum will be compared on the byte that is currently being received, which is expected to be the checksum byte. The CC bit will be cleared once the checksum is received. A CE will immediately be flagged if there is a checksum error.

13.4.2.4.5.1.2 Receiving Data in Multi-Buffer Mode

Multi-buffer mode is selected when the MBUF MODE bit is set to 1. In this mode, LIN sets the RXRDY bit after receiving the programmed number of data in the receive buffer and the checksum field, the complete frame. The error condition detection logic is similar to the single-buffer mode, except that it monitors for the complete frame. Like single-buffer mode, you can use the polling or interrupt method to read the data. The received data has to be read from the LINRD0 and LINRD1 registers, based on the number of bytes. For a LENGTH less than or equal to 4, a read from the LINRD0 register clears the RXRDY flag. For a LENGTH greater than 4, a read from the LINRD1 register clears the RXRDY flag. If the checksum scheme is enabled by setting the Compare Checksum (CC) bit to 1 during the reception of the data, then the byte that is received after the reception of the programmed number of data bytes indicated by the LENGTH field is treated as a checksum byte. The CC bit will be cleared once the checksum is received and compared.

13.4.2.4.5.2 Transmitting Data

The LIN transmitter is enabled if both the TX FUNC bit and the TXENA bit are set to 1. If the TX FUNC bit is not set, the LINTX pin functions as a general-purpose I/O pin rather than as a LIN function pin. Any value written to the TD0 before the TXENA bit is set to 1 is not transmitted. Both of these control bits allow for the LIN transmitter to be held inactive independently of the receiver.

The ID TX flag is set after a valid LIN ID is received with TX Match. An ID interrupt is generated, if enabled.

13.4.2.4.5.2.1 Transmitting Data in Single-Buffer Mode

Single-buffer mode is selected when the MBUF MODE bit is cleared to 0. In this mode, LIN waits for data to be written to TD0, transfers it to SCITXSHF, and transmits the data. The TXRDY and TX EMPTY bits indicate the status of the transmit buffers. That is, when the transmitter is ready for data to be written to TD0, the TXRDY bit is set. Additionally, if both TD0 and SCITXSHF are empty, then the TX EMPTY bit is also set.

You can transmit data by:

1. Polling Transmit Ready Flag
2. Transmit Interrupt

In polling method, software can poll for the TXRDY bit to go high before writing the data to the TD0. The CPU is unnecessarily overloaded by selecting the polling method. To avoid this, you can use the interrupt method. To use the interrupt method, the SET TX INT bit is set. When the LIN has completed transmission of all pending frames, the SCITXSHF register and the TD0 are empty, the TXRDY bit is set, and an interrupt request is generated, if enabled. Because all data has been transmitted, the interrupt request should be halted. This can either be done by disabling the transmit interrupt (CLR TX INT) or by disabling the transmitter (clear TXENA bit). If the checksum scheme is enabled by setting the Send Checksum (SC) bit to 1, the checksum byte will be sent after the current byte transmission. The SC bit will be cleared after the checksum byte has been transmitted.

Note

The TXRDY flag cannot be cleared by reading the corresponding interrupt offset in the SCIINTVECT0 or SCIINTVECT1 register.

13.4.2.4.5.2.2 Transmitting Data in Multi-Buffer Mode

Multi-buffer mode is selected when the MBUF MODE bit is set to 1. Like single-buffer mode, you can use the polling or interrupt method to write the data to be transmitted. The transmitted data has to be written to the LINTD0 and LINTD1 registers, based on the number of bytes. LIN waits for data to be written to Byte 0 (TD0) of the LINTD0 register and transfers the programmed number of bytes to SCITXSHF to transmit one by one automatically. If the checksum scheme is enabled by setting the Send Checksum (SC) bit to 1, the checksum will be sent after transmission of the last byte of the programmed number of data bytes, indicated by the LENGTH field. The SC bit will be cleared after the checksum byte has been transmitted.

13.4.2.5 Low-Power Mode

The SCI/LIN module can be put in either local or global low-power mode. Global low-power mode is asserted by the system and is not controlled by the SCI/LIN module. During global low-power mode, all clocks to the SCI/LIN are turned off so the module is completely inactive. If global low-power mode is requested while the receiver is receiving data, then the SCI/LIN completes the current reception and then enters the low-power mode, that is, module enters low-power mode only when Busy bit (SCIFLR.3) is cleared.

The LIN module may enter low-power mode either when there was no activity on the LINRX pin for more than 4s (this can be either a constant recessive or dominant level) or when a Sleep Command frame was received. Once the Timeout flag (SCIFLR.4) was set or once a Sleep Command was received, the POWERDOWN bit (SCIGCR2.0) must be set by the application software to make the module enter local low-power mode. A wakeup signal will terminate the sleep mode of the LIN bus.

Note

Enabling Local Low-Power Mode During Receive and Transmit

If the wakeup interrupt is enabled and low-power mode is requested while the receiver is receiving data, then the SCI/LIN immediately generates a wake-up interrupt to clear the powerdown bit. Thus, the SCI/LIN is prevented from entering low-power mode and completes the current reception. Otherwise, if the wakeup interrupt is disabled, the SCI/LIN completes the current reception and then enters the low-power mode.

13.4.2.5.1 Entering Sleep Mode

In LIN protocol, a sleep command is used to broadcast the sleep mode to all nodes. The sleep command consists of a diagnostic commander request frame with identifier 0x3C (60), with the first data field as 0x00. There should be no activity in the bus once all nodes receive the sleep command: the bus is in sleep mode.

Local low-power mode is asserted by setting the POWERDOWN bit; setting this bit stops the clocks to the SCI/LIN internal logic and registers. Clearing the POWERDOWN bit causes SCI/LIN to exit from local low-power mode. All the registers are accessible during local power-down mode. If a register is accessed in low-power mode, this access results in enabling the clock to the module for that particular access alone.

13.4.2.5.2 Wakeup

The wakeup interrupt is used to allow the SCI/LIN module to automatically exit a low-power mode. A SCI/LIN wakeup is triggered when a low level is detected on the receive RX pin, and this clears the POWERDOWN bit.

Note

If the wakeup interrupt is disabled, then the SCI/LIN enters low-power mode whenever it is requested to do so, but a low level on the receive RX pin does NOT cause the SCI/LIN to exit low-power mode.

In LIN mode, any node can terminate sleep mode by sending a wakeup signal, see [Figure 13-268](#). A responder node that detects the bus in sleep mode, and with a wakeup request pending, will send a wakeup signal. The wakeup signal is a dominant value on the LIN bus for T_{WUSIG} ; this is at least $5 T_{bits}$ for the LIN bus baud rates. The wakeup signal is generated by sending a 0xF0 byte containing 5 dominant T_{bits} and 5 recessive T_{bits} .

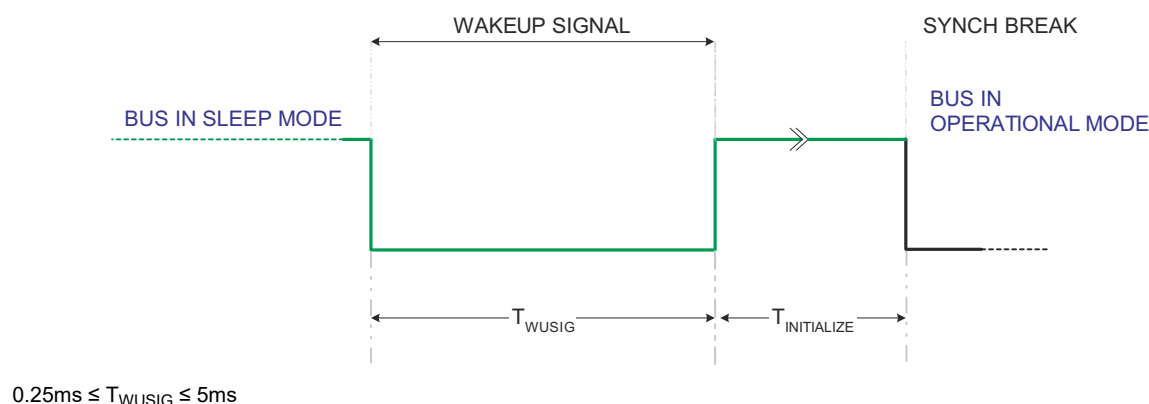

Figure 13-268. Wakeup Signal Generation

Assuming a perfect bus with no noise or loading effects, a write of 0xF0 to TD0 will load the transmitter to meet the wakeup signal timing requirement for T_{WUSIG} . Then, setting the GENWU bit will transmit the preloaded value in TD0 for a wakeup signal transmission.

Note

The GENWU bit can be set/reset only when SWnRST is set to '1' and the node is in power down mode. The bit will be cleared on a valid synch break detection. A commander sending a wakeup request, will exit power down mode upon reception of the wakeup pulse. The bit will be cleared on a SWnRST. This can be used to stop a commander from sending further wakeup requests.

The TI TPIC1021 LIN transceiver, upon receiving a wakeup signal, will translate it to the microcontroller for wakeup with a dominant level on the RX pin, or a signal to the voltage regulator. While the POWERDOWN bit is set, if the LIN module detects a recessive-to-dominant edge (falling edge) on the RX pin, it will generate a wakeup interrupt if enabled in the SCISSETINT register.

According to LIN protocol 2.0, the TI TPIC1021 LIN transceiver detecting a dominant level on the bus longer than 150 ms will detect it as a wakeup request. The LIN responder is ready to listen to the bus in less than 100 ms ($T_{INITIALIZE} < 100\text{ms}$) after a dominant-to-recessive edge (end-of-wakeup signal).

13.4.2.5.3 Wakeup Timeouts

The LIN protocol defines the following timeouts for a wakeup sequence. After a wakeup signal has been sent to the bus, all nodes wait for the commander to send a header. If no synch field is detected before 150 ms (3,000 cycles at 20 kHz) after a wakeup signal is transmitted, a new wakeup is sent by the same node that requested the first wakeup. This sequence is not repeated more than two times. After three attempts to wake up the LIN bus, wakeup signal generation is suspended for a 1.5 s (30,000 cycles at 20 kHz) period after three breaks.

Note

To achieve compatibility to LIN1.3 timeout conditions, the MBRS register must be set to assure that the LIN 2.0 (real-time-based) timings meet the LIN 1.3 bit time base. A node triggering the wakeup should set the MBRS register accordingly to meet the targeted time as $128 \text{ Tbits} \times \text{programmed prescaler}$.

The LIN handles the wakeup expiration times defined by the LIN protocol with a hardware implementation.

13.4.2.6 Emulation Mode

In emulation mode, the CONT bit determines how the SCI/LIN operates when the program is suspended. The SCI/LIN counters are affected by this bit during debug mode. when set, the counters are not stopped and when cleared, the counters are stopped debug mode.

Any reads in emulation mode to a SCI/LIN register will not have any effect on the flags in the SCIFLR register.

Note

When emulation mode is entered during the Frame transmission or reception of the frame and CONT bit is not set, Communication is not expected to be successful. The suggested usage is to set CONT bit during emulation mode for successful communication.

13.5 Timer Modules

This section describes the timer modules in the device.

13.5.1 Real Time Interrupts/Windowed Watchdog Timer (RTI/WWDT)

This section describes the Real Time Interrupt/Windowed Watchdog Timer (RTI/WWDT) module implemented in the device.

13.5.1.1 RTI/WWDT Overview	1439
13.5.1.2 RTI Integration	1443
13.5.1.3 WWDT Integration	1450
13.5.1.4 RTI Functional Description	1455

13.5.1.1 RTI/WWDT Overview

The Real Time Interrupt module of the RTI/WWDT module provides general timer functionality for operating systems and for benchmarking code. The module incorporates several counters, which define the timebases needed for operating system-based scheduling requirements.

This module is specifically designed to fulfill the requirements for OSEK (“Offene Systeme und deren Schnittstellen für die Elektronik im Kraftfahrzeug”; “Open Systems and the Corresponding Interfaces for Automotive Electronics”) as well as OSEK/Time compliant operating systems.

The timers also provide the ability to benchmark certain areas of code by reading the counter contents at the beginning and the end of the desired code range and calculating the difference between the values.

There are eight RTI/WWDT modules in the device. [Table 13-279](#) shows the RTI allocation across device domains.

Note

Four instances are configured in RTI-only mode to function as general purpose timers. Another four instances are configured in WWDT-only mode to function as watchdog timers.

Table 13-279. RTI Device Instance Table

Instance	Device
RTI0	✓
RTI1	✓
RTI2	✓

Table 13-279. RTI Device Instance Table (continued)

Instance	Device
RTI3	✓

This diagram shows the module overview.

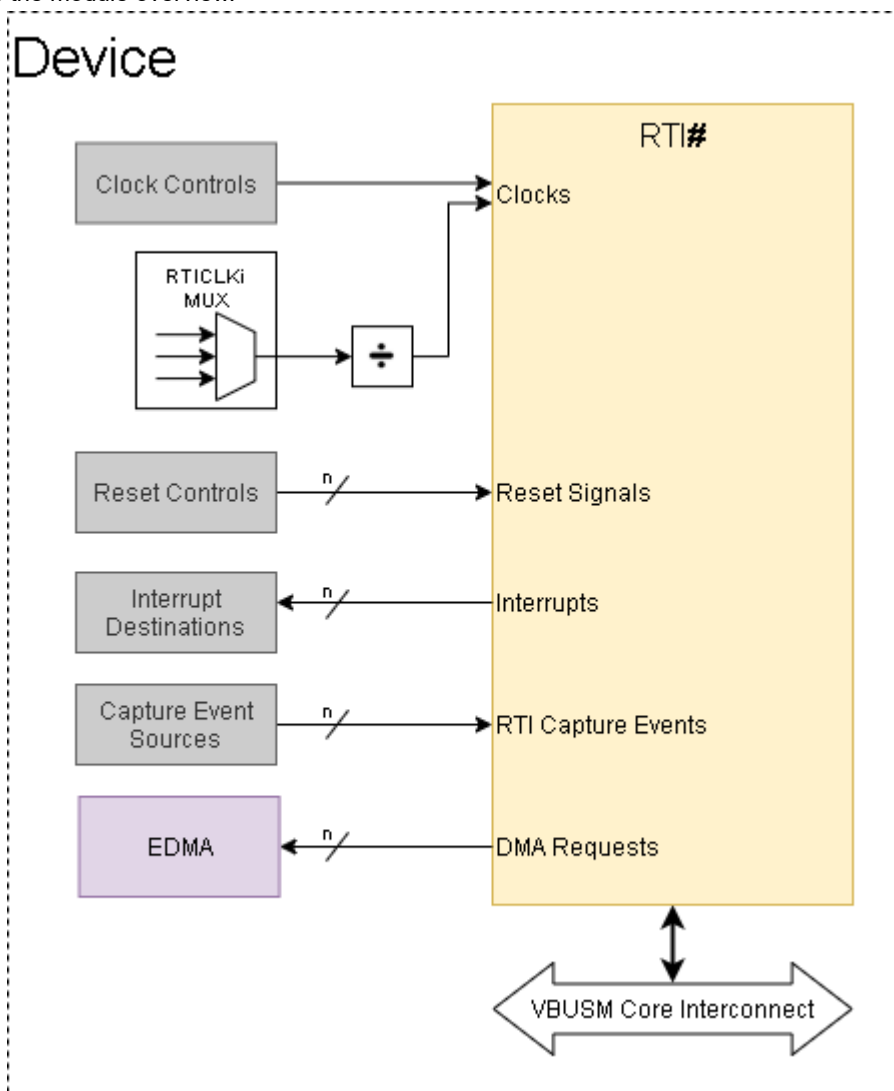

Figure 13-269. RTI Overview

= 0, 1, 2, 3
 # = 0, 1, 2, 3

Table 13-280. WWDT Device Instance Table

Instance	Device
WWDT1	✓
WWDT2	✓
WWDT3	✓
WWDT0	✓

The WWDT instances are intended to function as a digital windowed watchdog for the CPU core that they are associated with:

- WWDT0 is dedicated to the first R5F CPU core (R5FSS0_CORE0)

- WWDT1 is dedicated to the second R5F CPU core (R5FSS0_CORE1)
- WWDT2 is dedicated to the third R5F CPU core (R5FSS1_CORE0)
- WWDT3 is dedicated to the fourth R5F CPU core (R5FSS1_CORE1)

All WWDT instances that are provisioned for a particular CPU core should not be used by any other CPU cores.

This diagram shows the module overview.

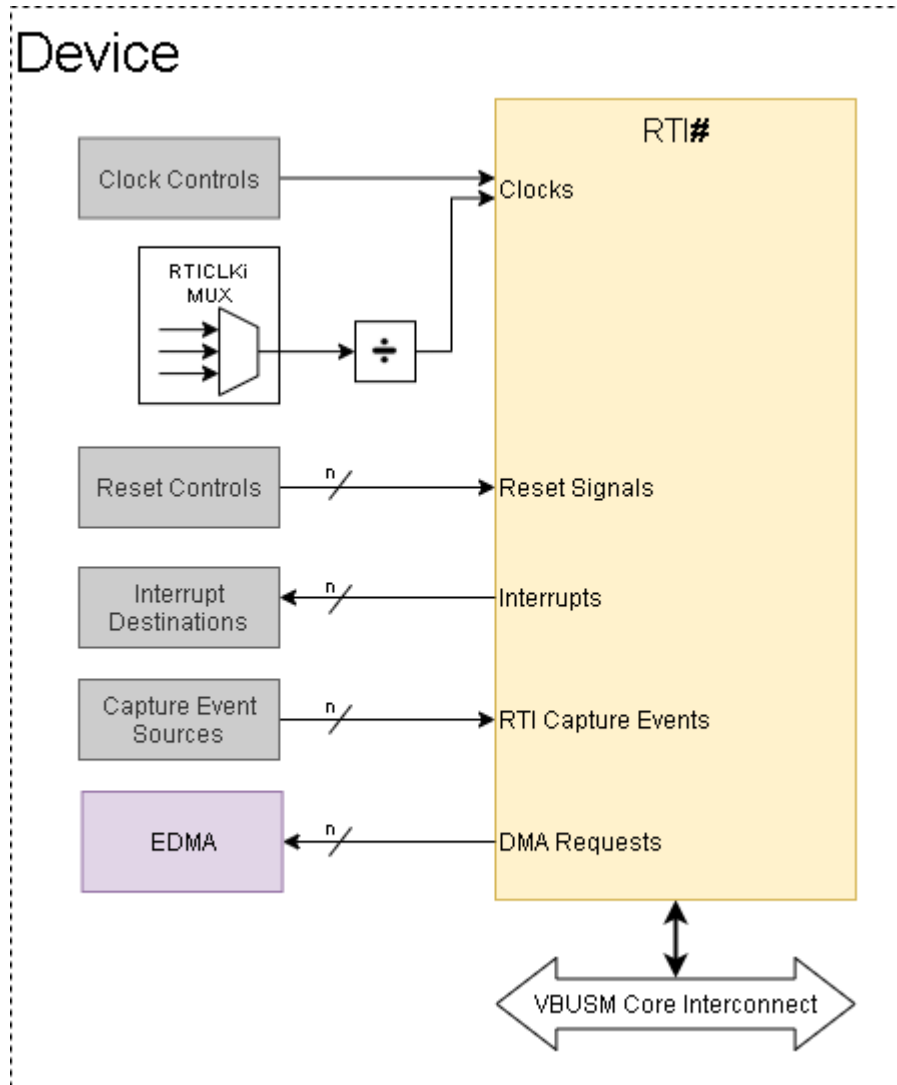

Figure 13-270. WWDT Overview

13.5.1.1.1 RTI Features

The RTI modules include the following main features:

- Windowed Watchdog Timer (WWDT) feature.
- Two independent 64 bit counter blocks (counter block0 or counter block1). Each block consists of
 - One 32 bit up counter
 - One 32 bit free running counter
 - Two capture registers for capturing the prescale and free running counter on a special event.
- Free running counter 0 can be incremented by the internal prescale counter.
- Four configurable compare registers for generating operating system ticks . Each event can be driven by either counter block0 or counter block1.
- Fast enabling/disabling of events.

- RTI clock input derived from any of the available clock sources, selectable in the System Module
- Optional capability to drive a pulse-width modulated signal out on an interrupt line.

13.5.1.2 RTI Integration

This section describes module integration in the device, including information about clocks, resets, and hardware requests.

13.5.1.2.1 RTI Integration

There are 4x RTI modules integrated in the device. The diagram and tables below show the device integration details.

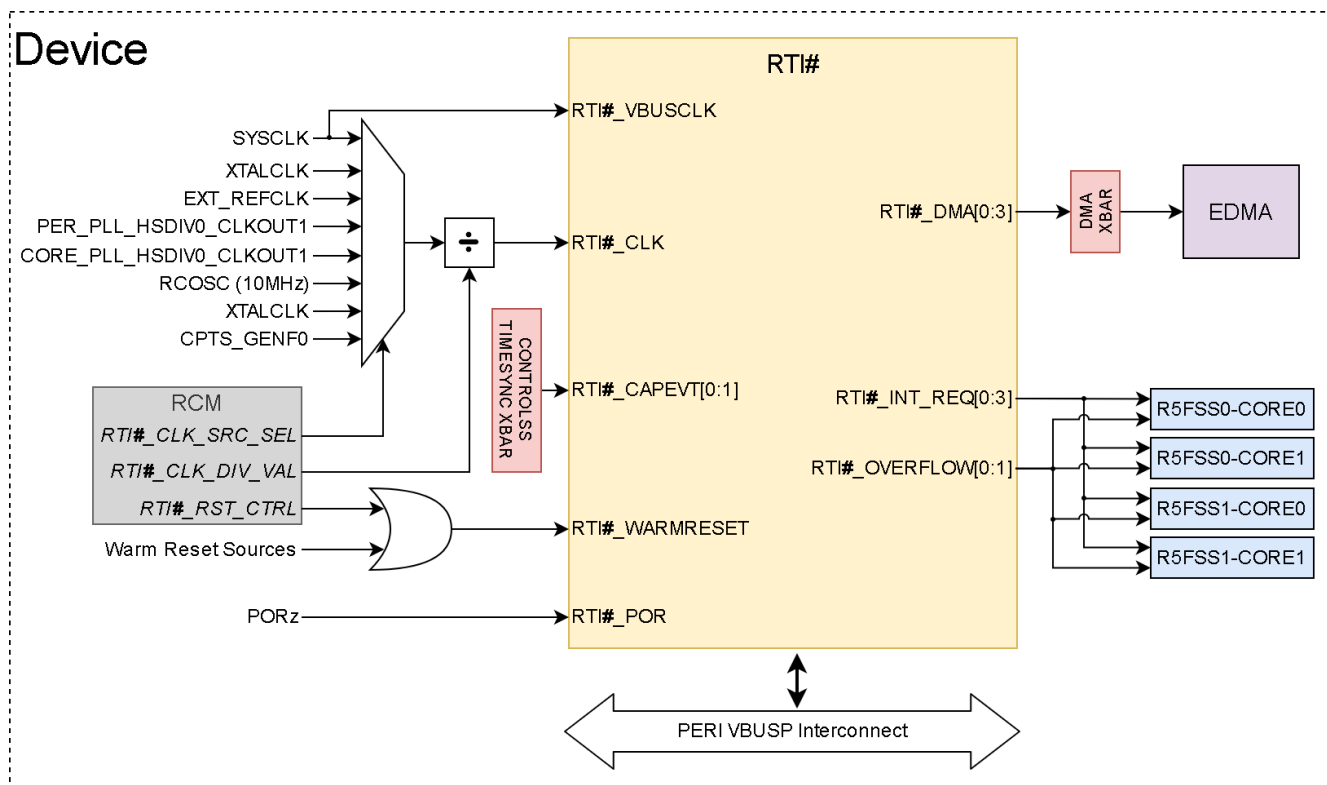

Figure 13-271. RTI Integration

The tables below summarize the integration of RTI# (where # = 0, 1, 2, 3) in the device.

Each RTI# instance is supplied by dedicated RTICK# mux.

Table 13-281. RTI Device Integration

This table describes the module device integration details.

Module Instance	Device Allocation	SoC Interconnect
RTI0	✓	VBUSP CORE Interconnect
RTI1	✓	VBUSP CORE Interconnect
RTI2	✓	VBUSP CORE Interconnect
RTI3	✓	VBUSP CORE Interconnect

Table 13-282. RTI Clocks

This table describes the module clocking signals.

Module Instance	Module Clock Input	Source Clock Signal	Source	Default Freq	Description
RTI0	RTI0_ICLK (VBUSP_CLK)	SYS_CLK	PLL_CORE_CLK: HSDIV0_CLKOUT0	200 MHz	RTI0 VBUSP Interface Clock
	RTI0_FCLK (RTI_CLK)	XTALCLK	External XTAL	25 MHz	RTI0 Functional Clock
		EXT_REFCLK	External Reference Clock (EXT_REFCLK)	100 MHz	
		SYS_CLK	PLL_CORE_CLK: HSDIV0_CLKOUT0	200 MHz	
		DPLL_PER_HSDIV0_CLK OUT1	PLL_PER_CLK: HSDIV0_CLKOUT1	192 MHz	
		DPLL_CORE_HSDIV0_CL KOUT1	PLL_CORE_CLK: HSDIV0_CLKOUT1	500 MHz	
		RCCLK10M	Internal 10 MHz RC Oscillator (RCCLK10M)	10 MHz	
		XTALCLK	External XTAL	25 MHz	
		CTPS_GENF0	CPSW3G CPTS GENF0 Clock	50 MHz	
RTI1	RTI1_ICLK (VBUSP_CLK)	SYS_CLK	PLL_CORE_CLK: HSDIV0_CLKOUT0	200 MHz	RTI1 VBUSP Interface Clock
	RTI1_FCLK (RTI_CLK)	XTALCLK	External XTAL	25 MHz	RTI1 Functional Clock
		EXT_REFCLK	External Reference Clock (EXT_REFCLK)	100 MHz	
		SYS_CLK	PLL_CORE_CLK: HSDIV0_CLKOUT0	200 MHz	
		DPLL_PER_HSDIV0_CLK OUT1	PLL_PER_CLK: HSDIV0_CLKOUT1	192 MHz	
		DPLL_CORE_HSDIV0_CL KOUT1	PLL_CORE_CLK: HSDIV0_CLKOUT1	500 MHz	
		RCCLK10M	Internal 10 MHz RC Oscillator (RCCLK10M)	10 MHz	
		XTALCLK	External XTAL	25 MHz	
		CTPS_GENF0	CPSW3G CPTS GENF0 Clock	50 MHz	

Table 13-282. RTI Clocks (continued)

This table describes the module clocking signals.

Module Instance	Module Clock Input	Source Clock Signal	Source	Default Freq	Description
RTI2	RTI2_ICLK (VBUSP_CLK)	SYS_CLK	PLL_CORE_CLK: HSDIV0_CLKOUT0	200 MHz	RTI2 VBUSP Interface Clock
	RTI2_FCLK (RTI_CLK)	XTALCLK	External XTAL	25 MHz	RTI2 Functional Clock
		EXT_REFCLK	External Reference Clock (EXT_REFCLK)	100 MHz	
		SYS_CLK	PLL_CORE_CLK: HSDIV0_CLKOUT0	200 MHz	
		DPLL_PER_HSDIV0_CLK OUT1	PLL_PER_CLK: HSDIV0_CLKOUT1	192 MHz	
		DPLL_CORE_HSDIV0_CLK KOUT1	PLL_CORE_CLK: HSDIV0_CLKOUT1	500 MHz	
		RCCLK10M	Internal 10 MHz RC Oscillator (RCCLK10M)	10 MHz	
		XTALCLK	External XTAL	25 MHz	
CTPS_GENF0	CPSW3G CPTS GENF0 Clock	50 MHz			
RTI3	RTI3_ICLK (VBUSP_CLK)	SYS_CLK	PLL_CORE_CLK: HSDIV0_CLKOUT0	200 MHz	RTI3 VBUSP Interface Clock
	RTI3_FCLK (RTI_CLK)	XTALCLK	External XTAL	25 MHz	RTI3 Functional Clock
		EXT_REFCLK	External Reference Clock (EXT_REFCLK)	100 MHz	
		SYS_CLK	PLL_CORE_CLK: HSDIV0_CLKOUT0	200 MHz	
		DPLL_PER_HSDIV0_CLK OUT1	PLL_PER_CLK: HSDIV0_CLKOUT1	192 MHz	
		DPLL_CORE_HSDIV0_CLK KOUT1	PLL_CORE_CLK: HSDIV0_CLKOUT1	500 MHz	
		RCCLK10M	Internal 10 MHz RC Oscillator (RCCLK10M)	10 MHz	
		XTALCLK	External XTAL	25 MHz	
CTPS_GENF0	CPSW3G CPTS GENF0 Clock	50 MHz			

Table 13-283. RTI Resets

This table describes the module reset signals.

Module Instance	Module Reset Input	Source Reset Signal	Source	Description
RTI0	RTI0_RST	Warm Reset (MOD_G_RST)	RCM + Warm Reset Sources	RTI0 Asynchronous Reset
	RTI0_POR_RST	POR Reset (MOD_POR_RST)	Device Power-On Reset	RTI0 Power-On Reset

Table 13-283. RTI Resets (continued)

This table describes the module reset signals.

Module Instance	Module Reset Input	Source Reset Signal	Source	Description
RTI1	RTI1_RST	Warm Reset (MOD_G_RST)	RCM + Warm Reset Sources	RTI1 Asynchronous Reset
	RTI1_POR_RST	POR Reset (MOD_POR_RST)	Device Power-On Reset	RTI1 Power-On Reset
RTI2	RTI2_RST	Warm Reset (MOD_G_RST)	RCM + Warm Reset Sources	RTI2 Asynchronous Reset
	RTI2_POR_RST	POR Reset (MOD_POR_RST)	Device Power-On Reset	RTI2 Power-On Reset
RTI3	RTI3_RST	Warm Reset (MOD_G_RST)	RCM + Warm Reset Sources	RTI3 Asynchronous Reset
	RTI3_POR_RST	POR Reset (MOD_POR_RST)	Device Power-On Reset	RTI3 Power-On Reset

Table 13-284. RTI Interrupt Requests

This table describes the module interrupt requests.

Module Instance	Module Interrupt Signal	Destination Interrupt Input	Destination	Type	Description
RTI0	RTI0_INT_REQ_0	RTI0_INT_REQ_0	ALL R5FSS Cores	Level	RTI0 Status Event Interrupt
	RTI0_INT_REQ_1	RTI0_INT_REQ_1			
	RTI0_INT_REQ_2	RTI0_INT_REQ_2			
	RTI0_INT_REQ_3	RTI0_INT_REQ_3			
	RTI0_OVL_REQ_0	RTI0_OVERFLOW_LEVEL_0			RTI0 Counter Overflow Event Interrupt
	RTI0_OVL_REQ_1	RTI0_OVERFLOW_LEVEL_1			
RTI1	RTI1_INT_REQ_0	RTI1_INT_REQ_0	ALL R5FSS Cores	Level	RTI1 Status Event Interrupt
	RTI1_INT_REQ_1	RTI1_INT_REQ_1			
	RTI1_INT_REQ_2	RTI1_INT_REQ_2			
	RTI1_INT_REQ_3	RTI1_INT_REQ_3			
	RTI1_OVL_REQ_0	RTI1_OVERFLOW_LEVEL_0			RTI1 Counter Overflow Event Interrupt
	RTI1_OVL_REQ_1	RTI1_OVERFLOW_LEVEL_1			
RTI2	RTI2_INT_REQ_0	RTI2_INT_REQ_0	ALL R5FSS Cores	Level	RTI2 Status Event Interrupt
	RTI2_INT_REQ_1	RTI2_INT_REQ_1			
	RTI2_INT_REQ_2	RTI2_INT_REQ_2			
	RTI2_INT_REQ_3	RTI2_INT_REQ_3			
	RTI2_OVL_REQ_0	RTI2_OVERFLOW_LEVEL_0			RTI2 Counter Overflow Event Interrupt
	RTI2_OVL_REQ_1	RTI2_OVERFLOW_LEVEL_1			
RTI3	RTI3_INT_REQ_0	RTI3_INT_REQ_0	ALL R5FSS Cores	Level	RTI3 Status Event Interrupt
	RTI3_INT_REQ_1	RTI3_INT_REQ_1			
	RTI3_INT_REQ_2	RTI3_INT_REQ_2			
	RTI3_INT_REQ_3	RTI3_INT_REQ_3			
	RTI3_OVL_REQ_0	RTI3_OVERFLOW_LEVEL_0			RTI3 Counter Overflow Event Interrupt
	RTI3_OVL_REQ_1	RTI3_OVERFLOW_LEVEL_1			

Table 13-285. RTI DMA Requests

This table describes the module DMA requests.

Module Instance	Module DMA Event	Destination DMA Event Input	Destination	Type	Description				
RTI0	RTI0_DMA_0	RTI0_DMA_REQ_0	EDMA Crossbar (EDMA_XBAR)	Level	RTI0 DMA Request				
	RTI0_DMA_1	RTI0_DMA_REQ_1							
	RTI0_DMA_2	RTI0_DMA_REQ_2							
	RTI0_DMA_3	RTI0_DMA_REQ_3							
RTI1	RTI1_DMA_0	RTI1_DMA_REQ_0			EDMA Crossbar (EDMA_XBAR)	Level	RTI1 DMA Request		
	RTI1_DMA_1	RTI1_DMA_REQ_1							
	RTI1_DMA_2	RTI1_DMA_REQ_2							
	RTI1_DMA_3	RTI1_DMA_REQ_3							
RTI2	RTI2_DMA_0	RTI2_DMA_REQ_0					EDMA Crossbar (EDMA_XBAR)	Level	RTI2 DMA Request
	RTI2_DMA_1	RTI2_DMA_REQ_1							
	RTI2_DMA_2	RTI2_DMA_REQ_2							
	RTI2_DMA_3	RTI2_DMA_REQ_3							
RTI3	RTI3_DMA_0	RTI3_DMA_REQ_0	EDMA Crossbar (EDMA_XBAR)	Level					RTI3 DMA Request
	RTI3_DMA_1	RTI3_DMA_REQ_1							
	RTI3_DMA_2	RTI3_DMA_REQ_2							
	RTI3_DMA_3	RTI3_DMA_REQ_3							

Table 13-286. RTI Capture Events

This table describes the module capture events.

Module Instance	Module Capture Event Input	Capture Event Source Signal	Source	Type	Description						
RTI0	RTI0_CAPEVT_0	SoC_TIMESYNC_XBAROUT_2	SoC Time Sync Crossbar (TIMESYNC_XBAR)	Level	RTI0 Counter Capture Input Event						
	RTI0_CAPEVT_1	SoC_TIMESYNC_XBAROUT_3									
RTI1	RTI1_CAPEVT_0	SoC_TIMESYNC_XBAROUT_4			SoC Time Sync Crossbar (TIMESYNC_XBAR)	Level	RTI1 Counter Capture Input Event				
	RTI1_CAPEVT_1	SoC_TIMESYNC_XBAROUT_5									
RTI2	RTI2_CAPEVT_0	SoC_TIMESYNC_XBAROUT_6					SoC Time Sync Crossbar (TIMESYNC_XBAR)	Level	RTI2 Counter Capture Input Event		
	RTI2_CAPEVT_1	SoC_TIMESYNC_XBAROUT_7									
RTI3	RTI3_CAPEVT_0	SoC_TIMESYNC_XBAROUT_8							SoC Time Sync Crossbar (TIMESYNC_XBAR)	Level	RTI3 Counter Capture Input Event
	RTI3_CAPEVT_1	SoC_TIMESYNC_XBAROUT_9									

Note

For more information on the interconnects, see the *System Interconnect* chapter.

For more information on the power, reset and clock management, see the corresponding sections within the *Device Configuration* chapter.

For more information on the device interrupt controllers, see the *Interrupt Controllers* chapter.

13.5.1.3 WWDT Integration

This section describes the module integration in the device, including information about clocks, resets, and hardware requests.

13.5.1.3.1 WWDT Integration

There are 4x WWDT modules integrated in the device. The diagram and tables below show the device integration details.

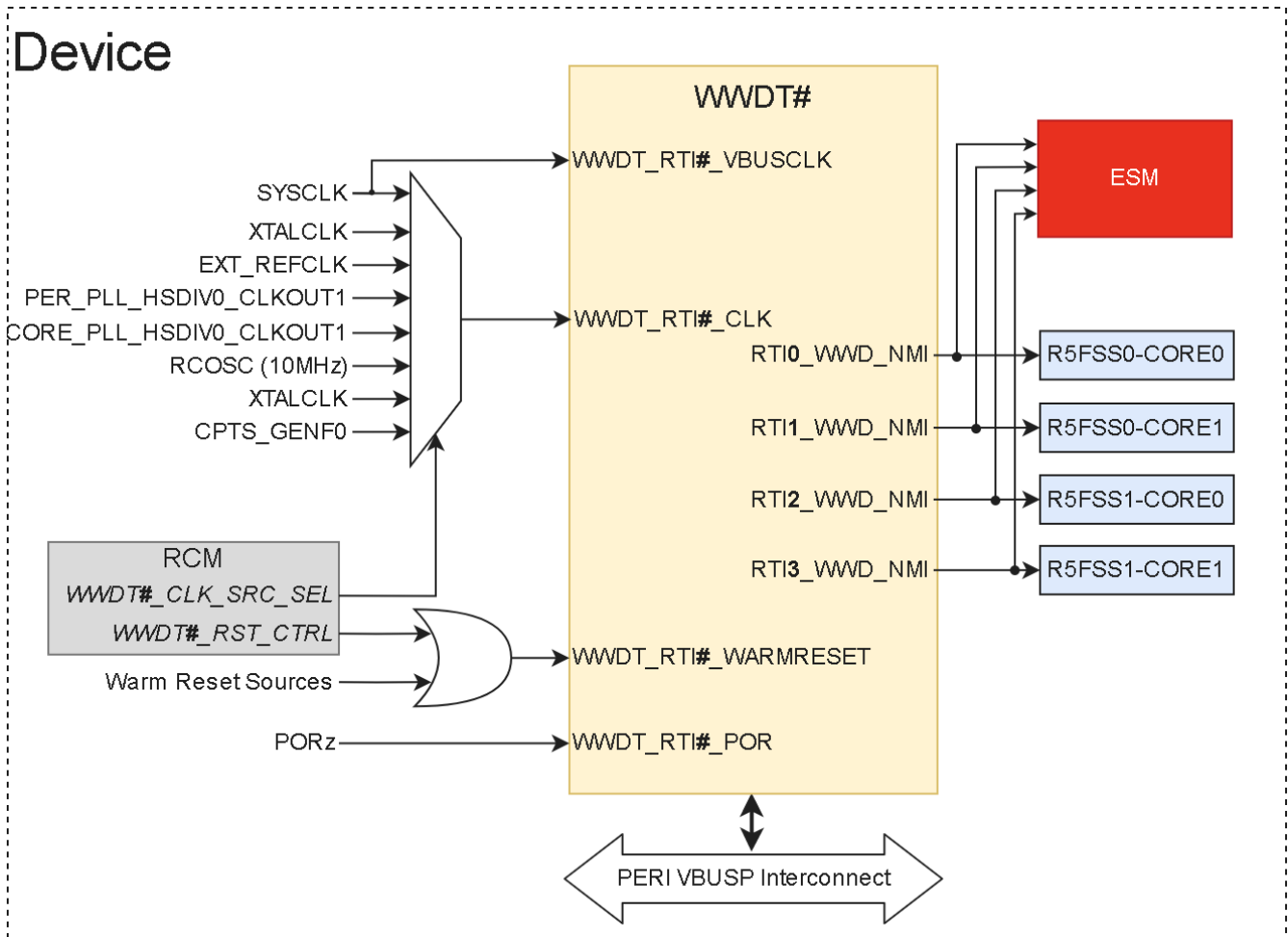

ADVANCE INFORMATION

Figure 13-272. WWDT Integration

The tables below summarize the integration of WWDT# (where # = 0, 1, 2, 3) in the device.

Each WWDT# instance is supplied by dedicated WWDTCLK# mux.

Table 13-287. WWDT Device Integration

This table describes the module device integration details.

Module Instance	Device Allocation	SoC Interconnect
WWDT0	✓	VBUSP CORE Interconnect
WWDT1	✓	VBUSP CORE Interconnect
WWDT2	✓	VBUSP CORE Interconnect
WWDT3	✓	VBUSP CORE Interconnect

Table 13-288. WWDT Clocks

This table describes the module clocking signals.

Module Instance	Module Clock Input	Source Clock Signal	Source	Default Freq	Description
WWDT0	WWDT0_ICLK (VBUSP_CLK)	SYS_CLK	PLL_CORE_CLK: HSDIV0_CLKOUT0	200 MHz	WWDT0 VBUSP Interface Clock
	WWDT0_FCLK (WWDT_CLK)	XTALCLK	External Crystal (XTAL)	25 MHz	WWDT0 Functional Clock
		EXT_REFCLK	External Reference Clock (EXT_REFCLK)	100 MHz	
		SYS_CLK	PLL_CORE_CLK: HSDIV0_CLKOUT0	200 MHz	
		DPLL_PER_HSDIV0_CLK OUT1	PLL_PER_CLK: HSDIV0_CLKOUT1	192 MHz	
		DPLL_CORE_HSDIV0_CLK OUT1	PLL_CORE_CLK: HSDIV0_CLKOUT1	500 MHz	
		RCCLK10M	Internal 10 MHz RC Oscillator (RCCLK10M)	10 MHz	
		XTALCLK	External Crystal (XTAL)	25 MHz	
		CTPS_GENF0	CPSW3G CPTS GENF0 Clock	50 MHz	
WWDT1	WWDT1_ICLK (VBUSP_CLK)	SYS_CLK	PLL_CORE_CLK: HSDIV0_CLKOUT0	200 MHz	WWDT1 VBUSP Interface Clock
	WWDT1_FCLK (WWDT_CLK)	XTALCLK	External Crystal (XTAL)	25 MHz	WWDT1 Functional Clock
		EXT_REFCLK	External Reference Clock (EXT_REFCLK)	100 MHz	
		SYS_CLK	PLL_CORE_CLK: HSDIV0_CLKOUT0	200 MHz	
		DPLL_PER_HSDIV0_CLK OUT1	PLL_PER_CLK: HSDIV0_CLKOUT1	192 MHz	
		DPLL_CORE_HSDIV0_CLK OUT1	PLL_CORE_CLK: HSDIV0_CLKOUT1	500 MHz	
		RCCLK10M	Internal 10 MHz RC Oscillator (RCCLK10M)	10 MHz	
		XTALCLK	External Crystal (XTAL)	25 MHz	
		CTPS_GENF0	CPSW3G CPTS GENF0 Clock	50 MHz	

Table 13-288. WWDT Clocks (continued)

This table describes the module clocking signals.

Module Instance	Module Clock Input	Source Clock Signal	Source	Default Freq	Description
WWDT2	WWDT2_ICLK (VBUSP_CLK)	SYS_CLK	PLL_CORE_CLK: HSDIV0_CLKOUT0	200 MHz	WWDT2 VBUSP Interface Clock
	WWDT2_FCLK (WWDT_CLK)	XTALCLK	External Crystal (XTAL)	25 MHz	WWDT2 Functional Clock
		EXT_REFCLK	External Reference Clock (EXT_REFCLK)	100 MHz	
		SYS_CLK	PLL_CORE_CLK: HSDIV0_CLKOUT0	200 MHz	
		DPLL_PER_HSDIV0_CLK OUT1	PLL_PER_CLK: HSDIV0_CLKOUT1	192 MHz	
		DPLL_CORE_HSDIV0_CLK KOUT1	PLL_CORE_CLK: HSDIV0_CLKOUT1	500 MHz	
		RCCLK10M	Internal 10 MHz RC Oscillator (RCCLK10M)	10 MHz	
		XTALCLK	External Crystal (XTAL)	25 MHz	
CTPS_GENF0	CPSW3G CPTS GENF0 Clock	50 MHz			
WWDT3	WWDT3_ICLK (VBUSP_CLK)	SYS_CLK	PLL_CORE_CLK: HSDIV0_CLKOUT0	200 MHz	WWDT3 VBUSP Interface Clock
	WWDT3_FCLK (WWDT_CLK)	XTALCLK	External Crystal (XTAL)	25 MHz	WWDT3 Functional Clock
		EXT_REFCLK	External Reference Clock (EXT_REFCLK)	100 MHz	
		SYS_CLK	PLL_CORE_CLK: HSDIV0_CLKOUT0	200 MHz	
		DPLL_PER_HSDIV0_CLK OUT1	PLL_PER_CLK: HSDIV0_CLKOUT1	192 MHz	
		DPLL_CORE_HSDIV0_CLK KOUT1	PLL_CORE_CLK: HSDIV0_CLKOUT1	500 MHz	
		RCCLK10M	Internal 10 MHz RC Oscillator (RCCLK10M)	10 MHz	
		XTALCLK	External Crystal (XTAL)	25 MHz	
CTPS_GENF0	CPSW3G CPTS GENF0 Clock	50 MHz			

Table 13-289. WWDT Resets

This table describes the module reset signals.

Module Instance	Module Reset Input	Source Reset Signal	Source	Description
WWDT0	WWDT0_RST	Warm Reset (MOD_G_RST)	RCM Reset Control Register + Warm Reset Sources	WWDT0 Asynchronous Reset
	WWDT0_POR_RST	POR Reset (MOD_POR_RST)	Device Power-On Reset	WWDT0 Power-On Reset

Table 13-289. WWDT Resets (continued)

This table describes the module reset signals.

Module Instance	Module Reset Input	Source Reset Signal	Source	Description
WWDT1	WWDT1_RST	Warm Reset (MOD_G_RST)	RCM Reset Control Register + Warm Reset Sources	WWDT1 Asynchronous Reset
	WWDT1_POR_RST	POR Reset (MOD_POR_RST)	Device Power-On Reset	WWDT1 Power-On Reset
WWDT2	WWDT2_RST	Warm Reset (MOD_G_RST)	RCM Reset Control Register + Warm Reset Sources	WWDT2 Asynchronous Reset
	WWDT2_POR_RST	POR Reset (MOD_POR_RST)	Device Power-On Reset	WWDT2 Power-On Reset
WWDT3	WWDT3_RST	Warm Reset (MOD_G_RST)	RCM Reset Control Register + Warm Reset Sources	WWDT3 Asynchronous Reset
	WWDT3_POR_RST	POR Reset (MOD_POR_RST)	Device Power-On Reset	WWDT3 Power-On Reset

Table 13-290. WWDT Interrupt Requests

This table describes the module interrupt requests.

Module Instance	Module Interrupt Signal	Destination Interrupt Input	Destination	Type	Description
WWDT0	WWDT0_NMI_REQ	ESM0_PLS_IN_0	ESM0	Pulse	WWDT0 Window Watchdog Violation Non-Maskable Interrupt (NMI) Event
		R5FSS0_0_VIM_128	R5FSS0_CORE0		
WWDT1	WWDT1_NMI_REQ	ESM0_PLS_IN_1	ESM0	Pulse	WWDT1 Non-Maskable Interrupt (NMI) Event
		R5FSS0_1_VIM_128	R5FSS0_CORE1		
WWDT2	WWDT2_NMI_REQ	ESM0_PLS_IN_2	ESM0	Pulse	WWDT2 Non-Maskable Interrupt (NMI) Event
		R5FSS1_0_VIM_128	R5FSS1_CORE0		
WWDT3	WWDT3_NMI_REQ	ESM0_PLS_IN_3	ESM0	Pulse	WWDT3 Non-Maskable Interrupt (NMI) Event
		R5FSS1_1_VIM_128	R5FSS1_CORE1		

Note

For more information on the interconnects, see the *System Interconnect* chapter.

For more information on the power, reset and clock management, see the corresponding sections within the *Device Configuration* chapter.

For more information on the device interrupt controllers, see the *Interrupt Controllers* chapter.

13.5.1.4 RTI Functional Description

The RTI# and WWDT# (where # = 0, 1, 2, 3) modules are hereinafter referred to as RTI, RTI_WWDT, or RTI/WWDT.

13.5.1.4.1 RTI Digital Windowed Watchdog

Note

Some of the RTI features described in this section may not be supported on this family of devices. For more information, see , *RTI Not Supported Features*.

Note

Digital windowed watchdog (DWWD) timer is implemented using the digital windowed watchdog function of the RTI modules. Real time interrupt functionality is not supported. In this mode, the timer should default to disabled and user can adjust the period as desired before enabling the watchdog.

In addition to the time-out boundary configurable via the digital watchdog (DWD), some applications may also want to configure the start-time boundary of the watchdog. This is enabled by the digital windowed watchdog (DWWD) feature.

Functional Behavior

The DWWD opens a configurable time window in which the watchdog must be serviced. Any attempt to service the watchdog outside this time window, or a failure to service the watchdog in this time window, will cause the watchdog to generate either a reset or a non-maskable interrupt to the CPU. This is controlled by configuring the RTI_WWDRXNCTRL register. As stated earlier, when the watchdog needs to be enabled by software, the watchdog counter is disabled on a system reset. When the DWWD is configured to generate a non-maskable interrupt on a window violation, the watchdog counter continues to count down. The RTI_INTR_WWD interrupt handler needs to clear the watchdog violation status flag(s) and then service the watchdog by writing the correct sequence in the watchdog key RTI_WDKEY register. This service will cause the watchdog counter to get reloaded from the preload value and start counting down. If the RTI_INTR_WWD handler does not service the watchdog in time, it could count down all the way to zero and wrap around. No second exception for a time out is generated in this case.

Configuration of DWWD

The DWWD preload value (same as DWD preload) can only be configured when the DWWD counter is disabled. The window size and watchdog reaction to a violation can be configured even after the watchdog has been enabled. Any changes to the window size and watchdog reaction configurations will only take effect after the next servicing of the DWWD.

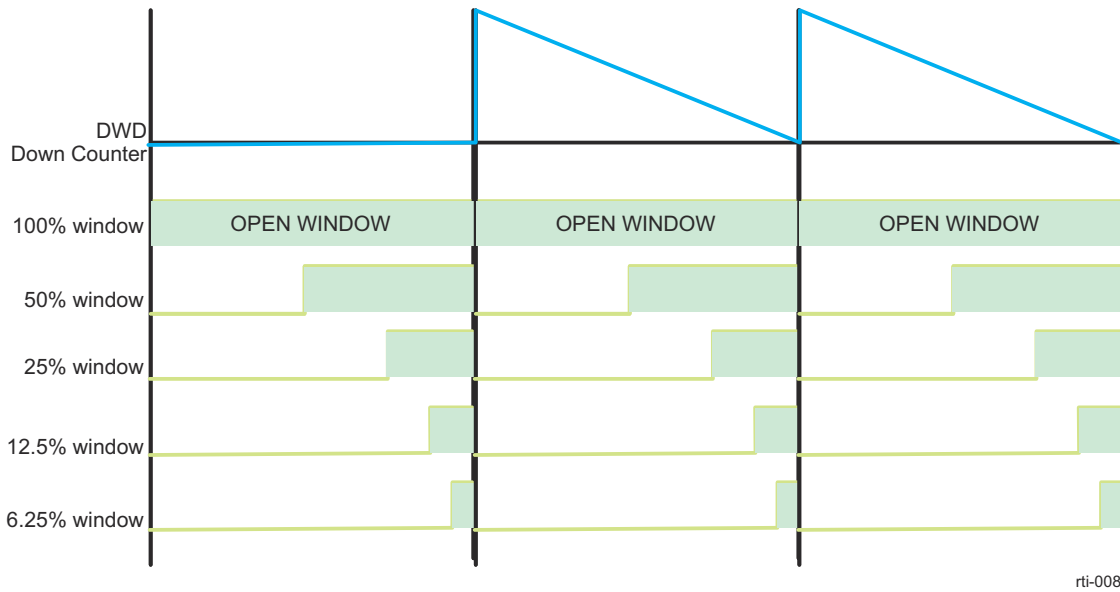
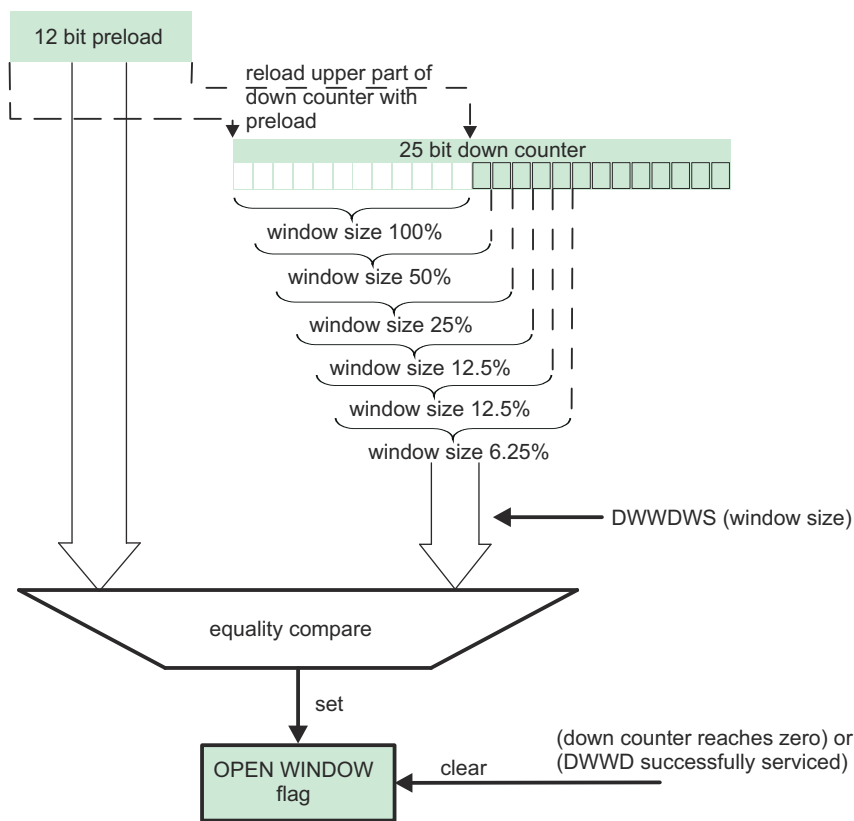

Figure 13-273. RTI Digital Windowed Watchdog Timing Example



rti_009

Figure 13-274. RTI Digital Windowed Watchdog Operation Block Diagram

13.5.1.4.1.1 RTI Debug Mode Behavior

Note

Some of the RTI features described in this section may not be supported on this family of devices. For more information, see , *RTI Not Supported Features*.

Once the system enters debug mode, the behavior of the RTI depends on the RTI_GCTRL[15] COS bit. If the bit is cleared and debug mode is active, all counters will stop operation. If the bit is set to one, all counters will be clocked normally and the RTI will work like in normal mode.

The DWD counter will not decrement in debug mode and will hold its current value, regardless of the RTI_GCTRL[15] COS bit.

Note

The user must not service the watchdog while in debug mode.

13.5.1.4.1.2 RTI Low Power Mode Operation

The operation of the RTI module is guaranteed in run, doze and snooze mode. In sleep or hibernate mode all clocks will be switched off and the RTI module will not work.

In doze and snooze modes all parts of the RTI are active, since it has to be able to wake up the device with compare and timebases interrupts. Capturing events generated by the interrupt module is also possible since in both modes the peripheral modules are able to generate interrupts, which can trigger capture events. The RTI module will generate compare and timebases interrupts. The compare interrupts will periodically wake up the device.

Note

In the special case of doze mode with DPLL off, RTI_FCLK might have a different period than with DPLL enabled, since RTI_FCLK will be derived from the oscillator output. It has to be ensured that the RTI_ICLK to RTI_FCLK ratio is at least 3:1.

The DWD/DWWD remains active when the device enters low power mode as long as the RTI_FCLK is kept active.

Whenever the LPSC that controls an RTI is in any state other than Enable (see , *Module States*), the RTI cannot count or generate interrupts. For more information, see , *Power Control Modules*.

During standard SoC warm reset the RTI and the rest of the SoC are reset. In this case, the RTI counters are stopped and interrupts are not issued. During reset-isolated warm reset, if an R5FSS is put in reset-isolation, then the associated RTI also becomes reset isolated. As such, the R5FSS and the RTI are not reset, but RTI stops counting and cannot generate interrupts until R5FSS is taken out of CLKSTOP (brought to Enable state).

13.5.1.4.2 RTI Digital Watchdog

Note

Some of the RTI features described in this section may not be supported on this family of devices. For more information, see , *RTI Not Supported Features*.

Some applications might use a digital watchdog (DWD) integrated in the RTI module. The digital watchdog generates resets after a programmable period, if no correct key sequence is written to the RTI_WDKEY register. [Figure 13-275](#) shows the digital watchdog functional block.

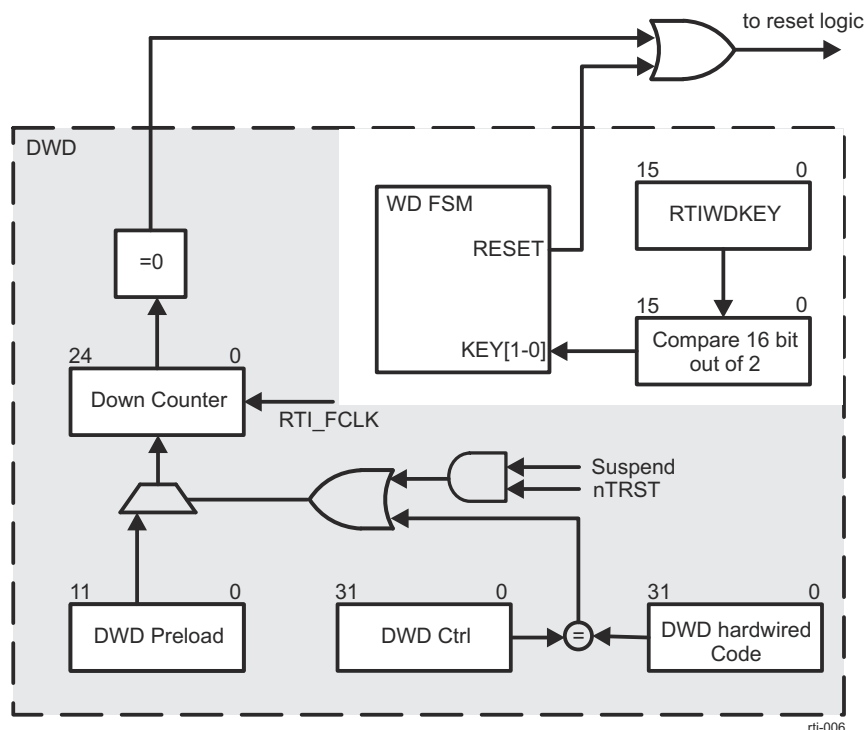

Figure 13-275. RTI Digital Watchdog Functional Block Diagram

The digital watchdog functionality is implemented such that it can be enabled by software.

The DWD starts counting down from the reset value of the RTI_DWDCNTR (DWD Counter Register). The DWD preload register can be configured at any time by the application according to the desired time-out period.

When enabled by software, the digital watchdog is disabled after system reset. If it should be used, it has to be enabled by writing A98559DAh to the RTI_DWDCCTRL register. The DWD timeout period must be configured using the DWD preload register before the DWD is enabled. The DWD cannot be disabled by the application once it is enabled.

Note

When the DWD is enabled by software, any system reset will disable the DWD. This reset could have been generated by the watchdog itself.

If the correct key sequence is written to the RTI_WDKEY register (E51Ah followed by A35Ch), the 25-bit DWD Down Counter is reloaded with the 12-bit preload value stored in RTI_DWDPRLD register. If any incorrect value is written to the RTI_WDKEY register, a watchdog reset will occur immediately. A reset will also be generated, when the DWD Down Counter is decremented to 0.

The user has to take into account that the write to the RTI_WDKEY register takes 3 RTI_ICLK cycles. This needs to be considered for the DWD expiration calculation.

The DWD Down Counter will be decremented with RTI_FCLK frequency. If the RTI_FCLK is switched off via the disable registers of the Clock management, the DWD counter stops decrementing. The DWD module cannot generate a reset under this condition.

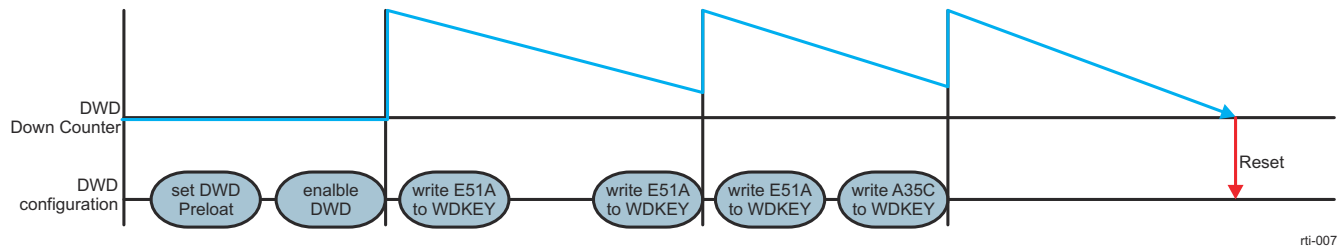

Figure 13-276. RTI Digital Watchdog Operation

The expiration time of the DWD Down Counter can be determined with following equation:

$$t_{exp} = (RTI_DWDPRLD + 1) \times 2^{13} / RTI_FCLK \quad (26)$$

where $RTI_DWDPRLD = 0 \dots 4095$

13.5.1.4.3 RTI Counter Operation

Note

Some of the RTI features described in this section may not be supported on this family of devices. For more information, see , *RTI Not Supported Features*.

Figure 13-277 shows the RTI module counter blocks. The RTI module supports two counter blocks.

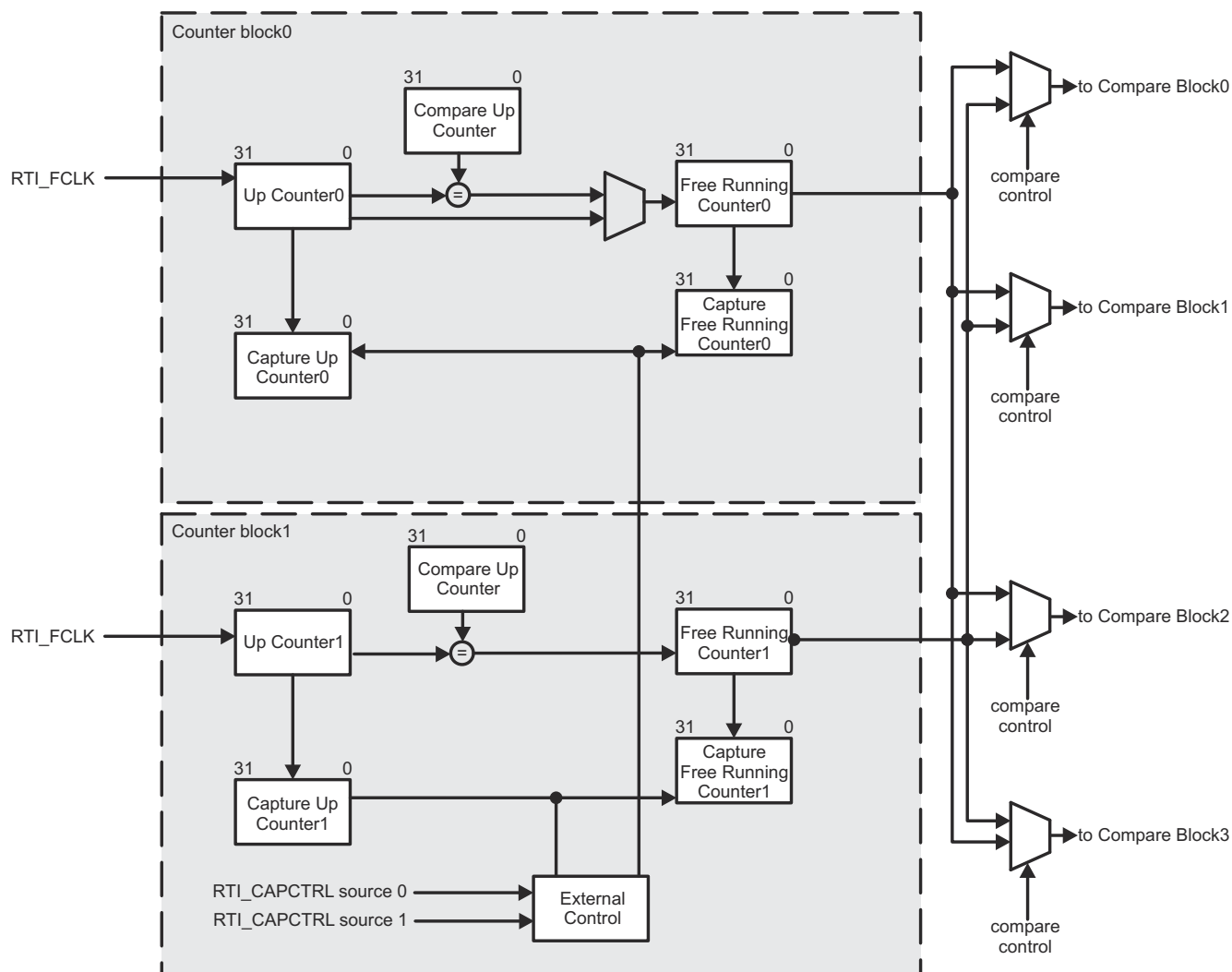

rti-004

Figure 13-277. RTI Counters Block Diagram

Each block consists of two 32 bit up counters - Up Counter (UC) and Free Running Counter (FRC). The Up Counter (RTI_UC0 or RTI_UC1 register) is driven by the RTI_FCLK and counts up until the compare value in the Compare Up Counter register (RTI_CPUC0 or RTI_CPUC1) is reached. When the compare matches, the second counter (RTI_FRC0 or RTI_FRC1 register), which is a free running counter, is incremented. At the same time UCx is reset to zero.

To ensure the consistency of the counters, when both counter value have to be determined, the Free Running Counter has to be read first. This will ensure that at the CPU read cycle, the Up Counter value is stored in the counter register. The second read is done on the Up Counter register, which holds then the value of the counter cycle of the previous read on the Free Running Counter register.

Both blocks provide also a capture feature on external events. Two capture sources can trigger the capture event. Which event triggers block 0 or block 1 is configurable from the RTI_CAPCTRL register. The sources are coming from the interrupt manager, in order to be able to generate a capture event when one of the peripheral modules has generated an interrupt. The peripheral, which can generate an event is configured in the interrupt manager. When the event is detected, UCx and FRCx are stored in Capture Up Counter (RTI_CAUC0 or RTI_CAUC1) and Capture Free Running Counter (RTI_CAFRC0 or RTI_CAFRC1) registers. The read order of the captured values has to be like the order of the actual counters. So the CAFRCx has to be read first and the CAUCx registers has to be read after the CAFRCx value was determined. While the CAFRCx is read the CAUCx value is loaded into a shadow register to ensure data consistency, if during the two reads of the captured data

another capture event happens. If the application fails to read the two registers before a second capture event happens, the previous data will be overwritten.

Figure 13-278 shows the block diagram for one compare block. The RTI module supports four compare blocks.

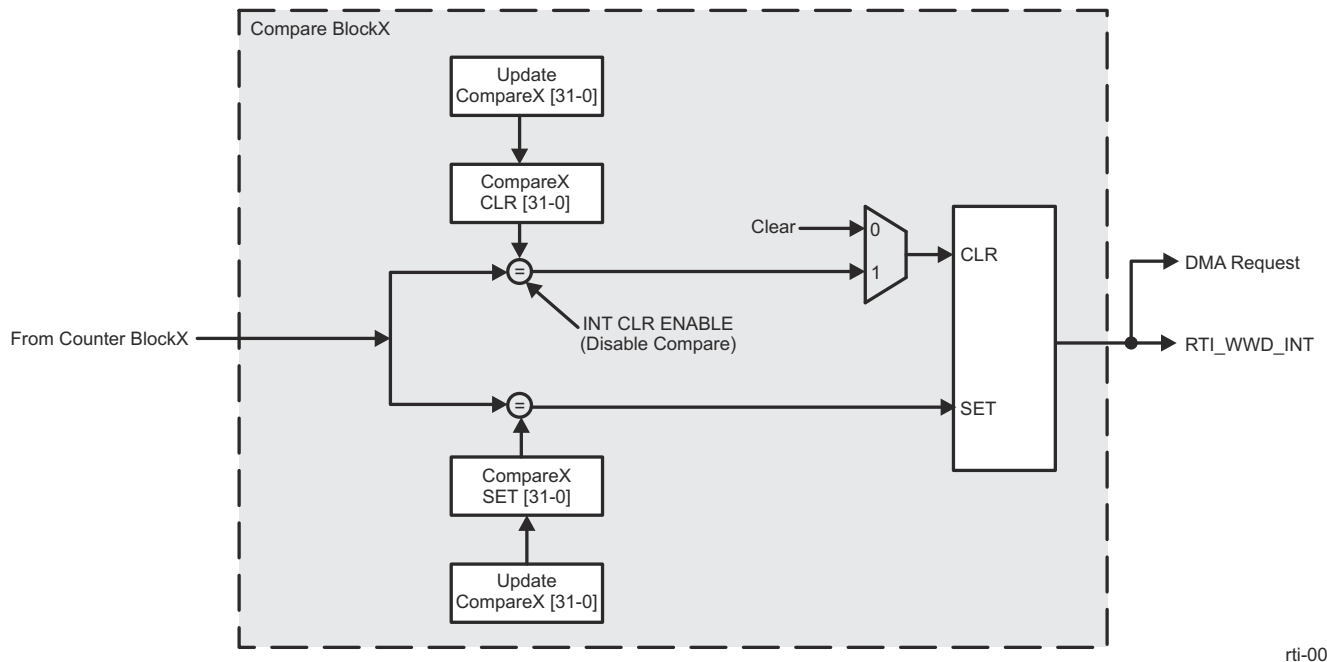

Figure 13-278. RTI Compare Block Diagram

In order to generate interrupt requests to the interrupt manager, there are four compare registers (RTI_COMP0, RTI_COMP1, RTI_COMP2, and RTI_COMP3). Each of the compare registers can be configured to work either on FRC0 (Counter block0) or FRC1 (Counter block1). When the counter value matches the compare value, an interrupt is generated. This sets an interrupt request line to the interrupt manager. The compare value gets updated automatically with the value stored in Update Compare (RTI_UDCP0, RTI_UDCP1, RTI_UDCP2, and RTI_UDCP3) registers when the compare matches. This gives the ability to generate periodic interrupts/DMA requests without having to update the compare value by software.

An optional feature allows an application to program another compare value which is then used to clear the interrupt request line. This feature is supported by four compare clear registers (RTI_COMP0CLR, RTI_COMP1CLR, RTI_COMP2CLR, and RTI_COMP3CLR). When the counter value matches the compare clear value, the interrupt line is cleared. This clears the interrupt request line to the interrupt manager. The compare clear value gets updated automatically with the value stored in Update Compare (RTI_UDCPx) registers when the compare matches.

13.6 Internal Diagnostics Modules

This section describes the internal diagnostics modules in the device.

13.6.1 Dual Clock Comparator (DCC)	1463
13.6.2 ECC Aggregator	1474
13.6.3 Error Signaling Module (ESM)	1482
13.6.4 Memory Cyclic Redundancy Check (MCRC) Controller	1498
13.6.5 Self-Test Controller (STC)	1512

13.6.1 Dual Clock Comparator (DCC)

This section describes the Dual Clock Comparator (DCC) modules in the device.

13.6.1.1 DCC Overview

The Dual Clock Comparator (DCC) is used to determine the accuracy of a clock signal during the time execution of an application. Specifically, the DCC is designed to detect drifts from the expected clock frequency. The desired accuracy can be programmed based on calculation for each application. The DCC measures the frequency of a selectable clock source using another input clock as a reference.

The device has instances of DCC modules. shows DCC modules allocation across device domains.

13.6.1.1.1 DCC Features

The DCC uses two independent clock sources to detect when one is out of specification. Each DCC module implements the following features:

- Two independent counter blocks count clock pulses from each clock source
- Each counter block is programmable, however, for proper operation the counters must be programmed with seed values that respect the ratio of the two clock frequencies
- Configurable timebase for error signal
- Error signal generation when one of the clocks is out of specification
- Clock frequency measurement

13.6.1.1.2 DCC Not Supported Features

The DCC does not support the following features:

- Debug suspend functionality deprecated . Software will have to disable DCCs if it starts messing with clocks during debug.

13.6.1.2 DCC Integration

This section describes the DCC integration in the device, including information about clocks, resets, and hardware requests.

13.6.1.2.1 DCC Integration

There are 4x DCC modules integrated in the device. The diagram below provides a visual representation of the device integration details.

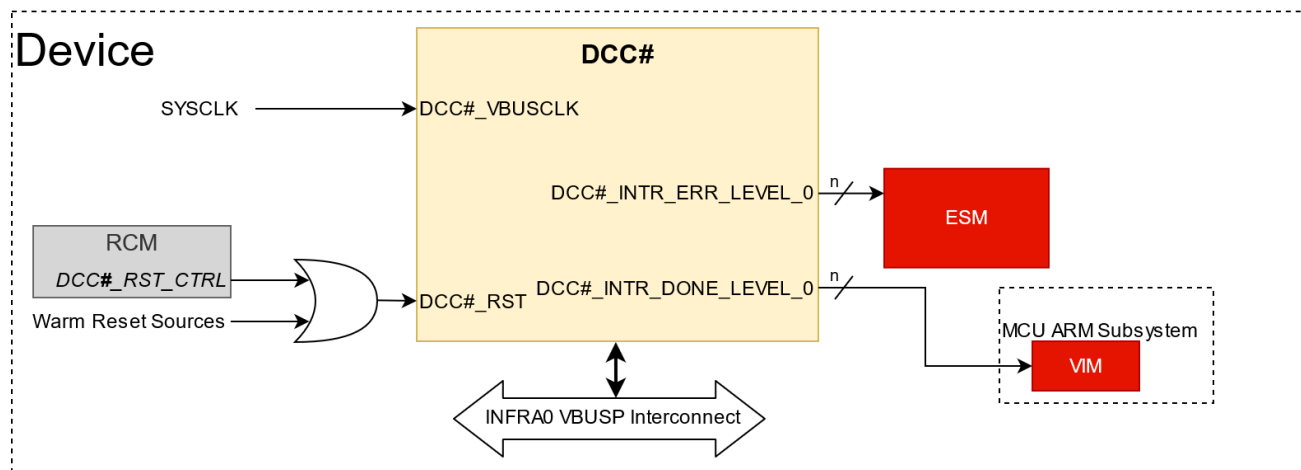

Figure 13-279. DCC Integration Diagram

The tables below summarize the device integration details of DCC.

Table 13-291. DCC Device Integration

This table describes the module device integration details.

Module Instance	Device Allocation	SoC Interconnect
MAIN_DCC0	✓	INFRA0 VBUSP Interconnect
MAIN_DCC1	✓	INFRA0 VBUSP Interconnect
MAIN_DCC2	✓	INFRA0 VBUSP Interconnect
MAIN_DCC3	✓	INFRA0 VBUSP Interconnect

Table 13-292. DCC Clocks

This table describes the module clocking signals.

Module Instance	Module Clock Input	Source Clock Signal	Source	Default Freq	Description
MAIN_DCC0	MAIN_DCC0_CLK (VBUSP_CLK)	SYS_CLK	PLL_CORE_CLK: HSDIV0_CLKOUT0	200 MHz	MAIN_DCC0 Interface Clock
MAIN_DCC1	MAIN_DCC1_CLK (VBUSP_CLK)	SYS_CLK	PLL_CORE_CLK: HSDIV0_CLKOUT0	200 MHz	MAIN_DCC1 Interface Clock
MAIN_DCC2	MAIN_DCC2_CLK (VBUSP_CLK)	SYS_CLK	PLL_CORE_CLK: HSDIV0_CLKOUT0	200 MHz	MAIN_DCC2 Interface Clock
MAIN_DCC3	MAIN_DCC3_CLK (VBUSP_CLK)	SYS_CLK	PLL_CORE_CLK: HSDIV0_CLKOUT0	200 MHz	MAIN_DCC3 Interface Clock

Table 13-293. DCC Resets

This table describes the module reset signals.

Module Instance	Module Reset Input	Source Reset Signal	Source	Description
MAIN_DCC0	MAIN_DCC0_RST	Warm Reset (SYNC_RST_N)	RCM + Warm Reset Sources	Synchronous Assertion Reset, Active Low
MAIN_DCC1	MAIN_DCC1_RST	Warm Reset (SYNC_RST_N)	RCM + Warm Reset Sources	Synchronous Assertion Reset, Active Low
MAIN_DCC2	MAIN_DCC2_RST	Warm Reset (SYNC_RST_N)	RCM + Warm Reset Sources	Synchronous Assertion Reset, Active Low
MAIN_DCC3	MAIN_DCC3_RST	Warm Reset (SYNC_RST_N)	RCM + Warm Reset Sources	Synchronous Assertion Reset, Active Low

Table 13-294. DCC Interrupt Requests

This table describes the module interrupt requests.

Module Instance	Module Interrupt Signal	Destination Interrupt Input	Destination	Type	Description
MAIN_DCC0	DCC0_done	DCC0_done	ALL R5FSS Cores	Level	DCC Done Interrupt
	DCC0_error	DCC0_error	ESM	Level	DCC Error Interrupt
MAIN_DCC1	DCC1_done	DCC1_done	ALL R5FSS Cores	Level	DCC Done Interrupt
	DCC1_error	DCC1_error	ESM	Level	DCC Error Interrupt
MAIN_DCC2	DCC2_done	DCC2_done	ALL R5FSS Cores	Level	DCC Done Interrupt
	DCC2_error	DCC2_error	ESM	Level	DCC Error Interrupt
MAIN_DCC3	DCC3_done	DCC3_done	ALL R5FSS Cores	Level	DCC Done Interrupt
	DCC3_error	DCC3_error	ESM	Level	DCC Error Interrupt

Note

For more information on the interconnects, see the *System Interconnect* chapter.

For more information on power, reset, and clock management, see the corresponding sections within the *Device Configuration* chapter.

For more information on the device interrupt controllers, see the *Interrupt Controllers* chapter.

[DCC0 - DCC1 Input Source Clock Mapping](#) and [DCC2 - DCC3 Input Source Clock Mapping](#) summarizes the DCC input source clocks in the device.

Table 13-295. DCC0 - DCC1 Input Source Clock Mapping

	Input:	MAIN_DCC0												MAIN_DCC1											
		Input0				Input1								Input0				Input1							
		MUX0				MUX1								MUX0				MUX1							
		/ value:	0	1	2	3	0	1	2	3	4	5	6	7	0	1	2	3	0	1	2	3	4	5	6
Clock Source		CL OC K0[0]	CL OC K0[1]	CL OC K0[2]	CL OC K0[3]	CL OC K1[0]	CL OC K1[1]	CL OC K1[2]	CL OC K1[3]	CL OC K1[4]	CL OC K1[5]	CL OC K1[6]	CL OC K1[7]	CL OC K0[0]	CL OC K0[1]	CL OC K0[2]	CL OC K0[3]	CL OC K1[0]	CL OC K1[1]	CL OC K1[2]	CL OC K1[3]	CL OC K1[4]	CL OC K1[5]	CL OC K1[6]	CL OC K1[7]
XTALCLK	Crystal Clock	✓							✓					✓											
RCCLK10M	Internal 10 MHz RC Oscillator. Always on			✓												✓						✓			
EXT_REFCLK	External Ref Clock		✓						✓					✓											
RCCLK32K	32 KHz RC Clock				✓						✓					✓									

Table 13-295. DCC0 - DCC1 Input Source Clock Mapping (continued)

		MAIN_DCC0														MAIN_DCC1													
		Input0				Input1										Input0				Input1									
		MUX0				MUX1										MUX0				MUX1									
		/ value:	0	1	2	3	0	1	2	3	4	5	6	7	0	1	2	3	0	1	2	3	4	5	6	7			
Clock Source	Input:	CL OC K0[0]	CL OC K0[1]	CL OC K0[2]	CL OC K0[3]	CL OC K1[0]	CL OC K1[1]	CL OC K1[2]	CL OC K1[3]	CL OC K1[4]	CL OC K1[5]	CL OC K1[6]	CL OC K1[7]	CL OC K0[0]	CL OC K0[1]	CL OC K0[2]	CL OC K0[3]	CL OC K1[0]	CL OC K1[1]	CL OC K1[2]	CL OC K1[3]	CL OC K1[4]	CL OC K1[5]	CL OC K1[6]	CL OC K1[7]				
PLL_CORE_CLKOUT (PLL_CORE)																													
DPLL_CORE_HSDIV0_CLKOUT0	Root clock for Processor SS and Interconnect (Not Mapped to DCC - covered by SYS_CLK below)																												
DPLL_CORE_HSDIV0_CLKOUT1	CPSW2G/ICSSG RGMII/GMII Clock																			✓									
PLL_PER_CLKOUT (PLL_PER)																													
DPLL_PER_HSDIV0_CLKOUT0	UART 5mbps Clocking																			✓									
DPLL_PER_HSDIV0_CLKOUT1	Peripheral Clocking																					✓							
Other IP Clocks																													
R5SS0_CLK	R5 Cluster 0 Clock						✓																						
R5SS1_CLK	R5 Cluster 1 Clock							✓																					
SYS_CLK	Interconnect System Clock					✓																							
WDT0_CLK	Watch Dog Timer																												
WDT1_CLK	Watch Dog Timer																												
WDT2_CLK	Watch Dog Timer																												
WDT3_CLK	Watch Dog Timer																												
MCAN0_CLK	MCAN Clock																												
MCAN1_CLK	MCAN Clock																												
TEMPSense_32K_CLK	32 KHz Clock (divided down from XTALCLK)																												
RMII1_REFCLK	IO Reference Clock Input																												
RMII2_REFCLK	IO Reference Clock Input																												
RGMII1_RXC	IO Receive clock input																												
RGMII2_RXC	IO Receive clock input																												
MII1_RXCLK	IO Receive clock input																												
MII2_RXCLK	IO Receive clock input																												
PR0_MII0_RXCLK	IO Receive clock input																												
PR0_MII1_RXCLK	IO Receive clock input																												
FSI0_RX_CLK	IO Receive clock input																						✓						
FSI1_RX_CLK	IO Receive clock input																							✓					
FSI2_RX_CLK	IO Receive clock input																								✓				
FSI3_RX_CLK	IO Receive clock input																									✓			

Table 13-296. DCC2 - DCC3 Input Source Clock Mapping

DCC_CLKSRC0 / DCC_CLKSRC1 value:		MAIN_DCC2											MAIN_DCC3											
		Input0			Input1								Input0			Input1								
		MUX0			MUX1								MUX0			MUX1								
		[0, 3-F]	1	2	0	1	2	3	4	5	6	7	[0, 3-F]	1	2	0	1	2	3	4	5	6	7	
Clock Source	Input:	CL OC K0[0]	CL OC K0[1]	CL OC K0[2]	CL OC K1[0]	CL OC K1[1]	CL OC K1[2]	CL OC K1[3]	CL OC K1[4]	CL OC K1[5]	CL OC K1[6]	CL OC K1[7]	CL OC K0[0]	CL OC K0[1]	CL OC K0[2]	CL OC K1[0]	CL OC K1[1]	CL OC K1[2]	CL OC K1[3]	CL OC K1[4]	CL OC K1[5]	CL OC K1[6]	CL OC K1[7]	
XTALCLK	Crystal Clock	✓											✓											
RCCLK10M	Internal 10 MHz RC Oscillator. Always on			✓											✓									
EXT_REFCLK	External Ref Clock		✓											✓										
RCCLK32K	32 KHz RC Clock																							
PLL_CORE_CLKOUT (PLL_CORE)																								
DPLL_CORE_HSDIV0_CLKOUT 0	Root clock for Processor SS and Interconnect (Not Mapped to DCC - covered by SYS_CLK below)																							
DPLL_CORE_HSDIV0_CLKOUT 1	CPSW2G/ICSSG RGMII/GMII Clock																							
PLL_PER_CLKOUT (PLL_PER)																								
DPLL_PER_HSDIV0_CLKOUT0	UART 5mbps Clocking																							
DPLL_PER_HSDIV0_CLKOUT1	Peripheral Clocking																							
Other IP Clocks																								
R5SS0_CLK	R5 Cluster 0 Clock																							
R5SS1_CLK	R5 Cluster 1 Clock																							
SYS_CLK	Interconnect System Clock				✓																			
WDT0_CLK	Watch Dog Timer					✓																		
WDT1_CLK	Watch Dog Timer						✓																	
WDT2_CLK	Watch Dog Timer							✓																
WDT3_CLK	Watch Dog Timer								✓															
MCAN0_CLK	MCAN Clock									✓														
MCAN1_CLK	MCAN Clock										✓													
TEMPSENSE_32K_CLK	32 KHz Clock (divided down from XTALCLK)											✓												
RMII1_REFCLK	IO Reference Clock Input														✓									
RMII2_REFCLK	IO Reference Clock Input															✓								
RGMII1_RXC	IO Receive clock input																✓							
RGMII2_RXC	IO Receive clock input																	✓						
MII1_RXCLK	IO Receive clock input																		✓					
MII2_RXCLK	IO Receive clock input																			✓				
PR0_MII0_RXCLK	IO Receive clock input																						✓	
PR0_MII1_RXCLK	IO Receive clock input																							✓
FSI0_RX_CLK	IO Receive clock input																							
FSI1_RX_CLK	IO Receive clock input																							
FSI2_RX_CLK	IO Receive clock input																							

Table 13-296. DCC2 - DCC3 Input Source Clock Mapping (continued)

DCC_CLKSRC0 / DCC_CLKSRC1 value:		MAIN_DCC2											MAIN_DCC3											
		Input0			Input1								Input0			Input1								
		MUX0			MUX1								MUX0			MUX1								
		[0, 3-F]	1	2	0	1	2	3	4	5	6	7	[0, 3-F]	1	2	0	1	2	3	4	5	6	7	
Clock Source	Input:		CL OC K0[0]	CL OC K0[1]	CL OC K0[2]	CL OC K1[0]	CL OC K1[1]	CL OC K1[2]	CL OC K1[3]	CL OC K1[4]	CL OC K1[5]	CL OC K1[6]	CL OC K1[7]	CL OC K0[0]	CL OC K0[1]	CL OC K0[2]	CL OC K1[0]	CL OC K1[1]	CL OC K1[2]	CL OC K1[3]	CL OC K1[4]	CL OC K1[5]	CL OC K1[6]	CL OC K1[7]
FSI3_RX_CLK	IO Receive clock input																							

13.6.1.3 DCC Functional Description

Figure 13-280. DCC Functional Block Diagram

13.6.1.3.1 DCC Counter Operation

Note

For detailed DCC compute calculations, refer to [Continuous Monitor of the PLL Frequency With the DCC App Note](#).

The DCC has two parallel counters that count clock pulses for two independent clock sources:

- Counter0 generates a fixed-width counting window (VALID0) after a pre-programmed number of pulses (COUNT0). This window is meant to be at least four cycles wide. The values for VALID0 and COUNT0 can be programmed in and registers respectively. Do not program a value less than '4' into the VALID0 register
- Counter1 generates a fixed-width pulse (1 cycle) after a pre-programmed number of pulses (COUNT1). This pulse sets an error signal if Counter1 does not reach 0 during the time when VALID0 is running. The seed value for COUNT1 can be programmed in register.

The error signal is generated by any one of the following conditions:

- Clock1 expires before the COUNT0 reaches 0.
- Clock1 expires after both COUNT0 and VALID0 reach 0.
- Clock1 not present.
- Clock0 not present.

Any of these errors causes the counters to stop counting. An application must then read out the counter values to determine what caused the error. Once the error is detected, the counters are stopped. It would take multiple clocks(2-3 in each clock domain i.e. source & VBUSP_CLK) to stop the counters due the cross clock domain synchronisations. Counters can be configured in a mode to reload and continue down-counting despite error so successive error event is not missed. Error is reported as exception and application is expected to read the counter values for determining quantum & direction of error.

Note

Reads of the counter value may not be exact since the read operation is synchronized to the VBUSP_CLK

Reloads or restarts occur under two conditions:

- The module is reset or restarted through software (that is, software starts the module after reset, or software checks an error condition and decides to restart the module).
- COUNT0, COUNT1, and VALID0 all reach 0 without error.

CAUTION

The DCC module does not check jitter for Clock0 or Clock1.

As the counter preset signal is synchronized to either of the source clock domains, the counters begin downcounting after two corresponding source clock cycles.

The error signal is to be captured to the VBUSP_CLK domain. There is 1 VBUSP_CLK period uncertainty on either side of the fixed width counting window (VALID0) in generating the error signal since the counters work in a different clock domain. This should be accounted for, when setting the count value for VALID0.

Operating the DCC with '0' in the COUNTSEED1 or COUNTSEED0 or VALIDSEED0 register will result in undefined operation

Figure 13-281 through Figure 13-285 shows examples of counters relationship and error generation.

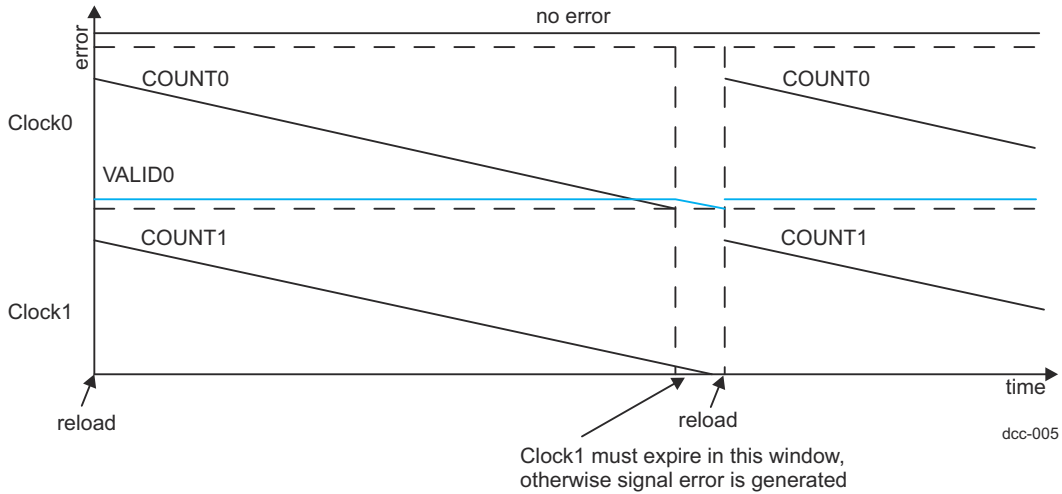

Figure 13-281. DCC Clock0 and Clock1 With no Error

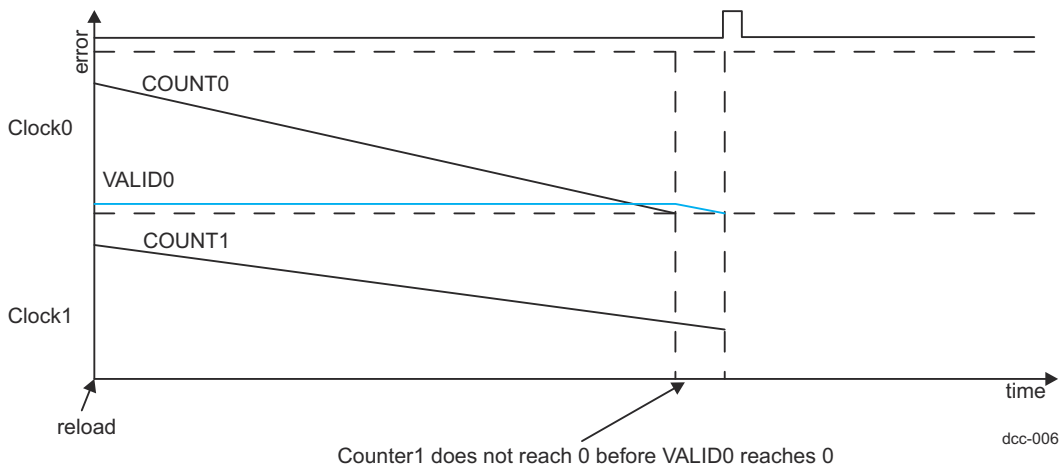

Figure 13-282. DCC Clock1 slower than Clock0 results in an error and stops counting

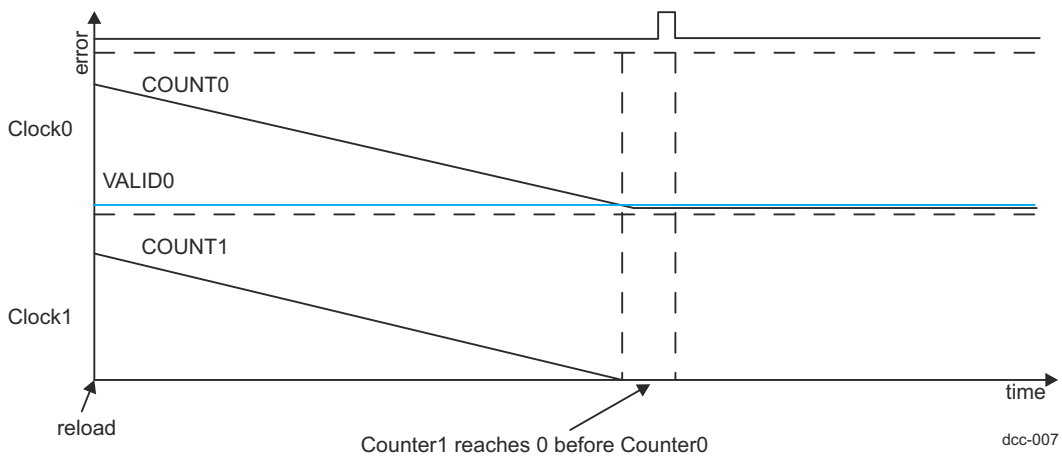

Figure 13-283. DCC Clock1 faster than Clock0 results in an error and stops counting

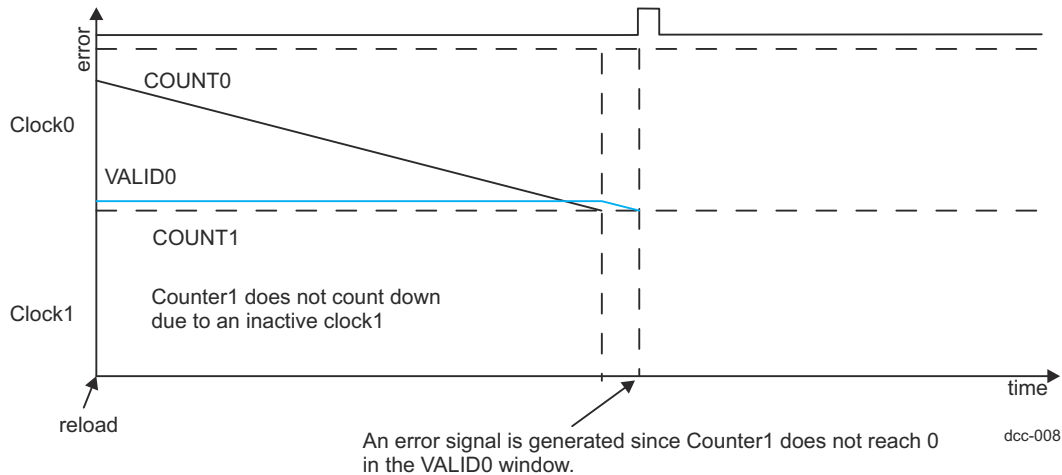

Figure 13-284. DCC Clock1 not present results in an error and stops counting

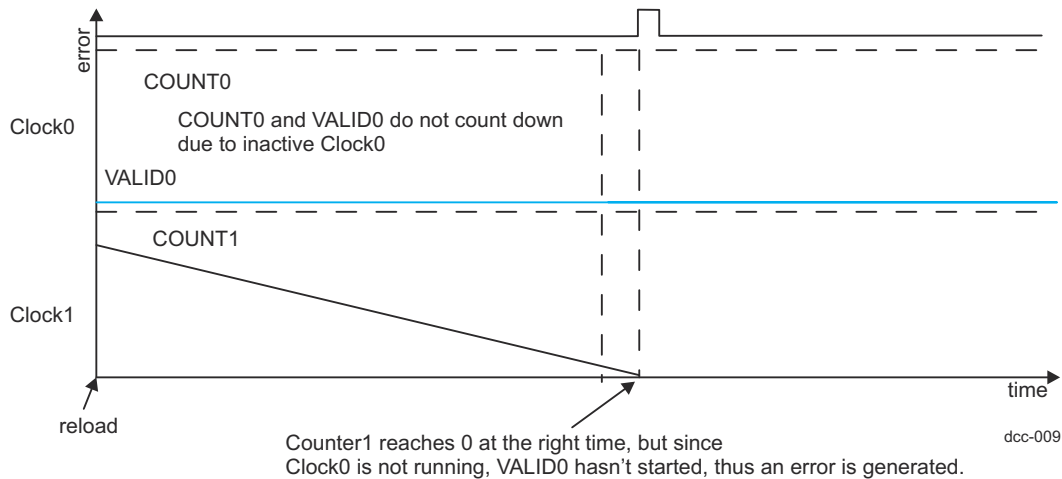

Figure 13-285. DCC Clock0 not present results in an error and stops counting

13.6.1.3.2 Limp Mode Generation

A dedicate coarse clock loss logic checks the XTAL clock against the RC CLK continuously to detect if the XTAL clock is toggling and LIMP_MODE_EN_XTALCLK_LOSS_EN register is enabled.

When this module detects a clock error on XTAL Clock, the error signal is routed to the GCM's to activate the Limp mode. When the limp mode is activated, all the GCM switch to RCCLK. This ensures the CPU continues to operate even if the XTAL Clock fails and can take the system to a safe state.

Error on DCC0 and CORE_PLL Phase lock loss can also trigger Limp-mode for added safety. This feature can be enabled by the bits TOP_RCM.LIMP_MODE_EN.COREPLL_LOSS_EN and TOP_RCM.LIMP_MODE_EN.DCC0_ERROR_EN

13.6.1.3.3 DCC Low Power Mode Operation

The DCC module does not function in Low Power Mode. It is the responsibility of software to stop the module before entering low power mode and to restart the module after exiting low power mode.

13.6.1.3.4 DCC Suspend Mode Behavior

The DCC module will continue running regardless of the state of emulation. All registers are readable via emulation reads.

13.6.1.3.5 DCC Single-Shot Mode

The DCC can be programmed to count down one time using single-shot mode. In this mode, the DCC stops operation when both COUNT0 and VALID0 reach 0.

At the end of one sequence in single-shot mode the [3-0] DCCENA bitfield is set to disabled, which stops further counting. Single-shot mode is enabled from the [11-8] SINGLESHOT bitfield.

At the end of one sequence in single-shot mode, if there is no error which stops counting, then the done status bit is set in the [1] DONEFLG bitfield and a done interrupt is generated. Software must clear the done bit before restarting the counting.

Note

DCCENA reflects the running state of the module and setting this bit to 1 will reload the counters and starts counting. It is advised to program this bit only after programming all other registers for DCC

13.6.1.3.6 DCC Continuous mode

When DCC runs in continuous mode both the counts shall get reloaded with seed value upon completion of counts without error. If the counts end in error DCC stops the operation and counts are not reloaded.

13.6.1.3.6.1 DCC Continue on Error

During debug, if there are events which are causing clocks to be anomalous over short period covering more than one evaluation window then it would be important to capture trajectory of error event and period around such event. To allow capturing the successive error events DCC can be programmed to continue after error. [3-0] CONT_ON_ERR shall be set to value other than "0101" to enable this mode. It is recommended to write "1010" to avoid single soft errors.

13.6.1.3.6.2 DCC Error Count

DCC also counts the number of error pulses generated since reset or since last time the error count is cleared. This is read/write register for CPU to clear when new trace of number of errors is required to be maintained.

13.6.1.3.7 DCC Control and count hand-off across clock domains

As the counters run in two different selectable clock domains and the register interface runs on the fixed bus clock domain, control signals and counter value hand-off have synchronizers implemented. These add to the margins of error while comparing the counts.

1. With all three counts synchronized to Functional Interface Clock (FICLK) domain for comparison error detection there is delay in terms of FICLK domain.
2. Based on the error signal, the enable for the counters is synchronized back to the respective clock domains of the counters, which adds latency in terms of clock periods which are different, this would create a skew between start of count. Depending upon frequency ratios of the clocks used, the difference between two could vary.

Application needs to consider the worst case delay differences while measuring the clocks.

13.6.1.3.8 DCC Error Trajectory record

Once the clock errors out, the host can read the counter values to determine the extent of error to analyze type of failure. For short window comparisons this would become difficult, specially if there are back to back errors due to some transient event. Secondly, for random events which can cause an interrupt during the critical phase of application running, then event if not recorded may get overwritten and also not provide meaningful trace of error.

13.6.1.3.8.1 DCC FIFO capturing for Errors

DCC provides the FIFO for capturing COUNT0, VALID0, and COUNT1 information which captures all three counts upon "Error" event. For "Done" event no results are captured by default.

CAUTION

Currently, DCC can't be used to monitor faults in SYS_CLK

13.6.1.3.8.2 DCC FIFO in continuous capture mode

To track the VALID0 counter values regardless of "Error" or not, FIFOs can be configured to capture the count for each compare window. This is useful in validation and characterization exercise. [11-7] FIFO_NONERR control when set to value other than "0101" this mode is set; it is recommended to write "1010" to avoid single soft errors. Note, this capture is applicable only in continuous mode and not in single shot mode.

13.6.1.3.8.3 DCC FIFO Details

The FIFO is 4 deep for each count and updates new count information for all the non-full FIFOs. Information is updated on every configured trigger of error or cycle completion. If full, the next values are not written till at-least one entry is read. Application owns responsibility to read the FIFOs uniformly to keep synchronisation between three entries of the FIFO. Both empty and full indications for individual FIFOs is provided through the DCCSTATUS2.

13.6.1.3.8.4 DCC FIFO Debug mode behavior

Upon debug access, the FIFO pointers should not advance hence not impacting the functional behavior. This requirement is same as other functional blocks in the device.

13.6.1.3.9 DCC Count read registers

DCC has provision to read the counts during operation. This is performed using DCCCNT0, DCCVALID0, , and DCCCNT1 registers. Read from these registers in default mode allows reading the present value of count. This is useful when in single shot mode or mode where DCC stops upon error.

These registers can be used to read the FIFO through the [7-4] FIFO_READ configuration. Reads on the empty FIFO shall provide the contents of last pointed location. Application shall track the empty/full conditions of the FIFOs to track the count records consistently.

Regardless of FIFO_READ configuration, the FIFO internally keeps updating records based on configured triggers until full.

Note

Input0_clk and input1_clk are two asynchronous clock domains. In a system, VBUS clock may also be asynchronous relative to both Input0_clk and Input1_clk. The module must be able to generate an error when either Input0_clk or Input1_clk is not present. VBUS clock should not sample or affect the clock counting logic in any way.

In general, the reference clock should be hooked up to Input0_clk and measured clock should be connected to Input1_clk. The default clock source i.e. '0' should be assigned to connect with device native clock such as internal oscillator reference on both.

The error interrupt signal is independent of the error flag bit. If the interrupt is masked, the error flag is still set when an error occurs. The error flag stays set until it is cleared, regardless of the status of the interrupt.

The done flag in the DCCSTAT register would be set when the single shot mode completes without error and is independent of the DONEENA bits in the DCCGCTRL register. The done level interrupt would be set only if it is enabled by the DONEENA bits.

13.6.2 ECC Aggregator

This section describes the common ECC aggregator functionality.

13.6.2.1 ECC Aggregator Overview

To increase functional and system reliability the memories (for example, FIFOs, queues, SRAMs and others) in many device modules and subsystems are protected by error correcting code (ECC). This is accomplished through an ECC aggregator and ECC wrapper. The ECC aggregator is connected to these memories (hereinafter ECC RAMs) and involved in the ECC process. Each memory is surrounded by an ECC wrapper which performs the ECC detection and correction. The wrapper communicates via serial interface with the aggregator which has memory mapped configuration interface.

The ECC aggregator is also connected to interconnect ECC components that protect the command, address and data buses of the system interconnect. ECC is calculated for the data bus and parity and redundancy for the command and address buses. Each interconnect ECC component has the same serial interface for communication with the aggregator as the ECC wrapper. An ECC aggregator may be connected to both endpoints - the ECC wrapper and interconnect ECC component.

The ECC aggregator, ECC wrapper and interconnect ECC component are considered as single entity and are hereinafter referred to as ECC aggregator unless otherwise explicitly specified.

lists the device modules and subsystems which have ECC aggregator.

Table 13-297. Device Modules and Subsystems with ECC Aggregator

This table lists the device modules and subsystems which have an ECC aggregator

Module Instance	ECC Aggregator Support	RAM ID Number
SoC/Interconnect	✓	Not Applicable
R5FSS0-0	✓	See <i>R5FSS ECC Support</i>
R5FSS0-1	✓	See <i>R5FSS ECC Support</i>
R5FSS1-0	✓	See <i>R5FSS ECC Support</i>
R5FSS1-1	✓	See <i>R5FSS ECC Support</i>
ICSSM	✓	See <i>PRU_ICSSM RAM Index Allocation</i>
MCAN0	✓	1
MCAN1	✓	1
MCAN2	✓	1
MCAN3	✓	1
CPSW3G	✓	See <i>Memory Error Detection and Correction</i>

13.6.2.1.1 ECC Aggregator Features

The ECC aggregator has the following features:

- Reduces memory software errors via single error correction (SEC) and double error detection (DED)
- Provides a mechanism to control and monitor the ECC protected memories in a module or subsystem
- SEC and DED over the system interconnect data bus and parity and redundancy for the system interconnect command and address buses
- Generates an interrupt for correctable error
- Generates an interrupt for non-correctable error
- Supports inject only mode for diagnostic purposes
- Supports software readable status for single and double-bit ECC errors and associated information such as row address where error has occurred and data bits that have been flipped
- Supports up to 256 ECC endpoints. An ECC endpoint can be either ECC RAM or interconnect ECC component.
- Detects single bit error via parity checking on:
 - Memory mapped configuration interface FIFO
 - Serial interface FIFO
 - Serial interface transaction
- Single bit error detection via parity checking results in a non-correctable error interrupt
- Supports timeout mechanism on transactions over the ECC serial interface. Timeout occurrence results in a non-correctable error interrupt.
- Certain control bits have redundancy and if a bit flips an interrupt is generated

13.6.2.2 ECC Aggregator Integration

This section describes an ECC aggregator integration in the device, including information about clocks, resets, and hardware requests.

Note

For a list of the device modules and subsystems which have ECC aggregator, see Device Modules and Subsystems with ECC Aggregator.

13.6.2.2.1 ECC Aggregator Integration

There is 1x ECC Aggregator integrated in the device. The diagram below provides a visual representation of the device integration details.

Figure 13-286. ECC Aggregator Integration

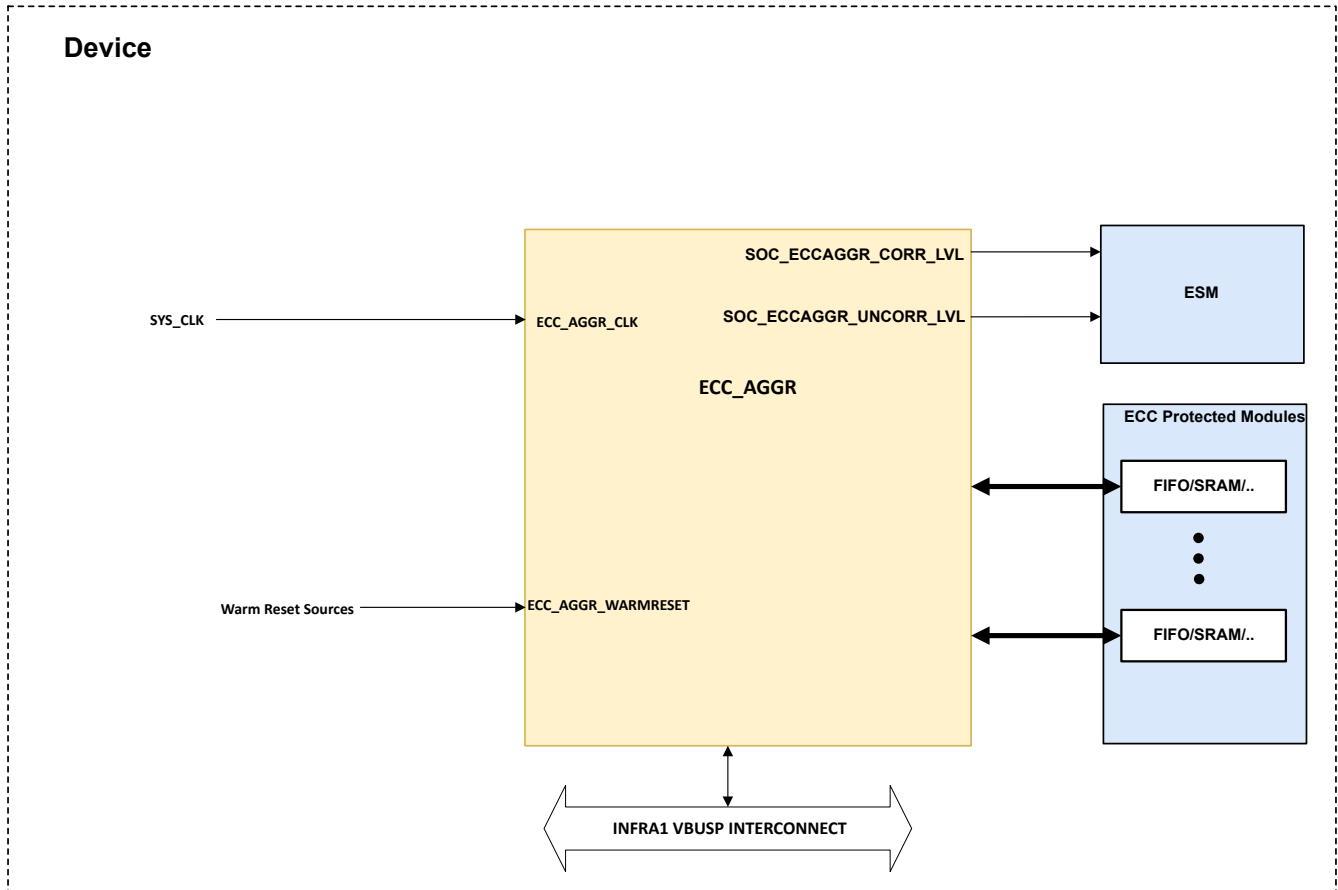

ADVANCE INFORMATION

The tables below summarize the device integration details of ECC Aggregator.

Table 13-298. ECC Aggregator Device Integration

This table describes the ECC Aggregator device integration details.

ECC Aggregator Instance	Device Allocation	SoC Interconnect
ECC Aggregator0	✓	INFRA1 VBUSP Interconnect

Table 13-299. ECC Aggregator Clocks

This table describes the ECC Aggregator clocking signals.

ECC Aggregator Instance	ECC Aggregator Clock Input	Source Clock Signal	Source	Default Freq	Description
ECC Aggregator0	ECC_AGGR_CLK	SYS_CLK	PLL_CORE_CLK: HSDIV0_CLKOUT0	200 MHz	ECC Aggregator Interface Clock

Table 13-300. ECC Aggregator Resets

This table describes the ECC Aggregator reset signals.

ECC Aggregator Instance	ECC Aggregator Reset Input	Source Reset Signal	Source	Description
ECC Aggregator 0	ECC_AGGR_WARMRE SET(VBUSP_RSTn)	Warm Reset (MOD_G_RST)	RCM + Warm Reset Sources	ECC Aggregator0 Asynchronous Reset

Table 13-301. ECC Aggregator Event Requests

This table describes the ECC Aggregator interrupt requests.

ECC Aggregator or Instance	ECC Aggregator Interrupt Signal	Destination Interrupt Input	Destination	Type	Description
ECC Aggregator 0	SOC_ECCAGGR_UNCORR_LVL_0	SOC_ECCAGGR_UNCORR_LVL_0	ESM	Level	ECC Aggregator0 uncorrectable error event
	SOC_ECCAGGR_CORR_LVL_0	SOC_ECCAGGR_CORR_LVL_0			ECC Aggregator0 correctable error event

Table 13-302. Device modules with ECC Aggregator

This table describes the ECC Aggregator interrupt requests.

ECC Aggregator	ECC Aggregator Module instances
ECC Aggregator0	L2OCRAM_BANK0
	L2OCRAM_BANK1
	L2OCRAM_BANK2
	L2OCRAM_BANK3
	MBOX_SRAM
	TPTC00
	TPTC01

Note

For more information on the interconnects, see the *System Interconnect* chapter.

For more information on power, reset, and clock management, see the corresponding sections within the *Device Configuration* chapter.

For more information on the device interrupt controllers, see the *Interrupt Controllers* chapter.

13.6.2.3 ECC Aggregator Functional Description

This section describes the architecture and functional details of the ECC aggregator.

13.6.2.3.1 ECC Aggregator Block Diagram

Figure 13-287 shows the ECC aggregator block diagram.

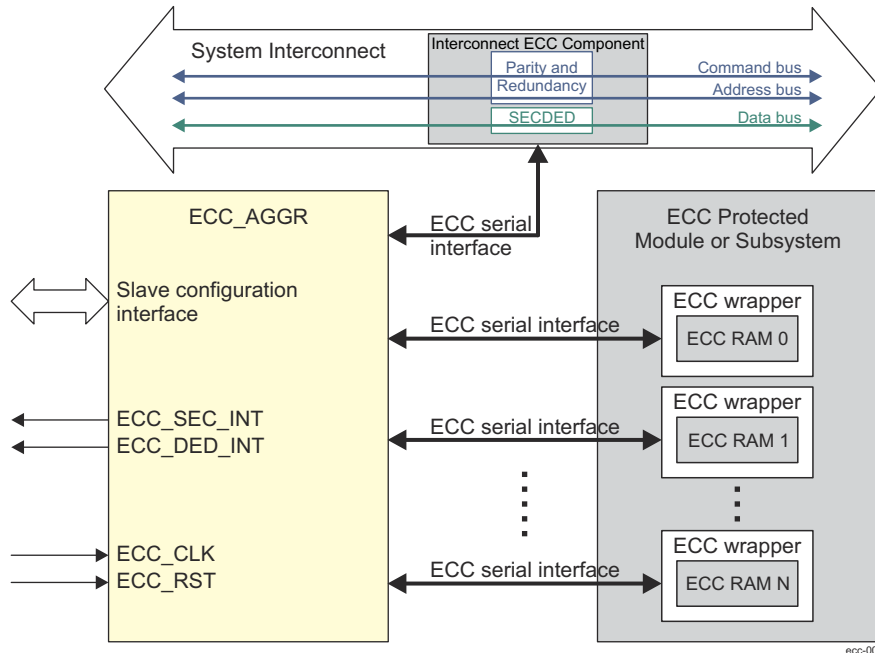

Figure 13-287. ECC Aggregator Block Diagram

The ECC aggregator is connected to one or more ECC endpoints each of which has assigned a unique ID used when the endpoint is accessed for status information or configuration. The ECC aggregator provides software access to all ECC related registers through its memory mapped slave configuration interface while the serial interface is used to communicate with the ECC endpoints. Upon detection of single or double-bit error the corresponding interrupt line is asserted.

13.6.2.3.2 ECC Aggregator Register Groups

The ECC aggregator has ECC control, status and interrupt registers for each ECC endpoint in a module or subsystem. These registers are memory mapped and occupy 1 KB address space although part of it may contain reserved locations. The registers are split in the following types:

- **Global registers.** They are common to all ECC endpoints associated with the ECC aggregator and include the ECC_VECTOR and ECC_REV registers. Each ECC endpoint has assigned a unique ID. When this ID is written to the ECC_VECTOR[10-0] ECC_VECTOR field the corresponding endpoint is selected either for control or for status reading.
- **ECC control and status registers.** These registers are specific to each ECC endpoint and reside in the range from address offset 0x10 to 0x28, if the endpoint is ECC RAM or from 0x10 to 0x24, if the endpoint is interconnect ECC component. They are memory mapped but are accessed through the ECC serial interface. They are also selected by the ECC endpoint ID written to the ECC_VECTOR[10-0] ECC_VECTOR field. Because of latency on the serial interface the ECC control and status registers are read by performing special sequence as described in Section 13.6.2.3.3. These registers have also different functionality for both types of endpoints - ECC RAM and interconnect ECC component.
- **Interrupt registers.** They include interrupt status, interrupt enable, interrupt disable, and EOI registers. For more information, see Section 13.6.2.3.5.

Note

For description of each register, see .

13.6.2.3.3 Read Access to the ECC Control and Status Registers

Read accesses to the ECC control and status registers for each ECC endpoint represent read operations over the ECC serial interface and are triggered by performing the following sequence:

- Software writes the following in the ECC_VECTOR register:
 - The ECC endpoint ID in the ECC_VECTOR[10-0] ECC_VECTOR field to select particular ECC endpoint.
 - The register read address in the ECC_VECTOR[23-16] RD_SVBUS_ADDRESS field to select which register has to be read through the ECC serial interface.
 - A value of 0x1 in the ECC_VECTOR[15] RD_SVBUS bit to trigger read operation through the ECC serial interface.
- Software polls the ECC_VECTOR[24] RD_SVBUS_DONE bit to check if it is 0x1. This indicates that the read operation on the ECC serial interface has completed.
- Software reads the data from the register previously selected by the ECC_VECTOR[23-16] RD_SVBUS_ADDRESS field.

The following is an example for serial read operation:

- Write 0x0010 8005 to the ECC_VECTOR register. This sends read request to the ECC_WRAP_REV or ECC_CBASS_REV register (address = 0x10) associated with ECC endpoint with ID = 5.
- Poll the ECC_VECTOR[24] RD_SVBUS_DONE bit until value of 0x1 is read.
- Read the ECC_WRAP_REV or ECC_CBASS_REV register to get its value.

13.6.2.3.4 Serial Write Operation

Write operations over the ECC serial interface are performed as follows:

- Software specifies the ECC endpoint ID in the ECC_VECTOR[10-0] ECC_VECTOR field. The ECC_VECTOR[23-16] RD_SVBUS_ADDRESS field is a don't care but the ECC_VECTOR[15] RD_SVBUS bit must be set to 0x0.
- Software performs regular write operation to the desired address. If the ECC endpoint ID has already been specified, step 1 can be skipped. Unlike serial read operations it is not necessary to always specify the endpoint ID before performing serial write operation.

The following is an example for serial write operation:

- Write 0x0000 0008 to the ECC_VECTOR register.
- Write 0x0000 000F to the ECC_CTRL register. This sends write request with data 0x0000 000F to the ECC_CTRL register associated with ECC RAM with ID = 8.

13.6.2.3.5 Interrupts

The ECC aggregator generates the following interrupts:

- Correctable interrupt (ECC_SEC_INT) where hardware can correct the error but notifies the system in case of SEC.
- Non-correctable interrupt (ECC_DED_INT) where hardware cannot correct the error in cases of DED, parity check, redundancy check or timeout occurrence.

The following is the sequence for servicing interrupts:

- Software enables the interrupts for an ECC endpoint by writing 0x1 to the corresponding bit of the following interrupt enable registers:
 - ECC_SEC_ENABLE_SET_REG0 through ECC_SEC_ENABLE_SET_REG7 for the correctable interrupt
 - ECC_DED_ENABLE_SET_REG0 through ECC_DED_ENABLE_SET_REG7 for the non-correctable interrupt
- On receiving an interrupt, software checks which ECC endpoint has caused the error by reading the following interrupt status registers:
 - ECC_SEC_STATUS_REG0 through ECC_SEC_STATUS_REG7 for the correctable interrupt
 - ECC_DED_STATUS_REG0 through ECC_DED_STATUS_REG7 for the non-correctable interrupt

- Software performs serial read operations as described in [Section 13.6.2.3.3](#) to read the following status registers that contain details about the error:
 - If the endpoint is ECC RAM:
 - ECC_ERR_STAT1
 - ECC_ERR_STAT2
 - ECC_ERR_STAT3
 - If the endpoint is interconnect ECC component:
 - ECC_CBASS_ERR_STAT1
 - ECC_CBASS_ERR_STAT2
- After the interrupt has been serviced, depending on the error type, software should clear the corresponding status bits in the ECC_ERR_STAT1 and ECC_ERR_STAT3 registers or in the ECC_CBASS_ERR_STAT1 register. Software has to poll these registers to guarantee that status bits are cleared as there is no other indication for write completion over the ECC serial interface.

The value of the *_PEND_CLR fields in the ECC_CBASS_ERR_STAT1 register must be read and then written back to decrement the count of each field back to 0x0. A further error capture into the ECC_CBASS_ERR_STAT1 register does not occur unless all its fields are 0x0. The decrement value should not be larger than the read value. If a field in the ECC_CBASS_ERR_STAT1 register should not be modified, write a value of 0x0 to that field.
- Software writes 0x1 to the corresponding end of interrupt register to clear the interrupt:
 - ECC_SEC_EOI_REG for the correctable interrupt
 - ECC_DED_EOI_REG for the non-correctable interrupt

13.6.2.3.6 Inject Only Mode

There are modules that already perform the ECC generation and checking as part of their data path. In this case, the ECC wrapper may be configured in inject only mode, if needed. In this mode the ECC wrapper does not perform ECC detection and correction. The inject only mode allows users to inject single or double-bit errors so that the module logic can be tested for diagnostic purposes.

Note

There is no software control to enable inject only mode. It is configured via tie-off value. Inject only and ECC modes are mutually exclusive.

The interconnect ECC component also supports error injection mode. There is error injection logic for testing of the error checking logic (checkers). The injection logic can be configured to inject either single or double bit error and what data pattern to be used for injection (ECC_CBASS_CTRL[11-8] ECC_PATTERN). The ECC_CBASS_ERR_CTRL1 and ECC_CBASS_ERR_CTRL2 registers should be written first to setup the injection. Then, either the ECC_CBASS_CTRL[3] FORCE_SE or the ECC_CBASS_CTRL[4] FORCE_DE bit must be set to 0x1 to start the injection. Both bits must not be set at the same time. If the injection should continue in incrementing mode, then the ECC_CBASS_CTRL[5] FORCE_N_BIT bit should be set to 0x1. Once the FORCE_N_BIT is set, then each successive injection can simply write the ECC_CBASS_CTRL register to set the FORCE_SE or FORCE_DE again. Reading 0x0 from either the FORCE_SE or the FORCE_DE bit indicates that the injection has completed, as these bits automatically clear when the checker indicates that it has performed the injection. The time for an injection to complete is not guaranteed, so some delay is needed between successive injections.

13.6.3 Error Signaling Module (ESM)

This section describes the Error Signaling Module (ESM) in the device.

13.6.3.1 ESM Overview

The Error Signaling Module (ESM) aggregates events and/or errors from throughout the device into one location. It can signal both low and high priority interrupts to a processor to deal with an event and/or manipulate an I/O error pin to signal an external hardware that an error has occurred. Therefore an external controller is able to reset the device or keep the system in a safe, known state.

shows ESM allocation across .

[Figure 13-288](#) shows the ESM modules overview.

A. $i = 0$

Figure 13-288. ESM Modules Overview

13.6.3.1.1 ESM Features

Each ESM module implements the following features:

- Up to 1024 error event inputs
 - Implemented in groups of 32 events
 - Level or Pulse inputs (Pulse inputs are triple redundant)
- Selectable low and high priority interrupt error pin prioritization of each error event
- Error pin to signal severe device failure
 - Support of level or PWM modes
- Configurable timebase for error signal
- Error forcing capability
- Internal redundant flops on critical fields

13.6.3.2 ESM Environment

The ESM0 modules are hereinafter referred to as *ESM* module.

This section describes the ESM external connections (environment).

Table 13-303. ESM I/O Signals

Module Pin	Device Level Signal	I/O ⁽¹⁾	Description	Module Pin Reset Value ⁽²⁾
MCU_ESM0				
ESM_ERR_O ⁽³⁾	SAFETY_ERRORn	O	SoC ESM Error output signal (Active Low)	0 ⁽²⁾

- (1) O = Output;
- (2) During POR, the pin state is weak pull-down and the I/O is under the control of the device. Once PORz are de-asserted, SAFETY_ERRORn will be driven by the ESM module.
- (3) The ERR_O output of ESM0 drives the SAFETY_ERRORn pin.

Note

For more information about device level signals (pull-up/down resistors, buffer type, multiplexing and others), see tables *Pin Attributes* and *Pin Multiplexing* in the device-specific Datasheet.

13.6.3.3 ESM Integration

This section describes the ESM integration in the device, including information about clocks, resets, and hardware requests.

13.6.3.3.1 ESM Integration

There is 1x ESM integrated in the device. The diagram below provides a visual representation of the device integration details.

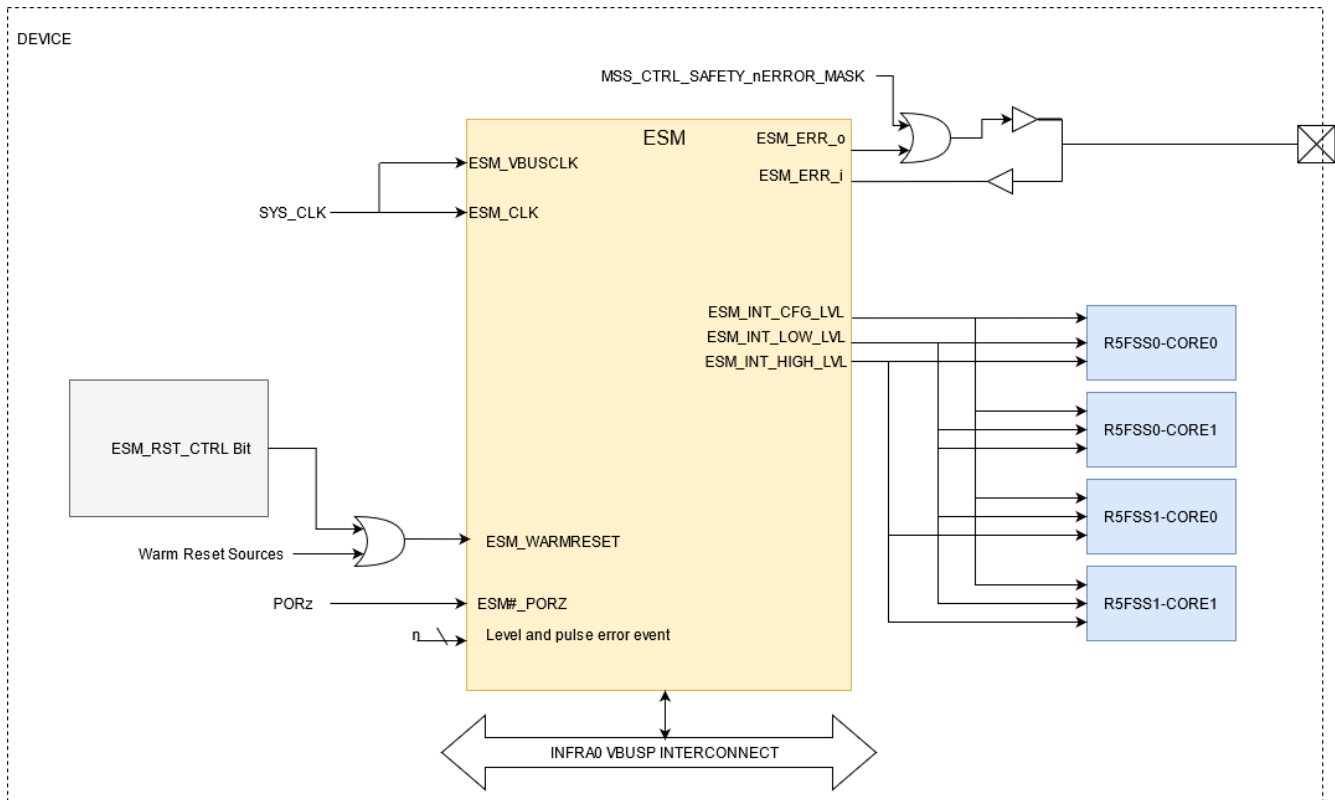

Figure 13-289. ESM Integration Diagram

The tables below summarize the device integration details of ESM.

Table 13-304. ESMDevice Integration

This table describes the ESM device integration details.

ESM Instance	Device Allocation	SoC Interconnect
ESM0	✓	INFRA0 VBUSP Interconnect

Table 13-305. ESMClocks

This table describes the ESM clocking signals.

ESM Instance	ESM Clock Input	Source Clock Signal	Source	Default Freq	Description
ESM0	ESM0_VBUSCLK	SYS_CLK	PLL_CORE_CLK: HSDIV0_CLKOUT0	200 MHz	ESM0 VBUSP Interface Clock
	ESM0_CLK				ESM0 Functional Clock

Table 13-306. ESM Resets

This table describes the ESM reset signals.

ESM Instance	ESM Reset Input	Source Reset Signal	Source	Description
ESM0	ESM0_RST	Warm Reset (MOD_G_RST)	RCM + Warm Reset Sources	ESM0 Asynchronous Reset
	ESM0_POR_RST	POR Reset (MOD_POR_RST)	Device Power-On Reset	ESM0 Power-On Reset

Table 13-307. ESM Interrupt Requests

This table describes the ESM interrupt requests.

ESM Instance	ESM Interrupt Signal	Destination Interrupt Input	Destination	Type	Description
ESM0	ESM0_INT_CFG_LVL_0	ESM0_INT_CFG_LVL	ALL R5FSS Cores	Level	ESM0 Configuration Error Interrupt
	ESM0_INT_LOW_LVL_0	ESM0_INT_LOW_LVL			ESM0 Low Priority Interrupt
	ESM0_INT_HIGH_LVL_0	ESM0_INT_HIGH_LVL			ESM0 High Priority Interrupt

Note

For more information on the interconnects, see the *System Interconnect* chapter.

For more information on power, reset, and clock management, see the corresponding sections within the *Device Configuration* chapter.

For more information on the device interrupt controllers, see the *Interrupt Controllers* chapter.

13.6.3.4 ESM Functional Description

The Error Signaling Module (ESM) centralizes fault reports. The module provides mechanisms to classify errors by severity and to provide programmable error response. The error classification in the ESM is determined by programmed configuration for each individual error input. For each individual error input the configuration can be set to assert an output error pin, or generate an interrupt to a CPU, or both. When an individual error input is configured to generate an interrupt, the configuration also selects whether the interrupt that is generated is high priority or low priority.

By reporting the faults in a central location, the system can determine what caused the fault and what action can be taken. In general, the faults can be split into two categories:

- Corrected faults
- Non-corrected faults

The ESM reports errors in two ways:

- An interrupt to a processor in the device. This allows the device to analyze and try to recover from an error.
- An external ERROR pin. This allows the system outside of the SoC to monitor for potentially fatal errors (errors that the device cannot self-recover from). Moreover, the external I/O (ERROR pin) can operate in level or PWM modes. In level mode, the output remains asserted (active low) for a minimum period of time. After that period of time, if the error has been cleared by an internal processor, the pin goes inactive (high). If signal does not go inactive in that time, then an external agent must intervene, as an unrecoverable error can occur. In PWM mode, the error causes the output pin to maintain the value for a minimum period of time. After that period of time, if the error has been cleared by an internal processor, the pin continues the PWM pattern. If the signal does not go inactive in that time, then an external agent must intervene, as an unrecoverable error can occur.

Both mechanisms can be used at the same time for the same fault, signaling both an interrupt and the external ERROR pin. This allows the device to attempt to recover, but if recovery fails, then the external system is still alerted. If recovery succeeds, then the ERROR pin assertion can be removed so that the external system knows that a potentially unsafe condition was avoided.

Lastly, the ESM does not specify any methods of intervention, only the process of alerting internal CPUs and external monitors of an existing error event.

[Figure 13-290](#) shows the ESM module block diagram. For more information, see [Section 13.6.3.2, ESM Environment](#).

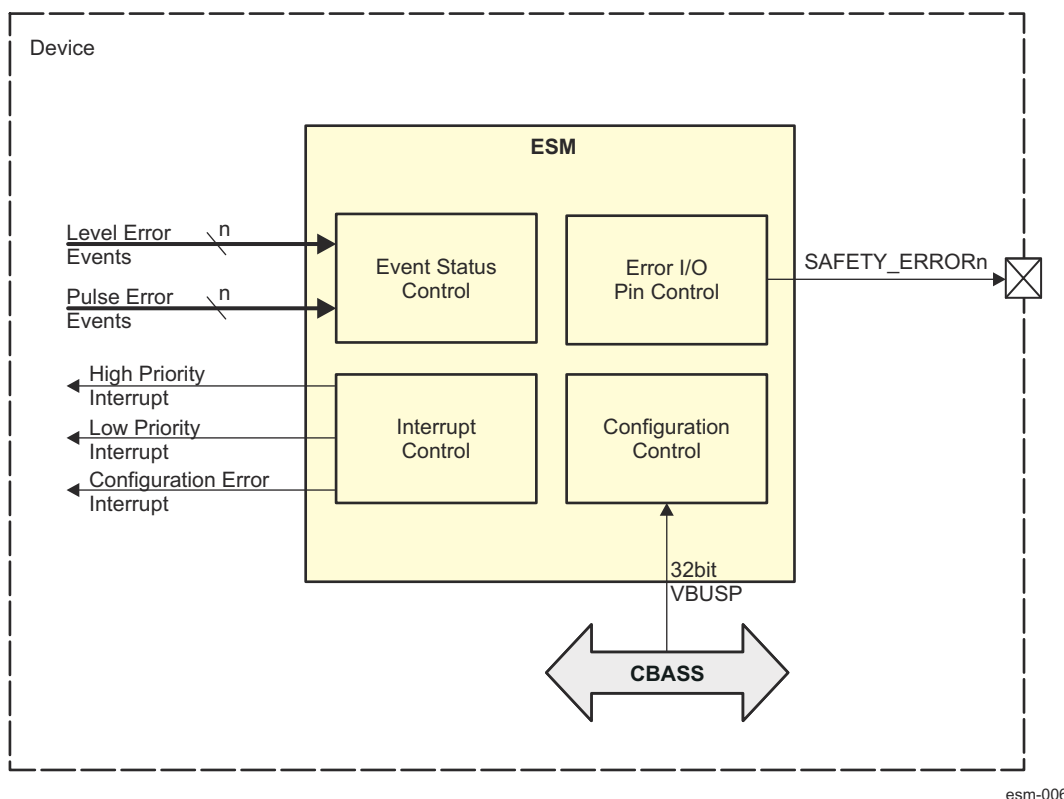
Figure 13-290. ESM Block Diagram

13.6.3.4.1 ESM Interrupt Requests

The ESM module generates three output interrupts to the device interrupt controllers:

- Configuration error interrupt (see [Section 13.6.3.4.1.1](#))
- High priority error interrupt (see [Section 13.6.3.4.1.2](#))
- Low priority error interrupt (see [Section 13.6.3.4.1.3](#))

The error interrupt outputs are provided so that a processor in the device can be signaled to intervene when an error event occurs. Each error event input can be enabled, via software, to cause an error interrupt to occur (via the ESM_INTR_EN_SET_j register). Additionally, each error event input can be programmed to influence either the low priority (default) interrupt or the high priority interrupt (via the ESM_INT_PRIO_j). The low priority interrupt is intended for events that are of interest, but do not require immediate intervention. For example, an indication that there was a single bit error that was corrected may signal a low priority interrupt, so that information can be collected for statistical purposes. A high priority interrupt is intended for events that need immediate attention. For example, an indication that there was an uncorrected two-bit error may be signaled as a high priority interrupt.

13.6.3.4.1.1 ESM Configuration Error Interrupt

The configuration error interrupt (ESM_INT_CFG_LVL_0) indicates that there is an inconsistency in the configuration of one (or more) error group *j* registers (MMRs).

In such inconsistency in the internal copies of any of the MMRs caused by fault associated with error group *j*, the corresponding raw status will be set in the ESM_ERR_RAW register. If the corresponding bit is enabled in the ESM_ERR_EN_SET register, a configuration error interrupt will be triggered.

When a configuration error interrupt is received, the acting processor must perform the following steps:

1. Read the ESM_ERR_STS register to determine which group has a configuration error
2. Write the correct values to the following group registers:

Note

If there has been a configuration error, the values in the below registers cannot be guaranteed to be correct anymore. Therefore, software should maintain a copy of the correct values prior to an error to ensure that they can be re-programmed with the correct configuration.

- a. ESM_INTR_EN_SET_j
 - b. ESM_INTR_EN_CLR_j
 - c. ESM_INT_PRIO_j
 - d. ESM_PIN_EN_SET_j
 - e. ESM_PIN_EN_CLR_j
3. Service any pending interrupts in steps 4, 5, and 6 below
-

Note

The raw status of any pending interrupts may be inconsistent. Servicing the interrupt will return it to consistency via the error group ESM_RAW_j register. The raw interrupt status registers should also be cleared before enabling ESM or the ESM will generate an interrupt to CPU.

4. Write 0x1 to the appropriate bits in the ESM_ERR_STS register. This step will clear the raw status
 - a. If the error event is still asserted (or re-asserted) the raw status will be set back to 0x1
 - b. If there are no additional errors, the level interrupt will go low
5. Write the end of interrupt vector to the ESM_EOI register
 - a. If there are additional configuration error interrupts pending, then a new pulse will be generated and the level interrupt will remain asserted
 - b. If there are no additional low priority error interrupts pending, there will be no new pulse.

13.6.3.4.1.2 ESM Low Priority Error Interrupt

Events mapped to the low priority error interrupt (ESM_INT_LOW_LVL_0) are intended to be events of interest that should be addressed eventually, not events that require immediate attention. An example would be an event indicating a corrected error. The system may want to track this for statistical purposes, but it does not require immediate attention.

Any error event can be mapped to the low priority error interrupt. A low priority error interrupt will be generated when an event is enabled to cause an interrupt (via the ESM_INTR_EN_SET_j register) and mapped to the low priority error interrupt (via ESM_INT_PRIO_j register) and the raw status is set (via the ESM_RAW_j register).

When a low priority error interrupt is received, the acting processor must perform the following steps:

1. Read the ESM_LOW_PRI register
 - a. If both [31-16]PLS and [15-0]LVL bit fields are equal to 0xFFFF, then interrupt is no longer asserted and the interrupt routine has ended.
 - b. If either [31-16]PLS or [15-0]LVL bit fields are not equal to 0xFFFF, software has two options for determining what event to service:
 - i. First option: Record the value in [31-16]PLS and [15-0]LVL bit fields. Determine which is higher priority. This is based on the global event map number of the highest priority low priority error event
-

Note

The global event map is neither defined by nor maintain in ESM. The global event map must be defined and maintained by software using software determined memory resources. It is conceivable that the global event map will be predefined and loaded during the execution of a secondary boot loader.

- ii. Second option:
 1. Read the ESM_LOW register to determine which event group(s) have pending low priority error interrupts
 2. Read the desired error group j ESM_STS_j register
 3. Identify which low priority interrupt to service

2. Determine, based on the global event map for the device, where the error event came from
3. Service the error event based on the IP's specification:
 - a. The system may take several actions including (but not limited to):
 - i. Fixing the error
 - ii. Resetting the errored IP peripheral
 - iii. Resetting the device
 - iv. Communicating outside the device via the error pin for outside intervention

The rest of the steps assume that the error has been handled and the system wants to clear the error event. Clearing the error event depends on whether the event is a level (see [Section 13.6.3.4.1.2.1](#)) or pulse (see [Section 13.6.3.4.1.2.2](#)) event.

13.6.3.4.1.2.1 ESM Low Priority Error Level Event

When a low priority error level event has to be cleared, the acting processor must perform the following steps:

1. Clear the low priority error level event at the source
2. Write 0x1 to the appropriate bit in the error group j of the ESM_STS_ j register. This step will clear the raw status
 - a. If the error event is still asserted (or re-asserted) the raw status will be set back to 0x1
 - b. If there are no error events, the level will de-assert

Note

There is a possible software race condition if software manages to write to the Clear register before the de-asserted level from the source has been synchronized to the ESM clock. If this is an issue, software may perform a read-back at the source IP before writing the clear register to insure order.

3. Write the end of interrupt vector to the ESM_EOI interrupt register
 - a. If there are low priority error level events enabled and pending, then a new pulse will be generated
 - b. If there are no additional low priority error level events enabled and pending, there will be no new pulse
4. Write a CLEAR (0x5) to the ESM_PIN_CTRL register. This step is optional if the event is not enabled to influence the error pin (error group j ESM_PIN_EN_SET_ j register), but may be done regardless as an extra CLEAR is not harmful.

13.6.3.4.1.2.2 ESM Low Priority Error Pulse Event

When a low priority error pulse event has to be cleared, the acting processor must perform the following steps:

1. Write 0x1 to the appropriate bit in the error group j of the ESM_STS_ j register. This will clear the raw status and will de-assert the level interrupt.
2. Write the end of interrupt vector to the ESM_EOI interrupt register
 - a. If there are additional low priority error pulse events enabled and pending, then a new pulse will be generated and the level interrupt will remain asserted
 - b. If there are no additional low priority error pulse events enabled and pending, there will be no new pulse
3. Clear the error event at the source. The source may generate a new pulse which will show up as a new error event at the ESM
4. Write a CLEAR (0x5) to the ESM_PIN_CTRL register. This step is optional if the event is not enabled to influence the error pin (error group j ESM_PIN_EN_SET_ j register), but may be done regardless as an extra CLEAR is not harmful.

13.6.3.4.1.3 ESM High Priority Error Interrupt

Events mapped to the high priority error interrupt are intended to be events that require immediate intervention from the system because a potentially dangerous error has occurred. An example would be an event indicating an uncorrected error. The system will want to diagnose the issue and intervene to ensure there are no violations.

Any error event can be mapped to the high priority error interrupt. A high priority error interrupt will be generated when an event is enabled to cause an interrupt (via the ESM_INTR_EN_SET_ j) register and mapped to the high priority interrupt (via the ESM_INT_PRIO_ j) register and the raw status is set (via the ESM_RAW_ j).

When a high priority error interrupt is received, the acting processor must perform the following steps:

1. Read the ESM_HI_PRI register
 - a. If both [31-16] PLS and [15-0] LVL bit fields are equal to 0xFFFF, then interrupt is no longer asserted and the interrupt routine has ended.
 - b. If either [31-16] PLS or [15-0] LVL bit fields are not equal to 0xFFFF, software has two options for determining what event to service:
 - i. First option: Record the value in [31-16] PLS and [15-0] LVL bit fields. Determine which is higher priority. This is based on the global event map number of the highest priority high priority error event.

Note

The global event map is neither defined by nor maintain in ESM. The global event map must be defined and maintained by software using software determined memory resources. It is conceivable that the global event map will be predefined and loaded during the execution of a secondary boot loader.

- ii. Second option:
 1. Read the ESM_HI register to determine which event group(s) have pending high priority error interrupts
 2. Read the desired error group *j* ESM_STS_ *j* register
 3. Identify which high priority error interrupt to service
2. Determine, based on the global event map for the device, where the error event came from
3. Service the error event based on the IP's specification:
 - a. The system may take several actions including (but not limited to):
 - i. Fixing the error
 - ii. Resetting the errored IP peripheral
 - iii. Resetting the device
 - iv. Communicating outside the device via the error pin for outside intervention

The rest of the steps assume that the error has been handled and the system wants to clear the error event. Clearing the error event depends on whether the event is a level (see [Section 13.6.3.4.1.3.1](#)) or pulse (see [Section 13.6.3.4.1.3.2](#)) event.

13.6.3.4.1.3.1 ESM High Priority Error Level Event

When a high priority error level event has to be cleared, the acting processor must perform the following steps:

1. Clear the error event at the source
2. Write 0x1 to the appropriate bit in the error group *j* of the ESM_STS_ *j* register. This step will clear the raw status
 - a. If the error event is still asserted (or re-asserted) the raw status will be set back to 0x1
 - b. If there are no error events, the level will de-assert

Note

There is a possible software race condition if software manages to write to the Clear register before the de-asserted level from the source has been synchronized to the ESM clock. If this is an issue, software may perform a read-back at the source IP before writing the clear register to insure order.

3. Write the end of interrupt vector to the ESM_EOI interrupt register
 - a. If there are high priority error level events enabled and pending, then a new pulse will be generated
 - b. If there are no additional high priority error level events enabled and pending, there will be no new pulse
4. Write a CLEAR (0x5) to the ESM_PIN_CTRL register. This step is optional if the event is not enabled to influence the error pin (error group *j* ESM_PIN_EN_SET_ *j* register, but may be done regardless as an extra CLEAR is not harmful.

13.6.3.4.1.3.2 ESM High Priority Error Pulse Event

When a high priority error pulse event has to be cleared, the acting processor must perform the following steps:

1. Write 0x1 to the appropriate bit in the error group j of the ESM_STS_ j register. This will clear the raw status and will de-assert the level interrupt.
2. Write the end of interrupt vector to the ESM_EOI interrupt register
 - a. If there are high priority error pulse events enabled and pending, then a new pulse will be generated and the level interrupt will remain asserted
 - b. If there are no additional high priority error pulse events enabled and pending, there will be no new pulse
3. Clear the error event at the source. The source may generate a new pulse which will show up as a new error event at the ESM
4. Write a CLEAR (0x5) to the ESM_PIN_CTRL register. This step is optional if the event is not enabled to influence the error pin (error group j ESM_PIN_EN_SET_ j register), but may be done regardless as an extra CLEAR is not harmful.

13.6.3.4.2 ESM Error Event Inputs

The ESM can have up to 1024 error event inputs, configurable by groups of 32. For the mapping of system interrupt error events to ESM interrupt inputs, see , *Interrupt Sources*.

Level error events (active high) are synchronized to the ESM clock. This synchronized value is captured in to a flop.

Pulse error events use rising edge detection. Each pulse error event has 3 redundant inputs. Each input has its own edge detection logic. Multiple transmission protects against Single Event Upsets (SEUs, transient errors) causing a pulse to be lost during transmission and against failure of the edge detection logic. Once an edge has been detected on any of the three inputs, the ESM_RAW_ j status is set. Subsequent pulses are likely to come concurrently or quickly enough that software will not have reacted yet. This logic is intentionally biased against false negatives and towards false positives. An SEU that causes an event where none actually occurred will cause software to be called in to action. Software must observe that there is no real error and clear the false status.

13.6.3.4.3 ESM Error Pin Output

The error pin output (ERR_O) is used to signal an external agent that it needs to (or may need to) intervene because of an error. Each error event input can be programmed, via software, to influence the error pin output (via the ESM_PIN_EN_SET_ j register). The error pin output is active low or PWM based on the ESM_EN[7-4] PWM_EN field. This bit field should only be modified when the ESM is disabled, based on the ESM_EN register.

During Power-On Reset (POR), the error pin is active (asserted low) and the device drives this via a weak internal pull-down. The I/O is under the control of the device. When POR is removed from the ESM, it will be driving the error pin so the device can hand over control to the ESM. The user may also add an external pull-down that is only active when the device is in reset.

During a warm reset the state of the error pin is unchanged, that is the error pin logic is only reset by a POR. The device leaves the I/O active during a warm reset.

The ESM has also a software error forcing capability on the error pin. That is, a force error can be set via the ESM_EN[3-0] KEY bit field.

CAUTION

The isolation value for the ERR_O output of ESM is active (0). This is intended and supposed to protect against an accidental transition to a low power state. If the actual low power mode transition is intended, the PMIC should be made aware by software to ignore the ESM error signal. Otherwise device resets will be asserted from companion chip.

Figure 13-291 describes the behavior of the error pin. Not shown is that a reset (Power-On-Reset only) will immediately transition the error pin to the ESM_RESET state and a Global Soft Reset will immediately transition the error pin to the ESM_IDLE state. A pending error interrupt event is any error event with the raw state set and the error pin Influence enabled. There are two types of "clear" events associated with servicing the error pin. The first is to clear the status of the pending event (see Section 13.6.3.4.1 for how to clear level and pulse pending events). The second is the CLEAR event meant to de-assert the error pin.

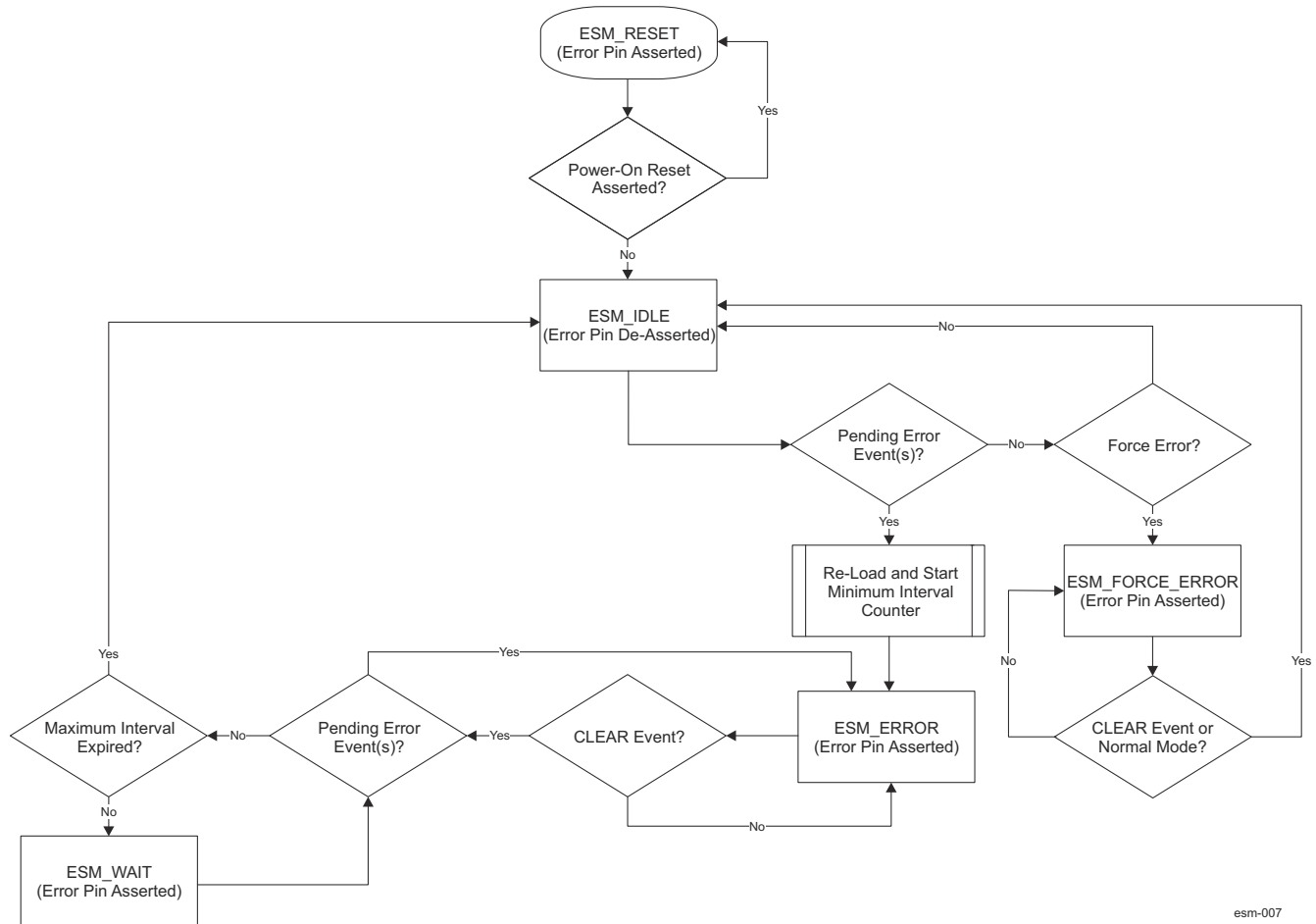

Figure 13-291. ESM Error Pin State Flowchart

If an error event happens that has been programmed to influence the error pin, the error pin will assert (active low) for a minimum time (as programmed by the ESM_PIN_CNTR_PRE register). In order for the error pin to de-assert, the following 3 things must happen:

1. The minimum time interval must expire
2. The event that caused the error pin to assert must be cleared (see Section 13.6.3.4.1)
3. A CLEAR (0x5) must be written to the ESM_PIN_CTRL register.

Note

Step 3 should happen after step 2, but either (or both) of these steps may happen before or after step 1.

Figure 13-292 shows a typical error pin assertion.

esm-007

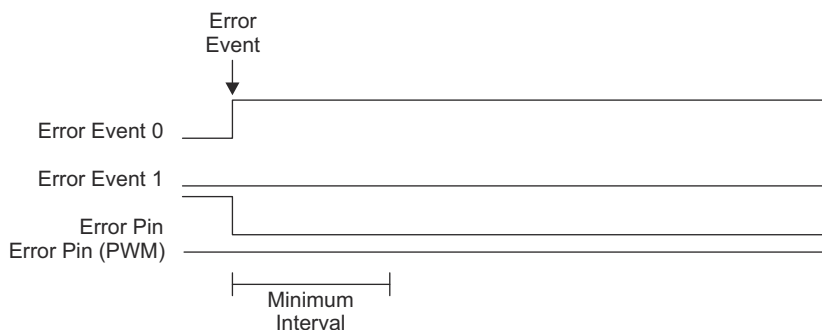

esm-008

Figure 13-292. ESM Error Pin Assertion

If, during the minimum time, CLEAR is written to the error key, then the error pin will de-assert after the minimum time interval, as shown in Figure 13-293.

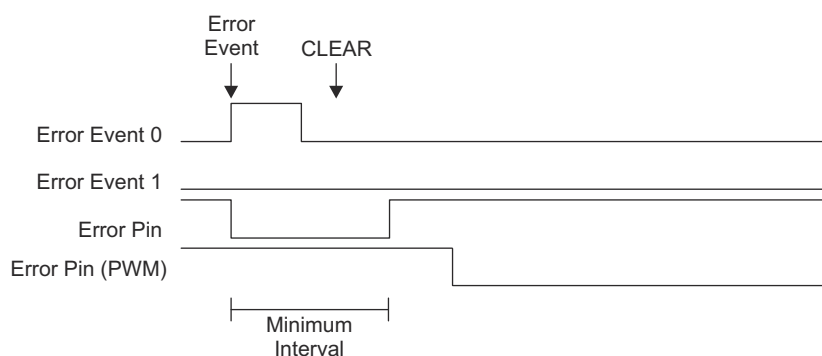

esm-009

Figure 13-293. ESM Error Pin Assertion with CLEAR during Minimum Interval

If CLEAR is not written till after the minimum time interval, the error pin will de-assert when CLEAR is written. This is regardless of whether the error interrupt event itself is removed before or after the minimum time interval, as shown by the dotted line in Figure 13-294.

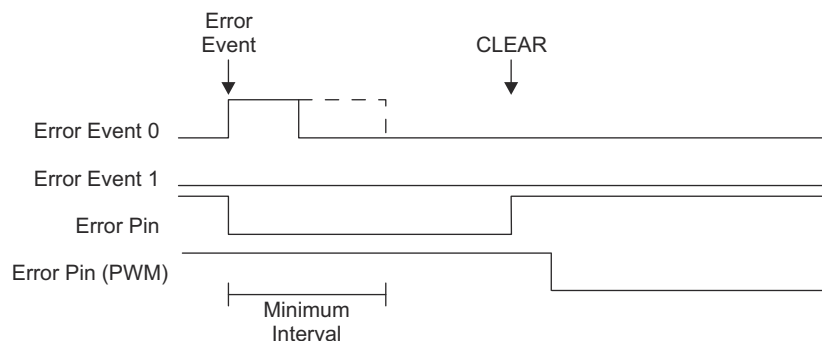

esm-010

Figure 13-294. ESM Error Pin Asserting with CLEAR after Minimum Interval

When in the ESM_ERROR state and a CLEAR event happen, if there are still pending error events, the ESM stays in the ESM_ERROR state with the error pin asserted. Multiple error events when in the ESM_ERROR state do not reset the minimum time interval counter as shown in Figure 13-295.

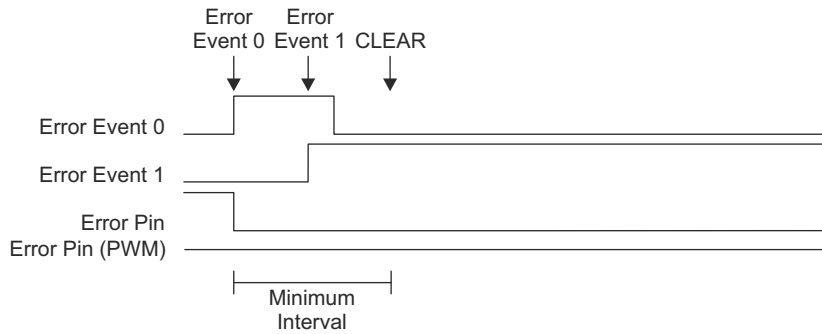

esm-011

Figure 13-295. ESM Error Pin Asserting with Interval Reset by Additional Error Event(s)

A CLEAR event causes a re-evaluation of whether there are any pending error events. As such, a single CLEAR can be used to clear the error pin after multiple error events. Multiple CLEAR events can occur (such as the one with the dotted arrow shown in Figure 13-296), but are not necessary. No matter how many error events occur nor when (or how many) CLEAR events occur, the error pin will always be asserted for at least the minimum time interval

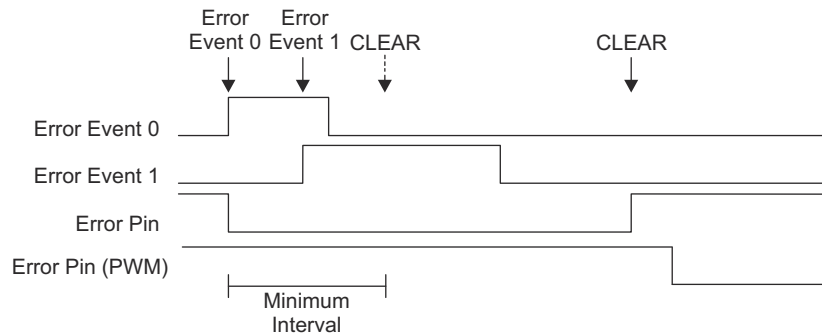

esm-012

Figure 13-296. ESM Error Pin Asserting with Single CLEAR for Multiple Events

If all error events are cleared and the ESM is in the ESM_WAIT state, waiting for the minimum time interval to expire, and a new error interrupt event occurs, the ESM will go back to the ESM_ERROR state. The minimum time interval will not reset, but a new CLEAR event will be required as shown in Figure 13-297.

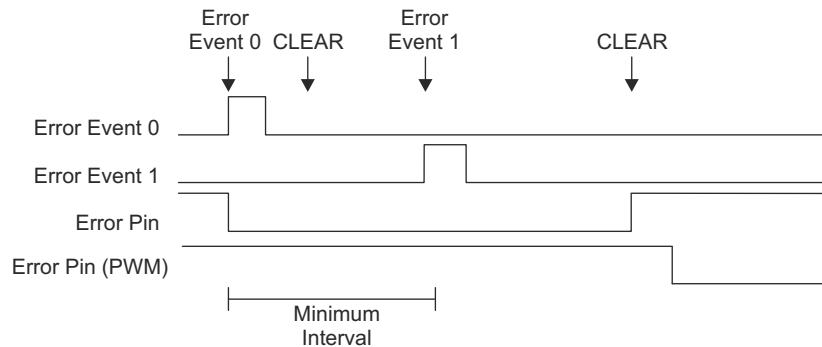

esm-013

Figure 13-297. ESM Error Pin Asserting with New Error During Minimum Time Interval

Table 13-308 shows some common scenarios of how the error pin as well as the two associated registers (ESM_PIN_CTRL and ESM_PIN_STS) will be set.

Table 13-308. ESM Error Pin Scenarios

Scenario	Error Pin State Value	ESM_PIN_CTRL[3-0] KEY	ESM_PIN_STS[0] VAL status value	Additional Notes
POR Asserted	0	N/A	N/A	Registers are inaccessible. Device disables the I/O and pulls down internally.
After de-assertion of POR	1	0x0 (Normal Mode)	0x0	-
After de-assertion of Warm Reset (error was not asserted when reset asserted)	1	0x0 (Normal Mode)	0x0	-
After de-assertion of Warm Reset (error was asserted when reset asserted)	0	0x0 (Normal Mode)	0x1	-
Force error pin	0	0xA (Force Error Mode)	0x0	Forcing error on the pin via software.

13.6.3.4.4 PWM Mode

If the error output pin is in PWM mode then when no error is detected it will toggle according to programmable MMR widths for high and low periods. When an error occurs, the error pin stops toggling and remains constant until the error is cleared. An external PMIC that is detecting the PWM toggles can identify the error if the pin stops toggling. The periods should be programmed such that they fit within the expectation of the external PMIC.

13.6.3.4.5 ESM Minimum Time Interval

The minimum time interval is the minimum amount of time that the error pin will be asserted (active low) when an enabled error interrupt event happens. This value is system dependent, but should be enough time so that the external monitoring agent can always see the error pin asserted, but short enough so that if all of the error events are cleared, then the error pin can be de-asserted before the external agent decides to intervene. This is highly dependent on the application and the Fault Tolerant Time Interval.

The Minimum Time Interval counter is clock cycle based, therefore the time of the interval is a combination of the value in the ESM_PIN_CNTR_PRE register and the clock frequency of the ESM. Software must calculate the value accordingly. The Minimum Time Interval should be set according to the needs of the application.

13.6.3.4.6 ESM Protection for Registers

The configuration for each error group j of registers are backed up by 3 flops in order to protect against single or double-bit errors. When written, all 3 bits are set to the same value. When read (and for functioning of the internal state machines) the value is the OR of all 3 bits. Whenever any of the bits disagree, the Configuration Error interrupt is asserted (if enabled). The registers covered by this mechanism are:

- ESM_ERR_RAW
- ESM_ERR_STS
- ESM_ERR_EN_SET
- ESM_ERR_EN_CLR
- ESM_RAW_j
- ESM_STS_j
- ESM_INTR_EN_SET_j
- ESM_INTR_EN_CLR_j
- ESM_INT_PRIO_j
- ESM_PIN_EN_SET_j
- ESM_PIN_EN_CLR_j

The error pin control register ESM_PIN_CTRL contains a multi-bit field KEY. The key value ensures normal operation on the error pin and that an error even will be generated if one occurs. Software should periodically read check the KEY bit field value and make sure it is 0x0. If the value is not 0x0, software must re-write it to this key value (unless in test mode forcing an error on the pin) to ensure the normal operation. [Table 13-309](#) lists the KEY values and their respective meaning.

Table 13-309. ESM Error Pin Control Values

ESM_PIN_CTRL[3-0] KEY	Description
N/A	Registers are inaccessible. Device disables the I/O and pulls down internally.
0x0 (Normal)	Normal operation mode - Error pin will activate when an enabled error event occurs.
0xA (Force Error)	Force error mode - Forces the error pin active. To clear the error pin (return to the ESM_IDLE state) write this field back to normal mode (writing a CLEAR event will also work). Force error mode must be set only while in IDLE. Attempting force error while in another state will have no effect.
0x5 (CLEAR)	CLEAR Event - generates a CLEAR event to the ESM state machine. KEY will return to normal mode (0x0) on the next cycle.
Other Values	All other values - Normal mode. Writing any of these values will have no effect. When reading any of these values indicates that one or more bits have experienced a single event upset, software should write the field back to 0x0. The ESM will continue to operate in normal mode.

The error pin counter pre-load register ESM_PIN_CNTR_PRE should also be read and checked periodically by software.

13.6.3.4.7 ESM Clock Stop

The ESM can only be put in to clock stop if all of the internal state machines are idle and the [3-0] KEY bit field for the global enable command is cleared in the ESM_EN register.

13.6.4 Memory Cyclic Redundancy Check (MCRC) Controller

This chapter describes the Memory Cyclic Redundancy Check (MCRC) controller in the device.

13.6.4.1 MCRC Overview

VBUSM CRC controller is a module which is used to perform CRC (Cyclic Redundancy Check) to verify the integrity of a memory system. A signature representing the contents of the memory is obtained when the contents of the memory are read into MCRC Controller. The responsibility of MCRC controller is to calculate the signature for a set of data and then compare the calculated signature value against a pre-determined good signature value. MCRC controller provides four channels to perform CRC calculation on multiple memories in parallel and can be used on any memory system.

13.6.4.1.1 MCRC Features

MCRC has the following features:

- Four channels to perform background signature verification on any memory subsystem
- Data compression on 8-, 16-, 32-, and 64-bit data size
- Maximum-length PSA (Parallel Signature Analysis) register constructed based on 64-bit primitive polynomial
- Each channel has a CRC Value Register which contains the pre-determined CRC value
- Use timed base event trigger from timer to initiate DMA data transfer
- Programmable 20-bit pattern counter per channel to count the number of data patterns for compression
- Three modes of operation:
 - Auto
 - Semi-CPU
 - Full-CPU
- For each channel, CRC can be performed either by MCRC Controller or by CPU
- Automatically performs signature verification without CPU intervention in AUTO mode
- Generates interrupt to CPU in Semi-CPU mode to allow CPU to perform signature verification itself
- Generates CRC fail interrupt in AUTO mode if signature verification fails
- Generates Timeout interrupt if CRC is not performed within the time limit
- Generates DMA request per channel to initiate CRC value transfer

13.6.4.1.2 MCRC Not Supported Features

The following features are not supported by the module:

- Data trace capability on VBUSM, ITCM and DTCM data buses.
- Auto Mode.

13.6.4.2 MCRC Integration

There is 1x MCRC integrated in the device. The diagram below provides a visual representation of the device integration details.

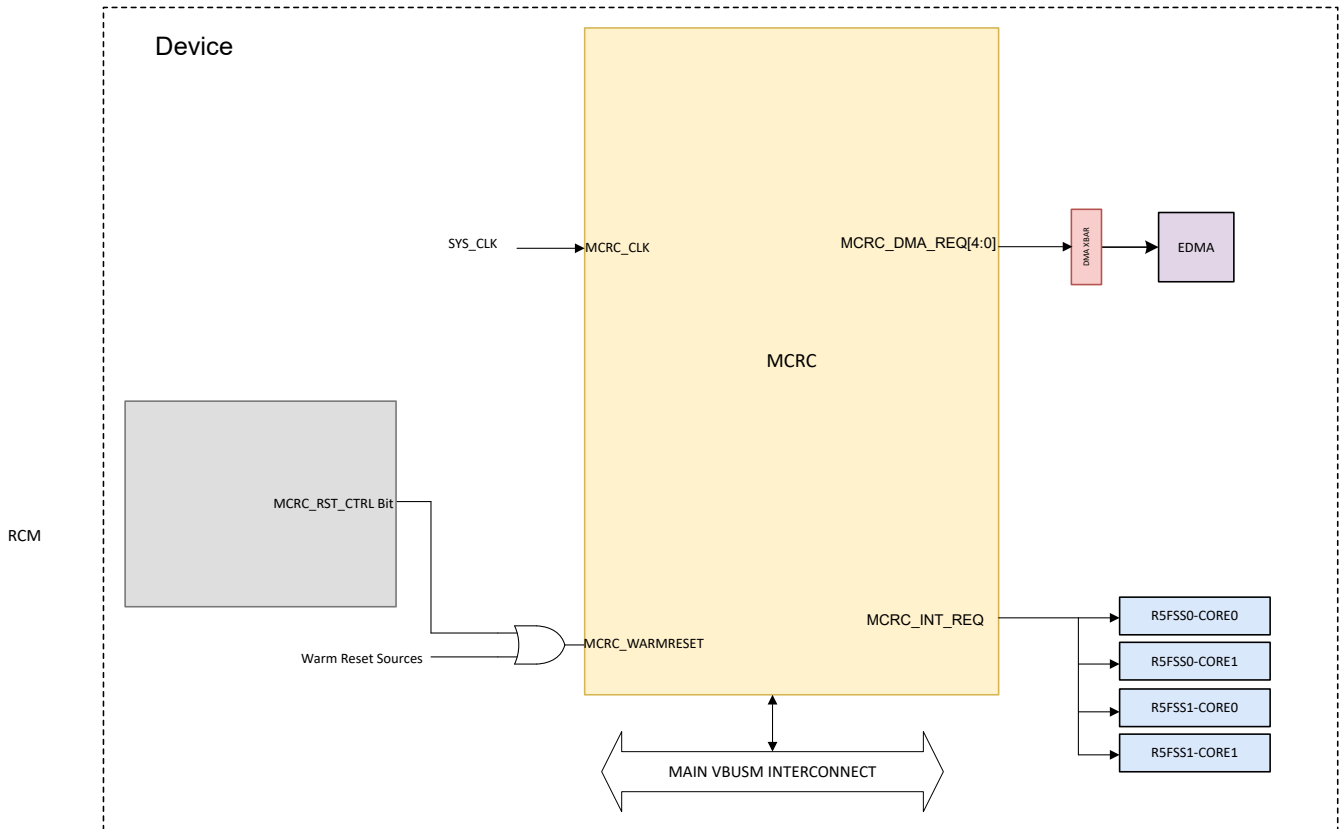

Figure 13-298. MCRC Integration

The tables below summarize the device integration details of MCRC# (where # = 1).

Table 13-310. MCRC Device Integration

This table describes the MCRC device integration details.

MCRC Instance	Device Allocation	SoC Interconnect
MCRC0	✓	CORE VBUSM Interconnect

Table 13-311. MCRC Clocks

This table describes the MCRC clocking signals.

MCRC Instance	MCRC Clock Input	Source Clock Signal	Source	Default Freq	Description
MCRC0	MCRC_CLK	SYS_CLK	PLL_CORE_CLK: HSDIV0_CLKOUT0	200 MHz	MCRC0 Interface Clock

Table 13-312. MCRC Resets

This table describes the MCRC reset signals.

MCRC Instance	MCRC Reset Input	Source Reset Signal	Source	Description
MCRC0	MCRC0_RST	Warm Reset (MOD_G_RST)	RCM + Warm Reset Sources	MCRC0 Asynchronous Reset

Table 13-313. MCRC Interrupt Requests

This table describes the MCRC interrupt requests.

MCRC Instance	MCRC Interrupt Signal	Destination Interrupt Input	Destination	Type	Description
MCRC0	MCRC0_INT_req	MCRC0_INT_req	ALL R5FSS Cores	Level	MCRC0 Event Interrupt

Table 13-314. MCRC DMA Requests

This table describes the MCRC DMA requests.

MCRC Instance	MCRC DMA Event	Destination DMA Event Input	Destination	Type	Description
MCRC0	MCRC0_DMA_0	MCRC0_dma_req[0]	EDMA Crossbar (DMA_XBAR)	Pulse	MCRC0 DMA Request
	MCRC0_DMA_1	MCRC0_dma_req[1]			
	MCRC0_DMA_2	MCRC0_dma_req[2]			
	MCRC0_DMA_3	MCRC0_dma_req[3]			

Note

For more information on the interconnects, see the *System Interconnect* chapter.

For more information on power, reset, and clock management, see the corresponding sections within the *Device Configuration* chapter.

For more information on the device interrupt controllers, see the *Interrupt Controllers* chapter.

13.6.4.3 MCRC Functional Description

13.6.4.3.1 MCRC Block Diagram

Figure 13-299 shows the MCRC internal blocks.

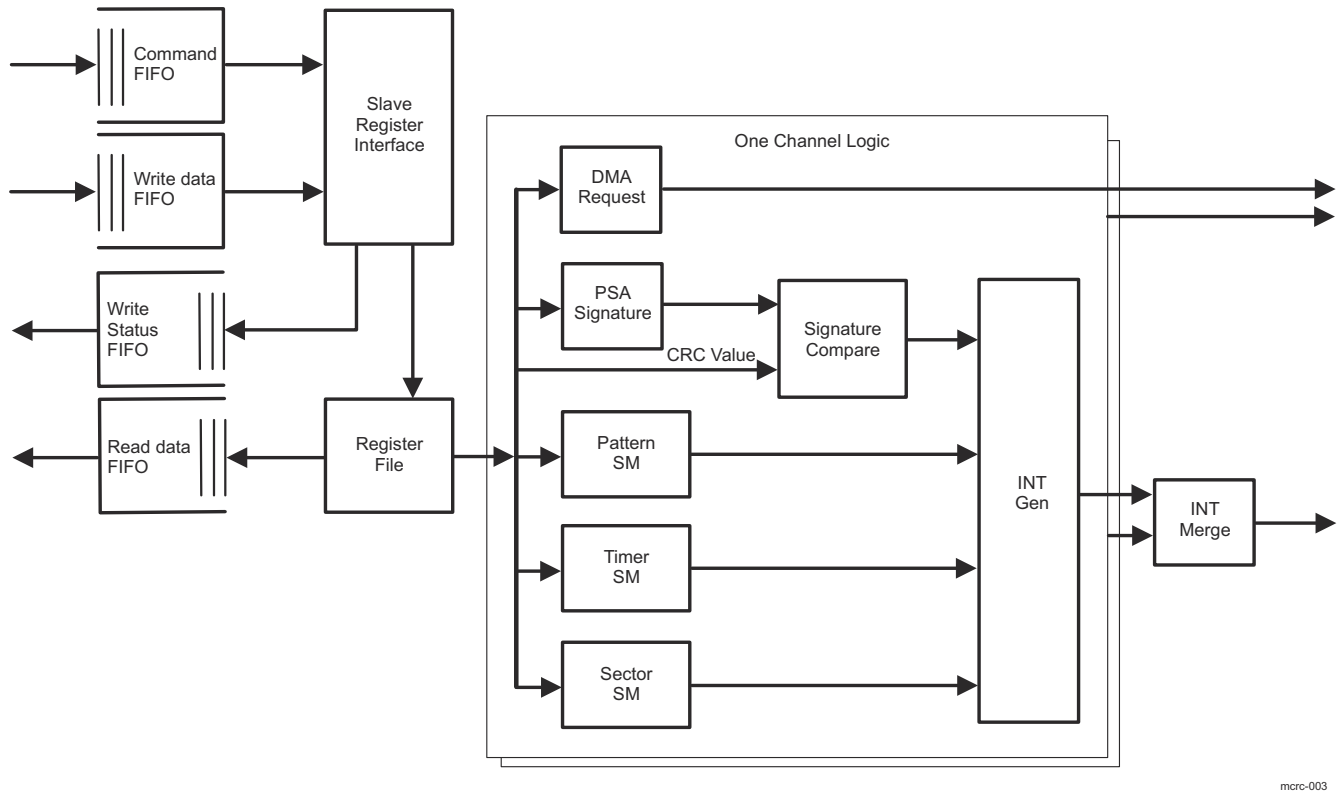

Figure 13-299. MCRC Block Diagram

- **Command FIFO:** The Command FIFO pipelines the commands to the slave register interface. The Command and Write FIFOs allow the data to be coincident for processing. If there is no space for writes in the Write Status FIFO or no space in the Read Data FIFO for reads, the command processing will be halted until there is space in the appropriate FIFO. This FIFO is 4 elements deep.
- **Write FIFO:** The Write FIFO pipelines the write data to the slave register interface. The Command and Write FIFOs allow the data to be coincident for processing. If there is no space for writes in the Write Status FIFO or no space in the Read Data FIFO for reads, the command processing will be halted until there is space in the appropriate FIFO. This FIFO is 2 elements deep.
- **Write Status FIFO:** The Write Status FIFO pipelines the write status back to the VBUSM. A write status will be issued on the final data phase of a write command. This FIFO is 2 elements deep.
- **Read Data FIFO:** The Read Data FIFO pipelines the read data back to the VBUSM. This FIFO is 3 elements deep.
- **Slave Register Interface:** The Slave Register Interface directs the written data to the register file.
- **PSA Signature:** The PSA Signature creates the signature of the data written. This data will then be compared to the CRC Value or read by software to determine goodness.
- **Pattern State Machine:** The Pattern State Machine determines when a block of data has been serviced.
- **Timer State Machine:** The Timer State Machine determines when overrun and under-run events are detected.
- **Sector State Machine:** The Sector State Machine determines when a sector error should be captured so the software can determine the errant block of data.
- **Signature Compare:** The Signature Compare block compares the current signature to the CRC Value register and sends the result to the Interrupt Generation block.

micro-003

13.6.4.3.2 MCRC General Operation

There are four channels in MCRC controller and for each channel there is a PSA (Parallel Signature Analysis) Signature Register (MCRC_PSA_SIGREGL1-4) and a CRC (Cyclic Redundancy Check) Value Register (MCRC_CRC_REGL1-4).

A memory can be organized into multiple sectors with each sector consisting of multiple data patterns. A data pattern can be a 8-, 16-, 32-, or 64-bit data. MCRC module performs the signature calculation and compares the signature to a pre-determined value. The PSA Signature Register compresses an incoming data pattern into a signature when it is written. When one sector of data patterns are written into PSA Signature Register, a final signature corresponding to the sector is obtained. CRC Value Register stores the pre-determined signature corresponding to one sector of data patterns. The calculated signature and the pre-determined signature are then compared to each other for signature verification. To minimize CPU's involvement, data patterns transfer can be carried out at the background of CPU using DMA controller. DMA is setup to transfer data from memory of which the contents to be verified to the memory mapped PSA Signature Register. When DMA transfers data to the memory mapped PSA Signature Register, a signature is generated.

A programmable 20-bit data pattern counter is used for each channel to define the number of data patterns to calculate for each sector. Signature verification can be performed automatically by MCRC controller in AUTO mode or by CPU itself in Semi-CPU or Full-CPU mode. In AUTO mode, a self-sustained CRC signature calculation can be achieved without any CPU intervention.

13.6.4.3.3 MCRC Modes of Operation

MCRC Controller can operate in AUTO, Semi-CPU, and Full-CPU modes.

13.6.4.3.3.1 AUTO Mode

In AUTO mode, MCRC Controller in conjunction with DMA controller can perform CRC without CPU intervention. A sustained transfer of data to both the PSA Signature Register (MCRC_PSA_SIGREGL1-4) and a CRC (Cyclic Redundancy Check) Value Register (MCRC_CRC_REGL1-4) are performed in the background of CPU. When a mismatch is detected, an interrupt is generated to the CPU. A 16-bit, current sector ID register (MCRC_CRC_CURSEC_REG1-4) is provided to identify which sector causes a CRC failure.

13.6.4.3.3.2 Semi-CPU Mode

In Semi-CPU mode, DMA controller is also utilized to perform data patterns transfer to PSA Signature Register (MCRC_PSA_SIGREGL1-4). Instead of performing signature verification automatically, the CRC controller generates an compression complete interrupt to CPU after each sector is compressed. Upon responding to the interrupt the CPU performs the signature verification by reading the calculated signature stored at the PSA Sector Signature Register (MCRC_PSA_SECSIGREGL1-4) and compare it to a pre-determined CRC value.

13.6.4.3.3.3 Full-CPU Mode

In Full-CPU mode, the CPU does the data patterns transfer and signature verification all by itself. When CPU has enough throughput, it can perform data patterns transfer by reading data from the memory system to the PSA Signature Register (MCRC_PSA_SIGREGL1). After certain number of data patterns are compressed, the CPU can read from the PSA Signature Register and compare the calculated signature to the pre-determined CRC signature value. In Full-CPU mode, neither interrupt nor DMA request is generated. All counters are also disabled.

13.6.4.3.4 PSA Signature Register

The 64-bit PSA Signature Register (MCRC_PSA_SIGREGL1-4 and MCRC_PSA_SIGREGH1-4) is based on the primitive polynomial found in (EQ 1) to produce the maximum length LFSR (Linear Feedback Shift Register).

$$f(x) = x^{64} + x^4 + x^3 + x + 1 \quad (27)$$

- A. More details of the 64-bit primitive polynomial can be found at W. Stahnke, Primitive binary polynomials, Math. Comp. 27 (1973), 977–980.

There is one PSA Signature Register per CRC channel. PSA Signature Register can be both read and written. When it is written, it can either compress the data or just capture the data depending on the state of CHI_MODE

bits (where $i = 1$ to 4). If `CHI_MODE=0x0` (Data Capture), a seed value can be planted in the PSA Signature Register without compression. Other modes other than Data Capture will result with the data compressed by PSA Signature Register when it is written. Each channel can be planted with different seed value before compression starts. When PSA Signature Register is read, it gives the calculated signature.

MCRC Controller should be used in conjunction with the on-chip DMA controller to produce optimal system performance. The incoming data pattern to PSA Signature Register is typically initiated by the DMA master. When DMA is properly setup, it would read data from the pre-determined memory system and write them to the memory mapped PSA Signature Register. Each time PSA Signature Register is written a signature is generated. CPU itself can also perform data transfer by reading from the memory system and perform write operation to PSA Signature Register if CPU has enough throughput to handle data patterns transfer.

After a system reset and when AUTO mode is enabled, MCRC Controller automatically generates a DMA request to request the pre-determined CRC value corresponding to the first sector of memory to be checked.

In AUTO mode, when one sector of data patterns is compressed, the signature stored at the PSA Signature Register is first copied to the PSA Sector Signature Register (`MCRC_PSA_SECSIGREGL1-4`) and PSA Signature Register is then cleared out to all zeros. An automatic signature verification is then performed by comparing the signature stored at the PSA Sector Signature Register to the CRC Value Register (`MCRC_CRC_REGL1-4`). After the comparison the MCRC Controller can generate a DMA request. Upon receiving the DMA request the DMA controller will update the CRC Value Register by transferring the next pre-determined signature value associated with the next sector of memory system. If the signature verification fails then MCRC Controller can generate a CRC fail interrupt.

In Full-CPU mode, no DMA request and interrupt are generated at all. The number of data patterns to be compressed is determined by CPU itself. Full-CPU mode is useful when DMA controller is not available to perform background data patterns transfer. Software can periodically generate a software interrupt to CPU and use CPU to accomplish data transfer and signature verification.

MCRC Controller supports double word, word, half word and byte access to the PSA Signature Register. During a non-doubleword write access, all unwritten byte lanes are padded with zeros before compression. Note that comparison between PSA Sector Signature Register and CRC Value Register is always in 64 bits because a compressed value is always expressed in 64 bits.

There is a software reset per channel for PSA Signature Register. When set, the PSA Signature Register is reset to all zeros.

PSA Signature Register is reset to zero under the following conditions:

- System reset
- PSA Software reset
- One sector of data patterns are compressed

13.6.4.3.5 PSA Sector Signature Register

After one sector of data is compressed, the final resulting signature calculated by PSA Signature Register is transferred to the 64-bit PSA Sector Signature Register (`MCRC_PSA_SECSIGREGL1-4` and `MCRC_PSA_SECSIGREGH1-4`). PSA Signature Register is a read-only register. During Semi-CPU mode, the host CPU must read from the PSA Sector Signature Register instead of reading from PSA Signature Register for signature verification to avoid data coherency issue. The PSA Signature Register can be updated with new signature before the host CPU is able to retrieve it.

In Semi-CPU mode, no DMA request is generated. When one sector of data patterns is compressed, CRC controller first generates a compression complete interrupt. Responding to the interrupt, CPU will read the PSA Sector Signature Register and compare it to the known good signature or write the signature value to another memory location to build a signature file. In Semi-CPU mode, CPU must perform the signature verification in a manner to prevent any overrun condition. The overrun condition occurs when the compression complete interrupt is generated after one sector of data patterns is compressed and CPU has not read from the PSA Sector Signature Register to perform necessary signature verification before PSA Sector Signature Register is overridden with a new value. An overrun interrupt can be enabled to generate when overrun condition occurs.

13.6.4.3.6 CRC Value Register

Associated with each channel there is a 64-bit CRC Value Register (MCRC_CRC_REGL1-4 and MCRC_CRC_REGH1-4).

The CRC Value Register stores the pre-determined CRC value. After one sector of data patterns is compressed by PSA Signature Register, MCRC Controller can automatically compare the resulting signature stored at the PSA Sector Signature Register with the pre-determined value stored at the CRC Value Register if AUTO mode is enabled. If the signature verification fails, MCRC Controller can be enabled to generate an CRC fail interrupt. When the channel is set up for Semi-CPU mode, CRC controller first generates a compression complete interrupt to CPU. Upon servicing the interrupt, CPU will then read the PSA Sector Signature Register and then read the corresponding CRC value stored at another location and compare them. CPU must not read from the CRC Value Register during Semi-CPU or Full-CPU mode because the CRC Value Register is not updated during these two modes.

In AUTO mode, for first sector's signature, DMA request is generated when mode is programmed to AUTO. For subsequent sectors, DMA request is generated after each sector is compressed. Responding to the DMA request, DMA controller reloads the CRC Value Register for the next sector of memory system to be checked. The user software needs to configure the DMA to ensure that the DMA first writes to the MCRC_CRC_REGL1 followed by the MCRC_CRC_REGH1 register in during the AUTO Mode.

When CRC Value Register is updated with a new CRC value, an internal flag is set to indicate that CRC Value Register contains the most current value. This flag is cleared when CRC comparison is performed. Each time at the end of the final data pattern compression of a sector, MCRC Controller first checks to see if the corresponding CRC Value Register has the most current CRC value stored in it by polling the flag. If the flag is set then the CRC comparison can be performed. If the flag is not set then it means the CRC Value Register contains stale information. A CRC underrun interrupt is generated. When an underrun condition is detected, signature verification is not performed.

MCRC Controller supports double word, word, half word and byte access to the CRC Value Register. As noted before comparison between PSA Sector Signature Register and CRC Value Register during AUTO mode is carried out in 64 bits.

13.6.4.3.7 Raw Data Register

The raw or un-compressed data written to the PSA Signature Register is also saved in the 64-bit Raw Data Register (MCRC_RAW_DATAREGL1-4 and MCRC_RAW_DATAREGH1-4). This register is read only.

13.6.4.3.8 Example DMA Controller Setup

DMA controller needs to be setup properly in either AUTO or Semi-CPU mode as DMA controller is used to transfer data patterns. Hardware or a combination of hardware and software DMA triggering are supported.

13.6.4.3.8.1 AUTO Mode Using Hardware Timer Trigger

There are two DMA channels associated with each CRC channel when in AUTO mode. One DMA channel is setup to transfer data patterns from the source memory to the PSA Signature Register (MCRC_PSA_SIGREGL1-4). The second DMA channel is setup to transfer the pre-determined signature to the CRC Value Register (MCRC_CRC_REGL1-4). The trigger source for the first DMA channel can be either by hardware or by software. As illustrated in [Figure 13-300](#), a timer can be used to trigger a DMA request to initiate transfer from the source memory system to PSA Signature Register. In AUTO mode, MCRC Controller also generates DMA request after one sector of data patterns is compressed to initiate transfer of the next CRC value corresponding to the next sector of memory. Thus a new CRC value is always updated in the CRC Value Register (MCRC_CRC_REGL1-4) by DMA synchronized to each sector of memory.

A block of memory system is usually divided into many sectors. All sectors are the same size. The sector size is programmed in the MCRC_CRC_PCOUNT_REG1-4 and the number of sectors in one block is programmed in the MCRC_CRC_SCOUNT_REG1-4 of the respective channel. MCRC_CRC_PCOUNT_REG1-4 multiplies MCRC_CRC_SCOUNT_REG1-4 and multiplies transfer size of each data pattern should give the total block size in number of bytes.

The total size of the memory system to be examined is also programmed in the respective transfer count register inside DMA module. The DMA transfer count register is divided into two parts. They are element count and frame count. Note that a hardware DMA request can be programmed to trigger either one frame or one entire block transfer. In [Figure 13-300](#), a hardware DMA request from a timer is used as a trigger source to initiate DMA transfer. If all four CRC channels are active in AUTO mode then a total of four DMA requests would be generated by MCRC Controller.

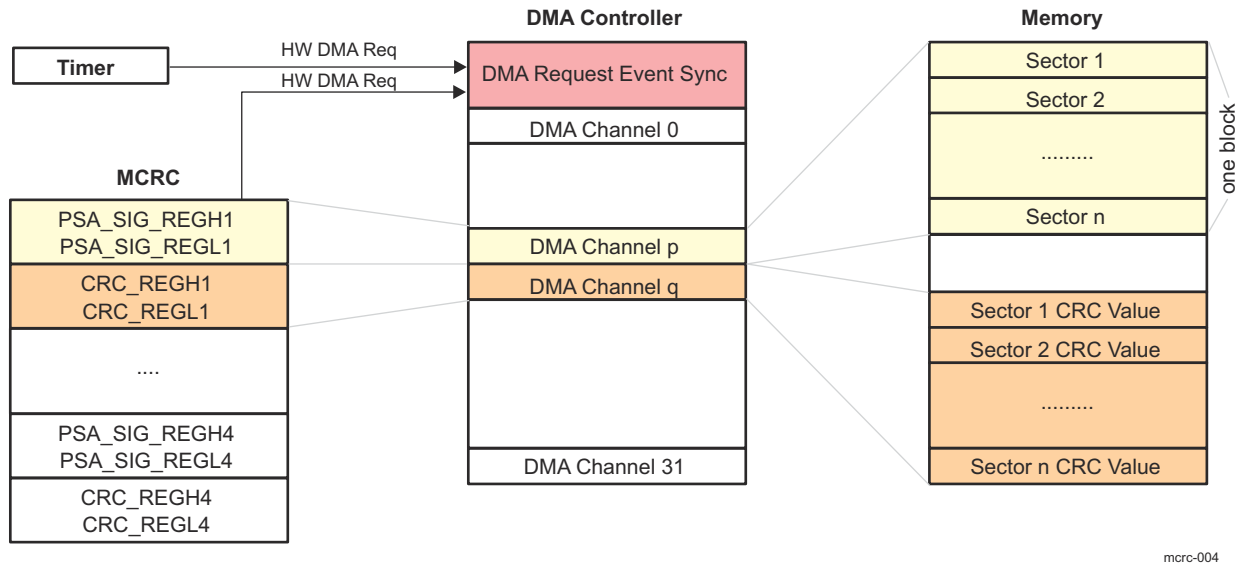

Figure 13-300. AUTO Mode Using Hardware Timer Trigger

13.6.4.3.8.2 AUTO Mode Using Software Trigger

The data patterns transfer can also be initiated by software. CPU can generate a software DMA request to activate the DMA channel to transfer data patterns from source memory system to the PSA Signature Register. To generate a software DMA request CPU needs to set the corresponding DMA channel in the DMA software trigger register. Note that just one software DMA request from CPU is enough to complete the entire data patterns transfer for all sectors. Please see [AUTO Mode With Software CPU Trigger](#) for illustration.

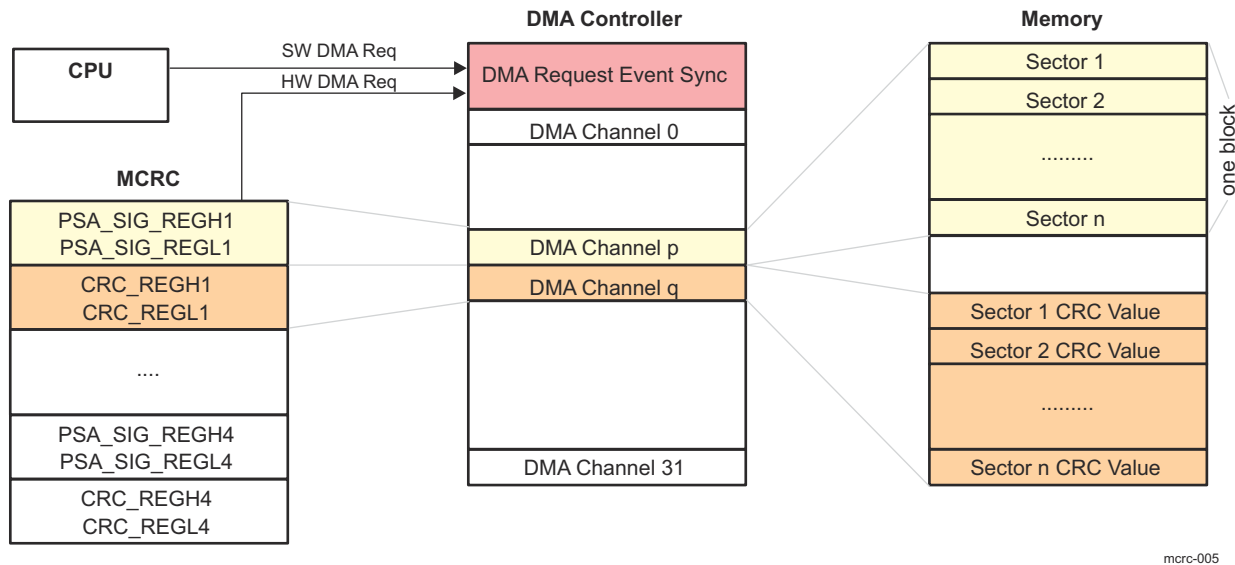

Figure 13-301. AUTO Mode With Software CPU Trigger

13.6.4.3.8.3 Semi-CPU Mode Using Hardware Timer Trigger

During Semi-CPU mode, no DMA request is generated by CRC controller. Therefore, no DMA channel is allocated to update CRC Value Register. CPU should not read from CRC Value Register in semi-CPU mode as it contains stale value. Note that no signature verification is performed at all during this mode. Similar to AUTO mode, either by hardware or by software DMA request can be used as a trigger for data patterns transfer. Figure 13-302 illustrates the DMA setup using semi-CPU mode with hardware timer trigger.

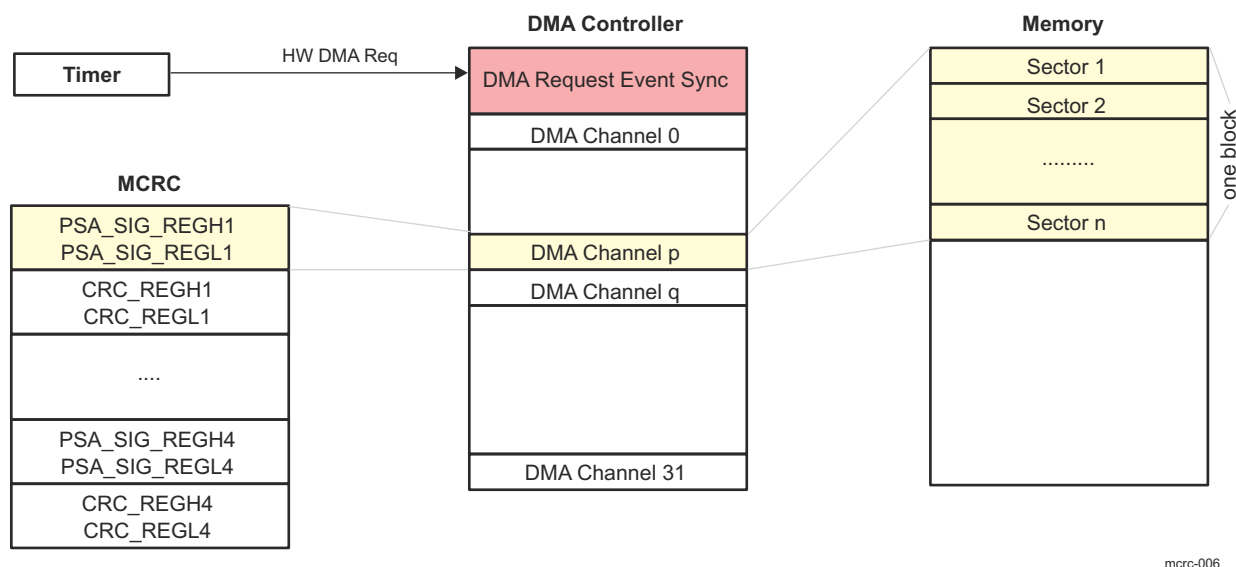

Figure 13-302. Semi-CPU Mode With Hardware Timer Trigger

Table 13-315. DMA Request and Counter Logic Operation According to CRC Mode

CRC Mode	DMA Request	Pattern Counter	Sector Counter	Timeout Counter
AUTO	Active	Active	Active	Active
Semi-CPU	Inactive	Active	Active	Active
Full CPU	Inactive	Inactive	Inactive	Inactive

13.6.4.3.9 Pattern Count Register

There is a 20-bit data pattern counter for every CRC channel. The data pattern counter is a down counter and can be pre-loaded with a programmable value stored in the Pattern Count Register (MCRG_CRC_PCOUNT_REG1-4). When the data pattern counter reaches zero, a compression complete interrupt is generated in Semi-CPU mode and an automatic signature verification is performed in AUTO mode. In AUTO only, DMA request is generated to trigger the DMA controller to update the CRC Value Register.

Note

The data pattern count must be divisible by the total transfer count as programmed in DMA controller. The total transfer count is the product of element count and frame count.

13.6.4.3.10 Sector Count Register/Current Sector Register

Each channel contains a 16-bit sector counter. The sector count register stores the number of sectors. Sector counter is a free running counter and is incremented by one each time when one sector of data patterns is compressed. When the signature verification fails, the current value stored in the sector counter is saved into current sector register (MCRG_CRC_CURSEC_REG1-4). If signature verification fails, CPU can read from the current sector register to identify the sector which causes the CRC mismatch. To aid and facilitate the CPU in determining the cause of a CRC failure it is advisable to use the following equation during CRC and DMA setup.

$$\text{CRC Pattern Count} \times \text{CRC Sector Count} = \text{DMA Element Count} \times \text{DMA Frame Count} \quad (28)$$

The current sector register is frozen from being updated until both the current sector register is read and CRC fail (CHi_CRC_FAIL) status bit is cleared by CPU. If CPU does not respond to the CRC failure in a timely manner before another sector produces a signature verification failure, the current sector register is not updated with the new sector number. An overrun interrupt is generate instead. If current sector register is already frozen with an erroneous sector and emulation is entered with SUSPEND signal goes to high then the register still remains frozen even it is read.

In Semi-CPU mode, the current sector register is used to indicate the sector for which the compression complete has last happened.

Current sector register is reset when the PSA software reset is enabled.

Note

Both data pattern count and sector count registers must be greater than or equal to one for the counters to count. After reset, pattern count and sector count registers default to zero and the associated counters are inactive.

13.6.4.3.11 Interrupts

CRC generate several types of interrupts per channel. Associated with each interrupt there is a interrupt enable bit (see MCRC_CRC_INTS). No interrupt is generated in Full-CPU mode.

- Compression complete interrupt
- CRC fail interrupt
- Overrun interrupt
- Underrun interrupt
- Timeout interrupt

Table 13-316. Interrupt Conditions Per CRC Mode

CRC Mode	Compression Complete	CRC Fail	Overrun	Underrun	Timeout
AUTO	No	Yes	Yes	Yes	Yes
Semi-CPU	Yes	No	Yes	No	Yes
Full-CPU	No	No	No	No	No

13.6.4.3.11.1 Overrun Interrupt

Overrun Interrupt is generated in either AUTO or Semi-CPU mode. During AUTO mode, if a CRC fail is detected then the current sector number is recorded in the current sector register (MCRC_CRC_CURSEC_REG1-4). If CRC fail status bit is not cleared and current sector register is not read by the host CPU before another CRC fail is detected for another sector then an overrun interrupt is generated. During Semi-CPU mode, when the data pattern counter finishes counting, it generates a compression complete interrupt. At the same time the signature is copied into the PSA Sector Signature Register (MCRC_PSA_SECSIGREGL1-4). If the host CPU does not read the signature from PSA Sector Signature Register before it is updated again with a new signature value then an overrun interrupt is generated.

13.6.4.3.11.2 Timeout Interrupt

To ensure that the memory system is examined within a pre-defined time frame and no loss of incoming data there is a 24-bit timeout counter per CRC channel. The timeout counter can be pre-loaded with two different pre-load values, watchdog timeout pre-load value (MCRC_CRC_WDTPLD1-4) and block complete timeout pre-load value (MCRC_CRC_BCTOPLD1-4). The timeout counter is clocked by a prescaler clock which is permanently running at division 64 of FICLK clock.

Watchdog timeout pre-load register (MCRC_CRC_WDTPLD1-4) is used to check if DMA does supply a block of data responding to a request in a given time frame. Block complete timeout pre-load register

(MCRC_CRC_BCTOPLD1-4) is used to check if one complete block of data patterns are compressed within a specific time frame. The timeout counter is first pre-loaded with MCRC_CRC_WDTPD1-4 after either AUTO or Semi-CPU mode is selected and starts to down count. If the timeout counter expires before DMA transfers any data pattern to PSA Signature Register then a timeout interrupt is generated. An incoming data pattern before the timeout counter expires will automatically pre-load the timeout counter with MCRC_CRC_BCTOPLD1-4 the block complete timeout pre-load value.

Block complete timeout pre-load value is used to check if one block of data patterns are compressed within a given time limit. If the timeout counter pre-loaded with MCRC_CRC_BCTOPLD1-4 value expires before one block of data patterns are compressed a timeout interrupt is generated. When one block (pattern count × sector count) of data patterns are compressed before the counter has expired, the counter is pre-loaded with MCRC_CRC_WDTPD1-4 value again. If the timeout counter is pre-loaded with zero then the counter is disabled and no timeout interrupt is generated.

13.6.4.3.11.3 Underrun Interrupt

Underrun interrupt only occurs in AUTO mode. The interrupt is generated when the CRC Value Register is not updated with the corresponding signature when the data pattern counter finishes counting. During AUTO mode, MCRC Controller generates DMA request to update CRC Value Register in synchronization to the corresponding sector of the memory. Signature verification is also performed if underrun condition is detected. And CRC fail interrupt is generated at the same time as the underrun interrupt.

13.6.4.3.11.4 Compression Complete Interrupt

Compression complete interrupt is generated in Semi-CPU mode only. When the data pattern counter reaches zero, the compression complete flag is set and the interrupt is generated.

13.6.4.3.11.5 Interrupt Offset Register

MCRC Controller only generates one interrupt request to interrupt manager. An interrupt offset register (MCRC_CRC_INT_OFFSET_REG) is provided to indicate the source of the pending interrupt with highest priority. [Table 13-317](#) shows the offset interrupt vector address of each interrupt in an ascending order of priority.

Table 13-317. Interrupt Offset Mapping

Interrupt Condition	Offset Value
Phantom	0x0
Ch1 CRC Fail	0x1
Ch2 CRC Fail	0x2
Ch3 CRC Fail	0x3
Ch4 CRC Fail	0x4
reserved	0x5-0x8
Ch1 Compression Complete	0x9
Ch2 Compression Complete	0xA
Ch3 Compression Complete	0xB
Ch4 Compression Complete	0xC
reserved	0xD-0x10
Ch1 Overrun	0x11
Ch2 Overrun	0x12
Ch3 Overrun	0x13
Ch4 Overrun	0x14
reserved	0x15-0x18
Ch1 Underrun	0x19
Ch2 Underrun	0x1A
Ch3 Underrun	0x1B
Ch4 Underrun	0x1C

Table 13-317. Interrupt Offset Mapping (continued)

Interrupt Condition	Offset Value
reserved	0x1D-0x20
Ch1 Timeout	0x21
Ch2 Timeout	0x22
Ch3 Timeout	0x23
Ch4 Timeout	0x24

13.6.4.3.11.6 Error Handling

When an interrupt is generated, host CPU must take appropriate actions to identify the source of error and restart the respective channel in DMA and MCRC module. To restart a CRC channel user must perform the following steps in the ISR:

1. Write to software reset bit in MCRC_CRC_CTRL0 register to reset the respective PSA Signature Register
2. Reset the CHi_MODE bits to 0 in MCRC_CRC_CTRL2 register as Data capture mode
3. Set the CHi_MODE bits in MCRC_CRC_CTRL2 register to desired new mode again
4. Release software reset

The host CPU must use byte write to restart each individual channel.

13.6.4.3.12 Power Down Mode

MCRC module can be put into power down mode when the power down control bit MCRC_CRC_CTRL1[0] PWDN is set. The module wakes up when the PWDN bit is cleared. When MCRC controller is in power down mode, no data tracing alone will happen.

13.6.4.3.13 Emulation

A read access from a register in functional mode can sometimes trigger a certain internal event to follow. For example, reading interrupt offset register triggers an event to clear the corresponding interrupt status flag. During emulation when SUSPEND signal is high, a read access from any register should only return the register contents to the bus and should not trigger or mask any event as it would have in functional mode. This is to prevent debugger from reading the interrupt offset register, that is, during refreshing screen and cause the corresponding interrupt status flag to get cleared. Timeout counters are stopped to generate timeout interrupts in emulation mode. No VBUSM bus error will be generated if reading from the unimplemented locations. .

CEMUDBG is the VBUSM suspend signal which need not explicitly indicate that whether CPU is in suspend mode or not. In data trace mode, a separate suspend signal CPU_EMUSP, is used to indicate MCRC controller that the CPU is in suspend mode or not.

13.6.4.4 MCRC Programming Examples

13.6.4.4.1 Example: Auto Mode Using Time Based Event Triggering

A large memory area with 2 Mbyte (256 k × 32-bit [doubleword]) is to be checked in the background of CPU. CRC is to be performed every 1 Kbyte (128 doubleword). Therefore there will be 2048 pre-recorded CRC values. For illustration purpose, we map MCRC_CRC_REGL1 register to DMA channel 1 and MCRC_PSA_SIGREGL1 register to DMA channel 2. Let's assume all DMA transfers are carried out in 64-bit transfer size.

13.6.4.4.1.1 DMA Setup

- Setup DMA channel 1 with the starting address from which the pre-determined CRC values are stored. Setup the destination address to the MCRC_CRC_REGL1. Put the source address at post increment addressing mode and put the destination address at constant addressing mode. Use hardware DMA request for channel 1 to trigger a frame transfer.
- Setup DMA channel 2 with the source address from which the contents of memory to be verified. Setup the destination address to the MCRC_PSA_SIGREGL1. Program the element transfer count to 128 and the frame transfer count to 2048. Program the read and write element size to 64 bits. Put the source address at post increment addressing mode and put the destination address at constant address mode. Use hardware DMA request for channel 2 to trigger an entire block transfer.

13.6.4.4.1.2 Timer Setup

The timer can be any general purpose timer which is capable of generating a time based DMA request.

- Setup Timer to generate DMA request associated with DMA channel 2. For example, software can setup the timer to generate a DMA request every 10 ms.

13.6.4.4.1.3 CRC Setup

- Program the pattern count MCRC_CRC_PCOUNT_REG1 to 128
- Program the sector count MCRC_CRC_SCOUNT_REG1 to 2048
- For example, we want the entire 2 Mbytes to be compressed within 5 ms. We can program the block complete timeout pre-load (MCRC_CRC_BCTOPLD1-4) value to 15625 (5 ms / (1 FICLK period × 64)) if CRC is operating at 200 MHz.
- Enable AUTO mode and all interrupts.

After AUTO mode is selected MCRC Controller automatically generates a DMA request on channel 1. Around the same time the timer module also generates a DMA request on DMA channel 2. When the first incoming data pattern arrives at the MCRC_PSA_SIGREGL1/H1, the MCRC Controller will compress it. After some time, the DMA controller would update the MCRC_CRC_REGL1/H1 with a pre-determined value matching the calculated signature for the first sector of 128 64-bit data patterns. After one sector of data patterns are compressed, the MCRC Controller generate a CRC fail interrupt if signature stored at the MCRC_PSA_SECSIGREGL1/H1 does not match the MCRC_CRC_REGL1/H1 Register. MCRC Controller generates a DMA request on DMA channel 1 when one sector of data patterns are compressed. This routine will continue until the entire 2 Mbytes are consumed. If the timeout counter reached zero before the entire 2 Mbytes are compressed, a timeout interrupt is generated. After 2Mbytes are transferred, the DMA can generate an interrupt to CPU. The entire operation will continue again when DMA responds to the DMA request from both the timer and MCRC Controller. The CRC is performed totally without any CPU intervention.

13.6.4.4.2 Example: Auto Mode Without Using Time Based Triggering

A small but highly secured memory area with 1 Kbytes is to be checked in the background of CPU. CRC is to be performed every 1 Kbytes. Therefore, there is only one pre-recorded CRC value. For illustration purpose, we map channel 1 MCRC_CRC_REGL1/H1 to DMA channel 1 and channel 1 MCRC_PSA_SIGREGL1/H1 to DMA channel 2. Assume all transfers carried out by DMA are in 64-bit transfer size.

13.6.4.4.2.1 DMA Setup

- Setup DMA channel 1 with the source address from which the pre-determined CRC value is stored. Setup the destination address to the MCRC_CRC_REGL1 Register. Put the source address at constant addressing

mode and put the destination address at constant addressing mode. Use hardware DMA request for channel 1.

- Setup DMA channel 2 with the source address from which the memory area to be verified. Setup the destination address to the MCRC_PSA_SIGREGL1/H1. Program the element transfer count to 128 and the frame transfer count to 1. Put the source address at post increment addressing mode and put the destination address at constant address mode. Generate a software DMA request on channel 2 after CRC has completed its setup. Enable autoinitiation for DMA channel 2.

13.6.4.4.2.2 CRC Setup

- Program the MCRC_CRC_PCOUNT_REG1 to 128
- Program the MCRC_CRC_SCOUNT_REG1 to 1
- Leaving the timeout count MCRC_CRC_BCTOPLD1 register with the reset value of zero means no timeout interrupt is generated
- Enable AUTO mode and all interrupts

After AUTO mode is selected the MCRC Controller automatically generates a DMA request on channel 1. At the same time the CPU generates a software DMA request on DMA channel 2. When the first incoming data pattern arrives at the MCRC_PSA_SIGREGL1/H1, the MCRC Controller will compress it. After some time, the DMA controller would update the MCRC_CRC_REGL1/H1 with a pre-determined value matching the calculated signature for the first sector of 128 64-bit data patterns. After one sector of data patterns are compressed, the MCRC Controller generate a CRC fail interrupt if signature stored at the MCRC_PSA_SECSIGREGL1/H1 does not match the MCRC_CRC_REGL1/H1. MCRC Controller generate a DMA request on DMA channel 1 again after one sector is compressed. After 1 Kbytes are transferred, the DMA can generate an interrupt to CPU. Responding to the DMA interrupt CPU can restart the CRC routine by generating a software DMA request onto channel 2 again.

13.6.4.4.3 Example: Semi-CPU Mode

If DMA controller is available in a system the CRC module can also operate in semi-CPU mode. This means that CPU can still make use of the DMA to perform data patterns transfer to CRC controller in the background. The difference between semi-CPU mode and AUTO mode is that CRC controller does not automatically perform the signature verification. CRC controllers generates a compression complete interrupt to CPU when the one sector of data patterns are compressed. CPU needs to perform the signature verification itself.

A memory area with 2 Mbytes is to be verified with the help of the CPU. CRC operation is to be performed every 1 Kbyte. Since there are 2 Mbytes (256 K doublewords) of memory to be check and we want to perform a CRC every 1 Kbytes (128 doublewords) and therefore there must be 2048 pre-recorded CRC values. In Semi-CPU mode, the MCRC_CRC_REGL1/H1 is not updated and contains indeterminate data.

13.6.4.4.3.1 DMA Setup

- Setup DMA channel 1 with the source address from which the memory area to be verified are mapped. Setup the destination address to the MCRC_PSA_SIGREGL1/H1. Put the starting address at post increment addressing mode and put the destination address at constant address mode. Use hardware DMA request to trigger an entire block transfer for channel 1. Disable autoinitiation for DMA channel 1.

13.6.4.4.3.2 Timer Setup

The timer can be any general purpose timer which is capable of generating a time-based DMA request.

- Setup Timer to generate DMA request associated with DMA channel 1. For example, software can setup the timer to generate a DMA request every 10 ms.

13.6.4.4.3.3 CRC Setup

- Program the MCRC_CRC_PCOUNT_REG1 to 128
- Program the MCRC_CRC_SCOUNT_REG1 to 2048
- For example, we want the entire 2 Mbytes to be compressed within 5 ms. We can program the block complete timeout pre-load value MCRC_CRC_BCTOPLD1 to 15625 (5 ms / (1 FICLK period × 64)) if CRC is operating at 200 MHz
- Enable AUTO mode and all interrupts.

The timer module first generates a DMA request on DMA channel 1 when it is enabled. When the first incoming data pattern arrives at the MCRC_PSA_SIGREGL1/H1, the CRC controller will compress it. After one sector of data patterns are compressed, the CRC controller generate a compression complete interrupt. Upon responding to the interrupt the CPU would read from the MCRC_PSA_SECSIGREGL1/H1. It is up to the CPU on how to deal with the PSA value just read. It can compare it to a known signature value or it can write it to another memory location to build a signature file or even transfer the signature out of the device via SCI or SPI. This routine will continue until the entire 2 Mbytes are consumed. The latency of the interrupt response from CPU can cause overrun condition. If CPU does not read from MCRC_PSA_SECSIGREGL1 before the PSA value is overridden with the signature of the next sector of memory, an overrun interrupt will be generated by CRC controller.

13.6.4.4.4 Example: Full-CPU Mode

In a system without the availability of DMA controller, the CRC routine can be operated by CPU provided the CPU has enough throughput. CPU needs to read from the memory area from which CRC is to be performed.

A memory area with 2 Mbytes is to be checked with the help of the CPU. CRC operation is to be performed every 1 Kbyte. In CPU mode, the MCRC_CRC_REGL1/H1 is not updated and contains indeterminate data.

13.6.4.4.4.1 CRC Setup

- All control registers can be left in their reset state. Only enable Full-CPU mode.

CPU itself reads from the memory and write the data to the MCRC_PSA_SIGREGL1/MCRC_PSA_SIGREGH1 inside MCRC Controller. When the first incoming data pattern arrives at the MCRC_PSA_SIGREGL1/MCRC_PSA_SIGREGH1, the MCRC Controller will compress it. After n data patterns are compressed, CPU can read from the MCRC_PSA_SIGREGL1/MCRC_PSA_SIGREGH1. It is up to the CPU on how to deal with the PSA signature value just read. It can compare it to a known signature value stored at another memory location.

13.6.5 Self-Test Controller (STC)

13.6.5.1 Integration Spec

13.6.5.1.1 STC Memory Map for AM263x

Table 13-318. STC Memory Map for AM263x

Name	Start Address	Frame Address (Hex) End	Size	Description
R5FSS0_STC	0x5350 0000	0x5350 0118	284 Bytes	R5FSS0_STC module configuration registers
R5FSS1_STC	0x5351 0000	0x5351 0118	284 Bytes	R5FSS1_STC module configuration registers

13.6.5.1.2 Features Not Supported

- [Section 13.6.5.4.7.1](#) – Launch-on-last-shift. TR_T =1
- [Section 13.6.5.4.7.2](#) – Transition delay fault model. FT =1
- [Section 13.6.5.4.7.6](#) – Low-power scan mode. MSS_STC.STCGCR1.LP_SCAN_MODE = 1
- [Section 13.6.5.4.7.7](#) and [Section 13.6.5.4.7.8](#) – Coverage improvement techniques – MSS_STC.STCGCR1.ROM_ACCESS_INV =1 mode
- Interval-based testing
- MSS_STC.STC_CLKDIV clock division features.

13.6.5.2 General Description

The enhanced Self-Test Controller (STC) is used to test logic cores based on the On-Product Multiple Input Signature Register (OPMISR) scan compression architecture.

Software-based self-test programs for the cores are available, but offer less test coverage. Due to the complexity of the soft cores, it is difficult to achieve the required coverage; also, the program size is larger.

For these complex cores, on-chip logic BIST support for the self-test is preferred.

The main features of this solution include:

- Implements the OPMISR controller, along with the on-chip self-test controller for the synthesizable module logic, which enables high test coverage.
- Can divide the complete test run into independent test sets (intervals).
- Capable of running the complete test, and running several intervals at a time.
- Can continue from the last executed interval (test set), and restart from the beginning (first interval in the ROM), or start from the first interval of each segment.
- A single self-test controller can support a test of up to 4 logical segments. A segment identifier corresponding to each interval is stored in the self-test ROM.
- The self-test controller facilitates complete isolation of the logical segment under the test from the rest of the system during the self-test run. Configure critical control signals in the master and slave ports of the logical segment under the test to a safe state.
- The self-tested CPU core master bus transaction signals are configured to be in idle mode during the self-test run.
- Can capture the failed segment number.
- Time-out counter for the self-test run as a fail-safe feature.
- Can read the MISR data (shifted from the OPMISR controller) of the last executed interval of the self-test run, for debugging purposes.
- Can capture power reduction using dead cycles before and after the capture pulse.
- Coverage improvements technique – ROM inverse access mode. In this, the patterns are read in a reverse order from ROM and applied to the UUT. Pattern randomization due to this approach results in coverage improvement, without an increase in the number of patterns. Corresponding INV_MISR is also stored in the ROM.

A self test segment corresponds to a portion of discreet safety-critical logic which can be tested in isolation from the rest of the system by the self test controller and OPMISR logic.

13.6.5.2.1 OPMISR Concept

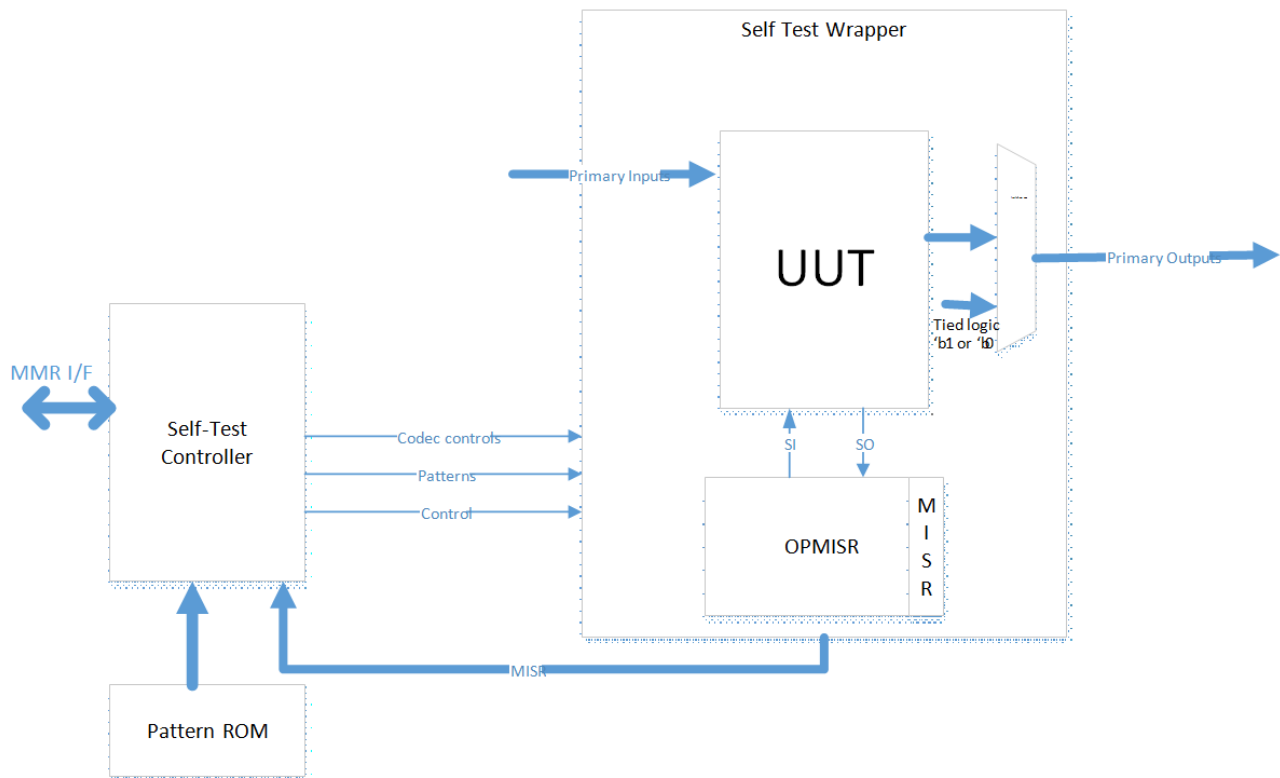

Figure 13-303. OPMISR Conceptual Diagram

The On-Product Multiple-Input Signature Register (OPMISR) is a methodology which moves the test pattern generation on-chip. Logic BIST is implemented on functional partitions (BIST'ed COREs) that are speed-critical and have high gate count. A conceptual diagram of OPMISR implementation is shown in Figure 13-303.

The MISR test structure modifies the typical fullscan scan chain such that each scan data input internally drives many chains. These chains feed to the inserted MISR structure. The chain's values are captured into the MISR during shift, generating a resulting signature that can be shifted out.

A given Unit Under Test (UUT) is scan-inserted, and the scan chains are hooked to the OPMISR logic. The self-test wrapper created around the UUT and the OPMISR logic includes the isolation muxes for the output ports of the core, to ensure that the core and UUT are isolated from the rest of the system during the self-test.

13.6.5.3 Block Diagram

The STC module is composed of following blocks:

- ROM interface
- FSM and sequence control
- Register file
- STC bypass / ATE interface
- Peripheral bus interface (VBUSP interface)

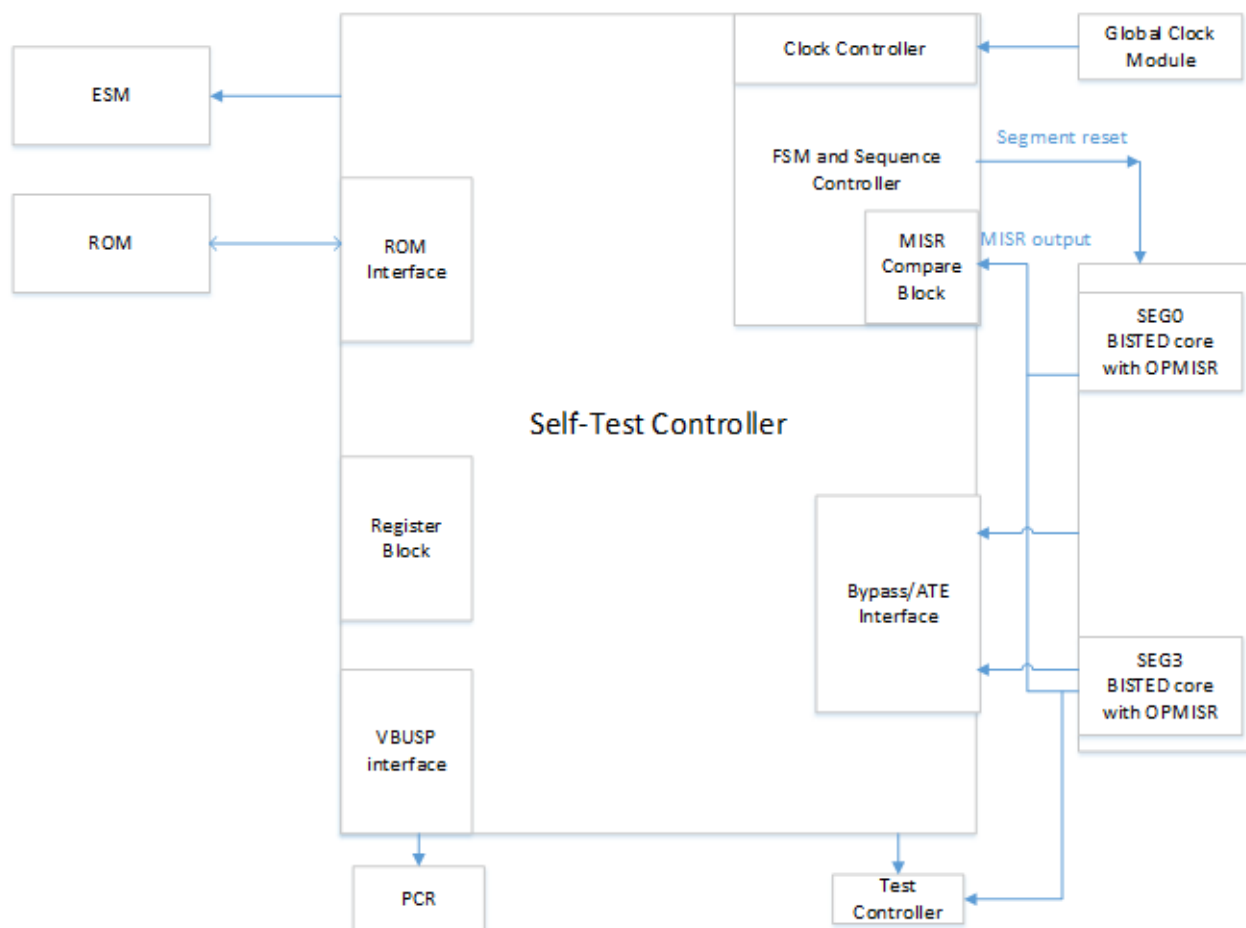

Figure 13-304. Block Diagram for STC With Multiple Segments

13.6.5.4 Module Description

13.6.5.4.1 ROM Interface

This block handles the ROM address and control signal generation to read the self-test microcode from the ROM. The test microcode, patterns, and golden signature value for each interval is stored in ROM.

Detailed information of the ROM microcode is available at ROM.

13.6.5.4.2 FSM and Sequence Control

This block generates the signals and data to OPMISR controller based on the test type and scan chain depth. The sequence of operation per interval is defined in [Section 13.6.5.4.6](#).

13.6.5.4.2.1 Clock Control

The CLOCK CNTRL sub-block handles the clock selection and clock generation for ROM, OPMISR controller, and BIST'ed CORE clocks.

13.6.5.4.2.2 MISR Compare Block

At the end of the each self-test interval, an 896-bit MISR value from the OPMISR controller is shifted into NSTC. This is compared with the MISR_GOLDEN value, which is copied into a buffered register before the start of the interval. The result is updated into the status registers.

13.6.5.4.3 Register Block

This block implements the user-programmable control registers that determine when to start a self test, at what clock frequency the scan test should be performed, which segment to be selected for the test, how many pattern intervals to be completed before stopping, and so forth.

The register block also captures various status information of the self test for the user.

13.6.5.4.4 STC Bypass / ATE Interface

This is a production test interface. This section bypasses the self-test FSM. The OPMISR signal interface is brought out directly to the module ports, and these are accessible to the ATE (tester) at the device level using the test controller module. The intent of the block is to provide capability for fault isolation for parts failing the logic self test run.

This block receives two sets of signals; one from the device test controller, and another similar set from the self-test FSM (test sequencer). The bypass indicator signal is used to select one of the two sets of signals to be routed to the OPMISR controller.

13.6.5.4.5 VBUSP Interface

The control and the status registers of the STC module can be accessed through the VBUSP interface. During application programming, configuration registers are programmed through the peripheral interface, to enable and run the self-test controller.

13.6.5.4.6 STC Flow

ADVANCE INFORMATION

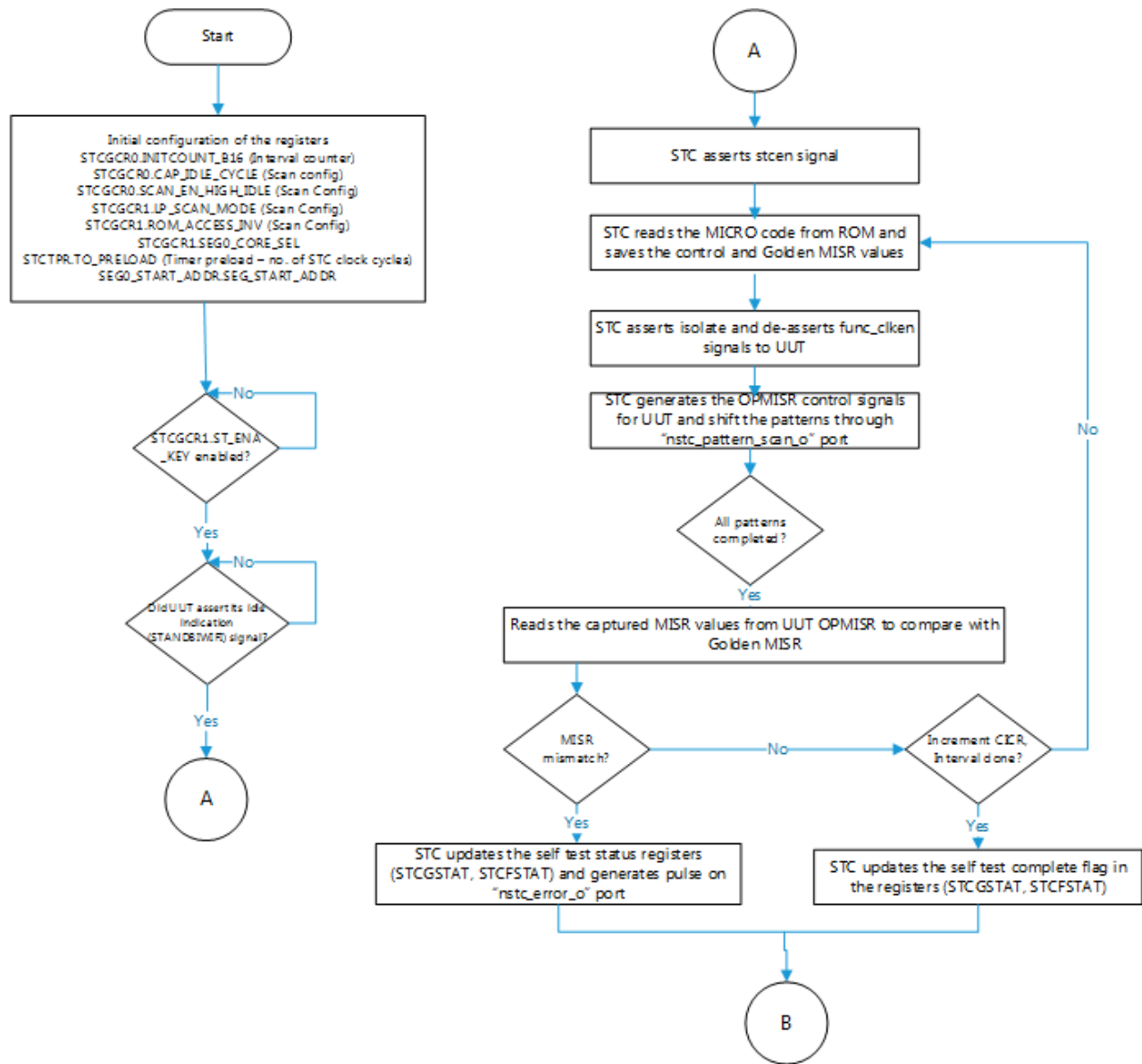

Figure 13-305. STC Flow (1 of 2)

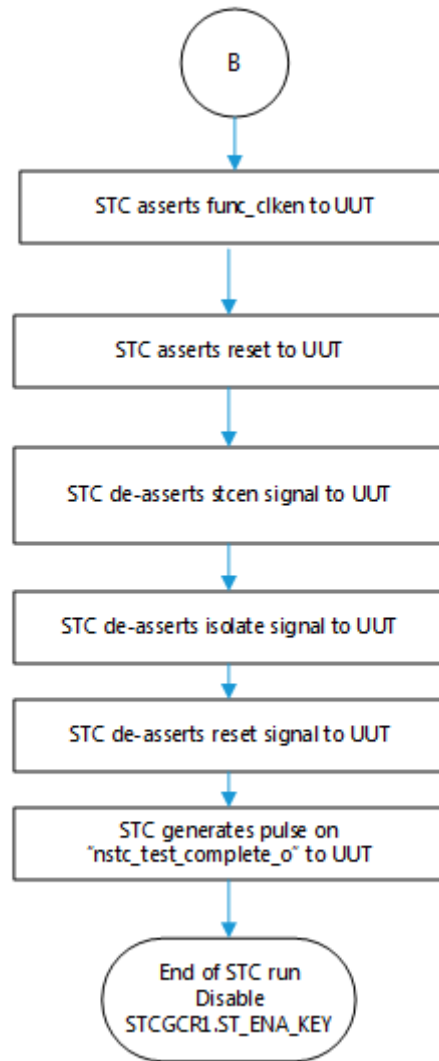

Figure 13-306. STC Flow (2 of 2)

ADVANCE INFORMATION

13.6.5.4.7 ROM Organization

Table 13-319. ROM Organization for 2 Intervals

COMMENTS	55:40	41:32	31:16	15:8	7:4	3	2	1	0
INTERVAL 0									
CFG for interval 0, when rom_access_inversion =0	Reserved	pattern_count[9:0]	Reserved	Reserved	Reserved	Seg_ID[1]	Seg_ID[0]	FT	TR_T

Table 13-319. ROM Organization for 2 Intervals (continued)

COMMENTS	55:40	41:32	31:16	15:8	7:4	3	2	1	0
MISR for interval 0, when rom_access_inversion =0				MISR_GOLDEN[895:840]					
				MISR_GOLDEN[839:784]					
				MISR_GOLDEN[783:728]					
				MISR_GOLDEN[727:672]					
				MISR_GOLDEN[671:616]					
				MISR_GOLDEN[615:560]					
				MISR_GOLDEN[559:504]					
				MISR_GOLDEN[503:448]					
				MISR_GOLDEN[447:392]					
				MISR_GOLDEN[391:336]					
				MISR_GOLDEN[335:280]					
				MISR_GOLDEN[279:224]					
				MISR_GOLDEN[223:168]					
				MISR_GOLDEN[167:112]					
				MISR_GOLDEN[111:56]					
			MISR_GOLDEN[55:0]						
LP_MISR for interval 0, when rom_access_inversion =0				LP_MISR_GOLDEN[895:840]					
				LP_MISR_GOLDEN[839:784]					
				LP_MISR_GOLDEN[783:728]					
				LP_MISR_GOLDEN[727:672]					
				LP_MISR_GOLDEN[671:616]					
				LP_MISR_GOLDEN[615:560]					
				LP_MISR_GOLDEN[559:504]					
				LP_MISR_GOLDEN[503:448]					
				LP_MISR_GOLDEN[447:392]					
				LP_MISR_GOLDEN[391:336]					
				LP_MISR_GOLDEN[335:280]					
				LP_MISR_GOLDEN[279:224]					
				LP_MISR_GOLDEN[223:168]					
				LP_MISR_GOLDEN[167:112]					
				LP_MISR_GOLDEN[111:56]					
			LP_MISR_GOLDEN[55:0]						
Patterns for interval 0	P1_SD8[6:0]	P1_SD7[6:0]	P1_SD6[6 :0]	P1_SD1[6:0]		
		P1_SD9[6:0]	
	

Table 13-319. ROM Organization for 2 Intervals (continued)

COMMENTS	55:40	41:32	31:16	15:8	7:4	3	2	1	0
LP_MISR for interval 0, when rom_access_inversion =1	LP_INV_MISR_GOLDEN[55:0]								
	LP_INV_MISR_GOLDEN[111:56]								
	LP_INV_MISR_GOLDEN[167:112]								
	LP_INV_MISR_GOLDEN[223:168]								
	LP_INV_MISR_GOLDEN[279:224]								
	LP_INV_MISR_GOLDEN[335:280]								
	LP_INV_MISR_GOLDEN[391:336]								
	LP_INV_MISR_GOLDEN[447:392]								
	LP_INV_MISR_GOLDEN[503:448]								
	LP_INV_MISR_GOLDEN[559:504]								
	LP_INV_MISR_GOLDEN[615:560]								
	LP_INV_MISR_GOLDEN[671:616]								
	LP_INV_MISR_GOLDEN[727:672]								
	LP_INV_MISR_GOLDEN[783:728]								
	LP_INV_MISR_GOLDEN[839:784]								
LP_INV_MISR_GOLDEN[895:840]									
MISR for interval 0, when rom_access_inversion =1	INV_MISR_GOLDEN[55:0]								
	INV_MISR_GOLDEN[111:56]								
	INV_MISR_GOLDEN[167:112]								
	INV_MISR_GOLDEN[223:168]								
	INV_MISR_GOLDEN[279:224]								
	INV_MISR_GOLDEN[335:280]								
	INV_MISR_GOLDEN[391:336]								
	INV_MISR_GOLDEN[447:392]								
	INV_MISR_GOLDEN[503:448]								
	INV_MISR_GOLDEN[559:504]								
	INV_MISR_GOLDEN[615:560]								
	INV_MISR_GOLDEN[671:616]								
	INV_MISR_GOLDEN[727:672]								
	INV_MISR_GOLDEN[783:728]								
	INV_MISR_GOLDEN[839:784]								
INV_MISR_GOLDEN[895:840]									
CFG for interval 0, when rom_access_inversion =1 (same as when_rom_access_inversion =0)	Reserved	pattern_count[9:0]	Reserved	Reserved	Reserved	Seg_ID[1]	Seg_ID[0]	FT	TR_T
INTERVAL 1									
CFG for interval 1, when rom_access_inversion =0	Reserved	pattern_count[9:0]	Reserved	Reserved	Reserved	Seg_ID[1]	Seg_ID[0]	FT	TR_T

Table 13-319. ROM Organization for 2 Intervals (continued)

COMMENTS	55:40	41:32	31:16	15:8	7:4	3	2	1	0
MISR for interval 1, when rom_access_inversion =0				MISR_GOLDEN[895:840]					
				MISR_GOLDEN[839:784]					
				MISR_GOLDEN[783:728]					
				MISR_GOLDEN[727:672]					
				MISR_GOLDEN[671:616]					
				MISR_GOLDEN[615:560]					
				MISR_GOLDEN[559:504]					
				MISR_GOLDEN[503:448]					
				MISR_GOLDEN[447:392]					
				MISR_GOLDEN[391:336]					
				MISR_GOLDEN[335:280]					
				MISR_GOLDEN[279:224]					
				MISR_GOLDEN[223:168]					
				MISR_GOLDEN[167:112]					
				MISR_GOLDEN[111:56]					
			MISR_GOLDEN[55:0]						
LP_MISR for interval 1, when rom_access_inversion =0				LP_MISR_GOLDEN[895:840]					
				LP_MISR_GOLDEN[839:784]					
				LP_MISR_GOLDEN[783:728]					
				LP_MISR_GOLDEN[727:672]					
				LP_MISR_GOLDEN[671:616]					
				LP_MISR_GOLDEN[615:560]					
				LP_MISR_GOLDEN[559:504]					
				LP_MISR_GOLDEN[503:448]					
				LP_MISR_GOLDEN[447:392]					
				LP_MISR_GOLDEN[391:336]					
				LP_MISR_GOLDEN[335:280]					
				LP_MISR_GOLDEN[279:224]					
				LP_MISR_GOLDEN[223:168]					
				LP_MISR_GOLDEN[167:112]					
				LP_MISR_GOLDEN[111:56]					
			LP_MISR_GOLDEN[55:0]						
Patterns for interval 1	P1_SD8[6:0]	P1_SD7[6:0]	P1_SD6[6 :0]	P1_SD1[6:0]		
		P1_SD9[6:0]	
	

Table 13-319. ROM Organization for 2 Intervals (continued)

COMMENTS	55:40	41:32	31:16	15:8	7:4	3	2	1	0
LP_MISR for interval 1, when rom_access_inversion =1	LP_INV_MISR_GOLDEN[55:0]								
	LP_INV_MISR_GOLDEN[111:56]								
	LP_INV_MISR_GOLDEN[167:112]								
	LP_INV_MISR_GOLDEN[223:168]								
	LP_INV_MISR_GOLDEN[279:224]								
	LP_INV_MISR_GOLDEN[335:280]								
	LP_INV_MISR_GOLDEN[391:336]								
	LP_INV_MISR_GOLDEN[447:392]								
	LP_INV_MISR_GOLDEN[503:448]								
	LP_INV_MISR_GOLDEN[559:504]								
	LP_INV_MISR_GOLDEN[615:560]								
	LP_INV_MISR_GOLDEN[671:616]								
	LP_INV_MISR_GOLDEN[727:672]								
	LP_INV_MISR_GOLDEN[783:728]								
	LP_INV_MISR_GOLDEN[839:784]								
LP_INV_MISR_GOLDEN[895:840]									
MISR for interval 1, when rom_access_inversion =1	INV_MISR_GOLDEN[55:0]								
	INV_MISR_GOLDEN[111:56]								
	INV_MISR_GOLDEN[167:112]								
	INV_MISR_GOLDEN[223:168]								
	INV_MISR_GOLDEN[279:224]								
	INV_MISR_GOLDEN[335:280]								
	INV_MISR_GOLDEN[391:336]								
	INV_MISR_GOLDEN[447:392]								
	INV_MISR_GOLDEN[503:448]								
	INV_MISR_GOLDEN[559:504]								
	INV_MISR_GOLDEN[615:560]								
	INV_MISR_GOLDEN[671:616]								
	INV_MISR_GOLDEN[727:672]								
	INV_MISR_GOLDEN[783:728]								
	INV_MISR_GOLDEN[839:784]								
INV_MISR_GOLDEN[895:840]									
CFG for interval 1, when rom_access_inversion =1 (same as when_rom_access_inversion =0)	Reserved	pattern_count[9:0]	Reserved	Reserved	Reserved	Seg_ID[1]	Seg_ID[0]	FT	TR_T

The ROM contains the data to be processed by STC for the self-test run. This includes the control fields such as Segment ID, Pattern Count, and Golden MISR value for the STC, and the pattern scan data for the OPMISR controller.

The ROM space is divided into chunks, with each chunk containing the data corresponding to one OPMISR interval. The size required for an interval varies depending on the number patterns packed into the interval and the length of internal scan chains required.

Because each interval requires 64 rows of ROM for storing control and Golden MISR values, minimizing the number of intervals by packing more patterns into each interval provides the best ROM size. This works best if the self-test must be run only as a part of the boot-up sequence. However, if the self-test is performed during

application IDLE time, the number of patterns that can be packed into each interval will be dictated by the IDLE time available for the self-test, because an interval is the smallest granularity of a self-test run.

Details of the ROM image micro-code fields are given in the following sections.

13.6.5.4.7.1 TR_T: Transition Delay Methodology Type

This specifies the transition delay methodology for the current transition delay interval.

0	Launch-on-System-Clock
---	------------------------

13.6.5.4.7.2 FT: Fault Model for the BIST Run

This specifies the fault model for the current interval of the test.

0	Stuck-at
---	----------

13.6.5.4.7.3 SEG_ID[1:0]

This indicates which logical segment is selected for the associated interval during the self-test run.

SEG_SEL[1:0]	Segment Under Test
00	Segment 0
01	Segment 1
10	Segment 2
11	Segment 3

13.6.5.4.7.4 Pattern Count (patt_count[9:0])

This specifies the number of scan data patterns within a self-test interval. The pattern counts can vary from a minimum of 2 to a maximum of 1024.

patt_count[9:0]	Patterns per Interval
00_0 000_ 0000	Not a valid interval [defaults to 2 patterns per interval]
00_0 000_ 0001	2 patterns per interval
00_0 000_ 0010	3 patterns per interval
...	...
11_11 11_11 10	1023 patterns per interval
11_11 11_11 11	1024 patterns per interval

13.6.5.4.7.5 MISR_GOLDEN[895:0]: Golden Signature Data Bits

This part of ROM contains the golden signature data of the current interval. This value is used to compare with the actual MISR value, when ST_GCR1.ROM_ACCESS_INV=0 and ST_GCR1.LP_SCAN_MODE=0, to generate the pass/fail information of the interval.

13.6.5.4.7.6 LP_MISR_GOLDEN[895:0]: Low Power Mode Golden Signature Data Bits

This part of ROM contains the LP golden signature data of the current interval. This value is used to compare with the actual MISR value, when STCGCR1.ROM_ACCESS_INV=0 and STCGCR1.LP_SCAN_MODE=1, to generate the pass/fail information of the interval.

13.6.5.4.7.7 INV_MISR_GOLDEN[895:0]: Inverse Mode Golden Signature Data Bits

This part of ROM contains the inverse mode golden signature data of the current interval. This value is used to compare with the actual MISR value, when STCGCR1.ROM_ACCESS_INV=1 and STCGCR1.LP_SCAN_MODE=0, to generate the pass/fail information of the interval.

13.6.5.4.7.8 LP_INV_MISR_GOLDEN[895:0]: Low Power Inverse Mode Golden Signature Data Bits

This part of ROM contains the low-power inverse mode golden signature data of the current interval. This value is used to compare with the actual MISR value, when STCGCR1.ROM_ACCESS_INV=1 and STCGCR1.LP_SCAN_MODE=1, to generate the pass/fail information of the interval.

13.6.5.4.7.9 Pn_SDm[7:0] (n - no. of patterns, m - scan chain length): OP-MISR Scan Data

This part of the ROM contains the scan data corresponding to each pattern. Each interval can have n number of scan patterns, as defined in the patt_count field. The number of 7bits of scan data in a pattern is equal to the length of the scan chain formed inside the UUT.

This page intentionally left blank.



The debug subsystem contains the OneMCU DEBUGSS at its core and enables JTAG interface access to device components. The debug subsystem is designed to provide the following debug features:

- JTAG debug access to debug resources, mapped through an ARM SWJ-DP and TI ICEPickM scan module
- System memory access without halting the processor
- ETM-based trace for ARM R5F
- Cross trigger to halt and restart cores and peripherals based on events such as watchdog, timers, DMA, and time-stamp events
- Capability to read the device ID data

14.1 On-Chip Debug	1526
---------------------------------	-------------

14.1 On-Chip Debug

This chapter describes the on-chip debug support, including details on the various capabilities and features available through the SoC debug framework.

14.1.1 On-Chip Debug Overview

This chapter describes the properties and capabilities of the various features available through the On-Chip Debug framework deployed on this device.

The On-Chip Debug framework enables various Debug and Trace use-cases, including:

- JTAG Tooling – Access to on-chip debug resources is supported by an IEEE 1149.1 (JTAG) compliant interface that is supported by an Arm® CoreSight™ DAP JTAG-DP.
- Self-Hosted Tooling – code running on programmable cores within the device is able to use on-chip debug resources to enable embedded tooling solutions.
- PCB-level interconnect testing – IEEE 1149.1 and IEEE 1149.6 compliant Boundary Scan supports product level integration testing
- Stop Mode debugging – Debug of embedded processors is supported using various mechanisms that can halt the pipeline of a CPU. Breakpoints (Software and Hardware), Watchpoints, Cross-Triggering, and On-demand (e.g. user requested) halt request mechanisms may be supported based on the capabilities of a given processor.
- Debug-aware Peripherals – Peripheral awareness of processor execution state allows safe suspension of peripheral operation. Supported by select peripherals.
- Synchronized Debug – Wide deployment of Cross-Triggering allows multiple processors and/or debug elements to be grouped together to process various actions based on a common event occurrence.
- Processor Trace – Support for the generation of a trace stream with the encoding of processor state that may include some combination of program flow, timing details (execution and stall), and memory references (address and/or data) with the goal of facilitating processor state reconstruction for debug purposes.
- Software Messaging Trace – Support for software messaging trace where embedded code running within the device can be instrumented to use memory writes to send important debug information to a trace stream.
- Trace Correlation (through timestamping) – Support for the correlation of different trace streams is enabled through the use of a common global timestamp that is distributed to supported trace sources.
- Trace data movement – Trace data movement on chip is supported using standard Arm ATB trace infrastructure components. Concurrent use of the trace bus by multiple trace sources is supported, with each trace source identifiable through a unique ID. An Arm® CoreSight™ Trace Router supports sending a trace stream off-chip (TPIU), to dedicated memory on-chip (ETB), or broadcasted to both (TPIU + ETB).
- On-Chip trace collection via dedicated buffer – An on-chip trace buffer is supported by logic that implements capturing trace data until either the memory fills (stop-on-full, system-bridge) or continuously until a request to stop is received (circular buffer). Interleaving of multiple trace streams is made possible through the use of a standardized encoding that embeds trace data along with the corresponding trace source ID.
- Trace export over TPIU – Trace data is exported over device LVCMOS pins using a standard protocol that embeds trace data along with the corresponding trace source ID.

14.1.2 On-Chip Debug Features

The On-Chip Debug framework provides a comprehensive hardware platform for a rich debug and development experience. The On-Chip Debug framework in AM263x supports these features:

- An IEEE 1149.1 (JTAG and Boundary Scan) compliant device interface to provide debug access to debug resources through ARM SWJ-DP module.
- System Memory access without halting the processors
- Trace port device interface
- ETM based program flow trace for ARM R5F
- Software instrumentation trace using STM
- Breakpoint-based debug
- Cross-trigger to halt and restart various R5F cores and M4 CPU based on SOC internal and external events such as timers and other peripheral interrupts
- Trace capture on-chip via dedicated buffer

- Arm® CoreSight™ compliant debug components deployed to streamline 3rd party tooling support

14.1.3 On-Chip Debug Functional Description

14.1.3.1 On-Chip Debug Block Diagram

The Debug subsystem is responsible for supporting the debug features of AM263x device.

An overview of the interconnectivity of the debug ports and trace ports are shown in [Figure 14-1](#).

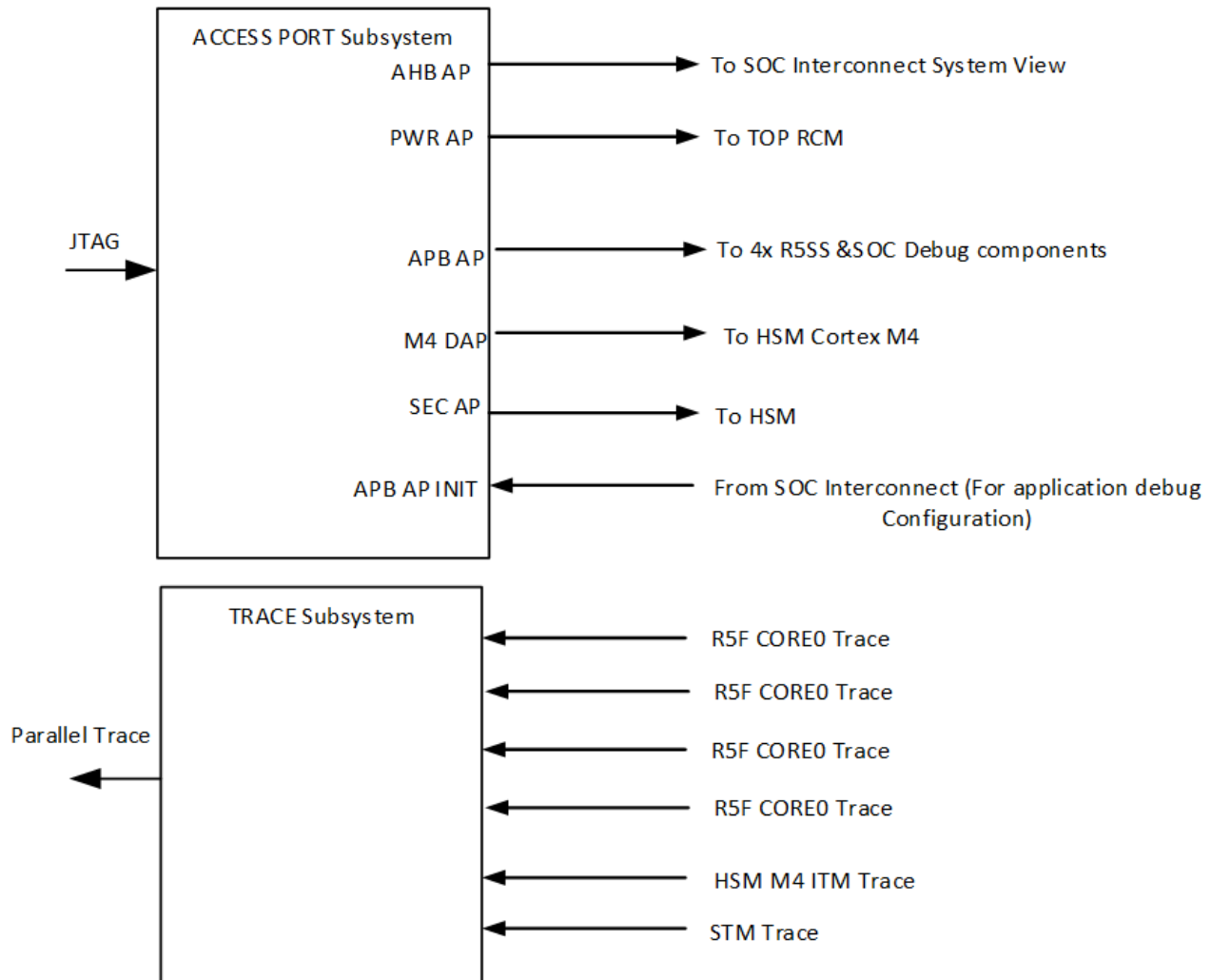

Figure 14-1. Debug SS Overview

A logical partitioning of the On-Chip Debug features deployed on this device is illustrated in [Figure 14-2](#).

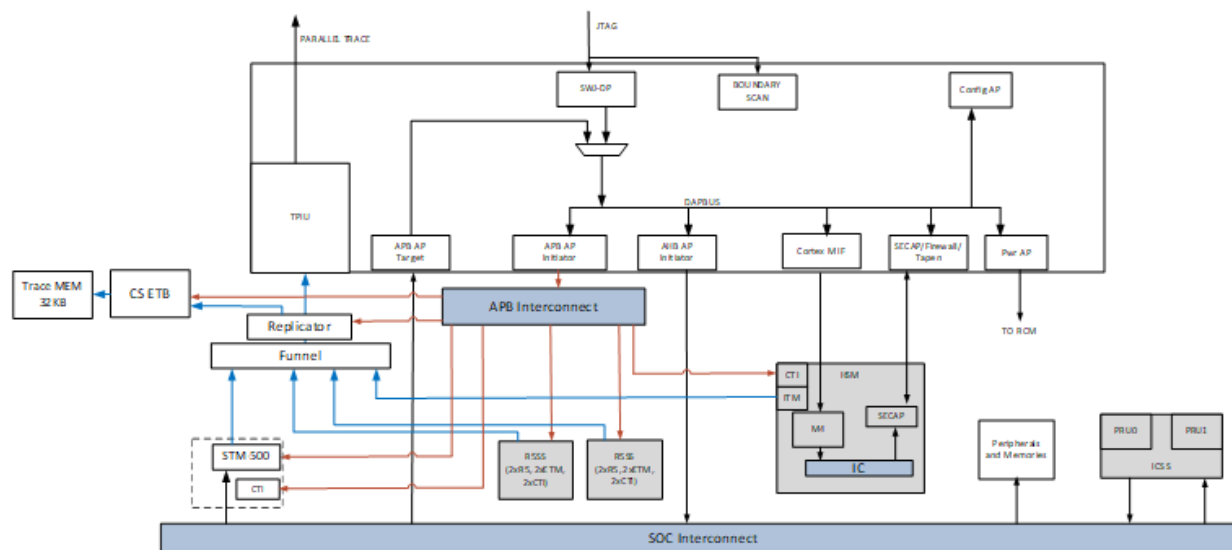

Figure 14-2. On Chip Debug Block Diagram

14.1.3.2 Device Interfaces

On-Chip Debug features are supported through two device interfaces.

JTAG: IEEE 1149.1 compliant interface that provides access to Boundary Scan and acts as the primary interface for off-chip access to On-Chip debug resources (see Section 14.1.3.2.1).

Trace Port: Arm TPIU compliant Trace Port interface is used to facilitate export of trace (see Section 14.1.3.2.2).

Texas Instruments supports a variety of eXtended Development System (XDS) JTAG controllers with various debug capabilities beyond only JTAG support. The following document is a good reference for guidelines: Emulation and Trace Headers. More information can also be found here: XDS Target Connection Guide.

14.1.3.2.1 JTAG Interface

Table 14-1. JTAG Interface Signals

Signal Name	I/O Type	Description
TCK	I	<i>Test Clock.</i> Controls the timing of the test interface independently from any system clocks. TCK is pulsed by the equipment controlling the test and not by the tested device.
TMS	I	<i>Test Mode Select.</i> Controls the transitions of the test interface state machine
TDI	I	<i>Test Data Input.</i> Supplies the data to the JTAG registers
TDO	O/Z	<i>Test Data Output.</i> Used to serially output the data from the JTAG registers to the equipment controlling the test.

14.1.3.2.2 Trace Port Interface

Table 14-2. Trace Port Signals

Signal Name	I/O Type	Description
TRC_CLK	O	TraceClock
TRC_CTL	O	Trace Control

Table 14-2. Trace Port Signals (continued)

Signal Name	I/O Type	Description
TRC_DATA[15:0]	O	TraceData[15:0]

Note

The Trace Port interface signals are associated with device pins that are multiplexed with other signal functions.

14.1.3.3 Debug and Boundary Scan Access and Control

On-Chip debug resources are made available through two mechanisms:

- JTAG access via DAP and related APs
- JTAG access via Boundary Scan TAP

14.1.3.3.1 DAP

Off-chip debug tools are able to access On-Chip debug resources via the JTAG interface.

A CoreSight™ Compliant DAP architecture provides access via a DP and a collection of APs:

- SWJ-DP: Arm® CoreSight™ compliant SWJ Debug Port provides support for a JTAG interface with a 4-bit IR Note: Even though an SWJ-DP is implemented on-chip, only JTAG is supported. This device does not support SWD.
- APB-AP: Arm® CoreSight™ APB Access Port provides access to the Debug-APB address space which is the primary configuration space for On-Chip Debug resources.
- AHB-AP: Arm® CoreSight™ AHB Access Port provides access to the SoC address space, allowing visibility and control over system resources.
- Config-AP: TI Configuration AP supports access to SoC debug management registers
- Power-AP: TI Configuration AP supports reset management

14.1.3.3.1.1 Debug Subsystem Address Map

The memory map view for DAP AHB is the same as SOC memory map view seen by Cortex R5F CPU (except for R5F Core dedicated memories and peripherals).

Table 14-3 shows the APB AP address map for AM263x.

Table 14-3. APB AP Memory Map

APB PORT	Block Name	Start Address Offset	End Address Offset
APB INTERNAL PORT0	Debugss ROM Table	0x0000 0000	4KB
APB INTERNAL PORT0	Debugss CTI	0x0000 1000	4KB
APB INTERNAL PORT0	Debugss TPIU	0x0000 2000	4KB
APB EXTERNAL PORT 0	Ext Port0 ROM TABLE	0x0001 0000	4KB
APB EXTERNAL PORT 0	ATB REPLICATOR	0x0001 1000	4KB
APB EXTERNAL PORT 0	CSETB	0x0001 2000	4KB
APB EXTERNAL PORT 0	STM	0x0001 3000	4KB
APB EXTERNAL PORT 0	STM-CTI	0x0001 4000	4KB
APB EXTERNAL PORT 0	HSM CM4 CTI	0x0001 5000	4KB
APB EXTERNAL PORT 1	R5SS0 ROM Table	0x00020000	0x00020FFF
APB EXTERNAL PORT 1	R5SS0 CPU0	0x00030000	0x00030FFF
APB EXTERNAL PORT 1	R5SS0 CPU1	0x00032000	0x00032FFF
APB EXTERNAL PORT 1	R5SS0 CPU0 CTI	0x00038000	0x00038FFF
APB EXTERNAL PORT 1	R5SS0 CPU1 CTI	0x00039000	0x00039FFF
APB EXTERNAL PORT 1	R5SS0 CPU0 ETM	0x0003C000	0x0003CFFF
APB EXTERNAL PORT 1	R5SS0 CPU1 ETM	0x0003D000	0x0003DFFF
APB EXTERNAL PORT 2	R5SS1 ROM Table	0x00040000	0x00040FFF

Table 14-3. APB AP Memory Map (continued)

APB PORT	Block Name	Start Address Offset	End Address Offset
APB EXTERNAL PORT 2	R5SS1 CPU0	0x00050000	0x00050FFF
APB EXTERNAL PORT 2	R5SS1 CPU1	0x00052000	0x00052FFF
APB EXTERNAL PORT 2	R5SS1 CPU0 CTI	0x00058000	0x00058FFF
APB EXTERNAL PORT 2	R5SS1 CPU1 CTI	0x00059000	0x00059FFF
APB EXTERNAL PORT 2	R5SS1 CPU0 ETM	0x0005C000	0x0005CFFF
APB EXTERNAL PORT 2	R5SS1 CPU1 ETM	0x0005D000	0x0005DFFF

14.1.3.3.2 Boundary Scan

This device supports boundary scan using an IEEE 1149.1 compliant JTAG TAP. IEEE 1149.1 and 1149.6 Boundary Scan support are defined in device-specific BSDL files that can be found in the respective device's product folder on ti.com.

14.1.3.4 Reset Management

Reset isolation: critical configuration and trace datapaths and logic are not sensitive to warm reset.

Configuration independence: debug configuration occurs over a debug-only interconnect, separate from SoC traffic to ensure debug logic remains available even during deadlock scenarios.

Power-AP: a CoreSight™ compliant Access Port (AP) developed by TI that provides a standard interface for debug tooling to access status and control over power, reset, and clocking for the system. In AM263x device Power-AP can control the reset of the system.

14.1.3.5 Debug Cross Triggering

This device supports an Arm® CoreSight™ compliant four-channel programmable on-chip cross triggering network.

Conceptually, each channel of cross triggering can be viewed as mapping of a user-defined set of events to a user-defined set of actions, where the occurrence of any event in the set-of-events results in the generation of the set-of-actions.

The cross triggering network of AM263x is shown in [Figure 14-3](#).

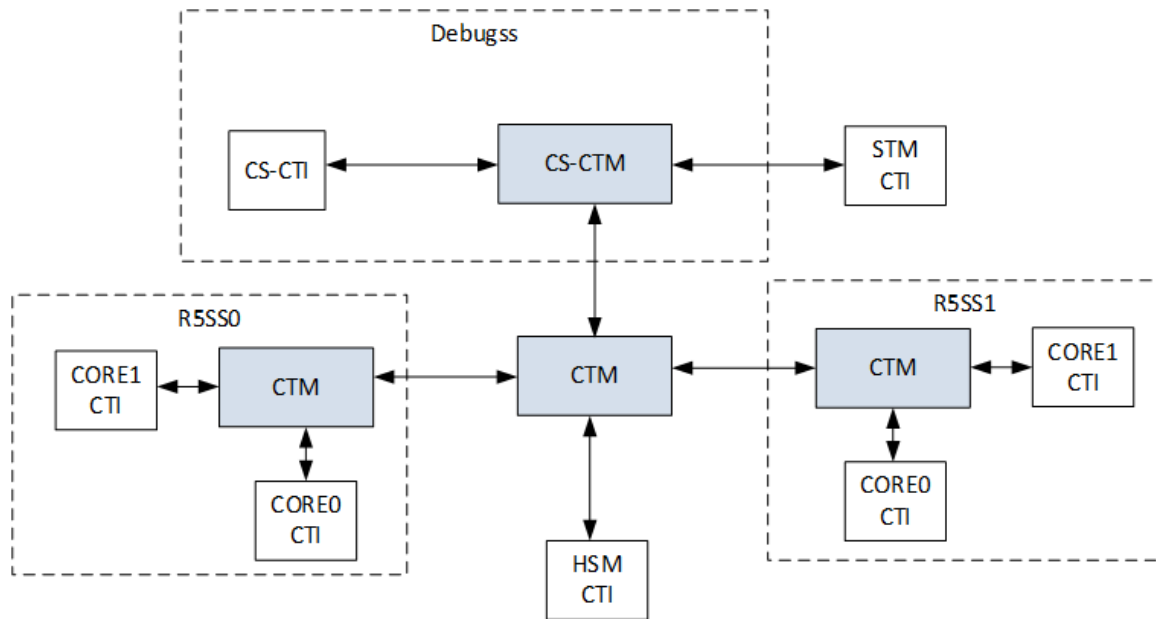

Figure 14-3. Cross Trigger Network

14.1.3.5.1 R5F CTI Trigger Connections

Table 14-4. R5F CTI Trigger Input Connections (One per R5F Core)

Trigger Input Bit	Source	Comments
[7]	Muxed VIM Interrupt sources	A mux selects which of the VIM interrupt event is routed as Trigger MSS_CTRL. R5SS*_CTI_TRIG_SEL.TRIG*[7:0] bits control the mux.
[6]	ETM: ETMTRIGGER	ETM managed Trigger. Generated internal to Cortex R5 Subsystem
[5]	CORE:COMMTX	Communications channel transmit. Generated internal to Cortex R5 Subsystem
[4]	CORE:COMMRX	Communications channel receive. Generated internal to Cortex R5 Subsystem
[3]	ETM:ETMEXTOUT[1]	ETM managed External Output Event 1. Generated internal to Cortex R5 Subsystem
[2]	ETM:ETMEXTOUT[0]	ETM managed External Output Event 0. Generated internal to Cortex R5 Subsystem
[1]	CORE: PMUIRQ	Interrupt request from performance monitoring unit. Generated internal to Cortex R5 Subsystem
[0]	CORE: DBGTRIGGER	CPU is entering the debug state (halted). Generated internal to Cortex R5 Subsystem

Table 14-5. R5F CTI Trigger Output Connections (One per R5F Core)

Trigger Output Bit	Destination	Comments
[7]	CORE:DBGRESTART	External restart request
[6]	Not Used	
[5]	Not Used	

Table 14-5. R5F CTI Trigger Output Connections (One per R5F Core) (continued)

Trigger Output Bit	Destination	Comments
[4]	Not Used	
[3]	VIM :CTI Interrupt	VIM Interrupt
[2]	ETM:EXTIN[1]	ETM External Input 1
[1]	ETM:EXTIN[0]	ETM External Input 0
[0]	CORE: EDBGREQ	External debug request

14.1.3.5.2 Cortex M4 CTI Trigger Connections**Table 14-6. M4 CTI Trigger Input Connections**

Trigger Input Bit	Source Signal	Comments
[7]	Reserved	
[6]	DWT:ETMTRIGGER[2]	DWT generated Trigger 2
[5]	DWT:ETMTRIGGER[1]	DWT generated Trigger 1
[4]	DWT:ETMTRIGGER[0]	DWT generated Trigger 0
[3]	Reserved	
[2]	Reserved	
[1]	Reserved	
[0]	CORE:HALTED	CPU Has Halted

Table 14-7. M4 CTI Trigger Output Connections

Trigger Output Bit	Destination	Comments
[7]	CORE:DBGRESTART	External restart request
[6]	Not Used	
[5]	Not Used	
[4]	Not Used	
[3]	NVIC:CTI_IRQ0	NVIC Interrupt. Refer to Processor Interrupt Map for more details
[2]	NVIC:CTI_IRQ1	NVIC Interrupt. Refer to Processor Interrupt Map for more details
[1]	Not Used	-
[0]	CORE:EDBGRQ	External Debug Request.

14.1.3.5.3 STM CTI Trigger Connections**Table 14-8. STM CTI Trigger Input Connections**

Trigger Input Bit	Source Signal	Comments
[7]	Reserved	
[6]	Reserved	
[5]	Reserved	
[4]	Reserved	
[3]	Reserved	
[2]	STM:ASYNCOUT	Alignment synchronization output. The STM asserts this signal for one clock cycle when an ASYNC-VERSION-FREQ sequence is output on the ATB interface, and the ASYNCOUT signal can be used for cross-triggering.
[1]	STM:TRIGOUTSW	The STM asserts this signal for one clock cycle when a trigger event is generated on writes to a TRIG location in the extended stimulus port registers

Table 14-8. STM CTI Trigger Input Connections (continued)

Trigger Input Bit	Source Signal	Comments
[0]	STM:TRIGOUTSPTE	The STM asserts this signal for one clock cycle when a trigger event is detected on a match using the STMSPTER.

14.1.3.5.4 Debugss CS-CTI Trigger Connections

Table 14-9. Debugss CS-CTI Trigger Input Connections

Trigger Input Bit	Source	Comments
[7]	Muxed Vim3 Interrupt inputs	Select any one of the 256 VIM3 interrupt. Configure by writing to MSS_CTRL.DBGSS_CTI_TRIG_SEL.TRIG3
[6]	Muxed Vim2 Interrupt inputs	Select any one of the 256 VIM2 interrupt. Configure by writing to MSS_CTRL.DBGSS_CTI_TRIG_SEL.TRIG2
[5]	Muxed Vim1 Interrupt inputs	Select any one of the 256 VIM1 interrupt. Configure by writing to MSS_CTRL.DBGSS_CTI_TRIG_SEL.TRIG1
[4]	Muxed Vim0 Interrupt inputs	Select any one of the 256 VIM0 interrupt. Configure by writing to MSS_CTRL.DBGSS_CTI_TRIG_SEL.TRIG0
[3]	Reserved	
[2]	Reserved	
[1]	Reserved	
[0]	PWR-AP:SYNCRUNOUT	Debugss Power AP

Table 14-10. Debugss CS-CTI Trigger Output Connections

Trigger Output Bit	Destination	Comments
[7]	Not Used	
[6]	Not Used	
[5]	Not Used	
[4]	CS-ETB: TRIGIN	Embedded Trace buffer
[3]	Not Used	
[2]	Not Used	
[1]	TPIU:FLUSHIN	Debugss TPIU
[0]	TPIU: TRIGIN	Debugss TPIU

14.1.3.6 SOC Debug and Trace

This device includes debug capabilities deployed at the system level, including:

- Software messaging trace
- Debug-aware peripherals
- Global timestamping for trace

More details for each of these capability areas can be found in the corresponding sections below.

14.1.3.6.1 Software Messaging Trace

Software messaging trace is supported on this device by an MIPI STP-V2 compliant Arm® CoreSight™ STM with supporting logic that maps initiator IDs to specific STP Major Source IDs. The following device initiators support software messaging.

Table 14-11. STM Aperture Assignment

16 MB Address Aperture of STM	Master
0	R5SS0_CORE0_AXI_W
1	R5SS0_CORE1_AXI_W
2	R5SS1_CORE0_AXI_W
3	R5SS1_CORE1_AXI_W

Table 14-11. STM Aperture Assignment (continued)

16 MB Address Aperture of STM	Master
4	HSM
5	ICSSM PRU0
6	ICSSM PRU1

14.1.3.6.2 Debug Aware Peripherals

Select peripherals support a debug feature that allows them to react to the debug state of a controlling processor. For instance, a timer peripheral that is allocated to a particular processor could be configured to stop counting when the associated processor is in the halted state. This device includes programmable support for shared peripherals that allows the developer to select the processor whose debug state a given peripheral should receive.

The Halt enable control register corresponding to the peripheral can be programmed to select which R5F CPU when halted will suspend the peripheral.

Table 14-12. Suspend Peripherals

Peripherals	Halt Enable Control Register
MCAN* [0-3]	MSS_CTRL: MCAN*_HALTEN
LIN* [0-4]	MSS_CTRL: LIN*_HALTEN
I2C* [0-3]	MSS_CTRL: I2C*_HALTEN
RTI*[0-3]	MSS_CTRL: RTI*_HALTEN
CPSW	MSS_CTRL: CPSW_HALTEN
MCRC0	MSS_CTRL: MCRC0_HALTEN
EPWM*[0-31]	CONTROLSS_CTRL: EPWM*_HALTEN
CMPSSA* [0-9]	CONTROLSS_CTRL: CMPSSA*_HALTEN
CMPSSB* [0-9]	CONTROLSS_CTRL: CMPSSB*_HALTEN
ECAP*[0-9]	CONTROLSS_CTRL: ECAP*_HALTEN
EQEP*[0-2]	CONTROLSS_CTRL: EQEP*_HALTEN

14.1.3.7 Trace Infrastructure

Trace traffic originates from a trace source, is distributed across the device using Arm® CoreSight™ compliant trace infrastructure components, and reaches one of two possible trace sinks. The trace infrastructure is shown in [Figure 14-4](#).

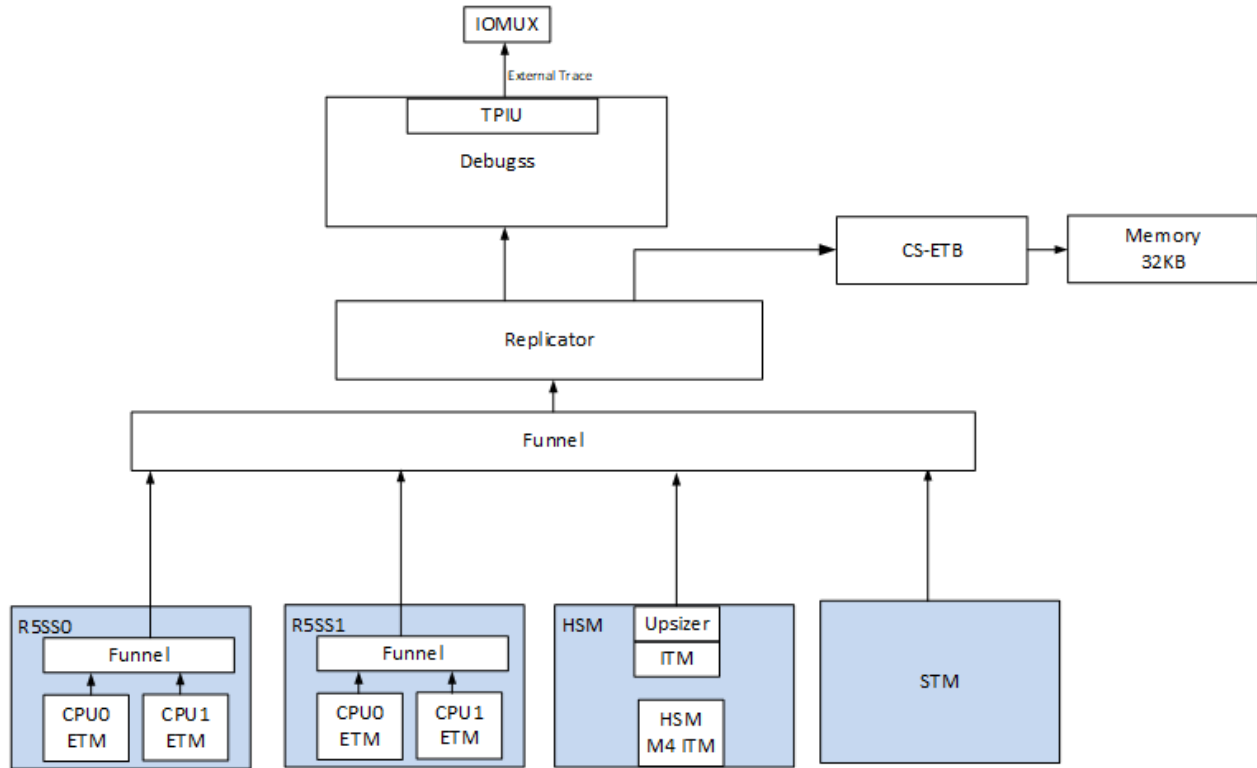

Figure 14-4. Trace Infrastructure

14.1.3.7.1 Trace Sources

The following trace sources are present in this device:

- STM
- HSM M4 ITM
- R5FSS0 Core0 ETM
- R5FSS0 Core1 ETM
- R5FSS1 Core 0 ETM
- R5FSS1 Core 1 ETM

14.1.3.7.2 Trace Distribution

Trace distribution is accomplished using standard Arm® CoreSight™ compliant trace infrastructure components:

CoreSight™ Trace Funnels (CSTF): Non-programmable CSTFs are used at points of interleaving where multiple trace sources converge and form a single stream of trace traffic. This device includes one instance of a CSTF that is deployed immediately before the TPIU.

CoreSight™ Trace Replicator (CSREP): A programmable CSREP is used as a routing device, that can be used to forward trace traffic, based on its ID, to one, both, or none of the device trace sinks. This device includes one instance of a CSTF that is deployed immediately before the TPIU to route the trace traffic to either CS-ETB or TPIU.

14.1.3.7.3 Trace Sinks

Two trace sinks are supported on this device:

Arm® CoreSight™ TPIU: TPIU supports export of trace off-chip via LVCMOS device pins (See 1.3.2.2) for capture by an external receiver.

CS-ETB Trace Buffer with 34KB of storage: CS-ETB can be setup to capture trace data until the internal buffer fills system bridge mode supports interrupt and event notification capabilities that support integration with device level CPUs and/or DMAs to support.

ADVANCE INFORMATION

Revision History



NOTE: Page numbers for previous revisions may differ from page numbers in the current version.

Changes from March 1, 2022 to August 31, 2022 (from Revision * (March 2022) to Revision A (August 2022))

	Page
• (Memory Map): Added details and footnote regarding R5FSS i-cache/d-cache memory sizes.....	24
• (INFRA1 VBUSP Interconnect Diagram): Removed ESM connection.....	43
• Added note EDMA doesn't have PrivID.....	49
• Updated LIN Integration diagram. Completed LIN# Integration table details.....	108
• Added Content of Initialization Chapter.....	135
• Removing unsupported Thermal Reset reset source option.....	196
• Updated Tightly-Coupled Memories (TCMs) section.....	251
• Updated R5FSS0 Special Features table.....	252
• Updated R5FSS1 Special Features table.....	252
• Updated Target Interfaces section.....	254
• Updated R5FSS Power section.....	254
• Updated R5FSS Clocking section.....	254
• Updated R5FSS Reset section.....	254
• Updated R5FSS ECC Support section.....	255
• Updated R5FSS Memory View section.....	256
• Updated R5FSS Interrupts section.....	256
• Updated R5FSS Boot Options section.....	256
• Updated R5FSS Core Memory ECC Events section.....	257
• Added R5FSS TCM Address Parity Error section.....	258
• Added R5FSS Lockstep Compare section.....	0
• Added R5FSS Selftest Logic section.....	275
• Update FBD from ICSS to PRUSS	291
• Update Clock Generation Diagram with PRUSS.....	348
• Added OUTPUTXBAR Input Connection Table.....	706
• (VIM Interrupt Prioritization): Note added to define VIM interrupt priority scheme.....	742
• (VIM Interrupt Prioritization): Note added with details regarding interrupt "masking" terminology.....	742
• ICSSM0_IEP_CAP_INTR5 included in ICSSM Event Map table.....	879
• Added note to UART Frame Data Format diagram.....	982
• GPMC0_CFG start address is 03B0 0000, not 0539 0000h.....	1242
• Renamed master word with "controller" in CAN chapter.....	1343
• Updated LIN Integration diagram. Completed LIN# Integration table details.....	1394
• Added On-Chip Debug chapter.....	1526

ADVANCE INFORMATION

This page intentionally left blank.

IMPORTANT NOTICE AND DISCLAIMER

TI PROVIDES TECHNICAL AND RELIABILITY DATA (INCLUDING DATA SHEETS), DESIGN RESOURCES (INCLUDING REFERENCE DESIGNS), APPLICATION OR OTHER DESIGN ADVICE, WEB TOOLS, SAFETY INFORMATION, AND OTHER RESOURCES "AS IS" AND WITH ALL FAULTS, AND DISCLAIMS ALL WARRANTIES, EXPRESS AND IMPLIED, INCLUDING WITHOUT LIMITATION ANY IMPLIED WARRANTIES OF MERCHANTABILITY, FITNESS FOR A PARTICULAR PURPOSE OR NON-INFRINGEMENT OF THIRD PARTY INTELLECTUAL PROPERTY RIGHTS.

These resources are intended for skilled developers designing with TI products. You are solely responsible for (1) selecting the appropriate TI products for your application, (2) designing, validating and testing your application, and (3) ensuring your application meets applicable standards, and any other safety, security, regulatory or other requirements.

These resources are subject to change without notice. TI grants you permission to use these resources only for development of an application that uses the TI products described in the resource. Other reproduction and display of these resources is prohibited. No license is granted to any other TI intellectual property right or to any third party intellectual property right. TI disclaims responsibility for, and you will fully indemnify TI and its representatives against, any claims, damages, costs, losses, and liabilities arising out of your use of these resources.

TI's products are provided subject to [TI's Terms of Sale](#) or other applicable terms available either on ti.com or provided in conjunction with such TI products. TI's provision of these resources does not expand or otherwise alter TI's applicable warranties or warranty disclaimers for TI products.

TI objects to and rejects any additional or different terms you may have proposed.

Mailing Address: Texas Instruments, Post Office Box 655303, Dallas, Texas 75265
Copyright © 2022, Texas Instruments Incorporated