

AWR1843 Radar Board Powered by TPS65313-Q1 Wide VIN Safety PMIC and TPS65653-Q1

ABSTRACT

This application report provides detailed design guidelines for designing a functional safety, LDO-free radar sensor module using TI's AWR1843 (single-chip FMCW radar sensor), TPS65313-Q1 (Wide VIN, ASIL-C safety PMIC) and TPS65653-Q1 (Dual BUCK with diagnostics capabilities). This application guide also describes the challenges faced while designing noise sensitive radar sensor modules along with various test results to prove its performance. This radar sensor module design could be used in many different automotive applications like blind spot detection (BSD), cross traffic alert (CTA), lane change assist (LCA), traffic jam assist (TJA) and In-cabin applications. This sensor module includes two controller area networking with flexible data rate (CAN-FD) transceivers to transmit the radar data over vehicle CAN bus.

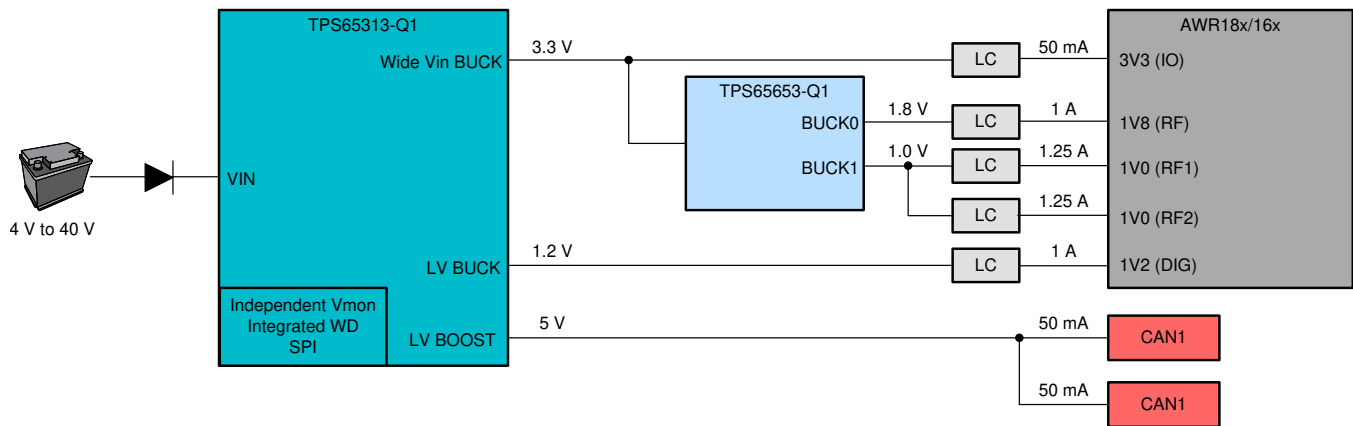

Figure 1. High Level Block Diagram

NOTE: The LC filter on the 3.3-V rail is optional and the load currents specified are approximate numbers only.

Key Devices:

TPS65313-Q1, TPS65653-Q1, AWR1843, AWR1642, TCAN1042, and TCAN1043.

Contents

1	Introduction	4
2	Radar Board Overview	5
3	Hardware, Software, and Testing Requirements	13
4	Testing and Results	14
5	Schematics	29
6	PCB Layer	34
7	Bill of Materials	37
8	References	46

List of Figures

1	High Level Block Diagram	1
2	System Level Detailed Block Diagram	5
3	PCB Top Side	7
4	PCB Bottom Side	7
5	Power Supply Solution Size Marked in Yellow Box	7
6	Regulators Start-up Along With AWR Reset Signal (TPS65313 NRES)	9
7	Regulators Shut-down Along With AWR Reset Signal (TPS65313 NRES)	9
8	1.0-V and 1.8-V RF Power Supply Filter Generic Schematics	12
9	A Typical 50% Duty Chirp Profile (Profile-1) Settings	13
10	1.0-V RF2 Supply Spectrum Analyzer Plot With AWR Active and No Chirps	15
11	1.8-V RF Supply Spectrum Analyzer Plot With AWR Active and No Chirps	15
12	1.0-V RF1 Supply Current During Chirping	15
13	1.0-V RF2 Supply Current During Chirping	15
14	1.8-V RF Supply Current During Chirping	15
15	1.0-V RF1 Supply Voltage Transient During Chirping.....	16
16	1.0-V RF2 Supply Voltage Transient During Chirping.....	16
17	1.8-V RF Supply Voltage Transient During Chirping	16
18	1.2-V Supply Voltage Transient During Chirping.....	17
19	3.3-V Supply Voltage Transient During Chirping.....	17
20	1D-FFT Plot With Metal Plate Kept In Front of Antenna With 0-Hz Frequency Slope and With LC Filter	18
21	1D-FFT Plot With Metal Plate Kept In Front of Antenna With 0-Hz Frequency Slope and Without LC Filter	18
22	CW Capture Settings	19
23	1D-FFT Plot In CW Mode With Metal Plate Kept In Front of Antenna With 0-Hz Frequency Slope and With LC Filter	19
24	1D-FFT Plot In CW Mode With Metal Plate Kept In Front of Antenna With 0-Hz Frequency Slope and Without LC Filter	19
25	Anechoic Chamber Test Setup.....	20
26	1D-FFT Plot With 0-Hz Frequency Slope-idle Channel	21
27	1D-FFT Plot With 2 Inch Trihedral Corner Reflector Placed at 5 Meter Distance From Antenna	21
28	1D-FFT Plot Without 2 Inch Trihedral Corner Reflector Placed at 5 Meter Distance From Antenna	22
29	Frequency vs Time Linearity Plot for Chirp Profile-1	22
30	Filtered Frequency Error Plot for Chirp Profile-1	23
31	Frequency vs Time Linearity Plot for Chirp Profile-1 With Negative Frequency Slope	23
32	Filtered Frequency Error Plot for Chirp Profile-1 With Negative Frequency Slope	24
33	TPS65313-Q1 BUCK1 3.3-V Load Transient	24
34	TPS65313-Q1 BUCK2 1.2-V Load Transient	24
35	TPS65313-Q1 BOOST 5.0-V Load Transient	24
36	TPS65653-Q1 BUCK0 1.8-V Load Transient	24
37	TPS65653-Q1 BUCK1 1.0-V Load Transient	24
38	TPS65313-Q1 BUCK1 3.3-V Gain and Phase Plot	25
39	TPS65313-Q1 BUCK2 1.2-V Gain and Phase Plot.....	26
40	TPS65313-Q1 BOOST 5.0-V Gain and Phase Plot	26
41	TPS65313-Q1 BUCK0 1.8-V Gain and Phase Plot	26
42	TPS65313-Q1 BUCK1 1.0-V Gain and Phase Plot	27
43	25% Duty Chirping With 2-Tx On	27
44	50% Duty Chirping With 2-Tx On	27
45	TPS65313-Q1 Device Thermal Result With Fixed DC Load	28
46	TPS65653-Q1 Device Thermal Result With Fixed DC Load	28
47	TPS65313-Q1 Schematics	29

48	TPS65653-Q1 Schematics	29
49	AWR1843 Schematics	30
50	Decoupling Caps and Analog Supply Filters	31
51	CAN Interface	31
52	Power RST LEDs	32
53	Connectors	32
54	XDS interface	33
55	PCB Top Layer	34
56	PCB Inner Layer-1	34
57	PCB Inner Layer-2	35
58	PCB Inner Layer-3	35
59	PCB Inner Layer-4	36
60	PCB Bottom Layer	37

List of Tables

1	High Level System Specifications	4
2	AWR1843 Recommended Operating Supply	8
3	AWR1843 Peak Current Specification.....	10
4	AWR Average Power Numbers	10
5	AWR1843 Ripple Specification	11
6	1.0-V RF1 Supply Ripple Measurement Summary	14
7	1.0-V RF2 Supply Ripple Measurement Summary	14
8	1.8-V RF Supply Ripple Measurement Summary	14
9	Thermal Measurements Summary	27
10	Thermal Measurements for Both ICs	28
11	Radar Board Bill of Materials	37

Trademarks

ARM, Cortex are registered trademarks of ARM Holdings.
 RO4835, LoPro are registered trademarks of Rogers Corporation.

1 Introduction

Radar sensors are a requirement for many automotive safety systems. These radar sensor modules are tiny and often contained in a small plastic housing which comes with demanding thermal performance. Due to the increasing push towards autonomous driving, demand for a fully compliant ISO 26262 functional safety capable radar module is increasing. This design addresses these concerns by combining a single-chip, 76- to 81-GHz automotive radar sensor with a wide VIN functional safety PMIC and CAN-FD PHY. All of these functions are contained on a small circuit board. The only two connections that the system requires are the battery power (12 V-typical) and CAN-FD out.

The wide VIN safety PMIC, TPS65313-Q1, BUCK1 DC-DC regulator converts 12-V supply input to a 3.3-V output. Low VIN BUCK2 DC-DC regulator of TPS65313-Q1 PMIC takes this 3.3-V input and generated 1.2-V supply. Low VIN BOOST DC-DC regulator of TPS65313-Q1 PMIC takes this 3.3-V input and generated 5-V supply for CAN transceivers.

TPS65653-Q1 has dual Low VIN, 4-MHz, DC-DC regulators and generates low noise 1.0-V and 1.8-V outputs from 3.3-V input. These Low noise and high bandwidth DC-DC regulators provide clean input supply to noise sensitive AWR 1.0-V and 1.8-V RF rails with a fast load transient performance. High switching frequency of these DC-DC regulators reduces the solution size of external LC filters, saving cost and board space.

The radar section of this design utilizes a printed-circuit-board (PCB) etched antenna with three transmit elements and four receive elements. By using this antenna, a modulated chirp is transmitted and reflections are sampled into the onboard digital signal processor (DSP). With this information, the sensor can record distance, angle, and velocity measurements from objects within the antenna field of view. The design offers a feature to write out the object data to a central electronic control unit (ECU) on the CAN-FD bus at a rate of 5-Mb/s.

Table 1. High Level System Specifications

Parameter		MIN	TYP	MAX	UNIT
V _{IN}	Supply Voltage ⁽¹⁾	6	12	18	V
P _{TOTAL}	Total Power Consumption	-	2.6	-	W
CAN-FD	Data Rate	-	-	5	Mb/s
I _{OFF_STATE}	Off state battery leakage current		20		μA
ASIL	Safety Support			ASIL-C	N/A

⁽¹⁾ TPS65313-Q1 Device Operation outside this range is possible; refer to [SLDS222](#) for more details.

2 Radar Board Overview

2.1 Detailed Block Diagram

Figure 2 shows the detailed block diagram of the board along with necessary monitorings to realize a functional safety supported AWR1843 Radar board powered by TPS65313-Q1 Wide VIN safety PMIC.

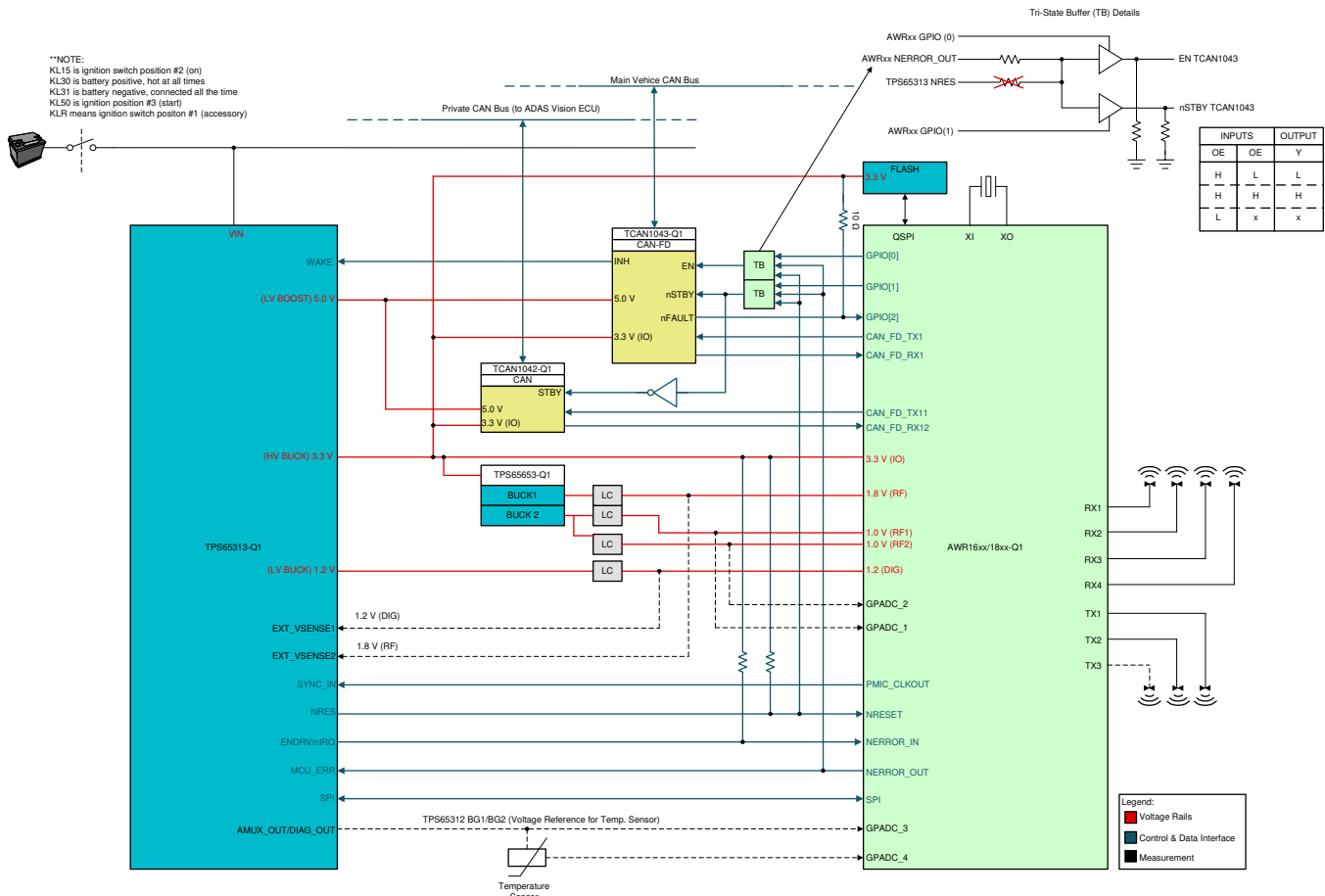

Figure 2. System Level Detailed Block Diagram

Note: This diagram is just one typical example block diagram according to this radar board schematics and there may be other implementations possible. Customers need to verify and validate on their board to make sure that it works according to their requirements.

2.2 Highlighted Products

This application board uses the following TI products:

- AWR1843:

This integrated, single-chip frequency-modulated continuous wave (FMCW) radar sensor is capable of operating in the 76-GHz to 81-GHz band. The device is built with TI's low-power 45-nm RFCMOS process and enables unprecedented levels of integration in an extremely-small form factor (SFF). The AWR1843 is an ideal solution for low-power, self-monitored, ultra-accurate radar systems in the automotive space. AWR1843 has four receivers and three transmitters with integrated RF, analog and digital subsystem to deliver low power in an SFF for ultra-short-range radar (USRR) and short-range radar (SRR) applications. The device is based on closed-loop phase-locked-loop (PLL) architecture for precise and linear chirp synthesis. The device includes a built-in radio processor (BIST) for RF calibration and safety monitoring. Based on complex baseband architecture, the sensor device supports an intermediate frequency (IF) bandwidth of 5-MHz with reconfigurable output sampling rates. Integration of an ARM® Cortex®-R4F processor and

Texas Instruments C674x DSP (fixed and floating point), along with 2 MB of on-chip RAM, enables high level algorithm development.

- **TPS65313-Q1:**
The TPS65313-Q1 device is a power management IC (PMIC) that meets the requirements of MCU controlled or DSP-controlled automotive, industrial, machinery, or transportation systems. With the integration of commonly used features, the device helps reduce board space and system cost. The device includes one wide-VIN synchronous buck regulator (BUCK1) combined with one low-voltage (LV) buck regulator (BUCK2) and one boost converter (BOOST), which are powered from the wide-VIN buck regulator (BUCK1). The device features a low quiescent current in the OFF state to reduce current consumption in case the system is permanently connected to the supply. All outputs have Independent voltage monitoring with diagnostics and protected against overvoltage, overload, and over temperature conditions. TPS65313-Q1 PMIC Supports system-level functional safety requirements up to ASIL-C (ISO 26262) and SIL-2 (IEC 61508). TPS65313-Q1 PMIC has Integrated adaptively randomized spread spectrum (ARSS) modulation for improved EMC performance and meets CISPR-25 class-5 standard.
- **TPS65653-Q1:**
This automotive-qualified power device is optimized for radar applications with a dual high-current, low noise buck converters. The high switching frequency of up to 4-MHz allows the use of small inductors and small 2nd state LC filters and improves system performance and reduces solution size. The device offers an I²C-compatible serial interface for device configuration and diagnostics. Regulators have built in short circuit protection, overload protection and output voltage UV/OV monitoring. TPS65653-Q1 also offers internal or external spread-spectrum mode for EMI reduction.
- **TCAN1043-Q1:**
The TCAN1043xx-Q1 meets the physical layer requirements of the ISO 11898–2 (2016) High Speed Controller Area Network (CAN) specification providing an interface between the CAN bus and the CAN protocol controller. These devices support both classical CAN and CAN FD up to 2 megabits per second (Mbps). The TCAN1043xx-Q1 allows for system-level reductions in battery current consumption by selectively enabling (through the INH output pin) the various power supplies that may be present on a node. This allows an ultra-low-current sleep state in which power is gated to all system components except for the TCAN1043xx-Q1, which remains in a low-power state monitoring the CAN bus.

2.3 Design Considerations

2.3.1 PCB and Form Factor

This reference design is not intended to fit any particular form-factor. End equipment form factor PCB size is around 50-mm x 55-mm and contains wide VIN PMIC, input revers polarity diode, ESD diode, EMI filter, low voltage PMIC, AWR1843, antennas, flash, 1 CAN-FD, 1 CAN-FD with wake function. The board also contains additional circuit blocks and connectors which are necessary for the debug, data capture and not necessary for the final end equipment and this section of the board is excluded from form factor solution size. [Figure 3](#) and [Figure 4](#) show the top view and bottom view of the PCB with end equipment form factor marked in the yellow box. The PCB diagrams shows that the solution size can still be reduced if the design goal is to have a smaller PCB size. [Figure 5](#) shows the power supply solution size containing TPS65313-Q1, TPS65653-Q1, and related external components

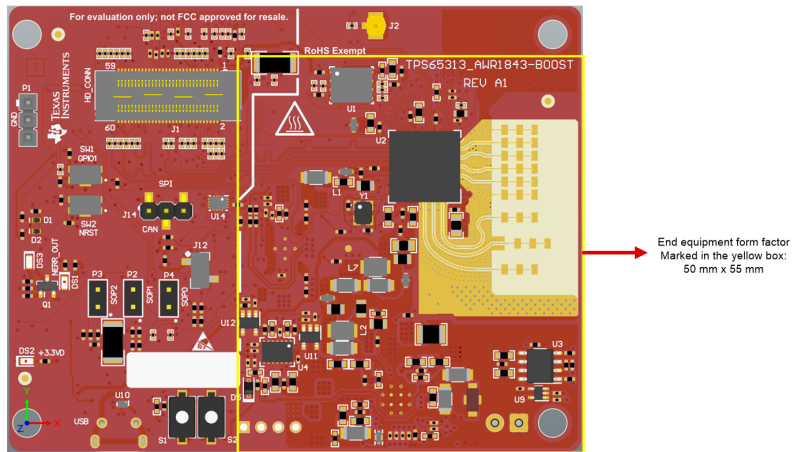

Figure 3. PCB Top Side

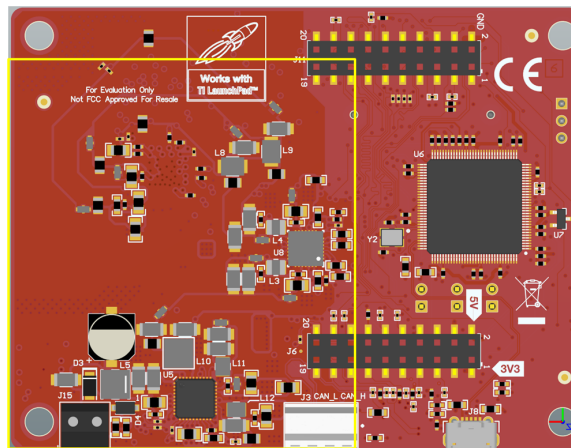

Figure 4. PCB Bottom Side

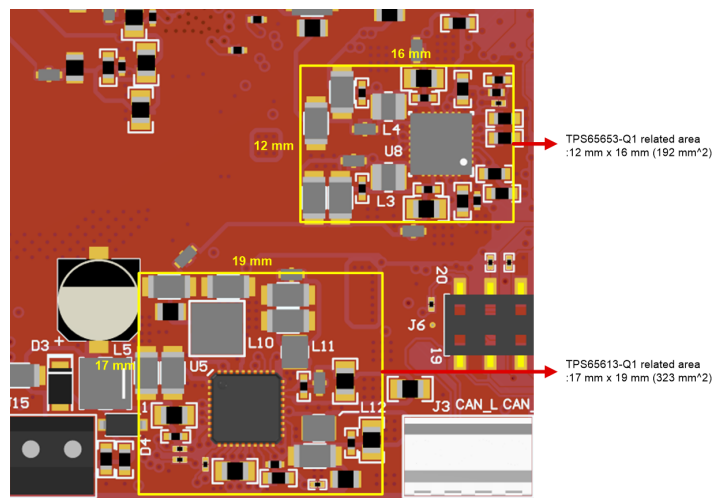

Figure 5. Power Supply Solution Size Marked in Yellow Box

2.3.2 Power Supply Topology

As [Figure 2](#) shows, the radar sensor reference design is intended to connect directly to the vehicle battery. The voltages required for the design are:

- 3.3-V for AWR1843 I/O: TPS65313-Q1 Wide VIN BUCK1 takes battery supply (12 V-typical) and generates this rail and this rail is also used as pre-regulator supply for other low voltage DC-DC regulators.
- 1.2-V for AWR1843 digital and SRAM: TPS65313-Q1 Low VIN BUCK2 generates this supply from 3.3-V input.
- 1.8-V for AWR1843 analog, RF, VCO, and CMOS: TPS65653-Q1 BUCK0 generates this supply from 3.3-V input.
- 1-V for AWR1843 analog and RF: TPS65653-Q1 BUCK1 generates this supply from 3.3-V input.
- 5-V for CAN-FD PHY: TPS65313-Q1 Low VIN BOOST generates this supply from 3.3-V input.

2.3.3 AWR1843 Power Supply Requirements

2.3.3.1 Recommended Supply Voltage Requirements

[Table 2](#) provides the recommended supply voltage range specifications for different AWR1843 supply rails. In case that the application uses internal LDO on 1.0-V/1.3-V RF rail, the external supply voltage on this pin should be 1.3-V. If an internal LDO is not used (or bypassed), external supply voltage on this pin should be 1.0-V. Often internal LDO is not used as it increases AWR internal power dissipation. No special power supply sequencing is needed, but all the input supply rails should be settled before releasing the Reset/ power good signal to the AWR device. [Figure 6](#) and [Figure 7](#) shows this design's typical power supply start-up and shut-down behavior respectively.

Table 2. AWR1843 Recommended Operating Supply

		MIN	NOM	MAX	UNIT
VDDIN	1.2-V digital power supply	1.14	1.2	1.32	V
VIN_SRAM	1.2-V power rail for internal SRAM	1.14	1.2	1.32	V
VNWA	1.2-V power rail for SRAM array back bias	1.14	1.2	1.32	V
VIOIN	I/O supply (3.3-V or 1.8-V): All CMOS I/Os would operate on this supply.	3.15	3.3	3.45	V
		1.71	1.8	1.89	V
VIOIN_18	1.8-V supply for CMOS IO	1.71	1.8	1.9	V
VIN_18CLK	1.8-V supply for clock module	1.71	1.8	1.9	V
VIOIN_18DIFF	1.8-V supply for LVDS port	1.71	1.8	1.9	V
VIN_13RF1	1.3-V Analog and RF supply. VIN_13RF1 and VIN_13RF2 could be shorted on the board	1.23	1.3	1.36	V
VIN_13RF2					V
VIN_13RF1 (1-V Internal LDO bypass mode)		0.95	1	1.05	V
VIN_13RF2 (1-V Internal LDO bypass mode)					
VIN18BB	1.8-V Analog baseband power supply	1.71	1.8	1.9	V
VIN-18VCO	1.8-V RF VCO supply	1.71	1.8	1.9	V

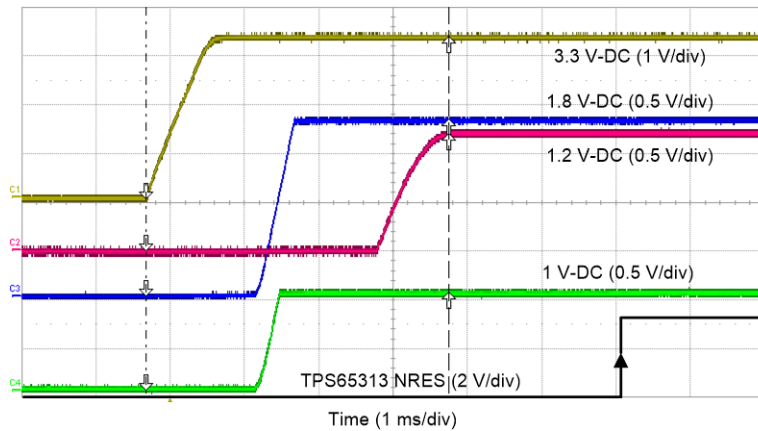

Figure 6. Regulators Start-up Along With AWR Reset Signal (TPS65313 NRES)

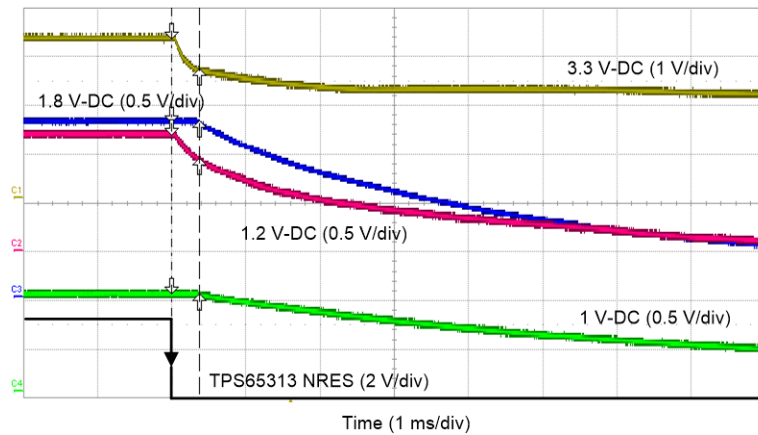

Figure 7. Regulators Shut-down Along With AWR Reset Signal (TPS65313 NRES)

2.3.3.2 Input Supply Current Requirements

Table 3 provides the peak supply current specifications and Table 4 provides the average power numbers. The typical supply currents and the average power depends on the application software and chirp configuration.

Table 3. AWR1843 Peak Current Specification

PARAMETER	SUPPLY NAME	DESCRIPTION	MIN	TYP	MAX	UNIT
Current consumption	VDDIN, VIN_SRAM, VNWA	Total current drawn by all nodes driven by 1.2-V rail.			1000	mA
	VIN_13RF1, VIN_13RF2	Total current drawn by all nodes driven by 1.3-V or 1.0-V rail (2 TX, 4 RX simultaneously) ⁽¹⁾ .			2000	
	VIOIN_18, VIN_18CLK, VIOIN_18DIFF, VIN_18BB, VIN_18VCO	Total current drawn by all nodes driven by 1.8-V rail.			850	
	VIOIN	Total current drawn by all nodes driven by 3.3-V rail.			50	

⁽¹⁾ 3 Transmitters can be simultaneously deployed only in AWR1243P and AWR1843 devices with 1V/ LDO bypass and PA LDO disable mode. In this mode 1 V supply needs to be fed on the VOUT PA pin. In this case the peak 1 V supply current goes up to 2500 mA.

Table 4. AWR Average Power Numbers

PARAMETERS	CONDITION		DESCRIPTION	MIN	TYP	MAX	UNIT	
Average power consumption	1.0 V internal LDO bypass mode	25% Duty Cycle	1TX, 4RX	Use Case: Low power mode, 3.2 MSps complex transceiver, 25-ms frame time, 128 chirps, 128 samples/chirp, 8- μ s interchirp time (25% duty cycle), DSP active.		1.3	W	
			2TX, 4RX			1.38		
		50% Duty Cycle	1TX, 4RX			1.77		
			2TX, 4RX			1.92		
	1.3 V internal LDO enabled mode	25% Duty Cycle	1TX, 4RX	Use Case: Low power mode, 3.2 MSps complex transceiver, 25-ms frame time, 128 chirps, 128 samples/chirp, 8- μ s interchirp time (25% duty cycle), DSP active		1.4		
			2TX, 4RX			1.48		
		50% Duty Cycle	1TX, 4RX		Use Case: Low power mode, 3.2 MSps complex transceiver, 25-ms frame time, 256 chirps, 128 samples/chirp, 8- μ s interchirp time (50% duty cycle), DSP active			1.94
			2TX, 4RX					2.14

2.3.3.3 Input Supply Ripple Requirements

1.0-V RF and 1.8-V RF rails have very tight ripple specifications as ripple noise on these two rails affect the RF performance. Ripple on 3.3-V and 1.2-V rails do not directly affect the RF performance, but system level noise coupling could affect the RF performance and hence it is necessary to minimize the ripple on these rails as well. Switching regulators have fundamental ripple noise at switching frequency and this needs to be reduced. Table provides the AWR device ripple noise specification. This ripple specification assumes a -105 dBc target spur level. If a higher spur can be tolerated based on the system requirements then the ripple specifications can be relaxed. There is a dB-to-dB correlation between supply ripple and spur level (For example: 1 dB increase in supply ripple will result in 1 dB increase in spur level)

Table 5. AWR1843 Ripple Specification

Frequency (KHz)	RF RAIL		VCO/IF RAIL
	1.0-V (INTERNAL LDO BYPASS) (μV_{RMS})	1.3-V (μV_{RMS})	1.8-V (μV_{RMS})
137.5	7	648	83
275	5	76	21
550	3	22	11
1100	2	4	6
2200	11	82	13
4200	13	93	19
6600	22	117	29

2.3.3.4 Power Supply Design Challenges and Care About for TI Radar Power Supply

Power Supply design challenges for TI radar processors are described below and these are addressed in this design.

1. 1.0-V/1.3-V RF and 1.8 V RF rails have very tight ripple specifications in (μV range) and it is very challenging to meet such a low ripple specifications for switching regulators.
2. Traditionally, LDO's are used on RF rails, but LDO solution suffer from poor thermal performance and it increases cost.
3. Low cost LC filter is used between switching regulators and AWR supply rails to filter the ripple. LC filter should be carefully selected as large inductance will cause load transient settling or ringing issues and also increased voltage drop across them. Smaller inductance won't provide enough filtering performance.
4. All the power rails should be within $\pm 5\%$ (except 1.2-V over voltage) of nominal voltage level and increased ringing will result in violation of specification.
5. All the ringing should ideally settle very quickly (before ADC start-time) to avoid spurs related to power supply settling noise
6. Higher regulator switching frequency helps to reduce the LC filter size and also increases regulator bandwidth to minimize the undershoot or overshoot during the load transient. All TI Radar PMIC's supplying the RF rails use 4-MHz switching frequency.
7. LC filter is placed outside the switching regulator regulation loop. L (ferrite bead) is placed close to the regulator output and C of this LC filter includes the decoupling capacitors of the AWR supply pins.
8. In case of USRR, SRR, and some MRR applications, PCB size is very limited and hence it is necessary to have a very small power management solution size.
9. Increased board temperature will affect the AWR RF performance and hence it is necessary to reduce the effect of the board temperature rise due to the PMIC and regulators heating. Also some of the radar applications have plastic housing and thermal management becomes very critical.
10. System level safety requirements for radar sensors are increasing and hence it is necessary to have PMIC's which meet system level safety goals (ASIL-B, ASIL-C at PMIC level).

2.3.4 AWR Input Supply Second Stage LC Filter Design

2.3.4.1 1.0-V RF and 1.8-V RF Rail LC Filter Design

Figure 8 shows the 1.0-V and 1.8-V RF power supply filtering generic schematics. Refer to the schematic diagram and part list section for the detailed schematics diagrams and components used.

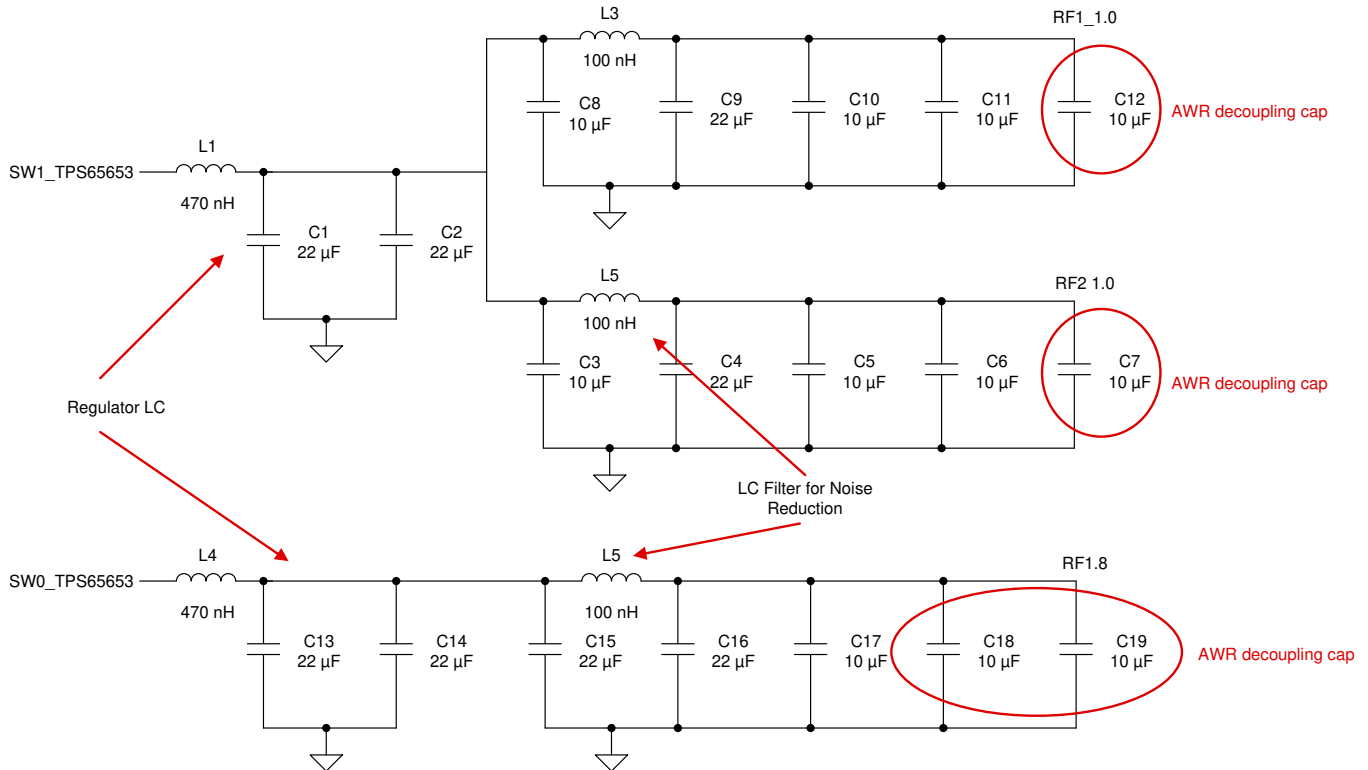

Figure 8. 1.0-V and 1.8-V RF Power Supply Filter Generic Schematics

- The regulators are switching at 4-MHz (PWM mode) and uses 470-nH inductor and 2 x 22-µF output capacitors to get good noise performance and phase margin. Shielded inductor with low DCR is recommended.
- In the default configuration, 100-nH inductor (NLCV32T-R10M-EFRD) was used for 2nd stage LC filter (L2, L3 and L5 in Figure 8). Unless otherwise mentioned, 100-nH inductor is used for any measurement. Performance was also verified with MPZ2012S101A ferrite bead and it could be used instead of 100-nH to save cost and space.
- C of this LC filter includes the decoupling capacitors of the AWR supply pins. Additional filter capacitor could help to improve the filtering performance and TI recommends to add a placeholder for at least one additional 22-µF capacitor after the ferrite bead to improve the noise filtering and load transient performance. Based on the performance evaluation on customer boards, if this capacitor is not needed, then it can be removed. The amount of ripple noise and load transient noise that can be tolerated depends on the application and use case.
- Placing the LC filter (ferrite bead and one 22-µF filter capacitor after the ferrite bead) close to the regulator helps to filter the noise close to the source and this could potentially reduce the noise in the area close to the AWR on the PCB. If the LC filter is placed close to AWR, switching regulator noise is spread in to the PCB and hence has a higher chance of coupling.
- On 1.0-V rail, LC filter is split into two paths (RF1_1 and RF1_2) to decouple them from each other for improved noise performance and also reduce IR drop across the second stage inductor.

2.3.4.2 1.2-V and 3.3-V Rail Second Stage LC Filter Design

1.2-V and 3.3-V rails do not have stringent noise specifications as ripple noise on these rails do not affect RF performance. However, there is a possibility of noise coupling at system level which could affect the RF performance. So, ferrite bead or small inductor is used between the switching regulator output and AWR supply rails. Refer to the schematic diagram and partlist section for detailed schematics diagrams and components used.

2.3.5 Antenna Design and PCB Material

This radar application board includes onboard-etched antennas for the four receivers and three transmitters that enable tracking multiple objects with their distance and angle information. This antenna design enables estimation of distance and elevation angle that enable subject detection in a three-dimensional plane.

A normal FR4 board material results in unacceptable losses for the 77-GHz antenna included in the top two layers of this design. This design uses ceramic material from Rogers Corporation to meet the dielectric requirements. Additionally, the RO4835® LoPro® series of laminates from Rogers Corporation uses a reverse-treated foil for a smoother metal. This selection of material results in a lower variation in etched-feature dimensions. With wavelengths of less than 4 mm, these tolerances are very important.

3 Hardware, Software, and Testing Requirements

This radar application board is an easy-to-use evaluation board for the AWR1843 mmWave sensing Device. For these tests, mmWave Studio is used to configure the Radar board and obtain the 1D FFT plots. The raw radar data is captured using the DCA1000 capture card. Refer to DCA1000 user's guide (SPRUIJ4) and mmWave software development kit (SDK).

Different application software packages (such as: BSD, LCA, and TJA) can operate on this board and connects to a visualization tool running on a PC connected to the EVM over USB. For most of the testing, mmWave Studio is used with a typical chirp profile shown in Figure 9, unless otherwise specified. Also, input supply voltage is set to 12.5-V for all the measurements.

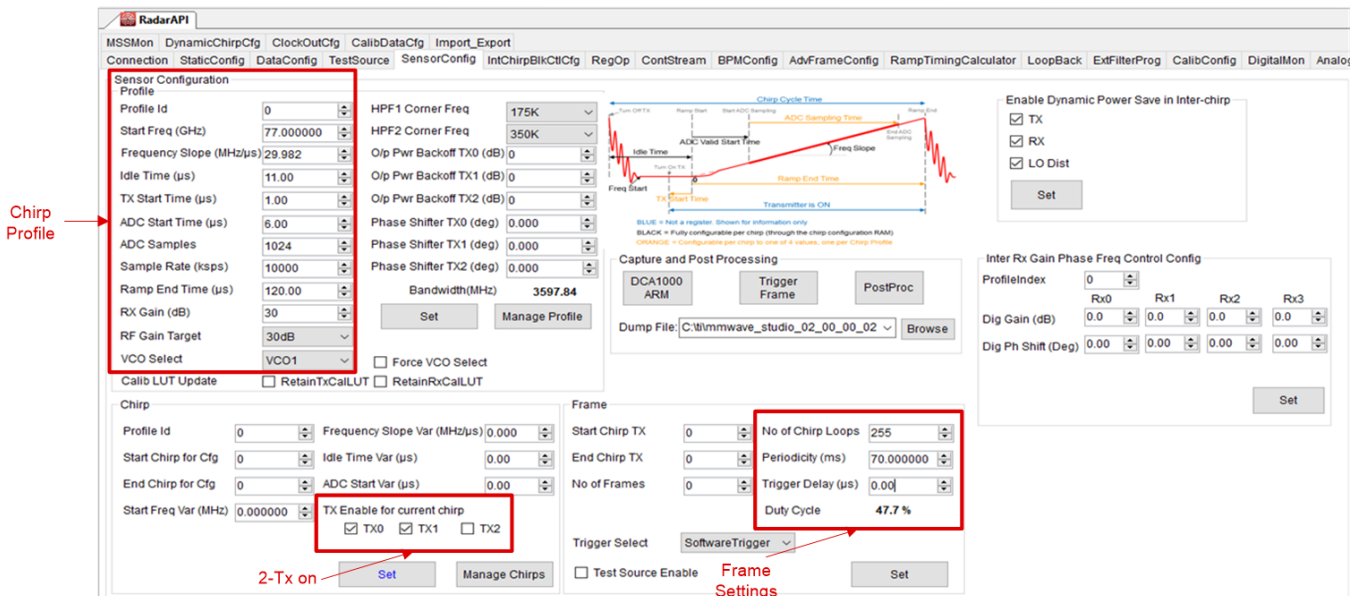

Figure 9. A Typical 50% Duty Chirp Profile (Profile-1) Settings

4 Testing and Results

4.1 1.0-V and 1.8-V RF Supply Rail Ripple Measurement Results

AWR1843 RF input supply ripple is measured using a spectrum analyzer for different chirp conditions and also for AWR max load current specifications. Measurements are done directly across the decoupling capacitors placed close to the AWR supply pins on the bottom side. [Table 6](#) to [Table 8](#) provided the summary of ripple measurements and results are within the AWR1843 ripple specifications. [Figure 10](#) and [Figure 11](#) shows the spectrum analyzer plots along with the spectrum analyzer measurement settings.

Table 6. 1.0-V RF1 Supply Ripple Measurement Summary

Frequency	Ripple on RF1_1V rail (μ Vrms)				
	AWR Active - No chirp	AWR Active - 25% chirp	AWR Active - 50% chirp	AWR in Reset- Full load-passive ⁽¹⁾	AWR1843 Data Sheet Ripple Specification
2.2-MHz	2.35	4.27	4.80	5.24	11
4-MHz	3.61	3.48	3.68	4.45	13
4.4-MHz	1.74	1.92	2.05	6.05	13
8-MHz	2.14	2.43	2.48	5.99	22

⁽¹⁾ Resistive load soldered on AWR decoupling capacitors to emulate AWR maximum load currents as specified in [Table 3](#).

Table 7. 1.0-V RF2 Supply Ripple Measurement Summary

Frequency	Ripple on RF2_1V rail (μ Vrms)				
	AWR Active - No chirp	AWR Active - 25% chirp	AWR Active - 50% chirp	AWR in Reset- Full load-passive ⁽¹⁾	AWR1843 Data Sheet Ripple Specification
2.2-MHz	3.24	5.56	5.90	7.24	11
4-MHz	3.83	4.86	5.43	7.34	13
4.4-MHz	2.24	5.21	6.07	8.63	13
8-MHz	2.00	3.56	4.63	3.29	22

⁽¹⁾ Resistive load soldered on AWR decoupling capacitors to emulate AWR maximum load currents as specified in [Table 3](#).

Table 8. 1.8-V RF Supply Ripple Measurement Summary

Frequency	Ripple on RF 1.8 V rail (μ Vrms)				
	AWR Active - No chirp	AWR Active - 25% chirp	AWR Active - 50% chirp	AWR in Reset- Full load-passive ⁽¹⁾	AWR1843 Data Sheet Ripple Specification
2.2-MHz	7.50	6.03	6.07	6.64	13
4-MHz	4.42	4.84	4.69	6.74	19
4.4-MHz	1.88	2.51	2.51	3.71	19
8-MHz	2.51	3.76	3.98	3.55	29

⁽¹⁾ Resistive load soldered on AWR decoupling capacitors to emulate AWR maximum load currents as specified in [Table 3](#).

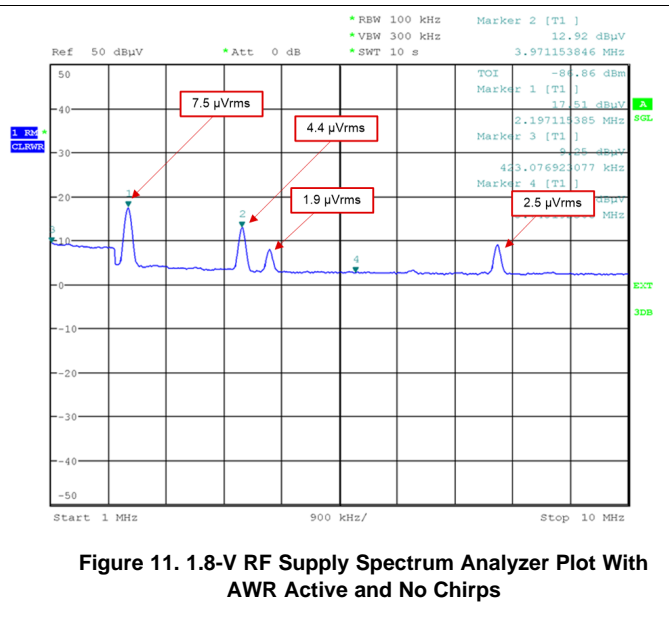
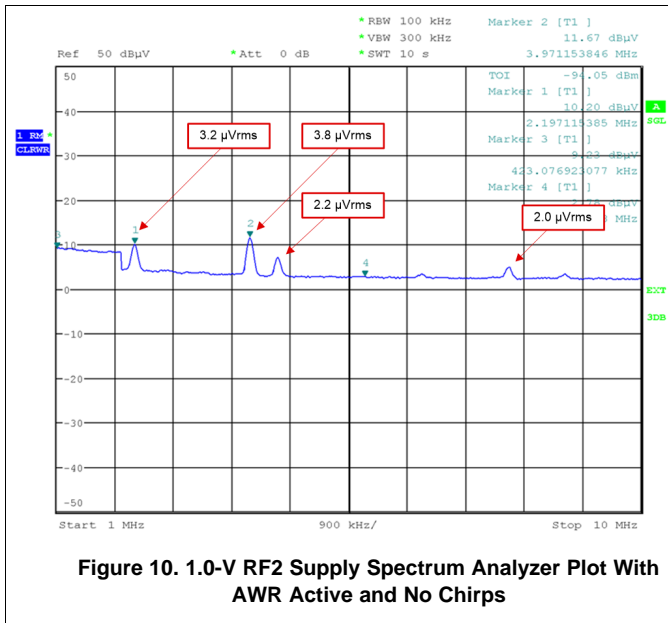

4.2 Load Transient Measurement Results

A typical chirp profile-1 shown in Figure 9 is used for load transient testing. Measurements are done directly across the decoupling capacitors placed close to the AWR supply pins on the bottom side using oscilloscope.

4.2.1 1.0-V and 1.8-V RF Supply Transient Measurement Results

4.2.1.1 1.0-V and 1.8-V RF Supply Current Measurement During Chirping

During the AWR chirp operation, there is fast load transients on 1.0-V and 1.8-V supply rails. Figure 12 to Figure 14 shows the load transient current on these supply rails. Load current measurement is done by removing the second stage LC filter inductor and inserting a current probe through a short wire soldered across pads of second stage LC filter.

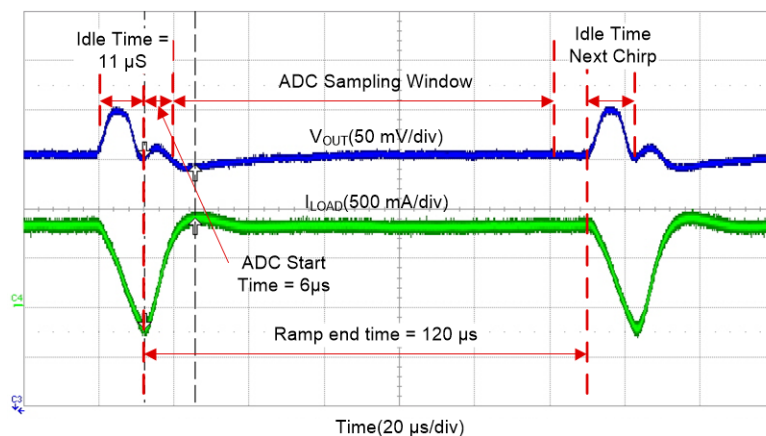

Figure 12. 1.0-V RF1 Supply Current During Chirping

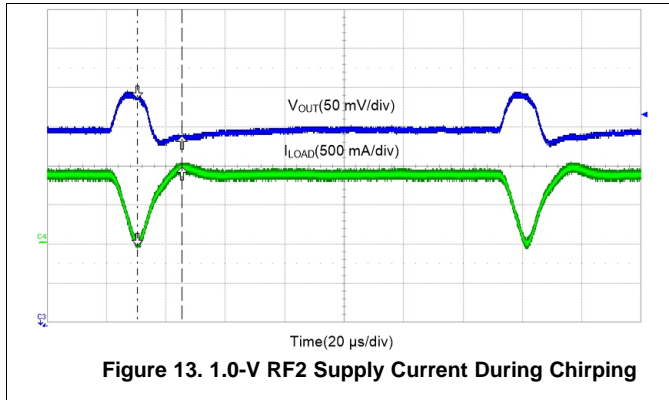

Figure 13. 1.0-V RF2 Supply Current During Chirping

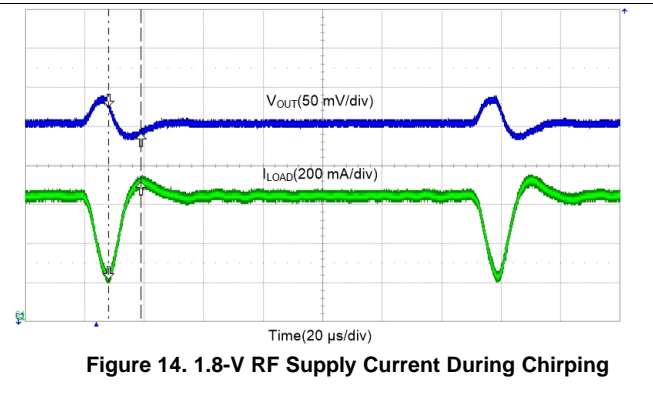

Figure 14. 1.8-V RF Supply Current During Chirping

4.2.1.2 1.0-V and 1.8-V RF Supply Voltage Transient Measurement During Chirping

Due to the fast rise in load current at the start of chirping, an undershoot on supply rail is observed. At the end of chirp, there is an overshoot seen on supply rail due to sudden drop in load current. There is no significant ringing observed on supply rails and supply voltages are within recommended voltage range during active chirping. Slightly higher overshoot seen on 1.0-V RF rail during chirp idle time is acceptable as during this time, there is no active data capture.

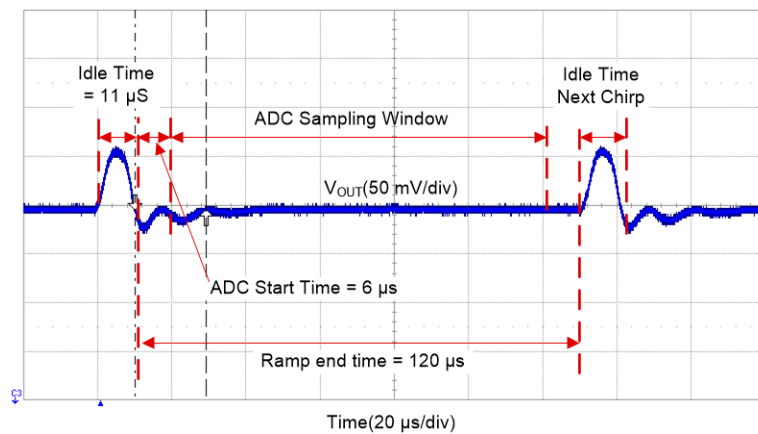

Figure 15. 1.0-V RF1 Supply Voltage Transient During Chirping

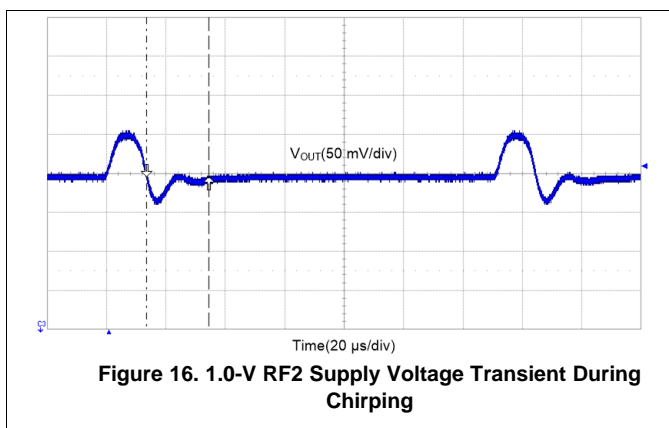

Figure 16. 1.0-V RF2 Supply Voltage Transient During Chirping

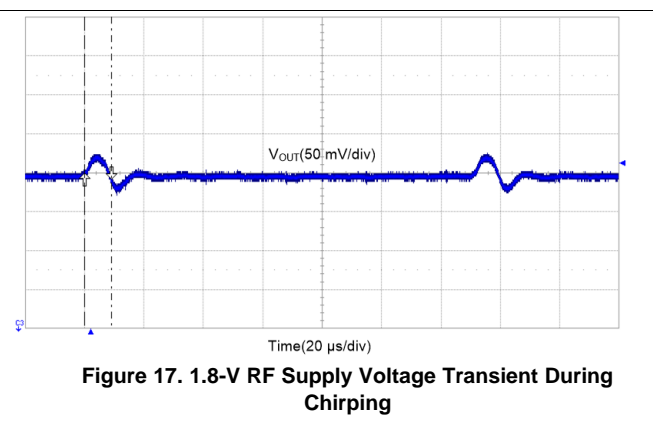
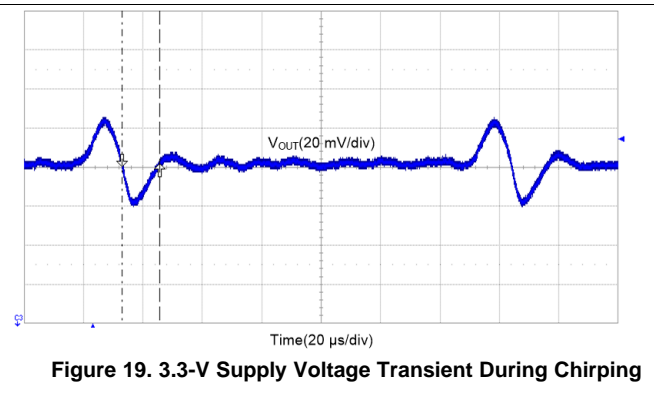
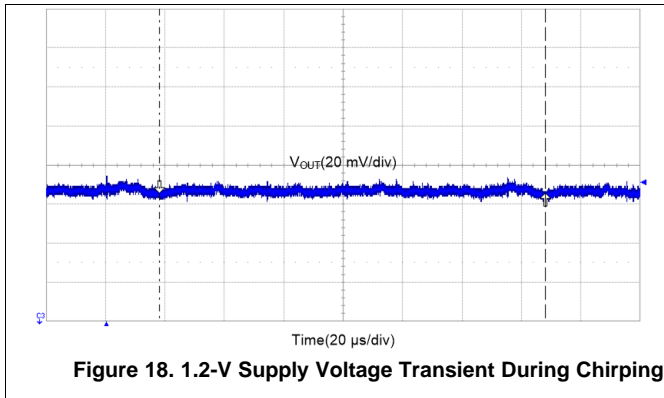

Figure 17. 1.8-V RF Supply Voltage Transient During Chirping

4.2.2 1.2-V and 3.3-V Supply Transient Measurement Results

On 1.2-V supply rail, load current is mostly stable during chirping and hence no considerable voltage transients (less than 15-mV pk-pk) observed during chirping. On 3.3-V supply rail, from AWR input side, load current is stable during chirping, but 3.3-V pre-regulator itself goes through the large load transient during chirping and hence around 50-mV pk-pk supply transient is observed, but it is well within AWR recommended operating supply range.



4.3 RF Measurement Results

Several Radar system level tests conducted to see whether switching regulator noise affects the radar data in real time using mmWave studio data acquisition system. No noticeable switching regulator related spurs observed on radar data. Several chirp profiles and device settings were tested and analyzed, but only limited plots are shown in this application report.

4.3.1 Metal Plate Testing in Chirp Mode

This test was conducted by placing the metal plate close to the antenna (at 10-cm) to have the maximum reflection to clearly see the PMIC related spurs on the FFT plots. Captured data is analyzed using 1-D FFT plots. A typical Chirp profile-1 with 0-Hz slope is used for this testing. Test is also repeated by shorting the second stage LC filter inductor to see the impact of LC filter.

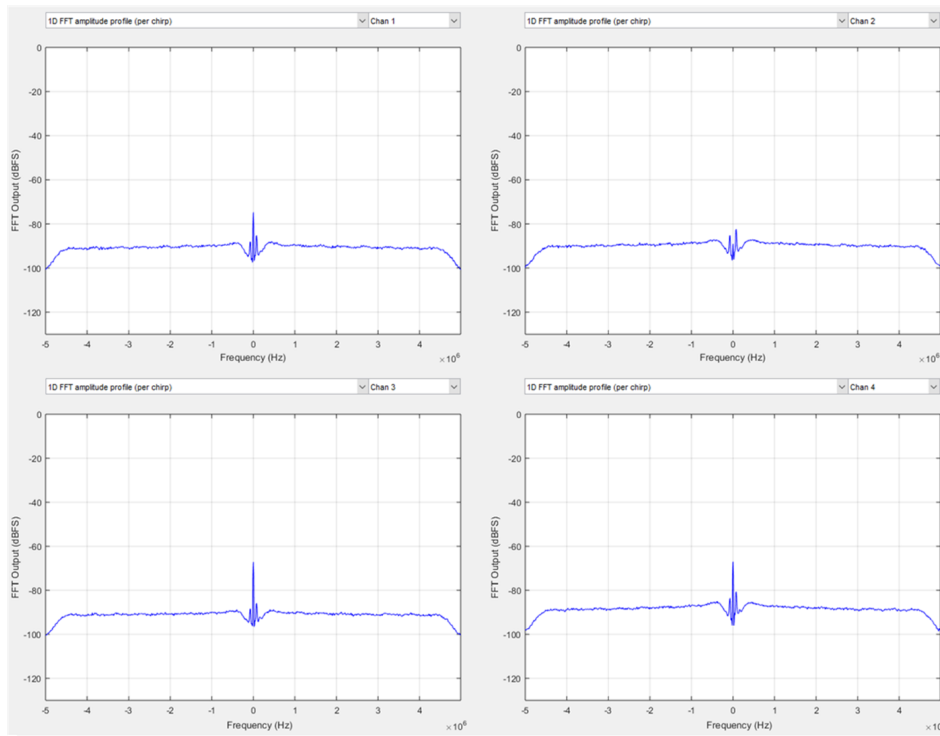

Figure 20. 1D-FFT Plot With Metal Plate Kept In Front of Antenna With 0-Hz Frequency Slope and With LC Filter

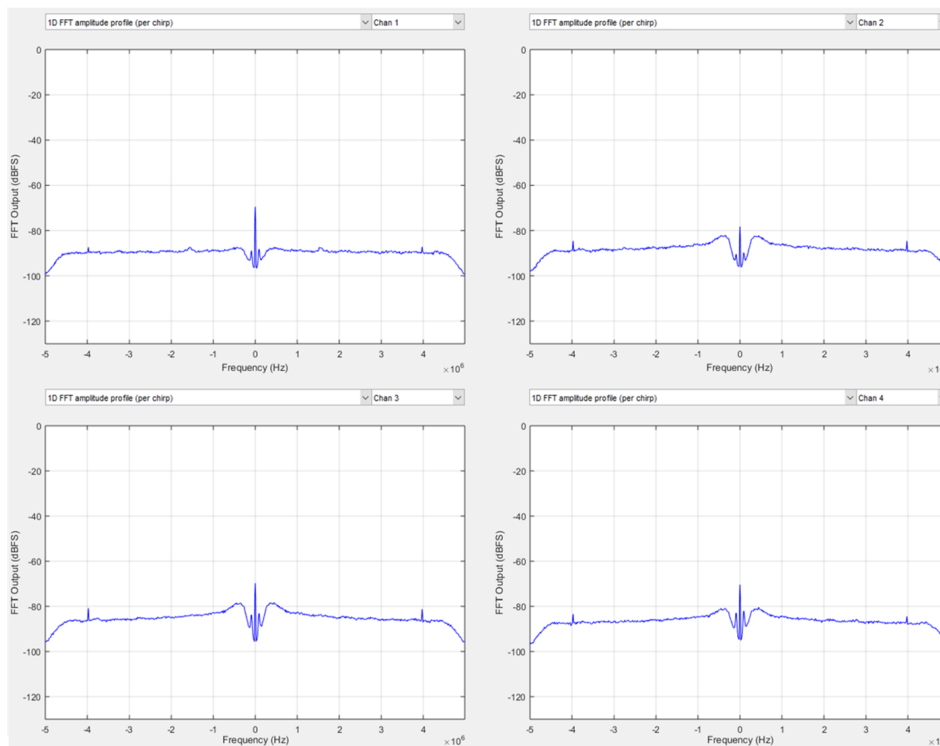

Figure 21. 1D-FFT Plot With Metal Plate Kept In Front of Antenna With 0-Hz Frequency Slope and Without LC Filter

4.3.2 Metal Plate Testing In Continuous Wave (CW) Mode

With 1-D FFT plots with limited data averaging, FFT noise floor is higher and very low amplitude noise information can be below the noise floor. To study the very low amplitude noise, AWR1843 is configured in CW mode with large sample size (500K). This test was conducted by placing the metal plate close to the antenna (at 10-cm) to have the maximum reflection to clearly see the PMIC related spurs on the FFT plots. Captured data is analyzed using FFT plots. Test is also repeated by shorting the second stage LC filter inductor to see the impact of LC filter.

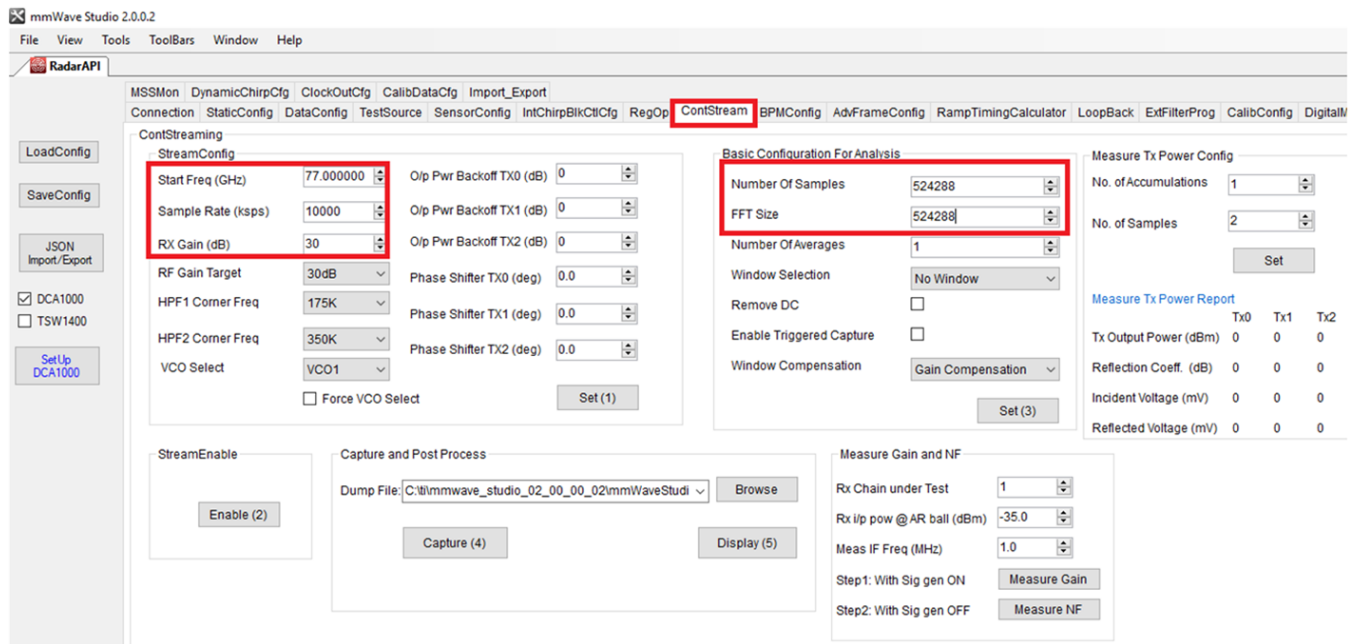

Figure 22. CW Capture Settings

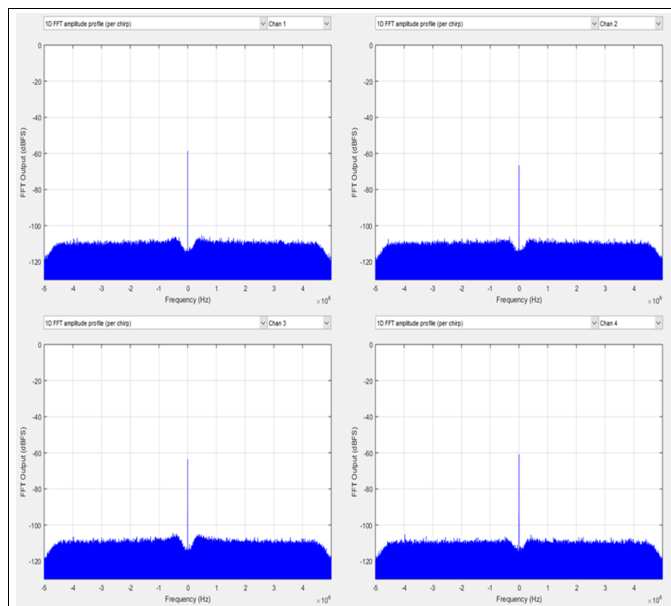

Figure 23. 1D-FFT Plot In CW Mode With Metal Plate Kept In Front of Antenna With 0-Hz Frequency Slope and With LC Filter

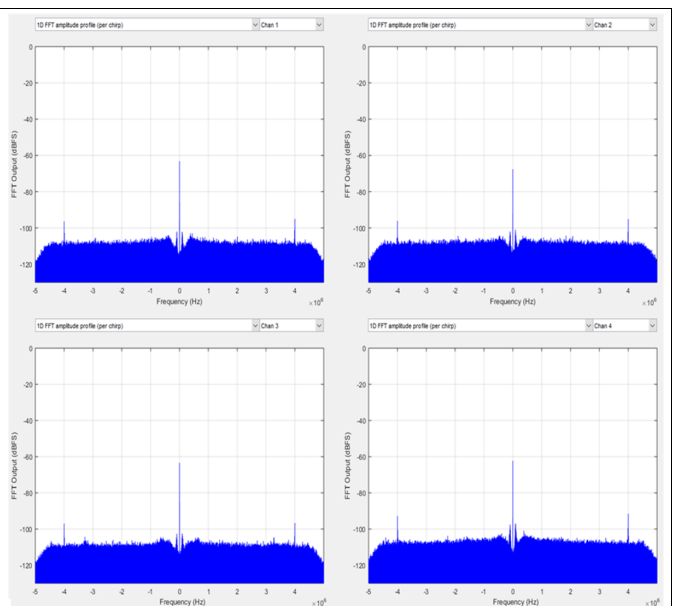

Figure 24. 1D-FFT Plot In CW Mode With Metal Plate Kept In Front of Antenna With 0-Hz Frequency Slope and Without LC Filter

4.3.3 Anechoic Chamber Tests

To avoid external interfaces affecting the captured radar data, radar system level testing was carried out inside an anechoic chamber.

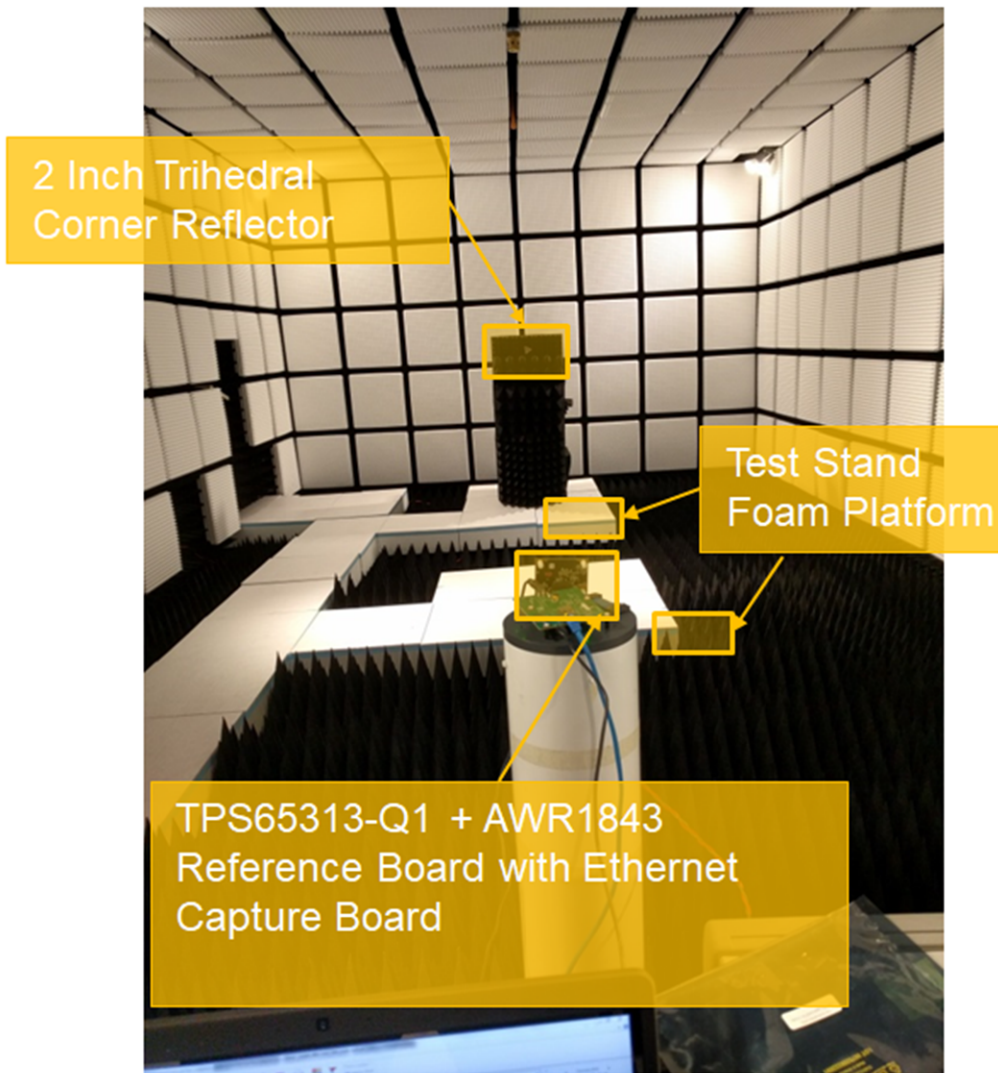

Figure 25. Anechoic Chamber Test Setup

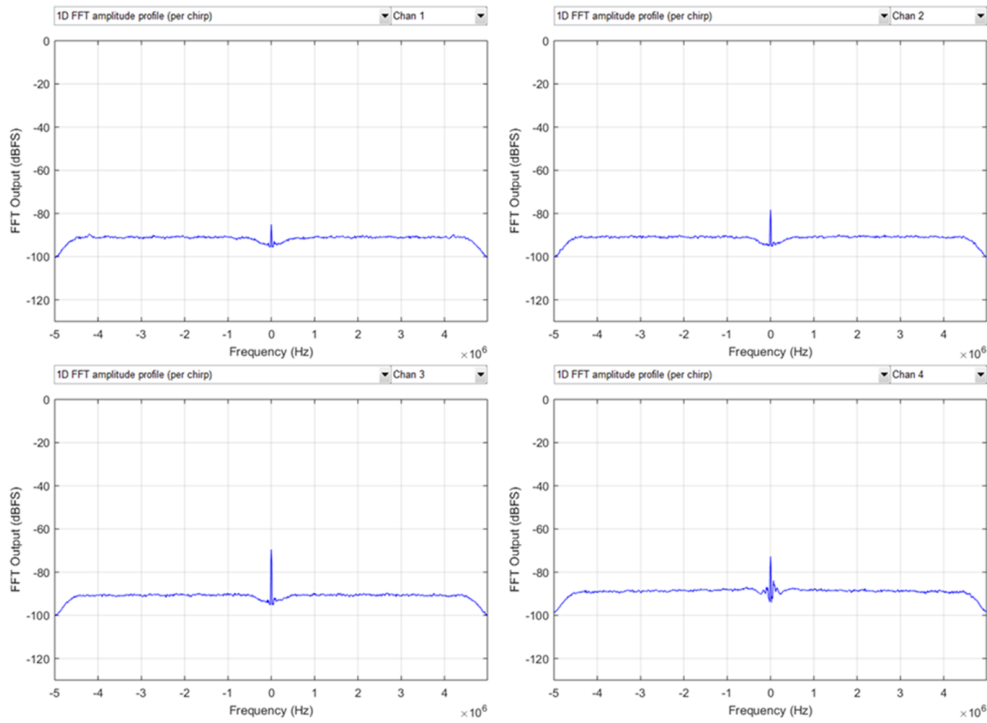

Figure 26. 1D-FFT Plot With 0-Hz Frequency Slope-idle Channel

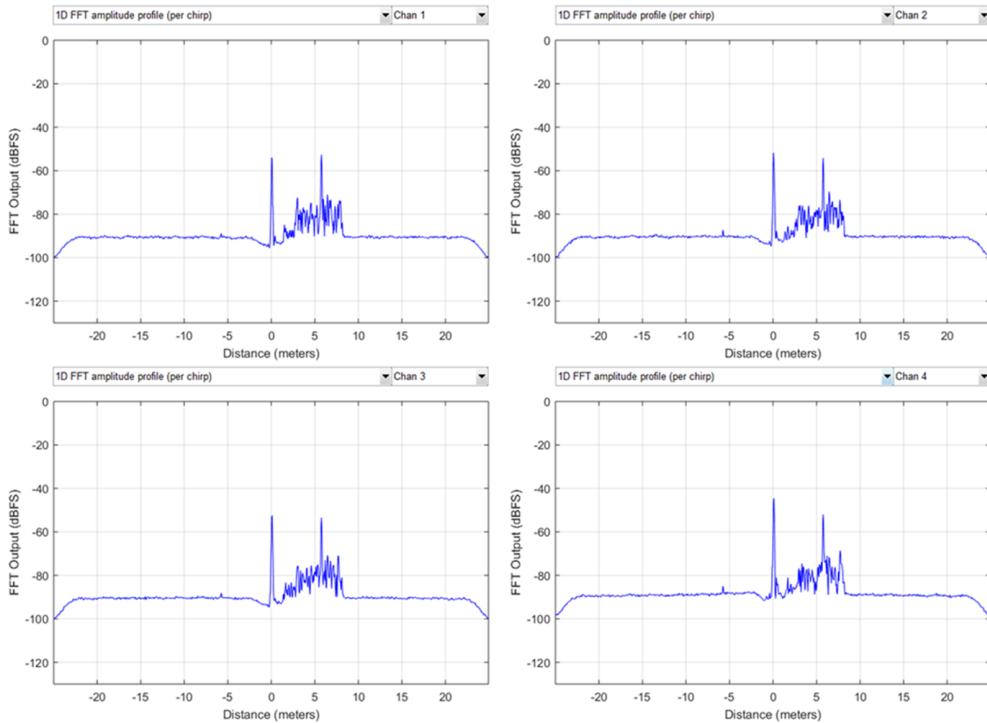

Figure 27. 1D-FFT Plot With 2 Inch Trihedral Corner Reflector Placed at 5 Meter Distance From Antenna

FFT tone observed at 5 Meter distance is due to the Corner Reflector Placed at 5 Meter Distance From Antenna

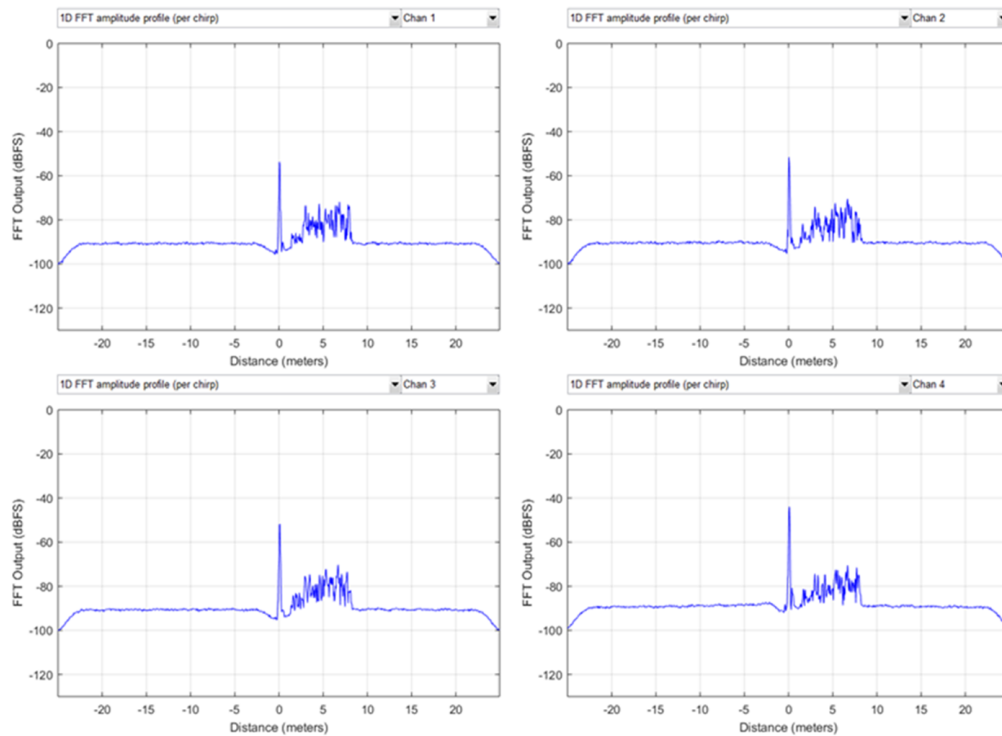

Figure 28. 1D-FFT Plot Without 2 Inch Trihedral Corner Reflector Placed at 5 Meter Distance From Antenna

Noise clutter seen around 5 Meter distance is due to the test stand foam platform and not related to any board related performance issues.

4.3.4 Chirp Linearity Tests

Chirp linearity tests are performed to determine the effects of the switching regulators noise on chirp linearity. No significant glitches are observed and results are good.

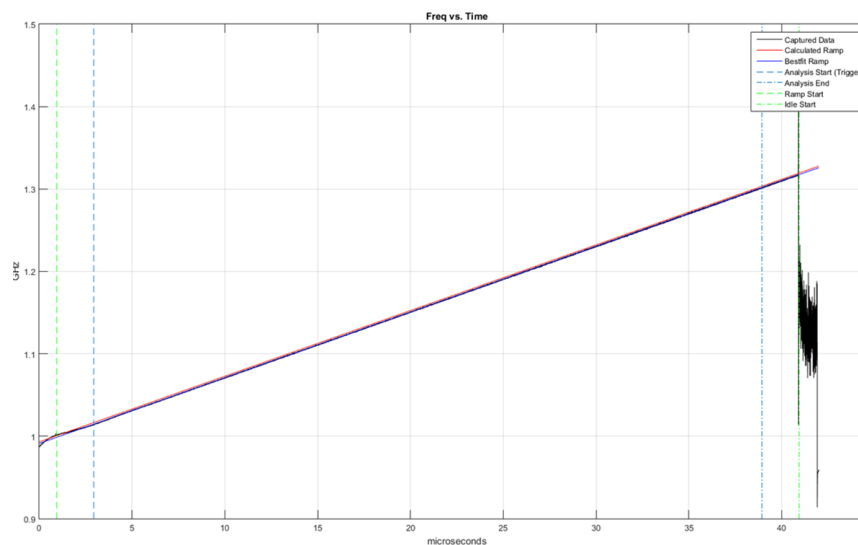

Figure 29. Frequency vs Time Linearity Plot for Chirp Profile-1

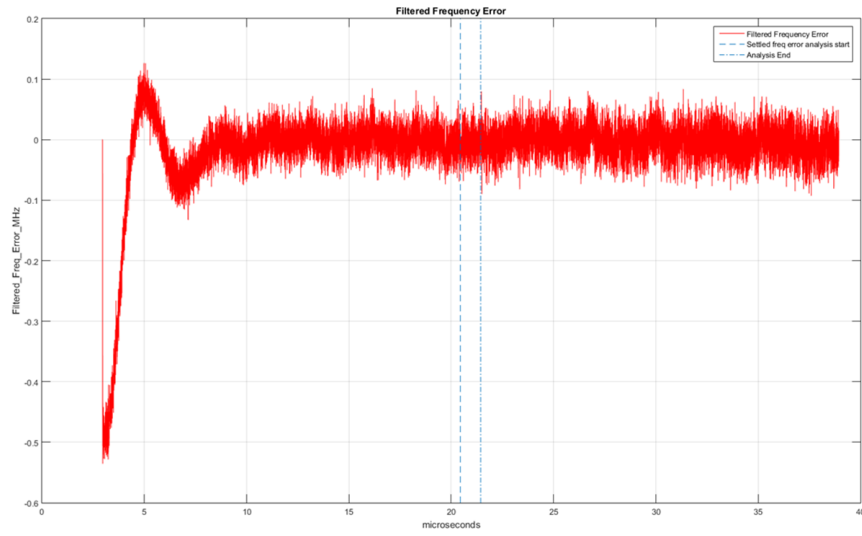

Figure 30. Filtered Frequency Error Plot for Chirp Profile-1

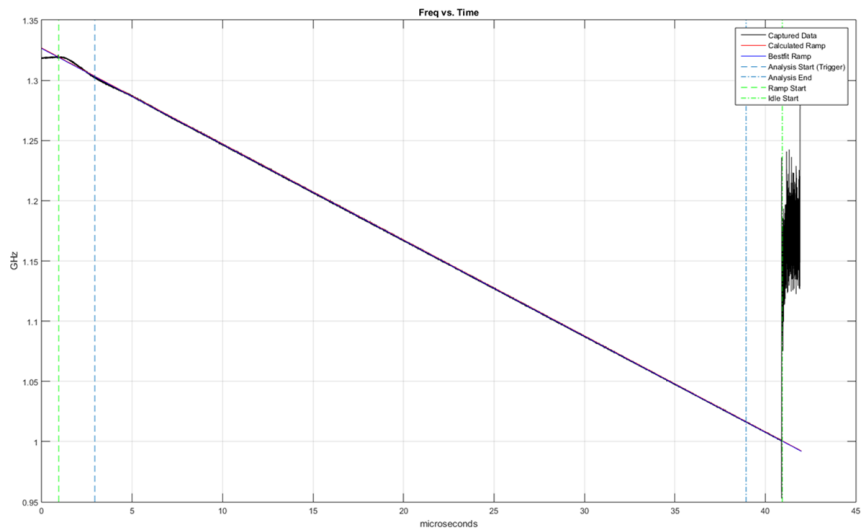

Figure 31. Frequency vs Time Linearity Plot for Chirp Profile-1 With Negative Frequency Slope

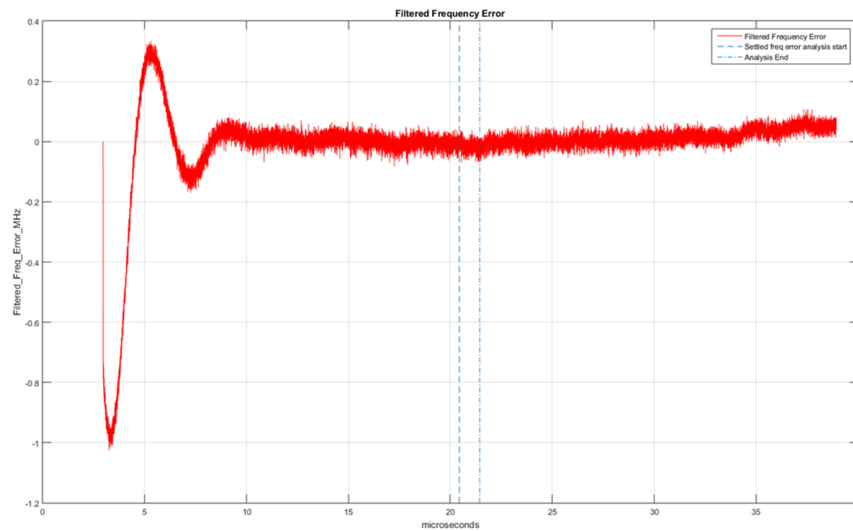

Figure 32. Filtered Frequency Error Plot for Chirp Profile-1 With Negative Frequency Slope

4.4 Power Supply Stability Test Results

4.4.1 Load Transient Measurements

Load transient tests were done by applying a very fast load transients (switched resistive load) on regulator outputs and output voltage is measured on the regulator output capacitor close to the regulators. These tests are intended to see the regulator stability performance for the large load transients. All the regulators show stable load transient performance.

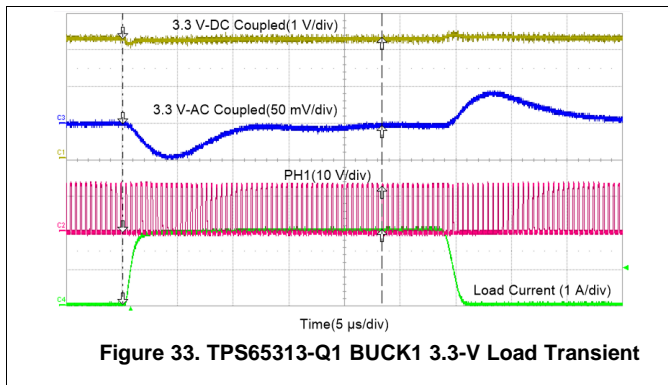

Figure 33. TPS65313-Q1 BUCK1 3.3-V Load Transient

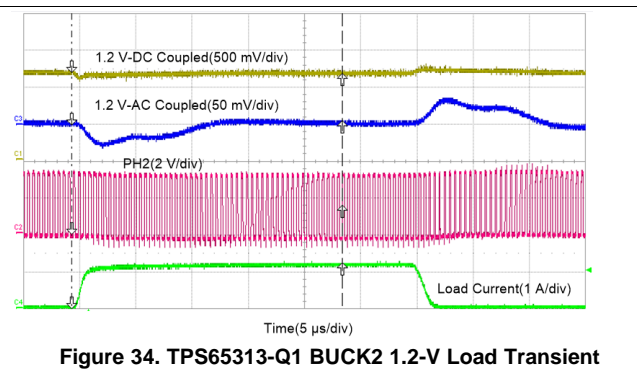
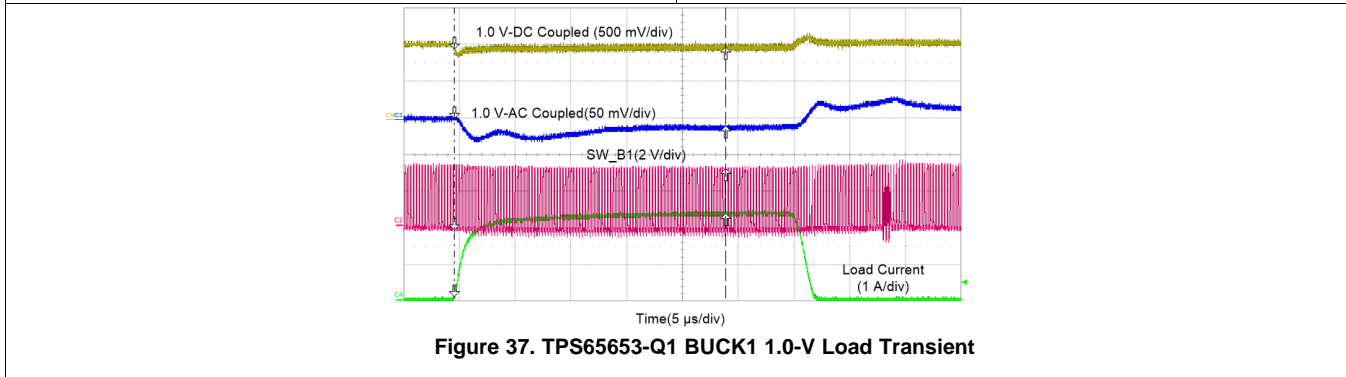
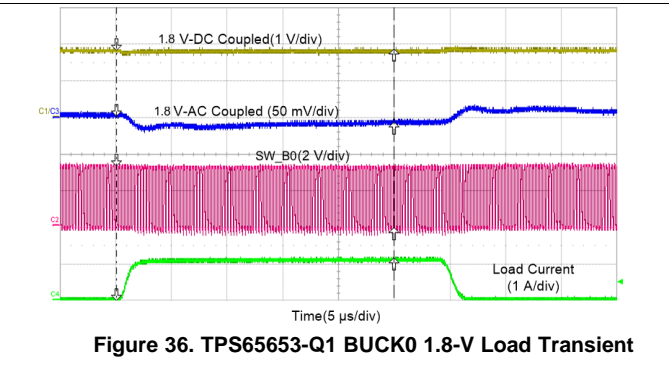
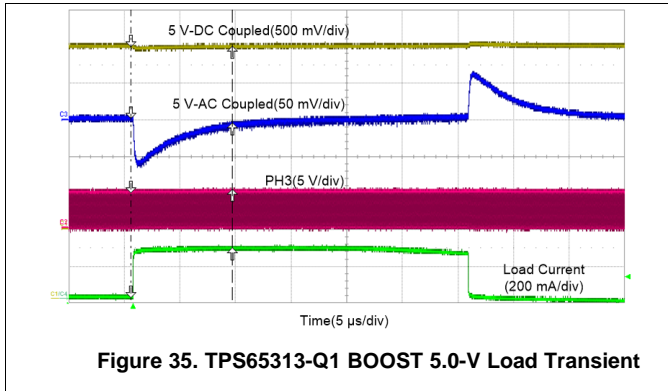
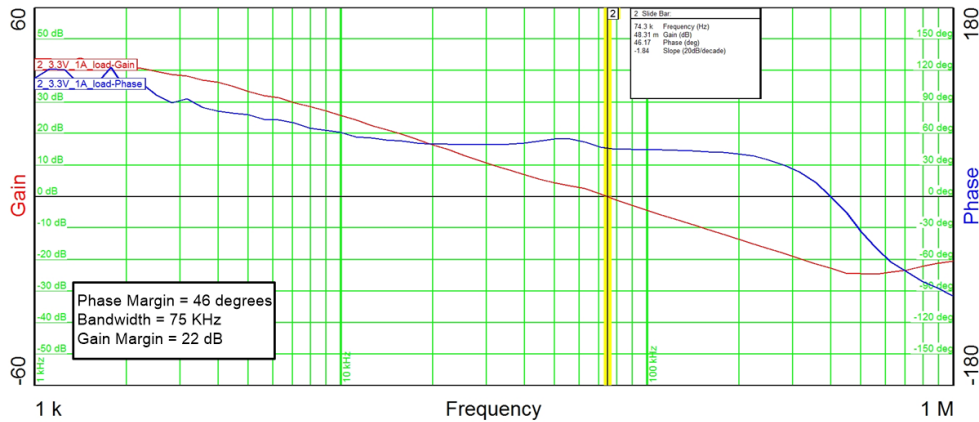

Figure 34. TPS65313-Q1 BUCK2 1.2-V Load Transient



4.4.2 Signal Bode Plot Measurements

Small signal bode plot measurements are done to verify the regulator stability performance by injecting a small signal through the feedback pin using bode plot analyzer. All the regulators show stable load transient performance.



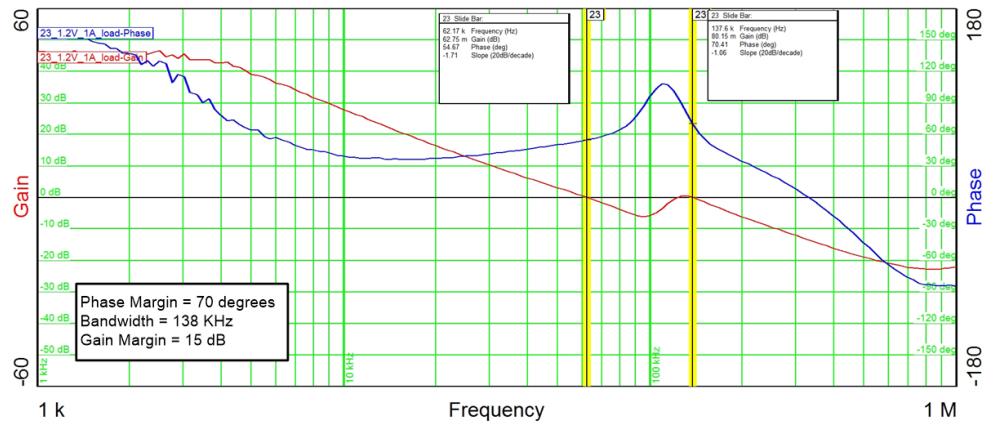

Figure 39. TPS65313-Q1 BUCK2 1.2-V Gain and Phase Plot

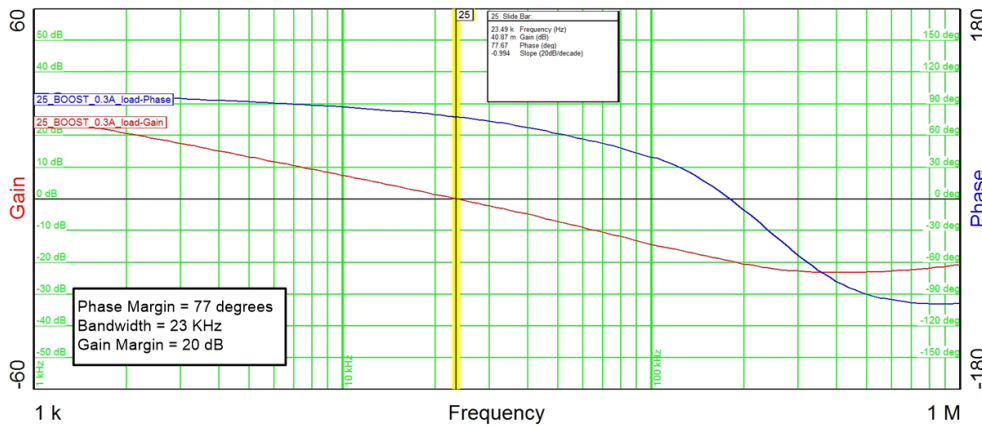

Figure 40. TPS65313-Q1 BOOST 5.0-V Gain and Phase Plot

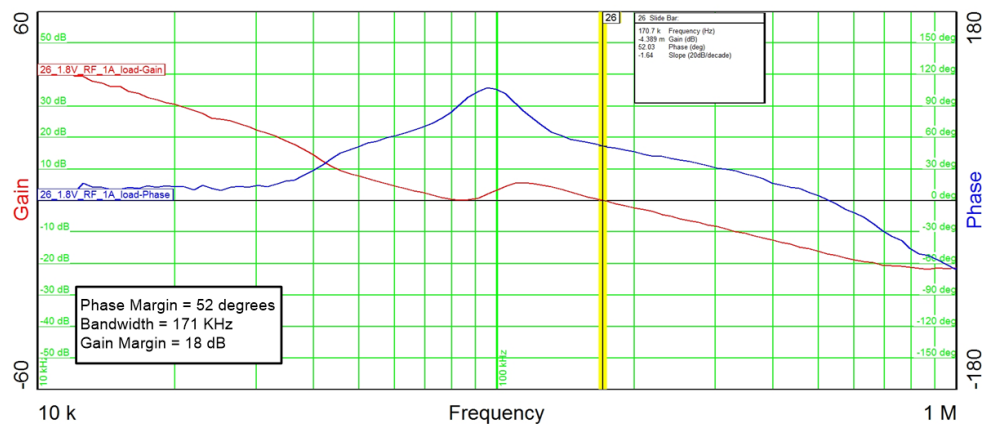

Figure 41. TPS65313-Q1 BUCK0 1.8-V Gain and Phase Plot

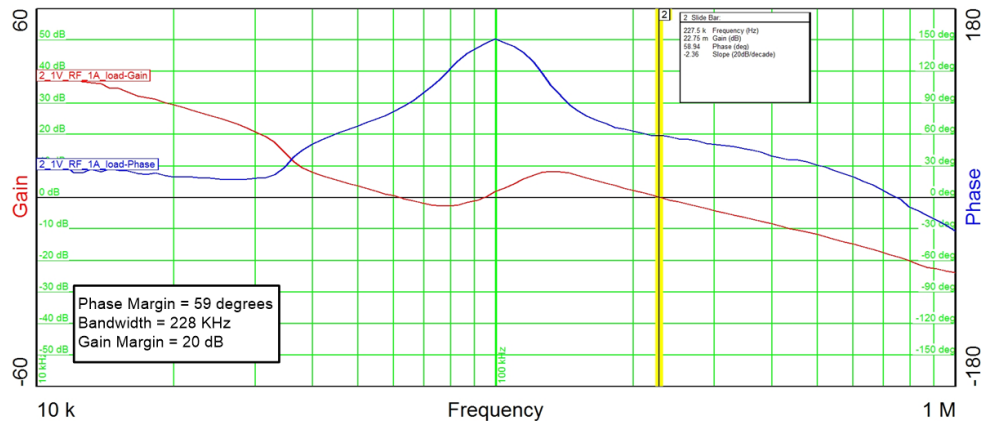

Figure 42. TPS65313-Q1 BUCK1 1.0-V Gain and Phase Plot

4.5 Thermal Measurement Results

4.5.1 Thermal Results With Radar Chirping

Thermo camera measurements are done on the board to estimate the PMIC junction temperature for different chirp settings at room temperature. Measurement is taken after 5 minutes of device operation to have a stable temperature reading.

Table 9. Thermal Measurements Summary

Temperature Measurement / Test Condition	AWR in Reset	AWR powered up, but no chirps	25% duty cycle chirp	50% duty cycle chirp	60% duty cycle chirp
TPS65313-Q1 topside	39	46	53	58	62
TPS65653-Q1 topside	32	38	44	50	52
Board temperature close to TPS65313-Q1	34	40	45	50	52
Board temperature close to TPS65653-Q1	32	38	44	49	52

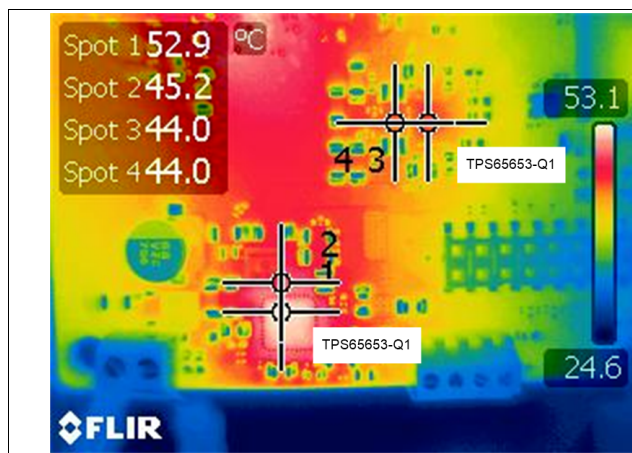

Figure 43. 25% Duty Chirping With 2-Tx On

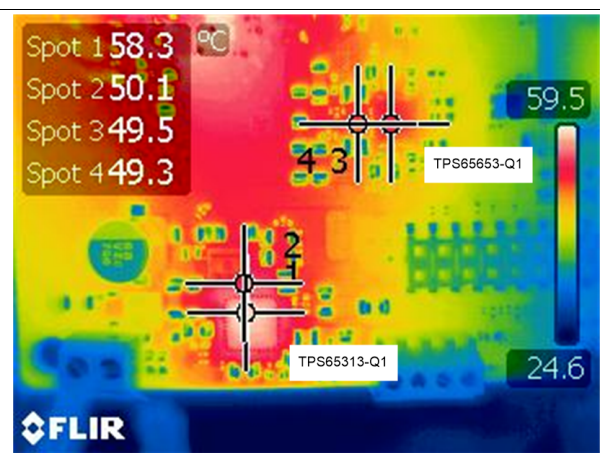

Figure 44. 50% Duty Chirping With 2-Tx On

4.5.2 Estimation of Worst Case PMIC Junction Temperature for AWR Max Current Requirements

For estimating the worst case PMIC junction temperature at PCB temperature = 125°C, fixed DC load currents close to AWR1843 worst case peak currents were applied on the regulators and board thermal resistance is calculated. Based on the calculated thermal resistance, worst case device junction temperature is estimated. But in reality, due to the chirp profile, actual device temperature raise is much lower than this estimation. Based on the thermal measurements, both ICs can operate under AWR worst case power requirements without need of the additional heat sink.

Table 10. Thermal Measurements for Both ICs

Parameter	TPS65313-Q1 ⁽¹⁾	TPS65653-Q1 ⁽²⁾
Device power dissipation ⁽³⁾	1.6 W	450-mW
PCB temperature ≈ 1-mm away from device (measured in room temperature)	54°C	50°C
Junction temperature (measured in room temperature)	74°C	57°C
Calculated Theta-JB based on thermal measurements at room temperature	12.5 °C/W	15.5 °C/W
Estimated junction temperature with PCB temperature at 125°C	145°C	132°C

⁽¹⁾ Load current used on TPS65313-Q1: BUCK1 = 2-A, BUCK2 = 1-A, BOOST = 0.3-A.

⁽²⁾ Load current used on TPS65653-Q1: BUCK0 = 1-A and BUCK1 = 2.3-A.

⁽³⁾ Power dissipation estimation is based on the regulator efficiency at the applied load current.

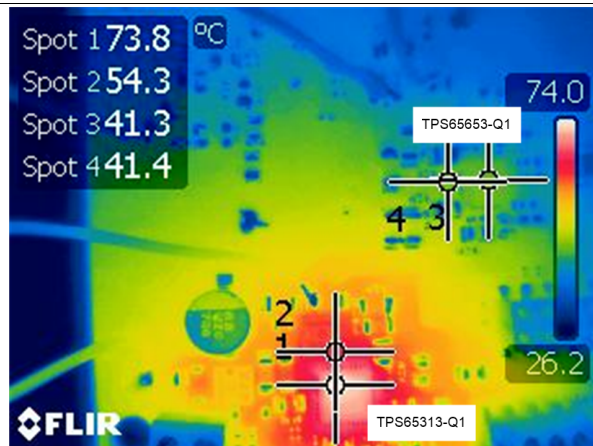

Figure 45. TPS65313-Q1 Device Thermal Result With Fixed DC Load

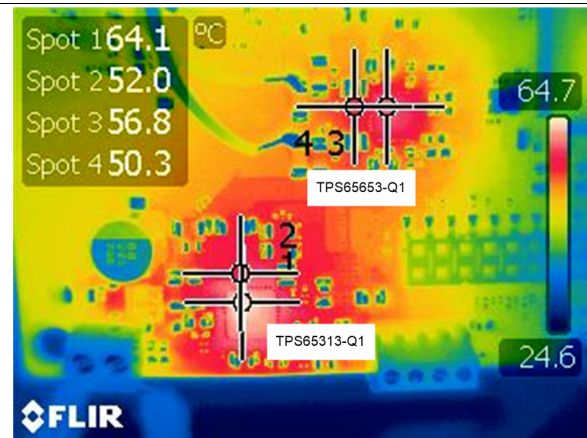

Figure 46. TPS65653-Q1 Device Thermal Result With Fixed DC Load

5 Schematics

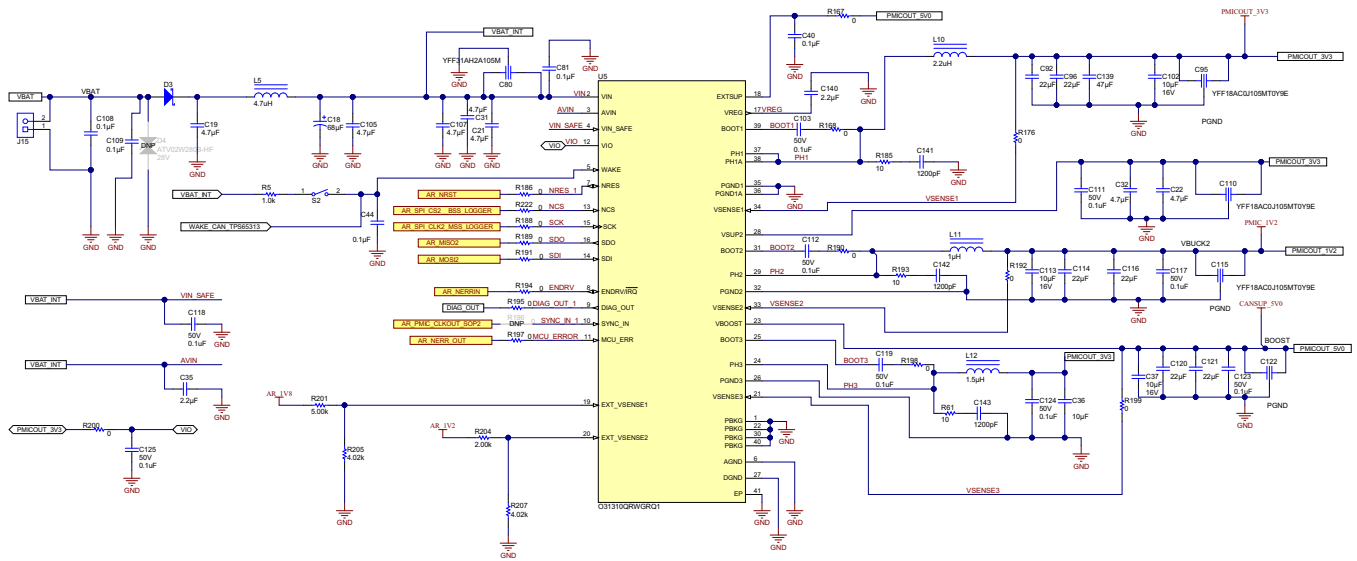

Figure 47. TPS65313-Q1 Schematics

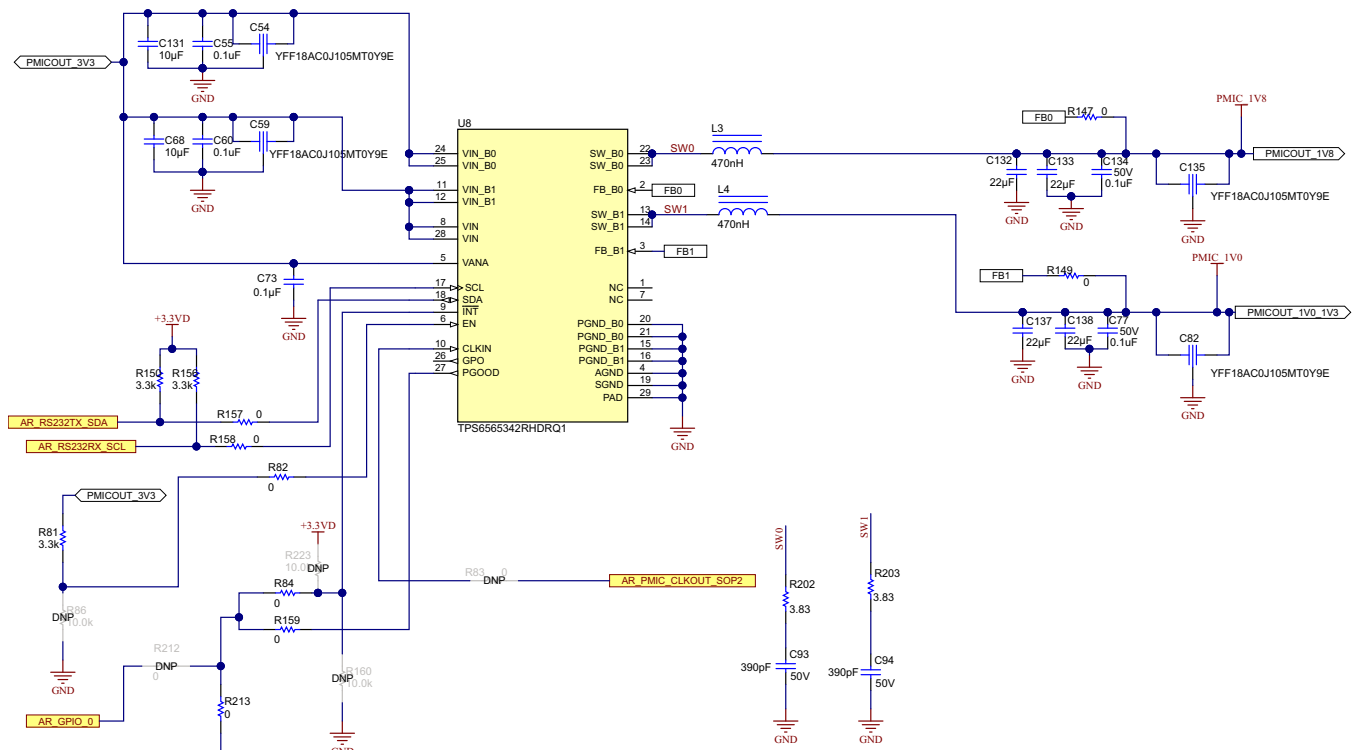

Figure 48. TPS65653-Q1 Schematics

AWR1843

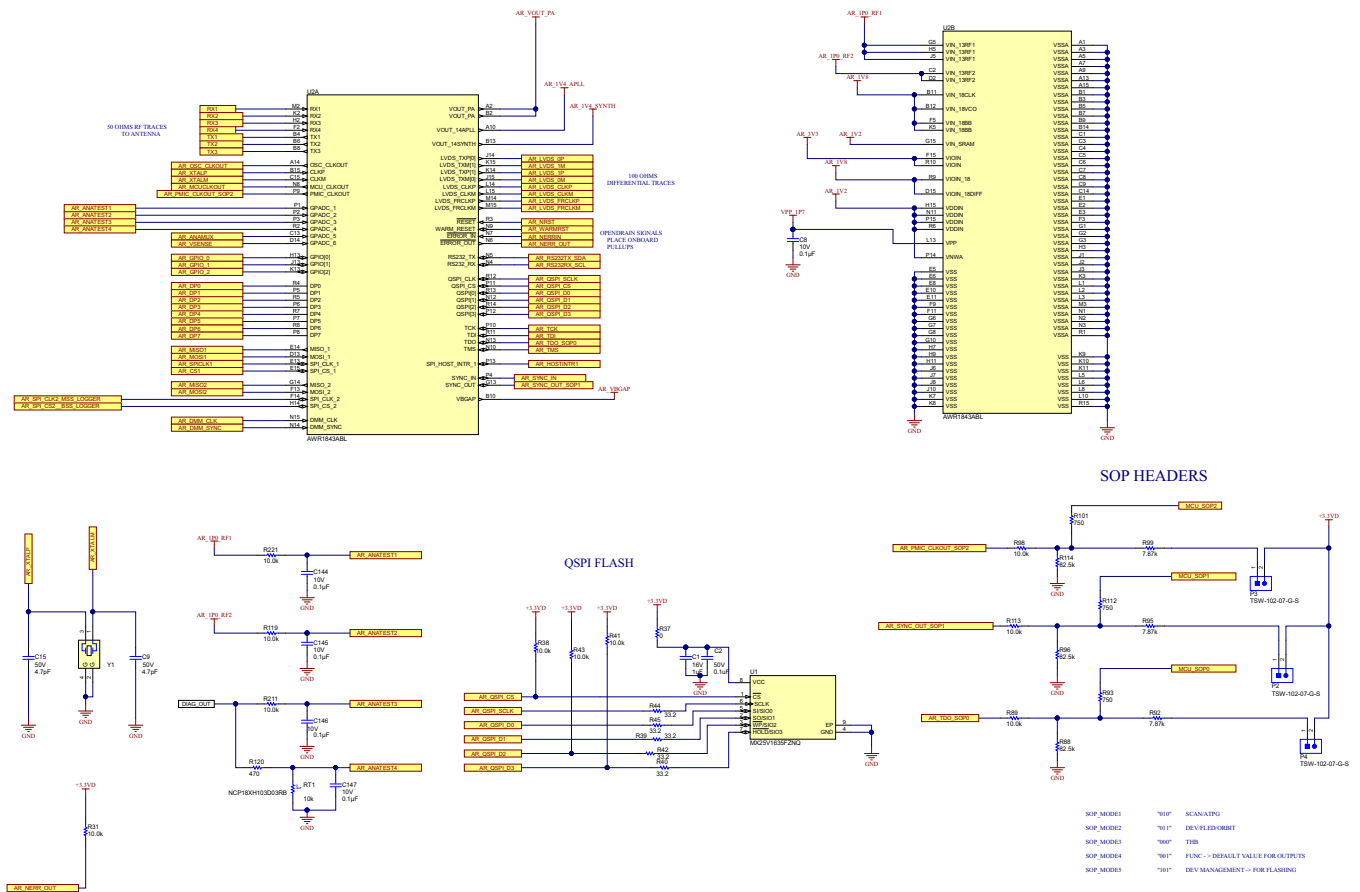
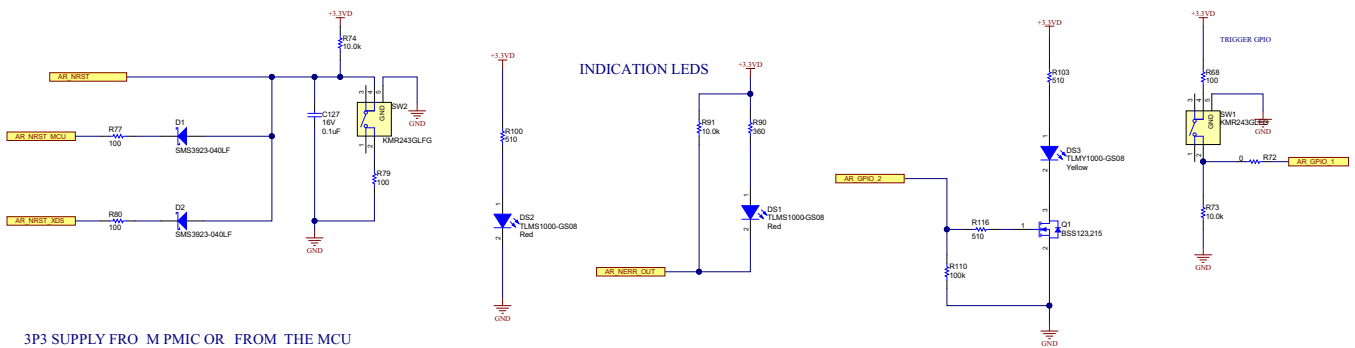

Figure 49. AWR1843 Schematics

RESET AND LEDS

Not needed for end equipment



3P3 SUPPLY FROM PMIC OR FROM THE MCU

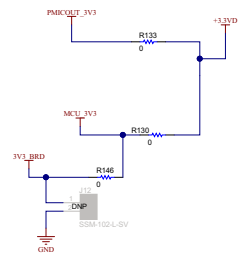

Figure 52. Power RST LEDs

These circuits are used only for data capture / debug purpose and not needed for end equipment

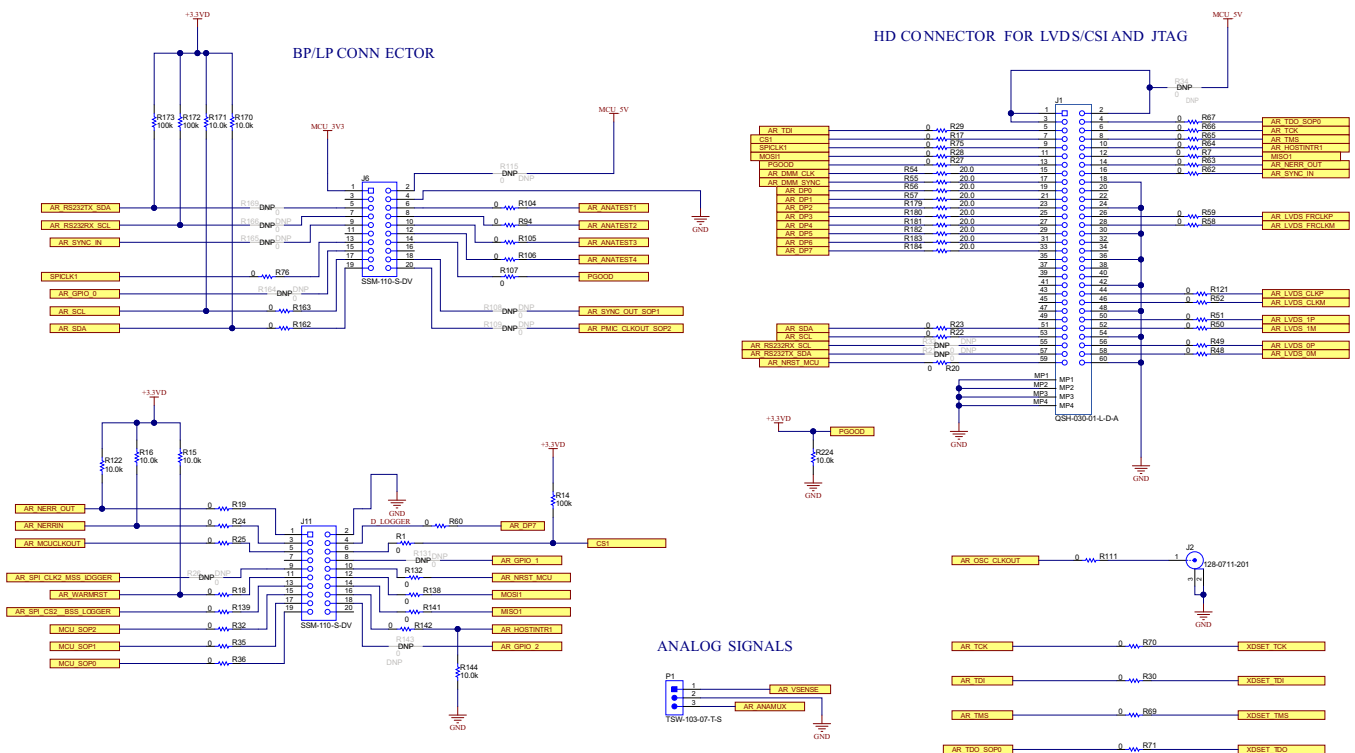

Figure 53. Connectors

6 PCB Layer

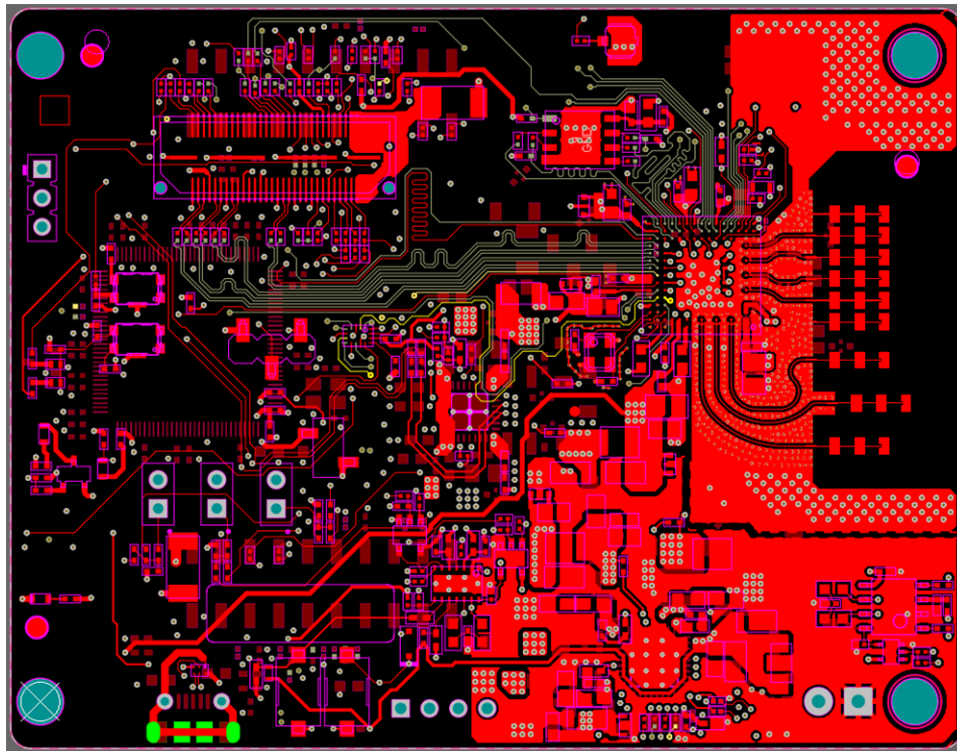

Figure 55. PCB Top Layer

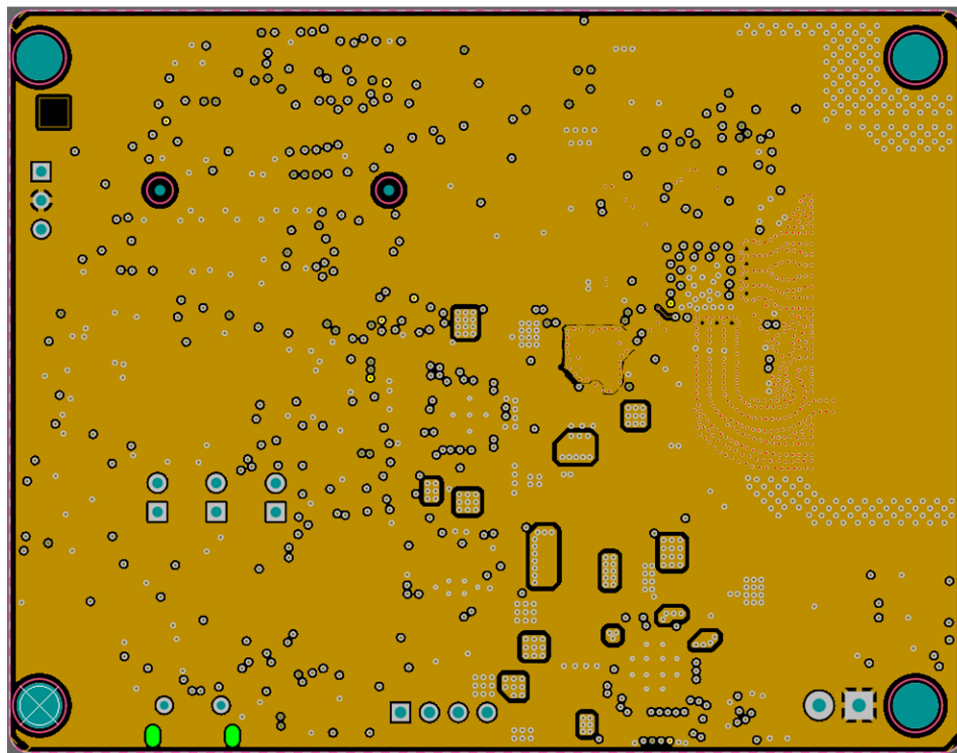

Figure 56. PCB Inner Layer-1

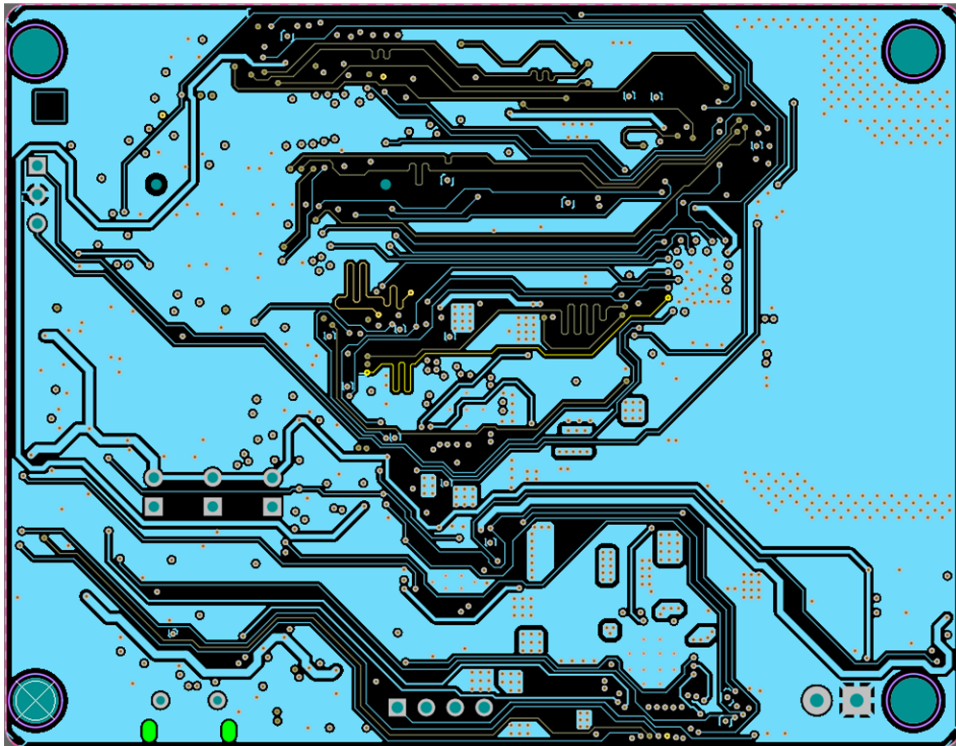

Figure 57. PCB Inner Layer-2

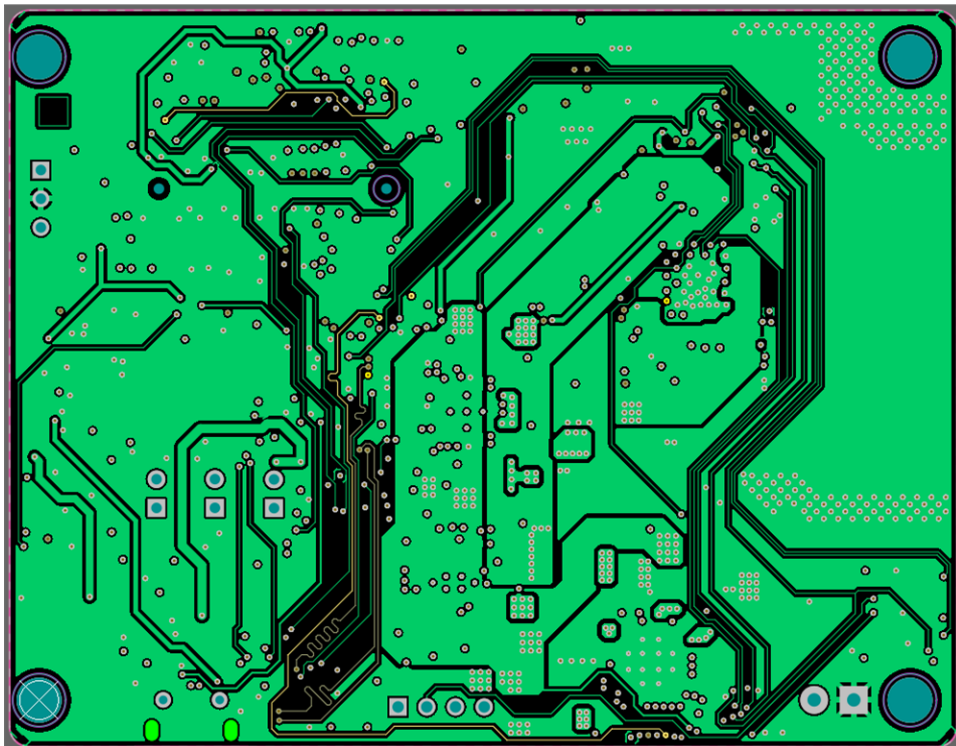

Figure 58. PCB Inner Layer-3

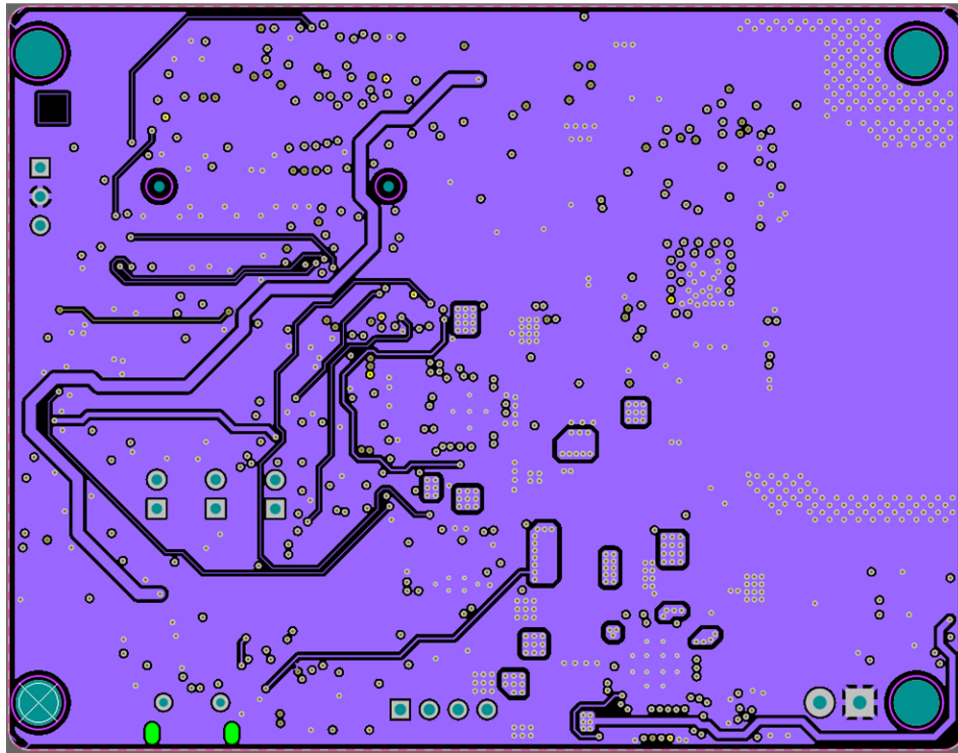

Figure 59. PCB Inner Layer-4

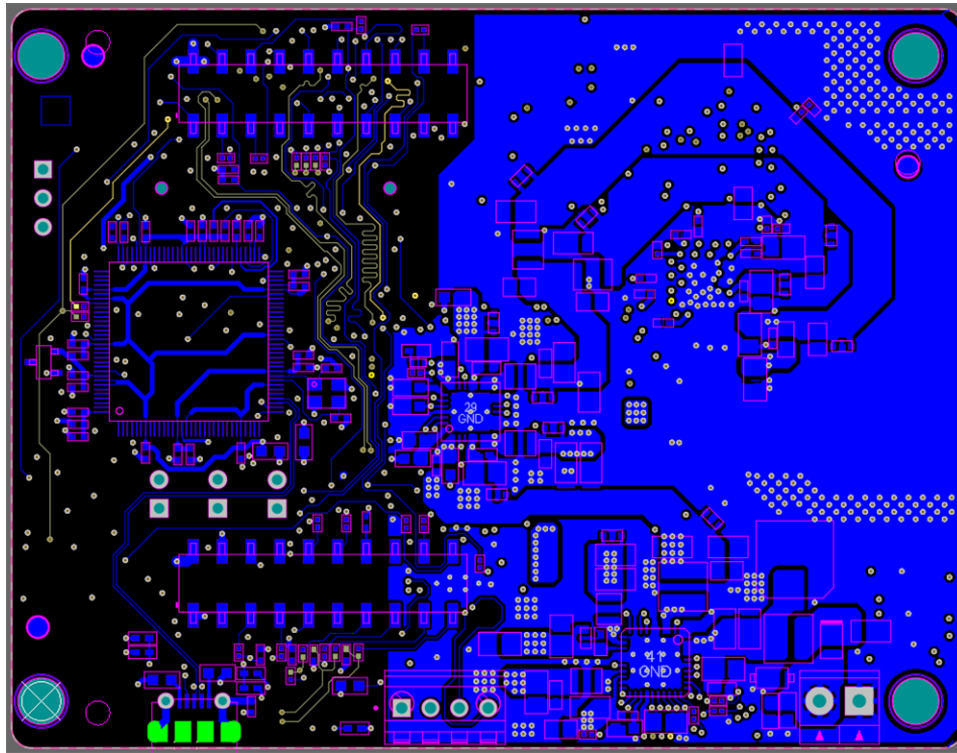

Figure 60. PCB Bottom Layer

7 Bill of Materials

Table 11. Radar Board Bill of Materials

Designator	Quantity	Value	Description	Package Reference	Part Number	Manufacturer	Alternate Part Number	Alternate Manufacturer
C1, C13, C14	3	1- μ F	CAP, CERM, 0603, X7R, 16-V, 1- μ F, \pm 10%	0603	CGA3E1X7R1C105K	TDK		
C2, C11, C23, C25, C27, C55, C60, C77, C103, C111, C112, C117, C118, C119, C123, C124, C125, C134	18	0.1- μ F	CAP, CERM, 0402, X7R, 50-V, 100-nF, \pm 10%	0402	CGA2B3X7R1H104K	TDK		
C3, C5, C7, C10, C12, C39, C47, C48, C51, C53, C56, C57, C84, C90	14	0.22- μ F	CAP, CERM, 0402, X7R, 16-V, 220-nF, \pm 10%	0402	CL05B224KO5NANC	Samsung Electro-Mechanics		
C4, C6, C16, C20, C43, C49, C64, C67, C71, C75, C76, C97, C127, C128	14	0.1- μ F	CAP, CERM, 0402, X7R, 16-V, 100-nF, \pm 10%	0402	CGA2B1X7R1C104K	TDK		

Table 11. Radar Board Bill of Materials (continued)

C8, C144, C145, C146, C147	5	0.1- μ F	CAP, CERM, 0.1- μ F, 10-V, \pm 10%, X7S, 0201	0201	C0603X7S1A 104K030BC	TDK		
C9, C15	2	4.7-pF	CAP, CERM, 4.7-pF, 50-V, \pm 2%, C0G/NP0, 0402	0402	GJM1555C1H 4R7BB01D	MuRata		
C17, C36, C45, C52, C58, C65, C68, C131	8	10- μ F	CAP, CERM, 0805, X7S, 10-V, 10- μ F, \pm 10%	0805	CGA4J3X7S1 A106K	TDK Corporation, TDK		
C18	1	68- μ F	CAP, Polymer Hybrid, 68 μ F, 35 V, \pm 20%, 35 Ω , 6.3 x 7.7 SMD	6.3x7.7	EEHZC1V680 XP	Panasonic		
C19, C21, C31, C105, C107	5	4.7- μ F	SMD/SMT SOFT 1206 50 V 4.7 μ F X7R 10% AEC-Q200	1206	CGA5L3X7R1 H475K	TDK		
C22, C32	2	4.7- μ F	CAP, CERM, 4.7- μ F, 10-V, \pm 20%, X7R, 0805	0805	C2012X7R1A 475M125AC	TDK		
C24, C26	2	4700-pF	CAP, CERM, 0402, X7R, 50-V, 4.7-nF, \pm 10%	0402	CGA2B2X7R 1H472K	TDK		
C28, C30, C92, C96, C114, C116, C120, C121, C132, C133, C137, C138, C153, C156	14	22- μ F	CAP, CERM, 1206, X7S, 10-V, 22- μ F, \pm 20%	1206	CGA5L1X7S1 A226M	TDK		
C29, C33, C38, C42, C50, C54, C59, C82, C95, C110, C115, C135, C157, C158, C159, C161	16	1- μ F	3-terminal filter, SMD	1.6 mm x 0.8 mm	YFF18AC0J1 05MT0Y9E	TDK		
C35	1	2.2- μ F	CAP, CERM, 0805, X7R, 50-V, 2.2- μ F, \pm 10%	0805	CGA4J3X7R1 H225K	TDK		
C37, C98, C99, C102, C113, C126, C148, C149, C150, C151, C152, C160, C162	13	10- μ F	CAP, CERM, 10- μ F, 16-V, \pm 10%, X7R, 0805	0805	CL21B106KO QNNNE	Samsung Electro-Mechanics		
C40, C44, C81, C108, C109	5	0.1- μ F	CAP, CERM, 0603, X8R, 50-V, 100-nF, \pm 10%	0603	CGA3E3X8R 1H104K	TDK		
C61, C62, C129	3	1- μ F	CAP, CERM, 1- μ F, 6.3-V, \pm 20%, X7S, 0402	0402	C1005X7S0J 105M050BC	TDK		

Table 11. Radar Board Bill of Materials (continued)

C63, C70	2	8-pF	CAP, CERM, 8-pF, 50-V, \pm 6%, C0G/NP0, 0402	0402	GRM1555C1 H8R0DA01D	MuRata		
C66, C69, C130	3	0.01- μ F	CAP, CERM, 0402, X7R, 25-V, 10-nF, \pm 10%	0402	CGA2B2X7R 1E103K	TDK		
C73	1	0.1- μ F	CAP, CERM, 0.1- μ F, 16-V, \pm 10%, X7R, 0603	0603	GRM188R71 C104KA01D	MuRata		
C74	1	2.2- μ F	CAP, CERM, 2.2- μ F, 10-V, \pm 10%, X7S, 0402	0402	C1005X7S1A 225K050BC	TDK		
C79, C100	2	22- μ F	CAP, CERM, 1206, X7R, 6.3-V, 22- μ F, \pm 20%	1206	CGA5L1X7R0 J226M	TDK		
C80	1	1- μ F	1- μ F, 3 Terminal Filtering Capacitor Type, SMD	3.2x1.6-mm	YFF31AH2A1 05M	TDK		
C87, C89	2	2.2- μ F	CAP, CERM, 0603, X7R, 6.3-V, 2.2- μ F, \pm 10%	0603	CGA3E1X7R 0J225K	TDK		
C93, C94	2	390-pF	CAP, CERM, 0402, C0G, 50-V, 390-pF, \pm 5%	0402	CGA2B2C0G 1H391J	TDK		
C101	1	0.01- μ F	CAP, CERM, 0.01- μ F, 25-V, \pm 10%, X7R, 0402	0402	GCM155R71 E103KA37D	MuRata		
C122	1	0.47- μ F	Feedthrough Capacitor, 0.47- μ F, 6.3-V, SMD	0603	YFF18PW0J4 74M	TDK		
C139	1	47- μ F	CAP, CERM, 47- μ F, 10-V, \pm 10%, X7R, 1210	1210	GRM32ER71 A476KE15L	MuRata		
C140	1	2.2- μ F	CAP, CERM, 2.2- μ F, 16-V, \pm 10%, X7R, 0805	0805	C2012X7R1C 225K125AB	TDK		
C141, C142, C143	3	1200-pF	CAP, CERM, 1200-pF, 50-V, \pm 10%, X7R, 0603	0603	GRM188R71 H122KA01D	MuRata		
D1, D2	2	V	Diode, Schottky, V, 0.01-A, SOD-882	SOD-882	SMS3923-040LF	Skyworks Solutions		
D3	1	60-V	Diode, Schottky, 60-V, 3-A, AEC-Q101, SOD-123HE	SOD-123HE	FSV360FP	Fairchild Semiconductor		

Table 11. Radar Board Bill of Materials (continued)

D5	1	40-V	Diode, Schottky, 40-V, 0.52-A, AEC-Q101, SOD-323	SOD-323	ZLLS400QTA	Diodes Inc.		
DS1, DS2	2	Red	LED, Red, SMD	1.6-mm x 0.8-mm	TLMS1000-GS08	Vishay-Semiconductor		
DS3	1	Yellow	LED, Yellow, SMD	1.6-mm x 0.8-mm	TLMY1000-GS08	Vishay-Semiconductor		
FID1, FID2, FID3, FID4, FID5, FID6	6		Fiducial mark. There is nothing to buy or mount.	N/A	N/A	N/A		
J1	1		Receptacle, 0.5-mm, 30 x 2, Gold, TH	Receptacle, 0.5-mm, 30x2, TH	QSH-030-01-L-D-A	Samtec		
J2	1		UMC Straight Jack Receptacle, 50-Ω, Gold, SMT	UMC Straight Jack Receptacle, SMT	128-0711-201	Cinch Connectivity		
J3	1		Terminal Block, 100-mil, 4 X 1 TH	10.62-mm x 10-mm x 6.5-mm	282834-4	TE Connectivity		
J6, J11	2		Receptacle, 2.54-mm, 10 x 2, Gold with Tin tail, SMT	Receptacle, 2.54-mm, 10x2, SMT	SSM-110-S-DV	Samtec		
J8	1		Connector, Receptacle, Micro-USB Type B, R/A, Bottom Mount SMT	Micro USB receptacle	105017-0001	Molex		
J14	1		Header, 2.54-mm, 3 x 1, Gold, SMT	Header, 2.54-mm, 3x1, SMT	M20-8770342	Harwin		
J15	1		Terminal Block, 3.5-mm Pitch, 2 x 1, TH	7.0-mm x 8.2-mm x 6.5-mm	ED555/2DS	On-Shore Technology		
L1	1	120-Ω	Ferrite Bead, 120-Ω @ 100-MHz, 1.9-A, 0603	0603	BLM18KG121 TH1D	MuRata		
L2, L7, L8, L9	4	100-nH	Inductor, Wirewound, Ferrite, 100-nH, 2.85-A, 0.024-Ω, AEC-Q200 Grade 1, SMD	3.2-mm x 2.2-mm x 2.5-mm	NLCV32T-R10M-EFRD	TDK		
L3, L4	2	470-nH	Inductor, Shielded, 470-nH, 4.7-A, 0.021-Ω, SMD	1008	DFE252012P D-R47M	MuRata Toko	DFE252012P-R47M	
L5	1	4.7-μH	Inductor, Shielded, Composite, 4.7-μH, 4.5-A, 0.0401-Ω, SMD	4.0-mm x 3.1-mm x 4.0-mm	XAL4030-472MEB	Coilcraft		

Table 11. Radar Board Bill of Materials (continued)

L10	1	2.2- μ H	Inductor, Shielded, Composite, 2.2- μ H, 6.1-A, 0.0201- Ω , AEC-Q200 Grade 1, SMD	4-mm x 4-mm	XEL4030-222MEB	Coilcraft		
L11	1	1- μ H	Inductor, Film, 1- μ H, 3.7-A, 0.042- Ω , AEC-Q200 Grade 0, SMD	2.5-mm x 2-mm	TFM252012A LMA1ROMTA A	TDK		
L12	1	1.5- μ H	Inductor, Film, 1.5- μ H, 3.1-A, 0.06- Ω , AEC-Q200 Grade 0, SMD	2.5-mm x 2-mm	TFM252012A LMA1R5MTA A	TDK		
P1	1		Header, 2.54-mm, 3x1, Tin, TH	Header, 2.54-mm, 3x1, TH	TSW-103-07-T-S	Samtec		
P2, P3, P4	3		Header, 100-mil, 2x1, Gold, TH	2x1 Header	TSW-102-07-G-S	Samtec		
Q1	1	100-V	MOSFET N-CH 100 V 150MA SOT-23	SOT-23	BSS123,215	Nexperia USA Inc.		None
R1, R3, R7, R17, R18, R19, R20, R22, R23, R24, R25, R27, R28, R29, R30, R32, R35, R36, R48, R49, R50, R51, R52, R58, R59, R60, R62, R63, R64, R65, R66, R67, R69, R70, R71, R72, R75, R76, R82, R84, R94, R104, R105, R106, R111, R117, R121, R132, R136, R138, R139, R141, R142, R159, R162, R163, R186, R187, R188, R189, R191, R194, R195, R197, R199, R209, R210, R213, R215, R216, R220, R222	72	0	RES, 0, 5%, 0.05 W, 0201	0201	CRCW02010 000Z0ED	Vishay-Dale		
R2, R81, R150, R156	4	3.3 k	RES, 3.3 k, 5%, 0.063 W, 0402	0402	CRCW04023 K30JNED	Vishay-Dale		

Table 11. Radar Board Bill of Materials (continued)

R4, R6, R8, R11, R12, R37, R78, R107, R128, R129, R152	11	0	RES, 0, 5%, 0.063 W, 0402	0402	ERJ-2GE0R00X	Panasonic		
R5	1	1.0 k	RES, 1.0 k, 5%, 0.063 W, AEC-Q200 Grade 0, 0402	0402	CRCW04021 K00JNED	Vishay-Dale		
R9, R10, R85, R87	4	61.9	RES, 61.9, 1%, 0.1 W, AEC-Q200 Grade 0, 0603	0603	CRCW06036 1R9FKEA	Vishay-Dale		
R13	1	33.2 k	RES, 33.2 k, 1%, 0.063 W, AEC-Q200 Grade 0, 0402	0402	CRCW04023 3K2FKED	Vishay-Dale		
R14, R110, R172, R173	4	100 k	RES, 100 k, 1%, 0.063 W, 0402	0402	CRCW04021 00KFKED	Vishay-Dale		
R15, R16, R38, R41, R43, R73, R74, R89, R91, R98, R113, R122, R144, R155, R170, R171, R206, R208	18	10.0 k	RES, 10.0 k, 1%, 0.063 W, 0402	0402	CRCW04021 0K0FKED	Vishay-Dale		
R31	1	10.0 k	RES, 10.0 k, 1%, 0.063 W, AEC-Q200 Grade 0, 0402	0402	CRCW04021 0K0FKED	Vishay-Dale		
R39, R40, R42, R44, R45	5	33.2	RES, 33.2, 1%, 0.05 W, 0201	0201	CRCW02013 3R2FNED	Vishay-Dale		
R46, R53, R119, R211, R218, R219, R221, R224	8	10.0 k	RES, 10.0 k, 1%, 0.05 W, 0201	0201	CRCW02011 0K0FKED	Vishay-Dale		
R54, R55, R56, R57, R179, R180, R181, R182, R183, R184	10	20.0	RES, 20.0, 1%, 0.05 W, 0201	0201	CRCW02012 0R0FNED	Vishay-Dale		
R61, R185, R193	3	10	RES, 10, 5%, 0.25 W, 0603	0603	CRCW06031 0R0JNEAHP	Vishay-Dale		
R68, R77, R79, R80, R154	5	100	RES, 100, 5%, 0.1 W, AEC-Q200 Grade 0, 0402	0402	ERJ-2GEJ101X	Panasonic		
R88, R96, R114	3	82.5 k	RES, 82.5 k, 1%, 0.063 W, AEC-Q200 Grade 0, 0402	0402	CRCW04028 2K5FKED	Vishay-Dale		
R90	1	360	RES, 360, 5%, 0.1 W, AEC-Q200 Grade 0, 0402	0402	ERJ-2GEJ361X	Panasonic		
R92, R95, R99	3	7.87 k	RES, 7.87 k, 1%, 0.063 W, AEC-Q200 Grade 0, 0402	0402	CRCW04027 K87FKED	Vishay-Dale		

Table 11. Radar Board Bill of Materials (continued)

R93, R101, R112	3	750	RES, 750, 1%, 0.063 W, AEC-Q200 Grade 0, 0402	0402	CRCW0402750RFKED	Vishay-Dale		
R100, R103, R116	3	510	RES, 510, 5%, 0.1 W, AEC-Q200 Grade 0, 0402	0402	ERJ-2GEJ511X	Panasonic		
R120	1	470	RES, 470, 0.5%, 0.05 W, 0201	0201	RC0201DR-07470RL	Yageo America		
R123, R124, R126, R127, R140	5	1.00 k	RES, 1.00 k, 1%, 0.063 W, 0402	0402	CRCW04021K00FKED	Vishay-Dale		
R125	1	4.87 k	RES, 4.87 k, 1%, 0.063 W, 0402	0402	CRCW04024K87FKED	Vishay-Dale		
R130, R133, R146, R161, R175	5	0	RES, 0, 5%, 0.125 W, 0603	0603	MCT06030Z000ZP500	Vishay/Beys chlag		
R134	1	49.9	RES, 49.9, 1%, 0.063 W, 0402	0402	CRCW040249R9FKED	Vishay-Dale		
R147, R149, R157, R158, R167, R168, R176, R190, R192, R198, R200	11	0	RES, 0, 5%, 0.063 W, 0402	0402	CRCW0402000Z0ED	Vishay-Dale		
R151, R153	2	330 k	RES, 330 k, 1%, 0.063 W, AEC-Q200 Grade 0, 0402	0402	CRCW0402330KFKED	Vishay-Dale		
R174	1	30.0 k	RES, 30.0 k, 1%, 0.063 W, AEC-Q200 Grade 0, 0402	0402	CRCW040230K0FKED	Vishay-Dale		
R201	1	5.00 k	RES, 5.00 k, 0.1%, 0.05 W, 0402	0402	PNM0402E5001BST1	Vishay-Dale		
R202, R203	2	3.83	RES, 3.83, 1%, 0.063 W, 0402	0402	CRCW04023R83FKED	Vishay-Dale		
R204	1	2.00 k	RES, 2.00 k, 0.1%, 0.063 W, 0402	0402	RG1005P-202-B-T5	Susumu Co Ltd		
R205, R207	2	4.02 k	RES, 4.02 k, 0.1%, 0.063 W, 0402	0402	ERA-2AEB4021X	Panasonic		
RT1	1	10 k	Thermistor NTC, 10.0 k \bullet , 0.5%, 0603	0603	NCP18XH103D03RB	MuRata		
S1, S2	2		Switch, Tactile, SPST, 12-V, SMD	SMD, 6 mm x 3.9 mm	434121025816	Würth Elektronik		
SW1, SW2	2		Switch, SPST-NO, Off-Mom, 0.01 A, 32 VDC, SMD	4.2 mm x 2.8 mm	KMR243GLFG	C&K Components		
U1	1		2.3-V – 3.6-V, 16M-BIT [x 1/x 2/x 4] CMOS FLASH Memory, WSON-8	WSON-8	MX25V1635FZNQ	Macronix International Co., LTD		

Table 11. Radar Board Bill of Materials (continued)

U2	1		AWR1843ABL, ABL0161B (FCBGA-161)	ABL0161B	AWR1843ABL	Texas Instruments		Texas Instruments
U3	1		Automotive Fault Protected CAN Transceiver With Flexible Data-Rate, D0008A (SOIC-8)	D0008A	TCAN1042H GVDQ1	Texas Instruments	TCAN1042H GVDRQ1	Texas Instruments
U4	1		Fault Protected CAN Transceiver with CAN FD, DMT0014A (VSON-14)	DMT0014A	TCAN1043H GDMTRQ1	Texas Instruments	TCAN1043H GDMTQ1	Texas Instruments
U5	1		High Voltage Power Management IC for Automotive Application, RWG0040B (VQFN-40)	RWG0040B	O31310QRW GRQ1	Texas Instruments		Texas Instruments
U6	1		Tiva C Series Microcontroller, 1024-KB Flash, 256-KB SRAM, 12 Bit, 20 Channels, -40 to 105 °C, 128-Pin TQFP (PDT), Green (RoHS & no Sb/Br), Tray	PDT0128A	TM4C1294NC PDTT3	Texas Instruments		
U7	1		Precision Micropower Shunt Voltage Reference, 0.5% accuracy, 2.5-V, 15 ppm / °C, 15 mA, -40 to 125 °C, 3-pin SOT-23 (DBZ), Green (RoHS & no Sb/Br)	DBZ0003A	LM4040C25Q DBZR	Texas Instruments		
U8	1		Dual Buck Converters for radar applications, RHD0028W (VQFN-28)	RHD0028W	TPS6565342 RHDRQ1	Texas Instruments		Texas Instruments
U9	1		Automotive Catalog Single Inverter, DCK0005A, LARGE T&R	DCK0005A	SN74LVC1G0 4QDCKRQ1	Texas Instruments		

Table 11. Radar Board Bill of Materials (continued)

U10	1		ESD-Protection Array for High-Speed Data Interfaces, 4 Channels, -40 to +85 °C, 6-pin SON (DRY), Green (RoHS & no Sb/Br)	DRY0006A	TPD4E004DR YR	Texas Instruments		
U11, U12	2		Automotive Catalog Single Bus Buffer Gate With 3-State Outputs, DBV0005A (SOT-23-5)	DBV0005A	1P1G126QDB VRQ1	Texas Instruments		
U14	1		10-Ω Quad SPDT Analog Switch, RSV0016A (UQFN-16)	RSV0016A	TS3A5018RS VR	Texas Instruments		Texas Instruments
Works With TI LaunchPad Logo	1		Works With TI LaunchPad Logo					
Y1	1		Crystal, 40-MHz, 8-pF, SMD	3.2x2.5mm	CX3225SA40 000D0PTWC C	Kyocera		
Y2	1		Crystal, 16-MHz, 15-ppm, 8-pF, AEC-Q200 Grade 1, SMD	3.2x0.55x2.5 mm	NX3225SA-16.000M-STD-CRS-2	NDK		
Z1, Z2, Z3, Z4, Z5, Z6, Z7, Z8	8		Bumpon, Cylindrical, 0.312 X 0.200, Black	Black Bumpon	SJ61A1	3M		
Z9, Z10, Z11	3		Screw, Pan Phillips, Nylon, 2-56		90272A146	B&F Fastener Supply		
Z12, Z13, Z14	3		Nut, Hex, 11/32 in Stainless Steel, 8-32		90631A007			
Z15, Z16, Z17, Z18	4		Mounting bracket for PCC-SMP		36-625-ND			
Z19	1		CABLE MINI USB 5PIN 1M 2.0 VERS		3025010-03			
Z20	1		CONN HOUSING 2POS. 100 W/LATCH		AWR1843EV M_Label.pdf			
Z21	1		CONN HOUSING 2POS. 100 W/LATCH		SSZZ027M.pdf			
Z22	1		CONN HOUSING 2POS. 100 W/LATCH		AWR1843EV M_QSG.pdf			

Table 11. Radar Board Bill of Materials (continued)

C83	0	10- μ F	CAP, CERM, 0805, X7S, 10-V, 10- μ F, \pm 10%	0805	CGA4J3X7S1 A106K	TDK Corporation		
D4	0	28-V	Diode, TVS, Bi, 28-V, 45.4 Vc, AEC-Q101, SOD-123	SOD-123	ATV02W280B -HF	Comchip Technology		
J12	0		Receptacle, 100-mil, 2x1, Gold, SMT	2x1 Receptacle	SSM-102-L-SV	Samtec		
LBL1	0		Thermal Transfer Printable Labels, 0.650-in W x 0.200-in H - 10,000 per roll	PCB Label 0.650 in H x 0.200 in W	THT-14-423-10	Brady	-	-
R21, R26, R33, R108, R109, R131, R135, R143, R164, R165, R166, R169, R196, R212, R214, R217	0	0	RES, 0, 5%, 0.05 W, 0201	0201	CRCW02010 000Z0ED	Vishay-Dale		
R34, R115	0	0	RES, 0, 5%, 0.75 W, AEC-Q200 Grade 0, 2010	2010	CRCW20100 000Z0EF	Vishay-Dale		
R83	0	0	RES, 0, 5%, 0.063 W, 0402	0402	CRCW04020 000Z0ED	Vishay-Dale		
R86, R160	0	10.0 k	RES, 10.0 k, 1%, 0.063 W, AEC-Q200 Grade 0, 0402	0402	CRCW04021 0K0FKED	Vishay-Dale		
R118	0	0	RES, 0, 5%, 0.063 W, 0402	0402	ERJ-2GE0R00X	Panasonic		
R137	0	0	RES, 0, 5%, 0.125 W, 0603	0603	MCT06030Z0 000ZP500	Vishay/Beys chlag		
R178, R223	0	10.0 k	RES, 10.0 k, 1%, 0.05 W, 0201	0201	CRCW02011 0K0FKED	Vishay-Dale		

8 References

1. Texas Instruments, [DCA1000EVM Data Capture Card](#).
2. Texas Instruments, [mmWave Software Development Kit \(SDK\)](#).
3. Texas Instruments, [TPS65313-Q1 Wide-VIN Power-Management IC for Automotive Applications](#).

IMPORTANT NOTICE AND DISCLAIMER

TI PROVIDES TECHNICAL AND RELIABILITY DATA (INCLUDING DATASHEETS), DESIGN RESOURCES (INCLUDING REFERENCE DESIGNS), APPLICATION OR OTHER DESIGN ADVICE, WEB TOOLS, SAFETY INFORMATION, AND OTHER RESOURCES "AS IS" AND WITH ALL FAULTS, AND DISCLAIMS ALL WARRANTIES, EXPRESS AND IMPLIED, INCLUDING WITHOUT LIMITATION ANY IMPLIED WARRANTIES OF MERCHANTABILITY, FITNESS FOR A PARTICULAR PURPOSE OR NON-INFRINGEMENT OF THIRD PARTY INTELLECTUAL PROPERTY RIGHTS.

These resources are intended for skilled developers designing with TI products. You are solely responsible for (1) selecting the appropriate TI products for your application, (2) designing, validating and testing your application, and (3) ensuring your application meets applicable standards, and any other safety, security, or other requirements. These resources are subject to change without notice. TI grants you permission to use these resources only for development of an application that uses the TI products described in the resource. Other reproduction and display of these resources is prohibited. No license is granted to any other TI intellectual property right or to any third party intellectual property right. TI disclaims responsibility for, and you will fully indemnify TI and its representatives against, any claims, damages, costs, losses, and liabilities arising out of your use of these resources.

TI's products are provided subject to TI's Terms of Sale (www.ti.com/legal/termsofsale.html) or other applicable terms available either on ti.com or provided in conjunction with such TI products. TI's provision of these resources does not expand or otherwise alter TI's applicable warranties or warranty disclaimers for TI products.

Mailing Address: Texas Instruments, Post Office Box 655303, Dallas, Texas 75265
Copyright © 2020, Texas Instruments Incorporated