

bq27426 Gauging Design for Applications With 2-S Li-Ion Battery

Phil Yi

Battery Management

ABSTRACT

The bq27426 gas gauge is designed to operate from a single-cell, lithium-ion or lithium-polymer battery. The applications that benefit from these gas gauges use two or more lithium cells in series where the battery voltage exceeds the single cell gas gauge bq27426 battery voltage measurement capability, which normally is equal to or less than 5 V. This application report describes a low-component-count solution for using the bq27421, bq27426, and bq27441 with 2-S (2 cells in series) battery.

Contents

1	Introduction	1
2	Implementation	2
3	Voltage Calibration and Accuracy	3
4	bq27426 Configuration and Learning Process.....	3
5	Cell Balancing Consideration.....	3

List of Figures

1	External Voltage Divider Using Operational Amplifier	2
---	--	---

List of Tables

1	Voltage Divider Accuracy After Calibration.....	3
---	---	---

Trademarks

Impedance Track is a trademark of Texas Instruments.

1 Introduction

Host-side application of a single-cell gas gauge, bq27426, requires direct battery voltage measurement from the battery pack. For a single-cell pack, the bq27426 uses the BAT pin to measure the pack voltage directly with the BAT pin internal translation circuits enabled. The maximum voltage that can be applied to the BAT pin is 5 V.

If a 2-S battery pack is used, the bq27426 cannot directly measure the battery voltage because the pack voltage may be much higher than the maximum operating voltage on the BAT pin. An external resistive voltage divider circuit is required to divide down the battery voltage to the range equivalent of a single-cell battery.

2 Implementation

The bq27426 BAT pin is designed not only for 2.45V to 4.50V directly voltage measurement with internal voltage divider enabled, but also it's the internal LDO regulator input pin. It's required to connect a 1- μ F capacitor to achieve 1-mV accuracy of voltage-measurement on the bq27426 BAT pin. This voltage measurement accuracy is required by the Impedance Track™ algorithm to have less than 1% state-of-charge error.

If an external resistive voltage divider is directly connected to the BAT pin, the external voltage divider network interferes with the internal voltage divider network and causes the voltage divider ratio to change so that the voltage measurement is not accurate. To prevent the interference, a unity-gain operational amplifier is used to buffer the output of the resistive voltage divider and provide a BAT voltage that is equal to the external voltage divider output. The micro-power operational amplifier generally has much higher input impedance than the internal voltage divider and reduces the voltage measurement error due to loading of the external voltage divider output.

The tolerance of the external voltage divider resistors has a direct impact on the voltage measurement error. A resistor with 0.1% tolerance is required. Considering the temperature range of the application, a temperature coefficient of 50 ppm/°C, or less, is also needed. The resistors must be of the same kind and from the same manufacturer.

The bq27426 gas gauge has typical current consumption of 50 μ A under normal operation. The peak current at start up can go up to 8 mA for a short period of time. To ensure the bq27426 starts up properly, the 1- μ F capacitor on the BAT pin is necessary, and so the operational amplifier shall have the capability to drive a high-capacitance load. With consideration of size, cost, and power consumption, TI's TS321IDBV is selected for this application.

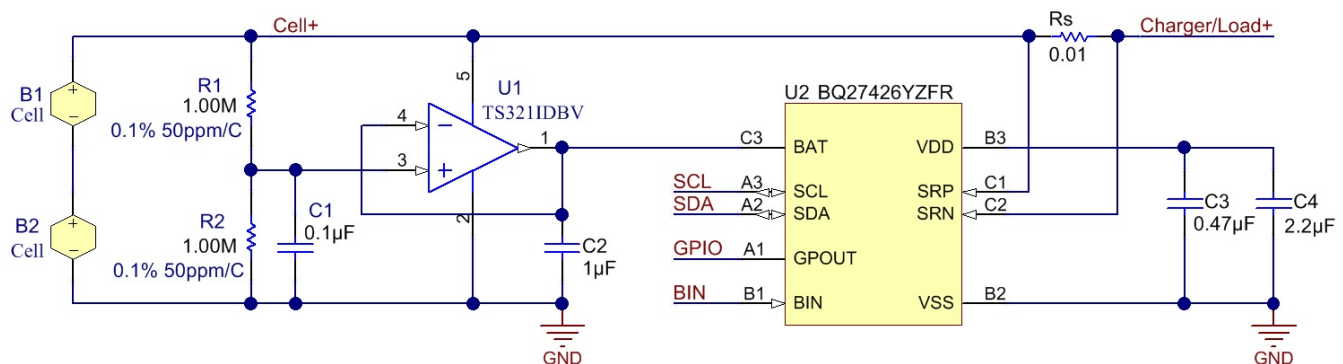

Figure 1. External Voltage Divider Using Operational Amplifier

3 Voltage Calibration and Accuracy

The internal voltage divider in the bq27426 is factory-calibrated to have 1-mV accuracy. The external voltage divider requires additional calibration.

For calibration, a calibrated voltage meter with resolution better than 1 mV is used. Apply a constant 8 V to the positive input of the voltage divider and read the voltage measured by the bq27426 gauge. The expected voltage should be 4 V. The difference is the offset error, and it can be stored in data flash inside the gauge.

To further investigate the impact of temperature and input voltage on the voltage divider offset and gain, a bq27426 for 2-S reference design evaluation module is built with this voltage divider circuit. Test is implemented with voltage input from 8.4 V down to 6 V with 200-mV increments at -10°C , 25°C and 50°C . The voltage measurement error across the temperature and voltage range after calibration is shown in [Table 1](#). The maximum voltage error due to the voltage divider is in the 1- to 2-mV range after calibration.

Table 1. Voltage Divider Accuracy After Calibration

-10°C				25°C				50°C			
Pack Voltage	Divided Voltage	Abs. Error	After Cal. Error	Pack Voltage	Divided Voltage	Abs. Error	After Cal. Error	Pack Voltage	Divided Voltage	Abs. Error	After Cal. Error
8.401	4.193	0.015	-0.001	8.401	4.192	0.017	0.001	8.401	4.192	0.017	0.001
8.201	4.093	0.015	-0.001	8.201	4.092	0.017	0.001	8.201	4.092	0.017	0.001
8.000	3.992	0.016	0.000	8.000	3.992	0.016	0.000	8.000	3.992	0.016	0.000
7.800	3.893	0.014	-0.002	7.800	3.892	0.016	0.000	7.800	3.892	0.016	0.000
7.600	3.792	0.016	0.000	7.600	3.792	0.016	0.000	7.600	3.792	0.016	0.000
7.400	3.693	0.014	-0.002	7.400	3.692	0.016	0.000	7.400	3.692	0.016	0.000
7.200	3.592	0.016	0.000	7.200	3.592	0.016	0.000	7.200	3.592	0.016	0.000
7.000	3.492	0.016	0.000	7.000	3.492	0.016	0.000	7.000	3.492	0.016	0.000
6.800	3.392	0.016	0.000	6.800	3.392	0.016	0.000	6.800	3.392	0.016	0.000
6.600	3.292	0.016	0.000	6.600	3.292	0.016	0.000	6.600	3.292	0.016	0.000
6.400	3.192	0.016	0.000	6.400	3.192	0.016	0.000	6.400	3.192	0.016	0.000
6.200	3.093	0.014	-0.002	6.200	3.093	0.014	-0.002	6.200	3.092	0.016	0.000
6.000	2.993	0.014	-0.002	6.000	2.993	0.014	-0.002	6.000	2.992	0.016	0.000

Unit: volts

4 bq27426 Configuration and Learning Process

The gas gauge configuration and learning process is identical to that of a single-cell application. Equivalently, the bq27426 is operating from a single cell. Gauge current sensing is not affected by a 2-S battery. The battery internal impedance calculation is still valid. The total capacity of the 2-S is the same as that of a single-cell capacity. If a 1-mV accuracy voltage measurement is maintained, the overall accuracy of the gauge for 2-S battery is the same as for a single cell. The data flash configuration and the learned data flash image from a single cell can be used for the same cell in a 2-S configuration.

5 Cell Balancing Consideration

The bq27426 device has no cell-balancing capability, and the use of a voltage divider does not provide any individual cell information. Therefore, is up to the pack maker and the original equipment manufacturer to make sure that the 2 cells in series are not out of balance and that the safety of the pack is maintained.

IMPORTANT NOTICE FOR TI DESIGN INFORMATION AND RESOURCES

Texas Instruments Incorporated ("TI") technical, application or other design advice, services or information, including, but not limited to, reference designs and materials relating to evaluation modules, (collectively, "TI Resources") are intended to assist designers who are developing applications that incorporate TI products; by downloading, accessing or using any particular TI Resource in any way, you (individually or, if you are acting on behalf of a company, your company) agree to use it solely for this purpose and subject to the terms of this Notice.

TI's provision of TI Resources does not expand or otherwise alter TI's applicable published warranties or warranty disclaimers for TI products, and no additional obligations or liabilities arise from TI providing such TI Resources. TI reserves the right to make corrections, enhancements, improvements and other changes to its TI Resources.

You understand and agree that you remain responsible for using your independent analysis, evaluation and judgment in designing your applications and that you have full and exclusive responsibility to assure the safety of your applications and compliance of your applications (and of all TI products used in or for your applications) with all applicable regulations, laws and other applicable requirements. You represent that, with respect to your applications, you have all the necessary expertise to create and implement safeguards that (1) anticipate dangerous consequences of failures, (2) monitor failures and their consequences, and (3) lessen the likelihood of failures that might cause harm and take appropriate actions. You agree that prior to using or distributing any applications that include TI products, you will thoroughly test such applications and the functionality of such TI products as used in such applications. TI has not conducted any testing other than that specifically described in the published documentation for a particular TI Resource.

You are authorized to use, copy and modify any individual TI Resource only in connection with the development of applications that include the TI product(s) identified in such TI Resource. NO OTHER LICENSE, EXPRESS OR IMPLIED, BY ESTOPPEL OR OTHERWISE TO ANY OTHER TI INTELLECTUAL PROPERTY RIGHT, AND NO LICENSE TO ANY TECHNOLOGY OR INTELLECTUAL PROPERTY RIGHT OF TI OR ANY THIRD PARTY IS GRANTED HEREIN, including but not limited to any patent right, copyright, mask work right, or other intellectual property right relating to any combination, machine, or process in which TI products or services are used. Information regarding or referencing third-party products or services does not constitute a license to use such products or services, or a warranty or endorsement thereof. Use of TI Resources may require a license from a third party under the patents or other intellectual property of the third party, or a license from TI under the patents or other intellectual property of TI.

TI RESOURCES ARE PROVIDED "AS IS" AND WITH ALL FAULTS. TI DISCLAIMS ALL OTHER WARRANTIES OR REPRESENTATIONS, EXPRESS OR IMPLIED, REGARDING TI RESOURCES OR USE THEREOF, INCLUDING BUT NOT LIMITED TO ACCURACY OR COMPLETENESS, TITLE, ANY EPIDEMIC FAILURE WARRANTY AND ANY IMPLIED WARRANTIES OF MERCHANTABILITY, FITNESS FOR A PARTICULAR PURPOSE, AND NON-INFRINGEMENT OF ANY THIRD PARTY INTELLECTUAL PROPERTY RIGHTS.

TI SHALL NOT BE LIABLE FOR AND SHALL NOT DEFEND OR INDEMNIFY YOU AGAINST ANY CLAIM, INCLUDING BUT NOT LIMITED TO ANY INFRINGEMENT CLAIM THAT RELATES TO OR IS BASED ON ANY COMBINATION OF PRODUCTS EVEN IF DESCRIBED IN TI RESOURCES OR OTHERWISE. IN NO EVENT SHALL TI BE LIABLE FOR ANY ACTUAL, DIRECT, SPECIAL, COLLATERAL, INDIRECT, PUNITIVE, INCIDENTAL, CONSEQUENTIAL OR EXEMPLARY DAMAGES IN CONNECTION WITH OR ARISING OUT OF TI RESOURCES OR USE THEREOF, AND REGARDLESS OF WHETHER TI HAS BEEN ADVISED OF THE POSSIBILITY OF SUCH DAMAGES.

You agree to fully indemnify TI and its representatives against any damages, costs, losses, and/or liabilities arising out of your non-compliance with the terms and provisions of this Notice.

This Notice applies to TI Resources. Additional terms apply to the use and purchase of certain types of materials, TI products and services. These include; without limitation, TI's standard terms for semiconductor products (<http://www.ti.com/sc/docs/stdterms.htm>), [evaluation modules](#), and [samples](http://www.ti.com/sc/docs/sampterm.htm) (<http://www.ti.com/sc/docs/sampterm.htm>).

Mailing Address: Texas Instruments, Post Office Box 655303, Dallas, Texas 75265
Copyright © 2017, Texas Instruments Incorporated