

# AN100 - Crystal Selection Guide

Fredrik Kervel

## ABSTRACT

RF systems are highly dependent on accurate clocks for correct operation. A deviation in clock frequency is directly reflected as a deviation in radio frequency. This can degrade RF performance, violate legal requirements or in worst case lead to a non-functioning system.

The scope of this application report is to give the design engineer a quick guide on how to design, tune and verify the clock circuit for TI's LPRF products. A list of suggested crystals that can be used with CC253x and CC254x is presented. The designer must pick a crystal that satisfies their requirements on size, tolerance and temperature range. If other crystals are to be used, fundamental mode, AT cut crystals is highly recommended due to accuracy and ease of use.

## Contents

1	Crystal Oscillator Theory .....	2
2	Selecting Crystals .....	4
3	References .....	5

## List of Figures

1	Pierce Oscillator.....	2
2	Startup Time vs. Added Series Resistance [FA-128 on CC2540EM].....	3
3	FREQTUNE Pullability Example .....	4
4	Startup Time vs. FREQTUNE Setting.....	4

## 1 Crystal Oscillator Theory

### 1.1 Oscillator Operation

The circuit used as high frequency, high accuracy clock source for TI's low power RF products is called a "Pierce Oscillator" and is shown in Figure 1. The oscillator circuit consists of an inverting amplifier (normally a regular inverter), a feedback resistor, two capacitors and a crystal. The first two components are internal in the IC while the capacitors and the crystal are external and must be selected for each separate design.

During normal operation, the crystal and the capacitors form a pi filter providing 180° phase shift to the internal amplifier, thus keeping the oscillator locked at the specified frequency.

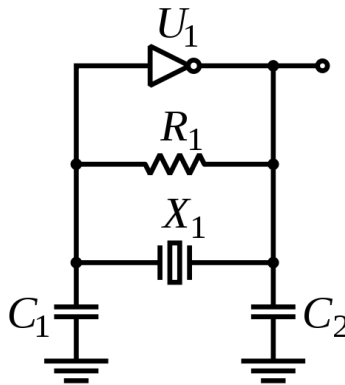

Figure 1. Pierce Oscillator

### 1.2 Crystal Tolerance

The total tolerance of a Crystal is dependent on three factors: production tolerance, temperature tolerance and age. All of these values are given in [ppm] (parts per million) and can be found in the manufacturer's data sheet. To get the total maximum tolerance of a certain crystal all these factors must be accounted for.

Crystal frequency deviation is directly transferred to RF deviation, thus a deviation in the crystal oscillator frequency of X ppm leads a deviation in carrier frequency of X ppm. Therefore, it is important to select a crystal with performance within the limits of the RF specifications. Of course, the end products expected age and operating conditions (temperature) must be taken into consideration.

For 802.15.4 (RF4CE), the max deviation in carrier frequency is limited to 40 ppm. [1]

For Bluetooth Low Energy, the limit is 40 ppm. [2]

### 1.3 Load Capacitance

Correct operation of the crystal oscillator is dependent on the values of the two external capacitors,  $C_1$  and  $C_2$  in Figure 1. These capacitors together with any parasitic capacitance in the PCB and the crystal terminals compose the total load capacitance seen by the crystal. The optimum load capacitance for the crystal,  $C_L$ , is given in the crystal datasheet and  $C_1$  and  $C_2$  should be matched to this value according to Equation 1:

$$C_L = \frac{C_1' \cdot C_2'}{C_1' + C_2'} \quad (1)$$

Where,  $C_x'$  is the sum of the capacitance in  $C_x$ , the parasitic capacitance in the PCB trace and the capacitance in the terminal of the crystal. The sum of the two latter parts will typically be in the range of 2 – 8 pF.

The easiest way to find the optimum load capacitor values for a given circuit and layout is through experiments. The radio can be set to put out a constant carrier at a given frequency with SmartRF Studio. By measuring the output frequency with a Spectrum Analyzer, the offset can easily be found.

### 1.4 $R_S$ (ESR) and Negative Resistance

$R_S$  or equivalent series resistance (ESR) is a parameter of the crystal, which can be found in the device-specific data sheet. Negative resistance is a parameter of the complete oscillator circuit, including capacitor values, crystal parameters and on-chip circuit. To ensure correct function of the crystal oscillator, negative resistance should be at least 5 times greater than  $R_S$ .

$$R_S < \frac{R_{neg}}{5} \tag{2}$$

If this is not true the oscillator might not operate as expected or it might not start up at all.

The negative resistance of the circuit can be found by introducing a resistor in series with the crystal. To avoid parasitic effects it is recommended to use a 0201 resistor for this task. The threshold of resistance where the oscillator is no longer able to start up is approximately the same as the circuit negative resistance. An example of resistance vs. startup time and negative resistance threshold is shown in Figure 2.

Note that higher load capacitor values decreases the negative resistance and rises the startup time.

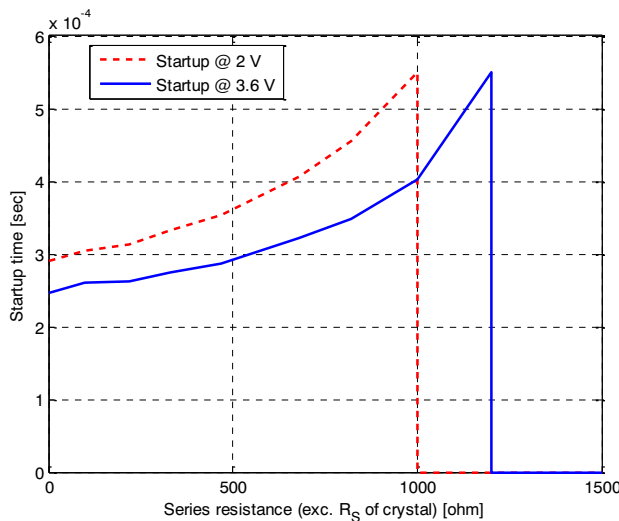

Figure 2. Startup Time vs. Added Series Resistance [FA-128 on CC2540EM]

### 1.5 FREQTUNE Register

The CC253x and CC254x radios have the possibility to add extra load capacitance on-chip for oscillator frequency tuning. The capacitance value is adjusted by the 4 last bits (3:0) of the 'FREQTUNE' register. The default value of the register is 0x0F which corresponds to no added capacitance. For each decrement in the register value, extra capacitance is added to the oscillator circuit, reducing the oscillator frequency.

The level of tuning possible, also known as pullability, will differ from crystal to crystal as shown in Figure 3. Some manufacturers present this value in the data sheet given in ppm/pF.

Note that parameters as  $R_{neg}$  and startup time are dependent on the load capacitance, so changing FREQTUNE value also changes these parameters. Figure 4 shows how startup time will vary with added load capacitance.

In both Figure 3 and Figure 4 the load capacitance is tuned such that FREQTUNE = 0x0F corresponds to approximately 0 ppm offset from correct center frequency.

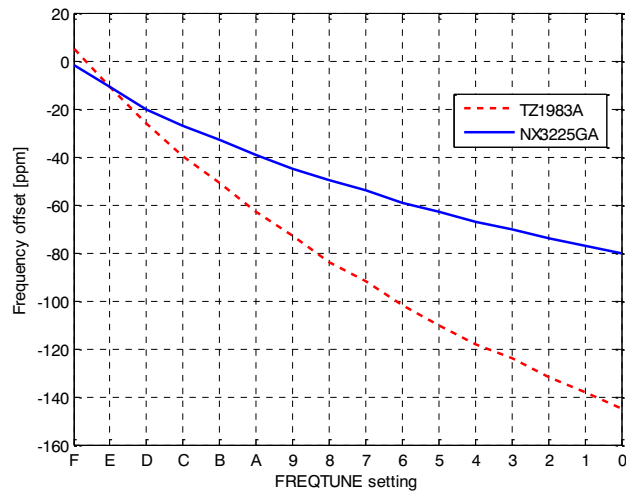
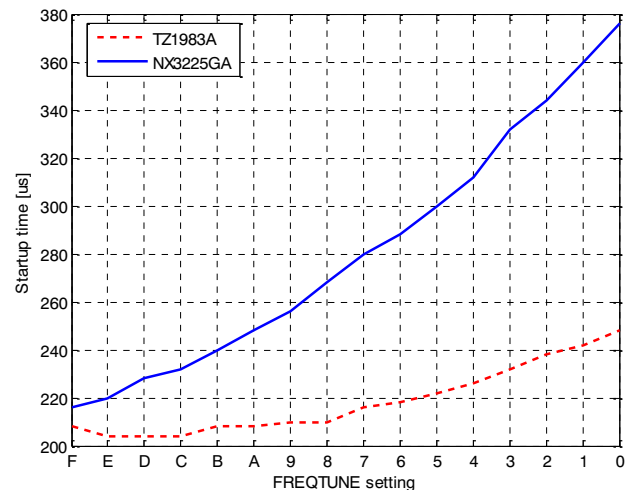
**Figure 3. FREQTUNE Pullability Example**

**Figure 4. Startup Time vs. FREQTUNE Setting**

## 2 Selecting Crystals

Some suggested crystals are presented in [Table 1](#) and [Table 2](#). These crystals are tested with the CC2540 on the two EVM boards “CC2540EM Crystal Eval” and “CC2540EM HC49smd Eval”. The first board has footprints for crystals varying in size from 2016 through 4025 while the latter board has footprints for HC49smd crystals.

Although the tests have been performed with CC2540, the crystals will have similar performance on any CC253x or CC254x devices as well.

The crystals are listed with their key data sheet values in [Table 1](#). [Table 2](#) contains data measured on TI's EVMs.

Note that measured data will differ from board to board as a result of layout and PCB characteristics. The capacitor values presented are valid for the TI crystal evaluation boards; other values might be needed on other boards.

Selecting crystals for a specific application will often be dependent on three factors: size (footprint area, height), performance (accuracy over temperature, lifetime) and cost (for example, higher performance and smaller package = higher price).

**Table 1. Data Sheet Values**

Manufacturer	MPN	Package	ESR ( $\Omega$ )	CL (pF)	freq (MHz)	Tolerance (ppm)	Temp Tolerance (ppm)	Again (ppm/year)	Temp Range [°C]
Epson Toyocom	FA-128	2016	60	10	32	10	10	5	85 -40
Epson Toyocom	FA-20H	2520	60	10	32	10	10	3	85 -40
NDK	NX3225GA	3225	50	12	32	20	30		85 -40
NDK	NX3225JA	3225	60	10	32	20	20		70 0
Tai-Saw Technology	TZ1983A	HC49smd	50	10	32	10	20	1	70 0

**Table 2. Measurements on TI EM @25°C**

MPN	C231	C221	Startup time		Negative Resistance	FREQTUNE Pullability
			2 V	3 V		
FA-128	12 pF	12 pF	290 $\mu$ s	251 $\mu$ s	1k $\Omega$	-54 ppm
FA-20H	12 pF	12 pF	408 $\mu$ s	352 $\mu$ s		-35 ppm
NX3225GA	12 pF	15 pF	236 $\mu$ s	216 vs	820 > R <sub>neg</sub> > 680	-78 ppm
TZ1983A	10 pF	12 PF	228 $\mu$ s	208 $\mu$ s		-150 ppm

### 3 References

1. IEEE Standards Association 802.15.4-2006 ([IEEE download](#))
2. IEEE Get Program 802.15.1-2005 ([IEEE download](#))

## IMPORTANT NOTICE

Texas Instruments Incorporated and its subsidiaries (TI) reserve the right to make corrections, enhancements, improvements and other changes to its semiconductor products and services per JESD46, latest issue, and to discontinue any product or service per JESD48, latest issue. Buyers should obtain the latest relevant information before placing orders and should verify that such information is current and complete. All semiconductor products (also referred to herein as "components") are sold subject to TI's terms and conditions of sale supplied at the time of order acknowledgment.

TI warrants performance of its components to the specifications applicable at the time of sale, in accordance with the warranty in TI's terms and conditions of sale of semiconductor products. Testing and other quality control techniques are used to the extent TI deems necessary to support this warranty. Except where mandated by applicable law, testing of all parameters of each component is not necessarily performed.

TI assumes no liability for applications assistance or the design of Buyers' products. Buyers are responsible for their products and applications using TI components. To minimize the risks associated with Buyers' products and applications, Buyers should provide adequate design and operating safeguards.

TI does not warrant or represent that any license, either express or implied, is granted under any patent right, copyright, mask work right, or other intellectual property right relating to any combination, machine, or process in which TI components or services are used. Information published by TI regarding third-party products or services does not constitute a license to use such products or services or a warranty or endorsement thereof. Use of such information may require a license from a third party under the patents or other intellectual property of the third party, or a license from TI under the patents or other intellectual property of TI.

Reproduction of significant portions of TI information in TI data books or data sheets is permissible only if reproduction is without alteration and is accompanied by all associated warranties, conditions, limitations, and notices. TI is not responsible or liable for such altered documentation. Information of third parties may be subject to additional restrictions.

Resale of TI components or services with statements different from or beyond the parameters stated by TI for that component or service voids all express and any implied warranties for the associated TI component or service and is an unfair and deceptive business practice. TI is not responsible or liable for any such statements.

Buyer acknowledges and agrees that it is solely responsible for compliance with all legal, regulatory and safety-related requirements concerning its products, and any use of TI components in its applications, notwithstanding any applications-related information or support that may be provided by TI. Buyer represents and agrees that it has all the necessary expertise to create and implement safeguards which anticipate dangerous consequences of failures, monitor failures and their consequences, lessen the likelihood of failures that might cause harm and take appropriate remedial actions. Buyer will fully indemnify TI and its representatives against any damages arising out of the use of any TI components in safety-critical applications.

In some cases, TI components may be promoted specifically to facilitate safety-related applications. With such components, TI's goal is to help enable customers to design and create their own end-product solutions that meet applicable functional safety standards and requirements. Nonetheless, such components are subject to these terms.

No TI components are authorized for use in FDA Class III (or similar life-critical medical equipment) unless authorized officers of the parties have executed a special agreement specifically governing such use.

Only those TI components which TI has specifically designated as military grade or "enhanced plastic" are designed and intended for use in military/aerospace applications or environments. Buyer acknowledges and agrees that any military or aerospace use of TI components which have **not** been so designated is solely at the Buyer's risk, and that Buyer is solely responsible for compliance with all legal and regulatory requirements in connection with such use.

TI has specifically designated certain components as meeting ISO/TS16949 requirements, mainly for automotive use. In any case of use of non-designated products, TI will not be responsible for any failure to meet ISO/TS16949.

### Products

Audio	<a href="http://www.ti.com/audio">www.ti.com/audio</a>
Amplifiers	<a href="http://amplifier.ti.com">amplifier.ti.com</a>
Data Converters	<a href="http://dataconverter.ti.com">dataconverter.ti.com</a>
DLP® Products	<a href="http://www.dlp.com">www.dlp.com</a>
DSP	<a href="http://dsp.ti.com">dsp.ti.com</a>
Clocks and Timers	<a href="http://www.ti.com/clocks">www.ti.com/clocks</a>
Interface	<a href="http://interface.ti.com">interface.ti.com</a>
Logic	<a href="http://logic.ti.com">logic.ti.com</a>
Power Mgmt	<a href="http://power.ti.com">power.ti.com</a>
Microcontrollers	<a href="http://microcontroller.ti.com">microcontroller.ti.com</a>
RFID	<a href="http://www.ti-rfid.com">www.ti-rfid.com</a>
OMAP Applications Processors	<a href="http://www.ti.com/omap">www.ti.com/omap</a>
Wireless Connectivity	<a href="http://www.ti.com/wirelessconnectivity">www.ti.com/wirelessconnectivity</a>

### Applications

Automotive and Transportation	<a href="http://www.ti.com/automotive">www.ti.com/automotive</a>
Communications and Telecom	<a href="http://www.ti.com/communications">www.ti.com/communications</a>
Computers and Peripherals	<a href="http://www.ti.com/computers">www.ti.com/computers</a>
Consumer Electronics	<a href="http://www.ti.com/consumer-apps">www.ti.com/consumer-apps</a>
Energy and Lighting	<a href="http://www.ti.com/energy">www.ti.com/energy</a>
Industrial	<a href="http://www.ti.com/industrial">www.ti.com/industrial</a>
Medical	<a href="http://www.ti.com/medical">www.ti.com/medical</a>
Security	<a href="http://www.ti.com/security">www.ti.com/security</a>
Space, Avionics and Defense	<a href="http://www.ti.com/space-avionics-defense">www.ti.com/space-avionics-defense</a>
Video and Imaging	<a href="http://www.ti.com/video">www.ti.com/video</a>

### TI E2E Community

[e2e.ti.com](http://e2e.ti.com)