

# DRV8885 1.5-A Stepper Motor Driver With Integrated Current Sense

## 1 Features

- PWM microstepping stepper motor driver
  - Up to 1/16 microstepping
  - Non-circular and standard ½ step modes
- Integrated current sense functionality
  - No sense resistors required
  - ±6.25% Full-scale current accuracy
- Slow and mixed decay options
- 8.0- to 37-V Operating supply voltage range
- Low  $R_{DS(ON)}$ : 0.86  $\Omega$  HS + LS at 24 V, 25°C
- High current capacity
  - 1.5-A Full scale per bridge
  - 1.0-A rms per bridge
- Fixed off-time PWM chopping
- Simple STEP/DIR interface
- Low-current sleep mode (20  $\mu$ A)
- Small package and footprint
  - 24 HTSSOP PowerPAD™ package
  - 28 WQFN package
- Protection features
  - VM undervoltage lockout (UVLO)
  - Charge pump undervoltage (CPUV)
  - Overcurrent protection (OCP)
  - Thermal shutdown (TSD)
  - Fault condition indication pin (nFAULT)

## 2 Applications

- [Multi-function printers](#) and [scanners](#)
- [Laser beam printers](#)
- [3D printers](#)
- [Automatic teller](#) and [money handling machines](#)
- [Video security cameras](#)
- [Office automation machines](#)
- [Factory automation and robotics](#)

## 3 Description

The DRV8885 is a stepper motor driver for industrial equipment applications. The device has two N-channel power MOSFET H-bridge drivers, a microstepping indexer, and integrated current sense. The DRV8885 is capable of driving up to 1.5 A full scale or 1.0 A rms output current (depending on proper PCB ground plane for thermal dissipation and at 24 V and  $T_A = 25^\circ\text{C}$ ).

The DRV8885 integrated current sense functionality eliminates the need for two external sense resistors.

The STEP/DIR pins provide a simple control interface. The device can be configured in full-step up to 1/16 step modes. A low-power sleep mode is provided for very-low quiescent current standby using a dedicated nSLEEP pin.

Internal protection functions are provided for undervoltage, charge pump faults, overcurrent, short circuits, and overtemperature. Fault conditions are indicated by an nFAULT pin.

### Device Information (1)

PART NUMBER	PACKAGE	BODY SIZE (NOM)
DRV8885	HTSSOP (24)	7.80 mm x 4.40 mm
	WQFN (28)	5.50 mm x 3.5 mm

(1) For all available packages, see the orderable addendum at the end of the data sheet.

### Simplified Schematic

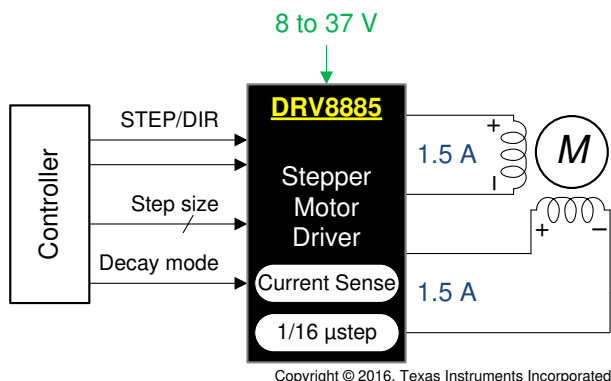

### Microstepping Current Waveform

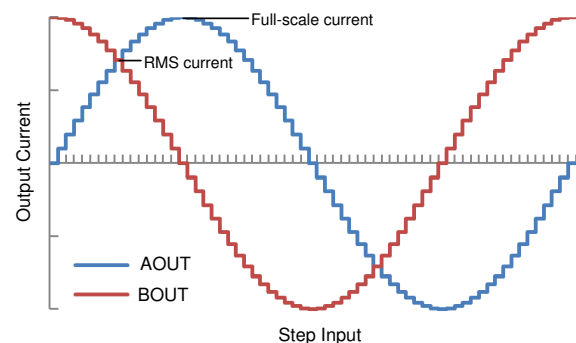

## Table of Contents

<b>1 Features</b> .....	<b>1</b>	7.4 Device Functional Modes.....	<b>31</b>
<b>2 Applications</b> .....	<b>1</b>	<b>8 Application and Implementation</b> .....	<b>32</b>
<b>3 Description</b> .....	<b>1</b>	8.1 Application Information.....	<b>32</b>
<b>4 Revision History</b> .....	<b>2</b>	8.2 Typical Application .....	<b>32</b>
<b>5 Pin Configuration and Functions</b> .....	<b>3</b>	<b>9 Power Supply Recommendations</b> .....	<b>35</b>
<b>6 Specifications</b> .....	<b>4</b>	9.1 Bulk Capacitance .....	<b>35</b>
6.1 Absolute Maximum Ratings .....	<b>4</b>	<b>10 Layout</b> .....	<b>36</b>
6.2 ESD Ratings.....	<b>4</b>	10.1 Layout Guidelines .....	<b>36</b>
6.3 Recommended Operating Conditions.....	<b>5</b>	10.2 Layout Example .....	<b>36</b>
6.4 Thermal Information .....	<b>5</b>	<b>11 Device and Documentation Support</b> .....	<b>37</b>
6.5 Electrical Characteristics.....	<b>6</b>	11.1 Documentation Support .....	<b>37</b>
6.6 Indexer Timing Requirements.....	<b>8</b>	11.2 Receiving Notification of Documentation Updates	<b>37</b>
6.7 Typical Characteristics .....	<b>9</b>	11.3 Community Resources.....	<b>37</b>
<b>7 Detailed Description</b> .....	<b>11</b>	11.4 Trademarks .....	<b>37</b>
7.1 Overview .....	<b>11</b>	11.5 Electrostatic Discharge Caution.....	<b>37</b>
7.2 Functional Block Diagram .....	<b>12</b>	11.6 Glossary .....	<b>37</b>
7.3 Feature Description.....	<b>13</b>	<b>12 Mechanical, Packaging, and Orderable Information</b> .....	<b>37</b>

## 4 Revision History

NOTE: Page numbers for previous revisions may differ from page numbers in the current version.

<b>Changes from Revision C (November 2018) to Revision D</b>	<b>Page</b>
• Added <a href="#">Various Sources of Error</a> and <a href="#">Application-Specific Error Calculations</a> .....	<b>18</b>

---

<b>Changes from Revision B (July 2018) to Revision C</b>	<b>Page</b>
• Changed device status from Advance Information to Production Data.....	<b>1</b>

---

<b>Changes from Revision A (April 2016) to Revision B</b>	<b>Page</b>
• Added the WQFN package option.....	<b>1</b>
• Deleted <i>and internal indexer</i> from the description of the ENABLE pin in the <i>Pin Functions</i> table.....	<b>3</b>
• Changed <i>until ENABLE is deasserted</i> to <i>until ENABLE is asserted</i> in the <i>Device Functional Modes</i> section .....	<b>31</b>
• Added the <i>Receiving Notification of Documentation Updates</i> section .....	<b>37</b>

---

<b>Changes from Original (October 2015) to Revision A</b>	<b>Page</b>
• Updated peak drive current based on OCP .....	<b>4</b>
• Updated $R_{PD}$ and $R_{PU}$ values .....	<b>6</b>
• Fixed chopping current equation .....	<b>18</b>
• Added "Controlling RREF with a PWM Resource" .....	<b>18</b>
• Fixed resistance values in tri-level input pin diagram.....	<b>29</b>

## 5 Pin Configuration and Functions

**PWP PowerPAD™ Package  
24-Pin HTSSOP  
Top View**

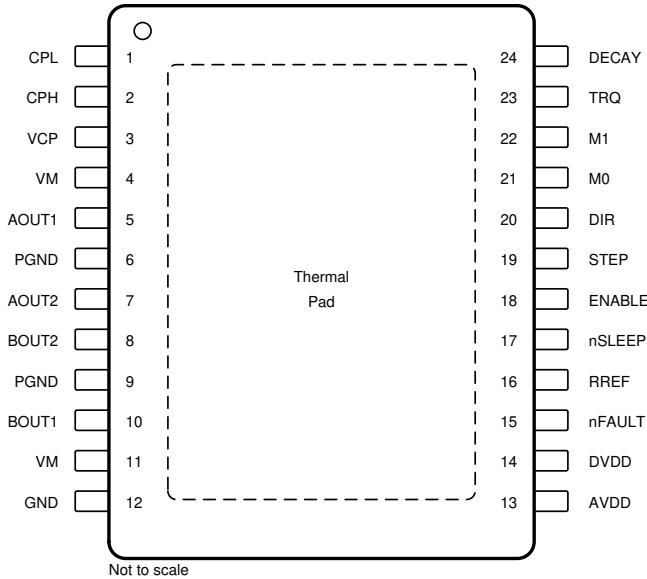

**RHR Package  
28-Pin WQFN With Exposed Thermal Pad  
Top View**

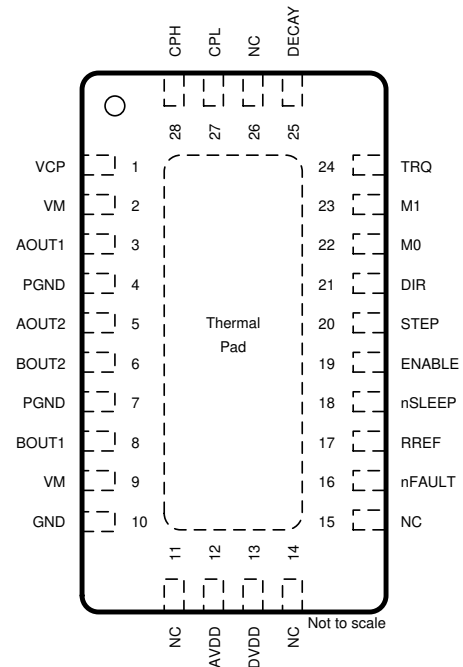

### Pin Functions

NAME	PIN NO.		TYPE <sup>(1)</sup>	DESCRIPTION
	HTSSOP	WQFN		
AOUT1	5	3	O	Winding A output. Connect to stepper motor winding.
AOUT2	7	5		
AVDD	13	12	PWR	Internal regulator. Bypass to GND with a X5R or X7R, 0.47- $\mu$ F, 6.3-V ceramic capacitor.
BOUT1	10	8	O	Winding B output. Connect to stepper motor winding.
BOUT2	8	6		
CPH	2	28	PWR	Charge pump switching node. Connect a X5R or X7R, 0.022- $\mu$ F, VM-rated ceramic capacitor from CPH to CPL.
CPL	1	27		
DECAY	24	25	I	Decay-mode setting. Sets the decay mode (see the <a href="#">Decay Modes</a> section). Decay mode can be adjusted during operation.
DIR	20	21	I	Direction input. Logic level sets the direction of stepping; internal pulldown resistor.
DVDD	14	13	PWR	Internal regulator. Bypass to GND with a X5R or X7R, 0.47- $\mu$ F, 6.3-V ceramic capacitor.
ENABLE	18	19	I	Enable driver input. Logic high to enable device outputs; logic low to disable; internal pulldown resistor.
GND	12	10	PWR	Device ground. Connect to system ground.
M0	21	22	I	Microstepping mode-setting. Sets the step mode; tri-level pins; sets the step mode; internal pulldown resistor.
M1	22	23		
NC	—	11	—	No connect. No internal connection
		14		
		15		
		26		
PGND	6	4	PWR	Power ground. Connect to system ground.
	9	7		
RREF	16	17	I	Current-limit analog input. Connect a resistor to ground to set full-scale regulation current.

(1) I = input, O = output, PWR = power, OD = open-drain

### Pin Functions (continued)

NAME	PIN NO.		TYPE <sup>(1)</sup>	DESCRIPTION
	HTSSOP	WQFN		
	STEP	19		
TRQ	23	24	I	Current-scaling control. Scales the output current; tri-level pin.
VCP	3	1	PWR	Charge pump output. Connect a X5R or X7R, 0.22- $\mu$ F, 16-V ceramic capacitor to VM.
VM	4	2	PWR	Power supply. Connect to motor supply voltage and bypass to GND with two 0.01- $\mu$ F ceramic capacitors (one for each pin) plus a bulk capacitor rated for VM.
	11	9		
nFAULT	15	16	OD	Fault indication. Pulled logic low with fault condition; open-drain output requires an external pullup resistor.
nSLEEP	17	18	I	Sleep mode input. Logic high to enable device; logic low to enter low-power sleep mode; internal pulldown resistor.

## 6 Specifications

### 6.1 Absolute Maximum Ratings

over operating free-air temperature range (unless otherwise noted) <sup>(1)</sup>

	MIN	MAX	UNIT
Power supply voltage (VM)	-0.3	40	V
Power supply voltage ramp rate (VM)	0	2	V/ $\mu$ s
Charge pump voltage (VCP, CPH)	-0.3	VM + 7	V
Charge pump negative switching pin (CPL)	-0.3	VM	V
Internal regulator voltage (DVDD)	-0.3	3.8	V
Internal regulator current output (DVDD)	0	1	mA
Internal regulator voltage (AVDD)	-0.3	5.7	V
Control pin voltage (STEP, DIR, ENABLE, nFAULT, M0, M1, DECAY, TRQ, nSLEEP)	-0.3	5.7	V
Open drain output current (nFAULT)	0	10	mA
Current limit input pin voltage (RREF)	-0.3	6.0	V
Continuous phase node pin voltage (AOUT1, AOUT2, BOUT1, BOUT2)	-0.7	VM + 0.7	V
Peak drive current (AOUT1, AOUT2, BOUT1, BOUT2)		2.3	A
Operating junction temperature, T <sub>J</sub>	-40	150	°C
Storage temperature, T <sub>stg</sub>	-65	150	°C

(1) Stresses beyond those listed under *Absolute Maximum Ratings* may cause permanent damage to the device. These are stress ratings only, which do not imply functional operation of the device at these or any other conditions beyond those indicated under *Recommended Operating Conditions*. Exposure to absolute-maximum-rated conditions for extended periods may affect device reliability.

### 6.2 ESD Ratings

		VALUE	UNIT
V <sub>(ESD)</sub> Electrostatic discharge	Human-body model (HBM), per ANSI/ESDA/JEDEC JS-001 <sup>(1)</sup>	±2000	V
	Charged-device model (CDM), per JEDEC specification JESD22-C101 <sup>(2)</sup>	±500	

(1) JEDEC document JEP155 states that 500-V HBM allows safe manufacturing with a standard ESD control process.

(2) JEDEC document JEP157 states that 250-V CDM allows safe manufacturing with a standard ESD control process.

### 6.3 Recommended Operating Conditions

over operating free-air temperature range (unless otherwise noted)

		MIN	MAX	UNIT
VM	Power supply voltage range	8	37	V
VCC	Logic level input voltage	0	5.3	V
$f_{PWM}$	Applied STEP signal (STEP)	0	100 <sup>(1)</sup>	kHz
$I_{DVDD}$	DVDD external load current	0	1 <sup>(2)</sup>	mA
$I_{FS}$	Motor full scale current	0	1.5	A
$I_{rms}$	Motor rms current	0	1.0	A
$T_A$	Operating ambient temperature	-40	125	°C

(1) STEP input can operate up to 500 kHz, but system bandwidth is limited by the motor load

(2) Power dissipation and thermal limits must be observed

### 6.4 Thermal Information

THERMAL METRIC <sup>(1)</sup>	DRV8885		UNIT	
	PWP (HTSSOP)	RHR (WQFN)		
	24 PINS	28 PINS		
$R_{\theta JA}$	Junction-to-ambient thermal resistance	36.1	33.6	°C/W
$R_{\theta JC(top)}$	Junction-to-case (top) thermal resistance	18.3	23.8	°C/W
$R_{\theta JB}$	Junction-to-board thermal resistance	15.8	12.7	°C/W
$\psi_{JT}$	Junction-to-top characterization parameter	0.4	0.3	°C/W
$\psi_{JB}$	Junction-to-board characterization parameter	15.7	12.6	°C/W
$R_{\theta JC(bot)}$	Junction-to-case (bottom) thermal resistance	1.1	3.7	°C/W

(1) For more information about traditional and new thermal metrics, see the [Semiconductor and IC Package Thermal Metrics application report](#).

## 6.5 Electrical Characteristics

over operating free-air temperature range (unless otherwise noted)

PARAMETER		TEST CONDITIONS	MIN	TYP	MAX	UNIT
<b>POWER SUPPLIES (VM, DVDD, AVDD)</b>						
V <sub>VM</sub>	VM operating voltage		8		37	V
I <sub>VM</sub>	VM operating supply current	VM ≈ 8 to 35 V, ENABLE = 1, nSLEEP = 1, No motor load		5	8	mA
I <sub>VMQ</sub>	VM sleep mode supply current	nSLEEP = 0; T <sub>A</sub> = 25°C			20	μA
		nSLEEP = 0; T <sub>A</sub> = 125°C <sup>(1)</sup>			40	
t <sub>SLEEP</sub>	Sleep time	nSLEEP = 0 to sleep-mode		50	200	μs
t <sub>WAKE</sub>	Wake-up time	nSLEEP = 1 to output transition		0.85	1.5	ms
t <sub>ON</sub>	Turn-on time	VM > UVLO to output transition		0.85	1.5	ms
V <sub>DVDD</sub>	Internal regulator voltage	0- to 1-mA external load	2.9	3.3	3.6	V
V <sub>AVDD</sub>	Internal regulator voltage	No external load	4.5	5.0	5.5	V
<b>CHARGE PUMP (VCP, CPH, CPL)</b>						
V <sub>VCP</sub>	VCP operating voltage	VM > 8 V		VM + 5.5		V
<b>LOGIC-LEVEL INPUTS (STEP, DIR, ENABLE, nSLEEP, M1)</b>						
V <sub>IL</sub>	Input logic low voltage		0		0.8	V
V <sub>IH</sub>	Input logic high voltage		1.6		5.3	V
V <sub>HYS</sub>	Input logic hysteresis		100			mV
I <sub>IL</sub>	Input logic low current	V <sub>IN</sub> = 0 V	-1		1	μA
I <sub>IH</sub>	Input logic high current	V <sub>IN</sub> = 5.0 V			100	μA
R <sub>PD</sub>	Pulldown resistance	To GND		100		kΩ
t <sub>PD</sub>	Propagation delay	STEP to current change			1.2	μs
<b>TRI-LEVEL INPUT (M0, TRQ)</b>						
V <sub>IL</sub>	Tri-level input logic low voltage		0		0.65	V
V <sub>IZ</sub>	Tri-level input Hi-Z voltage			1.1		V
V <sub>IH</sub>	Tri-level input logic high voltage		1.5		5.3	V
I <sub>IL</sub>	Tri-level input logic low current	V <sub>IN</sub> = 0 V	-80			μA
I <sub>IZ</sub>	Tri-level input Hi-Z current	V <sub>IN</sub> = 1.3 V	-5		5	μA
I <sub>IH</sub>	Tri-level input logic high current	V <sub>IN</sub> = 5.0 V			155	μA
R <sub>PD</sub>	Tri-level pulldown resistance	To GND	18	32	50	kΩ
R <sub>PU</sub>	Tri-level pullup resistance	To DVDD	30	60	90	kΩ
<b>QUAD-LEVEL INPUT (DECAY)</b>						
V <sub>I1</sub>	Quad-level input voltage 1	5% resistor 5 kΩ to GND	0.07	0.11	0.13	V
V <sub>I2</sub>	Quad-level input voltage 2	5% resistor 15 kΩ to GND	0.24	0.32	0.40	V
V <sub>I3</sub>	Quad-level input voltage 3	5% resistor 45 kΩ to GND	0.71	0.97	1.20	V
V <sub>I4</sub>	Quad-level input voltage 4	5% resistor 135 kΩ to GND	2.12	2.90	3.76	V
I <sub>O</sub>	Output current	To GND	14	22	30	μA
<b>CONTROL OUTPUTS (nFAULT)</b>						
V <sub>OL</sub>	Output logic low voltage	I <sub>O</sub> = 1 mA, R <sub>PULLUP</sub> = 4.7 kΩ			0.5	V
I <sub>OH</sub>	Output logic high leakage	V <sub>O</sub> = 5.0 V, R <sub>PULLUP</sub> = 4.7 kΩ	-1		+1	μA

(1) Not tested in production; limits are based on characterization data

## Electrical Characteristics (continued)

over operating free-air temperature range (unless otherwise noted)

PARAMETER		TEST CONDITIONS	MIN	TYP	MAX	UNIT
<b>MOTOR DRIVER OUTPUTS (AOUT1, AOUT2, BOUT1, BOUT2)</b>						
$R_{DS(ON)}$	High-side FET on resistance	$V_M = 24\text{ V}$ , $I = 1\text{ A}$ , $T_A = 25^\circ\text{C}$		440	490	m $\Omega$
$R_{DS(ON)}$	Low-side FET on resistance	$V_M = 24\text{ V}$ , $I = 1\text{ A}$ , $T_A = 25^\circ\text{C}$		420	460	m $\Omega$
$t_{RISE}^{(2)}$	Output rise time			100		ns
$t_{FALL}^{(2)}$	Output fall time			100		ns
$t_{DEAD}^{(2)}$	Output dead time			200		ns
$V_d^{(2)}$	Body diode forward voltage	$I_{OUT} = 0.5\text{ A}$		0.7	1.0	V
<b>PWM CURRENT CONTROL (RREF)</b>						
$A_{RREF}$	RREF transimpedance gain		28.1	30	31.9	k $\Omega$
$V_{RREF}$	RREF voltage	$RREF = 18\text{ to }132\text{ k}\Omega$	1.18	1.232	1.28	V
$t_{OFF}$	PWM off-time			20		$\mu\text{s}$
$C_{RREF}$	Equivalent capacitance on RREF				10	pF
$t_{BLANK}$	PWM blanking time	$I_{RREF} = 1.5\text{ A}$ , 63% to 100% current setting		1.5		$\mu\text{s}$
		$I_{RREF} = 1.5\text{ A}$ , 0% to 63% current setting		1.0		
$\Delta I_{TRIP}$	Current trip accuracy	$I_{RREF} = 1.0\text{ A}$ , 10% to 20% current setting, 1% reference resistor	-25%		25%	
		$I_{RREF} = 1.0\text{ A}$ , 20% to 63% current setting, 1% reference resistor	-12.5%		12.5%	
		$I_{RREF} = 1.0\text{ A}$ , 71% to 100% current setting, 1% reference resistor	-6.25%		6.25%	
<b>PROTECTION CIRCUITS</b>						
$V_{UVLO}$	VM UVLO	VM falling; UVLO report			7.8	V
		VM rising; UVLO recovery			8.0	
$V_{UVLO,HYS}$	Undervoltage hysteresis	Rising to falling threshold		100		mV
$V_{CPUV}$	Charge pump undervoltage	VCP falling; CPUV report		$V_M + 2.0$		V
$I_{OCP}$	Overcurrent protection trip level	Current through any FET	2.3			A
$t_{OCP}$	Overcurrent deglitch time		1.3	1.9	2.8	$\mu\text{s}$
$t_{RETRY}$	Overcurrent retry time		1		1.6	ms
$T_{TSD}^{(2)}$	Thermal shutdown temperature	Die temperature $T_J$	150			$^\circ\text{C}$
$T_{HYS}^{(2)}$	Thermal shutdown hysteresis	Die temperature $T_J$		20		$^\circ\text{C}$

(2) Not tested in production; limits are based on characterization data

### 6.6 Indexer Timing Requirements

T<sub>A</sub> = 25°C, over recommended operating conditions unless otherwise noted

NO.			MIN	MAX	UNIT
1	$f_{STEP}$	Step frequency		500 <sup>(1)</sup>	kHz
2	$t_{WH(STEP)}$	Pulse duration, STEP high	970		ns
3	$t_{WL(STEP)}$	Pulse duration, STEP low	970		ns
4	$t_{SU(DIR, Mx)}$	Setup time, DIR or USMx to STEP rising	200		ns
5	$t_{H(DIR, Mx)}$	Hold time, DIR or USMx to STEP rising	200		ns

(1) STEP input can operate up to 500 kHz, but system bandwidth is limited by the motor load

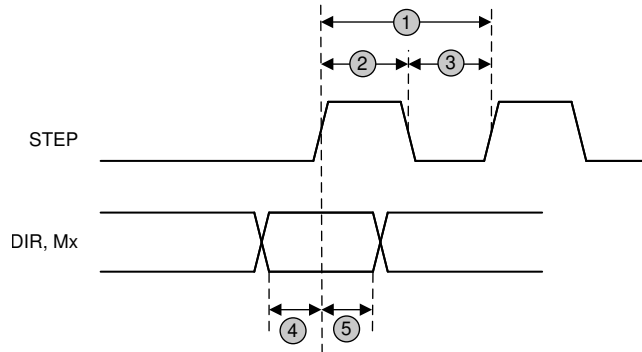

Figure 1. Timing Diagram



## 6.7 Typical Characteristics

Over recommended operating conditions (unless otherwise noted)

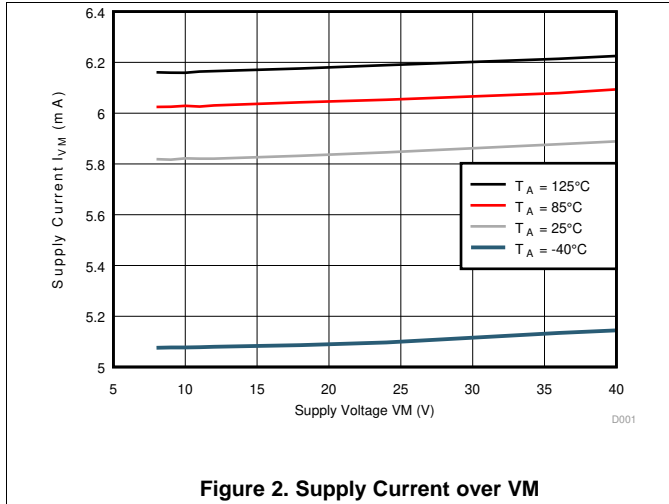

Figure 2. Supply Current over VM

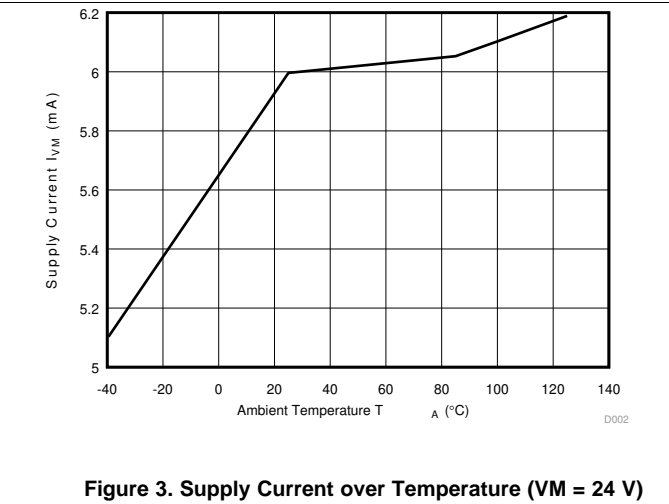

Figure 3. Supply Current over Temperature (VM = 24 V)

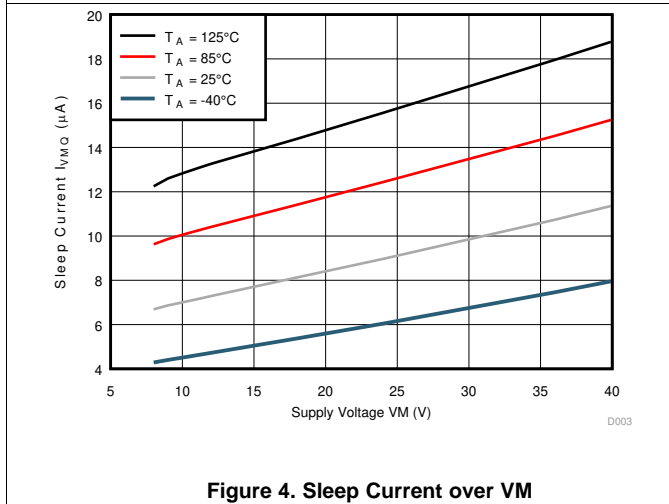

Figure 4. Sleep Current over VM

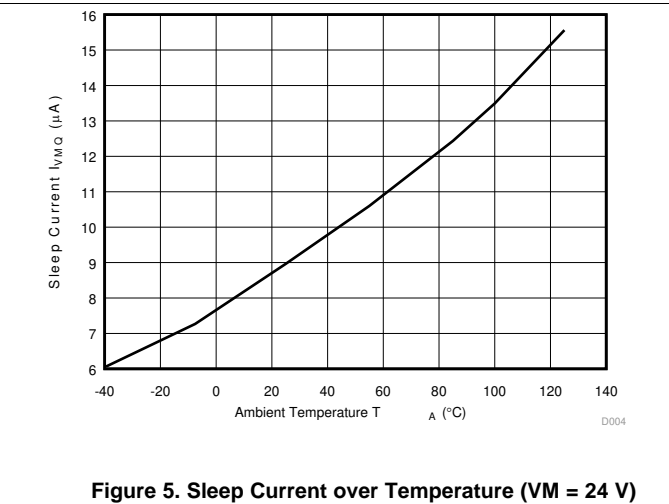

Figure 5. Sleep Current over Temperature (VM = 24 V)

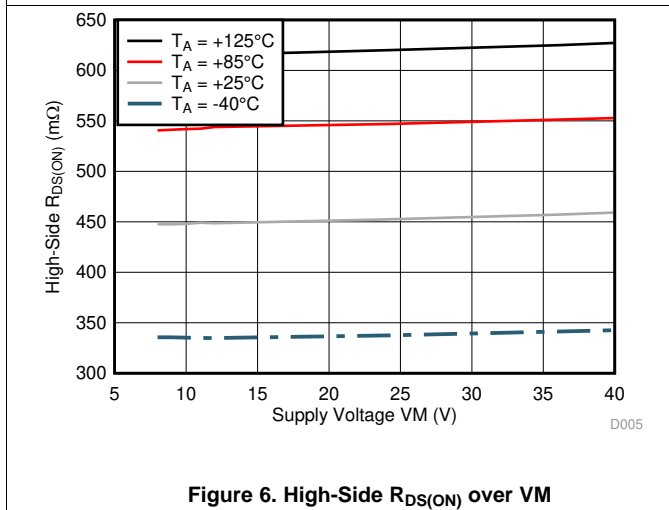

Figure 6. High-Side  $R_{DS(ON)}$  over VM

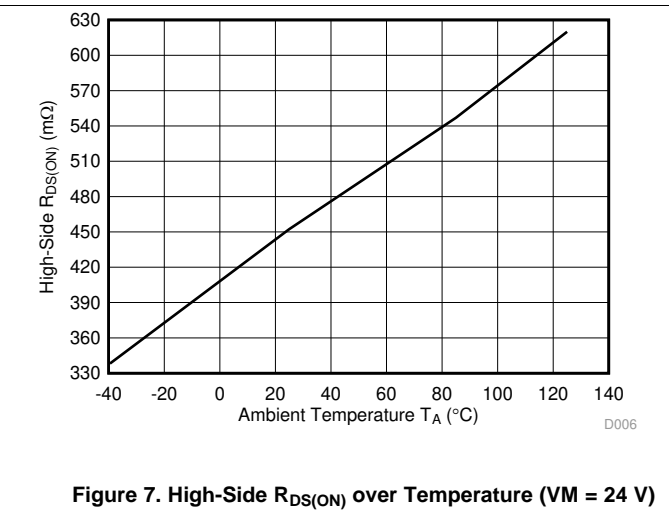

Figure 7. High-Side  $R_{DS(ON)}$  over Temperature (VM = 24 V)

### Typical Characteristics (continued)

Over recommended operating conditions (unless otherwise noted)

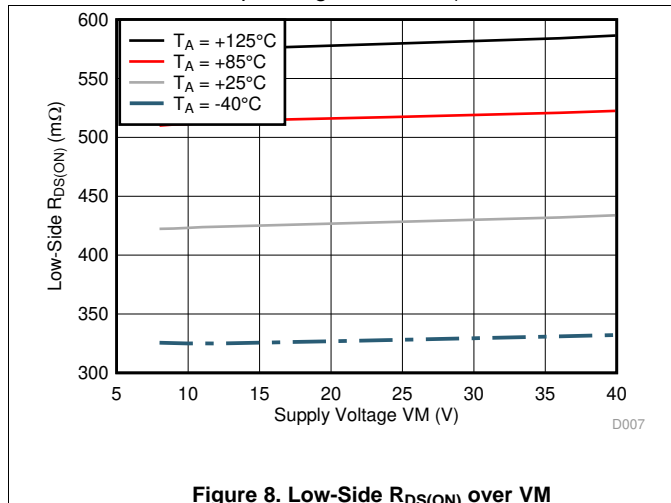

Figure 8. Low-Side  $R_{DS(ON)}$  over VM

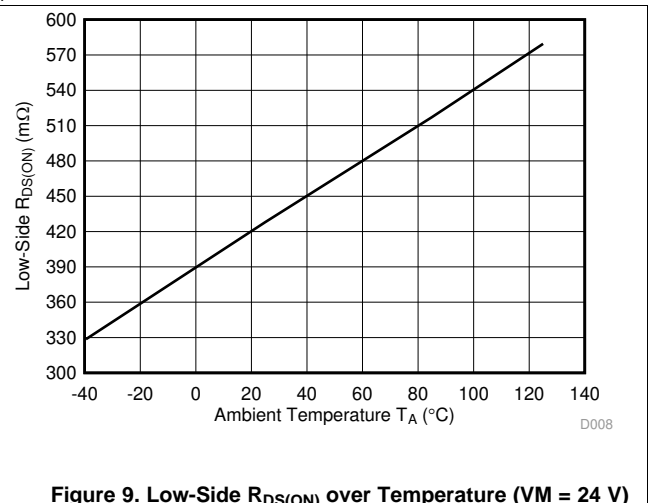

Figure 9. Low-Side  $R_{DS(ON)}$  over Temperature (VM = 24 V)

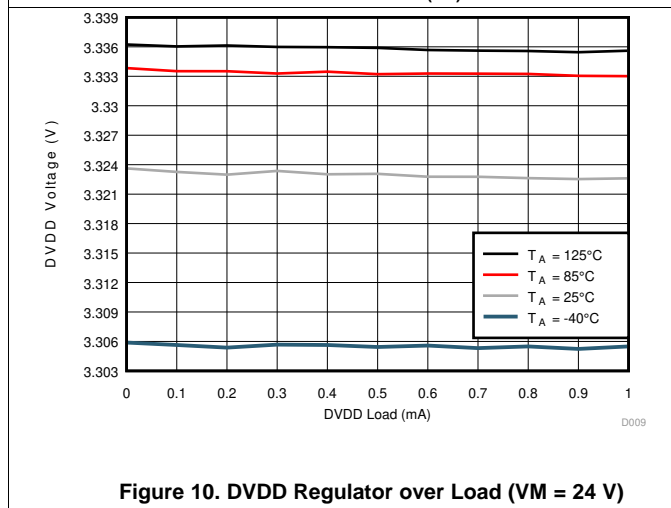

Figure 10. DVDD Regulator over Load (VM = 24 V)

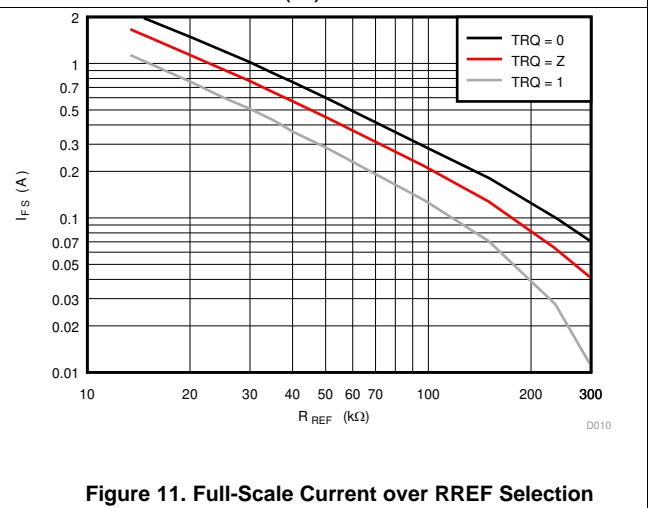

Figure 11. Full-Scale Current over RREF Selection

## 7 Detailed Description

### 7.1 Overview

The DRV8885 is an integrated motor driver solution for bipolar stepper motors. The device integrates two NMOS H-bridges, integrated current sense and regulation circuitry, and a microstepping indexer. The DRV8885 can be powered with a supply voltage between 8 and 37 V, and is capable of providing an output current up to 2.3-A peak, 1.5-A full-scale, or 1.0-A rms. Actual full-scale and rms current will depend on ambient temperature, supply voltage, and PCB ground plane size.

The DRV8885 integrates current sense functionality, which eliminates the need for high-power external sense resistors. This integration does not dissipate the external sense resistor power, because the current sense functionality is not implemented using a resistor-based architecture. This functionality helps improve component cost, board size, PCB layout, and system power consumption.

A simple STEP/DIR interface allows easy interfacing to the controller circuit. The internal indexer is able to execute high-accuracy microstepping without requiring the processor to control the current level. The indexer is capable of full step and half step as well as microstepping to 1/4, 1/8, and 1/16. In addition to the standard half stepping mode, a non-circular 1/2-stepping mode is available for increased torque output at higher motor rpm.

The current regulation is configurable with several decay modes of operation. The decay mode can be selected as a fixed slow, slow/mixed, or mixed decay. The slow/mixed decay mode uses slow decay on increasing steps and mixed decay on decreasing steps.

An adaptive blanking time feature automatically scales the minimum drive time with output current. This helps alleviate zero-crossing distortion by limiting the drive time at low-current steps.

A torque DAC feature allows the controller to scale the output current without needing to scale the reference resistor. The torque DAC is accessed using a digital input pin. This allows the controller to save power by decreasing the current consumption when not high current is not required.

A low-power sleep mode is included which allows the system to save power when not driving the motor.

## 7.2 Functional Block Diagram

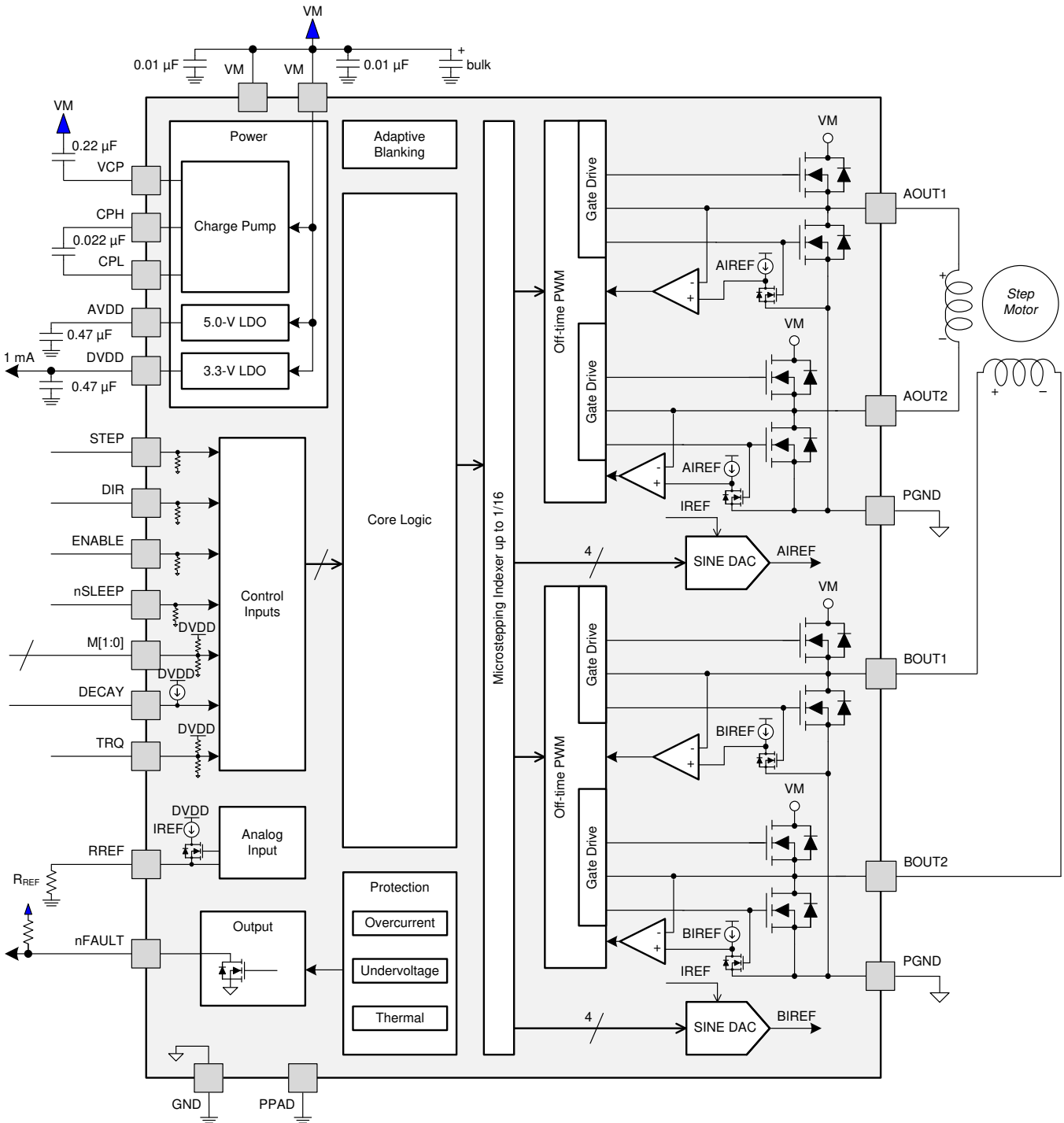

Copyright © 2016, Texas Instruments Incorporated

### 7.3 Feature Description

Table 1 lists the recommended external components for the DRV8885 device.

**Table 1. External Components**

COMPONENT	PIN 1	PIN 2	RECOMMENDED
C <sub>VM</sub>	VM	GND	Two 0.01-μF ceramic capacitors rated for VM
C <sub>VM</sub>	VM	GND	Bulk electrolytic capacitor rated for VM
C <sub>VCP</sub>	VCP	VM	16-V, 0.22-μF ceramic capacitor
C <sub>SW</sub>	CPH	CPL	0.022-μF X7R capacitor rated for VM
C <sub>AVDD</sub>	AVDD	GND	6.3-V, 0.47-μF ceramic capacitor
C <sub>DVDD</sub>	DVDD	GND	6.3-V, 0.47-μF ceramic capacitor
R <sub>nFAULT</sub>	VCC <sup>(1)</sup>	nFAULT	>4.7 kΩ
R <sub>REF</sub>	RREF	GND	Resistor to limit chopping current must be installed. See the <a href="#">Typical Application</a> section for value selection.

(1) VCC is not a pin on the DRV8885, but a VCC supply voltage pullup is required for open-drain output nFAULT; nFAULT may be pulled up to DVDD

#### 7.3.1 Stepper Motor Driver Current Ratings

Stepper motor drivers can be classified using three different numbers to describe the output current: peak, rms, and full-scale.

##### 7.3.1.1 Peak Current Rating

The peak current in a stepper driver is limited by the overcurrent protection trip threshold I<sub>OCP</sub>. The peak current describes any transient duration current pulse, for example when charging capacitance, when the overall duty cycle is very low. In general the minimum value of I<sub>OCP</sub> specifies the peak current rating of the stepper motor driver. For the DRV8885, the peak current rating is 2.3 A per bridge.

##### 7.3.1.2 RMS Current Rating

The rms (average) current is determined by the thermal considerations of the IC. The rms current is calculated based on the R<sub>DS(ON)</sub>, rise and fall time, PWM frequency, device quiescent current, and package thermal performance in a typical system at 25°C. The real operating rms current may be higher or lower depending on heatsinking and ambient temperature. For the DRV8885, the rms current rating is 1.0 A per bridge.

##### 7.3.1.3 Full-Scale Current Rating

The full-scale current describes the top of the sinusoid current waveform while microstepping. Since the sinusoid amplitude is related to the rms current, the full-scale current is also determined by the thermal considerations of the IC. The full-scale current rating is approximately  $\sqrt{2} \times I_{rms}$ . The full-scale current is set by VREF, the sense resistor, and Torque DAC when configuring the DRV8885, see [Current Regulation](#) for details. For the DRV8885, the full-scale current rating is 1.5 A per bridge.

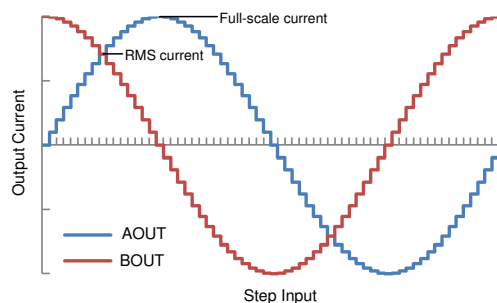

**Figure 12. Full-Scale and rms Current**

### 7.3.2 PWM Motor Drivers

The DRV8885 contains drivers for two full H-bridges. [Figure 13](#) shows a block diagram of the circuitry.

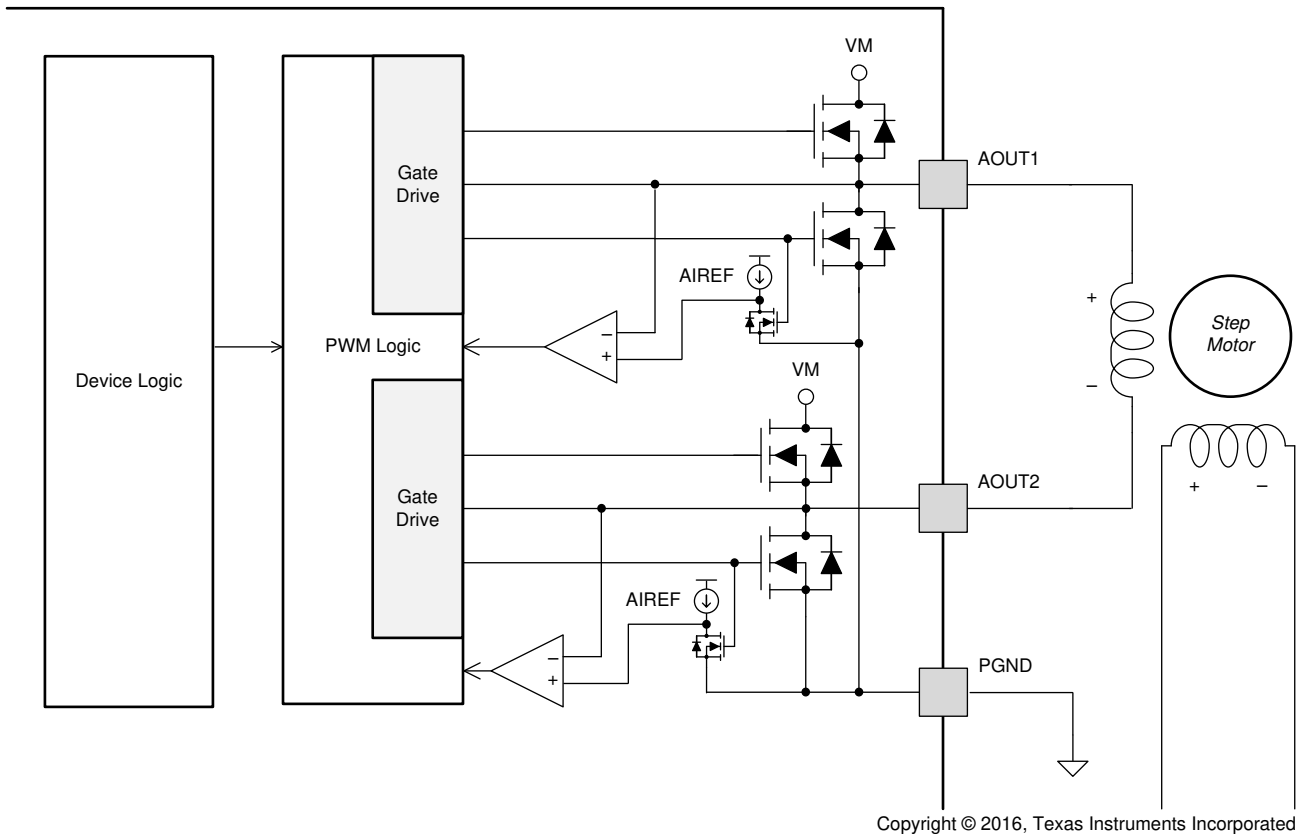

**Figure 13. PWM Motor Driver Block Diagram**

### 7.3.3 Microstepping Indexer

Built-in indexer logic in the DRV8885 allows a number of different stepping configurations. The Mx pins are used to configure the stepping format as shown in [Table 2](#).

**Table 2. Microstepping Settings**

M1	M0	STEP MODE
0	0	Full step (2-phase excitation) with 71% current
0	1	1/16 step
1	0	1/2 step
1	1	1/4 step
0	Z	1/8 step
1	Z	Non-circular 1/2 step

[Table 3](#) shows the relative current and step directions for full-step through 1/16-step operation. The AOUT current is the sine of the electrical angle; BOUT current is the cosine of the electrical angle. Positive current is defined as current flowing from xOUT1 to xOUT2 while driving.

At each rising edge of the STEP input the indexer travels to the next state in the table. The direction is shown with the DIR pin logic high. If the DIR pin is logic low, the sequence is reversed.

On power-up or when exiting sleep mode, keep the STEP pin logic low, otherwise the indexer will advance one step.

Note that if the step mode is changed from full, 1/2, 1/4, 1/8, or 1/16 to full, 1/2, 1/4, 1/8, or 1/16 while stepping, the indexer will advance to the next valid state for the new MODE setting at the rising edge of STEP. If the step mode is changed from or to non-circular 1/2 step the indexer will go immediately to the valid state for that mode.

The home state is an electrical angle of 45°. This state is entered after power-up, after exiting logic undervoltage lockout, or after exiting sleep mode. This is shown in the table below with cells outlined in red.

**Table 3. Microstepping Relative Current Per Step (DIR = 1)**

FULL STEP	1/2 STEP	1/4 STEP	1/8 STEP	1/16 STEP	ELECTRICAL ANGLE (DEGREES)	AOUT CURRENT (% FULL-SCALE)	BOUT CURRENT (% FULL-SCALE)
	1	1	1	1	0.000°	0%	100%
				2	5.625°	10%	100%
			2	3	11.250°	20%	98%
				4	16.875°	29%	96%
		2	3	5	22.500°	38%	92%
				6	28.125°	47%	88%
			4	7	33.750°	56%	83%
				8	39.375°	63%	77%
1	2	3	5	9	45.000°	71%	71%
				10	50.625°	77%	63%
			6	11	56.250°	83%	56%
				12	61.875°	88%	47%
		4	7	13	67.500°	92%	38%
				14	73.125°	96%	29%
			8	15	78.750°	98%	20%
				16	84.375°	100%	10%
	3	5	9	17	90.000°	100%	0%
				18	95.625°	100%	-10%
			10	19	101.250°	98%	-20%
				20	106.875°	96%	-29%
		6	11	21	112.500°	92%	-38%
				22	118.125°	88%	-47%
			12	23	123.750°	83%	-56%
				24	129.375°	77%	-63%
2	4	7	13	25	135.000°	71%	-71%
				26	140.625°	63%	-77%
			14	27	146.250°	56%	-83%
				28	151.875°	47%	-88%
		8	15	29	157.500°	38%	-92%
				30	163.125°	29%	-96%
			16	31	168.750°	20%	-98%
				32	174.375°	10%	-100%
	5	9	17	33	180.000°	0%	-100%
				34	185.625°	-10%	-100%
			18	35	191.250°	-20%	-98%
				36	196.875°	-29%	-96%
		10	19	37	202.500°	-38%	-92%
				38	208.125°	-47%	-88%
			20	39	213.750°	-56%	-83%
				40	219.375°	-63%	-77%

**Table 3. Microstepping Relative Current Per Step (DIR = 1) (continued)**

FULL STEP	1/2 STEP	1/4 STEP	1/8 STEP	1/16 STEP	ELECTRICAL ANGLE (DEGREES)	AOUT CURRENT (% FULL-SCALE)	BOUT CURRENT (% FULL-SCALE)
3	6	11	21	41	225.000°	-71%	-71%
				42	230.625°	-77%	-63%
			22	43	236.250°	-83%	-56%
				44	241.875°	-88%	-47%
		12	23	45	247.500°	-92%	-38%
				46	253.125°	-96%	-29%
			24	47	258.750°	-98%	-20%
				48	264.375°	-100%	-10%
	7	13	25	49	270.000°	-100%	0%
				50	275.625°	-100%	10%
			26	51	281.250°	-98%	20%
				52	286.875°	-96%	29%
		14	27	53	292.500°	-92%	38%
				54	298.125°	-88%	47%
			28	55	303.750°	-83%	56%
				56	309.375°	-77%	63%
4	8	15	29	57	315.000°	-71%	71%
				58	320.625°	-63%	77%
			30	59	326.250°	-56%	83%
				60	331.875°	-47%	88%
		16	31	61	337.500°	-38%	92%
				62	343.125°	-29%	96%
			32	63	348.750°	-20%	98%
				64	354.375°	-10%	100%
	1	1	1	1	360.000°	0%	100%

Non-circular 1/2-step operation is shown below. This stepping mode consumes more power than circular 1/2-step operation, but provides a higher torque at high motor rpm.

**Table 4. Non-Circular 1/2-Stepping Current**

NON-CIRCULAR 1/2 STEP	AOUT CURRENT (% FULL-SCALE)	BOUT CURRENT (% FULL-SCALE)	ELECTRICAL ANGLE (DEGREES)
1	0	100	0
2	100	100	45
3	100	0	90
4	100	-100	135
5	0	-100	180
6	-100	-100	225
7	-100	0	270
8	-100	100	315



### 7.3.4 Current Regulation

The current through the motor windings is regulated by an adjustable fixed-off-time PWM current regulation circuit. When an H-bridge is enabled, current rises through the winding at a rate dependent on the DC voltage, inductance of the winding, and the magnitude of the back EMF present. Once the current hits the current chopping threshold, the bridge enters a decay mode for a fixed, 20 μs, period of time to decrease the current. After the off time expires, the bridge is re-enabled, starting another PWM cycle.

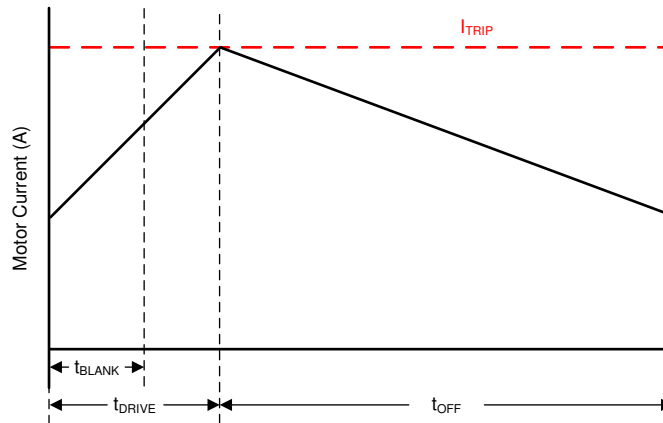

Figure 14. Current Chopping Waveform

The PWM chopping current is set by a comparator which looks at the voltage across current sense FETs in parallel with the low-side drivers. The current sense FETs are biased with a reference current that is the output of a current-mode sine-weighted DAC whose full-scale reference current is set by the current through the RREF pin. An external resistor is placed from the RREF pin to GND in order to set the reference current. In addition, the TRQ pin can further scale the reference current.

The chopping current is calculated as follows:

$$I_{FS} (A) = \frac{A_{RREF} (kA\Omega)}{RREF (k\Omega)} \times TRQ (\%) = \frac{30 (kA\Omega)}{RREF (k\Omega)} \times TRQ (\%) \quad (1)$$

Example: If a 30-kΩ resistor is connected to the RREF pin, the chopping current will be 1 A (TRQ at 100%)

The TRQ pin is the input to a DAC used to scale the output current. The current scalar value for different inputs is shown below.

Table 5. Torque DAC Settings

TRQ	CURRENT SCALAR (TRQ)
0	100%
Z	75%
1	50%

### 7.3.5 Controlling RREF With an MCU

In some cases, the full-scale output current may need to be changed on the fly between many different values, depending on motor speed and loading. The RREF pin reference current can be adjusted in system by tying the RREF resistor to a DAC output instead of GND.

In this mode of operation, as the DAC voltage increases, the reference current will decrease and therefore the full-scale current will decrease as well. For proper operation, the output of the DAC should not rise above  $V_{RREF}$ .

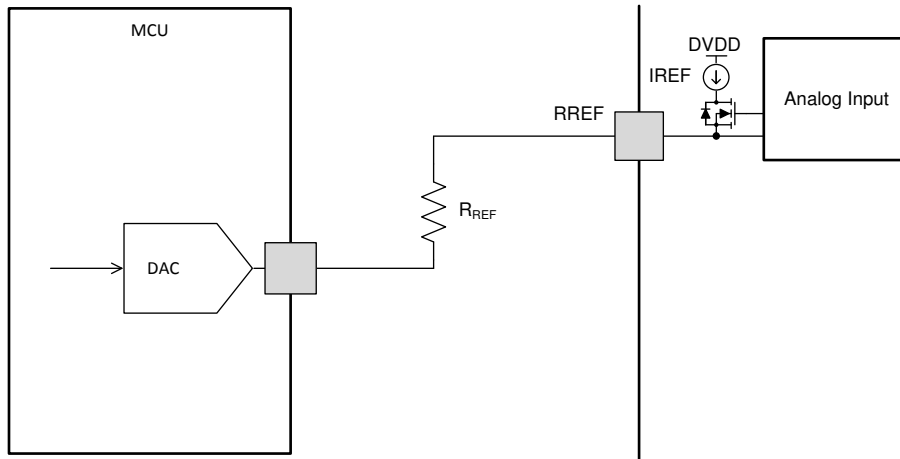

Copyright © 2016, Texas Instruments Incorporated

**Figure 15. Controlling RREF with a DAC**

The chopping current as controlled by a DAC is calculated as follows:

$$I_{FS} (A) = \frac{A_{RREF} (k\Omega) \times [V_{RREF} (V) - V_{DAC} (V)]}{V_{RREF} (V) \times R_{RREF} (k\Omega)} \times TRQ (\%) \tag{2}$$

Example: If a 20-kΩ resistor is connected from the RREF pin to the DAC, and the DAC is outputting 0.74 V, the chopping current will be 600 mA (TRQ at 100%)

RREF can also be adjusted using a PWM signal and low-pass filter.

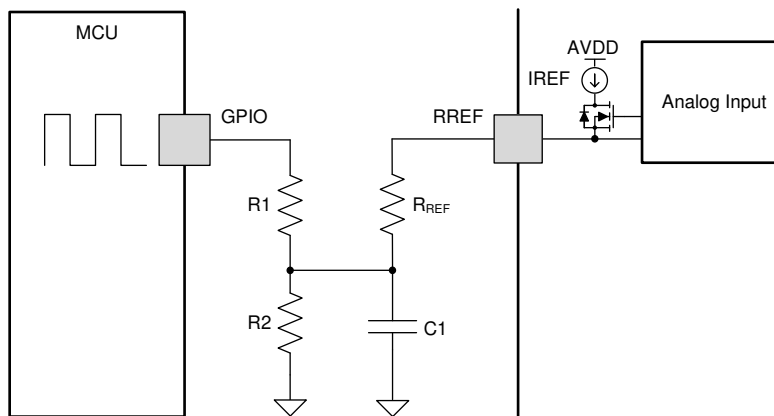

Copyright © 2016, Texas Instruments Incorporated

**Figure 16. Controlling RREF with a PWM Resource**

#### 7.3.5.1 Various Sources of Error

When performing a design error calculation, the different variables that contribute the most to the error must be considered. To do so, first consider the typical values extracted from DRV8885 data sheet which are listed in [Table 6](#) with a 20-kΩ 1% resistor .

**Table 6. DRV8885 Data Sheet Values**

Parameter	Minimum	Typical	Maximum
A <sub>RREF</sub>	28100	30000	31900
V <sub>RREF</sub>	1.18	1.232	1.28
R <sub>REF</sub>	19800	20000	20200

Using and knowing the desired output current, the V<sub>DAC</sub> value can be obtained. For example, the DRV8885EVM, which has a 20-kΩ resistor for R<sub>REF</sub>, was selected to operate at a 1-A, 400mA, and 200 mA current. Table 7 lists the calculated V<sub>DAC</sub> values using typical A<sub>RREF</sub> and V<sub>RREF</sub> data sheet values

**Table 7. V<sub>DAC</sub> Calculation**

Parameter	Minimum	Typical	Maximum
I <sub>FS</sub>	1	0.4	0.2
A <sub>RREF</sub>	30 000	30 000	30 000
V <sub>RREF</sub>	1.232	1.232	1.232
R <sub>REF</sub>	20 000	20 000	20 000
V <sub>DAC</sub>	0.4107	0.9035	1.0677

Next, use Equation 3 and Equation 4 to calculate the worst case value for the minimum and maximum full scale current, respectively.

$$I_{FSmin} (A) = \frac{A_{RREFmin} (k\Omega) \times [V_{RREFmin} (V) - V_{DACmax} (V)]}{V_{RREFmin} (V) \times R_{REFmax} (k\Omega)} \times TRQ (\%) \quad (3)$$

$$I_{FSmax} (A) = \frac{A_{RREFmax} (k\Omega) \times [V_{RREFmax} (V) - V_{DACmin} (V)]}{V_{RREFmax} (V) \times R_{REFmin} (k\Omega)} \times TRQ (\%) \quad (4)$$

These two equations show that error contributions come from V<sub>DAC</sub>, A<sub>RREF</sub>, V<sub>RREF</sub>, and R<sub>REF</sub>. The next sections will show how these different error contributors, affect the overall I<sub>FS</sub> error and how they can be improved.

#### 7.3.5.1.1 V<sub>RREF</sub>, A<sub>RREF</sub>, and R<sub>REF</sub> Error

To observe how V<sub>RREF</sub>, A<sub>RREF</sub>, and R<sub>REF</sub> affect the I<sub>FS</sub> error, Equation 3 and Equation 4 are used with the data sheet values from earlier while V<sub>DAC</sub> voltage remains constant. Table 8, Table 9, and Table 10 list the results at different current levels (1 A, 400 mA, and 200 mA, respectively).

**Table 8. Worst Case Calculation—I<sub>FS</sub> Error at 1 A**

Parameter	Minimum	Typical	Maximum
V <sub>DAC</sub>	0.4107	0.4107	0.4107
A <sub>RREF</sub>	28100	30000	31900
V <sub>RREF</sub>	1.18	1.232	1.28
R <sub>REF</sub>	19800	20000	20200
I <sub>FS</sub> (mA)	906.95	1000	1094.21
Error (%)	-9.30		9.42

**Table 9. Worst Case Calculation—I<sub>FS</sub> Error at 400 mA**

Parameter	Minimum	Typical	Maximum
V <sub>DAC</sub>	0.9035	0.9035	0.9035
A <sub>RREF</sub>	28100	30000	31900
V <sub>RREF</sub>	1.18	1.232	1.28
R <sub>REF</sub>	19800	20000	20200
I <sub>FS</sub> (mA)	326.00	400	473.93
Error (%)	-18.50		18.48

**Table 10. Worst Case Calculation— $I_{FS}$  Error at 200 mA**

Parameter	Minimum	Typical	Maximum
$V_{DAC}$	1.0677	1.0677	1.0677
$A_{RREF}$	28100	30000	31900
$V_{RREF}$	1.18	1.232	1.28
$R_{REF}$	19800	20000	20200
$I_{FS}$ (mA)	135.35	200	267.18
Error (%)	-33.83		33.59

These tables show that as the  $I_{FS}$  current level decreases, the overall error percentage increases due to increasing offset error from the internal signal chain. It is worthy to clarify that the  $V_{RREF}$  and  $A_{RREF}$  values in these tables are data sheet values which represent the characterization data variation across a wide range of temperatures and voltages with additional margin. For information on how to further minimize this percentage of error based on targeted characterization data for  $V_{RREF}$  and  $A_{RREF}$ , see [Application-Specific Error Calculations](#).

### 7.3.5.1.2 $V_{DAC}$ Error

Using the same methodology along with [Equation 3](#) and [Equation 4](#), the  $V_{DAC}$  error contribution to  $I_{FS}$  can be shown. This is done by removing the error from  $V_{RREF}$ ,  $A_{RREF}$ , and  $R_{REF}$ . The following examples show the  $V_{DAC}$  error value with a 3% and 10% variation.

**Table 11. Worst Case Calculation— $V_{DAC}$  3% and 10%,  $I_{FS}$  Error at 1 A**

Parameter	Minimum	Typical	Maximum
<b>3% ERROR</b>			
$V_{DAC}$	0.3983	0.4107	0.423
$A_{RREF}$	30000	30000	30000
$V_{RREF}$	1.232	1.232	1.232
$R_{REF}$	20000	20000	20000
$I_{FS}$ (mA)	985.08	1000	1015.07
Error (%)	-1.50		1.50
<b>10% ERROR</b>			
$V_{DAC}$	0.3696	0.4107	0.4517
$A_{RREF}$	30000	30000	30000
$V_{RREF}$	1.232	1.232	1.232
$R_{REF}$	20000	20000	20000
$I_{FS}$ (mA)	950.08	1000	1050.07
Error (%)	-5.00		5.00

**Table 12. Worst Case Calculation— $V_{DAC}$  3% and 10%,  $I_{FS}$  Error at 400 mA**

Parameter	Minimum	Typical	Maximum
<b>3% ERROR</b>			
$V_{DAC}$	0.8764	0.9035	0.9306
$A_{RREF}$	30000	30000	31 900
$V_{RREF}$	1.232	1.232	1.232
$R_{REF}$	20000	20000	20000
$I_{FS}$ (mA)	367.18	400	433.17
Error (%)	-8.25		8.25
<b>10% ERROR</b>			
$V_{DAC}$	0.8131	0.9035	0.9938
$A_{RREF}$	30000	30000	30000

**Table 12. Worst Case Calculation— $V_{DAC}$  3% and 10%,  
 $I_{FS}$  Error at 400 mA (continued)**

Parameter	Minimum	Typical	Maximum
$V_{RREF}$	1.232	1.232	1.232
$R_{REF}$	20000	20000	20000
$I_{FS}$ (mA)	290.19	400	510.16
Error (%)	-27.48		27.48

**Table 13. Worst Case Calculation— $V_{DAC}$  3% and 10%,  
 $I_{FS}$  Error at 200 mA**

Parameter	Minimum	Typical	Maximum
<b>3% ERROR</b>			
$V_{DAC}$	1.0357	1.0677	1.0998
$A_{RREF}$	30000	30000	30000
$V_{RREF}$	1.232	1.232	1.232
$R_{REF}$	20000	20000	20000
$I_{FS}$ (mA)	161.22	200	239.20
Error (%)	-19.48		19.48
<b>10% ERROR</b>			
$V_{DAC}$	0.9610	1.0677	1.1745
$A_{RREF}$	30000	30000	30000
$V_{RREF}$	1.232	1.232	1.232
$R_{REF}$	20000	20000	20000
$I_{FS}$ (mA)	70.23	200	330.19
Error (%)	-64.92		64.92

These tables show that as the variation in  $V_{DAC}$  increases, the error percentage increases. Also, for very low currents, the error percentage increases greatly because of the  $V_{DAC}$  proximity to the  $V_{RREF}$  voltage.

### 7.3.5.2 Application-Specific Error Calculations

As described in the previous analysis, it is possible to obtain a tighter error calculations by using values for  $V_{RREF}$  and  $A_{RREF}$  for the specific application use case. The data sheet parameters represent limits based on design and characterization data across a wide range of temperatures and voltage with additional margin. For the following example, the operational voltage is limited to  $V_{VM} = 24$  V, a common operating point for the DRV8884, DRV8885, DRV8886, and DRV8886AT.

Considering this use case, [Table 14](#) provides updated values for  $V_{RREF}$  and  $A_{RREF}$ .

**Table 14. Values For DRV8885  $V_{VM} = 24$ -V**

Parameter	Minimum	Typical	Maximum
$A_{RREF}$	28800	30000	31200
$V_{RREF}$	1.207	1.232	1.257
$R_{REF}$	19800	20000	20200

Using values above and maintaining  $V_{DAC}$  constant, the error percentage is reduced as shown in the following tables.

**Table 15.  $I_{FS}$  Error at 1 A,  $V_{DAC}$  Fixed and Application Values**

Parameter	Minimum	Typical	Maximum
$V_{DAC}$	0.4107	0.4107	0.4107
$A_{RREF}$	28800	30000	31200
$V_{RREF}$	1.207	1.232	1.257
$R_{REF}$	19800	20000	20200

**Table 15.  $I_{FS}$  Error at 1 A,  $V_{DAC}$  Fixed and Application Values (continued)**

Parameter	Minimum	Typical	Maximum
$I_{FS}$ (mA)	940.79	1000	1060.8
Error (%)	-5.93		6.07

**Table 16.  $I_{FS}$  Error at 400 mA,  $V_{DAC}$  Fixed and Application Values**

Parameter	Minimum	Typical	Maximum
$V_{DAC}$	0.9035	0.9035	0.9035
$A_{RREF}$	28800	30000	31200
$V_{RREF}$	1.207	1.232	1.257
$R_{REF}$	19800	20000	20200
$I_{FS}$ (mA)	358.54	400	443.18
Error (%)	-10.4		10.75

**Table 17.  $I_{FS}$  Error at 200 mA,  $V_{DAC}$  Fixed and Application Values**

Parameter	Minimum	Typical	Maximum
$V_{DAC}$	1.0677	1.0677	1.0677
$A_{RREF}$	28800	30000	31200
$V_{RREF}$	1.207	1.232	1.257
$R_{REF}$	19800	20000	20200
$I_{FS}$ (mA)	164.51	200	267.26
Error (%)	-17.83		18.51

By keeping  $V_{DAC}$  value fixed or close to be fixed, yields much less error variation. The same calculation can be made using a  $V_{DAC}$  value with a  $\pm 3\%$  variation to compare error percentage difference as shown in the following tables.

**Table 18.  $V_{DAC}$  3%,  $V_{RREF}$  and  $A_{RREF}$  for 24-V Application at 1 A**

Parameter	Minimum	Typical	Maximum
$V_{DAC}$	0.3983	0.4107	0.4230
$A_{RREF}$	28800	30000	31200
$V_{RREF}$	1.207	1.232	1.257
$R_{REF}$	19800	20000	20200
$I_{FS}$ (mA)	926.09	1000	1076.39
Error (%)	-7.4		7.63

**Table 19.  $V_{DAC}$  3%,  $V_{RREF}$  and  $A_{RREF}$  for 24-V Application at 400 mA**

Parameter	Minimum	Typical	Maximum
$V_{DAC}$	0.8764	0.9035	0.9306
$A_{RREF}$	28800	30000	31200
$V_{RREF}$	1.207	1.232	1.257
$R_{REF}$	19800	20000	20200
$I_{FS}$ (mA)	326.52	400	477.16
Error (%)	-18.41		19.24

**Table 20.  $V_{DAC}$  3%,  $V_{RREF}$  and  $A_{RREF}$  for 24-V Application at 200 mA**

Parameter	Minimum	Typical	Maximum
$V_{DAC}$	1.0357	1.0677	1.0998
$A_{RREF}$	28800	30000	31200
$V_{RREF}$	1.207	1.232	1.257
$R_{REF}$	19800	20000	20200
$I_{FS}$ (mA)	126.67	200	277.42
Error (%)	-36.73		38.56

Table 18, Table 19, and Table 20 show values closer to the typical values for both  $V_{DAC}$ ,  $A_{RREF}$ , and  $V_{RREF}$ . From all these calculations, the error percentages for the 200 mA current are higher because at those very low values, the minimum change greatly affects the full current equation. One method to improve the low-value current accuracy is to use a combination of the MCU DAC and TRQ pin. This method can help improve the error by reducing the need to use only the DAC voltage to achieve the low full-scale current. An example of this method is to achieve 200 mA using the 400 mA DAC setting and the 50% TRQ setting.

### 7.3.6 Decay Modes

The DRV8885 decay mode is selected by setting the quad-level DECAY pin to the voltage range in [Table 21](#).

**Table 21. Decay Mode Settings**

DECAY	INCREASING STEPS	DECREASING STEPS
100 mV Can be tied to ground	Slow decay	Mixed decay: 30% fast
300 mV, 15 kΩ to GND	Mixed decay: 30% fast	Mixed decay: 30% fast
1.0 V, 45 kΩ to GND	Mixed decay: 60% fast	Mixed decay: 60% fast
2.9 V Can be tied to DVDD	Slow decay	Slow decay

Increasing and decreasing current are defined in the chart below. For the Slow/Mixed decay mode, the decay mode is set as slow during increasing current steps and mixed decay during decreasing current steps. In full step mode the decreasing steps decay mode is always used.

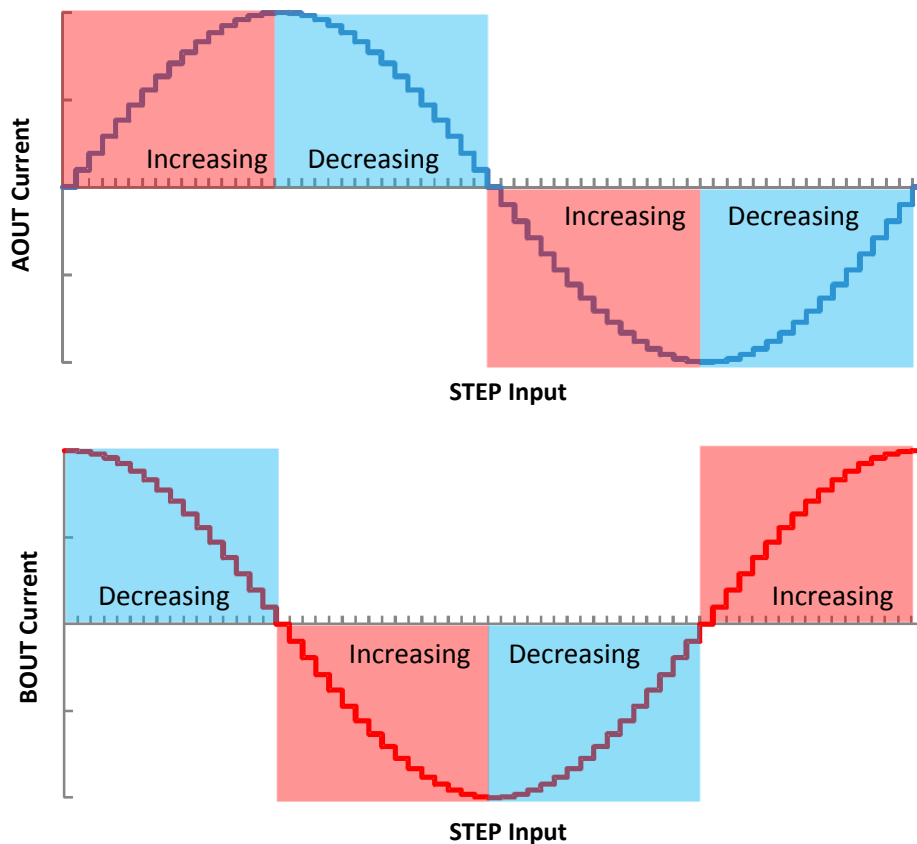

**Figure 17. Definition of Increasing and Decreasing Steps**



7.3.6.1 Mode 1: Slow Decay for Increasing and Decreasing Current

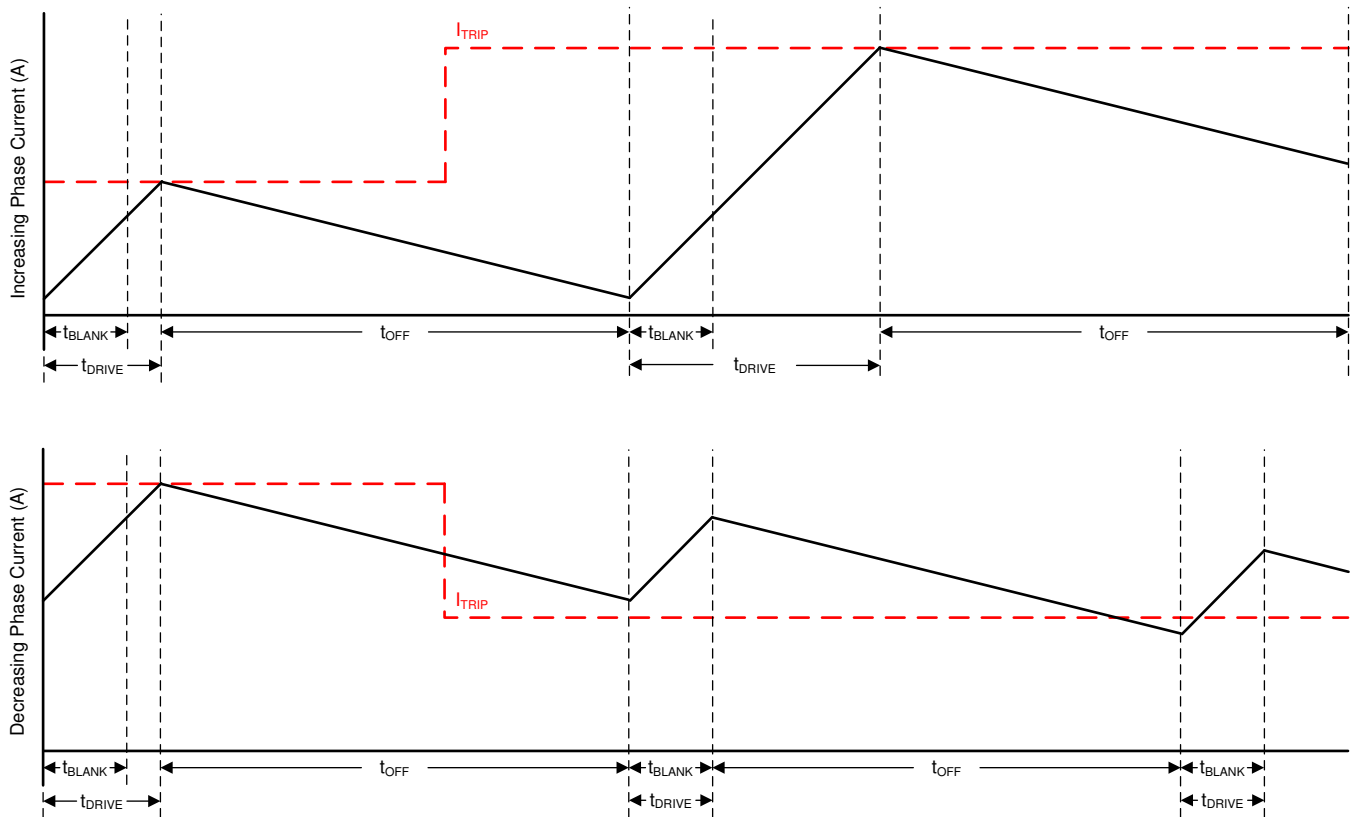
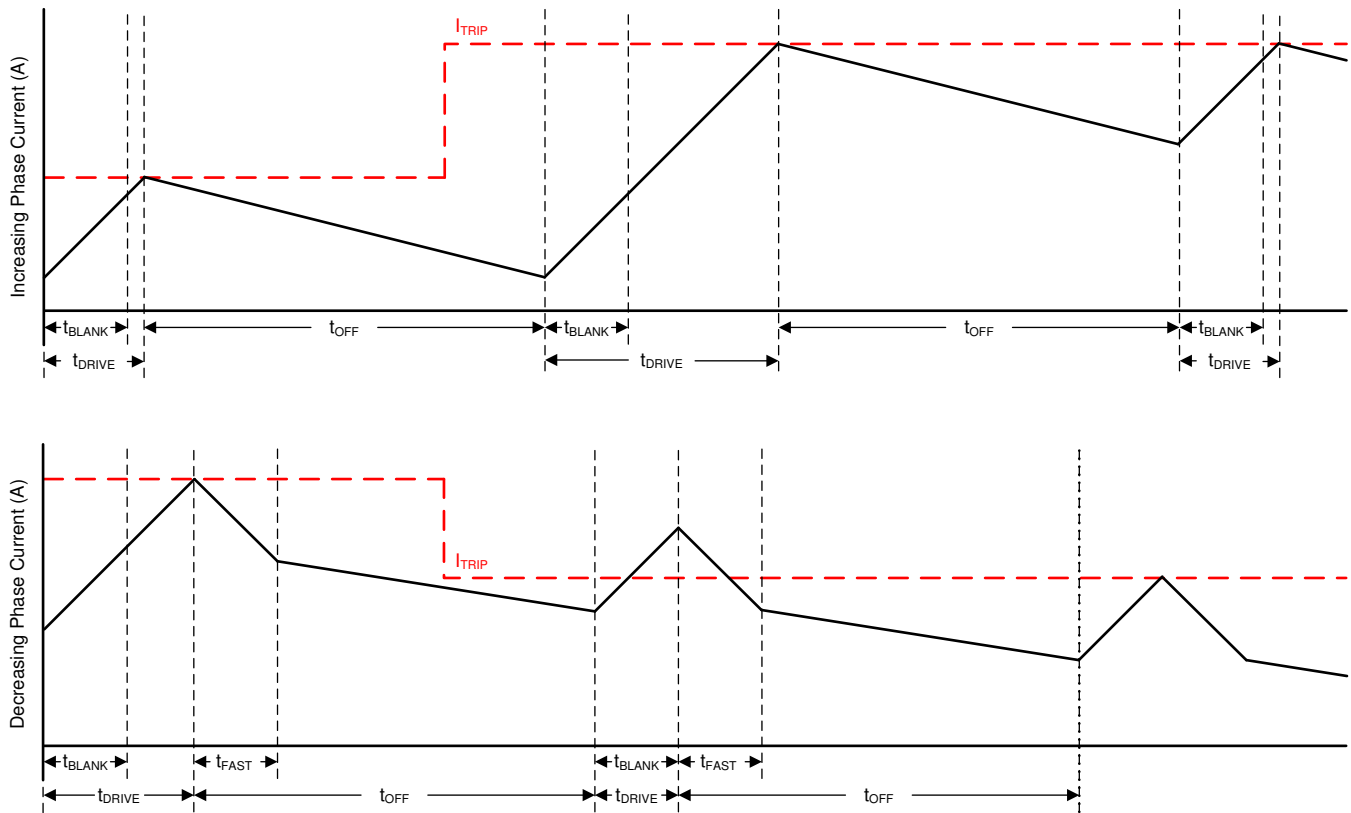

Figure 18. Slow/Slow Decay Mode

During slow decay, both of the low side FETs of the H-bridge are turned on, allowing the current to be recirculated.

Slow decay exhibits the least current ripple of the decay modes for a given  $t_{OFF}$ . However on decreasing current steps, slow decay will take a long time to settle to the new  $I_{TRIP}$  level because the current decreases very slowly.

**7.3.6.2 Mode 2: Slow Decay for Increasing Current, Mixed Decay for Decreasing Current**

**Figure 19. Slow/Mixed Decay Mode**

Mixed decay begins as fast decay for a time, followed by slow decay for the remainder of  $t_{OFF}$ . In this mode, mixed decay only occurs during decreasing current. Slow decay is used for increasing current.

This mode exhibits the same current ripple as slow decay for increasing current, since for increasing current, only slow decay is used. For decreasing current, the ripple is larger than slow decay, but smaller than fast decay. On decreasing current steps, mixed decay will settle to the new  $I_{TRIP}$  level faster than slow decay.

7.3.6.3 Mode 3: Mixed Decay for Increasing and Decreasing Current

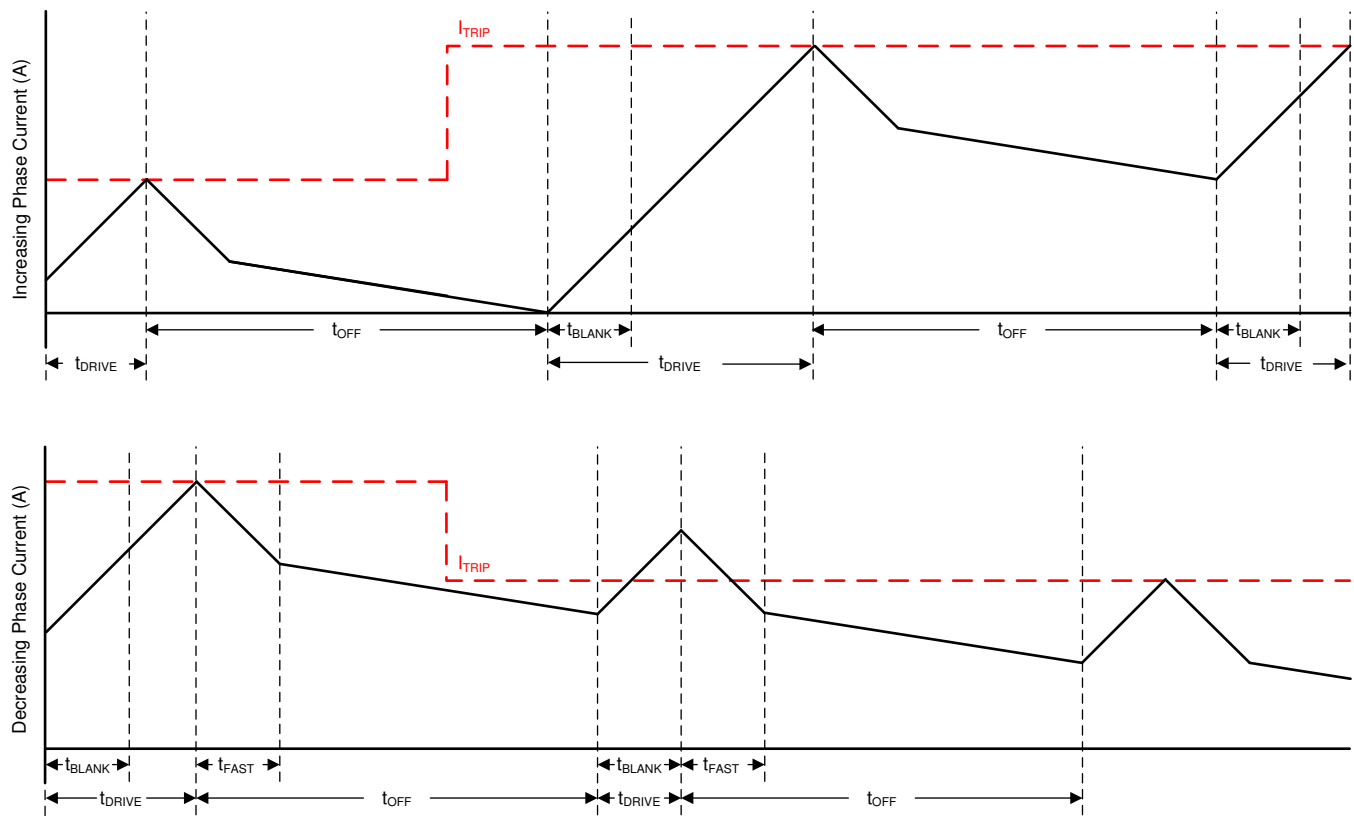

Figure 20. Mixed/Mixed Decay Mode

Mixed decay begins as fast decay for a time, followed by slow decay for the remainder of  $t_{OFF}$ . In this mode, mixed decay occurs for both increasing and decreasing current steps.

This mode exhibits ripple larger than slow decay, but smaller than fast decay. On decreasing current steps, mixed decay will settle to the new  $I_{TRIP}$  level faster than slow decay.

In cases where current is held for a long time (no input in the STEP pin) or at very low stepping speeds, slow decay may not properly regulate current because no back-EMF is present across the motor windings. In this state, motor current can rise very quickly, and requires an excessively large off-time. Increasing/decreasing mixed decay mode allows the current level to stay in regulation when no back-EMF is present across the motor windings.

### 7.3.7 Blanking Time

After the current is enabled in an H-bridge, the current sense comparator is ignored for a period of time ( $t_{BLANK}$ ) before enabling the current sense circuitry. Note that the blanking time also sets the minimum period drive time of the PWM. Table 22 shows the blanking time based on the sine table index and the torque DAC setting. Please note that the torque DAC index is not the same as one step as given in Table 3.

**Table 22. Adaptive Blanking Time over Torque DAC and Microsteps**

$t_{blank} = 1.5 \mu s$        $t_{blank} = 1.0 \mu s$

SINE INDEX	TORQUE DAC (TRQ)		
	100%	75%	50%
16	100%	75%	50%
15	98%	73.5	49%
14	96%	72%	48%
13	92%	69%	46%
12	88%	66%	44%
11	83%	62.3%	41.5%
10	77%	57.8%	38.5%
9	71%	53.3%	35.5%
8	63%	47.3%	31.5%
7	56%	42%	28%
6	47%	35.3	23.5%
5	38%	28.5	19%
4	29%	21.8%	14.5%
3	20%	15%	10%
2	10%	7.5%	5%
1	0%	0%	0%

### 7.3.8 Charge Pump

A charge pump is integrated in order to supply a high-side NMOS gate drive voltage. The charge pump requires a capacitor between the VM and VCP pins. Additionally a low ESR ceramic capacitor is required between pins CPH and CPL.

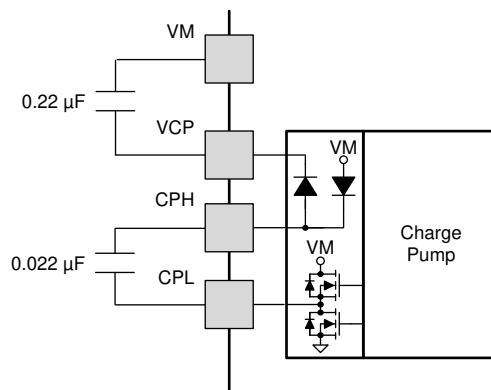

Copyright © 2016, Texas Instruments Incorporated

**Figure 21. Charge Pump Diagram**

### 7.3.9 LDO Voltage Regulator

An LDO regulator is integrated into the DRV8885. DVDD can be used to provide a reference voltage. For proper operation, bypass DVDD to GND using a ceramic capacitor.

The DVDD output is nominally 3.3 V. When the DVDD LDO current load exceeds 1 mA, the output voltage will drop significantly.

The AVDD pin also requires a bypass capacitor to GND. This LDO is for DRV8885 internal use only.

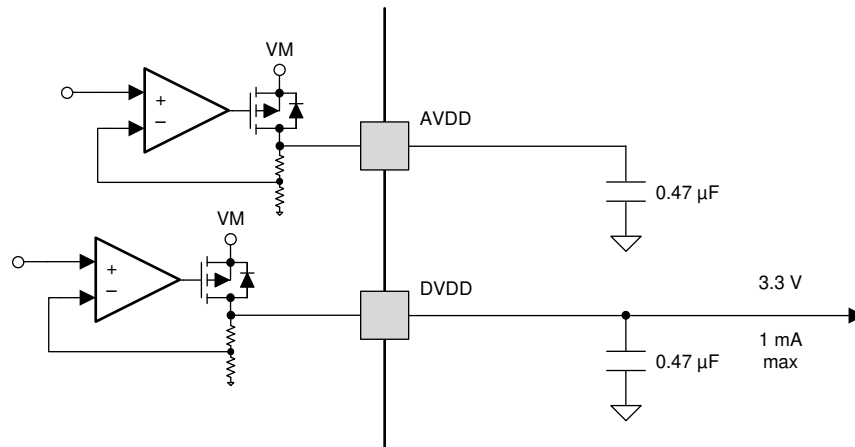

Copyright © 2016, Texas Instruments Incorporated

Figure 22. LDO Diagram

If a digital input needs to be tied permanently high (that is, Mx, DECAY or TRQ), it is preferable to tie the input to DVDD instead of an external regulator. This will save power when VM is not applied or in sleep mode: DVDD is disabled and current will not be flowing through the input pull-down resistors. For reference, logic level inputs have a typical pull-down of 100 kΩ, and tri-level inputs have a typical pull-down of 60 kΩ.

### 7.3.10 Logic and Multi-Level Pin Diagrams

Figure 23 gives the input structure for logic-level pins STEP, DIR, ENABLE, nSLEEP, M1:

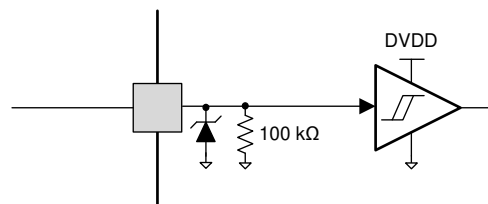

Figure 23. Logic-level Input Pin Diagram

Tri-level logic pins M0 and TRQ have the following structure:

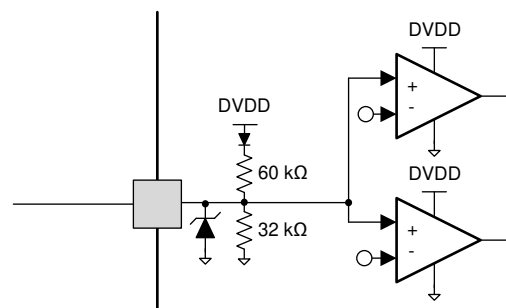
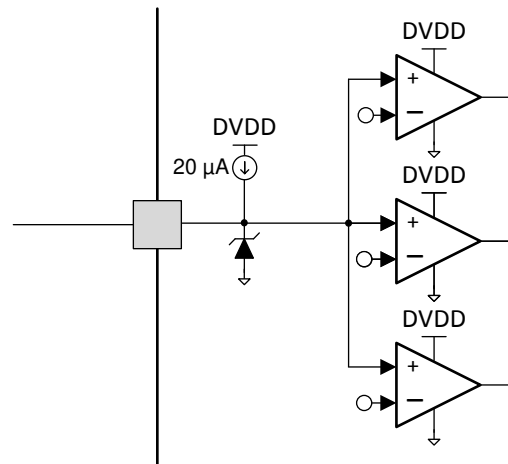

Figure 24. Tri-level Input Pin Diagram

Quad-level logic pin DECAY has the following structure:



**Figure 25. Quad-level Input Pin Diagram**

### 7.3.11 Protection Circuits

The DRV8885 is fully protected against undervoltage, charge pump undervoltage, overcurrent, and overtemperature events.

#### 7.3.11.1 VM Undervoltage Lockout (UVLO)

If at any time the voltage on the VM pin falls below the VM undervoltage lockout threshold voltage ( $V_{UVLO}$ ), all FETs in the H-bridge will be disabled, the charge pump will be disabled, the logic will be reset, the DVDD regulator is disabled, and the nFAULT pin will be driven low. Operation will resume when VM rises above the UVLO threshold. The nFAULT pin will be released after operation has resumed. Decreasing VM below this undervoltage threshold will reset the indexer position.

#### 7.3.11.2 VCP Undervoltage Lockout (CPUV)

If at any time the voltage on the VCP pin falls below the charge pump undervoltage lockout threshold voltage, all FETs in the H-bridge will be disabled and the nFAULT pin will be driven low. Operation will resume when VCP rises above the CPUV threshold. The nFAULT pin will be released after operation has resumed.

#### 7.3.11.3 Overcurrent Protection (OCP)

An analog current limit circuit on each FET limits the current through the FET by removing the gate drive. If this analog current limit persists for longer than  $t_{OCP}$ , all FETs in the H-bridge will be disabled and nFAULT will be driven low.

The driver will be re-enabled after the OCP retry period ( $t_{RETRY}$ ) has passed. nFAULT becomes high again after the retry time. If the fault condition is still present, the cycle repeats. If the fault is no longer present, normal operation resumes and nFAULT remains deasserted.

#### 7.3.11.4 Thermal Shutdown (TSD)

If the die temperature exceeds safe limits, all FETs in the H-bridge will be disabled and the nFAULT pin will be driven low. Once the die temperature has fallen to a safe level operation will automatically resume. The nFAULT pin will be released after operation has resumed.

**Table 23. Fault Condition Summary**

FAULT	CONDITION	ERROR REPORT	H-BRIDGE	CHARGE PUMP	INDEXER	DVDD	RECOVERY
VM undervoltage (UVLO)	$VM < V_{UVLO}$ (max 7.8 V)	nFAULT	Disabled	Disabled	Disabled	Disabled	$VM > V_{UVLO}$ (max 8.0 V)
VCP undervoltage (CPUV)	$VCP < V_{CPUV}$ (typ VM + 2.0 V)	nFAULT	Disabled	Operating	Operating	Operating	$VCP > V_{CPUV}$ (typ VM + 2.7 V)
Overcurrent (OCP)	$I_{OUT} > I_{OCP}$ (min 2.1 A)	nFAULT	Disabled	Operating	Operating	Operating	$t_{RETRY}$
Thermal Shutdown (TSD)	$T_J > T_{TSD}$ (min 150°C)	nFAULT	Disabled	Operating	Operating	Operating	$T_J < T_{TSD} - T_{HYS}$ ( $T_{HYS}$ typ 20°C)

## 7.4 Device Functional Modes

The DRV8885 is active unless the nSLEEP pin is brought logic low. In sleep mode the charge pump is disabled, the H-bridge FETs are disabled Hi-Z, and the V3P3 regulator is disabled. Note that  $t_{SLEEP}$  must elapse after a falling edge on the nSLEEP pin before the device is in sleep mode. The DRV8885 is brought out of sleep mode automatically if nSLEEP is brought logic high. Note that  $t_{WAKE}$  must elapse before the outputs change state after wake-up.

TI recommends to keep the STEP pin logic low when coming out of nSLEEP or when applying power.

If the ENABLE pin is brought logic low, the H-bridge outputs are disabled, but the internal logic will still be active. A rising edge on STEP will advance the indexer, but the outputs will not change state until ENABLE is asserted.

**Table 24. Functional Modes Summary**

CONDITION		H-BRIDGE	CHARGE PUMP	INDEXER	V3P3
Operating	8 V < VM < 40 V nSLEEP pin = 1 ENABLE pin = 1	Operating	Operating	Operating	Operating
Disabled	8 V < VM < 40 V nSLEEP pin = 1 ENABLE pin = 0	Disabled	Operating	Operating	Operating
Sleep mode	8 V < VM < 40 nSLEEP pin = 0	Disabled	Disabled	Disabled	Disabled
Fault encountered	VM undervoltage (UVLO)	Disabled	Disabled	Disabled	Disabled
	VCP undervoltage (CPUV)	Disabled	Operating	Operating	Operating
	Overcurrent (OCP)	Disabled	Operating	Operating	Operating
	Thermal Shutdown (TSD)	Disabled	Operating	Operating	Operating

## 8 Application and Implementation

### NOTE

Information in the following applications sections is not part of the TI component specification, and TI does not warrant its accuracy or completeness. TI's customers are responsible for determining suitability of components for their purposes. Customers should validate and test their design implementation to confirm system functionality.

### 8.1 Application Information

The DRV8885 is used in bipolar stepper control.

### 8.2 Typical Application

The following design procedure can be used to configure the DRV8885.

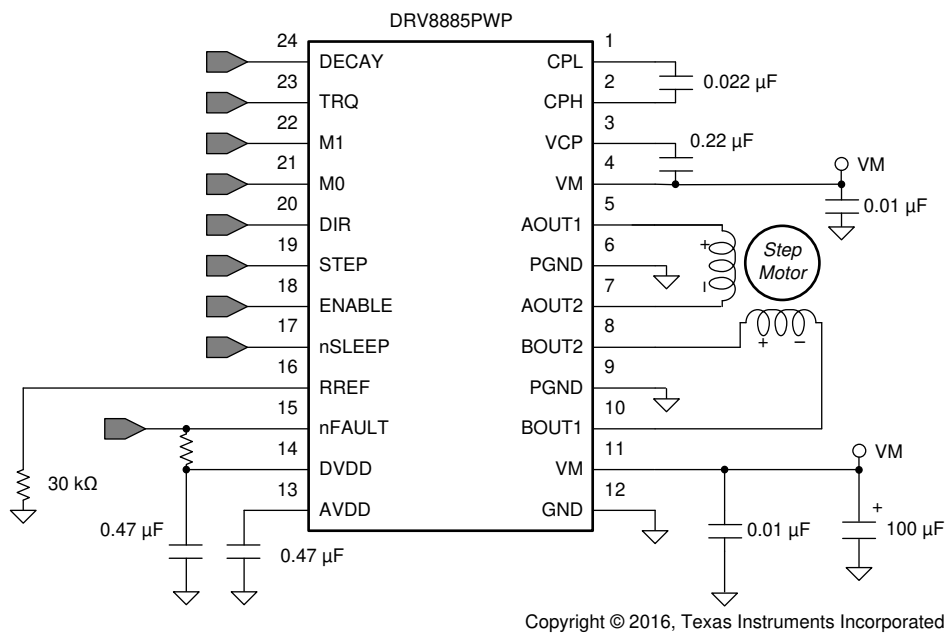

Copyright © 2016, Texas Instruments Incorporated

Figure 26. Typical Application Schematic

#### 8.2.1 Design Requirements

Table 25 gives design input parameters for system design.

Table 25. Design Parameters

DESIGN PARAMETER	REFERENCE	EXAMPLE VALUE
Supply voltage	VM	24 V
Motor winding resistance	$R_L$	2.6 $\Omega$ /phase
Motor winding inductance	$L_L$	1.4 mH/phase
Motor full step angle	$\theta_{step}$	1.8°/step
Target microstepping level	$n_m$	1/8 step
Target motor speed	v	120 rpm
Target full-scale current	$I_{FS}$	1.0 A



## 8.2.2 Detailed Design Procedure

### 8.2.2.1 Stepper Motor Speed

The first step in configuring the DRV8885 requires the desired motor speed and microstepping level. If the target application requires a constant speed, then a square wave with frequency  $f_{\text{step}}$  must be applied to the STEP pin.

If the target motor speed is too high, the motor will not spin. Make sure that the motor can support the target speed.

For a desired motor speed ( $v$ ), microstepping level ( $n_m$ ), and motor full step angle ( $\theta_{\text{step}}$ ),

$$f_{\text{step}} \text{ (steps / s)} = \frac{v \text{ (rpm)} \times 360 \text{ (}^\circ \text{ / rot)}}{\theta_{\text{step}} \text{ (}^\circ \text{ / step)} \times n_m \text{ (steps / microstep)} \times 60 \text{ (s / min)}} \quad (5)$$

$\theta_{\text{step}}$  can be found in the stepper motor data sheet, or written on the motor itself.

For the DRV8885, the microstepping level is set by the Mx pins and can be any of the settings in the table below. Higher microstepping will mean a smoother motor motion and less audible noise, but will increase switching losses and require a higher  $f_{\text{step}}$  to achieve the same motor speed.

**Table 26. Microstepping Indexer Settings**

M1	M0	STEP MODE
0	0	Full step (2-phase excitation) with 71% current
0	1	1/16 step
1	0	1/2 step
1	1	1/4 step
0	Z	1/8 step
1	Z	Non-circular 1/2 step

**Example:** Target 120 rpm at 1/8 microstep mode. The motor is 1.8°/step

$$f_{\text{step}} \text{ (steps / s)} = \frac{120 \text{ rpm} \times 360^\circ \text{ / rot}}{1.8^\circ \text{ / step} \times 1/8 \text{ steps / microstep} \times 60 \text{ s / min}} = 3.2 \text{ kHz} \quad (6)$$

### 8.2.2.2 Current Regulation

In a stepper motor, the full-scale current ( $I_{\text{FS}}$ ) is the maximum current driven through either winding. This quantity will depend on the RREF resistor and the TRQ setting. During stepping,  $I_{\text{FS}}$  defines the current chopping threshold ( $I_{\text{TRIP}}$ ) for the maximum current step.

$$I_{\text{FS}} \text{ (A)} = \frac{A_{\text{RREF}} \text{ (k}\Omega\text{)}}{R_{\text{REF}} \text{ (k}\Omega\text{)}} = \frac{30 \text{ (k}\Omega\text{)} \times \text{TRQ}\%}{R_{\text{REF}} \text{ (k}\Omega\text{)}} \quad (7)$$

Note that  $I_{\text{FS}}$  must also follow [Equation 8](#) in order to avoid saturating the motor. VM is the motor supply voltage, and  $R_L$  is the motor winding resistance.

$$I_{\text{FS}} \text{ (A)} < \frac{VM \text{ (V)}}{R_L \text{ (}\Omega\text{)} + 2 \times R_{\text{DS(ON)}} \text{ (}\Omega\text{)}} \quad (8)$$

### 8.2.2.3 Decay Modes

The DRV8885 supports three different decay modes: slow decay, slow/mixed and all mixed decay. The current through the motor windings is regulated using an adjustable fixed-time-off scheme. This means that after any drive phase, when a motor winding current has hit the current chopping threshold ( $I_{\text{TRIP}}$ ), the DRV8885 will place the winding in one of the three decay modes for  $t_{\text{OFF}}$ . After  $t_{\text{OFF}}$ , a new drive phase starts.

The blanking time  $t_{\text{BLANK}}$  defines the minimum drive time for the PWM current chopping.  $I_{\text{TRIP}}$  is ignored during  $t_{\text{BLANK}}$ , so the winding current may overshoot the trip level.

### 8.2.3 Application Curves

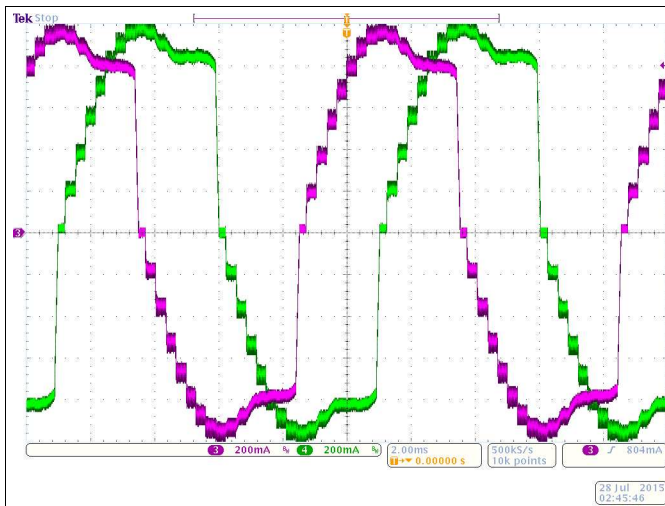

Figure 27. Microstepping Using Slow Decay on Increasing and Decreasing Steps; Current Loses Regulation on Falling Steps

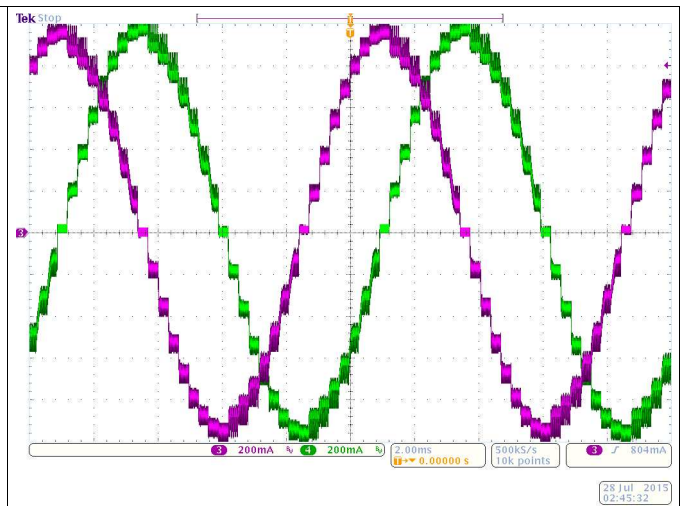

Figure 28. Microstepping Using Slow Decay on Increasing Steps and Mixed 30% Fast Decay on Decreasing Steps

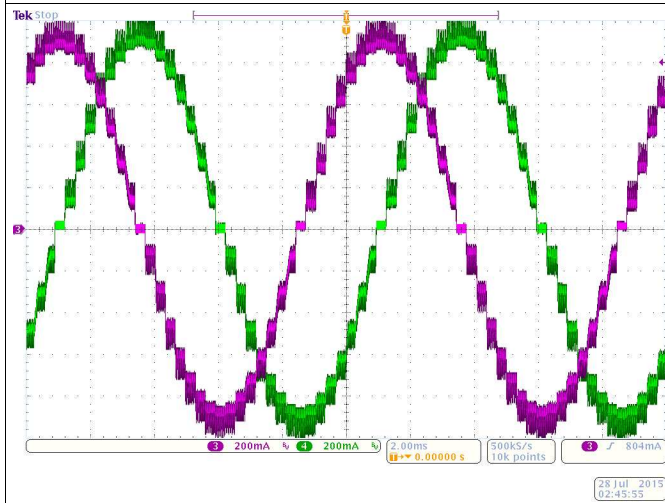

Figure 29. Microstepping Using Mixed 30% Fast Decay on Increasing and Decreasing Steps

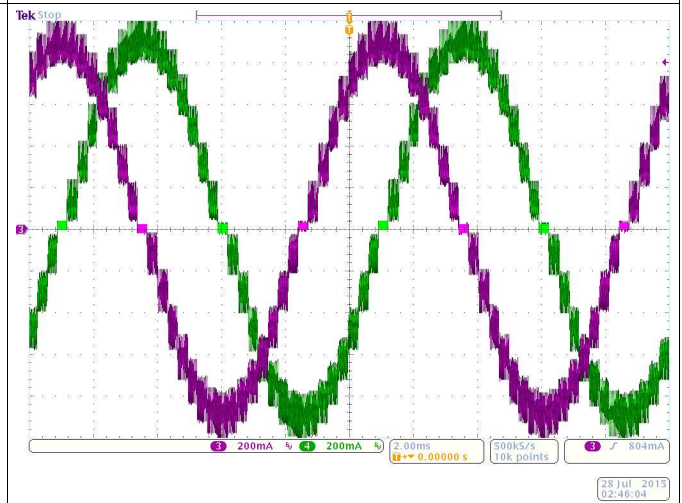

Figure 30. Microstepping Using Mixed 60% Fast Decay on Increasing and Decreasing Steps

## 9 Power Supply Recommendations

The DRV8885 is designed to operate from an input voltage supply (VM) range between 8 V and 35 V. A 0.01  $\mu\text{F}$  ceramic capacitor rated for VM must be placed at each VM pin as close to the DRV8885 as possible. In addition, a bulk capacitor must be included on VM.

### 9.1 Bulk Capacitance

Having appropriate local bulk capacitance is an important factor in motor drive system design. It is generally beneficial to have more bulk capacitance, while the disadvantages are increased cost and physical size.

The amount of local capacitance needed depends on a variety of factors, including:

- The highest current required by the motor system
- The power supply's capacitance and ability to source current
- The amount of parasitic inductance between the power supply and motor system
- The acceptable voltage ripple
- The type of motor used (brushed DC, brushless DC, stepper)
- The motor braking method

The inductance between the power supply and motor drive system will limit the rate current can change from the power supply. If the local bulk capacitance is too small, the system will respond to excessive current demands or dumps from the motor with a change in voltage. When adequate bulk capacitance is used, the motor voltage remains stable and high current can be quickly supplied.

The data sheet generally provides a recommended value, but system-level testing is required to determine the appropriate sized bulk capacitor.

The voltage rating for bulk capacitors should be higher than the operating voltage, to provide margin for cases when the motor transfers energy to the supply.

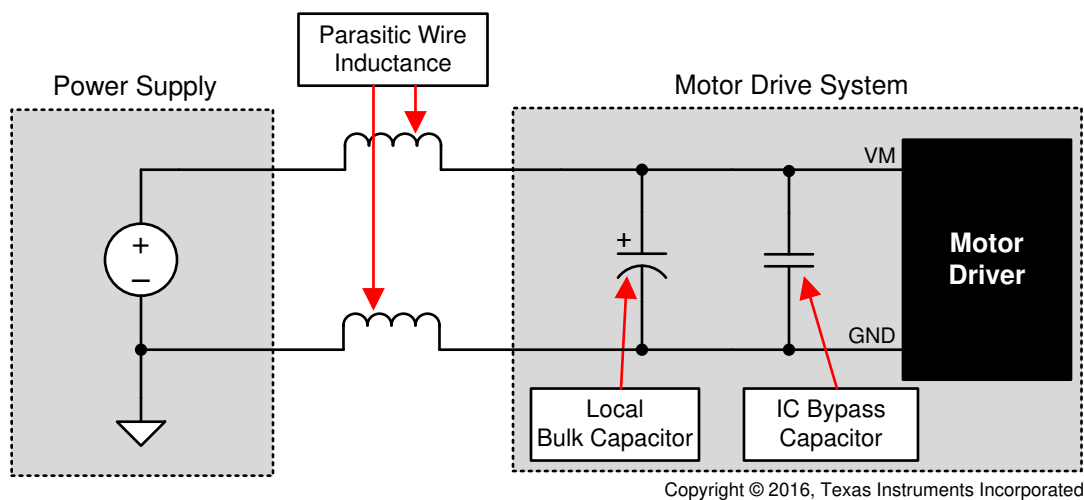

Figure 31. Example Setup of Motor Drive System With External Power Supply

## 10 Layout

### 10.1 Layout Guidelines

The VM terminal should be bypassed to GND using a low-ESR ceramic bypass capacitor with a recommended value of 0.01  $\mu\text{F}$  rated for VM. This capacitor should be placed as close to the VM pin as possible with a thick trace or ground plane connection to the device GND pin.

The VM pin must be bypassed to ground using a bulk capacitor rated for VM. This component may be an electrolytic.

A low-ESR ceramic capacitor must be placed in between the CPL and CPH pins. A value of 0.022  $\mu\text{F}$  rated for VM is recommended. Place this component as close to the pins as possible.

A low-ESR ceramic capacitor must be placed in between the VM and VCP pins. A value of 0.22  $\mu\text{F}$  rated for 16 V is recommended. Place this component as close to the pins as possible.

Bypass AVDD and DVDD to ground with a ceramic capacitor rated 6.3 V. Place this bypassing capacitor as close to the pin as possible.

### 10.2 Layout Example

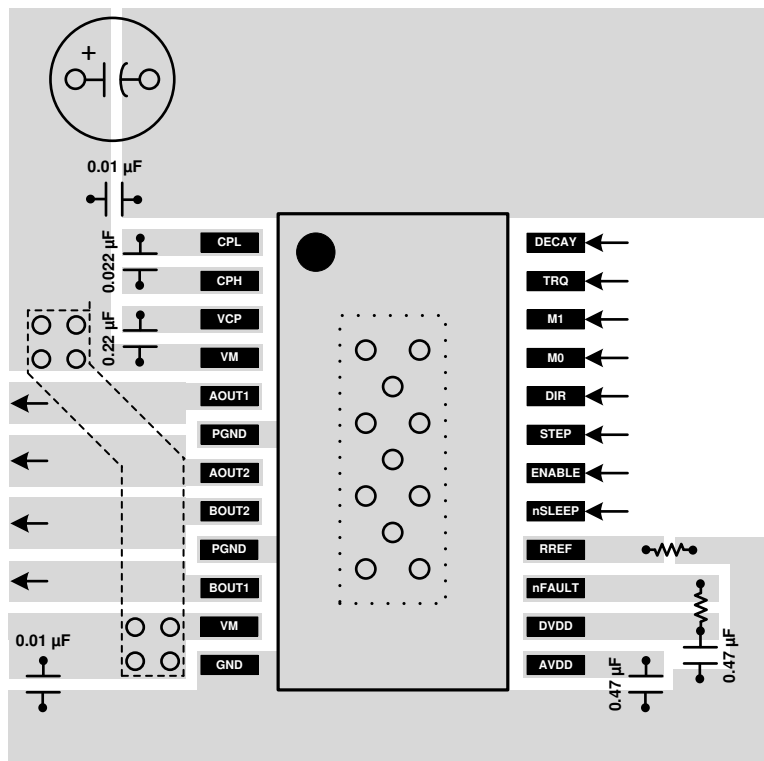

Figure 32. Layout Recommendation

## 11 Device and Documentation Support

### 11.1 Documentation Support

#### 11.1.1 Related Documentation

For related documentation, see the following:

- Texas Instruments, [Calculating Motor Driver Power Dissipation](#) application report
- Texas Instruments, [Current Recirculation and Decay Modes](#) application report
- Texas Instruments, [Full-Scale Current Adjustment Using a Digital-to-Analog Converter \(DAC\)](#) application report
- Texas Instruments, [DRV8885 Evaluation Module \(EVM\) User's Guide](#)
- Texas Instruments, [PowerPAD™ Made Easy](#) application report
- Texas Instruments, [PowerPAD™ Thermally Enhanced Package](#) application report
- Texas Instruments, [Understanding Motor Driver Current Ratings](#) application report

#### 11.2 Receiving Notification of Documentation Updates

To receive notification of documentation updates, navigate to the device product folder on ti.com. In the upper right corner, click on *Alert me* to register and receive a weekly digest of any product information that has changed. For change details, review the revision history included in any revised document.

#### 11.3 Community Resources

[TI E2E™ support forums](#) are an engineer's go-to source for fast, verified answers and design help — straight from the experts. Search existing answers or ask your own question to get the quick design help you need.

Linked content is provided "AS IS" by the respective contributors. They do not constitute TI specifications and do not necessarily reflect TI's views; see TI's [Terms of Use](#).

#### 11.4 Trademarks

PowerPAD, E2E are trademarks of Texas Instruments.  
All other trademarks are the property of their respective owners.

#### 11.5 Electrostatic Discharge Caution



These devices have limited built-in ESD protection. The leads should be shorted together or the device placed in conductive foam during storage or handling to prevent electrostatic damage to the MOS gates.

#### 11.6 Glossary

[SLYZ022](#) — *TI Glossary*.

This glossary lists and explains terms, acronyms, and definitions.

## 12 Mechanical, Packaging, and Orderable Information

The following pages include mechanical, packaging, and orderable information. This information is the most current data available for the designated devices. This data is subject to change without notice and revision of this document. For browser-based versions of this data sheet, refer to the left-hand navigation.

**PACKAGING INFORMATION**

Orderable Device	Status (1)	Package Type	Package Drawing	Pins	Package Qty	Eco Plan (2)	Lead finish/ Ball material (6)	MSL Peak Temp (3)	Op Temp (°C)	Device Marking (4/5)	Samples
DRV8885PWP	ACTIVE	HTSSOP	PWP	24	60	RoHS & Green	NIPDAU	Level-3-260C-168 HR	-40 to 125	DRV8885	<a href="#">Samples</a>
DRV8885PWPR	ACTIVE	HTSSOP	PWP	24	2000	RoHS & Green	NIPDAU	Level-3-260C-168 HR	-40 to 125	DRV8885	<a href="#">Samples</a>
DRV8885RHRR	ACTIVE	WQFN	RHR	28	3000	RoHS & Green	NIPDAU	Level-1-260C-UNLIM	-40 to 125	DRV8885	<a href="#">Samples</a>
DRV8885RHRT	ACTIVE	WQFN	RHR	28	250	RoHS & Green	NIPDAU	Level-1-260C-UNLIM	-40 to 125	DRV8885	<a href="#">Samples</a>

(1) The marketing status values are defined as follows:

**ACTIVE:** Product device recommended for new designs.

**LIFEBUY:** TI has announced that the device will be discontinued, and a lifetime-buy period is in effect.

**NRND:** Not recommended for new designs. Device is in production to support existing customers, but TI does not recommend using this part in a new design.

**PREVIEW:** Device has been announced but is not in production. Samples may or may not be available.

**OBSOLETE:** TI has discontinued the production of the device.

(2) **RoHS:** TI defines "RoHS" to mean semiconductor products that are compliant with the current EU RoHS requirements for all 10 RoHS substances, including the requirement that RoHS substance do not exceed 0.1% by weight in homogeneous materials. Where designed to be soldered at high temperatures, "RoHS" products are suitable for use in specified lead-free processes. TI may reference these types of products as "Pb-Free".

**RoHS Exempt:** TI defines "RoHS Exempt" to mean products that contain lead but are compliant with EU RoHS pursuant to a specific EU RoHS exemption.

**Green:** TI defines "Green" to mean the content of Chlorine (Cl) and Bromine (Br) based flame retardants meet JS709B low halogen requirements of <=1000ppm threshold. Antimony trioxide based flame retardants must also meet the <=1000ppm threshold requirement.

(3) MSL, Peak Temp. - The Moisture Sensitivity Level rating according to the JEDEC industry standard classifications, and peak solder temperature.

(4) There may be additional marking, which relates to the logo, the lot trace code information, or the environmental category on the device.

(5) Multiple Device Markings will be inside parentheses. Only one Device Marking contained in parentheses and separated by a "-" will appear on a device. If a line is indented then it is a continuation of the previous line and the two combined represent the entire Device Marking for that device.

(6) Lead finish/Ball material - Orderable Devices may have multiple material finish options. Finish options are separated by a vertical ruled line. Lead finish/Ball material values may wrap to two lines if the finish value exceeds the maximum column width.

**Important Information and Disclaimer:**The information provided on this page represents TI's knowledge and belief as of the date that it is provided. TI bases its knowledge and belief on information provided by third parties, and makes no representation or warranty as to the accuracy of such information. Efforts are underway to better integrate information from third parties. TI has taken and

continues to take reasonable steps to provide representative and accurate information but may not have conducted destructive testing or chemical analysis on incoming materials and chemicals. TI and TI suppliers consider certain information to be proprietary, and thus CAS numbers and other limited information may not be available for release.

In no event shall TI's liability arising out of such information exceed the total purchase price of the TI part(s) at issue in this document sold by TI to Customer on an annual basis.

**TAPE AND REEL INFORMATION**

**QUADRANT ASSIGNMENTS FOR PIN 1 ORIENTATION IN TAPE**

\*All dimensions are nominal

Device	Package Type	Package Drawing	Pins	SPQ	Reel Diameter (mm)	Reel Width W1 (mm)	A0 (mm)	B0 (mm)	K0 (mm)	P1 (mm)	W (mm)	Pin1 Quadrant
DRV8885PWPR	HTSSOP	PWP	24	2000	330.0	16.4	6.95	8.3	1.6	8.0	16.0	Q1
DRV8885RHRR	WQFN	RHR	28	3000	330.0	12.4	3.8	5.8	1.2	8.0	12.0	Q1
DRV8885RHRT	WQFN	RHR	28	250	180.0	12.4	3.8	5.8	1.2	8.0	12.0	Q1



**TAPE AND REEL BOX DIMENSIONS**

\*All dimensions are nominal

Device	Package Type	Package Drawing	Pins	SPQ	Length (mm)	Width (mm)	Height (mm)
DRV8885PWPR	HTSSOP	PWP	24	2000	350.0	350.0	43.0
DRV8885RHRR	WQFN	RHR	28	3000	367.0	367.0	35.0
DRV8885RHRT	WQFN	RHR	28	250	210.0	185.0	35.0

**TUBE**

\*All dimensions are nominal

Device	Package Name	Package Type	Pins	SPQ	L (mm)	W (mm)	T (μm)	B (mm)
DRV8885PWP	PWP	HTSSOP	24	60	530	10.2	3600	3.5

## GENERIC PACKAGE VIEW

**PWP 24**

**PowerPAD™ TSSOP - 1.2 mm max height**

4.4 x 7.6, 0.65 mm pitch

PLASTIC SMALL OUTLINE

This image is a representation of the package family, actual package may vary.  
Refer to the product data sheet for package details.

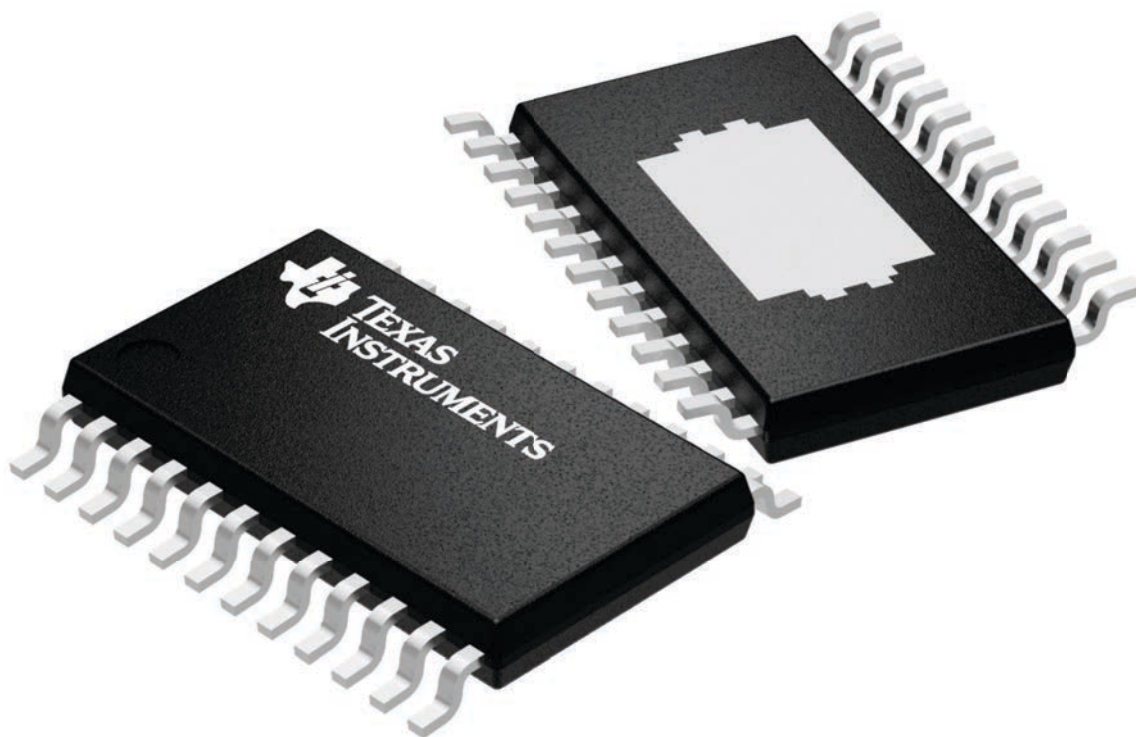

4224742/B



# PACKAGE OUTLINE

## PWP0024B

## PowerPAD™ TSSOP - 1.2 mm max height

PLASTIC SMALL OUTLINE

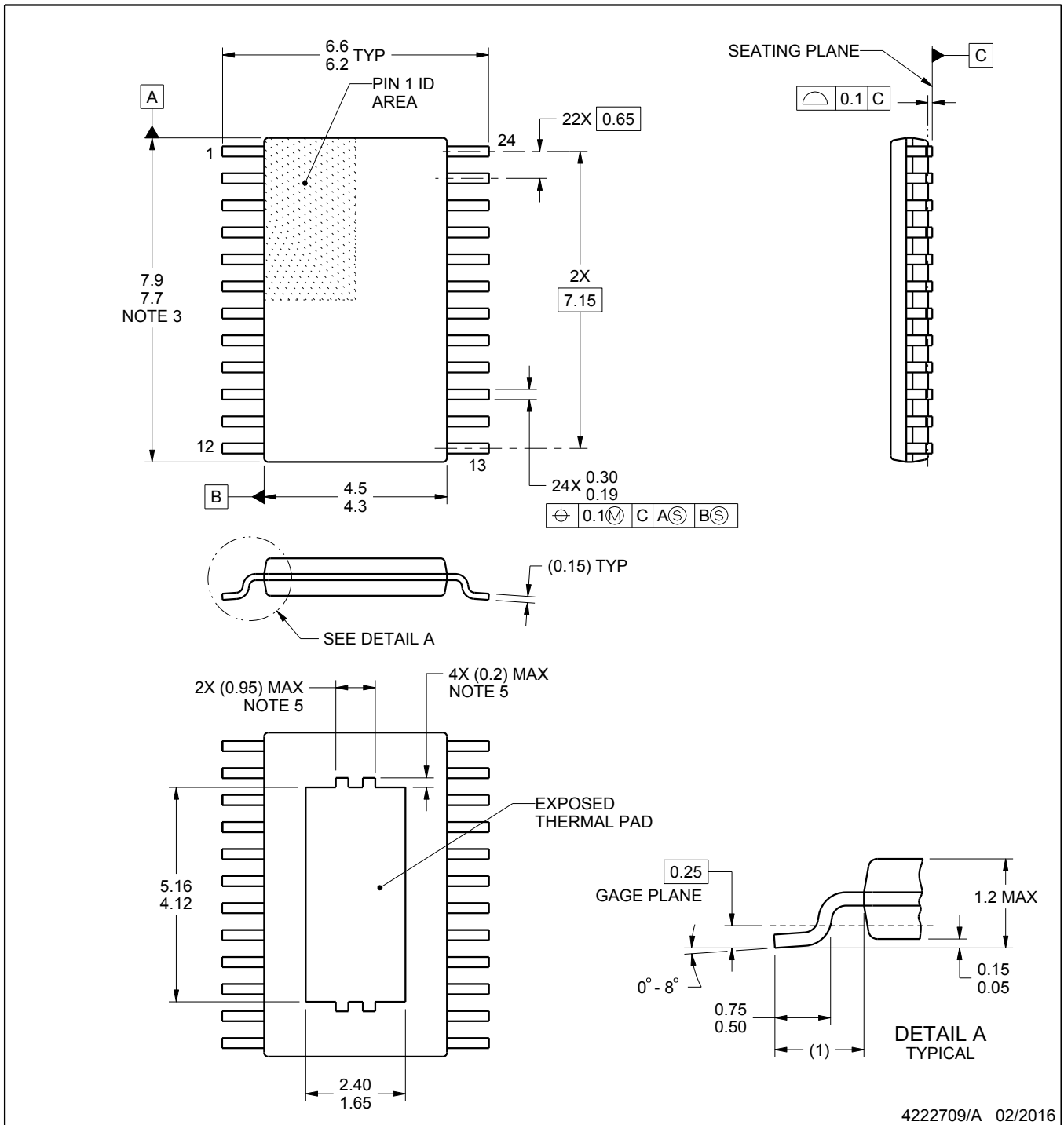

### NOTES:

PowerPAD is a trademark of Texas Instruments.

1. All linear dimensions are in millimeters. Any dimensions in parenthesis are for reference only. Dimensioning and tolerancing per ASME Y14.5M.
2. This drawing is subject to change without notice.
3. This dimension does not include mold flash, protrusions, or gate burrs. Mold flash, protrusions, or gate burrs shall not exceed 0.15 mm per side.
4. Reference JEDEC registration MO-153.
5. Features may not be present and may vary.

# EXAMPLE BOARD LAYOUT

PWP0024B

PowerPAD™ TSSOP - 1.2 mm max height

PLASTIC SMALL OUTLINE

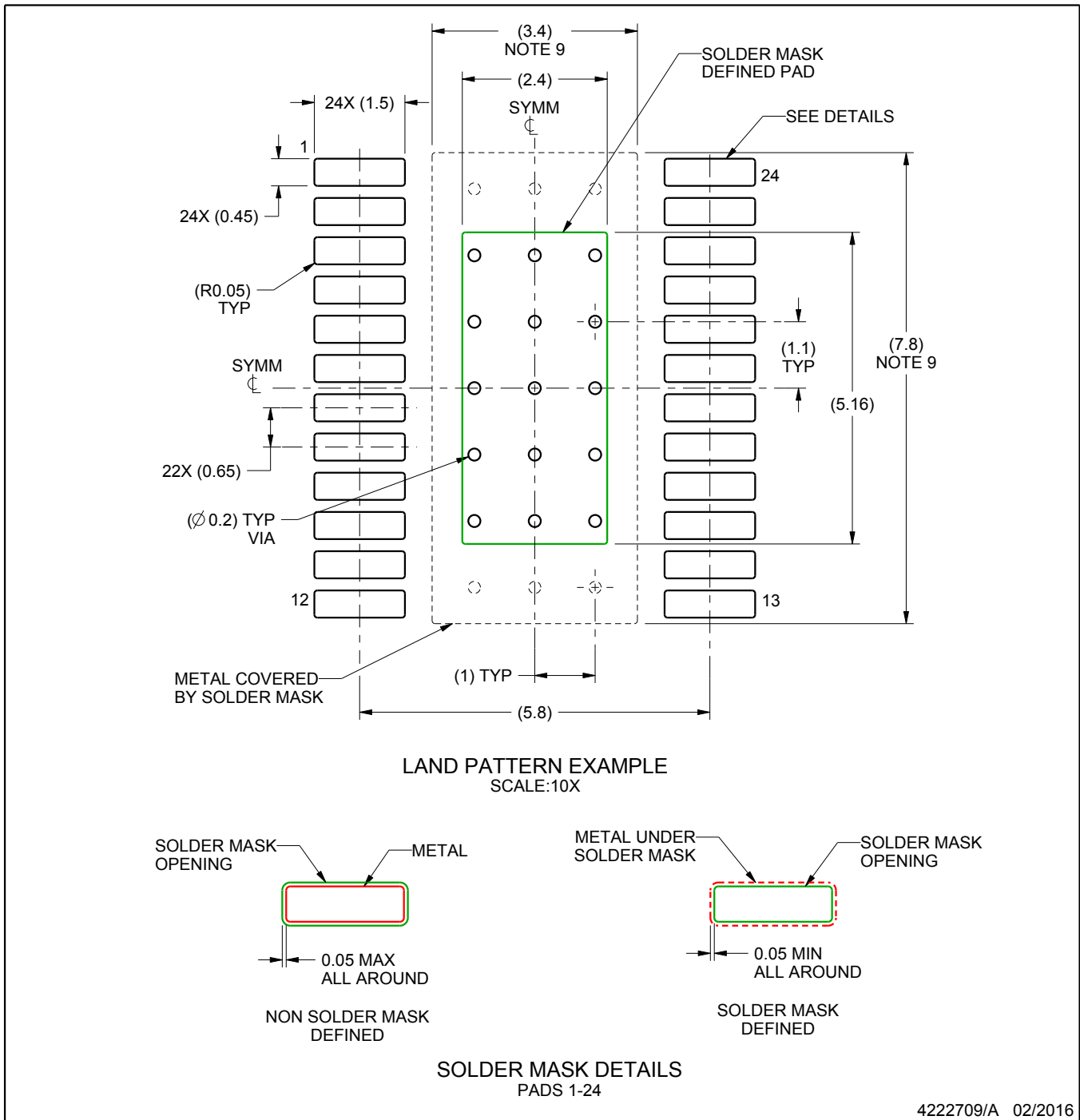

NOTES: (continued)

6. Publication IPC-7351 may have alternate designs.
7. Solder mask tolerances between and around signal pads can vary based on board fabrication site.
8. This package is designed to be soldered to a thermal pad on the board. For more information, see Texas Instruments literature numbers SLMA002 ([www.ti.com/lit/slma002](http://www.ti.com/lit/slma002)) and SLMA004 ([www.ti.com/lit/slma004](http://www.ti.com/lit/slma004)).
9. Size of metal pad may vary due to creepage requirement.

# EXAMPLE STENCIL DESIGN

PWP0024B

PowerPAD™ TSSOP - 1.2 mm max height

PLASTIC SMALL OUTLINE

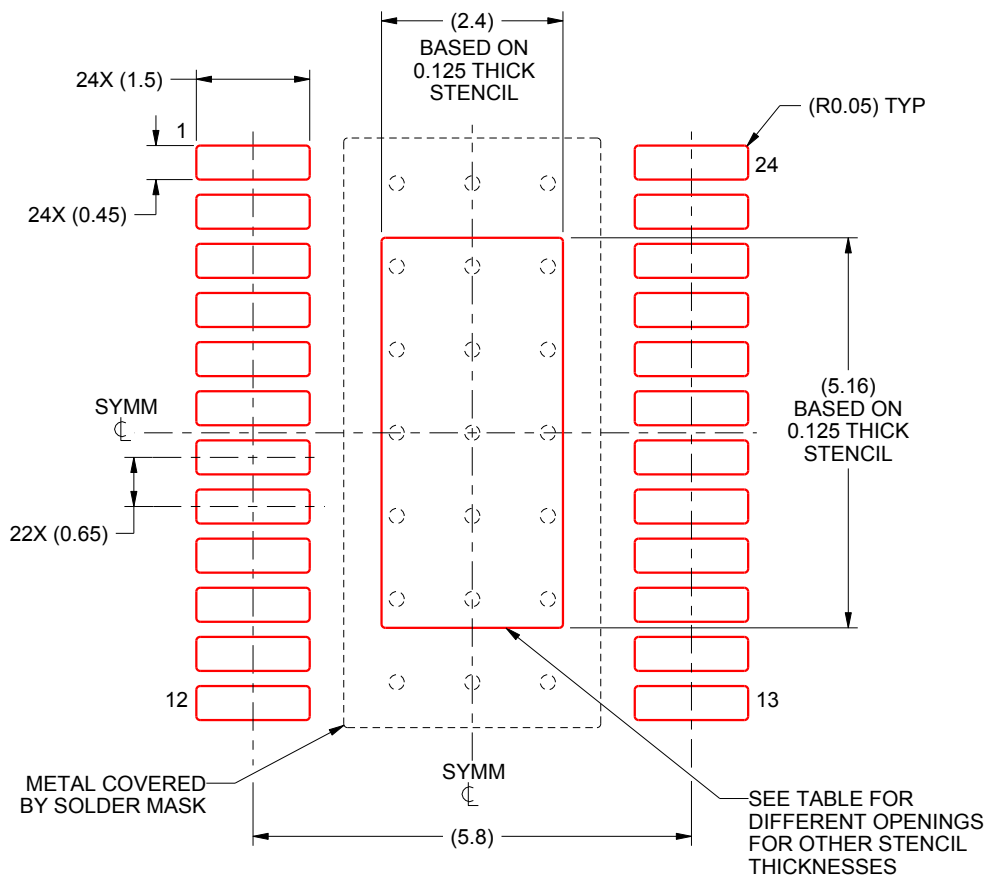

SOLDER PASTE EXAMPLE  
 EXPOSED PAD  
 100% PRINTED SOLDER COVERAGE BY AREA  
 SCALE:10X

STENCIL THICKNESS	SOLDER STENCIL OPENING
0.1	2.68 X 5.77
0.125	2.4 X 5.16 (SHOWN)
0.15	2.19 X 4.71
0.175	2.03 X 4.36

4222709/A 02/2016

NOTES: (continued)

- 10. Laser cutting apertures with trapezoidal walls and rounded corners may offer better paste release. IPC-7525 may have alternate design recommendations.
- 11. Board assembly site may have different recommendations for stencil design.

## GENERIC PACKAGE VIEW

**RHR 28**

**WQFN - 0.8 mm max height**

3.5 x 5.5, 0.5 mm pitch

PLASTIC QUAD FLATPACK - NO LEAD

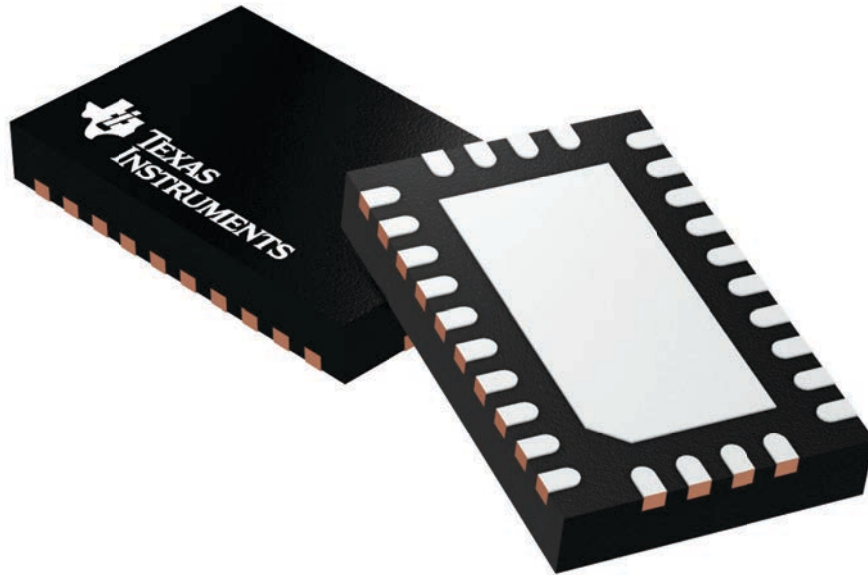

Images above are just a representation of the package family, actual package may vary.  
Refer to the product data sheet for package details.

4210249/B

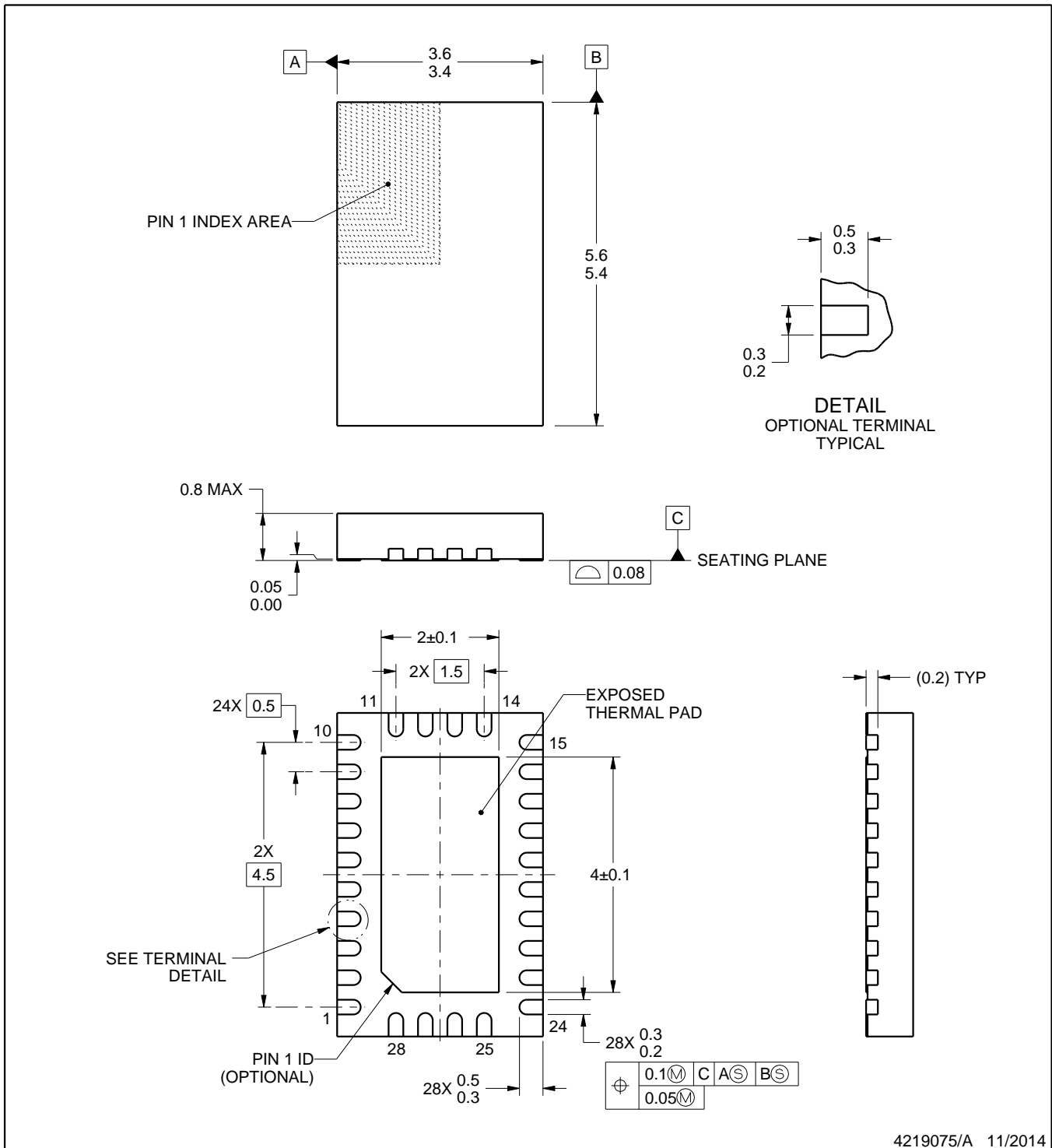

4219075/A 11/2014

NOTES:

1. All linear dimensions are in millimeters. Any dimensions in parenthesis are for reference only. Dimensioning and tolerancing per ASME Y14.5M.
2. This drawing is subject to change without notice.
3. The package thermal pad must be soldered to the printed circuit board for thermal and mechanical performance.



# EXAMPLE BOARD LAYOUT

RHR0028A

WQFN - 0.8 mm max height

PLASTIC QUAD FLATPACK - NO LEAD

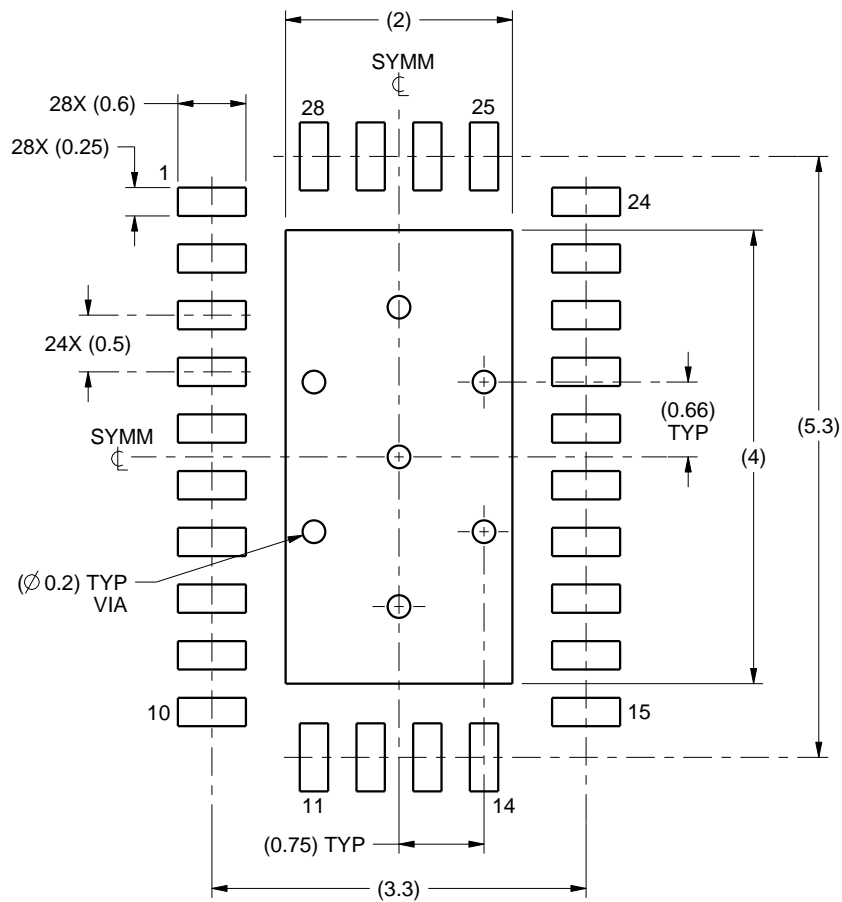

LAND PATTERN EXAMPLE  
SCALE:15X

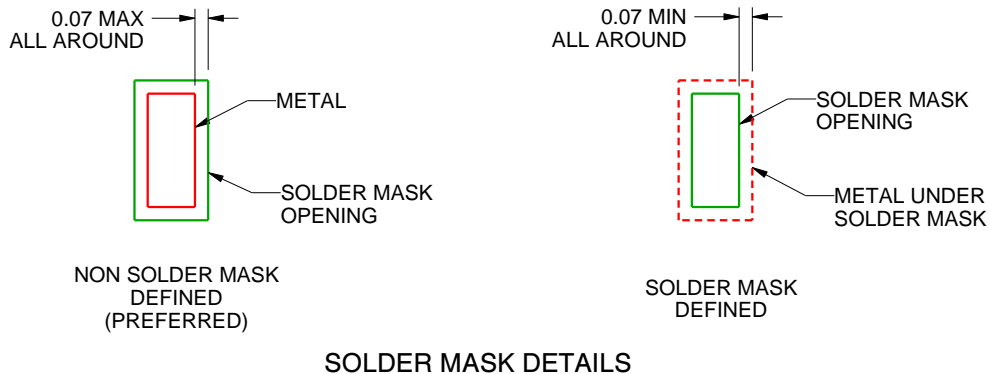

SOLDER MASK DETAILS

4219075/A 11/2014

NOTES: (continued)

4. This package is designed to be soldered to a thermal pad on the board. For more information, see Texas Instruments literature number SLUA271 ([www.ti.com/lit/slua271](http://www.ti.com/lit/slua271)).

# EXAMPLE STENCIL DESIGN

RHR0028A

WQFN - 0.8 mm max height

PLASTIC QUAD FLATPACK - NO LEAD

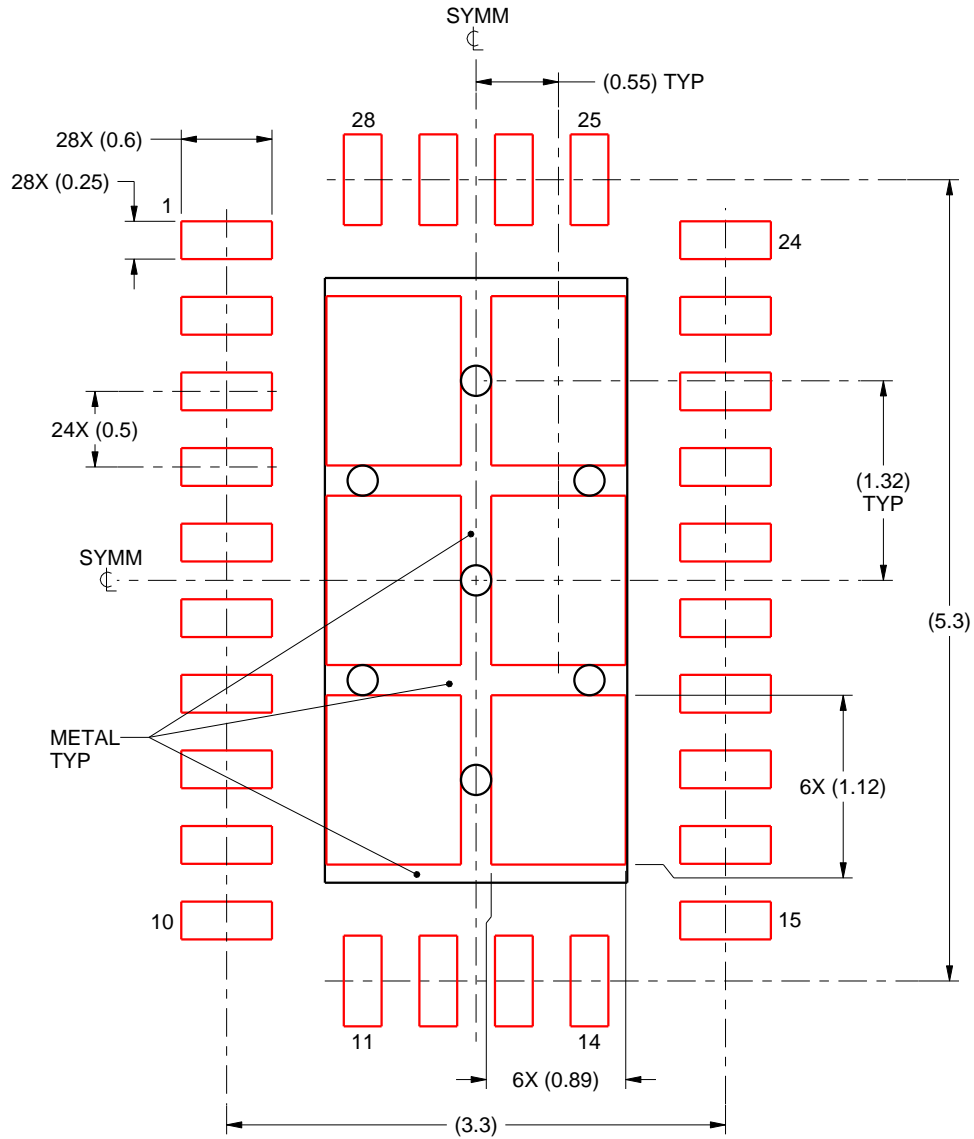

SOLDER PASTE EXAMPLE  
BASED ON 0.125 mm THICK STENCIL

EXPOSED PAD  
75% PRINTED SOLDER COVERAGE BY AREA  
SCALE:20X

4219075/A 11/2014

NOTES: (continued)

5. Laser cutting apertures with trapezoidal walls and rounded corners may offer better paste release. IPC-7525 may have alternate design recommendations.

## IMPORTANT NOTICE AND DISCLAIMER

TI PROVIDES TECHNICAL AND RELIABILITY DATA (INCLUDING DATA SHEETS), DESIGN RESOURCES (INCLUDING REFERENCE DESIGNS), APPLICATION OR OTHER DESIGN ADVICE, WEB TOOLS, SAFETY INFORMATION, AND OTHER RESOURCES "AS IS" AND WITH ALL FAULTS, AND DISCLAIMS ALL WARRANTIES, EXPRESS AND IMPLIED, INCLUDING WITHOUT LIMITATION ANY IMPLIED WARRANTIES OF MERCHANTABILITY, FITNESS FOR A PARTICULAR PURPOSE OR NON-INFRINGEMENT OF THIRD PARTY INTELLECTUAL PROPERTY RIGHTS.

These resources are intended for skilled developers designing with TI products. You are solely responsible for (1) selecting the appropriate TI products for your application, (2) designing, validating and testing your application, and (3) ensuring your application meets applicable standards, and any other safety, security, regulatory or other requirements.

These resources are subject to change without notice. TI grants you permission to use these resources only for development of an application that uses the TI products described in the resource. Other reproduction and display of these resources is prohibited. No license is granted to any other TI intellectual property right or to any third party intellectual property right. TI disclaims responsibility for, and you will fully indemnify TI and its representatives against, any claims, damages, costs, losses, and liabilities arising out of your use of these resources.

TI's products are provided subject to [TI's Terms of Sale](#) or other applicable terms available either on [ti.com](#) or provided in conjunction with such TI products. TI's provision of these resources does not expand or otherwise alter TI's applicable warranties or warranty disclaimers for TI products.

TI objects to and rejects any additional or different terms you may have proposed.

Mailing Address: Texas Instruments, Post Office Box 655303, Dallas, Texas 75265  
Copyright © 2022, Texas Instruments Incorporated