

# DRV8962 Four-channel Half-Bridge Driver with Current Sense Outputs

## 1 Features

- Four-channel half-bridge driver
  - Independent control** of each half-bridge
- 4.5 V to 65 V** operating supply voltage range
- Low  $R_{DS(ON)}$ : **50 mΩ** for each FET (24 V, 25 °C)
- High current capacity:
  - DDW package: Up to **5-A per output**
  - DDV package: Up to **10-A per output**
- Can drive various types of loads -
  - Up to four solenoid loads
  - One stepper motor
  - Two brushed-DC motors
  - One or two thermoelectric coolers (TEC)
  - One 3-phase brushless-DC motor
  - One 3-phase permanent magnet synchronous motor (PMSM)
- Integrated current sense and regulation
  - Current sensing across high-side MOSFETs
  - Sense output (**IPROPI**) for each half-bridge
  - ± 4%** sense accuracy at maximum current
  - Optional external sense resistor
- Pin-to-pin compatible with:
  - DRV8952**: 48V, four-channel half-bridge driver
- Separate logic supply voltage (**VCC**)
- Programmable output rise/fall time
- Programmable fault recovery method
- Supports 1.8-V, 3.3-V, 5.0-V logic inputs
- Low-current sleep mode (3 μA)
- Protection features
  - VM undervoltage lockout (UVLO)
  - Charge pump undervoltage (CPUV)
  - Overcurrent protection (OCP)
  - Thermal shutdown (OTSD)
  - Fault condition output (nFAULT)

## 2 Applications

- [Factory Automation, Stepper Drives and Robotics](#)
- [Medical Imaging, Diagnostics and Equipment](#)
- [Stage Lighting](#)
- [PLCs](#)
- [TEC Drivers](#)
- [BLDC Motor Modules](#)
- [Brushed-DC and Stepper Motor drivers](#)

## 3 Description

The DRV8962 is a wide-voltage, high-power, four-channel half-bridge driver for a wide variety of industrial applications. The device supports up to 65-V supply voltage, and integrated MOSFETs with 50 mΩ on-resistance allow up to 5-A current on each output

with the DDW package; and up to 10-A current per output with the DDV package.

The device can be used for driving up to four solenoid loads, one stepper motor, two brushed-DC motors, one BLDC or PMSM motor and up to two thermoelectric coolers (Peltier elements). The output stage of the device consists of N-channel power MOSFETs configured as four independent half-bridges, charge pump regulator, current sensing and regulation circuits, current sense outputs and protection circuitry.

Integrated current sensing across the high-side MOSFETs allows the device to regulate the current when the load is connected from output to ground. A regulation current limit can be set with an adjustable external voltage reference (VREF). Additionally, the device provides four proportional current output pins, one for each half-bridge high-side FET. Optional external sense resistors can also be connected from the PGND pins to the system ground.

A low-power sleep mode is provided to achieve ultra-low quiescent current. Internal protection features are provided for supply undervoltage lockout (UVLO), charge pump undervoltage (CPUV), output over current (OCP), and device overtemperature (OTSD).

### Device Information

PART NUMBER	PACKAGE <sup>(1)</sup>	BODY SIZE (NOM)
DRV8962DDWR	HTSSOP (44), bottom exposed pad	14 mm x 6.1 mm
DRV8962DDVR	HTSSOP (44), top exposed pad	14 mm x 6.1 mm

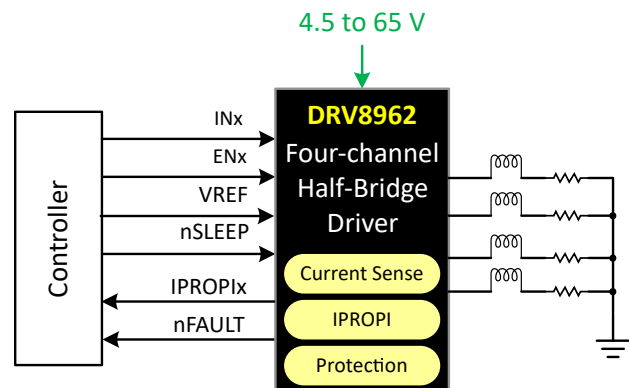

DRV8962 Simplified Schematic



## Table of Contents

<b>1 Features</b> .....	<b>1</b>	<b>8 Application and Implementation</b> .....	<b>21</b>
<b>2 Applications</b> .....	<b>1</b>	8.1 Application Information.....	21
<b>3 Description</b> .....	<b>1</b>	<b>9 Package Thermal Considerations</b> .....	<b>33</b>
<b>4 Revision History</b> .....	<b>2</b>	9.1 DDW Package.....	33
<b>5 Pin Configuration and Functions</b> .....	<b>3</b>	9.2 DDV Package.....	33
<b>6 Specifications</b> .....	<b>6</b>	9.3 PCB Material Recommendation.....	34
6.1 Absolute Maximum Ratings.....	6	<b>10 Power Supply Recommendations</b> .....	<b>35</b>
6.2 ESD Ratings.....	6	10.1 Bulk Capacitance.....	35
6.3 Recommended Operating Conditions.....	6	10.2 Power Supplies.....	35
6.4 Thermal Information.....	7	<b>11 Layout</b> .....	<b>36</b>
6.5 Electrical Characteristics.....	8	11.1 Layout Guidelines.....	36
<b>7 Detailed Description</b> .....	<b>10</b>	11.2 Layout Example.....	36
7.1 Overview.....	10	<b>12 Device and Documentation Support</b> .....	<b>37</b>
7.2 Functional Block Diagram.....	11	12.1 Related Documentation.....	37
7.3 Feature Description.....	11	12.2 Receiving Notification of Documentation Updates..	37
7.4 Independent Half-bridge Operation.....	12	12.3 Support Resources.....	37
7.5 Current Sensing and Regulation.....	13	12.4 Trademarks.....	37
7.6 Charge Pump.....	16	12.5 Electrostatic Discharge Caution.....	37
7.7 Linear Voltage Regulator.....	17	12.6 Glossary.....	37
7.8 VCC Voltage Supply.....	17	<b>13 Mechanical, Packaging, and Orderable Information</b> .....	<b>38</b>
7.9 Logic Level Pin Diagram.....	18	13.1 Tape and Reel Information.....	45
7.10 Protection Circuits.....	18		
7.11 Device Functional Modes.....	20		

## 4 Revision History

NOTE: Page numbers for previous revisions may differ from page numbers in the current version.

DATE	REVISION	NOTES
	*	Initial Release

## 5 Pin Configuration and Functions

The DRV8962 is available in thermally-enhanced, 44-Pin HTSSOP packages.

- The DDW package contains a PowerPAD™ on the bottom side of the device.
- The DDV package contains a PowerPAD™ on the top side of the device for thermal coupling to a heatsink.

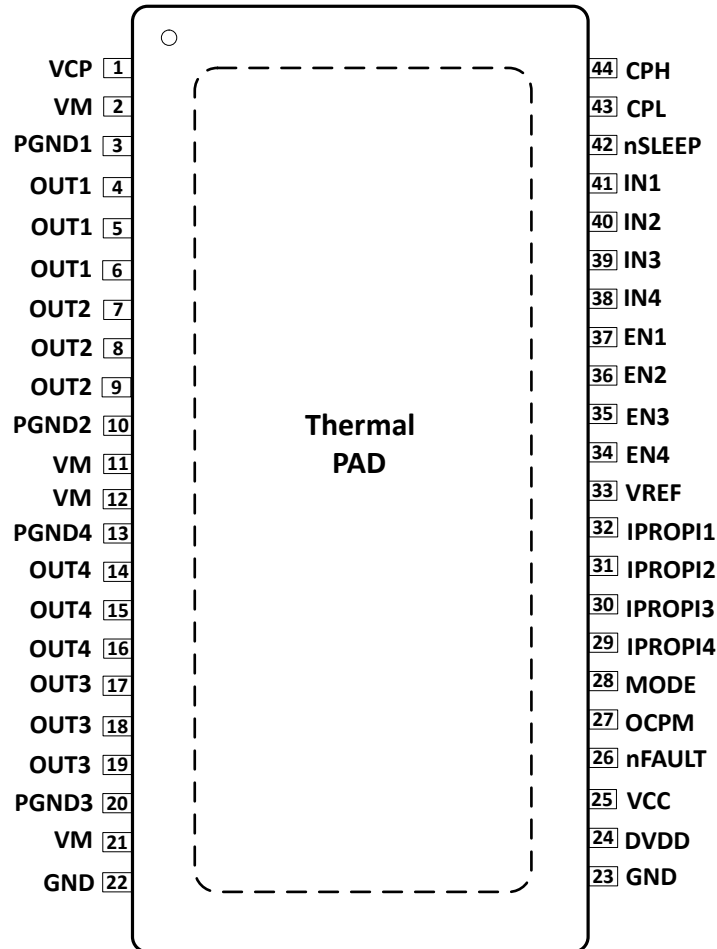

Figure 5-1. DDW Package, Top View

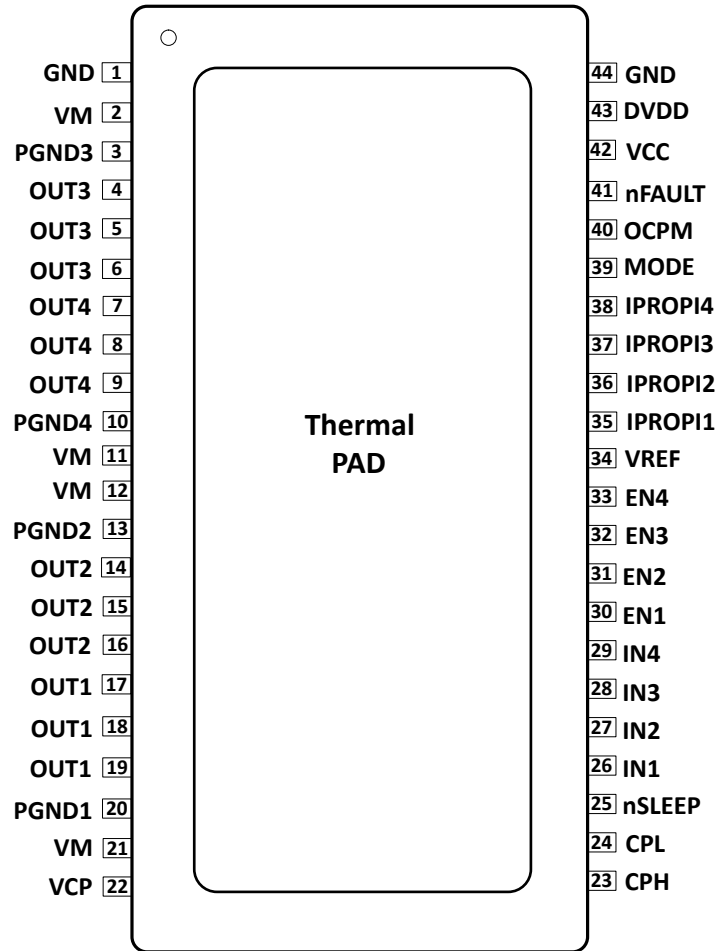

Figure 5-2. DDV Package, Top View

NAME	PIN		TYPE	DESCRIPTION
	DDW	DDV		
VCP	1	22	Power	Charge pump output. Connect a X7R, 1- $\mu$ F, 16-V ceramic capacitor from VCP to VM.
VM	2, 11, 12, 21	2, 11, 12, 21	Power	Power supply. Connect to motor supply voltage and bypass to PGND pins with 0.01- $\mu$ F ceramic capacitors plus a bulk capacitor rated for VM.
PGND1	3	20	Power	Power ground for half-bridge 1. Connect to system ground.
PGND2	10	13	Power	Power ground for half-bridge 2. Connect to system ground.
PGND3	20	3	Power	Power ground for half-bridge 3. Connect to system ground.
PGND4	13	10	Power	Power ground for half-bridge 4. Connect to system ground.
OUT1	4, 5, 6	17, 18, 19	Output	Connect to load terminal.
OUT2	7, 8, 9	14, 15, 16	Output	Connect to load terminal.
OUT3	17, 18, 19	4, 5, 6	Output	Connect to load terminal.
OUT4	14, 15, 16	7, 8, 9	Output	Connect to load terminal.
IPROPI1	32	35	Output	Current sense output for half-bridge 1.
IPROPI2	31	36	Output	Current sense output for half-bridge 2.
IPROPI3	30	37	Output	Current sense output for half-bridge 3.
IPROPI4	29	38	Output	Current sense output for half-bridge 4.

PIN			TYPE	DESCRIPTION
NAME	DDW	DDV		
EN1	37	30	Input	Enable input of half-bridge 1.
EN2	36	31	Input	Enable input of half-bridge 2.
EN3	35	32	Input	Enable input of half-bridge 3.
EN4	34	33	Input	Enable input of half-bridge 4.
IN1	41	26	Input	PWM input for half-bridge 1.
IN2	40	27	Input	PWM input for half-bridge 2.
IN3	39	28	Input	PWM input for half-bridge 3.
IN4	38	29	Input	PWM input for half-bridge 4.
GND	22, 23	1, 44	Power	Device ground. Connect to system ground.
CPH	44	23	Power	Charge pump switching node. Connect a X7R, 0.022- $\mu$ F, VM rated ceramic capacitor from CPH to CPL.
CPL	43	24		
VREF	33	34	Input	Voltage reference input for setting current regulation threshold. DVDD can be used to provide VREF through a resistor divider.
DVDD	24	43	Power	Internal LDO output. Connect a X7R, 0.47- $\mu$ F to 1- $\mu$ F, 6.3-V or 10-V rated ceramic capacitor to GND.
VCC	25	42	Power	Supply voltage for internal logic blocks. When separate logic supply voltage is not available, tie the VCC pin to the DVDD pin.
nFAULT	26	41	Open Drain	Fault indication output. Pulled logic low with fault condition. Open drain output requires an external pullup resistor.
MODE	28	39	Input	This pin programs the output rise/fall time.
OCPM	27	40	Input	Determines the fault recovery method. Depending on the OCPM voltage, fault recovery can be either latch-off or auto-retry type.
nSLEEP	42	25	Input	Sleep mode input. Logic high to enable device; logic low to enter low-power sleep mode. A narrow nSLEEP reset pulse clears latched faults.
PAD	-	-	-	Thermal pad.

## 6 Specifications

### 6.1 Absolute Maximum Ratings

Over operating free-air temperature range (unless otherwise noted).

	MIN	MAX	UNIT
Power supply voltage (VM)	-0.3	70	V
Charge pump voltage (VCP, CPH)	-0.3	$V_{VM} + 5.75$	V
Charge pump negative switching pin (CPL)	-0.3	$V_{VM}$	V
nSLEEP pin voltage (nSLEEP)	-0.3	$V_{VM}$	V
Internal regulator voltage (DVDD)	-0.3	5.75	V
External logic supply (VCC)	-0.3	5.75	V
IPROPI pin voltage (IPROPI)	-0.3	$DVDD + 0.3$	V
Control pin voltage	-0.3	5.75	V
Open drain output current (nFAULT)	0	10	mA
Reference input pin voltage (VREF)	-0.3	5.75	V
PGNDx to GND voltage	-0.5	0.5	V
PGNDx to GND voltage, < 1 $\mu$ s	-2.5	2.5	V
Continuous OUTx pin voltage	-1	$V_{VM} + 1$	V
Transient 100 ns OUTx pin voltage	-3	$V_{VM} + 3$	V
Peak drive current	Internally Limited		A
Operating ambient temperature, $T_A$	-40	125	$^{\circ}$ C
Operating junction temperature, $T_J$	-40	150	$^{\circ}$ C
Storage temperature, $T_{stg}$	-65	150	$^{\circ}$ C

- Stresses beyond those listed under *absolute maximum ratings* may cause permanent damage to the device. These are stress ratings only and functional operation of the device at these or any other conditions beyond those indicated under *recommended operating conditions* is not implied. Exposure to absolute-maximum-rated conditions for extended periods may affect device reliability.
- All voltage values are with respect to network ground terminal GND.

### 6.2 ESD Ratings

			VALUE	UNIT	
$V_{(ESD)}$	Electrostatic discharge	Human-body model (HBM), per ANSI/ESDA/JEDEC JS-001 <sup>(1)</sup>	$\pm 2000$	V	
		Charged-device model (CDM), per ANSI/ESDA/JEDEC JS-002 <sup>(2)</sup>	Corner pins		$\pm 750$
			Other pins		$\pm 500$

(1) JEDEC document JEP155 states that 500-V HBM allows safe manufacturing with a standard ESD control process.

(2) JEDEC document JEP157 states that 250-V CDM allows safe manufacturing with a standard ESD control process.

### 6.3 Recommended Operating Conditions

over operating free-air temperature range (unless otherwise noted)

		MIN	MAX	UNIT
$V_{VM}$	Supply voltage range for normal (DC) operation	4.5	65	V
$V_I$	Logic level input voltage	0	5.5	V
$V_{VCC}$	VCC pin voltage	3.05	5.5	V
$V_{REF}$	Reference voltage (VREF)	0.05	3.3	V
$f_{PWM}$	Applied PWM signal	0	200	kHz
$I_{DDW}$	Current per output, DDW Package	0	5	A

over operating free-air temperature range (unless otherwise noted)

		MIN	MAX	UNIT
$I_{DDV}$	Current per output, DDV Package	0	10	A
$T_A$	Operating ambient temperature	-40	125	°C
$T_J$	Operating junction temperature	-40	150	°C

## 6.4 Thermal Information

THERMAL METRIC		DDW	DDV	UNIT
$R_{\theta JA}$	Junction-to-ambient thermal resistance	22.2	44.2	°C/W
$R_{\theta JC(top)}$	Junction-to-case (top) thermal resistance	9.1	0.7	°C/W
$R_{\theta JB}$	Junction-to-board thermal resistance	5.3	18.9	°C/W
$\psi_{JT}$	Junction-to-top characterization parameter	0.1	0.3	°C/W
$\psi_{JB}$	Junction-to-board characterization parameter	5.3	18.6	°C/W
$R_{\theta JC(bot)}$	Junction-to-case (bottom) thermal resistance	0.7	N/A	°C/W

## 6.5 Electrical Characteristics

Typical values are at  $T_A = 25^\circ\text{C}$  and  $V_{VM} = 24\text{ V}$ . All limits are over recommended operating conditions, unless otherwise noted.

PARAMETER		TEST CONDITIONS	MIN	TYP	MAX	UNIT
<b>POWER SUPPLIES (VM, DVDD)</b>						
$I_{VM}$	VM operating supply current	nSLEEP = 1, No load, VCC = External 5V		4	7	mA
		nSLEEP = 1, No load, VCC = DVDD		6	9	
$I_{VMQ}$	VM sleep mode supply current	nSLEEP = 0		3	8	$\mu\text{A}$
$t_{SLEEP}$	Sleep time	nSLEEP = 0 to sleep-mode	120			$\mu\text{s}$
$t_{RESET}$	nSLEEP reset pulse	nSLEEP low to clear fault	20		40	$\mu\text{s}$
$t_{WAKE}$	Wake-up time	nSLEEP = 1 to output transition		0.8	1.2	ms
$t_{ON}$	Turn-on time	VM > UVLO to output transition		0.8	1.3	ms
$V_{DVDD}$	Internal regulator voltage	No external load, $6\text{ V} < V_{VM} < 65\text{ V}$	4.75	5	5.25	V
		No external load, $V_{VM} = 4.5\text{ V}$	4.2	4.35		V
<b>CHARGE PUMP (VCP, CPH, CPL)</b>						
$V_{VCP}$	VCP operating voltage	$6\text{ V} < V_{VM} < 65\text{ V}$		$V_{VM} + 5$		V
$f_{(VCP)}$	Charge pump switching frequency	$V_{VM} > UVLO$ ; nSLEEP = 1		360		kHz
<b>LOGIC-LEVEL INPUTS (IN1, IN2, IN3, IN4, EN1, EN2, EN3, EN4, MODE, OCPM, nSLEEP)</b>						
$V_{IL}$	Input logic-low voltage		0		0.6	V
$V_{IH}$	Input logic-high voltage		1.5		5.5	V
$V_{HYS}$	Input logic hysteresis			150		mV
$I_{IL}$	Input logic-low current	$V_{IN} = 0\text{ V}$	-1		1	$\mu\text{A}$
$I_{IH}$	Input logic-high current	$V_{IN} = DVDD$			50	$\mu\text{A}$
$t_1$	ENx high to OUTx high delay	INx = 1			2	$\mu\text{s}$
$t_2$	ENx low to OUTx low delay	INx = 1			2	$\mu\text{s}$
$t_3$	ENx high to OUTx low delay	INx = 0			2	$\mu\text{s}$
$t_4$	ENx low to OUTx high delay	INx = 0			2	$\mu\text{s}$
$t_5$	INx high to OUTx high delay			600		ns
$t_6$	INx low to OUTx low delay			600		ns
<b>CONTROL OUTPUTS (nFAULT)</b>						
$V_{OL}$	Output logic-low voltage	$I_O = 5\text{ mA}$			0.5	V
$I_{OH}$	Output logic-high leakage		-1		1	$\mu\text{A}$
<b>MOTOR DRIVER OUTPUTS (OUT1, OUT2, OUT3, OUT4)</b>						
$R_{DS(ONH)}$	High-side FET on resistance	$T_J = 25^\circ\text{C}$ , $I_O = -5\text{ A}$		50	60	$\text{m}\Omega$
		$T_J = 125^\circ\text{C}$ , $I_O = -5\text{ A}$		75	90	$\text{m}\Omega$
		$T_J = 150^\circ\text{C}$ , $I_O = -5\text{ A}$		85	105	$\text{m}\Omega$
$R_{DS(ONL)}$	Low-side FET on resistance	$T_J = 25^\circ\text{C}$ , $I_O = 5\text{ A}$		50	60	$\text{m}\Omega$
		$T_J = 125^\circ\text{C}$ , $I_O = 5\text{ A}$		75	90	$\text{m}\Omega$
		$T_J = 150^\circ\text{C}$ , $I_O = 5\text{ A}$		85	105	$\text{m}\Omega$
$t_{RF}$	Output rise/fall time	$I_O = 5\text{ A}$ , MODE = 1, between 10% and 90%		70		ns
		$I_O = 5\text{ A}$ , MODE = 0, between 10% and 90%		140		ns
$t_D$	Output dead time	VM = 24V, $I_O = 5\text{ A}$		300		ns



Typical values are at  $T_A = 25^\circ\text{C}$  and  $V_{VM} = 24\text{ V}$ . All limits are over recommended operating conditions, unless otherwise noted.

PARAMETER	TEST CONDITIONS	MIN	TYP	MAX	UNIT	
<b>CURRENT SENSE AND REGULATION (IPROPI, VREF)</b>						
$A_{IPROPI}$	Current mirror gain		212		$\mu\text{A/A}$	
$A_{ERR}$	Current mirror scaling error	10% to 20% rated current	-8.5	8.5	%	
		20% to 40% rated current	-5	5		
		40% to 100% rated current	-4	4		
$I_{VREF}$	VREF Leakage Current	VREF = 3.3 V		100	nA	
$t_{OFF}$	PWM off-time		16		$\mu\text{s}$	
$t_{DEG}$	Current regulation deglitch time		0.5		$\mu\text{s}$	
$t_{BLK}$	Current Regulation Blanking time		1.5		$\mu\text{s}$	
<b>PROTECTION CIRCUITS</b>						
$V_{UVLO}$	VM UVLO lockout	VM falling	4.1	4.25	4.35	V
		VM rising	4.2	4.35	4.45	
$V_{CCUVLO}$	VCC UVLO lockout	VCC falling	2.7	2.8	2.9	V
		VCC rising	2.8	2.9	3.05	
$V_{UVLO,HYS}$	Undervoltage hysteresis	Rising to falling threshold		100	mV	
$V_{CPUV}$	Charge pump undervoltage	VCP falling		$V_{VM} + 2$	V	
$I_{OCP}$	Overcurrent protection	Current through any FET, DDW Package	8			A
		Current through any FET, DDV Package	16			A
$t_{OCP}$	Overcurrent detection delay		2		$\mu\text{s}$	
$t_{RETRY}$	Overcurrent retry time		4		ms	
$T_{OTSD}$	Thermal shutdown	Die temperature $T_J$	150	165	180	$^\circ\text{C}$
$T_{HYS\_OTSD}$	Thermal shutdown hysteresis	Die temperature $T_J$		20		$^\circ\text{C}$

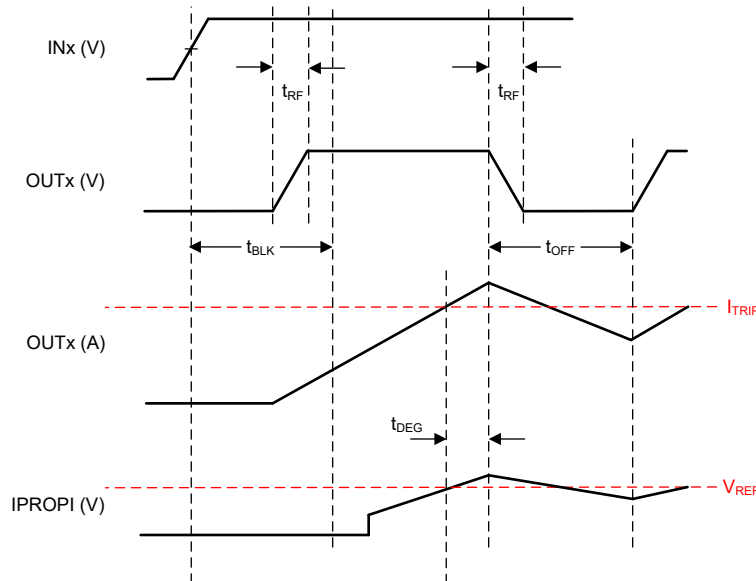

**Figure 6-1. IPROPI Timing Diagram**

## 7 Detailed Description

### 7.1 Overview

The DRV8962 is a four-channel half-bridge driver that operates from 4.5 V to 65 V and supports a wide range of load currents for various types of loads. The device integrates four half-bridge output power stages. The device integrates a charge pump regulator to support efficient high-side N-channel MOSFETs and 100% duty cycle operation. The DRV8962 can operate from a single power supply input (VM). Alternatively, the VCC pin can be connected to a second power supply to provide power to the internal logic blocks. The nSLEEP pin provides an ultra-low power mode to minimize current draw during system inactivity.

The device is available in two packages - a 44-pin HTSSOP (DDW) package with exposed pad at the bottom of the package; and another 44-pin HTSSOP (DDV) package with exposed pad on the top of the package. The DDW package provides up to 5-A current per output. When used with a low thermal resistance heat sink installed on the top of the DDV package, the DRV8962 can deliver up to 10-A per output. The DRV8962 DDW package is pin-to-pin compatible with the [DRV8952](#), which is rated for 48 V maximum operating voltage. The actual current that can be delivered depends on the ambient temperature, supply voltage, and PCB thermal design.

The DRV8962 provides current sense outputs. The IPROPI pins source a small current that is proportional to the current in the high-side MOSFETs. The current from the IPROPI pins can be converted to a proportional voltage using an external resistor ( $R_{IPROPI}$ ). The integrated current sensing allows the DRV8962 to limit the output current with a fixed off-time PWM chopping scheme and provide load information to the external controller to detect changes in load. The sense accuracy of the IPROPI output is  $\pm 4\%$  for 40% to 100% of rated current. External power sense resistors can also be connected if higher accuracy sensing is required. The current regulation level can be configured during operation through the VREF pin to limit the load current according to the system demands.

A variety of integrated protection features protect the device in the case of a system fault. These include undervoltage lockout (UVLO), charge pump undervoltage (CPUV), over current protection (OCP), and over temperature shutdown (OTSD). Fault conditions are indicated on the nFAULT pin.

## 7.2 Functional Block Diagram

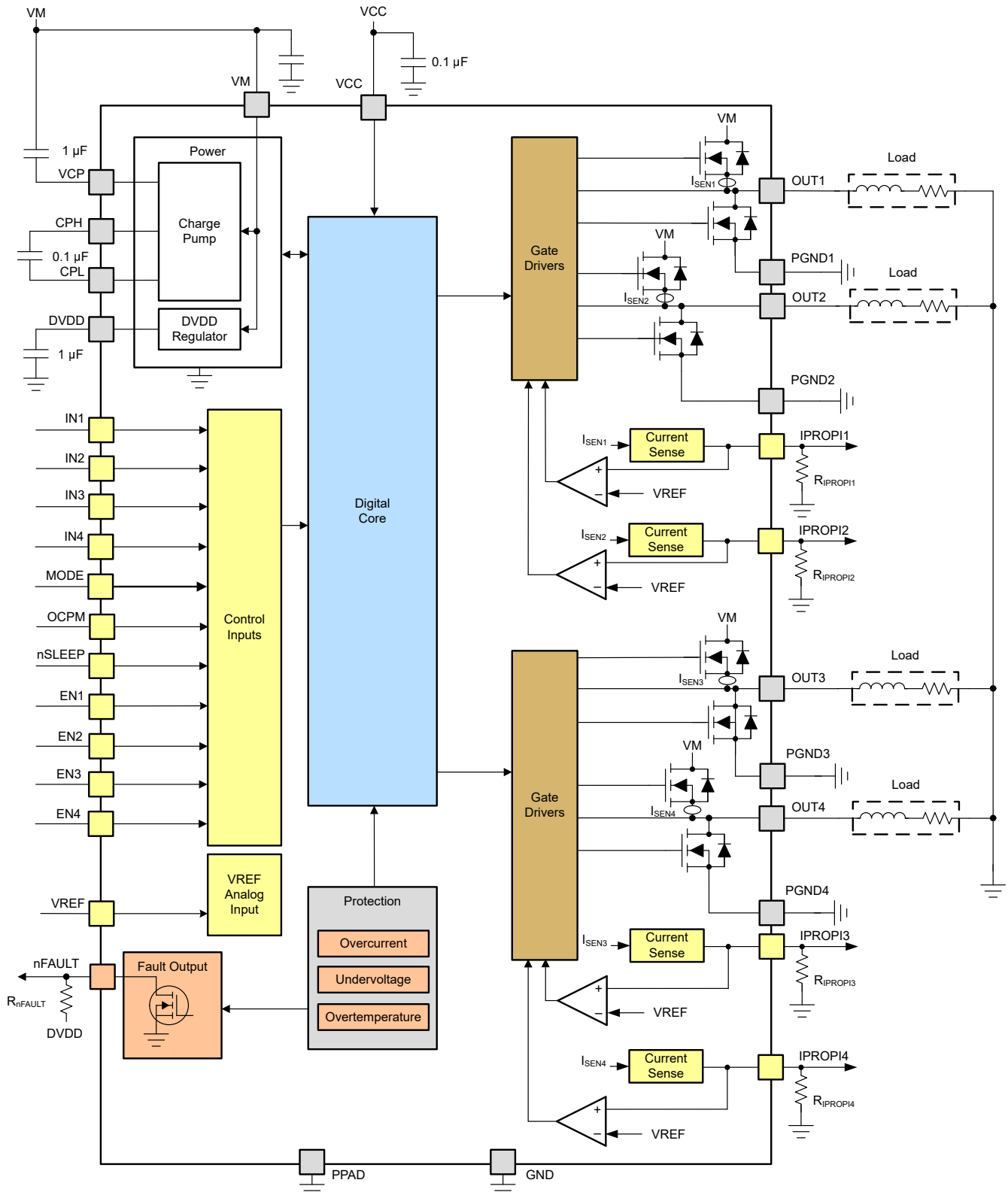

ADVANCE INFORMATION

## 7.3 Feature Description

The following table shows the recommended values of the external components for the DRV8962.

**Table 7-1. External Components**

COMPONENT	PIN 1	PIN 2	RECOMMENDED
C <sub>VM1</sub>	VM	PGND1	X7R, 0.01-μF, VM-rated ceramic capacitor
C <sub>VM2</sub>	VM	PGND3	X7R, 0.01-μF, VM-rated ceramic capacitor
C <sub>VM3</sub>	VM	PGND1	Bulk, VM-rated capacitor
C <sub>VCP</sub>	VCP	VM	X7R, 1-μF, 16-V ceramic capacitor
C <sub>SW</sub>	CPH	CPL	X7R, 0.1-μF, VM-rated ceramic capacitor
C <sub>DVDD</sub>	DVDD	GND	X7R, 1-μF, 6.3-V or 10-V rated ceramic capacitor
C <sub>VCC</sub>	VCC	GND	X7R, 0.1-μF, 6.3-V or 10-V rated ceramic capacitor
R <sub>nFAULT</sub>	DVDD or VCC	nFAULT	10-kΩ resistor
R <sub>REF1</sub>	VREF	DVDD	Resistors to set current regulation threshold.
R <sub>REF2</sub>	VREF	GND	
R <sub>I<sub>PROPIx</sub></sub>	I <sub>PROPIx</sub>	GND	For details, see <a href="#">Section 7.5.3</a>

## 7.4 Independent Half-bridge Operation

- The DRV8962 can drive four half-bridge loads simultaneously.
- The MODE pin configures the typical output rise and fall times to 70 ns or 140 ns.
- The ENx pins enable or disable (Hi-Z) the outputs.
- The INx pins control the state (high or low) of the outputs
  - The INx pins can accept static or pulse-width modulated (PWM) signals.
  - The INx and ENx inputs can be powered before VM is applied.
- The truth table does not take into account the internal current regulation feature.
- The device automatically handles the dead time generation when switching between the high-side and low-side MOSFET of a half-bridge.

**Table 7-2. Independent Half-Bridge Operation Truth Table**

nSLEEP	INx	ENx	OUTx	DESCRIPTION
0	X	X	Hi-Z	Sleep mode, all half-bridges disabled (Hi-Z)
1	X	0	Hi-Z	Individual outputs disabled (Hi-Z)
1	0	1	L	OUTx Low-side ON
1	1	1	H	OUTx High-side ON

The inputs can also be used for PWM control of, for example, the speed of a DC motor. When controlling a winding with PWM, when the drive current is interrupted, the inductive nature of the motor requires that the current must continue to flow. This is called recirculation current. To handle this recirculation current, the H-bridge can operate in two different states, fast decay or slow decay. In fast decay mode, the H-bridge is disabled and recirculation current flows through the body diodes; in slow decay, the motor winding is shorted.

To PWM using fast decay, the PWM signal is applied to the ENx pin; to use slow decay, the PWM signal is applied to the INx pin. The following table is an example of driving a DC motor using OUT1 and OUT2 as an H-bridge:

**Table 7-3. PWM Function**

IN1	EN1	IN2	EN2	FUNCTION
1	1	PWM	1	Forward PWM, slow decay
PWM	1	1	1	Reverse PWM, slow decay
1	PWM	0	PWM	Forward PWM, fast decay
0	PWM	1	PWM	Reverse PWM, fast decay

## 7.5 Current Sensing and Regulation

The DRV8962 integrates current sensing across the high-side MOSFETs, current regulation, and current sense feedback. These features allow the device to sense the load current when the load is connected between output nodes and ground, without connecting an external sense resistor or sense circuitry; reducing system size, cost, and complexity. The current sense proportional outputs (IPROPI) allow the device to give detailed feedback to the controller about the load current.

### 7.5.1 Current Sensing and Feedback

The DRV8962 supports four IPROPI outputs, one for each half-bridge. The IPROPI outputs represent the current of each high-side MOSFET, as shown below -

$$I_{\text{PROPI}} = I_{\text{HS}} \times A_{\text{IPROPI}} \quad (1)$$

Where  $I_{\text{HS}}$  is the current flowing through the high-side MOSFET and  $A_{\text{IPROPI}}$  is the current mirror gain.

Each IPROPI pin should be connected to an external resistor ( $R_{\text{IPROPI}}$ ) to ground in order to generate a proportional voltage ( $V_{\text{IPROPI}}$ ) on the IPROPI pin. This allows the current to be measured as the voltage drop across the  $R_{\text{IPROPI}}$  resistor with a standard analog to digital converter (ADC). The  $R_{\text{IPROPI}}$  resistor can be sized based on the expected load current in the application so that the full range of the controller ADC is utilized. The device implements an internal clamp circuit to limit  $V_{\text{IPROPI}}$  with respect to  $V_{\text{VREF}}$  on the VREF pin and protect the external ADC in case of output overcurrent or unexpected high current events. The IPROPI voltage should be less than the maximum recommended value of VREF, which is 3.3V.

The corresponding IPROPI voltage to the output current can be calculated as shown below -

$$V_{\text{IPROPI}} (\text{V}) = I_{\text{PROPI}} (\text{A}) \times R_{\text{IPROPI}} (\Omega) \quad (2)$$

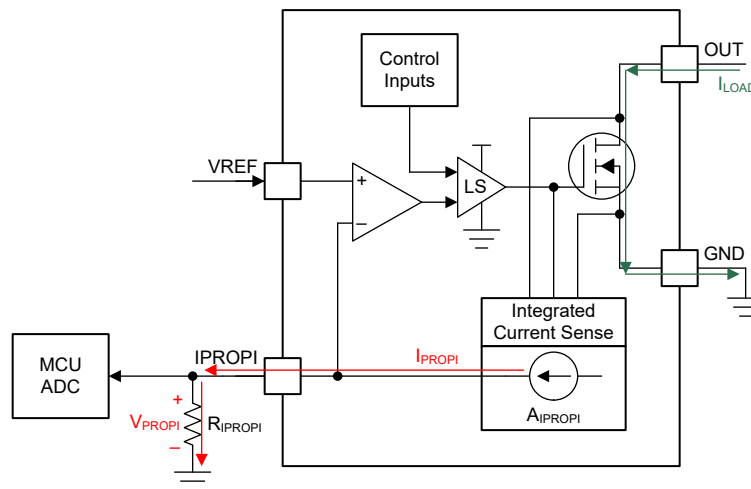
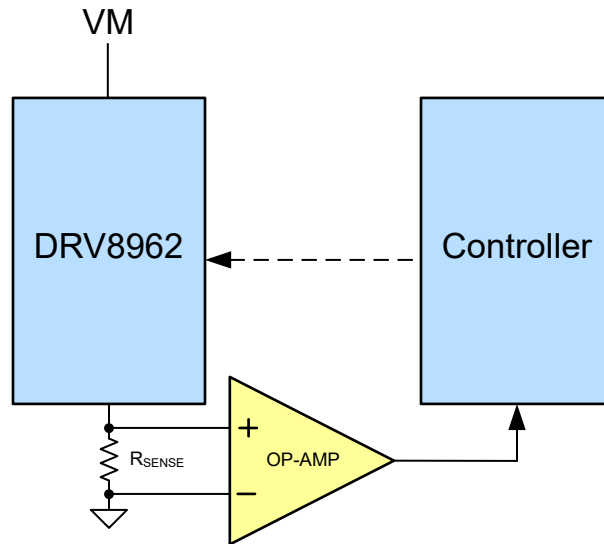

Figure 7-1. Integrated Current Sensing

The  $A_{\text{ERR}}$  parameter in the Electrical Characteristics table is the error associated with the  $A_{\text{IPROPI}}$  gain. It indicates the combined effect of offset error added to the  $I_{\text{OUT}}$  current and gain error.

### 7.5.2 Current Sensing with External Resistor

The IPROPI output accuracy is  $\pm 4\%$  for 40% to 100% of rated current. If more accurate current sensing is desired, external sense resistors can also be used between the PGND pins and the system ground to sense the load currents, as shown below.



**Figure 7-2. Current Sensing with External Resistor**

The voltage drop across the external sense resistor should not exceed 300 mV.

Place the sense resistors as close as possible to the corresponding IC pins. Use a symmetrical sense resistor layout to ensure good matching. Low-inductance sense resistors should be used to prevent voltage spikes and ringing. For optimal performance, the sense resistor should be a surface-mount resistor rated for high enough power.

### 7.5.3 Current Regulation

The current chopping threshold ( $I_{TRIP}$ ) is set through a combination of the VREF voltage ( $V_{VREF}$ ) and IPROPI output resistor ( $R_{IPROPI}$ ). This is done by comparing the voltage drop across the external  $R_{IPROPI}$  resistor to  $V_{VREF}$  with an internal comparator.

$$I_{TRIP} \times A_{IPROPI} = V_{VREF} (V) / R_{IPROPI} (\Omega) \quad (3)$$

For example, to set  $I_{TRIP}$  at 5 A with  $V_{VREF}$  at 3.3 V,  $R_{IPROPI}$  has to be -

$$R_{IPROPI} = V_{VREF} / (I_{TRIP} \times A_{IPROPI}) = 3.3 / (5 \times 212 \times 10^{-6}) = 3.09 \text{ k}\Omega$$

The internal current regulation can be disabled by tying IPROPI to GND and setting the VREF pin voltage greater than GND (if current feedback is not required). If current feedback is required and current regulation is not required, set  $V_{VREF}$  and  $R_{IPROPI}$  such that  $V_{IPROPI}$  never reaches the  $V_{VREF}$  threshold.

The DRV8962 can simultaneously drive up to four resistive or inductive loads. When an output load is connected to ground, the load current can be regulated to the  $I_{TRIP}$  level. The PWM off-time ( $t_{OFF}$ ) is fixed at 16  $\mu$ s. The fixed off-time mode allows for a simple current chopping scheme without involvement from the external controller. Fixed off-time mode will support 100% duty cycle current regulation.

Another way of controlling the load current is the cycle-by-cycle control mode, where PWM pulse width of the INx input pins have to be controlled. This allows for additional control of the current chopping scheme by the external controller.

Few scenarios of driving high-side and low-side loads are described below -

- **Resistive loads connected to ground:**

The regulated current will not exceed  $I_{TRIP}$ . If  $I_{TRIP}$  is higher than the  $(VM / R_{LOAD})$ , the load current is regulated at  $VM / R_{LOAD}$  level while  $INx = 1$  (shown in [Figure 7-3](#)).

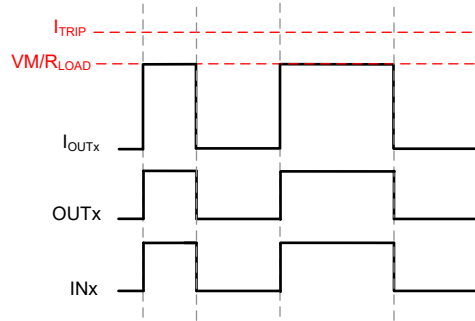
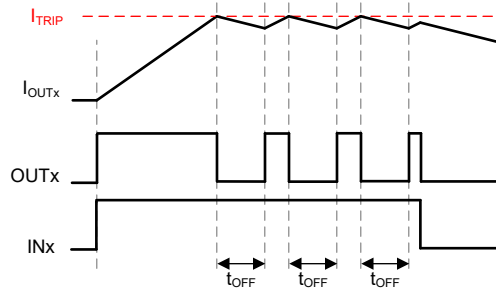

**Figure 7-3. Resistive Load Connected to ground, Cycle-by-cycle control**

• **Inductive loads connected to ground:**

It should be ensured that the current decays enough every cycle to prevent runaway and triggering overcurrent protection.

- For the scenario shown in [Figure 7-4](#), with  $INx = 1$ , the low-side MOSFET is turned on for  $t_{OFF}$  duration after  $I_{OUT}$  exceeds  $I_{TRIP}$ . After  $t_{OFF}$ , the high side MOSFET is again turned on till  $I_{OUT}$  exceeds  $I_{TRIP}$  again.



**Figure 7-4. Inductive Load Connected to ground, fixed off-time current chopping**

If, after the  $t_{OFF}$  time has elapsed the current is still higher than the  $I_{TRIP}$  level, the device enforces another  $t_{OFF}$  time period of the same duration. The OFF time extension will continue till sensed current is less than  $I_{TRIP}$  at the end of  $t_{OFF}$  time.

- Loads can also be controlled using the cycle-by-cycle method. When  $INx = 1$ , the current through the load builds up; and when  $INx = 0$ , the current through the load decays. By properly choosing the duty cycle of the  $INx$  pulse, current can be regulated to a target value. Various such scenarios are shown in [Figure 7-5](#) and [Figure 7-6](#).

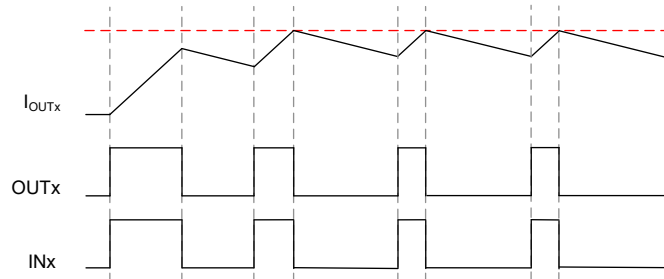

**Figure 7-5. Inductive Load Connected to ground, Cycle-by-cycle control**

The next scenario requires  $INx$  pin duty cycle adjustment ( $T$  has to be less than  $T_{OFF}$ ) to ensure that the current does not run away.

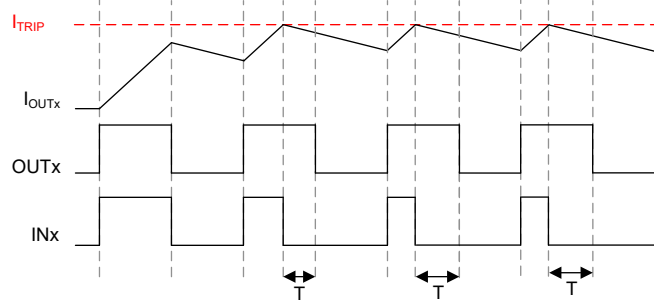

Figure 7-6. Inductive Load Connected to ground, Cycle-by-cycle control

- **Loads connected to VM:**

Such loads can be controlled by controlling the INx pin pulse width: INx = 0 builds up the current, and INx = 1 decays the current, as shown in Figure 7-7 and Figure 7-8.

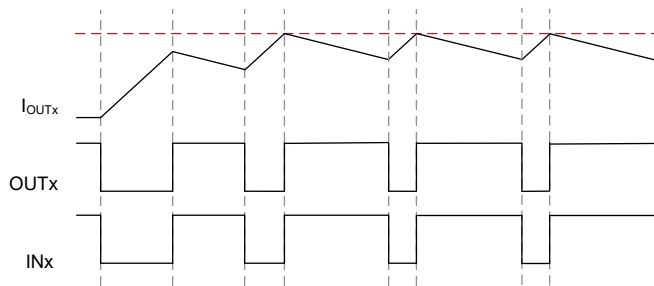

Figure 7-7. Inductive Load Connected to VM, Cycle-by-cycle control

This scenario requires INx pin duty cycle adjustment to ensure that the current does not run away.

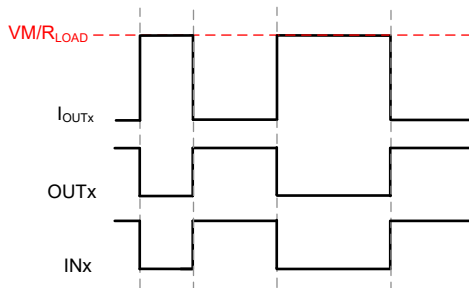

Figure 7-8. Resistive Load Connected to ground, Cycle-by-cycle control

## 7.6 Charge Pump

A charge pump is integrated to supply the high-side N-channel MOSFET gate-drive voltage. The charge pump requires a capacitor between the VM and VCP pins to act as the storage capacitor. Additionally a ceramic capacitor is required between the CPH and CPL pins to act as the flying capacitor.



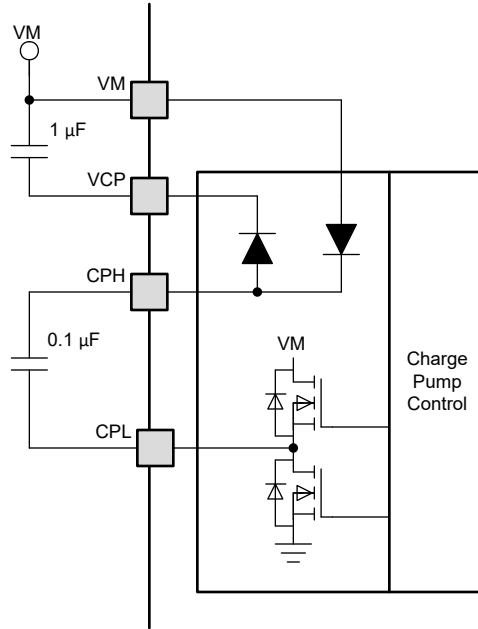

Figure 7-9. Charge Pump Block Diagram

## 7.7 Linear Voltage Regulator

A linear voltage regulator is integrated in the device. When the VCC pin is connected to DVDD, the DVDD regulator provides power to the low-side gate driver and all the internal circuits. For proper operation, bypass the DVDD pin to GND using a 1 μF ceramic capacitor. The DVDD output is nominally 5-V.

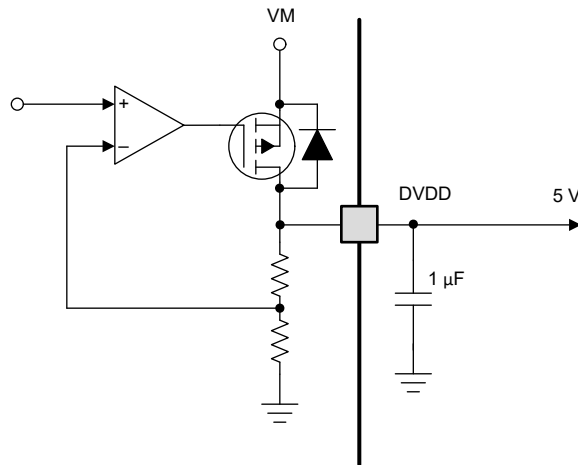

Figure 7-10. Linear Voltage Regulator Block Diagram

If a digital input must be tied permanently high, tying the input to the DVDD pin instead of an external regulator is preferred. This method saves power when the VM pin is not applied or in sleep mode: the DVDD regulator is disabled and current does not flow through the input pulldown resistors. For reference, logic level inputs have a typical pulldown of 200 kΩ.

The nSLEEP pin cannot be tied to DVDD, else the device will never exit sleep mode.

## 7.8 VCC Voltage Supply

An external voltage can be applied to the VCC pin to power the internal logic circuitry. The voltage on the VCC pin should be between 3.05 V and 5.5 V and should be well regulated. When an external supply is not available, VCC must be connected to the DVDD pin of the device.

When powered by the VCC, the internal logic blocks do not consume power from the VM supply rail - thereby reducing the power loss in the DRV8962. This is beneficial in high voltage applications, and when ambient temperature is high. Bypass the VCC pin to ground using a 0.1  $\mu\text{F}$  ceramic capacitor.

## 7.9 Logic Level Pin Diagram

The pin diagram below shows the input structure for INx, ENx, MODE, OCPM and nSLEEP pins.

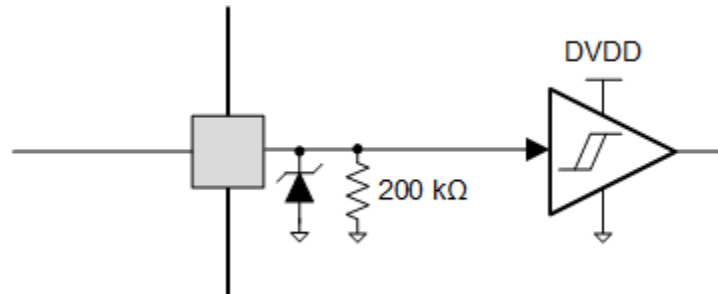

Figure 7-11. Logic-Level Input Pin Diagram

## 7.10 Protection Circuits

The device is fully protected against supply undervoltage, charge pump undervoltage, output overcurrent, and device overtemperature events.

### 7.10.1 VM Undervoltage Lockout (UVLO)

If at any time the voltage on the VM pin falls below the UVLO threshold voltage:

- All the outputs are disabled (High-Z)
- nFAULT pin is driven low
- The charge pump is disabled

Normal operation resumes (driver operation and nFAULT released) when the VM voltage recovers above the UVLO rising threshold voltage.

### 7.10.2 VCP Undervoltage Lockout (CPUV)

If at any time the voltage on the VCP pin falls below the CPUV voltage:

- All the outputs are disabled (High-Z)
- nFAULT pin is driven low
- The charge pump remains active

Normal operation resumes (driver operation and nFAULT released) when the VCP undervoltage condition is removed.

### 7.10.3 Logic Supply Power on Reset (POR)

If at any time the voltage on the VCC pin falls below the  $VCC_{UVLO}$  threshold:

- All the outputs are disabled (High-Z)
- Charge pump is disabled

VCC UVLO is not reported on the nFAULT pin. Normal motor-driver operation resumes when the VCC undervoltage condition is removed.

### 7.10.4 Overcurrent Protection (OCP)

Analog current-limit circuit on each MOSFET limits the current through that MOSFET by removing the gate drive. If this current limit persists for longer than the  $t_{OCP}$  time, an overcurrent fault is detected.

- Only the half-bridge experiencing the overcurrent will be disabled
- nFAULT is driven low

- Charge pump remains active

Overcurrent conditions on both high and low side MOSFETs; meaning a short to ground or short to supply will result in an overcurrent fault detection.

Once the overcurrent condition is removed, the recovery mechanism depends on the OCPM pin setting. OCPM pin programs either latch-off or automatic retry type recovery.

- When the OCPM pin is logic low, the device has latch-off type recovery - which means once the OCP condition is removed, normal operation resumes after applying an nSLEEP reset pulse or a power cycling.
- When the OCPM pin is logic high, normal operation resumes automatically (driver operation and nFAULT released) after the  $t_{RETRY}$  time has elapsed and the fault condition is removed.

### 7.10.5 Thermal Shutdown (OTSD)

Thermal shutdown is detected if the die temperature exceeds the thermal shutdown limit ( $T_{OTSD}$ ). When thermal shutdown is detected -

- All MOSFETs in the Half-bridges are disabled
- nFAULT is driven low
- Charge pump is disabled

Once the thermal shutdown condition is removed, the recovery mechanism depends on the OCPM pin setting. OCPM pin programs either latch-off or automatic retry type recovery.

- When the OCPM pin is logic low, the device has latch-off type recovery - which means after the junction temperature falls below the overtemperature threshold limit minus the hysteresis ( $T_{OTSD} - T_{HYS\_OTSD}$ ), normal operation resumes after applying an nSLEEP reset pulse or a power cycling.
- When the OCPM pin is logic high, normal operation resumes automatically after the junction temperature falls below the overtemperature threshold limit minus the hysteresis ( $T_{OTSD} - T_{HYS\_OTSD}$ ).

### 7.10.6 nFAULT Output

The nFAULT pin has an open-drain output and should be pulled up to a 5-V, 3.3-V or 1.8-V supply. When a fault is detected, the nFAULT pin will be logic low. nFAULT pin will be high after power-up. For a 5-V pullup, the nFAULT pin can be tied to the DVDD pin with a resistor. For a 3.3-V or 1.8-V pullup, an external supply must be used.

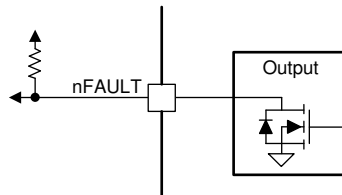

Figure 7-12. nFAULT Pin

### 7.10.7 Fault Condition Summary

Table 7-4. Fault Condition Summary

FAULT	CONDITION	ERROR REPORT	Half-BRIDGE	CHARGE PUMP	LOGIC	RECOVERY
VM undervoltage (UVLO)	$VM < V_{UVLO}$	nFAULT	Disabled	Disabled	Reset	$VM > V_{UVLO}$
VCP undervoltage (CPUV)	$VCP < V_{CPUV}$	nFAULT	Disabled	Operating	Operating	$VCP > V_{CPUV}$
Logic Supply POR	$VCC < VCC_{UVLO}$	-	Disabled	Disabled	Reset	$VCC > VCC_{UVLO}$
Overcurrent (OCP)	$I_{OUT} > I_{OCP}$ , OCPM = 0	nFAULT	Disabled	Operating	Operating	Latched: nSLEEP reset pulse
	$I_{OUT} > I_{OCP}$ , OCPM = 1	nFAULT	Disabled	Operating	Operating	Automatic retry: $t_{RETRY}$

**Table 7-4. Fault Condition Summary (continued)**

FAULT	CONDITION	ERROR REPORT	Half-BRIDGE	CHARGE PUMP	LOGIC	RECOVERY
Thermal Shutdown (OTSD)	$T_J > T_{TSD}$ , OCPM = 0	nFAULT	Disabled	Disabled	Operating	Latched: nSLEEP reset pulse
	$T_J > T_{TSD}$ , OCPM = 1	nFAULT	Disabled	Disabled	Operating	Automatic: $T_J < T_{OTSD} - T_{HYS\_OTSD}$

## 7.11 Device Functional Modes

### 7.11.1 Sleep Mode

When the nSLEEP pin is low, the device enters a low-power sleep mode. In sleep mode, all the internal MOSFETs, the DVDD regulator, SPI and the charge pump is disabled. The  $t_{SLEEP}$  time must elapse after a falling edge on the nSLEEP pin before the device enters sleep mode. The device is brought out of sleep automatically if the nSLEEP pin is brought high. The  $t_{WAKE}$  time must elapse before the device is ready for inputs.

### 7.11.2 Operating Mode

This mode is enabled when -

- nSLEEP is high
- $V_M > UVLO$

The  $t_{WAKE}$  time must elapse before the device is ready for inputs.

### 7.11.3 nSLEEP Reset Pulse

A latched fault can be cleared by an nSLEEP reset pulse. This pulse width must be greater than 20  $\mu s$  and smaller than 40  $\mu s$ . If nSLEEP is low for longer than 40  $\mu s$ , but less than 120  $\mu s$ , the faults are cleared and the device may or may not shutdown, as shown in the timing diagram below. This reset pulse does not affect the status of the charge pump or other functional blocks.

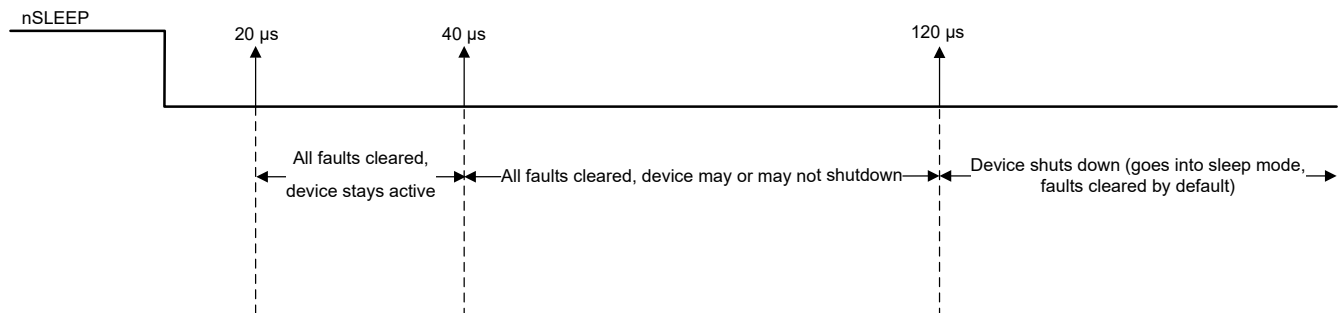

**Figure 7-13. nSLEEP Reset Pulse**

### 7.11.4 Functional Modes Summary

Table 7-5 lists a summary of the functional modes.

**Table 7-5. Functional Modes Summary**

	CONDITION	CONFIGURATION	Half-BRIDGE	DVDD Regulator	CHARGE PUMP	Logic
Sleep mode	$4.5 V < V_M < 65 V$	nSLEEP pin = 0	Disabled	Disabled	Disabled	Disabled
Operating	$4.5 V < V_M < 65 V$	nSLEEP pin = 1	Operating	Operating	Operating	Operating

## 8 Application and Implementation

### Note

Information in the following applications sections is not part of the TI component specification, and TI does not warrant its accuracy or completeness. TI's customers are responsible for determining suitability of components for their purposes, as well as validating and testing their design implementation to confirm system functionality.

### 8.1 Application Information

The DRV8962 can be used to drive the following types of loads -

- Up to four solenoid loads
- One stepper motor
- Two brushed-DC motors
- One 3-phase sinewave Brushless-DC motor
- One 3-phase Permanent magnet synchronous motor (PMSM)
- One or two thermoelectric coolers (TEC)

#### 8.1.1 Driving Solenoid Loads

The DRV8962 can drive four solenoid loads at the same time. For loads connected to ground, the IPROPI pins output the load current information; and the load current can be regulated to an  $I_{TRIP}$  level determined by the voltage on the VREF pin.

The DRV8962 supports independent IN and EN pins for each of the four half-bridges. All the four half-bridges also have separate PGND pins.

##### 8.1.1.1 Solenoid Driver Typical Application

Figure 8-1 shows a schematic of the DRV8962 driving four loads connected to ground.

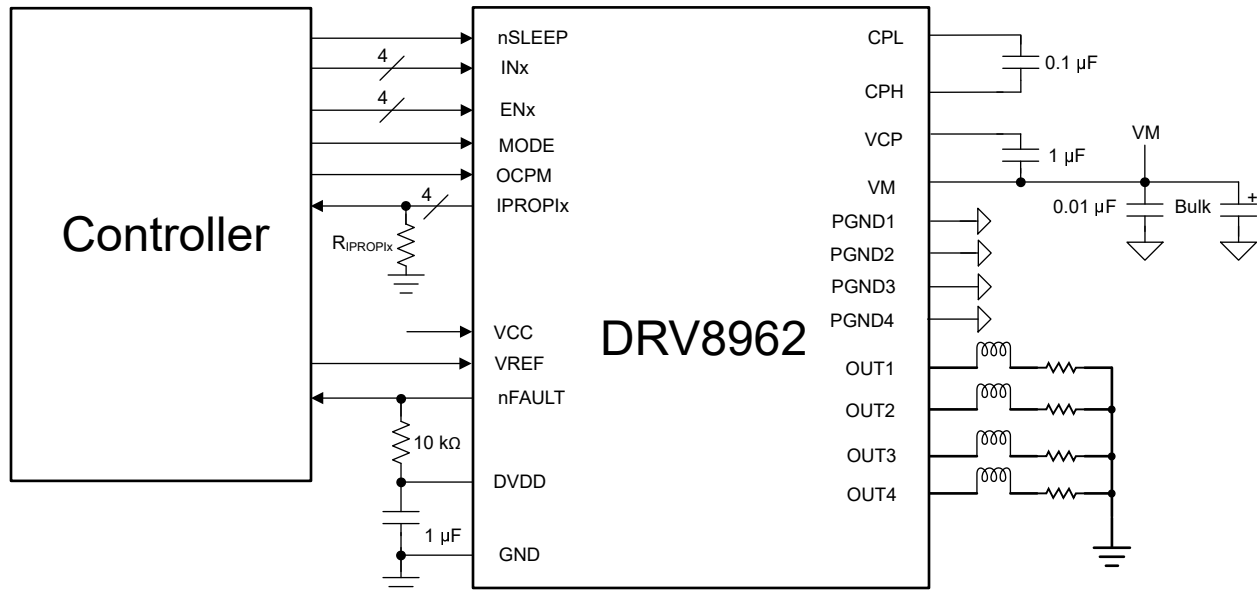

Figure 8-1. Driving Solenoids with DRV8962

##### 8.1.1.2 Thermal Calculations

The output current and power dissipation capabilities of the device are heavily dependent on the PCB design and external system conditions. This section provides some guidelines for calculating these values.

Total power dissipation for the device is composed of three main components. These are the power MOSFET  $R_{DS(ON)}$  (conduction) losses, the power MOSFET switching losses and the quiescent supply current dissipation. While other factors may contribute additional power losses, these other items are typically insignificant compared to the three main items.

#### 8.1.1.2.1 Power Loss Calculations

The total power dissipation in each half-bridge can be calculated as -

$$P_{HB} = P_{HS} + P_{LS} = [R_{DS(ON)} \times I_L^2] + [(2 \times V_D \times t_D) + (VM \times t_{RF})] \times I_L \times f_{PWM}$$

Where,

- $R_{DS(ON)}$  = ON resistance of each FET
  - For DRV8962, it is typically 50 mΩ at 25 °C, and 85 mΩ at 150 °C.
- $f_{PWM}$  = PWM switching frequency
- VM = Supply voltage to the driver
- $I_L$  = Load current
- D = PWM duty cycle (between 0 and 1)
- $t_{RF}$  = Output voltage rise/ fall time
  - For DRV8962, the rise/fall time is either 70 ns or 140 ns
- $V_D$  = FET body diode forward bias voltage
  - For DRV8962, it is 1 V
- $t_D$  = dead time
  - For DRV8962, it is 300 ns

So, total power dissipation in the DRV8962 is -

$$P_{TOT} = n \times P_{HB} + P_Q$$

Where n is the number of half-bridges switching at the same time, and  $P_Q$  is the quiescent power loss.

For this example, let us assume -

- All four half-bridges are switching
- VM = 24 V
- $I_L$  = 4 A
- Ambient temperature ( $T_A$ ) = 25 °C
- $t_{RF}$  = 70 ns
- Input PWM frequency = 20 kHz

When the VCC pin is connected to an external power supply, the quiescent current is 4 mA, and therefore  $P_Q$  will be (24 V x 4 mA) = 96 mW.

$$P_{HB} = [50 \text{ m}\Omega \times 4^2] + [(2 \times 1 \text{ V} \times 300 \text{ ns}) + (24 \text{ V} \times 70 \text{ ns})] \times 4 \text{ A} \times 20 \text{ KHz} = 0.982 \text{ W}$$

$$P_{TOT} = (4 \times 0.982) + 0.096 = 4.024 \text{ W}$$

#### 8.1.1.2.2 Junction Temperature Estimation

The estimated junction temperature will be:  $T_J = T_A + (P_{TOT} \times \theta_{JA})$

The junction-to-ambient thermal resistance  $\theta_{JA}$  is 22.2 °C/W for the DDW package on a JEDEC standard PCB, and close to 5 °C/W for the DDV package if a suitable heat sink is used.

Therefore, the first estimate of the junction temperature is -

$$T_J = T_A + (P_{TOT} \times \theta_{JA}) = 25 + (4.024 \times 22.2) = 114.3 \text{ °C}$$

For more accurate calculation, consider the dependency of on-resistance of FETs with device junction temperature shown in the Typical Operating Characteristics section.

For example,

- At 114.3 °C junction temperature, the on-resistance will likely increase by a factor of 1.35 compared to the on-resistance at 25 °C.
- The initial estimate of conduction loss (loss due to  $R_{DS(ON)}$ ) for each half-bridge was 0.8 W.
- New estimate of conduction loss will therefore be  $0.8\text{ W} \times 1.35 = 1.08\text{ W}$ .
- New estimate of the total power loss will accordingly be 5.144 W.
- New estimate of junction temperature for the DDW package will be 139.2 °C.
- Further iterations are unlikely to increase the junction temperature estimate by significant amount.

The following plot estimates the current that can be delivered from each output of the DDW package as a function of the ambient temperature and the number of half-bridges (N) switching at any time, with the following assumptions:

- $V_M = 24\text{ V}$
- $t_{RF} = 70\text{ ns}$
- $f_{PWM} = 20\text{ kHz}$
- $T_J = 150\text{ °C}$

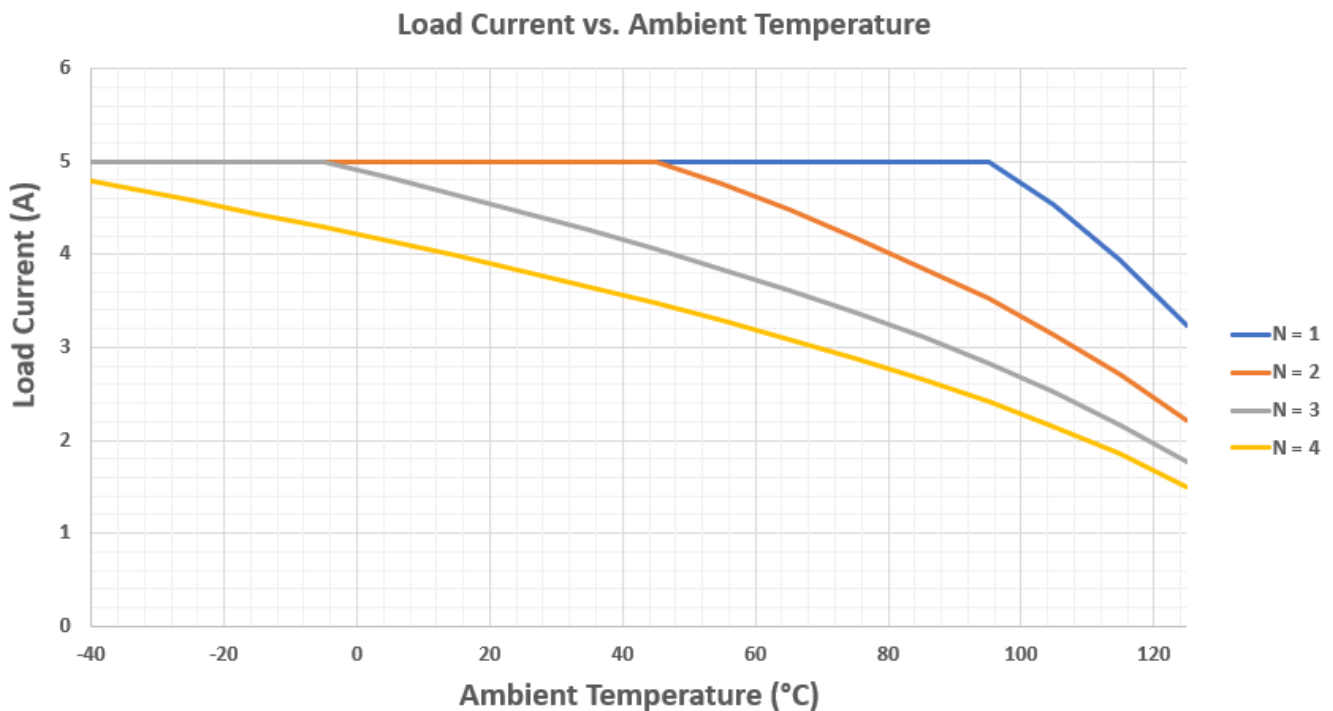

**Figure 8-2. Load Current per Half-bridge vs. Ambient Temperature**

### 8.1.2 Driving Stepper Motors

The DRV8962 can drive one stepper motor using the PWM input interface.

#### 8.1.2.1 Stepper Driver Typical Application

The following schematic shows the DRV8962 driving a stepper motor.

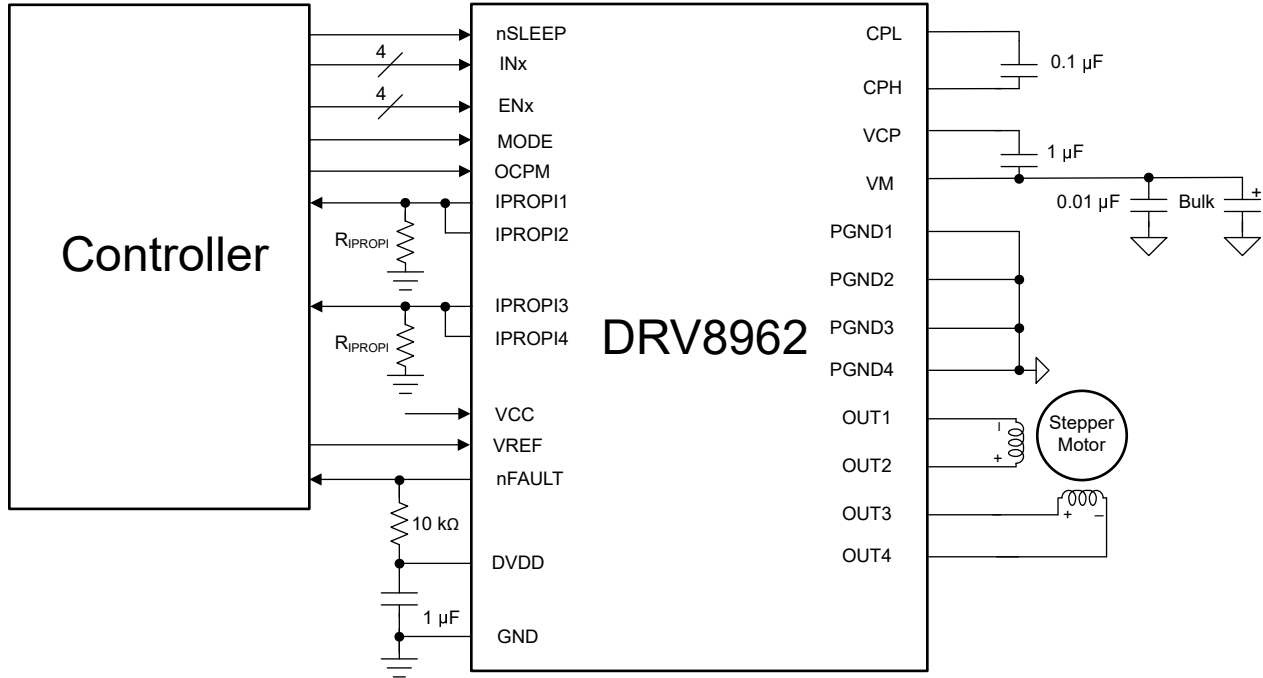

**Figure 8-3. Driving Stepper Motor with DRV8962**

The full-scale current ( $I_{FS}$ ) is the maximum current driven through either winding. This quantity will depend on the VREF voltage and the resistor connected from IPROPI pin to ground.

$$I_{FS} \times A_{IPROPI} = V_{VREF} / R_{IPROPI}$$

The maximum allowable voltage on the VREF pins is 3.3 V. DVDD can be used to provide VREF through a resistor divider.

**Note**

The  $I_{FS}$  current must also follow Equation 4 to avoid saturating the motor. VM is the motor supply voltage, and  $R_L$  is the motor winding resistance.

$$I_{FS} \text{ (A)} < \frac{VM \text{ (V)}}{R_L \text{ (}\Omega\text{)} + 2 \times R_{DS(ON)} \text{ (}\Omega\text{)}} \quad (4)$$

If the target motor speed is too high, the motor will not spin. Make sure that the motor can support the target speed.

For a desired motor speed ( $v$ ), microstepping level ( $n_m$ ), and motor full step angle ( $\theta_{step}$ ), determine the frequency of the input waveform as follows -

$$f_{step} \text{ (steps / s)} = \frac{v \text{ (rpm)} \times 360 \text{ (}^\circ\text{ / rot)}}{\theta_{step} \text{ (}^\circ\text{ / step)} \times n_m \text{ (steps / microstep)} \times 60 \text{ (s / min)}} \quad (5)$$

$\theta_{step}$  can be found in the stepper motor data sheet or written on the motor itself.

The frequency  $f_{step}$  gives the frequency of input change on the DRV8962.  $1 / f_{step} = t_{STEP}$  on the diagram below. Equation 6 shows an example calculation for a 120 rpm target speed and 1/2 step.

$$f_{step} \text{ (steps / s)} = \frac{120 \text{ rpm} \times 360^\circ / \text{rot}}{1.8^\circ / \text{step} \times 1/2 \text{ steps / microstep} \times 60 \text{ s / min}} = 800\text{Hz} \quad (6)$$



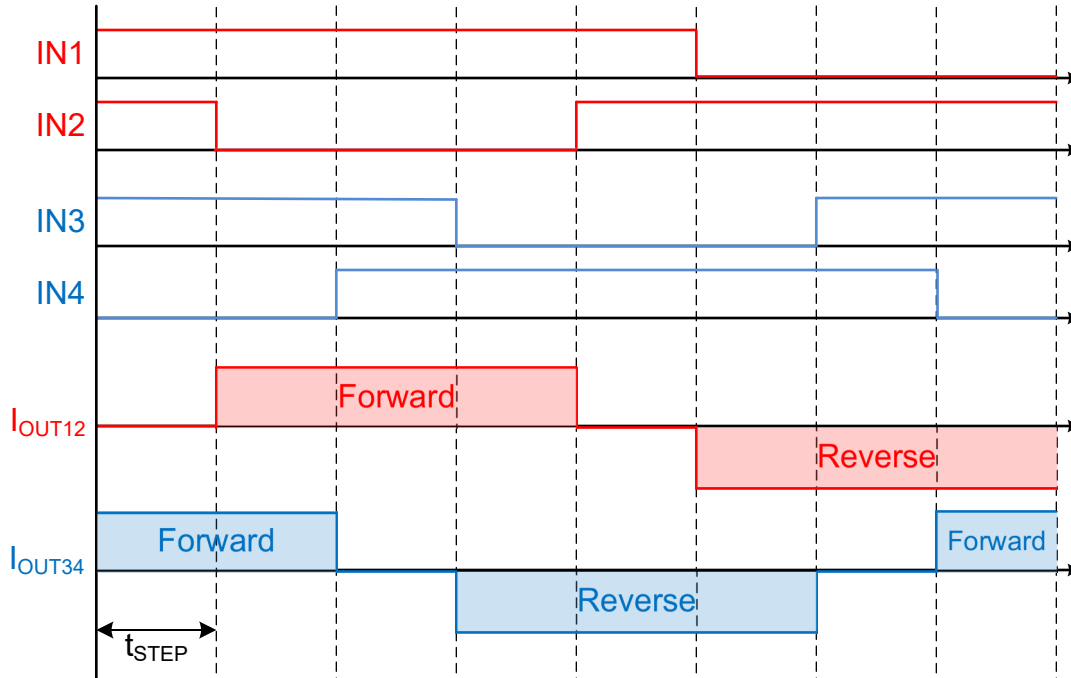

Figure 8-4. Example 1/2 Stepping Operation

Connect the IPROPI outputs corresponding to the same H-bridge together. IPROPI1 and IPROPI2, when connected together, represent the current of coil A of the stepper (connected between OUT1 and OUT2) during drive and slow-decay (high-side recirculation) modes. Similarly, IPROPI3 and IPROPI4, connected together, will represent coil B current.

When two IPROPI pins are connected together, the effective current mirror gain will be 424  $\mu$ A/A typical. The resistor from the combined IPROPI pin to ground should be selected accordingly.

### 8.1.2.2 Power Loss Calculations

The following calculations assume a use case where the supply voltage is 24 V, full-scale current is 5 A, rise/fall time is 140 ns and input PWM frequency is 30-kHz.

The total power dissipation constitutes of three main components - conduction loss ( $P_{COND}$ ), switching loss ( $P_{SW}$ ) and power loss due to quiescent current consumption ( $P_Q$ ).

The conduction loss ( $P_{COND}$ ) depends on the motor rms current ( $I_{RMS}$ ) and high-side ( $R_{DS(ONH)}$ ) and low-side ( $R_{DS(ONL)}$ ) on-state resistances as shown in Equation 7.

$$P_{COND} = 2 \times (I_{RMS})^2 \times (R_{DS(ONH)} + R_{DS(ONL)}) \quad (7)$$

The conduction loss for the typical application shown in Section 8.1.2.1 is calculated in Equation 8.

$$P_{COND} = 2 \times (I_{RMS})^2 \times (R_{DS(ONH)} + R_{DS(ONL)}) = 2 \times (5-A / \sqrt{2})^2 \times (0.1-\Omega) = 2.5-W \quad (8)$$

The power loss due to the PWM switching frequency depends on the output voltage rise/fall time ( $t_{RF}$ ), supply voltage, motor RMS current and the PWM switching frequency. The switching losses in each H-bridge during rise-time and fall-time are calculated as shown in Equation 9 and Equation 10.

$$P_{SW\_RISE} = 0.5 \times V_{VM} \times I_{RMS} \times t_{RF} \times f_{PWM} \quad (9)$$

$$P_{SW\_FALL} = 0.5 \times V_{VM} \times I_{RMS} \times t_{RF} \times f_{PWM} \quad (10)$$

After substituting the values of various parameters, the switching losses in each H-bridge are calculated as shown below -

$$P_{SW\_RISE} = 0.5 \times 24\text{-V} \times (5\text{-A} / \sqrt{2}) \times (140 \text{ ns}) \times 30\text{-kHz} = 0.178\text{-W} \quad (11)$$

$$P_{SW\_FALL} = 0.5 \times 24\text{-V} \times (5\text{-A} / \sqrt{2}) \times (100 \text{ ns}) \times 30\text{-kHz} = 0.178\text{-W} \quad (12)$$

The total switching loss for the stepper motor driver ( $P_{SW}$ ) is calculated as twice the sum of rise-time ( $P_{SW\_RISE}$ ) switching loss and fall-time ( $P_{SW\_FALL}$ ) switching loss as shown below -

$$P_{SW} = 2 \times (P_{SW\_RISE} + P_{SW\_FALL}) = 2 \times (0.178\text{-W} + 0.178\text{-W}) = 0.712\text{-W} \quad (13)$$

---

#### Note

The output rise/fall time ( $t_{RF}$ ) is expected to change based on the supply-voltage, temperature and device to device variation.

---

When the VCC pin is connected to an external voltage, the quiescent current is typically 4 mA. The power dissipation due to the quiescent current consumed by the power supply is calculated as shown below -

$$P_Q = V_{VM} \times I_{VM} \quad (14)$$

Substituting the values, quiescent power loss can be calculated as shown below -

$$P_Q = 24\text{-V} \times 4\text{-mA} = 0.096\text{-W} \quad (15)$$

---

#### Note

The quiescent power loss is calculated using the typical operating supply current ( $I_{VM}$ ) which is dependent on supply-voltage, temperature and device to device variations.

---

The total power dissipation ( $P_{TOT}$ ) is calculated as the sum of conduction loss, switching loss and the quiescent power loss as shown in [Equation 16](#).

$$P_{TOT} = P_{COND} + P_{SW} + P_Q = 2.5\text{-W} + 0.712\text{-W} + 0.096\text{-W} = 3.308\text{-W} \quad (16)$$

### 8.1.2.3 Junction Temperature Estimation

For an ambient temperature of  $T_A$  and total power dissipation ( $P_{TOT}$ ), the junction temperature ( $T_J$ ) is calculated as -

$$T_J = T_A + (P_{TOT} \times R_{\theta JA})$$

Considering a JEDEC standard 4-layer PCB, the junction-to-ambient thermal resistance ( $R_{\theta JA}$ ) is 22.2 °C/W for the DDW package.

Assuming 25°C ambient temperature, the junction temperature for the DDW package is calculated as shown below -

$$T_J = 25^\circ\text{C} + (3.308\text{-W} \times 22.2 \text{ }^\circ\text{C/W}) = 98.4 \text{ }^\circ\text{C} \quad (17)$$

For more accurate calculation, consider the dependency of on-resistance of FETs with device junction temperature shown in the Typical Operating Characteristics section.

For example,

- At 98.4 °C junction temperature, the on-resistance will likely increase by a factor of 1.25 compared to the on-resistance at 25 °C.
- The initial estimate of conduction loss was 2.5 W.
- New estimate of conduction loss will therefore be 2.5 W x 1.25 = 3.125 W.
- New estimate of the total power loss will accordingly be 3.933 W.
- New estimate of junction temperature for the DDW package will be 112.3 °C.

- Further iterations are unlikely to increase the junction temperature estimate by significant amount.

When using the DDV package, if a heat sink with less than 4 °C/W thermal resistance is chosen, the junction to ambient thermal resistance can be lower than 5 °C/W. The initial estimate of the junction temperature with the DDV package in this application will therefore be -

$$T_J = 25^{\circ}\text{C} + (3.308\text{-W} \times 5^{\circ}\text{C/W}) = 41.5^{\circ}\text{C} \quad (18)$$

As the DDV package results in low thermal resistance, it can deliver 10 A full-scale current.

### 8.1.3 Driving Brushed-DC Motors

The DRV8962 can be used to drive one or two brushed-DC motors.

#### 8.1.3.1 Brushed-DC Driver Typical Application

The schematic below shows the DRV8962 driving two brushed-DC motors.

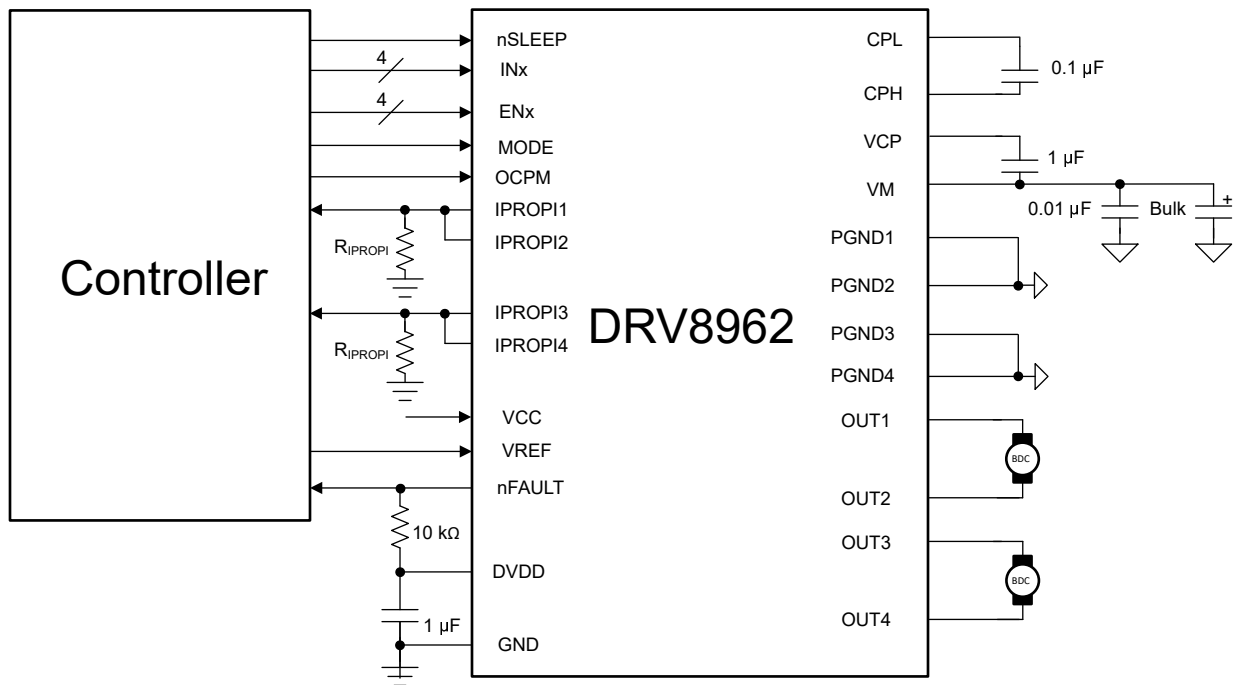

Figure 8-5. Driving two Brushed-DC Motors with DRV8962

The following truth table describes how to control brushed-DC motors -

Table 8-1. Brushed-DC Motor Truth Table

Function	EN1	EN2	IN1	IN2	OUT1	OUT2
Forward	1	1	1	PWM	H	H/L
Reverse	1	1	PWM	1	H/L	H
Brake	1	1	1	1	H	H
Brake*	1	1	0	0	L	L
Coast*	0	X	X	X	Z	X
Coast*	X	0	X	X	X	Z

\* IPROPI pins will not output proportional current in these conditions.

### 8.1.3.2 Power Loss Calculation

For a H-bridge with high-side recirculation, power dissipation for each FET can be approximated as follows:

- $P_{HS1} = R_{DS(ON)} \times I_L^2$
- $P_{LS1} = 0$
- $P_{HS2} = [R_{DS(ON)} \times I_L^2 \times (1-D)] + [2 \times V_D \times I_L \times t_D \times f_{PWM}]$
- $P_{LS2} = [R_{DS(ON)} \times I_L^2 \times D] + [VM \times I_L \times t_{RF} \times f_{PWM}]$

For estimating power dissipation for load current flow in the reverse direction, identical equations apply, with only swapping of HS1 with HS2 and LS1 with LS2.

Substituting the following values in the equations above -

- $VM = 24 \text{ V}$
- $I_L = 4 \text{ A}$
- $R_{DS(ON)} = 50 \text{ m}\Omega$
- $D = 0.5$
- $V_D = 1 \text{ V}$
- $t_D = 300 \text{ ns}$
- $t_{RF} = 70 \text{ ns}$
- $f_{PWM} = 20 \text{ kHz}$

The losses in each FET can be calculated as follows -

$$P_{HS1} = 50 \text{ m}\Omega \times 4^2 = 0.8 \text{ W}$$

$$P_{LS1} = 0$$

$$P_{HS2} = [50 \text{ m}\Omega \times 4^2 \times (1-0.5)] + [2 \times 1 \text{ V} \times 4 \text{ A} \times 300 \text{ ns} \times 20 \text{ kHz}] = 0.448 \text{ W}$$

$$P_{LS2} = [50 \text{ m}\Omega \times 4^2 \times 0.5] + [24 \times 4 \text{ A} \times 70 \text{ ns} \times 20 \text{ kHz}] = 0.534 \text{ W}$$

$$\text{Quiescent Current Loss } P_Q = 24 \text{ V} \times 4 \text{ mA} = 0.096 \text{ W}$$

$$P_{TOT} = 2 \times (P_{HS1} + P_{LS1} + P_{HS2} + P_{LS2}) + P_Q = 2 \times (0.8 + 0 + 0.448 + 0.534) + 0.096 = 3.66 \text{ W}$$

### 8.1.3.3 Junction Temperature Estimation

For an ambient temperature of  $T_A$  and total power dissipation ( $P_{TOT}$ ), the junction temperature ( $T_J$ ) is calculated as -

$$T_J = T_A + (P_{TOT} \times R_{\theta JA})$$

Considering a JEDEC standard 4-layer PCB, the junction-to-ambient thermal resistance ( $R_{\theta JA}$ ) is 22.2 °C/W for the DDW package.

Assuming 25°C ambient temperature, the junction temperature for the DDW package is calculated as shown below -

$$T_J = 25^\circ\text{C} + (3.66\text{-W} \times 22.2 \text{ }^\circ\text{C/W}) = 106.3 \text{ }^\circ\text{C} \tag{19}$$

For more accurate calculation, consider the dependency of on-resistance of FETs with device junction temperature, as explained in [Section 8.1.1.2.2](#) and [Section 8.1.2.3](#).

The DDV package with heat sink mounted on top will be able to deliver up to 10A current to both brushed-DC motors.

### 8.1.3.4 Driving Single Brushed-DC Motor

The outputs of DRV8962 can be connected in parallel to increase the drive current. [Figure 8-6](#) shows the schematic of DRV8962 driving a single brushed-DC motor.

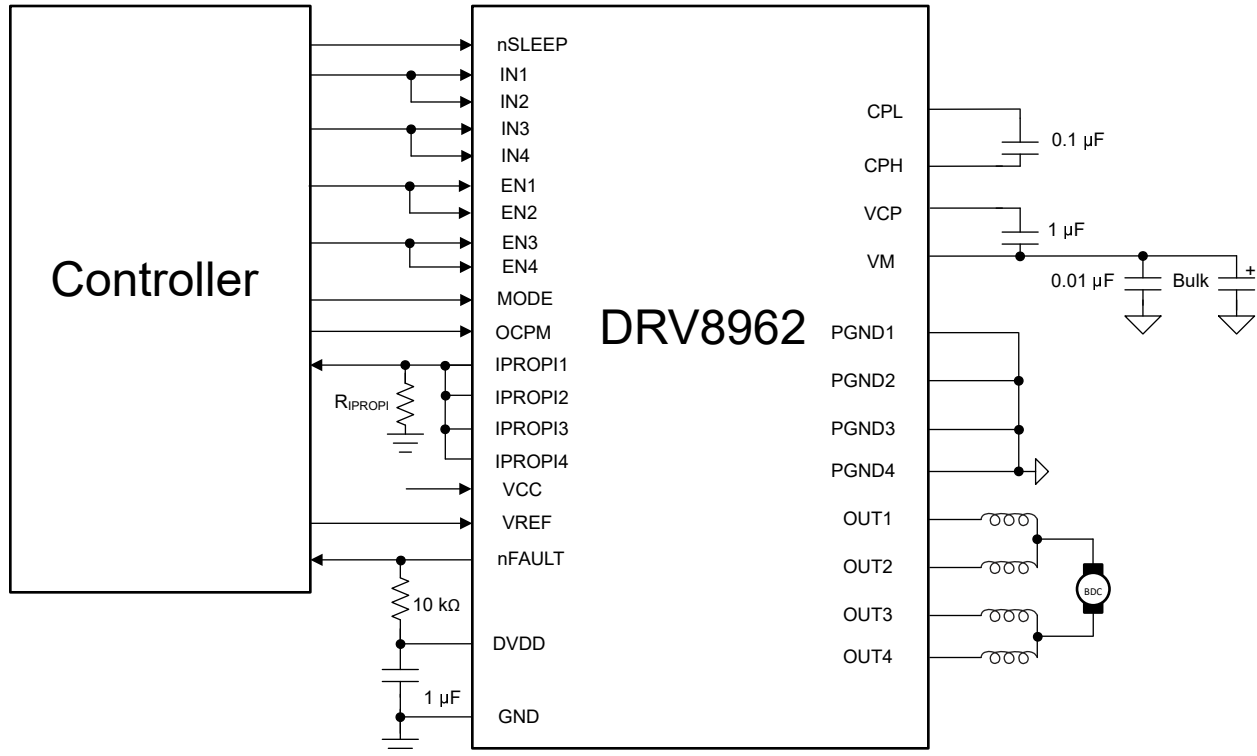

Figure 8-6. Driving Single Brushed-DC motor with DRV8962

In this mode, a minimum of 30 nH to 100 nH inductance or a ferrite bead is required after the output pins before connecting the two channels together. This will help to prevent any shoot through between two paralleled channels during switching transient due to mismatch of paralleled channels (for example, asymmetric PCB layout, etc).

#### 8.1.4 Driving Thermoelectric Coolers (TEC)

Thermoelectric coolers (TEC) work according to the Peltier effect. When a voltage is applied across the TEC, a DC current flows through the junction of the semiconductors, causing a temperature difference. Heat is transferred from one side of the TEC to the other. This creates a “hot” and a “cold” side of the TEC element. If the DC current is reversed, the hot and cold sides reverse as well.

A common way of modulating the current through the TEC is to use PWM driving and make the average current change by varying the ON and OFF duty cycles. To allow both heating and cooling from a single supply, a H-bridge topology is required. The DRV8962 can drive two H-bridges to drive two TECs bi-directionally with up to 5-A current. Pair of half-bridges can also be paralleled together to drive a single TEC with up to 10-A current.

The DRV8962 also features integrated current sensing and current sense output (IPROPI) with  $\pm 4\%$  accuracy to eliminate the need for two external shunt resistors in a closed-loop control topology, saving bill-of-materials cost and space. [Figure 8-7](#) shows the schematic of two TECs connected to a DRV8962 driver.

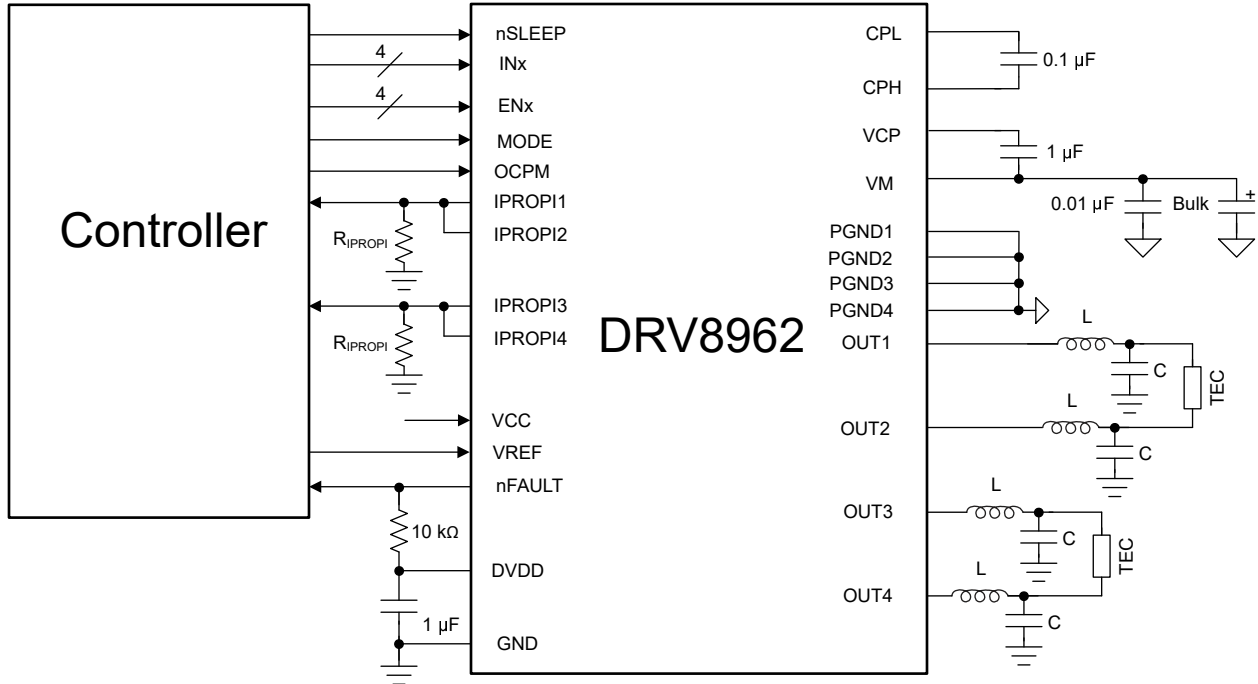

**Figure 8-7. Driving two TECs**

Figure 8-8 shows the schematic to drive one TEC with higher current.

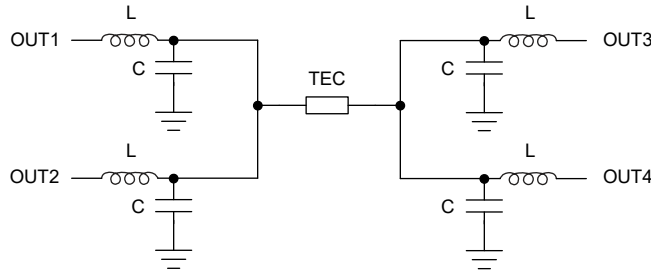

**Figure 8-8. Driving one TEC with higher current**

The LC filters connected to the output nodes convert the PWM output from the DRV8962 into a low-ripple DC voltage across the TEC. The filters are required to minimize the ripple current, because fast transients (e.g., square wave power) can shorten the life of the TEC. The maximum ripple current is recommended to be less than 10% of maximum current. The maximum temperature differential across the TEC, which decreases as ripple current increases, is calculated with the following equation:

$$\Delta T = \Delta T_{MAX} / (1 + N^2) \tag{20}$$

Where  $\Delta T$  is actual temperature differential,  $\Delta T_{MAX}$  is maximum possible temperature differential specified in the TEC datasheet,  $N$  is the ratio between ripple and maximum current.  $N$  should not be greater than 0.1.

The choice of the input PWM frequency is a trade-off between switching loss and use of smaller inductors and capacitors. High PWM frequency also means that the voltage across the TEC can be tightly controlled, and the LC components can potentially be cheaper.

The transfer function of a second order low-pass filter is shown in :

$$H(j\omega) = 1 / (1 - (\omega / \omega_0)^2 + j\omega / Q\omega_0) \tag{21}$$

Where,

$\omega_0 = 1 / \sqrt{LC}$ , resonant frequency of the filter

Q = quality factor

$\omega$  = DRV8962 input PWM frequency

The resonant frequency for the filter is typically chosen to be at least one order of magnitude lower than the PWM frequency. With this assumption, [Equation 20](#) may be simplified to -

H in dB =  $-40 \log (f_S/f_0)$

Where  $f_0 = 1 / 2\pi\sqrt{LC}$  and  $f_S$  is the input PWM switching frequency.

- If  $L = 10 \mu\text{H}$  and  $C = 22 \mu\text{F}$ , the resonant frequency is 10.7 kHz.
- This resonant frequency corresponds to 39 dB of attenuation at 100 kHz switching frequency.
- For  $V_M = 48 \text{ V}$ , 39 dB attenuation means that the amount of ripple voltage across the TEC element will be approximately 550 mV.
- For a TEC element with a resistance of  $1.5 \Omega$ , the ripple current through the TEC will therefore be 366 mA.
- At the 5-A maximum output current of the DRV8962, 366 mA corresponds to 7.32% ripple current.
- This will cause about 0.5% reduction of the maximum temperature differential of the TEC element, as per [Equation 20](#).

Adjust the LC values according to the supply voltage and DC current through the TEC element. The DRV8962 supports up to 200 kHz input PWM frequency. The power loss in the device at any given ambient temperature must be carefully considered before selecting the input PWM frequency.

Closing the loop on current is important in some TEC based heating and cooling systems. The DRV8962 can achieve this without the need for external current shunt resistors. Internal current mirrors are used to monitor the currents in each half-bridge and this information is available on IPROPI pins. A microcontroller can monitor and adjust the PWM duty based on the IPROPI pin voltage. When driving two TECs, connect the IPROPI pins of the corresponding half-bridges together to measure the H-bridge current. For example, for the schematic shown in [Figure 8-7](#), IPROPI1 and IPROPI2 are tied together, and IPROPI3 and IPROPI4 are also together. When driving only one TEC as shown in [Figure 8-8](#), tie all the IPROPI pins together.

Additionally, the DRV8962 can regulate the current internally by providing an external voltage reference (VREF) to the device to adjust the current regulation trip point. The current loop would then be closed within the H-bridge itself.

### 8.1.5 Driving Brushless DC Motors

The DRV8962 can also be used to drive a three-phase brushless DC (BLDC) motor. The DRV8962 supports independent control of three phases required to drive the BLDC motor. One of the four half-bridges of the DRV8962 can be disabled while driving a BLDC motor, by connecting the corresponding EN pin to ground. Shows a schematic of the DRV8962 driving a BLDC motor.

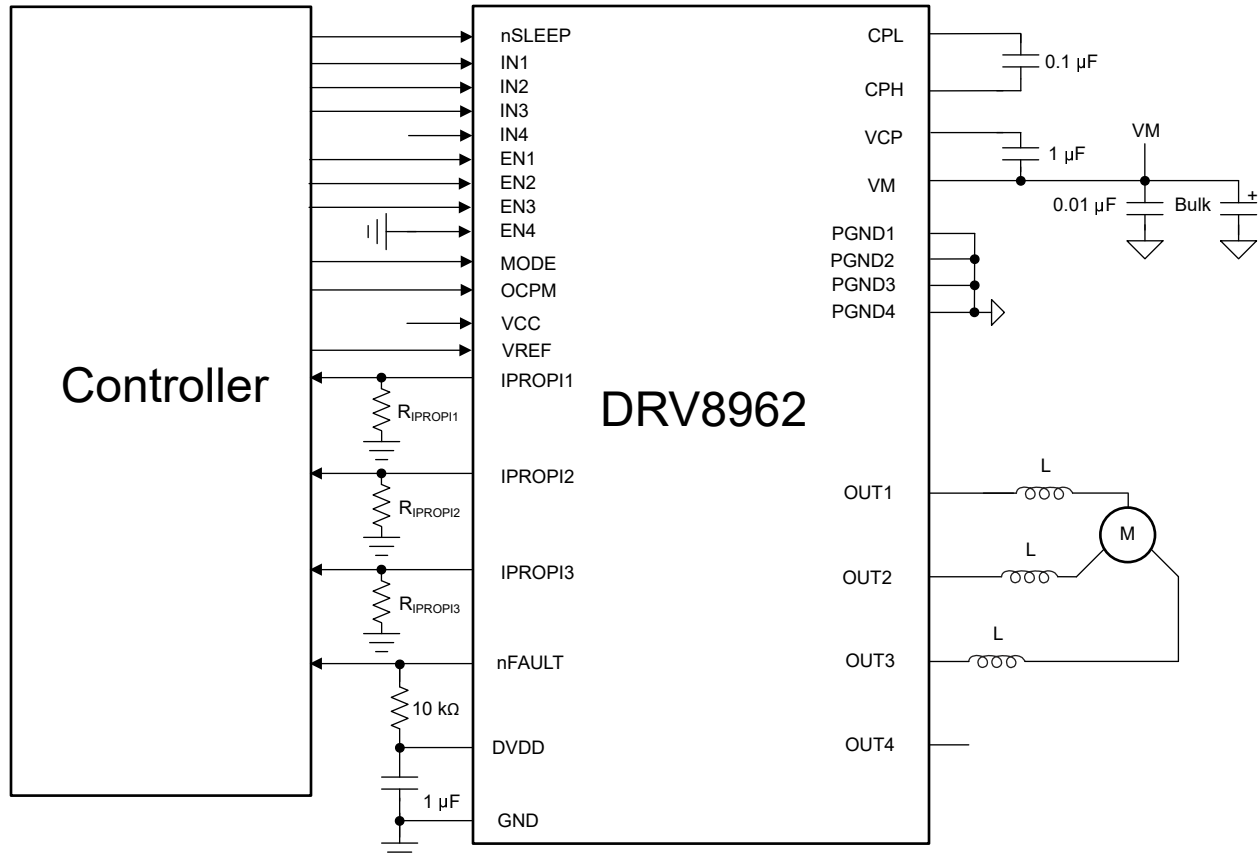

**Figure 8-9. Driving BLDC Motor with DRV8962**

The three half-bridges required to drive a BLDC motor can be controlled by six inputs - EN1, EN2, EN3 and IN1, IN2, IN3.

- When EN1 is low, OUT1 becomes high-impedance, allowing current to flow through the internal body diodes of the high-side and low-side FETs.
- When EN1 is high and IN1 is low, OUT1 is driven low with its low-side FET enabled.
- When EN1 is high and IN1 is high, OUT1 is driven high with its high-side FET enabled.
- Likewise is true for OUT2 and OUT3.
- EN4 can be grounded to permanently disable OUT4.

A minimum of 30 nH to 100 nH inductance or a ferrite bead has to be connected after the output pins. This will help to prevent any shoot through due to mismatch between channels (for example, process variation, unsymmetrical PCB layout, etc).

The IPROPI pins output a current proportional to the current flowing through the high-side FET of each half-bridge. The IPROPI output accuracy at maximum rated current is  $\pm 4\%$ .

$$I_{\text{PROPI}} = I_{\text{HS}} \times A_{\text{IPROPI}}$$

Each IPROPI pin should be connected to an external resistor ( $R_{\text{IPROPI}}$ ) to ground in order to generate a proportional voltage ( $V_{\text{IPROPI}}$ ) on the IPROPI pin. This allows for the load current to be measured as the voltage drop across the  $R_{\text{IPROPI}}$  resistor with a standard analog to digital converter (ADC).

$$V_{\text{IPROPI}} = I_{\text{PROPI}} \times R_{\text{IPROPI}}$$

If higher accuracy of current sensing is required, external sense resistors can be placed between the PGND pins and system ground. The voltage drop across the external sense resistor should not exceed 300 mV.



## 9 Package Thermal Considerations

### 9.1 DDW Package

Thermal pad of the DDW package is attached at bottom of device to improve the thermal capability of the device. The thermal pad has to be soldered with a very good coverage on PCB to deliver the power specified in the data sheet. Refer to the [Section 11.1](#) section for more details.

### 9.2 DDV Package

The DDV package is designed to interface directly to a heat sink using a thermal interface compound in between, (e.g., Ceramique from Arctic Silver, TIMTronics 413, etc.). The heat sink absorbs heat from the DRV8962 and transfers it to the air. With proper thermal management this process can reach equilibrium and heat can be continually transferred from the device. A concept digram of the heatsink on top of the DDV package is shown in [Figure 9-1](#).

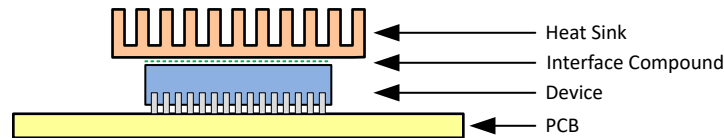

**Figure 9-1. Heat sink on DDV Package**

Care must be taken when mounting the heatsinks, ensuring good contact with thermal pads and not exceeding the mechanical stress capability of the parts to avoid breakage. The DDV package is capable of tolerating up to 90 Newton load. In production, it is recommended to apply less than 45 Newton load torque.

$R_{\theta JA}$  is a system thermal resistance from junction to ambient air. As such, it is a system parameter with the following components:

- $R_{\theta JC}$  of the DDV Package (thermal resistance from junction to exposed pad)
- Thermal resistance of the thermal interface material
- Thermal resistance of the heat sink

$$R_{\theta JA} = R_{\theta JC} + \text{thermal interface resistance} + \text{heat sink resistance}$$

The thermal resistance of the thermal interface material can be determined from the area of the exposed metal package and manufacturer's value for the area thermal resistance (expressed in  $^{\circ}\text{Cmm}^2/\text{W}$ ). For example, a typical white thermal grease with a 0.0254 mm (0.001 inch) thick layer has 4.52  $^{\circ}\text{Cmm}^2/\text{W}$  thermal resistance. The DDV package has an exposed area of 28.7  $\text{mm}^2$ . By dividing the area thermal resistance by the exposed metal area determines the thermal resistance for the interface material as 0.157 $^{\circ}\text{C}/\text{W}$ .

Heat sink thermal resistance is predicted by the heat sink vendor, modeled using a continuous flow dynamics (CFD) model, or measured. The following are the various important parameters in selecting a heatsink.

1. Thermal resistance
2. Airflow
3. Volumetric resistance
4. Fin density
5. Fin spacing
6. Width
7. Length

The thermal resistance is one parameter that changes dynamically depending on the airflow available.

Airflow is typically measured in LFM (linear feet per minute) or CFM (cubic feet per minute). LFM is a measure of velocity, whereas CFM is a measure of volume. Typically, fan manufacturers use CFM because fans are rated according to the quantity of air it can move. Velocity is more meaningful for heat removal at the board level, which is why the derating curves provided by most power converter manufacturers use this.

Typically, airflow is either classified as natural or forced convection.

- Natural convection is a condition with no external induced flow and heat transfer depends on the air surrounding the heatsink. The effect of radiation heat transfer is very important in natural convection, as it can be responsible for approximately 25% of the total heat dissipation. Unless the component is facing a hotter surface nearby, it is imperative to have the heatsink surfaces painted to enhance radiation.
- Forced convection occurs when the flow of air is induced by mechanical means, usually a fan or blower.

Limited thermal budget and space make the choice of a particular type of heatsink very important. This is where the volume of the heatsink becomes relevant. The volume of a heatsink for a given flow condition can be obtained by using the following equation:

$$\text{Volume}_{(\text{heatsink})} = \text{volumetric resistance (Cm}^3 \text{ }^\circ\text{C/W)} / \text{thermal resistance } \theta_{\text{SA}} \text{ (}^\circ\text{C/W)}$$

An approximate range of volumetric resistance is given in the following table:

Available Airflow (LFM)	Volumetric Resistance (Cm <sup>3</sup> °C/W)
NC	500 – 800
200	150 - 250
500	80 - 150
1000	50 - 80

The next important criterion for the performance of a heatsink is the width. It is linearly proportional to the performance of the heatsink in the direction perpendicular to the airflow. An increase in the width of a heatsink by a factor of two, three, or four increase the heat dissipation capability by a factor of two, three, or four. Similarly, the square root of the fin length used is approximately proportional to the performance of the heatsink in the direction parallel to the airflow. In case of an increase in the length of the heatsink by a factor of two, three, or four only increases the heat dissipation capability by a factor of 1.4, 1.7, or 2.

If the board has sufficient space, it is always beneficial to increase the width of a heatsink rather than the length of the heatsink. This is only the beginning of an iterative process before the correct and the actual heatsink design is achieved.

The heat sink must be supported mechanically at each end of the IC. This mounting ensures the correct pressure to provide good mechanical, thermal and electrical contact. The heat sink should be connected to GND or left floating.

### 9.3 PCB Material Recommendation

FR-4 Glass Epoxy material with 2 oz. (70 μm) copper on both top and bottom layer is recommended for improved thermal performance and better EMI margin (due to lower PCB trace inductance).

## 10 Power Supply Recommendations

The DRV8962 is designed to operate from an input voltage supply (VM) range from 4.5 V to 65 V. A 0.01- $\mu\text{F}$  ceramic capacitor rated for VM must be placed close to the VM pins of DRV8962. In addition, a bulk capacitor must be included on VM.

### 10.1 Bulk Capacitance

Having appropriate local bulk capacitance is an important factor in system design. It is generally beneficial to have more bulk capacitance, while the disadvantages are increased cost and physical size.

The amount of local capacitance needed depends on a variety of factors, including:

- The highest current required by the system
- The power supply's capacitance and ability to source current
- The amount of parasitic inductance between the power supply and system
- The acceptable voltage ripple
- The type of motor used (brushed DC, brushless DC, stepper)
- The motor braking method

The inductance between the power supply and system will limit the rate current can change from the power supply. If the local bulk capacitance is too small, the system will respond to excessive current demands or dumps with a change in voltage. When adequate bulk capacitance is used, the voltage remains stable and high current can be quickly supplied.

The data sheet generally provides a recommended value, but system-level testing is required to determine the appropriate sized bulk capacitor.

The voltage rating for bulk capacitors should be higher than the operating voltage, to provide margin for cases when the motor transfers energy to the supply.

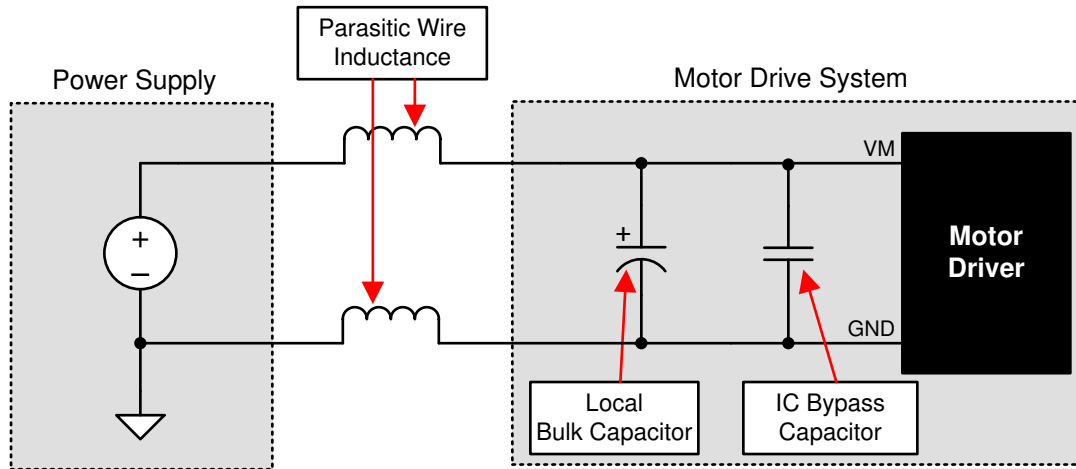

Copyright © 2016, Texas Instruments Incorporated

**Figure 10-1. Example Setup of System With External Power Supply**

### 10.2 Power Supplies

The DRV8962 needs only a single supply voltage connected to the VM pins.

- The VM pin provides the power supply to the half-Bridges.
- An internal voltage regulator provides a 5V supply (DVDD) for the digital and low-voltage analog circuitry. The DVDD pin is not recommended to be used as a voltage source for external circuitry.
- An external low-voltage supply can be connected to the VCC pin to power the internal circuitry. A 0.1- $\mu\text{F}$  decoupling capacitor should be placed close to the VCC pin to provide a constant voltage during transient.
- Additionally, the high-side gate drive requires a higher voltage supply, which is generated by built-in charge pump requiring external capacitors.

## 11 Layout

### 11.1 Layout Guidelines

- The VM pins should be bypassed to PGND pins using low-ESR ceramic bypass capacitors with a recommended value of 0.01  $\mu\text{F}$  rated for VM. The capacitors should be placed as close to the VM pins as possible with a thick trace or ground plane connection to the device PGND pins.
- The VM pins should be bypassed to PGND using a bulk capacitor rated for VM. This component can be an electrolytic capacitor.
- A low-ESR ceramic capacitor must be placed in between the CPL and CPH pins. A value of 0.1  $\mu\text{F}$  rated for VM is recommended. Place this component as close to the pins as possible.
- A low-ESR ceramic capacitor must be placed in between the VM and VCP pins. A value of 1  $\mu\text{F}$  rated for 16 V is recommended. Place this component as close to the pins as possible.
- Bypass the DVDD pin to ground with a low-ESR ceramic capacitor. A value of 1  $\mu\text{F}$  rated for 6.3 V is recommended. Place this bypassing capacitor as close to the pin as possible.
- Bypass the VCC pin to ground with a low-ESR ceramic capacitor. A value of 0.1  $\mu\text{F}$  rated for 6.3 V is recommended. Place this bypassing capacitor as close to the pin as possible.
- In general, inductance between the power supply pins and decoupling capacitors must be avoided.
- The thermal PAD of the DDW package must be connected to system ground.
  - It is recommended to use a big unbroken single ground plane for the whole system / board. The ground plane can be made at bottom PCB layer.
  - In order to minimize the impedance and inductance, the traces from ground pins should be as short and wide as possible, before connecting to bottom layer ground plane through vias.
  - Multiple vias are suggested to reduce the impedance.
  - Try to clear the space around the device as much as possible especially at bottom PCB layer to improve the heat spreading.
  - Single or multiple internal ground planes connected to the thermal PAD will also help spreading the heat and reduce the thermal resistance.

### 11.2 Layout Example

Follow the layout example of the DRV8962 EVM. The design files can be downloaded from the [DRV8962EVM](#) product folder.

## 12 Device and Documentation Support

TI offers an extensive line of development tools. Tools and software to evaluate the performance of the device, generate code, and develop solutions are listed below.

### 12.1 Related Documentation

- Texas Instruments, [How to Drive Unipolar Stepper Motors with DRV8xxx application report](#)
- Texas Instruments, [Calculating Motor Driver Power Dissipation application report](#)
- Texas Instruments, [Current Recirculation and Decay Modes application report](#)
- Texas Instruments, [Understanding Motor Driver Current Ratings application report](#)
- Texas Instruments, [Motor Drives Layout Guide application report](#)
- Texas Instruments, [Semiconductor and IC Package Thermal Metrics application report](#)
- Texas Instruments, [What Motor Drivers should be considered for driving TEC](#)

### 12.2 Receiving Notification of Documentation Updates

To receive notification of documentation updates, navigate to the device product folder on [ti.com](#). Click on *Subscribe to updates* to register and receive a weekly digest of any product information that has changed. For change details, review the revision history included in any revised document.

### 12.3 Support Resources

[TI E2E™ support forums](#) are an engineer's go-to source for fast, verified answers and design help — straight from the experts. Search existing answers or ask your own question to get the quick design help you need.

Linked content is provided "AS IS" by the respective contributors. They do not constitute TI specifications and do not necessarily reflect TI's views; see TI's [Terms of Use](#).

### 12.4 Trademarks

TI E2E™ is a trademark of Texas Instruments.  
All trademarks are the property of their respective owners.

### 12.5 Electrostatic Discharge Caution



This integrated circuit can be damaged by ESD. Texas Instruments recommends that all integrated circuits be handled with appropriate precautions. Failure to observe proper handling and installation procedures can cause damage.

ESD damage can range from subtle performance degradation to complete device failure. Precision integrated circuits may be more susceptible to damage because very small parametric changes could cause the device not to meet its published specifications.

### 12.6 Glossary

[TI Glossary](#) This glossary lists and explains terms, acronyms, and definitions.

## 13 Mechanical, Packaging, and Orderable Information

The following pages include mechanical, packaging, and orderable information. This information is the most current data available for the designated devices. This data is subject to change without notice and revision of this document. For browser-based versions of this data sheet, refer to the left-hand navigation.



## EXAMPLE BOARD LAYOUT

**DDW0044E**

**PowerPAD™ TSSOP - 1.2 mm max height**

PLASTIC SMALL OUTLINE

ADVANCE INFORMATION

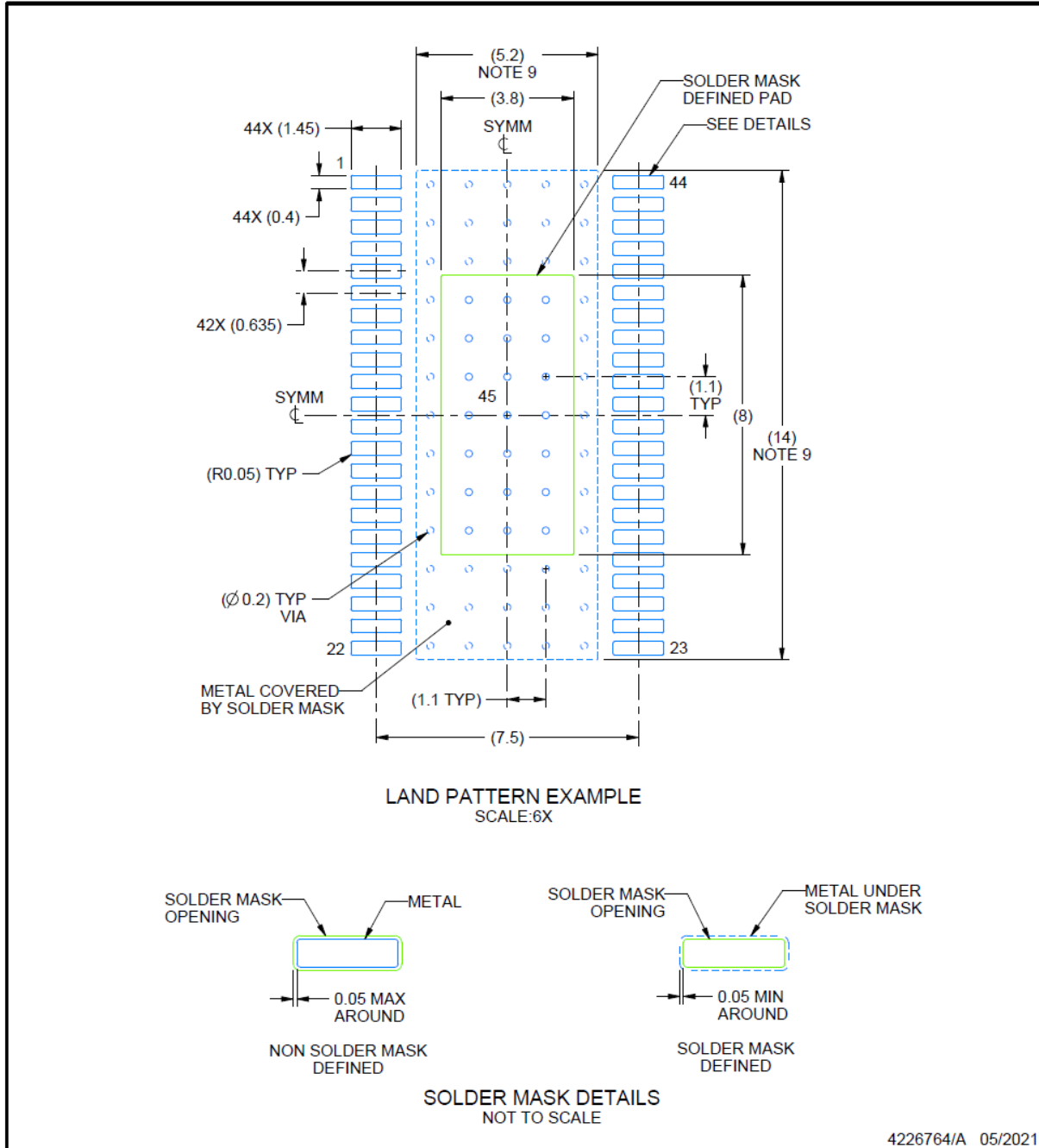

NOTES: (continued)

6. Publication IPC-7351 may have alternate designs.
7. Solder mask tolerances between and around signal pads can vary based on board fabrication site.
8. This package is designed to be soldered to a thermal pad on the board. For more information, see Texas Instruments literature numbers SLMA002 ([www.ti.com/lit/slma002](http://www.ti.com/lit/slma002)) and SLMA004 ([www.ti.com/lit/slma004](http://www.ti.com/lit/slma004)).
9. Size of metal pad may vary due to creepage requirement.



## EXAMPLE STENCIL DESIGN

DDW0044E

PowerPAD™ TSSOP - 1.2 mm max height

PLASTIC SMALL OUTLINE

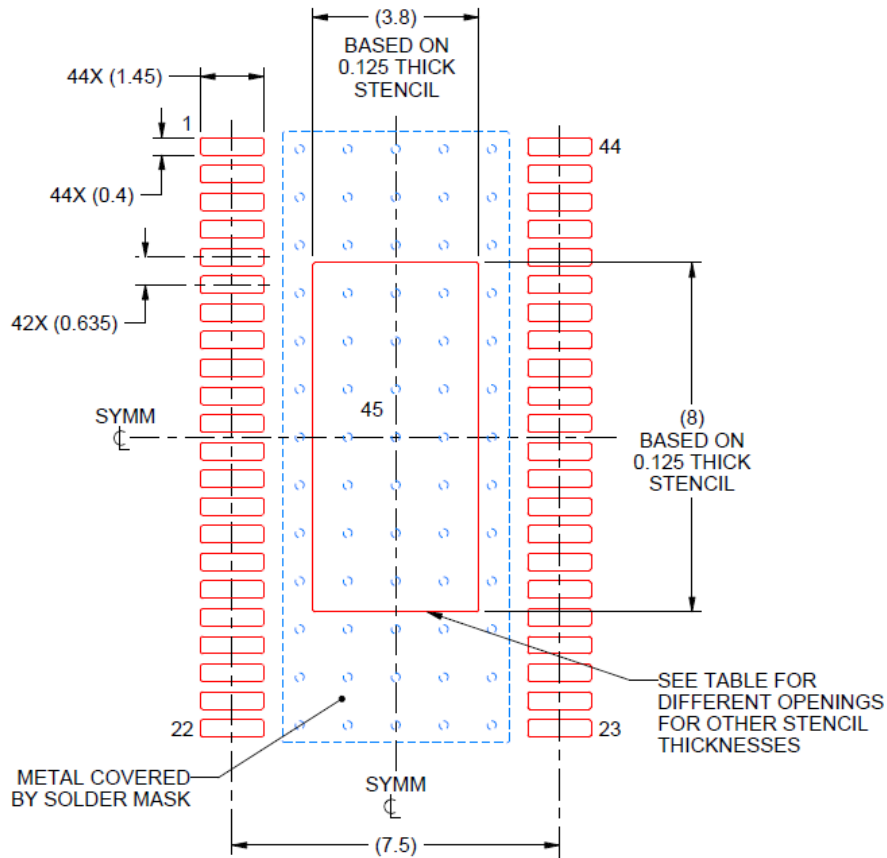

SOLDER PASTE EXAMPLE  
PAD 45:  
100% PRINTED SOLDER COVERAGE BY AREA  
SCALE:6X

STENCIL THICKNESS	SOLDER STENCIL OPENING
0.1	4.25 X 8.94
0.125	3.80 X 8.00 (SHOWN)
0.15	3.47 X 7.30
0.175	3.21 X 6.76

4226764/A 05/2021

NOTES: (continued)

10. Laser cutting apertures with trapezoidal walls and rounded corners may offer better paste release. IPC-7525 may have alternate design recommendations.
11. Board assembly site may have different recommendations for stencil design.

ADVANCE INFORMATION

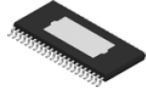

## PACKAGE OUTLINE

**DDV0044E**

**PowerPAD™ TSSOP - 1.2 mm max height**

PLASTIC SMALL OUTLINE

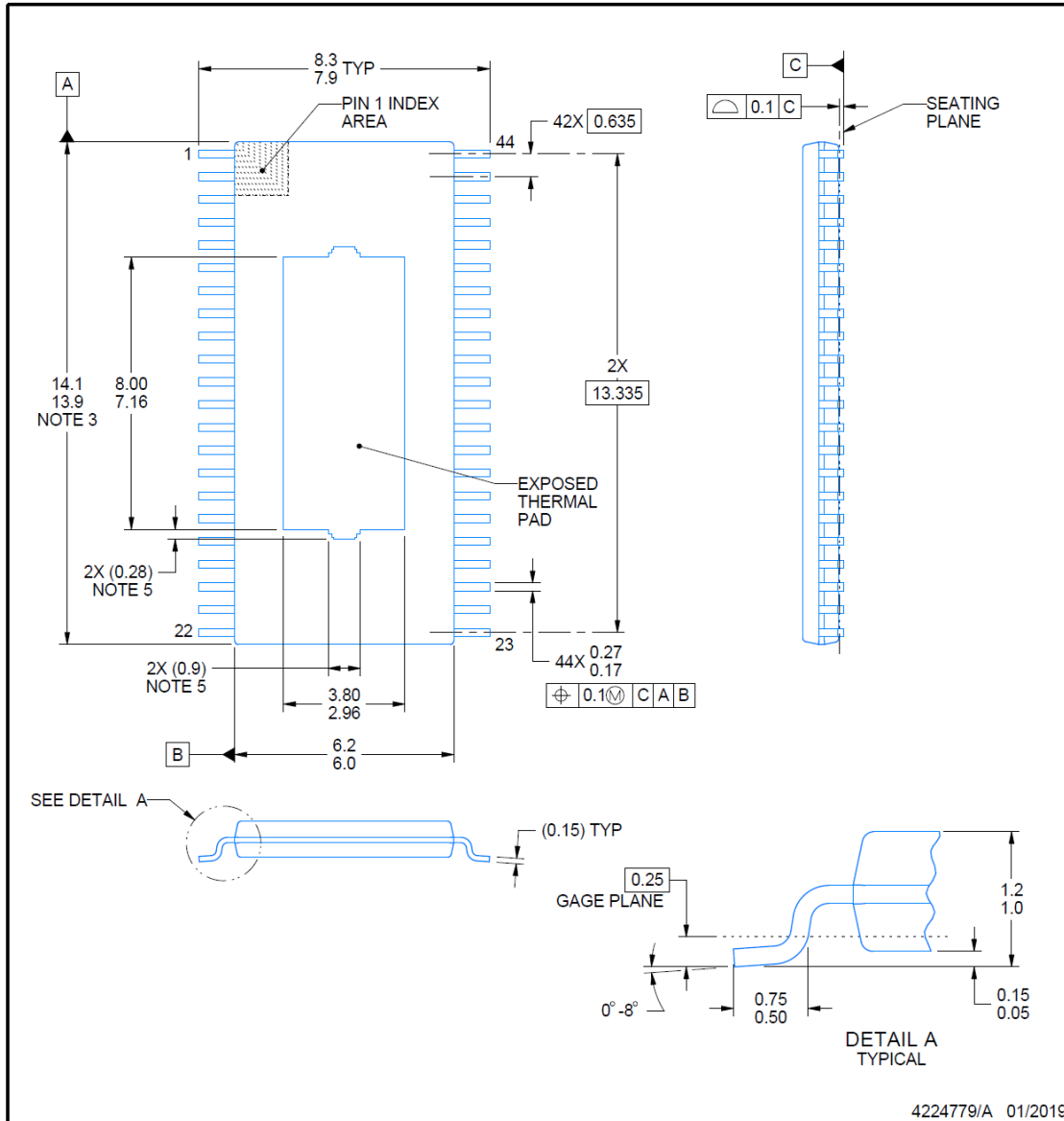

**NOTES:**

PowerPAD is a trademark of Texas Instruments.

1. All linear dimensions are in millimeters. Any dimensions in parenthesis are for reference only. Dimensioning and tolerancing per ASME Y14.5M.
2. This drawing is subject to change without notice.
3. This dimension does not include mold flash, protrusions, or gate burrs. Mold flash, protrusions, or gate burrs shall not exceed 0.15 mm per side.
4. Reference JEDEC registration MO-153.
5. The exposed thermal pad is designed to be attached to an external heatsink.
6. Features may differ or may not be present.

## EXAMPLE BOARD LAYOUT

**DDV0044E**

**PowerPAD™ TSSOP - 1.2 mm max height**

PLASTIC SMALL OUTLINE

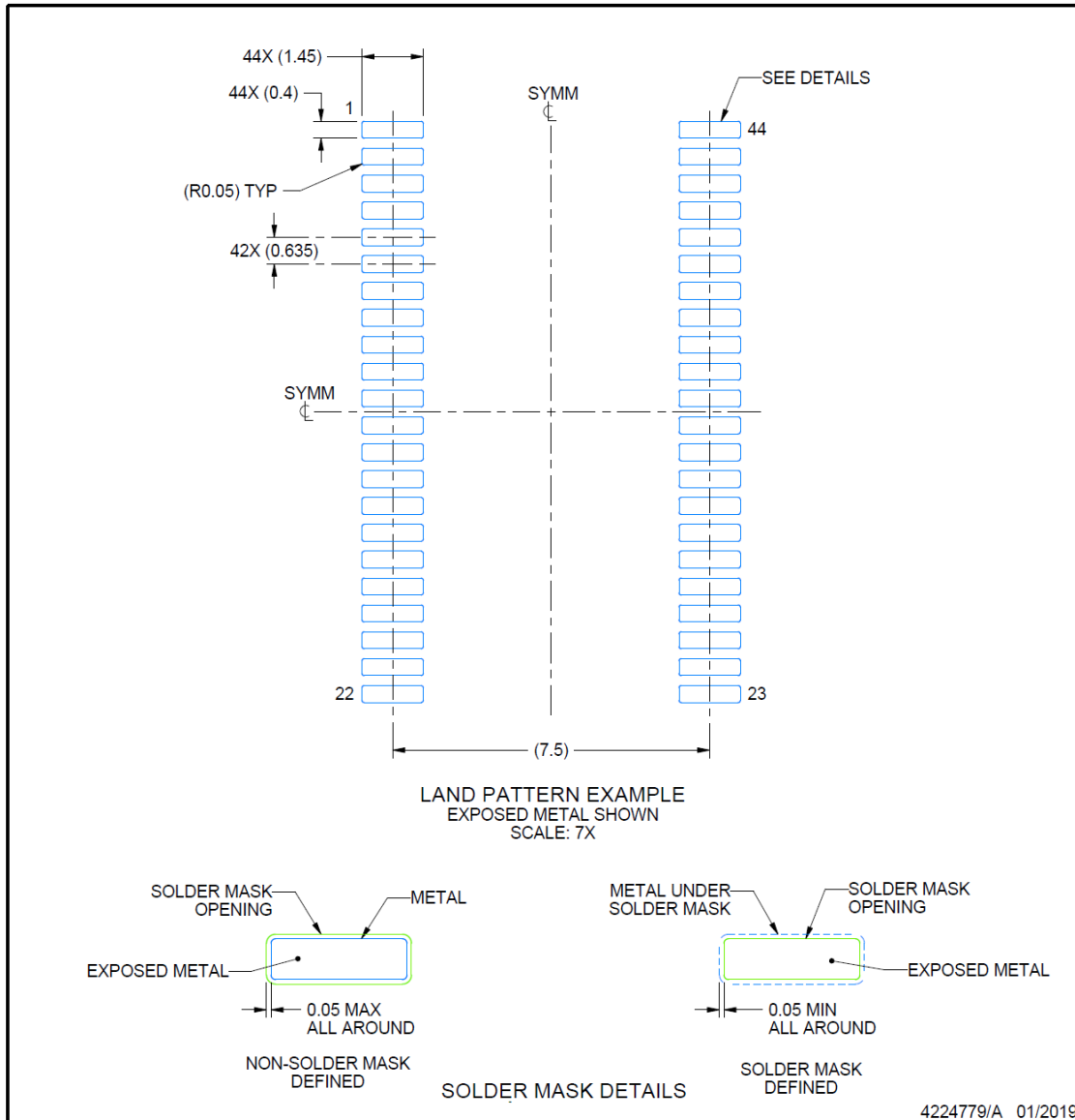

NOTES: (continued)

- 7. Publication IPC-7351 may have alternate designs.
- 8. Solder mask tolerances between and around signal pads can vary based on board fabrication site.

**ADVANCE INFORMATION**

## EXAMPLE STENCIL DESIGN

DDV0044E

PowerPAD™ TSSOP - 1.2 mm max height

PLASTIC SMALL OUTLINE

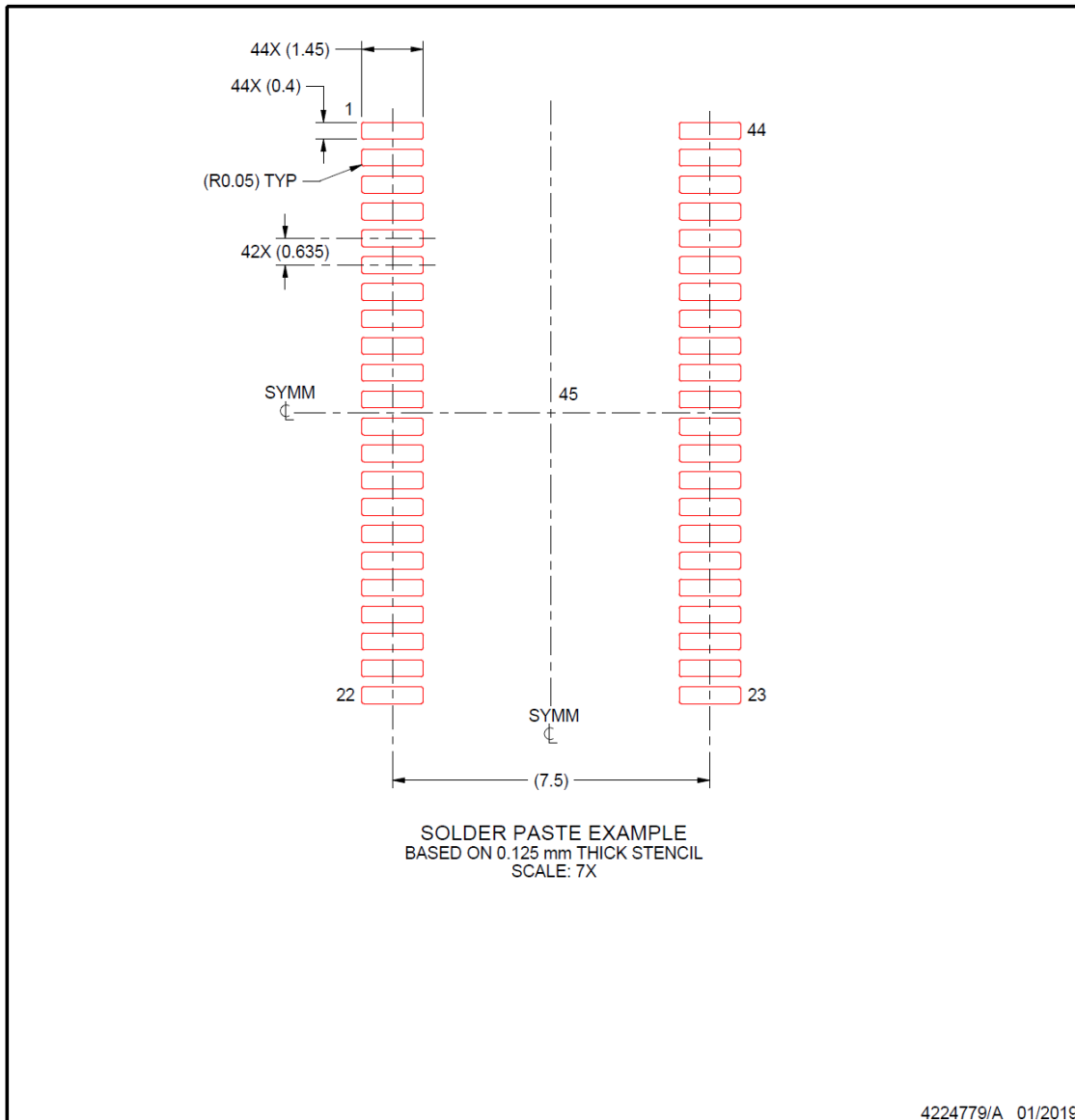

NOTES: (continued)

9. Laser cutting apertures with trapezoidal walls and rounded corners may offer better paste release. IPC-7525 may have alternate design recommendations.
10. Board assembly site may have different recommendations for stencil design.

### 13.1 Tape and Reel Information

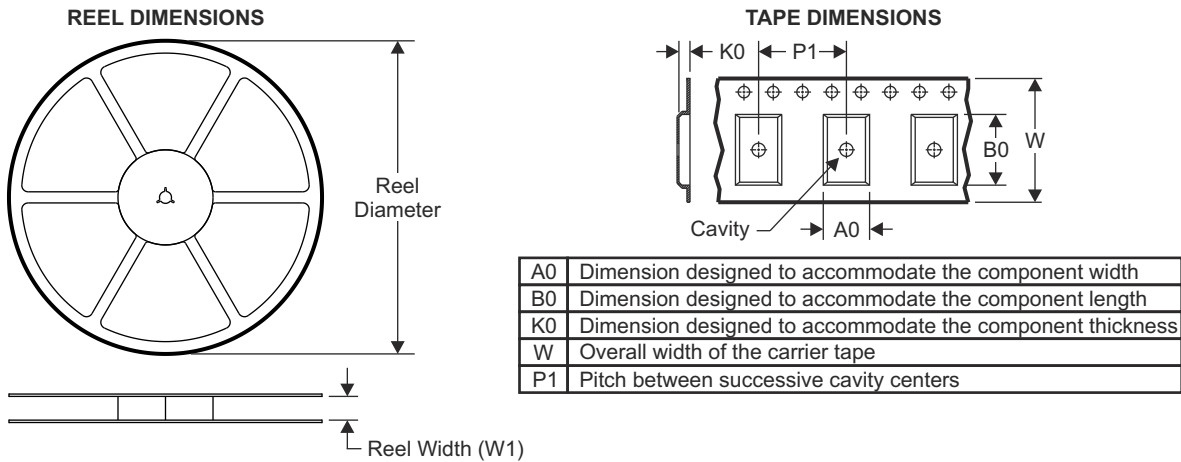

#### QUADRANT ASSIGNMENTS FOR PIN 1 ORIENTATION IN TAPE

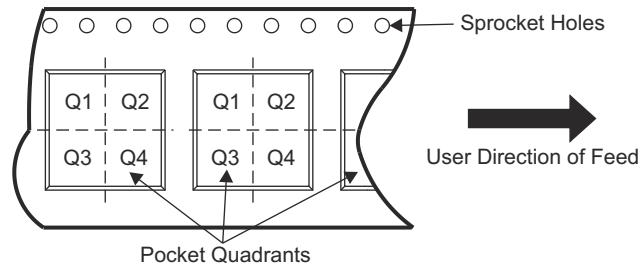

Device	Package Type	Package Drawing	Pins	SPQ	Reel Diameter (mm)	Reel Width W1 (mm)	A0 (mm)	B0 (mm)	K0 (mm)	P1 (mm)	W (mm)	Pin1 Quadrant
DRV8962DDWR	HTSSOP	DDW	44	2500	330	24.4	8.9	14.7	1.4	12	24	Q1
DRV8962DDVR	HTSSOP	DDV	44	2500	330	24.4	8.9	14.7	1.4	12	24	Q1

ADVANCE INFORMATION

TAPE AND REEL BOX DIMENSIONS

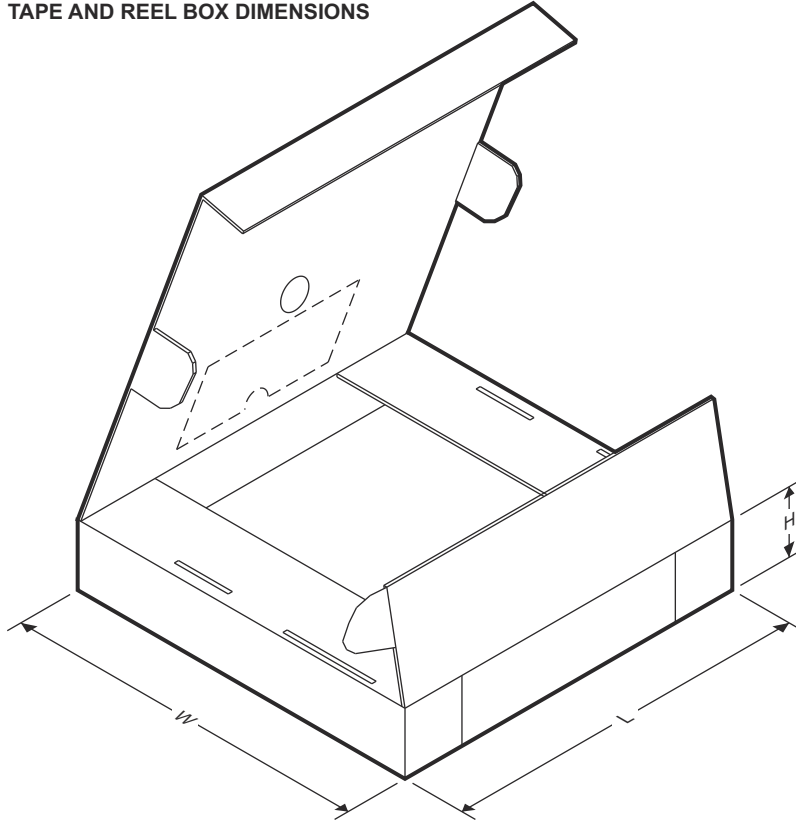

Device	Package Type	Package Drawing	Pins	SPQ	Length (mm)	Width (mm)	Height (mm)
DRV8962DDWR	HTSSOP	DDW	44	2500	367.0	367.0	45.0
DRV8962DDVR	HTSSOP	DDV	44	2500	367.0	367.0	45.0

ADVANCE INFORMATION

**PACKAGING INFORMATION**

Orderable Device	Status (1)	Package Type	Package Drawing	Pins	Package Qty	Eco Plan (2)	Lead finish/ Ball material (6)	MSL Peak Temp (3)	Op Temp (°C)	Device Marking (4/5)	Samples
PDRV8962DDWR	ACTIVE	HTSSOP	DDW	44	2500	TBD	Call TI	Call TI	-40 to 125		Samples

(1) The marketing status values are defined as follows:

**ACTIVE:** Product device recommended for new designs.

**LIFEBUY:** TI has announced that the device will be discontinued, and a lifetime-buy period is in effect.

**NRND:** Not recommended for new designs. Device is in production to support existing customers, but TI does not recommend using this part in a new design.

**PREVIEW:** Device has been announced but is not in production. Samples may or may not be available.

**OBSELETE:** TI has discontinued the production of the device.

(2) **RoHS:** TI defines "RoHS" to mean semiconductor products that are compliant with the current EU RoHS requirements for all 10 RoHS substances, including the requirement that RoHS substance do not exceed 0.1% by weight in homogeneous materials. Where designed to be soldered at high temperatures, "RoHS" products are suitable for use in specified lead-free processes. TI may reference these types of products as "Pb-Free".

**RoHS Exempt:** TI defines "RoHS Exempt" to mean products that contain lead but are compliant with EU RoHS pursuant to a specific EU RoHS exemption.

**Green:** TI defines "Green" to mean the content of Chlorine (Cl) and Bromine (Br) based flame retardants meet JS709B low halogen requirements of <=1000ppm threshold. Antimony trioxide based flame retardants must also meet the <=1000ppm threshold requirement.

(3) MSL, Peak Temp. - The Moisture Sensitivity Level rating according to the JEDEC industry standard classifications, and peak solder temperature.

(4) There may be additional marking, which relates to the logo, the lot trace code information, or the environmental category on the device.

(5) Multiple Device Markings will be inside parentheses. Only one Device Marking contained in parentheses and separated by a "~" will appear on a device. If a line is indented then it is a continuation of the previous line and the two combined represent the entire Device Marking for that device.

(6) Lead finish/Ball material - Orderable Devices may have multiple material finish options. Finish options are separated by a vertical ruled line. Lead finish/Ball material values may wrap to two lines if the finish value exceeds the maximum column width.

**Important Information and Disclaimer:**The information provided on this page represents TI's knowledge and belief as of the date that it is provided. TI bases its knowledge and belief on information provided by third parties, and makes no representation or warranty as to the accuracy of such information. Efforts are underway to better integrate information from third parties. TI has taken and continues to take reasonable steps to provide representative and accurate information but may not have conducted destructive testing or chemical analysis on incoming materials and chemicals. TI and TI suppliers consider certain information to be proprietary, and thus CAS numbers and other limited information may not be available for release.

In no event shall TI's liability arising out of such information exceed the total purchase price of the TI part(s) at issue in this document sold by TI to Customer on an annual basis.

## GENERIC PACKAGE VIEW

**DDW 44**

**PowerPAD TSSOP - 1.2 mm max height**

6.1 x 14, 0.635 mm pitch

PLASTIC SMALL OUTLINE

This image is a representation of the package family, actual package may vary.  
Refer to the product data sheet for package details.

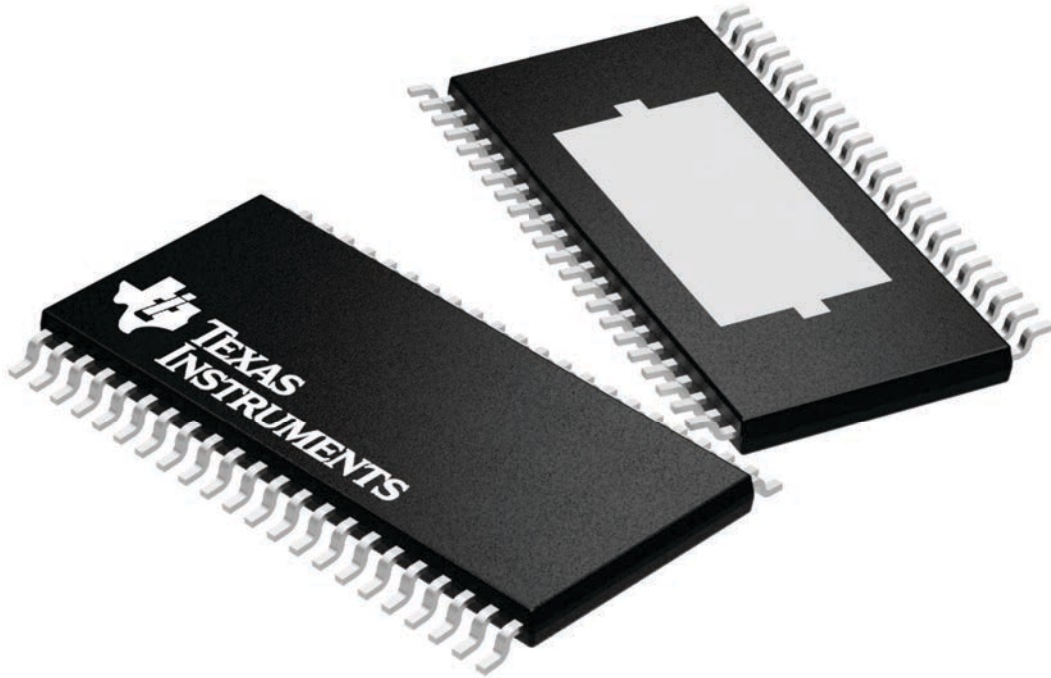

4224876/A



## IMPORTANT NOTICE AND DISCLAIMER

TI PROVIDES TECHNICAL AND RELIABILITY DATA (INCLUDING DATA SHEETS), DESIGN RESOURCES (INCLUDING REFERENCE DESIGNS), APPLICATION OR OTHER DESIGN ADVICE, WEB TOOLS, SAFETY INFORMATION, AND OTHER RESOURCES "AS IS" AND WITH ALL FAULTS, AND DISCLAIMS ALL WARRANTIES, EXPRESS AND IMPLIED, INCLUDING WITHOUT LIMITATION ANY IMPLIED WARRANTIES OF MERCHANTABILITY, FITNESS FOR A PARTICULAR PURPOSE OR NON-INFRINGEMENT OF THIRD PARTY INTELLECTUAL PROPERTY RIGHTS.

These resources are intended for skilled developers designing with TI products. You are solely responsible for (1) selecting the appropriate TI products for your application, (2) designing, validating and testing your application, and (3) ensuring your application meets applicable standards, and any other safety, security, regulatory or other requirements.

These resources are subject to change without notice. TI grants you permission to use these resources only for development of an application that uses the TI products described in the resource. Other reproduction and display of these resources is prohibited. No license is granted to any other TI intellectual property right or to any third party intellectual property right. TI disclaims responsibility for, and you will fully indemnify TI and its representatives against, any claims, damages, costs, losses, and liabilities arising out of your use of these resources.

TI's products are provided subject to [TI's Terms of Sale](#) or other applicable terms available either on [ti.com](http://ti.com) or provided in conjunction with such TI products. TI's provision of these resources does not expand or otherwise alter TI's applicable warranties or warranty disclaimers for TI products.

TI objects to and rejects any additional or different terms you may have proposed.

Mailing Address: Texas Instruments, Post Office Box 655303, Dallas, Texas 75265  
Copyright © 2022, Texas Instruments Incorporated