

ESD752 and ESD7x2 24-V, 2-Channel, ESD Protection With 5.7 A of 8/20 μ s Surge Protection in a SOT-23 and SOT-323 / SC-70 Package

1 Features

- Robust surge protection:
 - IEC 61000-4-5 (8/20 μ s): 5.7 A
- IEC 61000-4-2 level 4 ESD protection:
 - \pm 30-kV or \pm 20-kV contact discharge
 - \pm 30-kV or \pm 20-kV air-gap discharge
- 24 V working voltage
- Bidirectional ESD protection
- 2-channel device provides complete ESD and surge protection with single component
- Low clamping voltage protects downstream components
- I/O capacitance = 3 pF or 1.7 pF (typical)
- SOT-23 (DBZ) small, standard, common footprint
- SOT-323 / SC-70 (DCK) very small, standard, space saving, common footprint
- Leaded packages used for automatic optical inspection (AOI)

2 Applications

- USB power delivery (USB-PD):
 - VBUS protection
 - IO protection (withstand short to VBUS)
- **Industrial control networks:**
 - Smart distribution system (SDS)
 - DeviceNet IEC 62026-3
 - CANopen – CiA 301/302-2 and EN 50325-4
 - 4/20 mA circuits
 - PLC surge protection
 - ADC surge protection

3 Description

The ESD752 and ESD7x2 are bidirectional ESD protection diodes for USB power delivery (USB-PD) and industrial interfaces. The ESD752 and ESD7x2 are rated to dissipate contact ESD that meets or exceeds the maximum level specified in the IEC 61000-4-2 level 4 standard (\pm 30-kV or \pm 20-kV contact and \pm 30-kV or \pm 20-kV airgap). The low dynamic resistance and low clamping voltage ensures system level protection against transient events. This protection is key because industrial systems require a high level of robustness and reliability.

These devices feature a low IO capacitance per channel and a pin-out to suit two IO lines from damage caused by electrostatic discharge (ESD) and other transients. The $I_{PP} = 5.7$ A (8/20 μ s surge waveform) capability of the ESD752 makes it suitable for protecting USB VBUS against transient surge events as well as industrial I/O lines. Additionally, the 3 pF or 1.7 pF line capacitance of the ESD752 and ESD7x2 are suitable for protecting the slower speed signals for USB power delivery and IO signals for industrial applications.

The ESD752 and ESD7x2 are offered in two leaded packages for easy flow through routing.

Package Information⁽¹⁾

PART NUMBER	PACKAGE	BODY SIZE (NOM)
ESD752	DCK (SOT-323 / SC-70, 3)	2.00 mm \times 1.25 mm
	DBZ (SOT-23, 3)	2.92 mm \times 1.30 mm
ESD7x2	DBZ (SOT-23, 3)	2.92 mm \times 1.30 mm

(1) For all available packages, see the orderable addendum at the end of the data sheet.

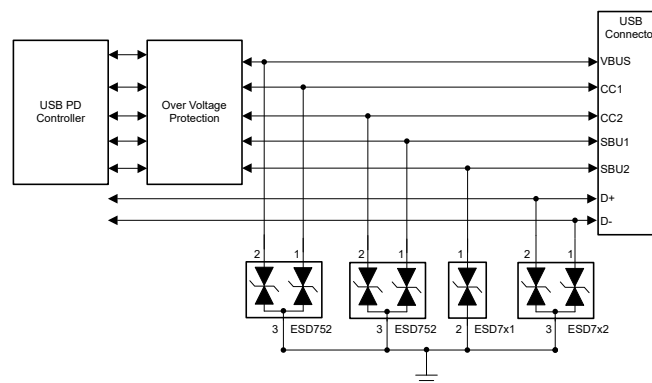

USB Power Delivery Typical Application



Table of Contents

1 Features	1	7.4 Device Functional Modes.....	9
2 Applications	1	8 Application and Implementation	10
3 Description	1	8.1 Application Information.....	10
4 Revision History	2	8.2 Typical Application.....	10
5 Pin Configuration and Functions	3	9 Power Supply Recommendations	11
6 Specifications	4	10 Layout	11
6.1 Absolute Maximum Ratings.....	4	10.1 Layout Guidelines.....	11
6.2 ESD Ratings—JEDEC Specification.....	4	10.2 Layout Example.....	12
6.3 ESD Ratings—IEC Specification.....	4	11 Device and Documentation Support	13
6.4 Recommended Operating Conditions.....	4	11.1 Documentation Support.....	13
6.5 Thermal Information.....	4	11.2 Receiving Notification of Documentation Updates..	13
6.6 Electrical Characteristics.....	5	11.3 Support Resources.....	13
6.7 Typical Characteristics.....	6	11.4 Trademarks.....	13
7 Detailed Description	8	11.5 Electrostatic Discharge Caution.....	13
7.1 Overview.....	8	11.6 Glossary.....	13
7.2 Functional Block Diagram.....	8	12 Mechanical, Packaging, and Orderable Information	13
7.3 Feature Description.....	8		

4 Revision History

NOTE: Page numbers for previous revisions may differ from page numbers in the current version.

Changes from Revision * (May 2022) to Revision A (August 2022)	Page
• Changed the status of the data sheet from: <i>Advanced Information</i> to: <i>Production Data</i>	1

5 Pin Configuration and Functions

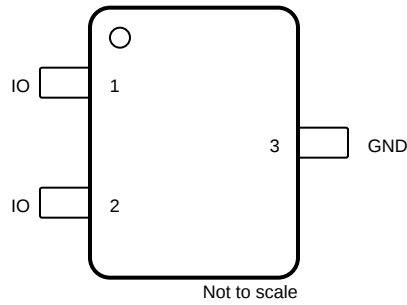

Figure 5-1. DCK and DBZ Package, 3-Pin SOT-323 / SC-70 and SOT-23 (Top View)

Table 5-1. Pin Functions

PIN		TYPE ⁽¹⁾	DESCRIPTION
NAME	NO.		
IO	1, 2	I/O	ESD protected IO
GND	3	—	Connect to ground.

(1) I/O = Input or Output,

6 Specifications

6.1 Absolute Maximum Ratings

over operating free-air temperature range (unless otherwise noted)⁽¹⁾

PARAMETER		DEVICE	MIN	MAX	UNIT
Peak pulse	IEC 61000-4-5 Power ($t_p = 8/20 \mu\text{s}$) at 25°C	ESD752		210	W
	IEC 61000-4-5 current ($t_p = 8/20 \mu\text{s}$) at 25°C	ESD752		5.7	A
T_A	Operating free-air temperature		-55	150	°C
T_J	Junction temperature		-55	150	°C
T_{stg}	Storage temperature		-65	155	°C

- (1) Operation outside the Absolute Maximum Ratings may cause permanent device damage. Absolute Maximum Ratings do not imply functional operation of the device at these or any other conditions beyond those listed under Recommended Operating Conditions. If used outside the Recommended Operating Conditions but within the Absolute Maximum Ratings, the device may not be fully functional, and this may affect device reliability, functionality, performance, and shorten the device lifetime.

6.2 ESD Ratings—JEDEC Specification

PARAMETER	TEST CONDITION	VALUE	UNIT
$V_{\text{(ESD)}}$	Human body model (HBM), per ANSI/ESDA/JEDEC JS-001	± 2500	V
	Charged device model (CDM), per JEDEC specification JS-002	± 1000	

6.3 ESD Ratings—IEC Specification

PARAMETER	TEST CONDITION	DEVICE	VALUE	UNIT
$V_{\text{(ESD)}}$	IEC 61000-4-2 Contact Discharge, all pins	ESD752	±30000	V
	IEC 61000-4-2 Air Discharge, all pins		±30000	

6.4 Recommended Operating Conditions

PARAMETER	MIN	NOM	MAX	UNIT
V_{IN}	Input voltage	-24	24	V
T_A	Operating free-air temperature	-55	150	°C

6.5 Thermal Information

THERMAL METRIC ⁽¹⁾		ESD752		ESD7x2	UNIT
		DBZ (SOT-23)	DCK (SOT-323 / SC-70)	DBZ (SOT-23)	
		3 PINS	3PINS	3 PINS	
$R_{\theta\text{JA}}$	Junction-to-ambient thermal resistance	291.5	283.0	TBD	°C/W
$R_{\theta\text{JC(top)}}$	Junction-to-case (top) thermal resistance	147.1	164.1	TBD	°C/W
$R_{\theta\text{JB}}$	Junction-to-board thermal resistance	131.1	105.1	TBD	°C/W
Ψ_{JT}	Junction-to-top characterization parameter	32.0	67.1	TBD	°C/W
Ψ_{JB}	Junction-to-board characterization parameter	130.2	104.4	TBD	°C/W
$R_{\theta\text{JC(bot)}}$	Junction-to-case (bottom) thermal resistance	N/A	N/A	N/A	°C/W

- (1) For more information about traditional and new thermal metrics, see the [Semiconductor and IC Package Thermal Metrics](#) application report.

6.6 Electrical Characteristics

over $T_A = 25^\circ\text{C}$ (unless otherwise noted)⁽¹⁾

PARAMETER		TEST CONDITIONS	DEVICE	MIN	TYP	MAX	UNIT
V_{RWM}	Reverse stand-off voltage		ESD752	-24		24	V
V_{BRF}	Forward breakdown voltage ⁽²⁾	$I_{IO} = 10\text{ mA}$, IO to GND	ESD752	25.5		35.5	V
V_{BRR}	Reverse breakdown voltage ⁽²⁾	$I_{IO} = -10\text{ mA}$, IO to GND	ESD752	-35.5		-25.5	V
V_{CLAMP}	Clamping voltage ⁽⁴⁾	$I_{PP} = 5.7\text{ A}$, $t_p = 8/20\ \mu\text{s}$, IO to GND	ESD752	37			V
	Clamping voltage ⁽⁵⁾	$I_{PP} = 16\text{ A}$, TLP, IO to GND or GND to IO		35			
V_{Hold}	Holding voltage after snapback ⁽³⁾	TLP	ESD752	30			V
I_{LEAK}	Leakage current	$V_{IO} = \pm 24\text{ V}$, IO to GND	ESD752	-50	5	50	nA
R_{DYN}	Dynamic resistance ⁽⁵⁾	IO to GND	ESD752	0.35			Ω
		GND to IO		0.35			
C_L	Line capacitance ⁽⁶⁾	$V_{IO} = 0\text{ V}$, $f = 1\text{ MHz}$, $V_{pp} = 30\text{ mV}$	ESD752	3		5	pF

(1) Measurements made on both IO channels.

(2) V_{BRF} and V_{BRR} are defined as the voltage when $\pm 10\text{ mA}$ is applied in the positive or negative direction respectively, before the device latches into the snapback state.

(3) V_{HOLD} is defined as the lowest voltage on the TLP plot once the trigger threshold is reached and the device snaps back and begins clamping the voltage.

(4) Device stressed with 8/20 μs exponential decay waveform according to IEC 61000-4-5.

(5) Non-repetitive current pulse, Transmission Line Pulse (TLP); square pulse; ANSI / ESD STM5.5.1-2008.

(6) Measured from IO to GND on both channels.

6.7 Typical Characteristics

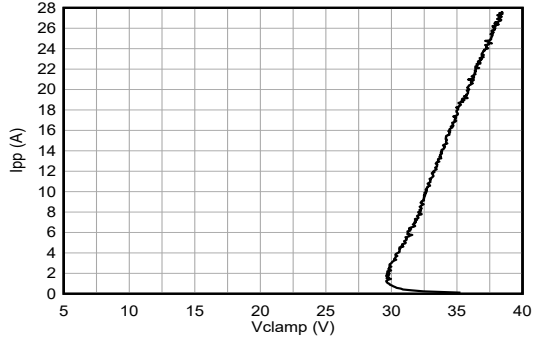

tp = 100 ns, Transmission Line Pulse (TLP)

Figure 6-1. Positive TLP Curve

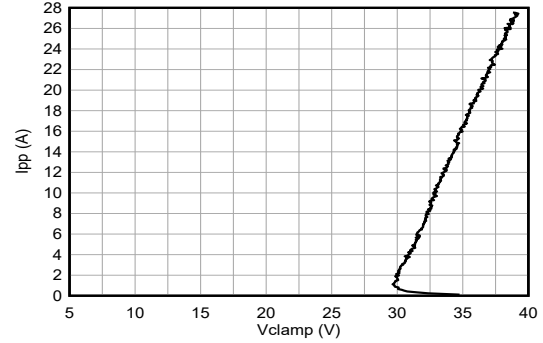

tp = 100 ns, Transmission Line Pulse (TLP)

Figure 6-2. Negative TLP Curve

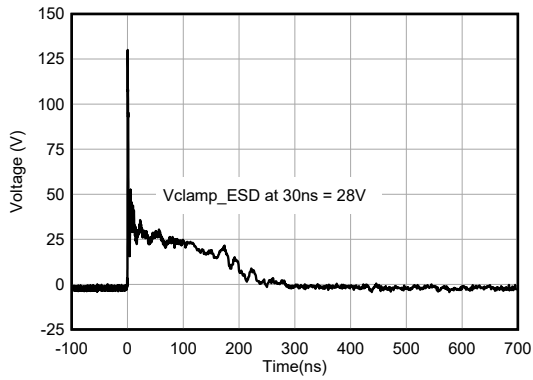

Figure 6-3. +8-kV Clamped IEC Waveform

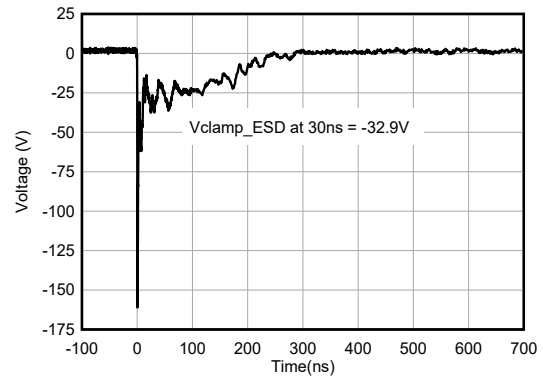

Figure 6-4. -8-kV Clamped IEC Waveform

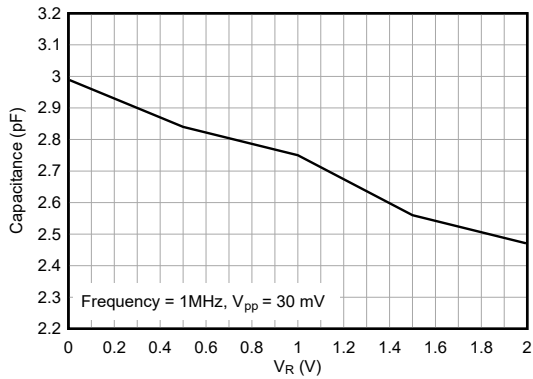

Figure 6-5. Capacitance vs. Bias Voltage

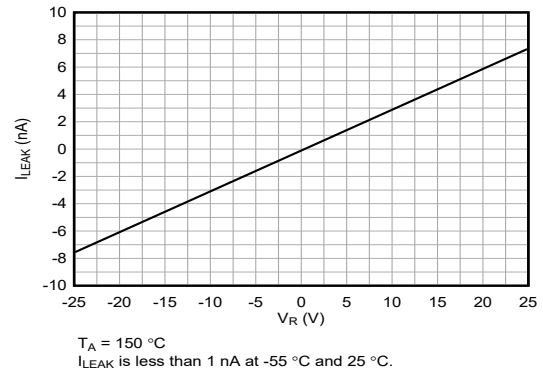

Figure 6-6. Leakage Current vs. Bias Voltage Across Temperature

6.7 Typical Characteristics (continued)

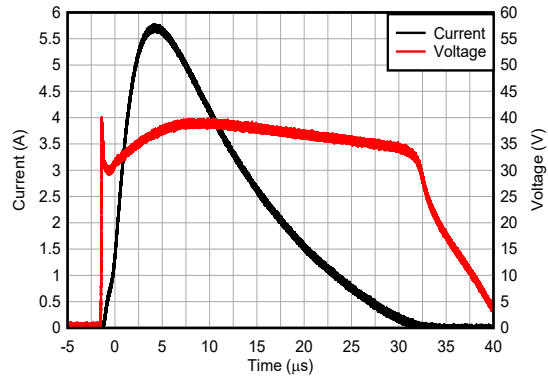

Figure 6-7. 8/20 μs Surge Response at 5.7 A

7 Detailed Description

7.1 Overview

The ESD752 and ESD7x2 are dual-channel ESD TVS diodes in SOT-23 and SOT-323 (SC-70) leaded packages which are convenient for automatic optical inspection. This product offers IEC 61000-4-2 ± 30 -kV or ± 20 -kV air-gap, ± 30 -kV or ± 20 -kV contact ESD protection respectively, and has a clamp circuit with a back-to-back TVS diode for bidirectional signal support.

A typical application of this product is the ESD protection for USB-PD slower speed signals (CC1, CC2, SBU1, SBU2, D+, and D-). The $I_{PP} = 5.7$ A (8/20 μ s surge waveform) capability of the ESD752 makes it suitable for protecting VBUS. The ESD752 device is also a good fit for protecting industrial IOs requiring 5.7 A or less of surge current protection. The 3 pF or 1.7 pF line capacitance of these ESD protection diodes are suitable for USB-PD slower speed signals and industrial IO applications.

7.2 Functional Block Diagram

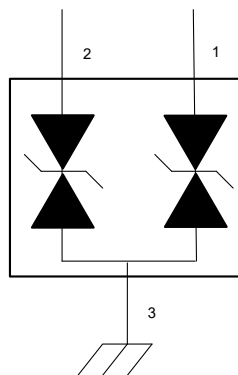

7.3 Feature Description

The ESD752 and ESD7x2 are bidirectional TVS diodes with a high ESD protection level. This device protects the circuit from ESD strikes up to ± 30 -kV or ± 20 -kV contact and ± 30 -kV or ± 20 -kV air-gap respectively as specified in the IEC 61000-4-2 standard. The ESD752 and ESD7x2 can also handle up to 5.7 A or 1.5 A of surge current (IEC 61000-4-5 8/20 μ s) respectively. The I/O capacitance of 3 pF or 1.7 pF are suitable for USB power delivery slower speed signals and industrial applications. These clamping devices have a small dynamic resistance, which makes the clamping voltage low when the device is actively protecting other circuits. For example, the ESD752 clamping voltage is only 37 V when the device is taking 5.7 A transient current. The breakdown is bidirectional so these protection devices are a good fit for applications requiring positive and negative polarity protection. Low leakage allows these diodes to conserve power when working below the V_{RWM} . The temperature range of -55°C to $+150^{\circ}\text{C}$ makes this ESD device work at extensive temperatures in most environments. The leaded SOT-23 and SOT-323 (SC-70) packages are good for applications requiring automatic optical inspection (AOI).

7.3.1 Temperature Range

These devices are qualified to operate from -55°C to $+150^{\circ}\text{C}$.

7.3.2 IEC 61000-4-5 Surge Protection

The IO pins can withstand surge events up to 5.7 A and 1.5 A (8/20 μ s waveform) for the ESD752 and ESD7x2 respectively. An ESD-surge clamp diverts this current to ground.

7.3.3 IO Capacitance

The capacitance between the I/O pins is 3 pF and 1.7 pF for the ESD752 and ESD7x2 respectively. These capacitances are suitable for USB power delivery slower speed signals and industrial applications.

7.3.4 Dynamic Resistance

The IO pins feature an ESD clamp that has a low R_{DYN} of 0.35 Ω for the ESD752 device, and 0.57 Ω for the ESD7x2 device, which prevents system damage during ESD events.

7.3.5 DC Breakdown Voltage

The DC breakdown voltage between the IO pins is a minimum of ± 25.5 V. This ensures that sensitive equipment is protected from surges above the reverse standoff voltage of ± 24 V.

7.3.6 Ultra Low Leakage Current

The IO pins feature an ultra-low leakage current of 50 nA (maximum) with a bias of ± 24 V.

7.3.7 Clamping Voltage

The IO pins feature an ESD clamp that is capable of clamping the voltage to 37 V ($I_{PP} = 5.7$ A for 8/20 μ s surge waveform), 35 V ($I_{PP} = 16$ A for TLP), 36 V ($I_{PP} = 1.5$ A for 8/20 μ s surge waveform), and 38 V ($I_{PP} = 16$ A for TLP) for the ESD752 and ESD7x2, respectively.

7.3.8 Industry Standard Leaded Packages

These devices feature industry standard SOT-23 (DBZ) and SC-70 (DCK) leaded packages for automatic optical inspection (AOI).

7.4 Device Functional Modes

The ESD752 and ESD7x2 are dual channel passive clamp devices that have low leakage during normal operation when the voltage between IO and GND is below V_{RWM} , and activate when the voltage between IO and GND goes above V_{BR} . During IEC 61000-4-2 ESD events, transient voltages as high as ± 30 kV can be clamped on either channel. When the voltages on the protected lines fall below the V_{HOLD} , the device reverts back to the low leakage passive state.

8 Application and Implementation

Note

Information in the following applications sections is not part of the TI component specification, and TI does not warrant its accuracy or completeness. TI's customers are responsible for determining suitability of components for their purposes, as well as validating and testing their design implementation to confirm system functionality.

8.1 Application Information

The ESD752 and ESD7x2 are dual channel TVS diodes which are used to provide a path to ground for dissipating ESD events on USB-PD or industrial IO signal lines. As the current from the ESD passes through the TVS, only a small voltage drop is present across the diode. This is the voltage presented to the protected IC. The low R_{DYN} of the triggered TVS holds this voltage (V_{CLAMP}) to a safe level for the protected IC.

8.2 Typical Application

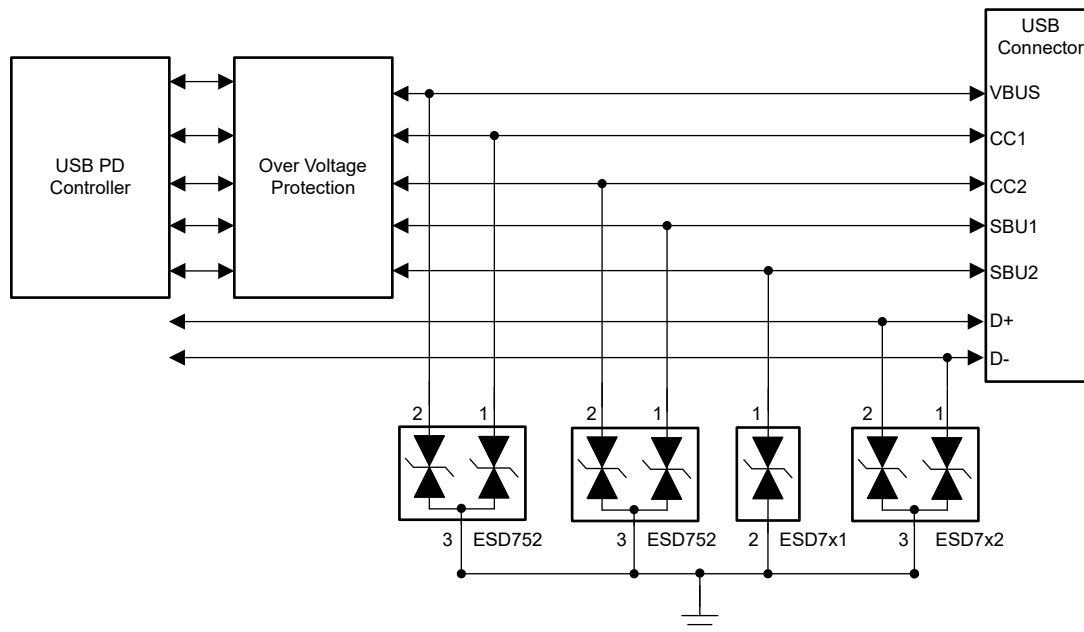

Figure 8-1. USB Power Delivery Typical Application

8.2.1 Application

8.2.2 Design Requirements

For this design example, the ESD752 and ESD7x2 are used to provide ESD protection on a USB-PD connector. [Table 8-1](#) lists the known design parameters for this application.

Table 8-1. Design Parameters for the USB Power Delivery Typical Application

Design Parameter	Value
Diode configuration	Bidirectional
VBUS Voltage	+ 20 V
V_{IO} signal range	+ 3.3 V
V_{RWM}	± 24 V
Short to VBUS event on V_{IO}	± 20 V
Data rate	Up to 480 Mbps

8.2.3 Detailed Design Procedure

The ESD752 and ESD7x2 has a V_{RWM} of ± 24 V to prevent the diode from being damaged during a short event that can occur when one of the USB-PD slower speed lines (CC1, CC2, SBU1, SBU2, D+, and D-) is shorted to VBUS. The bidirectional characteristic ensures both positive and negative polarity are protected. The low 1.7 pF capacitance of the ESD7x2 device ensures data rates up to 480 Mbps, which allows the designer to meet the requirements for the D+ and D- signals. The ESD752 has an $I_{PP} = 5.7$ A (8/20 μ s) surge current capability making it suitable for protecting the VBUS power rail.

8.2.4 Application Curves

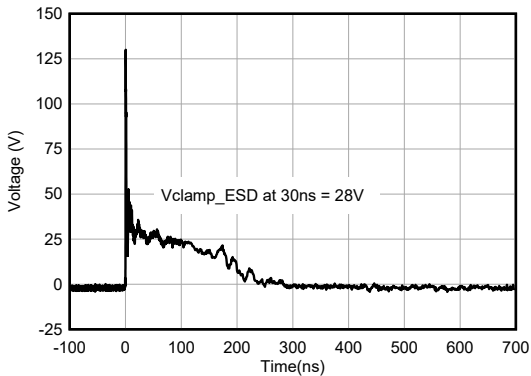

Figure 8-2. +8-kV Clamped IEC Waveform

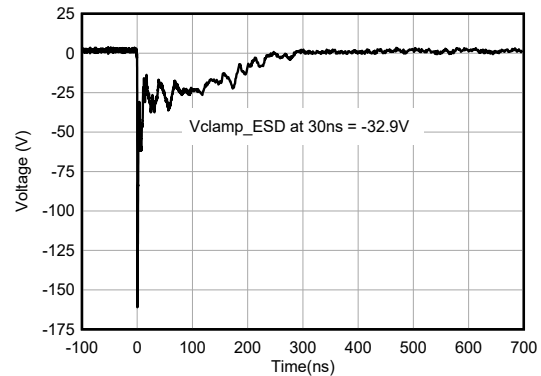

Figure 8-3. -8-kV Clamped IEC Waveform

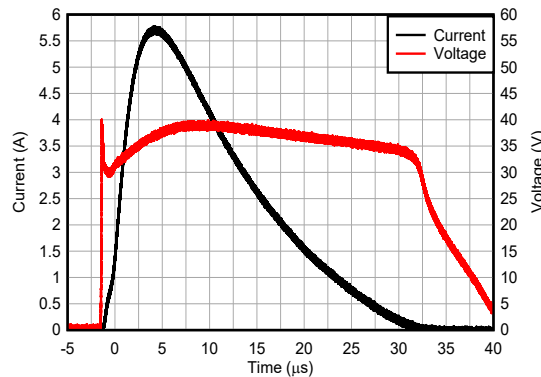

Figure 8-4. 8/20 μ s Surge Response at 5.7 A

9 Power Supply Recommendations

These are passive TVS diode-based ESD protection devices; therefore, there is no requirement to power it. Ensure that the maximum voltage specifications for each pin are not violated.

10 Layout

10.1 Layout Guidelines

- The optimum placement is as close to the connector as possible.
 - EMI during an ESD event can couple from the trace being struck to other nearby unprotected traces, resulting in early system failures.
 - The PCB designer must minimize the possibility of EMI coupling by keeping any unprotected traces away from the protected traces which are between the TVS and the connector.
- Route the protected traces as straight as possible.
- Eliminate any sharp corners on the protected traces between the TVS and the connector by using rounded corners with the largest radii possible.
 - Electric fields tend to build up on corners, increasing EMI coupling.
- If pin 3 is connected to ground, use a thick and short trace for this return path.

10.2 Layout Example

This is a typical example of a dual channel IO routing.

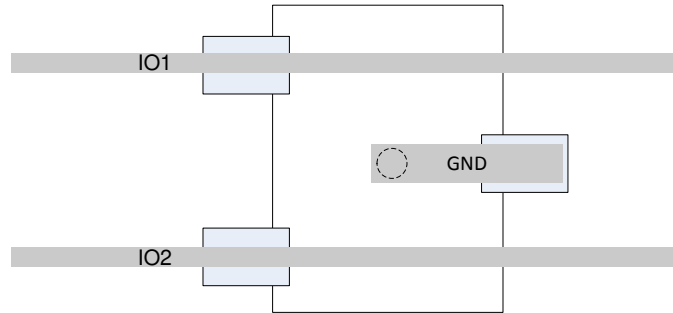

 = VIA to GND

Figure 10-1. Routing with DBZ and DCK Package

11 Device and Documentation Support

TI offers an extensive line of development tools. Tools and software to evaluate the performance of the device, generate code, and develop solutions are listed below.

11.1 Documentation Support

11.1.1 Related Documentation

For related documentation, see the following:

- Texas Instruments, [ESD Layout Guide user's guide](#)
- Texas Instruments, [ESD and Surge Protection for USB Interfaces application note](#)
- Texas Instruments, [ESD Protection Diodes EVM user's guide](#)
- Texas Instruments, [Generic ESD Evaluation Module user's guide](#)
- Texas Instruments, [Reading and Understanding an ESD Protection data sheet](#)

11.2 Receiving Notification of Documentation Updates

To receive notification of documentation updates, navigate to the device product folder on [ti.com](#). Click on *Subscribe to updates* to register and receive a weekly digest of any product information that has changed. For change details, review the revision history included in any revised document.

11.3 Support Resources

TI E2E™ [support forums](#) are an engineer's go-to source for fast, verified answers and design help — straight from the experts. Search existing answers or ask your own question to get the quick design help you need.

Linked content is provided "AS IS" by the respective contributors. They do not constitute TI specifications and do not necessarily reflect TI's views; see TI's [Terms of Use](#).

11.4 Trademarks

TI E2E™ is a trademark of Texas Instruments.

All trademarks are the property of their respective owners.

11.5 Electrostatic Discharge Caution



This integrated circuit can be damaged by ESD. Texas Instruments recommends that all integrated circuits be handled with appropriate precautions. Failure to observe proper handling and installation procedures can cause damage.

ESD damage can range from subtle performance degradation to complete device failure. Precision integrated circuits may be more susceptible to damage because very small parametric changes could cause the device not to meet its published specifications.

11.6 Glossary

[TI Glossary](#) This glossary lists and explains terms, acronyms, and definitions.

12 Mechanical, Packaging, and Orderable Information

The following pages include mechanical, packaging, and orderable information. This information is the most current data available for the designated devices. This data is subject to change without notice and revision of this document. For browser-based versions of this data sheet, refer to the left-hand navigation.

PACKAGING INFORMATION

Orderable Device	Status (1)	Package Type	Package Drawing	Pins	Package Qty	Eco Plan (2)	Lead finish/ Ball material (6)	MSL Peak Temp (3)	Op Temp (°C)	Device Marking (4/5)	Samples
ESD752DBZR	ACTIVE	SOT-23	DBZ	3	3000	RoHS & Green	NIPDAU	Level-1-260C-UNLIM	-55 to 150	2RP8	Samples
PESD752DBZR	ACTIVE	SOT-23	DBZ	3	3000	TBD	Call TI	Call TI	-55 to 150		Samples
PESD752DCKR	ACTIVE	SC70	DCK	3	3000	TBD	Call TI	Call TI	-55 to 150		Samples

(1) The marketing status values are defined as follows:

ACTIVE: Product device recommended for new designs.

LIFEBUY: TI has announced that the device will be discontinued, and a lifetime-buy period is in effect.

NRND: Not recommended for new designs. Device is in production to support existing customers, but TI does not recommend using this part in a new design.

PREVIEW: Device has been announced but is not in production. Samples may or may not be available.

OBSOLETE: TI has discontinued the production of the device.

(2) **RoHS:** TI defines "RoHS" to mean semiconductor products that are compliant with the current EU RoHS requirements for all 10 RoHS substances, including the requirement that RoHS substance do not exceed 0.1% by weight in homogeneous materials. Where designed to be soldered at high temperatures, "RoHS" products are suitable for use in specified lead-free processes. TI may reference these types of products as "Pb-Free".

RoHS Exempt: TI defines "RoHS Exempt" to mean products that contain lead but are compliant with EU RoHS pursuant to a specific EU RoHS exemption.

Green: TI defines "Green" to mean the content of Chlorine (Cl) and Bromine (Br) based flame retardants meet JS709B low halogen requirements of <=1000ppm threshold. Antimony trioxide based flame retardants must also meet the <=1000ppm threshold requirement.

(3) MSL, Peak Temp. - The Moisture Sensitivity Level rating according to the JEDEC industry standard classifications, and peak solder temperature.

(4) There may be additional marking, which relates to the logo, the lot trace code information, or the environmental category on the device.

(5) Multiple Device Markings will be inside parentheses. Only one Device Marking contained in parentheses and separated by a "~" will appear on a device. If a line is indented then it is a continuation of the previous line and the two combined represent the entire Device Marking for that device.

(6) Lead finish/Ball material - Orderable Devices may have multiple material finish options. Finish options are separated by a vertical ruled line. Lead finish/Ball material values may wrap to two lines if the finish value exceeds the maximum column width.

Important Information and Disclaimer:The information provided on this page represents TI's knowledge and belief as of the date that it is provided. TI bases its knowledge and belief on information provided by third parties, and makes no representation or warranty as to the accuracy of such information. Efforts are underway to better integrate information from third parties. TI has taken and continues to take reasonable steps to provide representative and accurate information but may not have conducted destructive testing or chemical analysis on incoming materials and chemicals. TI and TI suppliers consider certain information to be proprietary, and thus CAS numbers and other limited information may not be available for release.

In no event shall TI's liability arising out of such information exceed the total purchase price of the TI part(s) at issue in this document sold by TI to Customer on an annual basis.

TAPE AND REEL INFORMATION

QUADRANT ASSIGNMENTS FOR PIN 1 ORIENTATION IN TAPE

*All dimensions are nominal

Device	Package Type	Package Drawing	Pins	SPQ	Reel Diameter (mm)	Reel Width W1 (mm)	A0 (mm)	B0 (mm)	K0 (mm)	P1 (mm)	W (mm)	Pin1 Quadrant
ESD752DBZR	SOT-23	DBZ	3	3000	180.0	8.4	2.9	3.35	1.35	4.0	8.0	Q3

TAPE AND REEL BOX DIMENSIONS

*All dimensions are nominal

Device	Package Type	Package Drawing	Pins	SPQ	Length (mm)	Width (mm)	Height (mm)
ESD752DBZR	SOT-23	DBZ	3	3000	210.0	185.0	35.0

GENERIC PACKAGE VIEW

DBZ 3

SOT-23 - 1.12 mm max height

SMALL OUTLINE TRANSISTOR



Images above are just a representation of the package family, actual package may vary.
Refer to the product data sheet for package details.

4203227/C

DBZ0003A



PACKAGE OUTLINE

SOT-23 - 1.12 mm max height

SMALL OUTLINE TRANSISTOR

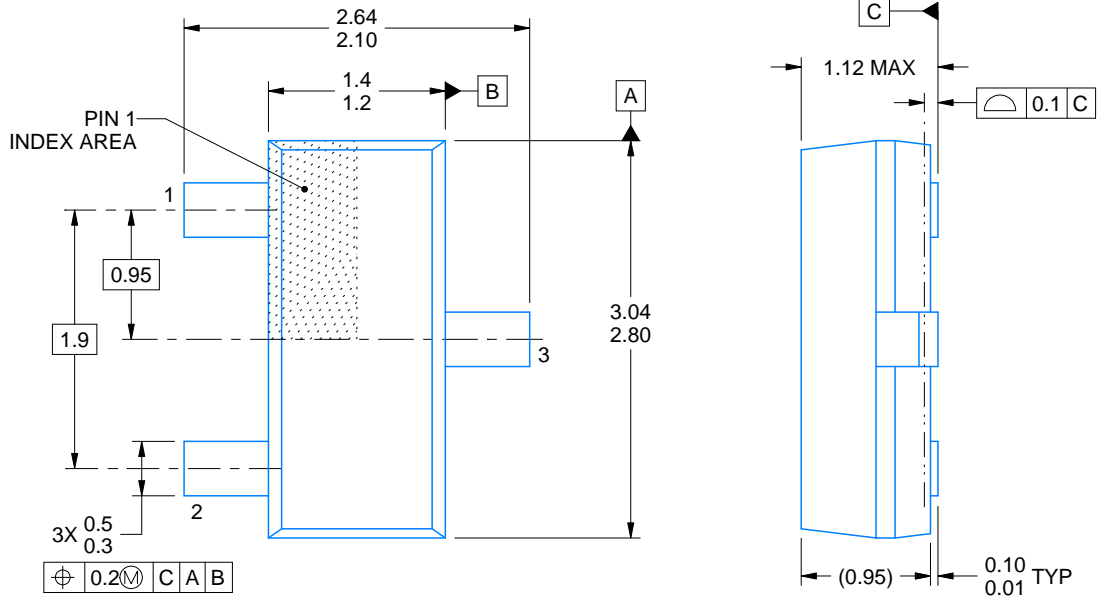

4214838/C 04/2017

NOTES:

1. All linear dimensions are in millimeters. Any dimensions in parenthesis are for reference only. Dimensioning and tolerancing per ASME Y14.5M.
2. This drawing is subject to change without notice.
3. Reference JEDEC registration TO-236, except minimum foot length.

EXAMPLE BOARD LAYOUT

DBZ0003A

SOT-23 - 1.12 mm max height

SMALL OUTLINE TRANSISTOR



LAND PATTERN EXAMPLE
SCALE:15X



SOLDER MASK DETAILS

4214838/C 04/2017

NOTES: (continued)

4. Publication IPC-7351 may have alternate designs.
5. Solder mask tolerances between and around signal pads can vary based on board fabrication site.

EXAMPLE STENCIL DESIGN

DBZ0003A

SOT-23 - 1.12 mm max height

SMALL OUTLINE TRANSISTOR



SOLDER PASTE EXAMPLE
BASED ON 0.125 THICK STENCIL
SCALE:15X

4214838/C 04/2017

NOTES: (continued)

6. Laser cutting apertures with trapezoidal walls and rounded corners may offer better paste release. IPC-7525 may have alternate design recommendations.
7. Board assembly site may have different recommendations for stencil design.

DCK0003A

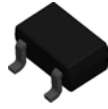

PACKAGE OUTLINE

SOT-SC70 - 1.1 max height

SMALL OUTLINE TRANSISTOR SC70

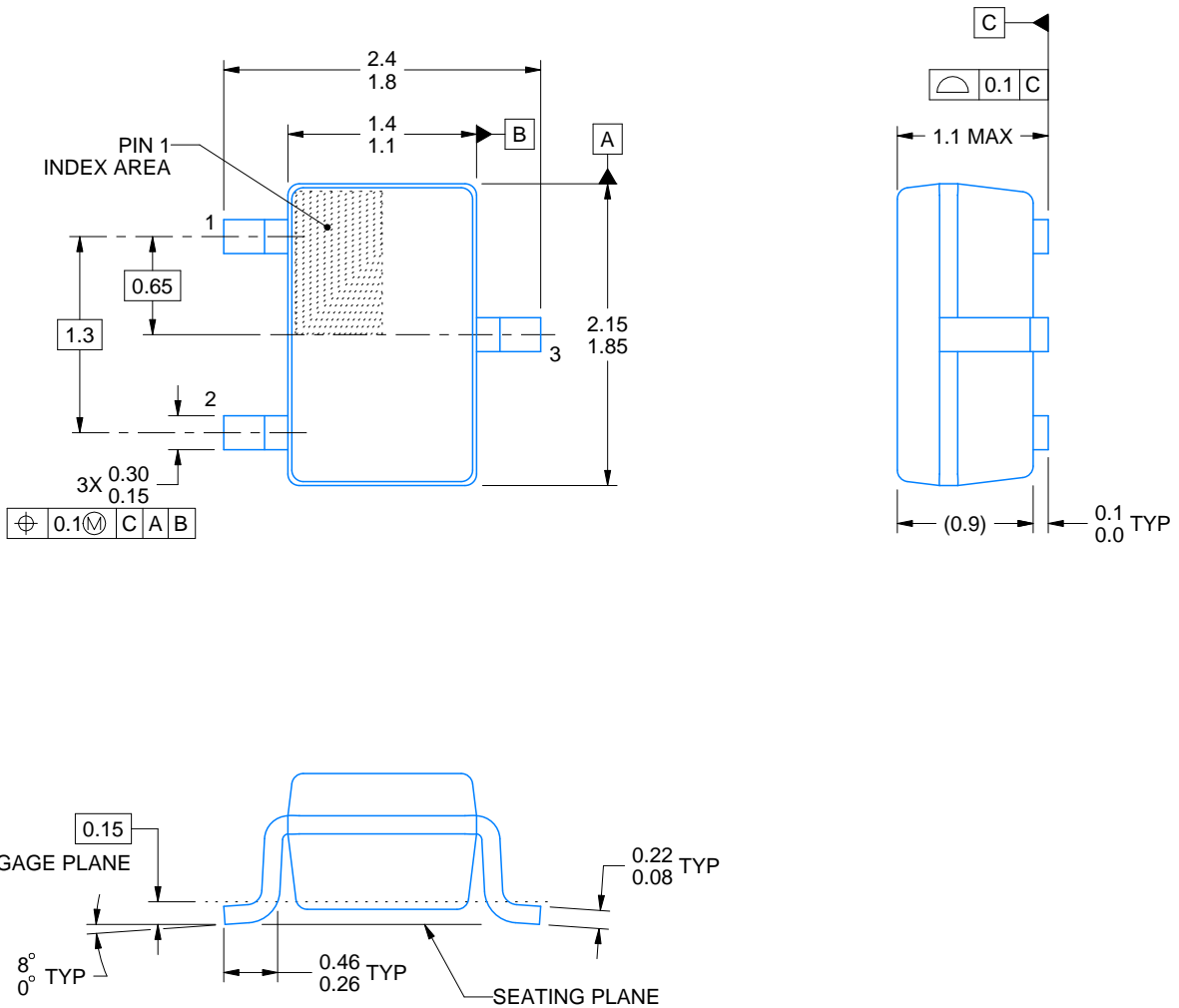

4220745/C 06/2021

NOTES:

1. All linear dimensions are in millimeters. Any dimensions in parenthesis are for reference only. Dimensioning and tolerancing per ASME Y14.5M.
2. This drawing is subject to change without notice.

EXAMPLE BOARD LAYOUT

DCK0003A

SOT-SC70 - 1.1 max height

SMALL OUTLINE TRANSISTOR SC70

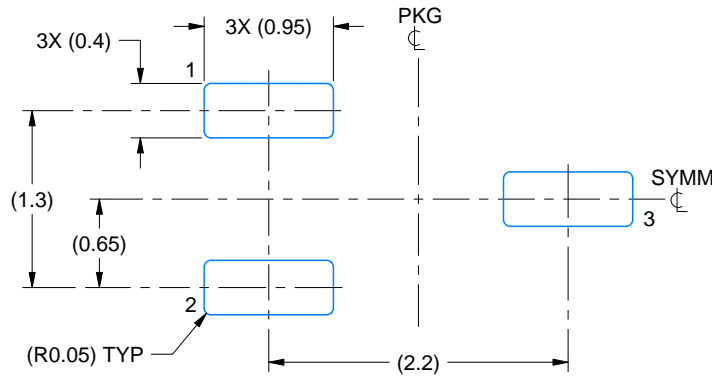

LAND PATTERN EXAMPLE
EXPOSED METAL SHOWN
SCALE:18X

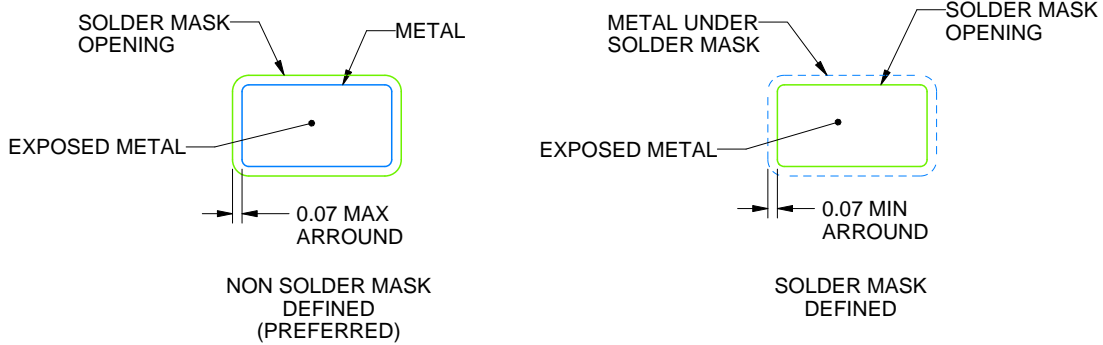

SOLDER MASK DETAILS

4220745/C 06/2021

NOTES: (continued)

- 3. Publication IPC-7351 may have alternate designs.
- 4. Solder mask tolerances between and around signal pads can vary based on board fabrication site.

EXAMPLE STENCIL DESIGN

DCK0003A

SOT-SC70 - 1.1 max height

SMALL OUTLINE TRANSISTOR SC70

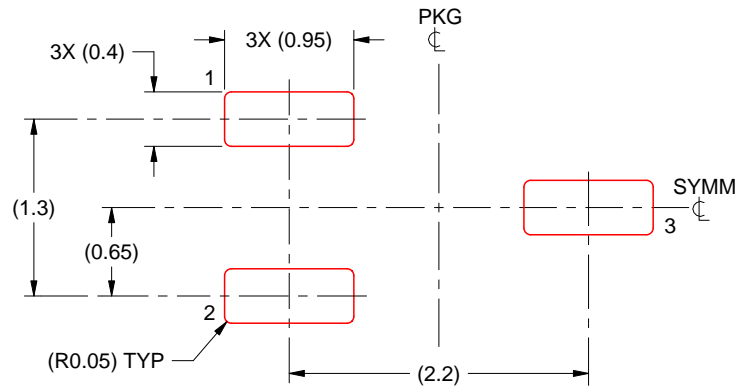

SOLDER PASTE EXAMPLE
BASED ON 0.125 THICK STENCIL
SCALE:18X

4220745/C 06/2021

NOTES: (continued)

5. Laser cutting apertures with trapezoidal walls and rounded corners may offer better paste release. IPC-7525 may have alternate design recommendations.
6. Board assembly site may have different recommendations for stencil design.

IMPORTANT NOTICE AND DISCLAIMER

TI PROVIDES TECHNICAL AND RELIABILITY DATA (INCLUDING DATA SHEETS), DESIGN RESOURCES (INCLUDING REFERENCE DESIGNS), APPLICATION OR OTHER DESIGN ADVICE, WEB TOOLS, SAFETY INFORMATION, AND OTHER RESOURCES "AS IS" AND WITH ALL FAULTS, AND DISCLAIMS ALL WARRANTIES, EXPRESS AND IMPLIED, INCLUDING WITHOUT LIMITATION ANY IMPLIED WARRANTIES OF MERCHANTABILITY, FITNESS FOR A PARTICULAR PURPOSE OR NON-INFRINGEMENT OF THIRD PARTY INTELLECTUAL PROPERTY RIGHTS.

These resources are intended for skilled developers designing with TI products. You are solely responsible for (1) selecting the appropriate TI products for your application, (2) designing, validating and testing your application, and (3) ensuring your application meets applicable standards, and any other safety, security, regulatory or other requirements.

These resources are subject to change without notice. TI grants you permission to use these resources only for development of an application that uses the TI products described in the resource. Other reproduction and display of these resources is prohibited. No license is granted to any other TI intellectual property right or to any third party intellectual property right. TI disclaims responsibility for, and you will fully indemnify TI and its representatives against, any claims, damages, costs, losses, and liabilities arising out of your use of these resources.

TI's products are provided subject to [TI's Terms of Sale](#) or other applicable terms available either on [ti.com](#) or provided in conjunction with such TI products. TI's provision of these resources does not expand or otherwise alter TI's applicable warranties or warranty disclaimers for TI products.

TI objects to and rejects any additional or different terms you may have proposed.

Mailing Address: Texas Instruments, Post Office Box 655303, Dallas, Texas 75265
Copyright © 2022, Texas Instruments Incorporated