

# Bi-directional, low-side phase current sensing with integrated over-current detection

Dennis Hudgins, Current Sensing Products



Sensors are critical in a motor control application. Sensors provide valuable information such as torque, temperature, position and speed. The advancements of today in sensor technologies have enabled improvements in accuracy, performance, cost and reliability. Current technology also allows for integration of multiple features within a sensor that are focused on solving system level challenges. In motor control, several sensors are being used for feedback and protection. One of the key components for motor control feedback and protection is the current sense amplifier.

## Low-Side Phase Current Sensing

In a motor control for DC brushed or brushless drive architectures, low-side current sensing is one of the most cost effective solutions to measure currents due to lower common mode. Low-side sensing is accomplished using an external shunt connected between the controller ground and the system ground as shown in Figure 1. One of the fundamental requirements for using low-side sensing is that the amplifier must be able to support common mode voltages below ground. As the external shunt is connected between the controller ground and system ground, it is critical that the layout of the shunt and current sense amplifier are optimized to maximize current measurement accuracy. Current sense amplifiers from Texas Instruments are specifically designed and factory trimmed to ensure the overall system errors.

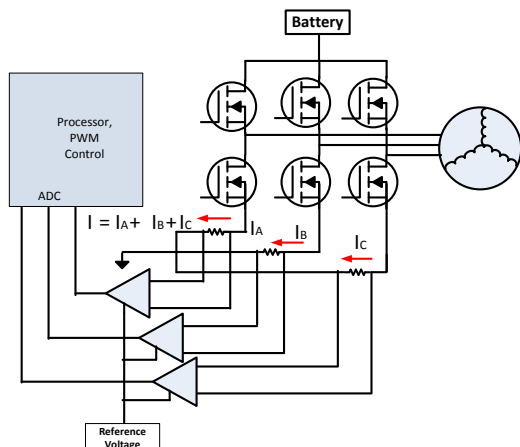

Figure 1. Low-Side Current Sensing

## Bi-Directional Low-Side Phase Current Sensing

In a motor control application, especially for higher power systems, it is critical that the motor is well protected against excessive currents. When excessive currents are passed through the motor due to overheating, the coil within the motor can cause failures leading to a permanent motor damage. Figure 2 illustrates that when the controller switches from phase1 to phase2, the motor acts as an alternator dumping current back into the controller for a brief period of time. For this purpose, it is important that a bi-directional current sense amplifier be implemented to monitor and protect the motor as well as the controller.

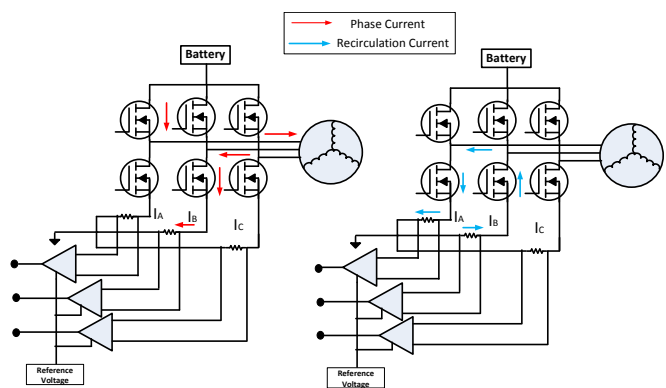
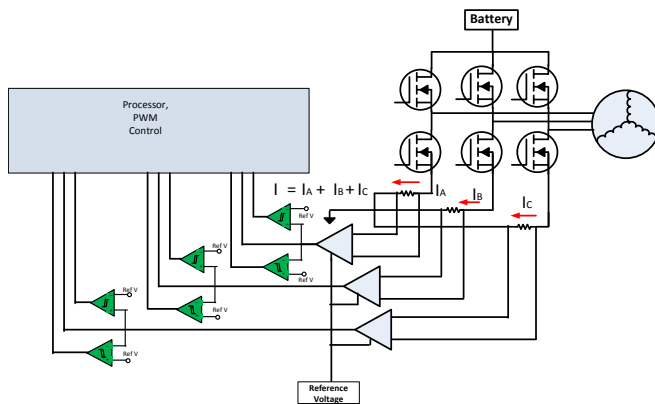

Figure 2. Varying Load Reference

## Over Current Protection

One of the key features that is implemented in motor control circuitry is overcurrent protection (OCP). In the system the output current from low-side is sampled by the ADC in the processor. If the processor detects the sampled output current has exceeded the threshold, the controller can be shutdown. While this is the simplest approach to achieve OCP, the disadvantage with this implementation is the latency added by the ADC conversion. If faster protection is needed, a dual comparator can be connected as shown in Figure 3. The two outputs of the comparator can easily be connected to the GPIO to trigger a shutdown command sequence or action when an alert is identified. One of the drawbacks of using the low-side sensing with dual comparator is the increase in the number of components needed to accomplish OCP.



**Figure 3. Discrete Current Sense Amplifiers And Comparators**

The [INA300](#) includes a high common-mode, bi-directional current-sensing amplifier and two high-speed comparators configured to detect overcurrent conditions. The [INA303](#) comparators are in a window configuration. The device features an adjustable limit threshold range for each comparator set using an external limit-setting resistor. This current-shunt monitor can measure differential voltage signals on common-mode voltages that can vary from 0 V up to 36 V, independent of the supply. The open-drain alert outputs can be configured to operate in either a transparent mode (output status follows the input state) or in a latched mode (alert output is cleared when the latch is reset). The alert response time for comparator one is under 1  $\mu$ s while the alert response for comparator two is set through an external capacitor ranging from 3  $\mu$ s to 10 s.

[Figure 4](#) describes the configuration of [INA303](#) in a low-side motor drive application for phase1. For phase2 and phase3, two additional measurements [INA303](#) are required. The [INA303](#) has a maximum offset voltage of 35  $\mu$ V and a drift of 0.5  $\mu$ V/ $^{\circ}$ C. Low offset, drift and gain error enable accurate measurements across temperatures. With an output slew rate of 4 V/ $\mu$ s, the phase currents can be measured accurately at lower duty cycles with narrow pulses. A 1  $\mu$ s delay on ALERT1 and an adjustable delay on ALERT2 pin from 3  $\mu$ s to 10 s enables optimization for various applications. The analog output of [INA303](#) can be connected to the ADC of the processor. While the two comparator outputs can be connected to GPIOs of the processor. The threshold of the comparator1 can be set by RLIMIT1 resistor. The lower threshold for comparator2 can be set using RLIMIT2 resistor. This configuration can ensure that the motor and the controller can be protected against damage by ensuring the current remains within the safe operating region.

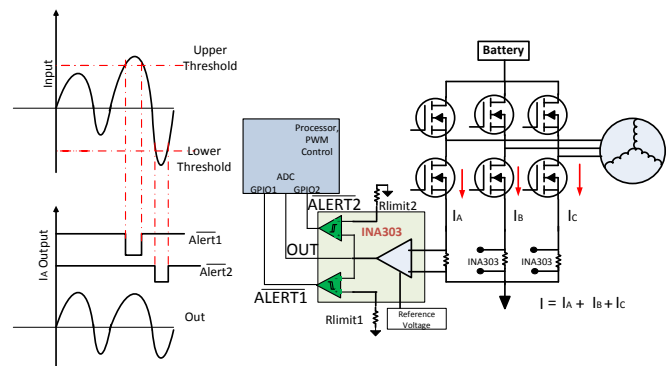

**Figure 4. Low-Side sensing with [INA303](#)**

### Alternate Device Recommendations

The [INA300](#) is another recommended device if the system requires only an over current feature. [INA300](#) is a current sense comparator only. The [INA300](#) has an option to select multiple response times. The fastest available response time is 10  $\mu$ s.

For applications requiring only a single over-current threshold, the [INA301](#) is the recommended device.

Similar to the [INA303](#), the [INA302](#) can be used for applications where two over-current alerts are needed. For example, if independent threshold levels are needed for a warning condition as well as a critical fault condition, the [INA302](#) can be used. For applications that do not require the integrated comparator for on-chip over-current detection, use the [INA181](#) or the [INA185](#) for the smallest solution size.

**Table 1. Alternate Device Recommendations**

Device	Optimized Parameter	Trade-Off
<a href="#">INA300</a>	Package	No analog output, slower response
<a href="#">INA301</a>	Response time, Package	Single alert
<a href="#">INA302</a>	Warning & Critical Alert Capability	Not configured as a window comparator
<a href="#">INA181</a>	Package: SC70-6 & SOT23-6, Lower Cost	Amplifier only
<a href="#">INA185</a>	Package: SOT-563	Amplifier only

**Table 2. Related TI TechNotes**

<a href="#">SBOA162</a>	Measuring Current To Detect Out-of-Range Conditions
<a href="#">SBOA163</a>	High-Side Motor Current Monitoring for Over-Current Protection
<a href="#">SBOA168</a>	Monitoring Current for Multiple Out-of-Range Conditions
<a href="#">SBOA190</a>	Low-Side Current Sense Circuit Integration
<a href="#">SBOA192</a>	External Current Sense Amplifiers vs Integrated On-Board Amplifiers for Current Sensing

## IMPORTANT NOTICE AND DISCLAIMER

TI PROVIDES TECHNICAL AND RELIABILITY DATA (INCLUDING DATASHEETS), DESIGN RESOURCES (INCLUDING REFERENCE DESIGNS), APPLICATION OR OTHER DESIGN ADVICE, WEB TOOLS, SAFETY INFORMATION, AND OTHER RESOURCES "AS IS" AND WITH ALL FAULTS, AND DISCLAIMS ALL WARRANTIES, EXPRESS AND IMPLIED, INCLUDING WITHOUT LIMITATION ANY IMPLIED WARRANTIES OF MERCHANTABILITY, FITNESS FOR A PARTICULAR PURPOSE OR NON-INFRINGEMENT OF THIRD PARTY INTELLECTUAL PROPERTY RIGHTS.

These resources are intended for skilled developers designing with TI products. You are solely responsible for (1) selecting the appropriate TI products for your application, (2) designing, validating and testing your application, and (3) ensuring your application meets applicable standards, and any other safety, security, or other requirements. These resources are subject to change without notice. TI grants you permission to use these resources only for development of an application that uses the TI products described in the resource. Other reproduction and display of these resources is prohibited. No license is granted to any other TI intellectual property right or to any third party intellectual property right. TI disclaims responsibility for, and you will fully indemnify TI and its representatives against, any claims, damages, costs, losses, and liabilities arising out of your use of these resources.

TI's products are provided subject to TI's Terms of Sale ([www.ti.com/legal/termsofsale.html](http://www.ti.com/legal/termsofsale.html)) or other applicable terms available either on [ti.com](http://ti.com) or provided in conjunction with such TI products. TI's provision of these resources does not expand or otherwise alter TI's applicable warranties or warranty disclaimers for TI products.

Mailing Address: Texas Instruments, Post Office Box 655303, Dallas, Texas 75265  
Copyright © 2019, Texas Instruments Incorporated